

Trials@uspto.gov  
571.272.7822

Paper No. 10  
Filed: November 5, 2018

UNITED STATES PATENT AND TRADEMARK OFFICE

---

BEFORE THE PATENT TRIAL AND APPEAL BOARD

---

HUAWEI DEVICE CO., LTD.,

Petitioner,

v.

OPTIS CELLULAR TECHNOLOGY, LLC,

Patent Owner.

---

Case IPR2018-00807  
Patent 8,102,833 B2

---

Before KALYAN K. DESHPANDE, MICHAEL R. ZECHER, and  
JOHN P. PINKERTON, *Administrative Patent Judges*.

PINKERTON, *Administrative Patent Judge*.

DECISION  
Denying Institution of *Inter Partes* Review  
*35 U.S.C. § 314(u)*

APPLE 1004

IPR2018-00807  
Patent 8,102,833 B2

## I. INTRODUCTION

Huawei Device Co., Ltd. (“Petitioner”) filed a Petition requesting an *inter partes* review of claims 1–14 of U.S. Patent No. 8,102,833 B2 (Ex. 1001, “the ’833 patent”). Paper 3 (“Pet.”). Optis Cellular Technology, LLC (“Patent Owner”) filed a Preliminary Response. Paper 7 (“Prelim. Resp.”). Institution of an *inter partes* review is authorized by statute when “the information presented in the petition . . . and any response . . . shows that there is a reasonable likelihood that the petitioner would prevail with respect to at least 1 of the claims challenged in the petition.” 35 U.S.C. § 314(a). For the reasons discussed below, we deny institution of *inter partes* review of claims 1–14 of the ’833 patent.

### A. Related Proceedings

Patent Owner has asserted the ’833 patent against Petitioner in *Optis Wireless Tech., LLC, v. Huawei Techs. Co.*, No. 2:17-cv-00123-JRG-RSP (E.D. Tex.) (the “Litigation”). Pet. 3; Paper 5, 2.

### B. The ’833 Patent

The ’833 patent, entitled “Method for Transmitting Uplink Signals,” issued on January 24, 2012, and claims priority to Korean application 10-2008-0068634, filed on July 15, 2008, and U.S. Provisional Applications, Nos. (1) 60/972,244, filed on September 13, 2007; (2) 60/987,427, filed on November 13, 2007; and (3) 60/988,433, filed on November 16, 2007. Ex. 1001, [30], [60], 1:7–15.

The ’833 patent relates generally to user equipment (UE) of a mobile communication system transmitting uplink signals, including ACK/NACK signals, control signals other than ACK/NACK signals, and data signals.

IPR2018-00807  
Patent 8,102,833 B2

Ex. 1001, [57], 1:21–24. The patent describes that control signals transmitted to the uplink “include uplink ACK/NACK<sup>1</sup> signals for HARQ communication, channel quality indicator (CQI), and precoding matrix index (PMI).” *Id.* at 1:29–32. The ’833 patent specifically distinguishes ACK/NACK signals from control signals other than ACK/NACK signals and states “‘control signals’ will mean those other than the ACK/NACK signals.” *Id.* at 5:15–16; *see also id.* at 1:43–45 (stating “the control signals will mean those except for ACK/NACK signals”).

The ’833 patent explains that the 3GPP LTE system uses a single carrier frequency division multiplexing access (SC-FDMA) scheme for uplink signal transmission. *Id.* at 1:33–35. According to the ’833 patent, the 3GPP LTE system prescribes that data signals and control signals among the uplink signals are first multiplexed and ACK/NACK signals are transmitted to the multiplexed signals by puncturing the data or control signals when uplink ACK/NACK signal transmission is required for downlink data. *Id.* at 1:35–40. As the ’833 patent also describes, it was determined that, in 3GPP LTE systems, when the control information is multiplexed with the data information, “the control information is transmitted near a reference signal.” *Id.* at 1:45–49. The ’833 patent explains that “control signals generally

---

<sup>1</sup> Petitioner’s expert, Dr. Jonathan Wells, opines that an example of an uplink control signal would be an acknowledgement sent by the UE to the base station to confirm it has received a transmitted data signal. Ex. 1008 ¶ 38. According to Dr. Wells, a positive acknowledgement that the data signal was properly received by the UE is known as an ACK, and a negative acknowledgement if there was some problem receiving the data signal is known as a NACK. *Id.*

IPR2018-00807  
Patent 8,102,833 B2

require higher reliability than the data signals,” and “the ACK/NACK signals require higher reliability than other types of control signals.” *Id.* at 1:51–57. Accordingly, the ’833 patent describes that, when uplink ACK/NACK signal transmission is required while all the control signals are transmitted by approximating to the reference signal, “problems occur in that the ACK/NACK signals can neither be transmitted by puncturing the control signals arranged near the reference signal nor be transmitted near the reference signal.” *Id.* at 1:54–62. Thus, the ’833 patent describes a method for transmitting uplink signals by efficiently arranging ACK/NACK signals and other control signals in a resource region considering priority among them. *Id.* at 2:7–10; *see also id.* at 2:25–27 (stating that “arranging the ACK/NACK signals at both symbols near to symbols through which a reference signal is transmitted”).

The ’833 patent describes transmitting information in accordance with the SC-FDMA scheme in which information sequences are transmitted using one “resource block” and one “sub-frame.” *Id.* at 5:31–40. Each sub-frame includes two slots, and each slot includes 7 SC-FDMA symbols. *Id.* at 5:40–45, cl. 3. Two of the 14 SC-FDMA symbols in each sub-frame are used as reference signals that are pilot signals. *Id.* at 5:40–43. Each resource block includes 12 OFDM (orthogonal frequency division multiple access) subcarriers and 7 SC-FDMA symbols in one slot. *Id.* at 5:37–40. The ’833 patent explains that, at this time, the number of modulation symbols of the information that can be transmitted to the uplink becomes  $12 \times 12 = 144$ . *Id.* at 5:43–45. The ’833 patent further explains that 144 information sequences can be transmitted through 12 virtual subcarriers and 12 SC-FDMA



IPR2018-00807  
 Patent 8,102,833 B2

symbols, which “can be represented by a matrix structure of 12\*12 called a time-frequency mapper.” *Id.* at 5:46–49.

An annotated version of Figure 6 of the '833 patent is reproduced below.

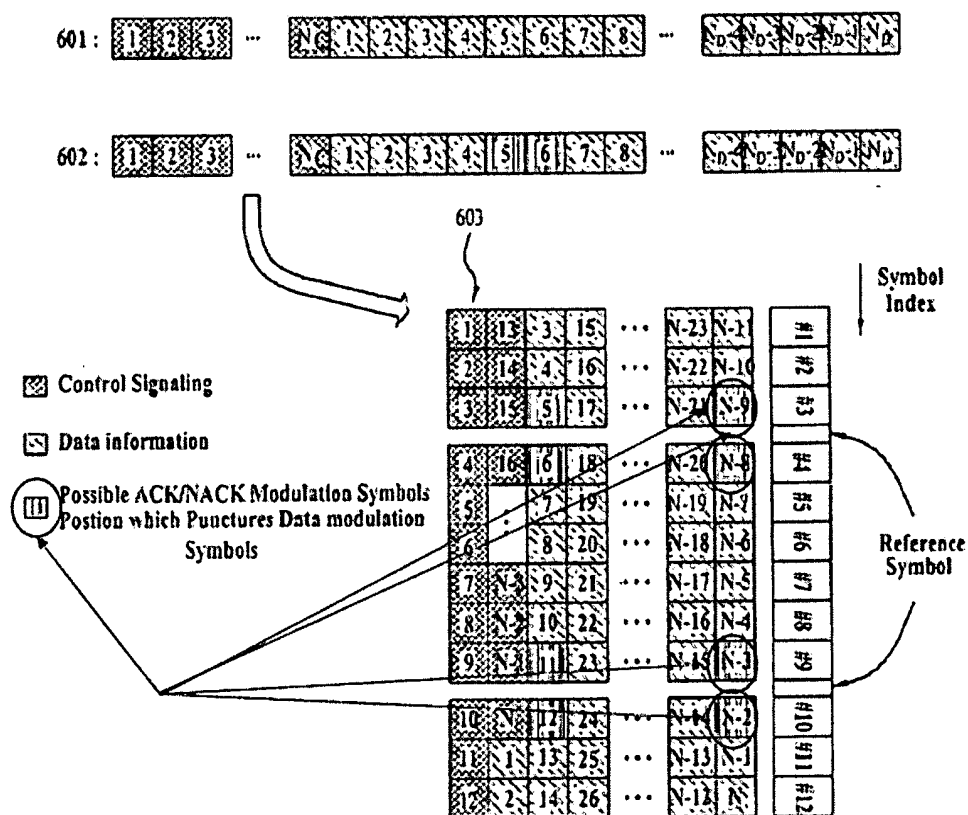

The annotated version of Figure 6 above is a diagram illustrating a method for transmitting uplink signals in accordance with one embodiment of the '833 patent. *Id.* at 3:33–35, 6:49–51. This figure includes three portions, arranged vertically, and is slightly annotated by Patent Owner with red lines and circles showing the location of possible ACK/NACK symbols. The top portion of Figure 6 (labeled 601) is a horizontal strip of small,

IPR2018-00807  
Patent 8,102,833 B2

square blocks representing control signals (each numbered 1 through  $N_C$ ) and data signals (each numbered 1 through  $N_D$ ). This top portion of the figure illustrates that control and data signals are multiplexed serially, if ACK/NACK signals are not transmitted, with control signals placed at the front (i.e., starting at the left) and data signals placed at the rear of the multiplexed signals. *Id.* at 6:60–63. The second or middle portion of Figure 6 (labeled 602) is also a horizontal strip of small, square blocks, again representing data signals and control signals multiplexed serially, with data signals placed at the front, and with ACK/NACK signals to be transmitted that “are arranged by puncturing the multiplexed data.”<sup>2</sup> *Id.* at 6:63–66. In this portion of Figure 6, the ACK/NACK symbols are inserted in place of data signals 5, 6,  $N_D-3$ , and  $N_D-2$ .

The third portion of Figure 6 (labeled 603), which is located at the bottom, illustrates the embodiment in which information sequences such as those shown in the second portion of Figure 6 (labeled 602) are mapped with SC-FDMA symbols according to the time-first mapping method, and then transmitted on the uplink. *Id.* at 6:52–56; 6:66–7:2. This portion of Figure 6 is a two-dimensional “time-frequency region” that independent claim 1 refers to as “a 2-dimensional resource matrix.” *Id.* at 6:66–7:2, 9:6–7. In accordance with the time-first mapping method, the multiplexed signals (such as 602) are mapped row by row to the resource matrix in which rows

---

<sup>2</sup> As used in the '833 patent, “puncturing” means “overwriting” or “replacing” specific information. *Id.* at 6:15–21 (“overwritten” means that specific information is skipped and the corresponding region is mapped; “overwritten” also means that the length of the entire information is maintained equally even after specific information is inserted).

IPR2018-00807  
Patent 8,102,833 B2

correspond to subcarriers and columns correspond to SC-FDMA symbols. *Id.* at 6:66–7:3; 7:6–10; 9:6–21. Resource matrix 603 shows a total of 14 SC-FDMA symbols along the time axis (the vertical axis) within one subframe—12 SC-FDMA symbols (numbered from top to bottom as #1 through #12 in a column to the right of the matrix) and two SC-FDMA symbols that carry reference signals in a part between symbol indices #3 and #4 and in a part between symbol indices #9 and #10. *Id.* at 5:37–45; 7:2–5. The '833 patent explains that the ACK/NACK signals are set in such a manner that they overwrite the data signals on both sides of the parts to which the reference signals are transmitted (i.e., into SC-FCMA symbols #3, 4, 9, and 10 in Figure 6). *Id.* at 7:10–14. These overwritten ACK/NACK signals are labeled N-2, N-3, N-8, and N-9 (and are circled in red) in matrix 603, the third portion of Figure 6.

*C. Challenged Claims*

Petitioner challenges claims 1–14 of the '833 patent. Independent claim 1, which is illustrative of the challenged claims, is reproduced below (with paragraph lettering added as in the Petition):

1. A method for transmitting uplink signals comprising control signals and data signals in a wireless communication system, the method comprising:

[1a] serially multiplexing first control signals and data signals in a mobile station, wherein the first control signals are placed at a front part of the multiplexed signals and the data signals are placed at a rear part of the multiplexed signals;

[1b] mapping the multiplexed signals to a 2-dimensional resource matrix comprising a plurality of columns and a plurality of rows, wherein the columns and the rows of the 2-dimensional

IPR2018-00807  
Patent 8,102,833 B2

resource matrix correspond to single carrier frequency divisional multiple access (SC-FDMA) symbols and subcarriers for each SC-FDMA symbol, respectively, wherein a number of columns of the 2-dimensional resource matrix corresponds to a number of SC-FDMA symbols within one subframe except specific SC-FDMA symbols used for a reference signal, and wherein the multiplexed signals are mapped from the first column of the first row to the last column of the first row, the first column of the second row to the last column of the second row, and so on, until all the multiplexed signals are mapped to the 2-dimensional resource matrix;

[1c] mapping ACK/NACK control signals to specific columns of the 2-dimensional resource matrix, wherein the specific columns correspond to SC-FDMA symbols right adjacent to the specific SC-FDMA symbols, wherein the ACK/NACK control signals overwrite some of the multiplexed signals mapped to the 2-dimensional resource matrix at step (b) from the last row of the specific columns; and

[1d] transmitting the signals mapped to the 2-dimensional resource matrix at steps (b) and (c) by column by column to a base station.

Ex. 1001 at 38:10–60.

*D. Evidence of Record*

Petitioner relies upon the following references, as well as the Declaration of Dr. Jonathan Wells (Ex. 1008):

IPR2018-00807  
 Patent 8,102,833 B2

<b>Exhibit</b>	<b>Reference</b>	<b>Publication or Filing Date</b>
Ex. 1006	U.S. Patent No. 8,331,328 B2 (Papasakellariou)	Filed June 4, 2008 <sup>3</sup>
Ex. 1010	U.S. Patent Publication No. 2006/0262871 (Cho)	Published Nov. 23, 2006
Ex. 1011	Motorola, 3GPP TSG RAN #50, R1-073361, "Uplink channel interleaving" (Motorola)	Published Aug. 31, 2007

*E. Asserted Ground of Unpatentability*

Petitioner challenges the patentability of claims 1–14 of the '833 patent based on the following ground:

<b>Reference(s)</b>	<b>Basis</b>	<b>Claims Challenged</b>
Combination of Papasakellariou, Cho, and Motorola	§ 103(a)	1–14

## II. DISCUSSION

*A. Claim Construction*

*1. Applicable Law*

In an *inter partes* review, claim terms in an unexpired patent are interpreted according to their broadest reasonable construction in light of the

---

<sup>3</sup> Papasakellariou claims the benefit of U.S. Provisional Application No. 60/942,843, filed on June 8, 2007. Ex. 1006, [60].

IPR2018-00807  
Patent 8,102,833 B2

specification of the patent in which they appear. 37 C.F.R. § 42.100(b). Under that standard, and absent any special definitions, we give claim terms their ordinary and customary meaning, as they would be understood by one of ordinary skill in the art, in the context of the entire patent disclosure. *In re Translogic Tech., Inc.*, 504 F.3d 1249, 1257 (Fed. Cir. 2007).

Only those terms in controversy need to be construed, and then only to the extent necessary to resolve the controversy. *Nidec Motor Corp. v. Zhongshan Broad Ocean Motor Co.*, 868 F.3d 1013, 1017 (Fed. Cir. 2017) (citing *Vivid Techs., Inc. v. Am. Sci. & Eng'g, Inc.*, 200 F.3d 795, 803 (Fed. Cir. 1999)).

## 2. *Petitioner's Position*

Petitioner asserts that, in the Litigation, the parties agreed upon several constructions that were adopted by the district court. Pet. 13 (citing Ex. 1013, 12–14). Petitioner also asserts that it adopts the court's constructions for purposes of this proceeding. *Id.*

## 3. *Patent Owner's Position*

Patent Owner asserts that for purposes of its Preliminary Response, it “agrees to all of the proposed constructions.” Prelim. Resp. 48. Patent Owner also contends that we should find that the steps of claims 1 and 8 of the '833 patent must be performed in the order recited in the claims. *Id.* at 48–50 (citing *Altiris, Inc. v. Symantec Corp.*, 318 F.3d 1363, 1369–70 (Fed. Cir. 2003)). In this regard, Patent Owner argues that the express language of the claims requires the steps of each of claims 1 and 8 to be performed in order. *Id.* Patent Owner also asserts that in the Litigation, the parties agreed

IPR2018-00807  
Patent 8,102,833 B2

on constructions that impose an order to the steps of both claim 1 and 8. *Id.* at 50 (citing Ex. 1013 at 13).

4. *Analysis*

We adopt the district court's claim constructions in the Litigation for the terms and phrases of the '833 patent, for the purposes of this Decision, because they are consistent with the specification of the '833 patent. *See* Ex. 1010, 12–14. We determine there is no reason to further construe any other terms or phrases, or determine the order of steps of independent claims 1 and 8, beyond the determinations of the district court.

*B. Asserted Obviousness of Claims 1–14 Over the Combination of Papasakellariou, Cho, and Motorola*

Petitioner contends the combination of Papasakellariou (Ex. 1006), Cho (Ex. 1010), and Motorola (Ex. 1011) renders claims 1–14 of the '833 patent obvious. Pet. 28–90. Petitioner asserts that Papasakellariou, which was filed on June 4, 2008, and claims priority to U.S. Provisional Application No. 60/942,843, filed on June 8, 2007 (Ex. 1007, “the '843 provisional”), is prior art under 35 U.S.C. § 102(e) as of the filing date of the provisional. *Id.* at 16–27. Patent Owner contends that Papasakellariou does not qualify as prior art to the '833 patent under § 102(e) because the '833 patent claims are entitled to priority to an earlier-filed provisional application, which predates the June 4, 2008 filing date of Papasakellariou, and Petitioner has failed to meet its burden of showing that the '843 provisional provides support for the disclosures on which Petitioner relies in Papasakellariou. Prelim. Resp. 50–64. Thus, the fundamental issue raised by the parties is whether Papasakellariou is prior art to the '833 patent under § 102(e) based on the priority date of the '843 provisional.

IPR2018-00807  
Patent 8,102,833 B2

For the reasons set forth below, we agree with Patent Owner that Papasakellariou is not prior art to the '833 patent because Petitioner has failed to show Papasakellariou is entitled to claim the benefit of the filing date of the '843 provisional. Thus, we determine that Petitioner has failed to show a reasonable likelihood of prevailing on its assertion that claims 1–14 of the '833 patent are obvious based on the combination of Papasakellariou, Cho, and Motorola.

*1. Effective Date of '833 Patent*

The '833 patent issued from an application filed on September 11, 2008. Ex. 1001, [22]. Papasakellariou issued from an application filed on June 4, 2008. Ex. 1006, [22]. Because the application that led to the issuance of Papasakellariou was filed before the application for the '833 patent, Petitioner met its initial burden of production in establishing Papasakellariou as prior art. *See In re Magnum Oil Tools Int'l, Ltd.*, 829 F.3d 1364, 1376 (Fed. Cir. 2016); *Dynamic Drinkware, LLC v. Nat'l Graphics, Inc.*, 800 F.3d 1375, 1379 (Fed. Cir. 2015) (discussing *Tech. Licensing Corp. v. Videotek, Inc.*, 545 F.3d 1316, 1327 (Fed. Cir. 2008)). Thus, the burden of production shifts to Patent Owner to argue or produce evidence that the challenged claims of the '833 patent are entitled to claim priority to one or more of the '833 patent's provisional applications. Pet. 20 n.5 (citing *Magnum Oil*, 829 F.3d at 1376; *Dynamic Drinkware*, 800 F.3d at 1379–80). In that regard, Petitioner asserts it “does not concede” that the '833 patent is entitled to claim the benefit of the provisional applications and Korean application identified on the face of the '833 patent. *Id.* at 7 n.2.



IPR2018-00807  
Patent 8,102,833 B2

As Patent Owner argues, the '833 patent claims priority to provisional application no. 60/972,244, filed on September 13, 2007 (Ex. 1003), provisional application no. 60/987,427, filed on November 13, 2007 ("the '427 provisional," Ex. 1004), and provisional application no. 60/988,433, filed on November 16, 2007 (Ex. 1012). Prelim. Resp. 18–19 (citing Ex. 1001, 1:11–15). Patent Owner contends that the priority date of the '833 patent is November 13, 2007, the filing date of the '427 provisional. *Id.* In support of this contention, Patent Owner first asserts that, in the Litigation, "Petitioner has stipulated to the November 13, 2007 priority date of the '833 patent." *Id.* at 19 (citing Ex. 2009, 13 ("The priority date of the asserted claims of the '833 patent is November 13, 2007.")). Patent Owner notes that Exhibit 2009 is the Joint Final Pretrial Order in the Litigation and that, as of the date thereof, only claims 8 and 13 of the '833 patent were being asserted. *Id.* n.3. Patent Owner asserts that claim 8 is the apparatus claim version of method claim 1, which includes nearly identical claim limitations and is entitled to the same priority date. *Id.* Second, Patent Owner asserts that, "in an abundance of caution, Patent Owner presents a claim chart identifying disclosures from the '427 provisional that support claim 1 of the '833 patent." *Id.* at 19–28 (citing Ex. 1004, 7–43, 53–79).

Based on Patent Owner's evidence, we agree with Patent Owner that the challenged claims of the '833 patent are entitled to the benefit of the filing date of the '427 provisional on November 13, 2007. In that regard, Patent Owner's evidence demonstrates that Petitioner stipulated that the earliest effective priority date of claims 8 and 13 of the '833 patent is November 13, 2007. Comparing claim 8 with claim 1, we agree with Patent

IPR2018-00807  
Patent 8,102,833 B2

Owner that claim 8 is the apparatus claim version of method claim 1, which includes nearly identical claim limitations to claim 8, and is entitled to the same priority date as claim 8. Prelim Resp. 19. Patent Owner has also persuasively demonstrated in its claim chart that the limitations of claims 1–14 are supported by the disclosure of the '427 provisional. *Id.* at 19–28. Therefore, we determine that claims 1–14 of the '833 patent are entitled to the benefit of the filing date of the '427 provisional on November 13, 2007.

2. *Effective Date of Papasakellariou*

In *Dynamic Drinkware*, the Federal Circuit held that, in an *inter partes* review, once a patent owner has responded to a petitioner's argument with sufficient evidence that its patent is entitled to a priority date before a prior art reference, the burden of production shifts back to the petitioner to prove that the prior art reference is entitled to the benefit of the filing date of a provisional application. 800 F.3d at 1380. Thus, because Patent Owner has demonstrated that the earliest effective priority date of the '833 patent is November 13, 2007, which is before the filing of Papasakellariou on June 4, 2008, the burden of production returns to Petitioner to prove that Papasakellariou is entitled to the benefit of the earlier June 8, 2007, filing date of the '843 provisional.

As the parties argue and acknowledge, to meet its burden of proof, Petitioner is required to make two showings: (1) at least one claim of Papasakellariou is supported by the '843 provisional; and (2) the portions of Papasakellariou relied upon in the Petition to demonstrate that the claims of the '833 patent would have been obvious were included in the '843 provisional. Prelim. Resp. 33 (citing *Dynamic Drinkware*; 800 F.3d at

IPR2018-00807  
Patent 8,102,833 B2

1378–79, 1383; *In re Giacomini*, 612 F.3d 1380, 1383 (Fed. Cir. 2010); *Ex parte Mann*, No. 2015-3571, 2016 WL 7487271 (PTAB Dec. 21, 2016)); Pet. 19 (citing *Cisco Sys., Inc. v. Capella Photonics, Inc.*, IPR2014-01276, slip op. at 21–22 (PTAB Feb. 17, 2016) (Paper 40) (“Interpreting *Dynamic Drinkware*, 800 F.3d at 1378, the Board has held that a § 102(e) reference is available as prior art as of its provisional application’s filing date when the provisional provides support for (1) at least one claim of the § 102(e) reference and (2) the subject matter on which the petitioner relies.”)).

Petitioner contends that the relevant disclosures of Papasakellariou are available as prior art and entitled to a § 102(e) prior art date of June 8, 2007, because the ’843 provisional provides support for (1) claims 4 and 5 of Papasakellariou and (2) the subject matter on which the Petition relies. Pet. 19–20. In regard to aforementioned item (1), Petitioner cites the portions of the ’843 provisional it contends support the limitations of claims 4 and 5 of Papasakellariou. *Id.* at 21–27. In regard to aforementioned item (2), Petitioner asserts that, as shown in its obviousness analysis in the Petition, “the subject matter on which this Petition relies is disclosed in the *Papasakellariou Provisional* [i.e., the ’843 provisional], as well as *Papasakellariou*.” *Id.* at 27.

Patent Owner argues that, even assuming that Petitioner can establish that the ’843 provisional supports one or more claims of Papasakellariou, Petitioner cannot make the required showing under *Dynamic Drinkware* because “the subject matter from *Papasakellariou* upon which Petitioner relies is not in the *Papasakellariou Provisional* [i.e., the ’843 provisional].” Prelim. Resp. 52. In particular, Patent Owner argues that Petitioner relies on

IPR2018-00807  
Patent 8,102,833 B2

Figure 2, and its related disclosures, from Papasakellariou, which purports to disclose a two-step process wherein data and control signals are multiplexed before being punctured with ACK/NACK signals, but this two-step embodiment is not disclosed by the '843 provisional. *Id.* at 52–64.

We agree with Patent Owner that Petitioner has not met its burden of proof because Petitioner has not shown that the '843 provisional discloses Figure 2 and the related disclosures in Papasakellariou, on which the Petition's obviousness analysis relies, or any corresponding embodiment or teachings.

As Patent Owner argues, Petitioner and its expert, Dr. Wells, rely heavily on Figure 2 of Papasakellariou. Prelim. Resp. 52 (citing Pet. 33, 70, 79, 81, 84; Ex. 1008 ¶¶ 44–45, 103–104, 155, 221, 222, 239, 240, 242, 244, 246). For example, in regard to the portion of limitation 1[a] reciting “multiplexing first control signals and data signals in a mobile station,” Petitioner argues that Figure 2 of Papasakellariou “is a block diagram illustrative of an exemplary SC-FDMA transmitter” and “discloses multiplexing CQI bits 205 (i.e., ‘first control signals’) and data bits 210 (220) (i.e., ‘data signals’) in a mobile station.” Pet. 32–33 (citing Ex. 1006, 2:5–18, 3:55–56). Petitioner also argues that a person of ordinary skill in the art would have understood that “‘first control signals’ refers to control signals . . . other than ACK/NACK control signals.” *Id.* (citing Ex. 1001, [57], 1:40–44, 5:13–24; Ex. 1008 ¶¶ 153, 154). In regard to the portion of limitation 1[c] reciting “wherein the ACK/NACK control signals overwrite some of the multiplexed signals mapped to the 2-dimensional resource matrix,” Petitioner argues that Papasakellariou discloses that “[c]oded CQI

IPR2018-00807  
 Patent 8,102,833 B2

bits 205 and coded data bits 210 are multiplexed 220” and that “if ACK/NACK bits also need to be multiplexed,”<sup>4</sup> data bits or CQI bits (if any) “may be punctured.” *Id.* at 63 (quoting Ex. 1006, 2:6–13). As indicated in Petitioner’s supporting citation, this disclosure of Papasakellariou also concerns Figure 2 of Papasakellariou. *See* Ex. 1006, 2:5–13. Thus, as Patent Owner argues, and we agree, Petitioner relies on Figure 2 of Papasakellariou, and its related disclosure, to illustrate a two-step process of multiplexing data and control information other than ACK/NACK followed by puncturing with ACK/NACK signals. Prelim. Resp. 52.

Figure 2 of Papasakellariou is reproduced below.

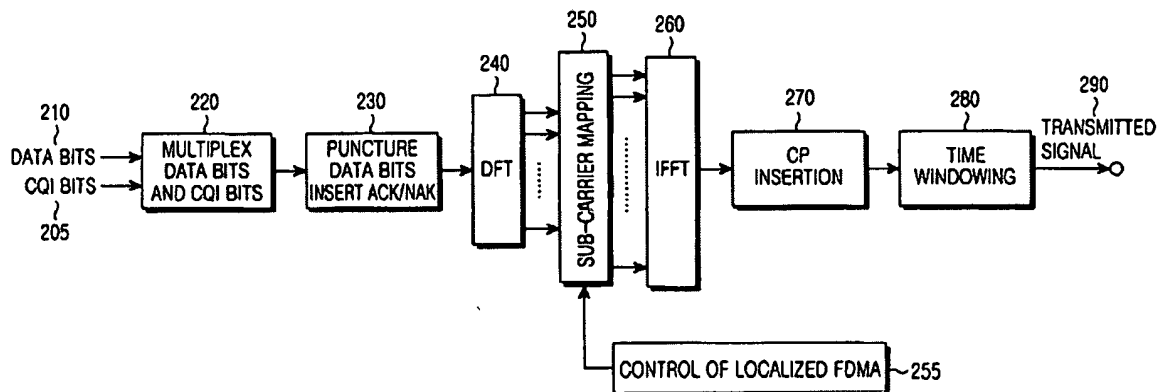

FIG.2

<sup>4</sup> Although Papasakellariou refers to “ACK/NAK,” rather than “ACK/NACK” as used in the ’833 patent, there is no dispute that these acronyms have the same meaning. Thus, for clarity and consistency, we replace the references to “ACK/NAK” in those portions of Papasakellariou quoted or referred to in this Decision with “ACK/NACK.”

IPR2018-00807  
Patent 8,102,833 B2

As described in Papasakellariou, Figure 2 “is a block diagram illustrative of a first exemplary SC-FDMA transmitter for multiplexing data bits, CQI bits, and ACK/NACK bits in a transmission sub-frame.” Ex. 1006, 3:58–60. There are 7 blocks in Figure 2, extending horizontally from left to right, numbered 220, 230, 240, 250, 260, 270, and 280, with 1 block labeled “CONTROL OF LOCALIZED FDMA 255” located under the others (and showing its output being input into the block labeled “SUB-CARRIER MAPPING 250”). As shown in Figure 2, coded CQI bits 205 and coded data bits 210 are multiplexed at block 220. *Id.* at 2:6–7. Papasakellariou explains that, if ACK/NACK bits also need to be multiplexed, “the exemplary embodiment assumes that data bits are punctured to accommodate ACK/NACK bits [at block] 230.” *Id.* at 2:7–10. Papasakellariou further explains that the discrete Fourier transform (DFT) of the combined data bits and control bits is then obtained at block 240, sub-carriers 250 corresponding to the assigned transmission bandwidth are selected, the inverse fast Fourier transform (IFFT) is performed at block 260, and finally the cyclic prefix (CP) and filtering are applied at blocks 270 and 280, respectively, to the transmitted signal 290. *Id.* at 2:13–18.

Patent Owner also argues, and we agree, that Petitioner has not shown that the '843 provisional discloses an embodiment comprising a multi-step process in which data and control signals are multiplexed before being punctured with ACK/NACK signals, as disclosed in the '833 patent and, as Petitioner argues, in Figure 2 of Papasakellariou. Prelim. Resp. 53. First, we agree with Patent Owner's argument that neither Figure 2 nor its description in Papasakellariou appears in the '843 provisional. *Id.* at 56.

IPR2018-00807  
 Patent 8,102,833 B2

Second, we also agree with Patent Owner's arguments that Petitioner has failed to show that Figure 2 of the '843 provisional discloses the subject matter of Figure 2 of Papasakellariou on which Petitioner relies in its obviousness analysis in the Petition. Petitioner cites Figure 2 of the '843 provisional as disclosing "multiplexing first control signals and data signals in a mobile station" (Pet. 34) and as "illustrating a transmitter with substantially the same structure as Figure 2 of *Papasakellariou*" (*id.* 71–72). As Patent Owner argues, however, Figure 2 of the '843 provisional does not correspond to Figure 2 of Papasakellariou, but instead corresponds to the embodiment of Figure 3 of Papasakellariou, which is described as an alternative embodiment to Figure 2 of Papasakellariou. Prelim. Resp. 56–57 (citing Ex 1006, 2:19–31). In other words, as Patent Owner argues, Papasakellariou discloses two distinct embodiments for the SC-FDMA transmitter—namely, a first embodiment shown in Figure 2 and the second alternative embodiment shown in Figure 3. *Id.* at 54–56.

Figure 2 of the '843 provisional and Figure 3 of Papasakellariou are reproduced below.

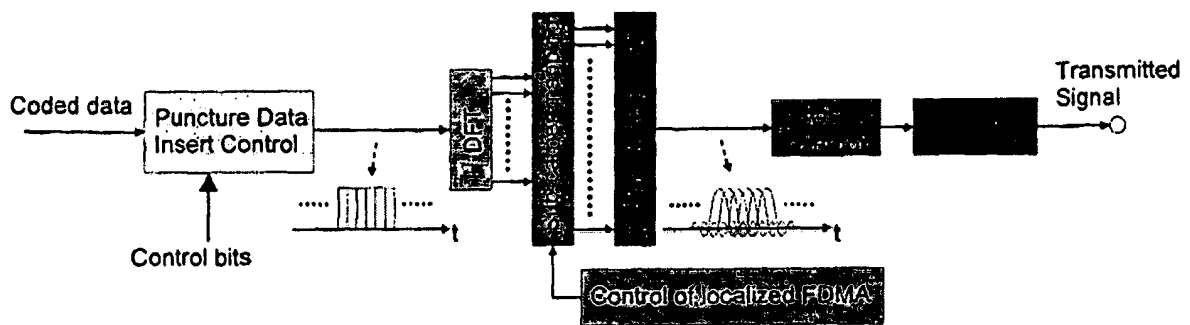

**Figure 2: Multiplexing of Control and Data Signals**

IPR2018-00807  
 Patent 8,102,833 B2

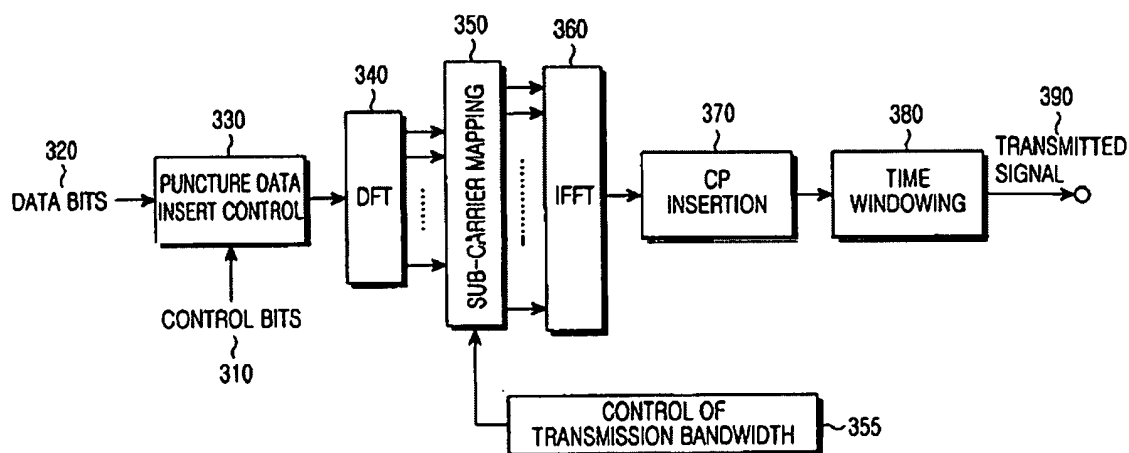

FIG. 3

Both of these figures are block diagrams of an SC-FDMA transmitter. Ex. 1006, 3:58–60; Ex. 1007, 2. Figure 2 of the '843 provisional is labeled “Multiplexing of Control and Data Signals,” and depicts 6 blocks extending horizontally from left to right, with 1 block labeled “Control of localized FDMA” located under the others (and showing its output being input into the block labeled “Sub-carrier mapping”). Figure 3 of Papasakellariou, which is not labeled, is described in Papasakellariou as “another block diagram illustrative of a second exemplary SC-FDMA transmitter.” Ex. 1006, 3:58–59. Figure 3 also depicts 6 blocks extending horizontally from left to right, with 1 block labeled “Control of Transmission Bandwidth 355” located under the others (and showing its output being input into the block labeled “SUB-CARRIER MAPPING 350”). Apart from the darkened labels of four of the blocks of Figure 2 of the '843 provisional, the diagrams of Figure 2 of the '843 provisional and Figure 3 of Papasakellariou are



IPR2018-00807  
Patent 8,102,833 B2

essentially the same. In particular, both show control bits and data bits input into the first block on the left labeled “Puncture Data Insert Control,” and subsequent blocks labeled DFT, Sub-Carrier Mapping, IFFT, CP Insertion, and Time Windowing, and then the transmitted signal.

Patent Owner argues, and we agree, that Petitioner does not cite Figure 3 of Papasakellariou or its related disclosure “a *single time*” in the Petition. Prelim. Resp. 57. We also agree with Patent Owner that the description of Figure 3 in Papasakellariou is almost exactly the same as the description of Figure 2 in the ’843 provisional. Prelim. Resp. 57 (*compare* Ex. 1006, 2:19–31, *with* Ex. 1007, 2).

Third, we agree with Patent Owner that Figure 2 of the ’843 provisional does not disclose a multi-step process in which data signals and control signals are multiplexed before being punctured by ACK/NACK signals, as disclosed in the ’833 patent and, as Petitioner argues, in Figure 2 of Papasakellariou. Prelim. Resp. 52–53. Patent Owner argues, and we agree, that the ’833 patent “distinguishes between multiplexing (as in the case of data and control information) and puncturing (as in the case of ACK/NACK, which involves overwriting, or replacing, data).” *Id.* 5–6 (citing Ex. 1001, 6:9–21). As Patent Owner further argues, the disclosure regarding Figure 2 of Papasakellariou also recognizes this distinction as it “discloses two separate steps for multiplexing data bits and CQI bits (element 220 in Figure 2) and puncturing data bits to insert ACK/NA[]K (element 230 in Figure 2).” Prelim. Resp. 60; *see also* Ex. 1006, 2:6–10. We agree with Patent Owner that the “*Papasakellariou Provisional* [i.e., the ’843 provisional] fails to make this critical distinction between multiplexing

IPR2018-00807  
Patent 8,102,833 B2

and puncturing” and that there is no equivalent or similar disclosure in the ’843 provisional corresponding to Figure 2 of Papasakellariou. Prelim. Resp. 59–60. In that regard, as Patent Owner argues, Figure 2 of the ’843 provisional shows “Coded data” and “Control bits” being combined at a box labeled “Puncture Data Insert Control.” Ex. 1007, 2. As Patent Owner also argues, the description of Figure 2 of the ’843 provisional “reinforces this use of the term ‘multiplex,’ labeling the figure ‘Multiplexing of Control and Data Signals’ and stating that ‘certain data bits . . . may be punctured and replaced by the control bits . . . . This time division multiplexing (TDM) between the control (ACK/NACK and or CQI) and data signals prior to the DFT is necessary to preserve the single carrier property of the transmission.” *Id.* Thus, we agree with Patent Owner that Figure 2 of the ’843 provisional, like Figure 3 of Papasakellariou, illustrates a single step (“Puncture Data Insert Control”), and this single-step process is different than the multi-step process disclosed in the ’833 patent and shown in Figure 2 of Papasakellariou, in which data signals and control signals are multiplexed before being punctured by ACK/NACK signals. *See* Prelim. Resp. 62.

In summary, for all the reasons discussed above, we agree with Patent Owner that Petitioner has failed to meet its burden to show that the ’843 provisional discloses the subject matter of Figure 2 of Papasakellariou on which Petitioner relies in the Petition to teach or suggest limitations [1a] and [1c]. Accordingly, we determine that Papasakellariou is not entitled to claim the benefit of the filing date of the ’843 provisional and that the effective filing date of Papasakellariou is June 4, 2008, which was the filing date of

IPR2018-00807  
Patent 8,102,833 B2

the application that issued as Papasakellariou, i.e., U.S. Patent No. 8,331,328.

Because the earliest effective filing date of Papasakellariou on June 4, 2008 does not predate the earliest effective filing date of the '833 patent on November 13, 2007, Petitioner has failed to demonstrate that Papasakellariou is prior art under § 102(e) to the '833 patent. Accordingly, Petitioner has also failed to demonstrate that the claims of the '833 patent would have been obvious over the combination of Papasakellariou, Cho, and Motorola.

### III. CONCLUSION

For the foregoing reasons, we determine Petitioner has not demonstrated a reasonable likelihood of success in proving that any one of claims 1–14 of the '833 patent are unpatentable based on the ground asserted in the Petition.

### IV. ORDER

Accordingly, it is

ORDERED that the Petition is denied, and no *inter partes* review is instituted.

IPR2018-00807  
Patent 8,102,833 B2

PETITIONER:

Peter P. Chen  
COVINGTON & BURLING LLP  
333 Twin Dolphin Drive  
Ste. 700  
Redwood Shores, CA 94065

David A. Garr  
Gregory S. Discher  
COVINGTON & BURLING LLP  
One CityCenter, 850 Tenth Street, NW  
Washington, DC 20001

PATENT OWNER:

Brent N. Bumgardner  
NELSON BUMGARDNER ALBRIGHTTON P. C.  
3131 West 7th Street, Ste. 300  
Fort Worth, TX 76107  
brent@nbafirm.com

UNITED STATES PATENT AND TRADEMARK OFFICE  
**CERTIFICATE OF CORRECTION**

PATENT NO. : 8,102,833 B2  
APPLICATION NO. : 12/209136  
DATED : January 24, 2012  
INVENTOR(S) : Lee et al.

Page 1 of 1

It is certified that error appears in the above-identified patent and that said Letters Patent is hereby corrected as shown below:

In the Specification

Column 10, Line 8-12, delete “wherein the columns and the rows of the 2-dimensional resource matrix correspond to single carrier frequency divisional multiple access (SC-FDMA) and subcarriers for each SC-FDMA symbol,” and insert -- wherein the columns and the rows of the 2-dimensional resource matrix correspond to single carrier frequency divisional multiple access (SC-FDMA) symbols and subcarriers for each SC-FDMA symbol, --, therefor.

Signed and Sealed this  
Seventh Day of November, 2017



Joseph Matal  
*Performing the Functions and Duties of the  
Under Secretary of Commerce for Intellectual Property and  
Director of the United States Patent and Trademark Office*

**UNITED STATES PATENT AND TRADEMARK OFFICE  
CERTIFICATE OF CORRECTION**Page 1 of 1

PATENT NO. : 8,102,833

APPLICATION NO.: 12/209,136

ISSUE DATE : January 24, 2012

INVENTOR(S) : LEE, et al.

It is certified that an error appears or errors appear in the above-identified patent and that said Letters Patent is hereby corrected as shown below:

Col. 10, beginning on line 8, delete "wherein the columns and the rows of the 2-dimensional resource matrix correspond to single carrier frequency divisional multiple access (SC-FDMA) and subcarriers for each SC-FDMA symbol," and insert -- wherein the columns and the rows of the 2-dimensional resource matrix correspond to single carrier frequency divisional multiple access (SC-FDMA) symbols and subcarriers for each SC-FDMA symbol, --, therefor.

**MAILING ADDRESS OF SENDER (Please do not use Customer Number below):**

PanOptis Patent Management  
7160 Dallas Pkwy. Suite 250  
Plano, TX 75024

This collection of information is required by 37 CFR 1.322, 1.323, and 1.324. The information is required to obtain or retain a benefit by the public which is to file (and by the USPTO to process) an application. Confidentiality is governed by 35 U.S.C. 122 and 37 CFR 1.14. This collection is estimated to take 1.0 hour to complete, including gathering, preparing, and submitting the completed application form to the USPTO. Time will vary depending upon the individual case. Any comments on the amount of time you require to complete this form and/or suggestions for reducing this burden, should be sent to the Chief Information Officer, U.S. Patent and Trademark Office, U.S. Department of Commerce, P.O. Box 1450, Alexandria, VA 22313-1450. DO NOT SEND FEES OR COMPLETED FORMS TO THIS ADDRESS. **SEND TO: Attention Certificate of Corrections Branch, Commissioner for Patents, P.O. Box 1450, Alexandria, VA 22313-1450.**

*If you need assistance in completing the form, call 1-800-PTO-9199 and select option 2.*

## Privacy Act Statement

The **Privacy Act of 1974 (P.L. 93-579)** requires that you be given certain information in connection with your submission of the attached form related to a patent application or patent. Accordingly, pursuant to the requirements of the Act, please be advised that: (1) the general authority for the collection of this information is 35 U.S.C. 2(b)(2); (2) furnishing of the information solicited is voluntary; and (3) the principal purpose for which the information is used by the U.S. Patent and Trademark Office is to process and/or examine your submission related to a patent application or patent. If you do not furnish the requested information, the U.S. Patent and Trademark Office may not be able to process and/or examine your submission, which may result in termination of proceedings or abandonment of the application or expiration of the patent.

The information provided by you in this form will be subject to the following routine uses:

1. The information on this form will be treated confidentially to the extent allowed under the Freedom of Information Act (5 U.S.C. 552) and the Privacy Act (5 U.S.C. 552a). Records from this system of records may be disclosed to the Department of Justice to determine whether disclosure of these records is required by the Freedom of Information Act.
2. A record from this system of records may be disclosed, as a routine use, in the course of presenting evidence to a court, magistrate, or administrative tribunal, including disclosures to opposing counsel in the course of settlement negotiations.
3. A record in this system of records may be disclosed, as a routine use, to a Member of Congress submitting a request involving an individual, to whom the record pertains, when the individual has requested assistance from the Member with respect to the subject matter of the record.
4. A record in this system of records may be disclosed, as a routine use, to a contractor of the Agency having need for the information in order to perform a contract. Recipients of information shall be required to comply with the requirements of the Privacy Act of 1974, as amended, pursuant to 5 U.S.C. 552a(m).
5. A record related to an International Application filed under the Patent Cooperation Treaty in this system of records may be disclosed, as a routine use, to the International Bureau of the World Intellectual Property Organization, pursuant to the Patent Cooperation Treaty.
6. A record in this system of records may be disclosed, as a routine use, to another federal agency for purposes of National Security review (35 U.S.C. 181) and for review pursuant to the Atomic Energy Act (42 U.S.C. 218(c)).
7. A record from this system of records may be disclosed, as a routine use, to the Administrator, General Services, or his/her designee, during an inspection of records conducted by GSA as part of that agency's responsibility to recommend improvements in records management practices and programs, under authority of 44 U.S.C. 2904 and 2906. Such disclosure shall be made in accordance with the GSA regulations governing inspection of records for this purpose, and any other relevant (*i.e.*, GSA or Commerce) directive. Such disclosure shall not be used to make determinations about individuals.
8. A record from this system of records may be disclosed, as a routine use, to the public after either publication of the application pursuant to 35 U.S.C. 122(b) or issuance of a patent pursuant to 35 U.S.C. 151. Further, a record may be disclosed, subject to the limitations of 37 CFR 1.14, as a routine use, to the public if the record was filed in an application which became abandoned or in which the proceedings were terminated and which application is referenced by either a published application, an application open to public inspection or an issued patent.
9. A record from this system of records may be disclosed, as a routine use, to a Federal, State, or local law enforcement agency, if the USPTO becomes aware of a violation or potential violation of law or regulation.

## Electronic Patent Application Fee Transmittal

<b>Application Number:</b>	12209136			
<b>Filing Date:</b>	11-Sep-2008			
<b>Title of Invention:</b>	METHOD FOR TRANSMITTING UPLINK SIGNALS			
<b>First Named Inventor/Applicant Name:</b>	Dae Won Lee			
<b>Filer:</b>	Kenneth A. McClure/Kara Coffman			
<b>Attorney Docket Number:</b>	6095-0144			
Filed as Large Entity				
<b>Filing Fees for Utility under 35 USC 111(a)</b>				
<b>Description</b>	<b>Fee Code</b>	<b>Quantity</b>	<b>Amount</b>	<b>Sub-Total in USD(\$)</b>
<b>Basic Filing:</b>				
<b>Pages:</b>				
<b>Claims:</b>				
<b>Miscellaneous-Filing:</b>				
<b>Petition:</b>				
<b>Patent-Appeals-and-Interference:</b>				
<b>Post-Allowance-and-Post-Issuance:</b>				
Certificate of correction	1811	1	100	100



Description	Fee Code	Quantity	Amount	Sub-Total in USD(\$)
<b>Extension-of-Time:</b>				
<b>Miscellaneous:</b>				
<b>Total in USD (\$)</b>				<b>100</b>

## Electronic Acknowledgement Receipt

<b>EFS ID:</b>	30620306
<b>Application Number:</b>	12209136
<b>International Application Number:</b>	
<b>Confirmation Number:</b>	3897
<b>Title of Invention:</b>	METHOD FOR TRANSMITTING UPLINK SIGNALS
<b>First Named Inventor/Applicant Name:</b>	Dae Won Lee
<b>Customer Number:</b>	23117
<b>Filer:</b>	Kenneth A. McClure/Kara Coffman
<b>Filer Authorized By:</b>	Kenneth A. McClure
<b>Attorney Docket Number:</b>	6095-0144
<b>Receipt Date:</b>	11-OCT-2017
<b>Filing Date:</b>	11-SEP-2008
<b>Time Stamp:</b>	11:03:36
<b>Application Type:</b>	Utility under 35 USC 111(a)

### Payment information:

Submitted with Payment	yes
Payment Type	CARD
Payment was successfully received in RAM	\$100
RAM confirmation Number	101117INTEFSW11041200
Deposit Account	
Authorized User	

The Director of the USPTO is hereby authorized to charge indicated fees and credit any overpayment as follows:

**File Listing:**

Document Number	Document Description	File Name	File Size(Bytes)/ Message Digest	Multi Part /.zip	Pages (if appl.)
1	Transmittal Letter	ML6US4_Request_for_Certificate_of_Correction.pdf	82556 b0ffdef8a5f3e7660dca90c18d72ec88c4b69b9	no	2

**Warnings:****Information:**

2	Request for Certificate of Correction	ML6US4_PTO-1050.pdf	159826 54ade7ed012450891ea399276b61ec266a423531	no	2
---	---------------------------------------	---------------------	--	----	---

**Warnings:****Information:**

3	Fee Worksheet (SB06)	fee-info.pdf	30498 a07097d7c5f87545d2a0293c760edc3c9f72bf65	no	2
---	----------------------	--------------	---	----	---

**Warnings:****Information:**

<b>Total Files Size (in bytes):</b>	272880
-------------------------------------	--------

**This Acknowledgement Receipt evidences receipt on the noted date by the USPTO of the indicated documents, characterized by the applicant, and including page counts, where applicable. It serves as evidence of receipt similar to a Post Card, as described in MPEP 503.**

**New Applications Under 35 U.S.C. 111**

**If a new application is being filed and the application includes the necessary components for a filing date (see 37 CFR 1.53(b)-(d) and MPEP 506), a Filing Receipt (37 CFR 1.54) will be issued in due course and the date shown on this Acknowledgement Receipt will establish the filing date of the application.**

**National Stage of an International Application under 35 U.S.C. 371**

**If a timely submission to enter the national stage of an international application is compliant with the conditions of 35 U.S.C. 371 and other applicable requirements a Form PCT/DO/EO/903 indicating acceptance of the application as a national stage submission under 35 U.S.C. 371 will be issued in addition to the Filing Receipt, in due course.**

**New International Application Filed with the USPTO as a Receiving Office**

**If a new international application is being filed and the international application includes the necessary components for an international filing date (see PCT Article 11 and MPEP 1810), a Notification of the International Application Number and of the International Filing Date (Form PCT/RO/105) will be issued in due course, subject to prescriptions concerning national security, and the date shown on this Acknowledgement Receipt will establish the international filing date of the application.**

LEE, et al.  
Patent No. 8,102,833

**IN THE UNITED STATES PATENT AND TRADEMARK OFFICE**

In re application of:	Dae Won Lee, et al.	§	Confirmation No:	3897
		§		
Patent No.:	8,102,833	§	Examiner:	Yeung, Mang Hang
Application No.:	12/209,136	§		
		§		
Issued:	January 24, 2012	§	Art Unit:	2463
		§		
Attorney Docket No: ML6US4 / 6095-0144				
Customer No.: 47391				

For: METHOD FOR TRANSMITTING UPLINK SIGNALS

Commissioner for Patents  
P.O. Box 1450  
Alexandria, VA 22313-1450

Sir:

**REQUEST FOR A CERTIFICATE OF CORRECTION**

The following is a request for a Certificate of Correction in Application Number 12/209,136, now Patent Number 8,102,833.

A certificate of correction under 35 USC 254 is respectfully requested in the above-identified patent.

The errors were the fault of the applicant, therefore, the fee of \$100.00 is submitted herewith securing issuance of the Certificate.

The exact locations where the errors appear in the patent and patent application are as follows:

Claim 8, Column 10, beginning on Line 8, "wherein the columns and the rows of the 2-dimensional resource matrix correspond to single carrier frequency divisional multiple access (SC-FDMA) and subcarriers for each SC-FDMA symbol," should read --wherein the columns and the rows of the 2-dimensional resource matrix correspond to single carrier frequency divisional multiple access (SC-FDMA) symbols and subcarriers for each SC-FDMA symbol, -

-.

LEE, et al.  
Patent No. 8,102,833

The requested corrections are included on the attached Form PTO 1050.

Respectfully submitted,

/Kenneth A. McClure/

Kenneth A. McClure  
Registration No. 62,886

Date: October 11, 2017

PanOptis Patent Management, LLC  
7160 Dallas Pkwy.  
Suite 250  
Plano, TX 75024

Telephone: (214) 744-5000

Customer No.: 47391

**Certificate of Service**

I hereby certify that this correspondence is being filed with  
the U.S. Patent and Trademark Office via EFS-Web on  
October 11, 2017

/Kara Coffman/  
Kara Coffman

AO 120 (Rev. 08/10)

TO: <b>Mail Stop 8</b> <b>Director of the U.S. Patent and Trademark Office</b> <b>P.O. Box 1450</b> <b>Alexandria, VA 22313-1450</b>	<b>REPORT ON THE</b> <b>FILING OR DETERMINATION OF AN</b> <b>ACTION REGARDING A PATENT OR</b> <b>TRADEMARK</b>
---	---

In Compliance with 35 U.S.C. § 290 and/or 15 U.S.C. § 1116 you are hereby advised that a court action has been filed in the U.S. District Court Eastern District of Texas, Marshall Division on the following

Trademarks or  Patents. (  the patent action involves 35 U.S.C. § 292.):

DOCKET NO. 2:16-cv-59	DATE FILED 1/17/2016	U.S. DISTRICT COURT Eastern District of Texas, Marshall Division
PLAINTIFF OPTIS CELLULAR TECHNOLOGY, LLC and PANOPTIS PATENT MANAGEMENT, LLC		DEFENDANT KYOCERA COMMUNICATIONS, INC., KYOCERA INTERNATIONAL, INC. and KYOCERA CORPORATION
PATENT OR TRADEMARK NO.	DATE OF PATENT OR TRADEMARK	HOLDER OF PATENT OR TRADEMARK
1 8,019,332	9/13/2011	OPTIS CELLULAR TECHNOLOGY, LLC
2 8,102,833	1/24/2012	OPTIS CELLULAR TECHNOLOGY, LLC
3 8,437,293	5/7/2013	OPTIS CELLULAR TECHNOLOGY, LLC
4 8,174,506	5/8/2012	OPTIS CELLULAR TECHNOLOGY, LLC
5		

In the above—entitled case, the following patent(s)/ trademark(s) have been included:

DATE INCLUDED	INCLUDED BY	<input type="checkbox"/> Amendment <input type="checkbox"/> Answer <input type="checkbox"/> Cross Bill <input type="checkbox"/> Other Pleading
PATENT OR TRADEMARK NO.	DATE OF PATENT OR TRADEMARK	HOLDER OF PATENT OR TRADEMARK
1		
2		
3		
4		
5		

In the above—entitled case, the following decision has been rendered or judgement issued:

DECISION/JUDGEMENT  <p style="text-align: center;">Dismissing Kyocera etal with prejudice</p>
---

CLERK <i>David A. O'foole</i>	(BY) DEPUTY CLERK ch	DATE 4/27/17
----------------------------------	-------------------------	-----------------

Copy 1—Upon initiation of action, mail this copy to Director    Copy 3—Upon termination of action, mail this copy to Director  
 Copy 2—Upon filing document adding patent(s), mail this copy to Director    Copy 4—Case file copy

AO 120 (Rev. 08/10)

TO: <b>Mail Stop 8</b> <b>Director of the U.S. Patent and Trademark Office</b> <b>P.O. Box 1450</b> <b>Alexandria, VA 22313-1450</b>	<b>REPORT ON THE</b> <b>FILING OR DETERMINATION OF AN</b> <b>ACTION REGARDING A PATENT OR</b> <b>TRADEMARK</b>
---	---

In Compliance with 35 U.S.C. § 290 and/or 15 U.S.C. § 1116 you are hereby advised that a court action has been filed in the U.S. District Court Eastern District of Texas, Marshall Division on the following

Trademarks or  Patents. (  the patent action involves 35 U.S.C. § 292.):

DOCKET NO. 2:16-cv-60	DATE FILED 1/17/2016	U.S. DISTRICT COURT Eastern District of Texas, Marshall Division
PLAINTIFF OPTIS CELLULAR TECHNOLOGY, LLC and PANOPTIS PATENT MANAGEMENT, LLC		DEFENDANT BLACKBERRY LIMITED and BLACKBERRY CORPORATION
PATENT OR TRADEMARK NO.	DATE OF PATENT OR TRADEMARK	HOLDER OF PATENT OR TRADEMARK
1 8,019,332	9/13/2011	OPTIS CELLULAR TECHNOLOGY, LLC
2 8,102,833	1/24/2012	OPTIS CELLULAR TECHNOLOGY, LLC
3 8,437,293	5/7/2013	OPTIS CELLULAR TECHNOLOGY, LLC
4 8,174,506	5/8/2012	OPTIS CELLULAR TECHNOLOGY, LLC
5		

In the above—entitled case, the following patent(s)/ trademark(s) have been included:

DATE INCLUDED	INCLUDED BY <input type="checkbox"/> Amendment <input type="checkbox"/> Answer <input type="checkbox"/> Cross Bill <input type="checkbox"/> Other Pleading	
PATENT OR TRADEMARK NO.	DATE OF PATENT OR TRADEMARK	HOLDER OF PATENT OR TRADEMARK
1		
2		
3		
4		
5		

In the above—entitled case, the following decision has been rendered or judgement issued:

DECISION/JUDGEMENT  <b>ORDERED that all claims brought by PanOptis against BlackBerry in this action are dismissed without prejudice</b>
--

CLERK <i>David A. O'Poole</i>	(BY) DEPUTY CLERK ch	DATE <b>4/27/17</b>
----------------------------------	-------------------------	------------------------

Copy 1—Upon initiation of action, mail this copy to Director Copy 3—Upon termination of action, mail this copy to Director  
 Copy 2—Upon filing document adding patent(s), mail this copy to Director Copy 4—Case file copy

AO 120 (Rev. 08/10)

<b>TO:</b> Mail Stop 8 Director of the U.S. Patent and Trademark Office P.O. Box 1450 Alexandria, VA 22313-1450	<b>REPORT ON THE                  FILING OR DETERMINATION OF AN                  ACTION REGARDING A PATENT OR                  TRADEMARK</b>
---	--

In Compliance with 35 U.S.C. § 290 and/or 15 U.S.C. § 1116 you are hereby advised that a court action has been filed in the U.S. District Court \_\_\_\_\_ for the Eastern District of Texas, Marshall Division \_\_\_\_\_ on the following  
 Trademarks or  Patents. (  the patent action involves 35 U.S.C. § 292.):

DOCKET NO. 2:16-cv-58	DATE FILED 1/17/2016	U.S. DISTRICT COURT Eastern District of Texas, Marshall Division
PLAINTIFF OPTIS CELLULAR TECHNOLOGY, LLC and PANOPTIS PATENT MANAGEMENT, LLC		DEFENDANT ZTE CORPORATION and ZTE (USA) INC.
PATENT OR TRADEMARK NO.	DATE OF PATENT OR TRADEMARK	HOLDER OF PATENT OR TRADEMARK
1 8,019,332	9/13/2011	OPTIS CELLULAR TECHNOLOGY, LLC
2 8,102,833	1/24/2012	OPTIS CELLULAR TECHNOLOGY, LLC
3 8,437,293	5/7/2013	OPTIS CELLULAR TECHNOLOGY, LLC
4 8,174,506	5/8/2012	OPTIS CELLULAR TECHNOLOGY, LLC
5		

In the above—entitled case, the following patent(s)/ trademark(s) have been included:

DATE INCLUDED	INCLUDED BY <input type="checkbox"/> Amendment <input type="checkbox"/> Answer <input type="checkbox"/> Cross Bill <input type="checkbox"/> Other Pleading		
PATENT OR TRADEMARK NO.	DATE OF PATENT OR TRADEMARK	HOLDER OF PATENT OR TRADEMARK	
1			
2			
3			
4			
5			

In the above—entitled case, the following decision has been rendered or judgement issued:

DECISION/JUDGEMENT ORDERED that all claims brought by PanOptis in this action are dismissed without prejudice.
---

CLERK <i>David A. O'Toole</i>	(BY) DEPUTY CLERK Charlene Hinton	DATE 5/13/16
----------------------------------	--------------------------------------	-----------------

Copy 1—Upon initiation of action, mail this copy to Director    Copy 3—Upon termination of action, mail this copy to Director  
 Copy 2—Upon filing document adding patent(s), mail this copy to Director    Copy 4—Case file copy



AO 120 (Rev. 08/10)

<b>TO:</b> <p style="text-align: center;"><b>Mail Stop 8</b>  <b>Director of the U.S. Patent and Trademark Office</b>  <b>P.O. Box 1450</b>  <b>Alexandria, VA 22313-1450</b></p>	<b>REPORT ON THE          FILING OR DETERMINATION OF AN          ACTION REGARDING A PATENT OR          TRADEMARK</b>
--	--

In Compliance with 35 U.S.C. § 290 and/or 15 U.S.C. § 1116 you are hereby advised that a court action has been filed in the U.S. District Court \_\_\_\_\_ for the **Eastern District of Texas, Marshall Division** on the following

Trademarks or  Patents. (  the patent action involves 35 U.S.C. § 292.):

DOCKET NO. 2:16-cv-58	DATE FILED 1/17/2016	U.S. DISTRICT COURT Eastern District of Texas, Marshall Division
PLAINTIFF OPTIS CELLULAR TECHNOLOGY, LLC and PANOPTIS PATENT MANAGEMENT, LLC		DEFENDANT ZTE CORPORATION and ZTE (USA) INC.
PATENT OR TRADEMARK NO.	DATE OF PATENT OR TRADEMARK	HOLDER OF PATENT OR TRADEMARK
1 8,019,332	9/13/2011	OPTIS CELLULAR TECHNOLOGY, LLC
2 8,102,833	1/24/2012	OPTIS CELLULAR TECHNOLOGY, LLC
3 8,437,293	5/7/2013	OPTIS CELLULAR TECHNOLOGY, LLC
4 8,174,506	5/8/2012	OPTIS CELLULAR TECHNOLOGY, LLC
5		

In the above—entitled case, the following patent(s)/ trademark(s) have been included:

DATE INCLUDED	INCLUDED BY <input type="checkbox"/> Amendment <input type="checkbox"/> Answer <input type="checkbox"/> Cross Bill <input type="checkbox"/> Other Pleading	
PATENT OR TRADEMARK NO.	DATE OF PATENT OR TRADEMARK	HOLDER OF PATENT OR TRADEMARK
1		
2		
3		
4		
5		

In the above—entitled case, the following decision has been rendered or judgement issued:

DECISION/JUDGEMENT
--------------------

CLERK	(BY) DEPUTY CLERK	DATE
-------	-------------------	------

Copy 1—Upon initiation of action, mail this copy to Director    Copy 3—Upon termination of action, mail this copy to Director  
 Copy 2—Upon filing document adding patent(s), mail this copy to Director    Copy 4—Case file copy

AO 120 (Rev. 08/10)

<b>TO:</b> <p style="text-align: center;"><b>Mail Stop 8</b>  <b>Director of the U.S. Patent and Trademark Office</b>  <b>P.O. Box 1450</b>  <b>Alexandria, VA 22313-1450</b></p>	<b>REPORT ON THE          FILING OR DETERMINATION OF AN          ACTION REGARDING A PATENT OR          TRADEMARK</b>
--	--

In Compliance with 35 U.S.C. § 290 and/or 15 U.S.C. § 1116 you are hereby advised that a court action has been filed in the U.S. District Court Eastern District of Texas, Marshall Division on the following

Trademarks or  Patents. (  the patent action involves 35 U.S.C. § 292.);

DOCKET NO. 2:16-cv-59	DATE FILED 1/17/2016	U.S. DISTRICT COURT Eastern District of Texas, Marshall Division
PLAINTIFF OPTIS CELLULAR TECHNOLOGY, LLC and PANOPTIS PATENT MANAGEMENT, LLC		DEFENDANT KYOCERA COMMUNICATIONS, INC., KYOCERA INTERNATIONAL, INC. and KYOCERA CORPORATION
PATENT OR TRADEMARK NO.	DATE OF PATENT OR TRADEMARK	HOLDER OF PATENT OR TRADEMARK
1 8,019,332	9/13/2011	OPTIS CELLULAR TECHNOLOGY, LLC
2 8,102,833	1/24/2012	OPTIS CELLULAR TECHNOLOGY, LLC
3 8,437,293	5/7/2013	OPTIS CELLULAR TECHNOLOGY, LLC
4 8,174,506	5/8/2012	OPTIS CELLULAR TECHNOLOGY, LLC
5		

In the above—entitled case, the following patent(s)/ trademark(s) have been included:

DATE INCLUDED	INCLUDED BY	
	<input type="checkbox"/> Amendment <input type="checkbox"/> Answer <input type="checkbox"/> Cross Bill <input type="checkbox"/> Other Pleading	
PATENT OR TRADEMARK NO.	DATE OF PATENT OR TRADEMARK	HOLDER OF PATENT OR TRADEMARK
1		
2		
3		
4		
5		

In the above—entitled case, the following decision has been rendered or judgement issued:

DECISION/JUDGEMENT
--------------------

CLERK	(BY) DEPUTY CLERK	DATE
-------	-------------------	------

Copy 1—Upon initiation of action, mail this copy to Director    Copy 3—Upon termination of action, mail this copy to Director  
 Copy 2—Upon filing document adding patent(s), mail this copy to Director    Copy 4—Case file copy

AO 120 (Rev. 08/10)

<b>TO:</b> <p style="text-align: center;"><b>Mail Stop 8</b>  <b>Director of the U.S. Patent and Trademark Office</b>  <b>P.O. Box 1450</b>  <b>Alexandria, VA 22313-1450</b></p>	<b>REPORT ON THE          FILING OR DETERMINATION OF AN          ACTION REGARDING A PATENT OR          TRADEMARK</b>
--	--

In Compliance with 35 U.S.C. § 290 and/or 15 U.S.C. § 1116 you are hereby advised that a court action has been filed in the U.S. District Court Eastern District of Texas, Marshall Division on the following

Trademarks or  Patents. (  the patent action involves 35 U.S.C. § 292.):

DOCKET NO. 2:16-cv-60	DATE FILED 1/17/2016	U.S. DISTRICT COURT Eastern District of Texas, Marshall Division
PLAINTIFF OPTIS CELLULAR TECHNOLOGY, LLC and PANOPTIS PATENT MANAGEMENT, LLC		DEFENDANT BLACKBERRY LIMITED and BLACKBERRY CORPORATION
PATENT OR TRADEMARK NO.	DATE OF PATENT OR TRADEMARK	HOLDER OF PATENT OR TRADEMARK
1 8,019,332	9/13/2011	OPTIS CELLULAR TECHNOLOGY, LLC
2 8,102,833	1/24/2012	OPTIS CELLULAR TECHNOLOGY, LLC
3 8,437,293	5/7/2013	OPTIS CELLULAR TECHNOLOGY, LLC
4 8,174,506	5/8/2012	OPTIS CELLULAR TECHNOLOGY, LLC
5		

In the above—entitled case, the following patent(s)/ trademark(s) have been included:

DATE INCLUDED	INCLUDED BY <input type="checkbox"/> Amendment <input type="checkbox"/> Answer <input type="checkbox"/> Cross Bill <input type="checkbox"/> Other Pleading		
PATENT OR TRADEMARK NO.	DATE OF PATENT OR TRADEMARK	HOLDER OF PATENT OR TRADEMARK	
1			
2			
3			
4			
5			

In the above—entitled case, the following decision has been rendered or judgement issued:

DECISION/JUDGEMENT
--------------------

CLERK	(BY) DEPUTY CLERK	DATE
-------	-------------------	------

Copy 1—Upon initiation of action, mail this copy to Director    Copy 3—Upon termination of action, mail this copy to Director  
 Copy 2—Upon filing document adding patent(s), mail this copy to Director    Copy 4—Case file copy

AO 120 (Rev. 08/10)

<b>TO:</b> <b>Mail Stop 8</b> <b>Director of the U.S. Patent and Trademark Office</b> <b>P.O. Box 1450</b> <b>Alexandria, VA 22313-1450</b>	<b>REPORT ON THE</b> <b>FILING OR DETERMINATION OF AN</b> <b>ACTION REGARDING A PATENT OR</b> <b>TRADEMARK</b>
--	---

In Compliance with 35 U.S.C. § 290 and/or 15 U.S.C. § 1116 you are hereby advised that a court action has been filed in the U.S. District Court Eastern District of Texas, Marshall Division on the following

Trademarks or  Patents. (  the patent action involves 35 U.S.C. § 292.):

DOCKET NO. 2:16-cv-60	DATE FILED 1/17/2016	U.S. DISTRICT COURT Eastern District of Texas, Marshall Division
PLAINTIFF OPTIS CELLULAR TECHNOLOGY, LLC and PANOPTIS PATENT MANAGEMENT, LLC		DEFENDANT BLACKBERRY LIMITED and BLACKBERRY CORPORATION
PATENT OR TRADEMARK NO.	DATE OF PATENT OR TRADEMARK	HOLDER OF PATENT OR TRADEMARK
1 8,019,332	9/13/2011	OPTIS CELLULAR TECHNOLOGY, LLC
2 8,102,833	1/24/2012	OPTIS CELLULAR TECHNOLOGY, LLC
3 8,437,293	5/7/2013	OPTIS CELLULAR TECHNOLOGY, LLC
4 8,174,506	5/8/2012	OPTIS CELLULAR TECHNOLOGY, LLC
5		

In the above—entitled case, the following patent(s)/ trademark(s) have been included:

DATE INCLUDED	INCLUDED BY <input type="checkbox"/> Amendment <input type="checkbox"/> Answer <input type="checkbox"/> Cross Bill <input type="checkbox"/> Other Pleading	
PATENT OR TRADEMARK NO.	DATE OF PATENT OR TRADEMARK	HOLDER OF PATENT OR TRADEMARK
1		
2		
3		
4		
5		

In the above—entitled case, the following decision has been rendered or judgement issued:

DECISION/JUDGEMENT
--------------------

CLERK	(BY) DEPUTY CLERK	DATE
-------	-------------------	------

Copy 1—Upon initiation of action, mail this copy to Director Copy 3—Upon termination of action, mail this copy to Director  
 Copy 2—Upon filing document adding patent(s), mail this copy to Director Copy 4—Case file copy

AO 120 (Rev. 08/10)

<b>TO:</b> <b>Mail Stop 8</b> <b>Director of the U.S. Patent and Trademark Office</b> <b>P.O. Box 1450</b> <b>Alexandria, VA 22313-1450</b>	<b>REPORT ON THE</b> <b>FILING OR DETERMINATION OF AN</b> <b>ACTION REGARDING A PATENT OR</b> <b>TRADEMARK</b>
--	---

In Compliance with 35 U.S.C. § 290 and/or 15 U.S.C. § 1116 you are hereby advised that a court action has been filed in the U.S. District Court \_\_\_\_\_ for the Eastern District of Texas, Marshall Division \_\_\_\_\_ on the following

Trademarks or  Patents. (  the patent action involves 35 U.S.C. § 292.):

DOCKET NO. 2:16-cv-58	DATE FILED 1/17/2016	U.S. DISTRICT COURT Eastern District of Texas, Marshall Division
PLAINTIFF OPTIS CELLULAR TECHNOLOGY, LLC and PANOPTIS PATENT MANAGEMENT, LLC		DEFENDANT ZTE CORPORATION and ZTE (USA) INC.
PATENT OR TRADEMARK NO.	DATE OF PATENT OR TRADEMARK	HOLDER OF PATENT OR TRADEMARK
1 8,019,332	9/13/2011	OPTIS CELLULAR TECHNOLOGY, LLC
2 8,102,833	1/24/2012	OPTIS CELLULAR TECHNOLOGY, LLC
3 8,437,293	5/7/2013	OPTIS CELLULAR TECHNOLOGY, LLC
4 8,174,506	5/8/2012	OPTIS CELLULAR TECHNOLOGY, LLC
5		

In the above—entitled case, the following patent(s)/ trademark(s) have been included:

DATE INCLUDED	INCLUDED BY <input type="checkbox"/> Amendment <input type="checkbox"/> Answer <input type="checkbox"/> Cross Bill <input type="checkbox"/> Other Pleading	
PATENT OR TRADEMARK NO.	DATE OF PATENT OR TRADEMARK	HOLDER OF PATENT OR TRADEMARK
1		
2		
3		
4		
5		

In the above—entitled case, the following decision has been rendered or judgement issued:

DECISION/JUDGEMENT
--------------------

CLERK	(BY) DEPUTY CLERK	DATE
-------	-------------------	------

Copy 1—Upon initiation of action, mail this copy to Director Copy 3—Upon termination of action, mail this copy to Director  
 Copy 2—Upon filing document adding patent(s), mail this copy to Director Copy 4—Case file copy

AO 120 (Rev. 08/10)

<b>TO:</b> <b>Mail Stop 8</b> <b>Director of the U.S. Patent and Trademark Office</b> <b>P.O. Box 1450</b> <b>Alexandria, VA 22313-1450</b>	<b>REPORT ON THE</b> <b>FILING OR DETERMINATION OF AN</b> <b>ACTION REGARDING A PATENT OR</b> <b>TRADEMARK</b>
--	---

In Compliance with 35 U.S.C. § 290 and/or 15 U.S.C. § 1116 you are hereby advised that a court action has been filed in the U.S. District Court Eastern District of Texas, Marshall Division on the following

Trademarks or  Patents. (  the patent action involves 35 U.S.C. § 292.):

DOCKET NO. 2:16-cv-59	DATE FILED 1/17/2016	U.S. DISTRICT COURT Eastern District of Texas, Marshall Division
PLAINTIFF		DEFENDANT
OPTIS CELLULAR TECHNOLOGY, LLC and PANOPTIS PATENT MANAGEMENT, LLC		KYOCERA COMMUNICATIONS, INC., KYOCERA INTERNATIONAL, INC. and KYOCERA CORPORATION
PATENT OR TRADEMARK NO.	DATE OF PATENT OR TRADEMARK	HOLDER OF PATENT OR TRADEMARK
1 8,019,332	9/13/2011	OPTIS CELLULAR TECHNOLOGY, LLC
2 8,102,833	1/24/2012	OPTIS CELLULAR TECHNOLOGY, LLC
3 8,437,293	5/7/2013	OPTIS CELLULAR TECHNOLOGY, LLC
4 8,174,506	5/8/2012	OPTIS CELLULAR TECHNOLOGY, LLC
5		

In the above—entitled case, the following patent(s)/ trademark(s) have been included:

DATE INCLUDED	INCLUDED BY	
	<input type="checkbox"/> Amendment <input type="checkbox"/> Answer <input type="checkbox"/> Cross Bill <input type="checkbox"/> Other Pleading	
PATENT OR TRADEMARK NO.	DATE OF PATENT OR TRADEMARK	HOLDER OF PATENT OR TRADEMARK
1		
2		
3		
4		
5		

In the above—entitled case, the following decision has been rendered or judgement issued:

DECISION/JUDGEMENT
--------------------

CLERK	(BY) DEPUTY CLERK	DATE
-------	-------------------	------

Copy 1—Upon initiation of action, mail this copy to Director    Copy 3—Upon termination of action, mail this copy to Director  
 Copy 2—Upon filing document adding patent(s), mail this copy to Director    Copy 4—Case file copy



---

**UNITED STATES PATENT AND TRADEMARK OFFICE**

---

UNITED STATES DEPARTMENT OF COMMERCE  
**United States Patent and Trademark Office**  
 Address: COMMISSIONER FOR PATENTS  
 P.O. Box 1450  
 Alexandria, Virginia 22313-1450  
 www.uspto.gov

APPLICATION NUMBER	FILING OR 371(C) DATE	FIRST NAMED APPLICANT	ATTY. DOCKET NO./TITLE
12/209,136	09/11/2008	Dae Won Lee	2101-3573

**CONFIRMATION NO. 3897****POA ACCEPTANCE LETTER**

23117  
 NIXON & VANDERHYE, PC  
 901 NORTH GLEBE ROAD, 11TH FLOOR  
 ARLINGTON, VA 22203



Date Mailed: 05/27/2014

**NOTICE OF ACCEPTANCE OF POWER OF ATTORNEY**

This is in response to the Power of Attorney filed 05/13/2014.

The Power of Attorney in this application is accepted. Correspondence in this application will be mailed to the above address as provided by 37 CFR 1.33.

/sleutchit/

---

Office of Data Management, Application Assistance Unit (571) 272-4000, or (571) 272-4200, or 1-888-786-0101

**“FEE ADDRESS” INDICATION FORM**

**Address to:**  
**Mail Stop M Correspondence**  
**Commissioner for Patents**  
**P.O. Box 1450**  
**Alexandria, VA 22313-1450**

**Fax to:**  
**571-273-6500**

- OR -

**INSTRUCTIONS:** The issue fee must have been paid for application(s) listed on this form. In addition, only an address represented by a Customer Number can be established as the fee address for maintenance fee purposes (hereafter, fee address). A fee address should be established when correspondence related to maintenance fees should be mailed to a different address than the correspondence address for the application. **When to check the first box below:** If you have a Customer Number to represent the fee address. **When to check the second box below:** If you have no Customer Number representing the desired fee address, in which case a completed Request for Customer Number (PTO/SB/125) must be attached to this form. For more information on Customer Numbers, see the Manual of Patent Examining Procedure (MPEP) § 403.

For the following listed application(s), please recognize as the “Fee Address” under the provisions of 37 CFR 1.363 the address associated with:

Customer Number: 000204

**OR**

The attached Request for Customer Number (PTO/SB/125) form.

PATENT NUMBER <small>(if known)</small>	APPLICATION NUMBER
8102833	12/209136

Completed by (check one):

Applicant/Inventor /John R. Lastova/  
\_\_\_\_\_  
Signature

Attorney or Agent of record 33,149 John R. Lastova  
\_\_\_\_\_  
Typed or printed name  
(Reg. No.)

Assignee of record of the entire interest. See 37 CFR 3.71. 703-816-4000  
\_\_\_\_\_  
Requester's telephone number  
Statement under 37 CFR 3.73(b) is enclosed.

Assignee recorded at Reel \_\_\_\_\_ Frame \_\_\_\_\_ May 19, 2014  
\_\_\_\_\_  
Date

NOTE: Signatures of all the inventors or assignees of record of the entire interest or their representative(s) are required. Submit multiple forms if more than one signature is required, see below\*.

\* Total of \_\_\_\_\_ forms are submitted.

This collection of information is required by 37 CFR 1.363. The information is required to obtain or retain a benefit by the public which is to file (and by the USPTO to process) an application. Confidentiality is governed by 35 U.S.C. 122 and 37 CFR 1.11 and 1.14. This collection is estimated to take 5 minutes to complete, including gathering, preparing, and submitting the completed application form to the USPTO. Time will vary depending upon the individual case. Any comments on the amount of time you require to complete this form and/or suggestions for reducing this burden, should be sent to the Chief Information Officer, U.S. Patent and Trademark Office, U.S. Department of Commerce, P.O. Box 1450, Alexandria, VA 22313-1450. DO NOT SEND COMPLETE D FORMS TO THIS ADDRESS. SEND TO: Mail Stop M Correspondence, Commissioner for Patents, P.O. Box 1450, Alexandria, VA 22313-1450.

*If you need assistance in completing the form, call 1-800-PTO-9199 and select option 2.*



## Privacy Act Statement

The **Privacy Act of 1974 (P.L. 93-579)** requires that you be given certain information in connection with your submission of the attached form related to a patent application or patent. Accordingly, pursuant to the requirements of the Act, please be advised that: (1) the general authority for the collection of this information is 35 U.S.C. 2(b)(2); (2) furnishing of the information solicited is voluntary; and (3) the principal purpose for which the information is used by the U.S. Patent and Trademark Office is to process and/or examine your submission related to a patent application or patent. If you do not furnish the requested information, the U.S. Patent and Trademark Office may not be able to process and/or examine your submission, which may result in termination of proceedings or abandonment of the application or expiration of the patent.

The information provided by you in this form will be subject to the following routine uses:

1. The information on this form will be treated confidentially to the extent allowed under the Freedom of Information Act (5 U.S.C. 552) and the Privacy Act (5 U.S.C. 552a). Records from this system of records may be disclosed to the Department of Justice to determine whether disclosure of these records is required by the Freedom of Information Act.
2. A record from this system of records may be disclosed, as a routine use, in the course of presenting evidence to a court, magistrate, or administrative tribunal, including disclosures to opposing counsel in the course of settlement negotiations.
3. A record in this system of records may be disclosed, as a routine use, to a Member of Congress submitting a request involving an individual, to whom the record pertains, when the individual has requested assistance from the Member with respect to the subject matter of the record.
4. A record in this system of records may be disclosed, as a routine use, to a contractor of the Agency having need for the information in order to perform a contract. Recipients of information shall be required to comply with the requirements of the Privacy Act of 1974, as amended, pursuant to 5 U.S.C. 552a(m).
5. A record related to an International Application filed under the Patent Cooperation Treaty in this system of records may be disclosed, as a routine use, to the International Bureau of the World Intellectual Property Organization, pursuant to the Patent Cooperation Treaty.
6. A record in this system of records may be disclosed, as a routine use, to another federal agency for purposes of National Security review (35 U.S.C. 181) and for review pursuant to the Atomic Energy Act (42 U.S.C. 218(c)).
7. A record from this system of records may be disclosed, as a routine use, to the Administrator, General Services, or his/her designee, during an inspection of records conducted by GSA as part of that agency's responsibility to recommend improvements in records management practices and programs, under authority of 44 U.S.C. 2904 and 2906. Such disclosure shall be made in accordance with the GSA regulations governing inspection of records for this purpose, and any other relevant (*i.e.*, GSA or Commerce) directive. Such disclosure shall not be used to make determinations about individuals.
8. A record from this system of records may be disclosed, as a routine use, to the public after either publication of the application pursuant to 35 U.S.C. 122(b) or issuance of a patent pursuant to 35 U.S.C. 151. Further, a record may be disclosed, subject to the limitations of 37 CFR 1.14, as a routine use, to the public if the record was filed in an application which became abandoned or in which the proceedings were terminated and which application is referenced by either a published application, an application open to public inspection or an issued patent.
9. A record from this system of records may be disclosed, as a routine use, to a Federal, State, or local law enforcement agency, if the USPTO becomes aware of a violation or potential violation of law or regulation.

## Electronic Acknowledgement Receipt

<b>EFS ID:</b>	19073488
<b>Application Number:</b>	12209136
<b>International Application Number:</b>	
<b>Confirmation Number:</b>	3897
<b>Title of Invention:</b>	METHOD FOR TRANSMITTING UPLINK SIGNALS
<b>First Named Inventor/Applicant Name:</b>	Dae Won Lee
<b>Customer Number:</b>	23117
<b>Filer:</b>	John R. Lastova/Margaret Grey
<b>Filer Authorized By:</b>	John R. Lastova
<b>Attorney Docket Number:</b>	2101-3573
<b>Receipt Date:</b>	20-MAY-2014
<b>Filing Date:</b>	11-SEP-2008
<b>Time Stamp:</b>	09:53:14
<b>Application Type:</b>	Utility under 35 USC 111(a)

### Payment information:

Submitted with Payment	no
------------------------	----

### File Listing:

Document Number	Document Description	File Name	File Size(Bytes)/ Message Digest	Multi Part /.zip	Pages (if appl.)
1	Maintenance Fee Address Change	833-sb0047.pdf	203891 b2e6207eb23af2dee4ada5e02da6a424eed 83320	no	2

### Warnings:

### Information:

**This Acknowledgement Receipt evidences receipt on the noted date by the USPTO of the indicated documents, characterized by the applicant, and including page counts, where applicable. It serves as evidence of receipt similar to a Post Card, as described in MPEP 503.**

**New Applications Under 35 U.S.C. 111**

**If a new application is being filed and the application includes the necessary components for a filing date (see 37 CFR 1.53(b)-(d) and MPEP 506), a Filing Receipt (37 CFR 1.54) will be issued in due course and the date shown on this Acknowledgement Receipt will establish the filing date of the application.**

**National Stage of an International Application under 35 U.S.C. 371**

**If a timely submission to enter the national stage of an international application is compliant with the conditions of 35 U.S.C. 371 and other applicable requirements a Form PCT/DO/EO/903 indicating acceptance of the application as a national stage submission under 35 U.S.C. 371 will be issued in addition to the Filing Receipt, in due course.**

**New International Application Filed with the USPTO as a Receiving Office**

**If a new international application is being filed and the international application includes the necessary components for an international filing date (see PCT Article 11 and MPEP 1810), a Notification of the International Application Number and of the International Filing Date (Form PCT/RO/105) will be issued in due course, subject to prescriptions concerning national security, and the date shown on this Acknowledgement Receipt will establish the international filing date of the application.**

PTO/SB/80 (11-06)

Approved for use through 11/30/2011. OMB 0051-0036  
U.S. Patent and Trademark Office; U.S. DEPARTMENT OF COMMERCE

Under the Paperwork Reduction Act of 1996, no persons are required to respond to a collection of information unless it displays a valid OMB control number.

**POWER OF ATTORNEY TO PROSECUTE APPLICATIONS BEFORE THE USPTO**

I hereby revoke all previous powers of attorney given in the application identified in the attached statement under 37 CFR 3.73(b).

I hereby appoint:

Practitioners associated with the Customer Number:

23117

OR

Practitioner(s) named below (if more than ten patent practitioners are to be named, then a customer number must be used):

Name	Registration Number	Name	Registration Number

as attorney(s) or agent(s) to represent the undersigned before the United States Patent and Trademark Office (USPTO) in connection with any and all patent applications assigned only to the undersigned according to the USPTO assignment records or assignment documents attached to this form in accordance with 37 CFR 3.73(b).

Please change the correspondence address for the application identified in the attached statement under 37 CFR 3.73(b) to:

The address associated with Customer Number:

23117

OR

<input type="checkbox"/> Firm or Individual Name			
Address			
City	State	Zip	
Country			
Telephone	Email		

Assignee Name and Address:  
Optis Cellular Technology, LLC  
P.O. Box 250649  
Plano, Texas 75025

A copy of this form, together with a statement under 37 CFR 3.73(b) (Form PTO/SB/98 or equivalent) is required to be filed in each application in which this form is used. The statement under 37 CFR 3.73(b) may be completed by one of the practitioners appointed in this form if the appointed practitioner is authorized to act on behalf of the assignee, and must identify the application in which this Power of Attorney is to be filed.

**SIGNATURE of Assignee of Record**

The individual whose signature and title is supplied below is authorized to act on behalf of the assignee

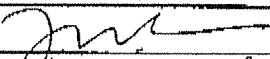
Signature		Date
Name	James W. Ribman	Telephone
Title	President	

This collection of information is required by 37 CFR 1.31, 1.32 and 1.33. The information is required to obtain or retain a benefit by the public which is to file (and by the USPTO to process) an application. Confidentiality is governed by 35 U.S.C. 122 and 37 CFR 1.11 and 1.14. This collection is estimated to take 3 minutes to complete, including gathering, preparing, and submitting the completed application form to the USPTO. Time will vary depending upon the individual case. Any comments on the amount of time you require to complete this form and/or suggestions for reducing this burden, should be sent to the Chief Information Officer, U.S. Patent and Trademark Office, U.S. Department of Commerce, P.O. Box 1450, Alexandria, VA 22313-1450. DO NOT SEND FEES OR COMPLETED FORMS TO THIS ADDRESS. SEND TO: Commissioner for Patents, P.O. Box 1450, Alexandria, VA 22313-1450.

If you need assistance in completing the form, call 1-800-PTO-9199 and select option 2.

Under the Paperwork Reduction Act of 1995, no persons are required to respond to a collection of information unless it displays a valid OMB control number.

**STATEMENT UNDER 37 CFR 3.73(b)**

Applicant/Patent Owner: LEE et al.

Application No./Patent No.: 8102833 Filed/Issue Date: 20120124

Titled: Method for transmitting uplink signals

OPTIS CELLULAR TECHNOLOGY, LLC, a corporation  
(Name of Assignee) (Type of Assignee, e.g., corporation, partnership, university, government agency, etc.)

states that it is:

- 1.  the assignee of the entire right, title, and interest in;
  - 2.  an assignee of less than the entire right, title, and interest in  
(The extent (by percentage) of its ownership interest is \_\_\_\_\_ %); or
  - 3.  the assignee of an undivided interest in the entirety of (a complete assignment from one of the joint inventors was made)
- the patent application/patent identified above, by virtue of either:

A.  An assignment from the inventor(s) of the patent application/patent identified above. The assignment was recorded in the United States Patent and Trademark Office at Reel \_\_\_\_\_, Frame \_\_\_\_\_, or for which a copy therefore is attached.

**OR**

B.  A chain of title from the inventor(s), of the patent application/patent identified above, to the current assignee as follows:

1. From: LEE et al. To: LG ELECTRONICS INC

The document was recorded in the United States Patent and Trademark Office at  
Reel 022044, Frame 0988, or for which a copy thereof is attached.

2. From: LG ELECTRONICS INC To: OPTIS CELLULAR TECHNOLOGY, LLC

The document was recorded in the United States Patent and Trademark Office at  
Reel 032326, Frame 0618, or for which a copy thereof is attached.

3. From: \_\_\_\_\_ To: \_\_\_\_\_

The document was recorded in the United States Patent and Trademark Office at  
Reel \_\_\_\_\_, Frame \_\_\_\_\_, or for which a copy thereof is attached.

Additional documents in the chain of title are listed on a supplemental sheet(s).

As required by 37 CFR 3.73(b)(1)(i), the documentary evidence of the chain of title from the original owner to the assignee was, or concurrently is being, submitted for recordation pursuant to 37 CFR 3.11.

[NOTE: A separate copy (i.e., a true copy of the original assignment document(s)) must be submitted to Assignment Division in accordance with 37 CFR Part 3, to record the assignment in the records of the USPTO. See MPEP 302.08]

The undersigned (whose title is supplied below) is authorized to act on behalf of the assignee.

/John R. Lastova/  
Signature

May 13, 2014  
Date

John R. Lastova  
Printed or Typed Name

Attorney  
Title

This collection of information is required by 37 CFR 3.73(b). The information is required to obtain or retain a benefit by the public which is to file (and by the USPTO to process) an application. Confidentiality is governed by 35 U.S.C. 122 and 37 CFR 1.11 and 1.14. This collection is estimated to take 12 minutes to complete, including gathering, preparing, and submitting the completed application form to the USPTO. Time will vary depending upon the individual case. Any comments on the amount of time you require to complete this form and/or suggestions for reducing this burden, should be sent to the Chief Information Officer, U.S. Patent and Trademark Office, U.S. Department of Commerce, P.O. Box 1450, Alexandria, VA 22313-1450. DO NOT SEND FEES OR COMPLETED FORMS TO THIS ADDRESS. **SEND TO: Commissioner for Patents, P.O. Box 1450, Alexandria, VA 22313-1450.**

## Privacy Act Statement

The **Privacy Act of 1974 (P.L. 93-579)** requires that you be given certain information in connection with your submission of the attached form related to a patent application or patent. Accordingly, pursuant to the requirements of the Act, please be advised that: (1) the general authority for the collection of this information is 35 U.S.C. 2(b)(2); (2) furnishing of the information solicited is voluntary; and (3) the principal purpose for which the information is used by the U.S. Patent and Trademark Office is to process and/or examine your submission related to a patent application or patent. If you do not furnish the requested information, the U.S. Patent and Trademark Office may not be able to process and/or examine your submission, which may result in termination of proceedings or abandonment of the application or expiration of the patent.

The information provided by you in this form will be subject to the following routine uses:

1. The information on this form will be treated confidentially to the extent allowed under the Freedom of Information Act (5 U.S.C. 552) and the Privacy Act (5 U.S.C. 552a). Records from this system of records may be disclosed to the Department of Justice to determine whether disclosure of these records is required by the Freedom of Information Act.
2. A record from this system of records may be disclosed, as a routine use, in the course of presenting evidence to a court, magistrate, or administrative tribunal, including disclosures to opposing counsel in the course of settlement negotiations.
3. A record in this system of records may be disclosed, as a routine use, to a Member of Congress submitting a request involving an individual, to whom the record pertains, when the individual has requested assistance from the Member with respect to the subject matter of the record.
4. A record in this system of records may be disclosed, as a routine use, to a contractor of the Agency having need for the information in order to perform a contract. Recipients of information shall be required to comply with the requirements of the Privacy Act of 1974, as amended, pursuant to 5 U.S.C. 552a(m).
5. A record related to an International Application filed under the Patent Cooperation Treaty in this system of records may be disclosed, as a routine use, to the International Bureau of the World Intellectual Property Organization, pursuant to the Patent Cooperation Treaty.
6. A record in this system of records may be disclosed, as a routine use, to another federal agency for purposes of National Security review (35 U.S.C. 181) and for review pursuant to the Atomic Energy Act (42 U.S.C. 218(c)).
7. A record from this system of records may be disclosed, as a routine use, to the Administrator, General Services, or his/her designee, during an inspection of records conducted by GSA as part of that agency's responsibility to recommend improvements in records management practices and programs, under authority of 44 U.S.C. 2904 and 2906. Such disclosure shall be made in accordance with the GSA regulations governing inspection of records for this purpose, and any other relevant (*i.e.*, GSA or Commerce) directive. Such disclosure shall not be used to make determinations about individuals.
8. A record from this system of records may be disclosed, as a routine use, to the public after either publication of the application pursuant to 35 U.S.C. 122(b) or issuance of a patent pursuant to 35 U.S.C. 151. Further, a record may be disclosed, subject to the limitations of 37 CFR 1.14, as a routine use, to the public if the record was filed in an application which became abandoned or in which the proceedings were terminated and which application is referenced by either a published application, an application open to public inspection or an issued patent.
9. A record from this system of records may be disclosed, as a routine use, to a Federal, State, or local law enforcement agency, if the USPTO becomes aware of a violation or potential violation of law or regulation.

<b>Change of CORRESPONDENCE ADDRESS Patent</b>  Address to: Mail Stop Post Issue Commissioner for Patents P.O. Box 1450 Alexandria, VA 22313-1450	Patent Number	8102833
	Issue Date	20120124
	Application No.	12/209136
	Filing Date	2008/09/11
	First Named Inventor	Dae Won LEE
Attorney Docket Number	- -	

Please change the Correspondence Address for the above-identified patent to:



The address associated with Customer Number:

23117

**OR**

Firm or Individual Name

Address

City

State

Zip

Country

Telephone

Email

This form cannot be used to change the data association with a Customer Number. To change the data associated with an existing Customer Number use "Request for Customer Number Data Change" (PTO/SB/124).

This form will not affect any "fee address" provided for the above-identified patent. To change a "fee address" use the "Fee Address Indication Form" (PTO/SB/47).

I am the:



Patentee

 Assignee of record of the entire interest. See 37 C.F.R. § 3.71.  
 Statement under 37 C.F.R. § 3.73(b) is enclosed. (Form PTO/SB/96)/

 Attorney or agent of record. Registration Number 33,149

Signature

/John R. Lastova/

Typed or  
Printed Name

John R. Lastova

Date

May 13, 2014

Telephone

703-816-4000

NOTE: Signatures of all the inventors or assignees of record of the entire interest or their representative(s) are required. Submit multiple forms if more than one signature is required, see below.\*

\*Total of 1 forms are submitted.

This collection of information is required by 37 C.F.R. § 1.33. The information is required to obtain or retain a benefit by the public which is to file (and by the USPTO to process) an application. Confidentiality is governed by 35 U.S.C. 122 and 37 C.F.R. § 1.11 and 1.14. This collection is estimated to take 3 minutes to complete, including gathering, preparing, and submitting the completed application form to the USPTO. Time will vary depending upon the individual case. Any comments on the amount of time you require to complete this form and/or suggestions for reducing this burden, should be sent to the Chief Information Officer, U.S. Patent and Trademark Office, U.S. Department of Commerce, P.O. Box 1450, Alexandria, VA 22313-1450. DO NOT SEND FEES OR COMPLETED FORMS TO THIS ADDRESS: **SEND TO: Mail Stop Post Issue, Commissioner for Patents, P.O. Box 1450, Alexandria, VA 22313-1450.**

If you need assistance in completing this form, call 1-800-PTO-9199 and select option 2.

## Electronic Acknowledgement Receipt

<b>EFS ID:</b>	19013180
<b>Application Number:</b>	12209136
<b>International Application Number:</b>	
<b>Confirmation Number:</b>	3897
<b>Title of Invention:</b>	METHOD FOR TRANSMITTING UPLINK SIGNALS
<b>First Named Inventor/Applicant Name:</b>	Dae Won Lee
<b>Customer Number:</b>	35884
<b>Filer:</b>	John R. Lastova/Margaret Grey
<b>Filer Authorized By:</b>	John R. Lastova
<b>Attorney Docket Number:</b>	2101-3573
<b>Receipt Date:</b>	13-MAY-2014
<b>Filing Date:</b>	11-SEP-2008
<b>Time Stamp:</b>	09:46:53
<b>Application Type:</b>	Utility under 35 USC 111(a)

### Payment information:

Submitted with Payment	no
------------------------	----

### File Listing:

Document Number	Document Description	File Name	File Size(Bytes)/ Message Digest	Multi Part /.zip	Pages (if appl.)
1	Power of Attorney	OPPOA.pdf	128381 <small>fbad5ea75b7ef1bedd30169e4c8f5c858837dd70</small>	no	1

### Warnings:

### Information:



2	Assignee showing of ownership per 37 CFR 3.73.	833-sb0096.pdf	426833 c4f0affc09b791e83a56cde471e9e964d2739ea7	no	2
<b>Warnings:</b>					
<b>Information:</b>					
3	Change of Address	833-CHG.pdf	21796 cdf08b450d7ca08ebf0c3f09645176d32ed380e9	no	1
<b>Warnings:</b>					
<b>Information:</b>					
<b>Total Files Size (in bytes):</b>			577010		
<p><b>This Acknowledgement Receipt evidences receipt on the noted date by the USPTO of the indicated documents, characterized by the applicant, and including page counts, where applicable. It serves as evidence of receipt similar to a Post Card, as described in MPEP 503.</b></p> <p><b><u>New Applications Under 35 U.S.C. 111</u></b>  <b>If a new application is being filed and the application includes the necessary components for a filing date (see 37 CFR 1.53(b)-(d) and MPEP 506), a Filing Receipt (37 CFR 1.54) will be issued in due course and the date shown on this Acknowledgement Receipt will establish the filing date of the application.</b></p> <p><b><u>National Stage of an International Application under 35 U.S.C. 371</u></b>  <b>If a timely submission to enter the national stage of an international application is compliant with the conditions of 35 U.S.C. 371 and other applicable requirements a Form PCT/DO/EO/903 indicating acceptance of the application as a national stage submission under 35 U.S.C. 371 will be issued in addition to the Filing Receipt, in due course.</b></p> <p><b><u>New International Application Filed with the USPTO as a Receiving Office</u></b>  <b>If a new international application is being filed and the international application includes the necessary components for an international filing date (see PCT Article 11 and MPEP 1810), a Notification of the International Application Number and of the International Filing Date (Form PCT/RO/105) will be issued in due course, subject to prescriptions concerning national security, and the date shown on this Acknowledgement Receipt will establish the international filing date of the application.</b></p>					

## PATENT ASSIGNMENT COVER SHEET

Electronic Version v1.1  
 Stylesheet Version v1.2

EPAS ID: PAT2716420

SUBMISSION TYPE:	NEW ASSIGNMENT
NATURE OF CONVEYANCE:	SECURITY AGREEMENT
CONVEYING PARTY DATA	
Name	Execution Date
OPTIS CELLULAR TECHNOLOGY, LLC	12/19/2013

RECEIVING PARTY DATA	
Name:	WILMINGTON TRUST, NATIONAL ASSOCIATION (AS COLLATERAL AGENT)
Street Address:	50 SOUTH SIXTH STREET, SUITE 1290
City:	MINNEAPOLIS
State/Country:	MINNESOTA
Postal Code:	55402

PROPERTY NUMBERS Total: 392	
Property Type	Number
Application Number:	08623507
Application Number:	08994956
Application Number:	08921321
Application Number:	09251018
Application Number:	09471603
Application Number:	09196127
Application Number:	10780783
Application Number:	09140470
Application Number:	09340254
Application Number:	09713505
Application Number:	09572846
Application Number:	09703037
Application Number:	09746823
Application Number:	11551937
Application Number:	09894297

Application Number:	09859237
Application Number:	10259435
Application Number:	13874809
Application Number:	12664962
Application Number:	12866534
Application Number:	08668815
Application Number:	08697742
Application Number:	08708034
Application Number:	08709251
Application Number:	08717462
Application Number:	08746339
Application Number:	08749236
Application Number:	08941241
Application Number:	08722680
Application Number:	08759182
Application Number:	08990371
Application Number:	08747463
Application Number:	08747846
Application Number:	08752020
Application Number:	08781940
Application Number:	08766181
Application Number:	08777625
Application Number:	08797404
Application Number:	08798137
Application Number:	08804107
Application Number:	08808845
Application Number:	08802047
Application Number:	08823027
Application Number:	08834287
Application Number:	08902051
Application Number:	08920596
Application Number:	08917578
Application Number:	08928195
Application Number:	08923675
Application Number:	08933111

	08936507
Application Number:	09163820
Application Number:	08888215
Application Number:	08986329
Application Number:	09220264
Application Number:	13292738
Application Number:	11538535
Application Number:	12447396
Application Number:	12663459
Application Number:	12187553
Application Number:	12893383
Application Number:	08764991
Application Number:	08773661
Application Number:	08773438
Application Number:	09005367
Application Number:	09023428
Application Number:	09057367
Application Number:	09066953
Application Number:	09073267
Application Number:	09072332
Application Number:	09443362
Application Number:	09089517
Application Number:	09073438
Application Number:	09099323
Application Number:	09104328
Application Number:	09161231
Application Number:	08957244
Application Number:	09196166
Application Number:	09686637
Application Number:	08958842
Application Number:	09001870
Application Number:	09217226
Application Number:	09383915
Application Number:	09333882
Application Number:	09044357

	09045753
Application Number:	09383732
Application Number:	09300127
Application Number:	09306144
Application Number:	09080074
Application Number:	09120203
Application Number:	09094140
Application Number:	09310171
Application Number:	09083012
Application Number:	09411986
Application Number:	09131336
Application Number:	09128755
Application Number:	09167758
Application Number:	09862848
Application Number:	09305956
Application Number:	09224344
Application Number:	09217048
Application Number:	09217049
Application Number:	09548161
Application Number:	09248887
Application Number:	09240409
Application Number:	09778494
Application Number:	09283684
Application Number:	09248434
Application Number:	09309017
Application Number:	09313044
Application Number:	09372015
Application Number:	09337448
Application Number:	09359729
Application Number:	09359250
Application Number:	09500517
Application Number:	10359974
Application Number:	09405372
Application Number:	09387088
Application Number:	09408069

	09228878
Application Number:	09444831
Application Number:	09594769
Application Number:	09283652
Application Number:	09588599
Application Number:	09252028
Application Number:	09461029
Application Number:	09454224
Application Number:	09522399
Application Number:	09885520
Application Number:	10019692
Application Number:	09736321
Application Number:	09621392
Application Number:	09499976
Application Number:	09512493
Application Number:	09474950
Application Number:	09631474
Application Number:	09401573
Application Number:	09658103
Application Number:	09472881
Application Number:	09374265
Application Number:	09717001
Application Number:	09657999
Application Number:	09887144
Application Number:	09748185
Application Number:	09749920
Application Number:	09585514
Application Number:	09698600
Application Number:	09866241
Application Number:	09931546
Application Number:	10000803
Application Number:	09835479
Application Number:	09985634
Application Number:	10311588
Application Number:	09609635

	10036665
Application Number:	09708526
Application Number:	09998921
Application Number:	09973805
Application Number:	10479292
Application Number:	10750900
Application Number:	10112046
Application Number:	10112035
Application Number:	11229622
Application Number:	10704146
Application Number:	10471825
Application Number:	10475137
Application Number:	10947409
Application Number:	09999651
Application Number:	10011669
Application Number:	09970369
Application Number:	10077318
Application Number:	10185746
Application Number:	10661883
Application Number:	10157221
Application Number:	10012348
Application Number:	10536253
Application Number:	10509828
Application Number:	10506035
Application Number:	11225851
Application Number:	11298748
Application Number:	10595426
Application Number:	10597811
Application Number:	11662386
Application Number:	10581786
Application Number:	10584907
Application Number:	10580611
Application Number:	10581788
Application Number:	10596615
Application Number:	10586139

	11573312
Application Number:	10857359
Application Number:	11576230
Application Number:	11720497
Application Number:	11915072
Application Number:	11813127
Application Number:	11916583
Application Number:	11914657
Application Number:	11995396
Application Number:	12090710
Application Number:	11915706
Application Number:	12088972
Application Number:	11921179
Application Number:	12097863
Application Number:	12090129
Application Number:	12064965
Application Number:	12278379
Application Number:	12094310
Application Number:	12373541
Application Number:	12447804
Application Number:	12527535
Application Number:	12520709
Application Number:	11733333
Application Number:	13158936
Application Number:	12447844
Application Number:	12441484
Application Number:	11684692
Application Number:	12598817
Application Number:	12665183
Application Number:	12522624
Application Number:	12666203
Application Number:	12522794
Application Number:	12522785
Application Number:	12665627
Application Number:	12679932



	12674335
Application Number:	12739012
Application Number:	12676005
Application Number:	12992692
Application Number:	12667829
Application Number:	12674020
Application Number:	12991479
Application Number:	12105650
Application Number:	12920890
Application Number:	13956136
Application Number:	12234067
Application Number:	13281291
Application Number:	12993153
Application Number:	13062743
Application Number:	12997957
Application Number:	13061969
Application Number:	13128776
Application Number:	12342439
Application Number:	13126027
Application Number:	13130445
Application Number:	13061218
Application Number:	13127188
Application Number:	12993555
Application Number:	12990880
Application Number:	14056512
Application Number:	12507376
Application Number:	13130854
Application Number:	13263255
Application Number:	13140691
Application Number:	13142509
Application Number:	13144947
Application Number:	13129149
Application Number:	13319171
Application Number:	13264573
Application Number:	13320802

	13144327
Application Number:	13145232
Application Number:	13148433
Application Number:	13393704
Application Number:	13391863
Application Number:	13378263
Application Number:	12758744
Application Number:	13509826
Application Number:	13516504
Application Number:	13394219
Application Number:	12639032
Application Number:	12650201
Application Number:	13580840
Application Number:	13505160
Application Number:	13580999
Application Number:	13699105
Application Number:	12972460
Application Number:	13124747
Application Number:	13575168
Application Number:	13049186
Application Number:	13075254
Application Number:	13824746
Application Number:	13144784
Application Number:	13144766
Application Number:	13050210
Application Number:	13981700
Application Number:	14005210
Application Number:	13099518
Application Number:	13043027
Application Number:	13992348
Application Number:	14000371
Application Number:	14004403
Application Number:	14113959
Application Number:	13257605
Application Number:	14122645

	13155527
Application Number:	13155631
Application Number:	13178048
Application Number:	13271515
Application Number:	13228926
Application Number:	13381606
Application Number:	13765046
Application Number:	13816039
Application Number:	61705679
Application Number:	14035213
Application Number:	13722298
Application Number:	61707366
Application Number:	14039554
Application Number:	10451588
Application Number:	10502312
Application Number:	10597212
Application Number:	12090175
Application Number:	12349465
Application Number:	12759645
Application Number:	12868642
Application Number:	13409057
Application Number:	12457653
Application Number:	13071280
Application Number:	13894948
Application Number:	12678200
Application Number:	12724318
Application Number:	13109962
Application Number:	13109963
Application Number:	12205530
Application Number:	12913654
Application Number:	13312809
Application Number:	13312804
Application Number:	12523090
Application Number:	13051803
Application Number:	12209136

	13316315
Application Number:	13590048
Application Number:	12252270
Application Number:	12963570
Application Number:	12963588
Application Number:	13185343
Application Number:	13185362
Application Number:	12392654
Application Number:	12909780
Application Number:	12363522
Application Number:	12404873
Application Number:	12836403
Application Number:	13563472
Application Number:	13345532
Application Number:	13802066
Application Number:	10341356
Application Number:	10036377
Application Number:	11147350
Application Number:	12247567
Application Number:	11828978
Application Number:	10465724
Application Number:	11896419
Application Number:	12648248
Application Number:	11729807
Application Number:	12673262
Application Number:	12705215
Application Number:	10607551
Application Number:	10438032
Application Number:	11016308
Application Number:	10737212
Application Number:	11325934
Application Number:	11445825
Application Number:	11469063
Application Number:	09671115
Application Number:	10078674

	10125531
Application Number:	10192895
Application Number:	10630721
Application Number:	10775240
Application Number:	09974845
Application Number:	11735377
Application Number:	09078578
Application Number:	09273765
Application Number:	09224053
Application Number:	09671208
Application Number:	11459223
Application Number:	11538424
Application Number:	10659386
Application Number:	11322280
Application Number:	11364410
Application Number:	11441139
Application Number:	11864752
Application Number:	12176314
Application Number:	12111004
Application Number:	12506486
Application Number:	12423769
Application Number:	10902801
Application Number:	09737283
Application Number:	11682957
Application Number:	11549629
Application Number:	13353270
PCT Number:	EP2012060245

## CORRESPONDENCE DATA

Fax Number:

Email: smckinney@paulweiss.com, dewilliams@paulweiss.com

*Correspondence will be sent via US Mail when the email attempt is unsuccessful.*

Correspondent Name: SCOTT A. MCKINNEY

Address Line 1: 1285 AVENUE OF THE AMERICAS

Address Line 4: NEW YORK, NEW YORK 10019-6064

ATTORNEY DOCKET NUMBER:

18693-027

SCOTT MCKINNEY

Signature:

/Scott McKinney/

Date:

02/06/2014

This document serves as an Oath/Declaration (37 CFR 1.63).

**Total Attachments: 34**

source=2nd Lien patents Security Agreement#page1.tif  
source=2nd Lien patents Security Agreement#page2.tif  
source=2nd Lien patents Security Agreement#page3.tif  
source=2nd Lien patents Security Agreement#page4.tif  
source=2nd Lien patents Security Agreement#page5.tif  
source=2nd Lien patents Security Agreement#page6.tif  
source=2nd Lien patents Security Agreement#page7.tif  
source=2nd Lien patents Security Agreement#page8.tif  
source=2nd Lien patents Security Agreement#page9.tif  
source=2nd Lien patents Security Agreement#page10.tif  
source=2nd Lien patents Security Agreement#page11.tif  
source=2nd Lien patents Security Agreement#page12.tif  
source=2nd Lien patents Security Agreement#page13.tif  
source=2nd Lien patents Security Agreement#page14.tif  
source=2nd Lien patents Security Agreement#page15.tif  
source=2nd Lien patents Security Agreement#page16.tif  
source=2nd Lien patents Security Agreement#page17.tif  
source=2nd Lien patents Security Agreement#page18.tif  
source=2nd Lien patents Security Agreement#page19.tif  
source=2nd Lien patents Security Agreement#page20.tif  
source=2nd Lien patents Security Agreement#page21.tif  
source=2nd Lien patents Security Agreement#page22.tif  
source=2nd Lien patents Security Agreement#page23.tif  
source=2nd Lien patents Security Agreement#page24.tif  
source=2nd Lien patents Security Agreement#page25.tif  
source=2nd Lien patents Security Agreement#page26.tif  
source=2nd Lien patents Security Agreement#page27.tif  
source=2nd Lien patents Security Agreement#page28.tif  
source=2nd Lien patents Security Agreement#page29.tif  
source=2nd Lien patents Security Agreement#page30.tif  
source=2nd Lien patents Security Agreement#page31.tif  
source=2nd Lien patents Security Agreement#page32.tif  
source=2nd Lien patents Security Agreement#page33.tif  
source=2nd Lien patents Security Agreement#page34.tif

SHORT-FORM PATENTS SECURITY AGREEMENT

WHEREAS, Optis Cellular Technology, LLC, a Delaware limited liability company (the “Grantor”) has applied for letters patent and has been granted letters patents in the United States Patent and Trademark Office, and is the owner of the patent applications and patents listed in the attached Schedule of Patents and Patent Applications associated therewith;

WHEREAS, the Grantor has contemporaneously with the execution of this Short-Form Patents Security Agreement entered into the Pledge, Security and Guaranty Agreement dated as of December 19, 2013 (as modified from time to time, the “Security Agreement”), in which the Grantor has granted certain interests in favor of Wilmington Trust, National Association, as collateral agent (the “Collateral Agent”) for the benefit of the Secured Parties (as defined therein);

WHEREAS, pursuant to the Security Agreement, the Grantor has agreed with the Collateral Agent and the Secured Parties to execute this Short-Form Patents Security Agreement;

NOW, THEREFORE, for good and valuable consideration, the receipt and sufficiency of which are hereby acknowledged, the Grantor hereby grants to the Collateral Agent for the benefit of the Secured Parties, to the extent provided in the Security Agreement (the terms and conditions of which are hereby incorporated herein), a second lien security interest in all of its right, title and interest in, to and under all the patents and patent applications whether now owned or at any time hereafter acquired, of the Grantor issued by, or for which applications have been filed with, the United States Patent and Trademark Office, including the patents and applications on the attached Schedule of Patents and Patent Applications, and all related patents and applications thereto, including all reissuances, continuations, continuations-in-part, revisions, extensions, re-examinations thereof, any patents and patent applications claiming priority to said patents and patent applications or from which said patents and patent applications claim priority, and pending applications associated therewith, as collateral security for the prompt and complete payment and performance when due of all the Secured Obligations (as defined in the Security Agreement). Notwithstanding the foregoing, in the event of any conflict between this Short-Form Patents Security Agreement and the Security Agreement, the Security Agreement shall control.

Dated: December 19, 2013

[Signature Page to Follow]

OPTIS CELLULAR TECHNOLOGY, LLC

By:   
Name: Leslie D. Ware  
Title: President



SCHEDULE OF  
PATENTS AND PATENT APPLICATIONS

**Patents of Grantor**

Ref No.	Country	Status	Title	App No.	App Date	Patent No.	Patent Date
P06900 FAM	US	GRANTED	Remotely Retrieving SIM Stored Data Over a Connection-less Communications Link	08/623507	1996-03-28	5915225	1999-06-22
P07649 FAM	US	GRANTED	A mobile communication unit	08/994956	1997-12-19	6128381	2000-10-03
P08444 FAM	US	GRANTED	A method for selecting a combination of modulation and channel coding schemes in a digital communication system	08/921321	1997-08-29	6167031	2000-12-26
P09693 FAM	US	GRANTED	Power control in a CDMA mobile communications system	09/251018	1999-02-16	6463296	2002-10-08
P10039 FAM	US	GRANTED	Method for Determining Initial Charge on Battery	09/471603	1999-12-23	6236214	2001-05-22
P10059 FAM	US	GRANTED	Thermal Transmission Control of Wireless Data Modem	09/196127	1998-11-20	6760311	2004-07-06
P10059 FAM	US	GRANTED	Thermal Transmission Control of Wireless Data Modem	10/780783	1998-11-20	7860018	2010-12-28

Ref No.	Country	Status	Title	App No.	App Date	Patent No.	Patent Date
P10830 FAM	US	GRANTED	Control of power ratios for in-phase and quadrature channels in a communications system	09/140470	1998-08-26	6337876	2002-01-08
P10932 FAM	US	GRANTED	Synchronization and detection of modulation type	09/340254	1999-07-01	6463107	2002-10-08
P11745 FAM	US	GRANTED	Battery Savings for Advanced Features	09/713505	2000-11-15	6697953	2004-02-24
P11919 FAM	US	GRANTED	Method and apparatus for broadcasting system information in a cellular communications network	09/572846	2000-05-18	6628946	2003-09-30
P12470 FAM	US	GRANTED	IQ Modulation Systems and Methods That Use Separate Phase and Amplitude Signal Paths	09/703037	2000-10-31	6975686	2005-12-13
P12470 FAM	US	GRANTED	IQ Modulation Systems and Methods That Use Separate Phase and Amplitude Signal Paths	09/746823	2000-12-22	7072421	2006-07-04
P13611 FAM	US	FILED	Method and device for improving the transmission efficiency in a communication system with a layered protocol stack	11/551937	2001-06-28		
P13611 FAM	US	GRANTED	Method and device for improving the transmission efficiency in a communication system with a layered protocol stack	09/894297	2001-06-28	7145897	2006-12-05

Ref No.	Country	Status	Title	App No.	App Date	Patent No.	Patent Date
P13955 FAM	US	GRANTED	Battery capacity calibration	09/859237	2001-05-16	6630814	2003-10-07
P16070 FAM	US	GRANTED	SECURITY RECONFIGURATION IN A UNIVERSAL MOBILE TELECOMMUNICATIONS SYSTEM	10/259435	2002-09-30	7020455	2006-03-28
P24251 FAM	US	FILED	METHODS AND SYSTEMS FOR SCHEDULING RESOURCES IN A TELECOMMUNICATION SYSTEM	13/874809	2013-05-01		
P24251 FAM	US	GRANTED	METHODS AND SYSTEMS FOR SCHEDULING RESOURCES IN A TELECOMMUNICATION SYSTEM	12/664962	2007-12-19	8437293	2013-05-07
P25674 FAM	US	FILED	METHOD AND ARRANGEMENT IN A TELECOMMUNICATION SYSTEM	12/866534	2008-09-18		
P07121 FAM	US	GRANTED	A Relaxation Oscillator of Reduced Complexity Using CMOS Equivalent of a Four-Layer Diode	08/668815	1996-06-24	5654677	1997-08-05
P07293 FAM	US	GRANTED	Up Converted Home Base Station	08/697742	1996-08-29	5930728	1999-07-27
P07298 FAM	US	GRANTED	Mobile-Assisted Handover Between a Private Radio Comm's. Network and Public Mobile Network	08/708034	1996-08-30	6112088	2000-08-29

Ref No.	Country	Status	Title	App No.	App Date	Patent No.	Patent Date
P07304 FAM	US	GRANTED	Telephone Having Sealed Acoustical Passageway through Flip Cover Hinge	08/709251	1996-09-10	5915015	1996-09-10
P07315 FAM	US	GRANTED	Antenna Matching Network Switching Requiring No Switch Contacts	08/717462	1996-09-20	5874921	1999-02-23
P07426 FAM	US	GRANTED	System connector	08/746339	1996-11-08	6212402	2001-04-03
P07448 FAM	US	GRANTED	Method for Increasing Control Channel Capacity in a Communication System	08/749236	1996-11-15	5933418	1999-08-03
P07453 FAM	US	GRANTED	Receive Only Watch	08/941241	1997-09-30	6108534	2000-08-22
P07462 FAM	US	GRANTED	Flip On/Off Detector	08/722680	1996-09-30	5918188	1999-06-29
P07501 FAM	US	GRANTED	Local time manager	08/759182	1996-12-04	5818920	1998-10-06
P07510 FAM	US	GRANTED	Arrangement, system and method relating to telecommunications acces and control	08/990371	1997-12-15	6049712	2000-04-11

Ref No.	Country	Status	Title	App No.	App Date	Patent No.	Patent Date
P07533 FAM	US	GRANTED	Multi-Layered Interface for Interconnecting Application Programs to System Bus Lines for Electronic Devices	08/747463	1996-11-12	6651104	2003-11-18
P07534 FAM	US	GRANTED	Electroluminescent Backlit Devices	08/747846	1996-11-13	5971557	1999-10-26
P07540 FAM	US	GRANTED	Time-Multiplexed short message Acknowledgement systems and Methods	08/752020	1996-11-19	6606309	2003-08-12
P07558 FAM	US	GRANTED	Method for c in a Mobile Satellite Communication System	08/781940	1996-12-03	5956646	1999-09-21
P07604 FAM	US	GRANTED	Method and Apparatus for Initializing Semiconductor Memory	08/766181	1996-12-12	6229737	2001-05-08
P07645 FAM	US	GRANTED	SIM Card Containment Assembly	08/777625	1996-12-31	5883786	1999-03-16
P07774 FAM	US	GRANTED	Adaptive Frequency Reuse Plan	08/797404	1997-02-10	5974324	1999-10-26
P07776 FAM	US	GRANTED	Mobile Satellite Phone System Incorporating Symmetrical and Non-Symmetrical Waveform Modes	08/798137	1997-02-12	6650868	2003-11-18

Ref No.	Country	Status	Title	App No.	App Date	Patent No.	Patent Date
P07832 FAM	US	GRANTED	Support of multiple modulation levels for a cellular traffic channel	08/804107	1997-02-20	6061549	2000-05-09
P07836 FAM	US	GRANTED	Method and Apparatus for Assigning Personality Information to Roaming Mobile Radios	08/808845	1997-02-28	6002930	1999-12-14
P07854 FAM	US	GRANTED	Apparatus and associated method for adaptively selecting a paging area in which to page a mobile terminal	08/802047	1997-02-18	6058308	2000-05-02
P07898 FAM	US	GRANTED	Satellite Telecommunications Repeaters and Retransmission Methods	08/823027	1997-03-21	5937332	1999-08-10
P08018 FAM	US	GRANTED	Latch Mechanism for Mobile Communication Devices	08/834287	1997-04-15	5831579	1998-11-03
P08347 FAM	US	GRANTED	Method for Reducing Scan Time	08/902051	1997-07-29	6052590	2000-04-18
P08399 FAM	US	GRANTED	Fixed and Mobile Satellite Radiotelephone Systems and Methods with Capacity Sharing	08/920596	1997-08-29	6052586	2000-04-18
P08408 FAM	US	GRANTED	Method and apparatus for standby state cell selection in a cellular telephone system	08/917578	1997-08-22	6163694	2000-12-19

Ref No.	Country	Status	Title	App.No.	App Date	Patent No.	Patent Date
P08458 FAM	US	GRANTED	Frame Structure for Cellular Telephone	08/928195	1997-09-12	6058293	2000-05-02
P08470 FAM	US	GRANTED	System and Method for Self-Adaptive Maximum Likelihood Sequence Detection	08/923675	1997-09-04	6134277	2000-10-17
P08476 FAM	US	GRANTED	Circuit and Method for Using the I2C Serial Protocol with Multiple Voltages	08/933111	1997-09-18	6078192	2000-06-20
P08477 FAM	US	GRANTED	Methods and Systems for Communicating Information Using Separable Modulation Constellations	08/936507	1997-09-24	6078626	2000-06-20
P08482 FAM	US	GRANTED	Integrated means for communication	09/163820	1998-09-30	6470174	2002-10-22
P08594 FAM	US	GRANTED	Methods and Apparatus for Selectively Displaying Information Entered from a Radiotelephone Keypad	08/888215	1997-07-03	6208877	2001-03-27
P08774 FAM	US	GRANTED	Improved Audio in a Mobile Receiver	08/986329	1997-12-08	6317613	2001-11-13
P08851 FAM	US	GRANTED	A hand-held display device and a method of displaying screen images	09/220264	1998-12-23	6411275	2002-06-25

Ref No.	Country	Status	Title	App No.	App Date	Patent No.	Patent Date
P21295 FAM	US	FILED	Signaling Support for Antenna Selection Using Subset Lists and Subset Masks	13/292738	2011-11-09		
P21295 FAM	US	GRANTED	Signaling Support for Antenna Selection Using Subset Lists and Subset Masks	11/538535	2006-10-04	8068872	2011-11-29
P22906 FAM	US	FILED	LENGTH INDICATOR OPTIMIZATION	12/447396	2007-06-20		
P24242 FAM	US	GRANTED	DATA BLOCK SIZE MANAGEMENT IN A COMMUNICATION SYSTEM UTILIZING HYBRID AUTOMATIC REPEAT REQUESTS WITH SOFT COMBINING	12/663459	2008-05-09	8341484	2012-12-25
P26464 FAM	US	GRANTED	SYNCHRONIZATION DETECTION USING BANDWIDTH AND ANTENNA CONFIGURATION	12/187553	2008-08-07	7986758	2011-07-26
P30100 FAM	US	GRANTED	Methods and arrangements in a mobile telecommunication network	12/893383	2010-09-29	8447343	2013-05-21

Ref No.	Country	Status	Title	App No.	App Date	Patent No.	Patent Date
P07611 FAM	US	GRANTED	Multi-Sector Antennae Configuration	08/764991	1996-12-16	5936580	1999-08-10
P07630 FAM	US	GRANTED	Antenna System for Dual Mode Satellite/Cellular Portable	08/773661	1996-12-24	6025816	2000-02-15



Ref No.	Country	Status	Title	App No.	App Date	Patent No.	Patent Date
P07635 FAM	US	GRANTED	Apparatus for Enabling a Keypad in Response to Antenna Extension	08/773438	1996-12-27	5987311	1999-11-16
P07651 FAM	US	GRANTED	Device for antennas	09/005367	1998-01-09	6133877	2000-10-17
P07819 FAM	US	GRANTED	Compact dual polarized antenna element	09/023428	1998-02-13	6061032	2000-05-09
P07930 FAM	US	GRANTED	An antenna unit	09/057367	1998-04-08	5990839	1999-11-23
P07974 FAM	US	GRANTED	An apparatus and a method relating to antenna systems	09/066953	1998-04-28	6018320	2000-01-25
P08009 FAM	US	GRANTED	Radio-antenna arrangement with variable lobe width	09/073267	1998-05-06	6218987	2001-04-17
P08012 FAM	US	GRANTED	Method and device for beamport combining	09/072332	1998-05-04	6081233	2000-06-27
P08012 FAM	US	GRANTED	Method and device for beamport combining	09/443362	1998-05-04	6225947	2001-05-01
P08117 FAM	US	GRANTED	Device in antenna system	09/089517	1998-06-03	6100856	2000-08-08
P08121 FAM	US	GRANTED	Antenna device	09/073438	1998-05-06	6104347	2000-08-15
P08168 FAM	US	GRANTED	Balanced diversity	09/099323	1998-06-18	6574461	2003-06-03
P08208 FAM	US	GRANTED	Microstrip structure	09/104328	1998-06-25	5977915	1999-11-02
P08522 FAM	US	GRANTED	Zero-bias detector	09/161231	1998-09-28	6097247	2000-08-01
P08610 FAM	US	GRANTED	Terminal antenna for communications systems	08/957244	1997-10-24	6034634	2000-03-07
P08719 FAM	US	GRANTED	Suspended Double Microstrip	09/196166	1998-11-20	6150982	2000-11-21
P08720 FAM	US	GRANTED	Suspended Double Microstrip in PCB	09/686637	2000-10-11	6266016	2001-07-24
P08911 FAM	US	GRANTED	Multiple band telescope type antenna for mobile phone	08/958842	1997-10-28	6310578	2001-10-30
P08973 FAM	US	GRANTED	Retractable Radiotelephone Antennas with Extended Feeds	09/001870	1997-12-31	6097934	2000-08-01
P09014 FAM	US	GRANTED	Low voltage transistor biasing	09/217226	1998-12-21	6255885	2001-07-03
P09059 FAM	US	GRANTED		09/383915	1999-08-26	6369677	2002-04-09
P09227 FAM	US	GRANTED	Anordning och förfarande för skyddande av ett föremål	09/333882	1999-06-15	6389777	2002-05-21
P09230 FAM	US	GRANTED	Link-efficiency based scheduling in radio data communications systems	09/044357	1998-03-19	6236656	2001-05-22

Ref No.	Country	Status	Title	App No.	App Date	Patent No.	Patent Date
P09274 FAM	US	GRANTED	Radio Frequency Antenna	09/045753	1998-03-20	6204816	2001-03-20
P09291 FAM	US	GRANTED	Antenna arrangement	09/383732	1999-08-26	6239750	2001-05-29
P09357 FAM	US	GRANTED	Skapande av avsiktlig sidlob	09/300127	1999-04-27	6542519	2003-04-01
P09451 FAM	US	GRANTED	Impedance-matching device	09/306144	1999-05-06	6222500	2001-04-24
P09504 FAM	US	GRANTED	Flip Open Antenna for a Communication Device	09/080074	1998-05-15	5995052	1999-11-30
P09520 FAM	US	GRANTED		09/120203	1998-07-22	6334202	2001-12-25
P09532 FAM	US	GRANTED	Mobile Unit for Pilot Symbol Assisted Wireless System and Method of Improving Performance Thereof	09/094140	1998-06-09	6381290	2002-04-30
P09538 FAM	US	GRANTED	Metod för framställning av en antennstruktur och antennstruktur framställd medelst nämnda metod	09/310171	1999-05-12	6285335	2001-09-04
P09618 FAM	US	GRANTED	Apparatus and Method of Formatting a List for Display on a Touchscreen	09/083012	1998-05-21	6157379	2000-12-05
P09703 FAM	US	GRANTED	Improvement of polarization isolation in antennas	09/411986	1999-11-17	6225950	2001-05-01
P09749 FAM	US	GRANTED		09/131336	1998-08-07	6202074	2001-03-13
P09952 FAM	US	GRANTED	Antenna for Hand-Held Communication User Terminal	09/128755	1998-08-04	6107968	2000-08-22
P10029 FAM	US	GRANTED	Integral Antenna Assembly and Housing for Electronic Device	09/167758	1998-10-07	6107970	2000-08-22
P10094 FAM	US	GRANTED	Paging Antenna and Radiotelephones Incorporating Same	09/862848	2001-05-21	6430419	2002-08-06
P10094 FAM	US	GRANTED	Paging Antenna and Radiotelephones Incorporating Same	09/305956	1999-05-06	6259897	2001-07-10
P10102 FAM	US	GRANTED	Integrated Transmitter and Receiver Components for a Dual-Band Transceiver	09/224344	1998-12-31	6522895	2003-02-18
P10122 FAM	US	GRANTED	Flat Blade Antenna and Flip Mounting Structures	09/217048	1998-12-21	6232924	2001-05-15
P10134 FAM	US	GRANTED	Antenna Electrical Coupling Configurations	09/217049	1998-12-21	6249688	2001-06-19
P10224 FAM	US	GRANTED	Tunable microwave devices	09/548161	2000-04-13	6433375	2002-08-13

Ref.No.	Country	Status	Title	App No.	App Date	Patent No.	Patent Date
P10361 FAM	US	GRANTED	Systems & Methods for Coaxially Coupling an Antenna Through an Insulator	09/248887	1999-02-11	6215449	2001-04-10
P10390 FAM	US	GRANTED	Method Of Conformal Coating Internal Circuitry Of Assembled Equipment	09/240409	1999-01-29	6219258	2001-04-17
P10390 FAM	US	GRANTED	Method Of Conformal Coating Internal Circuitry Of Assembled Equipment	09/778494	2001-02-07	6629365	2003-10-07
P10394 FAM	US	GRANTED	An Adaptive Rate Channel Scanning Method For TDMA Wireless Communication Systems	09/283684	1999-04-01	6807163	2004-10-19
P10396 FAM	US	GRANTED	S&M for Coaxially Coupling an Antenna to a Radiotelephone through a Window & Amplifying Signals Adjacent and Inside the Window	09/248434	1999-02-11	6069588	2000-05-30
P10402 FAM	US	GRANTED	Mechanical Spring Antenna and Radiotelephones Incorporating Same	09/309017	1999-05-10	6272356	2001-08-07
P10429 FAM	US	GRANTED	Parasitic Dualband Matching Of An Internal Looped Dipole Antenna	09/313044	1999-05-17	6198943	2001-03-06
P10466 FAM	US	GRANTED	Apparatus and Methods for Extended Base Station Range Using Staggered Uplink Frame Structures	09/372015	1999-08-11	6633559	2003-10-14
P10474 FAM	US	GRANTED	Systems and Methods for Communicating Messages Among Cascaded Devices by Bit Shifting	09/337448	1999-06-21	6628676	2003-09-30
P10477 FAM	US	GRANTED	Methods for Forming Charge Coupled Devices Including Buried Transmissions Gates	09/359729	1999-07-22	6204826	2001-03-20
P10530 FAM	US	GRANTED	Multiple Frequency-band branch antenna	09/359250	1999-07-22	6198442	2001-03-06
P10548 FAM	US	GRANTED	Antenna Push Button Assembly and Portable Radiotelephone Including Same	09/500517	2000-02-09	6545642	2003-04-08
P10548 FAM	US	GRANTED	Antenna Push Button Assembly and Portable Radiotelephone Including Same	10/359974	2003-02-07	6812898	2004-11-02
P10656 FAM	US	GRANTED	External Driving Circuit for Bridge Type Synchronous Rectification	09/405372	1999-09-24	6111769	2000-08-29

Ref No.	Country	Status	Title	App No.	App Date	Patent No.	Patent Date
P10792 FAM	US	GRANTED	Mobile telephone apparatus and method for call divert service	09/387088	1999-08-31	6611682	2003-08-26
P10823 FAM	US	GRANTED	Method and arrangement for improving null depths	09/408069	1999-09-29	6236364	2001-05-22
P10850 FAM	US	GRANTED	Communications network and method for directly routing calls to mobile subscribers using an internet protocol network	09/228878	1999-01-12	6693894	2004-02-17
P10912 FAM	US	GRANTED		09/444831	1999-11-22	6215369	2001-04-10
P10972 FAM	US	GRANTED	Tunable spiral antenna	09/594769	2000-06-16	6335710	2002-01-01
P11019 FAM	US	GRANTED	Base station subsystem and method for handling an increase in traffic volume that overloads a terrestrial link in an internet protocol network	09/283652	1999-04-01	6687226	2004-02-03
P11065 FAM	US	GRANTED	A method and an arrangement for preventing metastability	09/588599	2000-06-07	6778620	2004-08-17
P11181 FAM	US	GRANTED	METHOD AND SYSTEM FOR FAST MAXIMUM A-POSTERIORI DECODING	09/252028	1999-02-18	6343368	2002-01-29
P11188 FAM	US	GRANTED	Method and systems for dynamic threshold adjustment for handoffs in radio communication system	09/461029	1999-12-15	6754493	2004-06-22
P11244 FAM	US	GRANTED	Scanning lens antenna	09/454224	1999-12-02	6195059	2001-02-27
P11317 FAM	US	GRANTED	Resonator med variabel resonansfrekvens	09/522399	2000-03-09	6466114	2002-10-15
P11415 FAM	US	GRANTED	Electrically tunable device and a method relating thereto	09/885520	2001-06-20	6563153	2003-05-13
P11514 FAM	US	GRANTED	Automatic Implementation of Channel Plan Change in Cellular Network	10/019692	2000-07-04	6985738	2006-01-10
P11586 FAM	US	GRANTED		09/736321	2000-12-15	6433423	2002-08-13
P11624 FAM	US	GRANTED	System for Increasing Antenna Efficiency	09/621392	2000-07-21	6266019	2001-07-24
P11631 FAM	US	GRANTED	A Dual Band Compact Internal Antenna	09/499976	2000-02-08	6184836	2001-02-06
P11656 FAM	US	GRANTED	Compact, Broadband Inverted-F Antennas with Conductive Elements and Wireless Communicators Incorporating Same	09/512493	2000-02-24	6218992	2001-04-17

Ref No.	Country	Status	Title	App No.	App Date	Patent No.	Patent Date
P11664 FAM	US	GRANTED	MS Supported Private System Roaming	09/474950	1999-12-30	6829480	2004-12-07
P11712 FAM	US	GRANTED		09/631474	2000-08-03	6925072	2005-08-02
P11787 FAM	US	GRANTED	Split Inductor with Fractional Turn of Each Winding and PCB Including Same	09/401573	1999-09-22	6307458	2001-10-23
P11969 FAM	US	GRANTED	An arrangement relating to oscillators	09/658103	2000-09-08	6606006	2003-08-12
P12119 FAM	US	GRANTED	Methods and apparatus for measuring control carrier signal strength in wireless communications systems employing discontinuous control carrier transmissions	09/472881	1999-12-28	6600758	2003-07-29
P12170 FAM	US	GRANTED	METHOD OF AND APPARATUS FOR BEAM REDUCTION AND COMBINING IN A RADIO COMMUNICATIONS SYSTEM	09/374265	1999-08-16	6470192	2002-10-22
P12197 FAM	US	GRANTED	Scanning continuous antenna reflector device	09/717001	2000-11-22	6326931	2001-12-04
P12202 FAM	US	GRANTED	Sparse array antenna	09/657999	2000-09-08	6351243	2002-02-26
P12215 FAM	US	GRANTED	An Antenna for a Portable Communication Apparatus, and a Portable Communication Apparatus Comprising such an Antenna	09/887144	2001-06-22	7053839	2006-05-30
P12231 FAM	US	GRANTED	Anordning vid reflektorantenn	09/748185	2000-12-27	6429826	2002-08-06
P12267 FAM	US	GRANTED	Method and apparatus relating to radio communication	09/749920	2000-12-29	6826410	2004-11-30
P12433 FAM	US	GRANTED	Antenna Systems Having Capacitively Coupled Internal Retractable Antennas and Wireless Communicators Incorporating Same	09/585514	2000-06-01	6225951	2001-05-01
P12441 FAM	US	GRANTED	Notch antennas and wireless communicators incorporating same	09/698600	2000-10-27	6424300	2002-07-23
P12603 FAM	US	GRANTED	Time Interval Based Channel Estimation With Transmit Diversity	09/866241	2001-05-25	6711124	2004-03-23
P12631 FAM	US	GRANTED	Transmitter Apparatus and Methods Using Frequency Doubling Modulation	09/931546	2001-08-16	6480046	2002-11-12

Ref No.	Country	Status	Title	App No.	App Date	Patent No.	Patent Date
P12897 FAM	US	GRANTED	PHYSICAL CHANNEL RELATION SYSTEM/METHOD FOR USE IN CELLULAR TELECOMMUNICATIONS NETWORK	10/000803	2001-12-04	7239621	2007-07-03
P13087 FAM	US	GRANTED	Communications system	09/835479	2001-04-16	6711405	2004-03-23
P13098 FAM	US	GRANTED	Gruppantenn med smalare sidolober i horisontalplanet	09/985634	2001-11-05	6611239	2003-08-26
P13130 FAM	US	GRANTED		10/311588	2001-07-17	7245921	2007-07-17
P13270 FAM	US	GRANTED	System and method for testing a communication system	09/609635	2000-07-03	6662008	2003-12-09
P13619 FAM	US	GRANTED	A multilayer balun transformer structure	10/036665	2001-12-21	6603383	2003-08-05
P13667 FAM	US	GRANTED	Method and apparatus for providing downlink power control in radio communication systems employing virtual cells	09/708526	2000-11-09	6735451	2004-05-11
P13816 FAM	US	GRANTED	Using statistically ascertained position for starting synchronization searcher during diversity handover	09/998921	2001-12-03	6980803	2005-12-27
P13941 FAM	US	GRANTED		09/973805	2001-10-11	6549153	2003-04-15
P13984 FAM	US	GRANTED	Connection procedure	10/479292	2002-05-29	7620007	2009-11-17
P14029 FAM	US	GRANTED	Micro Electromechanical Switches	10/750900	2004-01-05	6930873	2005-08-16
P14029 FAM	US	GRANTED	Micro Electromechanical Switches	10/112046	2002-04-01	6720851	2004-04-13
P14031 FAM	US	GRANTED	Micro Electromechanical Switches	10/112035	2002-04-01	6798321	2004-09-28
P14043 FAM	US	GRANTED	Ferroelectric devices and method relating thereto.	11/229622	2005-09-20	7274277	2007-09-25
P14043 FAM	US	GRANTED	Ferroelectric devices and method relating thereto.	10/704146	2002-05-08	6985054	2006-01-10
P14249 FAM	US	GRANTED	Multiplexing method in a multi carrier transmit diversity system	10/471825	2002-03-01	7477697	2009-01-13
P14252 FAM	US	GRANTED	Printed circuit board integrated switch	10/475137	2001-04-17	7102480	2006-09-05
P14438 FAM	US	GRANTED	An arrangement and a method relating to phase locking	10/947409	2003-03-27	6946916	2005-09-20

Ref No.	Country	Status	Title	App No.	App Date	Patent No.	Patent Date
P14830 FAM	US	GRANTED	APPARATUS AND METHOD FOR CHANNEL REQUEST IN A WIRELESS COMMUNICATION SYSTEM	09/999651	2001-10-30	7457263	2008-11-25
P14832 FAM	US	GRANTED		10/011669	2001-10-29	7061884	2006-06-13
P14879 FAM	US	GRANTED	Speech Recognition Using Microphone Antenna Array	09/970369	2001-10-02	6937980	2005-08-30
P15055 FAM	US	GRANTED	Assembly for mounting power semiconductive modules to heat dissipators	10/077318	2002-02-15	6545352	2003-04-08
P15146 FAM	US	GRANTED	Downlink Load Sharing by Nulling, Beam Steering and Beam Selection	10/185746	2002-06-28	6667712	2003-12-23
P15146 FAM	US	GRANTED	Downlink Load Sharing by Nulling, Beam Steering and Beam Selection	10/661883	2003-09-12	6853333	2005-02-08
P15146 FAM	US	GRANTED	Downlink Load Sharing by Nulling, Beam Steering and Beam Selection	10/661883	2003-09-12	6853333	2005-02-08
P15152 FAM	US	GRANTED	METHOD AND ARRANGEMENT IN A COMMUNICATION SYSTEM	10/157221	2002-05-29	7187664	2007-03-06
P15278 FAM	US	GRANTED	Method and Apparatus for Segmenting a Data Packet	10/012348	2001-12-12	7224703	2007-05-29
P16015 FAM	US	FILED	ASSIGNING TIME SLOTS DURING TRANSMISSION GAPS PF A FIRST PROTOCOL COMMUNICATION TO A SECOND PROTOCOL COMMUNICATION	10/536253	2002-12-19		
P16245 FAM	US	GRANTED	COMPARATOR OFFSET CALIBRATION FOR A/D CONVERTERS	10/509828	2003-02-24	7075465	2006-07-11
P16501 FAM	US	GRANTED	Signal receiver devices and methods	10/506035	2002-05-31	7602866	2009-10-13
P16509 FAM	US	GRANTED	A Substrate Structure, a Method and an Arrangement for Producing Such Substrate Structure	11/225851	2003-03-14	7535094	2009-05-19
P16974 FAM	US	GRANTED	TRANSMISSION LINE	11/298748	2003-06-13	7102456	2006-09-05
P17559 FAM	US	GRANTED	A multiband PLL arrangement and a method of controlling such arrangement	10/595426	2003-10-23	7738618	2010-06-15
P18071 FAM	US	GRANTED	Tunable arrangements	10/597811	2004-02-10	7903040	2011-03-08

Ref No.	Country	Status	Title	App No.	App Date	Patent No.	Patent Date
P18403 FAM	US	GRANTED	RADIO QUALITY BASED CHANNEL RESOURCE MANAGEMENT	11/662386	2004-10-25	8107425	2012-01-31
P18415 FAM	US	GRANTED	A delay locked loop with precision controlled delay	10/581786	2003-12-10	7456664	2008-11-25
P18796 FAM	US	GRANTED	Antenna device, and array antenna, with planar notch element feed	10/584907	2004-12-27	7403169	2008-07-22
P18833 FAM	US	GRANTED	Scanable sparse antenna array	10/580611	2003-11-27	7696945	2010-04-13
P18882 FAM	US	GRANTED	An oscillator circuit with tuneable signal delay means	10/581788	2003-12-10	7352253	2008-04-01
P18918 FAM	US	GRANTED	RESOURCE RESERVATION IN A PACKET SWITCHED TELECOMMUNICATIONS NETWORK	10/596615	2003-12-19	7881196	2011-02-01
P19183 FAM	US	GRANTED	An improved tuneable delay line	10/586139	2004-03-09	7642883	2010-01-05
P19309 FAM	US	GRANTED	A Tuneable resonator	11/573312	2004-07-06	7548142	2009-06-16
P19419 FAM	US	GRANTED	SAIC-compensated modulation scheme management	10/857359	2004-06-01	7471928	2008-12-30
P19469 FAM	US	GRANTED	Pre-alignment outside an antenna measurement range	11/576230	2004-09-30	7667656	2010-02-23
P19727 FAM	US	GRANTED	Coupling net and MMIC amplifier	11/720497	2004-12-03	7489197	2009-02-10
P19834 FAM	US	GRANTED	A phase shifter device	11/915072	2005-06-10	7714681	2010-05-11
P20076 FAM	US	GRANTED	An improved system for cellular telephony, and an antenna for such a system	11/813127	2004-12-30	8068878	2011-11-29
P20140 FAM	US	GRANTED	A tunable circuit arrangement and a method for providing such an arrangement	11/916583	2005-06-09	7936235	2011-05-03
P20215 FAM	US	GRANTED	ISR Title: A COMMUNICATION NODE AND A METHOD FOR ROUTING TRAFFIC IN A COMMUNICATION NETWORK BY CALCULATING AT LEAST ONE METRIC FOR AT LEAST ONE LINK AND A SENSITIVITY PARAMETER FOR SAID METRIC.	11/914657	2005-06-20	8023424	2011-09-20
P20336 FAM	US	GRANTED	AN ARRANGEMENT FOR PEAK-FIELD SUPPRESSION	11/995396	2005-07-15	8218283	2012-07-10



Ref No.	Country	Status	Title	App No.	App Date	Patent No.	Patent Date
P20419 FAM	US	GRANTED	A TRANSDUCTANCE STAGE ARRANGEMENT	12/090710	2005-10-20	7626461	2009-12-01
P20640 FAM	US	GRANTED	Technique for Controlling Handovers within a Multi- Radio Wireless Communication System	11/915706	2005-05-30	8213382	2012-07-03
P20774 FAM	US	GRANTED	OSCILLATING CIRCUIT ARRANGEMENT AND METHOD RELATING THERE TO	12/088972	2005-10-05	7688153	2010-03-30
P20846 FAM	US	GRANTED		11/921179	2006-04-18	8031673	2011-10-04
P20848 FAM	US	GRANTED	ARRAY ANTENNA WITH ENHANCED SCANNING	12/097863	2005-12-23	7855690	2010-12-21
P21027 FAM	US	FILED	METHOD FOR POWER CONTROL IN A WIRELESS STATION	12/090129	2005-10-14		
P21195 FAM	US	FILED	Method and arrangement relating to distribution of control for wireless communications	12/064965	2005-08-29		
P21221 FAM	US	GRANTED	Channel Estimator and Method for Channel Estimation	12/278379	2007-02-08	8121231	2012-02-21
P21314 FAM	US	GRANTED	A SUBHARMONICALLY PUMPED MIXER	12/094310	2005-11-23	8249541	2012-08-21
P21879 FAM	US	GRANTED	TRIMMING OF WAVEGUIDE FILTERS	12/373541	2006-07-13	8183960	2012-05-22
P21880 FAM	US	GRANTED	Method and Arrangement for a Voltage Controlled Oscillator Circuit	12/447804	2006-10-30	7952445	2011-05-31
P22004 FAM	US	GRANTED	METHOD FOR REPETITIVE TRANSMISSIONS IN DIFFERENT DIRECTIONS	12/527535	2007-02-16	8195258	2012-06-05
P22025 FAM	US	GRANTED	A Dual Polarized Waveguide Feed Arrangement	12/520709	2006-12-21	8115565	2012-02-14
P22241 FAM	US	GRANTED	Method and Apparatus for Cancellation of Partially Known Interference Using Transmit Diversity Based Interference Cancellation	11/733333	2007-04-10	8000419	2011-08-16
P22241 FAM	US	GRANTED	Method and Apparatus for Cancellation of Partially Known Interference Using Transmit Diversity Based Interference Cancellation	13/158936	2011-06-13	8265213	2012-09-11
P22425 FAM	US	GRANTED	Method for reducing Delay in a Communication System Employing HARQ	12/447844	2006-11-01	8325650	2012-12-04

Ref No.	Country	Status	Title	App No.	App Date	Patent No.	Patent Date
P22432 FAM	US	GRANTED	Distributing signals for load balancing of power amplifiers	12/441484	2007-09-06	8503402	2013-08-06
P22998 FAM	US	GRANTED		11/684692	2007-03-12	8515377	2013-08-20
P23082 FAM	US	GRANTED	A dual polarized antenna with null-fill	12/598817	2007-05-04	8212732	2012-07-03
P23146 FAM	US	GRANTED	An Oscillator Arrangement	12/665183	2007-06-20	8525604	2013-09-03
P23264 FAM	US	GRANTED	A METHOD OF DETERMINING RADIO CHANNEL CHARACTERISTICS	12/522624	2007-01-10	8200210	2012-06-12
P23328 FAM	US	GRANTED	Continued telecommunication with weak links	12/666203	2007-06-25	8380525	2013-02-19
P23574 FAM	US	GRANTED	CALIBRATION METHOD AND DEVICE IN TELECOMMUNICATION SYSTEM	12/522794	2008-02-06	8401485	2013-03-19
P23583 FAM	US	GRANTED	METHOD AND ARRANGEMENT RELATING TO TELECOMMUNICATIONS	12/522785	2007-02-26	8369461	2013-02-05
P23791 FAM	US	GRANTED	A Method for compensating a radiation beam to beam steering	12/665627	2007-06-21	8260336	2012-09-04
P23830 FAM	US	GRANTED	AN IMPROVED HARTLEY VOLTAGE CONTROLLED OSCILLATOR	12/679932	2007-09-25	8169269	2012-05-01
P23986 FAM	US	FILED	SCHEDULING IN WIRELESS NETWORKS	12/674335	2007-08-21		
P24045 FAM	US	GRANTED	A DUAL-BAND COUPLED VCO	12/739012	2007-10-23	8125282	2012-02-28
P24069 FAM	US	GRANTED	SIGNAL MODULATION FOR SWITCHED MODE POWER AMPLIFIERS	12/676005	2007-09-04	8072283	2011-12-06
P24214 FAM	US	FILED	AGC low threshold signal level detection	12/992692	2008-05-15		
P24390 FAM	US	GRANTED	METHOD AND ARRANGEMENT IN A TELECOMMUNICATION SYSTEM	12/667829	2008-04-23	8553667	2013-10-08
P24503 FAM	US	FILED		12/674020	2008-08-22		
P24506 FAM	US	GRANTED	WCDMA AGC receiver SNR adjustment and signalling	12/991479	2008-05-15	8320865	2012-11-27

Ref No.	Country	Status	Title	App No.	App Date	Patent No.	Patent Date
P24905 FAM	US	GRANTED	Handover optimization: reduction in handover HO interruption latency in wimax PCT title: REDUCTION IN HANDOVER INTERRUPTION IN WIMAX	12/105650	2008-04-18	8126462	2012-02-28
P25207 FAM	US	GRANTED	A combined mixer and balun design	12/920890	2008-03-25	8299838	2012-10-30
P25251 FAM	US	FILED		13/956136	2013-07-31		
P25251 FAM	US	FILED		12/234067	2008-09-19		
P25251 FAM	US	GRANTED		13/281291	2011-10-25	8527843	2013-09-03
P25323 FAM	US	GRANTED	Dual-band Voltage-Controlled Oscillator Arrangement	12/993153	2008-05-30	8344811	2013-01-01
P25790 FAM	US	FILED	A RECONFIGURABLE FILTER APPARATUS	13/062743	2008-09-08		
P25805 FAM	US	GRANTED	Frequency Multiplier	12/997957	2008-06-16	8040166	2011-10-18
P26024 FAM	US	FILED	COORDINATED TRANSMISSION FOR SECONDARY USAGE	13/061969	2008-09-05		
P26267 FAM	US	FILED	An improved large area photo detector	13/128776	2008-11-12		
P26273 FAM	US	GRANTED		12/342439	2008-12-23	8068952	2011-11-29
P26424 FAM	US	FILED (ALL)	User and traffic data retention in lawful interception.	13/126027	2008-10-28		
P26470 FAM	US	FILED (ALL)	A METHOD AND AN ARRANGEMENT FOR DETERMINING AN ADMISSION CONTROL THRESHOLD	13/130445	2008-12-23		
P26554 FAM	US	FILED	Antenna Arrangement, With Improved Isolation between Adjacent Cell Areas	13/061218	2008-08-28		
P26595 FAM	US	FILED	A SYSTEM IN A NETWORK NODE FOR REGULATING TEMPERATURE OF ELECTRONIC EQUIPMENT	13/127188	2008-11-03		
P26719 FAM	US	GRANTED	METHOD AND APPARATUS RELATING TO SPECTRUM SENSING	12/993555	2009-06-04	8270906	2012-09-18
P26720 FAM	US	GRANTED	METHOD AND APPARATUS RELATING TO SPECTRUM SENSING	12/990880	2009-06-01	8509701	2013-08-13

Ref No.	Country	Status	Title	App No.	App Date	Patent No.	Patent Date
P26960 FAM	US	FILED	REPORTING OF MULTIPLE IF/RAT FREQUENCY LAYER RESTRICTIONS	14/056512	2009-07-22		
P26960 FAM	US	GRANTED	REPORTING OF MULTIPLE IF/RAT FREQUENCY LAYER RESTRICTIONS	12/507376	2009-07-22	8588846	2013-11-19
P26963 FAM	US	FILED	METHODS AND ARRANGEMENT IN A COMMUNICATION SYSTEM	13/130854	2008-11-27		
P27031 FAM	US	FILED	METHOD AND APPARATUS FOR ALLOCATING RESOURCES TO USER EQUIPMENTS IN A TELECOMMUNICATIONS SYSTEM	13/263255	2009-04-07		
P27157 FAM	US	FILED	METHODS AND ENTITY FOR CONVEYING DATA UNITS	13/140691	2008-12-19		
P27372 FAM	US	FILED (ALL)	A METHOD AND APPARATUS FOR DYNAMIC TRANSMITTER TO MULTI-CARRIER POWER AMPLIFIER MAPPING	13/142509	2008-12-29		
P27465 FAM	US	FILED (ALL)	MOBILITY SOLUTION SELECTION INDICATOR FOR VOICE OVER EPS	13/144947	2010-01-22		
P27631 FAM	US	FILED	A METHOD OF SENSING	13/129149	2009-03-23		
P27929 FAM	US	FILED	A transition from a chip to a waveguide port	13/319171	2009-05-08		
P27961 FAM	US	FILED	AN IMPROVED OSCILLATOR CIRUCIT	13/264573	2009-04-20		
P27974 FAM	US	FILED (ALL)	An Improved Antenna Arrangement	13/320802	2009-05-27		
P28123 FAM	US	FILED	UE behaviour for GANC discovery in roaming scenarios in CS-over-LTE-via-GAN solutions	13/144327	2010-01-12		
P28148 FAM	US	GRANTED	Automatic mapping between E-UTRAN and GERAN/UTRAN/GAN cells in CS-over-LTE-via-GAN solutions.	13/145232	2010-01-22	8412230	2013-04-02
P28242 FAM	US	FILED	METHOD AND ARRANGEMENT IN A WIRELESS COMMUNICATION SYSTEM	13/148433	2009-06-23		

Ref No.	Country	Status	Title	App No.	App Date	Patent No.	Patent Date
P28293 FAM	US	FILED	PROCESSING NODES AND METHODS OF ESTIMATING INTERFERENCE IN A RADIO TELECOMMUNICATION NETWORK	13/393704	2009-11-06		
P28571 FAM	US	FILED	AN IMPROVED TRANSFORMER	13/391863	2009-08-27		
P28640 FAM	US	FILED	A METHOD FOR ANTENNA CALIBRATION IN A WIDEBAND COMMUNICATION SYSTEM	13/378263	2009-06-17		
P29237 FAM	US	GRANTED	LOCATING A SOURCE OF WIRELESS TRANSMISSIONS FROM A LICENSED USER OF A LICENSED SPECTRAL RESOURCE	12/758744	2010-04-12	8526974	2013-09-03
P29565 FAM	US	FILED	METHOD AND APPARATUS RELATING TO SIGNAL CONTROL	13/509826	2009-12-30		
P29741 FAM	US	FILED	Methods and Arrangements for handling a setup of an S1 Application Protocol signalling connection	13/516504	2009-12-16		
P29836 FAM	US	FILED	METHOD AND ARRANGEMENT IN A WIRELESS COMMUNICATION SYSTEM	13/394219	2009-09-25		
P30207 FAM	US	FILED (ALL)	POWER LOOP CONTROL METHOD AND APPARATUS	12/639032	2009-12-16		
P30299 FAM	US	GRANTED		12/650201	2009-12-30	8401487	2013-03-19
P30338 FAM	US	FILED	A METHOD AND APPARATUS FOR GRANT-BASED UPLINK TRANSMISSION SCHEDULING	13/580840	2010-03-08		
P30367 FAM	US	FILED	COMPONENT CARRIER SELECTION METHOD AND APPARATUS FOR RANDOM ACCESS ATTEMPTS IN A COMMUNICATIONS NETWORK	13/505160	2010-03-11		
P30627 FAM	US	FILED	Partial relaying of message based on interference in wireless network	13/580999	2010-03-23		

Ref No.	Country	Status	Title	App No.	App Date	Patent No.	Patent Date
P30848 FAM	US	FILED	METHOD, APPARATUS AND SYSTEM FOR ANTENNA CALIBRATION	13/699105	2010-05-28		
P30888 FAM	US	FILED		12/972460	2010-12-18		
P31087 FAM	US	FILED	Improved Surge Protection	13/124747	2011-04-18		
P31147 FAM	US	FILED	ISR Title: METHODS AND APPARATUSES FOR POSITIONING A NODE IN A WIRELESS COMMUNICATIONS SYSTEM USING DIFFERENT RAN/RATS	13/575168	2010-09-24		
P31709 FAM	US	GRANTED	METHODS AND DEVICES FOR CARRIER ACTIVATION/ DEACTIVATION IN A MULTI-CARRIER COMMUNICATION SYSTEM	13/049186	2011-03-16	8483302	2013-07-09
P31759 FAM	US	FILED	DYNAMIC ADAPTATION OF DOWNLINK RLC PDU SIZE	13/075254	2011-03-30		
P31785 FAM	US	FILED	ANTENNA DEVICE AND METHOD IN A MIMO SYSTEM	13/824746	2010-09-23		
P32235 FAM	US	GRANTED	APPARATUS AND METHOD FOR CONTROLLING SELF- INTERFERENCE IN A CELLULAR COMMUNICATIONS SYSTEM	13/144784	2011-06-14	8594000	2013-11-26
P32267 FAM	US	FILED (ALL)		13/144766	2010-08-11		
P32371 FAM	US	FILED	Frequency-Domain Subblock Equalization for Uplink LTE to Alleviate Inter-Symbol Interference	13/050210	2011-03-17		
P32454 FAM	US	FILED	METHODS AND ARRANGEMENTS FOR TRANSMIT MODE ADAPTATION	13/981700	2011-01-26		
P32484 FAM	US	FILED	METHOD AND DEVICE RELATING TO RELAY TECHNIQUE	14/005210	2011-03-14		
P32591 FAM	US	FILED	ADAPTIVE MULTI- CHANNEL TRANSMITTER LINEARIZATION SYSTEM USING A SHARED FEEDBACK RECEIVER	13/099518	2011-05-03		

Ref No.	Country	Status	Title	App No.	App Date	Patent No.	Patent Date
P32789 FAM	US	FILED	METHODS PROVIDING AIDED SIGNAL SYNCHRONIZATION AND RELATED NETWORKS AND DEVICES	13/043027	2011-03-08		
P32971 FAM	US	FILED	Radio base station, radio network controller and methods therein	13/992348	2010-12-21		
P33057 FAM	US	FILED	METHODS AND DEVICES FOR PROVIDING GUARANTEED QUALITY OF SERVICE	14/000371	2011-02-18		
P33457 FAM	US	FILED	HYBRID CONGESTION CONTROL	14/004403	2011-03-10		
P33594 FAM	US	FILED	METHOD, APPARATUS AND SYSTEM FOR DETERMINING VOLTAGE STANDING WAVE RATIO IN DOWNLINK PERIOD OF RADIO COMMUNICATION	14/113959	2011-04-29		
P33637 FAM	US	FILED	COMPENSATING TIMING MEASUREMENTS DUE TO FREQUENCY DIFFERENCE	13/257605	2011-08-02		
P33844 FAM	US	FILED	Approved by ISA: METHOD, NODE AND SYSTEM FOR MANAGEMENT OF A MOBILE NETWORK	14/122645	2011-06-01		
P33937 FAM	US	GRANTED		13/155527	2011-06-08	8428525	2013-04-23
P33963 FAM	US	GRANTED		13/155631	2011-06-08	8457642	2013-06-04
P34022 FAM	US	FILED	DEVICE AND METHOD FOR CONTROLLING INTERFERENCE	PCT/EP2012/060245	2012-05-31		
P34099 FAM	US	FILED	RLC DATA TRANSMISSION CONTROL BASED ON UE MEMORY CAPACITY	13/178048	2011-07-07		
P34100 FAM	US	FILED	DIGITAL DOWN CONVERSION AND DEMODULATION	13/271515	2011-10-12		
P34428 FAM	US	GRANTED	LINEARIZATION FOR A SINGLE POWER AMPLIFIER IN A MULTI-BAND TRANSMITTER	13/228926	2011-09-09	8576943	2013-11-05
P34737 FAM	US	FILED	USER EQUIPMENT, NETWORK NODE AND METHODS THEREIN	13/381606	2011-08-15		

Ref No.	Country	Status	Title	App No.	App Date	Patent No.	Patent Date
P34737 FAM	US	FILED	USER EQUIPMENT, NETWORK NODE AND METHODS THEREIN	13/381606	2011-08-15		
P36245 FAM	US	FILED		13/765046	2013-02-12		
P36444 FAM	US	FILED	METHOD AND APPARATUS FOR PILOT POWER ALLOCATION IN A MULTI ANTENNA COMMUNICATION SYSTEM	13/816039	2013-01-22		
P38411 FAM	US	FILED		61/705679	2012-09-26		
P38411 FAM	US	FILED		14/035213	2013-09-24		
P38625 FAM	US	FILED	US1 TITLE: COMMUNICATION PROTOCOL FOR SHORT DATA TRANSMISSIONS	13/722298	2012-12-20		
P38748 FAM	US	FILED		61/707366	2012-09-28		
P38748 FAM	US	FILED		14/039554	2013-09-27		
P63070 FAM	US	GRANTED		10/451588	2001-12-05	7023394	2006-04-04
P63549 FAM	US	GRANTED		10/502312	2003-01-24	6999672	2006-02-14
P63967 FAM	US	GRANTED		10/597212	2005-01-07	7633457	2009-12-15
P64058 FAM	US	GRANTED		12/090175	2006-08-22	7924234	2011-04-12

Ref No.	Country	Status	Title	App No.	App Date	Patent No.	Patent Date
1A	US	GRANTED	Method for scheduling distributed virtual resource blocks	12/349465	2009-01-06	7729377	2010- 06-01
1A	US	GRANTED	Method for scheduling distributed virtual resource blocks	12/759645	2010-04-13	8472466	2013- 06-25
1A	US	GRANTED	Method for scheduling distributed virtual resource blocks	12/868642	2010-08-25	8018966	2011- 09-13



Ref No.	Country	Status	Title	App No.	App Date	Patent No.	Patent Date
1A	US	FILED	Method for scheduling distributed virtual resource blocks	13/409057	2012-02-29	NOA	
2A	US	GRANTED	Method for performing random access procedures and terminal thereof	12/457653	2009-06-17	7933243	2011-04-26
2A	US	GRANTED	Method for performing random access procedures and terminal thereof	13/071280	2011-03-24	8467343	2013-06-18
2A	US	FILED	Method for performing random access procedures and terminal thereof	13/894948	2013-05-15		
3A	US	GRANTED	Data transmitting and receiving method using phase shift based precoding and transceiver supporting the same	12/678200	2010-03-15	7970074	2011-06-28
3A	US	GRANTED	Data transmitting and receiving method using phase shift based precoding and transceiver supporting the same	12/724318	2010-03-15	7961808	2011-06-14
3A	US	GRANTED	Data transmitting and receiving method using phase shift based precoding and transceiver supporting the same	13/109962	2011-05-17	8208576	2012-06-26
3A	US	FILED	Data transmitting and receiving method using phase shift based precoding and transceiver supporting the same	13/109963	2011-05-17		
4A	US	GRANTED	Method of generating reference signal in wireless communication system	12/205530	2008-09-05	7848448	2010-12-07

Ref No.	Country	Status	Title	App No.	App Date	Patent No.	Patent Date
4A	US	GRANTED	Method of generating reference signal in wireless communication system	12/913654	2010-10-27	8098760	2012-01-17
4A	US	FILED	Method of generating reference signal in wireless communication system	13/312809	2011-12-06		
4A	US	FILED	Method of generating reference signal in wireless communication system	13/312804	2011-12-06		
5A	US	GRANTED	Method for transmitting status report of PDCP layer in mobile telecommunications system and receiver of mobile telecommunications	12/523090	2009-07-14	7936723	2011-05-03
5A	US	FILED	Method for transmitting status report of PDCP layer in mobile telecommunications system and receiver of mobile telecommunications	13/051803	2011-03-18	NOA	
6A	US	GRANTED	Method for transmitting uplink signals	12/209136	2008-09-11	8102833	2012-01-24
6A	US	FILED	Method for transmitting uplink signals	13/316315	2011-12-09		
7A	US	FILED	Method for transmitting and receiving control information through PDCCH	13/590048	2012-08-20		
7A	US	GRANTED	Method for transmitting and receiving control information through PDCCH	12/252270	2008-10-15	7873004	2011-01-18

Ref No.	Country	Status	Title	App No.	App Date	Patent No.	Patent Date
7A	US	GRANTED	Method for transmitting and receiving control information through PDCCH	12/963570	2010-12-08	8019332	2011-09-13
7A	US	GRANTED	Method for transmitting and receiving control information through PDCCH	12/963588	2010-12-08	8014769	2011-09-06
7A	US	GRANTED	Method for transmitting and receiving control information through PDCCH	13/185343	2011-07-18	8213377	2012-07-03
7A	US	GRANTED	Method for transmitting and receiving control information through PDCCH	13/185362	2011-07-18	8270363	2012-09-18
8A	US	GRANTED	Method of performing uplink synchronization in random access procedure	12/392654	2009-02-25	7843895	2010-11-30
8A	US	FILED	Method of performing uplink synchronization in random access procedure	12/909780	2010-10-21		
9A	US	GRANTED	Method for transmitting downlink control information	12/363522	2009-01-30	7835337	2010-11-16
10A	US	GRANTED	Method for effectively transmitting control signal in wireless communication system	12/404873	2009-03-16	7774686	2010-08-10
10A	US	GRANTED	Method for effectively transmitting control signal in wireless communication system	12/836403	2010-07-14	8108757	2012-01-31
10A	US	GRANTED	Method for effectively transmitting control signal in wireless communication system	13/563472	2012-07-31	8423858	2013-04-16

Ref No.	Country	Status	Title	App No.	App Date	Patent No.	Patent Date
10A	US	GRANTED	Method for effectively transmitting control signal in wireless communication system	13/345532	2012-01-06	8250443	2012-08-21
10A	US	FILED	Method for effectively transmitting control signal in wireless communication system	13/802066	2013-03-13	NOA	
11A	US	GRANTED	Side button switch in mobile communication terminal and vibration-preventing device thereof	10/341356	2003-01-14	7383066	2008-06-03
12A	US	GRANTED	Apparatus and methods of selecting special characters in a mobile communication terminal	10/036377	2002-01-07	7423647	2008-09-09
12A	US	GRANTED	Apparatus and methods of selecting special characters in a mobile communication terminal	11/147350	2005-06-08	7453462	2008-11-18
12A	US	GRANTED	Apparatus and methods of selecting special characters in a mobile communication terminal	12/247567	2008-10-08	7714868	2010-05-11
13A	US	GRANTED	Portable terminal	11/828978	2007-07-26	7525535	2009-04-28
14A	US	GRANTED	File downloading apparatus and method for mobile communication system	10/465724	2003-06-20	7289817	2007-10-30
14A	US	GRANTED	File downloading apparatus and method for mobile communication system	11/896419	2007-08-31	7634260	2009-12-15

Ref No.	Country	Status	Title	App No.	App Date	Patent No.	Patent Date
15A	US	GRANTED	Method of displaying object and terminal capable of implementing the same	12/648248	2009-12-28	8174506	2012-05-08
15A	US	GRANTED	Method of displaying object and terminal capable of implementing the same	11/729807	2007-03-30	7663610	2010-02-16
16A	US	GRANTED	Method for transmitting VoIP packet	12/673262	2010-02-12	8391311	2013-03-05
16A	US	GRANTED	Method for transmitting VoIP packet	12/705215	2010-02-12	8396070	2013-03-12
1B	US	GRANTED	Mobile terminal having retractable camera	10/607551	2003-06-27	7418280	2008-08-26
2B	US	GRANTED	Data transmission control method for GPRS	10/438032	2003-05-15	7443795	2008-10-28
3B	US	GRANTED	Signal connecting apparatus for a folder type mobile terminal	11/016308	2004-12-17	7229289	2007-06-12
4B	US	GRANTED	Method for operating data communication service in mobile communication system	10/737212	2003-12-15	7349694	2008-03-25
5B	US	GRANTED	System, apparatus, and method for enhancing mobile communication terminal push to talk service	11/325934	2005-12-30	7684814	2010-03-23

Ref No.	Country	Status	Title	App No.	App Date	Patent No.	Patent Date
7B	US	GRANTED	Card ejecting mechanism and mobile communication terminal having the same	11/445825	2006-06-02	7494353	2009-02-24
8B	US	GRANTED	Mobile communication terminal having opening mechanism	11/469063	2006-08-31	7787914	2010-08-31
9B	US	GRANTED	Method for transmitting emergency call of mobile phone	09/671115	2000-09-28	7113764	2006-09-26
10B	US	GRANTED	Method of controlling timing for uplink synchronous transmission scheme	10/078674	2002-02-21	7190691	2007-03-13
11B	US	GRANTED	Apparatus and method for estimating position of mobile communication terminal	10/125531	2002-04-19	7057557	2006-06-06
12B	US	GRANTED	Data receiving and transmitting method with coding type determination	10/192895	2002-07-11	7366119	2008-04-29
13B	US	GRANTED	Apparatus and method for increasing channel capacity of a mobile communication system	10/630721	2003-07-31	7369486	2008-05-06
14B	US	GRANTED	Method for analyzing data transmission throughput in a wireless LAN	10/775240	2004-02-11	7321579	2008-01-22
15B	US	GRANTED	Method for implementing system information broadcasting function in asynchronous mobile communication system	09/974845	2001-10-12	7116648	2006-10-03
16B	US	GRANTED	Mobile communication terminal and method for displaying an image	11/735377	2007-04-13	7881523	2011-02-01

Ref Category	Title	App No.	App Date	Patent No.	Patent Date	Country
Wireless Communication	Reduction method of successive handoffs between base stations in code division multiple access (CDMA) mobile communication system	09/078578	1998/05/14	6301234	2001/10/29	U.S.A.
Wireless Communication	Method of canceling interference components included in received signals of base station in mobile communication system	09/273765	1999/03/22	6574204	2003/06/03	U.S.A.
Wireless Communication	Radio packet data terminal and method of determining internet interworking protocol address	09/224053	1998/12/31	6404754	2002/06/11	U.S.A.
Wireless Communication	Method for controlling power for forward common channel	09/671208	2000/09/28	6615053	2003/09/02	U.S.A.
UI	Mobile terminal and multimedia contents service providing system and method for call connection waiting using the same	11/459223	2006/07/21	7738645	2010/06/15	U.S.A.
UI	Method and apparatus for reproducing multimedia files	11/538424	2006/10/03	8086962	2011/12/27	U.S.A.
Wireless Communication	Fine granularity scalability encoding/decoding apparatus and method	10/659386	2003/09/11	7003034	2006/02/21	U.S.A.
UI	Apparatus and method for providing pause function of broadcasting streaming in terminal	11/322280	2005/12/29	8046483	2011/10/25	U.S.A.
UI	Method of applying for communication service and communication terminal thereof	11/364410	2006/03/01	7720494	2010/05/18	U.S.A.
UI	Character input apparatus and method for mobile communications terminal	11/441139	2006/05/26	7705752	2010/04/27	U.S.A.
UI	Method for downloading a message in a mobile terminal, method for forwarding message, and mobile terminal for performing the same	11/864752	2007/09/28	8160550	2012/04/17	U.S.A.
UI	MOBILE TERMINAL AND METHOD OF DISPLAYING MENU ICON THEREOF	12/176314	2008/07/18	NOA		U.S.A.
UI	Mobile communication terminal for controlling display information	12/111004	2008/04/28	8111255	2012/02/07	U.S.A.
UI	Mobile terminal providing web page-merge function and operating method of the mobile terminal	12/506486	2009/07/20	8532712	2013/09/10	U.S.A.

Ref Category	Title	App No.	App Date	Patent No.	Patent Date	Country
UI	Adjusting the display orientation of an image on a mobile terminal	12/423769	2009/04/14	8564618	2013/10/22	U.S.A.
		10/902801	2004/08/02	7409394	2008/08/05	U.S.A.
UI	Method for managing menu function in mobile station	09/737283	2000/12/15	7137073	2006/11/14	U.S.A.
		11/682957	2007/03/07	8127250	2012/02/28	U.S.A.
		11/549629	2006/10/13	7861184	2010/12/28	U.S.A.
		13/353270	2012/01/18			U.S.A.



**UNITED STATES PATENT AND TRADEMARK OFFICE**

UNITED STATES DEPARTMENT OF COMMERCE  
**United States Patent and Trademark Office**  
 Address: COMMISSIONER FOR PATENTS  
 P.O. Box 1450  
 Alexandria, Virginia 22313-1450  
[www.uspto.gov](http://www.uspto.gov)

APPLICATION NO.	ISSUE DATE	PATENT NO.	ATTORNEY DOCKET NO.	CONFIRMATION NO.
12/209,136	01/24/2012	8102833	2101-3573	3897

35884            7590            01/04/2012  
 LEE, HONG, DEGERMAN, KANG & WAIMEY  
 660 S. FIGUEROA STREET  
 Suite 2300  
 LOS ANGELES, CA 90017

## ISSUE NOTIFICATION

The projected patent number and issue date are specified above.

**Determination of Patent Term Adjustment under 35 U.S.C. 154 (b)**  
 (application filed on or after May 29, 2000)

The Patent Term Adjustment is 725 day(s). Any patent to issue from the above-identified application will include an indication of the adjustment on the front page.

If a Continued Prosecution Application (CPA) was filed in the above-identified application, the filing date that determines Patent Term Adjustment is the filing date of the most recent CPA.

Applicant will be able to obtain more detailed information by accessing the Patent Application Information Retrieval (PAIR) WEB site (<http://pair.uspto.gov>).

Any questions regarding the Patent Term Extension or Adjustment determination should be directed to the Office of Patent Legal Administration at (571)-272-7702. Questions relating to issue and publication fee payments should be directed to the Application Assistance Unit (AAU) of the Office of Data Management (ODM) at (571)-272-4200.

APPLICANT(s) (Please see PAIR WEB site <http://pair.uspto.gov> for additional applicants):

Dae Won Lee, Gyeonggi-do, KOREA, REPUBLIC OF;  
 Bong Hoe Kim, Gyeonggi-do, KOREA, REPUBLIC OF;  
 Young Woo Yun, Gyeonggi-do, KOREA, REPUBLIC OF;  
 Ki Jun Kim, Gyeonggi-do, KOREA, REPUBLIC OF;  
 Dong Wook Roh, Gyeonggi-do, KOREA, REPUBLIC OF;  
 Hak Seong Kim, Gyeonggi-do, KOREA, REPUBLIC OF;  
 Hyun Wook Park, Gyeonggi-do, KOREA, REPUBLIC OF;

Complete and send this form, together with applicable fee(s), to: **Mail** Mail Stop ISSUE FEE  
Commissioner for Patents  
P.O. Box 1450  
Alexandria, Virginia 22313-1450  
or **Fax** (571)-273-2885

INSTRUCTIONS: This form should be used for transmitting the ISSUE FEE and PUBLICATION FEE (if required). Blocks 1 through 5 should be completed where appropriate. All further correspondence including the Patent, advance orders and notification of maintenance fees will be mailed to the current correspondence address as indicated unless corrected below or directed otherwise in Block 1, by (a) specifying a new correspondence address; and/or (b) indicating a separate "FEE ADDRESS" for maintenance fee notifications.

CURRENT CORRESPONDENCE ADDRESS (Note: Use Block 1 for any change of address)

Note: A certificate of mailing can only be used for domestic mailings of the Fee(s) Transmittal. This certificate cannot be used for any other accompanying papers. Each additional paper, such as an assignment or formal drawing, must have its own certificate of mailing or transmission.

35884 7590 11/15/2011  
LEE, HONG, DEGERMAN, KANG & WAIMEY  
660 S. FIGUEROA STREET  
Suite 2300  
LOS ANGELES, CA 90017

**Certificate of Mailing or Transmission**

I hereby certify that this Fee(s) Transmittal is being deposited with the United States Postal Service with sufficient postage for first class mail in an envelope addressed to the Mail Stop ISSUE FEE address above, or being facsimile transmitted to the USPTO (571) 273-2885, on the date indicated below.

(Depositor's name)
(Signature)
(Date)

APPLICATION NO.	FILING DATE	FIRST NAMED INVENTOR	ATTORNEY DOCKET NO.	CONFIRMATION NO.
12/209,136	09/11/2008	Dae Won Lee	2101-3573	3897

TITLE OF INVENTION: METHOD FOR TRANSMITTING UPLINK SIGNALS

APPLN. TYPE	SMALL ENTITY	ISSUE FEE DUE	PUBLICATION FEE DUE	PREV. PAID ISSUE FEE	TOTAL FEE(S) DUE	DATE DUE
nonprovisional	NO	\$1740	\$300	\$0	\$2040	02/15/2012

EXAMINER	ART UNIT	CLASS-SUBCLASS
YEUNG, MANG HANG	2463	370-344000

1. Change of correspondence address or indication of "Fee Address" (37 CFR 1.363).

- Change of correspondence address (or Change of Correspondence Address form PTO/SB/122) attached.  
 "Fee Address" indication (or "Fee Address" Indication form PTO/SB/47; Rev 03-02 or more recent) attached. **Use of a Customer Number is required.**

2. For printing on the patent front page, list

- (1) the names of up to 3 registered patent attorneys or agents OR, alternatively,  
(2) the name of a single firm (having as a member a registered attorney or agent) and the names of up to 2 registered patent attorneys or agents. If no name is listed, no name will be printed.

1 LEE, HONG, DEGERMAN, KANG & WAIMEY  
2 \_\_\_\_\_  
3 \_\_\_\_\_

3. ASSIGNEE NAME AND RESIDENCE DATA TO BE PRINTED ON THE PATENT (print or type)

PLEASE NOTE: Unless an assignee is identified below, no assignee data will appear on the patent. If an assignee is identified below, the document has been filed for recordation as set forth in 37 CFR 3.11. Completion of this form is NOT a substitute for filing an assignment.

(A) NAME OF ASSIGNEE: **LG ELECTRONICS INC.**  
(B) RESIDENCE: (CITY and STATE OR COUNTRY) **SEOUL, REPUBLIC OF KOREA**

Please check the appropriate assignee category or categories (will not be printed on the patent):  Individual  Corporation or other private group entity  Government

4a. The following fee(s) are submitted:

- Issue Fee  
 Publication Fee (No small entity discount permitted)  
 Advance Order - # of Copies \_\_\_\_\_

4b. Payment of Fee(s); (Please first reapply any previously paid issue fee shown above)

- A check is enclosed.  
 Payment by credit card. Form PTO-2038 is attached.  
 The Director is hereby authorized to charge the required fee(s), any deficiency, or credit any overpayment, to Deposit Account Number 50-2290 (enclose an extra copy of this form).

5. Change in Entity Status (from status indicated above)

- a. Applicant claims SMALL ENTITY status. See 37 CFR 1.27.  b. Applicant is no longer claiming SMALL ENTITY status. See 37 CFR 1.27(g)(2).

NOTE: The Issue Fee and Publication Fee (if required) will not be accepted from anyone other than the applicant; a registered attorney or agent; or the assignee or other party in interest as shown by the records of the United States Patent and Trademark Office.

Authorized Signature /Puya Partow-Navid/ Date December 16, 2011  
Typed or printed name Puya Partow-Navid Registration No. 59,657

This collection of information is required by 37 CFR 1.311. The information is required to obtain or retain a benefit by the public which is to file (and by the USPTO to process) an application. Confidentiality is governed by 35 U.S.C. 122 and 37 CFR 1.14. This collection is estimated to take 12 minutes to complete, including gathering, preparing, and submitting the completed application form to the USPTO. Time will vary depending upon the individual case. Any comments on the amount of time you require to complete this form and/or suggestions for reducing this burden, should be sent to the Chief Information Officer, U.S. Patent and Trademark Office, U.S. Department of Commerce, P.O. Box 1450, Alexandria, Virginia 22313-1450. DO NOT SEND FEES OR COMPLETED FORMS TO THIS ADDRESS. SEND TO: Commissioner for Patents, P.O. Box 1450, Alexandria, Virginia 22313-1450.

Under the Paperwork Reduction Act of 1995, no persons are required to respond to a collection of information unless it displays a valid OMB control number.

## Electronic Patent Application Fee Transmittal

<b>Application Number:</b>	12209136			
<b>Filing Date:</b>	11-Sep-2008			
<b>Title of Invention:</b>	METHOD FOR TRANSMITTING UPLINK SIGNALS			
<b>First Named Inventor/Applicant Name:</b>	Dae Won Lee			
<b>Filer:</b>	Puya Partow-Navid/Nicolette Silva			
<b>Attorney Docket Number:</b>	2101-3573			
Filed as Large Entity				
<b>Utility under 35 USC 111(a) Filing Fees</b>				
<b>Description</b>	<b>Fee Code</b>	<b>Quantity</b>	<b>Amount</b>	<b>Sub-Total in USD(\$)</b>
<b>Basic Filing:</b>				
<b>Pages:</b>				
<b>Claims:</b>				
<b>Miscellaneous-Filing:</b>				
<b>Petition:</b>				
<b>Patent-Appeals-and-Interference:</b>				
<b>Post-Allowance-and-Post-Issuance:</b>				
Utility Appl issue fee	1501	1	1740	1740
Publ. Fee- early, voluntary, or normal	1504	1	300	300

Description	Fee Code	Quantity	Amount	Sub-Total in USD(\$)
<b>Extension-of-Time:</b>				
<b>Miscellaneous:</b>				
<b>Total in USD (\$)</b>				<b>2040</b>

## Electronic Acknowledgement Receipt

<b>EFS ID:</b>	11644113
<b>Application Number:</b>	12209136
<b>International Application Number:</b>	
<b>Confirmation Number:</b>	3897
<b>Title of Invention:</b>	METHOD FOR TRANSMITTING UPLINK SIGNALS
<b>First Named Inventor/Applicant Name:</b>	Dae Won Lee
<b>Customer Number:</b>	35884
<b>Filer:</b>	Puya Partow-Navid/Nicolette Silva
<b>Filer Authorized By:</b>	Puya Partow-Navid
<b>Attorney Docket Number:</b>	2101-3573
<b>Receipt Date:</b>	16-DEC-2011
<b>Filing Date:</b>	11-SEP-2008
<b>Time Stamp:</b>	18:03:28
<b>Application Type:</b>	Utility under 35 USC 111(a)

### Payment information:

Submitted with Payment	yes
Payment Type	Credit Card
Payment was successfully received in RAM	\$2040
RAM confirmation Number	5370
Deposit Account	
Authorized User	

### File Listing:

Document Number	Document Description	File Name	File Size(Bytes)/ Message Digest	Multi Part /.zip	Pages (if appl.)
-----------------	----------------------	-----------	-------------------------------------	------------------	------------------

1	Miscellaneous Incoming Letter	1_2101-3573-Transmittal-IssueFee.pdf	455792 7a1db3724d6c61cef209d387bcb6337067e dafad	no	1
<b>Warnings:</b>					
<b>Information:</b>					
2	Issue Fee Payment (PTO-85B)	2_2101-3573_PartB.pdf	2160694 95855631baad0fa28279784e9e4101bf2e0 bd625	no	1
<b>Warnings:</b>					
<b>Information:</b>					
3	Fee Worksheet (SB06)	fee-info.pdf	32029 9e280fec4f87697d6abf11d62eaa8e5ec2da a68e	no	2
<b>Warnings:</b>					
<b>Information:</b>					
<b>Total Files Size (in bytes):</b>				2648515	

**This Acknowledgement Receipt evidences receipt on the noted date by the USPTO of the indicated documents, characterized by the applicant, and including page counts, where applicable. It serves as evidence of receipt similar to a Post Card, as described in MPEP 503.**

**New Applications Under 35 U.S.C. 111**

**If a new application is being filed and the application includes the necessary components for a filing date (see 37 CFR 1.53(b)-(d) and MPEP 506), a Filing Receipt (37 CFR 1.54) will be issued in due course and the date shown on this Acknowledgement Receipt will establish the filing date of the application.**

**National Stage of an International Application under 35 U.S.C. 371**

**If a timely submission to enter the national stage of an international application is compliant with the conditions of 35 U.S.C. 371 and other applicable requirements a Form PCT/DO/EO/903 indicating acceptance of the application as a national stage submission under 35 U.S.C. 371 will be issued in addition to the Filing Receipt, in due course.**

**New International Application Filed with the USPTO as a Receiving Office**

**If a new international application is being filed and the international application includes the necessary components for an international filing date (see PCT Article 11 and MPEP 1810), a Notification of the International Application Number and of the International Filing Date (Form PCT/RO/105) will be issued in due course, subject to prescriptions concerning national security, and the date shown on this Acknowledgement Receipt will establish the international filing date of the application.**

Customer No. 035884

Attorney Docket No.: 2101-3573

IN THE UNITED STATES PATENT AND TRADEMARK OFFICE

In re application of:

Dae Won Lee

Serial No: 12/209,136

Filed: September 11, 2008

For: METHOD FOR TRANSMITTING UPLINK  
SIGNALS

Art Unit: 2463

Examiner: Mang Hang Yeung

Conf. No.: 3897

**TRANSMITTAL OF ISSUE FEE**

Mail Stop ISSUE FEE

Commissioner for Patents

P.O. Box 1450

Alexandria, VA 22313-1450

Dear Sir:

In response to the Notice of Allowance dated November 15, 2011, enclosed are the following:

- Form Part B - Issue Fee Transmittal.
- Inventor(s) or Assignee(s) is entitled to **LARGE** entity.
- Issue Fee payment in the amount of \$2,040 via credit card.
- The Commissioner is hereby authorized to charge any deficiency in payment or credit any overpayment to **Deposit Account No. 502290**.

Respectfully submitted,

Lee, Hong, Degerman, Kang & Waimey

Date: December 16, 2011

By: /Puya Partow-Navid/  
Puya Partow-Navid  
Registration No. 59,657  
Attorney for Applicant(s)

**UNITED STATES PATENT AND TRADEMARK OFFICE**

UNITED STATES DEPARTMENT OF COMMERCE  
**United States Patent and Trademark Office**  
 Address: COMMISSIONER FOR PATENTS  
 P.O. Box 1450  
 Alexandria, Virginia 22313-1450  
 www.uspto.gov

**NOTICE OF ALLOWANCE AND FEE(S) DUE**

35884 7590 11/15/2011  
 LEE, HONG, DEGERMAN, KANG & WAIMEY  
 660 S. FIGUEROA STREET  
 Suite 2300  
 LOS ANGELES, CA 90017

EXAMINER	
YEUNG, MANG HANG	
ART UNIT	PAPER NUMBER
2463	

DATE MAILED: 11/15/2011

APPLICATION NO.	FILING DATE	FIRST NAMED INVENTOR	ATTORNEY DOCKET NO.	CONFIRMATION NO.
12/209,136	09/11/2008	Dae Won Lee	2101-3573	3897

TITLE OF INVENTION: METHOD FOR TRANSMITTING UPLINK SIGNALS

APPLN. TYPE	SMALL ENTITY	ISSUE FEE DUE	PUBLICATION FEE DUE	PREV. PAID ISSUE FEE	TOTAL FEE(S) DUE	DATE DUE
nonprovisional	NO	\$1740	\$300	\$0	\$2040	02/15/2012

**THE APPLICATION IDENTIFIED ABOVE HAS BEEN EXAMINED AND IS ALLOWED FOR ISSUANCE AS A PATENT. PROSECUTION ON THE MERITS IS CLOSED. THIS NOTICE OF ALLOWANCE IS NOT A GRANT OF PATENT RIGHTS. THIS APPLICATION IS SUBJECT TO WITHDRAWAL FROM ISSUE AT THE INITIATIVE OF THE OFFICE OR UPON PETITION BY THE APPLICANT. SEE 37 CFR 1.313 AND MPEP 1308.**

**THE ISSUE FEE AND PUBLICATION FEE (IF REQUIRED) MUST BE PAID WITHIN THREE MONTHS FROM THE MAILING DATE OF THIS NOTICE OR THIS APPLICATION SHALL BE REGARDED AS ABANDONED. THIS STATUTORY PERIOD CANNOT BE EXTENDED. SEE 35 U.S.C. 151. THE ISSUE FEE DUE INDICATED ABOVE DOES NOT REFLECT A CREDIT FOR ANY PREVIOUSLY PAID ISSUE FEE IN THIS APPLICATION. IF AN ISSUE FEE HAS PREVIOUSLY BEEN PAID IN THIS APPLICATION (AS SHOWN ABOVE), THE RETURN OF PART B OF THIS FORM WILL BE CONSIDERED A REQUEST TO REAPPLY THE PREVIOUSLY PAID ISSUE FEE TOWARD THE ISSUE FEE NOW DUE.**

**HOW TO REPLY TO THIS NOTICE:**

I. Review the SMALL ENTITY status shown above.

If the SMALL ENTITY is shown as YES, verify your current SMALL ENTITY status:

A. If the status is the same, pay the TOTAL FEE(S) DUE shown above.

B. If the status above is to be removed, check box 5b on Part B - Fee(s) Transmittal and pay the PUBLICATION FEE (if required) and twice the amount of the ISSUE FEE shown above, or

If the SMALL ENTITY is shown as NO:

A. Pay TOTAL FEE(S) DUE shown above, or

B. If applicant claimed SMALL ENTITY status before, or is now claiming SMALL ENTITY status, check box 5a on Part B - Fee(s) Transmittal and pay the PUBLICATION FEE (if required) and 1/2 the ISSUE FEE shown above.

II. PART B - FEE(S) TRANSMITTAL, or its equivalent, must be completed and returned to the United States Patent and Trademark Office (USPTO) with your ISSUE FEE and PUBLICATION FEE (if required). If you are charging the fee(s) to your deposit account, section "4b" of Part B - Fee(s) Transmittal should be completed and an extra copy of the form should be submitted. If an equivalent of Part B is filed, a request to reapply a previously paid issue fee must be clearly made, and delays in processing may occur due to the difficulty in recognizing the paper as an equivalent of Part B.

III. All communications regarding this application must give the application number. Please direct all communications prior to issuance to Mail Stop ISSUE FEE unless advised to the contrary.

**IMPORTANT REMINDER: Utility patents issuing on applications filed on or after Dec. 12, 1980 may require payment of maintenance fees. It is patentee's responsibility to ensure timely payment of maintenance fees when due.**



**Complete and send this form, together with applicable fee(s), to: Mail Mail Stop ISSUE FEE  
Commissioner for Patents  
P.O. Box 1450  
Alexandria, Virginia 22313-1450  
or Fax (571)-273-2885**

**INSTRUCTIONS:** This form should be used for transmitting the ISSUE FEE and PUBLICATION FEE (if required). Blocks 1 through 5 should be completed where appropriate. All further correspondence including the Patent, advance orders and notification of maintenance fees will be mailed to the current correspondence address as indicated unless corrected below or directed otherwise in Block 1, by (a) specifying a new correspondence address; and/or (b) indicating a separate "FEE ADDRESS" for maintenance fee notifications.

CURRENT CORRESPONDENCE ADDRESS (Note: Use Block 1 for any change of address)

Note: A certificate of mailing can only be used for domestic mailings of the Fee(s) Transmittal. This certificate cannot be used for any other accompanying papers. Each additional paper, such as an assignment or formal drawing, must have its own certificate of mailing or transmission.

35884 7590 11/15/2011  
LEE, HONG, DEGERMAN, KANG & WAIMEY  
660 S. FIGUEROA STREET  
Suite 2300  
LOS ANGELES, CA 90017

**Certificate of Mailing or Transmission**

I hereby certify that this Fee(s) Transmittal is being deposited with the United States Postal Service with sufficient postage for first class mail in an envelope addressed to the Mail Stop ISSUE FEE address above, or being facsimile transmitted to the USPTO (571) 273-2885, on the date indicated below.

(Depositor's name)
(Signature)
(Date)

APPLICATION NO.	FILING DATE	FIRST NAMED INVENTOR	ATTORNEY DOCKET NO.	CONFIRMATION NO.
12/209,136	09/11/2008	Dae Won Lee	2101-3573	3897

TITLE OF INVENTION: METHOD FOR TRANSMITTING UPLINK SIGNALS

APPLN. TYPE	SMALL ENTITY	ISSUE FEE DUE	PUBLICATION FEE DUE	PREV. PAID ISSUE FEE	TOTAL FEE(S) DUE	DATE DUE
nonprovisional	NO	\$1740	\$300	\$0	\$2040	02/15/2012

EXAMINER	ART UNIT	CLASS-SUBCLASS
YEUNG, MANG HANG	2463	370-344000

<p>1. Change of correspondence address or indication of "Fee Address" (37 CFR 1.363).</p> <p><input type="checkbox"/> Change of correspondence address (or Change of Correspondence Address form PTO/SB/122) attached.</p> <p><input type="checkbox"/> "Fee Address" indication (or "Fee Address" Indication form PTO/SB/47; Rev 03-02 or more recent) attached. <b>Use of a Customer Number is required.</b></p>	<p>2. For printing on the patent front page, list</p> <p>(1) the names of up to 3 registered patent attorneys or agents OR, alternatively, 1 _____</p> <p>(2) the name of a single firm (having as a member a registered attorney or agent) and the names of up to 2 registered patent attorneys or agents. If no name is listed, no name will be printed. 2 _____</p> <p>3 _____</p>
---	---

3. ASSIGNEE NAME AND RESIDENCE DATA TO BE PRINTED ON THE PATENT (print or type)

PLEASE NOTE: Unless an assignee is identified below, no assignee data will appear on the patent. If an assignee is identified below, the document has been filed for recordation as set forth in 37 CFR 3.11. Completion of this form is NOT a substitute for filing an assignment.

(A) NAME OF ASSIGNEE \_\_\_\_\_ (B) RESIDENCE: (CITY and STATE OR COUNTRY) \_\_\_\_\_

Please check the appropriate assignee category or categories (will not be printed on the patent) :  Individual  Corporation or other private group entity  Government

<p>4a. The following fee(s) are submitted:</p> <p><input type="checkbox"/> Issue Fee</p> <p><input type="checkbox"/> Publication Fee (No small entity discount permitted)</p> <p><input type="checkbox"/> Advance Order - # of Copies _____</p>	<p>4b. Payment of Fee(s); (Please first reapply any previously paid issue fee shown above)</p> <p><input type="checkbox"/> A check is enclosed.</p> <p><input type="checkbox"/> Payment by credit card. Form PTO-2038 is attached.</p> <p><input type="checkbox"/> The Director is hereby authorized to charge the required fee(s), any deficiency, or credit any overpayment, to Deposit Account Number _____ (enclose an extra copy of this form).</p>
---	--

5. Change in Entity Status (from status indicated above)

a. Applicant claims SMALL ENTITY status. See 37 CFR 1.27.  b. Applicant is no longer claiming SMALL ENTITY status. See 37 CFR 1.27(g)(2).

NOTE: The Issue Fee and Publication Fee (if required) will not be accepted from anyone other than the applicant; a registered attorney or agent; or the assignee or other party in interest as shown by the records of the United States Patent and Trademark Office.

Authorized Signature \_\_\_\_\_ Date \_\_\_\_\_

Typed or printed name \_\_\_\_\_ Registration No. \_\_\_\_\_

This collection of information is required by 37 CFR 1.311. The information is required to obtain or retain a benefit by the public which is to file (and by the USPTO to process) an application. Confidentiality is governed by 35 U.S.C. 122 and 37 CFR 1.14. This collection is estimated to take 12 minutes to complete, including gathering, preparing, and submitting the completed application form to the USPTO. Time will vary depending upon the individual case. Any comments on the amount of time you require to complete this form and/or suggestions for reducing this burden, should be sent to the Chief Information Officer, U.S. Patent and Trademark Office, U.S. Department of Commerce, P.O. Box 1450, Alexandria, Virginia 22313-1450. DO NOT SEND FEES OR COMPLETED FORMS TO THIS ADDRESS. SEND TO: Commissioner for Patents, P.O. Box 1450, Alexandria, Virginia 22313-1450.

Under the Paperwork Reduction Act of 1995, no persons are required to respond to a collection of information unless it displays a valid OMB control number.

**UNITED STATES PATENT AND TRADEMARK OFFICE**

UNITED STATES DEPARTMENT OF COMMERCE  
**United States Patent and Trademark Office**  
 Address: COMMISSIONER FOR PATENTS  
 P.O. Box 1450  
 Alexandria, Virginia 22313-1450  
 www.uspto.gov

APPLICATION NO.	FILING DATE	FIRST NAMED INVENTOR	ATTORNEY DOCKET NO.	CONFIRMATION NO.
12/209,136	09/11/2008	Dae Won Lee	2101-3573	3897

35884 7590 11/15/2011  
**LEE, HONG, DEGERMAN, KANG & WAIMEY**  
 660 S. FIGUEROA STREET  
 Suite 2300  
 LOS ANGELES, CA 90017

EXAMINER
----------

YEUNG, MANG HANG

ART UNIT	PAPER NUMBER
----------	--------------

2463

DATE MAILED: 11/15/2011

**Determination of Patent Term Adjustment under 35 U.S.C. 154 (b)**  
 (application filed on or after May 29, 2000)

The Patent Term Adjustment to date is 590 day(s). If the issue fee is paid on the date that is three months after the mailing date of this notice and the patent issues on the Tuesday before the date that is 28 weeks (six and a half months) after the mailing date of this notice, the Patent Term Adjustment will be 590 day(s).

If a Continued Prosecution Application (CPA) was filed in the above-identified application, the filing date that determines Patent Term Adjustment is the filing date of the most recent CPA.

Applicant will be able to obtain more detailed information by accessing the Patent Application Information Retrieval (PAIR) WEB site (<http://pair.uspto.gov>).

Any questions regarding the Patent Term Extension or Adjustment determination should be directed to the Office of Patent Legal Administration at (571)-272-7702. Questions relating to issue and publication fee payments should be directed to the Customer Service Center of the Office of Patent Publication at 1-(888)-786-0101 or (571)-272-4200.

## Privacy Act Statement

**The Privacy Act of 1974 (P.L. 93-579)** requires that you be given certain information in connection with your submission of the attached form related to a patent application or patent. Accordingly, pursuant to the requirements of the Act, please be advised that: (1) the general authority for the collection of this information is 35 U.S.C. 2(b)(2); (2) furnishing of the information solicited is voluntary; and (3) the principal purpose for which the information is used by the U.S. Patent and Trademark Office is to process and/or examine your submission related to a patent application or patent. If you do not furnish the requested information, the U.S. Patent and Trademark Office may not be able to process and/or examine your submission, which may result in termination of proceedings or abandonment of the application or expiration of the patent.

The information provided by you in this form will be subject to the following routine uses:

1. The information on this form will be treated confidentially to the extent allowed under the Freedom of Information Act (5 U.S.C. 552) and the Privacy Act (5 U.S.C. 552a). Records from this system of records may be disclosed to the Department of Justice to determine whether disclosure of these records is required by the Freedom of Information Act.
2. A record from this system of records may be disclosed, as a routine use, in the course of presenting evidence to a court, magistrate, or administrative tribunal, including disclosures to opposing counsel in the course of settlement negotiations.
3. A record in this system of records may be disclosed, as a routine use, to a Member of Congress submitting a request involving an individual, to whom the record pertains, when the individual has requested assistance from the Member with respect to the subject matter of the record.
4. A record in this system of records may be disclosed, as a routine use, to a contractor of the Agency having need for the information in order to perform a contract. Recipients of information shall be required to comply with the requirements of the Privacy Act of 1974, as amended, pursuant to 5 U.S.C. 552a(m).
5. A record related to an International Application filed under the Patent Cooperation Treaty in this system of records may be disclosed, as a routine use, to the International Bureau of the World Intellectual Property Organization, pursuant to the Patent Cooperation Treaty.
6. A record in this system of records may be disclosed, as a routine use, to another federal agency for purposes of National Security review (35 U.S.C. 181) and for review pursuant to the Atomic Energy Act (42 U.S.C. 218(c)).
7. A record from this system of records may be disclosed, as a routine use, to the Administrator, General Services, or his/her designee, during an inspection of records conducted by GSA as part of that agency's responsibility to recommend improvements in records management practices and programs, under authority of 44 U.S.C. 2904 and 2906. Such disclosure shall be made in accordance with the GSA regulations governing inspection of records for this purpose, and any other relevant (i.e., GSA or Commerce) directive. Such disclosure shall not be used to make determinations about individuals.
8. A record from this system of records may be disclosed, as a routine use, to the public after either publication of the application pursuant to 35 U.S.C. 122(b) or issuance of a patent pursuant to 35 U.S.C. 151. Further, a record may be disclosed, subject to the limitations of 37 CFR 1.14, as a routine use, to the public if the record was filed in an application which became abandoned or in which the proceedings were terminated and which application is referenced by either a published application, an application open to public inspection or an issued patent.
9. A record from this system of records may be disclosed, as a routine use, to a Federal, State, or local law enforcement agency, if the USPTO becomes aware of a violation or potential violation of law or regulation.

<b>Notice of Allowability</b>	<b>Application No.</b>	<b>Applicant(s)</b>	
	12/209,136	LEE ET AL.	
	<b>Examiner</b>	<b>Art Unit</b>	
	MANG YEUNG	2463	

**-- The MAILING DATE of this communication appears on the cover sheet with the correspondence address--**

All claims being allowable, PROSECUTION ON THE MERITS IS (OR REMAINS) CLOSED in this application. If not included herewith (or previously mailed), a Notice of Allowance (PTOL-85) or other appropriate communication will be mailed in due course. **THIS NOTICE OF ALLOWABILITY IS NOT A GRANT OF PATENT RIGHTS.** This application is subject to withdrawal from issue at the initiative of the Office or upon petition by the applicant. See 37 CFR 1.313 and MPEP 1308.

1.  This communication is responsive to 9/6/2011.
2.  An election was made by the applicant in response to a restriction requirement set forth during the interview on \_\_\_\_\_; the restriction requirement and election have been incorporated into this action.
3.  The allowed claim(s) is/are 9, 10, 12, 14 - 17, 27, 28, 30 and 32 - 35 (renumbered as claims 1 - 14).
4.  Acknowledgment is made of a claim for foreign priority under 35 U.S.C. § 119(a)-(d) or (f).
  - a)  All    b)  Some\*    c)  None    of the:
    1.  Certified copies of the priority documents have been received.
    2.  Certified copies of the priority documents have been received in Application No. \_\_\_\_\_.
    3.  Copies of the certified copies of the priority documents have been received in this national stage application from the International Bureau (PCT Rule 17.2(a)).

\* Certified copies not received: \_\_\_\_\_.

Applicant has THREE MONTHS FROM THE "MAILING DATE" of this communication to file a reply complying with the requirements noted below. Failure to timely comply will result in ABANDONMENT of this application.  
**THIS THREE-MONTH PERIOD IS NOT EXTENDABLE.**

5.  A SUBSTITUTE OATH OR DECLARATION must be submitted. Note the attached EXAMINER'S AMENDMENT or NOTICE OF INFORMAL PATENT APPLICATION (PTO-152) which gives reason(s) why the oath or declaration is deficient.
6.  CORRECTED DRAWINGS ( as "replacement sheets") must be submitted.
  - (a)  including changes required by the Notice of Draftsperson's Patent Drawing Review ( PTO-948) attached
    - 1)  hereto or 2)  to Paper No./Mail Date \_\_\_\_\_.
  - (b)  including changes required by the attached Examiner's Amendment / Comment or in the Office action of Paper No./Mail Date \_\_\_\_\_.

**Identifying indicia such as the application number (see 37 CFR 1.84(c)) should be written on the drawings in the front (not the back) of each sheet. Replacement sheet(s) should be labeled as such in the header according to 37 CFR 1.121(d).**
7.  DEPOSIT OF and/or INFORMATION about the deposit of BIOLOGICAL MATERIAL must be submitted. Note the attached Examiner's comment regarding REQUIREMENT FOR THE DEPOSIT OF BIOLOGICAL MATERIAL.

**Attachment(s)**

- |   |  |
|---|--|
| <ol style="list-style-type: none"> <li>1. <input type="checkbox"/> Notice of References Cited (PTO-892)</li> <li>2. <input type="checkbox"/> Notice of Draftsperson's Patent Drawing Review (PTO-948)</li> <li>3. <input type="checkbox"/> Information Disclosure Statements (PTO/SB/08), Paper No./Mail Date _____</li> <li>4. <input type="checkbox"/> Examiner's Comment Regarding Requirement for Deposit of Biological Material</li> </ol> | <ol style="list-style-type: none"> <li>5. <input type="checkbox"/> Notice of Informal Patent Application</li> <li>6. <input type="checkbox"/> Interview Summary (PTO-413), Paper No./Mail Date _____.</li> <li>7. <input type="checkbox"/> Examiner's Amendment/Comment</li> <li>8. <input checked="" type="checkbox"/> Examiner's Statement of Reasons for Allowance</li> <li>9. <input type="checkbox"/> Other _____.</li> </ol> |
|---|--|

/Derrick W Ferris/  
Supervisory Patent Examiner, Art Unit 2463

Application/Control Number: 12/209,136

Page 2

Art Unit: 2463

**DETAILED ACTION**

1. This Office Action is in response to the application **12/209136** filed on **09/06/20011**
2. **Claims 1 – 8, 11, 13, 18 – 26, 29, 31 and 36 - 44** were cancelled. **Claims 9, 12, 14, 16, 17, 27, 30, 32, 34 and 35** were amended. Pending claims include **claims 9, 10, 12, 14 - 17, 27, 28, 30 and 32 – 35.**

**Allowable Subject Matter**

1. **Claims 9, 10, 12, 14 - 17, 27, 28, 30 and 32 – 35** (renumbered as claims 1 – 14) are allowed. The following is an examiner's statement of reasons for allowance:
2. **Claim 9** is allowed over the prior art of record because the Examiner found neither prior art cited in its entirety, nor based on the prior art found any motivation to combine any of the said prior art reference which teach the limitations “[a] **method for transmitting uplink signals comprising control signals and data signals in a wireless communication system, the method comprising: (a) serially multiplexing first control signals and data signals in a mobile station, wherein the first control signals are placed at a front part of the multiplexed signals and the data signals are placed at a rear part of the multiplexed signals; (b) mapping the multiplexed signals to a 2-dimensional resource matrix comprising a plurality of columns and a plurality of rows wherein the columns and the rows of the 2-dimensional resource matrix correspond to single carrier frequency divisional multiple access (SC-FDMA) symbols and subcarriers for each SC- FDMA symbol, respectively, wherein a**

Application/Control Number: 12/209,136

Page 3

Art Unit: 2463

**number of columns of the 2-dimensional resource matrix corresponds to a number of SC-FDMA symbols within one subframe except specific SC-FDMA symbols used for a reference signal, and wherein the multiplexed signals are mapped from the first column of the first row to the last column of the first row, the first column of the second row to the last column of the second row, and so on, until all the multiplexed signals are mapped to the 2-dimensional resource matrix (c) mapping ACK/NACK control signals to specific columns of the 2-dimensional resource matrix, wherein the specific columns correspond to SC-FDMA symbols right adjacent to the specific SC-FDMA symbols, wherein the ACK/NACK control signals overwrite some of the multiplexed signals mapped to the 2-dimensional resource matrix at step (b) from the last row of the specific columns; and (d) transmitting the signals mapped to the 2-dimensional resource matrix at steps (b) and (c) by column by column to a base station, subcarriers corresponding to symbols near the symbol on which the reference signal is mapped”** with respect to the additional claimed subject matter and in particular the specific boundaries as recited in the claim. **Claims 10, 12, 14 – 17** are also allowed since they depend on **claim 1**.

3. **Claim 27** is allowed over the prior art of record because the Examiner found neither prior art cited in its entirety, nor based on the prior art found any motivation to combine any of the said prior art reference which teach the limitations “[a] **mobile station for transmitting uplink signals comprising control signals and data signals in a wireless communication system, the mobile station comprising: a processor serially multiplexing first control signals and data signals, wherein the first control signals are placed at a front part of the multiplexed signals**

Application/Control Number: 12/209,136

Page 4

Art Unit: 2463

**and the data signals are placed at a rear part of the multiplexed signals; the processor sequentially mapping the multiplexed signals to a 2-dimensional resource matrix comprising a plurality of columns and a plurality of rows, wherein the columns and the rows of the 2-dimensional resource matrix correspond to single carrier frequency divisional multiple access (SC-FDMA) and subcarriers for each SC-FDMA symbol, respectively, wherein a number of columns of the 2-dimensional resource matrix corresponds to a number of SC-FDMA symbols within one subframe except specific SC-FDMA symbols used for a reference signal, and wherein the multiplexed signals are mapped from the first column of the first row to the last column of the first row, the first column of the second row to the last column of the second row, and so on, until all the multiplexed signals are mapped to the 2-dimensional resource matrix; and the processor mapping ACK/NACK control signals to specific columns of the 2-dimensional resource matrix, wherein the specific columns correspond to SC-FDMA symbols right adjacent to the specific SC-FDMA symbols, wherein the ACK/NACK control signals overwrite some of the multiplexed signals mapped to the 2-dimensional resource matrix from the last row of the specific columns subcarriers corresponding to symbols near the symbol on which the reference signal is mapped”** with respect to the additional claimed subject matter and in particular the specific boundaries as recited in the claim. **Claims 28, 30, 32 – 35** are also allowed since they depend on **claim 27**.

4. Any comments considered necessary by applicant must be submitted no later than the payment of the issue fee and, to avoid processing delays, should preferably accompany the issue

Application/Control Number: 12/209,136

Page 5

Art Unit: 2463

fee. Such submissions should be clearly labeled "Comments on Statement of Reasons for Allowance."

### **Conclusion**

Any inquiry concerning this communication or earlier communications from the examiner should be directed to MANG YEUNG whose telephone number is (571) 270-7319. The examiner can normally be reached on Mon to Th (9:00am to 5:00pm EST).

If attempts to reach the examiner by telephone are unsuccessful, the examiner's supervisor, Derrick W. Ferris can be reached on 571-272-3123. The fax phone number for the organization where this application or proceeding is assigned is 571-273-8300.

Information regarding the status of an application may be obtained from the Patent Application Information Retrieval (PAIR) system. Status information for published applications may be obtained from either Private PAIR or Public PAIR. Status information for unpublished applications is available through Private PAIR only. For more information about the PAIR system, see <http://pair-direct.uspto.gov>. Should you have questions on access to the Private PAIR system, contact the Electronic Business Center (EBC) at 866-217-9197 (toll-free). If you would like assistance from a USPTO Customer Service Representative or access to the automated information system, call 800-786-9199 (IN USA OR CANADA) or 571-272-1000.

/M.Y./

/Derrick W Ferris/

Supervisory Patent Examiner, Art Unit 2463



## EAST Search History

## EAST Search History (Prior Art)

Ref #	Hits	Search Query	DBs	Default Operator	Plurals	Time Stamp
L25	384	(SC\$1FDMA (single adj carrier adj frequency adj divisional adj multiple adj access\$3)) and ((ack nack ack\$1nack\$1 nack\$1ack\$1 acknowlegd\$5) same (subcarrier\$1 sub\$1carrier carrier frequenc\$3 sub\$1band\$1 subband) same ((channel adj quality adj indicator) (precod\$3 adj matrix adj index) CQI PMI reference control\$4 "RS" pilot\$3)) same (frame sub\$frame subframe slot subslot sub\$1slot symbol\$1)	US-PGPUB; USPAT; EPO; JPO; DERWENT	OR	ON	2011/10/26 14:59
L22	229	L15 and (370/208,252,294,295,315,319,328,329,330,335,336,338,344.ccls. 455/450,509.ccls.)	US-PGPUB; USPAT; EPO; JPO; DERWENT	OR	ON	2011/10/26 14:36
L21	267	L19 and (370/208,252,294,295,315,319,328,329,330,335,336,338,344.ccls. 455/450,509.ccls.)	US-PGPUB; USPAT; EPO; JPO; DERWENT	OR	ON	2011/10/26 14:35
L19	420	(SC\$1FDMA (single adj carrier adj frequency adj divisional adj multiple adj access\$3)) and (symbol\$1 with frame sub\$frame subframe slot subslot sub\$1slot) with (ack nack ack\$1nack\$1 nack\$1ack\$1 acknowlegd\$5)	US-PGPUB; USPAT; EPO; JPO; DERWENT	OR	ON	2011/10/26 14:33
L15	375	(SC\$1FDMA (single adj carrier adj frequency adj divisional adj multiple adj access\$3)) and ((ack nack ack\$1nack\$1 nack\$1ack\$1 acknowlegd\$5) with (CQI PMI reference control\$4 "RS" pilot\$3)) with (frame sub\$frame subframe slot subslot sub\$1slot symbol\$1)	US-PGPUB; USPAT; EPO; JPO; DERWENT	OR	ON	2011/10/26 14:29
L13	690	(SC\$1FDMA (single adj carrier adj frequency adj divisional adj multiple adj access\$3)) and (symbol\$1 with frame sub\$frame subframe slot subslot sub\$1slot) same (ack nack ack\$1nack\$1 nack\$1ack\$1 acknowlegd\$5)	US-PGPUB; USPAT; EPO; JPO; DERWENT	OR	ON	2011/10/26 14:26
L8	12	(SC\$1FDMA (single adj carrier adj frequency adj divisional adj multiple adj access\$3)) and ((ack nack ack\$1nack\$1ack\$1ack\$1 acknowlegd\$5) same (tile\$1))	US-PGPUB; USPAT; EPO; JPO; DERWENT	OR	ON	2011/10/26 14:23
L7	13	(SC\$1FDMA (single adj carrier adj frequency adj divisional adj multiple adj access\$3)) and ((ack nack ack\$1nack\$1ack\$1ack\$1 acknowlegd\$5) same (row same (col column)))	US-PGPUB; USPAT; EPO; JPO; DERWENT	OR	ON	2011/10/26 14:22

S78	316	(SC\$1FDMA (single adj carrier adj frequency adj divisional adj multiple adj access\$3)) and ((acknowledg\$5) same (subcarrier\$1 sub\$1carrier carrier frequenc\$3 sub\$1band\$1 subband) same (CQI PMI reference control\$4 "RS" pilot\$3)) same (frame sub\$frame subframe slot subslot sub\$1slot)	US-PGPUB; USPAT; EPO; JPO; DERWENT	OR	ON	2011/10/25 12:45
S77	286	(SC\$1FDMA (single adj carrier adj frequency adj divisional adj multiple adj access\$3)) and ((acknowledg\$5) same (subcarrier\$1 sub\$1carrier carrier frequenc\$3 sub\$1band\$1 subband) same (CQI PMI reference control\$4 "RS")) same (frame sub\$frame subframe)	US-PGPUB; USPAT; EPO; JPO; DERWENT	OR	ON	2011/10/25 12:44
S76	286	SC\$1FDMA and ((acknowledg\$5) same (subcarrier\$1 sub\$1carrier carrier frequenc\$3 sub\$1band\$1 subband) same (CQI PMI reference control\$4 "RS")) same (frame sub\$frame subframe)	US-PGPUB; USPAT; EPO; JPO; DERWENT	OR	ON	2011/10/25 12:14
S75	586	SC\$1FDMA and ((acknowledg\$5) same (subcarrier\$1 sub\$1carrier carrier frequenc\$3 sub\$1band\$1 subband) same (CQI PMI reference control\$4 "RS"))	US-PGPUB; USPAT; EPO; JPO; DERWENT	OR	ON	2011/10/25 12:13
S74	586	SC\$1FDMA and (acknowledg\$5) same (subcarrier\$1 sub\$1carrier carrier frequenc\$3 sub\$1band\$1 subband) same (CQI PMI reference control\$4 "RS")	US-PGPUB; USPAT; EPO; JPO; DERWENT	OR	ON	2011/10/25 12:10
S73	575	SC\$1FDMA and (acknowledg\$5) same (subcarrier\$1 sub\$1carrier carrier frequenc\$3 sub\$1band\$1 subband) same (CQI PMI reference control\$4)	US-PGPUB; USPAT; EPO; JPO; DERWENT	OR	ON	2011/10/25 12:09
S72	232	SC\$1FDMA and (acknowledg\$5) same (subcarrier\$1 sub\$1carrier carrier frequenc\$3 sub\$1band\$1 subband) same reference	US-PGPUB; USPAT; EPO; JPO; DERWENT	OR	ON	2011/10/25 11:02
S71	708	SC\$1FDMA and (acknowledg\$5) same (subcarrier\$1 sub\$1carrier carrier frequenc\$3 sub\$1band\$1 subband)	US-PGPUB; USPAT; EPO; JPO; DERWENT	OR	ON	2011/10/25 10:15
S70	12	SC\$1FDMA and (tile) same (acknowledg\$5)	US-PGPUB; USPAT; EPO; JPO; DERWENT	OR	ON	2011/10/25 10:03
S69	506	SC\$1FDMA and (acknowledg\$5) same (symbol\$2)	US-PGPUB; USPAT; EPO; JPO; DERWENT	OR	ON	2011/10/25 09:49

S68	1877	SC\$1FDMA and (ack acknowledg\$5)	US-PGPUB; USPAT; EPO; JPO; DERWENT	OR	ON	2011/10/25 09:49
S67	38	SC\$1FDMA and (col columns tile) same (ack acknowledg\$5)	US-PGPUB; USPAT; EPO; JPO; DERWENT	OR	ON	2011/10/25 09:48
S66	538	SC\$1FDMA and (col columns tile)	US-PGPUB; USPAT; EPO; JPO; DERWENT	OR	ON	2011/10/25 09:47
S65	14	S64 and (370/206,278,344.cds.)	US-PGPUB; USPAT; EPO; JPO; DERWENT	OR	ON	2011/06/15 15:20
S64	280	(ack acknowledg\$5 nack) same (CQI PMI) same reference same (carrier\$1 sub \$1channel subchannel channel sub\$1carrier\$1 subcarrier tone\$1)	US-PGPUB; USPAT; EPO; JPO; DERWENT	OR	ON	2011/06/15 15:20
S63	3	"20060098568"	US-PGPUB; USPAT; EPO; JPO; DERWENT	OR	ON	2011/06/15 15:08
S62	167	S61 and ("370".clas. "455".clas.)	US-PGPUB; USPAT; EPO; JPO; DERWENT	OR	ON	2011/06/15 14:01
S61	268	( encod\$3 ) same (CQI PMI) same (ack acknowledg\$5 nack)	US-PGPUB; USPAT; EPO; JPO; DERWENT	OR	ON	2011/06/15 14:00
S60	126	S59 and ("370".clas. "455".clas.)	US-PGPUB; USPAT; EPO; JPO; DERWENT	OR	ON	2011/06/15 13:28
S59	158	(CRC (cyclic adj;2 check\$3)) same (CQI PMI) same (ack acknowledg\$5 nack)	US-PGPUB; USPAT; EPO; JPO; DERWENT	OR	ON	2011/06/15 13:28

S58	313	S57 and ("370".clas. "455".clas.)	US-PGPUB; USPAT; EPO; JPO; DERWENT	OR	ON	2011/06/15 13:27
S57	454	((channel near cod\$3) encod\$3 CRC (cyclic adj2 check\$3)) same (CQI PMI) same (ack acknowledg\$5 nack)	US-PGPUB; USPAT; EPO; JPO; DERWENT	OR	ON	2011/06/15 13:27
S56	217	S55 and ("370".clas. "455".clas.)	US-PGPUB; USPAT; EPO; JPO; DERWENT	OR	ON	2011/06/15 13:03
S55	334	((channel near cod\$3) encod\$3) same (CQI PMI) same (ack acknowledged\$5 nack)	US-PGPUB; USPAT; EPO; JPO; DERWENT	OR	ON	2011/06/15 13:03
S54	94	(channel near cod\$3) same (CQI PMI) same (ack acknowledged\$5 nack)	US-PGPUB; USPAT; EPO; JPO; DERWENT	OR	ON	2011/06/15 12:59
S53	227	S52 and ("370".clas. "455".clas.)	US-PGPUB; USPAT; EPO; JPO; DERWENT	OR	ON	2011/06/15 10:24
S52	280	(ack acknowledged\$5 nack) same (CQI PMI) same reference same (carrier\$1 sub \$1channel subchannel channel sub\$1carrier\$1 subcarrier tone\$1)	US-PGPUB; USPAT; EPO; JPO; DERWENT	OR	ON	2011/06/15 10:24
S51	170	SC\$1FDMA and (ack acknowledged\$5 nack) same (CQI PMI) same reference	US-PGPUB; USPAT; EPO; JPO; DERWENT	OR	ON	2011/06/15 09:20
S50	15	enhanced adj data same "326"	US-PGPUB; USPAT; EPO; JPO; DERWENT	OR	ON	2011/06/15 09:16
S49	0	enhanced adj data adj "326"	US-PGPUB; USPAT; EPO; JPO; DERWENT	OR	ON	2011/06/15 09:16

S48	81	(PMI CQI) same (acknowledg\$5 nack) same (carrier\$1 sub\$1channel subchannel channel sub\$1carrier\$1 subcarrier tone\$1) same (symbol\$1 data) same mobile and MIMO	US-PGPUB; USPAT; EPO; JPO; DERWENT	OR	ON	2011/06/15 09:15
S47	21	SC\$1FDMA same (acknowledg\$5 nack) same (CQI PMI) same reference	US-PGPUB; USPAT; EPO; JPO; DERWENT	OR	ON	2011/06/14 15:15
S46	18	SC\$1FDMA same (acknowledg\$5 nack) same (CQI PMI) same reference same (carrier\$1 sub\$1channel subchannel channel sub\$1carrier\$1 subcarrier tone\$1)	US-PGPUB; USPAT; EPO; JPO; DERWENT	OR	ON	2011/06/14 15:14
S45	145	SC\$1FDMA and (acknowledg\$5 nack) same (CQI PMI) same reference same (carrier\$1 sub\$1channel subchannel channel sub\$1carrier\$1 subcarrier tone\$1)	US-PGPUB; USPAT; EPO; JPO; DERWENT	OR	ON	2011/06/14 14:52
S44	120	SC\$1FDMA and (acknowledg\$5 nack) same (CQI PMI) same symbol\$1 same (carrier\$1 sub\$1channel subchannel channel sub\$1carrier\$1 subcarrier tone\$1)	US-PGPUB; USPAT; EPO; JPO; DERWENT	OR	ON	2011/06/14 14:35
S43	471	S42 and ("370".clas. "455".clas.)	US-PGPUB; USPAT; EPO; JPO; DERWENT	OR	ON	2011/06/14 14:35
S42	557	SC\$1FDMA and (acknowledg\$5 nack) same (CQI PMI) same (carrier\$1 sub\$1channel subchannel channel sub\$1carrier\$1 subcarrier tone\$1)	US-PGPUB; USPAT; EPO; JPO; DERWENT	OR	ON	2011/06/14 14:34
S41	494	S40 and ("370".clas. "455".clas.)	US-PGPUB; USPAT; EPO; JPO; DERWENT	OR	ON	2011/06/14 14:34
S40	595	SC\$1FDMA and (acknowledg\$5 nack) same (CQI PMI)	US-PGPUB; USPAT; EPO; JPO; DERWENT	OR	ON	2011/06/14 14:34
S39	65	SC\$1FDMA same (acknowledg\$5 nack) same (CQI PMI)	US-PGPUB; USPAT; EPO; JPO; DERWENT	OR	ON	2011/06/14 14:34

S38	153	SC\$1FDMA same (acknowledg\$5 nack)	US-PGPUB; USPAT; EPO; JPO; DERWENT	OR	ON	2011/06/14 14:33
S37	4531	SC\$1FDMA	US-PGPUB; USPAT; EPO; JPO; DERWENT	OR	ON	2011/06/14 14:32
S36	224	S35 and ("370".clas. "455".clas.)	US-PGPUB; USPAT; EPO; JPO; DERWENT	OR	ON	2011/06/14 13:51
S35	263	(PMI CQI) same (acknowledg\$5 nack) same (carrier\$1 sub\$1channel subchannel channel sub\$1carrier\$1 subcarrier tone\$1) same (symbol\$1 data) same mobile	US-PGPUB; USPAT; EPO; JPO; DERWENT	OR	ON	2011/06/14 13:51
S33	81	CQI same (acknowledg\$5 nack) same (carrier\$1 sub\$1channel subchannel channel sub\$1carrier\$1 subcarrier tone\$1) same (symbol\$1 data) same mobile and MIMO	US-PGPUB; USPAT; EPO; JPO; DERWENT	OR	ON	2011/06/14 12:38
S32	329	S31 and ("370".clas. "455".clas.)	US-PGPUB; USPAT; EPO; JPO; DERWENT	OR	ON	2011/06/14 12:38
S31	407	CQI same (acknowledg\$5 nack) same (carrier\$1 sub\$1channel subchannel channel sub\$1carrier\$1 subcarrier tone\$1) same (symbol\$1 data) and MIMO	US-PGPUB; USPAT; EPO; JPO; DERWENT	OR	ON	2011/06/14 12:38
S30	550	S29 and ("370".clas. "455".clas.)	US-PGPUB; USPAT; EPO; JPO; DERWENT	OR	ON	2011/06/14 12:26
S29	637	CQI same (acknowledg\$5 nack) same (carrier\$1 sub\$1channel subchannel channel sub\$1carrier\$1 subcarrier tone\$1) same (symbol\$1 data) same (mobile UE (user adj equipment))	US-PGPUB; USPAT; EPO; JPO; DERWENT	OR	ON	2011/06/14 12:26
S28	263	CQI same (acknowledg\$5 nack) same (carrier\$1 sub\$1channel subchannel channel sub\$1carrier\$1 subcarrier tone\$1) same (symbol\$1 data) same mobile	US-PGPUB; USPAT; EPO; JPO; DERWENT	OR	ON	2011/06/14 12:25

S27	1222	QCI same (acknowledged\$5 nack) same (carrier\$1 sub\$1channel subchannel channel sub\$1carrier\$1 subcarrier tone\$1) same (symbol\$1 data)	US-PGPUB; USPAT; EPO; JPO; DERWENT	OR	ON	2011/06/14 12:24
S26	1851	QCI same (acknowledged\$5 nack) same (carrier\$1 sub\$1channel subchannel channel sub\$1carrier\$1 subcarrier tone\$1)	US-PGPUB; USPAT; EPO; JPO; DERWENT	OR	ON	2011/06/14 12:23
S25	2058	(QCI same (acknowledged\$5 nack))	US-PGPUB; USPAT; EPO; JPO; DERWENT	OR	ON	2011/06/14 12:23
S24	120	MIMO and ((ARQ HARQ) same (acknowledged\$5 nack) same (carrier\$1 sub\$1channel subchannel channel sub\$1carrier\$1 subcarrier tone\$1)) same symbol\$1	US-PGPUB; USPAT; EPO; JPO; DERWENT	OR	ON	2011/06/14 10:45
S23	754	MIMO and ((ARQ HARQ) same (acknowledged\$5 nack) same (carrier\$1 sub\$1channel subchannel channel sub\$1carrier\$1 subcarrier tone\$1))	US-PGPUB; USPAT; EPO; JPO; DERWENT	OR	ON	2011/06/14 10:45
S22	754	MIMO and (ARQ HARQ) same (acknowledged\$5 nack) same (carrier\$1 sub\$1channel subchannel channel sub\$1carrier\$1 subcarrier tone\$1)	US-PGPUB; USPAT; EPO; JPO; DERWENT	OR	ON	2011/06/14 10:44
S21	1171	MIMO and (ARQ HARQ) and (acknowledged\$5 nack) same (carrier\$1 sub\$1channel subchannel channel sub\$1carrier\$1 subcarrier tone\$1)	US-PGPUB; USPAT; EPO; JPO; DERWENT	OR	ON	2011/06/14 10:44
S18	106	((time\$1first (time adj first)) near2 map\$4)	US-PGPUB; USPAT; EPO; JPO; DERWENT	OR	ON	2011/06/14 10:22
S17	106	((time\$1first (time adj first)) near2 map\$4)	US-PGPUB; USPAT; EPO; JPO; DERWENT	OR	ON	2011/06/14 10:21
S16	10	((time\$1first (time adj first)) near2 map\$4) same (ack nack acknowledged\$5)	US-PGPUB; USPAT; EPO; JPO; DERWENT	OR	ON	2011/06/14 10:16

S15	106	((time\$1first (time adj first)) near2 map\$4)	US-PGPUB; USPAT; EPO; JPO; DERWENT	OR	ON	2011/06/14 10:16
S14	675	((cyclic near2 check) CRC) same (ack acknowledg\$5 nack) same (subcarrier\$1 sub \$1carrier\$1 channel\$1 subchannel\$1 sub\$1channel\$1 tone\$1) same (cod\$3)	US-PGPUB; USPAT; EPO; JPO; DERWENT	OR	ON	2011/06/14 09:42
S13	47	((cyclic near2 check) CRC) same (ack acknowledg\$5 nack) same (subcarrier\$1 sub \$1carrier\$1 channel\$1 subchannel\$1 sub\$1channel\$1 tone\$1) same (ofdm fdma)	US-PGPUB; USPAT; EPO; JPO; DERWENT	OR	ON	2011/06/14 09:40
S12	33	((cyclic near2 check) CRC) same (ack acknowledg\$5 nack) same (subcarrier\$1 sub \$1carrier\$1 channel\$1 subchannel\$1 sub\$1channel\$1 tone\$1) same ofdm	US-PGPUB; USPAT; EPO; JPO; DERWENT	OR	ON	2011/06/14 09:40
S11	1555	((cyclic near2 check) CRC) same (ack acknowledg\$5 nack) same (subcarrier\$1 sub \$1carrier\$1 channel\$1 subchannel\$1 sub\$1channel\$1 tone\$1)	US-PGPUB; USPAT; EPO; JPO; DERWENT	OR	ON	2011/06/14 09:40
S10	5559	((cyclic near2 check) CRC) same (ack acknowledg\$5 nack)	US-PGPUB; USPAT; EPO; JPO; DERWENT	OR	ON	2011/06/14 09:36
S9	109	symbol\$1 same (ack nack acknowledg\$5) same (subcarrier\$1 sub\$1carrier\$1 carrier tons) same (frame subframe sub\$1frame\$1) and ofdm	US-PGPUB; USPAT; EPO; JPO; DERWENT	OR	ON	2011/06/13 11:17
S8	152	symbol\$1 same (ack nack acknowledg\$5) same (subcarrier\$1 sub\$1carrier\$1 carrier tons) same ofdm	US-PGPUB; USPAT; EPO; JPO; DERWENT	OR	ON	2011/06/13 11:16
S7	38	symbol\$1 same (ack nack acknowledg\$5) same (subcarrier\$1 sub\$1carrier\$1 carrier tons) same reference same ofdm	US-PGPUB; USPAT; EPO; JPO; DERWENT	OR	ON	2011/06/13 11:16
S6	163	symbol\$1 same (ack nack acknowledg\$5 respon\$5) same (subcarrier\$1 sub\$1carrier \$1 carrier tons) same reference same ofdm	US-PGPUB; USPAT; EPO; JPO; DERWENT	OR	ON	2011/06/13 11:11



S5	1524	symbol\$1 same (ack nack acknowledg\$5 respon\$5) same (subcarrier\$1 sub\$1carrier\$1 carrier tons) same ofdm	US-PGPUB; USPAT; EPO; JPO; DERWENT	OR	ON	2011/06/13 11:10
S4	6	US-1569403-\$.DID. OR EP-20050831-\$.DID. OR US-1806867-\$.DID. OR EP-20070711-\$.DID. OR US-1811701-\$.DID. OR EP-20070725-\$.DID.	US-PGPUB; USPAT; USOCR	OR	ON	2011/06/13 10:54
S3	2	US-20050232138-\$.DID. OR US-20050286402-\$.DID. OR KR-20051206-\$.DID. OR KR-20040701-\$.DID.	US-PGPUB; USPAT; USOCR	OR	ON	2011/06/13 10:54
S2	2	"20090097466"	US-PGPUB; USPAT; EPO; JPO; DERWENT	OR	ON	2011/06/13 10:52
S1	1	"12209136"	US-PGPUB; USPAT; EPO; JPO; DERWENT	OR	ON	2011/06/13 10:52

## EAST Search History (Interference)

Ref #	Hits	Search Query	DBs	Default Operator	Plurals	Time Stamp
L27	3	L26 and (370/208,252,294,295,315,319,328,329,330,335,336,338,344.ccls. 455/450,509.ccls.)	USPAT; UPAD	OR	ON	2011/10/26 15:01
L26	4	((SC\$1FDMA (single adj carrier adj frequency adj divisional adj multiple adj access\$3)) and ((ack nack ack\$1nack\$1 nack\$1ack\$1 acknowledg\$5) and ((channel adj quality adj indicator) (precod\$3 adj matrix adj index) CQI PMI reference control\$4 "RS" pilot\$3)) and (frame sub\$frame subframe slot subslot sub\$1slot symbol\$1)).cml.	USPAT; UPAD	OR	ON	2011/10/26 15:00

10/26/2011 3:01:40 PM

C:\Documents and Settings\myeung\My Documents\EAST\Workspaces\12209136\12209136.wsp



<b>Search Notes</b>  	<b>Application/Control No.</b>  12209136	<b>Applicant(s)/Patent Under Reexamination</b>  LEE ET AL.
	<b>Examiner</b>  MANG YEUNG	<b>Art Unit</b>  2463

**SEARCHED**

Class	Subclass	Date	Examiner
370	206,278,344	6/15/2011	/M.Y./
370	208,252,294,295,315,319,328,329,330,335,336,338,344.	10/26/2011	/M.Y./
455	450,509	10/26/2011	/M.Y./

**SEARCH NOTES**

Search Notes	Date	Examiner
370/206,278,344 with limited text searching (see EAST Search History)	6/15/2011	/M.Y./
Inventor search (Palm)	6/15/2011	/M.Y./
370/208,252,294,295,315,319,328,329,330,335,336,338,344. and 455/450,509. with limited text searching (See EAST search history)	10/26/2011	/M.Y./
Inventor search (Palm)	10/26/2011	/M.Y./
Google scholar search (inventors)	10/26/2011	/M.Y./
interference search (see EAST search history)	10/26/2011	/M.Y./

**INTERFERENCE SEARCH**

Class	Subclass	Date	Examiner
370	344,319	10/26/2011	/M.Y./

/MANG YEUNG/  
Examiner.Art Unit 2463

<b><i>Index of Claims</i></b>  	<b>Application/Control No.</b>  12209136	<b>Applicant(s)/Patent Under Reexamination</b>  LEE ET AL.
	<b>Examiner</b>  MANG YEUNG	<b>Art Unit</b>  2463

✓	<b>Rejected</b>
=	<b>Allowed</b>

-	<b>Cancelled</b>
÷	<b>Restricted</b>

N	<b>Non-Elected</b>
I	<b>Interference</b>

A	<b>Appeal</b>
O	<b>Objected</b>

Claims renumbered in the same order as presented by applicant
  CPA
  T.D.
  R.1.47

CLAIM		DATE							
Final	Original	06/15/2011	10/26/2011						
	1	-	-						
	2	-	-						
	3	-	-						
	4	-	-						
	5	-	-						
	6	-	-						
	7	-	-						
	8	-	-						
1	9	✓	=						
2	10	✓	=						
	11	✓	-						
3	12	✓	=						
	13	✓	-						
4	14	✓	=						
5	15	✓	=						
6	16	✓	=						
7	17	✓	=						
	18	✓	-						
	19	✓	-						
	20	✓	-						
	21	✓	-						
	22	✓	-						
	23	✓	-						
	24	✓	-						
	25	✓	-						
	26	✓	-						
8	27	✓	=						
9	28	✓	=						
	29	✓	-						
10	30	✓	=						
	31	✓	-						
11	32	✓	=						
12	33	✓	=						
13	34	✓	=						
14	35	✓	=						
	36	✓	-						

<b><i>Index of Claims</i></b>  	<b>Application/Control No.</b>  12209136	<b>Applicant(s)/Patent Under Reexamination</b>  LEE ET AL.
	<b>Examiner</b>  MANG YEUNG	<b>Art Unit</b>  2463

✓	<b>Rejected</b>
=	<b>Allowed</b>

-	<b>Cancelled</b>
÷	<b>Restricted</b>

N	<b>Non-Elected</b>
I	<b>Interference</b>

A	<b>Appeal</b>
O	<b>Objected</b>

Claims renumbered in the same order as presented by applicant
  CPA
  T.D.
  R.1.47

CLAIM		DATE							
Final	Original	06/15/2011	10/26/2011						
	37	✓	-						
	38	✓	-						
	39	✓	-						
	40	✓	-						
	41	✓	-						
	42	✓	-						
	43	✓	-						
	44	✓	-						

**Customer No. 035884**

**Attorney Docket No.: 2101-3573**

**IN THE UNITED STATES PATENT AND TRADEMARK OFFICE**

In re application of:

Dae Won Lee

Serial No: 12/209,136

Filed: September 11, 2008

For: METHOD FOR TRANSMITTING UPLINK  
SIGNALS

Art Unit: 2463

Examiner: Mang Hang Yeung

Conf. No.: 3897

**AMENDMENT**

Mail Stop Amendment  
Commissioner for Patents  
P.O. Box 1450  
Alexandria, VA 22313-1450

Sir:

This paper is in response to the Office Action dated June 24, 2011, in connection with the above-identified application, the response to which is due September 24, 2011. Please charge any fees and credit any overpayment to our deposit account No. 502290. Please enter and consider the following amendments and remarks:

**Amendment to the Claims:**

**Please amend the claims as follows:**

1-8. (Canceled)

9. (Currently amended) A method for transmitting uplink signals comprising control signals and data signals in a wireless communication system, the method comprising:

(a) serially multiplexing first control signals and data signals in a mobile station, wherein the first control signals are placed at a front part of the multiplexed signals and the data signals are placed at a rear part of the multiplexed signals;

(b) sequentially mapping the multiplexed signals to a 2-dimensional resource matrix comprising time-frequency resource map according to a time-first mapping method, wherein the time-frequency resource map comprises a plurality of columns symbols and a plurality of rows, wherein the columns and the rows of the 2-dimensional resource matrix correspond to single carrier frequency divisional multiple access (SC-FDMA) symbols and subcarriers for each SC-FDMA symbol, respectively, wherein a number of columns of the 2-dimensional resource matrix corresponds to a number of SC-FDMA symbols within one subframe except specific SC-FDMA symbols used for a reference signal, and wherein the multiplexed signals are mapped from the first column of the first row to the last column of the first row, the first column of the second row to the last column of the second row, and so on, until all the multiplexed signals are mapped to the 2-dimensional resource matrix subcarriers for each symbol, and a reference signal is mapped to at least one subcarrier corresponding to one of the plurality of symbols; and

(c) mapping ACK/NACK control signals to specific columns of the 2-dimensional resource matrix, wherein the specific columns correspond to SC-FDMA symbols right adjacent to the specific SC-FDMA symbols, wherein the ACK/NACK control signals overwrite some of

the multiplexed signals mapped to the 2-dimensional resource matrix at step (b) from the last row of the specific columns; and

(d) transmitting the signals mapped to the 2-dimensional resource matrix at steps (b) and (c) by column by column to a base station. ~~subcarriers corresponding to symbols near the symbol on which the reference signal is mapped.~~

10. (Previously presented) The method of claim 9, wherein the first control signals comprise at least one of:

precoding matrix index (PMI) signals; or  
channel quality indicator (CQI) signals.

11. (Cancelled)

12. (Currently amended) The method of claim 9, wherein one subframe comprises two slots, wherein the specific SC-FDMA symbols correspond to ~~reference signal is mapped to~~ at least one subcarrier corresponding to a fourth SC-FDMA symbol ~~symbols~~ out of seven SC-FDMA symbols in each [[a]] slot.

13. (Cancelled)

14. (Currently amended) The method of claim 9, wherein the ACK/NACK control signals are transmitted via ~~mapped to~~ subcarriers corresponding to [[a]] third SC-FDMA symbols ~~symbol~~ and [[a]] fifth SC-FDMA symbols ~~symbol~~ out of seven SC-FDMA symbols in each [[a]] slot.



15. (Previously presented) The method of claim 9, wherein the ACK/NACK control signals are channel coded independently of the data signals or first control signals.

16. (Currently amended) The method of claim 9, wherein the step (d) comprises further comprising:

~~respectively performing for each of the plurality of symbols having mapped multiplexed signals or mapped ACK/NACK control signals, a discrete Fourier transform (DFT) for the signals mapped to each column of the 2-dimensional resource matrix signals on signals mapped on subcarriers corresponding to the same symbol on the time-frequency resource map;~~

~~respectively performing an inverse fast Fourier transform (IFFT) on the DFT-transformed signals corresponding to the signals mapped to each column of the 2-dimensional resource matrix signals; mapped on subcarriers corresponding to the same symbol on the time-frequency resource map;~~

~~respectively attaching a cyclic prefix to the IFFT-transformed signals corresponding to the signals mapped to each column of the 2-dimensional resource matrix signals; and mapped on subcarriers corresponding to the same symbol on the time-frequency resource map; and~~

~~transmitting the cyclic prefix attached signals to the base station each symbol having IFFT-transformed signals with an attached cyclic prefix as a single carrier frequency division multiple access (SC-FDMA) symbol.~~

17. (Currently Amended) The method of claim 9, wherein the signals mapped to the 2-dimensional resource matrix are transmitted further comprising transmitting the signals mapped to the time-frequency resource map through a physical uplink shared channel (PUSCH).

18-26. (Cancelled)

27. (Currently amended) A mobile station for transmitting uplink signals comprising control signals and data signals in a wireless communication system, the mobile station comprising:

a processor serially multiplexing first control signals and data signals, wherein the first control signals are placed at a front part of the multiplexed signals and the data signals are placed at a rear part of the multiplexed signals;

the processor ~~sequentially~~ mapping the multiplexed signals to a 2-dimensional resource matrix comprising a plurality of columns and a plurality of rows, wherein the columns and the rows of the 2-dimensional resource matrix correspond to single carrier frequency divisional multiple access (SC-FDMA) and subcarriers for each SC-FDMA symbol, respectively, wherein a number of columns of the 2-dimensional resource matrix corresponds to a number of SC-FDMA symbols within one subframe except specific SC\_FDMA symbols used for a reference signal, and wherein the multiplexed signals are mapped from the first column of the first row to the last column of the first row, the first column of the second row to the last column of the second row, and so on, until all the multiplexed signals are mapped to the 2-dimensional resource matrix~~time-frequency resource map according to a time-first mapping method, wherein the time-frequency resource map comprises a plurality of symbols and a plurality of subcarriers for each symbol, and a reference signal is mapped to at least one subcarrier corresponding to one of the plurality of symbols;~~ and

the processor mapping ACK/NACK control signals to specific columns of the 2-dimensional resource matrix, wherein the specific columns correspond to SC-FDMA symbols

right adjacent to the specific SC-FDMA symbols, wherein the ACK/NACK control signals overwrite some of the multiplexed signals mapped to the 2-dimensional resource matrix from the last row of the specific columns subcarriers corresponding to symbols near the symbol on which the reference signal is mapped.

28. (Previously presented) The mobile station of claim 27, wherein the first control signals comprise at least one of:

precoding matrix index (PMI) signals; or  
channel quality indicator (CQI) signals.

29. (Cancelled)

30. (Currently amended) The mobile station of claim 27, wherein one subframe comprises two slots, wherein the specific SC-FDMA symbols correspond to reference signal is mapped to at least one subcarrier corresponding to a fourth SC-FDMA symbol ~~symbol~~ out of seven SC-FDMA symbols in each ~~[[a]]~~ slot.

31. (Cancelled)

32. (Currently amended) The mobile station of claim 27, wherein the ACK/NACK control signals are transmitted via mapped to ~~mapped to~~ subcarriers corresponding to ~~[[a]]~~ third SC-FDMA symbols ~~symbol~~ and ~~[[a]]~~ fifth SC-FDMA symbols ~~symbol~~ out of seven SC-FDMA symbols in each ~~[[a]]~~ slot.

33. (Previously presented) The mobile station of claim 27, wherein the ACK/NACK control signals are channel coded independently of the data signals or first control signals.

34. (Currently amended) The mobile station of claim 27, wherein the processor further adapted for comprising:

~~the processor respectively performing for each of the plurality of symbols having mapped multiplexed signals or mapped ACK/NACK control signals, a discrete Fourier transform (DFT) the signals mapped to each column of the 2-dimensional resource matrix signals on signals mapped on subcarriers corresponding to the same symbol on the time-frequency resource map;~~

~~the processor respectively performing an inverse fast Fourier transform (IFFT) on the DFT-transformed signals corresponding to the signals mapped to each column of the 2-dimensional resource matrix signals mapped on subcarriers corresponding to the same symbol on the time-frequency resource map;~~

~~the processor respectively attaching a cyclic prefix to the IFFT-transformed signals corresponding to the signals mapped to each column of the 2-dimensional resource matrix signals mapped on subcarriers corresponding to the same symbol on the time-frequency resource map; and~~

~~the processor transmitting the cyclic prefix attached signals to a base station each symbol having IFFT-transformed signals with an attached cyclic prefix as a single carrier frequency division multiple access (SC-FDMA) symbol.~~

35. (Currently amended) The mobile station of claim 27, wherein the signals mapped to the 2-dimensional resource matrix are transmitted ~~further comprising the processor~~

~~transmitting the signals mapped to the time-frequency resource map~~ through a physical uplink shared channel (PUSCH).

36-44. (Cancelled)

### **REMARKS**

Claims 9, 10, 12, 14-17, 27, 28, 30, 32-35 are currently pending in the application, claims 1-8 having previously been canceled, and claims 11, 13, 18-26, 29, 31, and 36-44 being currently cancelled without prejudice or disclaimer. Claims 1 and 27 are the only independent claims. No new matter has been added as the foregoing amendments have support in the specification as originally filed. For example, support for various amendments may be found at least in, for example, Figs. 3-9 and accompanying portions of the specification.

Claims 9, 18, 21, 27 and 36 are rejected under 35 U.S.C. 112, second paragraph, as being indefinite for failing to particularly point out and distinctly claim the subject matter which applicant regards as the invention. Claims 9-14, 16-17, 27-32, 34, and 35 are rejected under 35 U.S.C. 102(e) as being anticipated by Papasakellariou et al. (U.S. Publication No. 2008/0304467). Claims 15, 18, 20-26, 33, 36, and 38-44 are rejected under 35 U.S.C. 103(a) as being unpatentable over Papasakellariou, in view of Seo et al. (U.S. Publication No. 2003/0185159). Claims 19 and 27 are rejected under 35 U.S.C. 103(a) as being unpatentable over Papasakellariou, in view of Seo and further in view of Oh et al. (U.S. Publication No. 2006/0098568). Applicant respectfully traverses these rejections, and requests reconsideration and allowance of the pending claims in view of the following arguments.

#### **Rejection – 35 U.S.C. § 112**

Claims 9, 18, 21, 27 and 36 were rejected under 35 U.S.C. 112, second paragraph, as being indefinite for failing to particularly point out and distinctively claim the subject matter which applicant regards as the invention. Particularly, the Examiner rejected the term “near” in claims 9, 18, 21, 27 and 36. By this amendment, claims 18, 21 and 36 are cancelled, and the term “near” is replaced by the term “right adjacent to” in claims 9 and 27.

Therefore, withdrawal of this rejection is respectfully requested.

#### **Rejection – 35 U.S.C. § 102**

Claims 9-14, 16, 17, 27-32, 34 and 35 were rejected under 35 U.S.C. 102(e) as being anticipated by Papasakellariou et al (US Pub No. 2008/0304467 A1).

Claim 9, as amended, recites “serially multiplexing first control signals and data signals in a mobile station, wherein the first control signals are placed at a front part of the multiplexed

signals and the data signals are placed at a rear part of the multiplexed signals” And claim 9 recites “wherein the multiplexed signals are mapped from the first column of the first row to the last column of the first row, the first column of the second row to the last column of the second row, and so on, until all the multiplexed signals are mapped to the 2-dimensional resource matrix””

It is respectfully submitted that Papasakellariou fails to teach or suggest about ‘this sequence of first control signals and data signals within the multiplexed signals’ and ‘sequence of mapping the multiplexed signals to the 2-dimensional resource matrix’.

FIGs. 2 and 3 of show Papasakellariou “multiplex data bits and CQI bits”. However, Papasakellariou does not teach anything about the sequence of data bit and CQI bits within the multiplexed signals, and neither ‘sequence of mapping the multiplexed signals to the 2-dimensional resource matrix’. Even though Papasakellariou simply mentions that the resource for transmitting multiplexed signals is 2-dimentional, Papasakellariou does not teach the mapping scheme in view of this 2-dimensional resource matrix.

Further, claim 9, as amended, recites “wherein the ACK/NACK control signals overwrite some of the multiplexed signals mapped to the 2-dimensional resource matrix at step (b) from the last row of the specific columns”. By making the ACK/NACK control signals overwrite some of the multiplexed signals from the last row of the specific column while the multiplexed signals has the sequence of the first control signals and data signals, and mapped to the 2-dimensional resource matrix as stated above, claim 9 can reduce the probability that the first control signals are overwritten by the ACK/NACK signals.

It is respectfully submitted that Papasakellariou fails to teach this feature. As stated above, Papasakellariou does not teach the mapping scheme in view of 2-dimensional resource matrix, and also Papasakellariou fails to suggest any evidence for the overwriting feature. Therefore, Papasakellariou fails to teach at least the identified features of claim 9 and this claim is believed to be patentable. Claim 27 includes similar features and is believed to be patentable as well.

### **Rejection – 35 U.S.C. § 103**

Claims 15, 18, 20-26, 33, 36 and 38-44 were rejected under 35 U.S.C. 103(a) as being unpatentable over Papasakellariou et al (US Pub No. 2008/0304467 A1) in view of Seo et al (US Pub No. 2003/0185159 A1). Claims 19 and 37 were rejected under 35 U.S.C. 103(a) as being

unpatentable over Papasakellariou et al (US Pub No. 2008/0304467 A1) in view of Seo et al (US Pub No. 2003/0185159 A1) and further in view of Oh et al (US Pub. No. 2006/0098568 A1). However, since neither Seo nor Oh cure the above deficiencies of Papasakellariou, dependent claims depending from claims 9 or 27 are also patentable over the cited references.

### CONCLUSION

In view of the above remarks, Applicant submits that the currently pending claims of the present application are in condition for allowance. Reexamination and reconsideration of the application is requested.

No amendment made was related to the statutory requirements of patentability unless expressly stated herein; and no amendment made was for the purpose of narrowing the scope of any claim, unless Applicant has argued herein that such amendment was made to distinguish over a particular reference or combination of references.

If for any reason the Examiner finds the application other than in condition for allowance, the Examiner is requested to call the undersigned attorney at the Los Angeles, California telephone number (213) 623-2221 to discuss the steps necessary for placing the application in condition for allowance.

Respectfully submitted,

Lee, Hong, Degerman, Kang & Waimey

Date: September 6, 2011

By:           /Jeffrey Lotspeich/            
Jeffrey J. Lotspeich  
Registration No. 45,737  
Attorney for Applicant

Customer No. 035884



## Electronic Acknowledgement Receipt

<b>EFS ID:</b>	10887940
<b>Application Number:</b>	12209136
<b>International Application Number:</b>	
<b>Confirmation Number:</b>	3897
<b>Title of Invention:</b>	METHOD FOR TRANSMITTING UPLINK SIGNALS
<b>First Named Inventor/Applicant Name:</b>	Dae Won Lee
<b>Customer Number:</b>	35884
<b>Filer:</b>	Jeffrey John Lotspeich/Nicolette Silva
<b>Filer Authorized By:</b>	Jeffrey John Lotspeich
<b>Attorney Docket Number:</b>	2101-3573
<b>Receipt Date:</b>	06-SEP-2011
<b>Filing Date:</b>	11-SEP-2008
<b>Time Stamp:</b>	19:15:08
<b>Application Type:</b>	Utility under 35 USC 111(a)

### Payment information:

Submitted with Payment	no
------------------------	----

### File Listing:

Document Number	Document Description	File Name	File Size(Bytes)/ Message Digest	Multi Part /.zip	Pages (if appl.)
1	Miscellaneous Incoming Letter	1_2101-3573_Transmittal_of_A mendment.pdf	449710 e11e4d99b47ad0b28a558d65f68c47ba871 3fcf6	no	1

### Warnings:

### Information:

2		2_2101-3573_ROA.pdf	518508 36e1c20c402910ee3d4c0edd61d5d8b92c00cd1a	yes	11
<b>Multipart Description/PDF files in .zip description</b>					
<b>Document Description</b>		<b>Start</b>	<b>End</b>		
Amendment/Req. Reconsideration-After Non-Final Reject		1	1		
Claims		2	8		
Applicant Arguments/Remarks Made in an Amendment		9	11		
<b>Warnings:</b>					
<b>Information:</b>					
<b>Total Files Size (in bytes):</b>			968218		
<p><b>This Acknowledgement Receipt evidences receipt on the noted date by the USPTO of the indicated documents, characterized by the applicant, and including page counts, where applicable. It serves as evidence of receipt similar to a Post Card, as described in MPEP 503.</b></p> <p><b><u>New Applications Under 35 U.S.C. 111</u></b>  <b>If a new application is being filed and the application includes the necessary components for a filing date (see 37 CFR 1.53(b)-(d) and MPEP 506), a Filing Receipt (37 CFR 1.54) will be issued in due course and the date shown on this Acknowledgement Receipt will establish the filing date of the application.</b></p> <p><b><u>National Stage of an International Application under 35 U.S.C. 371</u></b>  <b>If a timely submission to enter the national stage of an international application is compliant with the conditions of 35 U.S.C. 371 and other applicable requirements a Form PCT/DO/EO/903 indicating acceptance of the application as a national stage submission under 35 U.S.C. 371 will be issued in addition to the Filing Receipt, in due course.</b></p> <p><b><u>New International Application Filed with the USPTO as a Receiving Office</u></b>  <b>If a new international application is being filed and the international application includes the necessary components for an international filing date (see PCT Article 11 and MPEP 1810), a Notification of the International Application Number and of the International Filing Date (Form PCT/RO/105) will be issued in due course, subject to prescriptions concerning national security, and the date shown on this Acknowledgement Receipt will establish the international filing date of the application.</b></p>					

Customer No. 035884

Attorney Docket No.: 2101-3573

## IN THE UNITED STATES PATENT AND TRADEMARK OFFICE

In re application of:  
Dae Won Lee

Art Unit: 2463

Serial No: 12/209,136  
Filed: September 11, 2008  
For: METHOD FOR TRANSMITTING UPLINK  
SIGNALS

Examiner: Mang Hang Yeung

Conf. No.: 3897

Mail Stop Amendment  
Commissioner for Patents  
P.O. Box 1450  
Alexandria, VA 22313-1450

Sir:  
Transmitted herewith is an AMENDMENT in the above-identified application.

- A petition for extension of time for \_ month(s) is enclosed.  
 No additional fee is required.

The fee has been calculated as shown below:

	(Col. 1) CLAIMS REMAINING AFTER AMENDMENT		(Col. 2) HIGHEST NUMBER PREVIOUSLY PAID FOR	(Col. 3) PRESENT EXTRA*	LG/SM \$ ENTITY FEE	ADD'L FEE DUE
TOTAL CLAIMS FEE	14	-	36	**	0	LG=\$52 SM=\$26 \$ 0
INDEPENDENT CLAIMS FEE	2	-	4	***	0	LG=\$220 SM=\$110 \$ 0
FIRST PRESENTATION OF MULTIPLE DEPENDENT CLAIMS					LARGE ENTITY FEE = \$390 SMALL ENTITY FEE = \$195	\$ 0
<b>TOTAL</b>						<b>\$ 0</b>

\* If the entry in Col. 1 is less than the entry in Col. 2, write "0" in Col. 3.

\*\* If the "Highest Number Previously Paid For" IN THIS SPACE is less than 20, write "20" in this space.

\*\*\* If the "Highest Number Previously Paid For" IN THIS SPACE is less than 3, write "3" in this space. The "Highest Number Previously Paid For" (Total or Independent) is the highest number found from the equivalent box on Col. 1 of a prior amendment or the number of claims originally filed.

- The Commissioner is hereby authorized to charge payment of the following fees associated with this communication or credit any overpayment to **Deposit Account No. 502290**:
- Excess claim(s) fee in the amount of \$\_\_\_\_\_.
- RCE fee in the amount of \$\_\_\_\_\_.
- Extension fees in the amount of \$\_\_\_\_\_.
- Petition fee in the amount of \$\_\_\_\_\_.
- Terminal Disclaimer fee in the amount of \$\_\_\_\_\_.
- Any filing fees under 37 CFR 1.16 for the presentation of extra claims.
- Any patent application processing fees under 37 CFR 1.17.

Respectfully submitted,  
Lee, Hong, Degerman, Kang & Waimey

Date: September 6, 2011

By:           /Jeffrey Lotspeich/            
Jeffrey J. Lotspeich  
Registration No. 45,737  
Attorney for Applicant(s)

Under the Paperwork Reduction Act of 1995, no persons are required to respond to a collection of information unless it displays a valid OMB control number.

<b>PATENT APPLICATION FEE DETERMINATION RECORD</b> Substitute for Form PTO-875					Application or Docket Number <b>12/209,136</b>		Filing Date <b>09/11/2008</b>		<input type="checkbox"/> To be Mailed			
<b>APPLICATION AS FILED – PART I</b>							<b>OTHER THAN</b>					
(Column 1)			(Column 2)		SMALL ENTITY <input type="checkbox"/>		OR		SMALL ENTITY			
FOR		NUMBER FILED	NUMBER EXTRA		RATE (\$)	FEE (\$)	OR		RATE (\$)	FEE (\$)		
<input type="checkbox"/> BASIC FEE <small>(37 CFR 1.16(a), (b), or (c))</small>		N/A	N/A		N/A				N/A			
<input type="checkbox"/> SEARCH FEE <small>(37 CFR 1.16(k), (j), or (m))</small>		N/A	N/A		N/A				N/A			
<input type="checkbox"/> EXAMINATION FEE <small>(37 CFR 1.16(o), (p), or (q))</small>		N/A	N/A		N/A				N/A			
TOTAL CLAIMS <small>(37 CFR 1.16(j))</small>		minus 20 =	*		X \$ =		OR		X \$ =			
INDEPENDENT CLAIMS <small>(37 CFR 1.16(h))</small>		minus 3 =	*		X \$ =				X \$ =			
<input type="checkbox"/> APPLICATION SIZE FEE <small>(37 CFR 1.16(s))</small>		If the specification and drawings exceed 100 sheets of paper, the application size fee due is \$250 (\$125 for small entity) for each additional 50 sheets or fraction thereof. See 35 U.S.C. 41(a)(1)(G) and 37 CFR 1.16(s).										
<input type="checkbox"/> MULTIPLE DEPENDENT CLAIM PRESENT <small>(37 CFR 1.16(j))</small>												
* If the difference in column 1 is less than zero, enter "0" in column 2.												
<b>APPLICATION AS AMENDED – PART II</b>					<b>OTHER THAN</b>							
(Column 1)			(Column 2)		SMALL ENTITY			OR		SMALL ENTITY		
AMENDMENT	<b>09/06/2011</b>		CLAIMS REMAINING AFTER AMENDMENT		HIGHEST NUMBER PREVIOUSLY PAID FOR	PRESENT EXTRA	RATE (\$)	ADDITIONAL FEE (\$)	OR		RATE (\$)	ADDITIONAL FEE (\$)
	<small>Total (37 CFR 1.16(i))</small>		* 14	Minus	** 36	= 0	X \$ =		OR		X \$52=	0
	<small>Independent (37 CFR 1.16(h))</small>		* 4	Minus	***4	= 0	X \$ =		OR		X \$220=	0
	<input type="checkbox"/> Application Size Fee <small>(37 CFR 1.16(s))</small>											
	<input type="checkbox"/> FIRST PRESENTATION OF MULTIPLE DEPENDENT CLAIM <small>(37 CFR 1.16(j))</small>											
							TOTAL ADD'L FEE		OR		TOTAL ADD'L FEE	<b>0</b>
(Column 1)			(Column 2)		SMALL ENTITY			OR		SMALL ENTITY		
AMENDMENT			CLAIMS REMAINING AFTER AMENDMENT		HIGHEST NUMBER PREVIOUSLY PAID FOR	PRESENT EXTRA	RATE (\$)	ADDITIONAL FEE (\$)	OR		RATE (\$)	ADDITIONAL FEE (\$)
	<small>Total (37 CFR 1.16(i))</small>		*	Minus	**	=	X \$ =		OR		X \$ =	
	<small>Independent (37 CFR 1.16(h))</small>		*	Minus	***	=	X \$ =		OR		X \$ =	
	<input type="checkbox"/> Application Size Fee <small>(37 CFR 1.16(s))</small>											
	<input type="checkbox"/> FIRST PRESENTATION OF MULTIPLE DEPENDENT CLAIM <small>(37 CFR 1.16(j))</small>											
							TOTAL ADD'L FEE		OR		TOTAL ADD'L FEE	

\* If the entry in column 1 is less than the entry in column 2, write "0" in column 3.  
 \*\* If the "Highest Number Previously Paid For" IN THIS SPACE is less than 20, enter "20".  
 \*\*\* If the "Highest Number Previously Paid For" IN THIS SPACE is less than 3, enter "3".

The "Highest Number Previously Paid For" (Total or Independent) is the highest number found in the appropriate box in column 1.

Legal Instrument Examiner:  
/MINNIE JACKSON/

This collection of information is required by 37 CFR 1.16. The information is required to obtain or retain a benefit by the public which is to file (and by the USPTO to process) an application. Confidentiality is governed by 35 U.S.C. 122 and 37 CFR 1.14. This collection is estimated to take 12 minutes to complete, including gathering, preparing, and submitting the completed application form to the USPTO. Time will vary depending upon the individual case. Any comments on the amount of time you require to complete this form and/or suggestions for reducing this burden, should be sent to the Chief Information Officer, U.S. Patent and Trademark Office, U.S. Department of Commerce, P.O. Box 1450, Alexandria, VA 22313-1450. DO NOT SEND FEES OR COMPLETED FORMS TO THIS ADDRESS. **SEND TO: Commissioner for Patents, P.O. Box 1450, Alexandria, VA 22313-1450.**

If you need assistance in completing the form, call 1-800-PTO-9199 and select option 2.



## UNITED STATES PATENT AND TRADEMARK OFFICE

UNITED STATES DEPARTMENT OF COMMERCE  
 United States Patent and Trademark Office  
 Address: COMMISSIONER FOR PATENTS  
 P.O. Box 1450  
 Alexandria, Virginia 22313-1450  
 www.uspto.gov

APPLICATION NO.	FILING DATE	FIRST NAMED INVENTOR	ATTORNEY DOCKET NO.	CONFIRMATION NO.
12/209,136	09/11/2008	Dae Won Lee	2101-3573	3897
35884	7590	06/24/2011	EXAMINER	
LEE, HONG, DEGERMAN, KANG & WAIMEY 660 S. FIGUEROA STREET Suite 2300 LOS ANGELES, CA 90017			YEUNG, MANG HANG	
			ART UNIT	PAPER NUMBER
			2463	
			NOTIFICATION DATE	DELIVERY MODE
			06/24/2011	ELECTRONIC

**Please find below and/or attached an Office communication concerning this application or proceeding.**

The time period for reply, if any, is set in the attached communication.

Notice of the Office communication was sent electronically on above-indicated "Notification Date" to the following e-mail address(es):

uspto@hlaw.com  
 ip.hlaw@gmail.com  
 ip.hlaw@live.com

<b>Office Action Summary</b>	<b>Application No.</b>	<b>Applicant(s)</b>	
	12/209,136	LEE ET AL.	
	<b>Examiner</b>	<b>Art Unit</b>	
	MANG YEUNG	2463	

-- The MAILING DATE of this communication appears on the cover sheet with the correspondence address --

### Period for Reply

A SHORTENED STATUTORY PERIOD FOR REPLY IS SET TO EXPIRE 3 MONTH(S) OR THIRTY (30) DAYS, WHICHEVER IS LONGER, FROM THE MAILING DATE OF THIS COMMUNICATION.

- Extensions of time may be available under the provisions of 37 CFR 1.136(a). In no event, however, may a reply be timely filed after SIX (6) MONTHS from the mailing date of this communication.
- If NO period for reply is specified above, the maximum statutory period will apply and will expire SIX (6) MONTHS from the mailing date of this communication.
- Failure to reply within the set or extended period for reply will, by statute, cause the application to become ABANDONED (35 U.S.C. § 133). Any reply received by the Office later than three months after the mailing date of this communication, even if timely filed, may reduce any earned patent term adjustment. See 37 CFR 1.704(b).

### Status

- 1)  Responsive to communication(s) filed on 11 September 2008.
- 2a)  This action is **FINAL**.                      2b)  This action is non-final.
- 3)  Since this application is in condition for allowance except for formal matters, prosecution as to the merits is closed in accordance with the practice under *Ex parte Quayle*, 1935 C.D. 11, 453 O.G. 213.

### Disposition of Claims

- 4)  Claim(s) 9-44 is/are pending in the application.
- 4a) Of the above claim(s) \_\_\_\_\_ is/are withdrawn from consideration.
- 5)  Claim(s) \_\_\_\_\_ is/are allowed.
- 6)  Claim(s) 9-44 is/are rejected.
- 7)  Claim(s) \_\_\_\_\_ is/are objected to.
- 8)  Claim(s) \_\_\_\_\_ are subject to restriction and/or election requirement.

### Application Papers

- 9)  The specification is objected to by the Examiner.
- 10)  The drawing(s) filed on 11 September 2008 is/are: a)  accepted or b)  objected to by the Examiner.  
Applicant may not request that any objection to the drawing(s) be held in abeyance. See 37 CFR 1.85(a).  
Replacement drawing sheet(s) including the correction is required if the drawing(s) is objected to. See 37 CFR 1.121(d).
- 11)  The oath or declaration is objected to by the Examiner. Note the attached Office Action or form PTO-152.

### Priority under 35 U.S.C. § 119

- 12)  Acknowledgment is made of a claim for foreign priority under 35 U.S.C. § 119(a)-(d) or (f).
- a)  All    b)  Some \*    c)  None of:
1.  Certified copies of the priority documents have been received.
2.  Certified copies of the priority documents have been received in Application No. \_\_\_\_\_.
3.  Copies of the certified copies of the priority documents have been received in this National Stage application from the International Bureau (PCT Rule 17.2(a)).

\* See the attached detailed Office action for a list of the certified copies not received.

### Attachment(s)

- |   |   |
|---|---|
| 1) <input checked="" type="checkbox"/> Notice of References Cited (PTO-892)   | 4) <input type="checkbox"/> Interview Summary (PTO-413)<br>Paper No(s)/Mail Date. _____ |
| 2) <input type="checkbox"/> Notice of Draftperson's Patent Drawing Review (PTO-948)                                   | 5) <input type="checkbox"/> Notice of Informal Patent Application                       |
| 3) <input checked="" type="checkbox"/> Information Disclosure Statement(s) (PTO/SB/08)<br>Paper No(s)/Mail Date _____ | 6) <input type="checkbox"/> Other: _____  |

Application/Control Number: 12/209,136  
Art Unit: 2463

Page 2

### **DETAILED ACTION**

1. This Office Action is in response to the application **12/209136** filed on **09/11/2008**.
2. **Claims 1 - 8** have been cancelled. **New claims 9 - 44** have been added. Pending claims include **claims 9 – 44**.

### **Priority**

3. As required by M.P.E.P. 201.14(c), acknowledgement is made of applicant's claim for priority based on an application filed on **07/15/2008 (KOREA 10-2008-0068634)**. Receipt is acknowledged of papers submitted under 35 U.S.C. 119(a)-(d), which papers have been placed of record in the file.

### **Claim Rejections - 35 USC § 112**

4. The following is a quotation of the second paragraph of 35 U.S.C. 112:  
  
The specification shall conclude with one or more claims particularly pointing out and distinctly claiming the subject matter which the applicant regards as his invention.

**Claims 9, 18, 21, 27 and 36** are rejected under 35 U.S.C. 112, second paragraph, as being indefinite for failing to particularly point out and distinctly claim the subject matter which applicant regards as the invention.

The term "**near**" in claim 9 (line 10) is a relative term which renders the claim indefinite. The term "**near**" is not defined by the claim, the specification does not

Application/Control Number: 12/209,136

Page 3

Art Unit: 2463

provide a standard for ascertaining the requisite degree, and one of ordinary skill in the art would not be reasonably apprised of the scope of the invention.

Regarding **claims 18, 21, 27 and 36** (see rejection of claim 9).

**Claim Rejections - 35 USC § 102**

5. The following is a quotation of the appropriate paragraphs of 35 U.S.C. 102 that form the basis for the rejections under this section made in this Office action:

A person shall be entitled to a patent unless –

(e) the invention was described in (1) an application for patent, published under section 122(b), by another filed in the United States before the invention by the applicant for patent or (2) a patent granted on an application for patent by another filed in the United States before the invention by the applicant for patent, except that an international application filed under the treaty defined in section 351(a) shall have the effects for purposes of this subsection of an application filed in the United States only if the international application designated the United States and was published under Article 21(2) of such treaty in the English language.

6. **Claims 9 – 14, 16, 17, 27 – 32, 34, and 35** are rejected under 35 U.S.C. 102(e) as being anticipated by Papasakellariou et al. (US Patent Publication # 2008/0304467 A1).

As per **claim 9**, Papasakellariou discloses “**A method for transmitting uplink signals comprising control signals and data signals in a wireless communication system, the method comprising:**” as [(fig. 10)] “**serially multiplexing first control signals and data signals in a mobile station;**” [(fig. 10), CQI and DATA. (fig. 2), MULTIPLEX DATA BITS AND CQI BITS 220 ] “**sequentially mapping the multiplexed signals to a time-frequency resource map according to a time-first mapping method,**” [(fig. 10)] “**wherein the time-frequency resource map comprises a**



Application/Control Number: 12/209,136

Page 4

Art Unit: 2463

**plurality of symbols and a plurality of subcarriers for each symbol,”** [(fig. 1 and par. 0007 – 0008), each resource block contains 12 sub-carriers] **“and a reference signal is mapped to at least one subcarrier corresponding to one of the plurality of symbols;”** [(fig. 1 and par. 0007 – 0008), An exemplary embodiment assumes that each reference signal includes 12 sub-carriers] **“and mapping ACK/NACK control signals to subcarriers corresponding to symbols near the symbol on which the reference signal is mapped”** [(fig. 10 and par. 0049), the location of the ACK/NAK bits 1010 remains in symbols next to the RS 1030].

As per **claim 10**, Papasakellariou discloses **“The method of claim 9,”** as [see rejection of claim 9] **“wherein the first control signals comprise at least one of: precoding matrix index (PMI) signals; or channel quality indicator (CQI) signals”** [(fig. 10), CQI and DATA].

As per **claim 11**, Papasakellariou discloses **“The method of claim 9,”** as [see rejection of claim 9] **“wherein the ACK/NACK control signals are mapped to the subcarriers by overwriting the first control signals or data signals mapped to the subcarriers corresponding to symbols near the symbol on which the reference signal is mapped”** [(fig. 10 and par. 0049), the location of the ACK/NAK bits 1010 remains in symbols next to the RS 1030].

Application/Control Number: 12/209,136  
Art Unit: 2463

Page 5

As per **claim 12**, Papasakellariou discloses “**The method of claim 9,**” as [see rejection of claim 9] “**wherein the reference signal is mapped to at least one subcarrier corresponding to a fourth symbol out of seven symbols in a slot**” as [(fig. 10), RS 1030].

As per **claim 13**, Cheng discloses “**The method of claim 9,**” as [see rejection of claim 9] “**wherein the ACK/NACK control signals are mapped to subcarriers corresponding to symbols on either side of the symbol on which the reference signal is mapped**” [(fig. 10), RS 1030 and ACK/NAK bits 1010].

As per **claim 14**, Papasakellariou discloses “**The method of claim 9,**” as [see rejection of claim 9] “**wherein the ACK/NACK control signals are mapped to subcarriers corresponding to a third symbol and a fifth symbol out of seven symbols in a slot**” [(fig. 10), RS 1030 and ACK/NAK bits 1010].

As per **claim 16**, Papasakellariou discloses “**The method of claim 9,**” as [see rejection of claim 9] “**further comprising: respectively performing for each of the plurality of symbols having mapped multiplexed signals or mapped ACK/NACK control signals, a discrete Fourier transform (DFT) on signals mapped on subcarriers corresponding to the same symbol on the time-frequency resource map;**” [(fig. 2 and par. 0009), DFT 240] “**respectively performing an inverse fast Fourier transform (IFFT) on the DFT- transformed signals mapped on subcarriers**

Application/Control Number: 12/209,136

Page 6

Art Unit: 2463

**corresponding to the same symbol on the time-frequency resource map;” [(fig. 2 and par. 0009), DFT 240 and IFFT 270] “respectively attaching a cyclic prefix to the IFFT-transformed signals mapped on subcarriers corresponding to the same symbol on the time-frequency resource map;” [(fig. 2 and par. 0009), DFT 240 and IFFT 270 and CP INSECTION 270] “and transmitting each symbol having IFFT-transformed signals with an attached cyclic prefix as a single carrier frequency division multiple access (SC-FDMA) symbol” [(fig. 2 and par. 0009), TRANSMITTED SIGNAL 290].**

As per **claim 17**, Papasakellariou discloses “**The method of claim 9,**” as [see rejection of claim 9] “**further comprising transmitting the signals mapped to the time-frequency resource map through a physical uplink shared channel (PUSCH)**” [(fig. 2 and par. 0009), TRANSMITTED SIGNAL 290].

As per **claim 27**, [see rejection of claim 9].

As per **claim 28**, [see rejection of claim 10].

As per **claim 29**, [see rejection of claim 11].

As per **claim 30**, [see rejection of claim 12].

As per **claim 31**, [see rejection of claim 13].

As per **claim 32**, [see rejection of claim 14].

As per **claim 34**, [see rejection of claim 16].

As per **claim 35**, [see rejection of claim 17].

Application/Control Number: 12/209,136  
Art Unit: 2463

Page 7

**Claim Rejections - 35 USC § 103**

7. The following is a quotation of 35 U.S.C. 103(a) which forms the basis for all obviousness rejections set forth in this Office action:

(a) A patent may not be obtained though the invention is not identically disclosed or described as set forth in section 102 of this title, if the differences between the subject matter sought to be patented and the prior art are such that the subject matter as a whole would have been obvious at the time the invention was made to a person having ordinary skill in the art to which said subject matter pertains. Patentability shall not be negated by the manner in which the invention was made.

8. **Claims 15, 18, 20 – 26, 33, 36, and 38 – 44** are rejected under 35 U.S.C. 103(a) as being unpatentable over Papasakellariou et al. (US Patent Publication # 2008/0304467 A1) in view of Seo et al. (US Patent Publication # 2003/0185159 A1).

As per **claim 15**, Papasakellariou discloses “**The method of claim 9,**” as [see rejection of claim 9].

Papasakellariou does not explicitly disclose “wherein the ACK/NACK control signals are channel coded independently of the data signals or first control signals”.

However, Seo discloses “**wherein the ACK/NACK control signals are channel coded independently of the data signals or first control signals**” as [(Fig. 15 and pars. 0122 – 0123), encoder 1532, encoder 1525 and encoder 1524].

Papasakellariou et al. (US Patent Publication # 2008/0304467 A1) and Seo et al. (US Patent Publication # 2003/0185159 A1) are analogous art because they are the same field of endeavor of network communication.

It would have been obvious to one of ordinary skill in the art at the time of the invention to incorporate Seo’s teaching into Papasakellariou’s teaching. The motivation

Application/Control Number: 12/209,136

Page 8

Art Unit: 2463

for making the above modification would be to increase the likelihood for a mobile station to correctly perform channel estimation. (See, par. 0033)

As per **claim 18**, Papasakellariou discloses **“A method for transmitting uplink signals comprising first control signals, ACK/NACK control signals and data signals in a wireless communication system, the method comprising:”** as [(fig. 10)] **“serially multiplexing the channel coded first control signals and the channel coded data signals;”** [(fig. 10), CQI and DATA. (fig. 2), MULTIPLEX DATA BITS AND CQI BITS 220 ] **“sequentially mapping the multiplexed signals to a time-frequency resource map according to a time-first mapping method,”** [(fig. 10)] **“wherein the time-frequency resource map comprises a plurality of symbols and a plurality of subcarriers for each symbol,”** [(fig. 1 and par. 0007 – 0008), each resource block contains 12 sub-carriers] **“and a reference signal is mapped to at least one subcarrier corresponding to one of the plurality of symbols;”** [(fig. 1 and par. 0007 – 0008), An exemplary embodiment assumes that each reference signal includes 12 sub-carriers] **“and mapping the channel coded ACK/NACK control signals to subcarriers corresponding to symbols near the symbol on which the reference signal is mapped”** [(fig. 10 and par. 0049), the location of the ACK/NAK bits 1010 remains in symbols next to the RS 1030].

Papasakellariou does not explicitly disclose “channel coding in a mobile station each of the first control signals, the ACK/NACK control signals, and the data signals,

Application/Control Number: 12/209,136

Page 9

Art Unit: 2463

wherein the first control signals, the ACK/NACK control signals and the data signals are independently channel coded from each other”.

However, Seo discloses “**channel coding in a mobile station each of the first control signals, the ACK/NACK control signals, and the data signals, wherein the first control signals, the ACK/NACK control signals and the data signals are independently channel coded from each other**” as [(Fig. 15 and pars. 0122 – 0123), encoder 1532, encoder 1525 and encoder 1524].

Papasakellariou et al. (US Patent Publication # 2008/0304467 A1) and Seo et al. (US Patent Publication # 2003/0185159 A1) are analogous art because they are the same field of endeavor of network communication.

It would have been obvious to one of ordinary skill in the art at the time of the invention to incorporate Seo’s teaching into Papasakellariou’s teaching. The motivation for making the above modification would be to increase the likelihood for a mobile station to correctly perform channel estimation. (Seo, par. 0033)

As per **claim 20**, Papasakellariou in view of Seo discloses “**The method of claim 18,**” as [see rejection of claim 18].

Papasakellariou discloses “**wherein the first control signals comprise at least one of: precoding matrix index (PMI) signals; or channel quality indicator (CQI) signals**” [(fig. 10), CQI and DATA].

Application/Control Number: 12/209,136  
Art Unit: 2463

Page 10

As per **claim 21**, Papasakellariou in view of Seo discloses “**The method of claim 18,**” as [see rejection of claim 18].

Papasakellariou discloses “**wherein the channel coded ACK/NACK control signals are mapped to the subcarriers by overwriting the channel coded first control signals or channel coded data signals mapped to the subcarriers corresponding to symbols near the symbol on which the reference signal is mapped**” [(fig. 10 and par. 0049), the location of the ACK/NAK bits 1010 remains in symbols next to the RS 1030].

As per **claim 22**, Papasakellariou in view of Seo discloses “**The method of claim 18,**” as [see rejection of claim 18].

Papasakellariou discloses “**wherein the reference signal is mapped to at least one subcarrier corresponding to a fourth symbol out of seven symbols in a slot**” as [(fig. 10), RS 1030].

As per **claim 23**, Papasakellariou in view of Seo discloses “**The method of claim 18,**” as [see rejection of claim 18].

Papasakellariou discloses “**wherein the channel coded ACK/NACK control signals are mapped to subcarriers corresponding to symbols on either side of the symbol on which the reference signal is mapped**” as [(fig. 10), RS 1030 and ACK/NAK bits 1010].

Application/Control Number: 12/209,136  
Art Unit: 2463

Page 11

As per **claim 24**, Papasakellariou in view of Seo discloses **“The method of claim 18,”** as [see rejection of claim 18].

Papasakellariou discloses **“wherein the ACK/NACK control signals are mapped to subcarriers corresponding to a third symbol and a fifth symbol out of seven symbols in a slot”** as [(fig. 10), RS 1030 and ACK/NAK bits 1010].

As per **claim 25**, Papasakellariou in view of Seo discloses **“The method of claim 18,”** as [see rejection of claim 18].

Papasakellariou discloses **“further comprising: respectively performing for each of the plurality of symbols having mapped multiplexed signals or mapped ACK/NACK control signals, a discrete Fourier transform (DFT) on signals mapped on subcarriers corresponding to the same symbol on the time-frequency resource map;”** as [(fig. 2 and par. 0009), DFT 240] **“respectively performing an inverse fast Fourier transform (IFFT) on the DFT-transformed signals mapped on subcarriers corresponding to the same symbol on the time-frequency resource map;”** [(fig. 2 and par. 0009), DFT 240 and IFFT 270] **“respectively attaching a cyclic prefix to the IFFT-transformed signals mapped on subcarriers corresponding to the same symbol on the time-frequency resource map;”** [(fig. 2 and par. 0009), DFT 240 and IFFT 270 and CP INSECTION 270] **“and transmitting each symbol having IFFT-transformed signals with an attached cyclic prefix as a single carrier frequency division multiple access (SC-FDMA) symbol”** [(fig. 2 and par. 0009),



Application/Control Number: 12/209,136  
Art Unit: 2463

Page 12

TRANSMITTED SIGNAL 290].

As per **claim 26**, Papasakellariou in view of Seo discloses “**The method of claim 18,**” as [see rejection of claim 18].

Papasakellariou discloses “**further comprising transmitting the signals mapped to the time-frequency resource map through a physical uplink shared channel (PUSCH)**” as [(fig. 2 and par. 0009), TRANSMITTED SIGNAL 290].

As per **claim 33**, [see rejection of claim 15].

As per **claim 36**, [see rejection of claim 18].

As per **claim 38**, [see rejection of claim 20].

As per **claim 39**, [see rejection of claim 21].

As per **claim 40**, [see rejection of claim 22].

As per **claim 41**, [see rejection of claim 23].

As per **claim 42**, [see rejection of claim 24].

As per **claim 43**, [see rejection of claim 25].

As per **claim 44**, [see rejection of claim 26].

9. **Claims 19 and 37** are rejected under 35 U.S.C. 103(a) as being unpatentable over Papasakellariou et al. (US Patent Publication # 2003/0304467 A1) in view of Seo et al. (US Patent Publication # 2003/0185159 A1) and further in view of Oh et al. (US Patent Publication # 2006/0098568 A1).

Application/Control Number: 12/209,136  
Art Unit: 2463

Page 13

As per **claim 19**, Papasakellariou in view of Seo discloses “**The method of claim 18,**” as [see rejection of claim 18].

Oh discloses “**wherein channel coding the data signals comprises: attaching a transport block cyclic redundancy check (CRC) to a transport block for transmitting the data signals; segmenting the transport block having the attached transport block CRC into at least one code block unit; attaching a code block CRC to the at least one segmented code block; performing channel coding on the data attached with the code block CRC; and performing rate matching and code block concatenation one the channel coded data**” as [(fig. 1), Data with CRC 101 and Encoder 102].

Papasakellariou et al. (US Patent Publication # 2008/0304467 A1) and Oh et al. (US Patent Publication # 2006/0098568 A1) are analogous art because they are the same field of endeavor of network communication.

It would have been obvious to one of ordinary skill in the art at the time of the invention to incorporate Oh’s teaching into Papasakellariou’s teaching. The motivation for making the above modification would be to reduce fading and distortion of the amplitude and phase of the received signals in a high speed wireless data communication environments. (Oh, par. 0001 to par. 0010)

As per **claim 37**, [see rejection of claim 19].

Application/Control Number: 12/209,136  
Art Unit: 2463

Page 14

**Conclusion**

Any inquiry concerning this communication or earlier communications from the examiner should be directed to MANG YEUNG whose telephone number is (571)270-7319. The examiner can normally be reached on Mon to Th (9:00am to 5:00pm EST).

If attempts to reach the examiner by telephone are unsuccessful, the examiner's supervisor, Derrick W. Ferris can be reached on 571 272 3123. The fax phone number for the organization where this application or proceeding is assigned is 571-273-8300.

Information regarding the status of an application may be obtained from the Patent Application Information Retrieval (PAIR) system. Status information for published applications may be obtained from either Private PAIR or Public PAIR. Status information for unpublished applications is available through Private PAIR only. For more information about the PAIR system, see <http://pair-direct.uspto.gov>. Should you have questions on access to the Private PAIR system, contact the Electronic Business Center (EBC) at 866-217-9197 (toll-free). If you would like assistance from a USPTO Customer Service Representative or access to the automated information system, call 800-786-9199 (IN USA OR CANADA) or 571-272-1000.

/M.Y./

/Derrick W Ferris/

Supervisory Patent Examiner, Art Unit 2463

<b>Notice of References Cited</b>	Application/Control No. 12/209,136	Applicant(s)/Patent Under Reexamination LEE ET AL.	
	Examiner MANG YEUNG	Art Unit 2463	Page 1 of 1

**U.S. PATENT DOCUMENTS**

*	Document Number Country Code-Number-Kind Code	Date MM-YYYY	Name	Classification
*	A US-2003/0185159 A1	10-2003	Seo et al.	370/278
*	B US-2006/0098568 A1	05-2006	Oh et al.	370/206
*	C US-2008/0304467 A1	12-2008	Papasakellariou et al.	370/344
	D US-			
	E US-			
	F US-			
	G US-			
	H US-			
	I US-			
	J US-			
	K US-			
	L US-			
	M US-			

**FOREIGN PATENT DOCUMENTS**

*	Document Number Country Code-Number-Kind Code	Date MM-YYYY	Country	Name	Classification
	N				
	O				
	P				
	Q				
	R				
	S				
	T				

**NON-PATENT DOCUMENTS**

*	Document Number Country Code-Number-Kind Code	Date MM-YYYY	Country	Name	Classification
	Include as applicable: Author, Title Date, Publisher, Edition or Volume, Pertinent Pages)				
	U				
	V				
	W				
	X				

\*A copy of this reference is not being furnished with this Office action. (See MPEP § 707.05(a).)  
Dates in MM-YYYY format are publication dates. Classifications may be US or foreign.

<b>Search Notes</b>  	<b>Application/Control No.</b>  12209136	<b>Applicant(s)/Patent Under Reexamination</b>  LEE ET AL.
	<b>Examiner</b>  MANG YEUNG	<b>Art Unit</b>  2463

**SEARCHED**

Class	Subclass	Date	Examiner
370	206,278,344	6/15/2011	/M.Y./

**SEARCH NOTES**

Search Notes	Date	Examiner
370/206,278,344 with limited text searching (see EAST Search History)	6/15/2011	/M.Y./
Inventor search (Palm)	6/15/2011	/M.Y./

**INTERFERENCE SEARCH**

Class	Subclass	Date	Examiner

/MANG YEUNG/ Examiner.Art Unit 2463	
--	--

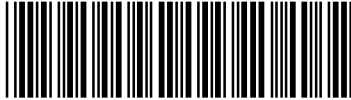
<b><i>Index of Claims</i></b>  	<b>Application/Control No.</b> 12209136	<b>Applicant(s)/Patent Under Reexamination</b> LEE ET AL.
	<b>Examiner</b> MANG YEUNG	<b>Art Unit</b> 2463

✓	<b>Rejected</b>
=	<b>Allowed</b>

-	<b>Cancelled</b>
÷	<b>Restricted</b>

N	<b>Non-Elected</b>
I	<b>Interference</b>

A	<b>Appeal</b>
O	<b>Objected</b>

Claims renumbered in the same order as presented by applicant
  CPA
  T.D.
  R.1.47

CLAIM		DATE							
Final	Original	06/15/2011							
	1	-							
	2	-							
	3	-							
	4	-							
	5	-							
	6	-							
	7	-							
	8	-							
	9	✓							
	10	✓							
	11	✓							
	12	✓							
	13	✓							
	14	✓							
	15	✓							
	16	✓							
	17	✓							
	18	✓							
	19	✓							
	20	✓							
	21	✓							
	22	✓							
	23	✓							
	24	✓							
	25	✓							
	26	✓							
	27	✓							
	28	✓							
	29	✓							
	30	✓							
	31	✓							
	32	✓							
	33	✓							
	34	✓							
	35	✓							
	36	✓							

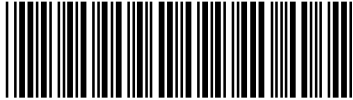
<b><i>Index of Claims</i></b>  	<b>Application/Control No.</b>  12209136	<b>Applicant(s)/Patent Under Reexamination</b>  LEE ET AL.
	<b>Examiner</b>  MANG YEUNG	<b>Art Unit</b>  2463

✓	<b>Rejected</b>
=	<b>Allowed</b>

-	<b>Cancelled</b>
÷	<b>Restricted</b>

N	<b>Non-Elected</b>
I	<b>Interference</b>

A	<b>Appeal</b>
O	<b>Objected</b>

Claims renumbered in the same order as presented by applicant
  CPA
  T.D.
  R.1.47

CLAIM		DATE							
Final	Original	06/15/2011							
	37	✓							
	38	✓							
	39	✓							
	40	✓							
	41	✓							
	42	✓							
	43	✓							
	44	✓							



UNITED STATES PATENT AND TRADEMARK OFFICE

UNITED STATES DEPARTMENT OF COMMERCE  
 United States Patent and Trademark Office  
 Address: COMMISSIONER FOR PATENTS  
 P.O. Box 1450  
 Alexandria, Virginia 22313-1450  
 www.uspto.gov

BIB DATA SHEET

CONFIRMATION NO. 3897

<b>SERIAL NUMBER</b> 12/209,136	<b>FILING or 371(c) DATE</b> 09/11/2008 <b>RULE</b>	<b>CLASS</b> 370	<b>GROUP ART UNIT</b> 2463	<b>ATTORNEY DOCKET NO.</b> 2101-3573	
<b>APPLICANTS</b> Dae Won Lee, Gyeonggi-do, KOREA, REPUBLIC OF; Bong Hoe Kim, Gyeonggi-do, KOREA, REPUBLIC OF; Young Woo Yun, Gyeonggi-do, KOREA, REPUBLIC OF; Ki Jun Kim, Gyeonggi-do, KOREA, REPUBLIC OF; Dong Wook Roh, Gyeonggi-do, KOREA, REPUBLIC OF; Hak Seong Kim, Gyeonggi-do, KOREA, REPUBLIC OF; Hyun Wook Park, Gyeonggi-do, KOREA, REPUBLIC OF;					
<b>** CONTINUING DATA *****</b> This appln claims benefit of 60/972,244 09/13/2007 and claims benefit of 60/987,427 11/13/2007 and claims benefit of 60/988,433 11/16/2007					
<b>** FOREIGN APPLICATIONS *****</b> REPUBLIC OF KOREA 10-2008-0068634 07/15/2008					
<b>** IF REQUIRED, FOREIGN FILING LICENSE GRANTED **</b> 09/24/2008					
Foreign Priority claimed <input checked="" type="checkbox"/> Yes <input type="checkbox"/> No 35 USC 119(a-d) conditions met <input checked="" type="checkbox"/> Yes <input type="checkbox"/> No Verified and Acknowledged <u>/MANG YEUNG/</u> Examiner's Signature	<input type="checkbox"/> Met after Allowance <u>/M.Y./</u> Initials	<b>STATE OR COUNTRY</b> KOREA, REPUBLIC OF	<b>SHEETS DRAWINGS</b> 9	<b>TOTAL CLAIMS</b> 8	<b>INDEPENDENT CLAIMS</b> 2
<b>ADDRESS</b> LEE, HONG, DEGERMAN, KANG & WAIMEY 660 S. FIGUEROA STREET Suite 2300 LOS ANGELES, CA 90017 UNITED STATES					
<b>TITLE</b> METHOD FOR TRANSMITTING UPLINK SIGNALS					
<b>FILING FEE RECEIVED</b> 2582	FEES: Authority has been given in Paper No. _____ to charge/credit DEPOSIT ACCOUNT No. _____ for following:			<input type="checkbox"/> All Fees <input type="checkbox"/> 1.16 Fees (Filing) <input type="checkbox"/> 1.17 Fees (Processing Ext. of time) <input type="checkbox"/> 1.18 Fees (Issue) <input type="checkbox"/> Other _____ <input type="checkbox"/> Credit	



## EAST Search History

## EAST Search History (Prior Art)

Ref #	Hits	Search Query	DBs	Default Operator	Plurals	Time Stamp
L1	94	(channel near cod\$3) same (CQI PMI) same (ack acknowledg\$5 nack)	US-PGPUB; USPAT; EPO; JPO; DERWENT	OR	ON	2011/06/15 12:59
L2	334	((channel near cod\$3) encod\$3) same (CQI PMI) same (ack acknowledg\$5 nack)	US-PGPUB; USPAT; EPO; JPO; DERWENT	OR	ON	2011/06/15 13:03
L3	217	L2 and ("370".clas. "455". clas.)	US-PGPUB; USPAT; EPO; JPO; DERWENT	OR	ON	2011/06/15 13:03
L4	454	((channel near cod\$3) encod\$3 CRC (cyclic adj2 check\$3)) same (CQI PMI) same (ack acknowledg\$5 nack)	US-PGPUB; USPAT; EPO; JPO; DERWENT	OR	ON	2011/06/15 13:27
L5	313	L4 and ("370".clas. "455". clas.)	US-PGPUB; USPAT; EPO; JPO; DERWENT	OR	ON	2011/06/15 13:27
L6	158	(CRC (cyclic adj2 check \$3)) same (CQI PMI) same (ack acknowledg\$5 nack)	US-PGPUB; USPAT; EPO; JPO; DERWENT	OR	ON	2011/06/15 13:28
L7	126	L6 and ("370".clas. "455". clas.)	US-PGPUB; USPAT; EPO; JPO; DERWENT	OR	ON	2011/06/15 13:28
L8	268	( encod\$3 ) same (CQI PMI) same (ack acknowledg\$5 nack)	US-PGPUB; USPAT; EPO; JPO; DERWENT	OR	ON	2011/06/15 14:00
L9	167	L8 and ("370".clas. "455". clas.)	US-PGPUB; USPAT; EPO; JPO; DERWENT	OR	ON	2011/06/15 14:01
L10	3	"20060098568"	US-PGPUB; USPAT; EPO; JPO; DERWENT	OR	ON	2011/06/15 15:08
L12	280	(ack acknowledg\$5 nack) same (CQI PMI) same reference same (carrier\$1 sub\$1channel subchannel channel sub\$1carrier\$1 subcarrier tone\$1)	US-PGPUB; USPAT; EPO; JPO; DERWENT	OR	ON	2011/06/15 15:20
L13	14	L12 and (370/206,278,344. ccls.)	US-PGPUB; USPAT; EPO; JPO; DERWENT	OR	ON	2011/06/15 15:20

S1	1	"12209136"	US-PGPUB; USPAT; EPO; JPO; DERWENT	OR	ON	2011/06/13 10:52
S2	2	"20090097466"	US-PGPUB; USPAT; EPO; JPO; DERWENT	OR	ON	2011/06/13 10:52
S3	2	US-20050232138-\$.DID. OR US-20050286402-\$. DID. OR KR-20051206-\$. DID. OR KR-20040701-\$. DID.	US-PGPUB; USPAT; USOCR	OR	ON	2011/06/13 10:54
S4	6	US-1569403-\$.DID. OR EP- 20050831-\$.DID. OR US- 1806867-\$.DID. OR EP- 20070711-\$.DID. OR US- 1811701-\$.DID. OR EP- 20070725-\$.DID.	US-PGPUB; USPAT; USOCR	OR	ON	2011/06/13 10:54
S5	1524	symbol\$1 same (ack nack acknowledg\$5 respon\$5) same (subcarrier\$1 sub \$1carrier\$1 carrier tons) same ofdm	US-PGPUB; USPAT; EPO; JPO; DERWENT	OR	ON	2011/06/13 11:10
S6	163	symbol\$1 same (ack nack acknowledg\$5 respon\$5) same (subcarrier\$1 sub \$1carrier\$1 carrier tons) same reference same ofdm	US-PGPUB; USPAT; EPO; JPO; DERWENT	OR	ON	2011/06/13 11:11
S7	38	symbol\$1 same (ack nack acknowledg\$5) same (subcarrier\$1 sub\$1carrier \$1 carrier tons) same reference same ofdm	US-PGPUB; USPAT; EPO; JPO; DERWENT	OR	ON	2011/06/13 11:16
S8	152	symbol\$1 same (ack nack acknowledg\$5) same (subcarrier\$1 sub\$1carrier \$1 carrier tons) same ofdm	US-PGPUB; USPAT; EPO; JPO; DERWENT	OR	ON	2011/06/13 11:16
S9	109	symbol\$1 same (ack nack acknowledg\$5) same (subcarrier\$1 sub\$1carrier \$1 carrier tons) same (frame subframe sub \$1frame\$1) and ofdm	US-PGPUB; USPAT; EPO; JPO; DERWENT	OR	ON	2011/06/13 11:17
S10	5559	((cyclic near2 check) CRC) same (ack acknowledg\$5 nack)	US-PGPUB; USPAT; EPO; JPO; DERWENT	OR	ON	2011/06/14 09:36
S11	1555	((cyclic near2 check) CRC) same (ack acknowledg\$5 nack) same (subcarrier\$1 sub\$1carrier\$1 channel\$1 subchannel\$1 sub \$1channel\$1 tone\$1)	US-PGPUB; USPAT; EPO; JPO; DERWENT	OR	ON	2011/06/14 09:40

S12	33	((cyclic near2 check) CRC) same (ack acknowledg\$5 nack) same (subcarrier\$1 sub\$1carrier\$1 channel\$1 subchannel\$1 sub\$1channel\$1 tone\$1) same ofdm	US-PGPUB; USPAT; EPO; JPO; DERWENT	OR	ON	2011/06/14 09:40
S13	47	((cyclic near2 check) CRC) same (ack acknowledg\$5 nack) same (subcarrier\$1 sub\$1carrier\$1 channel\$1 subchannel\$1 sub\$1channel\$1 tone\$1) same (ofdm fdma)	US-PGPUB; USPAT; EPO; JPO; DERWENT	OR	ON	2011/06/14 09:40
S14	675	((cyclic near2 check) CRC) same (ack acknowledg\$5 nack) same (subcarrier\$1 sub\$1carrier\$1 channel\$1 subchannel\$1 sub\$1channel\$1 tone\$1) same (cod\$3)	US-PGPUB; USPAT; EPO; JPO; DERWENT	OR	ON	2011/06/14 09:42
S15	106	((time\$1first (time adj first)) near2 map\$4)	US-PGPUB; USPAT; EPO; JPO; DERWENT	OR	ON	2011/06/14 10:16
S16	10	((time\$1first (time adj first)) near2 map\$4) same (ack nack acknowledg\$5)	US-PGPUB; USPAT; EPO; JPO; DERWENT	OR	ON	2011/06/14 10:16
S17	106	((time\$1first (time adj first)) near2 map\$4)	US-PGPUB; USPAT; EPO; JPO; DERWENT	OR	ON	2011/06/14 10:21
S18	106	((time\$1first (time adj first)) near2 map\$4)	US-PGPUB; USPAT; EPO; JPO; DERWENT	OR	ON	2011/06/14 10:22
S21	1171	MIMO and (ARQ HARQ) and (ack acknowledg\$5 nack) same (carrier\$1 sub\$1channel subchannel channel sub\$1carrier\$1 subcarrier tone\$1)	US-PGPUB; USPAT; EPO; JPO; DERWENT	OR	ON	2011/06/14 10:44
S22	754	MIMO and (ARQ HARQ) same (ack acknowledg\$5 nack) same (carrier\$1 sub\$1channel subchannel channel sub\$1carrier\$1 subcarrier tone\$1)	US-PGPUB; USPAT; EPO; JPO; DERWENT	OR	ON	2011/06/14 10:44
S23	754	MIMO and ((ARQ HARQ) same (ack acknowledg\$5 nack) same (carrier\$1 sub\$1channel subchannel channel sub\$1carrier\$1 subcarrier tone\$1))	US-PGPUB; USPAT; EPO; JPO; DERWENT	OR	ON	2011/06/14 10:45

S24	120	MIMO and ((ARQ HARQ) same (ack acknowledg\$5 nack) same (carrier\$1 sub\$1channel subchannel channel sub\$1carrier\$1 subcarrier tone\$1)) same symbol\$1	US-PGPUB; USPAT; EPO; JPO; DERWENT	OR	ON	2011/06/14 10:45
S25	2058	(CQI same (ack acknowledg\$5 nack))	US-PGPUB; USPAT; EPO; JPO; DERWENT	OR	ON	2011/06/14 12:23
S26	1851	CQI same (ack acknowledg\$5 nack) same (carrier\$1 sub\$1channel subchannel channel sub\$1carrier\$1 subcarrier tone\$1)	US-PGPUB; USPAT; EPO; JPO; DERWENT	OR	ON	2011/06/14 12:23
S27	1222	CQI same (ack acknowledg\$5 nack) same (carrier\$1 sub\$1channel subchannel channel sub\$1carrier\$1 subcarrier tone\$1) same (symbol\$1 data)	US-PGPUB; USPAT; EPO; JPO; DERWENT	OR	ON	2011/06/14 12:24
S28	263	CQI same (ack acknowledg\$5 nack) same (carrier\$1 sub\$1channel subchannel channel sub\$1carrier\$1 subcarrier tone\$1) same (symbol\$1 data) same mobile	US-PGPUB; USPAT; EPO; JPO; DERWENT	OR	ON	2011/06/14 12:25
S29	637	CQI same (ack acknowledg\$5 nack) same (carrier\$1 sub\$1channel subchannel channel sub\$1carrier\$1 subcarrier tone\$1) same (symbol\$1 data) same (mobile UE (user adj equipment))	US-PGPUB; USPAT; EPO; JPO; DERWENT	OR	ON	2011/06/14 12:26
S30	550	S29 and ("370".clas. "455". clas.)	US-PGPUB; USPAT; EPO; JPO; DERWENT	OR	ON	2011/06/14 12:26
S31	407	CQI same (ack acknowledg\$5 nack) same (carrier\$1 sub\$1channel subchannel channel sub\$1carrier\$1 subcarrier tone\$1) same (symbol\$1 data) and MIMO	US-PGPUB; USPAT; EPO; JPO; DERWENT	OR	ON	2011/06/14 12:38
S32	329	S31 and ("370".clas. "455". clas.)	US-PGPUB; USPAT; EPO; JPO; DERWENT	OR	ON	2011/06/14 12:38

S33	81	CQI same (acknowledg\$5 nack) same (carrier\$1 sub\$1channel subchannel channel sub\$1carrier\$1 subcarrier tone\$1) same (symbol\$1 data) same mobile and MIMO	US-PGPUB; USPAT; EPO; JPO; DERWENT	OR	ON	2011/06/14 12:38
S35	263	(PMI CQI) same (acknowledg\$5 nack) same (carrier\$1 sub\$1channel subchannel channel sub\$1carrier\$1 subcarrier tone\$1) same (symbol\$1 data) same mobile	US-PGPUB; USPAT; EPO; JPO; DERWENT	OR	ON	2011/06/14 13:51
S36	224	S35 and ("370".clas. "455". clas.)	US-PGPUB; USPAT; EPO; JPO; DERWENT	OR	ON	2011/06/14 13:51
S37	4531	SC\$1FDMA	US-PGPUB; USPAT; EPO; JPO; DERWENT	OR	ON	2011/06/14 14:32
S38	153	SC\$1FDMA same (acknowledg\$5 nack)	US-PGPUB; USPAT; EPO; JPO; DERWENT	OR	ON	2011/06/14 14:33
S39	65	SC\$1FDMA same (acknowledg\$5 nack) same (CQI PMI)	US-PGPUB; USPAT; EPO; JPO; DERWENT	OR	ON	2011/06/14 14:34
S40	595	SC\$1FDMA and (acknowledg\$5 nack) same (CQI PMI)	US-PGPUB; USPAT; EPO; JPO; DERWENT	OR	ON	2011/06/14 14:34
S41	494	S40 and ("370".clas. "455". clas.)	US-PGPUB; USPAT; EPO; JPO; DERWENT	OR	ON	2011/06/14 14:34
S42	557	SC\$1FDMA and (acknowledg\$5 nack) same (CQI PMI) same (carrier\$1 sub\$1channel subchannel channel sub\$1carrier\$1 subcarrier tone\$1)	US-PGPUB; USPAT; EPO; JPO; DERWENT	OR	ON	2011/06/14 14:34
S43	471	S42 and ("370".clas. "455". clas.)	US-PGPUB; USPAT; EPO; JPO; DERWENT	OR	ON	2011/06/14 14:35
S44	120	SC\$1FDMA and (acknowledg\$5 nack) same (CQI PMI) same symbol\$1 same (carrier\$1 sub\$1channel subchannel channel sub\$1carrier\$1 subcarrier tone\$1)	US-PGPUB; USPAT; EPO; JPO; DERWENT	OR	ON	2011/06/14 14:35

S45	145	SC\$1FDMA and (ack acknowledg\$5 nack) same (CQI PMI) same reference same (carrier\$1 sub \$1channel subchannel channel sub\$1carrier\$1 subcarrier tone\$1)	US-PGPUB; USPAT; EPO; JPO; DERWENT	OR	ON	2011/06/14 14:52
S46	18	SC\$1FDMA same (ack acknowledg\$5 nack) same (CQI PMI) same reference same (carrier\$1 sub \$1channel subchannel channel sub\$1carrier\$1 subcarrier tone\$1)	US-PGPUB; USPAT; EPO; JPO; DERWENT	OR	ON	2011/06/14 15:14
S47	21	SC\$1FDMA same (ack acknowledg\$5 nack) same (CQI PMI) same reference	US-PGPUB; USPAT; EPO; JPO; DERWENT	OR	ON	2011/06/14 15:15
S48	81	(PMI CQI) same (ack acknowledg\$5 nack) same (carrier\$1 sub\$1channel subchannel channel sub \$1carrier\$1 subcarrier tone \$1) same (symbol\$1 data) same mobile and MIMO	US-PGPUB; USPAT; EPO; JPO; DERWENT	OR	ON	2011/06/15 09:15
S49	0	enhanced adj data adj "326"	US-PGPUB; USPAT; EPO; JPO; DERWENT	OR	ON	2011/06/15 09:16
S50	15	enhanced adj data same "326"	US-PGPUB; USPAT; EPO; JPO; DERWENT	OR	ON	2011/06/15 09:16
S51	170	SC\$1FDMA and (ack acknowledg\$5 nack) same (CQI PMI) same reference	US-PGPUB; USPAT; EPO; JPO; DERWENT	OR	ON	2011/06/15 09:20
S52	280	(ack acknowledged\$5 nack) same (CQI PMI) same reference same (carrier\$1 sub\$1channel subchannel channel sub\$1carrier\$1 subcarrier tone\$1)	US-PGPUB; USPAT; EPO; JPO; DERWENT	OR	ON	2011/06/15 10:24
S53	227	S52 and ("370".clas. "455". clas.)	US-PGPUB; USPAT; EPO; JPO; DERWENT	OR	ON	2011/06/15 10:24

**EAST Search History (Interference)**

&lt; This search history is empty &gt;

**6/ 15/ 2011 3:25:39 PM****C:\ Documents and Settings\ myeung\ My Documents\ EAST\ Workspaces\ 12209136\ 12209136.  
wsp**

Receipt date: 04/29/2011

12209136 - GAI: 2463

Doc code: IDS

Doc description: Information Disclosure Statement (IDS) Filed

Approved for use through 07/31/2012. OMB 0651-0031  
U.S. Patent and Trademark Office; U.S. DEPARTMENT OF COMMERCE

Under the Paperwork Reduction Act of 1995, no persons are required to respond to a collection of information unless it contains a valid OMB control number.

<b>INFORMATION DISCLOSURE STATEMENT BY APPLICANT</b> ( Not for submission under 37 CFR 1.99)	Application Number		12209136	
	Filing Date		2008-09-11	
	First Named Inventor	Dae Won Lee		
	Art Unit	2463		
	Examiner Name	YEUNG, MANG HANG		
	Attorney Docket Number	2101-3573		

U.S. PATENTS						Remove
Examiner Initial*	Cite No	Patent Number	Kind Code <sup>1</sup>	Issue Date	Name of Patentee or Applicant of cited Document	Pages, Columns, Lines where Relevant Passages or Relevant Figures Appear
	1					

If you wish to add additional U.S. Patent citation information please click the Add button.

Add

U.S. PATENT APPLICATION PUBLICATIONS						Remove
Examiner Initial*	Cite No	Publication Number	Kind Code <sup>1</sup>	Publication Date	Name of Patentee or Applicant of cited Document	Pages, Columns, Lines where Relevant Passages or Relevant Figures Appear
	1					

If you wish to add additional U.S. Published Application citation information please click the Add button.

Add

FOREIGN PATENT DOCUMENTS								Remove
Examiner Initial*	Cite No	Foreign Document Number <sup>3</sup>	Country Code <sup>2</sup> j	Kind Code <sup>4</sup>	Publication Date	Name of Patentee or Applicant of cited Document	Pages, Columns, Lines where Relevant Passages or Relevant Figures Appear	T <sup>5</sup>
	1	1569403	EP		2005-08-31	Samsung Electronics Co., Ltd.		<input type="checkbox"/>
	2	1806867	EP		2007-07-11	Samsung Electronics Co., Ltd.		<input type="checkbox"/>
	3	1811701	EP		2007-07-25	Samsung Electronics Co., Ltd.		<input type="checkbox"/>

<b>INFORMATION DISCLOSURE STATEMENT BY APPLICANT</b> ( Not for submission under 37 CFR 1.99)	Application Number		12209136	12209136 - GAU: 2463
	Filing Date		2008-09-11	
	First Named Inventor	Dae Won Lee		
	Art Unit	2463		
	Examiner Name	YEUNG, MANG HANG		
	Attorney Docket Number	2101-3573		

If you wish to add additional Foreign Patent Document citation information please click the Add button				<b>Add</b>
<b>NON-PATENT LITERATURE DOCUMENTS</b>				<b>Remove</b>
Examiner Initials*	Cite No	Include name of the author (in CAPITAL LETTERS), title of the article (when appropriate), title of the item (book, magazine, journal, serial, symposium, catalog, etc), date, pages(s), volume-issue number(s), publisher, city and/or country where published.	T <sup>5</sup>	
	1		<input type="checkbox"/>	
If you wish to add additional non-patent literature document citation information please click the Add button				
<b>EXAMINER SIGNATURE</b>				
Examiner Signature	/Mang Hang Yeung/		Date Considered	06/15/2011
*EXAMINER: Initial if reference considered, whether or not citation is in conformance with MPEP 609. Draw line through a citation if not in conformance and not considered. Include copy of this form with next communication to applicant.				
<sup>1</sup> See Kind Codes of USPTO Patent Documents at <a href="http://www.USPTO.GOV">www.USPTO.GOV</a> or MPEP 901.04. <sup>2</sup> Enter office that issued the document, by the two-letter code (WIPO Standard ST.3). <sup>3</sup> For Japanese patent documents, the indication of the year of the reign of the Emperor must precede the serial number of the patent document. <sup>4</sup> Kind of document by the appropriate symbols as indicated on the document under WIPO Standard ST.16 if possible. <sup>5</sup> Applicant is to place a check mark here if English language translation is attached.				



Receipt date: 05/05/2009

12209136 - GAI: 2463

Doc code: IDS

Doc description: Information Disclosure Statement (IDS) Filed

Approved for use through 11/30/2008. OMB 0651-0031

U.S. Patent and Trademark Office; U.S. DEPARTMENT OF COMMERCE

Under the Paperwork Reduction Act of 1995, no persons are required to respond to a collection of information unless it contains a valid OMB control number.

<b>INFORMATION DISCLOSURE STATEMENT BY APPLICANT</b> ( Not for submission under 37 CFR 1.99)	Application Number	12209136
	Filing Date	2008-09-11
	First Named Inventor	Dae Won Lee
	Art Unit	2617
	Examiner Name	
	Attorney Docket Number	2101-3573

U.S.PATENTS							Remove
Examiner Initial*	Cite No	Patent Number	Kind Code <sup>1</sup>	Issue Date	Name of Patentee or Applicant of cited Document	Pages,Columns,Lines where Relevant Passages or Relevant Figures Appear	
	1						

If you wish to add additional U.S. Patent citation information please click the Add button.

Add

U.S.PATENT APPLICATION PUBLICATIONS							Remove
Examiner Initial*	Cite No	Publication Number	Kind Code <sup>1</sup>	Publication Date	Name of Patentee or Applicant of cited Document	Pages,Columns,Lines where Relevant Passages or Relevant Figures Appear	
	1	20050232138		2005-10-20	Byun et al.		
	2	20050286402		2005-12-29	Byun et al.		

If you wish to add additional U.S. Published Application citation information please click the Add button.

Add

FOREIGN PATENT DOCUMENTS								Remove
Examiner Initial*	Cite No	Foreign Document Number <sup>3</sup>	Country Code <sup>2</sup> j	Kind Code <sup>4</sup>	Publication Date	Name of Patentee or Applicant of cited Document	Pages,Columns,Lines where Relevant Passages or Relevant Figures Appear	T <sup>5</sup>
	1	10-2005-0114569	KR		2005-12-06	Samsung		<input type="checkbox"/>
	2	10-2004-0056976	KR		2004-07-01	ETRI		<input type="checkbox"/>

<b>INFORMATION DISCLOSURE STATEMENT BY APPLICANT</b> ( Not for submission under 37 CFR 1.99)	Application Number		12209136	12209136 - GAU: 2463
	Filing Date		2008-09-11	
	First Named Inventor	Dae Won Lee		
	Art Unit		2617	
	Examiner Name			
	Attorney Docket Number		2101-3573	

If you wish to add additional Foreign Patent Document citation information please click the Add button				<b>Add</b>
<b>NON-PATENT LITERATURE DOCUMENTS</b>				<b>Remove</b>
Examiner Initials*	Cite No	Include name of the author (in CAPITAL LETTERS), title of the article (when appropriate), title of the item (book, magazine, journal, serial, symposium, catalog, etc), date, pages(s), volume-issue number(s), publisher, city and/or country where published.	T <sup>5</sup>	
	1		<input type="checkbox"/>	
If you wish to add additional non-patent literature document citation information please click the Add button				<b>Add</b>
<b>EXAMINER SIGNATURE</b>				
Examiner Signature	/Mang Hang Yeung/		Date Considered	06/15/2011
*EXAMINER: Initial if reference considered, whether or not citation is in conformance with MPEP 609. Draw line through a citation if not in conformance and not considered. Include copy of this form with next communication to applicant.				
<sup>1</sup> See Kind Codes of USPTO Patent Documents at <a href="http://www.USPTO.GOV">www.USPTO.GOV</a> or MPEP 901.04. <sup>2</sup> Enter office that issued the document, by the two-letter code (WIPO Standard ST.3). <sup>3</sup> For Japanese patent documents, the indication of the year of the reign of the Emperor must precede the serial number of the patent document. <sup>4</sup> Kind of document by the appropriate symbols as indicated on the document under WIPO Standard ST.16 if possible. <sup>5</sup> Applicant is to place a check mark here if English language translation is attached.				

Doc code: IDS

Doc description: Information Disclosure Statement (IDS) Filed

PTO/SB/08a (01-10)

Approved for use through 07/31/2012. OMB 0651-0031

U.S. Patent and Trademark Office; U.S. DEPARTMENT OF COMMERCE

Under the Paperwork Reduction Act of 1995, no persons are required to respond to a collection of information unless it contains a valid OMB control number.

<b>INFORMATION DISCLOSURE STATEMENT BY APPLICANT</b> ( Not for submission under 37 CFR 1.99)	Application Number		12209136	
	Filing Date		2008-09-11	
	First Named Inventor	Dae Won Lee		
	Art Unit	2463		
	Examiner Name	YEUNG, MANG HANG		
	Attorney Docket Number	2101-3573		

U.S.PATENTS						Remove
Examiner Initial*	Cite No	Patent Number	Kind Code <sup>1</sup>	Issue Date	Name of Patentee or Applicant of cited Document	Pages,Columns,Lines where Relevant Passages or Relevant Figures Appear
	1					

If you wish to add additional U.S. Patent citation information please click the Add button.

Add

U.S.PATENT APPLICATION PUBLICATIONS						Remove
Examiner Initial*	Cite No	Publication Number	Kind Code <sup>1</sup>	Publication Date	Name of Patentee or Applicant of cited Document	Pages,Columns,Lines where Relevant Passages or Relevant Figures Appear
	1					

If you wish to add additional U.S. Published Application citation information please click the Add button.

Add

FOREIGN PATENT DOCUMENTS								Remove
Examiner Initial*	Cite No	Foreign Document Number <sup>3</sup>	Country Code <sup>2</sup> j	Kind Code <sup>4</sup>	Publication Date	Name of Patentee or Applicant of cited Document	Pages,Columns,Lines where Relevant Passages or Relevant Figures Appear	T <sup>5</sup>
	1	1569403	EP		2005-08-31	Samsung Electronics Co., Ltd.		<input type="checkbox"/>
	2	1806867	EP		2007-07-11	Samsung Electronics Co., Ltd.		<input type="checkbox"/>
	3	1811701	EP		2007-07-25	Samsung Electronics Co., Ltd.		<input type="checkbox"/>

<b>INFORMATION DISCLOSURE STATEMENT BY APPLICANT</b> ( Not for submission under 37 CFR 1.99)	Application Number		12209136
	Filing Date		2008-09-11
	First Named Inventor	Dae Won Lee	
	Art Unit		2463
	Examiner Name	YEUNG, MANG HANG	
	Attorney Docket Number		2101-3573

If you wish to add additional Foreign Patent Document citation information please click the Add button **Add**

**NON-PATENT LITERATURE DOCUMENTS** **Remove**

Examiner Initials*	Cite No	Include name of the author (in CAPITAL LETTERS), title of the article (when appropriate), title of the item (book, magazine, journal, serial, symposium, catalog, etc), date, pages(s), volume-issue number(s), publisher, city and/or country where published.	T <sup>5</sup>
	1		<input type="checkbox"/>

If you wish to add additional non-patent literature document citation information please click the Add button **Add**

**EXAMINER SIGNATURE**

Examiner Signature		Date Considered	
--------------------	--	-----------------	--

\*EXAMINER: Initial if reference considered, whether or not citation is in conformance with MPEP 609. Draw line through a citation if not in conformance and not considered. Include copy of this form with next communication to applicant.

<sup>1</sup> See Kind Codes of USPTO Patent Documents at [www.USPTO.GOV](http://www.USPTO.GOV) or MPEP 901.04. <sup>2</sup> Enter office that issued the document, by the two-letter code (WIPO Standard ST.3). <sup>3</sup> For Japanese patent documents, the indication of the year of the reign of the Emperor must precede the serial number of the patent document. <sup>4</sup> Kind of document by the appropriate symbols as indicated on the document under WIPO Standard ST.16 if possible. <sup>5</sup> Applicant is to place a check mark here if English language translation is attached.

<b>INFORMATION DISCLOSURE STATEMENT BY APPLICANT</b> ( Not for submission under 37 CFR 1.99)	Application Number	12209136
	Filing Date	2008-09-11
	First Named Inventor	Dae Won Lee
	Art Unit	2463
	Examiner Name	YEUNG, MANG HANG
	Attorney Docket Number	2101-3573

**CERTIFICATION STATEMENT**

Please see 37 CFR 1.97 and 1.98 to make the appropriate selection(s):

That each item of information contained in the information disclosure statement was first cited in any communication from a foreign patent office in a counterpart foreign application not more than three months prior to the filing of the information disclosure statement. See 37 CFR 1.97(e)(1).

**OR**

That no item of information contained in the information disclosure statement was cited in a communication from a foreign patent office in a counterpart foreign application, and, to the knowledge of the person signing the certification after making reasonable inquiry, no item of information contained in the information disclosure statement was known to any individual designated in 37 CFR 1.56(c) more than three months prior to the filing of the information disclosure statement. See 37 CFR 1.97(e)(2).

See attached certification statement.

The fee set forth in 37 CFR 1.17 (p) has been submitted herewith.

A certification statement is not submitted herewith.

**SIGNATURE**

A signature of the applicant or representative is required in accordance with CFR 1.33, 10.18. Please see CFR 1.4(d) for the form of the signature.

Signature	/Rolando Gonzalez/	Date (YYYY-MM-DD)	2011-04-29
Name/Print	Rolando Gonzalez	Registration Number	63,191

This collection of information is required by 37 CFR 1.97 and 1.98. The information is required to obtain or retain a benefit by the public which is to file (and by the USPTO to process) an application. Confidentiality is governed by 35 U.S.C. 122 and 37 CFR 1.14. This collection is estimated to take 1 hour to complete, including gathering, preparing and submitting the completed application form to the USPTO. Time will vary depending upon the individual case. Any comments on the amount of time you require to complete this form and/or suggestions for reducing this burden, should be sent to the Chief Information Officer, U.S. Patent and Trademark Office, U.S. Department of Commerce, P.O. Box 1450, Alexandria, VA 22313-1450. **DO NOT SEND FEES OR COMPLETED FORMS TO THIS ADDRESS. SEND TO: Commissioner for Patents, P.O. Box 1450, Alexandria, VA 22313-1450.**

## Privacy Act Statement

The Privacy Act of 1974 (P.L. 93-579) requires that you be given certain information in connection with your submission of the attached form related to a patent application or patent. Accordingly, pursuant to the requirements of the Act, please be advised that: (1) the general authority for the collection of this information is 35 U.S.C. 2(b)(2); (2) furnishing of the information solicited is voluntary; and (3) the principal purpose for which the information is used by the U.S. Patent and Trademark Office is to process and/or examine your submission related to a patent application or patent. If you do not furnish the requested information, the U.S. Patent and Trademark Office may not be able to process and/or examine your submission, which may result in termination of proceedings or abandonment of the application or expiration of the patent.

The information provided by you in this form will be subject to the following routine uses:

1. The information on this form will be treated confidentially to the extent allowed under the Freedom of Information Act (5 U.S.C. 552) and the Privacy Act (5 U.S.C. 552a). Records from this system of records may be disclosed to the Department of Justice to determine whether the Freedom of Information Act requires disclosure of these records.
2. A record from this system of records may be disclosed, as a routine use, in the course of presenting evidence to a court, magistrate, or administrative tribunal, including disclosures to opposing counsel in the course of settlement negotiations.
3. A record in this system of records may be disclosed, as a routine use, to a Member of Congress submitting a request involving an individual, to whom the record pertains, when the individual has requested assistance from the Member with respect to the subject matter of the record.
4. A record in this system of records may be disclosed, as a routine use, to a contractor of the Agency having need for the information in order to perform a contract. Recipients of information shall be required to comply with the requirements of the Privacy Act of 1974, as amended, pursuant to 5 U.S.C. 552a(m).
5. A record related to an International Application filed under the Patent Cooperation Treaty in this system of records may be disclosed, as a routine use, to the International Bureau of the World Intellectual Property Organization, pursuant to the Patent Cooperation Treaty.
6. A record in this system of records may be disclosed, as a routine use, to another federal agency for purposes of National Security review (35 U.S.C. 181) and for review pursuant to the Atomic Energy Act (42 U.S.C. 218(c)).
7. A record from this system of records may be disclosed, as a routine use, to the Administrator, General Services, or his/her designee, during an inspection of records conducted by GSA as part of that agency's responsibility to recommend improvements in records management practices and programs, under authority of 44 U.S.C. 2904 and 2906. Such disclosure shall be made in accordance with the GSA regulations governing inspection of records for this purpose, and any other relevant (i.e., GSA or Commerce) directive. Such disclosure shall not be used to make determinations about individuals.
8. A record from this system of records may be disclosed, as a routine use, to the public after either publication of the application pursuant to 35 U.S.C. 122(b) or issuance of a patent pursuant to 35 U.S.C. 151. Further, a record may be disclosed, subject to the limitations of 37 CFR 1.14, as a routine use, to the public if the record was filed in an application which became abandoned or in which the proceedings were terminated and which application is referenced by either a published application, an application open to public inspections or an issued patent.
9. A record from this system of records may be disclosed, as a routine use, to a Federal, State, or local law enforcement agency, if the USPTO becomes aware of a violation or potential violation of law or regulation.



Europäisches Patentamt  
European Patent Office  
Office européen des brevets



(11) EP 1 569 403 A2

(12) EUROPEAN PATENT APPLICATION

(43) Date of publication:  
31.08.2005 Bulletin 2005/35

(51) Int Cl.7: H04L 27/26, H04L 1/00

(21) Application number: 05004374.4

(22) Date of filing: 28.02.2005

(84) Designated Contracting States:  
AT BE BG CH CY CZ DE DK EE ES FI FR GB GR  
HU IE IS IT LI LT LU MC NL PL PT RO SE SI SK TR  
Designated Extension States:  
AL BA HR LV MK YU

- Lee, Ju-Ho, Samsung Electronics Co., Ltd.  
Suwon-si, Gyeonggi-do (KR)
- Yu, Han Il, Samsung Electronics Co., Ltd.  
Suwon-si, Gyeonggi-do (KR)
- Oh, Hyun-Seok, Samsung Electronics Co., Ltd.  
Suwon-si, Gyeonggi-do (KR)
- Cho, Joon-Young,  
Samsung Electronics Co., Ltd.  
Suwon-si, Gyeonggi-do (KR)

(30) Priority: 27.02.2004 KR 2004013668

(71) Applicant: SAMSUNG ELECTRONICS CO., LTD.  
Gyeonggi-do (KR)

(72) Inventors:  
• Cho, Yun-Ok, Samsung Electronics Co., Ltd.  
Suwon-si, Gyeonggi-do (KR)

(74) Representative: Grünecker, Kinkeldey,  
Stockmair & Schwanhäusser Anwaltssozietät  
Maximilianstrasse 58  
80538 München (DE)

(54) Method and apparatus for transmitting channel quality information in a multicarrier communication system

(57) A method and apparatus for efficiently transmitting channel quality information in an OFDM communication system using dynamic channel allocation and adaptive modulation, and determining parameters required for time-division channel quality information transmission in an asynchronous CDMA communication system are provided. In the OFDM communication system in which a plurality of subcarriers are allocated to a plurality of UEs, the subcarriers are divided into a

plurality of subcarrier groups each having at least one subcarrier. Each of the UEs determines and transmits the channel quality information of each of the subcarrier groups according to predetermined transmission parameters at transmission time points that do not overlap with those of other UEs. A Node B dynamically allocates the subcarriers to the UEs and their corresponding modulation schemes according to the channel quality information.

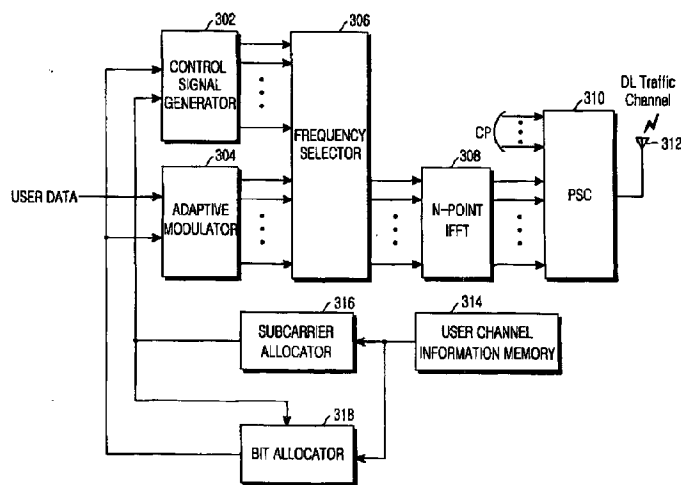

FIG.4

EP 1 569 403 A2

## EP 1 569 403 A2

**Description****BACKGROUND OF THE INVENTION**5 1. Field of the Invention

[0001] The present invention relates to a mobile communication system, and in particular, to a method of efficiently transmitting channel quality information in an OFDM (Orthogonal Frequency Division Multiplexing) communication system using dynamic channel allocation and adaptive modulation and a method of determining parameters required for time-division channel information transmission in an asynchronous CDMA (Code Division Multiple Access) communication system.

10 2. Description of the Related Art

15 [0002] OFDM is a multicarrier modulation scheme in which the entire frequency band is divided into multiple subcarriers and channel information is created and transmitted on a subcarrier basis, thereby lengthening the transmission period of the channel quality information. Because of its resistance to ISI (Inter-Symbol Interference) and its ability to implement difficult high-speed systems, OFDM has attracted more and more interest.

20 [0003] The OFDM system adopts dynamic channel allocation and adaptive modulation to allow multiple access from multiple users. The dynamic channel allocation and adaptive modulation is a technique that appropriately allocates subcarriers to the users through radio channel scheduling based on channel quality information from the users. In addition, the highest-order modulation scheme that satisfies a predetermined error rate for each subcarrier is determined.

25 [0004] Since the channel characteristics of UEs (User Equipments) using the same subcarriers are independent in the OFDM system, all subcarriers can be efficiently used except where every UE experiences deep fading. Therefore, the dynamic channel allocation and adaptive modulation significantly improve the performance of the OFDM system.

30 [0005] FIG 1 is a diagram illustrating a signaling procedure between a Node B and a UE to perform dynamic channel allocation and adaptive modulation in a typical mobile communication system. In the illustrated case, a Node B 110 supports the dynamic channel allocation and adaptive modulation and a UE 120 receives data on a channel dynamically allocated by the Node B 110.

[0006] Referring to FIG 1, when a downlink directed from the Node B 110 to the UE 120 is established in step 102, the Node B 110 notifies the UE 120 of parameters required for the dynamic channel allocation, inclusive of a transmission period, by signaling in step 104. The UE 120 estimates the channel quality value of a signal received from the Node B 110 and reports the channel quality value to the Node B 110 at a time point set according to the transmission period in step 106.

35 [0007] While only one UE 120 is shown, all UEs within the cell area of the Node B 110 behave in the same manner so that the Node B 110 acquires the channel quality values of all subcarriers from every UE.

40 [0008] Once the Node B has all the channel quality values from the UEs, the Node B 110 schedules data transmission for the UEs based on the channel quality values, thereby determining channels to be allocated and modulation schemes for the UEs. After scheduling, the Node B 110 notifies the UE 120 of the result by signaling and transmits data on a downlink traffic channel to the UE 120 in step 108. The UE demodulates the data to obtain the determined modulation scheme.

45 [0009] Periodic dynamic channel allocation in the Node B requires reporting of the channel quality information for all the total subcarriers from UEs, creating a large uplink signaling overhead. To reduce overhead, prior art OFDM systems regulate the total subcarriers into a plurality of groups and transmits channel quality information on a subcarrier group basis. Configuring the number of the subcarrier groups is a huge challenge depending on channel condition and system parameters; overhead is inevitable to a certain extent. Accordingly, a need exists for a technique of allocating subcarrier groups and efficiently transmitting channel quality information in a manner that minimizes uplink overhead in transmission of the channel quality information in a mobile communication system supporting dynamic channel allocation and adaptive modulation.

**SUMMARY OF THE INVENTION**

55 [0010] An object of the present invention is to substantially solve at least the above problems and/or disadvantages and to provide at least the advantages below. Accordingly, an object of the present invention is to provide a method of transmitting channel quality information required for dynamic channel allocation to allow multiple accesses in an OFDM communication system using a time-division channel transmission scheme to perform the dynamic channel allocation and adaptive modulation.



## EP 1 569 403 A2

**[0011]** Another object of the present invention is to provide a method of reducing uplink overhead in transmitting channel quality information in an OFDM communication system using a time-division channel transmission scheme to perform dynamic channel allocation and adaptive modulation.

5 **[0012]** A further object of the present invention is to provide a method of determining parameters required for time-division transmission of a downlink channel in an asynchronous CDMA-OFDM communication system.

**[0013]** The above objects are achieved by providing a method and apparatus for efficiently transmitting channel quality information in an OFDM communication system using dynamic channel allocation and adaptive modulation, and determining parameters required for time-division channel quality information transmission in an asynchronous CDMA communication system.

10 **[0014]** According to one aspect of the present invention, in a method of reporting channel quality information from a plurality of UEs in an OFDM communication system in which a plurality of subcarriers are allocated to the plurality of UEs, the number of subcarrier groups ( $N_G$ ) and a feedback cycle ( $k$ ) are determined so that each subcarrier group is within a coherence bandwidth, the total subcarriers are divided into a plurality of subcarrier groups each having at least one subcarrier according to  $N_G$  and  $k$ , and channel quality values of the subcarrier groups are determined and transmitted according to  $N_G$  and  $k$  so that the CQI quality values from the UEs do not overlap in transmission.

15 **[0015]** According to another aspect of the present invention, in an OFDM communication system in which a plurality of subcarriers are allocated to a plurality of UEs, each of the UEs determines the number of subcarrier groups ( $N_G$ ) and a feedback cycle ( $k$ ) so that each subcarrier group is within a coherence bandwidth, divides total subcarriers into a plurality of subcarrier groups each having at least one subcarrier according to  $N_G$  and  $k$ , determines channel quality values of the subcarrier groups, and transmits the channel quality values according to  $N_G$  and  $k$  so that the CQI quality values are not overlapped with CQI quality values from other UEs. A Node B receives the channel quality values at channel quality transmission times, and dynamically allocates the subcarriers to the UEs and determining modulation schemes for the UEs according to the channel quality values.

25 **BRIEF DESCRIPTION OF THE DRAWINGS**

**[0016]** The above and other objects, features and advantages of the present invention will become more apparent from the following detailed description when taken in conjunction with the accompanying drawings in which:

30 FIG. 1 is a diagram illustrating a signaling procedure for dynamic channel allocation and adaptive modulation between a Node B and a UE in a typical mobile communication system;

FIG. 2 illustrates the structure of an HS-DPCCH (High Speed-Dedicated Physical Control Channel) frame for delivering a CQI (Channel Quality Indicator) in an asynchronous CDMA communication system;

FIG. 3 is a diagram illustrating the timing of transmitting channel quality information in a UE;

35 FIG. 4 is a block diagram of a transmitter in an OFDM system according to a preferred embodiment of the present invention;

FIG. 5 is a block diagram of a receiver in an OFDM system according to a preferred embodiment of the present invention;

40 FIG. 6 is a block diagram of a UE device for time-division CQI transmission according to a preferred embodiment of the present invention;

FIG. 7 is a block diagram of a Node B device for time-division CQI reception according to a preferred embodiment of the present invention;

FIG. 8 is a detailed block diagram of a CQI generator according to a preferred embodiment of the present invention;

45 FIG. 9 is a diagram describing a geometric average modeling technique in which the group power of a  $j$ -th group including  $N$  parallel subcarriers is obtained through geometric-average-modeling of the channel power of the  $j$ -th group;

FIG. 10 is a diagram illustrating the timing of time-division CQI transmission according to a preferred embodiment of the present invention;

50 FIGs. 11A and 11B illustrate exemplary CQI transmissions according to a preferred embodiment of the present invention;

FIG. 12 is a flowchart illustrating a CQI transmission operation in the UE according to a preferred embodiment of the present invention;

FIG. 13 is a flowchart illustrating a CQI reception operation in the Node B according to a preferred embodiment of the present invention; and

55 FIG. 14 is a flowchart illustrating an operation for determining parameters required for dynamic channel allocation based on the CQI transmission scheme according to a preferred embodiment of the present invention.

## EP 1 569 403 A2

## DETAILED DESCRIPTION OF THE PREFERRED EMBODIMENTS

5 **[0017]** Preferred embodiments of the present invention will be described herein below with reference to the accompanying drawings. In the following description, well-known functions or constructions are not described in detail since they would obscure the invention in unnecessary detail.

**[0018]** A cell typically serves as the physical layer of the Node B to which it belongs in a mobile communication system. Therefore, the following description of the present invention is made with the understanding that the terms "Node B" and "cell" are interchangeably used or one Node B corresponds to one cell.

10 **[0019]** The present invention achieves efficient transmission of a CQI for the purpose of dynamic channel allocation and adaptive modulation in an OFDM system. Specifically, the present invention is intended to efficiently transmit CQIs in an OFDM communication supporting dynamic channel allocation and adaptive modulation and to determine parameters to transmit CQIs in time-division in an asynchronous CDMA communication system.

**[0020]** Asynchronous CDMA communication system can apply OFDM to HSDPA (High Speed Downlink Packet Access) downlink channels. Now a description will be made of the definition of channel quality information, its transmission timing, and its related parameters in the typical asynchronous CDMA communication system.

15 **[0021]** The asynchronous CDMA communication system spreads data for every user over the entire frequency band. Therefore, only the CQI of the channel covering the full frequency range exists. To transmit the CQI and data, a UE preliminarily acquires control information from Node B by signaling, such as the allowed maximum number of retransmission responses, the feedback period of the CQI, the allowed maximum number of CQI repeated transmissions, and a power offset. When the UE makes a call, it continuously monitors a full HS-SCCH (High Speed Shared Control Channel), while periodically transmitting the CQI on an HS-DPCCH. Upon detection of control information needed for data reception, the UE receives data on an HS-PDSCH (High Speed Physical Downlink Shared Channel) based on the control information from the Node B.

20 **[0022]** FIG. 2 illustrates the structure of an HS-DPCCH frame for delivering a CQI in an asynchronous CDMA communication system according to an embodiment of the present invention.

**[0023]** Referring to FIG. 2, the HS-DPCCH has 10-ms radio frames 204, each radio frame including five 2-ms subframes 202, subframe #0 to subframe #4. Each subframe 202 is divided into a 2560-chip time slot (Ts) for delivering an HARQ (Hybrid Automatic Repeat Request) ACK/NACK (Acknowledgement/Non-Acknowledgement) and a 5120-chip CQI.

25 **[0024]** FIG. 3 is a diagram illustrating the timing of transmitting the CQI in the UE. In the illustrated case, the timings of an uplink DPCH (Dedicated Physical Channel) 206, an HS-DPCCH 210, and an HS-PDSCH 208 are shown.

**[0025]** Referring to FIG. 3, the HS-DPCCH frame 210, which carries the CQI, starts an  $m$  multiple of 256 chips ( $m \times 256$  chips) after the start of the associated uplink DPCH 206 frame. The value  $m$  is defined as set forth in Equation (1) to be:

$$35 \quad m = (T_{TX\_diff} / 256) + 101 \quad (1)$$

where  $T_{TX\_diff}$  is the transmission timing offset between the uplink DPCH 206 and the HS-PDSCH 208, expressed in units of chip. The transmission timing offset  $\tau_{UEP}$  between the HS-PDSCH 208 and the HS-DPCCH 210 is about 19200 chips, equivalent to the processing delay of the UE.

40 **[0026]** The accurate start timing of the HS-DPCCH 210 is a time slot (slot #11 in FIG. 3) which is  $i$  time slots away from the start of the uplink DPCH frame 206 (slot #0 in FIG. 3). The value  $i$  satisfies Equation (2):

$$45 \quad (5 \times CFN + ((n \times 256 + i \times 2560) / 7680)) \bmod k = 0 \text{ and } i \bmod 3 = 0 \quad (2)$$

where CFN (Connection Frame Number) is the CFN of the uplink DPCH 206 and  $n$  is a timing offset equal to  $m$  defined as Equation (1). The CQI is transmitted repeatedly as many times as  $(N\_cqi\_transmit-1)$ , starting from the start of the HS-DPCCH frame 210.  $N\_cqi\_transmit-1$  is a parameter received from a higher layer.

50 **[0027]** If the UE transmits a particular CQI, it indicates that data transmission by a transport block (TB) size and modulation scheme corresponding to the CQI or less does not exceed a predetermined threshold for the PER (Packet Error Rate) of single channel transmission. The CQI in the HS-DPCCH frame is 5 bits. The UE and the Node B each have the same mapping table with mapping information including TB sizes, numbers of HS-PDSCH codes, and modulations for available CQIs and UE types.

55 **[0028]** The mapping table lists TB sizes, numbers of codes used, and modulations that satisfy CQIs and PERs considering SNRs (Signal to Noise Ratio) of the HS-DPSCH according to simulated single transmission PER performance in an AWGN (Additive White Gaussian Noise) environment.

## EP 1 569 403 A2

**[0029]** The channel power of the HS-PDSCH is calculated by adding a predetermined power offset to a CPICH (Common Pilot Channel) transmitted by Node B. That is, as shown in Equation (3):

$$P_{HS-PDSCH} = P_{CPICH} + \Gamma + \Delta[dB] \quad (3)$$

where  $\Gamma$  is a parameter determining the power offset between the CPICH and the HS-PDSCH, received by signaling from a higher layer, and  $\Delta$  is a parameter representing an available channel power decrement. If a TB size corresponding to the calculated HS-PDSCH power is larger than a maximum TB size that the UE can support, the UE can transmit data in the maximum TB size and its corresponding modulation scheme with a channel power decrease of  $\Delta$ , satisfying a required PER.

**[0030]** FIG. 4 is a block diagram of a transmitter in an OFDM system according to a preferred embodiment of the present invention. The transmitter is configured to transmit user data for K UEs on N subcarriers. The N subcarriers are divided into K subcarrier groups, each subcarrier group being allocated to one UE. Preferably, each subcarrier group has at least one subcarrier and N is equal to or larger than K.

**[0031]** Referring to FIG 4, K feedback CQIs from K UEs are stored as the channel quality information of channels between the K UEs and the Node B in user channel information memory 314 and then provided to a subcarrier allocator 316 and a bit allocator 318. The subcarrier allocator 316 allocates the whole subcarrier groups to the K UEs according to the CQIs. The subcarrier group allocation will be described later.

**[0032]** The bit allocator 318 allocates bits referring to the CQIs of the K UEs and subcarrier group allocation information that it receives from the subcarrier allocator 316. Specifically, the bit allocator 318 determines a modulation scheme for each UE and the bit positions for modulation symbol mappings. The subcarrier group allocation information from the subcarrier allocator 316 and bit allocation information from the bit allocator 318 are provided to a control signal generator 302 and an adaptive modulator 304.

**[0033]** The control signal generator 302 generates a control signal according to the subcarrier group allocation information and the bit allocation information. The adaptive modulator 304 adaptively modulates user data for the K UEs based on the bit allocation information.

**[0034]** A frequency selector 306 maps the control signal received from the control signal generator 302 and modulated data received from the adaptive modulator 304 to appropriate frequencies, or subcarriers. The frequency selector 306 allocates each group of subcarriers to a corresponding UE. An IFFT (Inverse Fast Fourier Transform) 308 performs an N-point IFFT on the output of the frequency selector 306.

**[0035]** A parallel to serial converter (PSC) 310 receives the IFFT signal and a cyclic prefix (CP). The CP is a signal transmitted for a guard interval. It cancels interference between the previous OFDM symbol and the current OFDM symbol. The guard interval can be implemented as a prefix by inserting a copy of the last predetermined bits of a time-domain OFDM symbol into an effective OFDM symbol or as a postfix by inserting a copy of the first predetermined bits of the time-domain OFDM symbol into the effective OFDM symbol.

**[0036]** The PSC 310 serializes the IFFT signal and the CP. After RF (Radio Frequency) processing (not shown), the serial signal is transmitted through an antenna 312.

**[0037]** For the RF processing, a digital to analog converter (DAC) (not shown) converts the serial signal received from the PSC 310 to an analog signal. An RF processor, including a filter and front end units, processes the analog signal to an RF signal suitable for transmission over the air and outputs the RF signal to the antenna 312.

**[0038]** The configuration of the transmitter in the OFDM communication system has been described above with reference to FIG 4. Now, a description will be made of a receiver in the OFDM communication system with reference to FIG 5 which is a block diagram of a receiver in an OFDM communication system according to a preferred embodiment of the present invention.

**[0039]** Referring to FIG 5, the signal from the transmitter of FIG 4 is propagated on a multipath channel and noise is added before arriving at a receive antenna 402 in the UE. The received signal is converted to a digital signal through an RF processor (not shown) and an analog to digital converter (ADC) (not shown). A serial to parallel converter (SPC) 404 converts the digital signal to parallel signals and provides the remaining signal from which a CP signal is removed to an FFT (Fast Fourier Transform) 406.

**[0040]** The IFFT 406 performs an N-point FFT on the signal received from the SPC 404. A frequency distributor 408 provides a control signal processor 410 with a subcarrier signal to which a control signal was mapped and a Subcarrier Selector & Adaptive Demodulator 412 with a subcarrier signal to which user data was mapped in the FFT signal. The subcarrier Selector & Adaptive Demodulator 412 demodulates the input signal and extracts desired k-th user data using subcarrier group allocation information and bit allocation information generated by the control signal processor 410.

**[0041]** The operation of the subcarrier Selector & Adaptive Demodulator 412 will now be described in more detail.

## EP 1 569 403 A2

- [0042]** Since the Node B transmits user data for the  $k$ -th UE over a predetermined subcarrier group according to the subcarrier group allocation information, the subcarrier Selector and Adaptive Demodulator 412 selects the subcarrier group allocated to the  $k$ -th UE based on the subcarrier group and bit allocation information from the control signal processor 410, demodulates the input signal by the demodulation method of the bit allocation information, and decodes the  $k$ -th user data.
- [0043]** In relation to the above-described transmitter and receiver configurations, if UEs generate the CQIs, buffer them, and transmit them simultaneously, it creates substantial uplink overhead. In accordance with a preferred embodiment of the present invention, the CQIs of a plurality of subcarrier groups are transmitted over time, reducing uplink overhead.
- [0044]** Before a detailed description of a preferred embodiment of the present invention, variables used herein will be defined as follows.
- [0045]**  $\Gamma$  is the power offset between the CPICH and the HS-PDSCH,  $\Delta$  is a reference power adjustment value,  $N_G$  is the number of subcarrier groups, each having at least one subcarrier,  $N_{\text{spacing}}$  is the spacing between subframes that deliver the CQIs of the subcarrier groups, and  $k$  is a CQI feedback cycle.
- [0046]** FIG. 6 is a block diagram of a UE device for time-division CQI transmission according to a preferred embodiment of the present invention. The UE device is configured to receive a CPICH signal, generate CQIs using the CPICH signal, and transmit the CQIs on the HS-DPCCH.
- [0047]** Referring to FIG 6, a CQI generator 502 generates CQIs using an OFDM-CPICH signal received from Node B. To that end, the CQI generator 502 utilizes the parameters of  $\Gamma$ ,  $\Delta$ , and a PER threshold and a CQI table obtained by simulation. The CQI generator 502 calculates the CQIs of the total subcarrier groups at one time and sequentially stores them in a buffer 504. The number of the calculated CQIs is equal to that of the subcarrier groups,  $N_G$ .
- [0048]** A CQI transmission time decider 506 turns on a switch 508 when it is time to transmit the CQIs according to transmission parameters that determine the CQI transmission time,  $N_G$ ,  $N_{\text{spacing}}$ , and  $k$ , that is, a transmission schedule to transmit the buffered CQIs.
- [0049]** The CQI transmission time decider 506 determines the transmission time points so that the buffered CQIs of the total subcarrier groups are transmitted within one feedback cycle,  $k$ (ms). One CQI transmission time point is spaced from another by  $N_{\text{spacing}}$ . Thus, the CQI transmission time decider 506 receives the transmission parameters of the time interval between subcarrier group-specific CQIs,  $N_{\text{spacing}}$ , the number of the subcarrier groups  $N_G$ , and the feedback cycle  $k$ .
- [0050]** The value  $k$  is a time period for which all the CQIs are completely transmitted for a new dynamic channel allocation. Therefore, it may be assumed that the entire channel information is transmitted for every period of  $k$ .  $N_{\text{spacing}}$  is the time interval between transmission time points at which the CQIs of subcarrier groups are transmitted within  $k$ . How the CQIs are transmitted will be described in detail with reference to FIG. 10.
- [0051]** In FIG 6, as the switch 508 is turned on by the CQI transmission time decider 506, one CQI from the buffer 504 is channel-encoded in a channel encoder 510. As described before with reference to FIG 2, the HS-DPCCH delivers an ACK/NACK as a 10-bit HARQ response and a 20-bit CQI together. Therefore, an HARQ ACK/NACK occurs 10 times in the channel encoder 514. The 10-times repetition encoding compensates for the length difference between the HARQ ACK/NACK and the CQI because the 10-bit HARQ ACK/NACK occupies one time slot and the 20-bit CQI takes two.
- [0052]** A multiplexer (MUX) 512 time-division-multiplexes the outputs of the channel encoders 510 and 514 and transmits the multiplexed signal on the HS-DPCCH.
- [0053]** FIG. 7 is a block diagram of a Node B device for CQI reception according to a preferred embodiment of the present invention. The Node B device is configured to receive CQIs from a  $k$ -th UE among  $K$  UEs.
- [0054]** Referring to FIG. 7, a demultiplexer (DEMUX) 602 demultiplexes an HS-DPCCH signal from the UE into a CQI signal and an HARQ ACK/NACK signal. A CQI reception time decider 604 determines the reception time of the CQI signal received from the DEMUX 602 based on the CQI transmission parameters,  $N_G$ ,  $N_{\text{spacing}}$  and  $k$ . A switch 606 turns on at the reception time determined by the reception time decider 604. A channel decoder 608 decodes the CQI signal and extracts a CQI value. The CQI value is stored in the user channel information memory 314 as user channel information.
- [0055]** A channel decoder 610 repetition-decodes the HARQ ACK/NACK signal in correspondence with the channel encoder 514 and extracts an ACK/NACK for HARQ. The ACK/NACK is used to determine whether to retransmit packet data transmitted on the HS-PDSCH to the UE.
- [0056]** Now, the structure of the CQI generator 502 will be described in detail with reference to FIG 8.
- [0057]** Referring to FIG. 8, a CPICH channel power measurer 702 measures the channel power of each OFDM-CPICH subcarrier and calculates the power of each subcarrier group based on the measured channel power values. To model a plurality of subcarrier power values into one group power value, the geometric average of the total subcarrier power values is calculated.
- [0058]** FIG 9 illustrates a geometric average modeling technique for calculating the group power of a  $j$ -th group

## EP 1 569 403 A2

including N parallel subcarriers by geometric-average-modeling the channel power of the  $j$ -th group.

**[0059]** As illustrated in FIG. 9, the  $j$ -th subcarrier group includes N subcarriers and the power values of the N subcarriers are respectively denoted by  $P_1, P_2, \dots, P_N$ . With respect to the N power values, one group representative power value is obtained by Equation (4):

$$H_{HS-PDSCHj} = P_{CPICHj} + \Gamma + \Delta [dB]$$

$$P_{CPICHj} = [\prod_{i=1}^L (1+P_i)]^{-1} \quad (4)$$

where 1 is the index of a subcarrier in the  $j$ -th group and the group representative value,  $P_{CPICHj}$  is produced by equivalent-channel-modeling one subcarrier group with one equivalent subcarrier. And  $\Pi$  is an operator of multiplying first through L-th elements.

**[0060]** An HS-PDSCH group power calculator 704 calculates HS-PDSCH power values  $P_{HS-PDSCHj}$  ( $j=1, \dots, N_G$ ) using the CPICH group representative values  $P_{CPICHj}$  and  $\Delta$  by Equation (5):

$$P_{HS-PDSCHj} = P_{CPICHj} + \Gamma + \Delta \quad (5)$$

where  $\Gamma$  is the power offset between the OFDM CPICH and the OFDM HS-PDSCH, known by higher layer signaling, and  $\Delta$  is a reference power adjustment value.

**[0061]** Referring back to FIG 8, CQI decider 706 determines the CQIs of the subcarrier groups,  $CQI_j$  based on  $P_{HS-PDSCHj}$ . The CQIs can translate into SNRs, TB sizes, and data rates. That is, the CQI decider 706 selects the highest available CQI according to an input  $P_{HS-PDSCHj}$  value referring to a preset CQI table 708 that is based on the simulated PER performance of an AWGN channel with respect to the power (i.e. SNR) of the OFDM HS-PDSCH.

**[0062]** FIG 10 is a diagram illustrating the timing of time-division CQI transmission according to a preferred embodiment of the present invention.

**[0063]** Referring to FIG 10, the CQI feedback cycle 806 of the total subcarrier groups is  $k$  ms. Since one subframe is 2ms in duration,  $k/2$  subframes exist within one feedback cycle. For example, the  $k/2$  subframes be numbered 0, 1, ...,  $k/2-1$  and a set of the numbers of sub frames delivering  $N_G$  CQIs 802 be denoted by  $S_{N_{spacing}}$ . The number of elements in  $S_{N_{spacing}}$  is equal to  $N_G$  because the CQIs of the total subcarrier groups are to be transmitted. The timing of the first subframe is illustrated in FIG 2.

**[0064]** CQIs are transmitted at the same intervals  $N_{spacing}$ , and thus,  $S_{N_{spacing}}$  is given by Equation (6):

$$S = \{0, 1 \times N_{spacing}, \dots, (N_G - 1) \times N_{spacing}\} \quad (6)$$

**[0065]** Minimum spacing is 1 ( $N_{spacing\_MIN}=1$ [subframe]) in transmitting  $N_G$  CQIs within  $k$  ms. In this case, all channel information is successively transmitted in the first  $N_G$  subframes. As indicated by reference numeral 804, a maximum spacing is  $\text{mod}(k/2N_G)$  ( $N_{spacing\_MAX}=k/2N_G$ [subframe]). With maximum spacing, the channel information is distributed as much as possible, thereby minimizing uplink overhead.

**[0066]** FIGs. 11A and 11B illustrate exemplary CQI transmissions according to a preferred embodiment of the present invention. Reference numeral 902 denotes the CQIs of  $N_G$  subcarrier groups  $CQI_1, \dots, CQI_{N_G}$ , reference numeral 904 denotes available  $N_{spacing}$  values, and reference numeral 906 denotes the feedback cycle of the total CQI values.

**[0067]** In FIG 11A, for  $k=40$ ms and  $N_G=6$ , available  $N_{spacing}$  values are 1, 2, 3. As a result, the timing sets 908, 910 and 912 are  $S_1=\{0, 1, 2, 3, 4, 5\}$ ,  $S_2=\{0, 2, 4, 6, 8, 10\}$ , and  $S_3=\{0, 3, 6, 9, 12, 15\}$ , respectively. In three sets, the first transmission time is equal, but the last transmission time is different, so CQI transmission is completed at different times.

**[0068]** FIG. 12 is a flowchart illustrating a CQI transmission operation in the UE according to a preferred embodiment of the present invention. Referring to FIG. 12, a subcarrier group index identifying a subcarrier group,  $n$  is set to 0 in step 1000. The CPICH group power measurer 702 measures the power values of the OFDM CPICH on a subcarrier basis in step 1002 and calculates the equivalent power value of every subcarrier group in step 1004. In step 1006, the HS-PDSCH group power calculator 704 calculates the power values of the HS-PDSCH based on the equivalent group power values.

**[0069]** Upon input of the CQI table 708 in step 1010, the CQI decider 706 obtains optimum CQIs that allow transmission of a maximum amount of data, satisfying a given PER, referring to the CQI table 708 in step 1008. In step 1012, the optimum CQIs are stored in the buffer 504.

**[0070]** In step 1014, the CQI transmission time decider 506 determines whether to transmit a CQI according to given

## EP 1 569 403 A2

parameters,  $N_G$ ,  $N_{\text{spacing}}$  and  $k$  at the current time. If it is time to transmit, the procedure goes to step 1016 and transmits the CQI. Otherwise, the process returns to step 1002.

**[0071]** When the CQI of a subcarrier group,  $CQI_n$  is transmitted in step 1016, it is determined whether the subcarrier group is the last one by comparing  $n$  with  $N_G$  in step 1018. If the CQI of the last subcarrier group has been transmitted, the procedure is terminated. If a CQI to be transmitted still remains,  $n$  is incremented by 1 in step 1020 and the procedure returns to step 1014. Steps 1014 to 1020 are repeated until the all CQIs are transmitted.

**[0072]** FIG. 13 is a flowchart illustrating CQI reception in the Node B according to a preferred embodiment of the present invention.

**[0073]** Referring to FIG. 13, the Node B receives an HS-DPCCH signal from the UE in step 1102. In step 1104, the DEMUX 602 demultiplexes the HS-DPCCH signal into a CQI signal and an HARQ ACK/NACK signal. The CQI reception time decider 604 determines whether it is time to receive a CQI according to given parameters,  $N_G$ ,  $N_{\text{spacing}}$  and  $k$  in step 1106. If it is, the procedure proceeds to step 1108 and otherwise, the procedure returns to step 1102.

**[0074]** In step 1108, the switch 606 switches the CQI signal to the channel decoder 608 to receive the CQI. The channel decoder 608 extracts the CQI by the appropriate decoding process in step 1110 to acquire and store the CQI in step 1112 as channel information for use in subcarrier group allocation and bit allocation in the user channel information memory 314.

**[0075]** FIG. 14 is a flowchart illustrating an operation for determining parameters for dynamic channel allocation based on the CQI transmission scheme where OFDM is adopted for HSDPA downlink channels in the asynchronous CDMA communication system according to a preferred embodiment of the present invention. The parameters to be determined are  $N_G$ ,  $k$  and  $N_{\text{spacing}}$ . These parameters depend on channel condition, specifically a coherence bandwidth  $f_c$  and a coherence time  $t_c$ . The following operation is performed in a Node B or in an RNC (Radio Network Controller).

**[0076]** Referring to FIG. 14,  $N_G$  is calculated in step 1202. According to the above-described CQI transmission scheme, a CQI representative of the subcarriers of one subcarrier group is calculated by Eq. (4) and thus the subcarriers have similar channel gains. A coherence bandwidth typically refers to a bandwidth over which channel frequency response is considered flat. For a whole frequency band  $B_f$ , therefore, the frequency band that one subcarrier group occupies,  $B_f/N_G$  should be less than  $f_c$ . Therefore,  $N_G$  is a positive integer satisfying Equation (7):

$$N_G \geq \frac{B_f}{f_c} \quad (7)$$

**[0077]** In step 1204,  $k$  is selected. Since an HS-DPCCH transmission unit, subframe is 2ms in duration,  $k$  is a multiple of 2, and a minimum value of  $k$  for transmitting the CQIs of the total subcarrier group, each CQI being delivered in one subframe is  $2 \times N_G$ . In addition, to render channel characteristics constant in one symbol period,  $k$  should be less than  $t_c$ . The coherence time is the inverse of a Doppler frequency range in which the channel remains constant over time and is affected by the speed of a UE. Considering these conditions,  $k$  is an integer being a multiple of 2 and satisfying Equation (8):

$$2 \times N_G \leq k \leq t_c \quad (8)$$

**[0078]** In step 1206, a multiple of 2 satisfying Equation (8) is determined as  $k$ , while increasing  $k$  to 2, 4, 6, 8 sequentially.

**[0079]**  $N_{\text{spacing}}$  is set to a random number in step 1208 and it is determined whether the set  $N_{\text{spacing}}$  is a positive integer satisfying

$$1 \leq N_{\text{spacing}} \leq \text{mod} \left( \frac{k/2}{N_G} \right),$$

thereby deciding an appropriate  $N_{\text{spacing}}$  value in step 1210.

**[0080]** In step 1212, the determined parameters,  $k$ ,  $N_G$ , and  $N_{\text{spacing}}$  are transmitted to the UE by RRC (Radio Resource Control) signaling.

**[0081]** In accordance with the present invention as described above, each of UEs determines the CQIs of subcarrier groups and transmits them according to predetermined transmission parameters at transmission time points that do not overlap with those of other UEs. A Node B dynamically allocates subcarriers to the UEs and modulation schemes

## EP 1 569 403 A2

for them according to the CQIs received from the UEs. Therefore, the amount of channel information transmitted is reduced, thereby effectively reducing uplink signaling overhead.

**[0082]** While the invention has been shown and described with reference to certain preferred embodiments thereof, it will be understood by those skilled in the art that various changes in form and details may be made therein without departing from the spirit and scope of the invention as defined by the appended claims.

### Claims

- 10 1. A method of reporting channel quality information from a plurality of user equipments (UEs) in an orthogonal frequency division multiplexing (OFDM) communication system in which a plurality of subcarriers are allocated to the plurality of UEs comprising:
- 15 determining the number of subcarrier groups ( $N_G$ ) and a feedback cycle ( $k$ ) so that each subcarrier group is within a coherence bandwidth;  
dividing total subcarriers into a plurality of subcarrier groups each having at least one subcarrier according to  $N_G$  and  $k$ ;  
determining channel quality values of the subcarrier groups; and  
20 transmitting the channel quality values according to  $N_G$  and  $k$  so that the CQI quality values from the UEs do not overlap in transmission.
2. The method of claim 1, wherein the transmission step comprises:
- 25 controlling a transmission time spacing ( $N_{\text{spacing}}$ ) between the channel quality values of the subcarrier groups without overlap between the UEs; and,  
transmitting the channel quality values according to  $N_{\text{spacing}}$ .
3. The method of claim 2, wherein  $N_{\text{spacing}}$  is a positive integer between 1 and  $\text{mod}(k/(a \times N_G))$  where  $a$  is a minimum data unit for transmitting a channel quality value.
- 30 4. The method of claim 1, wherein  $k$  is an integer between  $2N_G$  and coherence time ( $t_c$ ) and a multiple of the minimum data unit.
5. The method of claim 1, wherein  $N_G$  is an integer larger than the value of dividing a total frequency bandwidth ( $B_p$ ) by a coherence bandwidth ( $f_c$ ).
- 35 6. The method of claim 1, wherein the channel quality value determining step comprises:
- 40 measuring power values of an OFDM-CPICH (Common Pilot Channel) signal received on the plurality of subcarriers from a Node B;  
calculating the CPICH group power value of the subcarrier groups by geometric-average-modeling the CPICH power values on a subcarrier group basis;  
calculating HS-PDSCH (High Speed Physical Downlink Shared Channel) group power values by summing the CPICH group power values, a power offset between an HS-PDSCH and the CPICH, and a reference power  
45 adjustment value; and  
determining the channel quality values for the HS-PDSCH group power values, the channel quality values allowing transmission of a maximum amount of data while satisfying a given packet error rate.
7. The method of claim 6, wherein the channel quality values are signal to noise ratios (SNRs) or transport block sizes.
- 50 8. The method of claim 1, further comprising:
- receiving the channel quality values; and  
dynamically allocating the subcarriers to the UEs and determining modulation schemes for the UEs according  
55 to the channel quality values.
9. An orthogonal frequency division multiplexing (OFDM) communication system in which a plurality of subcarriers are allocated to a plurality of user equipments (UEs), comprising:

## EP 1 569 403 A2

- 5 a Node B for determining the number of subcarrier groups ( $N_G$ ) and a feedback cycle ( $k$ ) so that each subcarrier group is within a coherence bandwidth, dividing total subcarriers into a plurality of subcarrier groups each having at least one subcarrier according to  $N_G$  and  $k$ , receiving the channel quality values of the subcarrier groups at channel quality transmission times, and dynamically allocating the subcarriers to the UEs and determining modulation schemes for the plurality of UEs according to the channel quality values; and the plurality of UEs each determining channel quality values of the subcarrier groups, and transmitting the channel quality values according to  $N_G$  and  $k$  so that the CQI quality values are not overlapped with CQI quality values from other UEs.
- 10 10. The OFDM communication system of claim 9, wherein the Node B controls a transmission time spacing ( $N_{\text{spacing}}$ ) between the channel quality values of the subcarrier groups without overlap between the UEs, and the UEs transmit the channel quality values according to  $N_{\text{spacing}}$ .
- 15 11. The OFDM communication system of claim 10, wherein  $N_{\text{spacing}}$  is a positive integer between 1 and  $\text{mod}(k/(a \times N_G))$  where  $a$  is a minimum data unit for transmitting a channel quality value.
12. The OFDM communication system of claim 11, wherein  $k$  is an integer between  $2N_G$  and a coherence time ( $t_c$ ) and a multiple of the minimum data unit.
- 20 13. The OFDM communication system of claim 9, wherein  $N_G$  is an integer larger than the value of dividing a total frequency bandwidth ( $B_r$ ) by a coherence bandwidth ( $f_c$ ).
- 25 14. The OFDM communication system of claim 9, wherein at least one of the UEs measures the power values of an OFDM-CPICH (Common Pilot Channel) signal received on the plurality of subcarriers from the Node B, calculates the CPICH group power value of every subcarrier group by geometric-average-modeling the CPICH power values on a subcarrier group basis, calculates HS-PDSCH (High Speed Physical Downlink Shared Channel) group power values by summing the CPICH group power values, a power offset between an HS-PDSCH and the CPICH, and a reference power adjustment value, and determines the channel quality values for the HS-PDSCH group power values, the channel quality values allowing transmission of a maximum amount of data, satisfying a given packet error rate.
- 30 15. The OFDM communication system of claim 14, wherein the channel quality values are signal to noise ratios (SNRs) or transport block sizes.
- 35
- 40
- 45
- 50
- 55



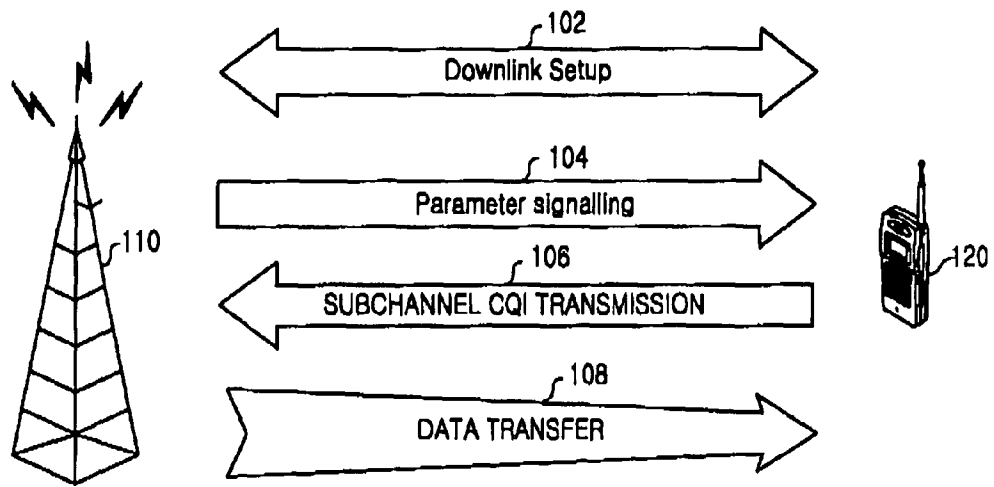

FIG. 1

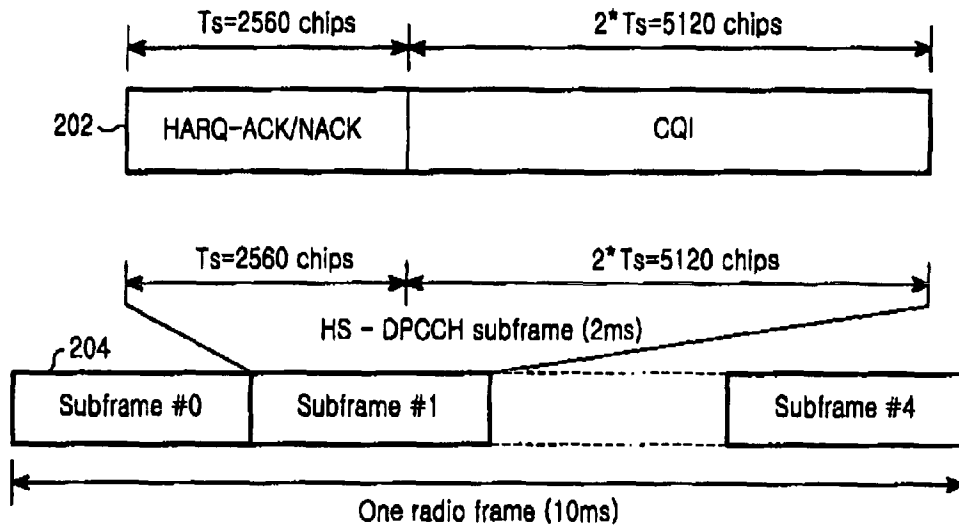

FIG.2

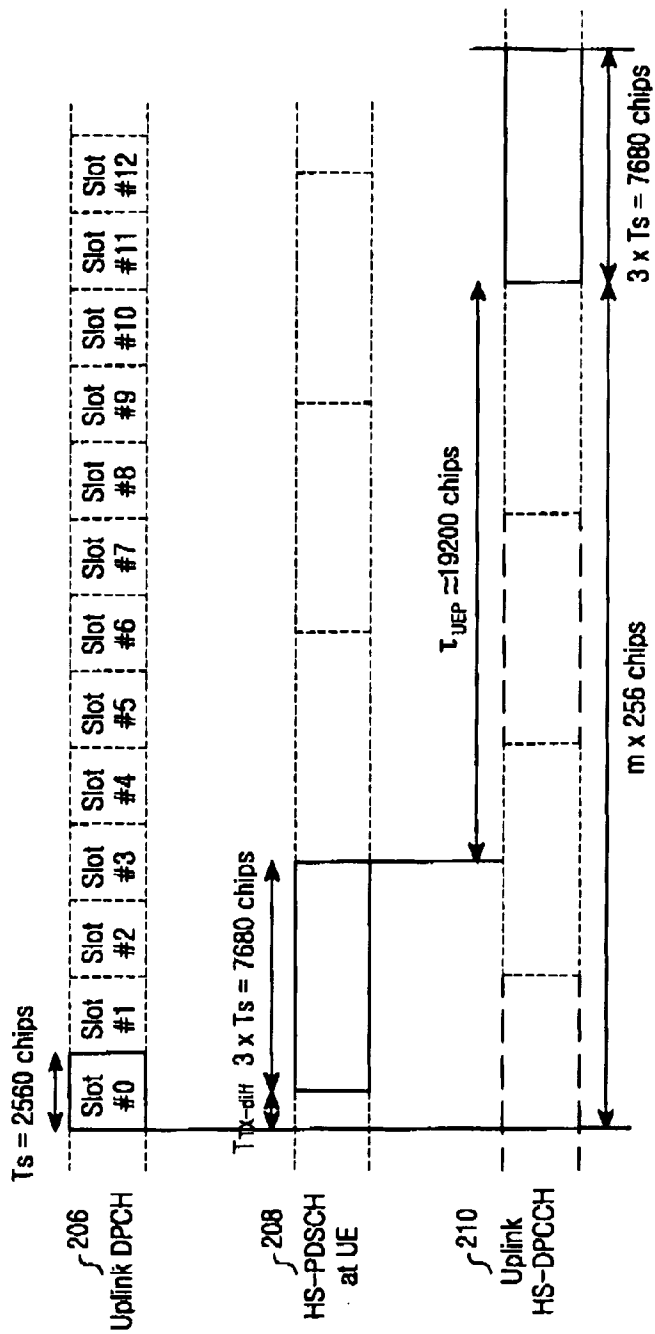

FIG.3

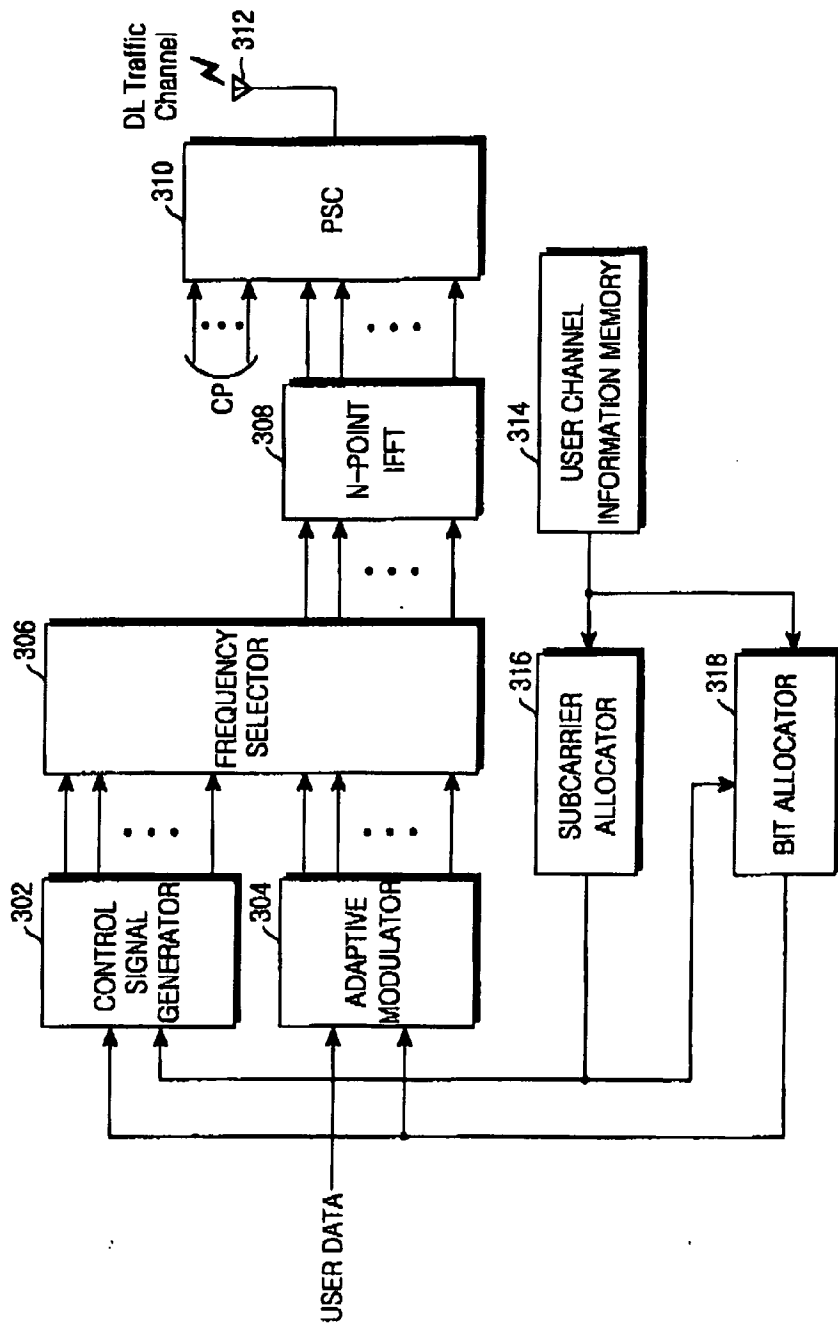

FIG.4

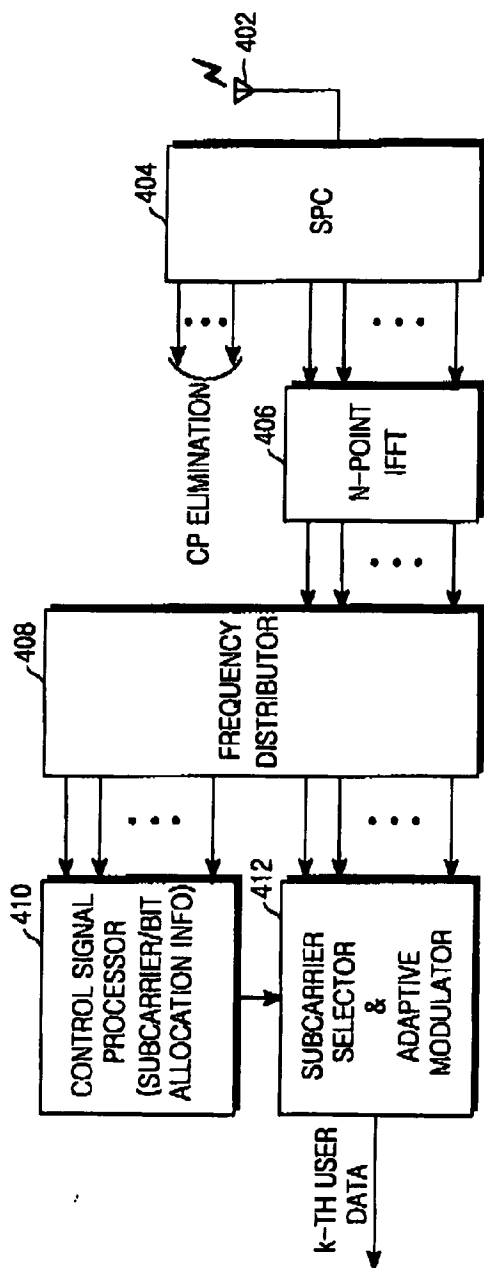

FIG.5

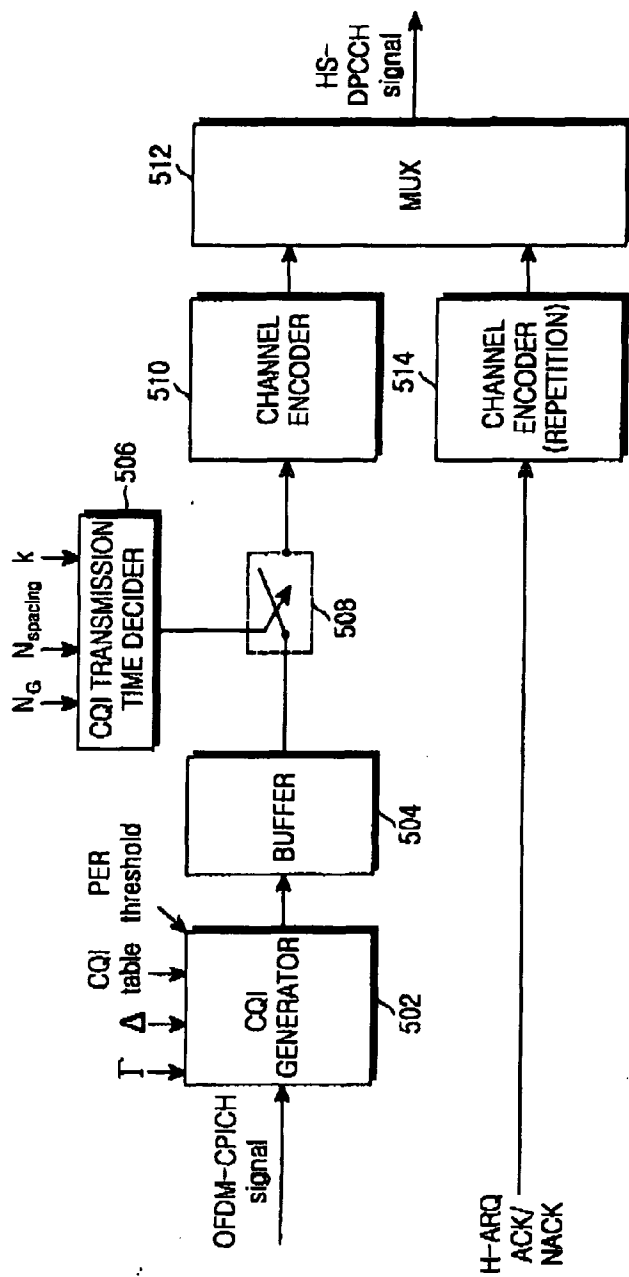

FIG.6

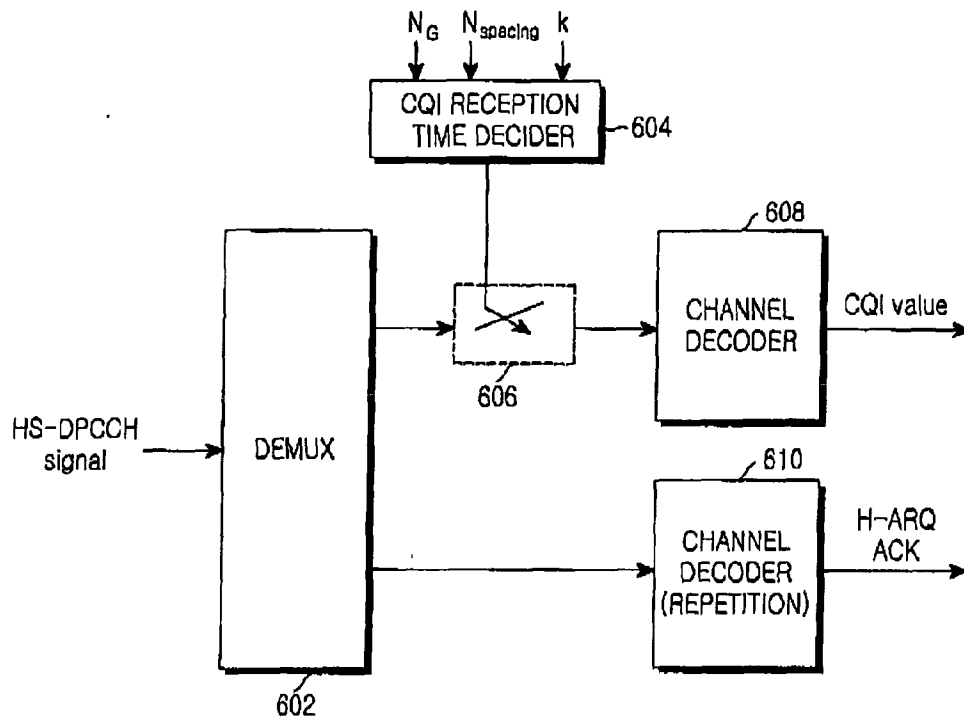

FIG. 7

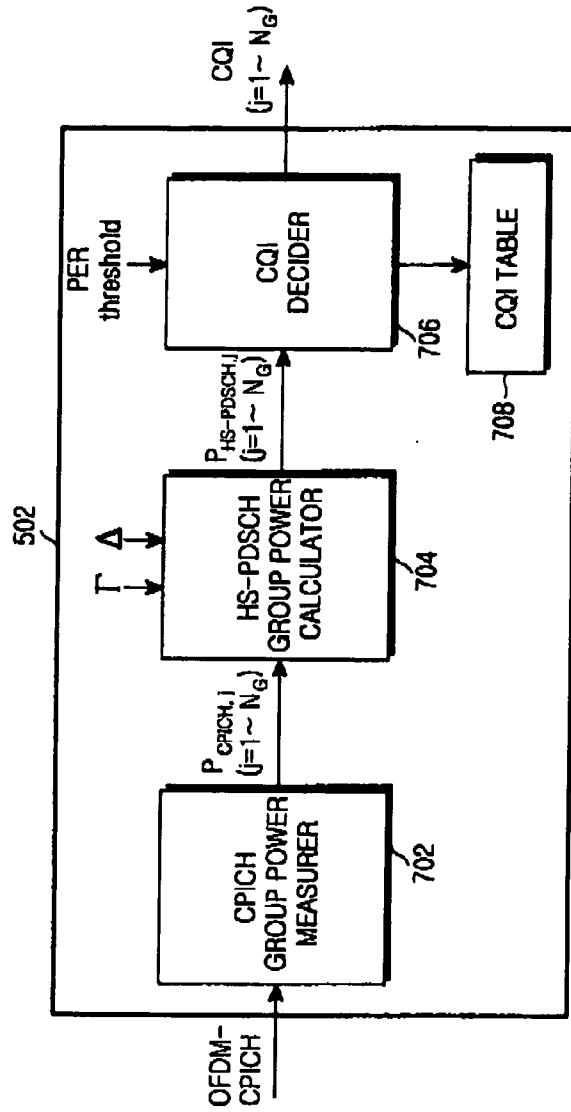

FIG.8



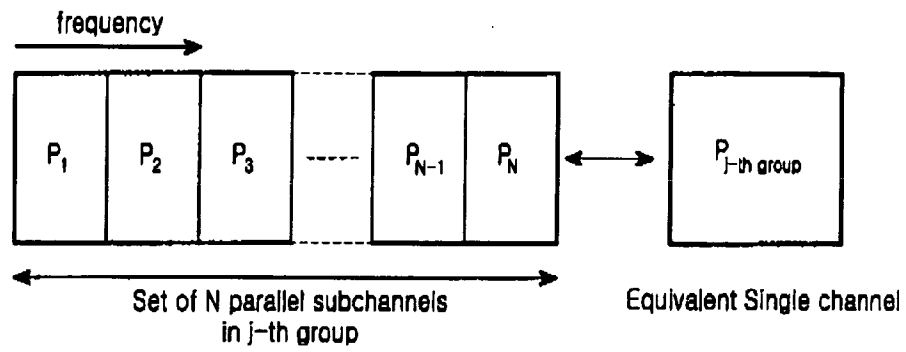

FIG.9

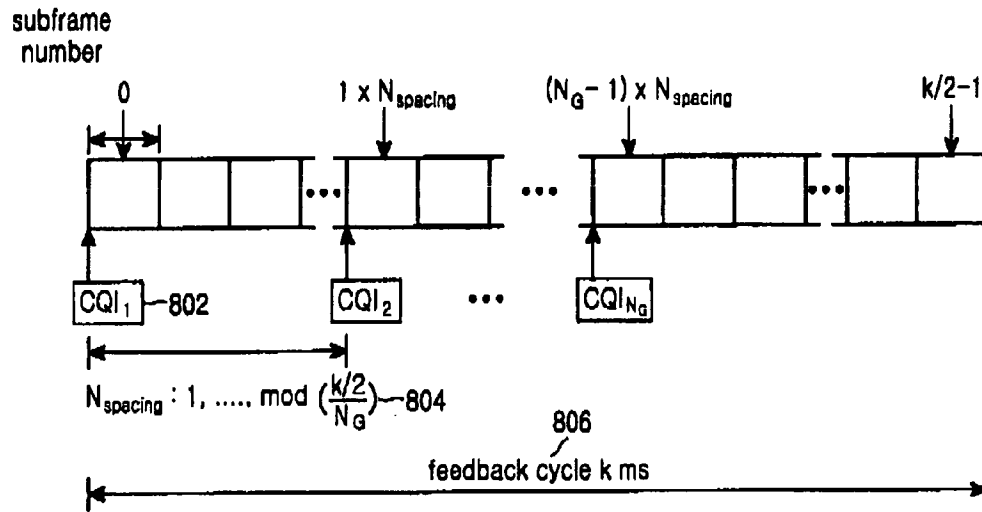
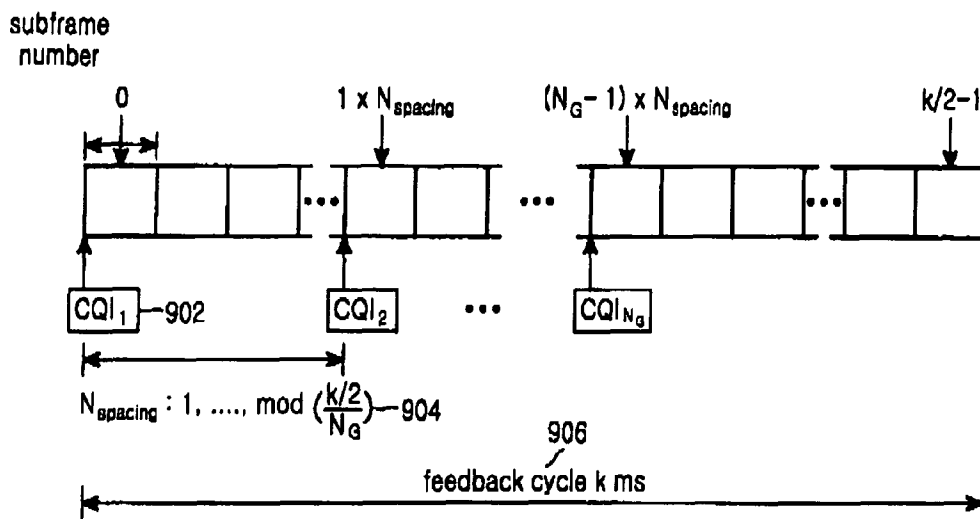

FIG. 10



ex)  $N_G = 6, k = 40\text{ms}$   
 $\rightarrow N_{spacing} = 1, 2, 3$

$N_{spacing}$	CQI timing frame index
1	{ 0, 1, 2, 3, 4, 5 }
2	{ 0, 2, 4, 6, 8, 10 }
3	{ 0, 3, 6, 9, 12, 15 }

FIG.11A

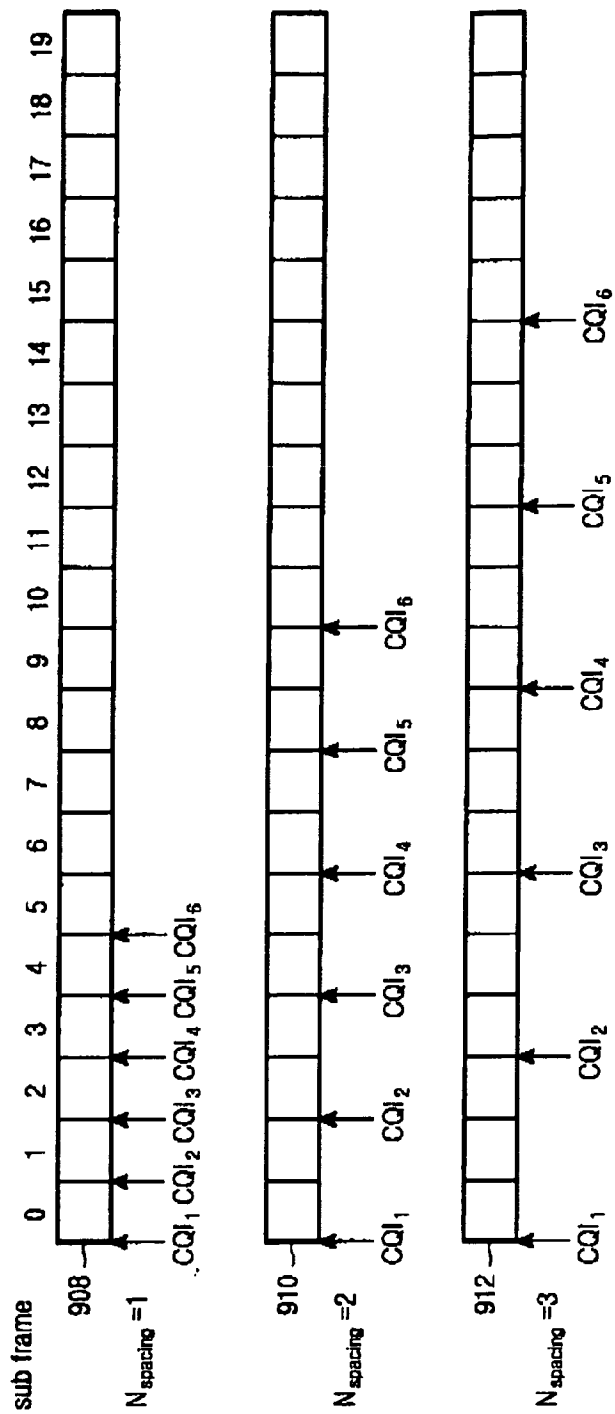

FIG.11B

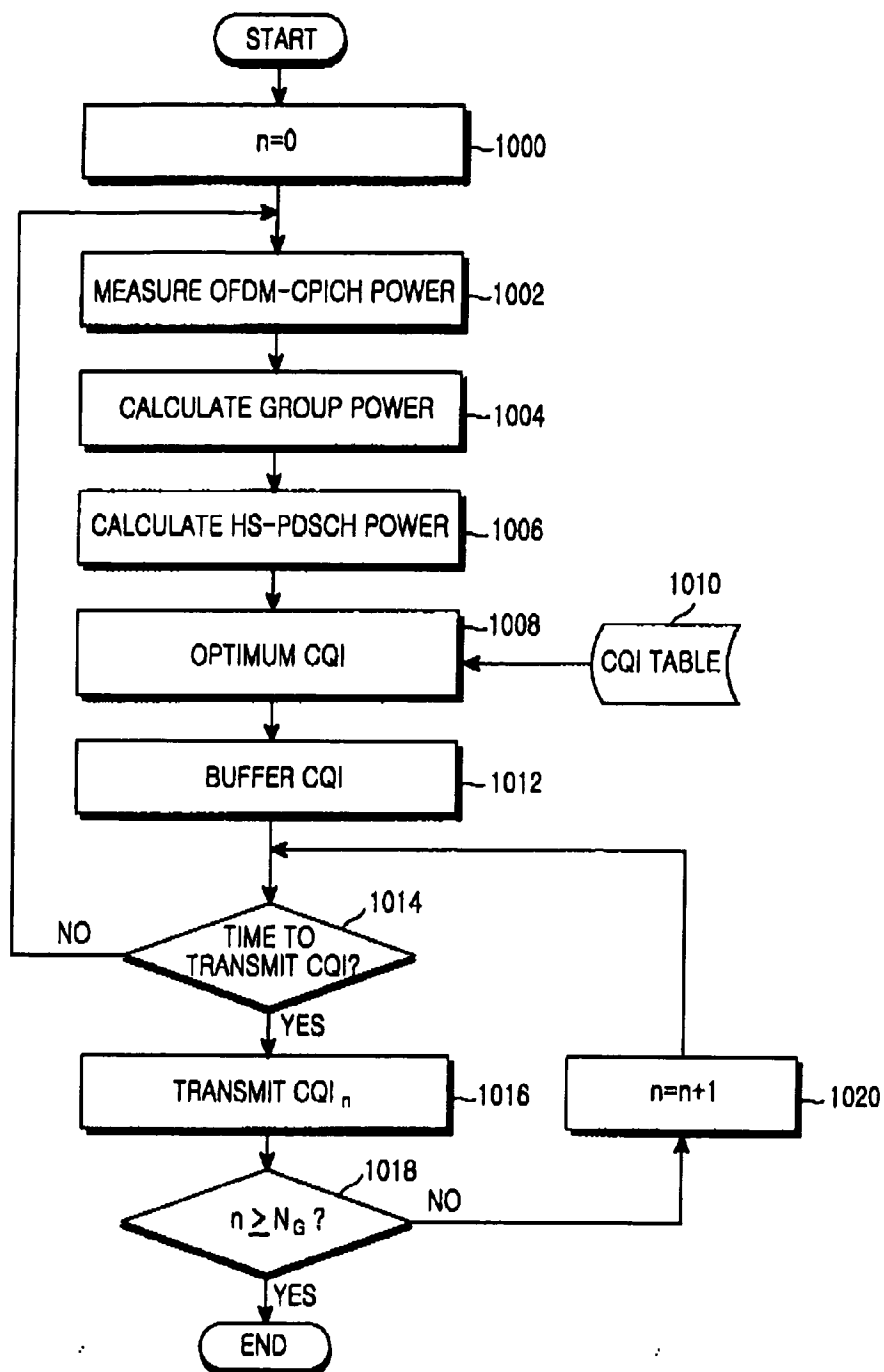

FIG. 12

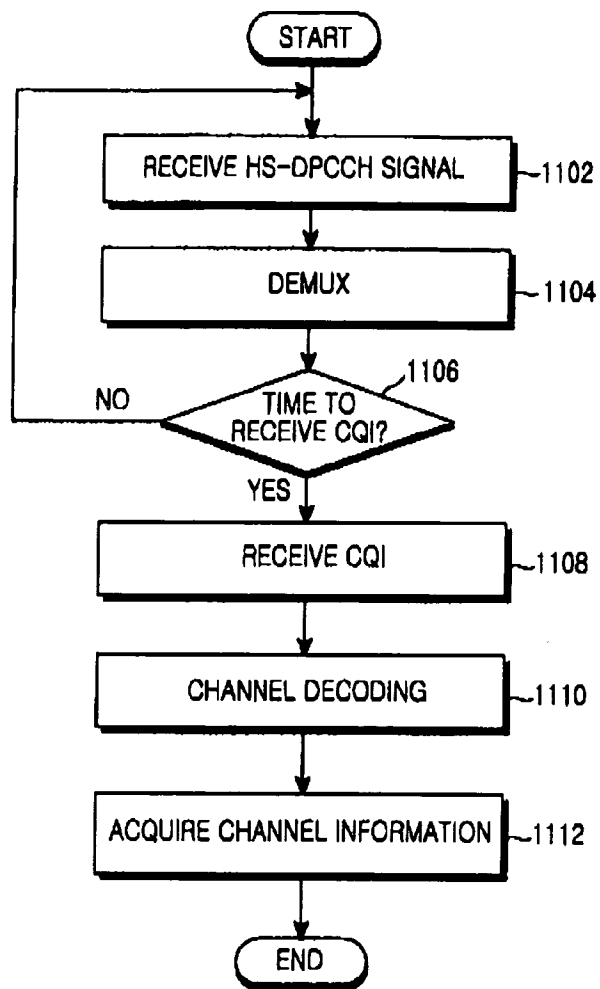

FIG.13

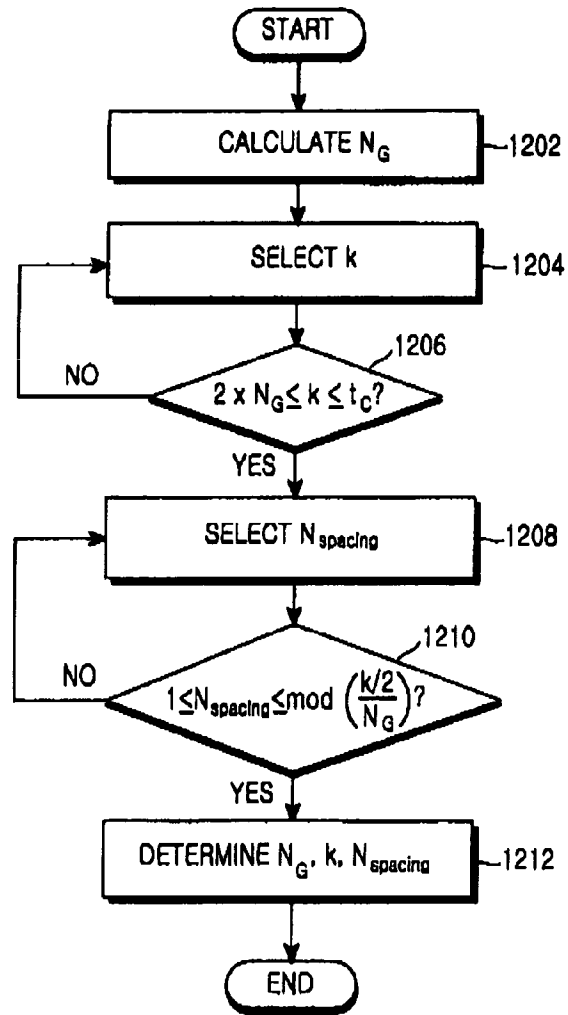

FIG. 14



(11) **EP 1 806 867 A2**

(12) **EUROPEAN PATENT APPLICATION**

(43) Date of publication:  
11.07.2007 Bulletin 2007/28

(51) Int Cl.:  
H04L 1/16 (2006.01) H04B 1/713 (2006.01)  
H04B 7/26 (2006.01) H04J 3/00 (2006.01)  
H04L 27/26 (2006.01)

(21) Application number: 07000358.7

(22) Date of filing: 09.01.2007

(84) Designated Contracting States:  
AT BE BG CH CY CZ DE DK EE ES FI FR GB GR  
HU IE IS IT LI LT LU LV MC NL PL PT RO SE SI  
SK TR

Designated Extension States:  
AL BA HR MK YU

(30) Priority: 09.01.2006 KR 20060002192  
06.04.2006 KR 20060031632

(71) Applicant: Samsung Electronics Co., Ltd.  
Yeongtong-gu  
Suwon-si, Gyeonggi-do (KR)

(72) Inventors:  
• Kwak, Yong-Jun  
Yeongtong-gu  
Suwon-si  
Gyeonggi-do (JP)

- Lee, Ju-Ho  
Yeongtong-gu  
Suwon-si  
Gyeonggi-do (JP)
- Cho, Joon-Young  
Yeongtong-gu  
Suwon-si  
Gyeonggi-do (JP)
- Cho, Yun-Ok  
Yeongtong-gu  
Suwon-si  
Gyeonggi-do (JP)

(74) Representative: Grünecker, Kinkeldey,  
Stockmair & Schwanhäusser  
Anwaltssozietät  
Maximilianstrasse 58  
80538 München (DE)

(54) **Method and apparatus for time multiplexing uplink data and uplink signaling information in a SC-FDMA system**

(57) Provided is a method and an apparatus for transmitting uplink information items having various characteristics by using a single FFT block. The method includes determining if there is uplink signaling information to be transmitted when there is uplink data to be transmitted; time multiplexing the uplink data and a first pilot for the

uplink data and transmitting the multiplexed uplink data and first pilot, when there is no uplink signaling information; and time multiplexing the uplink data, the first pilot for the uplink data, and a second pilot for the uplink data and the uplink signaling information, and transmitting the multiplexed uplink data, first pilot, and second pilot, when there is the uplink signaling information.

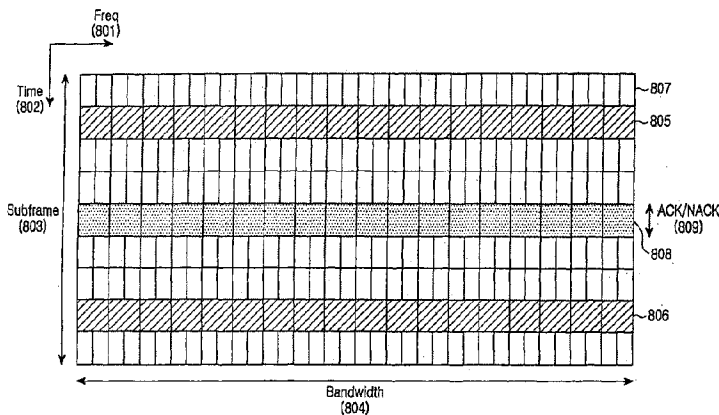

FIG. 8

EP 1 806 867 A2



## EP 1 806 867 A2

## Description

## BACKGROUND OF THE INVENTION

5 1. Field of the Invention

[0001] The present invention relates to a method and an apparatus for transmitting/receiving uplink signaling information and uplink data in a Frequency Division Multiple Access (FDMA) wireless communication system using a single carrier.

10

2. Description of the Related Art

[0002] Recently, active research is being conducted in an Orthogonal Frequency Division Multiplexing (OFDM) scheme or a Single Carrier-Frequency Division Multiple Access (SC-FDMA) scheme similar to the OFDM scheme as a scheme available for high speed data transmission through a wireless channel in a mobile communication system.

15

[0003] The OFDM scheme, which transmits data using multiple carriers, is a special type of a Multiple Carrier Modulation (MCM) scheme in which a serial symbol sequence is converted into parallel symbol sequences, and the parallel symbol sequences are modulated with a plurality of mutually orthogonal subcarriers (or subcarrier channels) before being transmitted.

20

[0004] FIG. 1 is a block diagram illustrating a structure of a transmitter of a typical OFDM system.

[0005] Referring to FIG. 1, the OFDM transmitter includes a channel encoder 101, a modulator 102, a serial-to-parallel converter 103, an Inverse Fast Fourier Transform (IFFT) block or a Digital Fourier Transform (DFT) block 104, a parallel-to-serial converter 105, and a Cyclic Prefix (CP) inserter 106.

25

[0006] The channel encoder 101 receives and channel-encodes an input information bit sequence. In general, a convolutional encoder, a turbo encoder, or a Low Density Parity Check (LDPC) encoder is used as the channel encoder 101. The modulator 102 modulates the channel-encoded bit sequence according to a modulation scheme, such as a Quadrature Phase Shift Keying (QPSK) scheme, 8PSK scheme, 16-ary Quadrature Amplitude Modulation (16QAM) scheme, 64QAM, 256QAM, etc. Although not shown in FIG. 1, it is obvious that a rate matching block for performing repetition and puncturing may be inserted between the channel encoder 101 and the modulator 102.

30

[0007] The serial-to-parallel converter 103 receives output data from the modulator 102 and converts the received data into parallel data. The IFFT block 104 receives the parallel data output from the serial-to-parallel converter 103 and performs an IFFT operation on the parallel data. The data output from the IFFT block 104 is converted to serial data by the parallel-to-serial converter 105. The CP inserter 106 inserts a Cyclic Prefix (CP) into the serial data output from the parallel-to-serial converter 105, thereby generating an OFDM symbol to be transmitted.

35

[0008] The IFFT block 104 converts the input data of the frequency domain to output data of the time domain. In the case of a typical OFDM system, because input data is processed in the frequency domain, a Peak to Average Power Ratio (PAPR) of the data may increase when the data has been converted into the time domain.

40

[0009] The PAPR is one of the most important factors to be considered in the uplink transmission. As the PAPR increases, the cell coverage decreases, so that the signal power required by a User Equipment (UE) increases. Therefore, it is necessary to first reduce the PAPR, and it is thus possible to use an SC-FDMA scheme, which is a scheme modified from the typical OFDM scheme, for the OFDM-based uplink transmission. It is possible to effectively reduce the PAPR by enabling processing in the time domain without performing processing (channel encoding, modulation, etc.) of data in the frequency domain.

45

[0010] FIG. 2 is a block diagram illustrating a structure of a transmitter in a system employing an SC-FDMA scheme, which is a typical uplink transmission scheme.

[0011] Referring to FIG. 2, the SC-FDMA transmitter includes a channel encoder 201, a modulator 202, a serial-to-parallel converter 203, a Fast Fourier Transform (FFT) block 204, a sub-carrier mapper 205, an IFFT block 206, a parallel-to-serial converter 207, and a CP inserter 208.

50

[0012] The channel encoder 201 receives and channel-encodes an input information bit sequence. The modulator 202 modulates the output of the channel encoder 201 according to a modulation scheme, such as a QPSK scheme, an 8PSK scheme, a 16QAM scheme, a 64QAM scheme, a 256QAM scheme, etc. A rate matching block (not shown) may be included between the channel encoder 201 and the modulator 202.

55

[0013] The serial-to-parallel converter 203 receives data output from the modulator 202 and converts the received data into parallel data. The FFT block 204 performs an FFT operation on the data output from the serial-to-parallel converter 203, thereby converting the data into data of the frequency domain. The sub-carrier mapper 205 maps the output data of the FFT block 204 to the input of the IFFT block 206. The IFFT block 206 performs an IFFT operation on the data output from the sub-carrier mapper 205. The output data of the IFFT block 206 is converted to parallel data by the parallel-to-serial converter 207. The CP inserter 208 inserts a CP into the parallel data output from the parallel-to-

## EP 1 806 867 A2

serial converter 207, thereby generating an OFDM symbol to be transmitted.

[0014] FIG. 3 is a block diagram illustrating in more detail the structure for resource mapping shown in FIG. 2. Hereinafter, the operation of the sub-carrier mapper 205 will be described with reference to FIG. 3.

[0015] Referring to FIG. 3, data symbols 301 having been subjected to the channel encoding and modulation are input to an FFT block 302. The output of the FFT block 302 is input to an IFFT block 304. At this time, a sub-carrier mapper 303 maps the output data of the FFT block 302 to the input data of the IFFT block 304.

[0016] The sub-carrier mapper 303 maps the information symbols of the frequency domain data converted by the FFT block 302 to corresponding input points or input taps of the IFFT block 304 so that the information symbols can be carried by proper sub-carriers.

[0017] During the mapping procedure, if the output symbols of the FFT block 302 are sequentially mapped to neighboring input points of the IFFT block 304, the output symbols are transmitted by sub-carriers that are consecutive in the frequency domain. This mapping scheme is referred to as a Localized Frequency Division Multiple Access (LFDMA) scheme.

[0018] Further, when the output symbols of the FFT block 302 are mapped to input points of the IFFT block 304 having a predetermined interval between them, the output symbols are transmitted by sub-carriers having equal intervals between them in the frequency domain. This mapping scheme is referred to as either an Interleaved Frequency Division Multiple Access (IFDMA) scheme or a Distributed Frequency Division Multiple Access (DFDMA) scheme.

[0019] Although FIGs. 2 and 3 show one method of implementing the SC-FDMA technology in the frequency domain, it is also possible to use various other methods, such as a method of implementing the technology in the time domain.

[0020] Diagrams (a) and (b) of FIG. 4 illustrates comparison between the positions of sub-carriers used for the DFDMA and the LFDMA in the frequency domain.

[0021] Referring to diagram (a) of FIG. 4, the transmission symbols of a UE using the DFDMA scheme are distributed with equal intervals over the entire frequency domain (that is, the system band). Referring to diagram (b) of FIG. 4, the transmission symbols of a UE using the LFDMA scheme are consecutively located at some part of the frequency domain.

[0022] According to the LFDMA scheme, because consecutive parts of the entire frequency band are used, it is possible to obtain a frequency scheduling gain by selecting a partial frequency band having good channel gain in the frequency selective channel environment in which severe channel change of frequency bands occurs. In contrast, according to the DFDMA scheme, it is possible to obtain a frequency diversity gain as transmission symbols have various channel gains by using a large number of sub-carriers distributed over a wide frequency band.

[0023] In order to maintain the characteristic of the single carrier as described above, simultaneously transmitted information symbols should be mapped to the IFFT block such that they can always satisfy the LFDMA or DFDMA after passing through a single FFT block (or DFT block).

[0024] In an actual communication system, various information symbols may be transmitted. For example, in the uplink of a Long Term Evolution (LTE) system using the SC-FDMA based on a Universal Mobile Telecommunications System (UMTS), uplink data, control information regulating a transport scheme of the uplink data (which includes Transport Format (TF) information of the uplink data and/or Hybrid Automatic Repeat reQuest (HARQ) information), ACK/NACK for an HARQ operation for downlink data, Channel Quality Indication (CQI) information indicating the channel status reported to be used for scheduling of a node B, etc. may be transmitted. These enumerated information items have different transmission characteristics.

[0025] Uplink data can be transmitted in a situation in which a UE has data in a transmission buffer of the UE and has received permission for uplink transmission from a node B. The control information regulating the transport scheme of the uplink data is transmitted only when the uplink data is transmitted. Sometimes, uplink data may be transmitted without transmission of control information. In contrast, the ACK/NACK, which is transmitted in response to downlink data, has no relation to the transmission of the uplink data. That is, either both the uplink data and the ACK/NACK may be simultaneously transmitted or only one of them may be transmitted. Further, the CQI, which is transmitted at a given time, also has no relation to the transmission of the uplink data. That is, either both the uplink data and the CQI may be simultaneously transmitted or only one of them may be transmitted.

[0026] As described above, various types of uplink information are transmitted in the SC-FDMA system. Under the restriction of use of a single FFT block, which is a characteristic of the single sub-carrier, it is necessary to effectively control the transmission of information in order to transmit various types of information as described above. That is to say, it is necessary to arrange a specific transmission rule for each of the cases where only uplink data is transmitted, where only ACK/NACK or CQI is transmitted, and where both uplink data and uplink signaling information (ACK/NACK or CQI) are transmitted.

## SUMMARY OF THE INVENTION

[0027] Accordingly, the present invention has been made to solve the above-mentioned problems occurring in the prior art, and provides a method and an apparatus for transmitting various types of uplink information having various

## EP 1 806 867 A2

characteristics by using a single FFT block.

**[0028]** The present invention also provides a method and an apparatus for time multiplexing uplink data and uplink signaling information.

5 **[0029]** The present invention also provides a method and an apparatus for transmitting an additional pilot signal necessary for the transmission of uplink signaling information.

**[0030]** In order to accomplish this object, there is provided a method for transmitting multiple types of uplink information in a Single Carrier Frequency Division Multiple Access (SC-FDMA) wireless communication system, the method including, when there is uplink data to be transmitted, determining if there is uplink signaling information to be transmitted; when there is no uplink signaling information, time-multiplexing the uplink data and a first pilot for the uplink data and transmitting the multiplexed uplink data and first pilot; and when there exists the uplink signaling information, time-multiplexing the uplink data, the first pilot for the uplink data, and a second pilot for the uplink data and the uplink signaling information, and transmitting the multiplexed uplink data, first pilot, and second pilot.

**[0031]** In accordance with another aspect of the present invention, there is provided an apparatus for transmitting multiple types of uplink information in a Single Carrier Frequency Division Multiple Access (SC-FDMA) wireless communication system, the apparatus including a multiplexer for time multiplexing uplink data and a first pilot for the uplink data when there is uplink data to be transmitted and there is no uplink signaling information, and time multiplexing the uplink data, the first pilot for the uplink data, and a second pilot for the uplink data and the uplink signaling information when there is both the uplink signaling information and the uplink signaling information; and a resource mapper for transmitting an output of the multiplexer after mapping the output of the multiplexer to a frequency resource.

10 **[0032]** In accordance with another aspect of the present invention, there is provided a method for receiving multiple types of uplink information in a Single Carrier Frequency Division Multiple Access (SC-FDMA) wireless communication system, the method including receiving from a UE a radio signal through a frequency resource; time-demultiplexing the radio signal into uplink data related signal, a first pilot, uplink signaling related signal, and a second pilot; channel-compensating the uplink data related signal by using the first pilot; decoding the channel-compensated uplink data related signal and outputting uplink data; channel-compensating the uplink signaling related signal by using the second pilot; and decoding the channel-compensated uplink signaling related signal and outputting uplink signaling information. In accordance with another aspect of the present invention, there is provided an apparatus for receiving multiple types of uplink information in a Single Carrier Frequency Division Multiple Access (SC-FDMA) wireless communication system, the apparatus including a receiver block for receiving from a UE a radio signal through a frequency resource; a first demultiplexer for time-demultiplexing the radio signal into uplink data related signal, a first pilot, uplink signaling related signal, and a second pilot; a first channel estimator/compensator for channel-compensating the uplink data related signal by using the first pilot; a first channel decoder for decoding the channel-compensated uplink data related signal and outputting uplink data; a second channel estimator/compensator for channel-compensating the uplink signaling related signal by using the second pilot; and a second channel decoder for decoding the channel-compensated uplink signaling related signal and outputting uplink signaling information.

#### BRIEF DESCRIPTION OF THE DRAWINGS

15 **[0033]** The above and other objects, features and advantages of the present invention will be more apparent from the following detailed description taken in conjunction with the accompanying drawings, in which:

- FIG. 1 is a block diagram illustrating a structure of a transmitter of a typical OFDM system;
- FIG. 2 is a block diagram illustrating a structure of a transmitter in a system employing an SC-FDMA scheme, which is a typical uplink transmission scheme;
- 45 FIG. 3 is a block diagram illustrating in more detail the structure for resource mapping shown in FIG. 2;
- FIG. 4 is a diagram for comparing the positions of sub-carriers used for the DFDMA and the LFDMA in the frequency domain;
- FIG. 5 illustrates structures of an uplink transmission frame and its sub-frame of an LTE system;
- FIG. 6 illustrates frequency-time resources of an uplink transmission unit in an LTE system;
- 50 FIG. 7 is a signal flow diagram illustrating a process of signal transmission/reception between a node B and a UE;
- FIG. 8 illustrates use of frequency-time resources according to the present invention;
- FIG. 9 illustrate allocation of an additional pilot for uplink signaling information according to the present invention;
- FIG. 10 is a block diagram illustrating a structure of a transmitter according to the present invention;
- FIG. 11 is a block diagram illustrating a structure of a receiver according to the present invention;
- 55 FIG. 12 is a flow diagram of an operation of a transmitter according to the present invention;
- FIG. 13 is a flow diagram of an operation of a receiver according to the present invention;
- FIG. 14 illustrates a structure of a sub-frame including a pilot additionally used for the CQI according to the present invention;

## EP 1 806 867 A2

FIG. 15 is a block diagram illustrating a structure of a transmitter for time-multiplexing data and CQI according to the present invention;

FIG. 16 illustrates a structure of a receiver for receiving a radio signal transmitted by a transmitter according to the present invention;

5 FIG. 17 is a flow diagram of an operation of a transmitter according to the present invention; and

FIG. 18 is a flow diagram of an operation of a receiver according to the present invention.

## DETAILED DESCRIPTION OF THE PREFERRED EMBODIMENT

10 **[0034]** Hereinafter, preferred embodiments of the present invention will be described with reference to the accompanying drawings. In the following description, a detailed description of known functions and configurations incorporated herein will be omitted when it may make the subject matter of the present invention rather unclear. Further, in the following description of the present invention, various specific definitions are provided only to help general understanding of the present invention, and it is apparent to those skilled in the art that the present invention can be implemented without  
15 such definitions.

**[0035]** The present invention multiplexes different types of uplink information, so as to enable transmission of the uplink information, which can satisfy the single carrier characteristic in a wireless communication system using a Single Carrier Frequency Division Multiple Access (SC-FDMA) scheme. The following description discusses multiplexing for uplink transmission of uplink data, control information, ACK/NACK, CQI, etc. in an SC-FDMA wireless communication system. As used herein, the other information except for the uplink data and control information thereof, that is, information including ACK/NACK and CQI, is referred to as "uplink signaling information."  
20

**[0036]** First, a Long Term Evolution (LTE) system, which is being standardized by the 3<sup>rd</sup> Generation Partnership Project (3GPP), is discussed in order to more clearly describe the present invention. The LTE system employs the SC-FDMA for uplink transmission. FIG. 5 illustrates structures of an uplink transmission frame and its sub-frame.

25 **[0037]** In FIG. 5, reference numeral 501 denotes a radio frame, which is an uplink transmission unit and is defined to have a length of 10 ms. One radio frame 501 includes 20 sub-frames 502, each of which has a length of 0.5 ms. Further, each sub-frame 502 includes six Long Blocks (LBs) 503, 505, 506, 507, 508 and 510, two Short Blocks (SBs) 504 and 509, and Cyclic Prefixes (CPs) 511 and 512 located before the blocks. The LBs 503, 505, 506, 507, 508 and 510 carry information except for pilot signals or pilots used as a reference for coherent modulation, and SBs 504 and 509 are used  
30 only to carry the pilots.

**[0038]** FIG. 6 illustrates the sub-frame 502 of FIG. 5 on the time domain and the frequency domain. In FIG. 6, the horizontal axis indicates the frequency domain 601 and the vertical axis indicates the time domain 602. The range of the frequency domain 601 corresponds to the entire frequency band 604 and the range of the time domain 602 corresponds to one sub-frame 603. As noted, the SBs 605 and 606 carry pilots, and the LBs 607 and 608 carry other information  
35 except for the pilots.

**[0039]** As described above, uplink data transmitted according to resource allocation by a node B, control information in relation to the uplink data, ACK/NACK for indicating success or failure in reception of downlink data, CQI for indicating a channel status, scheduling request information, etc. are transmitted by using the uplink resources.

40 **[0040]** Whether to transmit the uplink data is determined according to the scheduling of a node B, and a resource to be used is also determined according to the resource allocation by the node B. The control information transmitted together with the uplink data is also transmitted according to the resources allocated by the node B. In contrast, since the ACK/NACK is generated based on downlink data, the ACK/NACK is transmitted using an uplink resource automatically allocated according to whether or not the downlink data is transmitted, in response to the control channel defining the downlink data or the downlink data channel. Further, since it is usual that the CQI is periodically transmitted, the CQI is  
45 transmitted using a resource determined in advance through setup by higher level signaling.

**[0041]** A process for transmitting multiple types of uplink information will be described with reference to FIG. 7. FIG. 7 illustrates a process of signal transmission/reception between a node B and a UE.

50 **[0042]** Referring to FIG. 7, for communication with the UE 705, the node B 701 may transmit downlink data 704, downlink control information 703 defining a transform format of the downlink data 704, an uplink grant 702 for allocating an uplink resource of the UE according to a result of scheduling, etc. to the UE 705. In contrast, the UE 705 may transmit uplink data 707, and ACK/NACK 706 for supporting an HARQ operation of the downlink data 704 from the node B 701, etc. to the node B 701. Although not shown, the UE 705 may further transmit uplink signaling information such as CQI indicating the channel information. However, the following discussion is mainly based on a case in which ACK/NACK is transmitted as one of a representative uplink signaling information. Of course, control information for the uplink data  
55 may be also transmitted together with the uplink data 707. Further, the following discussion can be applied to not only the ACK/NACK but also other uplink signaling information such as CQI or scheduling request information.

**[0043]** In step 711, the node B 701 transmits downlink control information 708 together with downlink data 709. The control information 708 and the downlink data 709 are transmitted at either exactly the same transmission time or nearly

## EP 1 806 867 A2

similar transmission time. After receiving the downlink control information 708, the UE 705 decodes the downlink data 709 based on the downlink control information 708. Then, the UE 705 informs the node B 701 of if the decoding of the downlink data 709 was successful. Specifically, in step 715, the UE 705 transmits NACK, which implies that the received downlink data has an error.

5 **[0044]** In step 712, the node B 701 transmits the uplink grant 710, which is resource allocation information for uplink transmission of the UE 705. Upon receiving the uplink grant 710, the UE 705 transmits uplink data 714 together with control information through an uplink resource indicated by the uplink grant 710 in step 716.

**[0045]** The radio resource for transmitting the ACK/NACK 706 must be set in advance. Since the ACK/NACK 706 relates to the transmission of the downlink data 704, the ACK/NACK 706 is transmitted by using either an uplink radio resource mapped to the downlink resource used by the downlink control information 703 or an uplink radio resource mapped to the downlink resource used by the downlink data 704. At this time, the mapping of the radio resource corresponding to the ACK/NACK 706 may change according to time, and it is possible to enable the node B to know the channel statuses corresponding to various sub-carriers, that is, corresponding to detailed frequency bands, by changing the sub-carrier(s) carrying the ACK/NACK 706. In contrast, because the uplink data 707 uses an uplink radio resource directly indicated by the uplink grant 702 transmitted in the downlink by the node B 701, the UE 705 recognizes, by using the uplink grant 702, the uplink radio resource to be used for the uplink data 707.

**[0046]** When the NACK 713 and the uplink data 714 are transmitted at different transmission time as in steps 715 and 716, only one type of uplink information is transmitted at each transmission period. Therefore, the UE 705 can maintain without difficulty the single carrier characteristic of the uplink transmission.

20 **[0047]** Upon receiving the NACK 713, the node B 701 retransmits downlink data 717 substantially equal to the downlink data 709 according to the HARQ operation in step 719. In step 719, control information of the retransmitted downlink data 717 is transmitted. In step 721, the UE 705 transmits ACK 720 in response to the retransmitted downlink data 717. Then, the HARQ operation for the downlink data 709 and 717 is terminated. In step 721 also, the UE 705 transmits only the ACK 720 without the uplink data. Therefore, the UE 705 can maintain without difficulty the single carrier characteristic of the uplink transmission.

**[0048]** In contrast, if the node B 701 transmits the downlink control information 730 and the downlink data 731 nearly simultaneously with the uplink grant 732 in steps 733 and 734, the UE 705 uplink transmits the ACK/NACK 736 and the uplink data 735 substantially at the same time in steps 737 and 738. The radio resource for the ACK/NACK 736 is determined based on the downlink data 731 or the downlink control information 730 and the radio resource for the uplink data 735 is determined based on the uplink grant 732, and these radio resources are usually divided by the frequency side within one sub-frame. Therefore, in the case where the UE 705 must simultaneously transmit the uplink data 735 and the ACK/NACK 736, it is impossible to contain the two types of information 735 and 736 in one FFT block and it is thus impossible to satisfy the single carrier characteristic of the uplink transmission.

**[0049]** In the uplink transmission, it should be always possible to transmit the ACK/NACK 706 and the uplink data 707 within each sub-frame for the flexibility of the downlink and uplink transmission. Therefore, according to the present invention, the ACK/NACK (that is, uplink signaling information) and the uplink data are time-multiplexed and transmitted within the same frequency resource, in order to always satisfy the single carrier characteristic of the uplink transmission regardless of the transmission of the ACK/NACK and the uplink data within one sub-frame, which is the minimum transmission unit.

40 **[0050]** FIG. 8 illustrates a sub-frame structure for time-multiplexing the ACK/NACK and uplink data according to the present invention. In FIG. 8, the horizontal axis corresponds to the frequency domain 801, and the vertical axis corresponds to the time domain 802. The range of the frequency domain 801 corresponds to the entire frequency band 804, and the range of the time domain 802 corresponds to one sub-frame 803. As shown, short blocks 805 and 806 carry pilots, and long blocks 807 carry uplink data and control information defining the transform format of the uplink data except for the pilots.

**[0051]** The ACK/NACK is transmitted through a separate resource (ACK/NACK resource) 808 that is temporally discriminated from the resource (data resource) for the uplink data. The length of the time interval for the ACK/NACK may be the same as the size of each short block or the size of each long block, or may be another size. Further, the ACK/NACK resource may be variably determined according to the used frequency band, etc.

50 **[0052]** Referring to FIG. 8, short blocks 805 and 806 carry pilots, which are used in channel estimation for radio resources (data resources) of uplink data transmitted through the long blocks 807. When the ACK/NACK is transmitted at a different time point from that of the uplink data, all of the pilots are used for the uplink data and it is impossible to perform the channel estimation for the radio resource (ACK/NACK resource). If the ACK/NACK is restored according to a non-coherent scheme without channel estimation, the transmission performance is degraded in comparison with the case including the channel estimation.

55 **[0053]** Therefore, according to the present invention, a second pilot for the ACK/NACK having been time-multiplexed with the uplink data within the same sub-frame is used in addition to the first pilot for the uplink data. That is, the present invention additionally uses the second pilot for the ACK/NACK, and frequency hopping may be applied to the second

## EP 1 806 867 A2

pilot to be used in the uplink channel estimation of the node B. It is of course possible to apply such a technology to not only transmission of the ACK/NACK but also transmission of other uplink signaling information.

**[0054]** FIG. 9 illustrates a structure of a sub-frame including the second pilot additionally used for the ACK/NACK according to the present invention. In FIG. 9, the horizontal axis corresponds to the frequency domain 901, and the vertical axis corresponds to the time domain 902. The range of the frequency domain 901 corresponds to the entire frequency band 904, and the range of the time domain 902 corresponds to one sub-frame 903.

**[0055]** As shown, short blocks 905 and 906 carry the first pilots, and long blocks 907 carry uplink data and control information defining the transform format of the uplink data.

**[0056]** The ACK/NACK is transmitted through a separate resource (ACK/NACK resource) 908 that is temporally discriminated from the resource (data resource) for the uplink data. The second pilot for estimation of the channel in relation to the ACK/NACK is transmitted to a time resource 909 just adjacent to the ACK/NACK resource 908, thereby reflecting the channel status of the ACK/NACK. Due to the use of the ACK/NACK and the second pilot, one sub-frame may have five or less long blocks.

**[0057]** FIG. 10 is a block diagram illustrating a structure of a transmitter (UE) for time-multiplexing data and ACK/NACK according to the present invention.

**[0058]** Referring to FIG. 10, when the UE has uplink data to transmit, the uplink data 1002 and the control information 1001 defining the transmit format of the uplink data 1002 are input to channel encoders 1006 and 1007, and are then input to and multiplexed by a multiplexer 1008. The output of the multiplexer 1008 is input to a time multiplexer 1010. Further, a first pilot 1003 for the uplink data 1002 and/or the control information 1001 is input to the time multiplexer 1010.

**[0059]** When there is ACK/NACK 1004 transmitted by the UE for HARQ operation of downlink data, the ACK/NACK 1004 is subjected to encoding, such as repetition encoding, by a channel encoder 1009, and is then input to the time multiplexer 1010. A second pilot for the ACK/NACK 1004 is also input to the time multiplexer 1010.

**[0060]** The time multiplexer 1010 time-multiplexes the four inputs according to a predetermined sub-frame structure (for example, the structure shown in FIG. 9), and a resource mapper 1011 then maps the multiplexed information to a predetermined resource for transmission. The resource mapper 1011 includes an FFT (or DFT) block, a sub-carrier mapper, and an IFFT block, and the outputs of the resource mapper 1011 are transmitted while maintaining equal intervals between them in the frequency domain.

**[0061]** FIG. 11 illustrates a structure of a receiver (node B) for receiving and decoding a radio signal transmitted by the transmitter.

**[0062]** When a receiver block 1101 has received a signal of one sub-frame transmitted by the UE, the received signal is time demultiplexed by a time demultiplexer 1102 according to a predetermined sub-frame structure (for example, the structure shown in FIG. 9). The time demultiplexer 1102 performs an operation inverse to the operation of the resource mapper 1011 of the transmitter. The outputs of the time demultiplexer 1102 include data-related signal 1103, a first pilot 1104 for uplink data, ACK/NACK-related signal 1106, and a second pilot 1107 for the ACK/NACK.

**[0063]** The channel estimator/compensator 1105 performs channel estimation for the data resource by means of the first pilot 1104, and channel-compensates the data-related signal 1103 by means of the channel estimation information. The output of the channel estimator/compensator 1105 is demultiplexed into encoded control information and encoded uplink data by the demultiplexer 1110. The encoded control information and the encoded uplink data are restored to the uplink data 1114 and the control information 1113 by the channel decoders 1111 and 1112.

**[0064]** Further, the channel estimator/compensator 1108 performs channel estimation for the ACK/NACK resource and then performs channel compensation of the ACK/NACK-related signal 1106 by using the channel estimation information. The output of the channel estimator 1108 is decoded by a channel decoder 1115, so that it is restored to the ACK/NACK 1116.

**[0065]** FIG. 12 is a flow diagram illustrating the operation of a transmitter according to the present invention. In the following description, description of the control information for the uplink data is omitted because it is the same as that of the uplink data.

**[0066]** Referring to FIG. 12, the UE determines whether to transmit data in step 1202. Specifically, the UE determines if the UE has data to be transmitted and if there is a data resource available to the UE through scheduling, etc. of a node B. When the determination in step 1202 concludes that there is data to be transmitted, the UE transmits in step 1203 the data after mapping the data to a data resource (907 in FIG. 9), which corresponds to the first time interval of one sub-frame, and then in step 1205 transmits a first pilot for the data after mapping the first pilot to a time resource (905 and 906 in FIG. 9) adjacent to the first time interval.

**[0067]** After the first pilot, the UE determines in step 1206 if it will transmit ACK/NACK for downlink data, based on the HARQ operation for the downlink data and based on if the downlink data has been normally received. If the determination in step 1206 concludes that there is ACK/NACK to be transmitted, the UE transmits in step 1207 the ACK/NACK after mapping the ACK/NACK to an ACK/NACK resource (908 in FIG. 9), which corresponds to a second time interval different from the first time interval, and transmits in step 1208 the second pilot for the ACK/NACK after mapping the second pilot to a time resource (909 in FIG. 9) adjacent to the second time interval. If the determination in step 1206

## EP 1 806 867 A2

concludes that there is no ACK/NACK to be transmitted, no information is transmitted in the second time interval at all.

**[0068]** When the determination in step 1202 concludes that there is no data to be transmitted, the UE determines in step 1204 if there is ACK/NACK to be transmitted. When there is ACK/NACK to be transmitted, the UE transmits in step 1209 the ACK/NACK in the second time interval and transmits in step 1210 the second pilot for the ACK/NACK through the time resource adjacent to the second time interval. In this case, no information is transmitted in the first time interval at all. When there is no ACK/NACK or other uplink signaling information, the operation for the current sub-frame is terminated.

**[0069]** FIG. 13 is a flow diagram of an operation of a receiver according to the present invention. In the following description, description of the control information for the uplink data is omitted because it is the same as that of the uplink data.

**[0070]** Referring to FIG. 13, the node B determines if there is data to receive in step 1302. Specifically, the node B determines if the node B has allocated a data resource to the UE through scheduling, etc. When the determination in step 1302 concludes that there is data to be received, the node B in step 1303 extracts the first pilot from a predetermined time resource block (905 and 906 in FIG. 9) of a received signal during one sub-frame and performs channel estimation of the data resource (the first time interval, 907 in FIG. 9) included in the received signal by using the first pilot. Then, in step 1304, the node B extracts data-related signal corresponding to the first time interval of the received signal, and obtains the data by channel-compensating the data-related signal by using channel estimation information obtained based on the first pilot.

**[0071]** After obtaining the data, the node B determines in step 1305 if the received signal includes ACK/NACK, based on if a resource has been allocated at a previous transmission time point. When the received signal includes ACK/NACK, the node B in step 1306 extracts the second pilot from a predetermined time resource block (909 in FIG. 9), and performs channel estimation of the ACK/NACK resource (that is, the second time interval 908 in FIG. 9) of the received signal by using the second pilot. In step 1307, the node B extracts ACK/NACK-related signal corresponding to the second time interval of the received signal, and obtains the ACK/NACK by channel-compensating the ACK/NACK-related signal by using the channel estimation information obtained from the second pilot.

**[0072]** Meanwhile, when the determination in step 1302 concludes that there is no data to be received, the node B determines in step 1308 if there is ACK/NACK to receive. When there is ACK/NACK to receive, the node B in step 1309 extracts the second pilot from the predetermined time resource block of the received signal and performs channel estimation of the ACK/NACK resource (the second time interval) of the received signal by using the second pilot. In step 1310, the node B extracts ACK/NACK-related signal corresponding to the second time interval of the received signal, and obtains the ACK/NACK by channel-compensating the ACK/NACK-related signal by using the channel estimation information obtained from the second pilot.

**[0073]** Another preferred embodiment of the present invention discussed below considers a case of using a second pilot for the CQI in addition to the first pilot for the uplink data in a situation in which uplink data and the CQI, which is uplink signaling information, are time-multiplexed within a sub-frame. The second pilot for the CQI may be used when the node B additionally determines the uplink channel status and performs uplink scheduling. Therefore, when the second pilot is transmitted by using different sub-carriers at each transmission period instead of always using the same sub-carrier, the node B can obtain a more detailed uplink channel status according to the sub-carriers.

**[0074]** This embodiment provides a scheme of changing sub-carriers carrying the second pilot according to transmission time points for the above-mentioned purpose, that is a scheme for applying frequency hopping. To this end, the frequency hopping is also applied to the CQI. It goes without saying that the frequency hopping transmission of the CQI and a corresponding pilot proposed by the present embodiment can be applied to the transmission of other uplink signaling information as well as the CQI.

**[0075]** FIG. 14 illustrates a structure of a sub-frame including the second pilot additionally used for the CQI according to an embodiment of the present invention. In FIG. 14, the horizontal axis corresponds to the frequency domain 1401, and the vertical axis corresponds to the time domain 1402. The range of the frequency domain 1401 corresponds to the entire frequency band 1404, and the range of the time domain 1402 corresponds to one sub-frame 1403.

**[0076]** As shown, short blocks 1405 and 1406 carry the first pilots for uplink data, and long blocks 1407 carry the uplink data and control information defining the transform format of the uplink data.

**[0077]** The CQI is transmitted through a separate resource (CQI resource) 1408 that is temporally discriminated from the resource (data resource) for the uplink data. The second pilot for estimation of the channel in relation to the CQI is transmitted to a time resource 1409 just adjacent to the CQI resource 1408, thereby reflecting the channel status of the CQI. Due to the use of the CQI and the second pilot, one sub-frame may have five or less long blocks.

**[0078]** During one sub-frame, the CQI and the second pilot are transmitted by a sub-carrier set including a part of the sub-carriers in the entire frequency band 1404, and the CQI and the second pilot are carried by the same sub-carrier (s). At this time, the second pilot is transmitted according to a distributed transmission scheme, so as to inform the node B of the uplink channel quality for the UE. By using the distributed transmission scheme, it is possible to additionally obtain a frequency diversity effect.

## EP 1 806 867 A2

**[0079]** FIG. 15 is a block diagram illustrating a structure of a transmitter (UE) for time multiplexing data and CQI according to an embodiment of the present invention.

**[0080]** Referring to FIG. 15, when the UE has uplink data to transmit, the uplink data 1502 and the control information 1501 defining the transmit format of the uplink data 1502 are input to channel encoders 1506 and 1507, and are then input to and multiplexed by a multiplexer 1508. The output of the multiplexer 1508 is input to a time multiplexer 1510. Further, a first pilot 1503 for the uplink data 1502 and/or the control information 1501 is input to the time multiplexer 1510.

**[0081]** When there is CQI 1504 transmitted by the UE for downlink scheduling, the CQI 1504 is subjected to encoding, such as repetition encoding, by a channel encoder 1509, and is then input to the time multiplexer 1510. A second pilot for the CQI 1504 is also input to the time multiplexer 1510.

**[0082]** The time multiplexer 1510 time-multiplexes the four inputs according to a predetermined sub-frame structure (for example, the structure shown in FIG. 14), and a resource mapper 1511 then transmits the multiplexed information after mapping the multiplexed information to a predetermined resource. By the resource mapper 1511, the CQI 1504 and the second pilot 1505 are mapped to the same sub-carrier (or sub-carrier group). At this time, the CQI 1504 and the second pilot 1505 are mapped to a sub-carrier (or sub-carrier group), which changes according to time by determination of a hopping controller 1513. The frequency hopping as described above is also applied to the second pilot, and the UE can inform the node B of the uplink channel quality in more detail by the frequency hopping of the second pilot 1505. For example, the frequency hopping may be performed according to a time function as defined by Equation (1) below.

$$SC\_i = F(\text{frame\_num}, \text{sub\_frame\_num}, \text{symbol\_num}, \text{Seed}) \dots\dots (1)$$

**[0083]** In Equation (1),  $SC\_i$  denotes an index of a sub-carrier set to which the CQI and the second pilot are mapped,  $\text{frame\_num}$  denotes a frame number,  $\text{sub\_frame\_num}$  denotes a sub-frame number within the frame,  $\text{symbol\_num}$  denotes a symbol number within the sub-frame, and  $\text{Seed}$  denotes a predetermined reference value. Further,  $F()$  denotes a predetermined function in the system.

**[0084]** In FIG. 15, The resource mapper 1511 includes an FFT (or DFT) block, a sub-carrier mapper, and an IFFT block, as described above with reference to FIG. 2, and the outputs (frequency components) of the resource mapper 1511 are transmitted while maintaining equal intervals (0 or above) between them in the frequency domain.

**[0085]** FIG. 16 illustrates a structure of a receiver (node B) for receiving and decoding a radio signal transmitted by the transmitter.

**[0086]** When a receiver block 1601 has received a signal of one sub-frame transmitted by the UE, the received signal is time demultiplexed by a time demultiplexer 1602 according to a predetermined sub-frame structure (for example, the structure shown in FIG. 14). The time demultiplexer 1602 performs an operation inverse to the operation of the resource mapper 1511 of the transmitter. The outputs of the time demultiplexer 1602 include data-related signal 1603, a first pilot 1604 for uplink data, CQI-related signal 1606, and a second pilot 1607 for the CQI.

**[0087]** The time demultiplexer 1602 performs frequency hopping for the CQI 1606 and the second pilot 1607, and the hopping controller 1617 controls the time demultiplexer 1602. That is, the time demultiplexer 1602 detects a sub-carrier group determined at each transmission time point by the hopping controller 1617, and detects the CQI-related signal 1606 and the second pilot 1607 from the detected sub-carrier group.

**[0088]** The channel estimator/compensator 1605 performs channel estimation for the data resource by means of the first pilot 1604, and channel-compensates the data-related signal 1603 by means of the channel estimation information. The output of the channel estimator/compensator 1605 is demultiplexed into encoded control information and encoded uplink data by the demultiplexer 1610. The encoded control information and the encoded uplink data are restored to the uplink data 1614 and the control information 1613 by the channel decoders 1611 and 1612.

**[0089]** The channel estimator/compensator 1608 performs channel estimation for the CQI resource and then performs channel compensation of the CQI-related signal 1606 by using the channel estimation information. The output of the channel estimator 1608 is decoded by a channel decoder 1615, so that it is restored to the CQI 1616.

**[0090]** FIG. 17 is a flow diagram illustrating the operation of a transmitter according to an embodiment of the present invention. In the following description, description of the control information for the uplink data is omitted because it is the same as that of the uplink data.

**[0091]** Referring to FIG. 17, the UE determines whether to transmit data in step 1702. Specifically, the UE determines if the UE has data to be transmitted and if there is a data resource allocated to the UE through scheduling, etc. of a node B. When the determination in step 1702 concludes that there is data to be transmitted, the UE in step 1703 transmits the data after mapping the data to a data resource (1407 in FIG. 14), which corresponds to the first time interval of one sub-frame, , and then in step 1705 transmits a first pilot for the data after mapping the first pilot to a time resource (1405 and 1406 in FIG. 14) adjacent to the first time interval.



## EP 1 806 867 A2

**[0092]** After transmitting the first pilot, the UE determines in step 1706 if it will transmit CQI for downlink data, based on a predetermined CQI period. If the determination in step 1706 concludes that there is CQI to be transmitted, the UE in step 1707 transmits the CQI after mapping the CQI to a CQI resource (1408 in FIG. 14), which corresponds to a second time interval different from the first time interval, and in step 1708 transmits the second pilot for the CQI after mapping the second pilot to a time resource (1409 in FIG. 14) adjacent to the second time interval. If the determination in step 1706 concludes that there is no CQI to be transmitted, no information is transmitted in the second time interval at all.

**[0093]** When the determination in step 1702 concludes that there is no data to be transmitted, the UE in step 1709 determines in step 1704 if there is CQI to be transmitted. When there is CQI to be transmitted, the UE transmits the CQI in the second time interval and in step 1710 transmits the second pilot for the CQI through the time resource adjacent to the second time interval. In this case, no information is transmitted in the first time interval at all. When there is no CQI to be transmitted or other uplink signaling information, the operation for the current sub-frame is terminated.

**[0094]** FIG. 18 is a flow diagram of an operation of a receiver according to an embodiment of the present invention. In the following description, a description of the control information for the uplink data is omitted because it is the same as that of the uplink data.

**[0095]** Referring to FIG. 18, the node B determines if there is data to receive in step 1802. Specifically, the node B determines if the node B has allocated a data resource to the UE through scheduling, etc. When the determination in step 1802 concludes that there is data to be received, the node B in step 1803 extracts the first pilot from a predetermined time resource block (1405 and 1406 in FIG. 14) of a received signal during one sub-frame and performs channel estimation of the data resource (the first time interval, 1407 in FIG. 14) included in the received signal by using the first pilot. Then, in step 1804, the node B extracts data-related signal corresponding to the first time interval of the received signal, and obtains the data by channel-compensating the data-related signal by using channel estimation information obtained based on the first pilot.

**[0096]** After obtaining the data, the node B determines in step 1805 if the received signal includes CQI, according to the predetermined CQI period. When the received signal includes CQI, the node B in step 1812 determines the position of the frequency resource for reading the CQI and the second pilot through frequency hopping of the CQI and the second pilot, and extracts the second pilot from a predetermined time resource block (1409 in FIG. 14) of the determined frequency domain and in step 1806 performs channel estimation of the CQI resource (that is, the second time interval 1408 in FIG. 14) of the received signal by using the second pilot.

**[0097]** In step 1806, the node B recognizes the uplink channel quality from the second pilot and uses the information of uplink channel quality in uplink scheduling. That is, the node B can determine the reception reliability of the CQI based on the channel quality of the CQI resource, can determine the uplink channel quality from the reception reliability of the CQI, and can use the uplink channel quality in uplink scheduling.

**[0098]** Then, in step 1807, the node B extracts CQI-related signal from the second time interval of the received signal, and channel-compensates the extracted CQI-related signal by using the CQI-related signal obtained from the second pilot, thereby obtaining the CQI. The CQI can be used in uplink scheduling.

**[0099]** Meanwhile, when the determination in step 1802 concludes that there is no data to be received, the node B determines in step 1808 if there is CQI to receive. When there is CQI to receive, the node B in step 1813 determines the position of the frequency resource for reading the CQI and the second pilot through frequency hopping of the CQI and the second pilot, and extracts the second pilot from a predetermined time resource block of the determined frequency domain and in step 1809 performs channel estimation of the CQI resource (that is, the second time interval) of the received signal by using the second pilot. Then, in step 1810, the node B extracts CQI-related signal from the second time interval of the received signal, and channel-compensates the extracted CQI-related signal by using the CQI-related signal obtained from the second pilot, thereby obtaining the CQI.

**[0100]** The present invention presents schemes for multiplexing and resource mapping of uplink data and uplink signaling information, in order to satisfy the single sub-carrier characteristic in transmission of the uplink data and uplink signaling information in a Single Carrier Frequency Division Multiple Access (SC-FDMA) wireless communication system. The present invention provides a time multiplexing scheme and a pilot structure thereof, which can eliminate factors disturbing the single carrier transmission requirement and prevent PAPR increase, which may occur when uplink data and uplink signaling information such as ACK/NACK and CQI are transmitted without relation to each other. Further, the present invention provides a scheme for frequency hopping of the uplink control information and the pilot, in order to enhance the performance of the channel estimation by using an additional pilot.

**[0101]** While the invention has been shown and described with reference to certain preferred embodiments thereof, it will be understood by those skilled in the art that various changes in form and details may be made therein without departing from the spirit and scope of the invention as defined by the appended claims.

55

## EP 1 806 867 A2

## Claims

- 5
1. A method for transmitting multiple types of uplink information in a Single Carrier Frequency Division Multiple Access (SC-FDMA) wireless communication system, the method comprising the steps of:
- when there is uplink data to be transmitted, determining if there is uplink signaling information to be transmitted; when there is no uplink signaling information, time-multiplexing the uplink data and a first pilot for the uplink data and transmitting the multiplexed uplink data and first pilot; and
- 10 when there exists the uplink signaling information, time-multiplexing the uplink data, the first pilot for the uplink data, and a second pilot for the uplink data and the uplink signaling information, and transmitting the multiplexed uplink data, first pilot, and second pilot.
2. The method as claimed in claim 1, wherein the second pilot is transmitted temporally adjacent to the uplink signaling information.
- 15
3. The method as claimed in claim 1, further comprising performing frequency hopping in order to determine a position of a sub-carrier set within the frequency resource, wherein the sub-carrier set is used to carry both the uplink signaling information and the second pilot.
- 20
4. The method as claimed in claim 1, wherein the uplink signaling information comprises at least one of a Channel Quality Indicator (CQI), which periodically occurs in order to indicate a status of a channel, a ACK/NACK, which indicates success or failure in reception of downlink data, and scheduling request information.
- 25
5. An apparatus for transmitting multiple types of uplink information in a Single Carrier Frequency Division Multiple Access (SC-FDMA) wireless communication system, the apparatus comprising:
- a multiplexer for time multiplexing uplink data and a first pilot for the uplink data when there is uplink data to be transmitted and there is no uplink signaling information, and time multiplexing the uplink data, the first pilot for the uplink data, and a second pilot for the uplink data and the uplink signaling information when there is both
- 30 the uplink signaling information and the uplink signaling information; and
- a resource mapper for transmitting an output of the multiplexer after mapping the output of the multiplexer to a frequency resource.
6. The apparatus as claimed in claim 5, wherein the second pilot is transmitted temporally adjacent to the uplink signaling information.
- 35
7. The apparatus as claimed in claim 5, further comprising a hopping controller for performing frequency hopping in order to determine a position of a sub-carrier set within the frequency resource, wherein the sub-carrier set is used to carry both the uplink signaling information and the second pilot.
- 40
8. The apparatus as claimed in claim 5, wherein the uplink signaling information includes at least one of a Channel Quality Indicator (CQI), which periodically occurs in order to indicate a status of a channel, a ACK/NACK, which indicates success or failure in reception of downlink data, and scheduling request information.
- 45
9. A method for receiving multiple types of uplink information in a Single Carrier Frequency Division Multiple Access (SC-FDMA) wireless communication system, the method comprising the steps of:
- receiving from an user equipment (UE) a radio signal through a frequency resource;
- 50 time-demultiplexing the radio signal into uplink data-related signal, a first pilot, uplink signaling-related signal, and a second pilot;
- channel-compensating the uplink data-related signal by using the first pilot;
- decoding the channel-compensated uplink data-related signal and outputting uplink data;
- channel-compensating the uplink signaling-related signal by using the second pilot; and
- 55 decoding the channel-compensated uplink signaling-related signal and outputting uplink signaling information.
10. The method as claimed in claim 9, wherein the second pilot is received temporally adjacent to the uplink signaling information.

**EP 1 806 867 A2**

11. The method as claimed in claim 9, further comprising performing frequency hopping in order to determine a position of a sub-carrier set within the frequency resource, wherein the sub-carrier set is used to read the uplink signaling information and the second pilot.
- 5 12. The method as claimed in claim 9, wherein the uplink signaling information comprises at least one of a Channel Quality Indicator (CQI), which periodically occurs in order to indicate a status of a channel, a ACK/NACK, which indicates success or failure in reception of downlink data, and scheduling request information.
- 10 13. An apparatus for receiving multiple types of uplink information in a Single Carrier Frequency Division Multiple Access (SC-FDMA) wireless communication system, the apparatus comprising:
- a receiver block for receiving from an user equipment (UE) a radio signal through a frequency resource;
  - a first demultiplexer for time-demultiplexing the radio signal into uplink data-related signal, a first pilot, uplink signaling-related signal, and a second pilot;
  - 15 a first channel estimator/compensator for channel-compensating the uplink data-related signal by using the first pilot;
  - a first channel decoder for decoding the channel-compensated uplink data-related signal and outputting uplink data;
  - a second channel estimator/compensator for channel-compensating the uplink signaling-related signal by using the second pilot; and
  - 20 a second channel decoder for decoding the channel-compensated uplink signaling-related signal and outputting uplink signaling information.
14. The apparatus as claimed in claim 13, wherein the second pilot is received temporally adjacent to the uplink signaling information.
- 25 15. The apparatus as claimed in claim 13, further comprising a hopping controller for controlling the first demultiplexer by performing frequency hopping in order to determine a position of a sub-carrier set within the frequency resource, wherein the sub-carrier set is used to read the uplink signaling information and the second pilot.
- 30 16. The apparatus as claimed in claim 13, wherein the uplink signaling information comprises at least one of a Channel Quality Indicator (CQI), which periodically occurs in order to indicate a status of a channel, a ACK/NACK, which indicates success or failure in reception of downlink data, and scheduling request information.

35

40

45

50

55

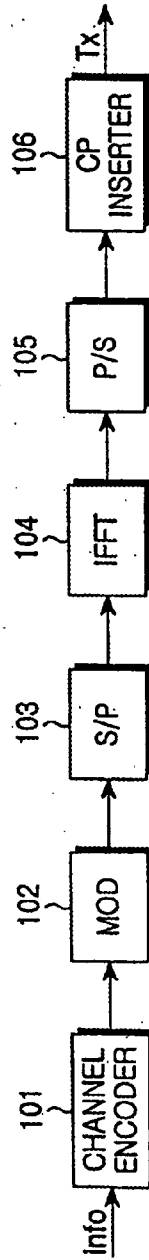

FIG.1

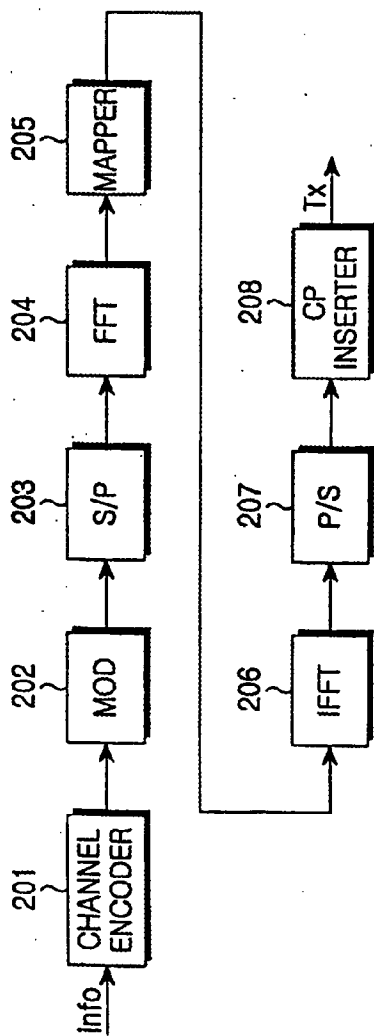

FIG.2

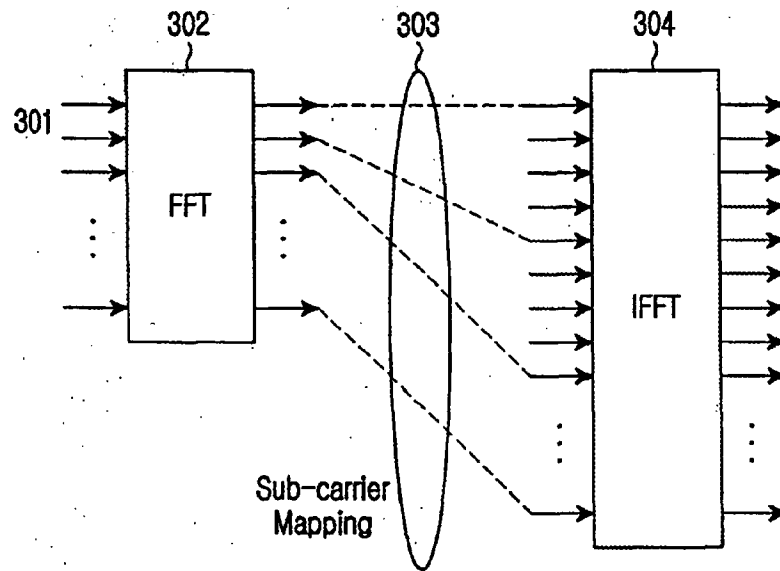
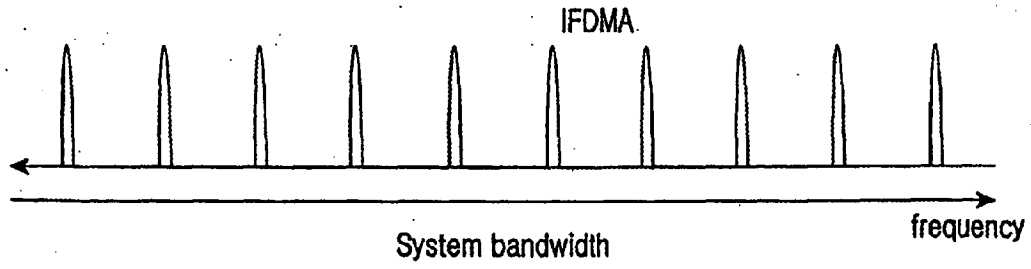
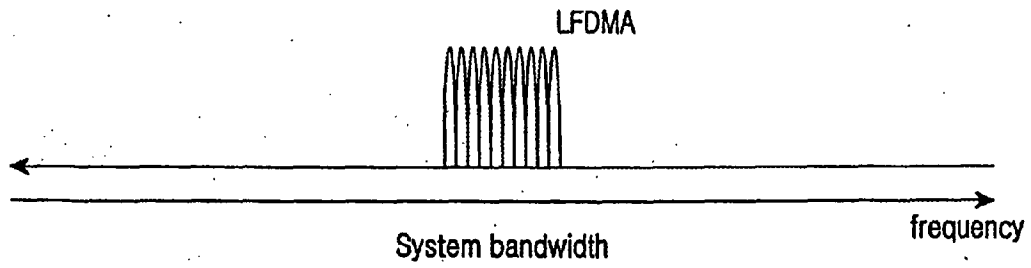

FIG.3



(a)



(b)

FIG.4

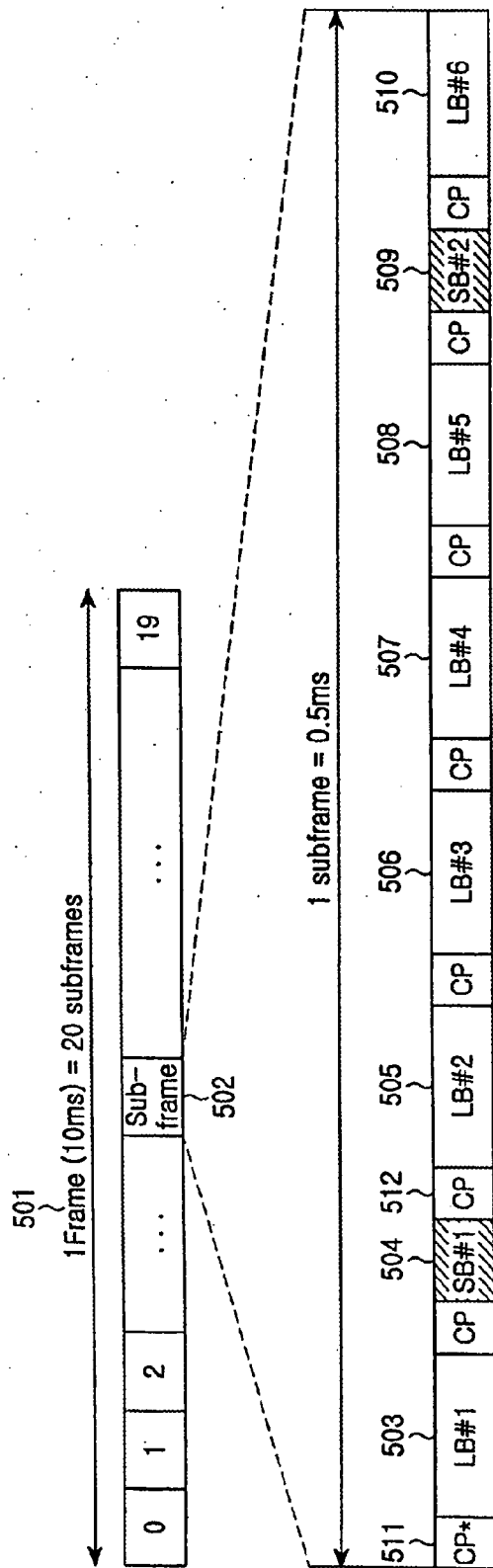

FIG.5



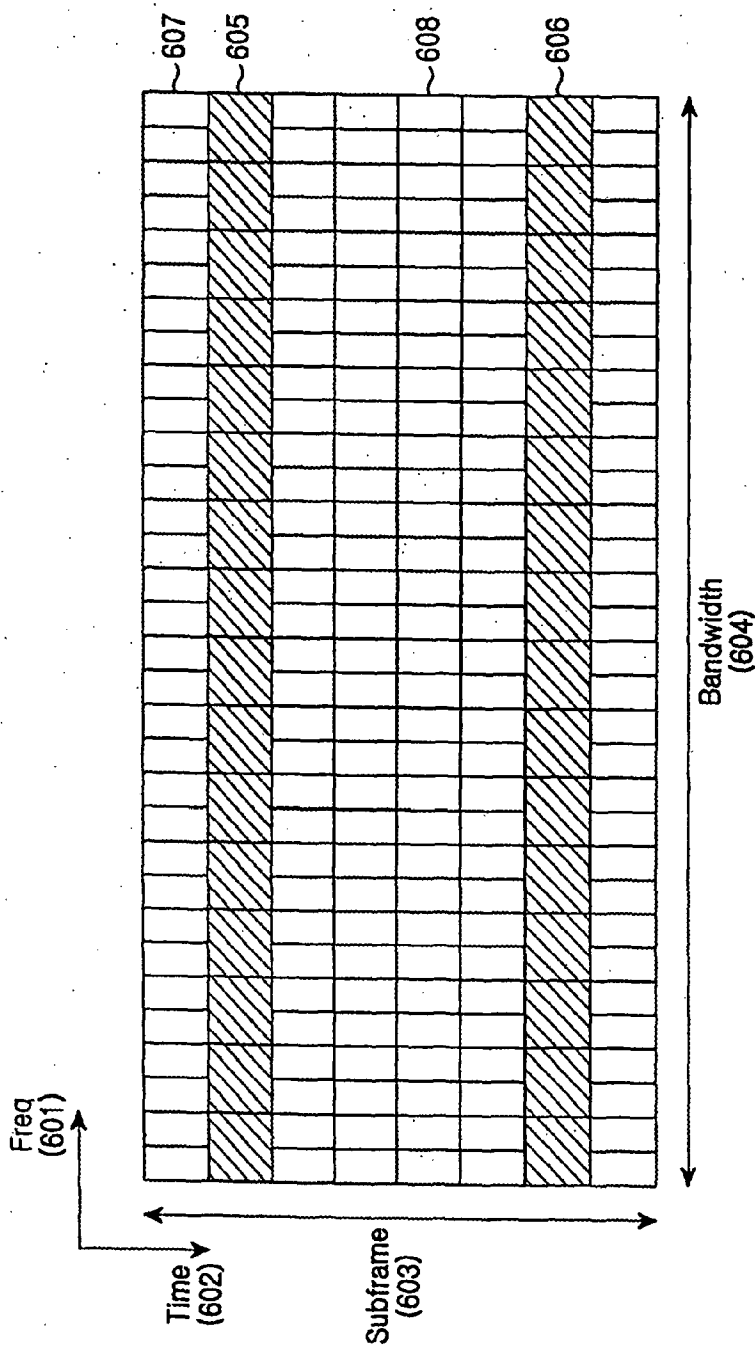

FIG.6

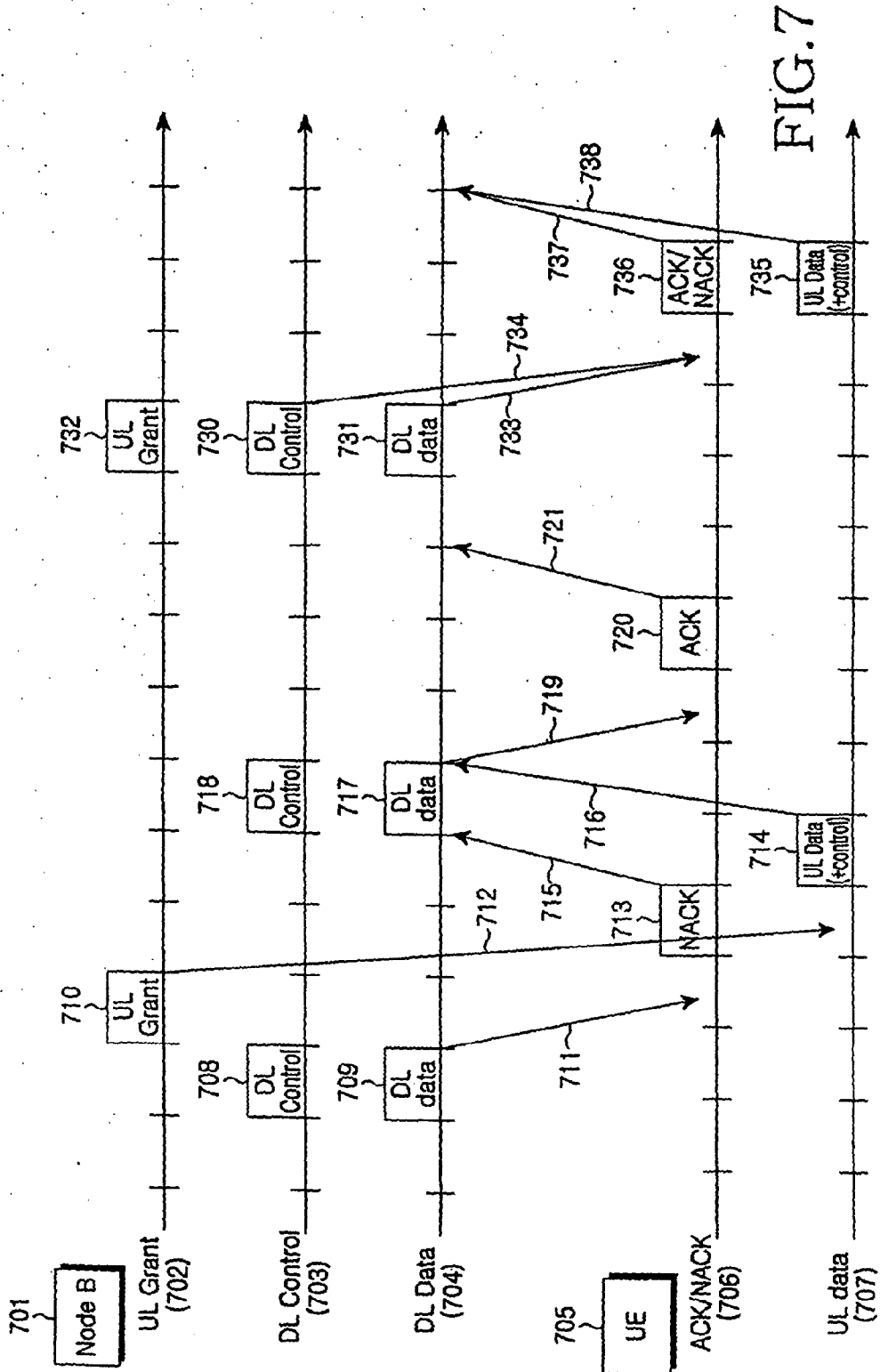

FIG. 7

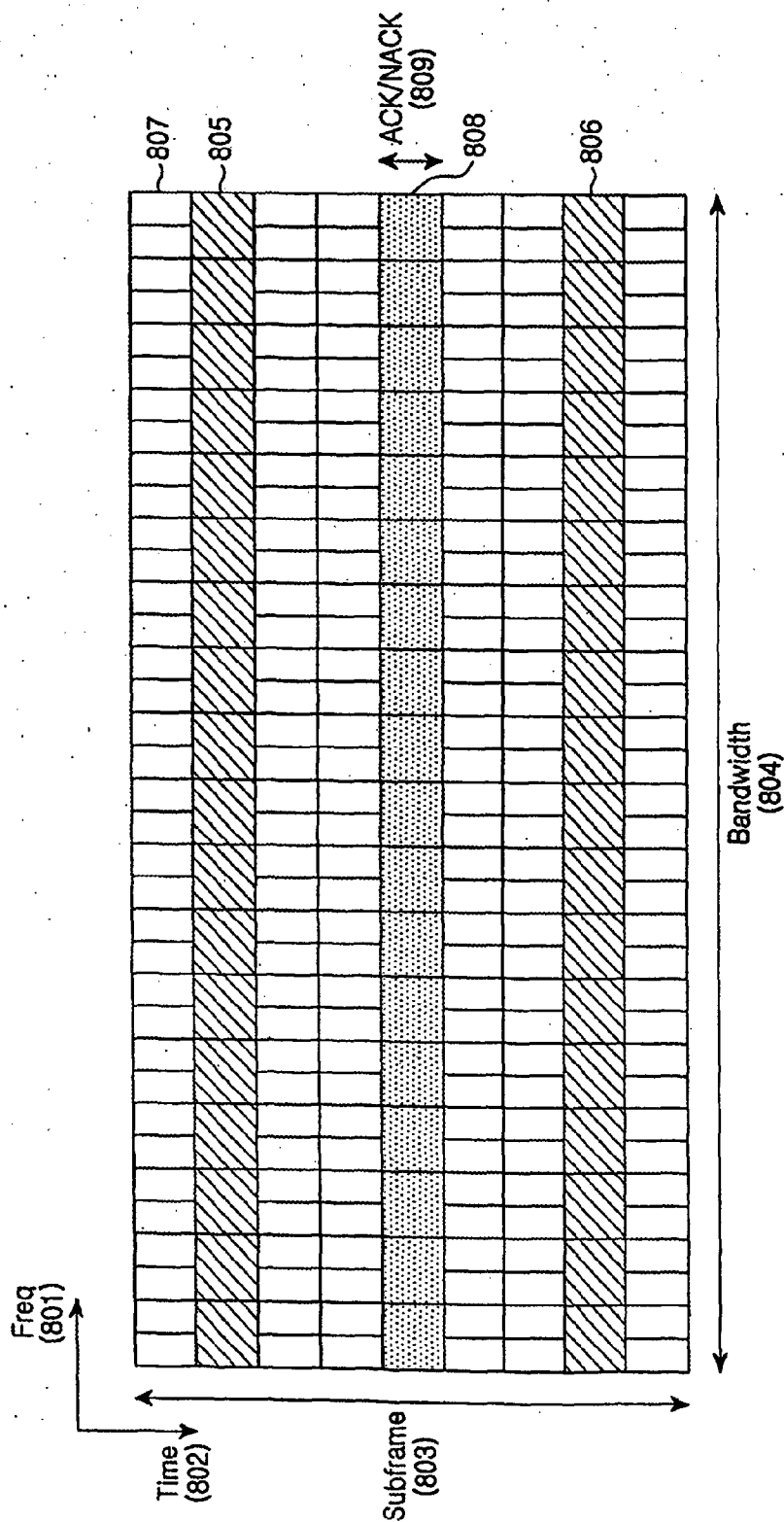

FIG. 8

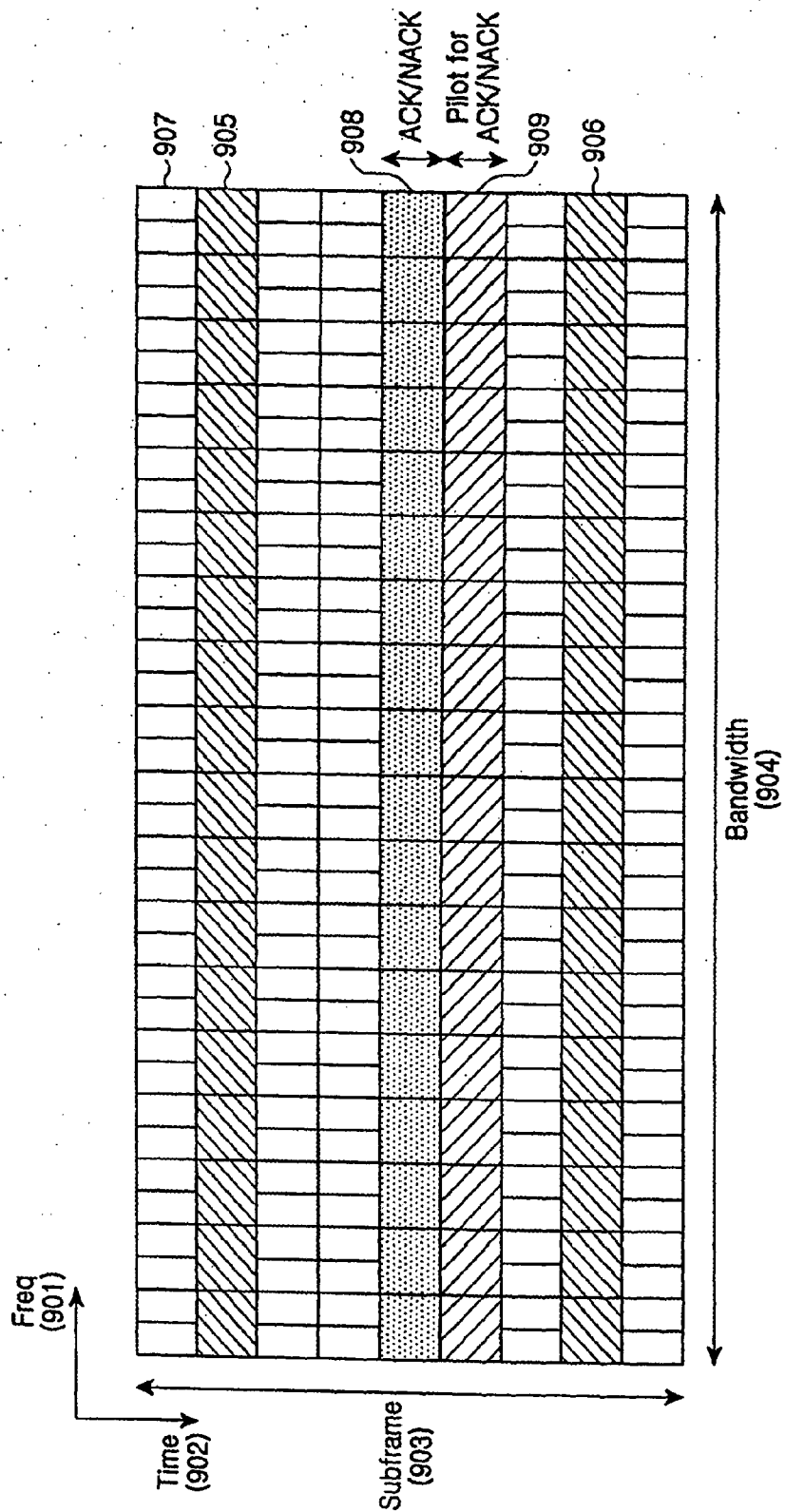

FIG.9

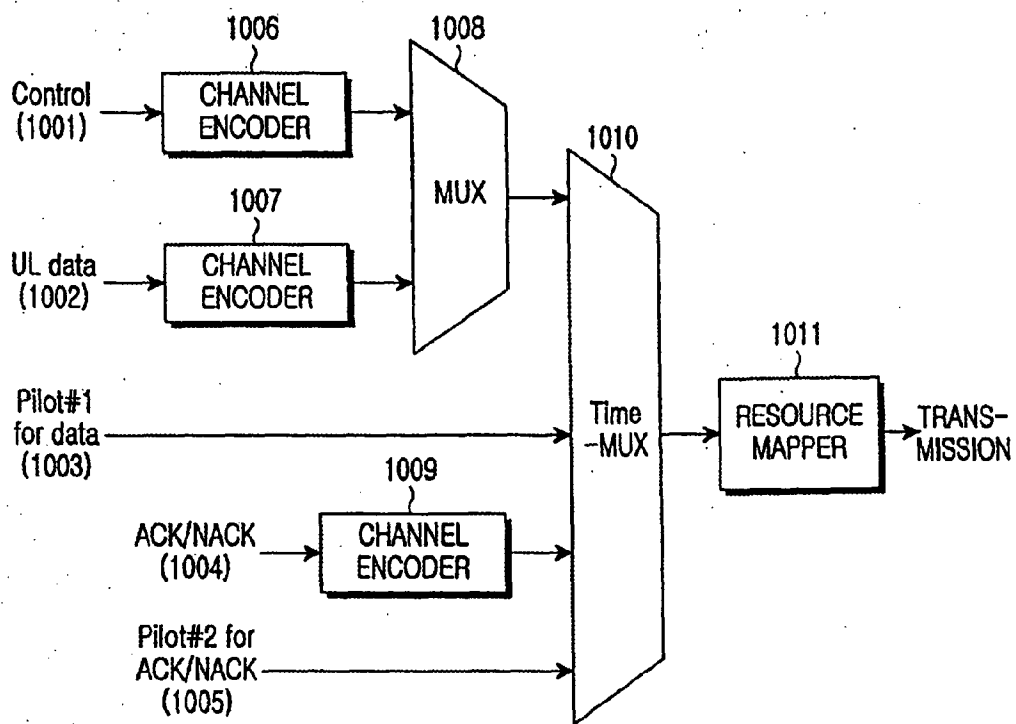

FIG. 10

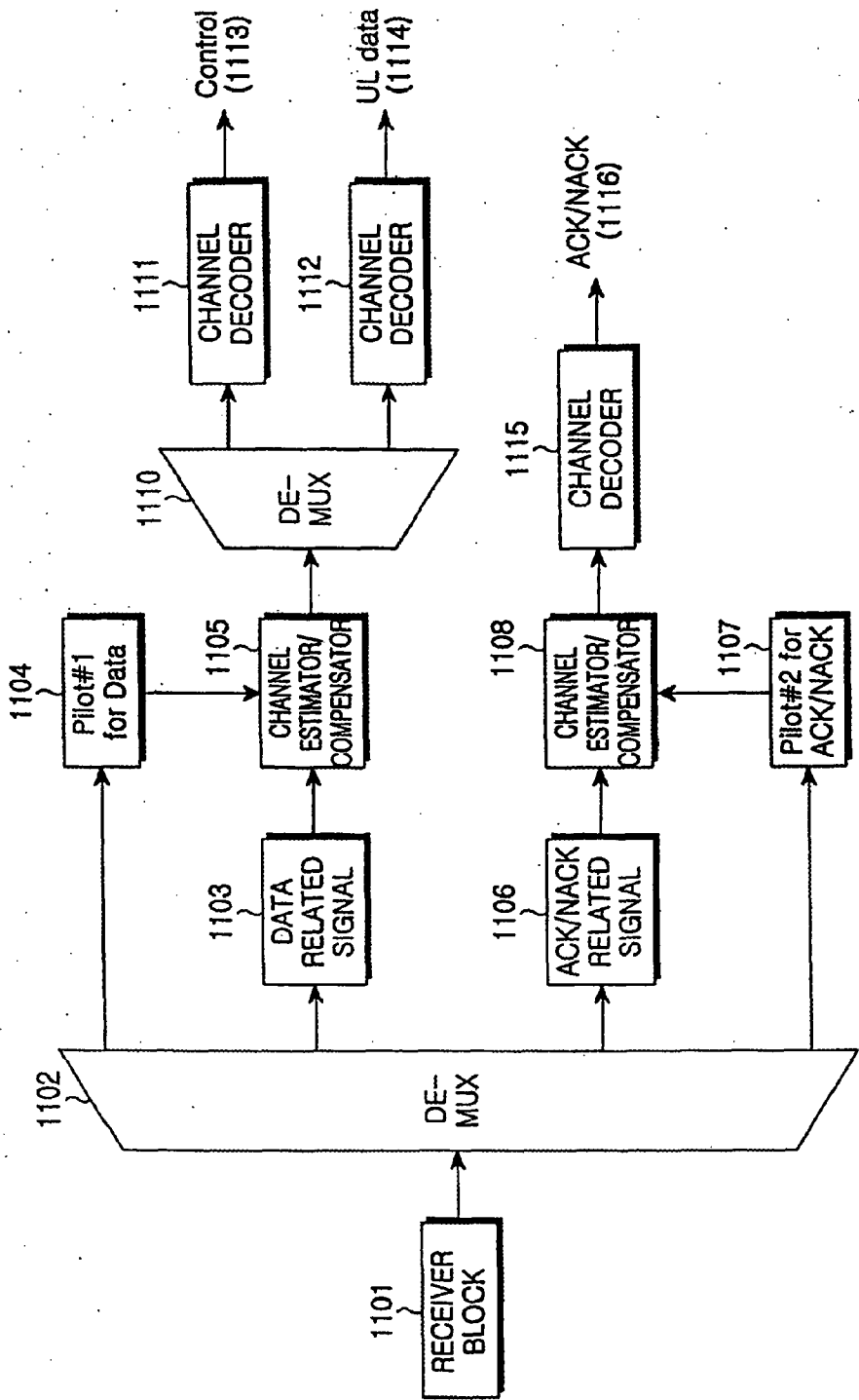

FIG. 11

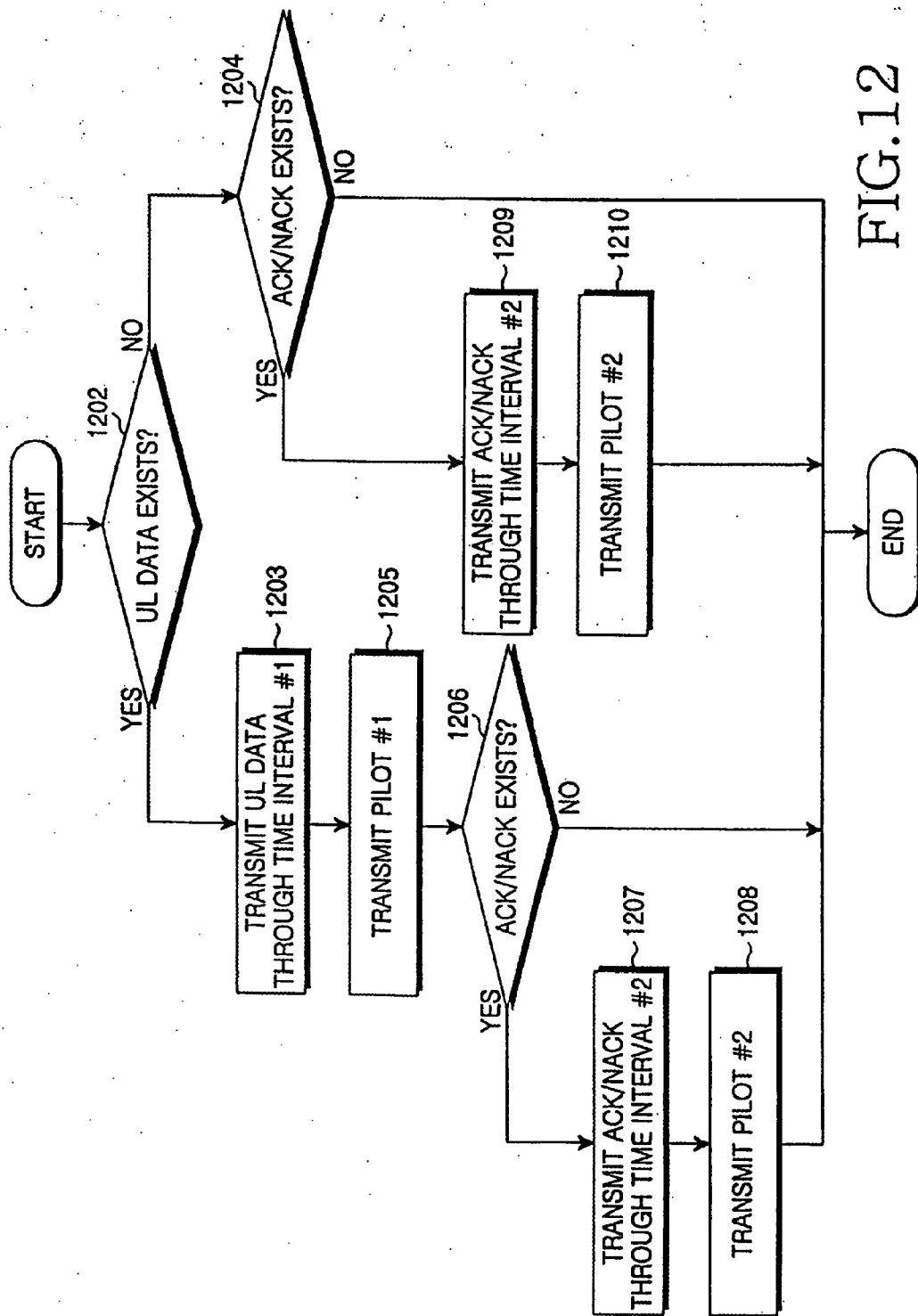

FIG.12

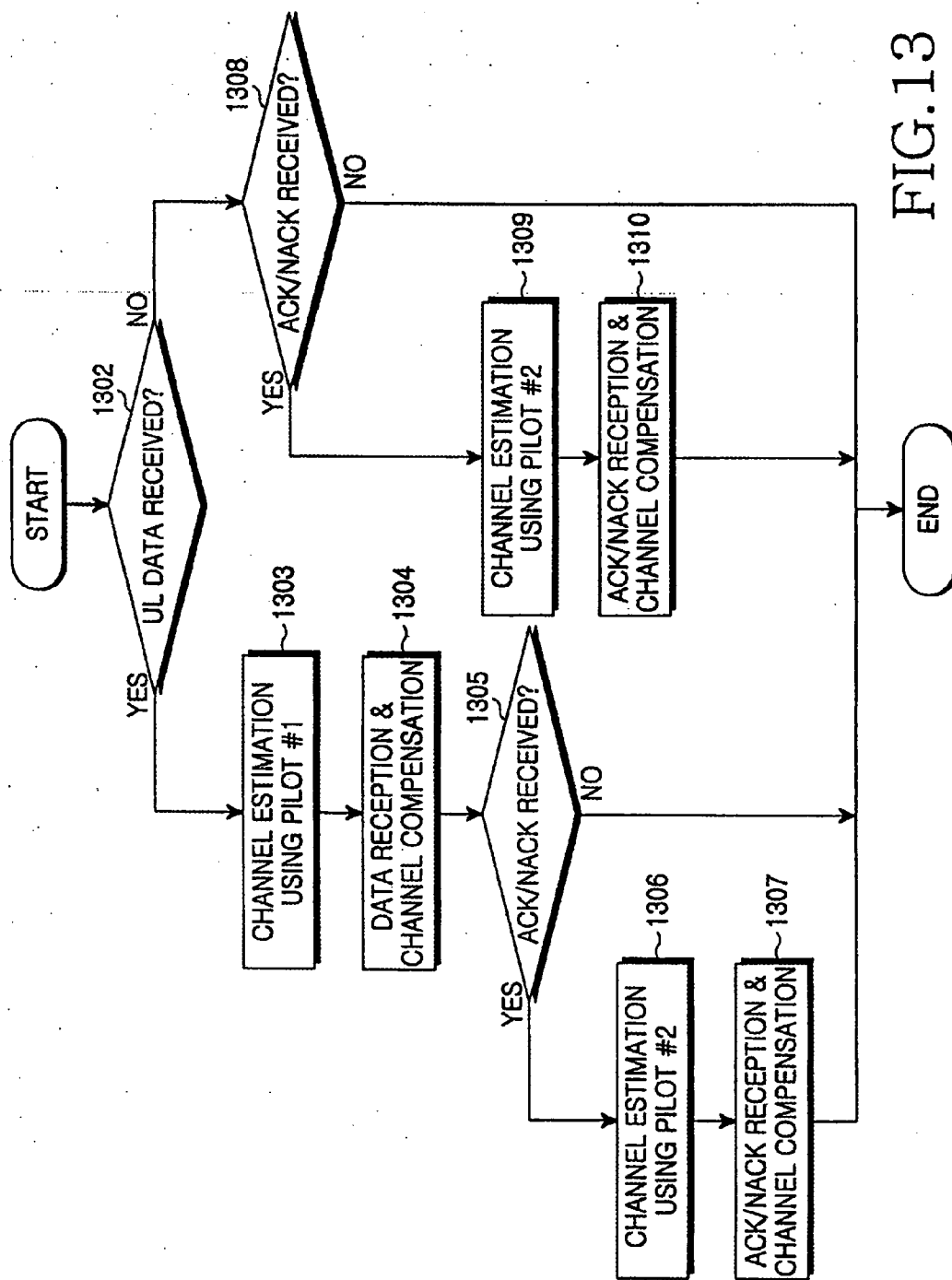

FIG.13



EP 1 806 867 A2

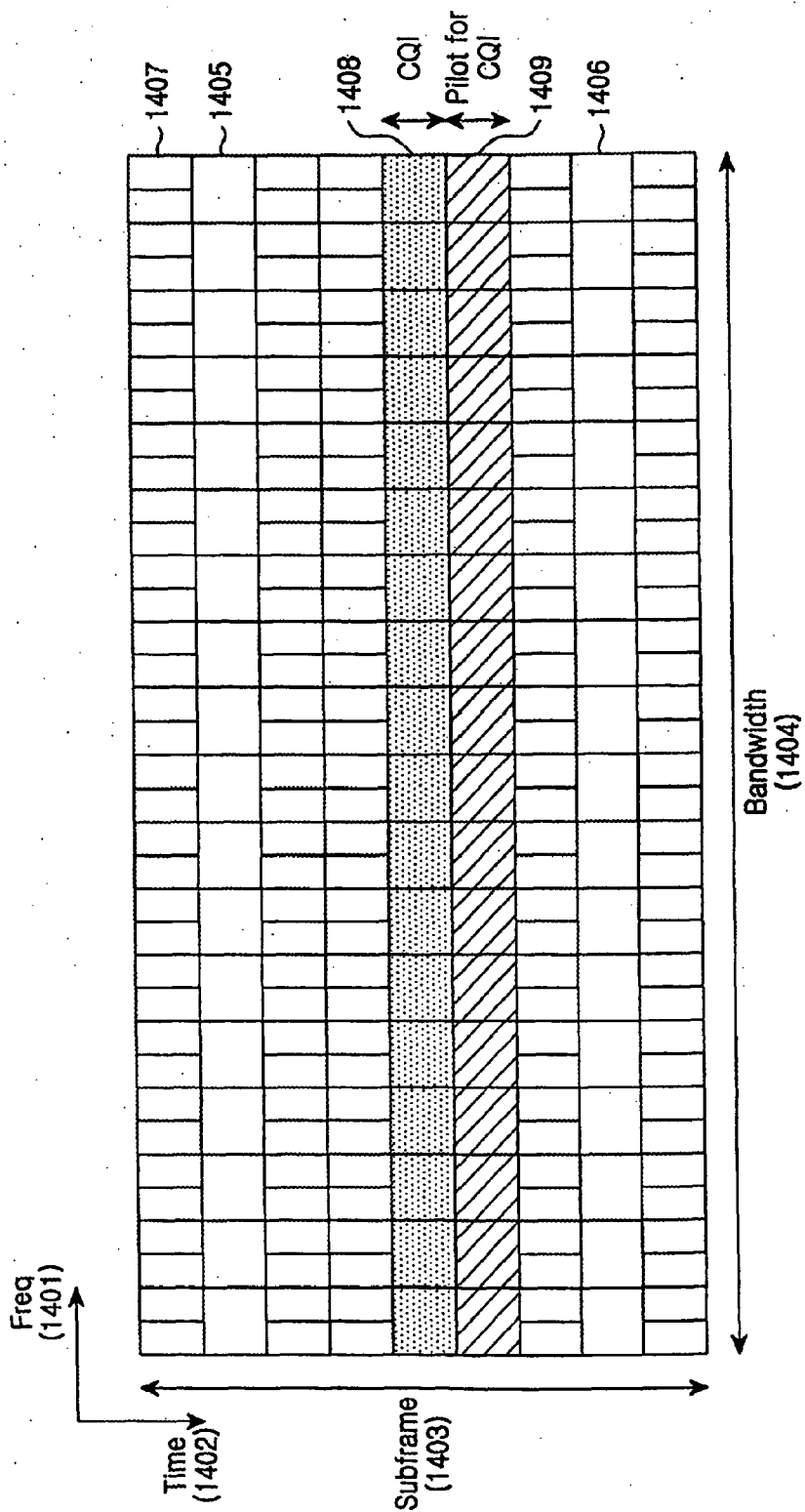

FIG.14

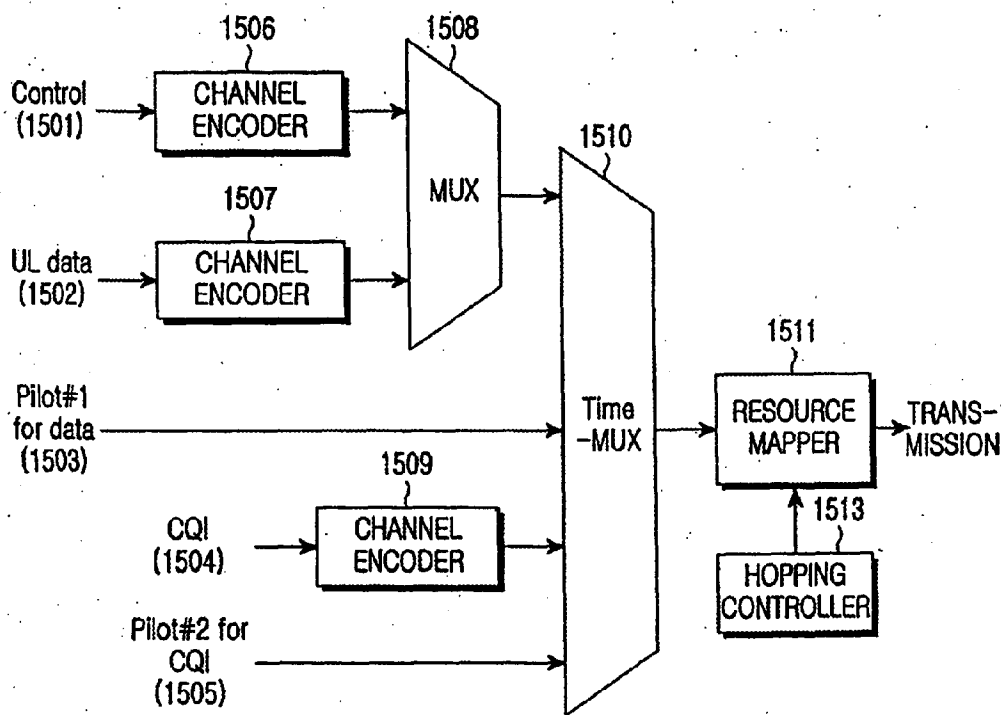

FIG.15

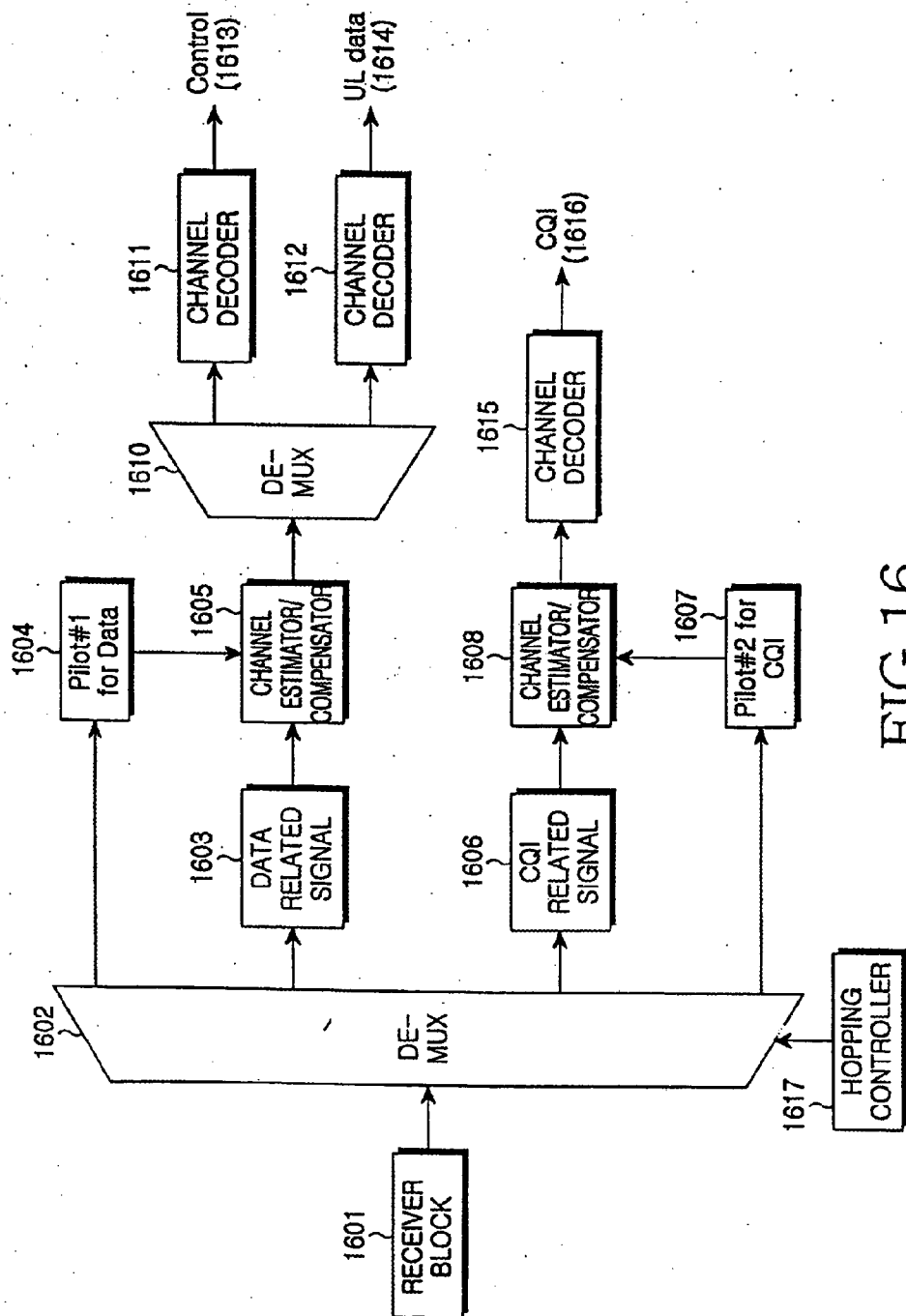

FIG.16

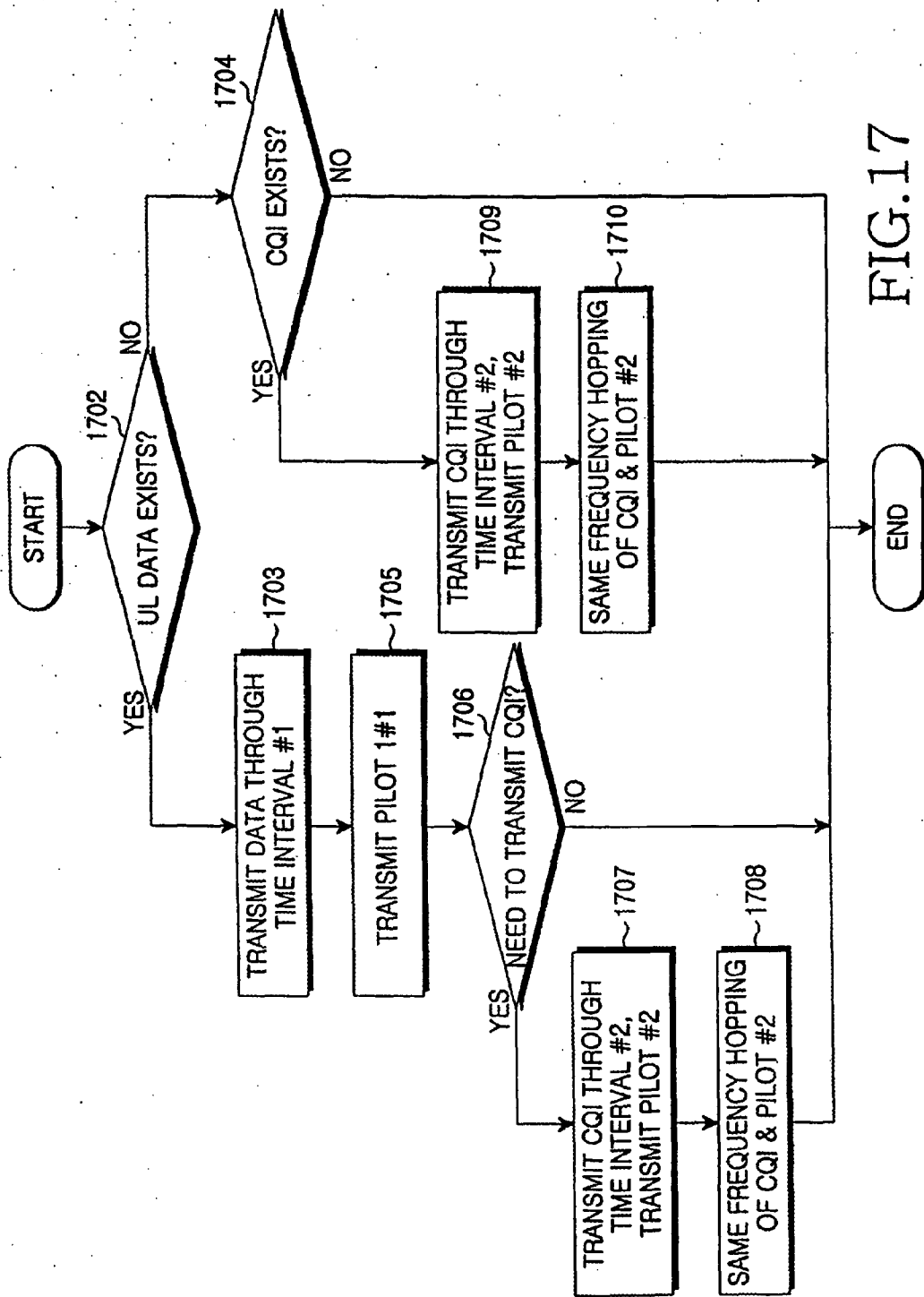

FIG.17

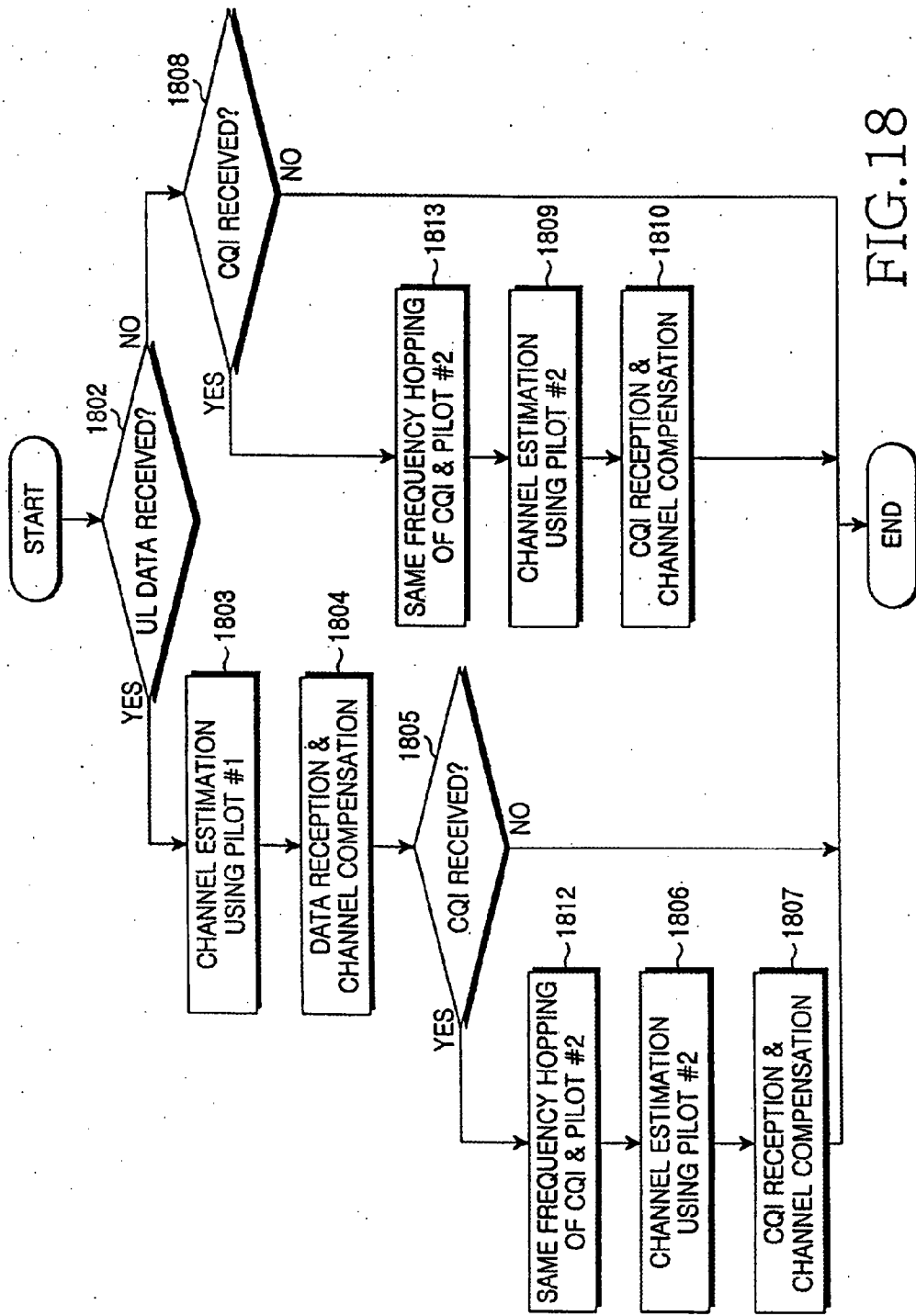
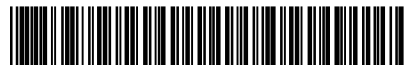

FIG.18



(11) EP 1 811 701 A2

(12) EUROPEAN PATENT APPLICATION

(43) Date of publication: 25.07.2007 Bulletin 2007/30

(51) Int Cl.: H04J 11/00 (2006.01)

(21) Application number: 07100112.7

(22) Date of filing: 04.01.2007

(84) Designated Contracting States:  
**AT BE BG CH CY CZ DE DK EE ES FI FR GB GR HU IE IS IT LI LT LU LV MC NL PL PT RO SE SI SK TR**  
 Designated Extension States:  
**AL BA HR MK YU**

(72) Inventors:  
 • Kwak, Yong-Jun  
 Gyeonggi-do (KR)  
 • Lee, Ju-Ho  
 Gyeonggi-do (KR)  
 • Cho, Joon-Young  
 Gyeonggi-do (KR)

(30) Priority: 06.01.2006 KR 20060001849  
 26.06.2006 KR 20060057693

(74) Representative: Zimmer, Franz-Josef  
 Grünecker, Kinkeldey,  
 Stockmair & Schwanhäusser  
 Anwaltssozietät  
 Maximilianstrasse 58  
 80538 München (DE)

(71) Applicant: Samsung Electronics Co., Ltd.  
 Suwon-si, Gyeonggi-Do (KR)

(54) Method and apparatus for transmitting/receiving uplink signaling information in a single carrier FDMA system

(57) A method and an apparatus for transmitting uplink information items having various characteristics by using a single Fast Fourier Transform (FFT) block. The method includes determining whether uplink signaling information exists to be transmitted when uplink data exists to be transmitted; multiplexing the uplink data and control information for the uplink data and transmitting multiplexed data through a first frequency resource allocated for the uplink data, when no uplink signaling information

exists; multiplexing the uplink data, control information for the uplink data, and the uplink signaling information, and transmitting multiplexed data through a first frequency resource allocated for the uplink data, when the uplink signaling information exists; and transmitting the uplink signaling information through a second frequency resource allocated for the uplink signaling information, when no uplink data is to be transmitted and the uplink signaling information exists to be transmitted.

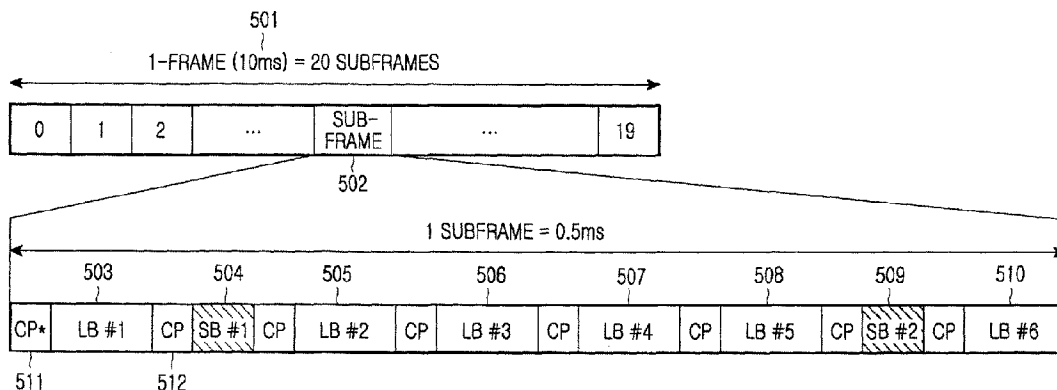

FIG.5

EP 1 811 701 A2

**Description****BACKGROUND OF THE INVENTION**1. Field of the Invention

**[0001]** The present invention relates to a method and an apparatus for transmitting/receiving uplink signaling information and uplink data in a Frequency Division Multiple Access (FDMA) wireless communication system using a single carrier.

2. Description of the Related Art

**[0002]** An Orthogonal Frequency Division Multiplexing (OFDM) scheme or a Single Carrier-Frequency Division Multiple Access (SC-FDMA) scheme similar to the OFDM scheme have been actively researched as a scheme available for high speed data transmission through a wireless channel in a mobile communication system.

**[0003]** An OFDM scheme, which transmits data using multiple carriers, is a special type of a Multiple Carrier Modulation (MCM) scheme in which a serial symbol sequence is converted into parallel symbol sequences, and the parallel symbol sequences are modulated with a plurality of mutually orthogonal subcarriers (or subcarrier channels) before being transmitted.

**[0004]** FIG. 1 shows a transmitter of a typical OFDM system. The OFDM transmitter includes a channel encoder 101, a modulator 102, a serial-to-parallel (S/P) converter 103, an Inverse Fast Fourier Transform (IFFT) block or a Digital Fourier Transform (DFT) block 104, a parallel-to-serial (P/S) converter 105, and a Cyclic Prefix (CP) inserter 106.

**[0005]** The channel encoder 101 receives and channel-encodes a information bit sequence. In general, a convolutional encoder, a turbo encoder, or a Low Density Parity Check (LDPC) encoder are used as the channel encoder 101. The modulator 102 modulates the channel-encoded bit sequence according to a modulation scheme, such as a Quadrature Phase Shift Keying (QPSK) scheme, a 8PSK scheme, a 16-ary Quadrature Amplitude Modulation (16QAM) scheme, a 64QAM scheme, a 256QAM scheme, etc. Meanwhile, although not shown in FIG. 1, it is obvious that a rate matching block for performing repetition and puncturing may be inserted between the channel encoder 101 and the modulator 102.

**[0006]** The S/P converter 103 receives output data from the modulator 102 and converts the received data into parallel data. The IFFT block 104 receives the parallel data output from the S/P converter 103 and performs an IFFT operation on the parallel data. The data output from the IFFT block 104 is converted to serial data by the P/S converter 105. The CP inserter 106 inserts a CP into the serial data output from the P/S converter 105, thereby generating an OFDM symbol to be transmitted.

**[0007]** The IFFT block 104 converts the input data of

the frequency domain to output data of the time domain. In a typical OFDM system, because input data is processed in the frequency domain, a Peak to Average Power Ratio (PAPR) of the data may increase when the data have been converted into the time domain.

**[0008]** A PAPR is one of the most important factors to be considered in the uplink transmission. As PAPR increases, the cell coverage decreases, so signal power required by a terminal increases. Therefore, it is necessary to first reduce the PAPR, and it is thus possible to use an SC-FDMA scheme, which is a scheme modified from the typical OFDM scheme, for the OFDM-based uplink transmission. That is to say, it is possible to effectively reduce the PAPR by enabling processing in the time domain without performing processing (channel encoding, modulation, etc.) of data in the frequency domain.

**[0009]** FIG. 2 shows a transmitter in a system employing an SC-FDMA scheme, which is a typical uplink transmission scheme. The SC-FDMA transmitter includes a channel encoder 201, a modulator 202, a serial-to-parallel (S/P) converter 203, a Fast Fourier Transform (FFT) block 204, a sub-carrier mapper 205, an IFFT block 206, a parallel-to-serial (P/S) converter 207, and a CP inserter 208.

**[0010]** The channel encoder 201 receives and channel-encodes a information bit sequence. The modulator 202 modulates the output of the channel encoder 201 according to a modulation scheme, such as a QPSK scheme, an 8PSK scheme, a 16QAM scheme, a 64QAM scheme, a 256QAM scheme, etc. A rate matching block may be omitted between the channel encoder 201 and the modulator 202.

**[0011]** The S/P converter 203 receives data output from the modulator 202 and converts the received data into parallel data. The FFT block 204 performs an FFT operation on the data output from the S/P converter 203, thereby converting the data into data of the frequency domain. The sub-carrier mapper 205 maps the output data of the FFT block 204 to the input of the IFFT block 206. The IFFT block 206 performs an IFFT operation on the data output from the sub-carrier mapper 205. The output data of the IFFT block 206 is converted to parallel data by the P/S converter 207. The CP inserter 208 inserts a CP into the parallel data output from the P/S converter 207, thereby generating an OFDM symbol to be transmitted.

**[0012]** FIG. 3 shows in more detail the structure for resource mapping shown in FIG 2. Hereinafter, the operation of the sub-carrier mapper 205 will be described with reference to FIG. 3. Data symbols 301 having been subjected to the channel encoding and modulation are input to an FFT block 302. The output of the FFT block 302 is input to an IFFT block 304. A sub-carrier mapper 303 maps the output data of the FFT block 302 to the input data of the IFFT block 304.

**[0013]** The sub-carrier mapper 303 maps the information symbols of the frequency domain data converted by the FFT block 302 to corresponding input points or input

taps of the IFFT block 304 so the information symbols can be carried by proper sub-carriers.

**[0014]** During the mapping procedure, when the output symbols of the FFT block 302 are sequentially mapped to neighboring input points of the IFFT block 304, the output symbols are transmitted by sub-carriers that are consecutive in the frequency domain. This mapping scheme is called a Localized Frequency Division Multiple Access (LFDMA) scheme.

**[0015]** Further, when the output symbols of the FFT block 302 are mapped to input points of the IFFT block 304 having a predetermined interval between them, the output symbols are transmitted by sub-carriers having equal intervals between them in the frequency domain. This mapping scheme is called either an Interleaved Frequency Division Multiple Access (IFDMA) scheme or a Distributed Frequency Division Multiple Access (DFDMA) scheme.

**[0016]** Although FIGs. 2 and 3 show one method of implementing the SC-FDMA technology in the frequency domain, it is also possible to use various other methods, such as a method of implementing the technology in the time domain.

**[0017]** Diagrams (a) and (b) in FIG. 4 are views for comparison between the positions of sub-carriers used for the DFDMA and the LFDMA in the frequency domain. In diagram (a), the transmission symbols of a terminal using the DFDMA scheme are distributed with equal intervals over the entire frequency domain (that is, the system band). In diagram (b), the transmission symbols of a terminal using the LFDMA scheme are consecutively located at some part of the frequency domain.

**[0018]** According to the LFDMA scheme, because consecutive parts of the entire frequency band are used, it is possible to obtain a frequency scheduling gain by selecting a partial frequency band having good channel gain in the frequency selective channel environment in which severe channel change of frequency bands occurs. In contrast, according to the DFDMA scheme, it is possible to obtain a frequency diversity gain as transmission symbols have various channel gains by using a large number of sub-carriers distributed over a wide frequency band.

**[0019]** In order to maintain a characteristic of a single carrier as described above, simultaneously transmitted information symbols should be mapped to the IFFT block so they can always satisfy the LFDMA or DFDMA after passing through a single FFT block (or DFT block).

**[0020]** In an actual communication system, various information symbols may be transmitted. For example, in the uplink of a Long Term Evolution (LTE) system using the SC-FDMA based on a Universal Mobile Telecommunications System (UMTS), uplink data, control information regulating a transport scheme of the uplink data (which includes Transport Format (TF) information of the uplink data and/or Hybrid Automatic Repeat reQuest (HARQ) information), an ACKnowledgement/Negative ACKnowledgment (ACK/NACK) for a HARQ operation

for downlink data, a Channel Quality Indication (CQI) indicating the channel status reported to be used for scheduling of a base station, etc. may be transmitted. Those enumerated information items have different transmission characteristics, respectively.

**[0021]** Uplink data can be transmitted in a situation in which a terminal has data in a transmission buffer of the terminal and has received permission for uplink transmission from a base station. The control information regulating the transport scheme of the uplink data is transmitted only when the uplink data is transmitted. Sometimes, uplink data may be transmitted without transmission of control information. In contrast, the ACK/NACK, which is transmitted in response to downlink data, has no relation to transmission of uplink data. That is, either both the uplink data and the ACK/NACK may be simultaneously transmitted or only one of them may be transmitted. Further, the CQI, which is transmitted at a given time, also has no relation to transmission of uplink data. That is, either both the uplink data and the CQI may be simultaneously transmitted or only one of them may be transmitted.

**[0022]** As described above, various types of uplink information are transmitted in the SC-FDMA system. Under the restriction of use of a single FFT block, which is a characteristic of a single sub-carrier, it is necessary to effectively control transmission of information in order to transmit various types of information as described above. That is to say, it is necessary to arrange a specific transmission rule when only uplink data is transmitted, when only an ACK/NACK or a CQI is transmitted, and when both uplink data and uplink signaling information (ACK/NACK or CQI) are transmitted.

### SUMMARY OF THE INVENTION

**[0023]** Accordingly, the present invention has been made to solve the above-mentioned problems occurring in the prior art, and provides a method and an apparatus for transmitting uplink information items having various characteristics by using a single FFT block.

**[0024]** The present invention also provides a method and an apparatus for transmitting uplink signaling information, such as ACK/NACK or CQI, according to existence or absence of uplink data.

**[0025]** The present invention also provides a method and an apparatus for indicating whether the uplink signaling information, such as ACK/NACK or CQI, uses resources allocated to uplink data in transmission of the uplink data.

**[0026]** In order to accomplish this object, there is provided a method for transmitting multiple types of uplink information in an SC-FDMA wireless communication system, the method including determining whether uplink signaling information exists to be transmitted when uplink data exists to be transmitted; multiplexing the uplink data and control information for the uplink data and transmitting multiplexed data through a first frequency resource



allocated for the uplink data, when no uplink signaling information exists; multiplexing the uplink data, control information for the uplink data, and the uplink signaling information, and transmitting multiplexed data through a first frequency resource allocated for the uplink data, when the uplink signaling information exists; and transmitting the uplink signaling information through a second frequency resource allocated for the uplink signaling information, when no uplink data is to be transmitted and the uplink signaling information exists to be transmitted.

**[0027]** In accordance with another aspect of the present invention, there is provided an apparatus for transmitting multiple types of uplink information in an SC-FDMA wireless communication system, the apparatus including a multiplexer for multiplexing uplink data and control information for the uplink data when the uplink data exists to be transmitted and no uplink signaling information is to be transmitted, and multiplexing uplink data, control information for the uplink data, and the uplink signaling information when both the uplink data exists to be transmitted and the uplink signaling information exists to be transmitted; a data resource mapper for transmitting information multiplexed by the multiplexer through a first frequency resource allocated for the uplink data; and an uplink signaling resource mapper for transmitting the uplink signaling information through a second frequency resource allocated for the uplink signaling information, when no uplink data is to be transmitted.

**[0028]** In accordance with another aspect of the present invention, there is provided a method for receiving multiple types of uplink information in an SC-FDMA wireless communication system, the method including determining whether uplink data has been received through a first frequency resource allocated for the uplink data; determining whether information received through the first frequency resource includes uplink signaling information, when the uplink data has been received; demultiplexing the information received through the first frequency resource into the uplink data and control information for the uplink data, when the information received through the first frequency resource does not include uplink signaling information; demultiplexing the information received through the first frequency resource into the uplink data, control information for the uplink data, and uplink signaling information, when the information received through the first frequency resource includes the uplink signaling information; and receiving the uplink signaling information through a second frequency resource allocated for the uplink signaling information, when the uplink data has not been received.

**[0029]** In accordance with another aspect of the present invention, there is provided an apparatus for receiving multiple types of uplink information in an SC-FDMA wireless communication system, the apparatus including a determination unit for determining whether information includes uplink signaling information, when the information has been received through a first frequency resource allocated for uplink data; a demultiplexer for

demultiplexing the information received through the first frequency resource into the uplink data and control information for the uplink data when the information received through the first frequency resource does not include uplink signaling information, and demultiplexing the information received through the first frequency resource into the uplink data, control information for the uplink data, and uplink signaling information, when the information received through the first frequency resource includes the uplink signaling information; and a receiver unit for receiving the uplink signaling information through a second frequency resource allocated for the uplink signaling information, when no information is received through the first frequency resource.

## BRIEF DESCRIPTION OF THE DRAWINGS

**[0030]** The above and other objects, features and advantages of the present invention will be more apparent from the following detailed description taken in conjunction with the accompanying drawings, in which:

FIG. 1 is a block diagram illustrating a structure of a transmitter of a typical OFDM system;

FIG. 2 is a block diagram illustrating a structure of a transmitter in a system employing an SC-FDMA scheme, which is a typical uplink transmission scheme;

FIG. 3 is a block diagram illustrating in more detail the structure for resource mapping shown in FIG. 2; FIG. 4 are views for comparison between the positions of sub-carriers used for the DFDMA and the LFDMA in the frequency domain;

FIG. 5 illustrates structures of an uplink transmission frame and its sub-frame of an LTE system according to the present invention;

FIG. 6 illustrates the sub-frame 502 of FIG. 5 on the time domain and the frequency domain according to the present invention;

FIG. 7 illustrates the resources allocated to uplink data and ACK/NACK according to the present invention;

FIG. 8 illustrates use of frequency-time resources according to the first embodiment of the present invention;

FIG. 9 is a flow diagram of an operation of a transmitter according to the first embodiment of the present invention;

FIG. 10 is a block diagram illustrating the structure of the transmitter according to the first embodiment of the present invention;

FIG. 11 is a flow diagram of an operation of a receiver according to the first embodiment of the present invention;

FIG. 12 is a block diagram illustrating the structure of the receiver according to the first embodiment of the present invention;

FIG. 13 is a flow diagram of an operation of a trans-

mitter according to the second embodiment of the present invention;

FIG. 14 is a block diagram illustrating the structure of the transmitter according to the second embodiment of the present invention;

FIG. 15 is a flow diagram of an operation of a receiver according to the second embodiment of the present invention;

FIG. 16 is a block diagram illustrating the structure of the receiver according to the second embodiment of the present invention;

FIG. 17 illustrates a sub-frame according to the third embodiment of the present invention in which the ACK/NACK and the CQI are multiplexed at the same time;

FIG. 18 illustrates use of frequency-time resources according to the third embodiment of the present invention;

FIG. 19 illustrates a structure of CQI information according to the third embodiment of the present invention;

FIG. 20 is a flow diagram of an operation of a transmitter according to the third embodiment of the present invention; and

FIG. 21 is a flow diagram of an operation of a receiver according to the third embodiment of the present invention.

#### DETAILED DESCRIPTION OF THE PREFERRED EMBODIMENTS

[0031] Hereinafter, preferred embodiments of the present invention will be described with reference to the accompanying drawings. In the following description, a detailed description of known functions and configurations incorporated herein will be omitted when it may make the subject matter of the present invention rather unclear. Further, in the following description of the present invention, various specific definitions are provided only to help general understanding of the present invention, and it is apparent to those skilled in the art that the present invention can be implemented without such definitions.

[0032] The present invention multiplexes different types of uplink information to enable transmission of the uplink information, which can satisfy a single carrier (SC) characteristic in a wireless communication system using a Single Carrier Frequency Division Multiple Access (SC-FDMA) scheme. The following description discusses multiplexing for uplink transmission of uplink data, control information, Acknowledgement/Negative ACKnowledgement (ACK/NACK), Channel Quality Indication (CQI), etc. in an SC-FDMA wireless communication system. As used herein, the other information except for the uplink data and control information thereof, that is, information including ACK/NACK and CQI, is referred to as "uplink signaling information."

[0033] A Long Term Evolution (LTE) system, which is

being standardized by the 3<sup>rd</sup> Generation Partnership Project (3GPP), is discussed in order to describe the present invention. The LTE system employs a SC-FDMA scheme for uplink transmission. FIG 5 shows an uplink transmission frame and its sub-frame according to the present invention.

[0034] In FIG. 5, reference numeral 501 denotes a radio frame, which is an uplink transmission unit and is defined to have a length of 10 ms. One radio frame 501 includes 20 sub-frames 502, each of which has a length of 0.5 ms. Further, each sub-frame 502 includes six Long Blocks (LBs) 503, 505, 506, 507, 508, and 510, two Short Blocks (SBs) 504 and 509, and CPs 511 and 512 located before the blocks one before one. The LBs 503 to 510 carry information except for pilots used as a reference for coherent modulation, and SBs 504 and 509 are used to carry the pilots.

[0035] FIG. 6 shows the sub-frame 502 of FIG. 5 on the time domain and the frequency domain according to the present invention. The horizontal axis indicates the frequency domain 601 and the vertical axis indicates the time domain 602. The range of the frequency domain 601 corresponds to the entire frequency band 604 and the range of the time domain 602 corresponds to one sub-frame 603. As noted, the SBs 605 and 607 carry pilots, and the LBs 607 and 608 carry other information except for the pilots.

[0036] As described above, uplink data transmitted according to resource allocation by a base station, control information in relation to the uplink data, ACK/NACK for indicating success or failure in reception of downlink data, CQI for indicating a channel status, etc. are transmitted by using the uplink resource.

[0037] A determination to transmit the uplink data is made according to scheduling of a base station, and a determination of a resource to be used is also made according to allocation by the base station. The control information transmitted together with the uplink data is also transmitted according to the resources allocated by the base station. In contrast, since the ACK/NACK is generated based on downlink data, the ACK/NACK is transmitted using an uplink resource automatically allocated according to whether the downlink data is transmitted, in response to the control channel defining the downlink data or the downlink data channel. Further, since it is usual that the CQI is periodically transmitted, the CQI is transmitted using a resource determined in advance through setup by higher signaling.

[0038] Because the information items use a variety of resource allocation methods as described above, the variety of resource allocation methods are simultaneously used when various types of information are transmitted together. In order to satisfy a characteristic of a single sub-carrier, the resource used during one sub-frame must necessarily maintains a characteristic of the LFDMA or DFDMA. For example, when uplink data and ACK/NACK are transmitted simultaneously, that is, during one Transmission Time Interval (TTI), the uplink data uses

the resource allocated by the base station, and the ACK/NACK uses a resource determined by another method, for example, a resource determined according to a control channel for downlink data. Therefore, use of the two resources may cause a contradiction to a characteristic of a single sub-carrier, thereby increasing the PAPR. Therefore, the present invention provides a method by which simultaneously transmitted information items can always maintain a characteristic of a single sub-carrier.

**[0039]** Specifically, transmission of uplink data and ACK/NACK together will be described hereinafter. The transmission of uplink data may be accompanied with transmission of control information of the uplink data. Further, the discussion below may also be applied to other uplink signaling information, such as the CQI instead of the ACK/NACK.

**[0040]** In order to always maintain a characteristic of a single sub-carrier either when only one of the ACK/NACK and the uplink data is transmitted or when both of them are simultaneously transmitted, the present invention provides the following method. That is, when only one of the ACK/NACK and the uplink data is transmitted, a resource allocated to the corresponding information is used. Specifically, when only the uplink data is transmitted, the uplink data is transmitted by using the resource allocated by the base station. When only the ACK/NACK is transmitted, the ACK/NACK is transmitted by using the resource determined for the transmission of the ACK/NACK. However, when both of the ACK/NACK and the uplink data are simultaneously transmitted, the ACK/NACK and the uplink data are transmitted by using only the resource allocated for the uplink data, and the resource determined for the transmission of the ACK/NACK is disregarded. In other words, the ACK/NACK and the uplink data are simultaneously transmitted by using the resource allocated for the uplink data.

**[0041]** FIG. 7 shows resources allocated to uplink data and ACK/NACK according to the present invention. Reference numeral 701 denotes a frequency domain and reference numeral 702 denotes a time domain. Further, within one time interval, sub-carriers allocated to data corresponds to a first resource 703 and sub-carriers allocated to the ACK/NACK corresponds to a second resource 704. The resources 703 and 704 allocated to the uplink data and the ACK/NACK as described above are separated on the frequency domain. Although FIG. 7 shows logical separation between the resources 703 and 704 allocated to the uplink data and the ACK/NACK, the resources 703 and 704 are separated into two sub-carrier sets not only when the LFDMA is used but also when the FDMA is used.

**[0042]** When the entire frequency resources have been divided into two sub-carrier sets, uplink data is transmitted by using a first resource 703 when there exists only the uplink data, while ACK/NACK is transmitted by using a second resource 704 when only the ACK/NACK exists. In contrast, when both the uplink data and the ACK/NACK exist, both the uplink data and the ACK/

NACK are multiplexed and transmitted by using only the first resource 703 without using the second resource 704.

**[0043]** That is, the transmission position of the ACK/NACK changes according to whether uplink data exists. In transmitting the uplink data, the quantity of information is different and the transport format of the uplink data is thus different according to whether the ACK/NACK exists. Therefore, the type and quantity of information to be transmitted should be promised in advance between the base station and the terminal.

**[0044]** When the terminal transmits only the uplink data and the base station misunderstands that the terminal has transmitted both the uplink data and the ACK/NACK, it is impossible to expect a normal communication because encoding and decoding are performed according to different encoding/decoding schemes. For example, such a communication error may occur when the terminal has successfully received scheduling information for the uplink data but has failed to receive downlink data, and determines that there is no downlink data without sending an ACK/NACK. Therefore, it is necessary for the base station to exactly understand the type and quantity of information transmitted by the terminal. For example, the base station determines the type of the information received from the terminal either by analyzing the information transmitted by the terminal or according to whether the base station has transmitted downlink data to the terminal. For another example, the terminal may clearly report the type of uplink information to the base station.

#### First Embodiment

**[0045]** According to the first embodiment of the present invention, the terminal may inform the base station whether the uplink signaling information (specifically, the ACK/NACK) will be transmitted. Hereinafter, use of frequency-time resources according to the first embodiment of the present invention will be described with reference to FIG. 8.

**[0046]** In FIG. 8, reference numeral 801 denotes one sub-frame used in the uplink of an LTE system, and reference numeral 808 denotes the frequency band allocated for transmission of data. In the frequency band 808, reference numeral 802 denotes a first sub-carrier set allocated to a first terminal that transmits uplink data without ACK/NACK, and reference numeral 803 denotes a second sub-carrier set allocated to a second terminal that transmits uplink data together with ACK/NACK.

**[0047]** In the first sub-carrier set 802, pilots 804 and 806 for channel estimation are transmitted through the allocated time resource. Pilots 804 and 806 have a sequence with a pilot pattern known to the base station and the terminal, representatives of which includes an all 1 sequence (all bits of which have a value of 1). That is, pilots 804 and 806 for sub-carrier set 802 without ACK/NACK are set to have a representative sequence such as an all 1 sequence. In contrast, pilots 805 and 807 for the second sub-carrier set 803 carrying the ACK/NACK

are set to have a sequence different from that of pilots 804 and 806. That is, sub-carrier set 803 uses a pilot other than the all 1 sequence. For example, it uses a pilot having a sequence in which 1 and -1 are alternately repeated. At this time, by setting the minimum distance between the two different sequences to be largest, it is possible to minimize the probability of error in discriminating between the two sequences by the base station.

**[0048]** In brief, the terminal informs the base station through pilots having sequences of different pilot patterns of whether the ACK/NACK is simultaneously transmitted together with uplink data.

**[0049]** FIG. 9 shows an operation of a transmitter (terminal) according to the first embodiment of the present invention, and FIG. 10 shows the transmitter (terminal). Referring to FIG. 9, when the operation of the terminal has started, the terminal determines whether data to be transmitted exists in step 902. When data exists to be transmitted by the terminal, the terminal is instructed through scheduling of the base station, etc. When the determination in step 902 concludes that data exists to be transmitted and the base station has allocated a resource for transmission of the data, the terminal determines whether ACK/NACK exists to be transmitted (step 903). When ACK/NACK exists to be transmitted the information is determined through an HARQ operation for downlink data and based on whether the downlink data has been received.

**[0050]** When it has been determined in step 903 that there is ACK/NACK to be transmitted, the terminal sets pilot pattern #2 having a predetermined sequence as a pilot signal for the data and multiplexes the data, the ACK/NACK, and control information for the data in step 905. Then, in step 908, the terminal maps the multiplexed information to the data resource allocated by the base station, as described above, and then transmits the mapped information. At this time, the pilot signal of pilot pattern #2 is also transmitted through short blocks, which are predetermined time resources of the data resources.

**[0051]** In contrast, when it has been determined in step 903 that no ACK/NACK is to be transmitted, the terminal sets pilot pattern #1 having a predetermined sequence as a pilot signal for the data and multiplexes the data and control information for the data in step 906. Then, in step 909, the terminal maps the multiplexed information to the data resource allocated by the base station as described above and then transmits the mapped information. At this time, the pilot signal of pilot pattern #1 is also transmitted through short blocks, which are predetermined time resources of the data resources. Steps 905 and 906 may be omitted when the terminal does not clearly inform the base station whether the terminal will transmit ACK/NACK.

**[0052]** Meanwhile, when the determination in step 902 concludes that no uplink data is to be transmitted, the terminal determines whether ACK/NACK exists to be transmitted in step 904. When ACK/NACK exists to be transmitted, the terminal transmits the ACK/NACK by us-

ing a resource allocated for the ACK/NACK, that is, by using an ACK/NACK resource corresponding to the resource of the downlink data in step 907. In contrast, when no ACK/NACK is to be transmitted, the process is terminated.

**[0053]** Referring to the transmitter shown in FIG 10, ACK/NACK 1001 for downlink data is subjected to an encoding, such as a repetition coding by a channel encoder 1006, and is then input to a demultiplexer (DEMUX) 1016. The output path from the DEMUX 1016 depends on a signal 104 indicating whether uplink data 1002 exists. Specifically, the DEMUX 1016 is connected to output to path 1009 when uplink data 1002 exists. Otherwise, the DEMUX 1016 is connected to output path 1008.

**[0054]** The uplink data 1002 is encoded by a channel encoder 1013 and is then input to a multiplexer 1015, while the control information 1003 indicating the transport format of the uplink data 1002 is encoded by a channel encoder 1014, and is then input to the multiplexer 1015. Further, the encoded ACK/NACK may be input to the multiplexer 1015 through output path 1009. One of the pilot signals 1011 and 1012 for the resource (data resource) allocated for the uplink data 1002 is input through the switch 1012 to the multiplexer 1015. The selection by the switch 1012 depends on a signal 105 indicating whether ACK/NACK exists. Specifically, the switch 1012 selects the pilot signal 1011 of pilot pattern #1 when the ACK/NACK is not transmitted to the data resource, and selects the pilot signal 1012 of pilot pattern #2 when the ACK/NACK is transmitted to the data resource.

**[0055]** The information multiplexed by the multiplexer 1015 is mapped to the data resource by a data resource mapper 1021 and is then transmitted. The data resource mapper 1021 includes an FFT (or DFT) block, a sub-carrier mapper, and an IFFT block as described above with reference to FIG 2. That is, when both the uplink data 1002 and the ACK/NACK 1001 exist, the uplink data 1002 and the ACK/NACK 1001 are multiplexed before the FFT operation. In contrast, when no uplink data exists, the encoded ACK/NACK output through output path 1008 is mapped to a resource (ACK/NACK resource) appointed for the ACK/NACK by an ACK/NACK resource mapper 1020 and is then transmitted.

**[0056]** FIG 11 shows an operation of a receiver (base station) according to the first embodiment of the present invention, and FIG 12 shows the receiver (base station). Referring to FIG 11, when the operation of the base station has started, the base station determines whether it will receive data from the terminal in step 1102. The determination is made as to whether the base station will receive data from the terminal based on whether the base station has allocated a data resource for uplink to the terminal. When the determination in step 1102 concludes that data exists to be received, the base station receives information through a resource allocated for the data, that is, through the data resource in step 1103, and determines the pattern of the pilot signal included in the data resource in step 1105.

**[0057]** In step 1105, the base station determines the pilot pattern of the pilot signal by correlating the pilot signal with pilot pattern #1 and pilot #2, which are already known, by using a correlator, etc. When the pilot signal has pilot pattern #1, the base station determines that the data resource does not include ACK/NACK, and acquires the uplink data and control information through demultiplexing and decoding of the received information. In contrast, when the pilot signal has pilot pattern #2, the base station determines that the data resource includes ACK/NACK, and acquires the uplink data, control information, and ACK/NACK through demultiplexing and decoding of the received information. When the terminal does not clearly inform the base station of whether to transmit ACK/NACK, the base station may determine whether it will receive ACK/NACK, according to whether a downlink scheduler has previously allocated the resource for the downlink data, instead of using the pilot pattern of the pilot signal in step 1105.

**[0058]** When the determination in step 1102 concludes that no data is to be received, the base station determines in step 1104 whether ACK/NACK exists to be received, based on whether a downlink scheduler has previously allocated the resource for the downlink data. When ACK/NACK exists to be received, the base station receives information through the resource (ACK/NACK resource) allocated for ACK/NACK in step 1106, and acquires ACK/NACK by decoding the received information in step 1109. When the determination in step 1104 concludes that no ACK/NACK is to be received, the process is terminated.

**[0059]** Referring to FIG 12, the base station receives a radio signal through a receiver block 1201. Then, a demultiplexer (DEMUX) 1202 demultiplexes the radio signal and then extracts a signal for a specific terminal. At this time, the DEMUX 1202 operates by using a control signal of a scheduler 1215. That is, when a data resource has been allocated to the terminal by the scheduler 1215, the DEMUX 1202 outputs only the data resource information 1204 in the extracted signal. In contrast, when receiving the ACK/NACK without data, the DEMUX 1202 outputs only the ACK/NACK resource information 1212 in the extracted signal. A channel decoder 1213 decodes the ACK/NACK resource information 1212 and outputs the decoded ACK/NACK.

**[0060]** The data resource information 1204 is provided to a pilot determination block 1203 and a demultiplexer (DEMUX) 1205. The pilot determination block 1203 determines the pilot pattern of the pilot signal included in the data resource information 1204, and makes a determination based on the pilot pattern whether the ACK/NACK exists. Based on a result of the determination, a control signal 1216 indicating existence or absence of the ACK/NACK is input to the DEMUX 1205. When the control signal 1216 indicates that the ACK/NACK exists, the DEMUX 1205 demultiplexes the demultiplexed information 1204 again into encoded uplink data 1222, encoded control information 1221, and encoded ACK/NACK 1223. The outputs 1221, 1222, and 1223 of the

DEMUX 1205 are decoded by the channel decoders 1206, 1207, and 1208 and are then output as uplink data 1210, control information 1209, and ACK/NACK 1211.

**[0061]** In contrast, when the control signal 1216 indicates that no ACK/NACK exists, the DEMUX 1205 demultiplexes the demultiplexed information 1204 again into encoded uplink data 1222 and encoded control information 1221. The outputs 1221 and 1222 of the DEMUX 1205 are decoded by the channel decoders 1206 and 1207 and are then output as uplink data 1210 and control information 1209. At this time, the channel decoder 1208 for the ACK/NACK 1211 does not operate.

#### Second Embodiment

**[0062]** According to the second embodiment of the present invention, an ACK/NACK field of one bit or multiple bits is arranged within control information. When ACK/NACK is transmitted together with uplink data, the ACK/NACK is carried by the ACK/NACK field predefined in the control information. Therefore, only the encoded data and encoded control information are multiplexed before resource mapping. The ACK/NACK field is set to have a value indicating ACK or NACK according to success or failure in reception of downlink data when ACK/NACK exists. Otherwise, the ACK/NACK field is set to have a value indicating or the NACK.

**[0063]** FIG 13 shows an operation of a transmitter (terminal) according to the second embodiment of the present invention, and FIG 14 shows the transmitter (terminal). Referring to FIG 13, when the operation of the terminal has started, the terminal determines whether data exists to be transmitted in step 1302. When data exists to be transmitted by the terminal, the terminal is instructed through scheduling of the base station, etc. When the determination in step 1302 concludes that data exists to be transmitted and the base station has allocated a resource for transmission of the data, the terminal determines whether ACK/NACK exists to be transmitted in step 1303. The determination of whether ACK/NACK exists to be transmitted is performed through an HARQ operation for downlink data, and is based on whether the downlink data has been received.

**[0064]** When it has been determined in step 1303 that there is ACK/NACK to be transmitted, the terminal sets ACK/NACK in the ACK/NACK field of control information and multiplexes the data and control information in step 1305. Then, in step 1308, the terminal maps the multiplexed information to the data resource and then transmits the mapped information. In contrast, when it has been determined in step 1303 that no ACK/NACK is to be transmitted, the terminal sets NACK in the ACK/NACK field of control information and multiplexes the data and control information in step 1307. Then, in step 1308, the terminal maps the multiplexed information to the data resource and then transmits the mapped information.

**[0065]** Meanwhile, when the determination in step 1302 concludes that no uplink data is to be transmitted,

the terminal determines whether ACK/NACK exists to be transmitted in step 1304. When ACK/NACK exists to be transmitted, the terminal transmits the ACK/NACK by using a resource allocated for the ACK/NACK, that is, by using the ACK/NACK resource in step 1309. In contrast, when no ACK/NACK is to be transmitted, the process is terminated.

**[0066]** Referring to the transmitter shown in FIG 14, the uplink data 1401 is encoded by a channel encoder 1408 and is then input to a multiplexer (MUX) 1411. In contrast, the ACK/NACK 1402 indicating success or failure in reception of downlink data is transferred through a demultiplexer (DEMUX) 1415 to output path 1417 or output path 1416 according to the control signal 1420 indicating existence or absence of the uplink data 1401. When the uplink data 1401 is not transmitted, the ACK/NACK 1402 transferred to output path 1416 is subjected to encoding, such as repetition encoding by a channel encoder 1406, and is then transmitted using an ACK/NACK resource by an ACK/NACK resource mapper 1410.

**[0067]** When the uplink data 1401 is not transmitted, the ACK/NACK 1402 transferred to output path 1417 is input to the switch 1405. The switch 1405 selects between a predetermined NACK 1404 and the ACK/NACK 1402. Specifically, the switch 1405 selects the ACK/NACK 1402 when the ACK/NACK 1402 exists in output path 1417, and selects the NACK 1404 when the ACK/NACK 1402 does not exist in output path 1417.

**[0068]** The output of the switch 1405 is multiplexed with control information 1403 by a MUX 1409, and the multiplexed information is encoded by a channel encoder 1407 and is then input to the multiplexer (MUX) 1411. The MUX 1411 multiplexes the data encoded by the channel encoder 1408 and the control information encoded by the channel encoder 1407, and the multiplexed information is then transmitted using the data resource by a data resource mapper 1412.

**[0069]** In the transmitter as described above, when uplink data exists, the ACK/NACK is encoded and transmitted together with control information. At this time, the control information including the ACK/NACK uses a superior decoding performance than the control information that does not include the ACK/NACK. This is because an error requirement of the control information is usually lower than an error requirement of the ACK/NACK. In the structure shown in FIG 14, the control information and the ACK/NACK are simultaneously encoded by one channel encoder 1407, and the channel encoder 1407 operates in accordance with the lower error requirement of the ACK/NACK.

**[0070]** When the channel encoding scheme of the control information including the ACK/NACK has a characteristic of unequal error protection, information bits input to the channel encoder 1407 have different error probabilities according to their positions. Therefore, by locating the ACK/NACK field at a position capable of minimizing the error probability within the control information, it is

possible to satisfy both the error requirement of the ACK/NACK and the error requirement of the control information. For example, section 4.7.1.2 of 3GPP TS 25.212 v6.6.0 describes a channel encoding scheme having an unequal error protection property which can cause the Most Significant Bit (MSB) to have the lowest error probability. Therefore, when the described channel encoding scheme is used, it is possible to lower the error probability of the ACK/NACK and to properly maintain the error probability of the control information by setting the ACK/NACK field as the MSB within the control information and by using proper transmission power.

**[0071]** FIG 15 shows an operation of a receiver (base station) according to the second embodiment of the present invention, and FIG 16 shows the receiver (base station). Referring to FIG 15, when the operation of the base station has started, the base station determines whether the base station will receive data from the terminal in step 1502. The determination of whether the base station will receive data from the terminal is based on whether the base station has allocated a data resource for uplink to the terminal. When the determination in step 1502 concludes that data exists to be received, the base station receives information through a resource allocated for the data, that is, through the data resource in step 1503, decodes control information included in the data resource in step 1504, and obtains the ACK/NACK by reading the ACK/NACK field included in the control information in step 1505.

**[0072]** In contrast, when the determination in step 1502 concludes that no data is to be received, the base station determines in step 1506 whether ACK/NACK exists to be received. When ACK/NACK exists to be received, the base station receives information through the resource (ACK/NACK resource) allocated for the ACK/NACK in step 1507, and acquires ACK/NACK by decoding the received information in step 1508. When the determination in step 1506 concludes that no ACK/NACK is to be received, the process is terminated.

**[0073]** Referring to FIG 16, the base station receives a radio signal through a receiver block 1601. Then, a demultiplexer (DEMUX) 1602 demultiplexes the radio signal and then extracts a signal for a specific terminal. At this time, the DEMUX 1602 operates by using a control signal of a base station scheduler 1603. That is, when a data resource has been allocated to the terminal by the scheduler 1603, the DEMUX 1602 outputs only the data resource information 1604 in the extracted signal. In contrast, when receiving the ACK/NACK without data, the DEMUX 1602 outputs only the ACK/NACK resource information 1605 in the extracted signal. A channel decoder 1613 decodes the ACK/NACK resource information 1605 and outputs the decoded ACK/NACK 1614.

**[0074]** The data resource information 1604 is demultiplexed into encoded data and encoded control information by a demultiplexer 1606. A channel decoder 1607 obtains the uplink data 1609 by decoding the encoded data. Further, a channel decoder 1608 decodes the en-

coded control information, and a demultiplexer 1610 demultiplexes the decoded information and separately outputs pure control information 1611 and the ACK/NACK 1612.

### Third Embodiment

**[0075]** Hereinafter, a third embodiment of the present invention will be described for a case where the ACK/NACK and the CQI, which are uplink signaling information of uplink data to be transmitted, are multiplexed at the same time, and the uplink data is transmitted at a separate time from that for the uplink signaling information.

**[0076]** FIG 17 shows a sub-frame according to the third embodiment of the present invention in which the ACK/NACK and the CQI are multiplexed at the same time. One sub-frame 1708 includes five long blocks LB#1 ~ LB#5, four short blocks SB#1, SB#2, SB#3, SB#4, and CPs 511 and 512 located before the blocks one before one. In comparison with the sub-frame shown in FIG 5, one long block 503 is replaced by two short blocks SB#1, SB#2 1700 and 1702 in the sub-frame shown in FIG 17.

**[0077]** For example, SB#1 1700 carries ACK/NACK and CQI, and SB#2 1702 carries a pilot used in order to demodulate the ACK/NACK and CQI. Further, the other blocks 1706 carry uplink data, control information, and other information. A pilot used for demodulation of the uplink data can be transmitted through SB#3 or SB#4.

**[0078]** FIG 18 shows an example of mapping of the ACK/NACK and the CQI in the frequency domain, which are carried by SB#1 1800 and SB#2 1802 in the sub-frame shown in FIG 17. In FIG 18, the horizontal axis indicates logical mapping of frequency resources 1808. As shown, N number of ACK/NACK channels (ACKCHs) 1804 and K number of CQI channels (CQICHs) 1806 are allocated to the frequency resources of SB#1 1800. According to the applied transmission scheme from among the IFDMA scheme and the LFDMA scheme, the ACK and CQI channels may use a sub-carrier set including discontinuous sub-carriers as shown in (a) of FIG 4 or continuous sub-carriers as shown in (b) of FIG 4 in the physical frequency domain. In order to transmit the ACK/NACK and/or the CQI, a corresponding terminal multiplexes the ACK/NACK and/or the CQI by using an ACK/NACK channel and/or a CQI channel allocated within a corresponding sub-frame (that is, at the same time).

**[0079]** Therefore, when a terminal simultaneously transmits the ACK/NACK and the CQI, the CQI information transmitted through the CQI channel may have a structure as shown in FIG. 19, in order to enable the ACK/NACK and the CQI to be transmitted by a single sub-carrier.

**[0080]** FIG. 19 shows a structure of CQI information according to the third embodiment of the present invention. Reference numeral 1900 denotes a CQI field, and reference numeral 1902 denotes an ACK/NACK field. Although the ACK/NACK field is expressed to have a size

of 1 bit in FIG. 19, the ACK/NACK field may have a size of multiple bits according to a method of expressing the ACK/NACK and the HARQ transmission scheme, etc.

**[0081]** FIG. 20 shows a process for transmitting ACK/NACK and CQI by a transmitter (terminal) according to the third embodiment of the present invention. Upon starting to operate, the terminal determines whether it is the time to transmit CQI (step 2002). The time to transmit CQI is determined, for example, by a specific short block allocated for a CQI channel within a periodically determined specific sub-frame. When it is the time to transmit CQI, the terminal proceeds to step 2003 in which the terminal determines whether ACK/NACK exists to be transmitted.

**[0082]** When the determination in step 2003 concludes that it is necessary to simultaneously transmit both the CQI and the ACK/NACK, the terminal sets a value of ACK/NACK in the ACK/NACK field within the CQI information and sets a CQI value in the CQI field in step 2010. Then, the terminal proceeds to step 2014, in which the terminal channel-encodes both the CQI field and the ACK/NACK field and performs single-carrier transmission through a frequency-time resource (hereinafter, referred to as "CQI resource") allocated to the CQI channel.

**[0083]** When the determination in step 2003 concludes that no ACK/NACK is to be transmitted or it is not the time to transmit the ACK/NACK, the terminal sets NACK in the ACK/NACK field within the CQI information and sets a CQI value in the CQI field in step 2012. Then, the terminal proceeds to step 2014, in which the terminal channel-encodes the CQI information including both the CQI field and the ACK/NACK field and performs the single-carrier transmission.

**[0084]** Meanwhile, when the determination in step 2002 concludes that it is not the time to transmit CQI, the terminal determines whether ACK/NACK exists to be transmitted in step 2004. When ACK/NACK exists to be transmitted and it is the time to transmit the ACK/NACK, the terminal sets a value of ACK/NACK in the ACK/NACK information to be transmitted through the ACK/NACK channel in step 2018. Then, in step 2020, the terminal encodes the ACK/NACK information and then performs single-carrier transmission through a frequency-time resource (hereinafter, referred to as "ACK/NACK resource") allocated to the ACK channel. When the determination in step 2004 concludes that no ACK/NACK is to be transmitted, the process is terminated.

**[0085]** FIG. 21 shows an operation of a receiver (base station) according to the third embodiment of the present invention.

**[0086]** According to the third embodiment of the present invention, when only the CQI without the ACK/NACK is transmitted, the ACK/NACK field within the CQI information is set as NACK. Therefore, the receiver (base station) can improve the decoding performance of the CQI decoding by setting the NACK value with a value which the receiver has already known. This method can be also applied when decoding the control information

according to the second embodiment of the present invention.

**[0087]** Upon starting to operate, the terminal determines whether it is the time to receive CQI information from the terminal in step 2102. When it is the time to receive CQI information from the terminal, the base station proceeds to step 2103 in which the base station receives the CQI information through a CQI resource. Then, in step 2105, the base station determines whether ACK/NACK exists to be received. Then, when ACK/NACK exists to be received and it is the time to receive the ACK/NACK, the base station proceeds to step 2107 in which the base station decodes the CQI field and the ACK/NACK field included in the CQI information. Then, in step 2109, the base station determines the ACK/NACK and the CQI.

**[0088]** In contrast, when no ACK/NACK is to be received or it is not the time to receive the ACK/NACK, the base station sets a field value of NACK in the ACK/NACK field within the CQI information in step 2112. Then, in step 2114, the base station decodes the CQI field included in the CQI information, thereby determining the CQI. In step 2112, the base station may forcibly set the field value of NACK in the ACK/NACK field.

**[0089]** Meanwhile, when the determination in step 2102 concludes that it is not the time to receive the CQI information, the base station determines whether ACK/NACK exists to be received in step 2104. When ACK/NACK exists to be received and it is the time to receive the ACK/NACK, the base station receives the ACK/NACK information through a resource allocated for the ACK/NACK channel, that is, through the ACK/NACK resource in step 2120. Then, in step 2122, the base station decodes the received ACK/NACK, thereby acquiring the ACK/NACK. When the determination in step 2104 concludes that no ACK/NACK is to be received, the process is terminated.

**[0090]** The present invention presents a scheme for multiplexing and resource mapping of uplink data and uplink signaling information, in order to satisfy the single sub-carrier characteristic in the transmission of the uplink data and uplink signaling information in an SC-FDMA wireless communication system. The present invention can eliminate factors disturbing the single carrier transmission and prevent PAPR increase, which may occur when uplink data occurring according to determination of a scheduler, ACK/NACK occurring according to transmission of downlink data, and uplink signaling information such as CQI indicating the channel status are transmitted without relation to each other.

**[0091]** While the invention has been shown and described with reference to certain preferred embodiments thereof, it will be understood by those skilled in the art that various changes in form and details may be made therein without departing from the spirit and scope of the invention as defined by the appended claims.

## Claims

1. A method for transmitting multiple types of uplink information in a Single Carrier Frequency Division Multiple Access (SC-FDMA) wireless communication system, the method comprising the steps of:

determining whether uplink signaling information exists to be transmitted when uplink data exists to be transmitted;  
multiplexing the uplink data and control information for the uplink data and transmitting multiplexed data through a first frequency resource allocated for the uplink data when no uplink signaling information exists;  
multiplexing the uplink data, control information for the uplink data, and the uplink signaling information, and transmitting multiplexed data through a first frequency resource allocated for the uplink data when uplink signaling information exists; and  
transmitting the uplink signaling information through a second frequency resource allocated for the uplink signaling information when no uplink data is to be transmitted and uplink signaling information exists to be transmitted.

2. The method as claimed in claim 1, further comprising transmitting a pilot having a predetermined first pilot pattern, which indicates that no uplink signaling information is to be transmitted, through a predetermined time resource of the first frequency resource.

3. The method as claimed in claim 2, further comprising transmitting a pilot having a predetermined second pilot pattern, which indicates that uplink signaling information exists to be transmitted, through a predetermined time resource of the first frequency resource.

4. The method as claimed in claim 1, wherein the uplink signaling information is included in an uplink signaling field within the control information.

5. The method as claimed in claim 4, wherein the uplink signaling field within the control information is set to have a predetermined value when no uplink signaling information is to transmit.

6. The method as claimed in claim 1, wherein the uplink signaling information includes at least one of ACK/NACK, which indicates success or failure in reception of downlink data, and a Channel Quality Indicator (CQI), which indicates a status of a channel.

7. The method as claimed in claim 6, wherein the ACK/NACK and the CQI are transmitted using sub-carriers allocated for the CQI within a predetermined time



resource when the uplink signaling information to be transmitted includes both the ACK/NACK and the CQI.

8. The method as claimed in claim 7, wherein one of the ACK/NACK and the CQI is transmitted using one of a first sub-carrier set allocated for the CQI and a second sub-carrier set allocated for the ACK/NACK within the time resource when the uplink signaling information to be transmitted includes one of the ACK/NACK and the CQI.

9. The method as claimed in claim 8, wherein each of the first sub-carrier set and the second sub-carrier set includes sub-carriers having equal intervals between them.

10. The method as claimed in claim 1, wherein the first sub-carrier set and the second sub-carrier set include sub-carriers having equal intervals or between them or sub-carriers adjacent to each other.

11. An apparatus for transmitting multiple types of uplink information in a Single Carrier Frequency Division Multiple Access (SC-FDMA) wireless communication system, the apparatus comprising:

a multiplexer for multiplexing uplink data and control information for the uplink data when uplink data exists to be transmitted and no uplink signaling information is to be transmitted, and multiplexing uplink data, control information for the uplink data, and the uplink signaling information when both the uplink data exists to be transmitted and the uplink signaling information exists to be transmitted;

a data resource mapper for transmitting information multiplexed by the multiplexer through a first frequency resource allocated for the uplink data; and

an uplink signaling resource mapper for transmitting the uplink signaling information through a second frequency resource allocated for the uplink signaling information, when no uplink data is to be transmitted.

12. The apparatus as claimed in claim 11, wherein the multiplexer transmits a pilot having a predetermined first pilot pattern, which indicates that no uplink signaling information is to be transmitted, through a predetermined time resource of the first frequency resource.

13. The apparatus as claimed in claim 12, wherein the multiplexer transmits a pilot having a predetermined second pilot pattern, which indicates that the uplink signaling information is to be transmitted, through a predetermined time resource of the first frequency

resource.

14. The apparatus as claimed in claim 11, wherein the uplink signaling information is included in an uplink signaling field within the control information.

15. The apparatus as claimed in claim 14, wherein the uplink signaling field within the control information is set to have a predetermined value when no uplink signaling information is to transmit.

16. The apparatus as claimed in claim 11, wherein the uplink signaling information includes at least one of ACKnowledgement/Negative ACKnowledgement (ACK/NACK), which indicates success or failure in reception of downlink data, and a Channel Quality Indicator (CQI), which indicates a status of a channel.

17. The apparatus as claimed in claim 16, wherein the ACK/NACK and the CQI are transmitted using sub-carriers allocated for the CQI within a predetermined time resource when the uplink signaling information to be transmitted includes both the ACK/NACK and the CQI.

18. The apparatus as claimed in claim 17, wherein one of the ACK/NACK and the CQI is transmitted using one of a first sub-carrier set allocated for the CQI and a second sub-carrier set allocated for the ACK/NACK within the time resource, when the uplink signaling information to be transmitted includes one of the ACK/NACK and the CQI.

19. The apparatus as claimed in claim 18, wherein each of the first sub-carrier set and the second sub-carrier set includes sub-carriers having equal intervals between them.

20. The apparatus as claimed in claim 11, wherein the first sub-carrier set and the second sub-carrier set include sub-carriers having equal intervals or between them or sub-carriers adjacent to each other.

21. A method for receiving multiple types of uplink information in a Single Carrier Frequency Division Multiple Access (SC-FDMA) wireless communication system, the method comprising the steps of:

(1) determining whether uplink data has been received through a first frequency resource allocated for the uplink data;

(2) determining whether information received through the first frequency resource includes uplink signaling information, when the uplink data has been received;

(3) demultiplexing the information received through the first frequency resource into the up-

- link data and control information for the uplink data, when the information received through the first frequency resource does not include uplink signaling information;
- (4) demultiplexing the information received through the first frequency resource into the uplink data, control information for the uplink data, and uplink signaling information, when the information received through the first frequency resource includes the uplink signaling information; and
- (5) receiving the uplink signaling information through a second frequency resource allocated for the uplink signaling information, when the uplink data has not been received.
22. The method as claimed in claim 21, wherein determining in step (2) is based on a pilot pattern of a pilot for the uplink data, which is received through a predetermined time resource of the first frequency resource.
23. The method as claimed in claim 22, wherein the pilot has one of a predetermined first pilot pattern, which indicates that no uplink signaling information exists, and a predetermined second pilot pattern, which indicates that the uplink signaling information exists.
24. The method as claimed in claim 21, wherein the uplink signaling information is included in an uplink signaling field within the control information.
25. The method as claimed in claim 24, wherein the uplink signaling field within the control information is set to have a predetermined value when no uplink signaling information exists.
26. The method as claimed in claim 21, wherein the uplink signaling information includes at least one of ACKnowledgement/Negative ACKnowledgement (ACK/NACK), which indicates success or failure in reception of downlink data, and a Channel Quality Indicator (CQI), which indicates a status of a channel.
27. The method as claimed in claim 26, wherein the ACK/NACK and the CQI are received using sub-carriers allocated for the CQI within a predetermined time resource when the uplink signaling information includes both the ACK/NACK and the CQI.
28. The method as claimed in claim 27, wherein one of the ACK/NACK and the CQI is received using one of a first sub-carrier set allocated for the CQI and a second sub-carrier set allocated for the ACK/NACK within the time resource when the uplink signaling information includes one of the ACK/NACK and the CQI.
29. The method as claimed in claim 28, wherein each of the first sub-carrier set and the second sub-carrier set includes sub-carriers having equal intervals between them.
30. The method as claimed in claim 21, wherein the first sub-carrier set and the second sub-carrier set include sub-carriers having equal intervals between them or sub-carriers adjacent to each other.
31. An apparatus for receiving multiple types of uplink information in a Single Carrier Frequency Division Multiple Access (SC-FDMA) wireless communication system, the apparatus comprising:
- a determination unit for determining whether information includes uplink signaling information, when the information has been received through a first frequency resource allocated for uplink data;
- a demultiplexer for demultiplexing the information received through the first frequency resource into the uplink data and control information for the uplink data when the information received through the first frequency resource does not include uplink signaling information, and demultiplexing the information received through the first frequency resource into the uplink data, control information for the uplink data, and uplink signaling information, when the information received through the first frequency resource includes the uplink signaling information; and
- a receiver unit for receiving the uplink signaling information through a second frequency resource allocated for the uplink signaling information, when no information is received through the first frequency resource.
32. The apparatus as claimed in claim 31, wherein determination by the determination unit is based on a pilot pattern of a pilot for the uplink data, which is received through a predetermined time resource of the first frequency resource.
33. The apparatus as claimed in claim 32, wherein the pilot has one of a predetermined first pilot pattern, which indicates that no uplink signaling information exists, and a predetermined second pilot pattern, which indicates that the uplink signaling information exists.
34. The apparatus as claimed in claim 31, wherein the uplink signaling information is included in an uplink signaling field within the control information.
35. The apparatus as claimed in claim 34, wherein the uplink signaling field within the control information is set to have a predetermined value when there is no

uplink signaling information.

- 36. The apparatus as claimed in claim 31, wherein the uplink signaling information includes at least one of ACKnowledgement/Negative ACKnowledgement (ACK/NACK), which indicates success or failure in reception of downlink data, and a Channel Quality Indicator (CQI), which indicates a status of a channel. 5
- 37. The apparatus as claimed in claim 36, wherein the ACK/NACK and the CQI are received using sub-carriers allocated for the CQI within a predetermined time resource when the uplink signaling information includes both the ACK/NACK and the CQI. 10
- 38. The apparatus as claimed in claim 37, wherein one of the ACK/NACK and the CQI is received using one of a first sub-carrier set allocated for the CQI and a second sub-carrier set allocated for the ACK/NACK within the time resource when the uplink signaling information includes one of the ACK/NACK and the CQI. 15
- 39. The apparatus as claimed in claim 38, wherein each of the first sub-carrier set and the second sub-carrier set includes sub-carriers having equal intervals between them. 20
- 40. The apparatus as claimed in claim 31, wherein the first sub-carrier set and the second sub-carrier set include sub-carriers having equal intervals between them or sub-carriers adjacent to each other. 25

30

35

40

45

50

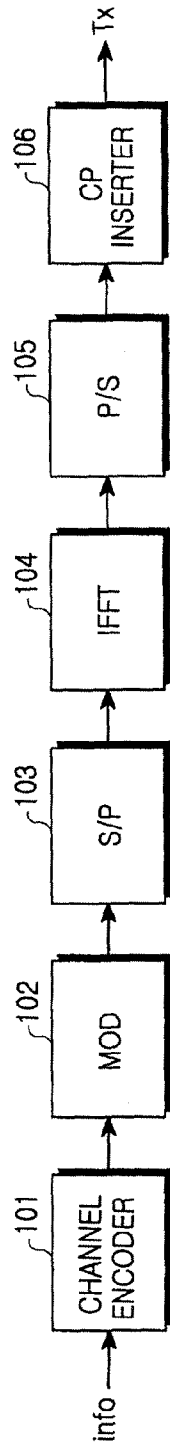

FIG.1

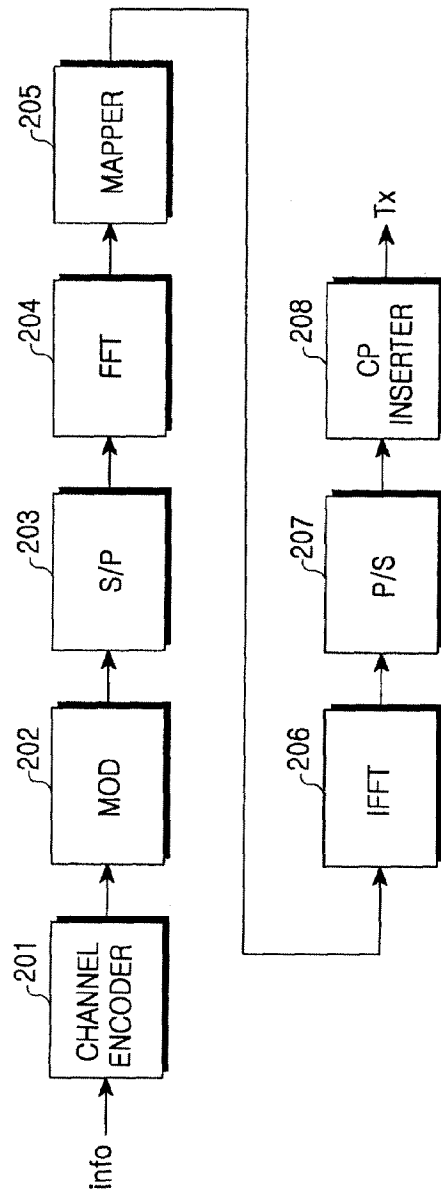

FIG.2

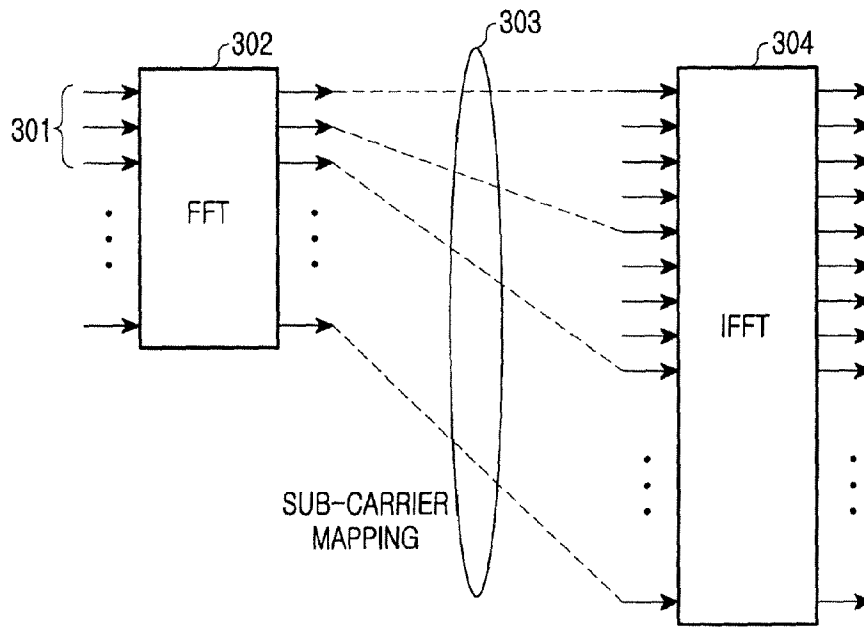

FIG.3

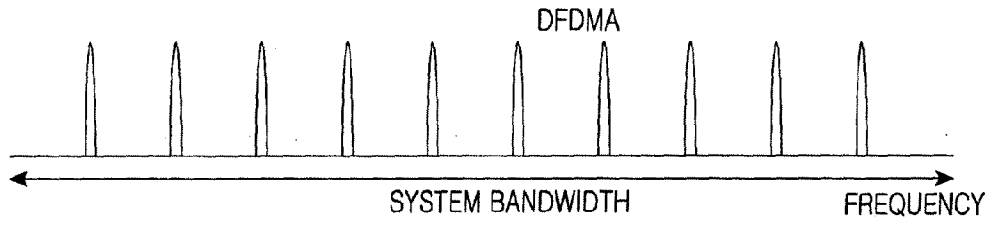

FIG.4A

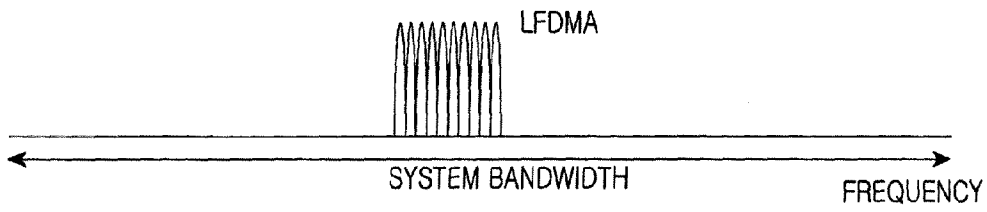

FIG.4B

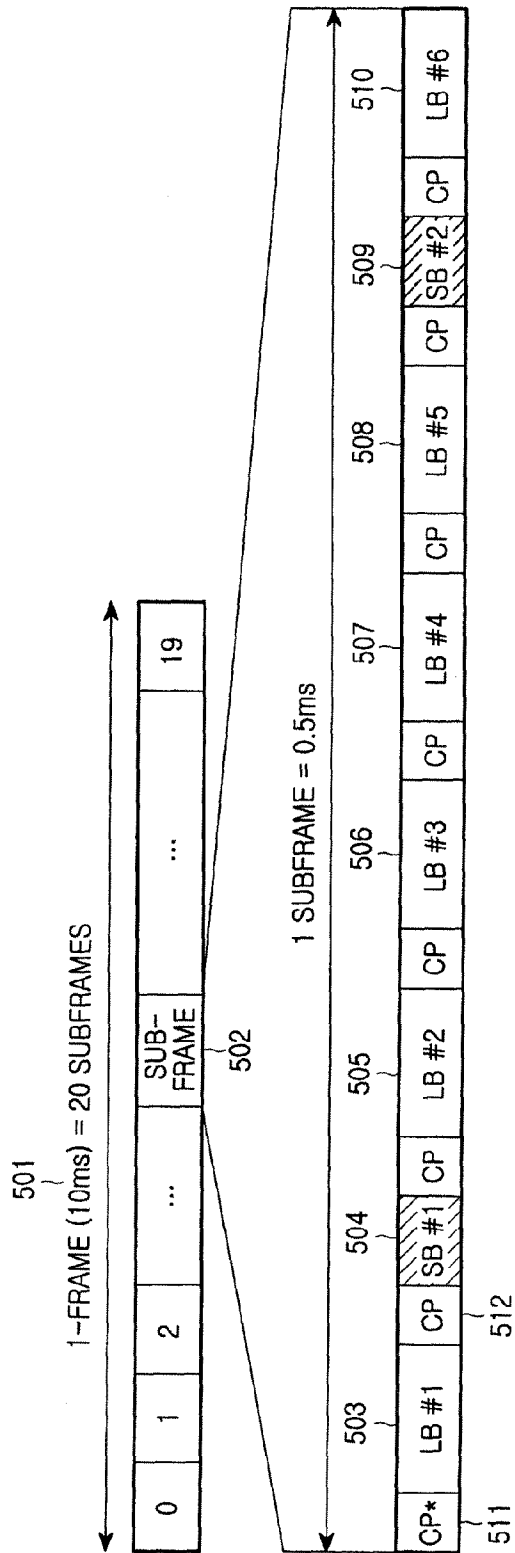

FIG.5



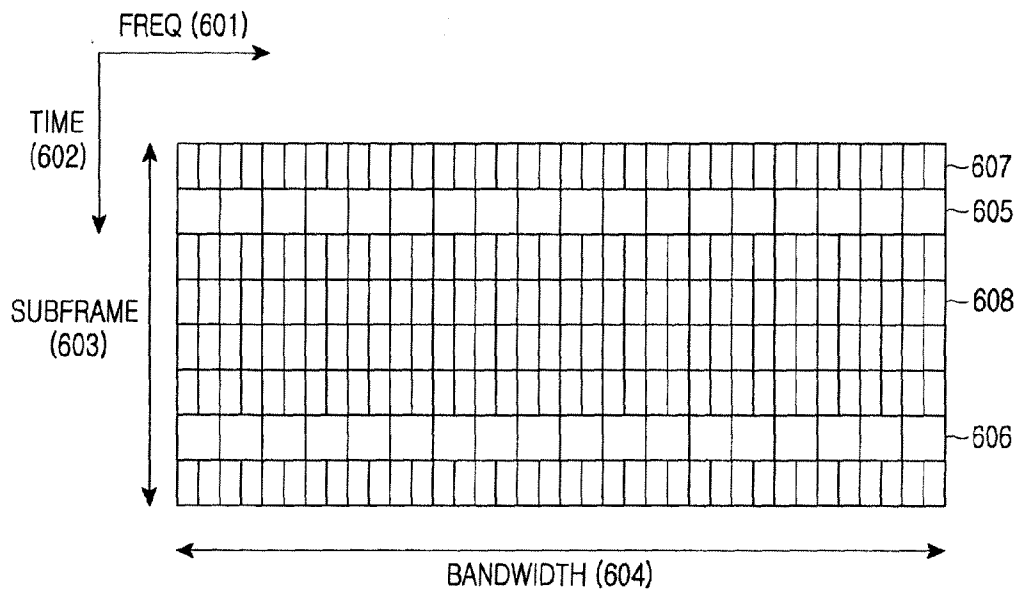

FIG.6

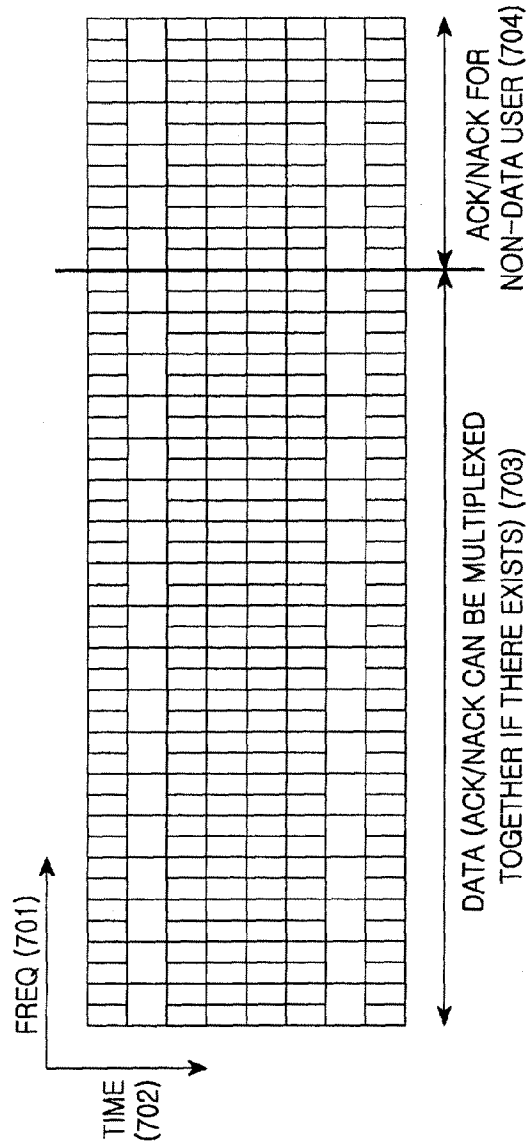

FIG.7

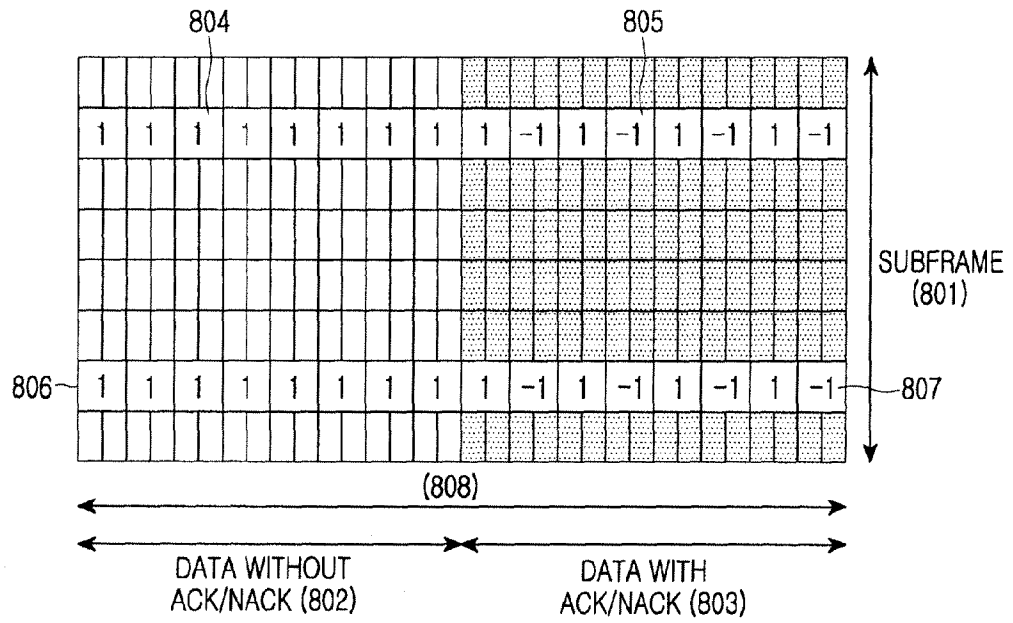

FIG. 8

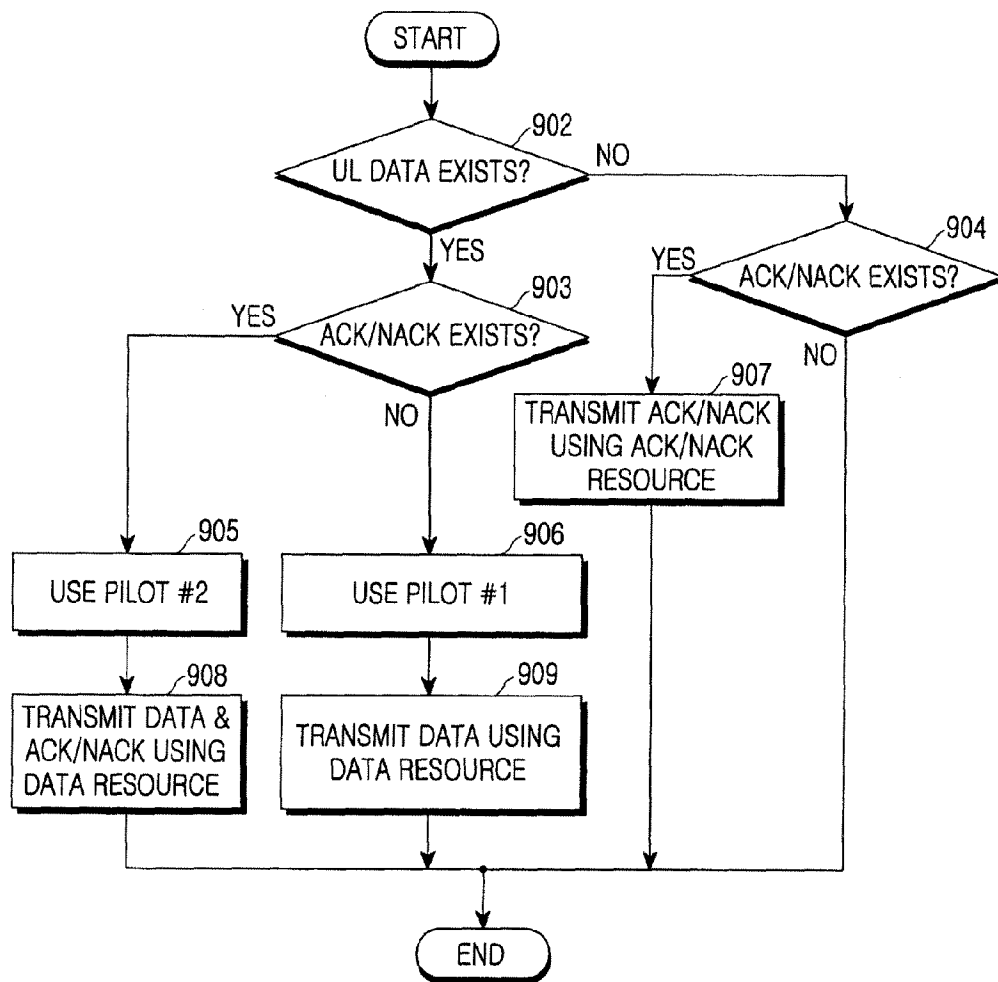

FIG.9

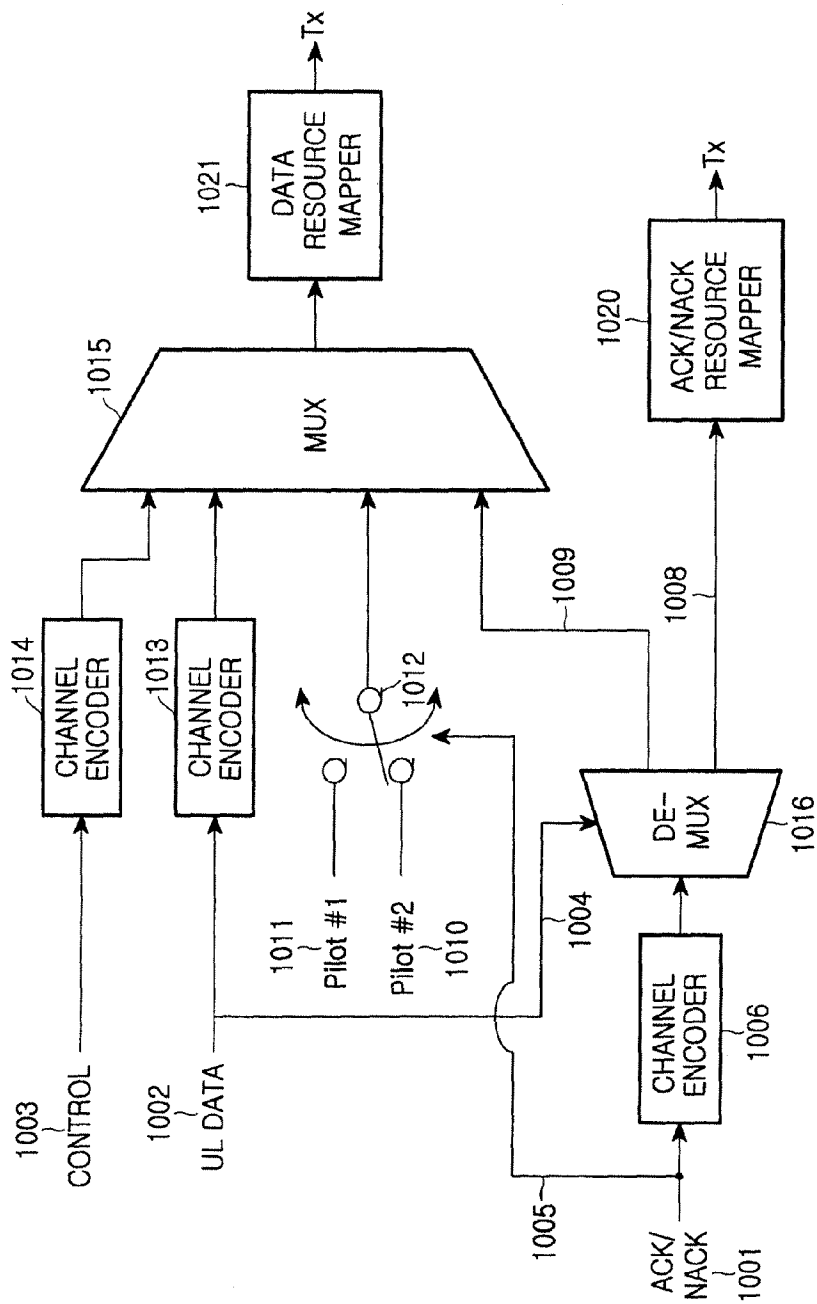

FIG.10

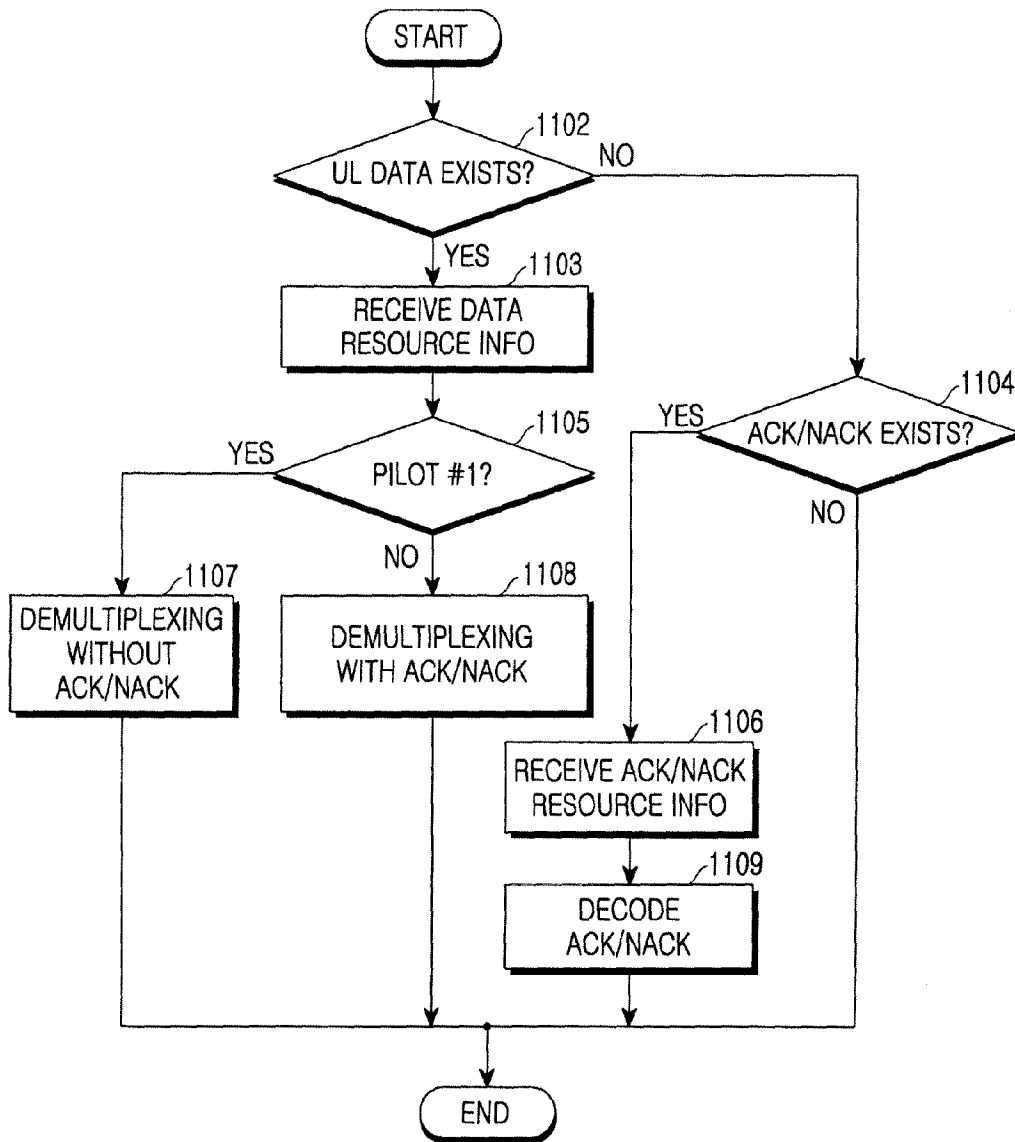

FIG.11

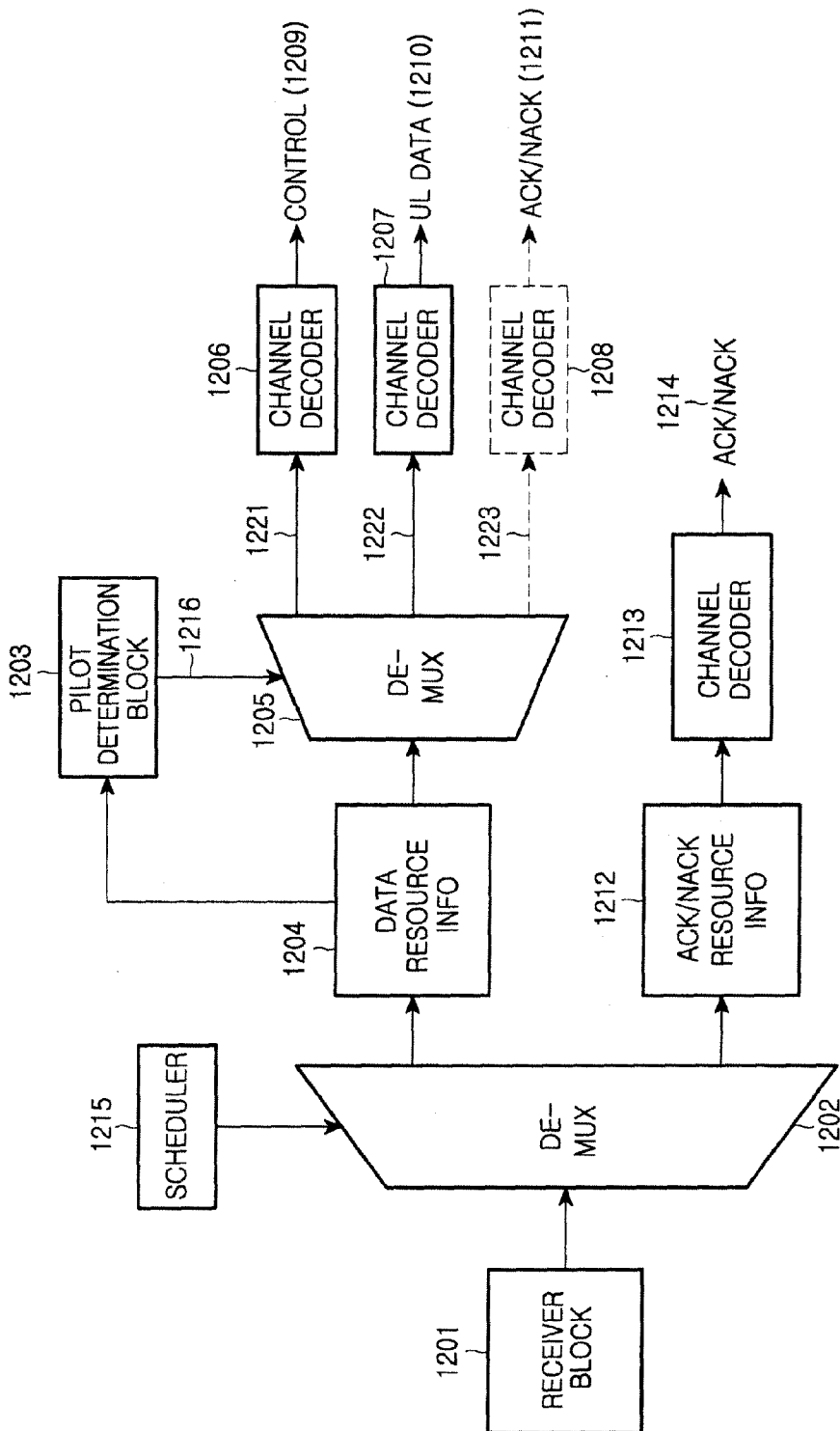

FIG.12

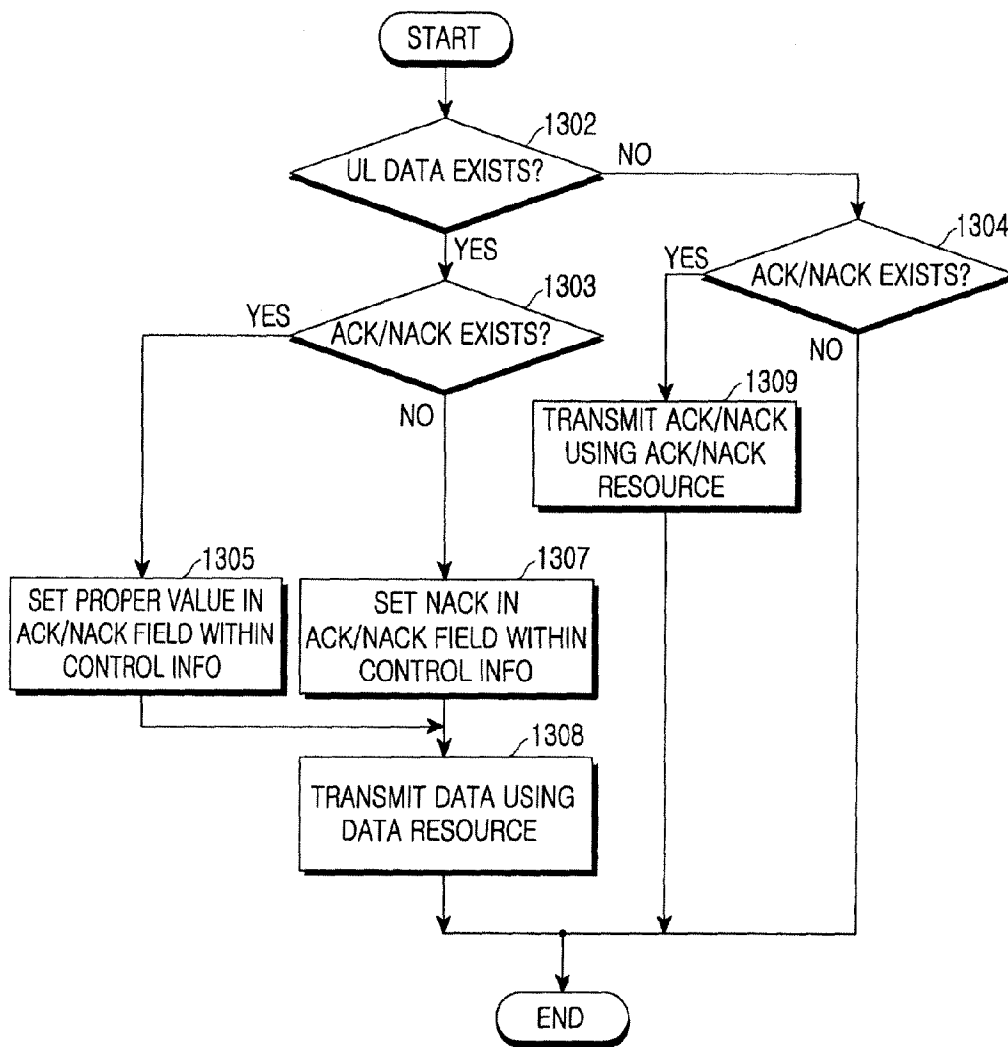

FIG.13



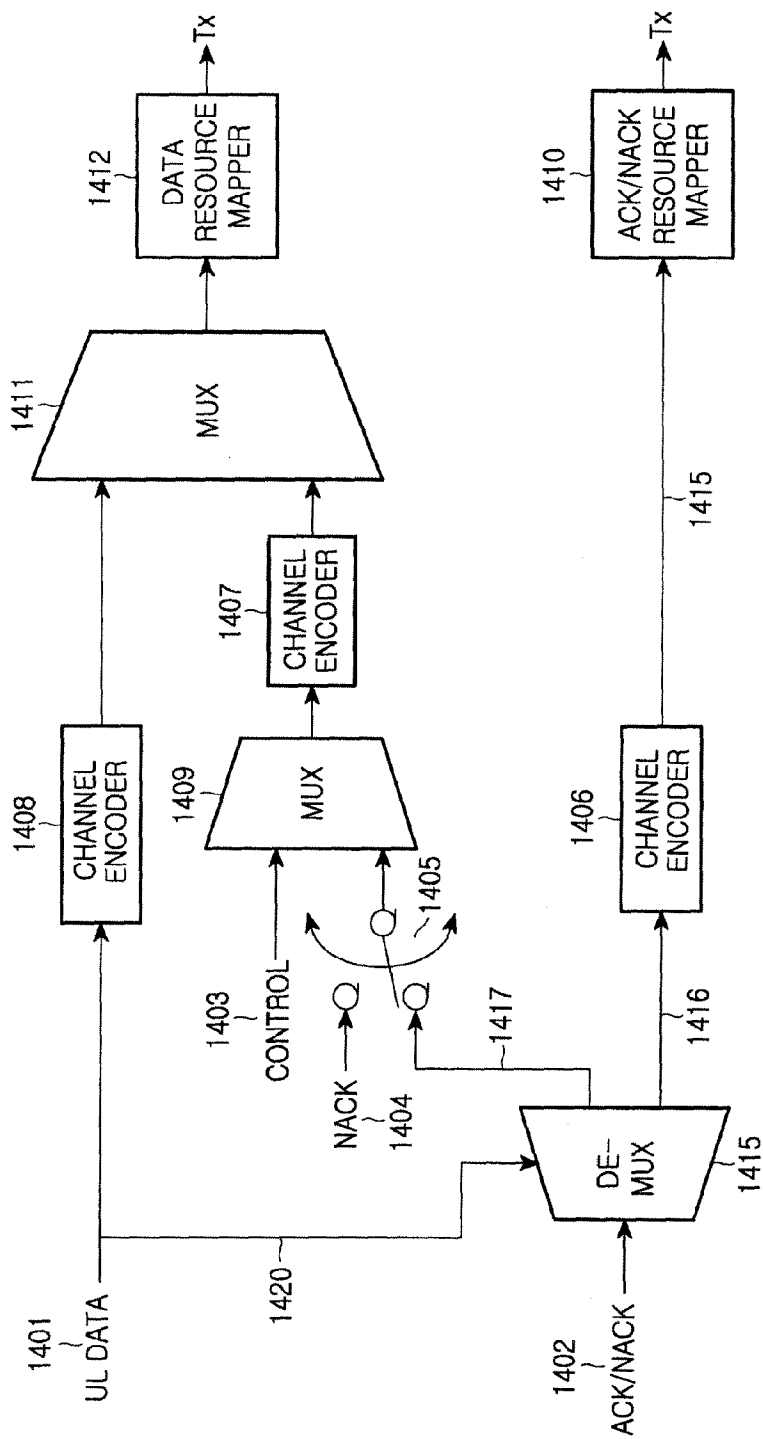

FIG.14

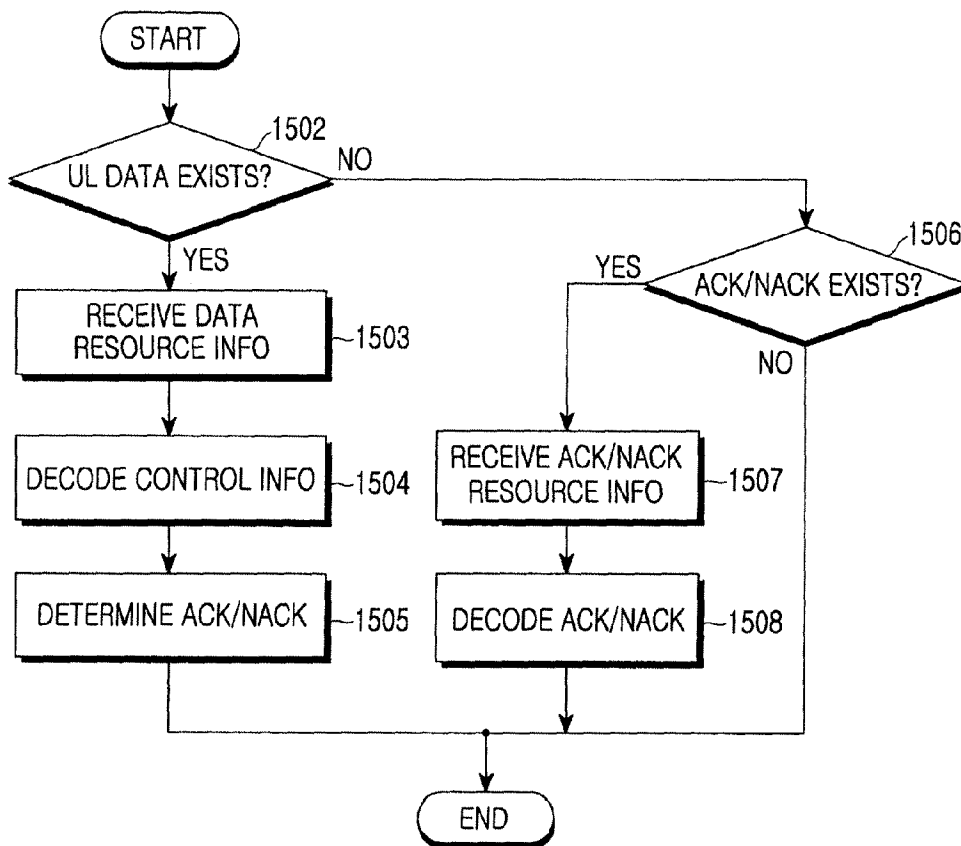

FIG.15

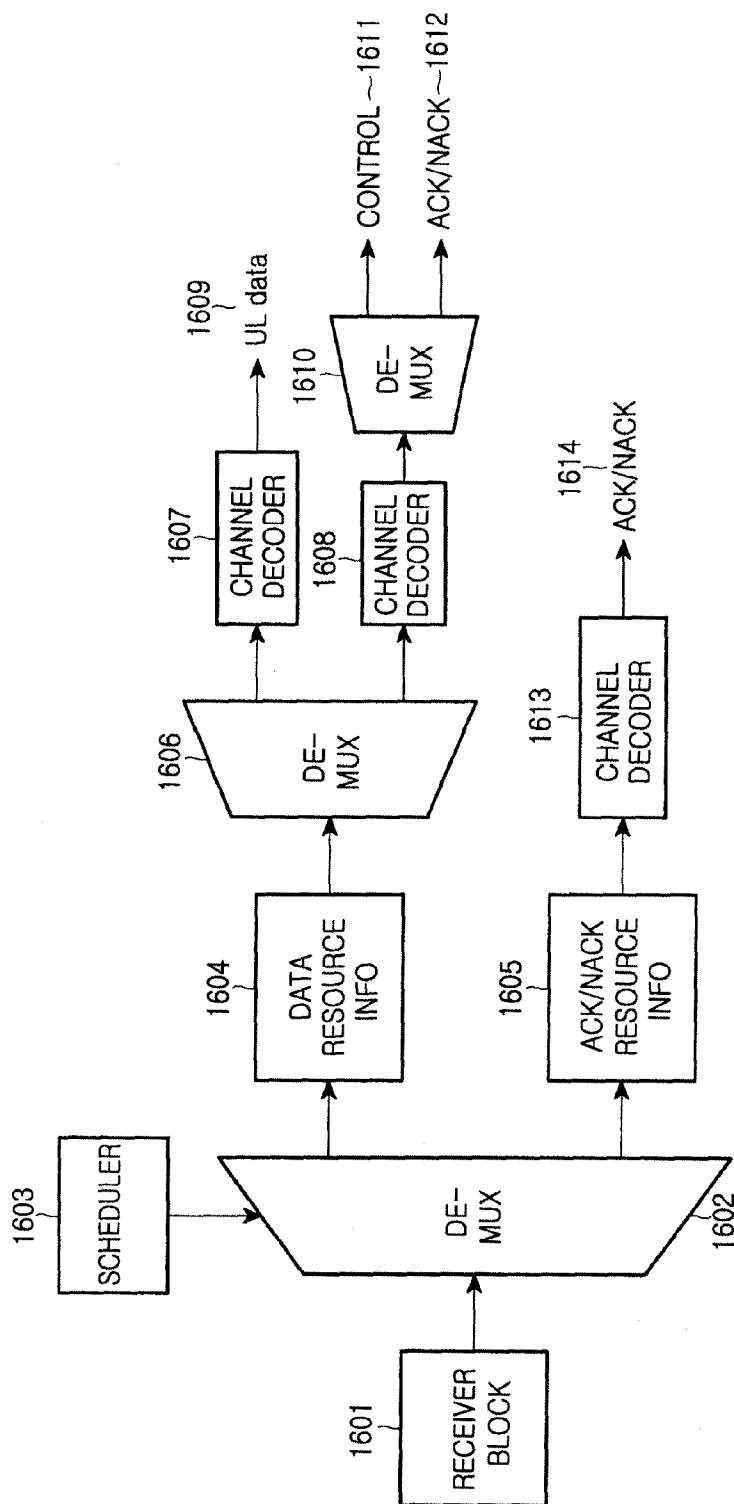

FIG.16

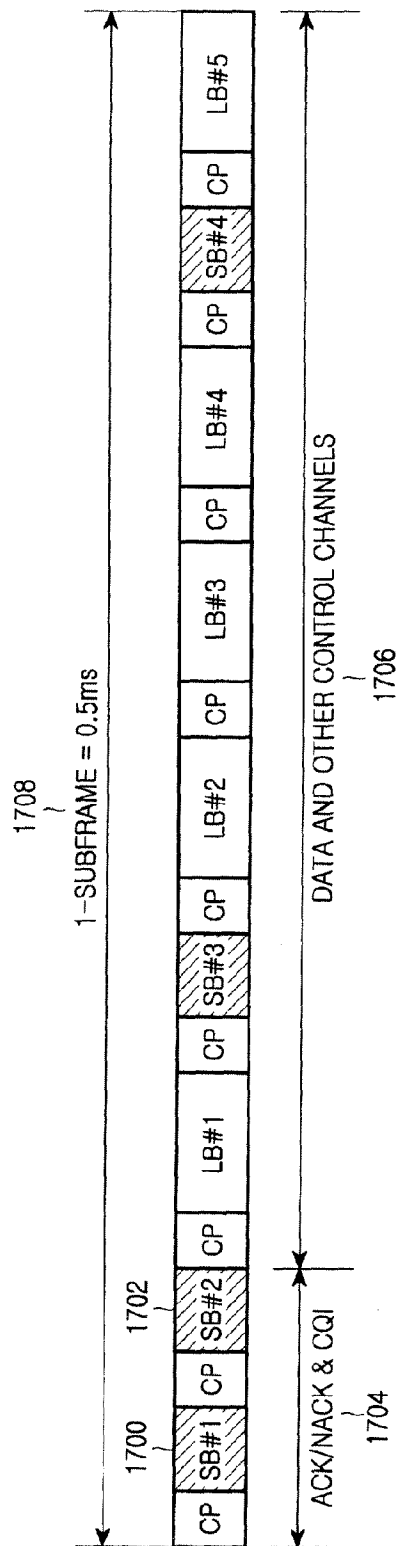

FIG.17

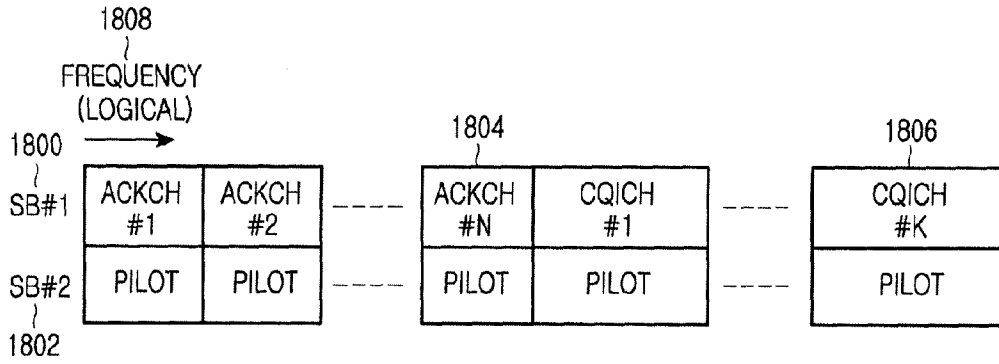

FIG.18

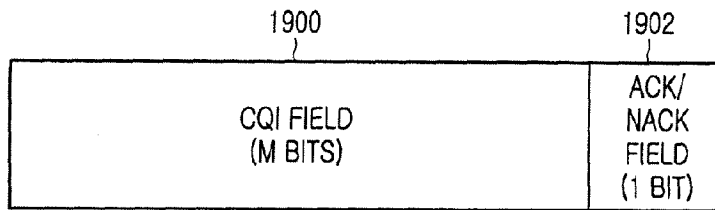

FIG.19

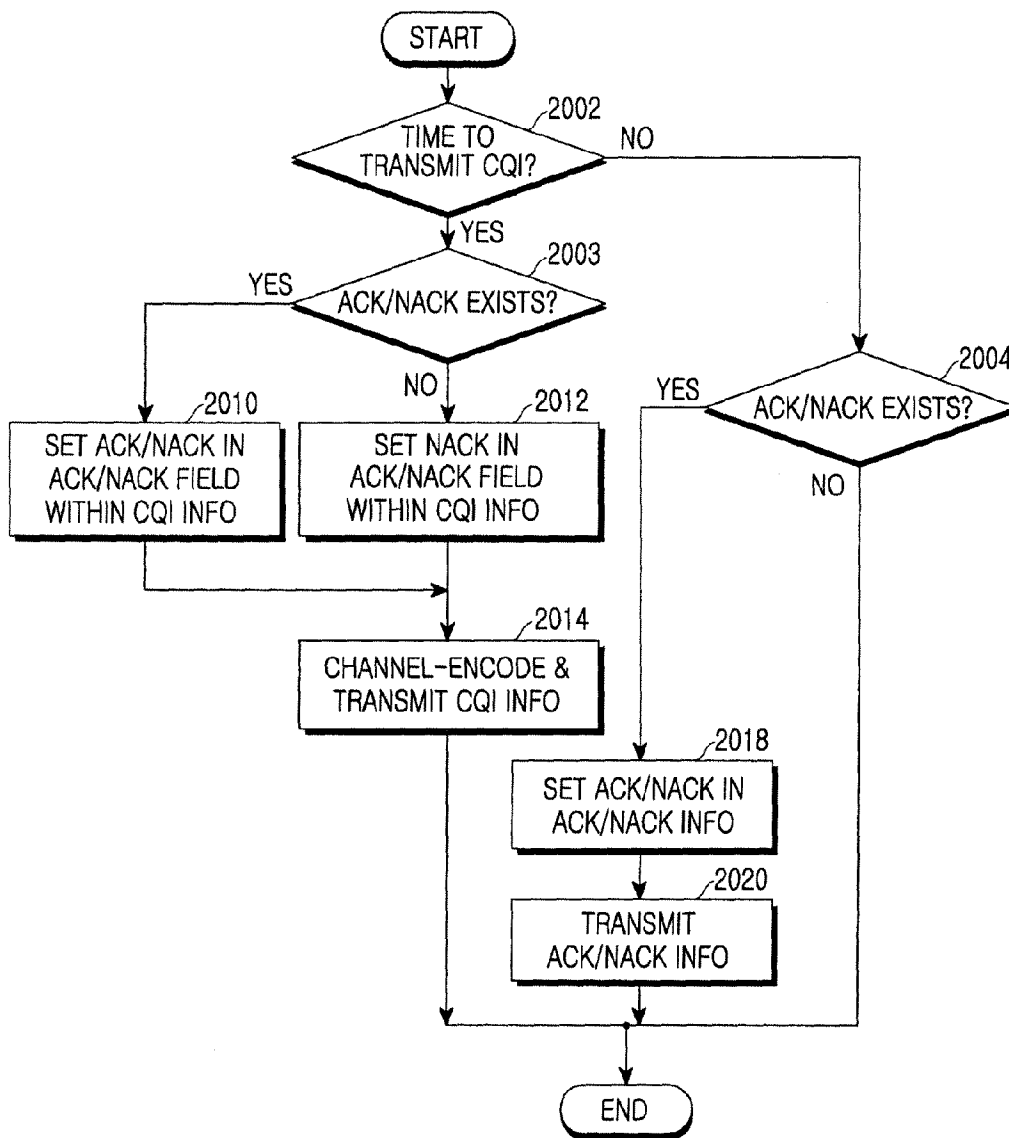

FIG. 20

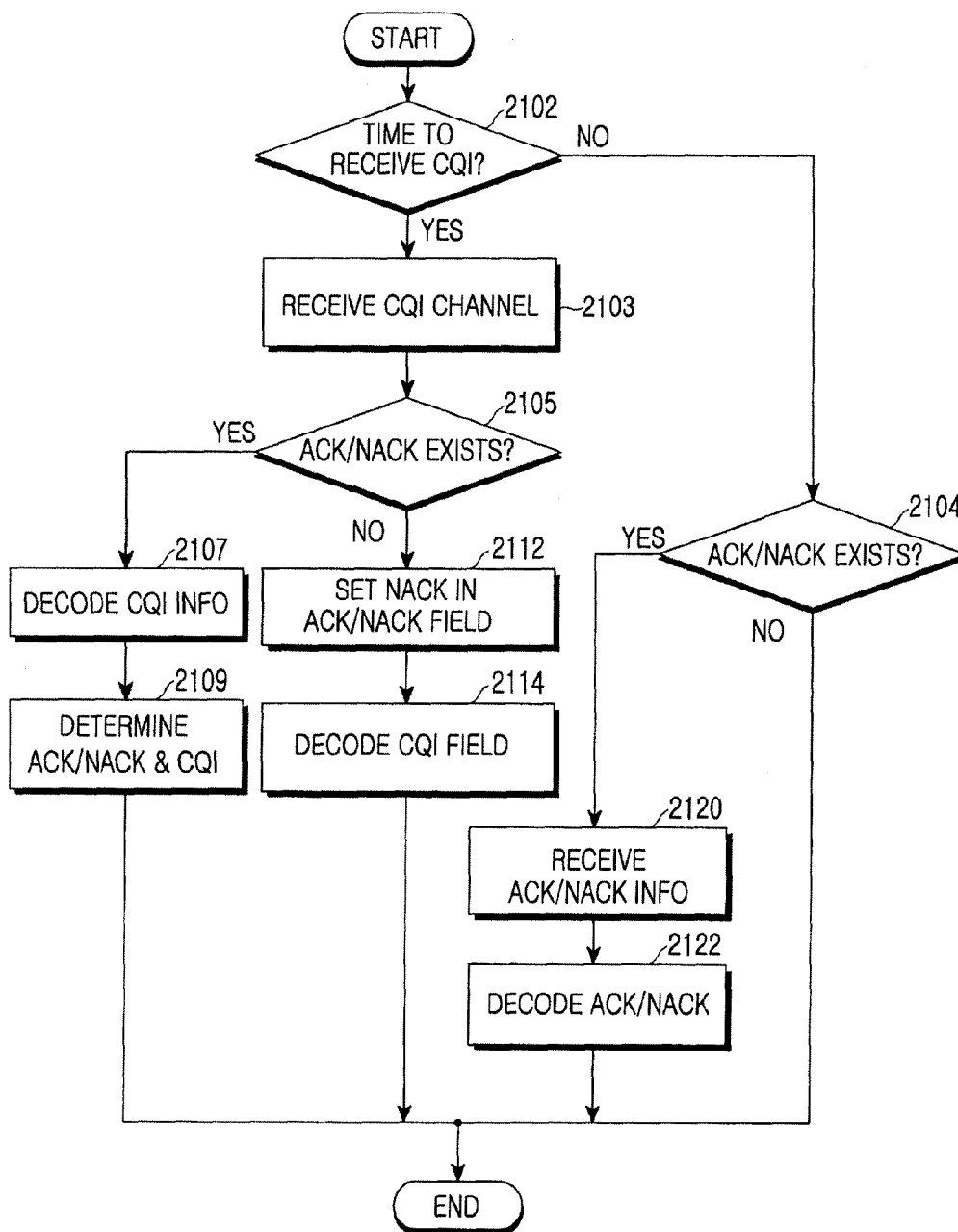

FIG.21

## Electronic Acknowledgement Receipt

<b>EFS ID:</b>	9987735
<b>Application Number:</b>	12209136
<b>International Application Number:</b>	
<b>Confirmation Number:</b>	3897
<b>Title of Invention:</b>	METHOD FOR TRANSMITTING UPLINK SIGNALS
<b>First Named Inventor/Applicant Name:</b>	Dae Won Lee
<b>Customer Number:</b>	35884
<b>Filer:</b>	Rolando Gonzalez/Neeti Rajput
<b>Filer Authorized By:</b>	Rolando Gonzalez
<b>Attorney Docket Number:</b>	2101-3573
<b>Receipt Date:</b>	29-APR-2011
<b>Filing Date:</b>	11-SEP-2008
<b>Time Stamp:</b>	14:54:30
<b>Application Type:</b>	Utility under 35 USC 111(a)

### Payment information:

Submitted with Payment	no
------------------------	----

### File Listing:

Document Number	Document Description	File Name	File Size(Bytes)/ Message Digest	Multi Part /.zip	Pages (if appl.)
1	Information Disclosure Statement (IDS) Filed (SB/08)	2101-3573_040611_IDSform. pdf	612237 <small>cc7044538e953e597c11134a20341ddaec7 dca56</small>	no	4

### Warnings:

### Information:



A U.S. Patent Number Citation or a U.S. Publication Number Citation is required in the Information Disclosure Statement (IDS) form for autoloading of data into USPTO systems. You may remove the form to add the required data in order to correct the Informational Message if you are citing U.S. References. If you chose not to include U.S. References, the image of the form will be processed and be made available within the Image File Wrapper (IFW) system. However, no data will be extracted from this form. Any additional data such as Foreign Patent Documents or Non Patent Literature will be manually reviewed and keyed into USPTO systems.

2	Foreign Reference	F1_EP1569403.pdf	2431441 8b2fca68d3e469173558f17938a18776fdbd b5b8	no	25
<b>Warnings:</b>					
<b>Information:</b>					
3	Foreign Reference	F2_EP1806867.pdf	3724322 2822f5efc0cb967622a60b12ed0be25d5b7 48fba	no	30
<b>Warnings:</b>					
<b>Information:</b>					
4	Foreign Reference	F3_EP1811701.pdf	4013787 10b6206b405c55725132108d34815d616a ddc338	no	34
<b>Warnings:</b>					
<b>Information:</b>					
<b>Total Files Size (in bytes):</b>				10781787	

**This Acknowledgement Receipt evidences receipt on the noted date by the USPTO of the indicated documents, characterized by the applicant, and including page counts, where applicable. It serves as evidence of receipt similar to a Post Card, as described in MPEP 503.**

**New Applications Under 35 U.S.C. 111**

**If a new application is being filed and the application includes the necessary components for a filing date (see 37 CFR 1.53(b)-(d) and MPEP 506), a Filing Receipt (37 CFR 1.54) will be issued in due course and the date shown on this Acknowledgement Receipt will establish the filing date of the application.**

**National Stage of an International Application under 35 U.S.C. 371**

**If a timely submission to enter the national stage of an international application is compliant with the conditions of 35 U.S.C. 371 and other applicable requirements a Form PCT/DO/EO/903 indicating acceptance of the application as a national stage submission under 35 U.S.C. 371 will be issued in addition to the Filing Receipt, in due course.**

**New International Application Filed with the USPTO as a Receiving Office**

**If a new international application is being filed and the international application includes the necessary components for an international filing date (see PCT Article 11 and MPEP 1810), a Notification of the International Application Number and of the International Filing Date (Form PCT/RO/105) will be issued in due course, subject to prescriptions concerning national security, and the date shown on this Acknowledgement Receipt will establish the international filing date of the application.**

Attorney Docket No.: 2101-3573  
Customer No. 035884

**IN THE UNITED STATES PATENT AND TRADEMARK OFFICE**

In re application of:  
Dae Won Lee

Serial No: 12/209,136  
Filed: September 11, 2008  
For: METHOD FOR TRANSMITTING UPLINK  
SIGNALS

Art Unit: 2617

Examiner: Bost, Dwayne D.

Conf. No.: 3897

**PRELIMINARY AMENDMENT**

Mail Stop Amendment  
Commissioner for Patents  
P.O. Box 1450  
Alexandria, VA 22313-1450

Dear Sir:

Prior to initial examination on the merits, please amend the above-identified application as follows below.

IN THE CLAIMS:

Please cancel claims 1-8 without prejudice and add new claims 9-44 as follows:

1-8. (Canceled)

9. (New) A method for transmitting uplink signals comprising control signals and data signals in a wireless communication system, the method comprising:

serially multiplexing first control signals and data signals in a mobile station;

sequentially mapping the multiplexed signals to a time-frequency resource map according to a time-first mapping method, wherein the time-frequency resource map comprises a plurality of symbols and a plurality of subcarriers for each symbol, and a reference signal is mapped to at least one subcarrier corresponding to one of the plurality of symbols; and

mapping ACK/NACK control signals to subcarriers corresponding to symbols near the symbol on which the reference signal is mapped.

10. (New) The method of claim 9, wherein the first control signals comprise at least one of:

precoding matrix index (PMI) signals; or

channel quality indicator (CQI) signals.

11. (New) The method of claim 9, wherein the ACK/NACK control signals are mapped to the subcarriers by overwriting the first control signals or data signals mapped to the subcarriers corresponding to symbols near the symbol on which the reference signal is mapped.

12. (New) The method of claim 9, wherein the reference signal is mapped to at least one subcarrier corresponding to a fourth symbol out of seven symbols in a slot.

13. (New) The method of claim 9, wherein the ACK/NACK control signals are mapped to subcarriers corresponding to symbols on either side of the symbol on which the reference signal is mapped.

14. (New) The method of claim 9, wherein the ACK/NACK control signals are mapped to subcarriers corresponding to a third symbol and a fifth symbol out of seven symbols in a slot.

15. (New) The method of claim 9, wherein the ACK/NACK control signals are channel coded independently of the data signals or first control signals.

16. (New) The method of claim 9, further comprising:

respectively performing for each of the plurality of symbols having mapped multiplexed signals or mapped ACK/NACK control signals, a discrete Fourier transform (DFT) on signals mapped on subcarriers corresponding to the same symbol on the time-frequency resource map;

respectively performing an inverse fast Fourier transform (IFFT) on the DFT-transformed signals mapped on subcarriers corresponding to the same symbol on the time-frequency resource map;

respectively attaching a cyclic prefix to the IFFT-transformed signals mapped on subcarriers corresponding to the same symbol on the time-frequency resource map; and

transmitting each symbol having IFFT-transformed signals with an attached cyclic prefix as a single carrier frequency division multiple access (SC-FDMA) symbol.

17. (New) The method of claim 9, further comprising transmitting the signals mapped to the time-frequency resource map through a physical uplink shared channel (PUSCH).

18. (New) A method for transmitting uplink signals comprising first control signals, ACK/NACK control signals and data signals in a wireless communication system, the method comprising:

channel coding in a mobile station each of the first control signals, the ACK/NACK control signals, and the data signals, wherein the first control signals, the ACK/NACK control signals and the data signals are independently channel coded from each other;

serially multiplexing the channel coded first control signals and the channel coded data signals;

sequentially mapping the multiplexed signals to a time-frequency resource map according to a time-first mapping method, wherein the time-frequency resource map comprises a plurality of symbols and a plurality of subcarriers for each symbol, and a reference signal is mapped to at least one subcarrier corresponding to one of the plurality of symbols; and

mapping the channel coded ACK/NACK control signals to subcarriers corresponding to symbols near the symbol on which the reference signal is mapped.

19. (New) The method of claim 18, wherein channel coding the data signals comprises:

attaching a transport block cyclic redundancy check (CRC) to a transport block for transmitting the data signals;

segmenting the transport block having the attached transport block CRC into at least one code block unit;

attaching a code block CRC to the at least one segmented code block;

performing channel coding on the data attached with the code block CRC; and

performing rate matching and code block concatenation one the channel coded data.

20. (New) The method of claim 18, wherein the first control signals comprise at least one of:

precoding matrix index (PMI) signals; or

channel quality indicator (CQI) signals.

21. (New) The method of claim 18, wherein the channel coded ACK/NACK control signals are mapped to the subcarriers by overwriting the channel coded first control signals or channel coded data signals mapped to the subcarriers corresponding to symbols near the symbol on which the reference signal is mapped.

22. (New) The method of claim 18, wherein the reference signal is mapped to at least one subcarrier corresponding to a fourth symbol out of seven symbols in a slot.

23. (New) The method of claim 18, wherein the channel coded ACK/NACK control signals are mapped to subcarriers corresponding to symbols on either side of the symbol on which the reference signal is mapped.

24. (New) The method of claim 18, wherein the ACK/NACK control signals are mapped to subcarriers corresponding to a third symbol and a fifth symbol out of seven symbols in a slot.

25. (New) The method of claim 18, further comprising:  
respectively performing for each of the plurality of symbols having mapped multiplexed signals or mapped ACK/NACK control signals, a discrete Fourier transform (DFT) on signals mapped on subcarriers corresponding to the same symbol on the time-frequency resource map;

respectively performing an inverse fast Fourier transform (IFFT) on the DFT-transformed signals mapped on subcarriers corresponding to the same symbol on the time-frequency resource map;

respectively attaching a cyclic prefix to the IFFT-transformed signals mapped on subcarriers corresponding to the same symbol on the time-frequency resource map;  
and

transmitting each symbol having IFFT-transformed signals with an attached cyclic prefix as a single carrier frequency division multiple access (SC-FDMA) symbol.

26. (New) The method of claim 18, further comprising transmitting the signals mapped to the time-frequency resource map through a physical uplink shared channel (PUSCH).

27. (New) A mobile station for transmitting uplink signals comprising control signals and data signals in a wireless communication system, the mobile station comprising:

a processor serially multiplexing first control signals and data signals;

the processor sequentially mapping the multiplexed signals to a time-frequency resource map according to a time-first mapping method, wherein the time-frequency resource map comprises a plurality of symbols and a plurality of subcarriers for each symbol, and a reference signal is mapped to at least one subcarrier corresponding to one of the plurality of symbols; and

the processor mapping ACK/NACK control signals to subcarriers corresponding to symbols near the symbol on which the reference signal is mapped.

28. (New) The mobile station of claim 27, wherein the first control signals comprise at least one of:

precoding matrix index (PMI) signals; or  
channel quality indicator (CQI) signals.

29. (New) The mobile station of claim 27, wherein the ACK/NACK control signals are mapped to the subcarriers by overwriting the first control signals or data signals mapped to the subcarriers corresponding to symbols near the symbol on which the reference signal is mapped.

30. (New) The mobile station of claim 27, wherein the reference signal is mapped to at least one subcarrier corresponding to a fourth symbol out of seven symbols in a slot.

31. (New) The mobile station of claim 27, wherein the ACK/NACK control signals are mapped to subcarriers corresponding to symbols on either side of the symbol on which the reference signal is mapped.

32. (New) The mobile station of claim 27, wherein the ACK/NACK control signals are mapped to subcarriers corresponding to a third symbol and a fifth symbol out of seven symbols in a slot.

33. (New) The mobile station of claim 27, wherein the ACK/NACK control signals are channel coded independently of the data signals or first control signals.

34. (New) The mobile station of claim 27, further comprising:

the processor respectively performing for each of the plurality of symbols having mapped multiplexed signals or mapped ACK/NACK control signals, a discrete Fourier transform (DFT) on signals mapped on subcarriers corresponding to the same symbol on the time-frequency resource map;

the processor respectively performing an inverse fast Fourier transform (IFFT) on the DFT-transformed signals mapped on subcarriers corresponding to the same symbol on the time-frequency resource map;

the processor respectively attaching a cyclic prefix to the IFFT-transformed signals mapped on subcarriers corresponding to the same symbol on the time-frequency resource map; and

the processor transmitting each symbol having IFFT-transformed signals with an attached cyclic prefix as a single carrier frequency division multiple access (SC-FDMA) symbol.

35. (New) The mobile station of claim 27, further comprising the processor transmitting the signals mapped to the time-frequency resource map through a physical uplink shared channel (PUSCH).



36. (New) A mobile station for transmitting uplink signals comprising first control signals, ACK/NACK control signals and data signals in a wireless communication system, the mobile station comprising:

a processor channel coding each of the first control signals, the ACK/NACK control signals, and the data signals, wherein the first control signals, the ACK/NACK control signals and the data signals are independently channel coded from each other;

the processor serially multiplexing the channel coded first control signals and the channel coded data signals;

the processor sequentially mapping the multiplexed signals to a time-frequency resource map according to a time-first mapping method, wherein the time-frequency resource map comprises a plurality of symbols and a plurality of subcarriers for each symbol, and a reference signal is mapped to at least one subcarrier corresponding to one of the plurality of symbols; and

the processor mapping the channel coded ACK/NACK control signals to subcarriers corresponding to symbols near the symbol on which the reference signal is mapped.

37. (New) The mobile station of claim 36, wherein the processor channel codes the data signals by:

attaching a transport block cyclic redundancy check (CRC) to a transport block for transmitting the data signals;

segmenting the transport block having the attached transport block CRC into at least one code block unit;

attaching a code block CRC to the at least one segmented code block;

performing channel coding on the data attached with the code block CRC; and

performing rate matching and code block concatenation one the channel coded data.

38. (New) The mobile station of claim 36, wherein the first control signals comprise at least one of:

precoding matrix index (PMI) signals; or

channel quality indicator (CQI) signals.

39. (New) The mobile station of claim 36, wherein the channel coded ACK/NACK control signals are mapped to the subcarriers by overwriting the channel coded first control signals or channel coded data signals mapped to the subcarriers corresponding to symbols near the symbol on which the reference signal is mapped.

40. (New) The mobile station of claim 36, wherein the reference signal is mapped to at least one subcarrier corresponding to a fourth symbol out of seven symbols in a slot.

41. (New) The mobile station of claim 36, wherein the channel coded ACK/NACK control signals are mapped to subcarriers corresponding to symbols on either side of the symbol on which the reference signal is mapped.

42. (New) The mobile station of claim 36, wherein the ACK/NACK control signals are mapped to subcarriers corresponding to a third symbol and a fifth symbol out of seven symbols in a slot.

43. (New) The mobile station of claim 36, further comprising:

the processor respectively performing for each of the plurality of symbols having mapped multiplexed signals or mapped ACK/NACK control signals, a discrete Fourier transform (DFT) on signals mapped on subcarriers corresponding to the same symbol on the time-frequency resource map;

the processor respectively performing an inverse fast Fourier transform (IFFT) on the DFT-transformed signals mapped on subcarriers corresponding to the same symbol on the time-frequency resource map;

the processor respectively attaching a cyclic prefix to the IFFT-transformed signals mapped on subcarriers corresponding to the same symbol on the time-frequency resource map; and

the processor transmitting each symbol having IFFT-transformed signals with an attached cyclic prefix as a single carrier frequency division multiple access (SC-FDMA) symbol.

44. (New) The mobile station of claim 36, further comprising the processor transmitting the signals mapped to the time-frequency resource map through a physical uplink shared channel (PUSCH).

REMARKS

With this paper, claims 1-8 have been canceled without prejudice and new claims 9-44 have been added. Applicants submit that support for the new claims is found in the specification as originally filed and that no new matter has been added.

Applicants respectfully request prompt examination and allowance by the Examiner. If the Examiner has any questions regarding the subject matter submitted herein, please contact the undersigned attorney at the phone number listed below.

Applicants request that all deficits and credits in regards to this filing be referenced to Deposit Account No. 502290.

Respectfully submitted,

Lee, Hong, Degerman, Kang & Waimey

Date: November 25, 2009

By:           / Harry S. Lee/   
Harry S. Lee  
Registration No. 56,814

Customer No. 035884

## Electronic Patent Application Fee Transmittal

<b>Application Number:</b>	12209136			
<b>Filing Date:</b>	11-Sep-2008			
<b>Title of Invention:</b>	METHOD FOR TRANSMITTING UPLINK SIGNALS			
<b>First Named Inventor/Applicant Name:</b>	Dae Won Lee			
<b>Filer:</b>	Harry Sung Lee/Jane Kim			
<b>Attorney Docket Number:</b>	2101-3573			
Filed as Large Entity				
<b>Utility under 35 USC 111(a) Filing Fees</b>				
<b>Description</b>	<b>Fee Code</b>	<b>Quantity</b>	<b>Amount</b>	<b>Sub-Total in USD(\$)</b>
<b>Basic Filing:</b>				
<b>Pages:</b>				
<b>Claims:</b>				
Claims in excess of 20	1202	16	52	832
Independent claims in excess of 3	1201	1	220	220
<b>Miscellaneous-Filing:</b>				
<b>Petition:</b>				
<b>Patent-Appeals-and-Interference:</b>				
<b>Post-Allowance-and-Post-Issuance:</b>				

Description	Fee Code	Quantity	Amount	Sub-Total in USD(\$)
<b>Extension-of-Time:</b>				
<b>Miscellaneous:</b>				
<b>Total in USD (\$)</b>				<b>1052</b>

## Electronic Acknowledgement Receipt

<b>EFS ID:</b>	6530144
<b>Application Number:</b>	12209136
<b>International Application Number:</b>	
<b>Confirmation Number:</b>	3897
<b>Title of Invention:</b>	METHOD FOR TRANSMITTING UPLINK SIGNALS
<b>First Named Inventor/Applicant Name:</b>	Dae Won Lee
<b>Customer Number:</b>	35884
<b>Filer:</b>	Harry Sung Lee/Jane Kim
<b>Filer Authorized By:</b>	Harry Sung Lee
<b>Attorney Docket Number:</b>	2101-3573
<b>Receipt Date:</b>	25-NOV-2009
<b>Filing Date:</b>	11-SEP-2008
<b>Time Stamp:</b>	18:03:49
<b>Application Type:</b>	Utility under 35 USC 111(a)

### Payment information:

Submitted with Payment	yes
Payment Type	Deposit Account
Payment was successfully received in RAM	\$1052
RAM confirmation Number	3728
Deposit Account	502290
Authorized User	

### File Listing:

Document Number	Document Description	File Name	File Size(Bytes)/ Message Digest	Multi Part /.zip	Pages (if appl.)
-----------------	----------------------	-----------	-------------------------------------	------------------	------------------

1		2101-3573_PreliminaryAmendment.pdf	643662 <small>7dbd59cc8cb943df8d617b4cc032699408362f88</small>	yes	12
<b>Multipart Description/PDF files in .zip description</b>					
<b>Document Description</b>		<b>Start</b>		<b>End</b>	
Miscellaneous Incoming Letter		1		1	
Preliminary Amendment		2		2	
Claims		3		11	
Applicant Arguments/Remarks Made in an Amendment		12		12	
<b>Warnings:</b>					
<b>Information:</b>					
2	Fee Worksheet (PTO-875)	fee-info.pdf	31781 <small>674767ab8991273c5969b4a77f16513e58c431de</small>	no	2
<b>Warnings:</b>					
<b>Information:</b>					
<b>Total Files Size (in bytes):</b>			675443		
<p><b>This Acknowledgement Receipt evidences receipt on the noted date by the USPTO of the indicated documents, characterized by the applicant, and including page counts, where applicable. It serves as evidence of receipt similar to a Post Card, as described in MPEP 503.</b></p> <p><b><u>New Applications Under 35 U.S.C. 111</u></b>  <b>If a new application is being filed and the application includes the necessary components for a filing date (see 37 CFR 1.53(b)-(d) and MPEP 506), a Filing Receipt (37 CFR 1.54) will be issued in due course and the date shown on this Acknowledgement Receipt will establish the filing date of the application.</b></p> <p><b><u>National Stage of an International Application under 35 U.S.C. 371</u></b>  <b>If a timely submission to enter the national stage of an international application is compliant with the conditions of 35 U.S.C. 371 and other applicable requirements a Form PCT/DO/EO/903 indicating acceptance of the application as a national stage submission under 35 U.S.C. 371 will be issued in addition to the Filing Receipt, in due course.</b></p> <p><b><u>New International Application Filed with the USPTO as a Receiving Office</u></b>  <b>If a new international application is being filed and the international application includes the necessary components for an international filing date (see PCT Article 11 and MPEP 1810), a Notification of the International Application Number and of the International Filing Date (Form PCT/RO/105) will be issued in due course, subject to prescriptions concerning national security, and the date shown on this Acknowledgement Receipt will establish the international filing date of the application.</b></p>					



Customer No. 035884

**PATENT**  
Attorney Docket: 2101-3573

In re application of:  
Dae Won LEE et al.  
Serial No: 12/209,136  
Filed: September 11, 2008  
For: METHOD FOR TRANSMITTING UPLINK SIGNALS

Art Unit: 2617  
Examiner: Bost, Dwayne D.  
Confirmation No. 3897

Mail Stop Amendment  
Commissioner for Patents  
P.O. Box 1450  
Alexandria, VA 22313-1450

Sir:  
Transmitted herewith is a Preliminary Amendment in the above-identified application.

- A petition for extension of time for \_\_\_ month(s) is enclosed.
- Terminal Disclaimer(s) is/are enclosed.
- \_\_\_ sheet(s) of replacement drawing(s) is/are enclosed.
- An information disclosure statement in accordance with 37 CFR 1.56 and 1.97 is enclosed.
- No additional fee is required.

The fee has been calculated as shown below:

	(Col. 1) CLAIMS REMAINING AFTER AMENDMENT		(Col. 2) HIGHEST NUMBER PREVIOUSLY PAID FOR		(Col. 3) PRESENT EXTRA*	LG/SM \$ ENTITY FEE		ADD'L FEE DUE
TOTAL CLAIMS FEE	36	-	20	**	16	LG=\$52 SM=\$26	\$52	\$ 832
INDEPENDENT CLAIMS FEE	4	-	3	***	1	LG=\$220 SM=\$110	\$220	\$ 220
FIRST PRESENTATION OF MULTIPLE DEPENDENT CLAIMS						LARGE ENTITY FEE = \$390 SMALL ENTITY FEE = \$195		\$ 0
<b>TOTAL</b>								<b>\$ 1,052</b>

\* If the entry in Col. 1 is less than the entry in Col. 2, write "0" in Col. 3.  
 \*\* If the "Highest Number Previously Paid For" IN THIS SPACE is less than 20, write "20" in this space.  
 \*\*\* If the "Highest Number Previously Paid For" IN THIS SPACE is less than 3, write "3" in this space. The "Highest Number Previously Paid For" (Total or Independent) is the highest number found from the equivalent box on Col. 1 of a prior amendment or the number of claims originally filed.

- A check in the amount of \$ \_\_\_\_\_ to cover the filing fee is enclosed.
- A check in the amount of \$ \_\_\_\_\_ to cover the extension fee is enclosed.
- A check in the amount of \$ \_\_\_\_\_ to cover the information disclosure statement fee is enclosed.
- A check in the amount of \$ \_\_\_\_\_ to cover the petition fee is enclosed.
- The Commissioner is hereby authorized to charge payment of the following fees associated with this communication or credit any overpayment to Deposit Account No. 502290.
  - The amount of \$ 1,052 for the filing fee.
  - The amount of \$ \_\_\_\_\_ for the extension fee.
  - The amount of \$ \_\_\_\_\_ for the terminal disclaimer fee.
  - The amount of \$ \_\_\_\_\_ for the Appeal Brief fee.
  - Any filing fees under 37 CFR 1.16 for the presentation of extra claims.
  - Any patent application processing fees under 37 CFR 1.17.

Respectfully submitted,  
Lee, Hong, Degerman, Kang & Waimey

Date: November 25, 2009

By:           /Harry S. Lee/            
Harry S. Lee  
Registration No. 56,814

Customer #035884

Under the Paperwork Reduction Act of 1995, no persons are required to respond to a collection of information unless it displays a valid OMB control number.

<b>PATENT APPLICATION FEE DETERMINATION RECORD</b> Substitute for Form PTO-875					Application or Docket Number <b>12/209,136</b>		Filing Date <b>09/11/2008</b>		<input type="checkbox"/> To be Mailed				
<b>APPLICATION AS FILED – PART I</b>							<b>OTHER THAN</b>						
(Column 1)			(Column 2)		SMALL ENTITY <input type="checkbox"/>		OR		SMALL ENTITY				
FOR		NUMBER FILED	NUMBER EXTRA		RATE (\$)	FEE (\$)	OR		RATE (\$)	FEE (\$)			
<input type="checkbox"/> BASIC FEE <small>(37 CFR 1.16(a), (b), or (c))</small>		N/A	N/A		N/A				N/A				
<input type="checkbox"/> SEARCH FEE <small>(37 CFR 1.16(k), (l), or (m))</small>		N/A	N/A		N/A				N/A				
<input type="checkbox"/> EXAMINATION FEE <small>(37 CFR 1.16(o), (p), or (q))</small>		N/A	N/A		N/A				N/A				
TOTAL CLAIMS <small>(37 CFR 1.16(i))</small>		minus 20 =	*		X \$ =				X \$ =				
INDEPENDENT CLAIMS <small>(37 CFR 1.16(h))</small>		minus 3 =	*		X \$ =				X \$ =				
<input type="checkbox"/> APPLICATION SIZE FEE <small>(37 CFR 1.16(s))</small>		If the specification and drawings exceed 100 sheets of paper, the application size fee due is \$250 (\$125 for small entity) for each additional 50 sheets or fraction thereof. See 35 U.S.C. 41(a)(1)(G) and 37 CFR 1.16(s).											
<input type="checkbox"/> MULTIPLE DEPENDENT CLAIM PRESENT <small>(37 CFR 1.16(j))</small>													
* If the difference in column 1 is less than zero, enter "0" in column 2.													
<b>APPLICATION AS AMENDED – PART II</b>					<b>OTHER THAN</b>								
(Column 1)			(Column 2)		(Column 3)			SMALL ENTITY		OR		SMALL ENTITY	
<b>AMENDMENT</b>	<b>11/25/2009</b>		CLAIMS REMAINING AFTER AMENDMENT		HIGHEST NUMBER PREVIOUSLY PAID FOR	PRESENT EXTRA	RATE (\$)	ADDITIONAL FEE (\$)		RATE (\$)	ADDITIONAL FEE (\$)		
	<small>Total (37 CFR 1.16(i))</small>		* 36	Minus	** 20	= 16	X \$ =		OR	X \$52=	832		
	<small>Independent (37 CFR 1.16(h))</small>		* 4	Minus	***3	= 1	X \$ =		OR	X \$220=	220		
	<input type="checkbox"/> Application Size Fee <small>(37 CFR 1.16(s))</small>												
	<input type="checkbox"/> FIRST PRESENTATION OF MULTIPLE DEPENDENT CLAIM <small>(37 CFR 1.16(j))</small>												
							TOTAL ADD'L FEE		OR	TOTAL ADD'L FEE	<b>1052</b>		
(Column 1)			(Column 2)		(Column 3)			SMALL ENTITY		OR		SMALL ENTITY	
<b>AMENDMENT</b>			CLAIMS REMAINING AFTER AMENDMENT		HIGHEST NUMBER PREVIOUSLY PAID FOR	PRESENT EXTRA	RATE (\$)	ADDITIONAL FEE (\$)		RATE (\$)	ADDITIONAL FEE (\$)		
	<small>Total (37 CFR 1.16(i))</small>		*	Minus	**	=	X \$ =		OR	X \$ =			
	<small>Independent (37 CFR 1.16(h))</small>		*	Minus	***	=	X \$ =		OR	X \$ =			
	<input type="checkbox"/> Application Size Fee <small>(37 CFR 1.16(s))</small>												
	<input type="checkbox"/> FIRST PRESENTATION OF MULTIPLE DEPENDENT CLAIM <small>(37 CFR 1.16(j))</small>												
							TOTAL ADD'L FEE		OR	TOTAL ADD'L FEE			
<p>* If the entry in column 1 is less than the entry in column 2, write "0" in column 3.</p> <p>** If the "Highest Number Previously Paid For" IN THIS SPACE is less than 20, enter "20".</p> <p>*** If the "Highest Number Previously Paid For" IN THIS SPACE is less than 3, enter "3".</p> <p>The "Highest Number Previously Paid For" (Total or Independent) is the highest number found in the appropriate box in column 1.</p>													
							Legal Instrument Examiner: /SHARAIN MORELAND/						

This collection of information is required by 37 CFR 1.16. The information is required to obtain or retain a benefit by the public which is to file (and by the USPTO to process) an application. Confidentiality is governed by 35 U.S.C. 122 and 37 CFR 1.14. This collection is estimated to take 12 minutes to complete, including gathering, preparing, and submitting the completed application form to the USPTO. Time will vary depending upon the individual case. Any comments on the amount of time you require to complete this form and/or suggestions for reducing this burden, should be sent to the Chief Information Officer, U.S. Patent and Trademark Office, U.S. Department of Commerce, P.O. Box 1450, Alexandria, VA 22313-1450. DO NOT SEND FEES OR COMPLETED FORMS TO THIS ADDRESS. **SEND TO: Commissioner for Patents, P.O. Box 1450, Alexandria, VA 22313-1450.**

If you need assistance in completing the form, call 1-800-PTO-9199 and select option 2.



별첨 사본은 아래 출원의 원본과 동일함을 증명함.

This is to certify that the following application annexed hereto is a true copy from the records of the Korean Intellectual Property Office.

출원 번호 : 10-2008-0068634  
Application Number

출원 년 월 일 : 2008년 07월 15일  
Filing Date JUL 15, 2008

출원 인 : 엘지전자 주식회사  
Applicant(s) LG Electronics Inc.

2008년 10월 21일

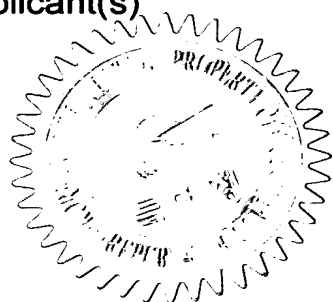

특 허 청

COMMISSIONER



◆ This certificate was issued by Korean Intellectual Property Office. Please confirm any forgery or alteration of the contents by an issue number or a barcode of the document below through the KIPOnet- Online Issue of the Certificates' menu of Korean Intellectual Property Office homepage (www.kipo.go.kr). But please notice that the confirmation by the issue number is available only for 90 days.

제출 일자 : 2008-07-15

1020080068634

**【서지사항】**

**【서류명】** 특허출원서  
**【참조번호】** 0002  
**【출원구분】** 특허출원  
**【출원인】**  
**【명칭】** 엘지전자 주식회사  
**【출원인코드】** 1-2002-012840-3  
**【대리인】**  
**【성명】** 김용인  
**【대리인코드】** 9-1998-000022-1  
**【포괄위임등록번호】** 2007-001879-5  
**【대리인】**  
**【성명】** 박영복  
**【대리인코드】** 9-2006-001451-3  
**【포괄위임등록번호】** 2007-001886-1  
**【발명의 국문명칭】** 상향링크 신호 전송 방법  
**【발명의 영문명칭】** Method For Transmitting Uplink Signals  
**【발명자】**  
**【성명】** 이대원  
**【성명의 영문표기】** LEE,Dae Won  
**【주민등록번호】** 801122-1XXXXXX  
**【우편번호】** 431-080  
**【주소】** 경기 안양시 동안구 호계동 533번지 LG 제1연구단지  
**【국적】** KR  
**【발명자】**  
**【성명】** 김봉희

제출 일자 : 2008-07-15 1020080068634

**【성명의 영문표기】** KIM, Bong Hoe  
**【주민등록번호】** 700227-1XXXXXX  
**【우편번호】** 431-080  
**【주소】** 경기 안양시 동안구 호계동 533번지 LG 제1연구단지  
**【국적】** KR  
**【발명자】**  
**【성명】** 윤영우  
**【성명의 영문표기】** YUN, Young Woo  
**【주민등록번호】** 700122-1XXXXXX  
**【우편번호】** 431-080  
**【주소】** 경기 안양시 동안구 호계동 533번지 LG 제1연구단지  
**【국적】** KR  
**【발명자】**  
**【성명】** 김기준  
**【성명의 영문표기】** KIM, Ki Jun  
**【주민등록번호】** 680704-1XXXXXX  
**【우편번호】** 431-080  
**【주소】** 경기 안양시 동안구 호계동 533번지 LG 제1연구단지  
**【국적】** KR  
**【발명자】**  
**【성명】** 노동욱  
**【성명의 영문표기】** ROH, Dong Wook  
**【주민등록번호】** 730829-1XXXXXX  
**【우편번호】** 431-080  
**【주소】** 경기 안양시 동안구 호계동 533번지 LG 제1연구단지  
**【국적】** KR

제출 일자 : 2008-07-15

1020080068634

**【발명자】**

**【성명】** 김학성  
**【성명의 영문표기】** KIM, Hak Seong  
**【주민등록번호】** 710307-1XXXXXX  
**【우편번호】** 431-080  
**【주소】** 경기 안양시 동안구 호계동 533번지 LG 제1연구단지  
**【국적】** KR

**【발명자】**

**【성명】** 박현욱  
**【성명의 영문표기】** PARK, Hyun Wook  
**【주민등록번호】** 740512-1XXXXXX  
**【우편번호】** 431-080  
**【주소】** 경기 안양시 동안구 호계동 533번지 LG 제1연구단지  
**【국적】** KR

**【우선권 주장】**

**【출원국명】** US  
**【출원번호】** 60/972,244  
**【출원일자】** 2007.09.13  
**【증명서류】** 미첨부

**【우선권 주장】**

**【출원국명】** US  
**【출원번호】** 60/987,427  
**【출원일자】** 2007.11.13  
**【증명서류】** 미첨부

**【우선권 주장】**

**【출원국명】** US

제출 일자 : 2008-07-15

1020080068634

【출원번호】 60/988,433

【출원일자】 2007.11.16

【증명서류】 미첨부

위와 같이 특허청장에게 제출합니다.

대리인

김용인 (인)

대리인

박영복 (인)

## 【수수료】

【출원료】	0 면	38,000 원
【가산출원료】	30 면	0 원
【우선권주장료】	3 건	60,000 원
【심사청구료】	0 항	0 원
【합계】	98,000 원	

**【요약서】****【요약】**

ACK/NACK 신호, ACK/NACK 신호를 제외한 제어 신호 및 데이터 신호를 포함한 상향링크 신호를 전송하는 방법이 개시된다. 즉, 제어 신호와 데이터 신호를 직렬적으로 다중화하고, 이와 같이 다중화된 신호를 복수의 심볼들 및 복수의 가상 부반송파들(virtual subcarriers)로 구성되는 특정 자원 영역 내에서 시간 축 방향을 우선적으로 하여 순차적으로 매핑한 후, ACK/NACK 신호를 상술한 복수의 심볼 중 참조 신호(reference signal)가 전송되는 심볼(Symbol)에 인접하는 양 심볼에 배치함으로써 우선순위가 높은 신호의 수신 신뢰도가 높아지도록 상향링크 신호를 전송할 수 있다.

**【대표도】**

도 6

**【색인어】**

ACK/NACK, Reference Signal, PUSCH



**【명세서】****【발명의 명칭】**

상향링크 신호 전송 방법 {Method For Transmitting Uplink Signals}

**【발명의 상세한 설명】****【기술분야】**

<1> 본 발명은 이동통신 기술에 대한 것으로서, 구체적으로 ACK/NACK 신호, ACK/NACK 신호를 제외한 제어 신호 및 데이터 신호를 포함한 상향링크 신호를 전송하는 기술에 대한 것이다.

**【배경기술】**

<2> 이동통신 시스템의 사용자 기기(UE)는 상향링크를 통해 다양한 신호를 전송한다. UE가 전송하는 상향링크 신호로 크게 데이터와 제어 신호로 구분될 수 있다. 또한, 상향링크로 전송되는 제어 신호에는 HARQ 통신을 위한 상향링크 ACK/NACK 신호, 채널품질 지시자(CQI) 정보, PMI (Precoding Matrix Index) 등이 있다.

<3> 3GPP LTE 시스템에서는 상향링크 신호 전송을 위해 SC-FDMA 방식을 이용하고 있다. 또한, 3GPP LTE 방식에서는 일반적으로 상술한 상향링크 신호 중 데이터 신호와 제어 신호가 먼저 다중화되며, 하향링크 데이터에 대한 상향링크 ACK/NACK 신호 전송이 요구되는 경우 상술한 바와 같이 다중화된 신호에 ACK/NACK 신호가 데이터 또는 제어 신호를 평치링하여 전송되는 것으로 규정하고 있다. 이하에서는 ACK/NACK 신호와 ACK/NACK 이외의 다른 제어 신호를 편리하게 구분지어 설명하기

제출 일자 : 2008-07-15 1020080068634

위해 "제어 신호"는 상기 ACK/NACK 신호를 제외한 제어 신호만을 지칭하고, ACK/NACK 신호는 별도로 "ACK/NACK 신호"로서 지칭하는 것을 가정한다.

<4> 한편, 3GPP LTE에 대한 아테네 회의(#50)에서는 제어 정보가 데이터와 함께 다중화되어 전송되는 경우, 데이터 정보는 제어 정보와 함께 레이트 매칭(Rate Matching)되고, 모든 제어 정보는 참조 신호(Reference Signal)에 근접하여 전송하는 것으로 결정되었다. 이는 일반적으로 데이터에 비해 제어 신호에 높은 신뢰도(Reliability)가 요구되기 때문에, 제어 신호를 참조 신호에 근접하여 전송함으로써 채널 추정 성능을 향상시키기 위함이다.

<5> 다만, 상향링크로 전송되는 제어 신호에는 상술한 바와 같이 다양한 신호가 존재하며, ACK/NACK 신호의 경우 다른 제어 신호에 비해 더 높은 신뢰도가 요구된다. 따라서, 모든 제어 신호를 참조 신호에 근접하여 전송하면서 상향링크 ACK/NACK 신호 전송이 필요한 경우, ACK/NACK 신호를 참조 신호 부근에 배치된 제어 신호를 평처링하여 전송하거나, 또는 ACK/NACK 신호를 참조 신호 부근에 전송할 수 없는 문제가 발생할 수 있다.

<6> 따라서, 상향링크 신호 전송에 있어 ACK/NACK 신호와 기타 제어 정보간에 우선순위를 고려하여 이들을 자원 영역에 효율적으로 배치하여 전송하는 기술이 요구되고 있다.

#### 【발명의 내용】

**【해결하고자 하는 과제】**

<7> 상술한 바와 같은 문제를 해결하기 위한 본 발명의 일 실시형태에서는 상향 링크 신호 전송에 있어 ACK/NACK 신호와 기타 제어 정보간에 우선순위를 고려하여 이들을 자원 영역에 효율적으로 배치하여 전송하는 방법을 제공하고자 한다.

<8> 또한, 상술한 바와 같은 신호 배치를 이용하여 상향링크 신호를 전송하는 방법을 제공하고자 한다.

**【과제 해결 수단】**

<9> 상술한 바와 같은 과제를 해결하기 위해 본 발명의 일 실시형태에서는 ACK/NACK 신호, 상기 ACK/NACK 신호를 제외한 제어 신호 및 데이터 신호를 포함한 상향링크 신호를 전송하는 방법을 제공한다. 본 방법은 상기 제어 신호 및 상기 데이터 신호를 직렬적으로 다중화하는 단계; 상기 다중화된 신호를 복수의 심볼들 및 복수의 가상 부반송파들(virtual subcarriers)로 구성되는 특정 자원 영역 내에서 시간 축 방향을 우선적으로 하여 순차적으로 매핑하는 단계; 및 상기 ACK/NACK 신호를 상기 복수의 심볼 중 참조 신호(reference signal)가 전송되는 심볼(Symbol)에 인접하는 양 심볼에 배치하는 단계를 포함한다.

<10> 이때, 상기 ACK/NACK 신호는 상기 다중화된 신호의 일부에 겹쳐 쓰여질 수 있다.

<11> 또한, 상기 방법은 상기 특정 자원 영역에 매핑된 신호를 상기 복수의 심볼 각각을 단위로 상기 복수의 가상 부반송파의 인덱스에 따라 DFT(Discrete Furrier

제출 일자 : 2008-07-15 1020080068634

Transform)를 수행하는 단계; 상기 DFT된 심볼 단위 신호에 IFFT(Inverse Fast Furrier Transform)를 수행하고, 순환전치부(CP)를 부착하는 단계; 및 상기 CP가 부착된 심볼 단위 신호를 각각 SC-FDMA 심볼로서 전송하는 단계를 더 포함할 수 있다.

<12> 아울러, 상기 특정 자원 영역에 매핑된 신호를 물리 상향링크 공유 채널(PUSCH)을 통해 전송하는 단계를 더 포함할 수 있다.

<13> 상술한 바와 같은 과제를 해결하기 위해 본 발명의 일 실시형태에서는 ACK/NACK 신호, 상기 ACK/NACK 신호를 제외한 제어 신호 및 데이터 신호를 포함한 상향링크 신호를 전송하는 방법을 제공한다. 본 방법은 상기 데이터, 상기 제어 신호 및 상기 ACK/NACK 신호에 각각 채널 코딩을 수행하는 단계; 각각 채널 코딩된 상기 데이터 및 상기 제어 신호를 직렬적으로 다중화하는 단계; 상기 다중화된 신호를 복수의 심볼들 및 복수의 가상 부반송파들(virtual subcarriers)로 구성되는 특정 자원 영역 내에서 시간 축 방향을 우선적으로 하여 순차적으로 매핑하는 단계; 및 상기 ACK/NACK 신호를 상기 복수의 심볼 중 참조 신호(reference signal)가 전송되는 심볼(Symbol)에 인접하는 양 심볼에 배치하는 단계를 포함한다.

<14> 이때, 상기 데이터 신호에 채널 코딩을 수행하는 단계는, 상기 데이터 신호 전송을 위한 전송 블록에 전송 블록용 CRC를 부착하는 단계; 상기 전송 블록용 CRC가 부착된 전송 블록을 코드 블록 단위로 분할하고, 분할된 상기 코드 블록에 코드블록용 CRC를 부착하는 단계; 상기 코드블록용 CRC가 부착된 데이터에 채널 코딩을 수행하는 단계; 상기 채널 코딩된 데이터에 레이트 매칭 및 코드 블록 연결을

수행하는 단계를 포함할 수 있다.

**【효과】**

<15> 상술한 바와 같은 본 발명의 실시형태들에서는 상향링크 신호 전송에 있어 ACK/NACK 신호와 기타 제어 정보간에 우선순위에 따라 자원 영역에 효율적으로 배치하여 전송할 수 있다.

<16> 또한, 우선순위가 높은 ACK/NACK 신호가 채널 추정 효과를 더 획득하도록 설정할 수 있다.

**【발명의 실시를 위한 구체적인 내용】**

<17> 이하, 본 발명에 따른 바람직한 실시 형태를 첨부된 도면을 참조하여 상세하게 설명한다. 첨부된 도면과 함께 이하에 개시될 상세한 설명은 본 발명의 예시적인 실시형태를 설명하고자 하는 것이며, 본 발명이 실시될 수 있는 유일한 실시형태를 나타내고자 하는 것이 아니다. 이하의 상세한 설명은 본 발명의 완전한 이해를 제공하기 위해서 구체적 세부사항을 포함한다. 그러나, 당업자는 본 발명이 이러한 구체적 세부사항 없이도 실시될 수 있음을 안다.

<18> 한편, 몇몇 경우, 본 발명의 개념이 모호해지는 것을 피하기 위하여 공지의 구조 및 장치는 생략되거나, 각 구조 및 장치의 핵심기능을 중심으로 한 블록도 형식으로 도시된다. 또한, 본 명세서 전체에서 동일한 구성요소에 대해서는 동일한 도면 부호를 사용하여 설명한다.

<19> 상술한 바와 같이 본 발명의 일 실시형태에서는 상향링크 신호 전송에 있어

제출 일자 : 2008-07-15 1020080068634

ACK/NACK 신호와 기타 제어 정보간에 우선순위를 고려하여 이들을 자원 영역에 효율적으로 배치하여 전송하는 방법을 제공한다. 이를 위해 먼저 3GPP LTE 시스템의 예를 들어 상향링크 신호 전송을 위한 구체적인 방법에 대해 살펴본다.

<20> 도 1은 SC-FDMA 방식으로 신호를 전송하는 방법을 설명하기 위한 송신단의 블록도이다.

<21> 3GPP LTE 시스템에서는 상술한 바와 같이 SC-FDMA(Single Carrier Frequency Division Multiplexing Access) 방식에 따라 상향링크 신호를 전송한다. 구체적으로 먼저 전송할 정보 시퀀스(information sequence)에 DFT(Discrete Fourier Transform)하기 위하여 직-병렬 변환을 수행한다(101). 이와 같이 병렬 시퀀스로 변환된 신호에 DFT가 수행되며(102), 그 후 단일 반송파 특성을 가지도록 IFFT(Inverse Fast Furrier Transform)을 수행할 수 있다(103). 이때 IFFT 모듈(103)에 삽입되는 정보의 길이는 IFFT 모듈(103)의 크기와 똑같지 않을 수도 있으나, DFT 모듈(102)에 의해 DFT된 결과가 연속된 IFFT 입력 인덱스를 가지고 매핑되는 것이 요구된다.

<22> IFFT를 취해진 값들은 다시 병-직렬 변환 모듈(104)에 의해 직렬 신호로 변환된다. 그 후, 순환전치부(Cyclic Prefix; 이하 "CP")가 더해져 OFDM 심볼의 구조 형태로 변경되어(105), 실제 시공간으로 통하여 전송된다.

<23> 상술한 바와 같은 SC-FDMA 방식에 따르면, 단일 반송파 성질을 유지하면서도, 낮은 PAPR(Peak Power-to-Average Power Ratio) 및/또는 CM(Cubic Metric)을 가지는 장점이 있다. 다만, 이와 같이 단일 반송파 성질을 유지하면서,

제출 일자 : 2008-07-15 1020080068634

낮은 PAPR/CM 조건을 충족시키기 위해서는 OFDM 형식으로 IFFT 모듈(103)에 DFT 프리코딩( precoding)된 정보를 입력할 때, 정보를 연속된 인덱스에 매핑하여 입력하는 것이 요구된다. 즉 OFDM의 연속된 부반송파에 DFT 프리코딩된 정보를 삽입하는 것이 요구된다. 그러므로 상향링크로 정보를 전송할 때에는 서로 다른 성격을 가진 정보 (예를 들어, 제어정보와 데이터 정보)라도 같이 다중화(Multiplexing)되어 한꺼번에 DFT 프리코딩을 거쳐 OFDM 방식으로 전송되는 것이 바람직하다.

- <24>            이하 데이터와 제어 정보의 다중화 과정에 대해 설명한다.
- <25>            도 2는 상향링크 신호 전송을 위해 데이터, 제어 정보 및 ACK/NACK 신호의 다중화 과정을 설명하기 위한 도면이다.
- <26>            제어정보와 다중화되는 데이터 정보는 상향링크로 전송해야하는 전송 블록(Transport Block; 이하 "TB")에 TB용 CRC를 부착한 후 (S201), TB 크기에 따라 여러 개의 코드 블록(Code block; 이하 "CB")으로 나뉘어지게 된다 (S202). 그 후, 여러개의 CB들에는 CB용 CRC가 부착되며(S203), 이 결과값에 채널 코딩이 수행되게 된다 (S204). 아울러, 채널 코딩된 데이터들은 레이트 매칭(S205)을 거친 후, 다시 CB들 간의 결합이 수행되며(S206), 이와 같이 연결된 CB들은 이후 제어 정보와 다중화되게 된다(S230). 한편, 상술한 바와 같은 과정은 전체적으로 데이터 전송 블록에 대한 채널 코딩 체인에 따른 것으로 볼 수 있다.
- <27>            한편, 제어 정보의 경우 데이터와 별도로 채널 코딩이 수행될 수 있다 (S211). 이와 같이 채널 코딩된 제어 정보는 이후 데이터 및 제어 채널 레이트 매핑 다중화기에 의해 데이터 및 제어 정보 다중화가 수행될 수 있다(S230).

제출 일자 : 2008-07-15 1020080068634

- <28> 한편, ACK/NACK 신호의 경우 데이터 및 제어 신호와 별도로 채널 코딩이 수행되며(S221), 데이터 및 제어 신호 다중화가 이루어진(S230) 상향링크 신호 중 일부에 대한 펄스폭 등의 처리를 통해 상향링크로 전송될 수 있다(S240).
- <29> 상술한 바와 같이 상향링크에서 데이터와 함께 전송가능한 제어정보는 2가지로 분류된다. 하향링크 데이터에 대한 확인 신호인 상향링크(UL) ACK/NACK 신호와 그의 제어정보로 구분이 될 수 있다. 하향링크 데이터에 대한 ACK/NACK 신호는 하향링크 데이터가 존재할 때에만 전송되며, 하향링크 데이터를 받아야 하는지 모르는 단말기는 자신이 UL ACK/NACK 신호를 전송해야함에도 불구하고 모르는 경우가 발생할 수 있기 때문에, 상술한 두 가지 제어정보를 구분하여 데이터와 함께 상향링크로 전송하게 된다. 따라서, 이하의 설명에서는 ACK/NACK 신호와 ACK/NACK 이외에 별도로 전송되는 임의의 다른 제어 신호를 편리하게 구분지어 설명하기 위해 "제어 신호"는 상기 ACK/NACK 신호를 제외한 임의의 제어 신호만을 지칭하고, ACK/NACK 신호는 별도로 "ACK/NACK 신호"로서 지칭하는 것을 가정한다. 좀더 구체적인 실시형태에서 상술한 제어 신호는 ACK/NACK뿐만 아니라 랭크 지시자(Rank Indication)까지 제외된 제어 신호일 수도 있다. 즉, 특정 실시형태에서 제어 신호는 CQI 및 PMI를 나타낼 수 있다. 다만, 이하의 설명은 상술한 제어 신호, 데이터 및 ACK/NACK 신호간의 효율적인 배치에 대한 것인바, 설명의 편의를 위해 제어 신호는 ACK/NACK과 다른 임의의 제어 신호인한 구체적인 형태를 제안하지 않기로 한다.
- <30> 데이터 정보가 상향링크로 전송될 때, 데이터 정보는 제어정보와 함께 전송될 수 있으며, 데이터정보 및 제어정보와 함께 ACK/NACK 정보가 같이 전송될 수 있



제출 일자 : 2008-07-15 1020080068634

다. 또한 데이터 정보와 ACK/NACK 정보만이 같이 상향링크로 전송될 수도 있다.

<31> 데이터 정보가 제어정보 혹은 ACK/NACK 정보와 다중화되어 전송되기 위하여 만들어진 전송 정보 시퀀스는 SC-FDMA 방식으로 전송될 수 있다. 이때 전송정보 시퀀스는 시간 축 우선 매핑(time-first mapping) 방법에 의하여 자원 영역에 매핑되어 전송될 수 있다.

<32> 예를 들면, 전송되는 정보 시퀀스가 1개의 자원 블록(Resource Block) 즉, 12개의 OFDM 부반송파를 사용하여 전송된다고 가정하고, 정보는 한 서브프레임을 통하여 전송된다고 가정하자. 또한, 한 서브프레임은 14개의 SC-FDMA 심볼로 구성되어 있고, 이들 중 2개의 SC-FDMA 심볼을 파일럿 신호인 참조 신호(reference signal)로 사용하는 것을 가정한다. 이때 상향링크로 전송할 수 있는 정보의 변조 심볼의 수는  $12 \times 12 = 144$ 개가 된다.

<33> 144개의 정보 시퀀스 심볼이 12개의 가상 부반송파(virtual subcarrier)와 12개의 SC-FDMA 심볼을 통하여 전송될 수 있다. 이것을 12 곱하기 12의 행렬구조로 나타낸 것을 시간-주파수 매핑(Time-Frequency Mapper)라 부르고, 상향링크로 전송되어야 하는 정보 시퀀스는 SC-FDMA 심볼 축으로 먼저 한 개씩 매핑되어 진다. SC-FDMA 심볼은 시간상으로 구분이 되어 있기 때문에 이를 시간 축 우선 매핑(Time-First Mapping)이라 부른다.

<34> 도 3은 본 발명의 일 실시형태에 따라 정보 시퀀스를 시간 축 우선 매핑 방식에 따라 매핑하는 예를 설명하는 도면이고, 도 4 및 도 5는 도 3에 도시된 바와 같이 시간 축 우선 매핑 방식에 따라 매핑된 정보를 SC-FDMA 방식으로 전송하는 방

법을 설명하는 도면들이다.

- <35>           상향링크로 전송되어야 하는 정보 시퀀스는 시간 주파수 매핑에서 시간 축으로 먼저 시퀀스를 도 3과 같이 나열할 수 있다. 즉, 12개의 정보가 첫번째 가상 부반송파 영역에서 시간 축 방향으로 매핑되고, 다음으로 두번째 가상 부반송파 영역에서 후속하는 12개의 정보가 시간 축 방향으로 매핑되게 된다.
- <36>           이렇게 시간 축으로 먼저 나열하는 방법으로 시간-주파수 매핑이 일어난 후, 도 4 및 도 5에 도시된 바와 같이 주파수축으로 나열된 시퀀스에 DFT 과정을 거치고, 원하는 주파수 대역에 삽입되게 된다. 그 후, 각 주파수 영역 정보에는 IFFT 및 순환전치부(CP) 삽입이 이루어져, 각 주파수 영역 정보는 SC-FDMA 심볼로서 전송될 수 있다. 도 4 및 도 5는 이와 같이 SC-FDMA 심볼을 생성하여 전송하는 과정을 도시하고 있으며, 도 4는 일반 CP(normal CP)를 이용하는 경우를, 도 5는 확장형 CP(extended CP)를 이용하는 경우를 도시하고 있다.
- <37>           상향링크에서는 데이터가 전송될 때 제어정보 또한 동시에 전송될 수 있다. 이 때 제어정보와 데이터 정보는 레이트 매칭(rate matching)을 통해 다중화된다. 그러나 ACK/NACK 정보는 데이터와 제어 정보가 다중화된 심볼 또는 단순히 데이터 정보의 비트 스트림에 겹쳐 쓰여져(over write) 전송될 수 있다. 여기서 "겹쳐 쓰여진다"는 용어의 의미는 자원 영역에 매핑된 특정 정보를 빼고, 그 해당 영역을 대체하여 매핑되는 것을 의미하며, 이를 통해 특정 정보를 삽입하면서도 삽입 후 전체 정보 길이를 동일하게 유지시키는 것을 의미한다. 이러한 과정은 펄처링 등으로 표현될 수도 있다.

제출 일자 : 2008-07-15 1020080068634

- <38> 일반적으로 제어정보는 데이터보다 신뢰도가 높아야 하며, 그렇기 위해서는 참조 신호(reference signal) 근방에 다중화 또는 삽입되어야 채널 추정 성능(channel estimation performance)의 효과를 얻어 성능 향상을 기대할 수 있다.
- <39> 다만, 제어 정보 이외에 ACK/NACK 정보 역시 수신단에서 높은 신뢰도가 요구되는바, 일반 제어 정보를 모두 참조 신호 부근에 배치하는 경우 ACK/NACK 신호와의 우선순위가 고려되어야 한다.
- <40> 따라서, 이하의 설명에서는 데이터 정보 비트 스트림과 제어정보 비트 스트림 그리고 ACK/NACK 정보 시퀀스의 다중화 시, 각 정보들에게 대해서 서로 다른 우선순위를 두고 다중화하는 방법들을 본 발명의 다양한 실시형태로서 설명한다.
- <41> 본 발명의 일 실시형태에서는 제어 정보를 데이터 정보와 직렬적으로 다중화하여, 상술한 바와 같은 시간 축 우선 매핑 방식에 따라 다중 영역에 매핑하는 방법을 제안한다. 여기서, 제어 정보와 데이터 정보를 "직렬적으로 다중화"한다는 의미는 다중화 결과에 대응하는 시퀀스에 제어 정보를 매핑한 후 연이어 데이터를 매핑하는 방식 또는 그 역순의 매핑 방식을 의미하는 것으로 가정한다. 또한, ACK/NACK 신호는 파일럿인 참조 신호가 전송되는 심볼에 인접하는 양 심볼을 통해 전송되도록 배치하는 것을 제안한다.
- <42> 도 6은 본 발명의 일 실시형태에 따라 상향링크 신호를 전송하는 방법을 설명하기 위한 도면이다.

제출 일자 : 2008-07-15 1020080068634

<43> 본 실시형태에서는 제어정보와 데이터 정보가 다중화될 때 직렬적으로 연결되어, 시간 축 우선 매핑 방식에 의해 SC-FDMA 심볼들에 매핑되어 상향링크로 전송되는 것을 제안한다. 만약에 ACK/NACK 정보 또한 전송되어야 한다면, 직렬적으로 다중화된 데이터 중에서 참조 신호 부근에 위치한 변조 심볼을 ping-pong하여 ACK/NACK 신호를 삽입하는 것을 제안한다. 도 6에서 도면부호 601은 ACK/NACK 신호가 전송되지 않는 경우 데이터 및 제어 신호가 직렬적으로 다중화된 형태를 도시한 것이며, 도면부호 602는 상향링크로 ACK/NACK 신호가 전송되어야 하는 경우, ACK/NACK 신호가 다중화된 데이터를 ping-pong하고 배치되는 형태를 도시한 도면이다. 또한, 도면부호 603은 도면부호 602와 같은 정보 시퀀스가 시간 축 우선 매핑 방식에 따라 시간-주파수 영역에 매핑된 형태를 도시하고 있다. 도 6의 도면부호 603에서 참조 신호는 심볼 인덱스 #3과 #4 사이 및 심볼 인덱스 #9와 #10 사이를 통해 전송되는 것을 가정한다.

<44> 도 6의 도면부호 603에 도시된 매핑 형태를 통해 알 수 있는 바와 같이 제어 신호와 데이터는 직렬적으로 연결되어 다중화된 후, 시간 축 우선 매핑 방식에 따라 시간-주파수 영역에서 매핑되며, ACK/NACK 신호는 참조 신호가 전송되는 SC-FDMA 심볼 양 옆의 2개 심볼(도 6에서는 심볼 #3, 4, 9 및 10)에 다중화된 데이터 신호에 겹쳐 쓰여져 전송되도록 설정할 수 있다.

<45> 도 7 및 도 8은 본 발명의 일 실시형태에 따라 ACK/NACK 정보를 전송할 경우 중 전송되어야 할 ACK/NACK 정보의 수가 많은 경우의 처리 방법을 설명하기 위한 도면이다.

제출 일자 : 2008-07-15 1020080068634

- <46> 구체적으로, 전송될 ACK/NACK 정보의 수가 참조 신호 앞뒤로 데이터가 전송되는 (가상 주파수 영역의) 부반송파 개수보다 많을 때, ACK/NACK 정보는 참조 신호에 가장 인접한 양 심볼들 이외에 추가적인 SC-FDMA 심볼을 통해 전송될 수도 있다. 도 7 및 도 8에서는 참조 심볼에 인접한 양 심볼 이외에 참조 심볼에 인접한 순으로 추가적인 심볼을 통해 ACK/NACK을 전송하는 경우를 도시하고 있다.
- <47> 이때 도 8에 도시된 바와 같이 상향링크의 SC-FDMA 서브프레임의 구조에 따라 참조 신호를 중심으로 존재하는 SC-FDMA 심볼의 숫자가 대칭적으로 구성되지 않을 수 있다. 때문에, ACK/NACK 정보를 평처링하여 삽입할 때 이를 고려하여 삽입해야한다.
- <48> 본 발명의 상술한 실시형태에 따라 제어정보가 시간 축 상에서 나열된다고 할 때, 제어 정보는 데이터 정보와 순차적으로 나열하여 자원 영역에 매핑될 수 있다. 또한, ACK/NACK 정보가 참조 신호 근처에 배치된다고 할 경우, ACK/NACK 정보가 덮어쓰는 정보로는 데이터 정보뿐만 아니라 제어 정보도 가능하다.
- <49> 도 9는 본 발명의 또 다른 일 실시형태에 따라 ACK/NACK 신호가 데이터뿐만 아니라 제어 신호를 평처링하여 삽입되는 형태를 도시한 도면이다.
- <50> 실질적으로 ACK/NACK 정보 또한 제어정보이기 때문에, 본 실시형태에서는 제어정보 채널들 중에서 서로 간에 우선 순위를 주어, 높은 우선순위를 가지고 있는 제어정보 채널이 채널 추정 및 보호를 더욱 잘 받기 위하여 참조 신호 근처에 배치

제출 일자 : 2008-07-15 1020080068634

되고, 우선순위가 비교적 낮은 제어정보 채널은 시간상에 순차적으로 매핑하여 전송되는 것을 제안한다. 특히, 본 실시형태에서는 제어정보와 ACK/NACK 정보 중에서 ACK/NACK 정보가 제어정보보다 우선순위가 높은 것으로 가정한다. 이때 제어정보는 데이터와 같이 시간 축 우선 매핑 방식에 의하여 시간상에 순차적으로 나열되어 데이터와 다중화되고, ACK/NACK 정보는 참조 신호 근처에 위치하는 데이터/제어정보를 평처리하여 삽입하는 것을 제안한다.

<51> 구체적으로, 도 9의 도면부호 901은 ACK/NACK 신호를 전송할 필요가 없는 경우, 데이터와 제어 신호를 다중화한 형태를 나타내고 있으며, 도 9의 도면부호 902는 ACK/NACK 신호를 전송해야 하는 경우, 데이터, 제어 신호 및 ACK/NACK 신호의 다중화된 형태를 도시한 도면이다. 아울러, 도 9의 도면부호 903은 도면부호 902에 나타낸 바와 같이 다중화된 상향링크 신호를 시간-주파수 영역에 매핑하여 전송하는 형태를 도시하고 있다.

<52> 도 9의 도면부호 903에서 보는 바와 같이 본 실시형태에서는 ACK/NACK이 참조 신호 부근에 매치된 데이터뿐만 아니라 제어 신호까지 평처리하여 삽입될 수 있음을 알 수 있다. 이렇게 제어정보들 사이에 우선순위를 두어 자원 매핑을 하면, ACK/NACK 정보는 참조 신호 근처에 있기 때문에 좋은 채널 추정 효과를 볼 수 있다. 반면, ACK/NACK 정보에 의하여 평처리되어 없어지는 제어 정보의 수는 작기 때문에 성능저하에 큰 영향을 미치지 않을 수 있다. 또한 제어정보와 데이터 정보의 다중화가 간단하게 연속적으로 이어서 전송되는 구조로 될 수 있기 때문에 다중화 블록(Multiplexing Block)을 간단하게 구현할 수 있는 특징이 있다.

- <53> 이하에서는 상술한 바와 같은 본 발명의 실시형태들에 따라 상향링크 신호를 전송하는 전반적인 절차에 대해 설명한다. 설명의 편의를 위해 상술한 도 2를 참조하여 설명한다.
- <54> 본 발명의 각 실시형태에 따라 상향링크 신호를 전송하기 위해 송신측은 데이터, 제어 신호 및 ACK/NACK 신호에 각각 채널 코딩을 수행한다. 각 상향링크 신호에 대한 채널 코딩은 도 2에 도시된 바와 같이 독립적으로 수행될 수 있다.
- <55> 이때, 데이터 신호에 채널 코딩을 수행하는 과정은 도 2에 도시된 바와 같이 데이터 신호 전송을 위한 TB에 TB용 CRC를 부착하는 과정(S201), TB용 CRC가 부착된 TB를 CB 단위로 분할하고(S202), 분할된 CB들에 CB용 CRC를 부착하는 과정(S203), CB용 CRC가 부착된 데이터에 채널 코딩을 수행하는 과정(S204), 및 채널 코딩된 데이터에 레이트 매칭(S206) 및 CB 연결(S207)을 수행하는 과정을 포함할 수 있다.
- <56> 본 발명의 일 실시형태에서는 이와 같이 각각 채널 코딩된 데이터와 제어 신호를 직렬적으로 다중화하는 것을 제안한다. 직렬적 다중화는 순차적인 인덱스에 데이터를 매핑한 후, 연이어 제어 신호를 매핑하거나, 그 반대의 순서로 매핑하는 것을 의미한다. 한편, 이와 같이 다중화된 신호는 복수의 심볼들(예를 들어, 12개의 SC-FDMA 심볼) 및 복수의 가상 부반송파들(virtual subcarriers)로 구성되는 특정 자원 영역 내에서 시간 축 방향을 우선적으로 하여 순차적으로 매핑할 수 있다.

제출 일자 : 2008-07-15 1020080068634

<57> 아울러, 본 실시형태에서 ACK/NACK 신호는 상기 복수의 심볼 중 참조 신호가 전송되는 심볼에 인접하는 심볼들에 배치하는 것이 바람직하다.

<58> 상술한 바와 같이 개시된 본 발명의 바람직한 실시형태에 대한 상세한 설명은 당업자가 본 발명을 구현하고 실시할 수 있도록 제공되었다. 상기에서는 본 발명의 바람직한 실시 형태를 참조하여 설명하였지만, 해당 기술 분야의 숙련된 당업자는 하기의 특허 청구의 범위에 기재된 본 발명의 사상 및 영역으로부터 벗어나지 않는 범위 내에서 본 발명을 다양하게 수정 및 변경시킬 수 있음을 이해할 수 있을 것이다.

<59> 따라서, 본 발명은 여기에 나타난 실시형태들에 제한되려는 것이 아니라, 여기서 개시된 원리들 및 신규한 특징들과 일치하는 최광의 범위를 부여하려는 것이다.

#### 【산업상이용가능성】

<60> 상술한 실시형태들에 대한 설명은 3GPP LTE 방식 시스템의 경우뿐만 아니라 상향링크를 통해 데이터, 제어 신호 및 ACK/NACK 신호를 전송하는 것이 요구되는 다양한 시스템에 적용될 수 있다.



**【특허청구범위】****【청구항 1】**

ACK/NACK 신호, 상기 ACK/NACK 신호와 다른 임의의 제어 신호 및 데이터 신호를 포함한 상향링크 신호를 전송하는 방법에 있어서,

상기 제어 신호 및 상기 데이터 신호를 직렬적으로 다중화하는 단계;

상기 다중화된 신호를 복수의 심볼들 및 복수의 가상 부반송파들(virtual subcarriers)로 구성되는 특정 자원 영역 내에서 시간 축 방향을 우선적으로 하여 순차적으로 매핑하는 단계; 및

상기 ACK/NACK 신호를 상기 복수의 심볼 중 참조 신호(reference signal)가 전송되는 심볼(Symbol)에 인접하는 양 심볼에 배치하는 단계를 포함하는, 상향링크 신호 전송 방법.

**【청구항 2】**

제 1 항에 있어서,

상기 ACK/NACK 신호는 상기 다중화된 신호의 일부에 겹쳐 쓰여지는, 상향링크 신호 전송 방법.

**【청구항 3】**

제 2 항에 있어서,

상기 ACK/NACK 신호가 겹쳐 쓰여지는 상기 다중화된 신호의 일부는 상기 제어 신호 및 상기 데이터 신호 중 하나 이상을 포함하는, 상향링크 신호 전송 방법.

**【청구항 4】**

제 1 항에 있어서,

상기 특정 자원 영역에 매핑된 신호를 상기 복수의 심볼 각각을 단위로 상기 복수의 가상 부반송파의 인덱스에 따라 DFT(Discrete Furrier Transform)를 수행하는 단계;

상기 DFT된 심볼 단위 신호에 IFFT(Inverse Fast Furrier Transform)를 수행하고, 순환전치부(CP)를 부착하는 단계; 및

상기 CP가 부착된 심볼 단위 신호를 각각 SC-FDMA 심볼로서 전송하는 단계를 더 포함하는, 상향링크 신호 전송 방법.

**【청구항 5】**

제 1 항 내지 제 4 항 중 어느 한 항에 있어서,

상기 특정 자원 영역에 매핑된 신호를 물리 상향링크 공유 채널(PUSCH)을 통해 전송하는 단계를 더 포함하는, 상향링크 신호 전송 방법.

**【청구항 6】**

ACK/NACK 신호, 상기 ACK/NACK 신호와 다른 임의의 제어 신호 및 데이터 신호를 포함한 상향링크 신호를 전송하는 방법에 있어서,

상기 데이터, 상기 제어 신호 및 상기 ACK/NACK 신호에 각각 채널 코딩을 수행하는 단계;

각각 채널 코딩된 상기 데이터 및 상기 제어 신호를 직렬적으로 다중화하는

제출 일자 : 2008-07-15 1020080068634

단계;

상기 다중화된 신호를 복수의 심볼들 및 복수의 가상 부반송파들(virtual subcarriers)로 구성되는 특정 자원 영역 내에서 시간 축 방향을 우선적으로 하여 순차적으로 매핑하는 단계; 및

상기 ACK/NACK 신호를 상기 복수의 심볼 중 참조 신호(reference signal)가 전송되는 심볼(Symbol)에 인접하는 양 심볼에 배치하는 단계를 포함하는, 상향링크 신호 전송 방법.

#### 【청구항 7】

제 6 항에 있어서,

상기 데이터 신호에 채널 코딩을 수행하는 단계는,

상기 데이터 신호 전송을 위한 전송 블록에 전송 블록용 CRC를 부착하는 단계;

상기 전송 블록용 CRC가 부착된 전송 블록을 코드 블록 단위로 분할하고, 분할된 상기 코드 블록에 코드블록용 CRC를 부착하는 단계;

상기 코드블록용 CRC가 부착된 데이터에 채널 코딩을 수행하는 단계;

상기 채널 코딩된 데이터에 레이트 매칭 및 코드 블록 연결을 수행하는 단계를 포함하는, 상향링크 신호 전송 방법.

#### 【도면의 간단한 설명】

<61> 도 1은 SC-FDMA 방식으로 신호를 전송하는 방법을 설명하기 위한 송신단의

블록도이다.

- <62>           도 2는 상향링크 신호 전송을 위해 데이터, 제어 정보 및 ACK/NACK 신호의 다중화 과정을 설명하기 위한 도면이다.
- <63>           도 3은 본 발명의 일 실시형태에 따라 정보 시퀀스를 시간 축 우선 매핑 방식에 따라 매핑하는 예를 설명하는 도면이다.
- <64>           도 4 및 도 5는 도 3에 도시된 바와 같이 시간 축 우선 매핑 방식에 따라 매핑된 정보를 SC-FDMA 방식으로 전송하는 방법을 설명하는 도면들이다.
- <65>           도 6은 본 발명의 일 실시형태에 따라 상향링크 신호를 전송하는 방법을 설명하기 위한 도면이다.
- <66>           도 7 및 도 8은 본 발명의 일 실시형태에 따라 ACK/NACK 정보를 전송할 경우 중 전송되어야 할 ACK/NACK 정보의 수가 많은 경우의 처리 방법을 설명하기 위한 도면이다.
- <67>           도 9는 본 발명의 또 다른 일 실시형태에 따라 ACK/NACK 신호가 데이터뿐만 아니라 제어 신호를 평처링하여 삽입되는 형태를 도시한 도면이다.

【도면】

【도 1】

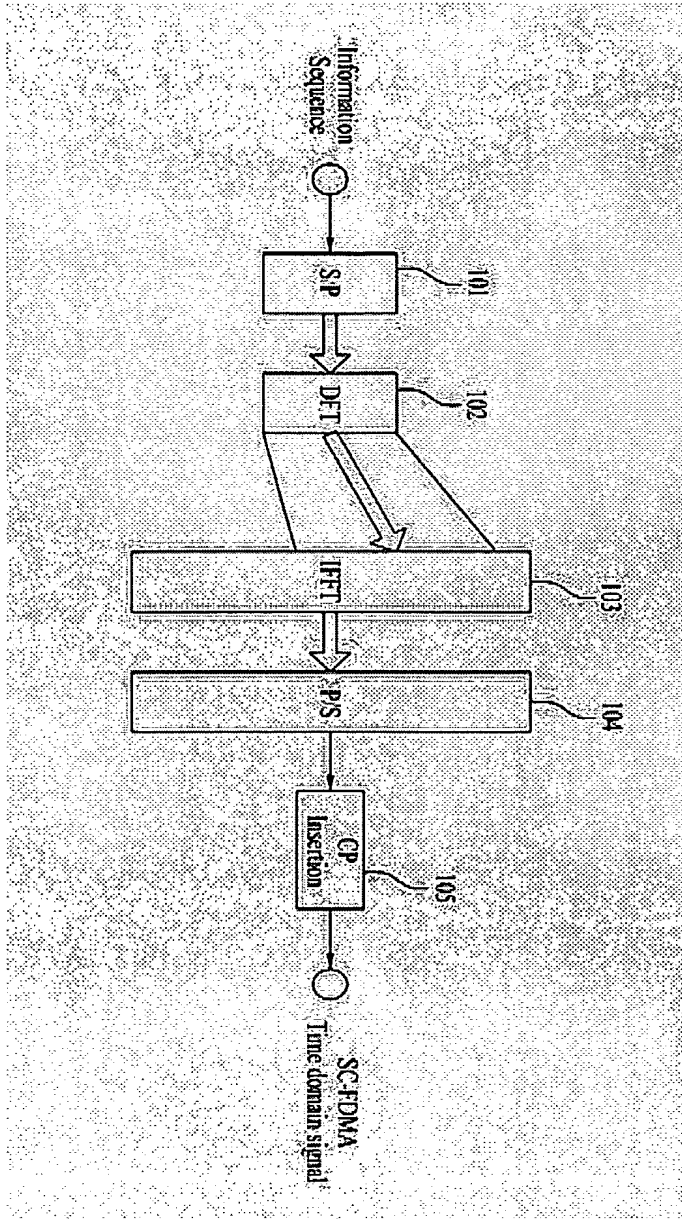

【도 2】

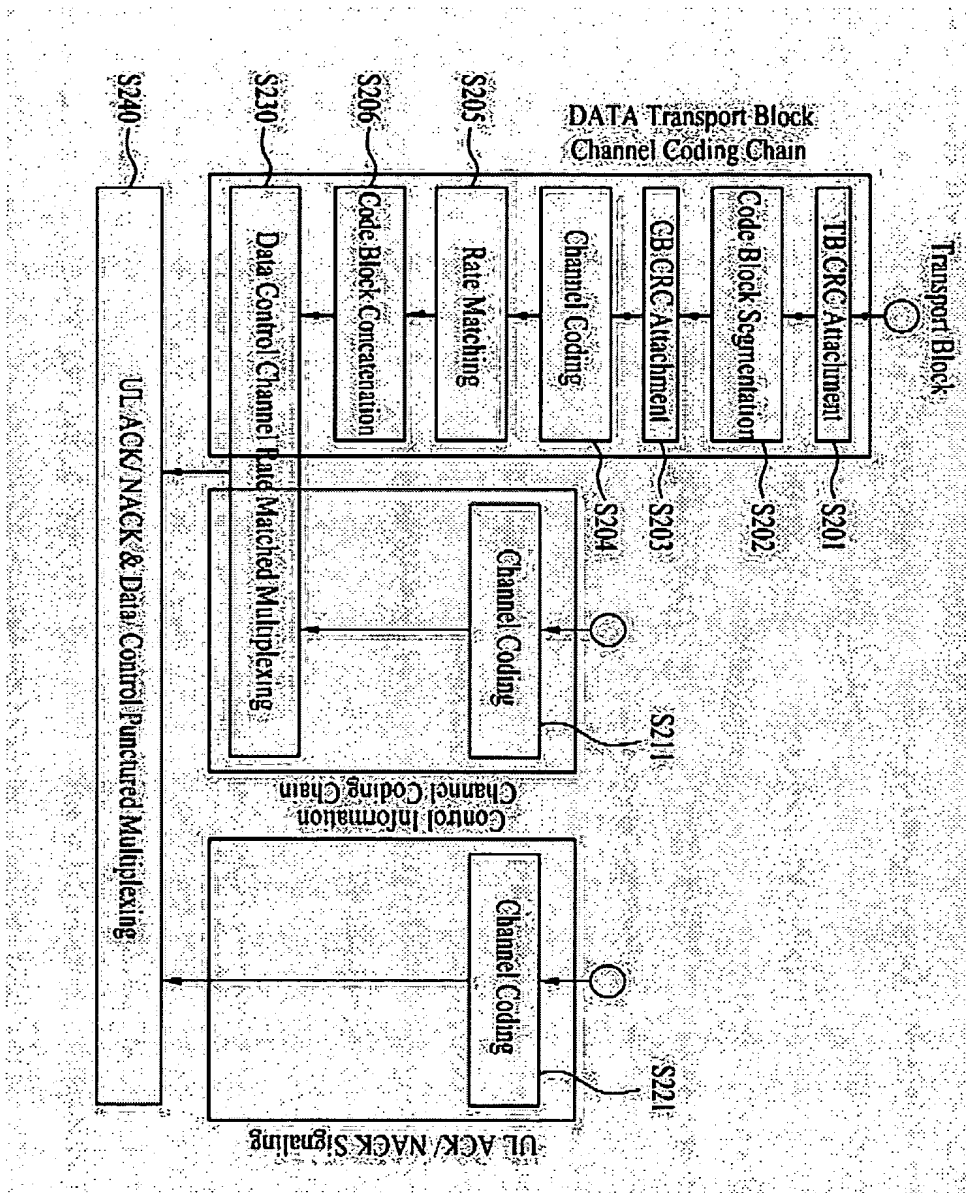

【도 3】

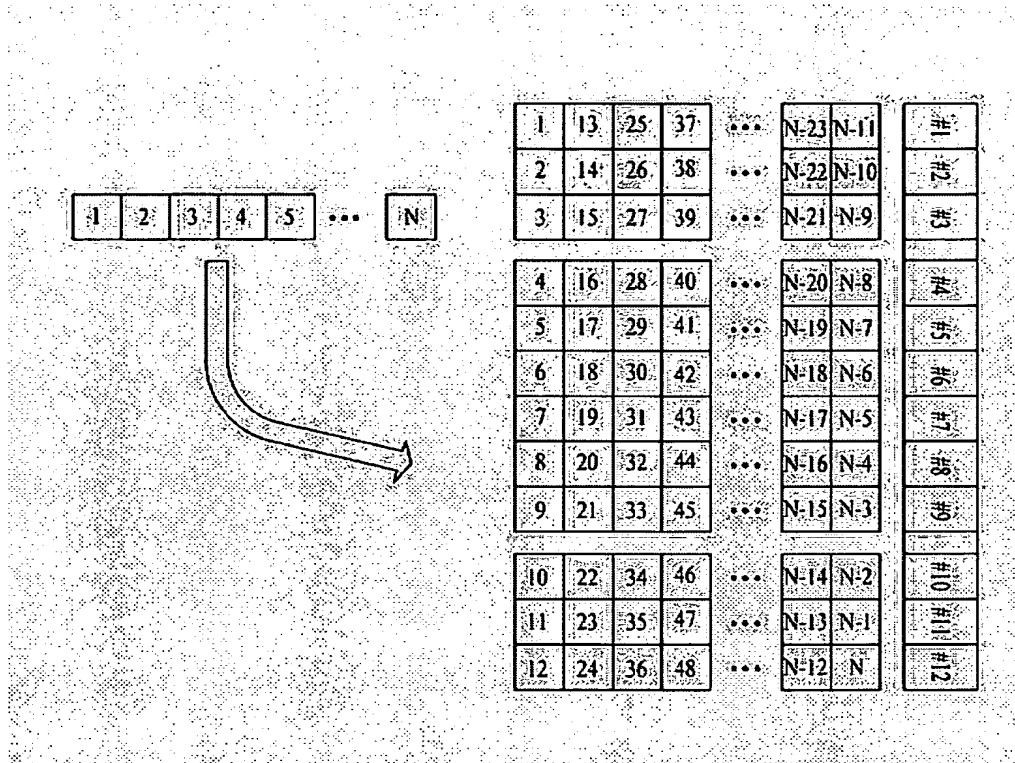

【도 4】

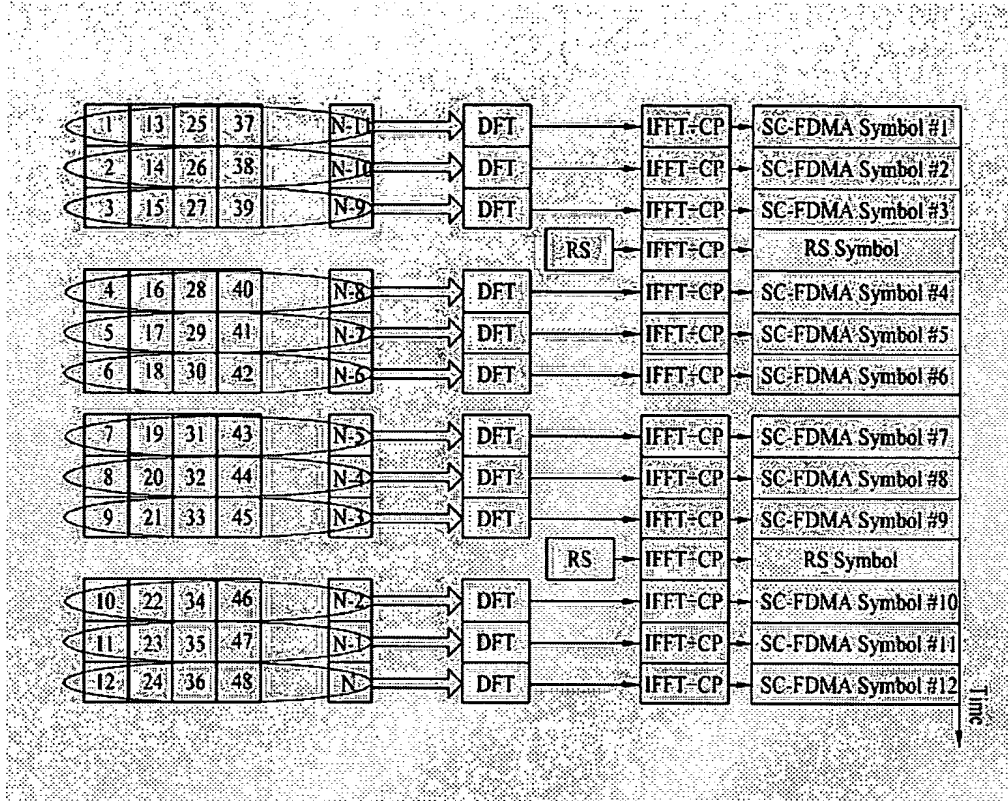



【도 5】

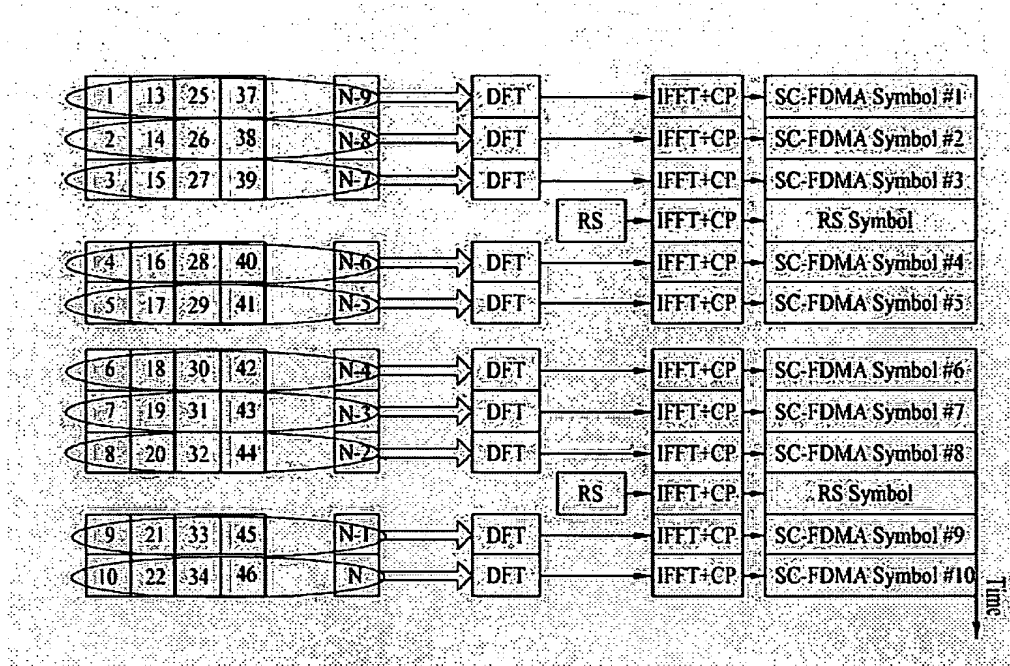

【도 6】

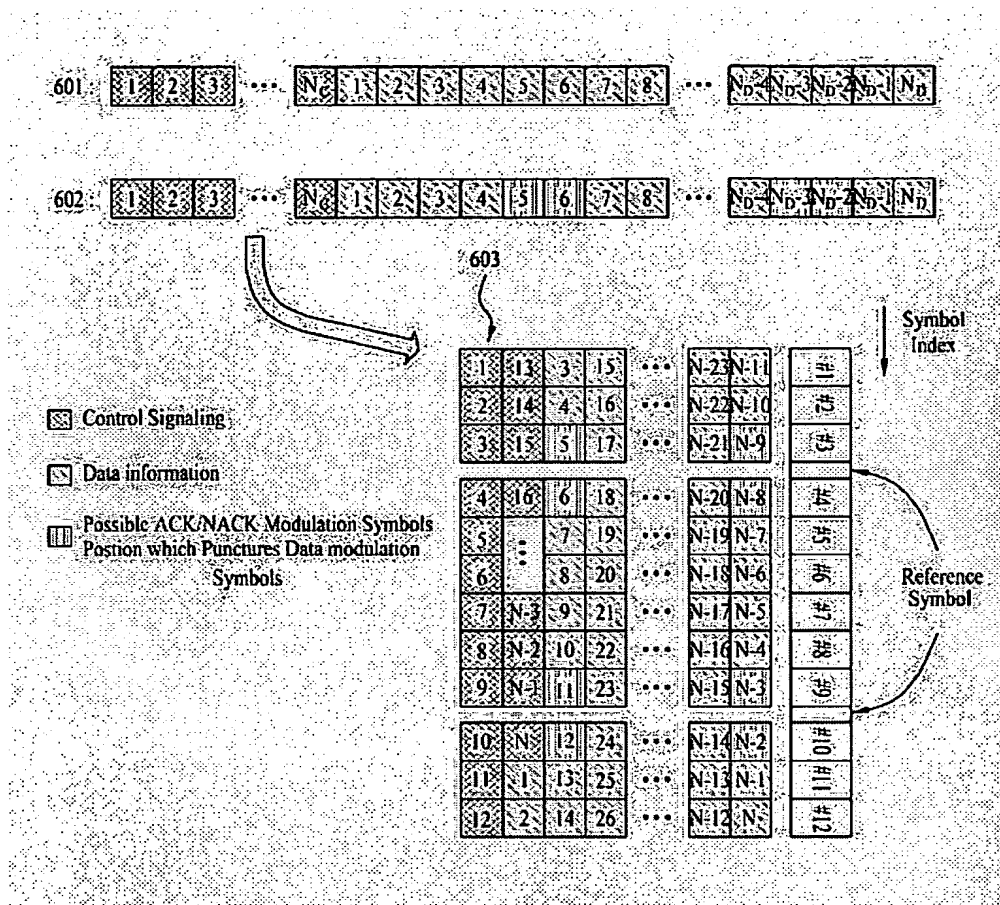

제출 일자 : 2008-07-15

1020080068634

【도 7】

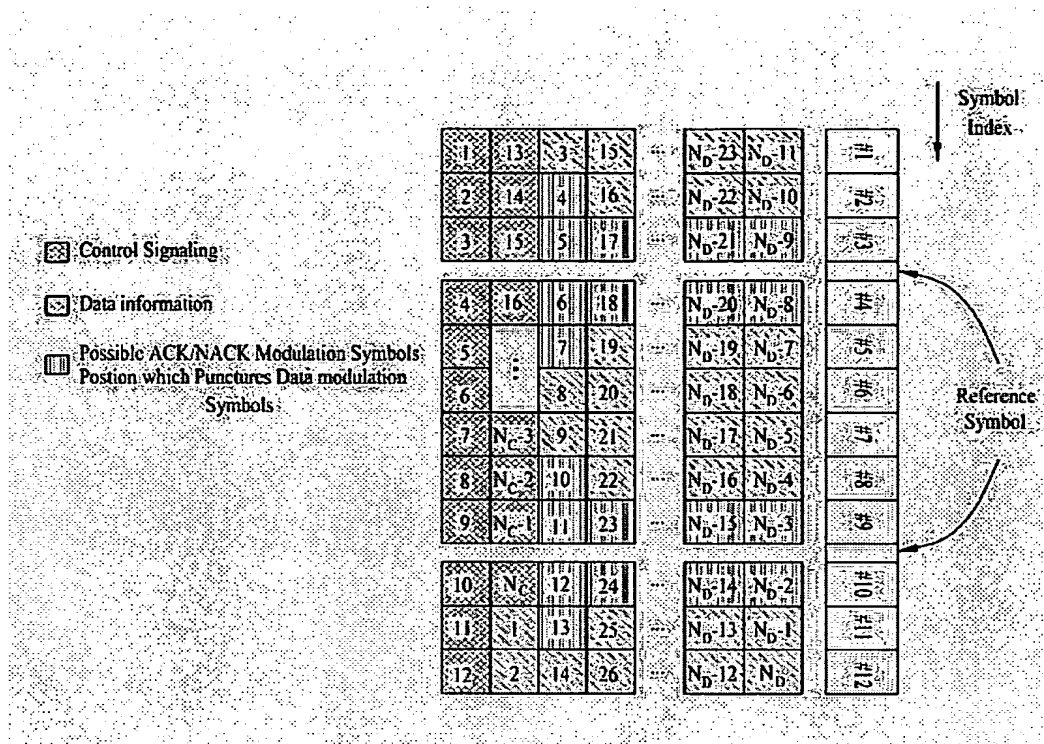

【도 8】

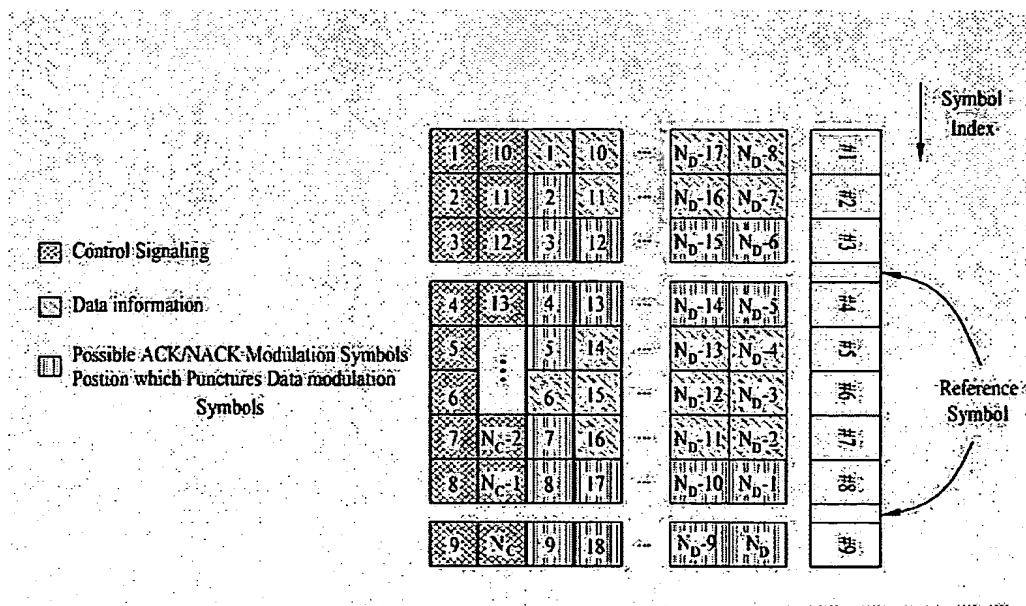

【도 9】

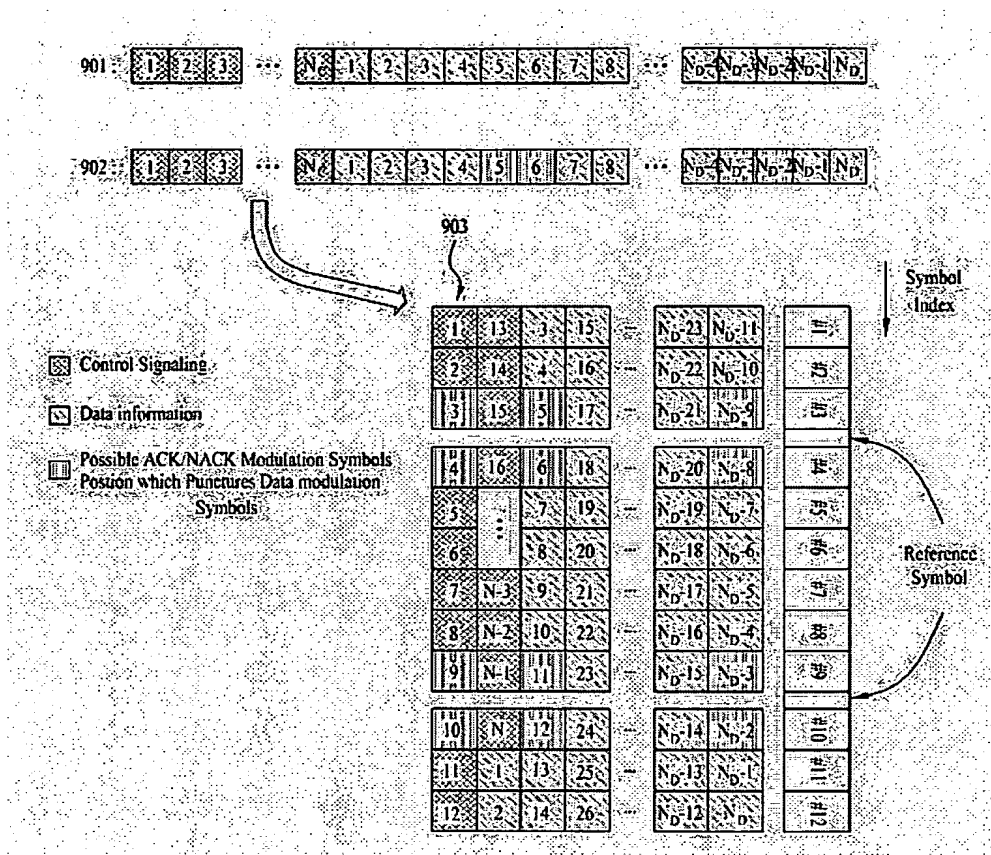

*ZW*



PATENT DOCKET NO. 2101-3573  
CUSTOMER NO. 035884

IN THE UNITED STATES PATENT AND TRADEMARK OFFICE

In re application of:  
Dae Won LEE et al.  
Serial No: 12/209,136  
Filed: September 11, 2008  
For: METHOD FOR TRANSMITTING UPLINK SIGNALS

Art Unit: 2617  
Examiner: Bost, Dwayne D.

TRANSMITTAL OF PRIORITY DOCUMENT

Commissioner for Patents  
P. O. Box 1450  
Alexandria, VA 22313-1450

Dear Sir:

Enclosed herewith is certified copy of Korean Patent Application No. 10-2008-0068634 filed on July 15, 2008, and from which priority is claimed under 35 U.S.C. Section 119 and Rule 55.

Acknowledgment of the priority document(s) is respectfully requested to ensure that the subject information appears on the printed patent.

Respectfully submitted,

LEE, HONG, DEGERMAN, KANG & WAIMEY

By: \_\_\_\_\_  
Harry S. Lee  
Registration No. 56,814

Date: October 12, 2009

Customer No. 035884

Doc code :IDS

Doc description: Information Disclosure Statement (IDS) Filed

PTO/SB/08a (10-08)

Approved for use through 11/30/2008. OMB 0651-0031

U.S. Patent and Trademark Office; U.S. DEPARTMENT OF COMMERCE

Under the Paperwork Reduction Act of 1995, no persons are required to respond to a collection of information unless it contains a valid OMB control number.

<b>INFORMATION DISCLOSURE STATEMENT BY APPLICANT</b> ( Not for submission under 37 CFR 1.99)	Application Number		12209136	
	Filing Date		2008-09-11	
	First Named Inventor	Dae Won Lee		
	Art Unit		2617	
	Examiner Name			
	Attorney Docket Number		2101-3573	

U.S.PATENTS							Remove
Examiner Initial*	Cite No	Patent Number	Kind Code <sup>1</sup>	Issue Date	Name of Patentee or Applicant of cited Document	Pages,Columns,Lines where Relevant Passages or Relevant Figures Appear	
	1						

If you wish to add additional U.S. Patent citation information please click the Add button.

Add

U.S.PATENT APPLICATION PUBLICATIONS							Remove
Examiner Initial*	Cite No	Publication Number	Kind Code <sup>1</sup>	Publication Date	Name of Patentee or Applicant of cited Document	Pages,Columns,Lines where Relevant Passages or Relevant Figures Appear	
	1	20050232138		2005-10-20	Byun et al.		
	2	20050286402		2005-12-29	Byun et al.		

If you wish to add additional U.S. Published Application citation information please click the Add button.

Add

FOREIGN PATENT DOCUMENTS								Remove
Examiner Initial*	Cite No	Foreign Document Number <sup>3</sup>	Country Code <sup>2</sup> j	Kind Code <sup>4</sup>	Publication Date	Name of Patentee or Applicant of cited Document	Pages,Columns,Lines where Relevant Passages or Relevant Figures Appear	T <sup>5</sup>
	1	10-2005-0114569	KR		2005-12-06	Samsung		<input type="checkbox"/>
	2	10-2004-0056976	KR		2004-07-01	ETRI		<input type="checkbox"/>

<b>INFORMATION DISCLOSURE STATEMENT BY APPLICANT</b> ( Not for submission under 37 CFR 1.99)	Application Number		12209136
	Filing Date		2008-09-11
	First Named Inventor	Dae Won Lee	
	Art Unit		2617
	Examiner Name		
	Attorney Docket Number		2101-3573

If you wish to add additional Foreign Patent Document citation information please click the Add button

**NON-PATENT LITERATURE DOCUMENTS**

Examiner Initials*	Cite No	Include name of the author (in CAPITAL LETTERS), title of the article (when appropriate), title of the item (book, magazine, journal, serial, symposium, catalog, etc), date, pages(s), volume-issue number(s), publisher, city and/or country where published.	T <sup>5</sup>
	1		<input type="checkbox"/>

If you wish to add additional non-patent literature document citation information please click the Add button

**EXAMINER SIGNATURE**

Examiner Signature		Date Considered	
--------------------	--	-----------------	--

\*EXAMINER: Initial if reference considered, whether or not citation is in conformance with MPEP 609. Draw line through a citation if not in conformance and not considered. Include copy of this form with next communication to applicant.

<sup>1</sup> See Kind Codes of USPTO Patent Documents at [www.USPTO.GOV](http://www.USPTO.GOV) or MPEP 901.04. <sup>2</sup> Enter office that issued the document, by the two-letter code (WIPO Standard ST.3). <sup>3</sup> For Japanese patent documents, the indication of the year of the reign of the Emperor must precede the serial number of the patent document. <sup>4</sup> Kind of document by the appropriate symbols as indicated on the document under WIPO Standard ST.16 if possible. <sup>5</sup> Applicant is to place a check mark here if English language translation is attached.

<b>INFORMATION DISCLOSURE STATEMENT BY APPLICANT</b> ( Not for submission under 37 CFR 1.99)	Application Number	12209136
	Filing Date	2008-09-11
	First Named Inventor	Dae Won Lee
	Art Unit	2617
	Examiner Name	
	Attorney Docket Number	2101-3573

**CERTIFICATION STATEMENT**

Please see 37 CFR 1.97 and 1.98 to make the appropriate selection(s):

That each item of information contained in the information disclosure statement was first cited in any communication from a foreign patent office in a counterpart foreign application not more than three months prior to the filing of the information disclosure statement. See 37 CFR 1.97(e)(1).

**OR**

That no item of information contained in the information disclosure statement was cited in a communication from a foreign patent office in a counterpart foreign application, and, to the knowledge of the person signing the certification after making reasonable inquiry, no item of information contained in the information disclosure statement was known to any individual designated in 37 CFR 1.56(c) more than three months prior to the filing of the information disclosure statement. See 37 CFR 1.97(e)(2).

See attached certification statement.

Fee set forth in 37 CFR 1.17 (p) has been submitted herewith.

None

**SIGNATURE**

A signature of the applicant or representative is required in accordance with CFR 1.33, 10.18. Please see CFR 1.4(d) for the form of the signature.

Signature	/Puya Partow-Navid/	Date (YYYY-MM-DD)	2009-05-05
Name/Print	Puya Partow-Navid	Registration Number	59,657

This collection of information is required by 37 CFR 1.97 and 1.98. The information is required to obtain or retain a benefit by the public which is to file (and by the USPTO to process) an application. Confidentiality is governed by 35 U.S.C. 122 and 37 CFR 1.14. This collection is estimated to take 1 hour to complete, including gathering, preparing and submitting the completed application form to the USPTO. Time will vary depending upon the individual case. Any comments on the amount of time you require to complete this form and/or suggestions for reducing this burden, should be sent to the Chief Information Officer, U.S. Patent and Trademark Office, U.S. Department of Commerce, P.O. Box 1450, Alexandria, VA 22313-1450. **DO NOT SEND FEES OR COMPLETED FORMS TO THIS ADDRESS. SEND TO: Commissioner for Patents, P.O. Box 1450, Alexandria, VA 22313-1450.**



## Privacy Act Statement

The Privacy Act of 1974 (P.L. 93-579) requires that you be given certain information in connection with your submission of the attached form related to a patent application or patent. Accordingly, pursuant to the requirements of the Act, please be advised that: (1) the general authority for the collection of this information is 35 U.S.C. 2(b)(2); (2) furnishing of the information solicited is voluntary; and (3) the principal purpose for which the information is used by the U.S. Patent and Trademark Office is to process and/or examine your submission related to a patent application or patent. If you do not furnish the requested information, the U.S. Patent and Trademark Office may not be able to process and/or examine your submission, which may result in termination of proceedings or abandonment of the application or expiration of the patent.

The information provided by you in this form will be subject to the following routine uses:

1. The information on this form will be treated confidentially to the extent allowed under the Freedom of Information Act (5 U.S.C. 552) and the Privacy Act (5 U.S.C. 552a). Records from this system of records may be disclosed to the Department of Justice to determine whether the Freedom of Information Act requires disclosure of these records.
2. A record from this system of records may be disclosed, as a routine use, in the course of presenting evidence to a court, magistrate, or administrative tribunal, including disclosures to opposing counsel in the course of settlement negotiations.
3. A record in this system of records may be disclosed, as a routine use, to a Member of Congress submitting a request involving an individual, to whom the record pertains, when the individual has requested assistance from the Member with respect to the subject matter of the record.
4. A record in this system of records may be disclosed, as a routine use, to a contractor of the Agency having need for the information in order to perform a contract. Recipients of information shall be required to comply with the requirements of the Privacy Act of 1974, as amended, pursuant to 5 U.S.C. 552a(m).
5. A record related to an International Application filed under the Patent Cooperation Treaty in this system of records may be disclosed, as a routine use, to the International Bureau of the World Intellectual Property Organization, pursuant to the Patent Cooperation Treaty.
6. A record in this system of records may be disclosed, as a routine use, to another federal agency for purposes of National Security review (35 U.S.C. 181) and for review pursuant to the Atomic Energy Act (42 U.S.C. 218(c)).
7. A record from this system of records may be disclosed, as a routine use, to the Administrator, General Services, or his/her designee, during an inspection of records conducted by GSA as part of that agency's responsibility to recommend improvements in records management practices and programs, under authority of 44 U.S.C. 2904 and 2906. Such disclosure shall be made in accordance with the GSA regulations governing inspection of records for this purpose, and any other relevant (i.e., GSA or Commerce) directive. Such disclosure shall not be used to make determinations about individuals.
8. A record from this system of records may be disclosed, as a routine use, to the public after either publication of the application pursuant to 35 U.S.C. 122(b) or issuance of a patent pursuant to 35 U.S.C. 151. Further, a record may be disclosed, subject to the limitations of 37 CFR 1.14, as a routine use, to the public if the record was filed in an application which became abandoned or in which the proceedings were terminated and which application is referenced by either a published application, an application open to public inspections or an issued patent.
9. A record from this system of records may be disclosed, as a routine use, to a Federal, State, or local law enforcement agency, if the USPTO becomes aware of a violation or potential violation of law or regulation.

Please Click here to view the drawing

Korean FullDoc. English Fulltext

(19)  KOREAN INTELLECTUAL PROPERTY OFFICE

KOREAN PATENT ABSTRACTS

(11)Publication number: **1020050114569 A**  
 (43)Date of publication of application: **06.12.2005**

(21)Application number: **1020040039850**  
 (22)Date of filing: **01.06.2004**  
 (30)Priority: **..**

(71)Applicant: **SAMSUNG ELECTRONICS CO., LTD.**  
 (72)Inventor: **BYUN, MYUNG KWANG  
 JEON, JAE HO  
 MAENG, SEUNG JOO  
 KIM, JEONG HEON  
 SEO, HEE SANG  
 OH, JEONG TAE**

(51)Int. Cl **H04L 27/26  
 H04J 11/00**

(54) **METHOD AND DEVICE FOR UPLINK FAST FEEDBACK INFORMATION TRANSMISSION IN OFDMA SYSTEMS BY USING NON-COHERENT MODULATION METHOD**

(57) Abstract:

PURPOSE: A method and a device for an uplink fast feedback information transmission in OFDMA systems are provided to transmit accurate information and to operate the systems stably by increasing information data bit to transmit into 5 bits or 6 bits in case of transmitting the uplink fast feedback information by using the given frequency-time base resources. CONSTITUTION: A method for an uplink fast feedback information transmission in OFDMA systems includes the steps of: outputting code words corresponding to data bit by receiving 5 bit information data bit of the uplink fast feedback information; outputting transmission symbols of a subcarrier by performing the orthogonal-modulation of the symbols for the corresponding code words of the inputted data bit; and reverse fast fourier transforming and transmitting a transmitting signal composed of subcarrier bundles allocated with the modulated transmission symbols and a pilot symbol.

부호워드	0	1	2	3	4	5	6	7	8	9	10	11	12	13	14	15
A0	0	1	2	3	4	5	6	7	0	1	2	3	4	5	6	7
A1	0	1	2	3	4	5	6	7	1	2	3	4	5	6	7	0
A2	0	1	2	3	4	5	6	7	2	3	4	5	6	7	0	1
A3	0	1	2	3	4	5	6	7	3	4	5	6	7	0	1	2
A4	0	1	2	3	4	5	6	7	4	5	6	7	0	1	2	3
A5	0	1	2	3	4	5	6	7	5	6	7	0	1	2	3	4
부호워드	16	17	18	19	20	21	22	23	24	25	26	27	28	29	30	31
A0	4	5	6	7	0	1	2	3	4	5	6	7	0	1	2	3
A1	7	0	1	2	3	4	5	6	6	7	0	1	2	3	4	5
A2	2	3	4	5	6	7	0	1	0	1	2	3	4	5	6	7
A3	5	6	7	0	1	2	3	4	2	3	4	5	6	7	0	1
A4	1	2	3	4	5	6	7	0	5	6	7	0	1	2	3	4
A5	6	7	0	1	2	3	4	5	7	0	1	2	3	4	5	6

copyright KIPO 2006

Legal Status

Date of request for an examination (20060530)

Notification date of refusal decision ( )

Final disposal of an application (registration)



(19)대한민국특허청(KR)  
(12) 등록특허공보(B1)

(51) 。 Int. Cl.	(45) 공고일자	2006년11월29일
<i>H04L 27/26</i> (2006.01)	(11) 등록번호	10-0651509
<i>H04J 11/00</i> (2006.01)	(24) 등록일자	2006년11월22일

(21) 출원번호	10-2004-0039850	(65) 공개번호	10-2005-0114569
(22) 출원일자	2004년06월01일	(43) 공개일자	2005년12월06일
심사청구일자	2006년05월30일		

(73) 특허권자           삼성전자주식회사  
                              경기도 수원시 영통구 매탄동 416

(72) 발명자            변명광  
                              경기도수원시영통구영통동벽적골8단지아파트801동1001호

                              전재호  
                              경기도성남시분당구수내동54파크타운삼익아파트121동1003호

                              맹승주  
                              경기도성남시분당구정자동정든마을한진7단지아파트704동1504호

                              김정현  
                              경기도안양시만안구안양6동522-8번지신유정타운1동B01호

                              서희상  
                              서울특별시관악구신림2동현대아파트106동711호

                              오정태  
                              경기도용인시풍덕천1동삼익아파트104동407호

(74) 대리인            이건주

(56) 선행기술조사문헌	
JP07046219 A	JP07226724 A *
JP2003264525 A	KR1020020053229 A
KR1020040056976 A	07226724
15264525 *	

\* 심사관에 의하여 인용된 문헌

심사관 : 오준철

전체 청구항 수 : 총 27 항

(54) 직교 주파수 분할 다중 접속 통신 시스템에서 상향링크 고속 피드백 정보 전송 방법 및 장치

(57) 요약

본 발명은, 직교 주파수 분할 다중 접속 시스템에서 상향링크의 제어 정보 중의 하나인 고속 피드백 정보를 전송하기 위한 방법 및 장치에 관한 것이다. 이를 위해 본 발명은, 직교 주파수 분할 다중 접속 방식을 사용하는 통신 시스템에서, 고속 피드백 채널을 이용한 상향링크 고속 피드백 정보를 전송하는 방법에 있어서, 전송하고자 하는 상향링크 고속 피드백 정보를 생성하고, 상기 고속 피드백 정보에 상응하여 모든 가능한 두 부호워드들 간의 임의의 쌍에 대한 최소 해밍 거리가 최대가 되는 부호워드들을 출력하는 과정과, 상기 출력한 부호워드들에 상응하는 전송 심벌들을 직교 변조하고, 상기 직교 변조한 전송 심벌들을 부반송파 묶음에 할당하는 과정과, 상기 부반송파 묶음으로 이루어진 전송 신호를 역고속 푸리에 변환하고, 상기 역고속 푸리에 변환한 전송 신호를 전송하는 과정을 포함한다.

대표도

도 9

## 특허청구의 범위

### 청구항 1.

직교 주파수 분할 다중 접속 방식을 사용하는 통신 시스템에서, 고속 피드백 채널을 이용한 상향링크 고속 피드백 정보를 전송하는 방법에 있어서,

전송하고자 하는 상향링크 고속 피드백 정보를 생성하고, 상기 고속 피드백 정보에 상응하여 모든 가능한 두 부호워드들 간의 임의의 쌍에 대한 최소 해밍 거리가 최대가 되는 부호워드들을 출력하는 과정과,

상기 출력한 부호워드들에 상응하는 전송 심벌들을 직교 변조하고, 상기 직교 변조한 전송 심벌들을 부반송파 묶음에 할당하는 과정과,

상기 부반송파 묶음으로 이루어진 전송 신호를 역고속 푸리에 변환하고, 상기 역고속 푸리에 변환한 전송 신호를 전송하는 과정을 포함함을 특징으로 하는 고속 피드백 정보 전송 방법.

### 청구항 2.

제1항에 있어서,

상기 전송 심벌은, 상기 직교 변조를 사용하여 하기의 P0, P1, P2 및 P3과 같이 정의된 직교 벡터들의 집합으로 이루어지고, 상기 직교 변조한 심벌들은 QPSK(Quadrature Phase Shift Keying) 변조 심벌들을 포함하는 것을 특징으로 하는 고속 피드백 정보 전송 방법.

$$P0 = \exp\left(j\frac{\pi}{4}\right)$$

$$P1 = \exp\left(j\frac{3\pi}{4}\right)$$

$$P2 = \exp\left(-j\frac{3\pi}{4}\right)$$

$$P3 = \exp\left(-j\frac{\pi}{4}\right)$$

### 청구항 3.

제2항에 있어서,

상기 직교 벡터들의 집합은 하기와 같이 정의됨을 특징으로 하는 고속 피드백 정보 전송 방법.

벡터 인덱스	부호워드 당 부반송파 변조 부반송파 0, 부반송파 1, . . . 부반송파 7
0	P0, P1, P2, P3, P0, P1, P2, P3
1	P0, P3, P2, P1, P0, P3, P2, P1
2	P0, P0, P1, P1, P2, P2, P3, P3
3	P0, P0, P3, P3, P2, P2, P1, P1
4	P0, P0, P0, P0, P0, P0, P0, P0
5	P0, P2, P0, P2, P0, P2, P0, P2
6	P0, P2, P0, P2, P2, P0, P2, P0
7	P0, P2, P2, P0, P2, P0, P0, P2

#### 청구항 4.

제1항에 있어서,

상기 직교 변조에 사용되는 패턴에 상응하여 상기 상향링크 고속 피드백 정보로 5비트의 정보 데이터 비트를 이용함을 특징으로 하는 고속 피드백 정보 전송 방법.

#### 청구항 5.

제1항에 있어서,

상기 직교 변조에 사용되는 패턴에 상응하여 상기 상향링크 고속 피드백 정보로 6비트의 정보 데이터 비트를 이용함을 특징으로 하는 고속 피드백 정보 전송 방법.

#### 청구항 6.

제1항에 있어서,

상기 부호워드들은, 하기와 같이 정의된 5비트 정보 데이터 비트를 포함하는 것을 특징으로 하는 고속 피드백 정보 전송 방법.

부호워드	0	1	2	3	4	5	6	7	8	9	10	11	12	13	14	15
A0	0	1	2	3	4	5	6	7	0	1	2	3	4	5	6	7
A1	0	1	2	3	4	5	6	7	1	2	3	4	5	6	7	0
A2	0	1	2	3	4	5	6	7	2	3	4	5	6	7	0	1
A3	0	1	2	3	4	5	6	7	3	4	5	6	7	0	1	2
A4	0	1	2	3	4	5	6	7	4	5	6	7	0	1	2	3
A5	0	1	2	3	4	5	6	7	5	6	7	0	1	2	3	4
부호워드	16	17	18	19	20	21	22	23	24	25	26	27	28	29	30	31
A0	4	5	6	7	0	1	2	3	4	5	6	7	0	1	2	3
A1	7	0	1	2	3	4	5	6	6	7	0	1	2	3	4	5
A2	2	3	4	5	6	7	0	1	0	1	2	3	4	5	6	7
A3	5	6	7	0	1	2	3	4	2	3	4	5	6	7	0	1
A4	1	2	3	4	5	6	7	0	5	6	7	0	1	2	3	4
A5	6	7	0	1	2	3	4	5	7	0	1	2	3	4	5	6

### 청구항 7.

제1항에 있어서,

상기 부호워드들은, 하기와 같이 정의된 6비트 정보 데이터 비트를 포함하는 것을 특징으로 하는 고속 피드백 정보 전송 방법.

부호워드	0	1	2	3	4	5	6	7	8	9	10	11	12	13	14	15
A0	0	1	2	3	4	5	6	7	2	3	0	1	6	7	4	5
A1	0	1	2	3	4	5	6	7	4	5	6	7	0	1	2	3
A2	0	1	2	3	4	5	6	7	3	2	1	0	7	6	5	4
A3	0	1	2	3	4	5	6	7	6	7	4	5	2	3	0	1
A4	0	1	2	3	4	5	6	7	7	6	5	4	3	2	1	0
A5	0	1	2	3	4	5	6	7	5	4	7	6	1	0	3	2
부호워드	16	17	18	19	20	21	22	23	24	25	26	27	28	29	30	31
A0	4	5	6	7	0	1	2	3	3	2	1	0	7	6	5	4
A1	3	2	1	0	7	6	5	4	6	7	4	5	2	3	0	1
A2	6	7	4	5	2	3	0	1	7	6	5	4	3	2	1	0
A3	7	6	5	4	3	2	1	0	5	4	7	6	1	0	3	2
A4	5	4	7	6	1	0	3	2	1	0	3	2	5	4	7	6
A5	1	0	3	2	5	4	7	6	2	3	0	1	6	7	4	5
부호워드	32	33	34	35	36	37	38	39	40	41	42	43	44	45	46	47
A0	6	7	4	5	2	3	0	1	7	6	5	4	3	2	1	0
A1	7	6	5	4	3	2	1	0	5	4	7	6	1	0	3	2
A2	5	4	7	6	1	0	3	2	1	0	3	2	5	4	7	6
A3	1	0	3	2	5	4	7	6	2	3	0	1	6	7	4	5
A4	2	3	0	1	6	7	4	5	4	5	6	7	0	1	2	3
A5	4	5	6	7	0	1	2	3	3	2	1	0	7	6	5	4
부호워드	48	49	50	51	52	53	54	55	56	57	58	59	60	61	62	63
A0	5	4	7	6	1	0	3	2	1	0	3	2	5	4	7	6
A1	1	0	3	2	5	4	7	6	2	3	0	1	6	7	4	5
A2	2	3	0	1	6	7	4	5	4	5	6	7	0	1	2	3
A3	4	5	6	7	0	1	2	3	3	2	1	0	7	6	5	4
A4	3	2	1	0	7	6	5	4	6	7	4	5	2	3	0	1
A5	6	7	4	5	2	3	0	1	7	6	5	4	3	2	1	0

청구항 8.

제1항에 있어서, 상기 직교 변조 과정은,

상기 고속 피드백 정보에 상응하여 소정 크기의 정보 데이터 비트를 수신하면, 미리 설정된 변조 패턴에 상응하여 상기 부호워드들을 결정하는 과정과,

상기 결정된 부호워드들에 상응하는 전송 심벌들을 직교 변조하는 과정과,

상기 부반송파 묶음에 상기 변조된 전송 심벌들 및 파일럿 심벌을 할당하는 과정을 포함하는 것을 특징으로 하는 고속 피드백 정보 전송 방법.

청구항 9.

직교 주파수 분할 다중 접속 방식을 사용하는 통신 시스템에서, 고속 피드백 채널에 사용할 상향링크 고속 피드백 정보를 전송하는 위한 방법에 있어서,

상기 상향링크 고속 피드백 정보의 5비트 정보 데이터 비트를 수신하고, 상기 수신한 정보 데이터 비트에 상응하는 부호워드들을 출력하는 과정과,

상기 수신된 정보 데이터 비트의 해당 부호워드에 상응하는 심벌들을 직교 변조하고, 상기 직교 변조된 전송 심벌들을 출력하는 과정과,

상기 변조된 전송 심벌들 및 파일럿 심벌이 할당된 부반송파 묶음들로 이루어진 송신 신호를 역고속 푸리에 변환하고, 상기 역고속 푸리에 변환된 전송 신호를 전송하는 과정을 포함하는 것을 특징으로 하는 고속 피드백 정보 전송 방법.

#### 청구항 10.

제9항에 있어서,

상기 부호워드들은, 모든 가능한 두 부호워드들 간의 임의의 쌍에 대한 최소 해밍 거리가 최대가 되도록 설정됨을 특징으로 하는 고속 피드백 정보 전송 방법.

#### 청구항 11.

제9항에 있어서,

상기 직교 변조에 사용되는 패턴에 상응하여 상기 상향링크 고속 피드백 정보로 5비트의 정보 데이터 비트를 이용함을 특징으로 하는 고속 피드백 정보 전송 방법.

#### 청구항 12.

제9항에 있어서,

상기 부호워드들은, 하기와 같이 정의된 5비트 정보 데이터 비트를 포함하는 것을 특징으로 하는 고속 피드백 정보 전송 방법.



부호워드	0	1	2	3	4	5	6	7	8	9	10	11	12	13	14	15
A0	0	1	2	3	4	5	6	7	0	1	2	3	4	5	6	7
A1	0	1	2	3	4	5	6	7	1	2	3	4	5	6	7	0
A2	0	1	2	3	4	5	6	7	2	3	4	5	6	7	0	1
A3	0	1	2	3	4	5	6	7	3	4	5	6	7	0	1	2
A4	0	1	2	3	4	5	6	7	4	5	6	7	0	1	2	3
A5	0	1	2	3	4	5	6	7	5	6	7	0	1	2	3	4
부호워드	16	17	18	19	20	21	22	23	24	25	26	27	28	29	30	31
A0	4	5	6	7	0	1	2	3	4	5	6	7	0	1	2	3
A1	7	0	1	2	3	4	5	6	6	7	0	1	2	3	4	5
A2	2	3	4	5	6	7	0	1	0	1	2	3	4	5	6	7
A3	5	6	7	0	1	2	3	4	2	3	4	5	6	7	0	1
A4	1	2	3	4	5	6	7	0	5	6	7	0	1	2	3	4
A5	6	7	0	1	2	3	4	5	7	0	1	2	3	4	5	6

### 청구항 13.

제9항에 있어서, 상기 직교 변조하는 과정은,

상기 5비트의 정보 데이터 비트를 수신하면, 미리 설정된 변조 패턴에 상응하여 부호워드들을 결정하는 과정과,

상기 결정된 부호워드들에 상응하는 전송 심벌들을 직교 변조하는 과정과,

상기 부반송파 묶음에 상기 변조된 전송 심벌들 및 파일럿 심벌을 할당하는 과정을 포함하는 것을 특징으로 하는 고속 피드백 정보 전송 방법.

### 청구항 14.

직교 주파수 분할 다중 접속 방식을 사용하는 통신 시스템에서, 고속 피드백 채널에 사용할 상향링크 고속 피드백 정보를 전송하는 방법에 있어서,

상기 상향링크 고속 피드백 정보의 6비트 정보 데이터 비트를 수신하고, 상기 수신한 정보 데이터 비트에 상응하는 부호워드들을 출력하는 과정과,

상기 수신된 정보 데이터 비트의 해당 부호워드에 상응하는 심벌들을 직교 변조하고, 상기 직교 변조된 전송 심벌들을 출력하는 과정과,

상기 변조된 전송 심벌들 및 파일럿 심벌이 할당된 부반송파 묶음들로 이루어진 송신 신호를 역고속 푸리에 변환하고, 상기 역고속 푸리에 변환된 전송 신호를 전송하는 과정을 포함하는 것을 특징으로 하는 고속 피드백 정보 전송 방법.

### 청구항 15.

제14항에 있어서,

상기 부호워드들은, 모든 가능한 두 부호워드들 간의 임의의 쌍에 대해 최소 해밍 거리가 최대가 되도록 설정됨을 특징으로 하는 고속 피드백 정보 전송 방법.

### 청구항 16.

제14항에 있어서,

상기 전송 심벌은, 상기 직교 변조를 사용하여 하기의 P0, P1, P2 및 P3과 같이 정의된 직교 벡터들의 집합으로 이루어지고, 상기 직교 변조한 심벌들은 QPSK(Quadrature Phase Shift Keying) 변조 심벌들을 포함하는 것을 특징으로 하는 고속 피드백 정보 전송 방법.

$$P0 = \exp\left(j\frac{\pi}{4}\right)$$

$$P1 = \exp\left(j\frac{3\pi}{4}\right)$$

$$P2 = \exp\left(-j\frac{3\pi}{4}\right)$$

$$P3 = \exp\left(-j\frac{\pi}{4}\right)$$

### 청구항 17.

제16항에 있어서,

상기 직교 벡터들의 집합은 하기와 같이 정의됨을 특징으로 하는 고속 피드백 정보 전송 방법.

벡터 인덱스	부호워드 당 부반송파 변조 부반송파 0, 부반송파 1, . . . 부반송파 7
0	P0, P1, P2, P3, P0, P1, P2, P3
1	P0, P3, P2, P1, P0, P3, P2, P1
2	P0, P0, P1, P1, P2, P2, P3, P3
3	P0, P0, P3, P3, P2, P2, P1, P1
4	P0, P0, P0, P0, P0, P0, P0, P0
5	P0, P2, P0, P2, P0, P2, P0, P2
6	P0, P2, P0, P2, P2, P0, P2, P0
7	P0, P2, P2, P0, P2, P0, P0, P2

**청구항 18.**

제14항에 있어서,

상기 직교 변조에 사용되는 패턴에 상응하여 상기 상향링크 고속 피드백 정보로 6비트의 정보 데이터 비트를 이용함을 특징으로 하는 고속 피드백 정보 전송 방법.

**청구항 19.**

제14항에 있어서,

상기 부호워드들은, 하기와 같이 정의된 6비트 정보 데이터 비트를 포함하는 것을 특징으로 하는 고속 피드백 정보 전송 방법.

부호워드	0	1	2	3	4	5	6	7	8	9	10	11	12	13	14	15
A0	0	1	2	3	4	5	6	7	2	3	0	1	6	7	4	5
A1	0	1	2	3	4	5	6	7	4	5	6	7	0	1	2	3
A2	0	1	2	3	4	5	6	7	3	2	1	0	7	6	5	4
A3	0	1	2	3	4	5	6	7	6	7	4	5	2	3	0	1
A4	0	1	2	3	4	5	6	7	7	6	5	4	3	2	1	0
A5	0	1	2	3	4	5	6	7	5	4	7	6	1	0	3	2
부호워드	16	17	18	19	20	21	22	23	24	25	26	27	28	29	30	31
A0	4	5	6	7	0	1	2	3	3	2	1	0	7	6	5	4
A1	3	2	1	0	7	6	5	4	6	7	4	5	2	3	0	1
A2	6	7	4	5	2	3	0	1	7	6	5	4	3	2	1	0
A3	7	6	5	4	3	2	1	0	5	4	7	6	1	0	3	2
A4	5	4	7	6	1	0	3	2	1	0	3	2	5	4	7	6
A5	1	0	3	2	5	4	7	6	2	3	0	1	6	7	4	5
부호워드	32	33	34	35	36	37	38	39	40	41	42	43	44	45	46	47
A0	6	7	4	5	2	3	0	1	7	6	5	4	3	2	1	0
A1	7	6	5	4	3	2	1	0	5	4	7	6	1	0	3	2
A2	5	4	7	6	1	0	3	2	1	0	3	2	5	4	7	6
A3	1	0	3	2	5	4	7	6	2	3	0	1	6	7	4	5
A4	2	3	0	1	6	7	4	5	4	5	6	7	0	1	2	3
A5	4	5	6	7	0	1	2	3	3	2	1	0	7	6	5	4
부호워드	48	49	50	51	52	53	54	55	56	57	58	59	60	61	62	63
A0	5	4	7	6	1	0	3	2	1	0	3	2	5	4	7	6
A1	1	0	3	2	5	4	7	6	2	3	0	1	6	7	4	5
A2	2	3	0	1	6	7	4	5	4	5	6	7	0	1	2	3
A3	4	5	6	7	0	1	2	3	3	2	1	0	7	6	5	4
A4	3	2	1	0	7	6	5	4	6	7	4	5	2	3	0	1
A5	6	7	4	5	2	3	0	1	7	6	5	4	3	2	1	0

**청구항 20.**

제14항에 있어서, 상기 직교 변조하는 과정은,

상기 6비트의 정보 데이터 비트를 수신하면, 미리 설정된 변조 패턴에 상응하여 부호워드들을 결정하는 과정과,

상기 결정된 부호워드들에 상응하는 전송 심벌들을 직교 변조하는 과정과,

상기 부반송파 묶음에 상기 변조된 부반송파의 전송 심벌들 및 파일럿 심벌을 할당하여 출력하는 과정을 포함하는 것을 특징으로 하는 고속 피드백 전송 방법.

**청구항 21.**

직교 주파수 분할 다중 접속 방식을 사용하는 통신 시스템에서, 고속 피드백 채널을 이용한 상향링크 고속 피드백 정보를 전송하는 장치에 있어서,

전송하고자 하는 상향링크 고속 피드백 정보를 생성하고, 상기 고속 피드백 정보에 상응하여 모든 가능한 두 부호워드들 간의 임의의 쌍에 대한 최소 해밍 거리가 최대가 되는 부호워드들을 출력하는 채널 부호기와,

상기 출력한 부호워드들에 상응하는 전송 심벌들을 직교 변조하고, 상기 직교 변조한 전송 심벌들을 부반송파 묶음에 할당하여 출력하는 년코히런트 변조기와,

상기 부반송파 묶음으로 이루어진 전송 신호를 역고속 푸리에 변환하고, 상기 역고속 푸리에 변환한 전송 신호를 전송하는 역고속 푸리에 변환기를 포함함을 특징으로 하는 고속 피드백 정보 전송 장치.

## 청구항 22.

제21항에 있어서,

상기 채널 부호기는, 상기 직교 변조에 사용되는 패턴에 상응하여 상기 상향링크 고속 피드백 정보로 5비트의 정보 데이터 비트를 이용함을 특징으로 하는 고속 피드백 정보 전송 장치.

## 청구항 23.

제21항에 있어서,

상기 채널 부호기는, 상기 직교 변조에 사용되는 패턴에 상응하여 상기 상향링크 고속 피드백 정보로 6비트의 정보 데이터 비트를 이용함을 특징으로 하는 고속 피드백 정보 전송 장치.

## 청구항 24.

제21항에 있어서,

상기 채널 부호기는, 하기와 같이 정의된 5비트 정보 데이터 비트를 포함하는 것을 특징으로 하는 고속 피드백 정보 전송 장치.

부호워드	0	1	2	3	4	5	6	7	8	9	10	11	12	13	14	15
A0	0	1	2	3	4	5	6	7	0	1	2	3	4	5	6	7
A1	0	1	2	3	4	5	6	7	1	2	3	4	5	6	7	0
A2	0	1	2	3	4	5	6	7	2	3	4	5	6	7	0	1
A3	0	1	2	3	4	5	6	7	3	4	5	6	7	0	1	2
A4	0	1	2	3	4	5	6	7	4	5	6	7	0	1	2	3
A5	0	1	2	3	4	5	6	7	5	6	7	0	1	2	3	4
부호워드	16	17	18	19	20	21	22	23	24	25	26	27	28	29	30	31
A0	4	5	6	7	0	1	2	3	4	5	6	7	0	1	2	3
A1	7	0	1	2	3	4	5	6	6	7	0	1	2	3	4	5
A2	2	3	4	5	6	7	0	1	0	1	2	3	4	5	6	7
A3	5	6	7	0	1	2	3	4	2	3	4	5	6	7	0	1
A4	1	2	3	4	5	6	7	0	5	6	7	0	1	2	3	4
A5	6	7	0	1	2	3	4	5	7	0	1	2	3	4	5	6

**청구항 25.**

제21항에 있어서,

상기 채널 부호기는, 하기와 같이 정의된 6비트 정보 데이터 비트를 포함하는 것을 특징으로 하는 고속 피드백 정보 전송 장치.

부호워드	0	1	2	3	4	5	6	7	8	9	10	11	12	13	14	15
A0	0	1	2	3	4	5	6	7	2	3	0	1	6	7	4	5
A1	0	1	2	3	4	5	6	7	4	5	6	7	0	1	2	3
A2	0	1	2	3	4	5	6	7	3	2	1	0	7	6	5	4
A3	0	1	2	3	4	5	6	7	6	7	4	5	2	3	0	1
A4	0	1	2	3	4	5	6	7	7	6	5	4	3	2	1	0
A5	0	1	2	3	4	5	6	7	5	4	7	6	1	0	3	2
부호워드	16	17	18	19	20	21	22	23	24	25	26	27	28	29	30	31
A0	4	5	6	7	0	1	2	3	3	2	1	0	7	6	5	4
A1	3	2	1	0	7	6	5	4	6	7	4	5	2	3	0	1
A2	6	7	4	5	2	3	0	1	7	6	5	4	3	2	1	0
A3	7	6	5	4	3	2	1	0	5	4	7	6	1	0	3	2
A4	5	4	7	6	1	0	3	2	1	0	3	2	5	4	7	6
A5	1	0	3	2	5	4	7	6	2	3	0	1	6	7	4	5
부호워드	32	33	34	35	36	37	38	39	40	41	42	43	44	45	46	47
A0	6	7	4	5	2	3	0	1	7	6	5	4	3	2	1	0
A1	7	6	5	4	3	2	1	0	5	4	7	6	1	0	3	2
A2	5	4	7	6	1	0	3	2	1	0	3	2	5	4	7	6
A3	1	0	3	2	5	4	7	6	2	3	0	1	6	7	4	5
A4	2	3	0	1	6	7	4	5	4	5	6	7	0	1	2	3
A5	4	5	6	7	0	1	2	3	3	2	1	0	7	6	5	4
부호워드	48	49	50	51	52	53	54	55	56	57	58	59	60	61	62	63
A0	5	4	7	6	1	0	3	2	1	0	3	2	5	4	7	6
A1	1	0	3	2	5	4	7	6	2	3	0	1	6	7	4	5
A2	2	3	0	1	6	7	4	5	4	5	6	7	0	1	2	3
A3	4	5	6	7	0	1	2	3	3	2	1	0	7	6	5	4
A4	3	2	1	0	7	6	5	4	6	7	4	5	2	3	0	1
A5	6	7	4	5	2	3	0	1	7	6	5	4	3	2	1	0

**청구항 26.**

제21항에 있어서, 상기 낸코히런트 변조기는,

상기 고속 피드백 정보에 상응하여 소정 크기의 정보 데이터 비트를 수신하면, 미리 설정된 변조 패턴에 상응하여 상기 부호워드들을 결정하고, 상기 결정된 부호워드들에 상응하는 전송 심벌들을 직교 변조하는 것을 특징으로 하는 고속 피드백 정보 전송 장치.

**청구항 27.**

제21항에 있어서,

상기 낸코히런트 변조기는, 소정 크기의 정보 데이터 비트에 상응하는 미리 설정된 변조 패턴에 따라 전송 심벌값을 설정함을 특징으로 하는 고속 피드백 정보 전송 장치.

명세서

## 발명의 상세한 설명

### 발명의 목적

발명이 속하는 기술 및 그 분야의 종래기술

본 발명은 이동 통신 시스템에서 제어 정보 전송 방법 및 장치에 관한 것으로서, 특히 직교 주파수 분할 다중 접속 시스템에서 상향 링크의 제어 정보중의 하나인 고속 피드백 정보를 전송하기 위한 방법 및 장치에 관한 것이다.

현재 이동 통신 시스템은 아날로그 방식의 1세대, 디지털 방식의 2세대, IMT-2000의 고속 멀티미디어 서비스를 제공하는 3세대에 이어 초고속 멀티미디어 서비스를 제공하는 4세대 이동통신 시스템으로 발전하고 있는 추세이다. 이러한 4세대 이동통신 시스템은 하나의 단말기로 위성망, 무선랜(LAN), 인터넷망 등을 모두 사용할 수 있다. 즉 음성, 화상, 멀티미디어, 인터넷데이터, 음성메일, 인스턴트메시지(IM) 등의 모든 서비스를 이동 단말 하나로 해결할 수 있다. 이러한 4세대 이동통신 시스템은 초속 멀티미디어 서비스를 위해 20Mbps의 전송 속도를 목표로 하고 있으며, 주로 직교 분할 다중(Orthogonal Frequency Division Multiplexing 이하, OFDM) 방식과 같이 직교 주파수 분할 다중 방식을 사용하고 있다.

상기 OFDM 방식은 다수의 직교하는 반송파 신호를 다중화하는 디지털 변조방식으로서, 단일 데이터 스트림(datastream)을 여러 개의 저속의 스트림으로 분할하여 낮은 전송률의 여러 부반송파(subcarrier)를 이용하여 동시에 전송한다.

한편, 상기 OFDM 방식에 기반한 다중 접속 방식이 직교 주파수 분할 다중 접속(Orthogonal Frequency Division Multiple Access, 이하 'OFDMA'라 칭하기로 한다)이다. 상기 OFDMA 방식은 한 개의 OFDM 심벌 내의 부반송파들을 다수의 사용자들, 즉 다수의 가입자 단말기들이 분할하여 사용하는 방식이다. 상기 OFDMA 방식을 기반으로 하는 통신 시스템에서는 상향링크 제어정보 중의 하나인 상향링크 고속 피드백(FAST FEEDBACK) 정보를 전송하기 위한 별도의 물리적 채널들이 존재하게 된다. 상기 상향링크 고속 피드백 정보로는 완전 신호대 잡음비(Signal to Noise ratio, 이하 'SNR'이라 칭하기로 한다), 밴드별 차분 SNR, 고속 다중 입력 다중 출력(Multi Input Multi Output, 이하 'MIMO'라 칭하기로 한다) 피드백, 모드 선택 피드백 등이 있다. 그러면 이하에서는, 첨부한 도면들을 참조하여 상기 OFDMA 통신 시스템에서 상향링크 고속 피드백 정보를 송수신하는 일반적인 단말기의 송신기 및 기지국 수신기의 구조에 대하여 설명하기로 한다.

도 1은 종래 기술에 따른 직교 주파수 분할 다중 접속 시스템에서 상향링크 제어정보 전송을 위한 단말 송신기 구조를 개략적으로 도시한 도면이다.

상기 도 1을 참조하면, 상기 송신기(10)는 이진 채널 부호기(Binary Channel Encoder)(11)와, 변조기(Modulator)(12) 및 역고속 푸리에 변환(Inverse Fast Fourier Transform, 이하 'IFFT'라 칭하기로 한다)기(13)를 포함한다.

상기 이진 채널 부호기(11)는 전송하고자 하는 상향링크 제어정보의 정보 데이터 비트가 발생하면, 이를 입력받아 이진 블록 코드들, 예컨대, (20,5) 블록 코드를 사용하여 부호워드를 출력한다.

상기 변조기(12)는 코히런트 변조기(Coherent Modulator) 또는 차등 변조기(Differential Modulator)를 포함한다. 상기 변조기(12)는 상기 이진 채널 부호기(11)에서 출력되는 부호워드를 입력받아, 이에 해당하는 전송 심벌을 코히런트 또는 차등 변조 방식을 사용하여 구한 후 상기 IFFT기(13)로 출력한다. 여기서 상기 변조기는 미리 설정되어 있는 설정 변조 방식 예컨대 QPSK(Quadrature Phase Shift Keying) 방식 또는 DQPSK(Differential Quadrature Phase Shift Keying) 방식 등을 사용할 수 있다.

상기 IFFT기(13)는 상기 변조기(12)로부터 전송 심벌을 입력받아 IFFT를 수행한 후 전송한다. 상기 도 1에서는 종래 기술에 따른 송신기 내부 구조에 대하여 설명하였으며, 다음으로 도 2를 참조하여 종래 기술에 따른 수신기 내부 구조에 대하여 설명하기로 한다.

도 2는 종래 기술에 따른 OFDMA 통신 시스템에서 상향링크 제어정보 수신을 위한 기지국의 수신기 구조를 개략적으로 도시한 도면이다.



상기 도 2를 참조하면, 상기 수신기(20)는 고속 푸리에 변환(Fast Fourier Transform, 이하 'FFT'라 칭하기로 한다)기(23)와, 복조기(Demodulator)(22) 및 이진 채널 복호기(Binary Channel Decoder)(21)를 포함한다.

상기 송신기(10)로부터 전송되는 수신 신호가 입력되면, 상기 FFT기(23)는 상기 수신신호를 입력받아 FFT를 수행하여 수신 심벌을 상기 복조기(22)로 출력한다.

상기 복조기(22)는 상기 송신기(10)에 상응하여 코히런트 복조기(Coherent Demodulator) 또는 차등 복조기(Differential Demodulator) 등으로 구성된다. 상기 복조기(22)는 상기 FFT기(23)에서 출력되는 수신 심벌을 입력받아, 이의 연판정(soft decision) 값을 상기 송신기의 변조 방식에 상응하는 복조 방식 예컨대, 코히런트 복조나 차등 복조 방법을 사용하여 구한다.

상기 이진 채널 복호기(21)는 상기 복조기(22)에서 구한 연판정(soft decision) 값을 입력받아 어떤 부호워드가 전송되었는지를 판단하고 이에 해당하는 데이터 비트를 출력한다.

상술한 바와 같은 구조를 갖는 송신기(10) 및 수신기(20)를 통해 송수신되는 상기 상향링크 고속 피드백 정보는 전체적인 통신 서비스에 있어서 그 양이 많지 않다. 하지만, 상기 상향링크 고속 피드백 정보는 통신 시스템 운용에 매우 중요한 정보이므로 전송에 높은 신뢰성이 보장되어야 한다. 그러나 오버헤드(overhead) 비율을 줄이기 위해 상기 상향링크 고속 피드백 정보를 전송하기 위한 물리적 채널에는 주파수-시간축 자원이 많이 할당되지 않는 것이 보통이다. 따라서 트래픽 채널(traffic channel)처럼 많은 자원이 할당되고, 많은 정보를 보내야 하는 채널들과는 다른 전송 방법이 필요하다.

일반적으로 상향링크 제어정보를 전송하기 위해 이진 채널 부호(binary channel code)와 코히런트 변조(coherent modulation) 또는 차등 변조 (differential modulation)를 결합한 방법을 사용하고 있다.

그러나 적은 주파수-시간축 자원을 사용하여 상기 방법으로 전송할 경우, 오류 확률이 높아져서 통신 시스템 운용의 안정성이 낮아지게 된다. 즉, 파일럿 톤의 개수가 충분한 하향링크의 경우나 상향링크 트래픽 전송의 경우와 달리, 상향링크 제어정보 전송의 경우에는 파일럿 톤의 개수가 부족하게 된다. 따라서 채널추정 성능이 떨어지게 되고, 이에 따라 코히런트 변복조 방법의 성능 역시 떨어지게 된다. 이때, 상기 채널추정 성능만을 생각해 파일럿 톤의 개수를 증가시킬 경우에는 데이터 톤의 개수가 너무 부족하게 된다. 또한 이진 채널 부호와 변조의 분리는 최적화된 성능을 갖지 못하게 하는 원인이 된다. 게다가 안정성을 높이기 위해 많은 주파수-시간축 자원을 상향링크 고속 피드백 정보 전송에 사용할 경우, 오버헤드 비율이 증가하여 통신 시스템의 처리율(throughput)이 감소하게 된다.

또한 일반적인 상향링크 고속 피드백 정보 전송은 1개의 상향링크 부채널이 사용되고, 4비트의 정보를 전송한다. 그러나 상기 4비트의 정보 전송으로는 완전 SNR의 전송에서 충분한 정확성(accuracy)이 보장되지 않고, 밴드별 차분 SNR은 4개의 밴드만을 전송할 수 있는 등 여러 한계를 가지고 있다. 또한 4비트의 정보 전송은 간단한 다른 정보 전송을 위해 약간의 부호워드(Codeword)를 할당하려 해도 부호워드가 16개에 불과하므로 운용의 유연성(flexibility)이 부족하게 된다.

#### 발명이 이루고자 하는 기술적 과제

따라서 본 발명의 목적은 코히런트 변조 방법을 사용하여 상향 링크 고속 피드백 정보를 전송하기 위한 방법 및 장치를 제공함에 있다.

본 발명의 다른 목적은 상향 링크 고속 피드백 정보를 주어진 주파수-시간축 자원을 이용하여 효율적으로 전송하기 위한 방법 및 장치를 제공함에 있다.

본 발명의 또 다른 목적은 통신 시스템에서 제어 정보 전달의 정확성 및 운용의 유연성을 높일 수 있는 5비트 또는 6비트의 상향링크 고속 피드백 정보를 효율적으로 전송하기 위한 방법 및 장치를 제공함에 있다.

본 발명의 또 다른 목적은 M-상 채널 부호와 코히런트 변조 방식을 결합하여, 최적화된 성능을 얻을 수 있는 상향링크 고속 피드백 정보 전송 방법 및 장치를 제공함에 있다.

상기와 같은 목적들을 달성하기 위한 본 발명의 실시예에 따른 방법은, 직교 주파수 분할 다중 접속 방식을 사용하는 통신 시스템에서, 고속 피드백 채널을 이용한 상향링크 고속 피드백 정보를 전송하는 방법에 있어서, 전송하고자 하는 상향링크 고속 피드백 정보를 생성하고, 상기 고속 피드백 정보에 상응하여 모든 가능한 두 부호워드들 간의 임의의 쌍에 대한 최소

해밍 거리가 최대가 되는 부호워드들을 출력하는 과정과, 상기 출력한 부호워드들에 상응하는 전송 심벌들을 직교 변조하고, 상기 직교 변조한 전송 심벌들을 부반송파 묶음에 할당하는 과정과, 상기 부반송파 묶음으로 이루어진 전송 신호를 역고속 푸리에 변환하고, 상기 역고속 푸리에 변환한 전송 신호를 전송하는 과정을 포함한다.

상기와 같은 목적들을 달성하기 위한 본 발명의 실시예에 따른 방법은, 직교 주파수 분할 다중 접속 방식을 사용하는 통신 시스템에서, 고속 피드백 채널에 사용할 상향링크 고속 피드백 정보를 전송하는 위한 방법에 있어서, 상기 상향링크 고속 피드백 정보의 5비트 정보 데이터 비트를 수신하고, 상기 수신한 정보 데이터 비트에 상응하는 부호워드들을 출력하는 과정과, 상기 수신된 정보 데이터 비트의 해당 부호워드에 상응하는 심벌들을 직교 변조하고, 상기 직교 변조된 전송 심벌들을 출력하는 과정과, 상기 변조된 전송 심벌들 및 파일럿 심벌이 할당된 부반송파 묶음들로 이루어진 송신 신호를 역고속 푸리에 변환하고, 상기 역고속 푸리에 변환된 전송 신호를 전송하는 과정을 포함한다.

상기와 같은 목적들을 달성하기 위한 본 발명의 실시예에 따른 방법은, 직교 주파수 분할 다중 접속 방식을 사용하는 통신 시스템에서, 고속 피드백 채널에 사용할 상향링크 고속 피드백 정보를 전송하는 방법에 있어서, 상기 상향링크 고속 피드백 정보의 6비트 정보 데이터 비트를 수신하고, 상기 수신한 정보 데이터 비트에 상응하는 부호워드들을 출력하는 과정과, 상기 수신된 정보 데이터 비트의 해당 부호워드에 상응하는 심벌들을 직교 변조하고, 상기 직교 변조된 전송 심벌들을 출력하는 과정과, 상기 변조된 전송 심벌들 및 파일럿 심벌이 할당된 부반송파 묶음들로 이루어진 송신 신호를 역고속 푸리에 변환하고, 상기 역고속 푸리에 변환된 전송 신호를 전송하는 과정을 포함한다.

상기와 같은 목적들을 달성하기 위한 본 발명의 실시예에 따른 장치는, 직교 주파수 분할 다중 접속 방식을 사용하는 통신 시스템에서, 고속 피드백 채널을 이용한 상향링크 고속 피드백 정보를 전송하는 장치에 있어서, 전송하고자 하는 상향링크 고속 피드백 정보를 생성하고, 상기 고속 피드백 정보에 상응하여 모든 가능한 두 부호워드들 간의 임의의 쌍에 대한 최소 해밍 거리가 최대가 되는 부호워드들을 출력하는 채널 부호기와, 상기 출력한 부호워드들에 상응하는 전송 심벌들을 직교 변조하고, 상기 직교 변조한 전송 심벌들을 부반송파 묶음에 할당하여 출력하는 넌코히런트 변조기와, 상기 부반송파 묶음으로 이루어진 전송 신호를 역고속 푸리에 변환하고, 상기 역고속 푸리에 변환한 전송 신호를 전송하는 역고속 푸리에 변환기를 포함한다.

#### 발명의 구성

이하 본 발명의 바람직한 실시 예를 첨부한 도면을 참조하여 상세히 설명한다. 그리고 본 발명을 설명함에 있어, 관련된 공지 기능 혹은 구성에 대한 구체적인 설명이 본 발명의 요지를 불필요하게 흐릴 수 있다고 판단되는 경우 그 상세한 설명을 생략한다.

제안하는 본 발명에서는 상향링크 제어정보 중의 하나인 상향링크 고속 피드백 정보의 전송에 따른 신뢰성을 높이고, 오버헤드 비율을 줄이기 위해 M-진(M-ary) 채널 부호와 넌코히런트(Noncoherent) 변조 방식을 사용한다. 즉, 본 발명은 상기 M-진 채널 부호와 넌코히런트 변조 방식을 통해 상향링크 고속 피드백 정보를 효율적으로 전송할 수 있는 방법 및 장치에 관한 것이다. 또한, 본 발명에서는 넌코히런트 변복조 방식을 사용함으로써, 주파수-시간축 자원 사용을 줄일 수 있도록 한다. 이를 통해 파일럿 톤을 많이 할당할 수 없는 상향링크 고속 피드백 정보를 효율적으로 전송할 수 있다.

또한, 본 발명에서는 상향링크 고속 피드백(Fast Feedback) 정보 전송에 5비트 또는 6비트의 정보를 전송하는 방법을 제안함으로써, 전달 정보의 정확성 및 운용의 유연성을 높일 수 있도록 한다. 한편, 통신 시스템에서 사용되는 상향링크 고속 피드백 정보량은 매우 작다. 하지만 통신 시스템 운용에 있어 상기 상향링크 고속 피드백 정보는 매우 중요한 정보이다. 따라서 제안하는 본 발명에서는 상기 상향링크 고속 피드백 정보를 전송하기 위해 직교 변조 방식을 적용한다.

이하에서 설명되는 본 발명의 바람직한 실시예들은 직교 주파수 분할 다중 접속(OFDMA: Orthogonal Frequency Division Multiple Access, 이하 'OFDMA'라 칭하기로 한다) 통신 시스템에 적용하여 설명하기로 한다. 또한 본 발명에서는 M-진 위상 변조(PSK: Phase Shift Keying, 이하 'PSK'라 칭하기로 한다) 방식을 이용하여 상향링크 고속 피드백 정보 전송 방법을 설명하기로 한다. 먼저 본 발명의 실시예에 따른 OFDMA 통신 시스템에서 상향링크 고속 피드백 정보를 전송하기 위한 송신기 및 수신기의 구조를 첨부된 도면을 참조하여 설명하기로 한다.

도 3은 본 발명의 실시예에 따른 OFDMA 통신 시스템에서 상향링크 고속 피드백 정보 전송을 위한 송신기 구조를 개략적으로 도시한 도면이다.

상기 도 3을 참조하면, 상기 송신기(100)는, 상향링크 제어 정보 예컨대, 상향링크 고속 피드백 정보의 데이터 비트를 부호화하는 채널 부호기(Channel Encoder)(110)와, 상기 정보 데이터 비트를 넌코히런트(Noncoherent) 방식으로 변조하는 넌코히런트 변조기(Noncoherent Modulator)(120) 및 송신할 신호를 역고속 푸리에 변환(IFFT: Inverse Fast Fourier Transform, 이하 'IFFT'라 칭하기로 한다)하여 전송하는 IFFT기(130)를 포함한다.

상기 채널 부호기(110)는 전송하고자 하는 상향링크 고속 피드백 정보의 데이터 비트가 발생되면, 상기 정보 데이터 비트를 입력받아 이에 해당하는 부호워드(codeword)를 상기 년코히런트 변조기(120)로 출력한다. 여기서 상기 채널 부호기(110)는 입력되는 비트에 따라 이진 채널 부호기 또는 M-진 블록 코드(M-ary Block Code) 등을 사용하는 M-진 채널 부호기를 사용할 수 있다.

상기 년코히런트 변조기(120)는 상기 채널 부호기(110)로부터 입력된 부호워드에 해당하는 전송 심벌을 년코히런트 변조 방식을 사용하여 구한 후 이를 상기 IFFT기(130)로 출력한다. 여기서 상기 년코히런트 변조기(120)는 미리 설정되어 있는 설정 변조 방식, 예컨대 직교 변조(Orthogonal Modulation) 방식 등을 사용할 수 있다. 상기 IFFT기(130)는 상기 년코히런트 변조기(120)로부터 상기 전송 심벌을 입력받아 IFFT를 수행한 후 전송한다. 상기 도 3에서는 본 발명의 실시예에 따른 송신기 내부 구조에 대하여 설명하였으며, 다음으로 도 4를 참조하여 본 발명의 실시예에 따른 수신기 내부 구조에 대하여 설명하기로 한다.

도 4는 본 발명의 실시예에 따른 OFDMA 통신 시스템에서 상향링크 고속 피드백 정보 수신을 위한 수신기 구조를 개략적으로 도시한 도면이다.

#### 삭제

상기 도 4를 참조하면, 상기 수신기(200)는, 시간 영역의 수신 신호를 고속 푸리에 변환(Fast Fourier Transform, 이하 'FFT'라 칭하기로 한다)하여 주파수 영역의 수신 신호로 변환하는 FFT기(230)와, 상기 주파수 영역의 수신 신호를 복조하는 년코히런트 복조기(Noncoherent Demodulator)(220) 및 복조된 수신 심벌에서 상향링크 고속 피드백 정보의 데이터 비트를 복호하는 채널 복호기(Channel Decoder)(210)를 포함한다.

상기 FFT기(230)는 상기 송신기(100)로부터 수신 신호가 입력되면, FFT를 수행하여 수신 심벌을 상기 년코히런트 복조기(220)로 출력한다.

상기 년코히런트 복조기(220)는 상기 FFT기(230)로부터 수신 심벌을 입력받아, 상기 수신한 심벌의 연관정(soft decision) 값을 년코히런트 복조 방법을 사용하여 구한 후 상기 채널 복호기(210)로 출력한다.

상기 채널 복호기(210)는 상기 년코히런트 복조기(220)로부터 상기 연관정(soft decision)값을 입력받아, 상기 송신기(100)로부터 어떤 부호워드가 전송되었는지를 판단하고, 상기 판단 결과에 해당하는 데이터 비트를 출력한다. 여기서 상기 채널 복호기(210)는 입력되는 비트에 따라 이진 채널 복호기 또는 M-진 채널 복호기를 사용할 수 있다.

이상에서는 상기 도 3 및 도 4를 참조하여 본 발명의 실시예에 따른 기능을 수행하기 위한 송수신기의 구조에 대하여 설명하였으며, 이하에서는 본 발명의 실시예에 따른 상기 송수신기를 이용한 상향링크 고속 피드백 정보 송수신 방법에 대하여 설명하기로 한다.

이하에서 설명되는 본 발명의 실시예에 따른 상향링크 고속 피드백 정보 전송은 OFDMA 통신 시스템의 상향링크에서 주파수-시간축 상의 3 x 3 개의 부반송파 묶음 6개가 할당되는 경우의 전송방법을 예를 들어 설명하기로 한다.

#### 삭제

도 5는 본 발명의 실시예에 따른 OFDMA 통신 시스템에서 고속 피드백 채널에 상향링크 고속 피드백 정보 전송을 위해 3 x 3 개의 부반송파 묶음 6개가 할당되는 경우의 주파수-시간축 자원을 도시한 도면이다. 도 6은 본 발명의 실시예에 따른 OFDMA 통신 시스템에서 3 x 3 개의 부반송파 묶음에 할당되는 부호워드들의 일예를 도시한 도면이다. 도 7은 본 발명의 실시예에 따른 OFDMA 통신 시스템에서 3 x 3 개의 부반송파 묶음에 할당되는 부호워드들의 다른 예를 도시한 도면이다. 여기서, 상기 도 5는 M-진 PSK 직교 변조에 사용할 패턴에 따라 상향링크 고속 피드백 정보 전송을 위해 할당되는 주파수-시간축 자원을 나타내며, 이때 정보 데이터 비트의 수는 4 비트이며, M=8 즉 8-상 채널 부호기를 사용하는 경우의 예를 나타낸 것이다. 그러면, 이하에서는 상기 도 5 내지 상기 도 7을 참조하여 고속 피드백 정보로 4비트의 정보 데이터 비트를 전송하는 방법을 설명하고, 그런 다음 상기 도 5와 후술하는 도 8 및 도 9를 참조하여 본 발명의 실시예에서의 고속 피드백 정보로 5비트 및 6비트의 정보 데이터 비트를 전송하는 방법에 대하여 설명하기로 한다.

상기 도 5를 참조하면, 먼저 전송하고자 하는 상향링크 고속 피드백 정보 데이터 비트는 채널 부호기를 통과하여 년코히런트 변조기로 입력된다. 이때, 상기 정보 데이터 비트의 수는 4비트이며, 8-진 채널 부호기를 사용하는 경우를 가정한다. 그

러면 상기 년코히런트 변조기에서는 상기 전송 신호를 직교 변조(Orthogonal Modulation) 방법을 사용하여 변조한다. 이후 상기 년코히런트 변조기를 통해 변조된 변조 심벌들은 IFFT기를 통해 IFFT되어 전송된다. 이하, 하기 도 6을 통해 상기 도 5에 따른 정보 데이터 비트 전송 과정을 보다 구체적으로 설명하기로 한다.

상기 도 6을 참조하면, 상기 도 6은 8-진 채널 부호기에서 출력되는 가능한 16가지의 부호워드들을 도시한 도면이다. 상기 8-진 채널 부호기는, 상기 정보 데이터 비트가 입력되면, 상기 도 6과 같은 가능한 16가지의 부호워드들 중 하나를 년코히런트 변조기로 출력하게 된다. 여기서, 상기 8-진 채널 부호기는 주어진 부호워드의 개수와 길이에 대해, 부호워드 간 최소 해밍 거리(minimum Hamming distance)가 최대가 되도록 설정한다. 상기 해밍 거리라 함은 동일한 비트 수를 가지는 2진 부호 사이에 대응되는 비트 값이 일치하지 않는 것의 개수를 나타낸다. 이때, 상기와 같은 전송 방법에서 부호워드 오류 확률 성능에 주로 영향을 주는 인자인 상기 최소 해밍 거리는 5가 된다. 즉, 상기 16가지 가능한 부호워드에서, 예를 들어 부호워드가 "0"인 경우 부반송과 묶음에 대한 부호워드 A0, A1, A2, A3, A4, A5의 패턴은 "000000"이다. 그리고 부호워드가 "8"인 경우 부반송과 묶음에 대한 부호워드 A0, A1, A2, A3, A4, A5의 패턴은 "012345"가 되어 상기 두 부호워드, 즉 부호워드 "0"과 부호워드 "8" 간의 해밍 거리는 5가 된다. 여기서, 상기 최소 해밍 거리가 5라 함은 모든 가능한 두 부호워드의 쌍에 대해, 상기 두 부호워드 간 해밍 거리가 5 이상임을 나타낸다.

상기 년코히런트 변조기는 상기 8-상 채널 부호기로부터 입력되는 부호워드에 대하여 직교 변조 방법을 사용한다. 즉, 상기 년코히런트 변조기는 상기 직교 변조 방식을 이용하여 상기 8-진 채널 부호기를 통해 부호화된 정보 데이터 비트를 변조한다. 여기서, 상기 변조에 사용할 패턴에 따른 전송 심벌은 상기 도 7에 나타난 바와 같다. 상기 전송 심벌은 직교 벡터들의 집합으로 이루어져 상기 부반송과 묶음에 직접 매핑된다. 상기 직교 변조에 사용할 상기 직교 벡터들은 상기 도 7과 같이, 예컨대 P0, P1, P2 및 P3과 같이 나타내며, 상기 각 직교 변조 심벌들은 QPSK(Quadrature Phase Shift Keying) 변조 심벌들로서, 상기 P0, P1, P2 및 P3은 하기 수학식 1과 같이 구할 수 있다.

$$\begin{aligned} \text{수학식 1} \\ P0 &= \exp\left(j\frac{\pi}{4}\right) \\ P1 &= \exp\left(j\frac{3\pi}{4}\right) \\ P2 &= \exp\left(-j\frac{3\pi}{4}\right) \\ P3 &= \exp\left(-j\frac{\pi}{4}\right) \end{aligned}$$

한편, 3 x 3 개의 부반송과 묶음의 가장자리 8개의 부반송파에는 상기 도 7에 도시된 바와 같은 심벌들을 전송한다. 나머지 가운데 1개의 부반송파에는 파일럿 심벌을 전송한다. 여기서, 상기 파일럿 심벌은 임의로 설정할 수 있다. 그리고 상기 전송되는 심벌들의 값은 첨부된 해당 벡터 인덱스에 해당하는 직교 벡터들로 설정된다.

보다 구체적으로, 전송하고자 하는 4비트의 정보 데이터가 주어지면, 송신기는 상기 도 6에 의하여 부호워드(A0, A1, A2, A3, A4, A5)를 결정한다. 그런 다음, 상기 송신기는, 첫 번째 3 x 3 개의 부반송과 묶음에 A0에 해당하는 직교 벡터를, 두 번째 3 x 3 개의 부반송과 묶음에 A1에 해당하는 직교 벡터를 할당하여 전송한다. 이와 같이, 마지막 여섯 번째 부반송과 묶음에 A5에 해당하는 직교 벡터를 할당하여 상기 도 7의 방법으로 각각 전송한다. 여기서, 상기 도 7을 참조하면, 상기 정보 데이터, 예를 들어 벡터 인덱스 0에 해당하는 전송 심벌 값은 P0, P1, P2, P3, P0, P1, P2, P3이 설정되며, 벡터 인덱스가 4에 해당하는 전송 심벌 값은 P0, P0, P0, P0, P0, P0, P0, P0이 설정되고, 벡터 인덱스 7에 해당하는 전송 심벌 값은 P0, P2, P2, P0, P2, P0, P0, P2가 설정됨을 알 수 있다.

한편, 수신기는 상기 송신기로부터 전송된 전송 신호를 수신하면, FFT기를 통해 수신 신호를 FFT한다. 이어서, 상기 수신기는 년코히런트 복조기에서 3 x 3 개의 부반송과 묶음 6개 각각에 대해 8가지 가능한 직교 벡터에 대한 상관값의 절대값 제곱을 계산한다. 그런 다음, M-진 채널 복조기에서 16가지 모든 가능한 부호워드에 해당하는 직교 벡터의 상관값에 대한 절대값 제곱의 합을 각각 계산한 후, 상기 계산한 값들 중에서 최대값을 갖는 부호워드에 해당하는 정보 데이터 비트를 상기 송신기가 전송한 것으로 결정한다.

일반적인 상향링크 고속 피드백 정보 전송은, 상술한 바와 같이 1개의 상향링크 부채널이 사용되며, 4비트의 정보를 전송한다. 그러나 상기와 같은 4비트로선 완전 SNR의 전송에서 충분한 정확성(accuracy)이 보장되지 않는다. 또한 밴드별 차분 SNR은 4개의 밴드만을 전송할 수 있다. 또한 간단한 다른 정보 전송을 위해 약간의 부호워드를 할당해야하는 경우에도

상기 4비트는 부호워드가 16개에 불과하므로, 운용의 유연성(flexibility)이 부족하게 된다. 따라서, 상기와 같은 문제점을 해결하기 위한 방안으로, 후술하는 본 발명에서와 같이 상향링크 고속 피드백 정보 전송에 5비트 또는 6비트의 정보를 전송하는 방법을 적용함으로써, 전달 정보의 정확성이나 운용의 유연성을 높일 수 있도록 한다.

다음으로 본 발명의 실시예에 따른 상향 링크 고속 피드백 전송 방법을 설명하기로 한다. 여기서 고속 피드백 전송 채널에 주파수-시간축 상의 3 x 3 개의 부반송파 묶음 6개가 할당되는 경우, 할당된 주파수-시간축 자원은 도 5에 도시된 바와 같다. 여기서 정보 데이터의 비트 수는 5비트이며, M=8 즉, 8-진 채널 부호기를 사용한다.

도 8은 본 발명의 실시예에 따른 8-진 채널 부호기에서 출력되는 가능한 32가지의 부호워드들을 도시한 도면이다.

상기 도 8을 참조하면, 상기 8-진 채널 부호기는 상기 정보 데이터 비트가 입력되면, 상기 도 8과 같은 가능한 32가지의 부호워드들 중 하나를 넌코히런트 변조기로 출력하게 된다. 여기서, 상기 8-진 채널 부호기는 주어진 부호워드의 개수와 길이에 대해, 부호워드 간 최소 해밍 거리가 최대가 되도록 설정한다. 이때, 상기 도 8에 도시된 바와 같이, 처음 16개의 부호워드는 상술한 바와 같은 4비트 전송을 위한 도 6의 부호워드와 일치하고, 다음 16개의 부호워드가 추가되었음을 알 수 있다. 이와 같이, 상기 부호워드 개수가 2배로 증가하더라도 부호워드 오류 확률 성능에 주로 영향을 주는 최소 해밍 거리는 여전히 5가 된다. 즉, 상기 32가지 가능한 부호워드에서, 예를 들어 부호워드가 “16”인 경우의 부반송파 묶음에 대한 부호워드 A0, A1, A2, A3, A4, A5의 패턴은 “472516”이고, 부호워드가 “24”인 경우의 부반송파 묶음에 대한 부호워드 A0, A1, A2, A3, A4, A5의 패턴은 “460257”이 되어 상기 두 부호워드 즉, 부호워드 “16”과 부호워드 “24” 간의 해밍 거리는 5가 된다. 여기서, 상기 최소 해밍 거리가 5라 함은 모든 가능한 두 부호워드에 대해, 상기 두 부호워드 간 해밍 거리가 5 이상임을 나타낸다.

상기 넌코히런트 변조기는 상기 8-진 채널 부호기로부터 입력되는 부호워드에 대하여 직교 변조 방법을 사용하며, 이러한 직교 변조에 사용할 직교 벡터들은 상기 도 7에 도시된 바와 같다. 즉, 상기 도 7의 직교 벡터, 예컨대 P0, P1, P2, P3는 QPSK 변조 심벌로서 상기 수학적 식 1과 같이 나타낼 수 있다. 이때, 3 x 3 개의 부반송파 묶음의 가장자리 8개의 부반송파에는 상기 도 7에 도시된 바와 같은 심벌들을 전송한다. 나머지 가운데 1개의 부반송파에는 파일럿 심벌을 전송한다. 여기서, 파일럿 심벌은 임의로 설정할 수 있다.

보다 구체적으로, 먼저 전송하고자 하는 5비트의 정보 데이터가 주어지면, 상기 송신기는 상기 도 8에 의하여 부호워드 (A0, A1, A2, A3, A4, A5)를 결정한다. 그런 다음, 첫 번째 3 x 3 개의 부반송파 묶음 A0에 해당하는 직교 벡터를, 두 번째 3 x 3 개의 부반송파 묶음에 A1에 해당하는 직교 벡터를 할당하여 전송하게 된다. 이렇게 마지막 여섯 번째 3 x 3 개의 부반송파 묶음에는 A5에 해당하는 직교 벡터를 할당하여 상기 도 7에 도시된 방법으로 각각 전송한다.

한편, 수신기에서는 상기 송신기로부터 전송된 전송 신호를 수신하면, FFT기를 통해 수신 신호를 FFT한다. 이어서, 상기 수신기는 넌코히런트 복조기에서 3 x 3 개의 부반송파 묶음 6개 각각에 대해 8가지 가능한 직교 벡터에 대한 상관값의 절대값 제곱을 계산한다. 그런 다음, M-진 채널 복호기에서 32가지 모든 가능한 부호워드에 해당하는 직교 벡터의 상관값에 대한 절대값 제곱의 합을 각각 계산한 후, 상기 계산한 값들 중에서 최대값을 갖는 부호워드에 해당하는 정보 데이터 비트를 상기 송신기가 전송한 것으로 결정한다.

상술한 바와 같은 방법은 정보 데이터의 비트 수가 5비트인 경우의 전송 방법의 일례로 하여 설명하였다. 다음으로 본 발명의 다른 실시예로서, 상기 정보 데이터의 비트 수가 6비트인 경우의 전송 방법에 대하여 설명하기로 한다.

먼저, 본 발명의 실시예에 따른 고속 피드백 정보 채널에 주파수-시간축 상의 자원은 상기 도 5에 도시된 바와 같이, 3 x 3 개의 부반송파 묶음 6개가 할당된다. 여기서 데이터 비트수는 6이며, M=8 즉 8-진 채널 부호기를 사용한다.

도 9는 본 발명의 실시예에 따른 8-진 채널 부호기에서 출력되는 가능한 64가지의 부호워드들을 도시한 도면이다. 상기 도 9를 참조하면, 상기 8-진 채널 부호기는 상기 정보 데이터 비트가 입력되면, 상기 도 9와 같은 가능한 64가지의 부호워드들 중 하나를 넌코히런트 변조기로 출력하게 된다. 여기서, 상기 8-진 채널 부호기는 주어진 부호워드의 개수와 길이에 대해, 부호워드 간 최소 해밍 거리가 최대가 되도록 설정한다. 이때, 상기 도 9에 도시된 바와 같이, 상기 도 9는 4비트 전송을 위한 상기 도 6의 부호워드에 비해 4배가 증가하였음을 알 수 있다. 하지만, 상기와 같이, 부호워드의 개수가 4배로 증가하더라도, 상기 부호워드의 오류확률 성능에 주로 영향을 주는 상기 최소 해밍 거리는 여전히 5가 된다. 즉, 상기 64가지 가능한 부호워드에서, 예를 들어 부호워드가 “32”인 경우의 부반송파 묶음에 대한 부호워드 A0, A1, A2, A3, A4, A5의 패턴은 “675124”이고, 부호워드가 “41”인 경우의 부반송파 묶음에 대한 부호워드 A0, A1, A2, A3, A4, A5의 패턴은 “640352”이 되어 상기 두 부호워드 즉, 부호워드 “32”와 부호워드 “41” 간의 해밍 거리는 5가 된다. 여기서, 상기 최소 해밍 거리가 5라 함은 모든 가능한 두 부호워드에 대해, 상기 두 부호워드 간 해밍 거리가 5 이상임을 나타낸다.

또한, 이러한 방법은 상술한 상기 도 8과 같이 32개의 부호워드만 사용하여 5비트만 전송하는 것도 가능함은 물론이다.

상기 년코히런트 변조기는 상기 8-진 채널 부호기로부터 입력되는 부호워드에 대하여 직교 변조를 사용하며, 이러한 직교 변조에 사용할 직교 벡터들은 상기 도 7에 도시한 바와 같다. 즉, 상기 도 7의 직교 벡터 예컨대, P0, P1, P2, P3은 QPSK 변조 심벌로서 상기 수학식 1과 같이 나타낼 수 있다. 이때, 3 x 3 개의 부반송파 묶음의 가장자리 8개의 부반송파에는 상기 도 7에 도시한 바와 같은 심벌들을 전송한다. 나머지 가운데 1개의 부반송파에는 파일럿 심벌을 전송한다. 여기서, 파일럿 심벌은 임의로 설정할 수 있다.

보다 구체적으로, 먼저 전송하고자 하는 6비트의 정보 데이터가 주어지면, 상기 송신기는 상기 도 9에 도시한 바와 같은 예들의 부호워드들을 통해 상기 부반송파 묶음 6개에 할당하여 전송할 해당 부호워드(A0, A1, A2, A3, A4, A5)를 결정한다. 그런 다음, 첫 번째 3 x 3 개의 부반송파 묶음에 A0에 해당하는 직교 벡터를, 즉 두 번째 3 x 3 개의 부반송파 묶음에 A1에 해당하는 직교 벡터를 할당하여 전송하게 된다. 이렇게 마지막 여섯 번째 3 x 3 개의 부반송파 묶음에는 A5에 해당하는 직교 벡터를 할당하여 상기 도 7에 도시된 방법으로 각각 전송한다.

한편, 수신기에서는 상기 송신기로부터 전송된 전송 신호를 수신하면, FFT기를 통해 수신 신호를 FFT한다. 이어서, 상기 수신기는 년코히런트 복조기에서 3 x 3 개의 부반송파 묶음 6개 각각에 대해 8가지 가능한 직교 벡터에 대한 상관값의 절대값 제곱을 계산한다. 그런 다음, M-진 채널 복조기에서 64가지 모든 가능한 부호워드에 해당하는 직교 벡터의 상관값에 대한 절대값 제곱의 합을 각각 계산한 후, 상기 계산한 값들 중에서 최대값을 갖는 부호워드에 해당하는 정보 데이터 비트를 상기 송신기가 전송한 것으로 결정한다.

한편, 본 발명의 상세한 설명에서는 구체적인 실시 예에 관하여 설명하였으나, 본 발명의 범위에서 벗어나지 않는 한도 내에서 여러 가지 변형이 가능함은 물론이다. 그러므로 본 발명의 범위는 설명된 실시 예에 국한되어 정해져서는 안되며 후술하는 발명청구의 범위뿐만 아니라 이 발명청구의 범위와 균등한 것들에 의해 정해져야 한다.

#### 발명의 효과

상술한 바와 같이 본 발명은, 상향 링크 고속 피드백 정보를 주어진 주파수-시간축 자원을 이용하여 전송 하는 경우, 전송 하는 정보 데이터의 비트를 5비트 또는 6비트로 증가함으로써 보다 정확한 정보를 전달할 수 있고, 보다 안정적으로 시스템을 운영할 수 있는 효과가 있다.

#### 도면의 간단한 설명

도 1은 종래 기술에 따른 직교 주파수 분할 다중 접속 통신 시스템에서 상향링크 고속 피드백 정보 전송을 위한 송신기 구조를 개략적으로 도시한 도면.

도 2는 종래 기술에 따른 직교 주파수 분할 다중 접속 통신 시스템에서 상향링크 고속 피드백 정보 수신을 위한 수신기 구조를 개략적으로 도시한 도면.

도 3은 본 발명의 실시예에 따른 직교 주파수 분할 다중 접속 통신 시스템에서 상향링크 고속 피드백 정보 전송을 위한 송신기 구조를 개략적으로 도시한 도면.

도 4는 본 발명의 실시예에 따른 직교 주파수 분할 다중 접속 통신 시스템에서 상향링크 고속 피드백 정보 수신을 위한 수신기 구조를 개략적으로 도시한 도면.

도 5는 본 발명의 실시예에 따른 직교 주파수 분할 다중 접속 통신 시스템에서 상향링크 고속 피드백 정보 전송을 위해 할당되는 주파수-시간축 자원을 도시한 도면.

도 6은 본 발명의 실시예에 따른 직교 주파수 분할 다중 접속 통신 시스템에서 16가지의 부호워드들을 도시한 도면.

도 7은 본 발명의 실시예에 따른 년코히런트 변조기에서 직교 변조에 사용할 직교 벡터들을 도시한 도면.

도 8은 본 발명의 실시예에 따른 8-상 채널 부호기에서 출력되는 32가지의 부호워드들을 도시한 도면.

도 9는 본 발명의 실시예에 따른 8-상 채널 부호기에서 출력되는 64가지의 부호워드들을 도시한 도면.

도면

도면1

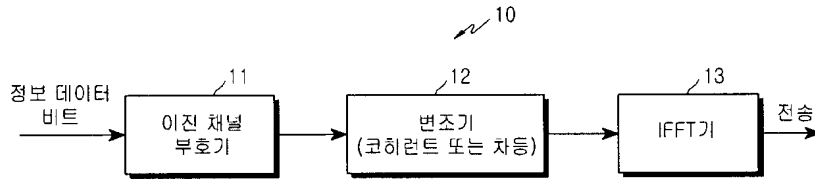

도면2

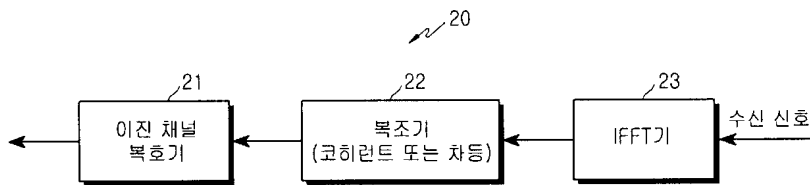

도면3

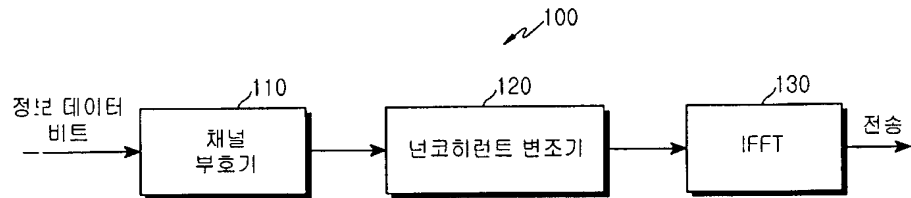

도면4

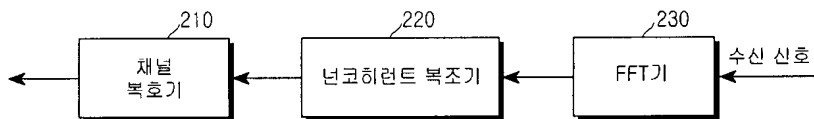





도면6

부호워드	0	1	2	3	4	5	6	7	8	9	10	11	12	13	14	15
A0	0	1	2	3	4	5	6	7	0	1	2	3	4	5	6	7
A1	0	1	2	3	4	5	6	7	1	2	3	4	5	6	7	0
A2	0	1	2	3	4	5	6	7	2	3	4	5	6	7	0	1
A3	0	1	2	3	4	5	6	7	3	4	5	6	7	0	1	2
A4	0	1	2	3	4	5	6	7	4	5	6	7	0	1	2	3
A5	0	1	2	3	4	5	6	7	5	6	7	0	1	2	3	4

도면7

벡터 인덱스	부호워드 당 부반송파 변조
	부반송파 0, 부반송파 1, . . . 부반송파 7
0	P0, P1, P2, P3, P0, P1, P2, P3
1	P0, P3, P2, P1, P0, P3, P2, P1
2	P0, P0, P1, P1, P2, P2, P3, P3
3	P0, P0, P3, P3, P2, P2, P1, P1
4	P0, P0, P0, P0, P0, P0, P0, P0
5	P0, P2, P0, P2, P0, P2, P0, P2
6	P0, P2, P0, P2, P2, P0, P2, P0
7	P0, P2, P2, P0, P2, P0, P0, P2

도면 8

부호워드	0	1	2	3	4	5	6	7	8	9	10	11	12	13	14	15
A0	0	1	2	3	4	5	6	7	0	1	2	3	4	5	6	7
A1	0	1	2	3	4	5	6	7	1	2	3	4	5	6	7	0
A2	0	1	2	3	4	5	6	7	2	3	4	5	6	7	0	1
A3	0	1	2	3	4	5	6	7	3	4	5	6	7	0	1	2
A4	0	1	2	3	4	5	6	7	4	5	6	7	0	1	2	3
A5	0	1	2	3	4	5	6	7	5	6	7	0	1	2	3	4
부호워드	16	17	18	19	20	21	22	23	24	25	26	27	28	29	30	31
A0	4	5	6	7	0	1	2	3	4	5	6	7	0	1	2	3
A1	7	0	1	2	3	4	5	6	6	7	0	1	2	3	4	5
A2	2	3	4	5	6	7	0	1	0	1	2	3	4	5	6	7
A3	5	6	7	0	1	2	3	4	2	3	4	5	6	7	0	1
A4	1	2	3	4	5	6	7	0	5	6	7	0	1	2	3	4
A5	6	7	0	1	2	3	4	5	7	0	1	2	3	4	5	6

도면9

부호워드	0	1	2	3	4	5	6	7	8	9	10	11	12	13	14	15
A0	0	1	2	3	4	5	6	7	2	3	0	1	6	7	4	5
A1	0	1	2	3	4	5	6	7	4	5	6	7	0	1	2	3
A2	0	1	2	3	4	5	6	7	3	2	1	0	7	6	5	4
A3	0	1	2	3	4	5	6	7	6	7	4	5	2	3	0	1
A4	0	1	2	3	4	5	6	7	7	6	5	4	3	2	1	0
A5	0	1	2	3	4	5	6	7	5	4	7	6	1	0	3	2
부호워드	16	17	18	19	20	21	22	23	24	25	26	27	28	29	30	31
A0	4	5	6	7	0	1	2	3	3	2	1	0	7	6	5	4
A1	3	2	1	0	7	6	5	4	6	7	4	5	2	3	0	1
A2	6	7	4	5	2	3	0	1	7	6	5	4	3	2	1	0
A3	7	6	5	4	3	2	1	0	5	4	7	6	1	0	3	2
A4	5	4	7	6	1	0	3	2	1	0	3	2	5	4	7	6
A5	1	0	3	2	5	4	7	6	2	3	0	1	6	7	4	5
부호워드	32	33	34	35	36	37	38	39	40	41	42	43	44	45	46	47
A0	6	7	4	5	2	3	0	1	7	6	5	4	3	2	1	0
A1	7	6	5	4	3	2	1	0	5	4	7	6	1	0	3	2
A2	5	4	7	6	1	0	3	2	1	0	3	2	5	4	7	6
A3	1	0	3	2	5	4	7	6	2	3	0	1	6	7	4	5
A4	2	3	0	1	6	7	4	5	4	5	6	7	0	1	2	3
A5	4	5	6	7	0	1	2	3	3	2	1	0	7	6	5	4
부호워드	48	49	50	51	52	53	54	55	56	57	58	59	60	61	62	63
A0	5	4	7	6	1	0	3	2	1	0	3	2	5	4	7	6
A1	1	0	3	2	5	4	7	6	2	3	0	1	6	7	4	5
A2	2	3	0	1	6	7	4	5	4	5	6	7	0	1	2	3
A3	4	5	6	7	0	1	2	3	3	2	1	0	7	6	5	4
A4	3	2	1	0	7	6	5	4	6	7	4	5	2	3	0	1
A5	6	7	4	5	2	3	0	1	7	6	5	4	3	2	1	0

도면9a

삭제

도면9b

삭제

Please Click here to view the drawing

Korean FullDoc.

English Fulltext

(19)  KOREAN INTELLECTUAL PROPERTY OFFICE

KOREAN PATENT ABSTRACTS

(11)Publication number: **1020040056976 A**  
 (43)Date of publication of application: **01.07.2004**

(21)Application number: **1020020083727**  
 (22)Date of filing: **24.12.2002**  
 (30)Priority: ..

(71)Applicant: **ELECTRONICS AND TELECOMMUNICATIONS RESEARCH INSTITUTE**  
 (72)Inventor: **JANG, IL SUN  
 KIM, HYEON JAE**

(51)Int. Cl **H04L 27/26**

(54) APPARATUS AND METHOD FOR DETERMINING CHANNEL INFORMATION IN OFDM SYSTEM AND RECORDING MEDIUM FOR STORING PROGRAM

(57) Abstract:

PURPOSE: An apparatus and a method for determining channel information in an OFDM system and a recording medium for storing a program are provided to improve the adaptive modulation/code performance by feeding back only the channel information of a corresponding sub-carrier. CONSTITUTION: Information of sub-carrier groups is received from a base station(S1). The best sub-carrier group is selected from the sub-carrier groups by considering the channel environment(S2). A minimum modulation/coding scheme is obtained from modulation/coding schemes(S3). A channel variation level and a transmission bit within each sub-carrier group are obtained according to each modulation/code scheme by increasing gradually the modulation/code scheme level(S4-S8). A representative value is determined by using the modulation/code scheme and the channel variation level(S9,S10). The information related to the modulation/code scheme and the channel change level for the corresponding sub-carrier is fed back to the base station (S11).

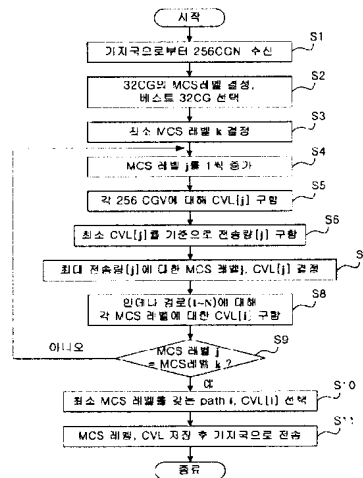

copyright KIPO 2004

Legal Status

Date of request for an examination (20021224)  
 Notification date of refusal decision ( )  
 Final disposal of an application (registration)  
 Date of final disposal of an application (20041027)

(19)대한민국특허청(KR)  
(12) 등록특허공보(B1)

(51) Int. Cl.<sup>7</sup>  
H04L 27/26

(45) 공고일자 2004년11월09일  
(11) 등록번호 10-0456477  
(24) 등록일자 2004년11월01일

(21) 출원번호 10-2002-0083727 (65) 공개번호 10-2004-0056976  
(22) 출원일자 2002년12월24일 (43) 공개일자 2004년07월01일

(73) 특허권자 한국전자통신연구원  
대전 유성구 가정동 161번지

(72) 발명자 김현재  
인천광역시 부평구 부개동 주공아파트 506동 1904호  
장일순  
대전광역시 유성구 전민동 청구나래아파트 110동 802호

(74) 대리인 유미특허법인

심사관 : 오상관

(54) 직교주파수 분할다중에서의 채널 정보 결정 시스템 및 방법, 그 프로그램이 저장된 기록매체

요약

본 발명은 직교주파수 분할다중에서의 채널 정보 결정 시스템 및 방법, 그 프로그램이 저장된 기록매체에 관한 것으로서, 이를 위하여 본 발명은 적응형 변조/코딩 기법을 적용하는 경우에, 각 안테나 경로에 대해 최대 전송량을 갖는 부반송파 그룹간의 채널변화율과 변조/코드비율의 조합을 결정함으로써 단말기에서 해당 부반송파에 대한 채널 정보만을 피드백하므로 기존에 비해 오버헤드의 증가없이 적응 변조/코드 성능을 향상시킬 수 있고, 최대 전송량을 갖는 변조/코드 비율과 채널 변화율의 조합을 선택하므로 시스템 성능을 향상시킬 수 있고, 또한 각 안테나 경로에 대해 채널 정보를 피드백하지 않고 모든 안테나 경로를 고려한 변조/코드 비율과 채널 변화율을 결정하므로 많은 양의 피드백 정보를 요구하지 않는다

대표도

도 1

색인어

MIMO-OFDM, FDD, 적응형 변조/코딩, 채널변화율(CVL), 변조/코드 비율(MCS)

명세서

도면의 간단한 설명

도 1은 본 발명에 따른 실시예의 직교주파수 분할다중에서의 채널 정보 결정 시스템의 구성을 도시한 것이다.  
도 2는 본 발명에 따른 실시예의 직교주파수 분할 다중에서의 채널 정보 결정 시스템에서 사용되는 용어를 설명하기 위한 도면이다.

도 3은 본 발명에 따른 실시예의 직교주파수 분할다중에서의 채널 정보 결정 방법의 순서도를 도시한 것이다.  
 도 4는 각 안테나 경로에 대한 MCS 레벨 결정 알고리즘의 동작 예시도를 도시한 것이다.  
 도 5는 본 발명에 따른 실시예의 직교주파수 분할다중에서의 채널 정보 결정 시스템을 MIMO(Multiple Input Multiple Output)-직교주파수 분할다중 시스템에 적용한 예를 도시한 것이다.

## 발명의 상세한 설명

### 발명의 목적

#### 발명이 속하는 기술 및 그 분야의 종래기술

본 발명은 직교주파수 분할다중에서의 채널 정보 결정 시스템 및 방법, 그 프로그램이 저장된 기록매체에 관한 것으로, 보다 상세하게는 피드백 정보의 증가없이 모든 안테나 경로를 고려하여 최대 전송량을 갖는 부반송파 그룹의 유사 정도와 변조/코드 비율의 조합을 결정하는 직교주파수 분할다중에서의 채널 정보 결정 시스템 및 방법, 그 프로그램이 저장된 기록매체에 관한 것이다.

무선 채널 환경에서 사용되는 각각의 단말기는 서로 다른 무선 채널 환경을 가지며 각 단말기의 부반송파마다 서로 다른 채널 환경을 가지게 된다.

일반적으로, OFDM(Orthogonal Frequency Division Multiplexing) 시스템은 사용자별 스펙트럼 효율을 증가시키기 위해 각 단말기의 부반송파마다 채널 환경에 적합한 코딩 방식 및 변조 방식(AMC)을 사용한다.

즉, 무선 환경이 양호한 부반송파에 대해서는 동시에 여러 비트를 전송할 수 있는 부호율이 낮은 채널 부호화기와 고차 변조 방식을 선택한다. 그런데, 무선 환경이 비교적 양호하지 못한 부반송파에 대해서는 부호율이 높은 채널 부호화기와 BPSK(Binary Phase Shift Keying) 변조 방식과 같은 낮은 차수의 변조 방식을 선택한다.

종래 기술에 따른 실시예의 OFDM 시스템을 위한 AMC(Adaptive Modulation and Coding) 알고리즘을 살펴보면 다음과 같다.

기지국의 패킷 스케줄러가 최상의 성능으로 동작하기 위해 각 단말기의 하향링크에 대한 모든 부반송파 채널 정보를 필요로 한다.

일 실시예로, DMM(Discrete Multitone Modulation) 시스템에서 최적 이산 로딩(discrete loading) 알고리즘은 모든 부반송파의 채널 정보를 피드백하고, 각 부반송파에 적절한 변조방식을 선택하여 최적 조건(Optimum) 성능을 갖는 것이다.

그러나, DMM 시스템에서 최적 이산 로딩 알고리즘은 상향 링크의 한정된 제어 채널에 모든 부반송파의 채널 정보를 피드백하는 것이 불가능하다는 문제점이 있다.

위의 문제점으로 인해, 다른 실시예로, OFDM 시스템에서 적응 변조를 위한 알고리즘은 적은 정보량에 많은 채널 정보를 포함하여 피드백하기 위해 부채널 정보를 블록 단위로 적용한 것이다.

OFDM 시스템에서 적응 변조를 위한 알고리즘은 HIPERLAN/2(High Performance Radio Local Area Network 2) 시스템을 위한 블록 단위의 채널 정보를 이용하는 SBLA(Simple Blockwise Loading Algorithm) 등이 해당된다.

그런데, 블록 단위로 부채널에 대한 채널 정보를 전달하는 경우에, 블록당 부채널 수가 많아지면 다중 채널 환경에서의 디프 페이딩(deep fading) 현상에 의해 시스템 성능에 악영향을 미치는 문제점이 있다.

#### 발명이 이루고자 하는 기술적 과제

본 발명은 위의 문제점을 해결하기 위한 것으로, 본 발명의 목적은 단말기에서 기지국으로 피드백되는 정보의 증가 없이 다중 안테나 경로를 고려한 변조/코드 비율 및 채널 변화율을 결정하는 직교주파수 분할다중에서의 채널 정보 결정 시스템 및 방법, 그 프로그램이 저장된 기록매체를 제공하는 것이다.

### 발명의 구성 및 작용

상기한 바와 같은 목적을 실현하기 위한 본 발명에 따른 직교주파수 분할다중에서의 채널 정보 결정 방법의 특징은, a) 기지국으로부터 전송되는 부반송파 그룹의 정보를 수신하고, 상기 부반송파 그룹들 중에서 채널 환경을 고려하여 최상의 부반송파 그룹을 선택하는 단계; b) 상기 a) 단계에서 선택한 최상의 부반송파 그룹에서 변조/코드 비율을 구한 후에 상기 변조/코드 비율 중에서 최소 변조/코드 비율을 결정하는 단계; c) 상기 b) 단계에서 결정한 최소 변조/코드 비율까지 변조/코드 비율의 레벨을 증가시키면서 각 변조/코드 비율마다 모든 안테나 경로에 대해 각 부반송파 그룹 내 채널 변화율과 전송량을 구하는 단계; 및 d) 상기 c) 단계를 통해 각 안테나 경로에 대해 변조/코드 비율과 채널 변화율을 이용하여 대표 값을 결정하고, 해당 부반송파에 대한 상기 변조/코드 비율과 채널 변화 레벨 정보를 기지국으로 피드백하는 단계를 포함한다.

상기 b) 단계에서 변조/코드 비율은 부반송파별 수신 신호대잡음비에 맞추어 결정되는 변조방식 및 부호율의 조합을 나타내고, 상기 c) 단계에서 채널 변화율은 인접 부반송파 그룹들 간의 채널 유사 정도를 나타낸다.

상기 c) 단계는, 가) 제1 안테나 경로에 대해 상기 변조/코드 비율( $j=1\sim K$ )을 상기 최소 변조/코드 비율( $K$ )까지 증가시키며 각 변조/코드 비율마다 부반송파 그룹 내 유사한 변조/코드 비율을 갖는 채널 변화율을 구하는 단계; 나) 상기 나) 단계에서 구한 부반송파 그룹 중 최소 채널 변화율을 기준으로 해당 변조/코드 비율에 대한 전송량을 계산하는 단계; 다) 상기 나) 단계에서 구한 전송량을 각 변조/코드 비율마다 비교하여 최대 전송량을 갖는 변조/코드 비율과 채널 변화율을 결정하는 단계; 및 라) 다른 안테나 경로에 대해 상기 제1 안테나 경로의 최상의 부반송파 그룹을 기준으로 각 변조/코드 비율마다 채널 변화율을 구하는 단계를 포함한다.

상기 d) 단계에서 안테나 경로에 대해 대표 값을 결정하는 단계는, 상기 특정 안테나 경로에 대해 각 변조/코드 비율과 채널 변화율의 조합에 있어 최대 전송량을 갖는 변조/코드 비율과 채널 변화율을 해당 안테나 경로에 대한 대표 값으로 사용한다.

상기 d) 단계에서 안테나 경로에 대해 대표 값을 결정하는 단계는, 상기 모든 안테나 경로 중에서 최소 변조/코드 비율과 채널 변화율을 기준으로 모든 안테나 경로에 대한 대표 값으로 사용한다.

상기 d) 단계에서 안테나 경로에 대해 대표 값이 결정되면, 상기 단말기는 변조/코드 비율과 채널 변화율 정보를 이용하여 기지국으로부터의 송신 데이터를 부반송파별로 복조하고, 상기 부반송파별 복조된 데이터 중에서 자신에게 할당된 부반송파 그룹의 트래픽만을 선별하는 단계를 포함한다.

상기 d) 단계에서 안테나 경로에 대해 대표 값이 결정되면, 상기 단말기는 상기 변조/코드 비율과 채널 변화율을 저장하고, 상기 저장된 변조/코드 비율과 채널 변화율 정보를 기지국으로 전송되는 다음 송신 데이터의 복조시 사용한다.

상기 d) 단계에서 피드백되는 정보를 기지국이 수신하면, 상기 기지국은 상기 단말기로부터의 피드백 정보를 이용하여 각 단말기마다 적정 부반송파가 할당되도록 스케줄링 한다.

직교주파수 분할다중에서의 채널 정보 결정 시스템의 특징은, 기지국으로부터 부반송파별 채널 정보를 획득하여 그 채널 정보에 따라 모든 안테나 경로에 대해 변조/코드 비율을 결정하고, 상기 변조/코드 비율 정보를 토대로 송신 데이터의 적응 복조를 수행하여 각 단말기별 할당된 부반송파 그룹의 트래픽 데이터만을 선별하는 다수의 수신장치; 및 상기 수신장치로부터 해당 부반송파에 대한 변조/코드 비율 정보를 피드백받아 이를 이용하여 각 사용자에게 부반송파를 정당하게 배분하고, 각 사용자에게 할당된 부반송파 그룹별 적응 변조된 송신 데이터를 상기 수신장치로 전송하는 송신장치를 포함한다.

상기 변조/코드 비율은 부반송파별 수신 신호대잡음비에 맞추어 결정되는 변조방식 및 부호율의 조합, 상기 채널 변화율은 인근 부반송파 그룹들 간의 채널 유사 정도를 각각 나타낸다.

상기 수신 장치는 각 안테나 경로에 대해 변조/코드 비율과 채널 변화율의 조합에 있어 최대 전송량을 갖는 조합을 해당 안테나 경로에 대한 대표 값으로 결정한다. 상기 수신장치는 각 안테나 경로에 대해 최소 변조/코드 비율과 채널 변화율을 기준으로 모든 안테나 경로에 대한 대표 값을 결정한다.

상기 수신 장치는,

상기 송신장치로부터 전송되는 송신 데이터의 파일럿(Pilot) 신호로부터 각 부반송파 그룹별 채널 상대 정보를 획득하고, 상기 채널 상대 정보에 따라 변조/코드 비율을 결정하는 채널 추정부; 및 상기 채널 추정부에서 결정된 변조/코드 비율 정보를 저장하고, 상기 저장된 변조/코드 비율 정보를 다음 송신 데이터 복조시 사용하도록 MCS 정보 저장부; 상기 MCS 정보 저장부에 저장되어 있는 변조/코드 비율 정보를 이용하여 상기 송신장치로부터 전송되는 송신 데이터를 적응 복조하는 적응 복조부; 및 상기 적응 복조부에서 복조된 데이터 중에서 부반송파 할당 정보를 이용하여 각 사용자별 할당된 부반송파 그룹의 트래픽 데이터만을 선별하는 부반송파 선별부를 포함한다.

상기 송신 장치는

상기 수신 장치마다 피드백되는 피드백정보를 각 사용자별 저장하는 피드백 정보 집합부; 상기 피드백 정보 집합부의 피드백 정보를 이용하여 패킷 스케줄링을 수행하여 각 사용자에게 할당할 부반송파 정보와 적응 변조 정보를 생성 출력시키는 패킷 스케줄러; 상기 패킷 스케줄러의 부반송파 정보를 전달받아 각 사용자에게 부반송파를 적절하게 나누어주는 부반송파 할당부; 및 상기 부반송파 할당부에서 각 사용자별 할당된 부반송파에 실리는 데이터를 상기 패킷 스케줄러의 적응 변조 정보에 맞추어 변조하는 적응 변조부를 포함한다.

직교주파수 분할다중에서의 채널 정보 결정 방법을 구현한 프로그램이 저장된 기록매체의 특징은, 기지국으로부터 전송되는 부반송파 그룹의 정보를 수신하고, 상기 부반송파 그룹들 중에서 채널 환경을 고려하여 최상의 부반송파 그룹을 선택하는 제1 기능; 상기 최상의 부반송파 그룹에서 변조/코드 비율을 구한 후에 상기 변조/코드 비율 중에서 최소 변조/코드 비율을 결정하는 제2 기능; 상기 최소 변조/코드 비율까지 변조/코드 비율의 레벨을 증가시키면서 각 변조/코드 비율마다 모든 안테나 경로에 대해 각 부반송파 그룹 내 채널 변화율과 전송량을 구하는 제3 기능; 및 상기 각 안테나 경로에 대해 변조/코드 비율과 채널 변화율을 이용하여 대표 값을 결정하고, 해당 부반송파에 대한 상기 변조/코드 비율과 채널 변화 레벨 정보를 기지국으로 피드백하는 제4 기능을 포함한다.

이하 첨부된 도면을 참조하여 본 발명이 속하는 기술분야에서 통상의 지식을 가진 자가 본 발명을 용이하게 실시할 수 있는 바람직한 실시예를 상세히 설명하면 다음과 같다.

도 1은 본 발명에 따른 실시예의 직교주파수 분할다중에서의 채널 정보 결정 시스템의 구성을 도시한 것이다.

도 1에 도시된 바와 같이, 본 발명에 따른 실시예의 시스템은 크게 송신장치(100)와 수신장치(200)로 구분될 수 있다. 송신장치(100)는 기지국에서 송신 데이터를 부반송파 그룹별 분산하여 전송하고, 수신장치(200)는 사용자 k의 단말기로서 자신에게 할당된 부반송파 그룹의 송신 데이터만을 수신한다.

먼저 송신장치(100)의 구성을 살펴보면, 피드백정보 집합부(110)는 각 수신장치(200), 즉 단말기로부터 피드백되는 무선 환경 채널에 대한 정보를 수신하여 부반송파 그룹별 정보를 패킷 스케줄러(120)로 전송한다.

그러면, 패킷 스케줄러(120)는 피드백정보 집합부(110)에서 전달되는 부반송파 그룹별 정보를 이용하여 시스템 처리율이 향상되도록 각 사용자에게 부반송파를 적절하게 나누어주는 스케줄링 동작을 수행한다.

부반송파 할당부(130)는 패킷 스케줄러(120)에 의해 사용자의 트래픽에 부반 송파 그룹을 적절하게 할당하고, 적응 변조부(140)는 패킷 스케줄러(120)로부터 전달되는 적응 변조 방식에 맞추어 QPSK, 16-QAM, 64QAM으로의 변조를 수행한다.

이렇게 변조된 데이터는 역 푸리에 변환부(IFFT, 150)에서 여러 개의 부반송파로 데이터 전송을 위한 역 푸리에 변환되고, 보호구간 삽입부(160)에서 다중경로 무선 환경 채널에서 심볼간의 간섭을 피하기 위해 보호구간(Guard interval)이 삽입된다.

그 후, 보호구간 삽입부(160)에서 보호구간이 삽입된 데이터는 병렬/직렬 변환부(P/S, 170), 다중화부(MUX, 180), 디지털/아날로그 변환부(DAC, 190), 및 캐리어 변조부(195)를 통해 채널 추정 또는 단말기 수신단에서 동기를 위해 사용되는 파일럿(Pilot) 신호와 함께 RF 변조되어 단말기로 전송된다.

다음, 수신장치(200)의 구성을 살펴보면, 캐리어 복조부(210), 아날로그/디지털 변환부(ADC, 215), 역 다중화부(DEMUX, 220), 및 직렬/병렬 변환부(S/P, 225)는 송신장치(100), 즉 기지국에서 전송되는 RF 신호를 기저대역 신호로 변환하고, 보호구간 제거부(230)에서 기저대역 신호에 삽입되어 있는 보호 구간을 제거한다.

보호구간 제거부(230)를 통해 보호 구간이 제거된 신호는 푸리에 변환부(FFT, 240)에서 푸리에 변환을 한 후에 적응 복조부(250)에서 각 부반송파별 복조를 수행하게 된다.

채널 추정부(260)는 파일럿 신호로부터 각 부반송파 그룹별 채널 상대 정보를 획득하여 얻어진 채널 정보에 따라 MCS(Modulation and Coding Scheme)을 결정하고, 이렇게 결정된 MCS 정보는 MCS 정보 저장부(275)에 저장되고, 아울러 상향 링크 제어 채널을 통해 기지국의 피드백 정보 집합부(110)로 전달된다.

MCS 정보 저장부(275)에 저장된 MCS 정보는 적응 복조부(250)가 단말기에서 적응 변조된 신호를 복조하기 위해 기지국에서 어떤 변조 방식을 사용하였는지를 알 수 있도록 한다.

따라서, 적응 복조부(250)는 각 부반송파별 복조시 MCS 저장부(275)로부터 전달되는 MCS 정보를 이용하여 복조를 수행한다.

적응 복조부(250)에서 복조된 데이터는 부반송파 선별부(290)에서 각 단말기로 할당된 부반송파 그룹의 트래픽 데이터만을 선별하는데, 역 다중화부(220)로부터 부반송파 할당 정보를 추출하여 이를 부반송파 선별부(290)로 데이터 선별 정보를 제공한다.

이와 같이 구성되는 본 발명에 따른 실시예의 직교주파수 분할다중에서의 채널 정보 결정 시스템의 동작을 첨부된 도면을 참고하여 설명하면 다음과 같다.

도 2는 본 발명에 따른 실시예의 직교주파수 분할 다중에서의 채널 정보 결정 시스템에서 사용되는 용어를 설명하기 위한 도면이다.

도 2에서, MCS 레벨(level)은 부반송파별 수신 신호대잡음비(SNR, Signal to Noise Ratio)에 맞추어 결정되는 변조 방식 및 부호율의 조합을 나타낸다.

CG(Cluster Group)은 부반송파를 묶은 기본 단위를 의미하는 것이고, 이때 여러 개의 부반송파를 묶어놓은 것이 클러스터(Cluster)라고 한다.

예를 들어, 클러스터가 32개의 부반송파로 구성되면 32CG이고, 256개의 부반송파로 구성되면 256CG이다.

256CGN(CG Number)은 호 설정시 단말기가 기지국으로부터 할당받은 4개의 256CG의 번호이며, 베스트 32CG는 각 4개의 256CGN에서 가장 MCS 레벨이 높은 값을 갖는 32CG의 위치정보를 나타낸다.(0~7)

채널 변화율(Channel Variation Level, CVL)은 인근 CG들 간 채널 유사정도를 나타낸다.(32CG~256CG) 클러스터 전송 레벨(Cluster Transmit Level, CTL)은 단말기로부터 전달된 CVL보다 작은 레벨의 값 중에서 기지국의 패킷 스케줄러(120)가 단말기로 데이터를 전달할 때 사용하는 CG를 나타낸다.

트래픽 할당 플래그(Traffic Allocation Flag, TAF)는 4개의 256CGN 중 실제 데이터가 할당된 256CG를 표시한다.

예를 들어, 단말기로부터 추천된 CVL이 기지국의 송신 데이터보다 많은 클러스터를 포함하는 경우에, 기지국은 하나의 단말기에 필요 이상의 클러스터 할당을 방지하기 위해 추천된 CVL 값만을 선택하지 않고 CVL보다 작은 값을 선택하여 데이터를 전송할 수 있다.

도 3은 본 발명에 따른 실시예의 직교주파수 분할다중에서의 채널 정보 결정 방법의 순서도를 도시한 것이다.

도 3에 도시된 바와 같이, 단말기는 데이터 전송을 위해 기지국으로부터 전송되는 호 설정시 4개의 256CGN을 수신한다.(S1) 따라서, 단말기는 256CGN에 해당되는 부반송파를 통하여 기지국으로부터 데이터를 전달받을 수 있고, 해당 부반송파에 대한 채널 정보만을 기지국으로 전송한다.

각 안테나 경로(1~N)에 대해 단말기는 32개의 부채널 중 최소 값을 기준으로 32CG의 MCS 레벨을 정한 후, 각 256CGN에서 가장 좋은 채널 환경을 갖는 베스트 32CG를 선택한다.(S2)

단말기는 베스트 32CG 중에서 최소 MCS 레벨을 K로 결정하고(S3), MCS 레벨  $j(j=1\sim k)$ 을 1씩 증가시키며 각 MCS 레벨마다 256CGN 내 유사한 MCS 레벨을 갖는 채널 변화율(CVL[j])을 구한다.(S4, S5)

단말기는 4개의 256CGN 중 최소 CVL[j]을 기준으로 해당 MCS 레벨 j에 대한 전송량(Total\_transmittable\_bit)[j]을 계산한다.(S6) 그 후, 단말기는 K개의 MCS 레벨에 대해 전송량을 비교하여 최대 전송량[j]을 갖는 MCS 레벨 j과 CVL[j] 값을 결정한다.(S7)

모든 안테나 경로에 대해 베스트 32CG를 기준으로 각 MCS 레벨에 대한 CVL[i]을 구한 후 저장한다.(S8) 단말기는 MCS 레벨 j이 K가 되면 MCS 레벨을 K로 결정한 후에 N개의 안테나 경로 중에서 최소 MCS 레벨을 갖는 안테나 경로(path i)와 CVL[i]을 선택한다.(S9, S10)

단말기는 위에서 구한 MCS 레벨과 CVL을 저장하여 하향 링크 제어정보가 축소되도록 하고, 이 MCS 레벨과 CVL에 대한 피드백 정보를 정해진 채널 구조에 넣어 상향 링크 제어 채널을 통해 기지국으로 전달한다.(S11)



따라서, 기지국의 피드백정보 집합부(110)는 각 단말기의 피드백정보를 패킷 스케줄러(120)로 전달하고, 패킷 스케줄러는 피드백 정보 내의 부반송파 그룹별 정보를 이용하여 각 사용자에게 부반송파를 적절하게 나누어주도록 한다. 도 4는 각 안테나 경로에 대한 MCS 레벨 결정 알고리즘의 동작 예시도를 도시한 것이다.

도 4에 도시된 바와 같이, 기지국은 단말기의 채널 추정부(260)로부터 전달된 채널 정보를 이용하여 안테나 경로에 대해 MCS 레벨과 CVL 값을 계산하게 된다.

우선 단말기는 기지국으로부터 무작위로 생성된 256CGN[0, 2, 3, 5]을 하향링크 제어 채널을 통해 전달받고, 베스트 32CG[4, 1, 2, 0]을 구한다.

단말기는 최소 MCS 레벨  $K=4$ 을 결정한 후에 1~4까지 각 MCS 레벨에 따른 CVL 값과 전송량을 계산한다. 이때, 최대 전송량을 갖는 MCS 레벨이 3이므로 해당 안테나 경로에 대한 MCS 레벨 값은 3, CVL은 128이 된다.

단말기는 위의 절차를 모든 안테나 경로(1~N)에 대해 수행하는데, 다른 안테나 경로에서 베스트 32CG는 첫 번째 안테나 경로에서 구한 [4, 1, 2, 0] 값을 이용하고, 이를 기준으로 MCS 레벨과 CVL 값을 구한다. 그리고, 다른 안테나 경로에 대해 MCS 레벨은 앞에서 구한 최소 MCS 레벨이 3이므로 1~3까지만 증가하며 CVL 값을 구하게 된다.

도 5는 본 발명에 따른 실시예의 직교주파수 분할다중에서의 채널 정보 결정 시스템을 MIMO(Multiple Input Multiple Output)-직교주파수 분할다중 시스템에 적용할 예를 도시한 것이다.

도 5에 나타나 있듯이, 기지국 안테나와 단말기 안테나가  $2 \times 2$ 인 경우에, 단말기는 안테나 경로 4개에 대해 각 채널 정보를 측정할 수 있다.

만약, 단말기가 각각의 안테나 경로에 대한 채널 정보를 기지국으로 전송하는 경우에, 상향링크 제어 채널을 통해 기지국으로 피드백정보는 안테나 경로 수만큼 증가하게 된다.

따라서, MIMO-OFDM 시스템에서는 안테나 경로의 수와 상관없이 모든 안테나 경로에 대해 본 발명에 따른 실시예의 방법을 적용하여 최소 MCS 레벨 값과 CVL의 대표되는 값을 전송한다.

이로 인해, MIMO-OFDM 시스템에서는 많은 양의 피드백 정보를 요구하지 않고 주파수 효율의 증가를 기대할 수 있다.

상기 도면과 발명의 상세한 설명은 단지 본 발명의 예시적인 것으로서, 이는 단지 본 발명을 설명하기 위한 목적에서 사용된 것이지 의미한정이나 특허청구범위에 기재된 본 발명의 범위를 제한하기 위하여 사용된 것은 아니다. 그러므로 본 기술 분야의 통상의 지식을 가진 자라면 이로부터 다양한 변형 및 균등한 타 실시예가 가능하다는 점을 이해할 것이다. 따라서, 본 발명의 진정한 기술적 보호 범위는 첨부된 특허청구범위의 기술적 사상에 의해 정해져야 할 것이다.

#### 발명의 효과

본 발명에 의한 직교주파수 분할다중에서의 채널 정보 결정 시스템 및 방법, 그 프로그램이 저장된 기록매체는 단말기에서 해당 부반송파에 대한 채널 정보만을 피드백하므로 기존에 비해 오버헤드의 증가없이 적응 변조/코드 성능을 향상시킬 수 있고, 최대 전송량을 갖는 변조/코드 비율과 채널 변화율의 조합을 선택하므로 시스템 성능을 향상시킬 수 있는 효과가 있다.

또한, 본 발명에 의한 직교주파수 분할다중에서의 채널 정보 결정 시스템 및 방법, 그 프로그램이 저장된 기록매체는 각 안테나 경로에 대해 채널 정보를 피드백하지 않고 모든 안테나 경로를 고려한 변조/코드 비율과 채널 변화율을 결정하므로 많은 양의 피드백 정보를 요구하지 않는다는 효과도 있다.

#### (57) 청구의 범위

##### 청구항 1.

- 기지국으로부터 전송되는 부반송파 그룹의 정보를 수신하고, 상기 부반송파 그룹들 중에서 채널 환경을 고려하여 최상의 부반송파 그룹을 선택하는 단계;
- 상기 a) 단계에서 선택한 최상의 부반송파 그룹에서 변조/코드 비율을 구한 후에 상기 변조/코드 비율 중에서 최소 변조/코드 비율을 결정하는 단계;
- 상기 b) 단계에서 결정한 최소 변조/코드 비율까지 변조/코드 비율의 레벨을 증가시키면서 각 변조/코드 비율마다 모든 안테나 경로에 대해 각 부반송파 그룹 내 채널 변화율과 전송량을 구하는 단계; 및
- 상기 c) 단계를 통해 각 안테나 경로에 대해 변조/코드 비율과 채널 변화율을 이용하여 대표 값을 결정하고, 해당 부반송파에 대한 상기 변조/코드 비율과 채널 변화 레벨 정보를 기지국으로 피드백하는 단계를 포함하는 직교주파수 분할다중에서의 채널 정보 결정 방법.

##### 청구항 2.

제 1 항에 있어서,

상기 b) 단계에서 변조/코드 비율은 부반송파별 수신 신호대잡음비에 맞추어 결정되는 변조방식 및 부호율의 조합을 나타내고, 상기 c) 단계에서 채널 변화율은 인접 부반송파 그룹들 간의 채널 유사 정도를 나타내는 것을 특징으로 하는 직교주파수 분할다중에서의 채널 정보 결정 방법.

##### 청구항 3.

제 1 항에 있어서,

상기 c) 단계는,

가) 제1 안테나 경로에 대해 상기 변조/코드 비율( $j=1\sim K$ )을 상기 최소 변조/코드 비율( $K$ )까지 증가시키며 각 변조/코드 비율마다 부반송파 그룹 내 유사한 변조/코드 비율을 갖는 채널 변화율을 구하는 단계;

나) 상기 나) 단계에서 구한 부반송파 그룹 중 최소 채널 변화율을 기준으로 해당 변조/코드 비율에 대한 전송량을 계산하는 단계;

다) 상기 나) 단계에서 구한 전송량을 각 변조/코드 비율마다 비교하여 최대 전송량을 갖는 변조/코드 비율과 채널 변화율을 결정하는 단계; 및

라) 다른 안테나 경로에 대해 상기 제1 안테나 경로의 최상의 부반송파 그룹을 기준으로 각 변조/코드 비율마다 채널 변화율을 구하는 단계

를 포함하는 하는 직교주파수 분할다중에서의 채널 정보 결정 방법.

#### 청구항 4.

제 1 항에 있어서,

상기 d) 단계에서 안테나 경로에 대해 대표 값을 결정하는 단계는,

상기 특정 안테나 경로에 대해 각 변조/코드 비율과 채널 변화율의 조합에 있어 최대 전송량을 갖는 변조/코드 비율과 채널 변화율을 해당 안테나 경로에 대한 대표 값으로 사용하는 것을 특징으로 하는 직교주파수 분할다중에서의 채널 정보 결정 방법.

#### 청구항 5.

제 1 항에 있어서,

상기 d) 단계에서 안테나 경로에 대해 대표 값을 결정하는 단계는,

상기 모든 안테나 경로 중에서 최소 변조/코드 비율과 채널 변화율을 기준으로 모든 안테나 경로에 대한 대표 값으로 사용하는 것을 특징으로 하는 직교주파수 분할다중에서의 채널 정보 결정 방법.

#### 청구항 6.

제 1 항에 있어서,

상기 d) 단계에서 안테나 경로에 대해 대표 값이 결정되면, 상기 단말기는 변조/코드 비율과 채널 변화율 정보를 이용하여 기지국으로부터의 송신 데이터를 부반송파별로 복조하고, 상기 부반송파별 복조된 데이터 중에서 자신에게 할당된 부반송파 그룹의 트래픽만을 선별하는 단계를 포함하는 것을 특징으로 하는 직교주파수 분할다중에서의 채널 정보 결정 방법.

#### 청구항 7.

제 1 항에 있어서,

상기 d) 단계에서 안테나 경로에 대해 대표 값이 결정되면, 상기 단말기는 상기 변조/코드 비율과 채널 변화율을 저장하고, 상기 저장된 변조/코드비율과 채널 변화율 정보를 기지국으로 전송되는 다음 송신 데이터의 복조시 사용하는 것을 특징으로 하는 직교주파수 분할다중에서의 채널 정보 결정 방법.

#### 청구항 8.

제 1 항에 있어서,

상기 d) 단계에서 피드백되는 정보를 기지국이 수신하면,

상기 기지국은 상기 단말기로부터의 피드백 정보를 이용하여 각 단말기마다 적정 부반송파가 할당되도록 스케줄링하는 것을 특징으로 하는 직교주파수 분할다중에서의 채널 정보 결정 방법.

#### 청구항 9.

기지국으로부터 부반송파별 채널 정보를 획득하여 그 채널 정보에 따라 모든 안테나 경로에 대해 변조/코드 비율을 결정하고, 상기 변조/코드 비율 정보를 토대로 송신 데이터의 적응 복조를 수행하여 각 단말기별 할당된 부반송파 그룹의 트래픽 데이터만을 선별하는 다수의 수신장치; 및

상기 수신장치로부터 해당 부반송파에 대한 변조/코드 비율 정보를 피드백받아 이를 이용하여 각 사용자에게 부반송파를 정당하게 배분하고, 각 사용자에게 할당된 부반송파 그룹별 적응 변조된 송신 데이터를 상기 수신장치로 전송하는 송신장치

을 포함하는 직교주파수 분할다중에서의 채널 정보 결정 시스템.

#### 청구항 10.

제 9 항에 있어서,

상기 변조/코드 비율은 부반송파별 수신 신호대잡음비에 맞추어 결정되는 변조방식 및 부호율의 조합, 상기 채널 변화율은 인접 부반송파 그룹들 간의 채널 유사 정도를 각각 나타내는 것을 특징으로 하는 직교주파수 분할다중에서의 채널 정보 결정 시스템.

#### 청구항 11.

제 9 항에 있어서,

상기 수신 장치는 각 안테나 경로에 대해 변조/코드 비율과 채널 변화율의 조합에 있어 최대 전송량을 갖는 조합을 해당 안테나 경로에 대한 대표 값으로 결정하는 것을 특징으로 하는 직교주파수 분할다중에서의 채널 정보 결정 시스템.

#### 청구항 12.

제 9 항에 있어서,

상기 수신장치는 각 안테나 경로에 대해 최소 변조/코드 비율과 채널 변화율을 기준으로 모든 안테나 경로에 대한 대표 값을 결정하는 것을 특징으로 하는 직교주파수 분할다중에서의 채널 정보 결정 시스템.

#### 청구항 13.

제 9 항에 있어서,  
 상기 수신 장치는  
 상기 송신장치로부터 전송되는 송신 데이터의 파일럿(Pilot) 신호로부터 각 부반송파 그룹별 채널 상태 정보를 획득하고, 상기 채널 상태 정보에 따라 변조/코드 비율을 결정하는 채널 추정부; 및  
 상기 채널 추정부에서 결정된 변조/코드 비율 정보를 저장하고, 상기 저장된 변조/코드 비율 정보를 다음 송신 데이터 복조시 사용하도록 MCS 정보 저장부;  
 상기 MCS 정보 저장부에 저장되어 있는 변조/코드 비율 정보를 이용하여 상기 송신장치로부터 전송되는 송신 데이터를 적응 복조하는 적응 복조부; 및  
 상기 적응 복조부에서 복조된 데이터 중에서 부반송파 할당 정보를 이용하여 각 사용자별 할당된 부반송파 그룹의 트래픽 데이터만을 선별하는 부반송파 선별부를 포함하는 직교주파수 분할다중에서의 채널 정보 결정 시스템.

#### 청구항 14.

제 9 항에 있어서,  
 상기 송신 장치는  
 상기 수신 장치마다 피드백되는 피드백정보를 각 사용자별 저장하는 피드백 정보 집합부;  
 상기 피드백 정보 집합부의 피드백 정보를 이용하여 패킷 스케줄링을 수행하여 각 사용자에게 할당할 부반송파 정보와 적응 변조 정보를 생성 출력시키는 패킷 스케줄러;  
 상기 패킷 스케줄러의 부반송파 정보를 전달받아 각 사용자에게 부반송파를 적정하게 나누어주는 부반송파 할당부; 및  
 상기 부반송파 할당부에서 각 사용자별 할당된 부반송파에 실리는 데이터를 상기 패킷 스케줄러의 적응 변조 정보에 맞추어 변조하는 적응 변조부를 포함하는 직교주파수 분할다중에서의 채널 정보 결정 시스템.

#### 청구항 15.

기지국으로부터 전송되는 부반송파 그룹의 정보를 수신하고, 상기 부반송파 그룹들 중에서 채널 환경을 고려하여 최상의 부반송파 그룹을 선택하는 제1 기능;  
 상기 최상의 부반송파 그룹에서 변조/코드 비율을 구한 후에 상기 변조/코드 비율 중에서 최소 변조/코드 비율을 결정하는 제2 기능;  
 상기 최소 변조/코드 비율까지 변조/코드 비율의 레벨을 증가시키면서 각 변조/코드 비율마다 모든 안테나 경로에 대해 각 부반송파 그룹 내 채널 변화율과 전송량을 구하는 제3 기능; 및  
 상기 각 안테나 경로에 대해 변조/코드 비율과 채널 변화율을 이용하여 대표 값을 결정하고, 해당 부반송파에 대한 상기 변조/코드 비율과 채널 변화 레벨 정보를 기지국으로 피드백하는 제4 기능을 포함하는 프로그램이 저장된 기록매체.

도면

도면1

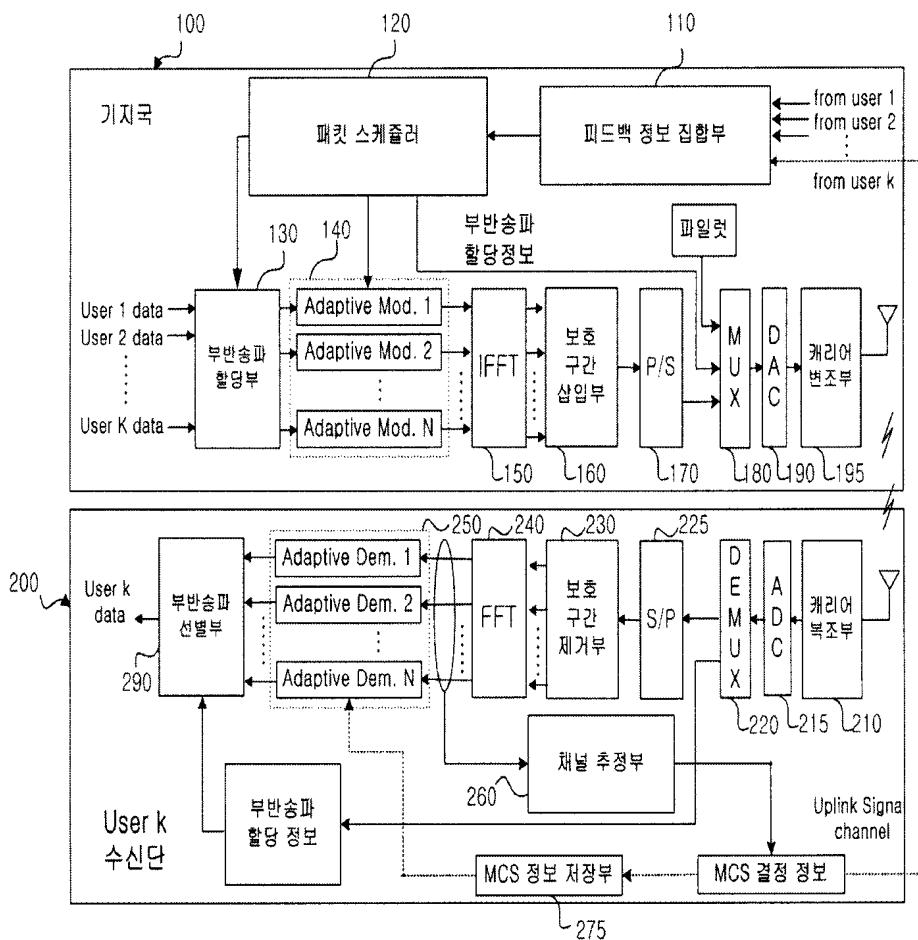

도면2

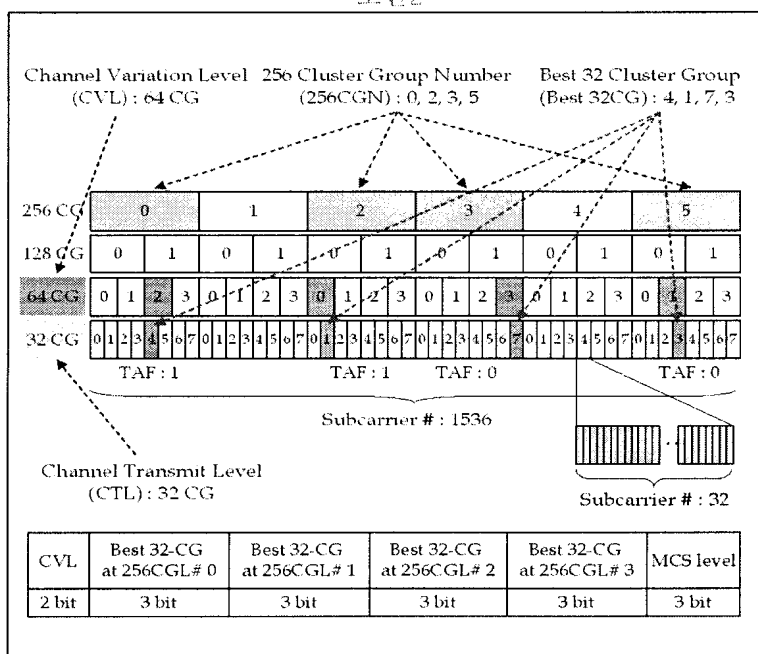

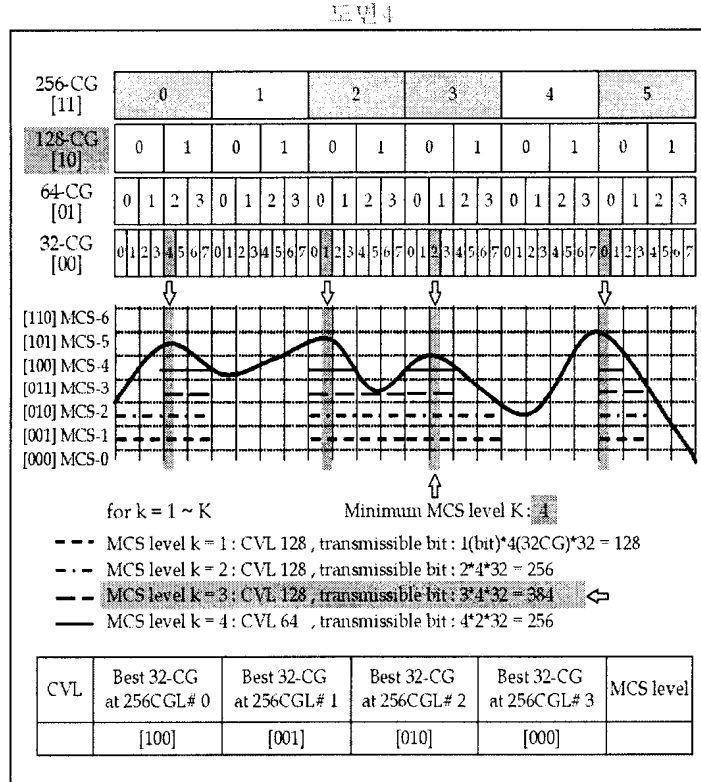
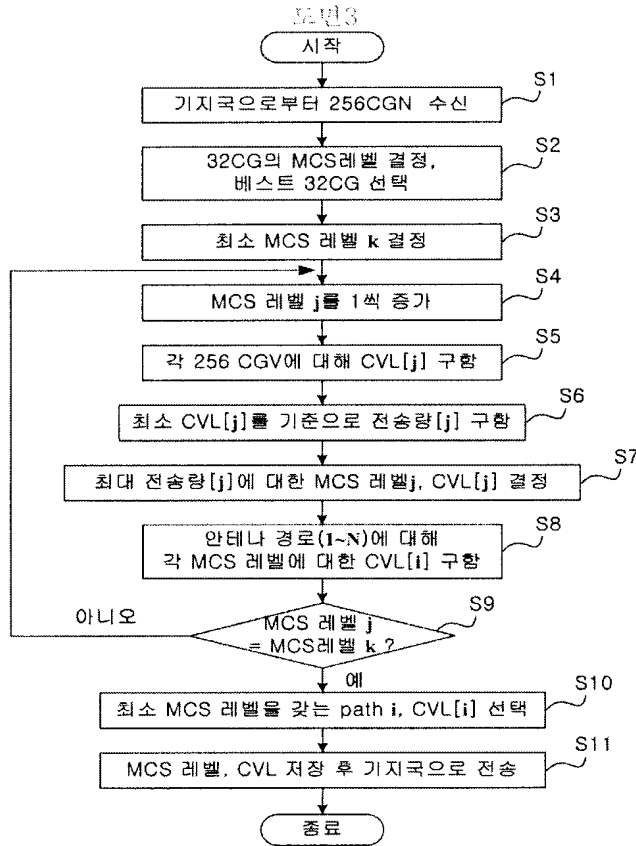

도면5

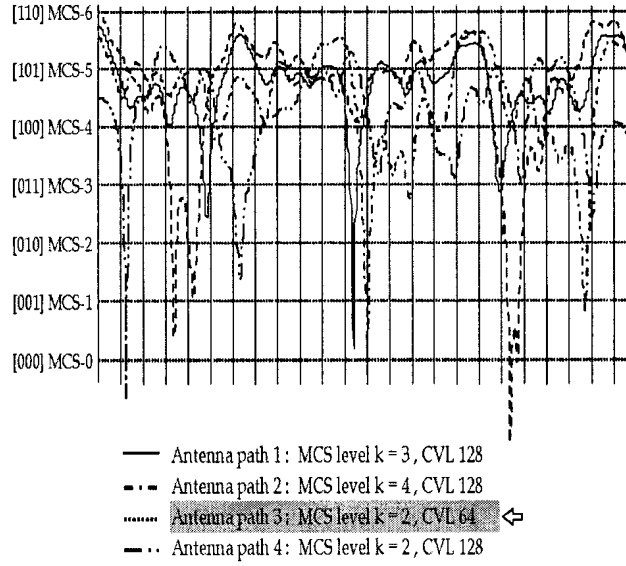

CVL	Best 32-CG at 256CGL# 0	Best 32-CG at 256CGL# 1	Best 32-CG at 256CGL# 2	Best 32-CG at 256CGL# 3	MCS level
[01]	[100]	[001]	[010]	[000]	[010]

## Electronic Acknowledgement Receipt

<b>EFS ID:</b>	5281443
<b>Application Number:</b>	12209136
<b>International Application Number:</b>	
<b>Confirmation Number:</b>	3897
<b>Title of Invention:</b>	METHOD FOR TRANSMITTING UPLINK SIGNALS
<b>First Named Inventor/Applicant Name:</b>	Dae Won Lee
<b>Customer Number:</b>	35884
<b>Filer:</b>	Puya Partow-Navid
<b>Filer Authorized By:</b>	
<b>Attorney Docket Number:</b>	2101-3573
<b>Receipt Date:</b>	05-MAY-2009
<b>Filing Date:</b>	11-SEP-2008
<b>Time Stamp:</b>	17:44:27
<b>Application Type:</b>	Utility under 35 USC 111(a)

### Payment information:

Submitted with Payment	no
------------------------	----

### File Listing:

Document Number	Document Description	File Name	File Size(Bytes)/ Message Digest	Multi Part /.zip	Pages (if appl.)
1	Information Disclosure Statement (IDS) Filed (SB/08)	IDS_1449.pdf	607887 <small>b358c9ab29a3aa7420f6d9cdeb6701c31d78b36e0</small>	no	4

### Warnings:

### Information:

2	f1_2.pdf	1796963	yes	37
<b>Multipart Description/PDF files in .zip description</b>				
<b>Document Description</b>		<b>Start</b>	<b>End</b>	
Foreign Reference		1	26	
Foreign Reference		27	37	
<b>Warnings:</b>				
<b>Information:</b>				
<b>Total Files Size (in bytes):</b>			2404850	
<p><b>This Acknowledgement Receipt evidences receipt on the noted date by the USPTO of the indicated documents, characterized by the applicant, and including page counts, where applicable. It serves as evidence of receipt similar to a Post Card, as described in MPEP 503.</b></p> <p><b><u>New Applications Under 35 U.S.C. 111</u></b>  <b>If a new application is being filed and the application includes the necessary components for a filing date (see 37 CFR 1.53(b)-(d) and MPEP 506), a Filing Receipt (37 CFR 1.54) will be issued in due course and the date shown on this Acknowledgement Receipt will establish the filing date of the application.</b></p> <p><b><u>National Stage of an International Application under 35 U.S.C. 371</u></b>  <b>If a timely submission to enter the national stage of an international application is compliant with the conditions of 35 U.S.C. 371 and other applicable requirements a Form PCT/DO/EO/903 indicating acceptance of the application as a national stage submission under 35 U.S.C. 371 will be issued in addition to the Filing Receipt, in due course.</b></p> <p><b><u>New International Application Filed with the USPTO as a Receiving Office</u></b>  <b>If a new international application is being filed and the international application includes the necessary components for an international filing date (see PCT Article 11 and MPEP 1810), a Notification of the International Application Number and of the International Filing Date (Form PCT/RO/105) will be issued in due course, subject to prescriptions concerning national security, and the date shown on this Acknowledgement Receipt will establish the international filing date of the application.</b></p>				



**UNITED STATES PATENT AND TRADEMARK OFFICE**

UNITED STATES DEPARTMENT OF COMMERCE  
**United States Patent and Trademark Office**  
 Address: COMMISSIONER FOR PATENTS  
 P.O. Box 1450  
 Alexandria, Virginia 22313-1450  
 www.uspto.gov

APPLICATION NUMBER	FILING OR 371(C) DATE	FIRST NAMED APPLICANT	ATTY. DOCKET NO./TITLE
12/209,136	09/11/2008	Dae Won Lee	2101-3573

**CONFIRMATION NO. 3897**
**PUBLICATION NOTICE**

35884  
 LEE, HONG, DEGERMAN, KANG & WAIMEY  
 660 S. FIGUEROA STREET  
 Suite 2300  
 LOS ANGELES, CA 90017



**Title:**METHOD FOR TRANSMITTING UPLINK SIGNALS

**Publication No.**US-2009-0097466-A1

**Publication Date:**04/16/2009

**NOTICE OF PUBLICATION OF APPLICATION**

The above-identified application will be electronically published as a patent application publication pursuant to 37 CFR 1.211, et seq. The patent application publication number and publication date are set forth above.

The publication may be accessed through the USPTO's publically available Searchable Databases via the Internet at [www.uspto.gov](http://www.uspto.gov). The direct link to access the publication is currently <http://www.uspto.gov/patft/>.

The publication process established by the Office does not provide for mailing a copy of the publication to applicant. A copy of the publication may be obtained from the Office upon payment of the appropriate fee set forth in 37 CFR 1.19(a)(1). Orders for copies of patent application publications are handled by the USPTO's Office of Public Records. The Office of Public Records can be reached by telephone at (703) 308-9726 or (800) 972-6382, by facsimile at (703) 305-8759, by mail addressed to the United States Patent and Trademark Office, Office of Public Records, Alexandria, VA 22313-1450 or via the Internet.

In addition, information on the status of the application, including the mailing date of Office actions and the dates of receipt of correspondence filed in the Office, may also be accessed via the Internet through the Patent Electronic Business Center at [www.uspto.gov](http://www.uspto.gov) using the public side of the Patent Application Information and Retrieval (PAIR) system. The direct link to access this status information is currently <http://pair.uspto.gov/>. Prior to publication, such status information is confidential and may only be obtained by applicant using the private side of PAIR.

Further assistance in electronically accessing the publication, or about PAIR, is available by calling the Patent Electronic Business Center at 1-866-217-9197.

Office of Data Management, Application Assistance Unit (571) 272-4000, or (571) 272-4200, or 1-888-786-0101



## UNITED STATES PATENT AND TRADEMARK OFFICE

UNITED STATES DEPARTMENT OF COMMERCE  
 United States Patent and Trademark Office  
 Address: COMMISSIONER FOR PATENTS  
 P.O. Box 1450  
 Alexandria, Virginia 22313-1450  
 www.uspto.gov

APPLICATION NUMBER	FILING or 371(c) DATE	GRP ART UNIT	FIL FEE REC'D	ATTY. DOCKET NO	TOT CLAIMS	IND CLAIMS
12/209,136	09/11/2008	2617	1530	2101-3573	8	2

CONFIRMATION NO. 3897

UPDATED FILING RECEIPT

35884

LEE, HONG, DEGERMAN, KANG & WAIMEY  
 660 S. FIGUEROA STREET  
 Suite 2300  
 LOS ANGELES, CA 90017



Date Mailed: 01/08/2009

Receipt is acknowledged of this non-provisional patent application. The application will be taken up for examination in due course. Applicant will be notified as to the results of the examination. Any correspondence concerning the application must include the following identification information: the U.S. APPLICATION NUMBER, FILING DATE, NAME OF APPLICANT, and TITLE OF INVENTION. Fees transmitted by check or draft are subject to collection. Please verify the accuracy of the data presented on this receipt. **If an error is noted on this Filing Receipt, please submit a written request for a Filing Receipt Correction. Please provide a copy of this Filing Receipt with the changes noted thereon. If you received a "Notice to File Missing Parts" for this application, please submit any corrections to this Filing Receipt with your reply to the Notice. When the USPTO processes the reply to the Notice, the USPTO will generate another Filing Receipt incorporating the requested corrections**

**Applicant(s)**

Dae Won Lee, Gyeonggi-do, KOREA, REPUBLIC OF;  
 Bong Hoe Kim, Gyeonggi-do, KOREA, REPUBLIC OF;  
 Young Woo Yun, Gyeonggi-do, KOREA, REPUBLIC OF;  
 Ki Jun Kim, Gyeonggi-do, KOREA, REPUBLIC OF;  
 Dong Wook Roh, Gyeonggi-do, KOREA, REPUBLIC OF;  
 Hak Seong Kim, Gyeonggi-do, KOREA, REPUBLIC OF;  
 Hyun Wook Park, Gyeonggi-do, KOREA, REPUBLIC OF;

**Assignment For Published Patent Application**

LG Electronics Inc.

**Power of Attorney:** The patent practitioners associated with Customer Number 035884

**Domestic Priority data as claimed by applicant**

This appln claims benefit of 60/972,244 09/13/2007  
 and claims benefit of 60/987,427 11/13/2007  
 and claims benefit of 60/988,433 11/16/2007

**Foreign Applications**

REPUBLIC OF KOREA 10-2008-0068634 07/15/2008

**If Required, Foreign Filing License Granted:** 09/24/2008

The country code and number of your priority application, to be used for filing abroad under the Paris Convention, is **US 12/209,136**

**Projected Publication Date:** 04/16/2009

**Non-Publication Request:** No

**Early Publication Request:** No  
**Title**

METHOD FOR TRANSMITTING UPLINK SIGNALS

**Preliminary Class**

370

## **PROTECTING YOUR INVENTION OUTSIDE THE UNITED STATES**

Since the rights granted by a U.S. patent extend only throughout the territory of the United States and have no effect in a foreign country, an inventor who wishes patent protection in another country must apply for a patent in a specific country or in regional patent offices. Applicants may wish to consider the filing of an international application under the Patent Cooperation Treaty (PCT). An international (PCT) application generally has the same effect as a regular national patent application in each PCT-member country. The PCT process **simplifies** the filing of patent applications on the same invention in member countries, but **does not result** in a grant of "an international patent" and does not eliminate the need of applicants to file additional documents and fees in countries where patent protection is desired.

Almost every country has its own patent law, and a person desiring a patent in a particular country must make an application for patent in that country in accordance with its particular laws. Since the laws of many countries differ in various respects from the patent law of the United States, applicants are advised to seek guidance from specific foreign countries to ensure that patent rights are not lost prematurely.

Applicants also are advised that in the case of inventions made in the United States, the Director of the USPTO must issue a license before applicants can apply for a patent in a foreign country. The filing of a U.S. patent application serves as a request for a foreign filing license. The application's filing receipt contains further information and guidance as to the status of applicant's license for foreign filing.

Applicants may wish to consult the USPTO booklet, "General Information Concerning Patents" (specifically, the section entitled "Treaties and Foreign Patents") for more information on timeframes and deadlines for filing foreign patent applications. The guide is available either by contacting the USPTO Contact Center at 800-786-9199, or it can be viewed on the USPTO website at <http://www.uspto.gov/web/offices/pac/doc/general/index.html>.

For information on preventing theft of your intellectual property (patents, trademarks and copyrights), you may wish to consult the U.S. Government website, <http://www.stopfakes.gov>. Part of a Department of Commerce initiative, this website includes self-help "toolkits" giving innovators guidance on how to protect intellectual property in specific countries such as China, Korea and Mexico. For questions regarding patent enforcement issues, applicants may call the U.S. Government hotline at 1-866-999-HALT (1-866-999-4158).

### **LICENSE FOR FOREIGN FILING UNDER**

**Title 35, United States Code, Section 184**

**Title 37, Code of Federal Regulations, 5.11 & 5.15**

#### **GRANTED**

The applicant has been granted a license under 35 U.S.C. 184, if the phrase "IF REQUIRED, FOREIGN FILING LICENSE GRANTED" followed by a date appears on this form. Such licenses are issued in all applications where

the conditions for issuance of a license have been met, regardless of whether or not a license may be required as set forth in 37 CFR 5.15. The scope and limitations of this license are set forth in 37 CFR 5.15(a) unless an earlier license has been issued under 37 CFR 5.15(b). The license is subject to revocation upon written notification. The date indicated is the effective date of the license, unless an earlier license of similar scope has been granted under 37 CFR 5.13 or 5.14.

This license is to be retained by the licensee and may be used at any time on or after the effective date thereof unless it is revoked. This license is automatically transferred to any related applications(s) filed under 37 CFR 1.53(d). This license is not retroactive.

The grant of a license does not in any way lessen the responsibility of a licensee for the security of the subject matter as imposed by any Government contract or the provisions of existing laws relating to espionage and the national security or the export of technical data. Licensees should apprise themselves of current regulations especially with respect to certain countries, of other agencies, particularly the Office of Defense Trade Controls, Department of State (with respect to Arms, Munitions and Implements of War (22 CFR 121-128)); the Bureau of Industry and Security, Department of Commerce (15 CFR parts 730-774); the Office of Foreign Assets Control, Department of Treasury (31 CFR Parts 500+) and the Department of Energy.

**NOT GRANTED**

No license under 35 U.S.C. 184 has been granted at this time, if the phrase "IF REQUIRED, FOREIGN FILING LICENSE GRANTED" DOES NOT appear on this form. Applicant may still petition for a license under 37 CFR 5.12, if a license is desired before the expiration of 6 months from the filing date of the application. If 6 months has lapsed from the filing date of this application and the licensee has not received any indication of a secrecy order under 35 U.S.C. 181, the licensee may foreign file the application pursuant to 37 CFR 5.15(b).

PATENT DOCKET NO. 2101-3573  
CUSTOMER NO. 035884

IN THE UNITED STATES PATENT AND TRADEMARK OFFICE

In re application of: Dae Won Lee et al. Serial No: 12/209,136 Filed: September 11, 2008 For: METHOD FOR TRANSMITTING UPLINK SIGNALS	Art Unit: - Examiner: - Confirmation No. 3897
--	---

TRANSMITTAL OF MISSING PARTS

Mail Stop Missing Parts  
Commissioner for Patents  
P. O. Box 1450  
Alexandria, VA 22313-1450

Dear Sir:

In response to the "Notice to File Missing Parts of Nonprovisional Application" dated September 25, 2008 for the above-identified application, enclosed are:

1. A signed Declaration and Power of Attorney. And
2. Replacement drawings (7 sheets, FIGS. 3-9).

We confirm that the English translations of the prior-filed provisional applications Nos. 60/972,244, 60/988,433 and 60/987,427 and statements that the translations are accurate have been filed in the prior-filed provisional applications.

- To the extent necessary, a petition for an extension of time under 37 C.F.R. 1.136 is hereby made. Please charge any additional fees due or credit any overpayment in connection with the filing of this concurrent and future replies, including extension of time fees, to Deposit Account 502290.

Respectfully submitted,

LEE, HONG, DEGERMAN, KANG & WAIMEY

Date: December 26, 2008

By: /Harry S. Lee/  
Harry S. Lee  
Registration No. 56,814

Customer No. 035884

PATENT (U.S.A.)

ATTORNEY'S DOCKET NO. 2101-3573

**DECLARATION  
and POWER OF ATTORNEY**

- ORIGINAL  
 CONTINUATION-IN-PART  
 DIVISIONAL

As a below named inventor, I declare that the information given herein is true, that I believe that I am the original, first and sole inventor (if only one name is listed as 1 below) or an original, first and joint inventor (if plural names are listed below) of the subject matter which is claimed and for which a patent is sought on the invention entitled:

**METHOD FOR TRANSMITTING UPLINK SIGNALS**

the specification of which is attached hereto unless the following box is checked:

was filed on September 11, 2008 as United States Application Number 12/209,136.

My residence, post office address and citizenship are as stated below next to my name. I acknowledge my duty to disclose information, which is material to the patentability of this application in accordance with Title 37, Code of Federal Regulations § 1.56(a). I hereby state that I have reviewed and understand the contents of the above identified specification, including the claims, as amended by any amendment referred to above. I hereby claim foreign priority benefits under Title 35, United States Code, § 119 OR 365(b) of any foreign application(s) for patent or inventor's certificate, or 365(a) of any PCT international application which designated at least one country other than the United States of America, listed below and have also identified below any foreign application for patent or inventor's certificate, or any PCT international application having a filing date before that of the application on which priority is claimed:

PRIOR FOREIGN APPLICATION(S)

COUNTRY	APPLICATION NUMBER	DATE OF FILING Month Day Year	PRIORITY CLAIMED UNDER 35 U.S.C. 119
Korea	10-2008-0068634	July 15, 2008	YES

I hereby claim the benefit under Title 35, United States Code, §119 of any United States application(s) listed below and, insofar as the subject matter of each of the claims of this application is not disclosed in the prior United States application in the manner provided by the first paragraph of Title 35, United States Code § 112, I acknowledge the duty to disclose material information as defined in Title 37, Code of Federal Regulations, § 1.56(a) which occurred between the filing date of the prior application and the national or PCT international filing date of this application.

60/972,244	September 13, 2007	Provisional
60/987,427	November 13, 2007	Provisional
60/988,433	November 16, 2007	Provisional
(Application Serial No.)	(Filing Date)	(Status)

**POWER OF ATTORNEY:** As a named Inventor, I hereby appoint the following attorney(s) and/or Agent(s) to prosecute this application and transact all business in the Patent and Trademark Office connected therewith:

**THE ATTORNEYS ASSOCIATED WITH CUSTOMER NO. 035884**

SEND  
CORRESPONDENCE  
TO:

Jonathan Y. Kang, Esq.  
**LEE, HONG, DEGERMAN, KANG &  
WAIMEY**  
At the address associated with  
Customer No. 35884



TELEPHONE NO.: (213) 623-2221

FAX NO.: (213) 623-2211/8601

1	Name of Inventor	Residence: CITY	STATE or COUNTRY
	Dae Won LEE	Gyeonggi-do	Republic of Korea
	Mailing Address		CITIZENSHIP
	LG Institute, Hogye 1(il)-dong, Dongan-gu, Anyang-si Gyeonggi-do, 431-749, Korea		Republic of Korea
2	Name of Inventor	Residence: CITY	STATE or COUNTRY
	Bong Hoe KIM	Gyeonggi-do	Republic of Korea
	Mailing Address		CITIZENSHIP
	LG Institute, Hogye 1(il)-dong, Dongan-gu, Anyang-si Gyeonggi-do, 431-749, Korea		Republic of Korea
3	Name of Inventor	Residence: CITY	STATE or COUNTRY
	Young Woo YUN	Gyeonggi-do	Republic of Korea
	Mailing Address		CITIZENSHIP
	LG Institute, Hogye 1(il)-dong, Dongan-gu, Anyang-si Gyeonggi-do, 431-749, Korea		Republic of Korea
4	Name of Inventor	Residence: CITY	STATE or COUNTRY
	Ki Jun KIM	Gyeonggi-do	Republic of Korea
	Mailing Address		CITIZENSHIP
	LG Institute, Hogye 1(il)-dong, Dongan-gu, Anyang-si Gyeonggi-do, 431-749, Korea		Republic of Korea
5	Name of Inventor	Residence: CITY	STATE or COUNTRY
	Dong Wook ROH	Gyeonggi-do	Republic of Korea
	Mailing Address		CITIZENSHIP
	LG Institute, Hogye 1(il)-dong, Dongan-gu, Anyang-si Gyeonggi-do, 431-749, Korea		Republic of Korea
6	Name of Inventor	Residence: CITY	STATE or COUNTRY
	Hak Seong KIM	Gyeonggi-do	Republic of Korea
	Mailing Address		CITIZENSHIP
	LG Institute, Hogye 1(il)-dong, Dongan-gu, Anyang-si Gyeonggi-do, 431-749, Korea		Republic of Korea

7	Name of Inventor	Residence: CITY	STATE or COUNTRY
	Hyun Wook PARK	Gyeonggi-do	Republic of Korea
	Mailing Address		CITIZENSHIP
	LG Institute, Hogye 1(il)-dong, Dongan-gu, Anyang-si Gyeonggi-do, 431-749, Korea		Republic of Korea

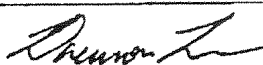
I further declare that all statements made herein of my own knowledge are true and that all statements made on information and belief are believed to be true; and further that these statements were made with the knowledge that willful false statements and the like so made are punishable by fine or imprisonment, or both, under Section 1001 of Title 18 of the United States Code, and that such willful false statements may jeopardize the validity of the application or any patent issuing thereon.

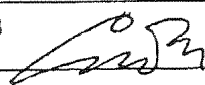
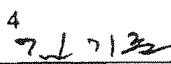
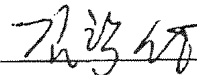
SIGNATURE OF INVENTOR 1 	SIGNATURE OF INVENTOR 2 
DATE 2008. 11. 21	DATE 2008. 11. 21
SIGNATURE OF INVENTOR 3 	SIGNATURE OF INVENTOR 4 
DATE 2008. 11. 21	DATE 2008. 11. 21
SIGNATURE OF INVENTOR 5	SIGNATURE OF INVENTOR 6 
DATE	DATE 2008. 11. 21
SIGNATURE OF INVENTOR 7	SIGNATURE OF INVENTOR 8
DATE	DATE



7	Name of Inventor	Residence: CITY	STATE or COUNTRY
	Hyun Wook PARK	Gyeonggi-do	Republic of Korea
	Mailing Address		CITIZENSHIP
	LG Institute, Hogye 1(il)-dong, Dongan-gu, Anyang-si Gyeonggi-do, 431-749, Korea		Republic of Korea

I further declare that all statements made herein of my own knowledge are true and that all statements made on information and belief are believed to be true; and further that these statements were made with the knowledge that willful false statements and the like so made are punishable by fine or imprisonment, or both, under Section 1001 of Title 18 of the United States Code, and that such willful false statements may jeopardize the validity of the application or any patent issuing thereon.

SIGNATURE OF INVENTOR 1	SIGNATURE OF INVENTOR 2
DATE	DATE
SIGNATURE OF INVENTOR 3	SIGNATURE OF INVENTOR 4
DATE	DATE
SIGNATURE OF INVENTOR 5 <i>Dong Wook Roh</i>	SIGNATURE OF INVENTOR 6
DATE <i>Nov 20, 2008</i>	DATE
SIGNATURE OF INVENTOR 7	SIGNATURE OF INVENTOR 8
DATE	DATE

7	Name of Inventor	Residence: CITY	STATE or COUNTRY
	Hyun Wook PARK	Gyeonggi-do	Republic of Korea
	Mailing Address	CITIZENSHIP	
	LG Institute, Hogye 1(il)-dong, Dongan-gu, Anyang-si Gyeonggi-do, 431-749, Korea	Republic of Korea	

I further declare that all statements made herein of my own knowledge are true and that all statements made on information and belief are believed to be true; and further that these statements were made with the knowledge that willful false statements and the like so made are punishable by fine or imprisonment, or both, under Section 1001 of Title 18 of the United States Code, and that such willful false statements may jeopardize the validity of the application or any patent issuing thereon.

SIGNATURE OF INVENTOR 1	SIGNATURE OF INVENTOR 2
DATE	DATE
SIGNATURE OF INVENTOR 3	SIGNATURE OF INVENTOR 4
DATE	DATE
SIGNATURE OF INVENTOR 5	SIGNATURE OF INVENTOR 6
DATE	DATE
SIGNATURE OF INVENTOR 7 	SIGNATURE OF INVENTOR 8
DATE <i>November 20, 2008</i>	DATE

FIG. 3

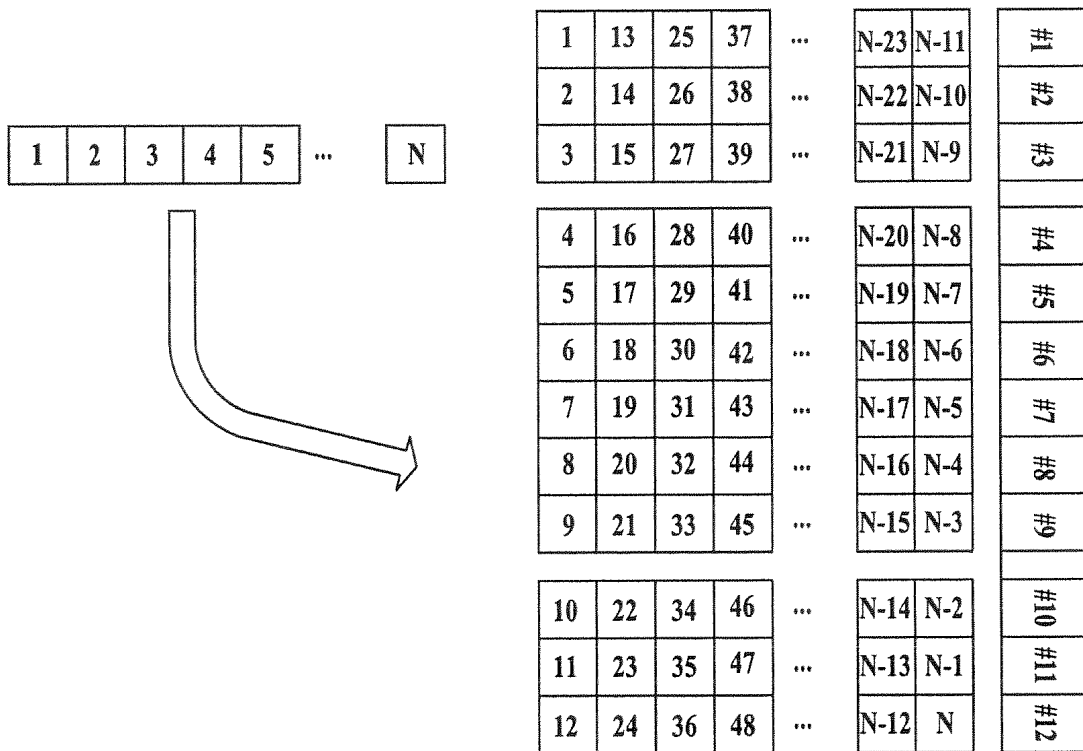

FIG. 4

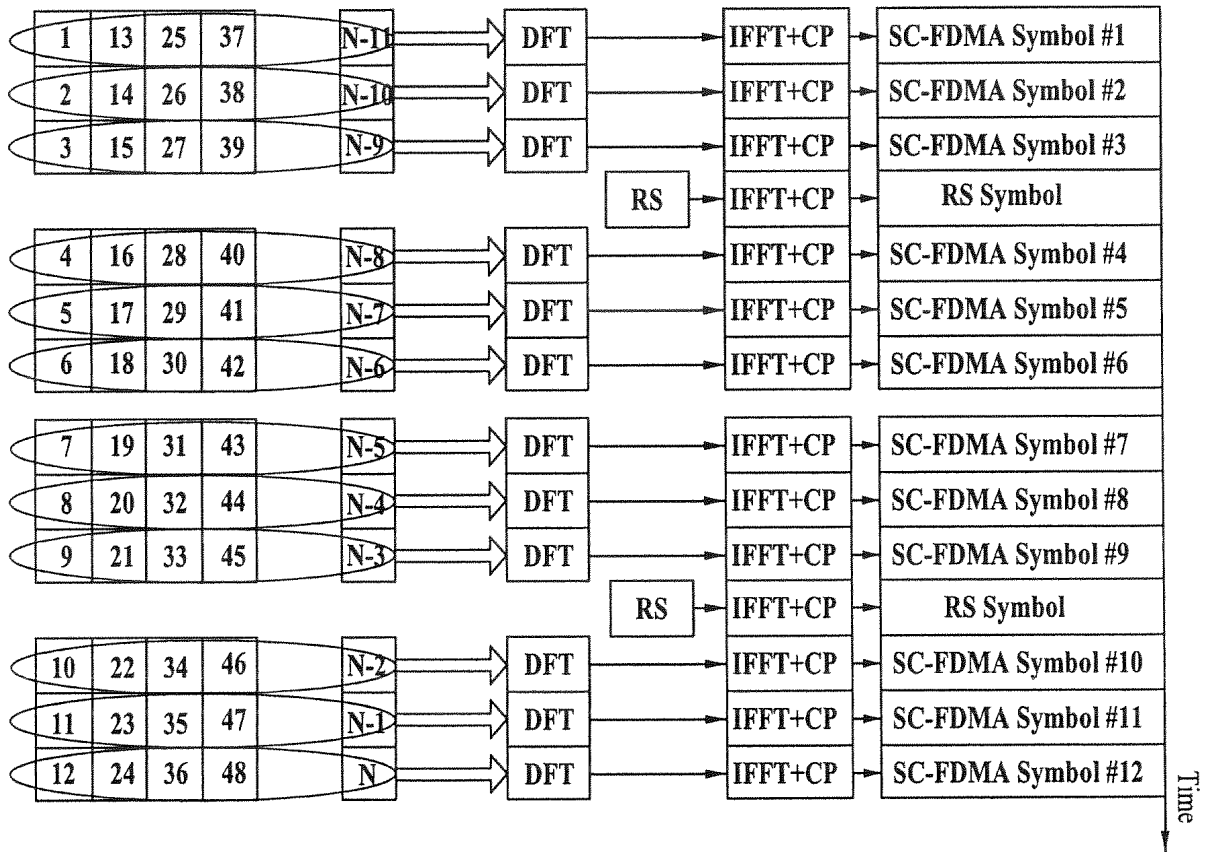

FIG. 5

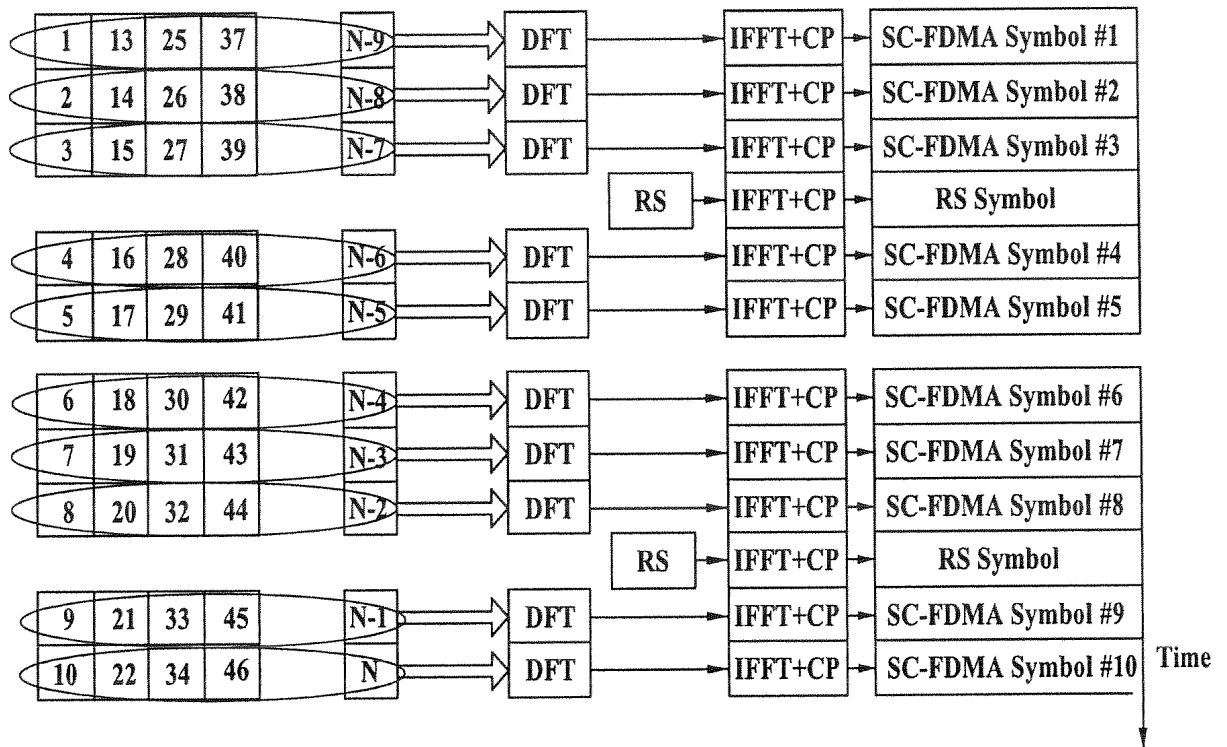

FIG. 6

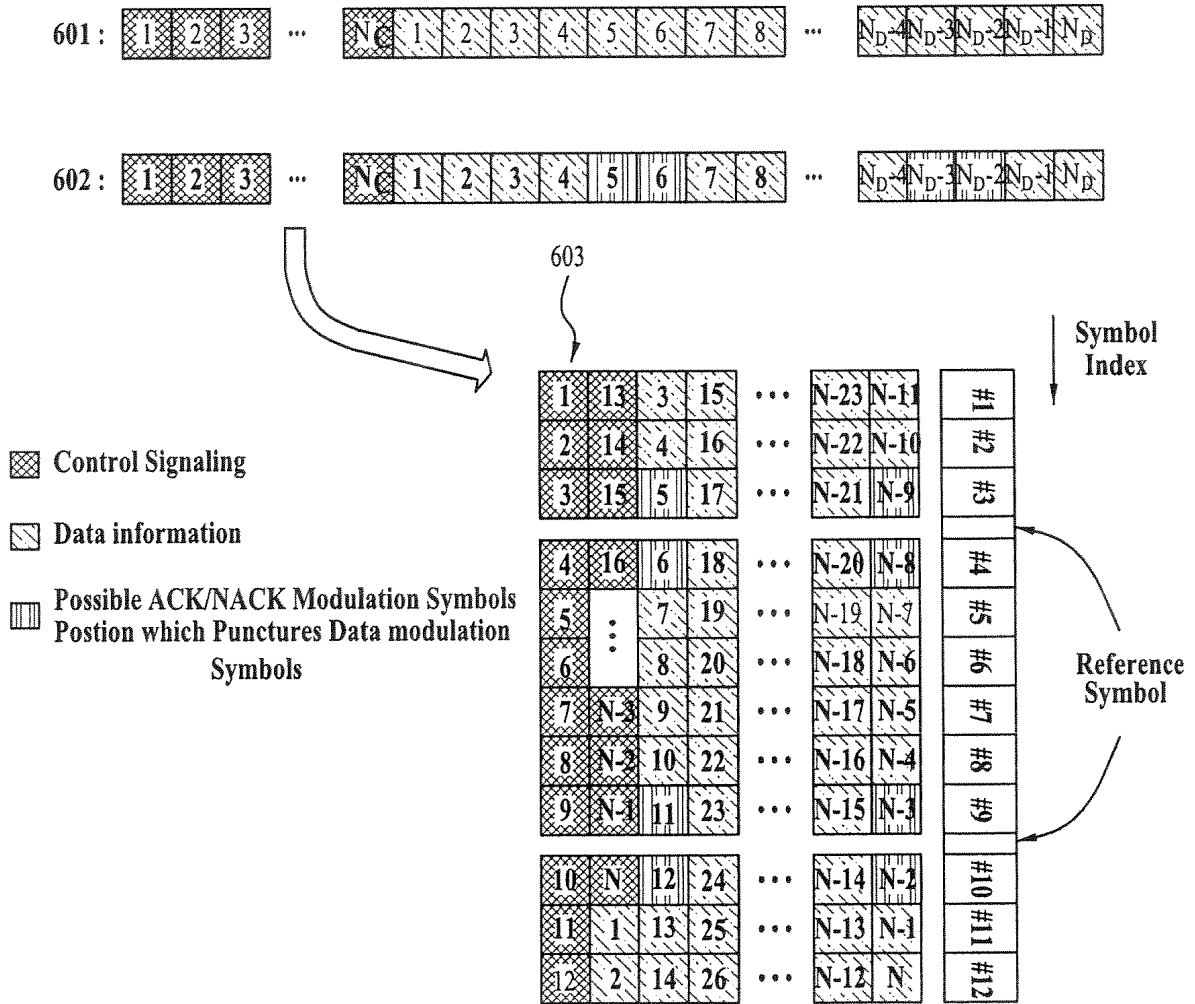

FIG. 7

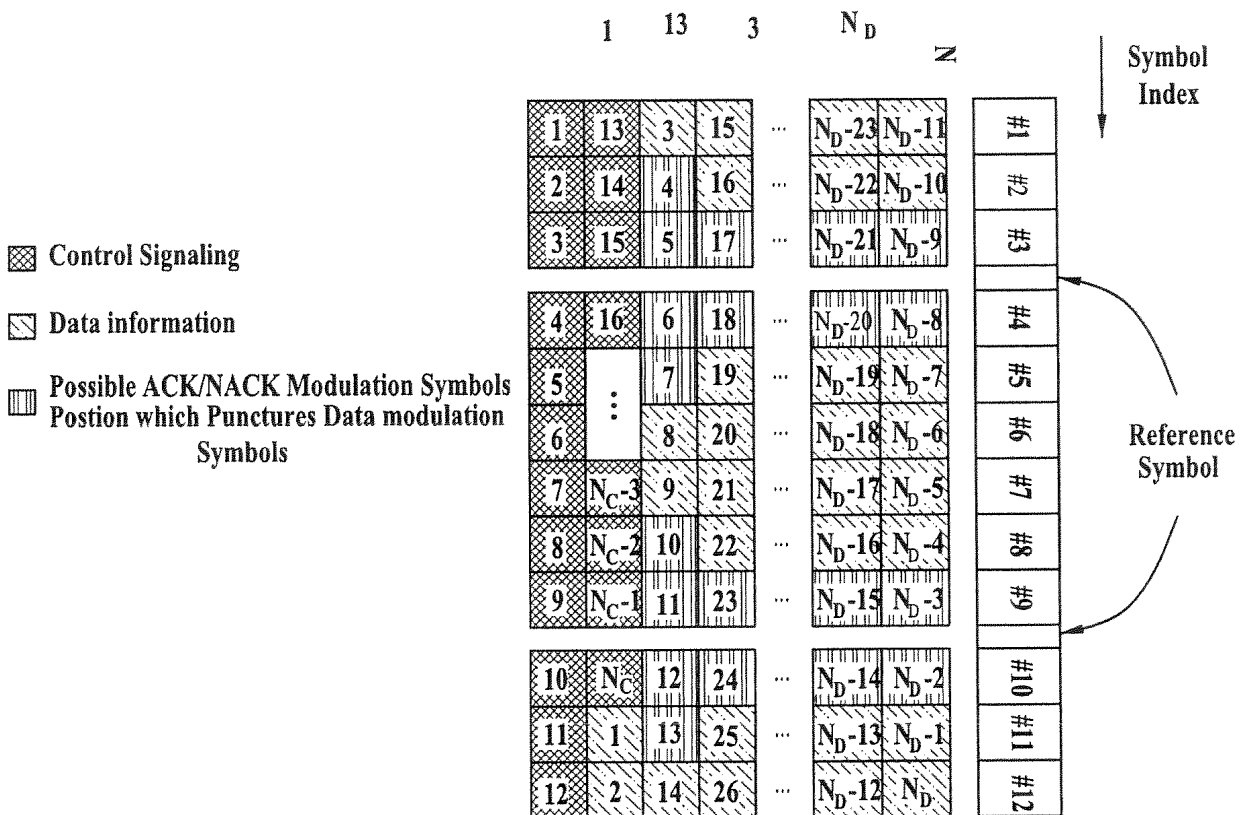

FIG. 8

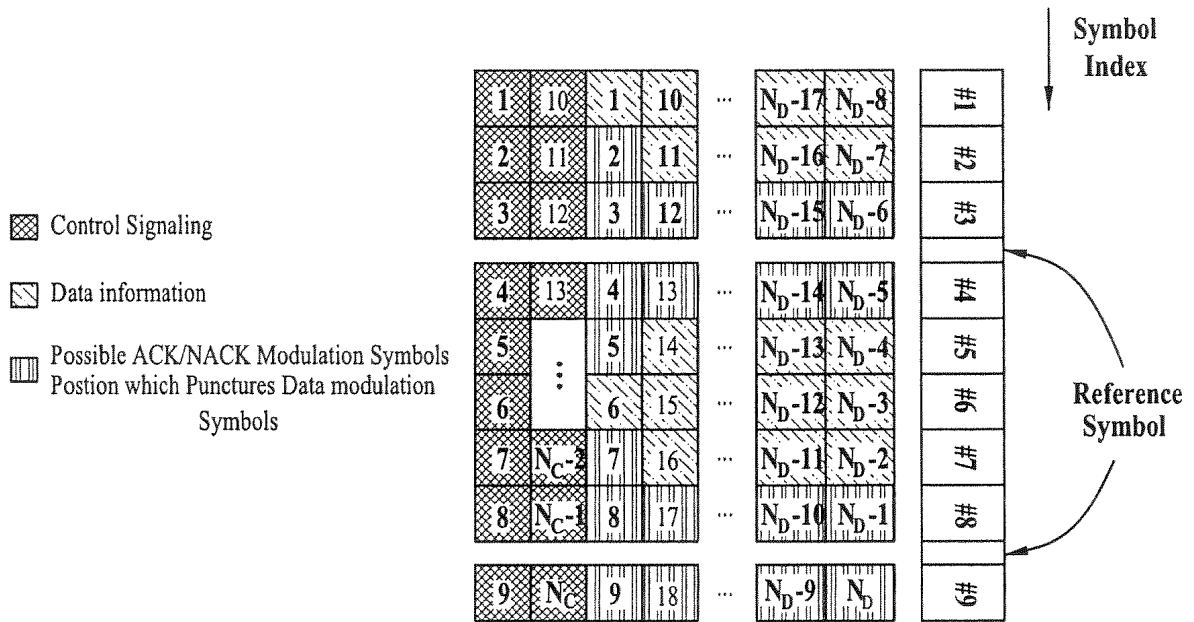
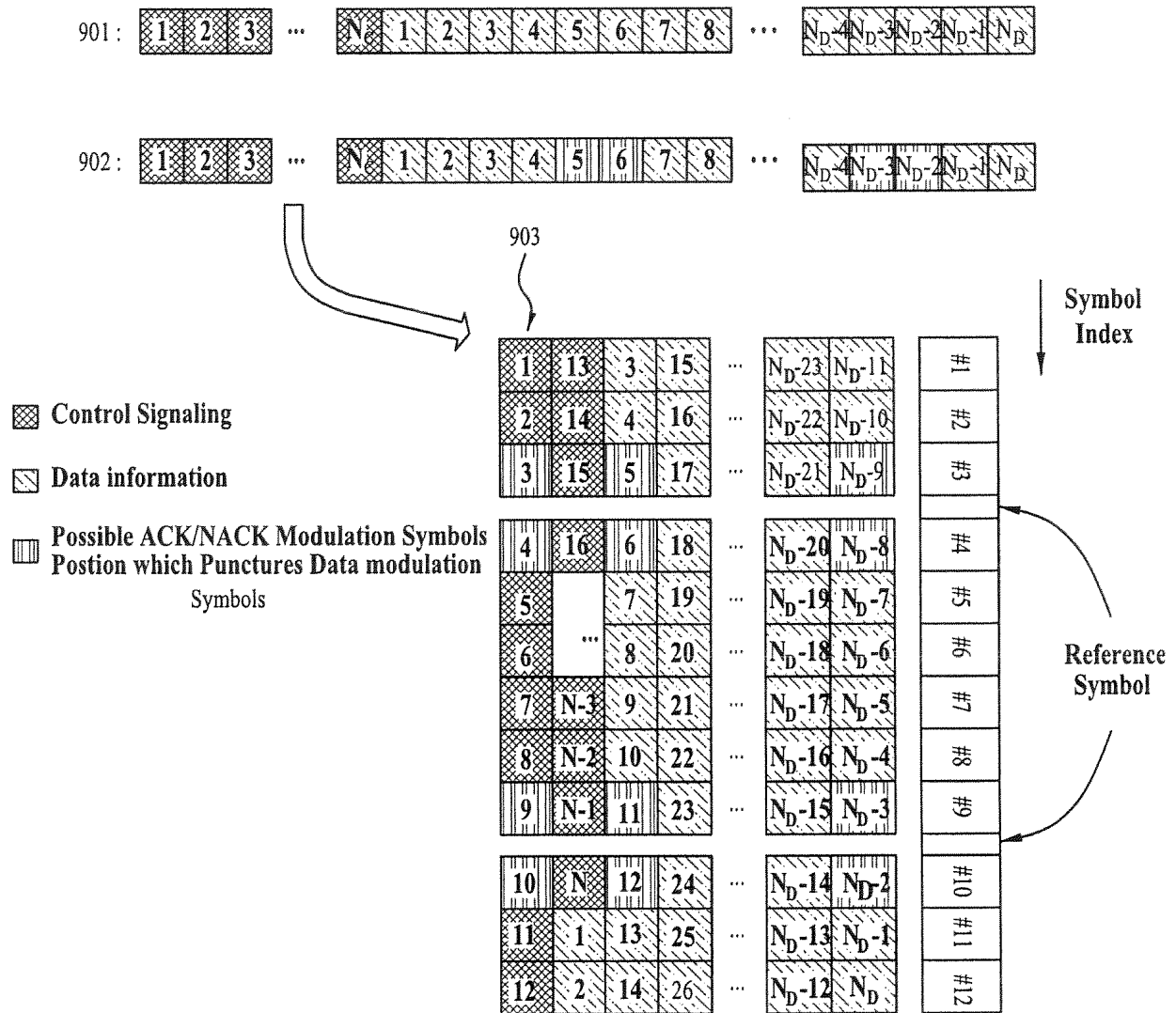



FIG. 9



## Electronic Patent Application Fee Transmittal

<b>Application Number:</b>	12209136			
<b>Filing Date:</b>	11-Sep-2008			
<b>Title of Invention:</b>	METHOD FOR TRANSMITTING UPLINK SIGNALS			
<b>First Named Inventor/Applicant Name:</b>	Dae Won Lee			
<b>Filer:</b>	Harry Sung Lee/Maggie Wen			
<b>Attorney Docket Number:</b>	2101-3573			
Filed as Large Entity				
<b>Utility under 35 USC 111(a) Filing Fees</b>				
<b>Description</b>	<b>Fee Code</b>	<b>Quantity</b>	<b>Amount</b>	<b>Sub-Total in USD(\$)</b>
<b>Basic Filing:</b>				
<b>Pages:</b>				
<b>Claims:</b>				
<b>Miscellaneous-Filing:</b>				
Late filing fee for oath or declaration	1051	1	130	130
<b>Petition:</b>				
<b>Patent-Appeals-and-Interference:</b>				
<b>Post-Allowance-and-Post-Issuance:</b>				
<b>Extension-of-Time:</b>				

Description	Fee Code	Quantity	Amount	Sub-Total in USD(\$)
Extension - 1 month with \$0 paid	1251	1	130	130
<b>Miscellaneous:</b>				
<b>Total in USD (\$)</b>				<b>260</b>

## Electronic Acknowledgement Receipt

<b>EFS ID:</b>	4523959
<b>Application Number:</b>	12209136
<b>International Application Number:</b>	
<b>Confirmation Number:</b>	3897
<b>Title of Invention:</b>	METHOD FOR TRANSMITTING UPLINK SIGNALS
<b>First Named Inventor/Applicant Name:</b>	Dae Won Lee
<b>Customer Number:</b>	35884
<b>Filer:</b>	Harry Sung Lee/Maggie Wen
<b>Filer Authorized By:</b>	Harry Sung Lee
<b>Attorney Docket Number:</b>	2101-3573
<b>Receipt Date:</b>	26-DEC-2008
<b>Filing Date:</b>	11-SEP-2008
<b>Time Stamp:</b>	20:44:40
<b>Application Type:</b>	Utility under 35 USC 111(a)

### Payment information:

Submitted with Payment	yes
Payment Type	Deposit Account
Payment was successfully received in RAM	\$260
RAM confirmation Number	5315
Deposit Account	502290
Authorized User	

The Director of the USPTO is hereby authorized to charge indicated fees and credit any overpayment as follows:

Charge any Additional Fees required under 37 C.F.R. Section 1.16 (National application filing, search, and examination fees)

Charge any Additional Fees required under 37 C.F.R. Section 1.17 (Patent application and reexamination processing fees)

**File Listing:**

Document Number	Document Description	File Name	File Size(Bytes)/ Message Digest	Multi Part /.zip	Pages (if appl.)
1	Miscellaneous Incoming Letter	TransmittalofMissingParts_2101-3573.pdf	58668 fd2c85afb1e07104f0eb4c1c7f0432b6cfb25074	no	1
<b>Warnings:</b>					
<b>Information:</b>					
2	Oath or Declaration filed	2101-3573_POA.pdf	525162 b791e047b442778cacb9ad351f606048ebb84bff	no	5
<b>Warnings:</b>					
<b>Information:</b>					
3	Drawings-only black and white line drawings	2101-3573_ReplacementDrawingsstoPTO.pdf	453712 5355d57768d86a5cf14feb7b72749d710533f75	no	7
<b>Warnings:</b>					
<b>Information:</b>					
4	Fee Worksheet (PTO-06)	fee-info.pdf	32252 327c89742b5342eee85ec9da4a73247628396503	no	2
<b>Warnings:</b>					
<b>Information:</b>					
<b>Total Files Size (in bytes):</b>			1069794		

This Acknowledgement Receipt evidences receipt on the noted date by the USPTO of the indicated documents, characterized by the applicant, and including page counts, where applicable. It serves as evidence of receipt similar to a Post Card, as described in MPEP 503.

**New Applications Under 35 U.S.C. 111**

If a new application is being filed and the application includes the necessary components for a filing date (see 37 CFR 1.53(b)-(d) and MPEP 506), a Filing Receipt (37 CFR 1.54) will be issued in due course and the date shown on this Acknowledgement Receipt will establish the filing date of the application.

**National Stage of an International Application under 35 U.S.C. 371**

If a timely submission to enter the national stage of an international application is compliant with the conditions of 35 U.S.C. 371 and other applicable requirements a Form PCT/DO/EO/903 indicating acceptance of the application as a national stage submission under 35 U.S.C. 371 will be issued in addition to the Filing Receipt, in due course.

**New International Application Filed with the USPTO as a Receiving Office**

If a new international application is being filed and the international application includes the necessary components for an international filing date (see PCT Article 11 and MPEP 1810), a Notification of the International Application Number and of the International Filing Date (Form PCT/RO/105) will be issued in due course, subject to prescriptions concerning national security, and the date shown on this Acknowledgement Receipt will establish the international filing date of the application.

## Electronic Acknowledgement Receipt

<b>EFS ID:</b>	4523959
<b>Application Number:</b>	12209136
<b>International Application Number:</b>	
<b>Confirmation Number:</b>	3897
<b>Title of Invention:</b>	METHOD FOR TRANSMITTING UPLINK SIGNALS
<b>First Named Inventor/Applicant Name:</b>	Dae Won Lee
<b>Customer Number:</b>	35884
<b>Filer:</b>	Harry Sung Lee/Maggie Wen
<b>Filer Authorized By:</b>	Harry Sung Lee
<b>Attorney Docket Number:</b>	2101-3573
<b>Receipt Date:</b>	26-DEC-2008
<b>Filing Date:</b>	11-SEP-2008
<b>Time Stamp:</b>	20:44:40
<b>Application Type:</b>	Utility under 35 USC 111(a)

### Payment information:

Submitted with Payment	yes
Payment Type	Deposit Account
Payment was successfully received in RAM	\$260
RAM confirmation Number	5315
Deposit Account	502290
Authorized User	

The Director of the USPTO is hereby authorized to charge indicated fees and credit any overpayment as follows:

Charge any Additional Fees required under 37 C.F.R. Section 1.16 (National application filing, search, and examination fees)

Charge any Additional Fees required under 37 C.F.R. Section 1.17 (Patent application and reexamination processing fees)

**File Listing:**

Document Number	Document Description	File Name	File Size(Bytes)/ Message Digest	Multi Part /.zip	Pages (if appl.)
1	Miscellaneous Incoming Letter	TransmittalofMissingParts_2101-3573.pdf	58668 fd2c85afb1e07104f0eb4c1c7f0432b6cfb25074	no	1
<b>Warnings:</b>					
<b>Information:</b>					
2	Oath or Declaration filed	2101-3573_POA.pdf	525162 b791e047b442778cacb9ad351f606048eb84bff	no	5
<b>Warnings:</b>					
<b>Information:</b>					
3	Drawings-only black and white line drawings	2101-3573_ReplacementDrawingsstoPTO.pdf	453712 5355d57768d86a5cf14feb7b72749d710533f75	no	7
<b>Warnings:</b>					
<b>Information:</b>					
4	Fee Worksheet (PTO-06)	fee-info.pdf	32252 327c89742b5342eee85ec9da4a73247628396503	no	2
<b>Warnings:</b>					
<b>Information:</b>					
<b>Total Files Size (in bytes):</b>			1069794		

This Acknowledgement Receipt evidences receipt on the noted date by the USPTO of the indicated documents, characterized by the applicant, and including page counts, where applicable. It serves as evidence of receipt similar to a Post Card, as described in MPEP 503.

**New Applications Under 35 U.S.C. 111**

If a new application is being filed and the application includes the necessary components for a filing date (see 37 CFR 1.53(b)-(d) and MPEP 506), a Filing Receipt (37 CFR 1.54) will be issued in due course and the date shown on this Acknowledgement Receipt will establish the filing date of the application.

**National Stage of an International Application under 35 U.S.C. 371**

If a timely submission to enter the national stage of an international application is compliant with the conditions of 35 U.S.C. 371 and other applicable requirements a Form PCT/DO/EO/903 indicating acceptance of the application as a national stage submission under 35 U.S.C. 371 will be issued in addition to the Filing Receipt, in due course.

**New International Application Filed with the USPTO as a Receiving Office**

If a new international application is being filed and the international application includes the necessary components for an international filing date (see PCT Article 11 and MPEP 1810), a Notification of the International Application Number and of the International Filing Date (Form PCT/RO/105) will be issued in due course, subject to prescriptions concerning national security, and the date shown on this Acknowledgement Receipt will establish the international filing date of the application.

**UNITED STATES PATENT AND TRADEMARK OFFICE**

UNITED STATES DEPARTMENT OF COMMERCE  
**United States Patent and Trademark Office**  
 Address: COMMISSIONER FOR PATENTS  
 P.O. Box 1450  
 Alexandria, Virginia 22313-1450  
 www.uspto.gov

APPLICATION NUMBER	FILING OR 371(C) DATE	FIRST NAMED APPLICANT	ATTY. DOCKET NO./TITLE
12/209,136	09/11/2008	Dae Won Lee	2101-3573

**CONFIRMATION NO. 3897**
**FORMALITIES LETTER**

35884  
 LEE, HONG, DEGERMAN, KANG & WAIMEY  
 660 S. FIGUEROA STREET  
 Suite 2300  
 LOS ANGELES, CA 90017

Date Mailed: 09/25/2008

**NOTICE TO FILE MISSING PARTS OF NONPROVISIONAL APPLICATION**
**FILED UNDER 37 CFR 1.53(b)**
*Filing Date Granted*
**Items Required To Avoid Abandonment:**

An application number and filing date have been accorded to this application. The item(s) indicated below, however, are missing. Applicant is given **TWO MONTHS** from the date of this Notice within which to file all required items and pay any fees required below to avoid abandonment. Extensions of time may be obtained by filing a petition accompanied by the extension fee under the provisions of 37 CFR 1.136(a).

- The oath or declaration is missing.  
*A properly signed oath or declaration in compliance with 37 CFR 1.63, identifying the application by the above Application Number and Filing Date, is required.*  
*Note: If a petition under 37 CFR 1.47 is being filed, an oath or declaration in compliance with 37 CFR 1.63 signed by all available joint inventors, or if no inventor is available by a party with sufficient proprietary interest, is required.*
- The above-identified nonprovisional application is claiming the benefit of a prior-filed provisional application that is in a non-English language. Pursuant to 37 CFR 1.78(a)(5)(iv), applicant is required to file:
  1. In the prior-filed provisional application, an English language translation of the prior-filed provisional application and a statement that the translation is accurate; and
  2. In the above-identified nonprovisional application, a confirmation that the translation and statement have been filed in the prior-filed provisional application.

To avoid abandonment of the above-identified nonprovisional application, applicant is required to file these items within the time period set forth in this notice, unless applicant files an amendment or a Supplemental Application Data Sheet, whichever is appropriate, to delete the benefit claim within the time period. Please note that once applicant deletes the benefit claim to the prior-filed provisional application, the Office will not accept any resubmission of the benefit claim.

The application is informal since it does not comply with the regulations for the reason(s) indicated below.

The required item(s) identified below must be timely submitted to avoid abandonment:

- Replacement drawings in compliance with 37 CFR 1.84 and 37 CFR 1.121(d) are required. The drawings submitted are not acceptable because:



- The drawings submitted to the Office are not electronically reproducible because portions of figures 3-9 are missing and/or blurry.

Applicant is cautioned that correction of the above items may cause the specification and drawings page count to exceed 100 pages. If the specification and drawings exceed 100 pages, applicant will need to submit the required application size fee.

The applicant needs to satisfy supplemental fees problems indicated below.

The required item(s) identified below must be timely submitted to avoid abandonment:

- To avoid abandonment, a surcharge (for late submission of filing fee, search fee, examination fee or oath or declaration) as set forth in 37 CFR 1.16(f) of **\$130** for a non-small entity, must be submitted with the missing items identified in this notice.

**SUMMARY OF FEES DUE:**

Total additional fee(s) required for this application is **\$130** for a non-small entity

- **\$130** Surcharge.

Replies should be mailed to:

Mail Stop Missing Parts  
Commissioner for Patents  
P.O. Box 1450  
Alexandria VA 22313-1450

Registered users of EFS-Web may alternatively submit their reply to this notice via EFS-Web.

<https://sportal.uspto.gov/authenticate/AuthenticateUserLocalEPF.html>

For more information about EFS-Web please call the USPTO Electronic Business Center at **1-866-217-9197** or visit our website at <http://www.uspto.gov/ebc>.

If you are not using EFS-Web to submit your reply, you must include a copy of this notice.

/rerry/

---

Office of Data Management, Application Assistance Unit (571) 272-4000, or (571) 272-4200, or 1-888-786-0101



## UNITED STATES PATENT AND TRADEMARK OFFICE

UNITED STATES DEPARTMENT OF COMMERCE  
 United States Patent and Trademark Office  
 Address: COMMISSIONER FOR PATENTS  
 P.O. Box 1450  
 Alexandria, Virginia 22313-1450  
 www.uspto.gov

APPLICATION NUMBER	FILING or 371(c) DATE	GRP ART UNIT	FIL FEE REC'D	ATTY. DOCKET NO	TOT CLAIMS	IND CLAIMS
12/209,136	09/11/2008	2617	1400	2101-3573	8	2

CONFIRMATION NO. 3897

## FILING RECEIPT



35884  
 LEE, HONG, DEGERMAN, KANG & WAIMEY  
 660 S. FIGUEROA STREET  
 Suite 2300  
 LOS ANGELES, CA 90017

Date Mailed: 09/25/2008

Receipt is acknowledged of this non-provisional patent application. The application will be taken up for examination in due course. Applicant will be notified as to the results of the examination. Any correspondence concerning the application must include the following identification information: the U.S. APPLICATION NUMBER, FILING DATE, NAME OF APPLICANT, and TITLE OF INVENTION. Fees transmitted by check or draft are subject to collection. Please verify the accuracy of the data presented on this receipt. **If an error is noted on this Filing Receipt, please submit a written request for a Filing Receipt Correction. Please provide a copy of this Filing Receipt with the changes noted thereon. If you received a "Notice to File Missing Parts" for this application, please submit any corrections to this Filing Receipt with your reply to the Notice. When the USPTO processes the reply to the Notice, the USPTO will generate another Filing Receipt incorporating the requested corrections**

**Applicant(s)**

Dae Won Lee, Residence Not Provided;  
 Bong Hoe Kim, Residence Not Provided;  
 Young Woo Yun, Residence Not Provided;  
 Ki Jun Kim, Residence Not Provided;  
 Dong Wook Roh, Residence Not Provided;  
 Hak Seong Kim, Residence Not Provided;  
 Hyun Wook Park, Residence Not Provided;

**Assignment For Published Patent Application**

LG Electronics Inc.

**Power of Attorney:** None**Domestic Priority data as claimed by applicant**

This appln claims benefit of 60/972,244 09/13/2007  
 and claims benefit of 60/987,427 11/13/2007  
 and claims benefit of 60/988,433 11/16/2007

**Foreign Applications**

REPUBLIC OF KOREA 10-2008-0068634 07/15/2008

**If Required, Foreign Filing License Granted:** 09/24/2008

The country code and number of your priority application, to be used for filing abroad under the Paris Convention, is **US 12/209,136**

**Projected Publication Date:** To Be Determined - pending completion of Missing Parts

**Non-Publication Request:** No

**Early Publication Request:** No  
**Title**

METHOD FOR TRANSMITTING UPLINK SIGNALS

**Preliminary Class**

370

## **PROTECTING YOUR INVENTION OUTSIDE THE UNITED STATES**

Since the rights granted by a U.S. patent extend only throughout the territory of the United States and have no effect in a foreign country, an inventor who wishes patent protection in another country must apply for a patent in a specific country or in regional patent offices. Applicants may wish to consider the filing of an international application under the Patent Cooperation Treaty (PCT). An international (PCT) application generally has the same effect as a regular national patent application in each PCT-member country. The PCT process **simplifies** the filing of patent applications on the same invention in member countries, but **does not result** in a grant of "an international patent" and does not eliminate the need of applicants to file additional documents and fees in countries where patent protection is desired.

Almost every country has its own patent law, and a person desiring a patent in a particular country must make an application for patent in that country in accordance with its particular laws. Since the laws of many countries differ in various respects from the patent law of the United States, applicants are advised to seek guidance from specific foreign countries to ensure that patent rights are not lost prematurely.

Applicants also are advised that in the case of inventions made in the United States, the Director of the USPTO must issue a license before applicants can apply for a patent in a foreign country. The filing of a U.S. patent application serves as a request for a foreign filing license. The application's filing receipt contains further information and guidance as to the status of applicant's license for foreign filing.

Applicants may wish to consult the USPTO booklet, "General Information Concerning Patents" (specifically, the section entitled "Treaties and Foreign Patents") for more information on timeframes and deadlines for filing foreign patent applications. The guide is available either by contacting the USPTO Contact Center at 800-786-9199, or it can be viewed on the USPTO website at <http://www.uspto.gov/web/offices/pac/doc/general/index.html>.

For information on preventing theft of your intellectual property (patents, trademarks and copyrights), you may wish to consult the U.S. Government website, <http://www.stopfakes.gov>. Part of a Department of Commerce initiative, this website includes self-help "toolkits" giving innovators guidance on how to protect intellectual property in specific countries such as China, Korea and Mexico. For questions regarding patent enforcement issues, applicants may call the U.S. Government hotline at 1-866-999-HALT (1-866-999-4158).

### **LICENSE FOR FOREIGN FILING UNDER**

**Title 35, United States Code, Section 184**

**Title 37, Code of Federal Regulations, 5.11 & 5.15**

### **GRANTED**

The applicant has been granted a license under 35 U.S.C. 184, if the phrase "IF REQUIRED, FOREIGN FILING LICENSE GRANTED" followed by a date appears on this form. Such licenses are issued in all applications where

the conditions for issuance of a license have been met, regardless of whether or not a license may be required as set forth in 37 CFR 5.15. The scope and limitations of this license are set forth in 37 CFR 5.15(a) unless an earlier license has been issued under 37 CFR 5.15(b). The license is subject to revocation upon written notification. The date indicated is the effective date of the license, unless an earlier license of similar scope has been granted under 37 CFR 5.13 or 5.14.

This license is to be retained by the licensee and may be used at any time on or after the effective date thereof unless it is revoked. This license is automatically transferred to any related applications(s) filed under 37 CFR 1.53(d). This license is not retroactive.

The grant of a license does not in any way lessen the responsibility of a licensee for the security of the subject matter as imposed by any Government contract or the provisions of existing laws relating to espionage and the national security or the export of technical data. Licensees should apprise themselves of current regulations especially with respect to certain countries, of other agencies, particularly the Office of Defense Trade Controls, Department of State (with respect to Arms, Munitions and Implements of War (22 CFR 121-128)); the Bureau of Industry and Security, Department of Commerce (15 CFR parts 730-774); the Office of Foreign Assets Control, Department of Treasury (31 CFR Parts 500+) and the Department of Energy.

**NOT GRANTED**

No license under 35 U.S.C. 184 has been granted at this time, if the phrase "IF REQUIRED, FOREIGN FILING LICENSE GRANTED" DOES NOT appear on this form. Applicant may still petition for a license under 37 CFR 5.12, if a license is desired before the expiration of 6 months from the filing date of the application. If 6 months has lapsed from the filing date of this application and the licensee has not received any indication of a secrecy order under 35 U.S.C. 181, the licensee may foreign file the application pursuant to 37 CFR 5.15(b).

FORM PTO-1082

PATENT DOCKET NO. 2101-3573  
CUSTOMER NO. 035884

## IN THE UNITED STATES PATENT AND TRADEMARK OFFICE

In re application of:

Dae Won LEE, Bong Hoe KIM, Young Woo YUN, Ki Jun KIM,  
Dong Wook ROH, Hak Seong KIM and Hyun Wook PARK

Art Unit:

Examiner:

Serial No:

Filed: Herewith

For: METHOD FOR TRANSMITTING UPLINK SIGNALS

Commissioner for Patents  
P.O. Box 1450  
Alexandria, VA 22313-1450

Dear Sir:

Transmitted herewith for filing is the patent application identified above.

- 9 sheet(s) of drawings ( formal  informal) is(are) enclosed.
- 26 page(s) of specification and 1 page(s) of abstract of the invention are enclosed.
- An assignment of the invention to LG Electronics Inc.  is enclosed  will follow.
- Declaration and Power of Attorney  is enclosed  will follow.
- A certified copy of Korean Patent Application No. 10-2008-0068634 filed on July 15, 2008, from which priority is claimed in the subject case pursuant to 35 U.S.C. § 119  will follow  is/are enclosed.

CALCULATION OF FEES									
ITEM		TOTAL NO. OF CLAIMS		NO. OF CLAIMS OVER BASE	LG/SM \$ ENTITY FEE		\$ AMOUNT	\$ FEE	
A	TOTAL CLAIMS FEE	12	-20	0	LG=\$50 SM=\$25	\$ 50	\$ 0	\$ 0	
B	INDEPENDENT CLAIMS FEE*	2	-3	0	LG=\$210 SM=\$100	\$ 210	\$ 0	\$ 0	
C	SUBTOTAL - ADDITIONAL CLAIMS FEE (ADD FINAL COLUMN IN LINES A + B)							\$ 0	
D	MULTIPLE-DEPENDENT CLAIMS FEE					LARGE ENTITY FEE = \$370 SMALL ENTITY FEE = \$180		\$ 370	
E	BASIC FILING FEE					LARGE ENTITY FEE = \$310 SMALL ENTITY FEE = \$150		\$ 310	
F	SEARCH FEE					LARGE ENTITY FEE = \$510 SMALL ENTITY FEE = \$250		\$ 510	
G	EXAMINATION FEE					LARGE ENTITY FEE = \$210 SMALL ENTITY FEE = \$100		\$ 210	
H	APPLICATION SIZE FEE (If the specification and drawings exceed 100 sheets of paper, for each additional 50 sheets or fraction thereof.)					LARGE ENTITY FEE = \$260 SMALL ENTITY FEE = \$125		\$ 0	
I	TOTAL FILING FEE (ADD TOTALS FOR LINES C, D, E, F, G AND H)							\$ 1,400	
J	ASSIGNMENT RECORDING FEE							\$ 40	\$ 0
	*LIST INDEPENDENT CLAIMS [1, 7, 9 and 10]								

- The Commissioner is hereby authorized to charge any deficiency for the following fees associated with this communication or credit any overpayment to Deposit Account No. 502290. A copy of this sheet is enclosed.
  - The amount of \$ 1,400 for the total filing fee.
  - Any additional filing fees required under 37 C.F.R. § 1.16
  - Any patent application processing fees under 37 C.F.R. § 1.17

Respectfully submitted,

LEE, HONG, DEGERMAN, KANG & SCHMADEKA

Date: September 11, 2008

By:   
\_\_\_\_\_  
Harry S. Lee  
Registration No. 56,814

Customer No. 35884

UNITED STATES PATENT APPLICATION

OF

[Dae Won LEE, Bong Hoe KIM, Young Woo YUN, Ki Jun KIM,  
Dong Wook ROH, Hak Seong KIM and Hyun Wook PARK]

FOR

METHOD FOR TRANSMITTING UPLINK SIGNALS

**CROSS-REFERENCE TO RELATED APPLICATIONS**

[0001] This application claims the benefit of the Korean Patent Application No. 10-2008-0068634, filed on July 15, 2008, which is hereby incorporated by reference as if fully set forth herein.

[0002] This application also claims the benefit of U.S. Provisional Application Serial Nos. 60/972,244, filed on September 13, 2007, 60/987,427, filed on November 13, 2007 and 60/988,433, filed on November 16, 2007, the contents of which are hereby incorporated by reference herein in their entirety.

**BACKGROUND OF THE INVENTION****Field of the Invention**

The present invention relates to mobile communication technology, and more particularly, to technology of transmitting uplink signals including ACK/NACK signals, control signals other than the ACK/NACK signals, and data signals.

**Discussion of the Related Art**

A user equipment (UE) of a mobile communication system transmits various signals through an uplink. Uplink signals transmitted by the user equipment can be segmented into data



signals and control signals. Also, examples of the control signals transmitted to the uplink include uplink ACK/NACK signals for HARQ communication, channel quality indicator (CQI) information, and precoding matrix index (PMI).

3GPP LTE system uses a single carrier frequency division multiplexing access (SC-FDMA) scheme for uplink signal transmission. Also, the 3GPP LTE system prescribes that data signals and control signals among the uplink signals are first multiplexed and ACK/NACK signals are transmitted to the multiplexed signals by puncturing the data or control signals when uplink ACK/NACK signal transmission is required for downlink data. Hereinafter, in order that the ACK/NACK signals are divided from control signals other than the ACK/NACK signals, the control signals will mean those except for the ACK/NACK signals.

Meanwhile, Athens conference (#50) for 3GPP LTE has decided that data information is rate matched together with control information when the control information is multiplexed with the data information, wherein the control information is transmitted near a reference signal. This is to improve channel estimation performance by approximating all the control signals to the reference signal as the control signals generally require higher reliability than the data signals.

However, the control signals transmitted to the uplink

include various signals as described above, and the ACK/NACK signals require higher reliability than the other control signals. In this case, when uplink ACK/NACK signal transmission is required while all the control signals are transmitted by approximating to the reference signal, problems occur in that the ACK/NACK signals can neither be transmitted by puncturing the control signals arranged near the reference signal nor be transmitted near the reference signal.

In this respect, a technology of transmitting uplink signals by efficiently arranging ACK/NACK signals and other control signals in a resource region considering priority among them is required.

#### SUMMARY OF THE INVENTION

Accordingly, the present invention is directed to a method for transmitting uplink signals, which substantially obviates one or more problems due to limitations and disadvantages of the related art.

An object of the present invention is to provide a method for transmitting uplink signals by efficiently arranging ACK/NACK signals and other control signals in a resource region considering priority among them.

Another object of the present invention is to provide transmitting uplink signals using the aforementioned signal

arrangement.

To achieve these objects and other advantages and in accordance with the purpose of the invention, as embodied and broadly described herein, the present invention provides a method for transmitting uplink signals, which include ACK/NACK signals, control signals other than the ACK/NACK signals, and data signals. The method comprises serially multiplexing the control signals and the data signals; sequentially mapping the multiplexed signals within a specific resource region in accordance with a time-first mapping method, the specific resource region including a plurality of symbols and a plurality of virtual subcarriers; and arranging the ACK/NACK signals at both symbols near to symbols through which a reference signal is transmitted.

At this time, the ACK/NACK signals are overwritten on a part of the multiplexed signals. And, the part of the multiplexed signals, on which the ACK/NACK signals are overwritten, includes one or more of the control signals and the data signals.

Also, the method further comprises performing a discrete fourier transform (DFT) for the signals mapped on the specific resource region in a unit of each symbols of the plurality of symbols in accordance with each index of the plurality of virtual subcarriers; performing an inverse fast fourier transform (IFFT) for the DFT symbol unit signals and attaching

a cyclic prefix (CP) the signals; and transmitting the symbol unit signals attached with the CP as single carrier frequency division multiplexing access (SC-FDMA) symbols.

Also, the method further comprises transmitting the signals mapped on the specific resource region through a physical uplink sharing channel (PUSCH).

In another aspect of the present invention, the present invention provides a method for transmitting uplink signals, which include ACK/NACK signals, control signals other than the ACK/NACK signals, and data signals. The method comprises performing channel coding for each of the data signals, the control signals, and the ACK/NACK signals; serially multiplexing the channel coded data and control signals; sequentially mapping the multiplexed signals in accordance with a time-first mapping method within a specific resource region in accordance with a time-first mapping method, the specific resource region including a plurality of symbols and a plurality of virtual subcarriers; and arranging the ACK/NACK signals at both symbols near to the symbols through which a reference signal is transmitted.

At this time, the step of performing channel coding for the data signals includes attaching a CRC for a transport block (TB) to a transport block for transmission of the data signals; segmenting the transport block attached with the CRC for the transport block in a code block unit and attaching a

CRC for a code block to the segmented code block; performing channel coding for the data attached with the CRC for a code block; and performing rate matching and code block concatenation for the channel coded data.

According to the aforementioned embodiments of the present invention, it is possible to transmit uplink signals by efficiently arranging ACK/NACK signals and other control signals in a resource region in accordance with priority among them.

In addition, the ACK/NACK signals having high priority can be set in such a manner that they acquire more channel estimation effect.

#### **BRIEF DESCRIPTION OF THE DRAWINGS**

The accompanying drawings, which are included to provide a further understanding of the invention and are incorporated in and constitute a part of this specification, illustrate embodiments of the invention and together with the description serve to explain the principles of the invention.

In the drawings:

FIG. 1 is a block diagram illustrating a transmitter to describe a method for transmitting signals in accordance with a single carrier frequency division multiplexing access (SC-

FDMA) scheme;

FIG. 2 is a diagram illustrating a procedure of multiplexing data information, control information and ACK/NACK signals for uplink signal transmission;

FIG. 3 is a diagram illustrating an example of mapping information sequences according to one embodiment of the present invention in accordance with a time-first mapping method

FIG. 4 and FIG. 5 are diagrams illustrating a method for transmitting information, which is mapped in accordance with the time-first mapping method as illustrated in FIG. 3, in accordance with the SC-FDMA scheme;

FIG. 6 is a diagram illustrating a method for transmitting uplink signals in accordance with one embodiment of the present invention;

FIG. 7 and FIG. 8 are diagrams illustrating a method for processing a number of ACK/NACK information data to be transmitted in accordance with one embodiment of the present invention; and

FIG. 9 is a diagram illustrating that ACK/NACK signals are inserted by puncturing the control signals as well as the data signals in accordance with another embodiment of the present invention.

**DETAILED DESCRIPTION OF THE INVENTION**

Hereinafter, the preferred embodiments of the present invention will be described with reference to the accompanying drawings. It is to be understood that the detailed description, which will be disclosed along with the accompanying drawings, is intended to describe the exemplary embodiments of the present invention, and is not intended to describe a unique embodiment with which the present invention can be carried out. Hereinafter, the following detailed description includes detailed matters to provide full understanding of the present invention. However, it will be apparent to those skilled in the art that the present invention can be carried out without the detailed matters.

Meanwhile, in some cases, to prevent the concept of the present invention from being ambiguous, structures and apparatuses of the known art will be omitted, or will be shown in the form of a block diagram based on main functions of each structure and apparatus. Also, wherever possible, the same reference numbers will be used throughout the drawings and the specification to refer to the same or like parts.

As described above, the embodiment of the present invention is intended to provide a method for transmitting uplink signals by efficiently arranging ACK/NACK signals and

other control signals in a resource region considering priority among them. To this end, a detailed method for transmitting uplink signals in a 3GPP LTE system will be described.

FIG. 1 is a block diagram illustrating a transmitter to describe a method for transmitting signals in accordance with a single carrier frequency division multiplexing access (SC-FDMA) scheme.

As described above, a 3GPP LTE system transmits uplink signals in accordance with a single carrier frequency division multiplexing access (SC-FDMA) scheme. In detail, direct-to-parallel conversion is performed for information sequences to be transmitted, to perform a discrete fourier transform (DFT) (101). The DFT is performed for the signals converted to the parallel sequences (102), and then inverse fast fourier transform (IFFT) can be performed to obtain a single carrier feature (103). At this time, a length of information inserted to an IFFT module 103 may not be equal to a size of the IFFT module 103. However, it is required that the DFT result performed by the DFT module 102 should be mapped with continuous IFFT input indexes.

Values undergone IFFT are again converted to serial signals by a parallel-to-serial conversion module 104. Afterwards, the signals are changed to a format of OFDM symbols by a cyclic prefix (CP) (105) and then transmitted to



a real time space.

The aforementioned SC-FDMA scheme has advantages in that it has low peak power-to-average power ratio (PAPR) and/or cubic metric (CM) while maintaining a single carrier feature. However, in order to satisfy low PAPR/CM condition while maintaining a single carrier feature, it is required that information undergone DFT precoding should be input to the IFFT module 103 in an OFDM format by mapping with continuous indexes. In other words, it is required that DFT precoded information should be inserted to continuous subcarriers of OFDM. Accordingly, it is preferable that information data (for example, control information and data information) having different features are multiplexed together when they are transmitted to an uplink so that they undergo DFT precoding together and then are transmitted in an OFDM format.

Hereinafter, a procedure of multiplexing data information and control information will be described.

FIG. 2 is a diagram illustrating a procedure of multiplexing data information, control information and ACK/NACK signals for uplink signal transmission.

Data information multiplexed with control information is segmented into several code blocks (CB) in accordance with a size of a transport block (TB) to be transmitted to the uplink after CRC for TB is attached to the TB (S201 and S202). Afterwards, the CRC for CB is attached to several CBs (S203),

and channel coding is performed for the result value obtained by attaching the CRC for CB to several CBs (S204). Also, after the channel coded data undergo rate matching (S205), concatenation among CBs is performed (S206). The CBs are then multiplexed with control information (S230). Meanwhile, the aforementioned steps may be subject to channel coding chain for a data transport block.

Channel coding can be performed for the control information separately from the data information (S211). The channel coded control information can later be multiplexed with the data information by a data and control channel rate mapping multiplexer (S230).

Channel coding can be performed for the ACK/NACK signals separately from the data and control signals (S221). Some of the uplink signals in which the data and control signals are multiplexed (S230) may be transmitted to the uplink through puncturing (S240).

As described above, the control information that can be transmitted together with the data information is segmented into two types, i.e., uplink (UL) ACK/NACK signals for downlink data and other control information. The uplink ACK/NACK signals for downlink data are transmitted only when downlink data exist. A user equipment may not know whether to receive downlink data even though it should transmit the UL ACK/NACK signals. Accordingly, the user equipment segments the

two types of control information from each other and transmits them to the uplink together with the data information. Hereinafter, in order to segment the ACK/NACK signals from the control signals transmitted separately from the ACK/NACK signals, "control signals" will mean those other than the ACK/NACK signals. In more detailed embodiment, the control signals may mean those other than a rank indicator as well as the ACK/NACK signals. In other words, in a specific embodiment, the control signals may include CQI and PMI. However, since the following description relates to efficient arrangement among the control signals, the data signals and the ACK/NACK signals, if the control signals are those other than the ACK/NACK signals, their detailed type will not be suggested.

When the data information is transmitted to the uplink, the data information can be transmitted together with the control information. Also, ACK/NACK information can be transmitted together with the data information and the control information. Moreover, only the data information and the ACK/NACK information can be transmitted to the uplink.

Transmission information sequences obtained to transmit the data information multiplexed with the control information or the ACK/NACK information can be transmitted in accordance with the SC-FDMA scheme. At this time, the transmission information sequences can be mapped in a resource region in accordance with a time-first mapping method.

For example, it is supposed that the information sequences are transmitted using one resource block, i.e., twelve (12) OFDM subcarriers and information is transmitted through one sub-frame. Also, it is supposed that one sub-frame includes fourteen (14) SC-FDMA symbols and two of the fourteen SC-FDMS symbols are used as references signals that are pilot signals. At this time, the number of modulation symbols of the information that can be transmitted to the uplink becomes  $12 \times 12 = 144$ .

144 information sequence symbols can be transmitted through 12 virtual subcarriers and 12 SC-FDMA symbols. This can be represented by a matrix structure of  $12 \times 12$  called a time-frequency mapper. The information sequences to be transmitted to the uplink are mapped one by one based on the SC-FDMA symbols. This is called time-first mapping because the SC-FDMA symbols are segmented temporally.

FIG. 3 is a diagram illustrating an example of mapping information sequences according to one embodiment of the present invention in accordance with a time-first mapping method, and FIG. 4 and FIG. 5 are diagrams illustrating a method for transmitting information, which is mapped in accordance with the time-first mapping method as illustrated in FIG. 3, in accordance with the SC-FDMA scheme.

The information sequences to be transmitted to the uplink can be arranged temporally in the time-frequency mapper

as illustrated in FIG. 3. In other words, 12 information data are mapped temporally in a first virtual subcarrier region, and then subsequent 12 information data are mapped temporally in a second virtual subcarrier region.

After time-frequency mapping is performed as above, the sequences arranged on a frequency axis as illustrated in FIG. 4 and FIG. 5 undergo DFT and then are inserted to a desired frequency band. Afterwards, IFFT and CP insertion are performed for each frequency region information, which can be transmitted as SC-FDMA symbols. FIG. 4 and FIG. 5 illustrate a procedure of generating and transmitting the SC-FDMA symbols. FIG. 4 illustrates a case where a normal CP is used, and FIG. 5 illustrates a case where an extended CP is used.

When data are transmitted to the uplink, the control information can also be transmitted thereto. At this time, the control information and the data information are multiplexed through rate matching. However, the ACK/NACK information can be transmitted in such a manner that it is overwritten in bit streams of the data information or symbols where data information and control information are multiplexed. In this case, "overwritten" means that specific information mapped in the resource region is skipped and the corresponding region is mapped. Also, "overwritten" means that the length of the entire information is maintained equally even after specific information is inserted. This overwriting procedure may be

represented by puncturing.

Generally, the control information requires higher reliability than the data information. To this end, the control information should be multiplexed or inserted near the reference signal. In this case, it is possible to obtain the effect of channel estimation performance, thereby expecting improvement of performance.

However, since the ACK/NACK information also requires high reliability in a receiver, if the general control information is arranged near the reference signal, priority between the control information and the ACK/NACK signals should be considered.

Accordingly, methods for multiplexing data information bit streams, control information bit streams, and ACK/NACK information sequences at different priorities will be described as various embodiments of the present invention.

According to one embodiment of the present invention, the control information is multiplexed serially with the data information, and is mapped with a multiplexing region in accordance with the aforementioned time-first mapping method. In this case, "multiplexed serially" means that the data information is mapped with a sequence corresponding to the multiplexed result directly after the control information is mapped with the sequence, or vice versa. Also, according to one embodiment of the present invention, the ACK/NACK signals

are arranged to be transmitted through both symbols near a symbol through which the reference signal is transmitted.

FIG. 6 is a diagram illustrating a method for transmitting uplink signals in accordance with one embodiment of the present invention.

According to this embodiment, when the control information and the data information are multiplexed, they are serially connected with each other so that they are mapped with SC-FDMS symbols in accordance with the time-first mapping method and then are transmitted to the uplink. If the ACK/NACK information should also be transmitted, among the serially multiplexed data, modulation symbols located near the reference signal are punctured so that the ACK/NACK signals are inserted thereto. In FIG. 6, a reference numeral 601 illustrates that the data and control signals are multiplexed serially if the ACK/NACK signals are not transmitted. A reference numeral 602 illustrates that the ACK/NACK signals are arranged by puncturing the multiplexed data if the ACK/NACK signals should be transmitted to the uplink. Also, a reference numeral 603 illustrates that information sequences such as the reference numeral 602 are mapped in the time-frequency region in accordance with the time-first mapping method. In the reference numeral 603 of FIG. 6, it is supposed that the reference signal is transmitted through a part between symbol indexes #3 and #4 and a part between symbol

indexes #9 and #10.

As can be aware of it from the mapping type illustrated in the reference numeral 603 of FIG. 6, after the control signals are serially connected with data and then multiplexed, they are mapped in the time-frequency region in accordance with the time-first mapping method. Also, the ACK/NACK signals can be set in such a manner that they are overwritten in the data signals multiplexed with two symbols (symbols #3, 4, 9 and 10 in FIG. 6) at both sides of the SC-FDMA symbols to which the reference signal is transmitted.

FIG. 7 and FIG. 8 are diagrams illustrating a method for processing a number of ACK/NACK information data to be transmitted in accordance with one embodiment of the present invention.

In detail, when the number of ACK/NACK information data to be transmitted is more than the number of subcarriers (of a virtual frequency region) to which data are transmitted before and after the reference signal, the ACK/NACK information can be transmitted through additional SC-FDMA symbols in addition to both symbols nearest to the reference signal. In FIG. 7 and FIG. 8, the ACK/NACK information is transmitted through additional symbols in the order of the symbols near reference symbols in addition to both symbols near the reference symbols.

At this time, the SC-FDMA symbols existing based on the reference signal may not be arranged symmetrically depending



on a structure of the SC-FDMA sub-frame of the uplink as illustrated in FIG. 8. Accordingly, considering this, the ACK/NACK information should be inserted by puncturing.

When the control information is arranged on the time-axis in accordance with the aforementioned embodiment of the present invention, the control information and the data information are arranged in due order so that they are mapped in the resource region. Also, if the ACK/NACK information is arranged near the reference signal, the ACK/NACK information can be overwritten in the control information as well as the data information.

FIG. 9 is a diagram illustrating that the ACK/NACK signals are inserted by puncturing the control signals as well as the data signals in accordance with another embodiment of the present invention.

According to this embodiment, since the ACK/NACK information is substantially control information, priority is given to control information channels, so that the control information channel having the highest priority is arranged near the reference signal for protection of channel estimation while the control information channels having relatively low priority are sequentially mapped on the time axis and then transmitted. Particularly, in this embodiment, it is supposed that the ACK/NACK information has higher priority than the control information. At this time, the control information and

the data information are sequentially arranged on the time axis in accordance with the time-first mapping method and then multiplexed. The ACK/NACK information punctures the data/control information located near the reference signal.

In detail, a reference numeral 901 of FIG. 9 illustrates that the data and control signals are multiplexed if the ACK/NACK signals need not to be transmitted. A reference numeral 902 of FIG. 9 illustrates that data, control signals and ACK/NACK signals are multiplexed if the ACK/NACK signals should be transmitted. Also, a reference numeral 903 of FIG. 9 illustrates that the multiplexed uplink signals are mapped in the time-frequency region as illustrated in the reference numeral 902.

As illustrated in the reference numeral 903 of FIG. 9, it is noted from this embodiment that the ACK/NACK signals can puncture the control signals as well as the data matched near the reference signal. In this way, if resource mapping is performed by giving priority to the control signals, good channel estimation effect can be obtained as the ACK/NACK information is located near the reference signal. On the other hand, since a small number of control signals are punctured by the ACK/NACK signals, it may not affect performance. In one embodiment shown in FIG. 9, the ACK/NACK signals may puncture the control signals/data equally distributed in the virtual frequency axis. That is, if the number of virtual subcarriers

available for the above puncturing by the ACK/NACK signals is "N" and the number of ACK/NACK to be transmitted per SC-FDMA symbol is "m", the ACK/NACK signals may puncture the control signals/data equally distributed having the interval of "N/m" or equivalent.

Also, since the control information and the data information are multiplexed simply, a multiplexing block can be formed simply.

Hereinafter, a whole procedure of transmitting uplink signals in accordance with the aforementioned embodiments of the present invention will be described. For convenience of description, this procedure will be described with reference to FIG. 2.

In order to transmit the uplink signals in accordance with each of the embodiments of the present invention, the transmitter performs channel coding for each of data signals, control signals, and ACK/NACK signals. Channel coding for each of the uplink signals can be performed independently as illustrated in FIG. 2.

At this time, as illustrated in FIG. 2, the procedure of performing channel coding for the data signals can include steps of segmenting a TB attached with CRC for TB in a unit of CB (S202), attaching a CRC for CB to the segmented CBs (S203), performing channel coding for the data attached with the CRC for CB (S204), performing rate matching for the channel coded

data (S206), and performing CB concatenation (S207).

The one embodiment of the present invention suggests that the channel coded data and control signals are multiplexed serially. Serial multiplexing means that the control signals are mapped with sequential indexes directly after the data signals are mapped with them, or vice versa. Meanwhile, the multiplexed signals can sequentially be mapped within a specific resource region in accordance with the time-first mapping method, wherein the specific resource region includes a plurality of symbols (for example, 12 SC-FDMA symbols) and a plurality of virtual subcarriers.

In addition, in this embodiment of the present invention, the ACK/NACK signals are preferably arranged near the symbols to which the reference signal is transmitted, among the plurality of symbols.

It will be apparent to those skilled in the art that the present invention can be embodied in other specific forms without departing from the spirit and essential characteristics of the invention. Thus, the above embodiments are to be considered in all respects as illustrative and not restrictive. The scope of the invention should be determined by reasonable interpretation of the appended claims and all change which comes within the equivalent scope of the invention are included in the scope of the invention.

The embodiments of the present invention can be applied

to various systems, which require data signal transmission, control signal transmission, and ACK/NACK signal transmission through the uplink, in addition to the 3GPP LTE system.

**WHAT IS CLAIMED IS:**

1. A method for transmitting uplink signals, which include ACK/NACK signals, control signals other than the ACK/NACK signals, and data signals, the method comprising:

serially multiplexing the control signals and the data signals;

sequentially mapping the multiplexed signals within a specific resource region in accordance with a time-first mapping method, the specific resource region including a plurality of symbols and a plurality of virtual subcarriers; and

arranging the ACK/NACK signals at both symbols near to the symbols through which a reference signal is transmitted.

2. The method of claim 1, wherein the ACK/NACK signals are overwritten on a part of the multiplexed signals.

3. The method of claim 2, wherein the part of the multiplexed signals, on which the ACK/NACK signals are overwritten, includes one or more of the control signals and the data signals.

4. The method of claim 1, further comprising:

performing a discrete fourier transform (DFT) for the signals mapped on the specific resource region in a unit of

each symbol of the plurality of symbols in accordance with each index of the plurality of virtual subcarriers;

performing an inverse fast fourier transform (IFFT) for the DFT symbol unit signals and attaching a cyclic prefix (CP) thereto; and

transmitting the symbol unit signals attached with the CP as single carrier frequency division multiplexing access (SC-FDMA) symbols.

5. The method of any one of claims 1 to 4, further comprising transmitting the signals mapped on the specific resource region through a physical uplink sharing channel (PUSCH).

6. The method of claim 2 or 3, wherein the part of the multiplexed signals, on which the ACK/NACK signals are overwritten, are equally distributed within the plurality of virtual subcarriers.

7. A method for transmitting uplink signals, which include ACK/NACK signals, control signals other than the ACK/NACK signals, and data signals, the method comprising:

performing channel coding for each of the data signals, the control signals, and the ACK/NACK signals;

serially multiplexing the channel coded data and the

control signals;

sequentially mapping the multiplexed signals within a specific resource region in accordance with a time-first mapping method, the specific resource region including a plurality of symbols and a plurality of virtual subcarriers; and

arranging the ACK/NACK signals at both symbols near to the symbols through which a reference signal is transmitted.

8. The method of claim 7, wherein said performing channel coding for the data signals includes:

attaching a CRC for a transport block (TB) to a transport block for transmission of the data signals;

segmenting the transport block attached with the CRC for the transport block in a code block unit and attaching a CRC for a code block to the segmented code block;

performing channel coding for the data attached with the CRC for the code block; and

performing rate matching and code block concatenation for the channel coded data.



**ABSTRACT OF THE DISCLOSURE**

A method for transmitting uplink signals, which include ACK/NACK signals, control signals other than the ACK/NACK signals, and data signals, is disclosed. The method comprises serially multiplexing the control signals and the data signals; sequentially mapping the multiplexed signals within a specific resource region in accordance with a time-first mapping method, the specific resource region including a plurality of symbols and a plurality of virtual subcarriers; and arranging the ACK/NACK signals at both symbols near symbols to which a reference signal of the plurality of symbols is transmitted. Thus, the uplink signals can be transmitted to improve receiving reliability of signals having high priority.

## Electronic Patent Application Fee Transmittal

<b>Application Number:</b>				
<b>Filing Date:</b>				
<b>Title of Invention:</b>	METHOD FOR TRANSMITTING UPLINK SIGNALS			
<b>First Named Inventor/Applicant Name:</b>	Dae Won Lee			
<b>Filer:</b>	Harry Sung Lee/Maggie Wen			
<b>Attorney Docket Number:</b>	2101-3573			
Filed as Large Entity				
<b>Utility under 35 USC 111(a) Filing Fees</b>				
<b>Description</b>	<b>Fee Code</b>	<b>Quantity</b>	<b>Amount</b>	<b>Sub-Total in USD(\$)</b>
<b>Basic Filing:</b>				
Utility application filing	1011	1	310	310
Utility Search Fee	1111	1	510	510
Utility Examination Fee	1311	1	210	210
<b>Pages:</b>				
<b>Claims:</b>				
Multiple dependent claims	1203	1	370	370
<b>Miscellaneous-Filing:</b>				
<b>Petition:</b>				

Description	Fee Code	Quantity	Amount	Sub-Total in USD(\$)
<b>Patent-Appeals-and-Interference:</b>				
<b>Post-Allowance-and-Post-Issuance:</b>				
<b>Extension-of-Time:</b>				
<b>Miscellaneous:</b>				
<b>Total in USD (\$)</b>				<b>1400</b>

## Electronic Acknowledgement Receipt

<b>EFS ID:</b>	3930420
<b>Application Number:</b>	12209136
<b>International Application Number:</b>	
<b>Confirmation Number:</b>	3897
<b>Title of Invention:</b>	METHOD FOR TRANSMITTING UPLINK SIGNALS
<b>First Named Inventor/Applicant Name:</b>	Dae Won Lee
<b>Customer Number:</b>	35884
<b>Filer:</b>	Harry Sung Lee/Maggie Wen
<b>Filer Authorized By:</b>	Harry Sung Lee
<b>Attorney Docket Number:</b>	2101-3573
<b>Receipt Date:</b>	11-SEP-2008
<b>Filing Date:</b>	
<b>Time Stamp:</b>	19:56:04
<b>Application Type:</b>	Utility under 35 USC 111(a)

### Payment information:

Submitted with Payment	yes
Payment Type	Deposit Account
Payment was successfully received in RAM	\$1400
RAM confirmation Number	6157
Deposit Account	502290
Authorized User	

The Director of the USPTO is hereby authorized to charge indicated fees and credit any overpayment as follows:

Charge any Additional Fees required under 37 C.F.R. Section 1.16 (National application filing, search, and examination fees)

Charge any Additional Fees required under 37 C.F.R. Section 1.17 (Patent application and reexamination processing fees)

<b>File Listing:</b>					
<b>Document Number</b>	<b>Document Description</b>	<b>File Name</b>	<b>File Size(Bytes)/ Message Digest</b>	<b>Multi Part /.zip</b>	<b>Pages (if appl.)</b>
1	Transmittal of New Application	2101-3573_XM.pdf	101522 96c3472395d880cd20069dcccde88ca72b1d f29a8	no	2
<b>Warnings:</b>					
<b>Information:</b>					
2		2101-3573_Application.pdf	1241239 31cbc69c17844d315c60e82c4a2530ffe80a 3971	yes	27
	<b>Multipart Description/PDF files in .zip description</b>				
	<b>Document Description</b>		<b>Start</b>	<b>End</b>	
	Specification		1	23	
	Claims		24	26	
	Abstract		27	27	
<b>Warnings:</b>					
<b>Information:</b>					
3	Drawings-only black and white line drawings	2101-3573_Drawings.pdf	441386 b6c947e9367dfa9c010fd2dd995dd0bb954 50235	no	9
<b>Warnings:</b>					
<b>Information:</b>					
4	Fee Worksheet (PTO-06)	fee-info.pdf	36059 ce38c9e3ff3ea463f188bd1f8a7bdcbe9ad 1349	no	2
<b>Warnings:</b>					
<b>Information:</b>					
<b>Total Files Size (in bytes):</b>			1820206		

**This Acknowledgement Receipt evidences receipt on the noted date by the USPTO of the indicated documents, characterized by the applicant, and including page counts, where applicable. It serves as evidence of receipt similar to a Post Card, as described in MPEP 503.**

**New Applications Under 35 U.S.C. 111**

**If a new application is being filed and the application includes the necessary components for a filing date (see 37 CFR 1.53(b)-(d) and MPEP 506), a Filing Receipt (37 CFR 1.54) will be issued in due course and the date shown on this Acknowledgement Receipt will establish the filing date of the application.**

**National Stage of an International Application under 35 U.S.C. 371**

**If a timely submission to enter the national stage of an international application is compliant with the conditions of 35 U.S.C. 371 and other applicable requirements a Form PCT/DO/EO/903 indicating acceptance of the application as a national stage submission under 35 U.S.C. 371 will be issued in addition to the Filing Receipt, in due course.**

**New International Application Filed with the USPTO as a Receiving Office**

**If a new international application is being filed and the international application includes the necessary components for an international filing date (see PCT Article 11 and MPEP 1810), a Notification of the International Application Number and of the International Filing Date (Form PCT/RO/105) will be issued in due course, subject to prescriptions concerning national security, and the date shown on this Acknowledgement Receipt will establish the international filing date of the application.**

FIG. 1

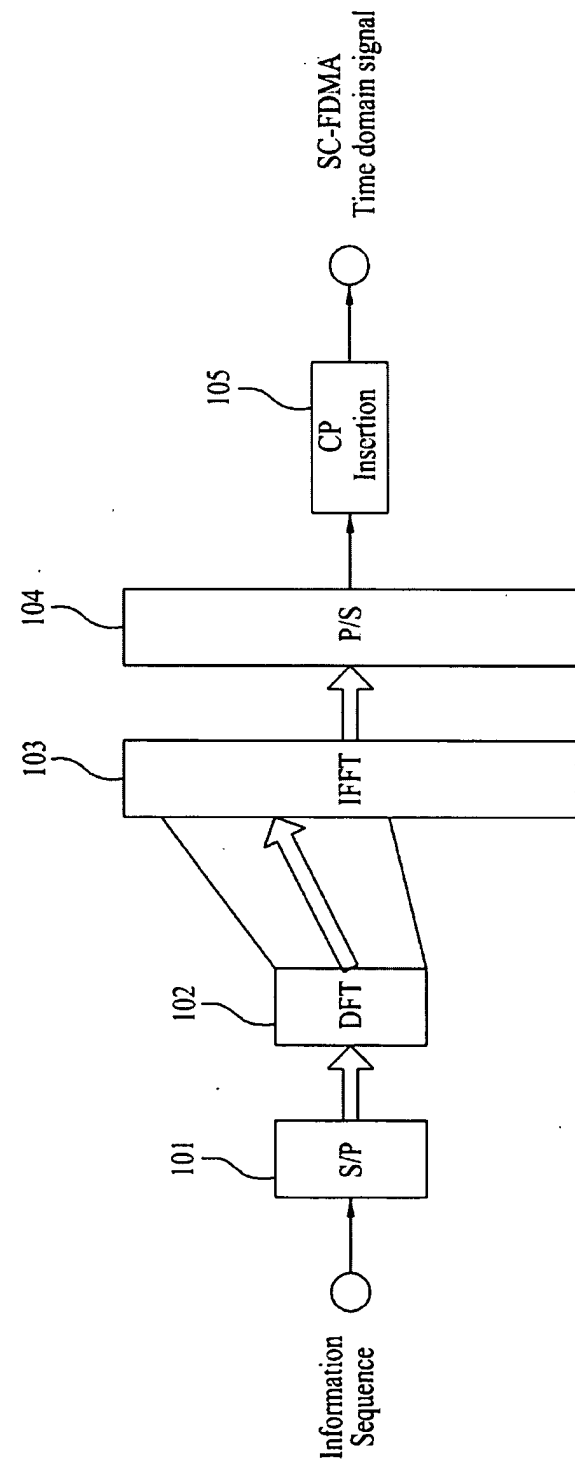

FIG. 2

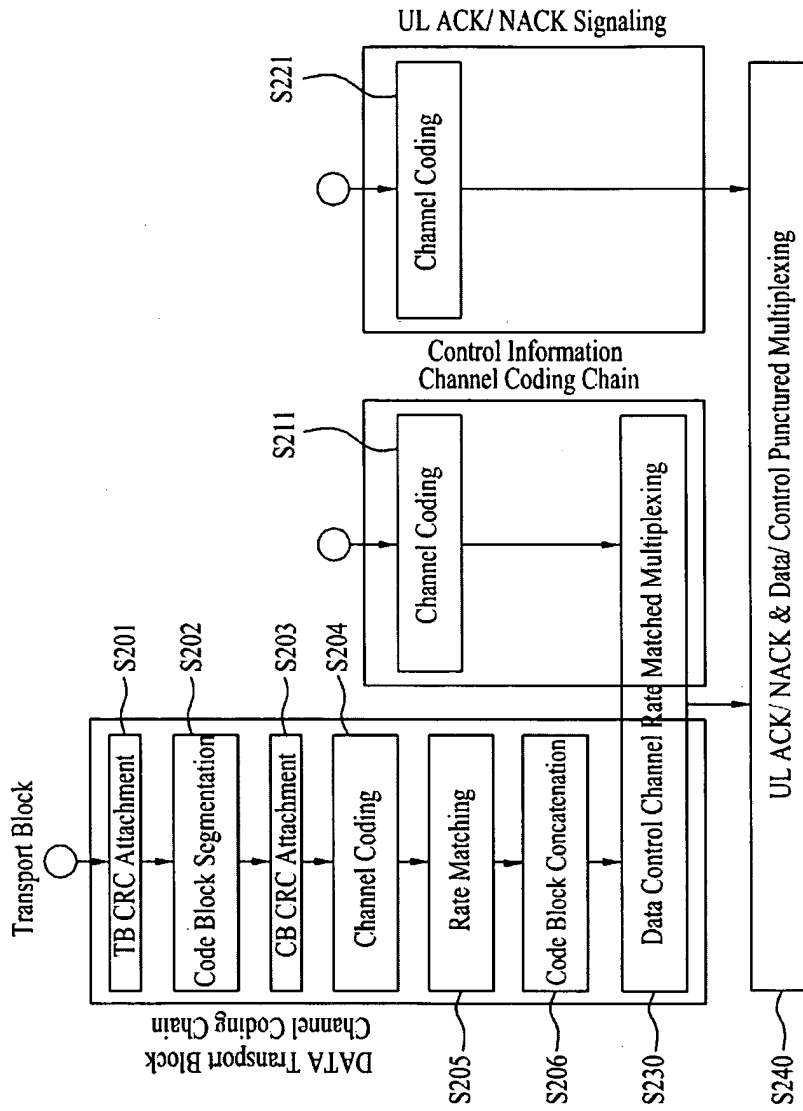



FIG. 3

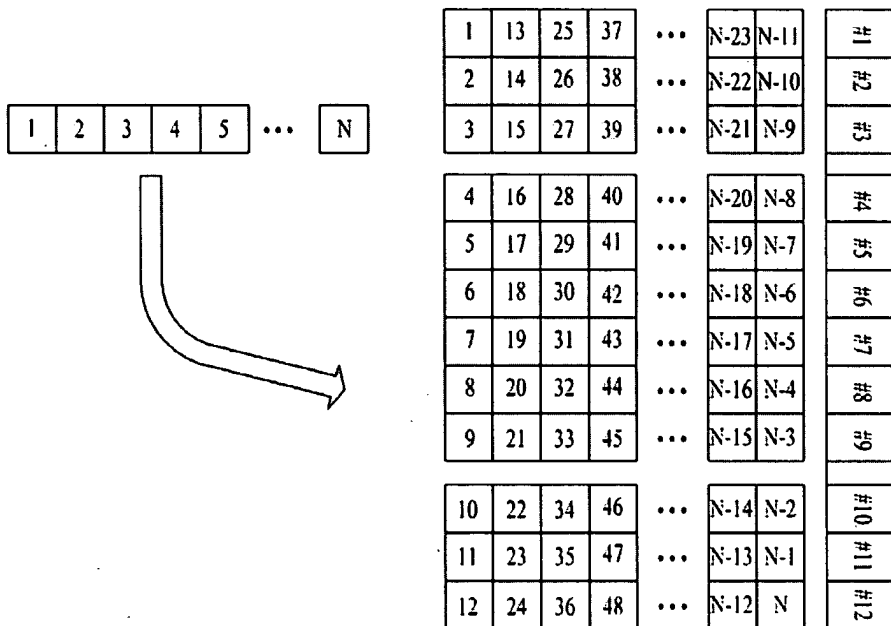

FIG. 4

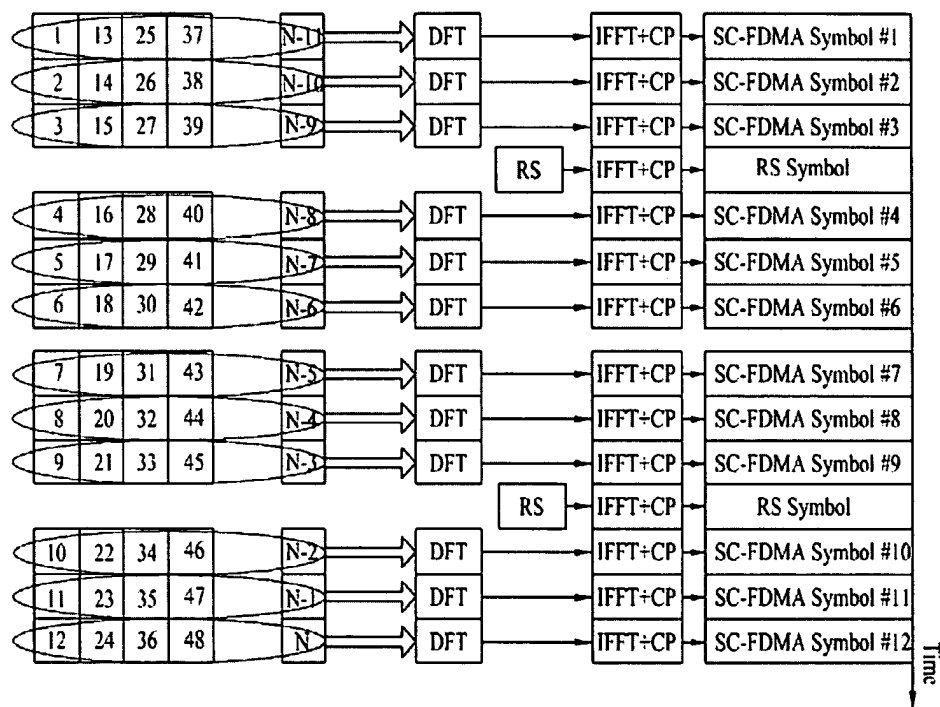

FIG. 5

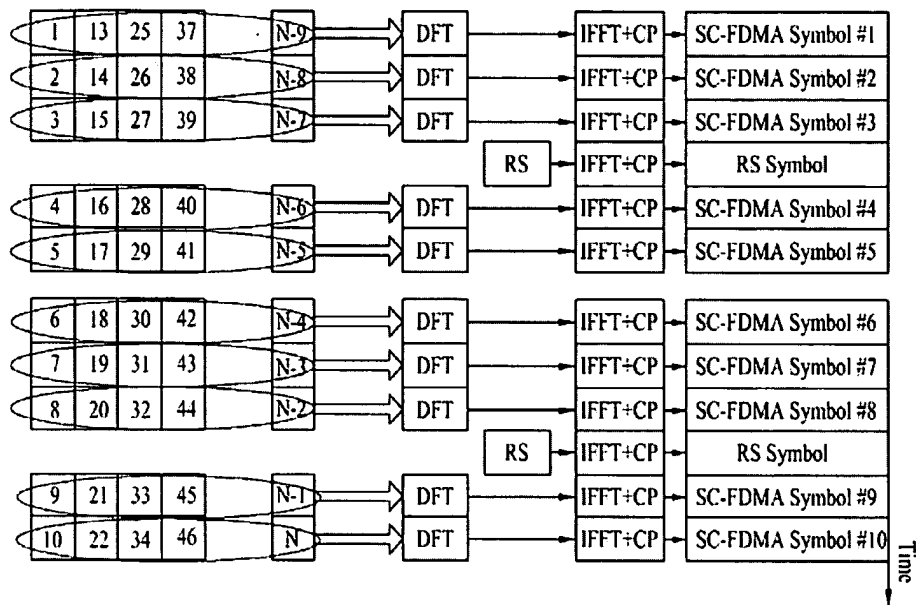

FIG. 6

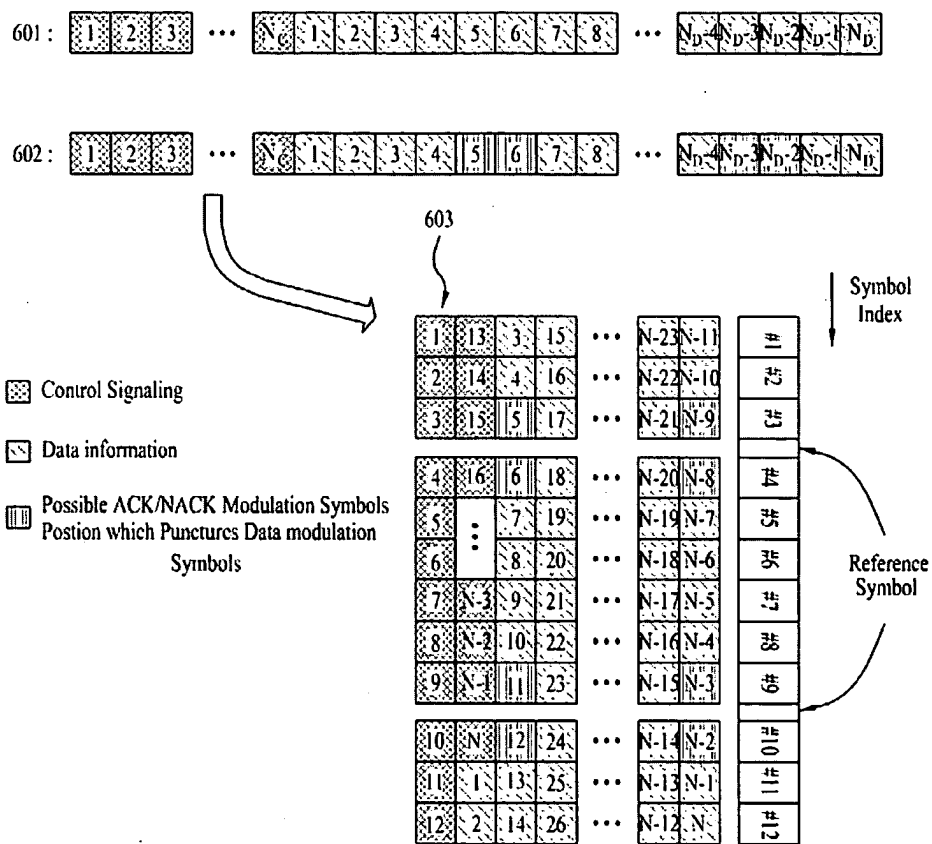

FIG. 7

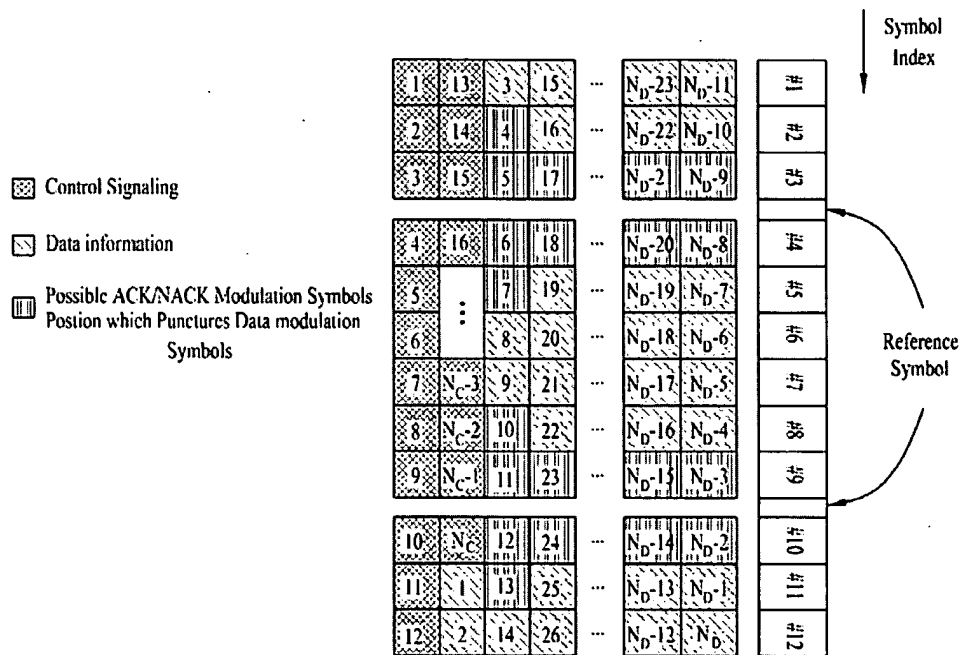

FIG. 8

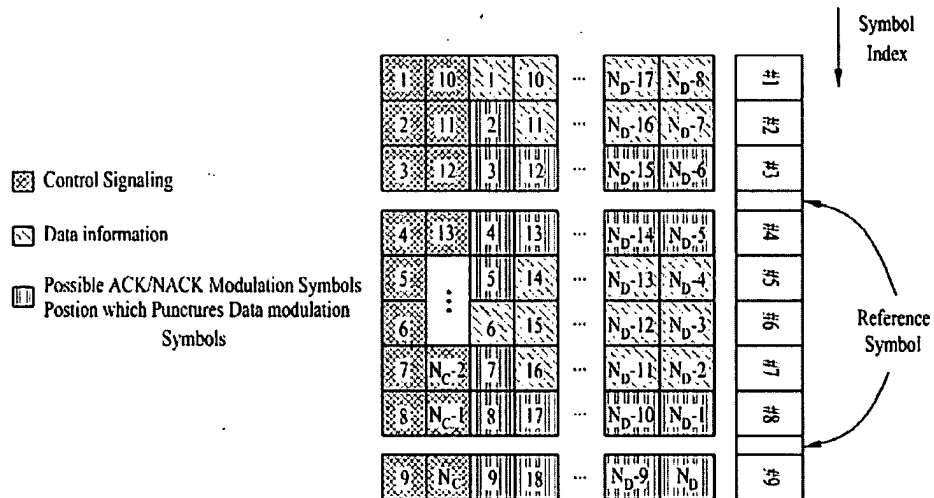
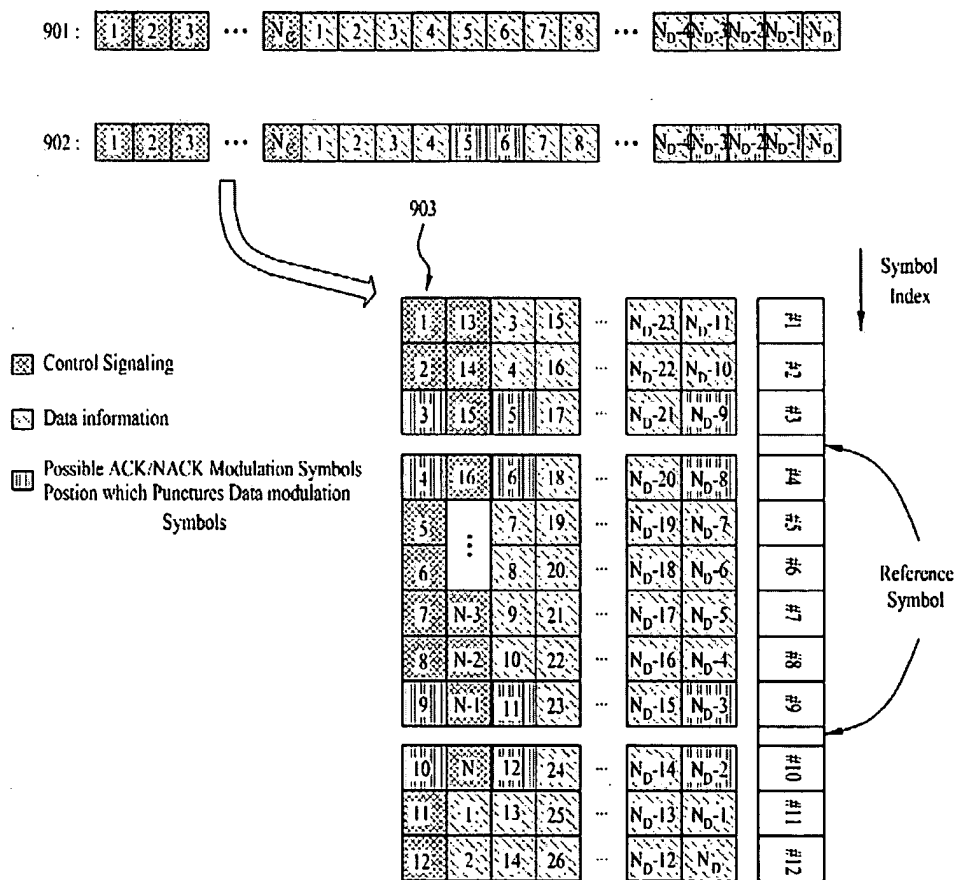

FIG. 9



Filing Date: 09/11/08

Approved for use through 7/31/2006. OMB 0651-0032

U.S. Patent and Trademark Office; U.S. DEPARTMENT OF COMMERCE

Under the Paperwork Reduction Act of 1995, no persons are required to respond to a collection of information unless it displays a valid OMB control number.

**PATENT APPLICATION FEE DETERMINATION RECORD**  
Substitute for Form PTO-875 12/209,136

APPLICATION AS FILED – PART I			SMALL ENTITY		OTHER THAN SMALL ENTITY	
	(Column 1)	(Column 2)				
FOR	NUMBER FILED	NUMBER EXTRA	RATE (\$)	FEE (\$)	RATE (\$)	FEE (\$)
BASIC FEE (37 CFR 1.16(a), (b), or (c))	N/A	N/A	N/A		N/A	310
SEARCH FEE (37 CFR 1.16(k), (i), or (m))	N/A	N/A	N/A		N/A	510
EXAMINATION FEE (37 CFR 1.16(o), (p), or (q))	N/A	N/A	N/A		N/A	210
TOTAL CLAIMS (37 CFR 1.16(i))	12	minus 20 = * 0	X\$ 25		X\$50	0
INDEPENDENT CLAIMS (37 CFR 1.16(h))	2	minus 3 = * 0	X\$105		X\$210	0
APPLICATION SIZE FEE (37 CFR 1.16(s))	If the specification and drawings exceed 100 sheets of paper, the application size fee due is \$250 (\$125 for small entity) for each additional 50 sheets or fraction thereof. See 35 U.S.C. 41(a)(1)(G) and 37 CFR		130		260	
MULTIPLE DEPENDENT CLAIM PRESENT (37 CFR 1.16(j))			185		370	370
			TOTAL	0	TOTAL	1400

\* If the difference in column 1 is less than zero, enter "0" in column 2.

APPLICATION AS AMENDED – PART II					SMALL ENTITY		OTHER THAN SMALL ENTITY	
	(Column 1)	(Column 2)	(Column 3)					
AMENDMENT A	CLAIMS REMAINING AFTER AMENDMENT	HIGHEST NUMBER PREVIOUSLY PAID FOR	PRESENT EXTRA	RATE (\$)	ADDITIONAL FEE (\$)	RATE (\$)	ADDITIONAL FEE (\$)	ADDITIONAL FEE (\$)
Total (37 CFR 1.16(i))	*	Minus **	=	X =		X =		
Independent (37 CFR 1.16(h))	*	Minus ***	=	X =		X =		
Application Size Fee (37 CFR 1.16(s))								
FIRST PRESENTATION OF MULTIPLE DEPENDENT CLAIM (37 CFR 1.16(j))					N/A		N/A	
					TOTAL ADD'T FEE		TOTAL ADD'T FEE	

APPLICATION AS AMENDED – PART II					SMALL ENTITY		OTHER THAN SMALL ENTITY	
	(Column 1)	(Column 2)	(Column 3)					
AMENDMENT B	CLAIMS REMAINING AFTER AMENDMENT	HIGHEST NUMBER PREVIOUSLY PAID FOR	PRESENT EXTRA	RATE (\$)	ADDITIONAL FEE (\$)	RATE (\$)	ADDITIONAL FEE (\$)	ADDITIONAL FEE (\$)
Total (37 CFR 1.16(i))	*	Minus **	=	X =		X =		
Independent (37 CFR 1.16(h))	*	Minus ***	=	X =		X =		
Application Size Fee (37 CFR 1.16(s))								
FIRST PRESENTATION OF MULTIPLE DEPENDENT CLAIM (37 CFR 1.16(j))					N/A		N/A	
					TOTAL ADD'T FEE		TOTAL ADD'T FEE	

- \* If the entry in column 1 is less than the entry in column 2, write "0" in column 3.
- \*\* If the "Highest Number Previously Paid For" IN THIS SPACE is less than 20, enter "20".
- \*\*\* If the "Highest Number Previously Paid For" IN THIS SPACE is less than 3, enter "3".
- † The "Highest Number Previously Paid For" (Total or Independent) is the highest number found in the appropriate box in column 1.

This collection of information is required by 37 CFR 1.16. The information is required to obtain or retain a benefit by the public which is to file (and by the USPTO to process) an application. Confidentiality is governed by 35 U.S.C. 122 and 37 CFR 1.14. This collection is estimated to take 12 minutes to complete, including gathering, preparing, and submitting the completed application form to the USPTO. Time will vary depending upon the individual case. Any comments on the amount of time you require to complete this form and/or suggestions for reducing this burden, should be sent to the Chief Information Officer, U.S. Patent and Trademark Office, U.S. Department of Commerce, P.O. Box 1450, Alexandria, VA 22313-1450. DO NOT SEND FEES OR COMPLETED FORMS TO THIS ADDRESS. SEND TO: Commissioner for Patents, P.O. Box 1450, Alexandria, VA 22313-1450.

If you need assistance in completing the form, call 1-800-PTO-9199 and select option 2.