

TO: <b>Mail Stop 8</b> <b>Director of the U.S. Patent and Trademark Office</b> P.O. Box 1450 Alexandria, VA 22313-1450	<b>REPORT ON THE                  FILING OR DETERMINATION OF AN                  ACTION REGARDING A PATENT OR                  TRADEMARK</b>
---	--

In Compliance with 35 U.S.C. § 290 and/or 15 U.S.C. § 1116 you are hereby advised that a court action has been filed in the U.S. District Court Western District of Texas - Austin Division on the following

Trademarks or  Patents. (  the patent action involves 35 U.S.C. § 292.):

DOCKET NO. 1:19-CV-874-ADA	DATE FILED 09/09/2019	U.S. DISTRICT COURT Western District of Texas - Austin Division
PLAINTIFF NEODRON LTD.,		DEFENDANT MICROSOFT CORPORATION,
PATENT OR TRADEMARK NO.	DATE OF PATENT OR TRADEMARK	HOLDER OF PATENT OR TRADEMARK
1 8,102,286	1/24/2012	Neodron Ltd.
2 9,086,770	7/21/2015	Neodron Ltd.
3 8,946,574	2/3/2015	Neodron Ltd.
4 8,502,547	8/6/2013	Neodron Ltd.
5 10,088,960	10/2/2018	Neodron Ltd.

In the above—entitled case, the following patent(s)/ trademark(s) have been included:

DATE INCLUDED	INCLUDED BY	
	<input type="checkbox"/> Amendment <input type="checkbox"/> Answer <input type="checkbox"/> Cross Bill <input type="checkbox"/> Other Pleading	
PATENT OR TRADEMARK NO.	DATE OF PATENT OR TRADEMARK	HOLDER OF PATENT OR TRADEMARK
1		
2		
3		
4		
5		

In the above—entitled case, the following decision has been rendered or judgement issued:

DECISION/JUDGEMENT
--------------------

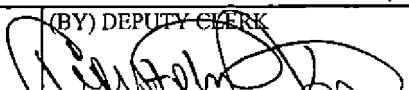
CLERK <b>Jeannette J. Clack</b>	(BY) DEPUTY CLERK 	DATE Sept 9, 2019
------------------------------------	---	----------------------

Copy 1—Upon initiation of action, mail this copy to Director    Copy 3—Upon termination of action, mail this copy to Director  
 Copy 2—Upon filing document adding patent(s), mail this copy to Director    Copy 4—Case file copy

<b>TO:</b> <b>Mail Stop 8</b> <b>Director of the U.S. Patent and Trademark Office</b> <b>P.O. Box 1450</b> <b>Alexandria, VA 22313-1450</b>	<b>REPORT ON THE</b> <b>FILING OR DETERMINATION OF AN</b> <b>ACTION REGARDING A PATENT OR</b> <b>TRADEMARK</b>
--	---

In Compliance with 35 U.S.C. § 290 and/or 15 U.S.C. § 1116 you are hereby advised that a court action has been filed in the U.S. District Court Western District of Texas on the following

Trademarks or  Patents. (  the patent action involves 35 U.S.C. § 292.):

DOCKET NO. 6:19-cv-399	DATE FILED 6/28/2019	U.S. DISTRICT COURT Western District of Texas
PLAINTIFF NEODRON LTD.,		DEFENDANT MICROSOFT CORPORATION,
PATENT OR TRADEMARK NO.	DATE OF PATENT OR TRADEMARK	HOLDER OF PATENT OR TRADEMARK
1 8,102,286	1/24/2012	Neodron Ltd.
2 9,086,770	7/21/2015	Neodron Ltd.
3 8,946,574	2/3/2015	Neodron Ltd.
4 8,502,547	8/6/2013	Neodron Ltd.
5 10,088,960	10/2/2018	Neodron Ltd.

In the above—entitled case, the following patent(s)/ trademark(s) have been included:

DATE INCLUDED	INCLUDED BY	
	<input type="checkbox"/> Amendment <input type="checkbox"/> Answer <input type="checkbox"/> Cross Bill <input type="checkbox"/> Other Pleading	
PATENT OR TRADEMARK NO.	DATE OF PATENT OR TRADEMARK	HOLDER OF PATENT OR TRADEMARK
1		
2		
3		
4		
5		

In the above—entitled case, the following decision has been rendered or judgement issued:

DECISION/JUDGEMENT

CLERK <i>Jeannette J. Clack</i>	(BY) DEPUTY CLERK <i>UDiaz</i>	DATE <i>7/1/19</i>
------------------------------------	-----------------------------------	-----------------------

Copy 1—Upon initiation of action, mail this copy to Director    Copy 3—Upon termination of action, mail this copy to Director  
 Copy 2—Upon filing document adding patent(s), mail this copy to Director    Copy 4—Case file copy

AO 120 (Rev. 08/10)

TO: <b>Mail Stop 8 Director of the U.S. Patent and Trademark Office P.O. Box 1450 Alexandria, VA 22313-1450</b>	<b>REPORT ON THE FILING OR DETERMINATION OF AN ACTION REGARDING A PATENT OR TRADEMARK</b>
---	---

In Compliance with 35 U.S.C. § 290 and/or 15 U.S.C. § 1116 you are hereby advised that a court action has been filed in the U.S. District Court Western District of Texas on the following

Trademarks or  Patents. (  the patent action involves 35 U.S.C. § 292.):

DOCKET NO. 6:19-cv-00398-ADA	DATE FILED 8/29/2019	U.S. DISTRICT COURT Western District of Texas
PLAINTIFF NEODRON LTD.,		DEFENDANT LENOVO GROUP LTD.; LENOVO (UNITED STATES) INC.; and MOTOROLA MOBILITY LLC,
PATENT OR TRADEMARK NO.	DATE OF PATENT OR TRADEMARK	HOLDER OF PATENT OR TRADEMARK
1 8,102,286	1/24/2012	Neodron Ltd.
2 8,451,237	5/28/2013	Neodron Ltd.
3 8,502,547	8/6/2013	Neodron Ltd.
4		
5		

In the above—entitled case, the following patent(s)/ trademark(s) have been included:

DATE INCLUDED	INCLUDED BY	
	<input checked="" type="checkbox"/> Amendment <input type="checkbox"/> Answer <input type="checkbox"/> Cross Bill <input type="checkbox"/> Other Pleading	
PATENT OR TRADEMARK NO.	DATE OF PATENT OR TRADEMARK	HOLDER OF PATENT OR TRADEMARK
1 8,946,574	2/3/2015	Neodron Ltd.
2 9,086,770	7/21/2015	Neodron Ltd.
3 10,088,960	10/2/2018	Neodron Ltd.
4 7,821,502	10/26/2010	Neodron Ltd.
5		

In the above—entitled case, the following decision has been rendered or judgement issued:

DECISION/JUDGEMENT

CLERK <i>Jeannette J. Clack</i>	(BY) DEPUTY CLERK <i>L Diaz</i>	DATE <i>8/30/19</i>
------------------------------------	------------------------------------	------------------------

Copy 1—Upon initiation of action, mail this copy to Director    Copy 3—Upon termination of action, mail this copy to Director  
Copy 2—Upon filing document adding patent(s), mail this copy to Director    Copy 4—Case file copy

<b>TO:</b> Mail Stop 8 <b>Director of the U.S. Patent and Trademark Office</b> <b>P.O. Box 1450</b> <b>Alexandria, VA 22313-1450</b>	<b>REPORT ON THE</b> <b>FILING OR DETERMINATION OF AN</b> <b>ACTION REGARDING A PATENT OR</b> <b>TRADEMARK</b>
---	---

In Compliance with 35 U.S.C. § 290 and/or 15 U.S.C. § 1116 you are hereby advised that a court action has been filed in the U.S. District Court Western District of Texas on the following

Trademarks or  Patents. (  the patent action involves 35 U.S.C. § 292.):

DOCKET NO. 1:19-cv-00819-ADA	DATE FILED 8/28/2019	U.S. DISTRICT COURT Western District of Texas
PLAINTIFF NEODRON LTD.,		DEFENDANT DELL TECHNOLOGIES, INC.
PATENT OR TRADEMARK NO.	DATE OF PATENT OR TRADEMARK	HOLDER OF PATENT OR TRADEMARK
1 8,102,286	1/24/2012	Neodron Ltd.
2 8,451,237	5/28/2013	Neodron Ltd.
3 8,502,547	8/6/2013	Neodron Ltd.
4		
5		

In the above—entitled case, the following patent(s)/ trademark(s) have been included:

DATE INCLUDED	INCLUDED BY <input checked="" type="checkbox"/> Amendment <input type="checkbox"/> Answer <input type="checkbox"/> Cross Bill <input type="checkbox"/> Other Pleading	
PATENT OR TRADEMARK NO.	DATE OF PATENT OR TRADEMARK	HOLDER OF PATENT OR TRADEMARK
1 8,946,574	2/3/2015	Neodron Ltd.
2 10,088,960	10/2/2018	Neodron Ltd.
3 7,821,502	10/26/2010	Neodron Ltd.
4		
5		

In the above—entitled case, the following decision has been rendered or judgement issued:

DECISION/JUDGEMENT
--------------------

CLERK JEANNETTE J. CLACK	(BY) DEPUTY CLERK 	DATE 8/29/19
-----------------------------	---	-----------------

Copy 1—Upon initiation of action, mail this copy to Director Copy 3—Upon termination of action, mail this copy to Director  
 Copy 2—Upon filing document adding patent(s), mail this copy to Director Copy 4—Case file copy



AO 120 (Rev. 08/10)

TO: <b>Mail Stop 8</b> <b>Director of the U.S. Patent and Trademark Office</b> P.O. Box 1450 Alexandria, VA 22313-1450	<b>REPORT ON THE                  FILING OR DETERMINATION OF AN                  ACTION REGARDING A PATENT OR                  TRADEMARK</b>
---	--

In Compliance with 35 U.S.C. § 290 and/or 15 U.S.C. § 1116 you are hereby advised that a court action has been filed in the U.S. District Court Western District of Texas on the following

Trademarks or  Patents. (  the patent action involves 35 U.S.C. § 292.):

DOCKET NO. 6:19-cv-00397-ADA	DATE FILED 8/27/2019	U.S. DISTRICT COURT Western District of Texas
PLAINTIFF NEODRON LTD.,		DEFENDANT HP INC.,
PATENT OR TRADEMARK NO.	DATE OF PATENT OR TRADEMARK	HOLDER OF PATENT OR TRADEMARK
1 8,102,286	1/24/2012	Neodron Ltd.
2 8,847,898	9/30/2014	Neodron Ltd.
3 8,451,237	5/28/2013	Neodron Ltd.
4 8,502,547	8/6/2013	Neodron Ltd.
5		

In the above—entitled case, the following patent(s)/ trademark(s) have been included:

DATE INCLUDED	INCLUDED BY	
	<input checked="" type="checkbox"/> Amendment <input type="checkbox"/> Answer <input type="checkbox"/> Cross Bill <input type="checkbox"/> Other Pleading	
PATENT OR TRADEMARK NO.	DATE OF PATENT OR TRADEMARK	HOLDER OF PATENT OR TRADEMARK
1 8,946,574	2/3/2015	Neodron Ltd.
2 9,086,770	7/21/2015	Neodron Ltd.
3 10,088,960	10/2/2018	Neodron Ltd.
4 7,821,502	10/26/2010	Neodron Ltd.
5		

In the above—entitled case, the following decision has been rendered or judgement issued:

DECISION/JUDGEMENT

CLERK <i>Jeannette J. Clack</i>	(BY) DEPUTY CLERK <i>L. Diaz</i>	DATE 8/28/19
------------------------------------	-------------------------------------	-----------------

Copy 1—Upon initiation of action, mail this copy to Director    Copy 3—Upon termination of action, mail this copy to Director  
 Copy 2—Upon filing document adding patent(s), mail this copy to Director    Copy 4—Case file copy



APPLICATION NO.	ISSUE DATE	PATENT NO.	ATTORNEY DOCKET NO.	CONFIRMATION NO.
13/312,405	02/03/2015	8946574	080900.1371	6025

12323 7590 01/14/2015  
Baker Botts L.L.P.  
2001 Ross Avenue, 6th Floor  
Dallas, TX 75201

### ISSUE NOTIFICATION

The projected patent number and issue date are specified above.

#### **Determination of Patent Term Adjustment under 35 U.S.C. 154 (b)** (application filed on or after May 29, 2000)

The Patent Term Adjustment is 0 day(s). Any patent to issue from the above-identified application will include an indication of the adjustment on the front page.

If a Continued Prosecution Application (CPA) was filed in the above-identified application, the filing date that determines Patent Term Adjustment is the filing date of the most recent CPA.

Applicant will be able to obtain more detailed information by accessing the Patent Application Information Retrieval (PAIR) WEB site (<http://pair.uspto.gov>).

Any questions regarding the Patent Term Extension or Adjustment determination should be directed to the Office of Patent Legal Administration at (571)-272-7702. Questions relating to issue and publication fee payments should be directed to the Application Assistance Unit (AAU) of the Office of Data Management (ODM) at (571)-272-4200.

APPLICANT(s) (Please see PAIR WEB site <http://pair.uspto.gov> for additional applicants):

David Brent Guard, Hampshire, UNITED KINGDOM;  
Esat Yilmaz, Santa Cruz, CA;  
Tsung-Ching Wu, Saratoga, CA;

The United States represents the largest, most dynamic marketplace in the world and is an unparalleled location for business investment, innovation, and commercialization of new technologies. The USA offers tremendous resources and advantages for those who invest and manufacture goods here. Through SelectUSA, our nation works to encourage and facilitate business investment. To learn more about why the USA is the best country in the world to develop technology, manufacture products, and grow your business, visit [SelectUSA.gov](http://SelectUSA.gov).

**PART B - FEE(S) TRANSMITTAL**

Complete and send this form, together with applicable fee(s), to: **Mail** Mail Stop ISSUE FEE  
**Commissioner for Patents**  
**P.O. Box 1450**  
**Alexandria, Virginia 22313-1450**  
**or Fax (571)-273-2885**

**INSTRUCTIONS:** This form should be used for transmitting the ISSUE FEE and PUBLICATION FEE (if required). Blocks 1 through 5 should be completed where appropriate. All further correspondence including the Patent, advance orders and notification of maintenance fees will be mailed to the current correspondence address as indicated unless corrected below or directed otherwise in Block 1, by (a) specifying a new correspondence address; and/or (b) indicating a separate "FEE ADDRESS" for maintenance fee notifications.

CURRENT CORRESPONDENCE ADDRESS (Note: Use Block 1 for any change of address)

12323 7590 11/21/2014  
**Baker Botts L.L.P.**  
 2001 Ross Avenue, 6th Floor  
 Dallas, TX 75201

Note: A certificate of mailing can only be used for domestic mailings of the Fee(s) Transmittal. This certificate cannot be used for any other accompanying papers. Each additional paper, such as an assignment or formal drawing, must have its own certificate of mailing or transmission.

**Certificate of Mailing or Transmission**

I hereby certify that this Fee(s) Transmittal is being deposited with the United States Postal Service with sufficient postage for first class mail in an envelope addressed to the Mail Stop ISSUE FEE address above, or being facsimile transmitted to the USPTO (571) 273-2885, on the date indicated below.

(Depositor's name)
(Signature)
(Date)

APPLICATION NO.	FILING DATE	FIRST NAMED INVENTOR	ATTORNEY DOCKET NO.	CONFIRMATION NO.
13/312,405	12/06/2011	David Brent Guard	080900.1371	6025

TITLE OF INVENTION: TWO-LAYER SENSOR STACK

APPLN. TYPE	ENTITY STATUS	ISSUE FEE DUE	PUBLICATION FEE DUE	PREV. PAID ISSUE FEE	TOTAL FEE(S) DUE	DATE DUE
nonprovisional	UNDISCOUNTED	\$960	\$0	\$0	\$960	02/23/2015

EXAMINER	ART UNIT	CLASS-SUBCLASS
SAEED, AHMED M	2833	200-181000

<p>1. Change of correspondence address or indication of "Fee Address" (37 CFR 1.363).</p> <p><input type="checkbox"/> Change of correspondence address (or Change of Correspondence Address form PTO/SB/122) attached.</p> <p><input type="checkbox"/> "Fee Address" indication (or "Fee Address" Indication form PTO/SB/47; Rev 03-02 or more recent) attached. <b>Use of a Customer Number is required.</b></p>	<p>2. For printing on the patent front page, list</p> <p>(1) The names of up to 3 registered patent attorneys or agents OR, alternatively,</p> <p>(2) The name of a single firm (having as a member a registered attorney or agent) and the names of up to 2 registered patent attorneys or agents. If no name is listed, no name will be printed.</p> <p>1 <u>Baker Botts LLP</u></p> <p>2 _____</p> <p>3 _____</p>
---	--

3. ASSIGNEE NAME AND RESIDENCE DATA TO BE PRINTED ON THE PATENT (print or type)

PLEASE NOTE: Unless an assignee is identified below, no assignee data will appear on the patent. If an assignee is identified below, the document has been filed for recordation as set forth in 37 CFR 3.11. Completion of this form is NOT a substitute for filing an assignment.

(A) NAME OF ASSIGNEE: Atmel Corporation

(B) RESIDENCE: (CITY and STATE OR COUNTRY) San Jose, CA

Please check the appropriate assignee category or categories (will not be printed on the patent):  Individual  Corporation or other private group entity  Government

<p>4a. The following fee(s) are submitted:</p> <p><input checked="" type="checkbox"/> Issue Fee</p> <p><input type="checkbox"/> Publication Fee (No small entity discount permitted)</p> <p><input type="checkbox"/> Advance Order - # of Copies _____</p>	<p>4b. Payment of Fee(s): (Please first reapply any previously paid issue fee shown above)</p> <p><input type="checkbox"/> A check is enclosed.</p> <p><input type="checkbox"/> Payment by credit card. Form PTO-2038 is attached.</p> <p><input checked="" type="checkbox"/> The director is hereby authorized to charge the required fee(s), any deficiency, or credits any overpayment, to Deposit Account Number <u>020384</u> (enclose an extra copy of this form).</p>
--	--

5. Change in Entity Status (from status indicated above)

Applicant certifying micro entity status. See 37 CFR 1.29

Applicant asserting small entity status. See 37 CFR 1.27

Applicant changing to regular undiscouted fee status.

**NOTE:** Absent a valid certification of Micro Entity Status (see forms PTO/SB/15A and 15B), issue fee payment in the micro entity amount will not be accepted at the risk of application abandonment.

**NOTE:** If the application was previously under micro entity status, checking this box will be taken to be a notification of loss of entitlement to micro entity status.

**NOTE:** Checking this box will be taken to be a notification of loss of entitlement to small or micro entity status, as applicable.

NOTE: This form must be signed in accordance with 37 CFR 1.31 and 1.33. See 37 CFR 1.4 for signature requirements and certifications.

Authorized Signature: Chad P. Terrell Date: 12/18/14

Typed or printed name: Chad P. Terrell Registration No. 52,279

IN THE UNITED STATES PATENT AND TRADEMARK OFFICE

In re Application of: David Brent Guard, et al.  
Serial No.: 13/312,405  
Filed: December 6, 2011  
Group No.: 2833  
Examiner: Ahmed M. Saeed  
Notice of Allowance Mailed: November 21, 2014  
Confirmation No.: 6025  
Title: Two-Layer Sensor Stack

**Mail Stop Issue Fee**  
Commissioner for Patents  
P.O. Box 1450  
Alexandria, VA 22313-1450

Dear Sir:

**COMMENTS ON STATEMENT OF REASONS FOR ALLOWANCE**

Applicants appreciate the Examiner's allowance of Claims 1, 4-10 and 13-19. Pursuant to 37 C.F.R. § 1.104, Applicants respectfully issue a statement commenting on the Examiner's reasons for allowance. Applicants respectfully disagree with the Examiner's reasons for allowance to the extent that they are inconsistent with applicable case law, statutes, and regulations. Furthermore, Applicants do not admit to any characterization or limitation of the claims or to any characterization of a reference by the Examiner, particularly any that are inconsistent with the language of the claims considered in their entirety and including all of their constituent limitations.

Respectfully submitted,  
BAKER BOTTS L.L.P.  
Attorneys for Applicants



Chad D. Terrell  
Registration No. 52,279

Date: 12/18/14  
CUSTOMER NO. 12323

## Electronic Patent Application Fee Transmittal

<b>Application Number:</b>	13312405
<b>Filing Date:</b>	06-Dec-2011
<b>Title of Invention:</b>	TWO-LAYER SENSOR STACK
<b>First Named Inventor/Applicant Name:</b>	David Brent Guard
<b>Filer:</b>	Vernon E. Evans/mary johnson
<b>Attorney Docket Number:</b>	080900.1371

Filed as Large Entity

**Filing Fees for Utility under 35 USC 111(a)**

Description	Fee Code	Quantity	Amount	Sub-Total in USD(\$)
<b>Basic Filing:</b>				
<b>Pages:</b>				
<b>Claims:</b>				
<b>Miscellaneous-Filing:</b>				
<b>Petition:</b>				
<b>Patent-Appeals-and-Interference:</b>				
<b>Post-Allowance-and-Post-Issuance:</b>				
Utility Appl Issue Fee	1501	1	960	960

Description	Fee Code	Quantity	Amount	Sub-Total in USD(\$)
<b>Extension-of-Time:</b>				
<b>Miscellaneous:</b>				
<b>Total in USD (\$)</b>				<b>960</b>

## Electronic Acknowledgement Receipt

<b>EFS ID:</b>	21007945
<b>Application Number:</b>	13312405
<b>International Application Number:</b>	
<b>Confirmation Number:</b>	6025
<b>Title of Invention:</b>	TWO-LAYER SENSOR STACK
<b>First Named Inventor/Applicant Name:</b>	David Brent Guard
<b>Customer Number:</b>	12323
<b>Filer:</b>	Vernon E. Evans/mary johnson
<b>Filer Authorized By:</b>	Vernon E. Evans
<b>Attorney Docket Number:</b>	080900.1371
<b>Receipt Date:</b>	18-DEC-2014
<b>Filing Date:</b>	06-DEC-2011
<b>Time Stamp:</b>	16:34:53
<b>Application Type:</b>	Utility under 35 USC 111(a)

### Payment information:

Submitted with Payment	yes
Payment Type	Deposit Account
Payment was successfully received in RAM	\$960
RAM confirmation Number	4042
Deposit Account	020384
Authorized User	

The Director of the USPTO is hereby authorized to charge indicated fees and credit any overpayment as follows:

Charge any Additional Fees required under 37 C.F.R. Section 1.16 (National application filing, search, and examination fees)

Charge any Additional Fees required under 37 C.F.R. Section 1.17 (Patent application and reexamination procedure fees)

PETITIONERS

Charge any Additional Fees required under 37 C.F.R. Section 1.19 (Document supply fees)  
 Charge any Additional Fees required under 37 C.F.R. Section 1.20 (Post Issuance fees)  
 Charge any Additional Fees required under 37 C.F.R. Section 1.21 (Miscellaneous fees and charges)

**File Listing:**

Document Number	Document Description	File Name	File Size(Bytes)/ Message Digest	Multi Part /.zip	Pages (if appl.)
1	Issue Fee Payment (PTO-85B)	0809001371issuefee.PDF	98915	no	1
			a020ff9d1991d8fd640cd7c532d993b7377291f6		
<b>Warnings:</b>					
<b>Information:</b>					
2	Post Allowance Communication - Incoming	0809001371comments.PDF	43999	no	1
			27212562fa249fd70d538e97d973881f6fd73ad1		
<b>Warnings:</b>					
<b>Information:</b>					
3	Fee Worksheet (SB06)	fee-info.pdf	30814	no	2
			1e8a56f6e2b0643a67d83bc29589281d64e5bd3d		
<b>Warnings:</b>					
<b>Information:</b>					
<b>Total Files Size (in bytes):</b>			173728		

**This Acknowledgement Receipt evidences receipt on the noted date by the USPTO of the indicated documents, characterized by the applicant, and including page counts, where applicable. It serves as evidence of receipt similar to a Post Card, as described in MPEP 503.**

**New Applications Under 35 U.S.C. 111**

**If a new application is being filed and the application includes the necessary components for a filing date (see 37 CFR 1.53(b)-(d) and MPEP 506), a Filing Receipt (37 CFR 1.54) will be issued in due course and the date shown on this Acknowledgement Receipt will establish the filing date of the application.**

**National Stage of an International Application under 35 U.S.C. 371**

**If a timely submission to enter the national stage of an international application is compliant with the conditions of 35 U.S.C. 371 and other applicable requirements a Form PCT/DO/EO/903 indicating acceptance of the application as a national stage submission under 35 U.S.C. 371 will be issued in addition to the Filing Receipt, in due course.**

**New International Application Filed with the USPTO as a Receiving Office**

**If a new international application is being filed and the international application includes the necessary components for an international filing date (see PCT Article 11 and MPEP 1810), a Notification of the International Application Number and of the International Filing Date (Form PCT/RO/105) will be issued in due course, subject to prescriptions concerning national security, and the date shown on this Acknowledgement Receipt will establish the international filing date of the application.**



UNITED STATES PATENT AND TRADEMARK OFFICE  
COMMISSIONER FOR PATENTS  
P.O.BOX 1450  
ALEXANDRIA VA 22313-1451

PRESORTED  
FIRST-CLASS MAIL  
U.S. POSTAGE PAID  
POSTEDIGITAL  
NNNNN

Baker Botts L.L.P.  
2001 Ross Avenue, 6th Floor  
Dallas, TX 75201



**Courtesy Reminder for  
Application Serial No: 13/312,405**

Attorney Docket No: 080900.1371

Customer Number: 12323

Date of Electronic Notification: 11/21/2014

This is a courtesy reminder that new correspondence is available for this application. If you have not done so already, please review the correspondence. The official date of notification of the outgoing correspondence will be indicated on the form PTOL-90 accompanying the correspondence.

An email notification regarding the correspondence was sent to the following email address(es) associated with your customer number:

ptomail1@bakerbotts.com  
ptomail2@bakerbotts.com

To view your correspondence online or update your email addresses, please visit us anytime at <https://sportal.uspto.gov/secure/myportal/privatepair>. If you have any questions, please email the Electronic Business Center (EBC) at [EBC@uspto.gov](mailto:EBC@uspto.gov) or call 1-866-217-9197.



NOTICE OF ALLOWANCE AND FEE(S) DUE

12323 7590 11/21/2014
Baker Botts L.L.P.
2001 Ross Avenue, 6th Floor
Dallas, TX 75201

EXAMINER

SAEED, AHMED M

ART UNIT PAPER NUMBER

2833

DATE MAILED: 11/21/2014

Table with 5 columns: APPLICATION NO., FILING DATE, FIRST NAMED INVENTOR, ATTORNEY DOCKET NO., CONFIRMATION NO.

13/312,405 12/06/2011 David Brent Guard 080900.1371 6025

TITLE OF INVENTION: TWO-LAYER SENSOR STACK

Table with 7 columns: APPLN. TYPE, ENTITY STATUS, ISSUE FEE DUE, PUBLICATION FEE DUE, PREV. PAID ISSUE FEE, TOTAL FEE(S) DUE, DATE DUE

nonprovisional UNDISCOUNTED \$960 \$0 \$0 \$960 02/23/2015

THE APPLICATION IDENTIFIED ABOVE HAS BEEN EXAMINED AND IS ALLOWED FOR ISSUANCE AS A PATENT. PROSECUTION ON THE MERITS IS CLOSED. THIS NOTICE OF ALLOWANCE IS NOT A GRANT OF PATENT RIGHTS. THIS APPLICATION IS SUBJECT TO WITHDRAWAL FROM ISSUE AT THE INITIATIVE OF THE OFFICE OR UPON PETITION BY THE APPLICANT. SEE 37 CFR 1.313 AND MPEP 1308.

THE ISSUE FEE AND PUBLICATION FEE (IF REQUIRED) MUST BE PAID WITHIN THREE MONTHS FROM THE MAILING DATE OF THIS NOTICE OR THIS APPLICATION SHALL BE REGARDED AS ABANDONED. THIS STATUTORY PERIOD CANNOT BE EXTENDED. SEE 35 U.S.C. 151. THE ISSUE FEE DUE INDICATED ABOVE DOES NOT REFLECT A CREDIT FOR ANY PREVIOUSLY PAID ISSUE FEE IN THIS APPLICATION. IF AN ISSUE FEE HAS PREVIOUSLY BEEN PAID IN THIS APPLICATION (AS SHOWN ABOVE), THE RETURN OF PART B OF THIS FORM WILL BE CONSIDERED A REQUEST TO REAPPLY THE PREVIOUSLY PAID ISSUE FEE TOWARD THE ISSUE FEE NOW DUE.

HOW TO REPLY TO THIS NOTICE:

I. Review the ENTITY STATUS shown above. If the ENTITY STATUS is shown as SMALL or MICRO, verify whether entitlement to that entity status still applies.

If the ENTITY STATUS is the same as shown above, pay the TOTAL FEE(S) DUE shown above.

If the ENTITY STATUS is changed from that shown above, on PART B - FEE(S) TRANSMITTAL, complete section number 5 titled "Change in Entity Status (from status indicated above)".

For purposes of this notice, small entity fees are 1/2 the amount of undiscounted fees, and micro entity fees are 1/2 the amount of small entity fees.

II. PART B - FEE(S) TRANSMITTAL, or its equivalent, must be completed and returned to the United States Patent and Trademark Office (USPTO) with your ISSUE FEE and PUBLICATION FEE (if required). If you are charging the fee(s) to your deposit account, section "4b" of Part B - Fee(s) Transmittal should be completed and an extra copy of the form should be submitted. If an equivalent of Part B is filed, a request to reapply a previously paid issue fee must be clearly made, and delays in processing may occur due to the difficulty in recognizing the paper as an equivalent of Part B.

III. All communications regarding this application must give the application number. Please direct all communications prior to issuance to Mail Stop ISSUE FEE unless advised to the contrary.

IMPORTANT REMINDER: Utility patents issuing on applications filed on or after Dec. 12, 1980 may require payment of maintenance fees. It is patentee's responsibility to ensure timely payment of maintenance fees when due.

**PART B - FEE(S) TRANSMITTAL**

**Complete and send this form, together with applicable fee(s), to: Mail Mail Stop ISSUE FEE  
 Commissioner for Patents  
 P.O. Box 1450  
 Alexandria, Virginia 22313-1450  
 or Fax (571)-273-2885**

**INSTRUCTIONS:** This form should be used for transmitting the ISSUE FEE and PUBLICATION FEE (if required). Blocks 1 through 5 should be completed where appropriate. All further correspondence including the Patent, advance orders and notification of maintenance fees will be mailed to the current correspondence address as indicated unless corrected below or directed otherwise in Block 1, by (a) specifying a new correspondence address; and/or (b) indicating a separate "FEE ADDRESS" for maintenance fee notifications.

Note: A certificate of mailing can only be used for domestic mailings of the Fee(s) Transmittal. This certificate cannot be used for any other accompanying papers. Each additional paper, such as an assignment or formal drawing, must have its own certificate of mailing or transmission.

CURRENT CORRESPONDENCE ADDRESS (Note: Use Block 1 for any change of address)

12323 7590 11/21/2014  
**Baker Botts L.L.P.**  
 2001 Ross Avenue, 6th Floor  
 Dallas, TX 75201

**Certificate of Mailing or Transmission**

I hereby certify that this Fee(s) Transmittal is being deposited with the United States Postal Service with sufficient postage for first class mail in an envelope addressed to the Mail Stop ISSUE FEE address above, or being facsimile transmitted to the USPTO (571) 273-2885, on the date indicated below.

(Depositor's name)
(Signature)
(Date)

APPLICATION NO.	FILING DATE	FIRST NAMED INVENTOR	ATTORNEY DOCKET NO.	CONFIRMATION NO.
13/312.405	12/06/2011	David Brent Guard	080900.1371	6025

TITLE OF INVENTION: TWO-LAYER SENSOR STACK

APPLN. TYPE	ENTITY STATUS	ISSUE FEE DUE	PUBLICATION FEE DUE	PREV. PAID ISSUE FEE	TOTAL FEE(S) DUE	DATE DUE
nonprovisional	UNDISCOUNTED	\$960	\$0	\$0	\$960	02/23/2015

EXAMINER	ART UNIT	CLASS-SUBCLASS
SAEED, AHMED M	2833	200-181000

<p>1. Change of correspondence address or indication of "Fee Address" (37 CFR 1.363).</p> <p><input type="checkbox"/> Change of correspondence address (or Change of Correspondence Address form PTO/SB/122) attached.</p> <p><input type="checkbox"/> "Fee Address" indication (or "Fee Address" Indication form PTO/SB/47; Rev 03-02 or more recent) attached. <b>Use of a Customer Number is required.</b></p>	<p>2. For printing on the patent front page, list</p> <p>(1) The names of up to 3 registered patent attorneys or agents OR, alternatively, _____ 1</p> <p>(2) The name of a single firm (having as a member a registered attorney or agent) and the names of up to 2 registered patent attorneys or agents. If no name is listed, no name will be printed. _____ 2</p> <p>_____ 3</p>
---	---

3. ASSIGNEE NAME AND RESIDENCE DATA TO BE PRINTED ON THE PATENT (print or type)

PLEASE NOTE: Unless an assignee is identified below, no assignee data will appear on the patent. If an assignee is identified below, the document has been filed for recordation as set forth in 37 CFR 3.11. Completion of this form is NOT a substitute for filing an assignment.

(A) NAME OF ASSIGNEE \_\_\_\_\_ (B) RESIDENCE: (CITY and STATE OR COUNTRY) \_\_\_\_\_

Please check the appropriate assignee category or categories (will not be printed on the patent) :  Individual  Corporation or other private group entity  Government

<p>4a. The following fee(s) are submitted:</p> <p><input type="checkbox"/> Issue Fee</p> <p><input type="checkbox"/> Publication Fee (No small entity discount permitted)</p> <p><input type="checkbox"/> Advance Order - # of Copies _____</p>	<p>4b. Payment of Fee(s): (<b>Please first reapply any previously paid issue fee shown above</b>)</p> <p><input type="checkbox"/> A check is enclosed.</p> <p><input type="checkbox"/> Payment by credit card. Form PTO-2038 is attached.</p> <p><input type="checkbox"/> The director is hereby authorized to charge the required fee(s), any deficiency, or credits any overpayment, to Deposit Account Number _____ (enclose an extra copy of this form).</p>
---	--

5. **Change in Entity Status** (from status indicated above)

Applicant certifying micro entity status. See 37 CFR 1.29

Applicant asserting small entity status. See 37 CFR 1.27

Applicant changing to regular undiscounted fee status.

**NOTE:** Absent a valid certification of Micro Entity Status (see forms PTO/SB/15A and 15B), issue fee payment in the micro entity amount will not be accepted at the risk of application abandonment.

**NOTE:** If the application was previously under micro entity status, checking this box will be taken to be a notification of loss of entitlement to micro entity status.

**NOTE:** Checking this box will be taken to be a notification of loss of entitlement to small or micro entity status, as applicable.

**NOTE:** This form must be signed in accordance with 37 CFR 1.31 and 1.33. See 37 CFR 1.4 for signature requirements and certifications.

Authorized Signature \_\_\_\_\_ Date \_\_\_\_\_

Typed or printed name \_\_\_\_\_ Registration No. \_\_\_\_\_



UNITED STATES PATENT AND TRADEMARK OFFICE

UNITED STATES DEPARTMENT OF COMMERCE
United States Patent and Trademark Office
Address: COMMISSIONER FOR PATENTS
P.O. Box 1450
Alexandria, Virginia 22313-1450
www.uspto.gov

Table with 5 columns: APPLICATION NO., FILING DATE, FIRST NAMED INVENTOR, ATTORNEY DOCKET NO., CONFIRMATION NO.
13/312,405 12/06/2011 David Brent Guard 080900.1371 6025

12323 7590 11/21/2014
Baker Botts L.L.P.
2001 Ross Avenue, 6th Floor
Dallas, TX 75201

EXAMINER

SAEED, AHMED M

ART UNIT PAPER NUMBER

2833

DATE MAILED: 11/21/2014

Determination of Patent Term Adjustment under 35 U.S.C. 154 (b)

(Applications filed on or after May 29, 2000)

The Office has discontinued providing a Patent Term Adjustment (PTA) calculation with the Notice of Allowance.

Section 1(h)(2) of the AIA Technical Corrections Act amended 35 U.S.C. 154(b)(3)(B)(i) to eliminate the requirement that the Office provide a patent term adjustment determination with the notice of allowance. See Revisions to Patent Term Adjustment, 78 Fed. Reg. 19416, 19417 (Apr. 1, 2013). Therefore, the Office is no longer providing an initial patent term adjustment determination with the notice of allowance. The Office will continue to provide a patent term adjustment determination with the Issue Notification Letter that is mailed to applicant approximately three weeks prior to the issue date of the patent, and will include the patent term adjustment on the patent. Any request for reconsideration of the patent term adjustment determination (or reinstatement of patent term adjustment) should follow the process outlined in 37 CFR 1.705.

Any questions regarding the Patent Term Extension or Adjustment determination should be directed to the Office of Patent Legal Administration at (571)-272-7702. Questions relating to issue and publication fee payments should be directed to the Customer Service Center of the Office of Patent Publication at 1-(888)-786-0101 or (571)-272-4200.

## OMB Clearance and PRA Burden Statement for PTOL-85 Part B

The Paperwork Reduction Act (PRA) of 1995 requires Federal agencies to obtain Office of Management and Budget approval before requesting most types of information from the public. When OMB approves an agency request to collect information from the public, OMB (i) provides a valid OMB Control Number and expiration date for the agency to display on the instrument that will be used to collect the information and (ii) requires the agency to inform the public about the OMB Control Number's legal significance in accordance with 5 CFR 1320.5(b).

The information collected by PTOL-85 Part B is required by 37 CFR 1.311. The information is required to obtain or retain a benefit by the public which is to file (and by the USPTO to process) an application. Confidentiality is governed by 35 U.S.C. 122 and 37 CFR 1.14. This collection is estimated to take 12 minutes to complete, including gathering, preparing, and submitting the completed application form to the USPTO. Time will vary depending upon the individual case. Any comments on the amount of time you require to complete this form and/or suggestions for reducing this burden, should be sent to the Chief Information Officer, U.S. Patent and Trademark Office, U.S. Department of Commerce, P.O. Box 1450, Alexandria, Virginia 22313-1450. DO NOT SEND FEES OR COMPLETED FORMS TO THIS ADDRESS. SEND TO: Commissioner for Patents, P.O. Box 1450, Alexandria, Virginia 22313-1450. Under the Paperwork Reduction Act of 1995, no persons are required to respond to a collection of information unless it displays a valid OMB control number.

### Privacy Act Statement

**The Privacy Act of 1974 (P.L. 93-579)** requires that you be given certain information in connection with your submission of the attached form related to a patent application or patent. Accordingly, pursuant to the requirements of the Act, please be advised that: (1) the general authority for the collection of this information is 35 U.S.C. 2(b)(2); (2) furnishing of the information solicited is voluntary; and (3) the principal purpose for which the information is used by the U.S. Patent and Trademark Office is to process and/or examine your submission related to a patent application or patent. If you do not furnish the requested information, the U.S. Patent and Trademark Office may not be able to process and/or examine your submission, which may result in termination of proceedings or abandonment of the application or expiration of the patent.

The information provided by you in this form will be subject to the following routine uses:

1. The information on this form will be treated confidentially to the extent allowed under the Freedom of Information Act (5 U.S.C. 552) and the Privacy Act (5 U.S.C. 552a). Records from this system of records may be disclosed to the Department of Justice to determine whether disclosure of these records is required by the Freedom of Information Act.
2. A record from this system of records may be disclosed, as a routine use, in the course of presenting evidence to a court, magistrate, or administrative tribunal, including disclosures to opposing counsel in the course of settlement negotiations.
3. A record in this system of records may be disclosed, as a routine use, to a Member of Congress submitting a request involving an individual, to whom the record pertains, when the individual has requested assistance from the Member with respect to the subject matter of the record.
4. A record in this system of records may be disclosed, as a routine use, to a contractor of the Agency having need for the information in order to perform a contract. Recipients of information shall be required to comply with the requirements of the Privacy Act of 1974, as amended, pursuant to 5 U.S.C. 552a(m).
5. A record related to an International Application filed under the Patent Cooperation Treaty in this system of records may be disclosed, as a routine use, to the International Bureau of the World Intellectual Property Organization, pursuant to the Patent Cooperation Treaty.
6. A record in this system of records may be disclosed, as a routine use, to another federal agency for purposes of National Security review (35 U.S.C. 181) and for review pursuant to the Atomic Energy Act (42 U.S.C. 218(c)).
7. A record from this system of records may be disclosed, as a routine use, to the Administrator, General Services, or his/her designee, during an inspection of records conducted by GSA as part of that agency's responsibility to recommend improvements in records management practices and programs, under authority of 44 U.S.C. 2904 and 2906. Such disclosure shall be made in accordance with the GSA regulations governing inspection of records for this purpose, and any other relevant (i.e., GSA or Commerce) directive. Such disclosure shall not be used to make determinations about individuals.
8. A record from this system of records may be disclosed, as a routine use, to the public after either publication of the application pursuant to 35 U.S.C. 122(b) or issuance of a patent pursuant to 35 U.S.C. 151. Further, a record may be disclosed, subject to the limitations of 37 CFR 1.14, as a routine use, to the public if the record was filed in an application which became abandoned or in which the proceedings were terminated and which application is referenced by either a published application, an application open to public inspection or an issued patent.
9. A record from this system of records may be disclosed, as a routine use, to a Federal, State, or local law enforcement agency, if the USPTO becomes aware of a violation or potential violation of law or regulation.

<b>Notice of Allowability</b>	<b>Application No.</b> 13/312,405	<b>Applicant(s)</b> GUARD ET AL.	
	<b>Examiner</b> AHMED SAEED	<b>Art Unit</b> 2833	<b>AIA (First Inventor to File) Status</b> No

**-- The MAILING DATE of this communication appears on the cover sheet with the correspondence address--**

All claims being allowable, PROSECUTION ON THE MERITS IS (OR REMAINS) CLOSED in this application. If not included herewith (or previously mailed), a Notice of Allowance (PTOL-85) or other appropriate communication will be mailed in due course. **THIS NOTICE OF ALLOWABILITY IS NOT A GRANT OF PATENT RIGHTS.** This application is subject to withdrawal from issue at the initiative of the Office or upon petition by the applicant. See 37 CFR 1.313 and MPEP 1308.

1.  This communication is responsive to RCE filed 9/5/14.  
 A declaration(s)/affidavit(s) under **37 CFR 1.130(b)** was/were filed on \_\_\_\_\_.
2.  An election was made by the applicant in response to a restriction requirement set forth during the interview on \_\_\_\_\_; the restriction requirement and election have been incorporated into this action.
3.  The allowed claim(s) is/are 1,4-10 and 13-19. As a result of the allowed claim(s), you may be eligible to benefit from the **Patent Prosecution Highway** program at a participating intellectual property office for the corresponding application. For more information, please see [http://www.uspto.gov/patents/init\\_events/oph/index.jsp](http://www.uspto.gov/patents/init_events/oph/index.jsp) or send an inquiry to [PPHfeedback@uspto.gov](mailto:PPHfeedback@uspto.gov).
4.  Acknowledgment is made of a claim for foreign priority under 35 U.S.C. § 119(a)-(d) or (f).

**Certified copies:**

- a)  All    b)  Some    \*c)  None of the:
1.  Certified copies of the priority documents have been received.
  2.  Certified copies of the priority documents have been received in Application No. \_\_\_\_\_.
  3.  Copies of the certified copies of the priority documents have been received in this national stage application from the International Bureau (PCT Rule 17.2(a)).

\* Certified copies not received: \_\_\_\_\_.

Applicant has THREE MONTHS FROM THE "MAILING DATE" of this communication to file a reply complying with the requirements noted below. Failure to timely comply will result in ABANDONMENT of this application.

**THIS THREE-MONTH PERIOD IS NOT EXTENDABLE.**

5.  CORRECTED DRAWINGS ( as "replacement sheets") must be submitted.  
 including changes required by the attached Examiner's Amendment / Comment or in the Office action of Paper No./Mail Date \_\_\_\_\_.  
**Identifying indicia such as the application number (see 37 CFR 1.84(c)) should be written on the drawings in the front (not the back) of each sheet. Replacement sheet(s) should be labeled as such in the header according to 37 CFR 1.121(d).**
6.  DEPOSIT OF and/or INFORMATION about the deposit of BIOLOGICAL MATERIAL must be submitted. Note the attached Examiner's comment regarding REQUIREMENT FOR THE DEPOSIT OF BIOLOGICAL MATERIAL.

**Attachment(s)**

- |  |   |
|--|---|
| <ol style="list-style-type: none"> <li>1. <input type="checkbox"/> Notice of References Cited (PTO-892)</li> <li>2. <input checked="" type="checkbox"/> Information Disclosure Statements (PTO/SB/08),<br/>Paper No./Mail Date _____</li> <li>3. <input type="checkbox"/> Examiner's Comment Regarding Requirement for Deposit of Biological Material</li> <li>4. <input type="checkbox"/> Interview Summary (PTO-413),<br/>Paper No./Mail Date _____</li> </ol> | <ol style="list-style-type: none"> <li>5. <input type="checkbox"/> Examiner's Amendment/Comment</li> <li>6. <input checked="" type="checkbox"/> Examiner's Statement of Reasons for Allowance</li> <li>7. <input type="checkbox"/> Other _____</li> </ol> |
|--|---|

The present application is being examined under the pre-AIA first to invent provisions.

***Continued Examination Under 37 CFR 1.114***

A request for continued examination under 37 CFR 1.114, including the fee set forth in 37 CFR 1.17(e), was filed in this application after final rejection. Since this application is eligible for continued examination under 37 CFR 1.114, and the fee set forth in 37 CFR 1.17(e) has been timely paid, the finality of the previous Office action has been withdrawn pursuant to 37 CFR 1.114. Applicant's submission filed on 9/5/2014 has been entered.

***Allowable Subject Matter***

Claims 1, 4-10, 13-18 and 19 allowed.

**Regarding claims 1, 10 and 19**, the prior art fails to teach or show, alone or in combination, the claimed switch device comprising a display separated from the second surface of the substrate by a second OCA and a second cover sheet such that at least a portion of the second cover sheet is positioned between the second surface of the substrate and the display.

***Conclusion***

Any inquiry concerning this communication or earlier communications from the examiner should be directed to AHMED SAEED whose telephone number is (571)270-7976. The examiner can normally be reached on M-F (8:30-5:30pm).

Art Unit: 2833

If attempts to reach the examiner by telephone are unsuccessful, the examiner's supervisor, Renee Luebke can be reached on 571-272-2009.

The fax phone number for the organization where this application or proceeding is assigned is 571-273-8300.

Information regarding the status of an application may be obtained from the Patent Application Information Retrieval (PAIR) system. Status information for published applications may be obtained from either Private PAIR or Public PAIR. Status information for unpublished applications is available through Private PAIR only. For more information about the PAIR system, see <http://pair-direct.uspto.gov>. Should you have questions on access to the Private PAIR system, contact the Electronic Business Center (EBC) at 866-217-9197 (toll-free). If you would like assistance from a USPTO Customer Service Representative or access to the automated information system, call 800-786-9199 (IN USA OR CANADA) or 571-272-1000.

/AHMED SAEED/  
Examiner, Art Unit 2833

*/renee luebke/*

Renee Luebke  
Supervisory Patent Examiner  
AU 2833



Doc code: IDS

Doc description: Information Disclosure Statement (IDS) Filed

Under the Paperwork Reduction Act of 1995, no persons are required to respond to a collection of information unless it contains a valid OMB control number.

PTO/SB/08a (07-09)  
 Approved for use through 07/31/2012. OMB 0651-0031  
 U.S. Patent and Trademark Office; U.S. DEPARTMENT OF COMMERCE

<b>INFORMATION DISCLOSURE STATEMENT BY APPLICANT</b> ( Not for submission under 37 CFR 1.99)	Application Number		13312405
	Filing Date		2011-12-06
	First Named Inventor	David B. Guard	
	Art Unit	2833	
	Examiner Name	Ahmed M. Saeed	
	Attorney Docket Number	080900.1371	

**U.S.PATENTS**

Examiner Initial*	Cite No	Patent Number	Kind Code <sup>1</sup>	Issue Date	Name of Patentee or Applicant of cited Document	Pages, Columns, Lines where Relevant Passages or Relevant Figures Appear
	1	7864503		2011-01-14	Yu-Huel Chang	
	2	8217902		2012-07-10	Ching-Yang Chang	
	3	8355006		2013-01-15	PARK ET AL.	
	4	8456444		2013-06-04	Ishizaki et al.	
	5	8797285		2014-08-05	Guard et al.	
	6	8723824		2014-05-13	Scott A. Myers	

If you wish to add additional U.S. Patent citation information please click the Add button.

**U.S.PATENT APPLICATION PUBLICATIONS**

Examiner Initial*	Cite No	Publication Number	Kind Code <sup>1</sup>	Publication Date	Name of Patentee or Applicant of cited Document	Pages, Columns, Lines where Relevant Passages or Relevant Figures Appear
-------------------	---------	--------------------	------------------------	------------------	---	--

<b>INFORMATION DISCLOSURE STATEMENT BY APPLICANT</b> ( Not for submission under 37 CFR 1.99)	Application Number		13312405	
	Filing Date		2011-12-06	
	First Named Inventor	David B. Guard		
	Art Unit		2833	
	Examiner Name	Ahmed M. Saeed		
	Attorney Docket Number		080900.1371	

1	20080309635	2008-12-18	Mitsumi Matsuo
---	-------------	------------	----------------

If you wish to add additional U.S. Published Application citation information please click the Add button.

**FOREIGN PATENT DOCUMENTS**

Examiner Initial*	Cite No	Foreign Document Number <sup>3</sup>	Country Code <sup>2j</sup>	Kind Code <sup>4</sup>	Publication Date	Name of Patentee or Applicant of cited Document	Pages, Columns, Lines where Relevant Passages or Relevant Figures Appear	T <sup>5</sup>
	1							<input type="checkbox"/>

If you wish to add additional Foreign Patent Document citation information please click the Add button

**NON-PATENT LITERATURE DOCUMENTS**

Examiner Initials*	Cite No	Include name of the author (in CAPITAL LETTERS), title of the article (when appropriate), title of the item (book, magazine, journal, serial, symposium, catalog, etc), date, pages(s), volume-issue number(s), publisher, city and/or country where published.	T <sup>5</sup>
	1	Guard et al., USSN 13/312,405 Notice of Allowance dated March 27, 2014 (Atty Docket 080900.1208).	<input type="checkbox"/>
	2	Guard et al., USSN 13/312,405 Issue Notification dated July 16, 2014 (Atty Docket 080900.1208).	<input type="checkbox"/>
	3	Guard et al., USSN 13/331,022 Final Office Action dated April 15, 2014 (Atty Docket 080900.1370).	<input type="checkbox"/>
	4	Guard et al., USSN 13/331,022 Request for Continued Examination dated July 15, 2014 (Atty Docket 080900.1370).	<input type="checkbox"/>
	5	Guard et al., USSN 13/347,859 Appeal Brief dated March 28, 2014 (Atty Docket 080900.1424).	<input type="checkbox"/>

<b>INFORMATION DISCLOSURE STATEMENT BY APPLICANT</b> ( Not for submission under 37 CFR 1.99)	Application Number		13312405
	Filing Date		2011-12-06
	First Named Inventor	David B. Guard	
	Art Unit		2833
	Examiner Name	Ahmed M. Saeed	
	Attorney Docket Number		080900.1371

6	Guard et al., USSN 13/347,859 Examiner's Answer dated July 17, 2014 (Atty Docket 080900.1424).	<input type="checkbox"/>
7	Guard et al., USSN 13/413,306 Final Office Action dated April 11, 2014 (Atty Docket 080900.1425).	<input type="checkbox"/>
8	Guard et al., USSN 13/413,306 Request for Continued Examination dated July 11, 2014 (Atty Docket 080900.1425).	<input type="checkbox"/>

If you wish to add additional non-patent literature document citation information please click the Add button

**EXAMINER SIGNATURE**

Examiner Signature	/Ahmed Saeed/	Date Considered	11/13/2014
--------------------	---------------	-----------------	------------

\*EXAMINER: Initial if reference considered, whether or not citation is in conformance with MPEP 609. Draw line through a citation if not in conformance and not considered. Include copy of this form with next communication to applicant.

<sup>1</sup> See Kind Codes of USPTO Patent Documents at [www.USPTO.GOV](http://www.USPTO.GOV) or MPEP 901.04. <sup>2</sup> Enter office that issued the document, by the two-letter code (WIPO Standard ST.3). <sup>3</sup> For Japanese patent documents, the indication of the year of the reign of the Emperor must precede the serial number of the patent document. <sup>4</sup> Kind of document by the appropriate symbols as indicated on the document under WIPO Standard ST.16 if possible. <sup>5</sup> Applicant is to place a check mark here if English language translation is attached.



UNITED STATES PATENT AND TRADEMARK OFFICE

UNITED STATES DEPARTMENT OF COMMERCE  
 United States Patent and Trademark Office  
 Address: COMMISSIONER FOR PATENTS  
 P.O. Box 1450  
 Alexandria, Virginia 22313-1450  
 www.uspto.gov

BIB DATA SHEET

CONFIRMATION NO. 6025

<b>SERIAL NUMBER</b> 13/312,405	<b>FILING or 371(c) DATE</b> 12/06/2011 <b>RULE</b>	<b>CLASS</b> 200	<b>GROUP ART UNIT</b> 2833	<b>ATTORNEY DOCKET NO.</b> 080900.1371	
<b>APPLICANTS</b> <b>INVENTORS</b> David Brent Guard, Hampshire, UNITED KINGDOM; Esat Yilmaz, Santa Cruz, CA; Tsung-Ching Wu, Saratoga, CA; <b>** CONTINUING DATA *****</b> This application is a CON of 13/089,061 04/18/2011 PAT 8797285 <b>** FOREIGN APPLICATIONS *****</b> <b>** IF REQUIRED, FOREIGN FILING LICENSE GRANTED **</b> 12/16/2011					
Foreign Priority claimed <input type="checkbox"/> Yes <input checked="" type="checkbox"/> No 35 USC 119(a-d) conditions met <input type="checkbox"/> Yes <input checked="" type="checkbox"/> No Verified and Acknowledged <u>/AHMED M SAEED/</u> Examiner's Signature	<input type="checkbox"/> Met after Allowance Initials _____	<b>STATE OR COUNTRY</b> UNITED KINGDOM	<b>SHEETS DRAWINGS</b> 9	<b>TOTAL CLAIMS</b> 20	<b>INDEPENDENT CLAIMS</b> 3
<b>ADDRESS</b> Baker Botts L.L.P. 2001 Ross Avenue, 6th Floor Dallas, TX 75201 UNITED STATES					
<b>TITLE</b> Two-Layer Sensor Stack					
<b>FILING FEE RECEIVED</b> 1250	FEES: Authority has been given in Paper No. _____ to charge/credit DEPOSIT ACCOUNT No. _____ for following:		<input type="checkbox"/> All Fees <input type="checkbox"/> 1.16 Fees (Filing) <input type="checkbox"/> 1.17 Fees (Processing Ext. of time) <input type="checkbox"/> 1.18 Fees (Issue) <input type="checkbox"/> Other _____ <input type="checkbox"/> Credit		



<b>Issue Classification</b> 	<b>Application/Control No.</b> 13312405	<b>Applicant(s)/Patent Under Reexamination</b> GUARD ET AL.
	<b>Examiner</b> AHMED SAEED	<b>Art Unit</b> 2833

US ORIGINAL CLASSIFICATION				INTERNATIONAL CLASSIFICATION									
CLASS		SUBCLASS		CLAIMED				NON-CLAIMED					
200		181		H	0	3	K	17 / 96 (2006.0)					
<b>CROSS REFERENCE(S)</b>													
CLASS	SUBCLASS (ONE SUBCLASS PER BLOCK)												
345	172												

/AHMED SAEED/ Examiner, Art Unit 2833  (Assistant Examiner)	11/13/2014  (Date)	<b>Total Claims Allowed:</b>  15	
/renee luebke/ SPE - AU 2833  (Primary Examiner)	11/17/14  (Date)	O.G. Print Claim(s)  1	O.G. Print Figure  1

<b>Issue Classification</b> 	<b>Application/Control No.</b> 13312405	<b>Applicant(s)/Patent Under Reexamination</b> GUARD ET AL.
	<b>Examiner</b> AHMED SAEED	<b>Art Unit</b> 2833

<input type="checkbox"/> <b>Claims renumbered in the same order as presented by applicant</b>																<input type="checkbox"/> <b>CPA</b>		<input type="checkbox"/> <b>T.D.</b>		<input type="checkbox"/> <b>R.1.47</b>	
Final	Original	Final	Original	Final	Original	Final	Original	Final	Original	Final	Original	Final	Original	Final	Original						
1	1	13	17																		
-	2	14	18																		
-	3	15	19																		
2	4	-	20																		
3	5																				
4	6																				
5	7																				
6	8																				
7	9																				
8	10																				
-	11																				
-	12																				
9	13																				
10	14																				
11	15																				
12	16																				

/AHMED SAEED/ Examiner, Art Unit 2833  (Assistant Examiner)	11/13/2014  (Date)	<b>Total Claims Allowed:</b>  15	
/renee luebke/ SPE - AU 2833  (Primary Examiner)	11/17/14  (Date)	O.G. Print Claim(s)  1	O.G. Print Figure  1

<b>Search Notes</b>  	<b>Application/Control No.</b>  13312405	<b>Applicant(s)/Patent Under Reexamination</b>  GUARD ET AL.
	<b>Examiner</b>  AHMED SAEED	<b>Art Unit</b>  2833

<b>CPC- SEARCHED</b>		
<b>Symbol</b>	<b>Date</b>	<b>Examiner</b>
H01H13/702 OR H01H2239/006	11/13/2014	AS

<b>CPC COMBINATION SETS - SEARCHED</b>		
<b>Symbol</b>	<b>Date</b>	<b>Examiner</b>

<b>US CLASSIFICATION SEARCHED</b>			
<b>Class</b>	<b>Subclass</b>	<b>Date</b>	<b>Examiner</b>

<b>SEARCH NOTES</b>		
<b>Search Notes</b>	<b>Date</b>	<b>Examiner</b>
Inventor name search	11/13/2014	AS
consult with Renee Luebke	11/13/2014	AS
EAST text search with subclasses (200/512, 345/173, 428, 361)	11/13/2014	AS

<b>INTERFERENCE SEARCH</b>			
<b>US Class/ CPC Symbol</b>	<b>US Subclass / CPC Group</b>	<b>Date</b>	<b>Examiner</b>
see EAST search		11/13/2014	AS

--	--



## EAST Search History

## EAST Search History (Prior Art)

Ref #	Hits	Search Query	DBs	Default Operator	Plurals	Time Stamp
L3	1	"13312405"	US-PGPUB; USPAT; DERWENT	ADJ	ON	2014/11/13 17:41
L4	1901	(( H01H13/702 OR H01H2239/006).CPC. )	US-PGPUB; USPAT; DERWENT	ADJ	ON	2014/11/13 17:47
S19	1309	atmel corporation.as.	US-PGPUB; USPAT; USOCR; FPRS; EPO; JPO; DERWENT; IBM_TDB	ADJ	ON	2013/07/03 13:36
S20	24	atmel corporation.as. and adhes\$3 (layer or sheet)	US-PGPUB; USPAT; USOCR; FPRS; EPO; JPO; DERWENT; IBM_TDB	ADJ	ON	2013/07/03 13:36
S22	10146	first (surface or face) same substrate and electrode and adhes\$3	US-PGPUB; USPAT; USOCR; FPRS; EPO; JPO; DERWENT; IBM_TDB	ADJ	ON	2013/07/03 13:45
S23	3134	first (surface or face) near substrate and electrode and adhes\$3 and second (surface or face)	US-PGPUB; USPAT; USOCR; FPRS; EPO; JPO; DERWENT; IBM_TDB	ADJ	ON	2013/07/03 13:46
S24	1799	first (surface or face) near substrate and electrode and adhes\$3 and second (surface or face) near substrate	US-PGPUB; USPAT; USOCR; FPRS; EPO; JPO; DERWENT; IBM_TDB	ADJ	ON	2013/07/03 13:46
S25	69	first (surface or face) near substrate and electrode and second adhes\$3 and second (surface or face) near substrate	US-PGPUB; USPAT; USOCR; FPRS; EPO; JPO; DERWENT; IBM_TDB	ADJ	ON	2013/07/03 13:47
S35	705	(display or panel) near substrate with dielectric layer	US-PGPUB; USPAT;	ADJ	ON	2013/07/03 17:31

PETITIONERS

Exhibit 1003, Page 29

			USOCR; FPRS; EPO; JPO; DERWENT; IBM_TDB			
S36	594	(display or panel) near substrate with dielectric layer and electrode	US-PGPUB; USPAT; USOCR; FPRS; EPO; JPO; DERWENT; IBM_TDB	ADJ	ON	2013/07/03 17:32
S41	222	(optical or clear or transparent) adhesive layer and (display or screen) and substrate and (cover or case)	US-PGPUB; USPAT; USOCR; FPRS; EPO; JPO; DERWENT; IBM_TDB	ADJ	ON	2013/07/08 10:44
S42	29	(optical or clear or transparent) adhesive layer and (display or screen) and substrate and (cover or case) and dielectric (layer or sheet)	US-PGPUB; USPAT; USOCR; FPRS; EPO; JPO; DERWENT; IBM_TDB	ADJ	ON	2013/07/08 10:45
S43	3235	345/174.ccls.	US-PGPUB; USPAT; USOCR; FPRS; EPO; JPO; DERWENT; IBM_TDB	ADJ	ON	2013/07/08 11:22
S44	14517	345/173.ccls.	US-PGPUB; USPAT; USOCR; FPRS; EPO; JPO; DERWENT; IBM_TDB	ADJ	ON	2013/07/08 11:23
S45	3624	345/173.ccls. and (micromillimeter or m)	US-PGPUB; USPAT; USOCR; FPRS; EPO; JPO; DERWENT; IBM_TDB	ADJ	ON	2013/07/08 11:25
S46	0	first (surface or face) near substrate and electrode and adhes\$3 and second (surface or face) near substrate and micromillimeter	US-PGPUB; USPAT; USOCR; FPRS; EPO; JPO; DERWENT; IBM_TDB	ADJ	ON	2013/07/08 11:25
S47	216	first (surface or face) near substrate and electrode and adhes\$3 and second (surface or face) near substrate and micrometer	US-PGPUB; USPAT; USOCR; FPRS; EPO; JPO; DERWENT; IBM_TDB	ADJ	ON	2013/07/08 11:29

PETITIONERS

Exhibit 1003, Page 30

S48	2	2009/0153507	US-PGPUB; USPAT; USOCR; FPRS; EPO; JPO; DERWENT; IBM_TDB	ADJ	ON	2013/07/08 11:57
S50	140	345/173.ccls. and (micromillimeter or m) and sinusoidal	US-PGPUB; USPAT; USOCR; FPRS; EPO; JPO; DERWENT; IBM_TDB	ADJ	ON	2013/07/08 12:10
S51	0	2011/0310033	US-PGPUB; USPAT; USOCR; FPRS; EPO; JPO; DERWENT; IBM_TDB	ADJ	ON	2013/07/08 14:25
S52	2	"20110310033"	US-PGPUB; USPAT; USOCR; FPRS; EPO; JPO; DERWENT; IBM_TDB	ADJ	ON	2013/07/08 14:25
S53	41	("7920129"   "20120242588"   "8040326"   "20020167619"   "20060097991"   "7663607"   "8031174" "8049732"   "20100302201"   "20090315854"   "20110310037"   "20100045632"   "20120242592"   "20120243151"   "8179381"   "20130076612"   "8031094"   "20110310033"   "20120243719"   "7875814"   "20110007020").PN.	US-PGPUB; USPAT; USOCR; FPRS; EPO; JPO; DERWENT; IBM_TDB	ADJ	ON	2013/07/08 14:30
S54	16	("20090315854"   "20120242588"   "20120242592"   "20120243151"   "20120243719"   "7875814"   "8040326" "8179381").PN.	US-PGPUB; USPAT; USOCR; FPRS; EPO; JPO; DERWENT; IBM_TDB	ADJ	ON	2013/07/08 14:42
S55	0	345/173.ccls. and conductive mesh and S43 (percent or 5%)	US-PGPUB; USPAT; USOCR; FPRS; EPO; JPO; DERWENT; IBM_TDB	ADJ	ON	2013/07/08 15:09
S56	10	345/173.ccls. and conductive mesh and (S43 percent or 5%)	US-PGPUB; USPAT; USOCR; FPRS; EPO; JPO; DERWENT; IBM_TDB	ADJ	ON	2013/07/08 15:09
S57	1091	200/512.ccls.	US-PGPUB; USPAT;	ADJ	ON	2013/07/08 17:11

PETITIONERS

Exhibit 1003, Page 31

			USOCR; FPRS; EPO; JPO; DERWENT; IBM_TDB			
S58	41	("7920129"   "20120242588"   "8040326"   "20020167619"   "20060097991"   "7663607"   "8031174"   "8049732"   "20100302201"   "20090315854"   "20110310037"   "20100045632"   "20120242592"   "20120243151"   "8179381"   "20130076612"   "8031094"   "20110310033"   "20120243719"   "7875814"   "20110007020").PN.	US-PGPUB; USPAT; USOCR; FPRS; EPO; JPO; DERWENT; IBM_TDB	ADJ	ON	2013/07/11 17:20
S59	16	2008/0158183	US-PGPUB; USPAT; USOCR; FPRS; EPO; JPO; DERWENT; IBM_TDB	ADJ	ON	2013/07/11 17:23
S60	3	"7920129".pn.	US-PGPUB; USPAT; USOCR; FPRS; EPO; JPO; DERWENT; IBM_TDB	ADJ	ON	2013/07/11 17:32
S61	97	("20030231168"   "20060026521"   "20060084852"   "20060092142"   "20060097991"   "20060197753"   "20080088595"   "5483261"   "5488204"   "5825352"   "5835079"   "5869791"   "5880411"   "5942733"   "6188391"   "6310610"   "6323846"   "6690387"   "6970160"   "7015894"   "7184064"   "7382139"   "7511702"   "7532205"   "7663607").PN. OR ("7920129").URPN.	US-PGPUB; USPAT; USOCR	ADJ	ON	2014/02/12 16:27
S62	65	("7920129"   "8040326"   "20120242588"   "20060281297"   "20080170819"   "20090217518"   "6555762"   "20060115983"   "20120013544"   "20120113014"   "20060169485"   "4967314"   "6009620"   "6889433"   "20100038778"   "20060220245"   "20080105456"   "5972482"   "6337037"   "6534723"   "7772118"   "20080186288"   "20120127079"   "7663607"   "8031174"   "8049732"   "20090315854"   "20090145651"   "20020045394"   "20060272850"   "5117069"   "20090236151"   "20090237365"   "20110049646"   "20110210935"   "20120062472"   "8179381"   "20120242592"   "20120243151"   "20060284300"   "6211487"   "6584682"   "8031094"   "7875814"   "20120243719"   "20070026196"   "20100183920"   "4383363"   "5638598"   "6570102"   "20070178279"	US-PGPUB; USPAT; USOCR	ADJ	ON	2014/02/12 16:30

PETITIONERS

Exhibit 1003, Page 32

		"7874066"   "20050083307"   "20050196710"   "20070281387"   "20080192001"   "20090242283"   "20120139864"   "8343790"   "20020171065"   "20040214422"   "20080289859"   "6326694"   "20090085152"   "8440916").PN.				
S63	22	("7920129"   "8040326"   "20110215914"   "20120242588"   "20110193819"   "20090273573"   "20100156845"   "7663607"   "8031174"   "8049732"   "20090315854"   "20110141052"   "20080158178"   "8179381"   "20100123677"   "20120242592"   "20120243151"   "8031094"   "7875814"   "20120243719"   "20060158433"   "20110273396").PN.	US-PGPUB; USPAT; USOCR	ADJ	ON	2014/02/12 16:46
S64	1	second cover same (OCA or optical\$2 clear adhes\$3) and substrate	US-PGPUB; USPAT; USOCR	ADJ	ON	2014/02/12 16:48
S65	383	cover same (OCA or optical\$2 clear adhes\$3) and substrate	US-PGPUB; USPAT; USOCR	ADJ	ON	2014/02/12 16:49
S66	1	"13347859"	US-PGPUB; USPAT; USOCR	ADJ	ON	2014/02/12 19:49
S67	1	"20110310033"	US-PGPUB; USPAT; USOCR	ADJ	ON	2014/02/12 19:50
S68	1	"13331022"	US-PGPUB; USPAT; USOCR	ADJ	ON	2014/02/12 19:53
S69	1	"13312405"	US-PGPUB; USPAT; USOCR	ADJ	ON	2014/02/12 19:54
S70	1	"13413306"	US-PGPUB; USPAT; USOCR	ADJ	ON	2014/02/12 19:57
S71	1	"13347859"	US-PGPUB; USPAT; USOCR	ADJ	ON	2014/02/12 19:57
S72	3	"13089061"	US-PGPUB; USPAT; USOCR	ADJ	ON	2014/02/12 19:59
S73	938	200/512.ccls.	US-PGPUB; USPAT; USOCR	ADJ	ON	2014/02/12 20:01
S74	4	345/174.ccls. and second cover	US-PGPUB; USPAT; USOCR; FPRS; EPO; JPO; DERWENT; IBM_TDB	ADJ	ON	2014/02/12 20:03
S75	0	345/174.ccls. and s(econd or upper or lower) cover	US-PGPUB; USPAT; USOCR; FPRS; EPO; JPO;	ADJ	ON	2014/02/12 20:06

PETITIONERS

Exhibit 1003, Page 33

			DERWENT; IBM_TDB			
S76	23	345/174.ccls. and (second or upper or lower) cover	US-PGPUB; USPAT; USOCR; FPRS; EPO; JPO; DERWENT; IBM_TDB	ADJ	ON	2014/02/12 20:06
S77	18	("20130063393"   "20090073085"   "20130033452"   "20100136265"   "20110001720"   "20110151201").PN.	US-PGPUB; USPAT; USOCR; FPRS; EPO; JPO; DERWENT; IBM_TDB	ADJ	ON	2014/02/12 20:08
S78	1	"428".clas. and second (OCA or optical\$2 clear adhes\$2)	US-PGPUB; USPAT; USOCR; FPRS; EPO; JPO; DERWENT; IBM_TDB	ADJ	ON	2014/02/24 10:20
S79	155	"428".clas. and (OCA or optical\$2 clear adhes\$2)	US-PGPUB; USPAT; USOCR; FPRS; EPO; JPO; DERWENT; IBM_TDB	ADJ	ON	2014/02/24 10:22
S80	475	"428".clas. and second (cover)	US-PGPUB; USPAT; USOCR; FPRS; EPO; JPO; DERWENT; IBM_TDB	ADJ	ON	2014/02/24 10:37
S81	15	"428".clas. and second (cover) same (display or screen)	US-PGPUB; USPAT; USOCR; FPRS; EPO; JPO; DERWENT; IBM_TDB	ADJ	ON	2014/02/24 10:38
S82	41	("20020145801"   "20020192397"   "20030096093"   "20030214715"   "20030215581"   "20030215582"   "20030215583"   "20030215608"   "20030215621"   "20030215658"   "20050249932"   "20050249944"   "20050249962"   "20060108065"   "20060110549"   "20060144514"   "20060187548"   "20060225827"   "20060225831"   "20060234035"   "20070272354"   "2524286"   "4626304"   "4735854"   "5219510"   "5753140"   "5976297"   "6068794"   "6245382"   "6693746"   "6746732"   "6840635"   "6913820"   "7252733"   "7279060"   "7399376").PN. OR ("7662456").URPN.	US-PGPUB; USPAT; USOCR	ADJ	ON	2014/02/24 10:51
S83	117	(LCD or touch panel or touch screen or	US-PGPUB;	ADJ	ON	2014/02/24

PETITIONERS

Exhibit 1003, Page 34

		Liquid Crystal Displays) and second cover same (display or screen) and adhes\$3	USPAT; USOCR			11:29
S84	52	(LCD or touch panel or touch screen or Liquid Crystal Displays) and second cover same (display or screen) and adhes\$3 and substrate	US-PGPUB; USPAT; USOCR	ADJ	ON	2014/02/24 11:30
S85	1	"6924789".pn.	US-PGPUB; USPAT; USOCR	ADJ	ON	2014/02/24 11:55
S86	29	("20120242588"   "8040326"   "20040239650"   "20120262412"   "20080158183"   "6924789"   "20020167619"   "20060097991"   "20090205879"   "20090273570"   "20120075238"   "20130234974"   "7382139"   "20100045614"   "20100302201"   "20110310037"   "20120262382"   "20120242592"   "20120243151"   "8179381"   "20130076612"   "20100045632"   "20130127772"   "20090135854"   "20120243719"   "7875814"   "20090219257"   "20110310033"   "20100045615").PN.	US-PGPUB; USPAT; USOCR	ADJ	ON	2014/02/24 11:56
S87	40	((DAVID) near2 (GUARD)).INV.	US-PGPUB; USPAT; USOCR	ADJ	ON	2014/02/24 12:45
S89	71	"361".clas. and (optical\$2 clear adhes\$2 or OCA)	US-PGPUB; USPAT; USOCR; FPRS; EPO; JPO; DERWENT; IBM_TDB	ADJ	ON	2014/02/24 14:05
S90	346	"345".clas. and (optical\$2 clear adhes\$2 or OCA)	US-PGPUB; USPAT; USOCR; FPRS; EPO; JPO; DERWENT; IBM_TDB	ADJ	ON	2014/02/24 14:21
S91	216	"345".clas. and (optical\$2 clear adhes\$2 or OCA) same (display or screen or LCD)	US-PGPUB; USPAT; USOCR; FPRS; EPO; JPO; DERWENT; IBM_TDB	ADJ	ON	2014/02/24 14:21
S92	2	"345".clas. and second (optical\$2 clear adhes\$2 or OCA) same (display or screen or LCD)	US-PGPUB; USPAT; USOCR; FPRS; EPO; JPO; DERWENT; IBM_TDB	ADJ	ON	2014/02/24 14:21
S93	106	second (cover or coat or protect\$3 or flim or layer or sheet) near5 (display or screen or LCD) same (optical\$2 clear adhes\$2 or OCA)	US-PGPUB; USPAT; USOCR; FPRS; EPO; JPO;	ADJ	ON	2014/02/24 14:38

PETITIONERS

Exhibit 1003, Page 35

			DERWENT; IBM_TDB			
S94	119	second (cover or coat or protect\$3 or flim or layer or sheet) same (display or screen or LCD) same (optical\$2 clear adhes\$2 or OCA)	US-PGPUB; USPAT; USOCR; FPRS; EPO; JPO; DERWENT; IBM_TDB	ADJ	ON	2014/02/24 14:41
S95	13	S94 not S93	US-PGPUB; USPAT; USOCR; FPRS; EPO; JPO; DERWENT; IBM_TDB	ADJ	ON	2014/02/24 14:42
S96	44	("20010046081"   "20040041967"   "20040108193"   "5675361"   "5887995"   "5988902"   "6224278"   "6288707"   "6498600"   "6680731").PN. OR ("6924789").URPN.	US-PGPUB; USPAT; USOCR	ADJ	ON	2014/02/24 14:57
S97	547	("20010000961"   "20010020578"   "20010020986"   "20010020987"   "20020015024"   "20020041356"   "20020049070"   "20020084922"   "20020089496"   "20020101410"   "20020118848"   "20020140649"   "20020159015"   "20020167489"   "20020185981"   "20020185999"   "20020186210"   "20020190964"   "20020191029"   "20020192445"   "20020196237"   "20030006974"   "20030035479"   "20030067451"   "20030069653"   "20030076301"   "20030076303"   "20030076306"   "20030085882"   "20030095095"   "20030095096"   "20030098858"   "20030151600"   "20030174128"   "20030179323"   "20030201984"   "20030206162"   "20030206202"   "20030222857"   "20030234768"   "20030234769"   "20030234770"   "20040022010"   "20040056839"   "20040080501"   "20040090429"   "20040095335"   "20040109097"   "20040119701"   "20040141096"   "20040150629"   "20040155871"   "20040155991"   "20040165005"   "20040183076"   "20040188150"   "20040189587"   "20040189612"   "20040217945"   "20040227736"   "20040239650"   "20040243747"   "20040263484"   "20050007349"   "20050012723"   "20050017737"   "20050046621"   "20050052425"   "20050052427"   "20050052582"   "20050062620"   "20050073507"   "20050083307"   "20050099402"   "20050104867"   "20050110768"   "20050146511"   "20050162402"   "20050170668"   "20050231487"   "20050237439"   "20050243023"   "20060007087"   "20060007165")	US-PGPUB; USPAT; USOCR	ADJ	ON	2014/02/24 14:59

PETITIONERS

Exhibit 1003, Page 36



"20060012575"	"20060017710"
"20060022955"	"20060022956"
"20060026521"	"20060026535"
"20060026536"	"20060032680"
"20060033724").PN. OR ("20060044259"	
"20060053387"   "20060066582"	
"20060085757"   "20060097991"	
"20060109222"   "20060132462"	
"20060145365"   "20060145983"	
"20060146033"   "20060146034"	
"20060197753"   "20060227114"	
"20060232564"   "20060232567"	
"20060238517"   "20060238518"	
"20060238519"   "20060238520"	
"20060238521"   "20060238522"	
"20060244736"   "20060278444"	
"20060279679"   "20060290863"	
"20070013678"   "20070018969"	
"20070027932"   "20070062739"	
"20070075977"   "20070085838"	
"20070109274"   "20070152976"	
"20070159561"   "20070176905"	
"20070182706"   "20070216657"	
"20070229464"   "20070236466"	
"20070247429"   "20070257890"	
"20070262967"   "20080048994"	
"20080055221"   "20080055268"	
"20080055270"   "20080062139"	
"20080062140"   "20080062147"	
"20080062148"   "20080067528"	
"20080074401"   "20080079697"	
"20080129317"   "20080129898"	
"20080131624"   "20080136980"	
"20080150901"   "20080157867"	
"20080158167"   "20080158181"	
"20080165158"   "20080186288"	
"20080297476"   "20090066670"	
"20090090694"   "20090096757"	
"20090096758"   "20090115743"	
"20090160816"   "20090273581"	
"20090303193"   "20100103121"	
"20100188347"   "20100194698"	
"20100238134"   "20100289770"	
"20110187677"   "20120105371"	
"20120162104"   "20120162584"	
"2751555"   "3333160"   "3541541"	
"3644835"   "3662105"   "3798370"	
"3974332"   "4194083"   "4233522"	
"4246452"   "4250495"   "4266144"	
"4268815"   "4277517"   "4290052"	
"4307383"   "4313108").PN. OR	
("4345000"   "4363027"   "4394643"	
"4526043"   "4550221"   "4587378"	
"4618989"   "4623757"   "4639720"	
"4672364"   "4672558"   "4686332"	
"4692809"   "4695827"   "4707845"	
"4723056"   "4733222"   "4734685"	
"4740781"   "4746770"   "4771276"	
"4772885"   "4788384"   "4806709"	
"4806846"   "4853493"   "4898555"	
"4910504"   "4914624"   "4916308"	
"4954823"   "4968877"   "5003519"	
"5017030"   "5062198"   "5073950"	
"5105186"   "5105288"   "5113041"	

PETITIONERS

Exhibit 1003, Page 37

"5117071"	"5178477"	"5189403"
"5194862"	"5224861"	"5239152"
"5241308"	"5252951"	"5281966"
"5293430"	"5305017"	"5345543"
"5353135"	"5374787"	"5376948"
"5381160"	"5386219"	"5392058"
"5398310"	"5432671"	"5442742"
"5457289"	"5459463"	"5463388"
"5463696"	"5483261"	"5488204"
"5495077"	"5499026"	"5513309"
"5523775"	"5530455"	"5534892"
"5543588"	"5543589"	"5543590"
"5543591"	"5550659"	"5552787"
"5563632"	"5563727"	"5563996"
"5565658"	"5572205"	"5576070"
"5579036"	"5581681"	"5583946"
"5589856"	"5590219"	"5592566"
"5594806"	"5594810"	"5596694"
"5612719"	"5623280"	"5631805"
"5633955"	"5634102"	"5636101"
"5638093"	"5642108"	"5644657"
"5648642"	"5650597"	"5666113"
"5666502"	"5666552"	"5675361"
"5677710"	"5677744"	"5689253"
"5710844"	"5729250"	"5730165"
"5734742"	"5734751"	"5736976"
"5741990"	"5745116"	"5745716"
"5748269"	"5764218"	"5764818"
"5767457"	"5767842")	PN. OR
("5777596"	"5790104"	"5790106"
"5790107"	"5802516"	"5805144"
"5808567"	"5809166"	"5809267"
"5815141"	"5821690"	"5821930"
"5823782"	"5825351"	"5825352"
"5835079"	"5838308"	"5841078"
"5841415"	"5844506"	"5847690"
"5852487"	"5854450"	"5854625"
"5856822"	"5861583"	"5861875"
"5867151"	"5869790"	"5869791"
"5880411"	"5898434"	"5914465"
"5917165"	"5920298"	"5920309"
"5923319"	"5929834"	"5933134"
"5940055"	"5940064"	"5942733"
"5943043"	"5943044"	"5945980"
"5952998"	"5955198"	"5982352"
"6002389"	"6002808"	"6008800"
"6020881"	"6020945"	"6023265"
"6028581"	"6029214"	"6031524"
"6037882"	"6050825"	"6052339"
"6057903"	"6061177"	"6072494"
"6081259"	"6084576"	"6107654"
"6107997"	"6124848"	"6128003"
"6131299"	"6135958"	"6137427"
"6144380"	"6163313"	"6172667"
"6177918"	"6188391"	"6191828"
"6198515"	"6204897"	"6208329"
"6211585"	"6222465"	"6239389"
"6239788"	"6239790"	"6243071"
"6246862"	"6249606"	"6259490"
"6271835"	"6285428"	"6288707"
"6289326"	"6292178"	"6297811"
"6310610"	"6323846"	"6323849"
"6337678"	"6342938"	"6347290"
"6377009"	"6380931"	"6411287"

PETITIONERS

Exhibit 1003, Page 38

		"6414671"   "6417846"   "6421039"   "6421234"   "6425289"   "6452514"   "6457355"   "6459424"   "6466036"   "6483498"   "6501528"   "6501529"   "6504530"   "6504713"   "6515669"   "6522772"   "6525547"   "6525749"   "6535200"   "6543684").PN. OR ("6543947"   "6549193"   "6570557"   "6593916"   "6602790"   "6610936"   "6624833"   "6624835"   "6628268"   "6639577"   "6650319"   "6658994"   "6670894"   "6677932"   "6677934"   "6680448"   "6690387"   "6721375"   "6723929"   "6724366"   "6757002"   "6762752"   "6784948"   "6785578"   "6803906"   "6825833"   "6842672"   "6846579"   "6856259"   "6876355"   "6888536"   "6900795"   "6906692"   "6924789"   "6927761"   "6927763"   "6942571"   "6943779"   "6961049"   "6965375"   "6970160"   "6972401"   "6977666"   "6982432"   "6985801"   "6992659"   "6995752"   "7015894"   "7023427"   "7030860"   "7031228"   "7038659"   "7042444"   "7046235"   "7088342"   "7088343"   "7098127"   "7098897"   "7109978"   "7129935"   "7133032"   "7138984"   "7151528"   "7154481"   "7177001"   "7184064"   "7190416"   "7202856"   "7230608"   "7254775"   "7268770"   "7274353"   "7280167"   "7292229"   "7307231"   "7339579"   "7355592"   "7362313"   "7372455"   "7379054"   "7453444"   "7463246"   "7483016"   "7554624"   "7633484"   "7663607"   "7688315"   "7705834"   "7730401"   "7746326"   "7800589"   "7812828"   "7843439"   "7920129"   "8125463"   "8243027"   "8259078"   "D482368"   "RE40153").PN. OR ("8432371").URPN.				
S99	7436	(optical\$2 clear adhes\$2 or OCA) and (display or screen or OCA)	US-PGPUB; USPAT; USOCR; FPRS; EPO; JPO; DERWENT; IBM_TDB	ADJ	ON	2014/02/24 15:02
S103	1	"13312405"	US-PGPUB; USPAT; USOCR	ADJ	ON	2014/11/07 12:57
S104	48	((David) near2 (Guard)).INV.	US-PGPUB; USPAT; USOCR	ADJ	ON	2014/11/07 13:00
S109	53	second (optical\$2 clear adhes\$2 or OCA) same (display or screen or LCD)	US-PGPUB; USPAT; USOCR; FPRS; EPO; JPO; DERWENT; IBM_TDB	ADJ	ON	2014/11/07 15:38
S110	496	(LCD or display) near4 (dielectric or	US-PGPUB;	ADJ	ON	2014/11/10

PETITIONERS

Exhibit 1003, Page 39

		cover) and (OCA or clear adhes\$3)	USPAT; USOCR; FPRS; EPO; JPO; DERWENT; IBM_TDB			12:19
--	--	------------------------------------	---	--	--	-------

**EAST Search History (Interference)**

Ref #	Hits	Search Query	DBs	Default Operator	Plurals	Time Stamp
L7	1734	((H01H13/702 OR H01H2239/006).CPC. )	US-PGPUB; USPAT; UPAD	ADJ	ON	2014/11/13 18:05
L8	267	first (surface or face) near substrate and electrode and adhes\$3 and second (surface or face) near substrate and micrometer	US-PGPUB; USPAT; UPAD	ADJ	ON	2014/11/13 18:05
L9	458	(LCD or display) near4 (dielectric or cover) and (OCA or clear adhes\$3)	US-PGPUB; USPAT; UPAD	ADJ	ON	2014/11/13 18:06
L10	452	"345".clas. and (optical\$2 clear adhes\$2 or OCA)	US-PGPUB; USPAT; UPAD	ADJ	ON	2014/11/13 18:06
L11	140	(200/181.ccls. or 345/172-174.ccls.) and (optical or clear or transparent) near4 substrate same (first and second) surface	US-PGPUB; USPAT; UPAD	ADJ	ON	2014/11/13 18:08

**11/13/2014 6:09:45 PM****C:\Users\asaeeed\Documents\EAST\Workspaces\13312405.wsp**

PTO/SB/08  <b>INFORMATION DISCLOSURE STATEMENT BY APPLICANT</b>	<b>Application Number:</b> 13/312,405	<b>First Named Inventor:</b> David Brent Guard	
	<b>Attorney Docket No:</b> 080900.1371	<b>Art Unit:</b> 2833 <b>Confirmation #</b> 6025	<b>Filing Date:</b> December 6, 2011

**ISSUED U.S. PATENTS AND PUBLISHED U.S. APPLICATIONS**

	<b>DOCUMENT NUMBER</b>	<b>PUBLICATION OR ISSUE DATE</b>	<b>FIRST NAMED INVENTOR</b>
A			
B			
C			
D			
E			
F			
G			

**NON-PATENT LITERATURE (NPL)**

	<b>DOCUMENT (Including Author, Title, Source, and Pertinent Pages)</b>	<b>DATE</b>
H	Guard et al., USSN 13/347,859, Notice of Appeal (Attorney's Docket 080900.1424).	01/31/2014
I	Guard et al., USSN 13/347,859, Applicant-Initiated Interview Summary (Attorney's Docket 080900.1424).	02/06/2014
J	Guard et al., USSN 13/347,859, Applicant Summary of Interview with Examiner (Attorney's Docket 080900.1424).	03/10/2014
R		

**ISSUED U.S. PATENTS AND PUBLISHED U.S. APPLICATIONS**

	<b>DOCUMENT NUMBER</b>	<b>PUBLICATION OR ISSUE DATE</b>	<b>FIRST NAMED INVENTOR</b>
A			
B			
C			
D			
E			
F			
G			
H			
I			

<b>EXAMINER</b>  /Ahmed Saeed/	<b>DATE CONSIDERED</b>  11/13/2014
--------------------------------------	--

EXAMINER: Initial if citation considered, whether or not citation is in conformance with MPEP § 609. Draw line through citation if not in conformance and not considered. Include copy of this form with next communication to the applicant.

U.S. PATENT AND TRADEMARK OFFICE

Doc code: IDS

Doc description: Information Disclosure Statement (IDS) Filed

Under the Paperwork Reduction Act of 1995, no persons are required to respond to a collection of information unless it contains a valid OMB control number.

PTO/SB/08a (07-09)

Approved for use through 07/31/2012. OMB 0651-0031

U.S. Patent and Trademark Office; U.S. DEPARTMENT OF COMMERCE

<b>INFORMATION DISCLOSURE STATEMENT BY APPLICANT</b> ( Not for submission under 37 CFR 1.99)	Application Number		13312405
	Filing Date		2011-12-06
	First Named Inventor	David B. Guard	
	Art Unit	2833	
	Examiner Name	Ahmed M. Saeed	
	Attorney Docket Number	080900.1371	

**U.S.PATENTS**

Examiner Initial*	Cite No	Patent Number	Kind Code <sup>1</sup>	Issue Date	Name of Patentee or Applicant of cited Document	Pages, Columns, Lines where Relevant Passages or Relevant Figures Appear
	1	7864503		2011-01-14	Yu-Huel Chang	
	2	8217902		2012-07-10	Ching-Yang Chang	
	3	8355006		2013-01-15	PARK ET AL.	
	4	8456444		2013-06-04	Ishizaki et al.	
	5	8797285		2014-08-05	Guard et al.	
	6	8723824		2014-05-13	Scott A. Myers	

If you wish to add additional U.S. Patent citation information please click the Add button.

**U.S.PATENT APPLICATION PUBLICATIONS**

Examiner Initial*	Cite No	Publication Number	Kind Code <sup>1</sup>	Publication Date	Name of Patentee or Applicant of cited Document	Pages, Columns, Lines where Relevant Passages or Relevant Figures Appear
-------------------	---------	--------------------	------------------------	------------------	---	--

**INFORMATION DISCLOSURE  
STATEMENT BY APPLICANT**  
( Not for submission under 37 CFR 1.99)

Application Number	13312405
Filing Date	2011-12-06
First Named Inventor	David B. Guard
Art Unit	2833
Examiner Name	Ahmed M. Saeed
Attorney Docket Number	080900.1371

1	20080309635	2008-12-18	Mitsumi Matsuo
---	-------------	------------	----------------

If you wish to add additional U.S. Published Application citation information please click the Add button.

**FOREIGN PATENT DOCUMENTS**

Examiner Initial*	Cite No	Foreign Document Number <sup>3</sup>	Country Code <sup>2</sup> i	Kind Code <sup>4</sup>	Publication Date	Name of Patentee or Applicant of cited Document	Pages, Columns, Lines where Relevant Passages or Relevant Figures Appear	T <sup>5</sup>
	1							<input type="checkbox"/>

If you wish to add additional Foreign Patent Document citation information please click the Add button

**NON-PATENT LITERATURE DOCUMENTS**

Examiner Initials*	Cite No	Include name of the author (in CAPITAL LETTERS), title of the article (when appropriate), title of the item (book, magazine, journal, serial, symposium, catalog, etc), date, pages(s), volume-issue number(s), publisher, city and/or country where published.	T <sup>5</sup>
	1	Guard et al., USSN 13/312,405 Notice of Allowance dated March 27, 2014 (Atty Docket 080900.1208).	<input type="checkbox"/>
	2	Guard et al., USSN 13/312,405 Issue Notification dated July 16, 2014 (Atty Docket 080900.1208).	<input type="checkbox"/>
	3	Guard et al., USSN 13/331,022 Final Office Action dated April 15, 2014 (Atty Docket 080900.1370).	<input type="checkbox"/>
	4	Guard et al., USSN 13/331,022 Request for Continued Examination dated July 15, 2014 (Atty Docket 080900.1370).	<input type="checkbox"/>
	5	Guard et al., USSN 13/347,859 Appeal Brief dated March 28, 2014 (Atty Docket 080900.1424).	<input type="checkbox"/>

**INFORMATION DISCLOSURE  
STATEMENT BY APPLICANT**  
( Not for submission under 37 CFR 1.99)

Application Number		13312405
Filing Date		2011-12-06
First Named Inventor	David B. Guard	
Art Unit	2833	
Examiner Name	Ahmed M. Saeed	
Attorney Docket Number	080900.1371	

6	Guard et al., USSN 13/347,859 Examiner's Answer dated July 17, 2014 (Atty Docket 080900.1424).	<input type="checkbox"/>
7	Guard et al., USSN 13/413,306 Final Office Action dated April 11, 2014 (Atty Docket 080900.1425).	<input type="checkbox"/>
8	Guard et al., USSN 13/413,306 Request for Continued Examination dated July 11, 2014 (Atty Docket 080900.1425).	<input type="checkbox"/>

If you wish to add additional non-patent literature document citation information please click the Add button

**EXAMINER SIGNATURE**

Examiner Signature		Date Considered	
--------------------	--	-----------------	--

\*EXAMINER: Initial if reference considered, whether or not citation is in conformance with MPEP 609. Draw line through a citation if not in conformance and not considered. Include copy of this form with next communication to applicant.

<sup>1</sup> See Kind Codes of USPTO Patent Documents at [www.USPTO.GOV](http://www.USPTO.GOV) or MPEP 901.04. <sup>2</sup> Enter office that issued the document, by the two-letter code (WIPO Standard ST.3). <sup>3</sup> For Japanese patent documents, the indication of the year of the reign of the Emperor must precede the serial number of the patent document. <sup>4</sup> Kind of document by the appropriate symbols as indicated on the document under WIPO Standard ST.16 if possible. <sup>5</sup> Applicant is to place a check mark here if English language translation is attached.



## Electronic Patent Application Fee Transmittal

<b>Application Number:</b>	13312405
<b>Filing Date:</b>	06-Dec-2011
<b>Title of Invention:</b>	Two-Layer Sensor Stack
<b>First Named Inventor/Applicant Name:</b>	David Brent Guard
<b>Filer:</b>	Chad D Terrell/Esmarie Garland
<b>Attorney Docket Number:</b>	080900.1371

Filed as Large Entity

### Utility under 35 USC 111(a) Filing Fees

Description	Fee Code	Quantity	Amount	Sub-Total in USD(\$)
<b>Basic Filing:</b>				
<b>Pages:</b>				
<b>Claims:</b>				
<b>Miscellaneous-Filing:</b>				
<b>Petition:</b>				
<b>Patent-Appeals-and-Interference:</b>				
<b>Post-Allowance-and-Post-Issuance:</b>				
<b>Extension-of-Time:</b>				
Extension - 3 months with \$0 paid	1253	1	1400	PETITIONERS 1400

Description	Fee Code	Quantity	Amount	Sub-Total in USD(\$)
<b>Miscellaneous:</b>				
Request for Continued Examination	1801	1	1200	1200
<b>Total in USD (\$)</b>				<b>2600</b>

## Electronic Acknowledgement Receipt

<b>EFS ID:</b>	20065071
<b>Application Number:</b>	13312405
<b>International Application Number:</b>	
<b>Confirmation Number:</b>	6025
<b>Title of Invention:</b>	Two-Layer Sensor Stack
<b>First Named Inventor/Applicant Name:</b>	David Brent Guard
<b>Customer Number:</b>	12323
<b>Filer:</b>	Chad D Terrell/Esmarie Garland
<b>Filer Authorized By:</b>	Chad D Terrell
<b>Attorney Docket Number:</b>	080900.1371
<b>Receipt Date:</b>	05-SEP-2014
<b>Filing Date:</b>	06-DEC-2011
<b>Time Stamp:</b>	18:32:48
<b>Application Type:</b>	Utility under 35 USC 111(a)

### Payment information:

Submitted with Payment	yes
Payment Type	Deposit Account
Payment was successfully received in RAM	\$2600
RAM confirmation Number	5718
Deposit Account	020384
Authorized User	

The Director of the USPTO is hereby authorized to charge indicated fees and credit any overpayment as follows:

Charge any Additional Fees required under 37 C.F.R. Section 1.16 (National application filing, search, and examination fees)

Charge any Additional Fees required under 37 C.F.R. Section 1.17 (Patent application and reexamination procedure fees)

PETITIONERS

Charge any Additional Fees required under 37 C.F.R. Section 1.19 (Document supply fees)

Charge any Additional Fees required under 37 C.F.R. Section 1.20 (Post Issuance fees)

Charge any Additional Fees required under 37 C.F.R. Section 1.21 (Miscellaneous fees and charges)

### File Listing:

Document Number	Document Description	File Name	File Size(Bytes)/ Message Digest	Multi Part /.zip	Pages (if appl.)
1	Request for Continued Examination (RCE)	0809001371RCETransmittal.PDF	102817 9d54e6df76265ef3417d691e661a9a8c60b b7f67	no	1

### Warnings:

This is not a USPTO supplied RCE SB30 form.

The page size in the PDF is too large. The pages should be 8.5 x 11 or A4. If this PDF is submitted, the pages will be resized upon entry into the Image File Wrapper and may affect subsequent processing

### Information:

2		0809001371Response.PDF	485742 41ca6ea6614366da2d00795be7255b04b2 e13d8f	yes	10
---	--	------------------------	--	-----	----

#### Multipart Description/PDF files in .zip description

Document Description	Start	End
Amendment Submitted/Entered with Filing of CPA/RCE	1	1
Claims	2	4
Applicant Arguments/Remarks Made in an Amendment	5	10

### Warnings:

The page size in the PDF is too large. The pages should be 8.5 x 11 or A4. If this PDF is submitted, the pages will be resized upon entry into the Image File Wrapper and may affect subsequent processing

### Information:

3		0809001371IDS.PDF	221124 0c3215f79584e1c94c4fa472ad02bfb23deb b08b	yes	5
---	--	-------------------	--	-----	---

#### Multipart Description/PDF files in .zip description

Document Description	Start	End
Transmittal Letter	1	2
Information Disclosure Statement (IDS) Form (SB08)	3	5

### Warnings:

The page size in the PDF is too large. The pages should be 8.5 x 11 or A4. If this PDF is submitted, the pages will be resized upon entry into the Image File Wrapper and may affect subsequent processing

### Information:

4	Other Reference-Patent/App/Search documents	Atmel1208NoticeOfAllow27March14.pdf	526110 7376e927aa01407587f542e877af61cdc4aa4c33	no	10
<b>Warnings:</b>					
<b>Information:</b>					
5	Other Reference-Patent/App/Search documents	Atmel1208IssueNotif16July14.pdf	54509 f3cc074ca0de1e7d2e88bdd258a1bfc5e11d913	no	1
<b>Warnings:</b>					
<b>Information:</b>					
6	Other Reference-Patent/App/Search documents	Atmel1370FinalOA15April14.pdf	483699 7518ffc7cad1aa4ee5a06ba5162ea257c56fb45c	no	15
<b>Warnings:</b>					
<b>Information:</b>					
7	Other Reference-Patent/App/Search documents	Atmel1370RCE15July14.pdf	584814 533d32e412fef6924c290b2f5303bf34d09caafb	no	12
<b>Warnings:</b>					
<b>Information:</b>					
8	Other Reference-Patent/App/Search documents	Atmel1424AppBrief28March14.pdf	1422521 e9910c596cd50981def30ee69479b4b88dfda7cf	no	29
<b>Warnings:</b>					
<b>Information:</b>					
9	Other Reference-Patent/App/Search documents	Atmel1424ExAnsAppBrf17July14.pdf	268792 10f38a6a7d143f8972bb72356dc3f3cb18608b54	no	9
<b>Warnings:</b>					
<b>Information:</b>					
10	Other Reference-Patent/App/Search documents	Atmel1425FinalOA11April14.pdf	504674 b86e7eec10f5c0debed993bdba81b304048d4a75	no	17
<b>Warnings:</b>					
<b>Information:</b>					
11	Other Reference-Patent/App/Search documents	Atmel1425RCE11July14.pdf	687565 119befdd93f1e2565f73527d321b94f2765168b6	no	14
<b>Warnings:</b>					
<b>Information:</b>					
12	Fee Worksheet (SB06)	fee-info.pdf	31963 687f7c358d16f2701774466b293218e4a0353c1	no	2
<b>Warnings:</b>					
<b>Information:</b>					

**This Acknowledgement Receipt evidences receipt on the noted date by the USPTO of the indicated documents, characterized by the applicant, and including page counts, where applicable. It serves as evidence of receipt similar to a Post Card, as described in MPEP 503.**

**New Applications Under 35 U.S.C. 111**

**If a new application is being filed and the application includes the necessary components for a filing date (see 37 CFR 1.53(b)-(d) and MPEP 506), a Filing Receipt (37 CFR 1.54) will be issued in due course and the date shown on this Acknowledgement Receipt will establish the filing date of the application.**

**National Stage of an International Application under 35 U.S.C. 371**

**If a timely submission to enter the national stage of an international application is compliant with the conditions of 35 U.S.C. 371 and other applicable requirements a Form PCT/DO/EO/903 indicating acceptance of the application as a national stage submission under 35 U.S.C. 371 will be issued in addition to the Filing Receipt, in due course.**

**New International Application Filed with the USPTO as a Receiving Office**

**If a new international application is being filed and the international application includes the necessary components for an international filing date (see PCT Article 11 and MPEP 1810), a Notification of the International Application Number and of the International Filing Date (Form PCT/RO/105) will be issued in due course, subject to prescriptions concerning national security, and the date shown on this Acknowledgement Receipt will establish the international filing date of the application.**

Under the Paperwork Reduction Act of 1995, no persons are required to respond to a collection of information unless it contains a valid OMB control number.

**Request  
 for  
 Continued Examination (RCE)  
 Transmittal**

Address to:  
 Mail Stop RCE  
 Commissioner for Patents  
 P.O. Box 1450  
 Alexandria, VA 22313-1450

Application Number	13/312,405
Filing Date	December 6, 2011
First Named Inventor	David B. Guard
Art Unit	2833; confirmation #6025
Examiner Name	Ahmed M. Saeed
Attorney Docket Number	080900.1371

**This is a Request for Continued Examination (RCE) under 37 CFR 1.114 of the above-identified application.**  
 Request for Continued Examination (RCE) practice under 37 CFR 1.114 does not apply to any utility or plant application filed prior to June 8, 1995, or to any design application. See Instruction Sheet for RCEs (not to be submitted to the USPTO) on page 2.

- Submission required under 37 CFR 1.114** Note: If the RCE is proper, any previously filed unentered amendments and amendments enclosed with the RCE will be entered in the order in which they were filed unless applicant instructs otherwise. If applicant does not wish to have any previously filed unentered amendment(s) entered, applicant must request non-entry of such amendment(s).

  - Previously submitted. If a final Office action is outstanding, any amendments filed after the final Office action may be considered as a submission even if this box is not checked.
    - Consider the arguments in the Appeal Brief or Reply Brief previously filed on \_\_\_\_\_
    - Other \_\_\_\_\_
  - Enclosed
    - Amendment/Reply
    - Affidavit(s)/ Declaration(s)
    - Information Disclosure Statement (IDS)
    - Other \_\_\_\_\_
- Miscellaneous**

  - Suspension of action on the above-identified application is requested under 37 CFR 1.103(c) for a period of \_\_\_\_\_ months. (Period of suspension shall not exceed 3 months; Fee under 37 CFR 1.17(i) required)
  - Other \_\_\_\_\_
- Fees** The RCE fee under 37 CFR 1.17(e) is required by 37 CFR 1.114 when the RCE is filed. The Director is hereby authorized to charge the following fees, any underpayment of fees, or credit any overpayments, to Deposit Account No. 02-0384.

  - RCE fee required under 37 CFR 1.17(e)
  - Extension of time fee (37 CFR 1.136 and 1.17)
  - Other \_\_\_\_\_
  - Check in the amount of \$ \_\_\_\_\_ enclosed
  - Payment by credit card (Form PTO-2038 enclosed)

**WARNING: Information on this form may become public. Credit card information should not be included on this form. Provide credit card information and authorization on PTO-2038.**

**SIGNATURE OF APPLICANT, ATTORNEY, OR AGENT REQUIRED**

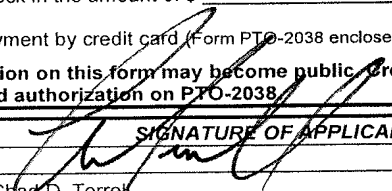
Signature		Date	September 5, 2014
Name (Print/Type)	Chad D. Terrey	Registration No.	52,279

**CERTIFICATE OF MAILING OR TRANSMISSION**

I hereby certify that this correspondence is being deposited with the United States Postal Service with sufficient postage as first class mail in an envelope addressed to: Mail Stop RCE, Commissioner for Patents, P. O. Box 1450, Alexandria, VA 22313-1450 or facsimile transmitted to the U.S. Patent and Trademark Office on the date shown below.

Signature		Date	
Name (Print/Type)			

This collection of information is required by 37 CFR 1.114. The information is required to obtain or retain a benefit by the public which is to file (and by the USPTO to process) an application. Confidentiality is governed by 35 U.S.C. 122 and 37 CFR 1.11 and 1.14. This collection is estimated to take 12 minutes to complete, including gathering, preparing, and submitting the completed application form to the USPTO. Time will vary depending upon the individual case. Any comments on the amount of time you require to complete this form and/or suggestions for reducing this burden, should be sent to the Chief Information Officer, U.S. Patent and Trademark Office, U.S. Department of Commerce, P.O. Box 1450, Alexandria, VA 22313-1450. DO NOT SEND FEES OR COMPLETED FORMS TO THIS ADDRESS. SEND TO: Mail Stop RCE, Commissioner for Patents, P.O. Box 1450, Alexandria, VA 22313-1450.

If you need assistance in completing the form, call 1-800-PTO-9199 and select option 2.

**IN THE UNITED STATES PATENT AND TRADEMARK OFFICE**

First Named Inventor: Brent David Guard  
Serial No.: 13/312,405  
Filing Date: December 11, 2011  
Art Unit: 2833  
Confirmation No.: 6025  
Examiner: Ahmed M Saeed  
Title: *Two-Layer Sensor Stack*

Commissioner for Patents  
P.O. Box 1450  
Alexandria, VA 22313-1450

**Response under 37 C.F.R. § 1.114**

In response to the Final Office Action dated March 6, 2014, Applicant respectfully request the Examiner to reconsider the rejections of the claims in view of the following amendments and remarks, filed with a Request for Continued Examination (RCE). Please amend the Application as follows.



**In the Claims:**

1. (Currently amended) An apparatus comprising:  
a first optically clear adhesive (OCA) layer between a first cover sheet and a substrate;

the substrate, with drive or sense electrodes of a touch sensor disposed on a first surface and a second surface of the substrate, the first surface being opposite the second surface, the drive or sense electrodes being made of a conductive mesh conductive material comprising metal; and

a display separated from the second surface of the substrate by a second OCA and a second cover sheet such that at least a portion of the second cover sheet is positioned between the second surface of the substrate and the display.

2-3. (Canceled)

4. (Original) The apparatus of Claim 1, wherein the conductive material is copper, silver, gold, aluminum, or tin.

5. (Original) The apparatus of Claim 1, wherein the conductive mesh comprises a plurality of mesh segments, each of the mesh segments having a width of approximately 10  $\mu\text{m}$ .

6. (Original) The apparatus of Claim 5, wherein approximately 5% of an active area of the touch sensor is covered by the one or more mesh segments.

7. (Original) The apparatus of Claim 5, wherein each of the mesh segments is substantially sinusoidal.

8. (Original) The apparatus of Claim 1, wherein the conductive meshes have an optical transmissivity of approximately 90%.

9. (Original) The apparatus of Claim 1, wherein the sense electrodes being disposed on the first surface of the substrate and the drive electrodes being disposed on the second surface of the substrate.

10. (Currently amended) A device comprising:

a first cover sheet;

a first optically clear adhesive layer (OCA) between the first cover sheet and a substrate;

the substrate, with drive or sense electrodes of a touch sensor disposed on a first surface and a second surface of the substrate, the first surface being opposite the second surface, the drive or sense electrodes being made of a conductive mesh conductive material comprising metal;

a display separated from the second surface of the substrate by a second OCA and a second cover sheet such that at least a portion of the second cover sheet is positioned between the second surface of the substrate and the display; and

one or more computer-readable non-transitory storage media embodying logic that is configured when executed to control the touch sensor.

11-12. (Canceled)

13. (Original) The device of Claim 10, wherein the conductive material is copper, silver, gold, aluminum, or tin.

14. (Original) The device of Claim 10, wherein the conductive mesh comprises a plurality of mesh segments, each of the mesh segments having a width of approximately 10  $\mu\text{m}$ .

15. (Original) The device of Claim 14, wherein approximately 5% of an active area of the touch sensor is covered by the mesh segments.

16. (Original) The device of Claim 14, wherein each of the mesh segments is substantially sinusoidal.

17. (Original) The device of Claim 10, wherein the conductive meshes have an optical transmissivity of approximately 90%.

18. (Original) The device of Claim 10, wherein the sense electrodes being disposed on the first surface of the substrate and the drive electrodes being disposed on the second surface of the substrate.

19. (Currently amended) An apparatus comprising:

a first optically clear adhesive (OCA) layer between a first cover sheet and a substrate;

the substrate, with sense electrodes of a touch sensor disposed on a first surface and drive electrodes of the touch sensor disposed on a second surface of the substrate, the first surface being opposite the second surface, the drive and sense electrodes being made of a conductive mesh of conductive material comprising metal; and

a display separated from the second surface of the substrate by a second OCA and a second cover sheet such that at least a portion of the second cover sheet is positioned between the second surface of the substrate and the display.

20. (Canceled)

**Remarks**

This Application has been reviewed carefully in light of the Final Office Action dated March 6, 2014. Applicant appreciates the Examiner's consideration of the Application. Although Applicant believes all claims are allowable without amendment, to advance prosecution Applicant has made clarifying amendments to Claims 1, 10, and 19. At least certain of these amendments are not considered narrowing, and none are considered necessary for patentability. Additionally, Applicant does not admit that these amendments are made in response to or necessitated by any cited reference or combination of cited references. Applicant respectfully requests reconsideration and allowance of all pending claims.

**Request for Interview**

If the Examiner intends to issue a new Action in response to this submission, in the interest of compact and efficient prosecution, Applicant respectfully requests that the Examiner contact Applicant's attorney prior to issuing the new Action to discuss a possible resolution to any outstanding issues.

**The Claims are Allowable over the Proposed *Hotelling-Bick* Combination**

The Office Action rejects Claims 1, 4, 9-10, 13, and 18-19 under pre-AIA 35 U.S.C. § 103(a) as allegedly being unpatentable over U.S. Patent Application Publication No. 2008/0158183 ("*Hotelling*") in view of U.S. Patent No. 6,924,789 ("*Bick*"). Applicant respectfully traverses these rejections and discusses independent Claim 1 as an example.

At a minimum, the cited portions of the proposed *Hotelling-Bick* combination do not disclose, teach, or suggest "a display separated from the second surface of the substrate by a second OCA and a second cover sheet," as recited in Claim 1 even prior to the present amendments, let alone "a display separated from the second surface of the substrate by a second OCA and a second cover sheet such that at least a portion of the second cover sheet is positioned between the second surface of the substrate and the display," as recited in amended Claim 1. The Office Action states that "*Hotelling* does not teach the display being separated by a second cover." *Office Action* at 2. However, the Office Action alleges that "*Bick* teaches a display 4 separated from the second surface of the substrate 20 by dielectric

layer 27 (Bick fig 3, col. 2, lines 38-50).” *Id.* Even assuming for the sake of argument only that first sensing plate 20, dielectric layer 27, and display 4 could be equated to the claimed “substrate,” “second cover sheet,” and “display,” respectively, which Applicant does not concede, Applicant respectfully submits that *Bick* still fails to make up for at least the acknowledged deficiencies of *Hotelling*.

Figure 1 of *Bick* shows a “mobile telephone handset 1” that includes a “liquid crystal display (LCD) panel 4” and a “keypad 7.” As shown below, LCD panel 4 occupies a different area of mobile handset 1 than keypad 7:

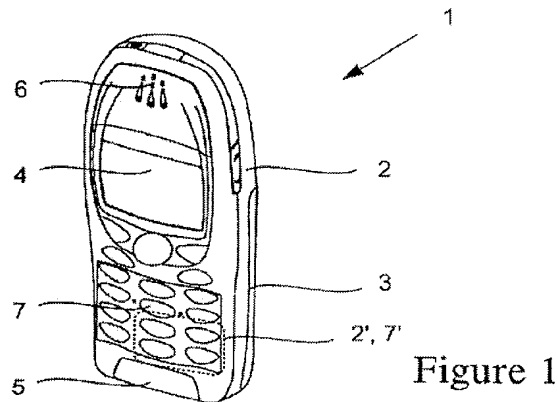

*Bick* at Fig. 1. Figure 3 of *Bick* illustrates an exploded view of keypad 7, and particularly cutaway portion keypad 7'. See *Bick* at Fig. 3. Figure 3 illustrates the cited substrate 20 and dielectric layer 27. Figure 3 does not illustrate display 4, and certainly does not illustrate that display 4 is separated from a second surface of a substrate (first sensing plate 20, according to the Office Action's apparent equations) by a second OCA and a second cover sheet (dielectric layer 27, according to the Office Action's apparent equations), let alone such that at least a portion of a second cover sheet (dielectric layer 27, according to the Office Action's apparent equations) is positioned between a second surface of a substrate (first sensing plate 20, according to the Office Action's apparent equations) and display 4. In fact, Figure 1 shows that display 4 is in a different area of mobile telephone handset 1 than keypad 7 (a portion of which is detailed in cited Figure 3), which explains why display 4 would not be included in Figure 3.

Thus, even assuming for the sake of argument only that first sensing plate 20, dielectric layer 27, and display 4 could be equated to the claimed “substrate,” “second cover sheet,” and “display,” respectively, which Applicant does not concede, *Bick* still fails to disclose, teach, or suggest “a display separated from the second surface of the substrate by a second OCA and a second cover sheet,” as recited in Claim 1 even before the present amendments, let alone “a display separated from the second surface of the substrate by a second OCA and a second cover sheet such that at least a portion of the second cover sheet is positioned between the second surface of the substrate and the display,” as recited in amended Claim 1.

Furthermore, Applicant also respectfully submits that the proposed *Hotelling-Bick* combination does not disclose, teach, or suggest at least these features of Claim 1. As discussed above, neither cited reference actually discloses “a display separated from the second surface of the substrate by a second OCA and a second cover sheet,” as recited in Claim 1 even before the present amendments, let alone “a display separated from the second surface of the substrate by a second OCA and a second cover sheet such that at least a portion of the second cover sheet is positioned between the second surface of the substrate and the display,” as recited in amended Claim 1. Thus, even assuming for the sake of argument only that dielectric layer 27 of *Bick* could be equated to the claimed second cover sheet and further that it would have been obvious to modify *Hotelling* to include dielectric layer 27 of *Bick* somewhere in the device of *Hotelling* (neither of which Applicant concedes), that proposed combination still would not disclose, teach, or suggest at least the above-identified features of Claim 1.

Therefore, the proposed *Hotelling-Bick* combination does not disclose, teach, or suggest each and every feature of Claim 1, both before and after the amendments to Claim 1.

Additionally, Applicant does not admit that the proposed *Hotelling-Bick* combination is possible or that the Office Action provides an adequate reason for combining or modifying these references in the proposed manner. To avoid burdening the record and in view of the allowability of independent Claim 1 for at least the above-discussed reasons, Applicant does

not discuss this issue in this submission. However, Applicant reserves the right to discuss this issue in a future submission, if appropriate.

For at least these reasons, Applicant respectfully requests reconsideration and allowance of independent Claim 1 and its dependent claims. For at least certain analogous reasons, Applicant respectfully requests reconsideration and allowance of independent Claims 10 and 19 and their dependent claims.

**Claims 5-8 and 14-17 are Allowable over the Proposed *Hotelling-Bick-Frey* Combination**

The Office Action rejects Claims 5-8 and 14-17 under 35 U.S.C. § 103(a) as being unpatentable over *Hotelling* and *Bick* and further in view of U.S. Patent Application Publication No. 2009/0219257 ("*Frey*"). Applicant respectfully traverses these rejections. Claims 5-8 and 14-17 depend from independent Claims 1 and 10, respectively, shown above to be allowable over the proposed *Hotelling-Bick* combination. The cited portions of *Frey* do not appear to make up for at least the above-discussed deficiencies of the proposed *Hotelling-Bick* combination. Thus, dependent Claims 5-8 and 14-17 are allowable at least because they depend from allowable independent claims. Furthermore, dependent Claims 5-8 and 14-17 recited further patentable features. To avoid burdening the record and in view of the allowability of the independent claims, Applicant does not discuss these features in this submission. Applicant, however, reserves the right to discuss these features in a future submission, if appropriate. Moreover, Applicant does not admit that the proposed *Hotelling-Bick-Frey* combination is possible or that the Office Action provides an adequate reason for combining or modifying the references in the manner proposed in the Office Action. For at least these reasons, Applicant respectfully requests reconsideration and allowance of Claims 5-8 and 14-17.

**Request for Evidentiary Support**

Should a rejection based on any of the above asserted rejections be maintained, Applicant respectfully requests appropriate evidentiary support. For example, if the Examiner is relying upon alleged "common knowledge," alleged "well known" principles, Official Notice, or other information within the Examiner's personal knowledge to establish

the rejection, Applicant respectfully requests that the Examiner cite a reference as documentary evidence in support of this position or provide an affidavit. *See* M.P.E.P. § 2144.03 and 37 C.F.R. § 1.104(d)(2).

**No Waiver**

Applicant's arguments and amendments are made without prejudice or disclaimer. Additionally, Applicant has merely discussed example distinctions from the cited references. Other distinctions may exist, and Applicant reserves the right to discuss these additional distinctions in a later submission, if appropriate. By not responding to additional statements made in the Office Action, Applicant does not acquiesce to the additional statements.



**Conclusion**

Applicant has made an earnest attempt to place this Application in condition for allowance. For at least the foregoing reasons, Applicant respectfully requests full allowance of all pending claims.

If the Examiner believes a telephone conference would advance prosecution of this Application in any way, the Examiner is invited to contact Chad D. Terrell, Attorney for Applicant, at (214) 953-6813, at the Examiner's convenience.

The Commissioner is authorized to charge the appropriate fees for a first RCE and a three-month extension of time to Deposit Account No. 02-0384 of Baker Botts L.L.P. Although Applicant believes no other fee is due, the Commissioner is authorized to charge any necessary additional fees and credit any overpayments to Deposit Account No. 02-0384 of Baker Botts L.L.P.

Respectfully submitted,

BAKER BOTTS L.L.P.  
Attorneys for Applicants

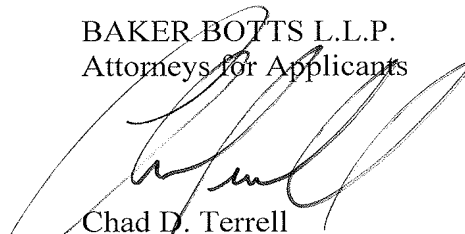

Chad D. Terrell  
Reg. No. 52,279

Date: September 5, 2014

Correspondence Address:

Customer No. **12323**

IN THE UNITED STATES PATENT AND TRADEMARK OFFICE

First Named Inventor: David B. Guard  
Application No.: 13/312,405  
Filing Date: December 6, 2011  
Art Unit: 2833  
Confirmation No.: 6025  
Examiner: Ahmed M. Saeed  
Title: *Two-Layer Sensor Sack*

Commissioner of Patents  
PO Box 1450  
Alexandria, VA 22313-1450

Dear Sir:

**Supplemental Information Disclosure Statement (IDS)**

Applicant respectfully requests, pursuant to 37 C.F.R. §§1.56, 1.97, and 1.98, that the documents listed on the attached PTO/SB/08 form be considered and cited in the examination of the above-identified patent application. Applicant makes no representation that a search has been made, that these documents are material to patentability of the present application, or that these documents qualify as prior art. *See* 37 C.F.R. §§ 1.97(g) and (h).

Copies of U.S. patents and U.S. patent application publications have not been provided. To the extent applicable, references other than U.S. patents and U.S. patent application publications are enclosed for the convenience of the Examiner.

This IDS is being submitted concurrently with the filing of a Request for Continued Examination, and thus before the mailing of a first Office Action after the filing of an RCE. Therefore, Applicant believes no fee is due. *See* 37 C.F.R. § 1.97(b). However, the Commissioner is authorized to charge any necessary fees and credit any overpayments to Deposit Account No. 02-0384 of Baker Botts L.L.P.

Respectfully submitted,

BAKER BOTTS L.L.P.  
Attorneys for Applicant

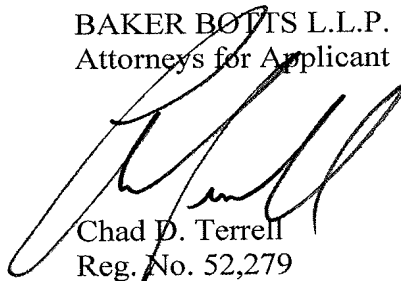

Chad D. Terrell  
Reg. No. 52,279

Date: 9/5/14

Correspondence Address:  
Customer No. **12323**

Under the Paperwork Reduction Act of 1995, no persons are required to respond to a collection of information unless it displays a valid OMB control number.

<b>PATENT APPLICATION FEE DETERMINATION RECORD</b> Substitute for Form PTO-875	Application or Docket Number <b>13/312,405</b>	Filing Date <b>12/06/2011</b>	<input type="checkbox"/> To be Mailed
---	---	----------------------------------	---------------------------------------

ENTITY:  LARGE  SMALL  MICRO

**APPLICATION AS FILED – PART I**

FOR	NUMBER FILED	NUMBER EXTRA	RATE (\$)	FEE (\$)
<input type="checkbox"/> BASIC FEE <small>(37 CFR 1.16(a), (b), or (c))</small>	N/A	N/A	N/A	
<input type="checkbox"/> SEARCH FEE <small>(37 CFR 1.16(k), (l), or (m))</small>	N/A	N/A	N/A	
<input type="checkbox"/> EXAMINATION FEE <small>(37 CFR 1.16(o), (p), or (q))</small>	N/A	N/A	N/A	
TOTAL CLAIMS <small>(37 CFR 1.16(i))</small>	minus 20 =	*	X \$ =	
INDEPENDENT CLAIMS <small>(37 CFR 1.16(h))</small>	minus 3 =	*	X \$ =	
<input type="checkbox"/> APPLICATION SIZE FEE <small>(37 CFR 1.16(s))</small>	If the specification and drawings exceed 100 sheets of paper, the application size fee due is \$310 (\$155 for small entity) for each additional 50 sheets or fraction thereof. See 35 U.S.C. 41(a)(1)(G) and 37 CFR 1.16(s).			
<input type="checkbox"/> MULTIPLE DEPENDENT CLAIM PRESENT <small>(37 CFR 1.16(j))</small>				
* If the difference in column 1 is less than zero, enter "0" in column 2.			TOTAL	

**APPLICATION AS AMENDED – PART II**

	(Column 1)	(Column 2)	(Column 3)	PRESENT EXTRA	RATE (\$)	ADDITIONAL FEE (\$)
<b>AMENDMENT</b>	<b>09/05/2014</b>	CLAIMS REMAINING AFTER AMENDMENT	HIGHEST NUMBER PREVIOUSLY PAID FOR			
	Total <small>(37 CFR 1.16(i))</small>	* 15	Minus	** 20	= 0	X \$80 = 0
	Independent <small>(37 CFR 1.16(h))</small>	* 3	Minus	***3	= 0	X \$420 = 0
	<input type="checkbox"/> Application Size Fee <small>(37 CFR 1.16(s))</small>					
<input type="checkbox"/> FIRST PRESENTATION OF MULTIPLE DEPENDENT CLAIM <small>(37 CFR 1.16(j))</small>						
					TOTAL ADD'L FEE	<b>0</b>

	(Column 1)	(Column 2)	(Column 3)	PRESENT EXTRA	RATE (\$)	ADDITIONAL FEE (\$)
<b>AMENDMENT</b>		CLAIMS REMAINING AFTER AMENDMENT	HIGHEST NUMBER PREVIOUSLY PAID FOR			
	Total <small>(37 CFR 1.16(i))</small>	*	Minus	**	=	X \$ =
	Independent <small>(37 CFR 1.16(h))</small>	*	Minus	***	=	X \$ =
	<input type="checkbox"/> Application Size Fee <small>(37 CFR 1.16(s))</small>					
<input type="checkbox"/> FIRST PRESENTATION OF MULTIPLE DEPENDENT CLAIM <small>(37 CFR 1.16(j))</small>						
					TOTAL ADD'L FEE	

\* If the entry in column 1 is less than the entry in column 2, write "0" in column 3.  
 \*\* If the "Highest Number Previously Paid For" IN THIS SPACE is less than 20, enter "20".  
 \*\*\* If the "Highest Number Previously Paid For" IN THIS SPACE is less than 3, enter "3".

The "Highest Number Previously Paid For" (Total or Independent) is the highest number found in the appropriate box in column 1.

LIE  
/LAJUAN HICKSON/

This collection of information is required by 37 CFR 1.16. The information is required to obtain or retain a benefit by the public which is to file (and by the USPTO to process) an application. Confidentiality is governed by 35 U.S.C. 122 and 37 CFR 1.14. This collection is estimated to take 12 minutes to complete, including gathering, preparing, and submitting the completed application form to the USPTO. Time will vary depending upon the individual case. Any comments on the amount of time you require to complete this form and/or suggestions for reducing this burden, should be sent to the Chief Information Officer, U.S. Patent and Trademark Office, U.S. Department of Commerce, P.O. Box 1450, Alexandria, VA 22313-1450. DO NOT SEND FEES OR COMPLETED FORMS TO THIS ADDRESS. **SEND TO: Commissioner for Patents, P.O. Box 1450, Alexandria, VA 22313-1450.**

If you need assistance in completing the form, call 1-800-PTO-9199 and select option 2.

PTO/SB/08  <b>INFORMATION DISCLOSURE STATEMENT BY APPLICANT</b>	<b>Application Number:</b> 13/312,405	<b>First Named Inventor:</b> David Brent Guard	
	<b>Attorney Docket No:</b> 080900.1371	<b>Art Unit:</b> 2833 <b>Confirmation #</b> 6025	<b>Filing Date:</b> December 6, 2011

**ISSUED U.S. PATENTS AND PUBLISHED U.S. APPLICATIONS**

	<b>DOCUMENT NUMBER</b>	<b>PUBLICATION OR ISSUE DATE</b>	<b>FIRST NAMED INVENTOR</b>
A			
B			
C			
D			
E			
F			
G			

**NON-PATENT LITERATURE (NPL)**

	<b>DOCUMENT (Including Author, Title, Source, and Pertinent Pages)</b>	<b>DATE</b>
H	Guard et al., USSN 13/347,859, Notice of Appeal (Attorney's Docket 080900.1424).	01/31/2014
I	Guard et al., USSN 13/347,859, Applicant-Initiated Interview Summary (Attorney's Docket 080900.1424).	02/06/2014
J	Guard et al., USSN 13/347,859, Applicant Summary of Interview with Examiner (Attorney's Docket 080900.1424).	03/10/2014
R		

**ISSUED U.S. PATENTS AND PUBLISHED U.S. APPLICATIONS**

	<b>DOCUMENT NUMBER</b>	<b>PUBLICATION OR ISSUE DATE</b>	<b>FIRST NAMED INVENTOR</b>
A			
B			
C			
D			
E			
F			
G			
H			
I			

EXAMINER	DATE CONSIDERED
EXAMINER: Initial if citation considered, whether or not citation is in conformance with MPEP § 609. Draw line through citation if not in conformance and not considered. Include copy of this form with next communication to the applicant.	

## Electronic Patent Application Fee Transmittal

<b>Application Number:</b>	13312405
<b>Filing Date:</b>	06-Dec-2011
<b>Title of Invention:</b>	Two-Layer Sensor Stack
<b>First Named Inventor/Applicant Name:</b>	David Brent Guard
<b>Filer:</b>	Stanton Aaron Lewis/Esmarie Garland
<b>Attorney Docket Number:</b>	080900.1371

Filed as Large Entity

### Utility under 35 USC 111(a) Filing Fees

Description	Fee Code	Quantity	Amount	Sub-Total in USD(\$)
<b>Basic Filing:</b>				
<b>Pages:</b>				
<b>Claims:</b>				
<b>Miscellaneous-Filing:</b>				
<b>Petition:</b>				
<b>Patent-Appeals-and-Interference:</b>				
<b>Post-Allowance-and-Post-Issuance:</b>				
<b>Extension-of-Time:</b>				

Description	Fee Code	Quantity	Amount	Sub-Total in USD(\$)
<b>Miscellaneous:</b>				
Submission- Information Disclosure Stmt	1806	1	180	180
<b>Total in USD (\$)</b>				<b>180</b>

## Electronic Acknowledgement Receipt

<b>EFS ID:</b>	18528669
<b>Application Number:</b>	13312405
<b>International Application Number:</b>	
<b>Confirmation Number:</b>	6025
<b>Title of Invention:</b>	Two-Layer Sensor Stack
<b>First Named Inventor/Applicant Name:</b>	David Brent Guard
<b>Customer Number:</b>	12323
<b>Filer:</b>	Stanton Aaron Lewis/Esmarie Garland
<b>Filer Authorized By:</b>	Stanton Aaron Lewis
<b>Attorney Docket Number:</b>	080900.1371
<b>Receipt Date:</b>	19-MAR-2014
<b>Filing Date:</b>	06-DEC-2011
<b>Time Stamp:</b>	18:25:11
<b>Application Type:</b>	Utility under 35 USC 111(a)

### Payment information:

Submitted with Payment	yes
Payment Type	Deposit Account
Payment was successfully received in RAM	\$180
RAM confirmation Number	5083
Deposit Account	020384
Authorized User	

The Director of the USPTO is hereby authorized to charge indicated fees and credit any overpayment as follows:

Charge any Additional Fees required under 37 C.F.R. Section 1.16 (National application filing, search, and examination fees)

Charge any Additional Fees required under 37 C.F.R. Section 1.17 (Patent application and reexamination procedure fees)

PETITIONERS



Charge any Additional Fees required under 37 C.F.R. Section 1.19 (Document supply fees)

Charge any Additional Fees required under 37 C.F.R. Section 1.20 (Post Issuance fees)

Charge any Additional Fees required under 37 C.F.R. Section 1.21 (Miscellaneous fees and charges)

**File Listing:**

Document Number	Document Description	File Name	File Size(Bytes)/ Message Digest	Multi Part /.zip	Pages (if appl.)
1		0809001371SuppIDS19Mar14.PDF	134197 5e3756be69f108ba6255f2cca9d04df97607c5fa	yes	3
<b>Multipart Description/PDF files in .zip description</b>					
	<b>Document Description</b>		<b>Start</b>		<b>End</b>
	Transmittal Letter		1		2
	Information Disclosure Statement (IDS) Form (SB08)		3		3
<b>Warnings:</b>					
The page size in the PDF is too large. The pages should be 8.5 x 11 or A4. If this PDF is submitted, the pages will be resized upon entry into the Image File Wrapper and may affect subsequent processing					
<b>Information:</b>					
2	Other Reference-Patent/App/Search documents	Atmel1424NotOfApp31Jan14.pdf	45558 e10c508f6803f53a9fc5a93f3c5350350f26786d	no	2
<b>Warnings:</b>					
<b>Information:</b>					
3	Other Reference-Patent/App/Search documents	Atmel1424AppInitIntervSum06 Feb14.pdf	262864 a2c1499cf97a5117eb9befb8f1cdc222737b9ea6	no	6
<b>Warnings:</b>					
<b>Information:</b>					
4	Other Reference-Patent/App/Search documents	Atmel1424AppSumIntervEx10 March14.pdf	33985 43358c3233a54b5260ea5a5d007be90031ea9514	no	1
<b>Warnings:</b>					
<b>Information:</b>					
5	Fee Worksheet (SB06)	fee-info.pdf	29901 1184f335dc3924cf39f23e7b7ce3e023bef9e9fa	no	2
<b>Warnings:</b>					
<b>Information:</b>					
<b>Total Files Size (in bytes):</b>			506505		

**This Acknowledgement Receipt evidences receipt on the noted date by the USPTO of the indicated documents, characterized by the applicant, and including page counts, where applicable. It serves as evidence of receipt similar to a Post Card, as described in MPEP 503.**

**New Applications Under 35 U.S.C. 111**

**If a new application is being filed and the application includes the necessary components for a filing date (see 37 CFR 1.53(b)-(d) and MPEP 506), a Filing Receipt (37 CFR 1.54) will be issued in due course and the date shown on this Acknowledgement Receipt will establish the filing date of the application.**

**National Stage of an International Application under 35 U.S.C. 371**

**If a timely submission to enter the national stage of an international application is compliant with the conditions of 35 U.S.C. 371 and other applicable requirements a Form PCT/DO/EO/903 indicating acceptance of the application as a national stage submission under 35 U.S.C. 371 will be issued in addition to the Filing Receipt, in due course.**

**New International Application Filed with the USPTO as a Receiving Office**

**If a new international application is being filed and the international application includes the necessary components for an international filing date (see PCT Article 11 and MPEP 1810), a Notification of the International Application Number and of the International Filing Date (Form PCT/RO/105) will be issued in due course, subject to prescriptions concerning national security, and the date shown on this Acknowledgement Receipt will establish the international filing date of the application.**

**IN THE UNITED STATES PATENT AND TRADEMARK OFFICE**

First Named Inventor: David Brent Guard  
Application No.: 13/312,405  
Filed: December 6, 2011  
Art Unit: 2833  
Confirmation No.: 6025  
Examiner: Ahmed M. Saeed  
Title: *Two-Layer Sensor Sack*

Commissioner for Patents  
P.O. Box 1450  
Alexandria, VA 22313-1450

Dear Sir:

**Supplemental Information Disclosure Statement (IDS)**

Applicant respectfully requests, pursuant to 37 C.F.R. §§ 1.56, 1.97, and 1.98, that the documents listed on the attached PTO/SB/08 Form be considered and cited in the examination of the above-identified patent application. Pursuant to 37 C.F.R. §§ 1.97(g) and (h), Applicant makes no representation that a search has been made, that these documents are material to patentability of the present application, or that these documents qualify as prior art.

Copies of U.S. patents and U.S. patent application publications have not been provided. To the extent applicable, documents other than U.S. patents and U.S. patent application publications are enclosed for the convenience of the Examiner.

No item of information contained in this IDS was cited in a communication from a foreign patent office in a counterpart foreign application, and, to the knowledge of the person signing the certification after making reasonable inquiry, no item of information contained in this IDS was known to any individual designated in § 1.56(c) more than three months prior to the filing of this IDS.

The Commissioner is authorized to charge the amount of \$180.00 under 37 C.F.R. § 1.97(d). Although no other fees are believed to be due, the Commissioner is hereby authorized to charge any additional necessary fees and credit any overpayments to Deposit Account 02-0384 of Baker Botts L.L.P.

Respectfully submitted,  
BAKER BOTTS L.L.P.  
Attorneys for Applicant



Brice S. Dumais  
Reg. No. 65,800

Date: 3/19/14

**CORRESPONDENCE ADDRESS:**

at Customer No. **12323**



UNITED STATES PATENT AND TRADEMARK OFFICE

UNITED STATES DEPARTMENT OF COMMERCE
United States Patent and Trademark Office
Address: COMMISSIONER FOR PATENTS
P.O. Box 1450
Alexandria, Virginia 22313-1450
www.uspto.gov

Table with 5 columns: APPLICATION NO., FILING DATE, FIRST NAMED INVENTOR, ATTORNEY DOCKET NO., CONFIRMATION NO. Includes fields for EXAMINER (SAEED, AHMED M), ART UNIT (2833), PAPER NUMBER, NOTIFICATION DATE (03/06/2014), and DELIVERY MODE (ELECTRONIC).

Please find below and/or attached an Office communication concerning this application or proceeding.

The time period for reply, if any, is set in the attached communication.

Notice of the Office communication was sent electronically on above-indicated "Notification Date" to the following e-mail address(es):

ptomail1@bakerbotts.com
ptomail2@bakerbotts.com



***Claim Rejections - 35 USC § 103***

The text of those sections of Title 35, U.S. Code not included in this action can be found in a prior Office action.

Claims 1, 4, 9, 10, 13, 18 and 19 are rejected under pre-AIA 35 U.S.C. 103(a) as being unpatentable over Hotelling (US 2008/0158183) in view of Bick (US 6,924,789).

**Regarding claim 1**, Hotelling teaches an apparatus comprising: a first optically clear adhesive (OCA) layer 412 between a first cover sheet 408 and a substrate 402; the substrate, with drive or sense electrodes (404 and 406) of a touch sensor disposed on a first surface and a second surface of the substrate, the first surface being opposite the second surface (col. 9, lines 35-45), the drive or sense electrodes being made of a conductive mesh of conductive material comprising metal (fig 4 and col. 2, lines 49-50) and a display 410 separated from the second surface of the substrate by a second OCA 412. Hotelling does not teach the display being separated by a second cover. However, Bick teaches a display 4 separated from the second surface of the substrate 20 by dielectric layer 27 (Bick fig 3, col. 2, lines 38-50). It would have been obvious to one having ordinary skill in the art at the time the invention was made to utilize the teachings of Bick in the touch panel of Hotelling to provide a dielectric barrier between the substrate and the display screen.

**Regarding claim 10**, Hotelling teaches an apparatus comprising: a first cover sheet 408; a first optically clear adhesive (OCA) layer 412 between the first cover sheet and a substrate 402; and the substrate, with drive or sense electrodes (404 and 406) of

Art Unit: 2833

a touch sensor disposed on a first surface and a second surface of the substrate, the first surface being opposite the second surface (col. 9, lines 35-45), the drive or sense electrodes being made of a conductive mesh of conductive material comprising metal (fig 4 and col. 2, lines 49-50) and a display 410 separated from the second surface of the substrate by a second OCA 412, and one or more computer-readable non-transitory storage media embodying logic that is configured when executed to control the touch sensor. Hotelling does not teach the display being separated by a second cover. However, Bick teaches a display 4 separated from the second surface of the substrate 20 by dielectric layer 27 (Bick fig 3, col. 2, lines 38-50). It would have been obvious to one having ordinary skill in the art at the time the invention was made to utilize the teachings of Bick in the touch panel of Hotelling to provide a dielectric barrier between the substrate and the display screen.

**Regarding claim 19,** Hotelling teaches an apparatus comprising: a first optically clear adhesive (OCA) layer 412 between a first cover sheet 408 and a substrate 402; and the substrate, with drive or sense electrodes (404 and 406) of a touch sensor disposed on a first surface and a second surface of the substrate, the first surface being opposite the second surface (col. 9, lines 35-45), the drive or sense electrodes being made of a conductive mesh of conductive material comprising metal ( fig 4 and col. 2, lines 49-50), and a display 410 separated from the second surface of the substrate by a second OCA 412, and one or more computer-readable non-transitory storage media embodying logic that is configured when executed to control the touch sensor. Hotelling does not teach the display being separated by a second cover. However, Bick teaches



a display 4 separated from the second surface of the substrate 20 by dielectric layer 27 (Bick fig 3, col. 2, lines 38-50). It would have been obvious to one having ordinary skill in the art at the time the invention was made to utilize the teachings of Bick in the touch panel of Hotelling to provide a dielectric barrier between the substrate and the display screen.

The features of dependent **claims 4, 9, 13 and 18** are taught by Hotelling, as discussed in the previous Office action, and have not been separately argued by applicant.

Claims 5-8 and 14-17 are rejected under pre-AIA 35 U.S.C. 103(a) as being unpatentable over Hotelling and Bick, as applied to claims 1 and 10 above, and further in view of Frey (US 2009/0219257).

The features of dependent **claims 5-8 and 14-17** are taught by Hotelling and Frey, as discussed in the previous Office action, and have not been separately argued by applicant.

### ***Response to Arguments***

Applicant's arguments filed 12/18/2013 have been fully considered but they are not persuasive.

Applicant argues on page 2 that Hotelling or Bick do not teach the second cover and the second clear adhesive. However, Hotelling does teach a display or LCD 410 separated from a bottom surface of the substrate 402 by an optically clear adhesive

Art Unit: 2833

412, and Bick teaches a display or LCD 4 which is separated from a substrate by a cover 17 and a clear adhesive 27. The combination would yield a first OCA 412 attaching the first cover sheet 408 to the substrate 402 and a second OCA 412 attaching the second cover sheet 14 to the substrate 402, and the second cover sheet separating the display 410 from the substrate. It would have been obvious to one having ordinary skill in the art at the time the invention was made to utilize the teachings of Bick in the touch panel of Hotelling for the purpose of protecting the substrate and to provide a dielectric barrier between the substrate and the display screen.

### ***Conclusion***

Applicant's amendment necessitated the new grounds of rejection presented in this Office action. Accordingly, **THIS ACTION IS MADE FINAL**. Applicant is reminded of the extension of time policy as set forth in 37 CFR 1.136(a).

A shortened statutory period for reply to this final action is set to expire THREE MONTHS from the mailing date of this action. In the event a first reply is filed within TWO MONTHS of the mailing date of this final action and the advisory action is not mailed until after the end of the THREE-MONTH shortened statutory period, then the shortened statutory period will expire on the date the advisory action is mailed, and any extension fee pursuant to 37 CFR 1.136(a) will be calculated from the mailing date of the advisory action. In no event, however, will the statutory period for reply expire later than SIX MONTHS from the mailing date of this final action.

Art Unit: 2833

Any inquiry concerning this communication or earlier communications from the examiner should be directed to AHMED SAEED whose telephone number is (571)270-7976. The examiner can normally be reached on M-F (8:30-5:30pm).

If attempts to reach the examiner by telephone are unsuccessful, the examiner's supervisor, Renee Luebke can be reached on 571-272-2009.

The fax phone number for the organization where this application or proceeding is assigned is 571-273-8300.

Information regarding the status of an application may be obtained from the Patent Application Information Retrieval (PAIR) system. Status information for published applications may be obtained from either Private PAIR or Public PAIR. Status information for unpublished applications is available through Private PAIR only. For more information about the PAIR system, see <http://pair-direct.uspto.gov>. Should you have questions on access to the Private PAIR system, contact the Electronic Business Center (EBC) at 866-217-9197 (toll-free). If you would like assistance from a USPTO Customer Service Representative or access to the automated information system, call 800-786-9199 (IN USA OR CANADA) or 571-272-1000.

/AHMED SAEED/  
Examiner, Art Unit 2833

*/renee luebke/*

Renee Luebke  
Supervisory Patent examiner  
AU 2833

PTO/SB/08  <b>INFORMATION DISCLOSURE STATEMENT BY APPLICANT</b>	<b>Application Number:</b> 13/312,405	<b>First Named Inventor:</b> David Brent Guard	
	<b>Attorney Docket No:</b> 080900.1371	<b>Art Unit:</b> 2833	<b>Filing Date:</b> Dec. 6, 2011

ISSUED U.S. PATENTS AND PUBLISHED U.S. APPLICATIONS			
	DOCUMENT NUMBER	PUBLICATION OR ISSUE DATE	FIRST NAMED INVENTOR
A	2002/0167619	11/2002	Bietsch et al.
B	2004/0239650	12/2004	B. L. Mackey
C	2006/0097991	05/2006	Hotelling et al.
D	2009/0205879	08/2009	Halsey IV et al.
E	2009/0273570	11/2009	Degner et al.
F	2010/0045614	02/2010	Gray et al.
G	2010/0045615	02/2010	Gray et al.
H	2010/0045632	02/2010	Yilmaz et al.
I	2010/0302201	12/2010	Ritter et al.
J	2011/0007020	01/2011	Hong et al.
K	2011/0310033	12/2011	Liu et al.
L	2011/0310037	12/2011	Moran et al.
M	2012/0075238	03/2012	Minami et al.
N	2012/0262382	10/2012	David B. Guard et al.
O	2012/0262412	10/2012	David B. Guard et al.
P	2013/0127772	05/2013	David B. Guard et al.
Q	2013/0234974	09/2013	David B. Guard
R	7,382,139	06/2008	B. L. Mackey
S			

NON-PATENT LITERATURE (NPL)		
	DOCUMENT (Including Author, Title, Source, and Pertinent Pages)	DATE
T	Guard et al., USSN 13/089,061, Non-final Office Action (Attorney Docket 080900.1208)	23 Nov. 2012
U	Guard et al., USSN 13/089,061, Response to Non-final Office Action (Attorney Docket 080900.1208)	25 Mar 2013
V	Guard et al., USSN 13/089,061, Non-final Office Action (Attorney Docket 080900.1208)	20 June 2013
W	Guard et al., USSN 13/089,061, Response to Non-final Office Action (Attorney Docket 080900.1208)	17 Dec. 2013
X	Guard et al., USSN 13/331,022, Non-final Office Action (Attorney's Docket 080900.1370).	07 Oct 2013
Y	Guard et al., USSN 13/331,022, Response to Non-final Office Action (Attorney's Docket 080900.1370).	07 Jan 2014
Z	Guard et al., USSN 13/347,859, Non-final Office Action (Attorney's Docket 080900.1424).	02 Nov 2012

Active 14999400 EXAMINER	DATE CONSIDERED
EXAMINER: Initial if citation considered, whether or not citation is in conformance with MPEP § 609. Draw line through citation if not in conformance and not considered. Include copy of this form with next communication to the applicant.	

U.S. PATENT AND TRADEMARK OFFICE

PTO/SB/08  <b>INFORMATION DISCLOSURE STATEMENT BY APPLICANT</b>	<b>Application Number:</b> 13/312,405	<b>First Named Inventor:</b> David Brent Guard	
	<b>Attorney Docket No:</b> 080900.1371	<b>Art Unit:</b> 2833	<b>Filing Date:</b> Dec. 6, 2011

**ISSUED U.S. PATENTS AND PUBLISHED U.S. APPLICATIONS**

	<b>DOCUMENT NUMBER</b>	<b>PUBLICATION OR ISSUE DATE</b>	<b>FIRST NAMED INVENTOR</b>
A			
B			
C			
D			
E			
F			
G			
H			
I			
J			
K			

**NON-PATENT LITERATURE (NPL)**

	<b>DOCUMENT (Including Author, Title, Source, and Pertinent Pages)</b>	<b>DATE</b>
L	Guard et al., USSN 13/347,859, Response to Non-final Office Action (Attorney's Docket 080900.1424).	04 Mar. 2013
M	Guard et al., USSN 13/347,859, Final Office Action (Attorney's Docket 080900.1424).	21 May 2013
N	Guard et al., USSN 13/347,859, RCE and Response (Attorney's Docket 080900.1424).	20 Sept. 2013
O	Guard et al., USSN 13/347,859, Non-Final Office Action (Attorney's Docket 080900.1424).	01 Nov. 2013
P	Guard, USSN 13/413,306, Non-final Office Action (Attorney's Docket 080900.1425).	08 Oct 2013
Q	Guard, USSN 13/413,306, Response to Non-final Office Action (Attorney's Docket 080900.1425).	08 Jan 2014
R		
S		
T		
U		
V		
W		
R		

Active 14999400 EXAMINER /Ahmed Saeed/	<b>DATE CONSIDERED</b> 02/24/2014
EXAMINER: Initial if citation considered, whether or not citation is in conformance with MPEP § 609. Draw line through citation if not in conformance and not considered. Include copy of this form with next communication to the applicant.	

U.S. PATENT AND TRADEMARK OFFICE

<b>Search Notes</b>  	<b>Application/Control No.</b>  13312405	<b>Applicant(s)/Patent Under Reexamination</b>  GUARD ET AL.
	<b>Examiner</b>  AHMED SAEED	<b>Art Unit</b>  2833

CPC- SEARCHED		
Symbol	Date	Examiner

CPC COMBINATION SETS - SEARCHED		
Symbol	Date	Examiner

US CLASSIFICATION SEARCHED			
Class	Subclass	Date	Examiner

SEARCH NOTES		
Search Notes	Date	Examiner
Inventor name search	7/8/2013	AS
consulted with Renee Luebke	7/8/2013	AS
EAST text search with subclasses (200/512, 345/173, 428, 361)	2/24/2014	AS

INTERFERENCE SEARCH			
US Class/ CPC Symbol	US Subclass / CPC Group	Date	Examiner

--	--

PTO/SB/08  <b>INFORMATION DISCLOSURE STATEMENT BY APPLICANT</b>	<b>Application Number:</b> 13/312,405	<b>First Named Inventor:</b> David Brent Guard	
	<b>Attorney Docket No:</b> 080900.1371	<b>Art Unit:</b> 2833	<b>Filing Date:</b> Dec. 6, 2011

ISSUED U.S. PATENTS AND PUBLISHED U.S. APPLICATIONS			
	DOCUMENT NUMBER	PUBLICATION OR ISSUE DATE	FIRST NAMED INVENTOR
A	2002/0167619	11/2002	Bietsch et al.
B	2004/0239650	12/2004	B. L. Mackey
C	2006/0097991	05/2006	Hotelling et al.
D	2009/0205879	08/2009	Halsey IV et al.
E	2009/0273570	11/2009	Degner et al.
F	2010/0045614	02/2010	Gray et al.
G	2010/0045615	02/2010	Gray et al.
H	2010/0045632	02/2010	Yilmaz et al.
I	2010/0302201	12/2010	Ritter et al.
J	2011/0007020	01/2011	Hong et al.
K	2011/0310033	12/2011	Liu et al.
L	2011/0310037	12/2011	Moran et al.
M	2012/0075238	03/2012	Minami et al.
N	2012/0262382	10/2012	David B. Guard et al.
O	2012/0262412	10/2012	David B. Guard et al.
P	2013/0127772	05/2013	David B. Guard et al.
Q	2013/0234974	09/2013	David B. Guard
R	7,382,139	06/2008	B. L. Mackey
S			

NON-PATENT LITERATURE (NPL)		
	DOCUMENT (Including Author, Title, Source, and Pertinent Pages)	DATE
T	Guard et al., USSN 13/089,061, Non-final Office Action (Attorney Docket 080900.1208)	23 Nov. 2012
U	Guard et al., USSN 13/089,061, Response to Non-final Office Action (Attorney Docket 080900.1208)	25 Mar 2013
V	Guard et al., USSN 13/089,061, Non-final Office Action (Attorney Docket 080900.1208)	20 June 2013
W	Guard et al., USSN 13/089,061, Response to Non-final Office Action (Attorney Docket 080900.1208)	17 Dec. 2013
X	Guard et al., USSN 13/331,022, Non-final Office Action (Attorney's Docket 080900.1370).	07 Oct 2013
Y	Guard et al., USSN 13/331,022, Response to Non-final Office Action (Attorney's Docket 080900.1370).	07 Jan 2014
Z	Guard et al., USSN 13/347,859, Non-final Office Action (Attorney's Docket 080900.1424).	02 Nov 2012

Active 14999400 EXAMINER	DATE CONSIDERED
EXAMINER: Initial if citation considered, whether or not citation is in conformance with MPEP § 609. Draw line through citation if not in conformance and not considered. Include copy of this form with next communication to the applicant.	

PTO/SB/08  <b>INFORMATION DISCLOSURE STATEMENT BY APPLICANT</b>	<b>Application Number:</b> 13/312,405	<b>First Named Inventor:</b> David Brent Guard	
	<b>Attorney Docket No:</b> 080900.1371	<b>Art Unit:</b> 2833	<b>Filing Date:</b> Dec. 6, 2011

**ISSUED U.S. PATENTS AND PUBLISHED U.S. APPLICATIONS**

	<b>DOCUMENT NUMBER</b>	<b>PUBLICATION OR ISSUE DATE</b>	<b>FIRST NAMED INVENTOR</b>
A			
B			
C			
D			
E			
F			
G			
H			
I			
J			
K			

**NON-PATENT LITERATURE (NPL)**

	<b>DOCUMENT (Including Author, Title, Source, and Pertinent Pages)</b>	<b>DATE</b>
L	Guard et al., USSN 13/347,859, Response to Non-final Office Action (Attorney's Docket 080900.1424).	04 Mar. 2013
M	Guard et al., USSN 13/347,859, Final Office Action (Attorney's Docket 080900.1424).	21 May 2013
N	Guard et al., USSN 13/347,859, RCE and Response (Attorney's Docket 080900.1424).	20 Sept. 2013
O	Guard et al., USSN 13/347,859, Non-Final Office Action (Attorney's Docket 080900.1424).	01 Nov. 2013
P	Guard, USSN 13/413,306, Non-final Office Action (Attorney's Docket 080900.1425).	08 Oct 2013
Q	Guard, USSN 13/413,306, Response to Non-final Office Action (Attorney's Docket 080900.1425).	08 Jan 2014
R		
S		
T		
U		
V		
W		
R		

Active 14999400 EXAMINER	DATE CONSIDERED
-----------------------------	-----------------

EXAMINER: Initial if citation considered, whether or not citation is in conformance with MPEP § 609. Draw line through citation if not in conformance and not considered. Include copy of this form with next communication to the applicant.



## Electronic Patent Application Fee Transmittal

<b>Application Number:</b>	13312405
<b>Filing Date:</b>	06-Dec-2011
<b>Title of Invention:</b>	Two-Layer Sensor Stack
<b>First Named Inventor/Applicant Name:</b>	David Brent Guard
<b>Filer:</b>	Stanton Aaron Lewis/Esmarie Garland
<b>Attorney Docket Number:</b>	080900.1371

Filed as Large Entity

### Utility under 35 USC 111(a) Filing Fees

Description	Fee Code	Quantity	Amount	Sub-Total in USD(\$)
<b>Basic Filing:</b>				
<b>Pages:</b>				
<b>Claims:</b>				
<b>Miscellaneous-Filing:</b>				
<b>Petition:</b>				
<b>Patent-Appeals-and-Interference:</b>				
<b>Post-Allowance-and-Post-Issuance:</b>				
<b>Extension-of-Time:</b>				

Description	Fee Code	Quantity	Amount	Sub-Total in USD(\$)
<b>Miscellaneous:</b>				
Submission- Information Disclosure Stmt	1806	1	180	180
<b>Total in USD (\$)</b>				<b>180</b>

## Electronic Acknowledgement Receipt

<b>EFS ID:</b>	18129213
<b>Application Number:</b>	13312405
<b>International Application Number:</b>	
<b>Confirmation Number:</b>	6025
<b>Title of Invention:</b>	Two-Layer Sensor Stack
<b>First Named Inventor/Applicant Name:</b>	David Brent Guard
<b>Customer Number:</b>	12323
<b>Filer:</b>	Stanton Aaron Lewis/Esmarie Garland
<b>Filer Authorized By:</b>	Stanton Aaron Lewis
<b>Attorney Docket Number:</b>	080900.1371
<b>Receipt Date:</b>	06-FEB-2014
<b>Filing Date:</b>	06-DEC-2011
<b>Time Stamp:</b>	11:06:54
<b>Application Type:</b>	Utility under 35 USC 111(a)

### Payment information:

Submitted with Payment	yes
Payment Type	Deposit Account
Payment was successfully received in RAM	\$180
RAM confirmation Number	7200
Deposit Account	020384
Authorized User	

The Director of the USPTO is hereby authorized to charge indicated fees and credit any overpayment as follows:

Charge any Additional Fees required under 37 C.F.R. Section 1.16 (National application filing, search, and examination fees)

Charge any Additional Fees required under 37 C.F.R. Section 1.17 (Patent application and reexamination procedure fees)

PETITIONERS

Charge any Additional Fees required under 37 C.F.R. Section 1.19 (Document supply fees)

Charge any Additional Fees required under 37 C.F.R. Section 1.20 (Post Issuance fees)

Charge any Additional Fees required under 37 C.F.R. Section 1.21 (Miscellaneous fees and charges)

**File Listing:**

Document Number	Document Description	File Name	File Size(Bytes)/ Message Digest	Multi Part /.zip	Pages (if appl.)
1		0809001371SupplDS.PDF	218748 12c23250a904adfb2ed8354c9b85e2d9d9e5f7f	yes	4

**Multipart Description/PDF files in .zip description**

Document Description	Start	End
Transmittal Letter	1	2
Information Disclosure Statement (IDS) Form (SB08)	3	4

**Warnings:**

The page size in the PDF is too large. The pages should be 8.5 x 11 or A4. If this PDF is submitted, the pages will be resized upon entry into the Image File Wrapper and may affect subsequent processing

**Information:**

2	Other Reference-Patent/App/Search documents	Atmel1208NFOA23Nov12.pdf	712360 7eeac276254ba2f2a9db4629c7005eeef492e3a	no	22
---	---	--------------------------	---	----	----

**Warnings:**

**Information:**

3	Other Reference-Patent/App/Search documents	Atmel1208Response25Mar13.pdf	687039 7bf5a89e50e527259824633c38ce3b60f20d776d	no	14
---	---	------------------------------	--	----	----

**Warnings:**

**Information:**

4	Other Reference-Patent/App/Search documents	Atmel1208NFOA20June13.pdf	608024 9513987463dd107af94cbf59b0c0da09cdaec756	no	19
---	---	---------------------------	--	----	----

**Warnings:**

**Information:**

5	Other Reference-Patent/App/Search documents	Atmel1208Response17Dec13.pdf	548917 4a4ff4f3fa1ec64d5d66fea44fe72f4c15b08a21	no	13
---	---	------------------------------	--	----	----

**Warnings:**

**Information:**

6	Other Reference-Patent/App/Search documents	Atmel1370NFOA07Oct13.pdf	485361 017f8c69e085fb75a5396180452bcd8848e7e485	no	16
---	---	--------------------------	--	----	----

**Warnings:**

**Information:**

PETITIONERS

7	Other Reference-Patent/App/Search documents	Atmel1370Response07Jan14.pdf	402976 bbb64532cfc14f61288ca36645c34abdffb85fe	no	10
<b>Warnings:</b>					
<b>Information:</b>					
8	Other Reference-Patent/App/Search documents	Atmel1424NFOA02Nov12.pdf	431474 7a7e207b9e98f30b06c483d103f1afb95e4456	no	14
<b>Warnings:</b>					
<b>Information:</b>					
9	Other Reference-Patent/App/Search documents	Atmel1424Response04March13.pdf	517364 6d130dd4adfb40e24ad47a5c19f928ae4fc057a4	no	12
<b>Warnings:</b>					
<b>Information:</b>					
10	Other Reference-Patent/App/Search documents	Atmel1424FOA21May13.pdf	435390 261a9dac2f2e5454c4e3ad10b14a6a504c3dc66e	no	13
<b>Warnings:</b>					
<b>Information:</b>					
11	Other Reference-Patent/App/Search documents	Atmel1424RCEandAmendment20Sept13.pdf	615691 9da628a26d8bfa4e4edbf6578ccb34d7fec145	no	13
<b>Warnings:</b>					
<b>Information:</b>					
12	Other Reference-Patent/App/Search documents	Atmel1424NFOA01Nov13.pdf	416058 293bf7028e231ade0000267cdb1f360a36ef7f3b	no	13
<b>Warnings:</b>					
<b>Information:</b>					
13	Other Reference-Patent/App/Search documents	Atmel1425NFOA08Oct13.pdf	550868 65d48fcd6ac7ab9619a4f5b04feaca9447d821c0	no	17
<b>Warnings:</b>					
<b>Information:</b>					
14	Other Reference-Patent/App/Search documents	Atmel1425Response08Jan14.pdf	499790 52d6e17968d84d6e798a45f643f3399dc71cf39e	no	13
<b>Warnings:</b>					
<b>Information:</b>					
15	Fee Worksheet (SB06)	fee-info.pdf	29901 bf4ec4a3ef412e74ceea8bc04233fbf54a1e8551	no	2
<b>Warnings:</b>					
<b>Information:</b>					

**This Acknowledgement Receipt evidences receipt on the noted date by the USPTO of the indicated documents, characterized by the applicant, and including page counts, where applicable. It serves as evidence of receipt similar to a Post Card, as described in MPEP 503.**

**New Applications Under 35 U.S.C. 111**

**If a new application is being filed and the application includes the necessary components for a filing date (see 37 CFR 1.53(b)-(d) and MPEP 506), a Filing Receipt (37 CFR 1.54) will be issued in due course and the date shown on this Acknowledgement Receipt will establish the filing date of the application.**

**National Stage of an International Application under 35 U.S.C. 371**

**If a timely submission to enter the national stage of an international application is compliant with the conditions of 35 U.S.C. 371 and other applicable requirements a Form PCT/DO/EO/903 indicating acceptance of the application as a national stage submission under 35 U.S.C. 371 will be issued in addition to the Filing Receipt, in due course.**

**New International Application Filed with the USPTO as a Receiving Office**

**If a new international application is being filed and the international application includes the necessary components for an international filing date (see PCT Article 11 and MPEP 1810), a Notification of the International Application Number and of the International Filing Date (Form PCT/RO/105) will be issued in due course, subject to prescriptions concerning national security, and the date shown on this Acknowledgement Receipt will establish the international filing date of the application.**

ATTORNEY DOCKET NO.:  
080900.1371  
(10045QRG-COA)

PATENT APPLICATION  
USSN 13/312,405

1 of 2

**IN THE UNITED STATES PATENT AND TRADEMARK OFFICE**

First Named Inventor: David Brent Guard  
Serial No.: 13/312,405  
Filing Date: December 6, 2011  
Art Unit: 2833  
Confirmation No.: 6025  
Examiner: Ahmed M. Saeed  
Title: *Two-Layer Sensor Stack*

Commissioner of Patents  
PO Box 1450  
Alexandria, VA 22313-1450

Dear Sir:

**Supplemental Information Disclosure Statement (IDS)**

Applicant respectfully requests, pursuant to 37 C.F.R. §§ 1.56, 1.97, and 1.98, that the documents listed on the attached PTO SB/08 form be considered and cited in the examination of the above-identified patent application. Pursuant to 37 C.F.R. §§ 1.97 (g) and (h), Applicant makes no representation that a search has been made, that these documents are material to patentability of the present application, or that these documents qualify as prior art.

ATTORNEY DOCKET NO.:  
080900.1371  
(10045QRG-COA)

PATENT APPLICATION  
USSN 13/312,405

2 of 2

Copies of U.S. patents and U.S. patent application publications have not been provided. To the extent applicable, documents other than the U.S. patents and U.S. patent application publications are enclosed for the convenience of the Examiner.

This Supplemental IDS is being submitted after the mailing of a first Office Action. Thus, the Commissioner is authorized to charge the amount of \$180.00 to Deposit Account No. 02-0384 of Baker Botts L.L.P. Although no additional fees are believed to be due for this Supplemental IDS, the Commissioner is authorized to charge any additional necessary fees and credit any overpayments to Deposit Account No. 02-0384 of Baker Botts L.L.P.

Respectfully submitted,  
BAKER BOTTS L.L.P.  
Attorneys for Applicant



Brice S. Dumais  
Reg. No. 65,800

Date: 2/5/14

Correspondence Address:

**Customer No. 12323**



**IN THE UNITED STATES PATENT AND TRADEMARK OFFICE**

First Named Inventor: Brent David Guard  
Serial No.: 13/312,405  
Filing Date: December 11, 2011  
Art Unit: 2833  
Confirmation No.: 6025  
Examiner: Ahmed M Saeed  
Title: *Two-Layer Sensor Stack*

**Response Under 37 C.F.R. § 1.111**

In response to the Non-Final Office Action dated July 19, 2013, Applicants respectfully request the Examiner to reconsider the rejections of the claims in view of the following amendments and remarks. Please amend the Application as follows.

**In the Claims:**

1. (Currently Amended) An apparatus comprising:

[[an]]a first optically clear adhesive (OCA) layer between a first cover sheet and a substrate; ~~and~~

the substrate, with drive or sense electrodes of a touch sensor disposed on a first surface and a second surface of the substrate, the first surface being opposite the second surface, the drive or sense electrodes being made of a conductive mesh conductive material comprising metal; and

a display separated from the second surface of the substrate by a second OCA and a second cover sheet.

2-3. (Canceled)

4. (Original) The apparatus of Claim 1, wherein the conductive material is copper, silver, gold, aluminum, or tin.

5. (Original) The apparatus of Claim 1, wherein the conductive mesh comprises a plurality of mesh segments, each of the mesh segments having a width of approximately 10  $\mu\text{m}$ .

6. (Original) The apparatus of Claim 5, wherein approximately 5% of an active area of the touch sensor is covered by the one or more mesh segments.

7. (Original) The apparatus of Claim 5, wherein each of the mesh segments is substantially sinusoidal.

8. (Original) The apparatus of Claim 1, wherein the conductive meshes have an optical transmissivity of approximately 90%.

9. (Original) The apparatus of Claim 1, wherein the sense electrodes being disposed on the first surface of the substrate and the drive electrodes being disposed on the second surface of the substrate.

10. (Currently Amended) ~~[[An]]~~ A device comprising:

a first cover sheet;

~~[[an]]~~ a first optically clear adhesive layer (OCA) between the first cover sheet and a substrate;

the substrate, with drive or sense electrodes of a touch sensor disposed on a first surface and a second surface of the substrate, the first surface being opposite the second surface, the drive or sense electrodes being made of a conductive mesh conductive material comprising metal;

a display separated from the second surface of the substrate by a second OCA and a second cover sheet; and

one or more computer-readable non-transitory storage media embodying logic that is configured when executed to control the touch sensor.

11-12. (Canceled)

13. (Original) The device of Claim 10, wherein the conductive material is copper, silver, gold, aluminum, or tin.

14. (Original) The device of Claim 10, wherein the conductive mesh comprises a plurality of mesh segments, each of the mesh segments having a width of approximately 10  $\mu\text{m}$ .

15. (Original) The device of Claim 14, wherein approximately 5% of an active area of the touch sensor is covered by the mesh segments.

16. (Original) The device of Claim 14, wherein each of the mesh segments is substantially sinusoidal.

17. (Original) The device of Claim 10, wherein the conductive meshes have an optical transmissivity of approximately 90%.

18. (Original) The device of Claim 10, wherein the sense electrodes being disposed on the first surface of the substrate and the drive electrodes being disposed on the second surface of the substrate.

19. (Currently Amended) An apparatus comprising:

[[an]] a first optically clear adhesive (OCA) layer between a first cover sheet and a substrate; ~~and~~

the substrate, with sense electrodes of a touch sensor disposed on a first surface and drive electrodes of the touch sensor disposed on a second surface of the substrate, the first surface being opposite the second surface, the drive and sense electrodes being made of a conductive mesh of conductive material comprising metal; and

a display separated from the second surface of the substrate by a second OCA and a second cover sheet.

20. (Canceled)

**Remarks**

This Application has been reviewed carefully in light of the Non-Final Office Action dated July 19, 2013. Applicant appreciates the Examiner's consideration of the Application. Although Applicant believes all claims are allowable without amendment, to advance prosecution Applicant has made clarifying amendments to Claims 1, 10, and 19. Claims 2-3, 11-12, and 20 have been cancelled without prejudice or disclaimer. At least certain of these amendments are not considered narrowing, and none are considered necessary for patentability. Additionally, Applicant does not admit that these amendments are made in response to or necessitated by any cited reference or combination of cited references. Applicant respectfully requests reconsideration and allowance of all pending claims.

**The Claims are Allowable over *Hotelling* and the Proposed *Hotelling-Bick* Combination**

The Office Action rejects Claims 1, 4, 9-10, and 18-19 under 35 U.S.C. § 102(b) as being anticipated by U.S. Patent Application Publication No. 2008/0158183 ("*Hotelling*"). The Office Action rejects Claims 2-3, 11-12, and 20 under 35 U.S.C. § 103(a) as being unpatentable over U.S. Patent 6,924,789 ("*Bick*"). Applicant respectfully traverses these rejections and discusses independent Claim 1 as an example.

Amended independent Claim 1, which has been amended to include at least certain limitations analogous to those recited in previously pending Claims 2 and 3, recites the following:

An apparatus comprising:  
a first optically clear adhesive (OCA) layer between a first cover sheet and a substrate;  
the substrate, with drive or sense electrodes of a touch sensor disposed on a first surface and a second surface of the substrate, the first surface being opposite the second surface, the drive or sense electrodes being made of a conductive mesh conductive material comprising metal; and  
a display separated from the second surface of the substrate by a second OCA and a second cover sheet.

The cited portions of *Hotelling* do not appear to disclose, teach, or suggest various limitations recited in independent Claim 1.

For example, at a minimum, *Hotelling* does not appear to disclose, teach, or suggest “a display separated from the second surface of the substrate by a second OCA and a second cover sheet,” as recited in amended Claim 1. At best, the cited portions of *Hotelling* appear to disclose a touch sensor panel that uses a transparent adhesive between a substrate and a display. *See Hotelling* in Fig. 4, elements 402, 410, and 412 and at col. 8, ll 34-46. However, even assuming for the sake of argument only that the transparent adhesive in *Hotelling* could be equated to the claimed second OCA (which Applicant does not concede), the cited portions of *Hotelling* still would not disclose, teach, or suggest “a display separated from the second surface of the substrate by a second OCA and a second cover sheet,” as recited in amended independent Claim 1.

Additionally, to the extent the Office would point to *Bick* as allegedly making up for at least these deficiencies of *Hotelling*, Applicants submit that *Bick* fails to make up for at least the above-discussed deficiencies of *Hotelling*. For example, at a minimum, *Bick* does not appear to disclose, teach, or suggest “a display separated from the second surface of the substrate by a second OCA and a second cover sheet,” as recited in amended Claim 1. *Bick* appears to disclose a mobile telephone handset with a liquid crystal display (LCD) and a separate keypad. *See, e.g., Bick* in Figure 1, elements 4 and 7 and at col. 2, ll 36-41. Moreover, *Bick* appears to disclose that the keypad includes an optical adhesive layer bonding a sensor to the keymat. *See, e.g., Bick* in Figure 3, elements 17, 19, and 27 and at col. 2, ll 63-65. However, even assuming for the sake of argument only that the keypad in *Bick* could be equated to the second cover sheet (which the Office alleges, but Applicant does not concede), the cited portions of *Bick* still would not disclose, teach, or suggest “a display separated from the second surface of the substrate by a second OCA and a second cover sheet,” as recited in amended independent Claim 1.

Additionally, Applicant does not admit that the proposed *Hotelling-Bick* combination is possible or that the Office Action provides an adequate reason for combining or modifying these references in the proposed manner. To avoid burdening the record and in view of the allowability of independent Claim 1 for at least the above-discussed reasons, Applicant does not discuss this issue in this submission. However, Applicant reserves the right to discuss this issue in a future submission, if appropriate.

For at least these reasons, Applicant respectfully requests reconsideration and allowance of independent Claim 1 and its dependent claims. For at least certain analogous reasons, Applicant respectfully requests reconsideration and allowance of independent Claims 10 and 19 and their dependent claims.

**Claims 5-8 and 14-17 are Allowable over the Proposed *Hotelling-Frey* Combination**

The Office Action rejects Claims 5-8 and 14-17 under 35 U.S.C. § 103(a) as being unpatentable over *Hotelling* in view of U.S. Patent Application Publication No. 2009/0219257 (“*Frey*”). Applicant respectfully traverses these rejections. Claims 5-8 and 14-17 depend from independent Claims 1 and 10, respectively, shown above to be allowable over *Hotelling* and the proposed *Hotelling-Bick* combination. The cited portions of *Frey* do not appear to make up for at least the above-discussed deficiencies of *Hotelling* and the proposed *Hotelling-Bick* combination. Thus, dependent Claims 5-8 and 14-17 are allowable at least because they depend from allowable independent claims. Furthermore, dependent Claims 5-8 and 14-17 recited further patentable features. To avoid burdening the record and in view of the allowability of the independent claims, Applicant does not discuss these features in this submission. Applicant, however, reserves the right to discuss these features in a future submission, if appropriate. Moreover, Applicant does not admit that the proposed *Hotelling-Frey* combination (or a potential *Hotelling-Bick-Frey* combination) is possible or that the Office Action provides an adequate reason for combining or modifying the references in the manner proposed in the Office Action. For at least these reasons, Applicant respectfully requests reconsideration and allowance of Claims 5-8 and 14-17.

**Request for Evidentiary Support**

Should a rejection based on any of the above-asserted rejections be maintained, Applicant respectfully requests appropriate evidentiary support. Additionally, if the Examiner is relying upon “common knowledge” or “well known” principles to establish the rejection, Applicant requests that a reference be provided in support of this position pursuant to M.P.E.P. § 2144.03. Furthermore, to the extent that the Examiner maintains any rejection based on an “Official Notice” or other information within the Examiner’s personal knowledge, Applicant respectfully requests that the Examiner cite a reference as documentary evidence in support of this position or provide an affidavit in accordance with M.P.E.P. § 2144.03 and 37 C.F.R. 1.104(d)(2).

**No Waiver**

Applicant's arguments and amendments are made without prejudice or disclaimer. Additionally, Applicant has merely discussed example distinctions from the cited references. Other distinctions may exist, and Applicant reserves the right to discuss these additional distinctions in a later submission, if appropriate. By not responding to additional statements made by the Office Action, Applicant does not acquiesce to those additional statements.



**Conclusion**

Applicant has made an earnest attempt to place this Application in condition for allowance. For at least the foregoing reasons, Applicant respectfully requests full allowance of all pending claims.

If the Examiner believes a telephone conference would advance prosecution of this Application in any way, the Examiner is invited to contact Chad D. Terrell, Attorney for Applicant, at (214) 953-6813, at the Examiner's convenience.

Please charge \$600.00 for a two-month extension of time fee to Deposit Account No. 02-0384 of Baker Botts L.L.P. Applicant believes no other fee is due; however, the Commissioner is authorized to charge any necessary additional fees and credit any overpayments to Deposit Account No. 02-0384 of Baker Botts L.L.P.

Respectfully submitted,

BAKER BOTTS L.L.P.  
Attorneys for Applicants

/Chad Terrell/

Chad D. Terrell  
Reg. No. 52,279

Date: December 18, 2013

Correspondence Address:

Customer No. **12323**

## Electronic Patent Application Fee Transmittal

<b>Application Number:</b>	13312405
<b>Filing Date:</b>	06-Dec-2011
<b>Title of Invention:</b>	Two-Layer Sensor Stack
<b>First Named Inventor/Applicant Name:</b>	David Brent Guard
<b>Filer:</b>	Russell Clayton Gee/Nancy Pizzo
<b>Attorney Docket Number:</b>	080900.1371

Filed as Large Entity

### Utility under 35 USC 111(a) Filing Fees

Description	Fee Code	Quantity	Amount	Sub-Total in USD(\$)
<b>Basic Filing:</b>				
<b>Pages:</b>				
<b>Claims:</b>				
<b>Miscellaneous-Filing:</b>				
<b>Petition:</b>				
<b>Patent-Appeals-and-Interference:</b>				
<b>Post-Allowance-and-Post-Issuance:</b>				
<b>Extension-of-Time:</b>				
Extension - 2 months with \$0 paid	1252	1	600	PETITIONERS 600

Description	Fee Code	Quantity	Amount	Sub-Total in USD(\$)
<b>Miscellaneous:</b>				
<b>Total in USD (\$)</b>				<b>600</b>

## Electronic Acknowledgement Receipt

<b>EFS ID:</b>	17693990
<b>Application Number:</b>	13312405
<b>International Application Number:</b>	
<b>Confirmation Number:</b>	6025
<b>Title of Invention:</b>	Two-Layer Sensor Stack
<b>First Named Inventor/Applicant Name:</b>	David Brent Guard
<b>Customer Number:</b>	12323
<b>Filer:</b>	Russell Clayton Gee/Nancy Pizzo
<b>Filer Authorized By:</b>	Russell Clayton Gee
<b>Attorney Docket Number:</b>	080900.1371
<b>Receipt Date:</b>	18-DEC-2013
<b>Filing Date:</b>	06-DEC-2011
<b>Time Stamp:</b>	13:08:57
<b>Application Type:</b>	Utility under 35 USC 111(a)

### Payment information:

Submitted with Payment	yes
Payment Type	Deposit Account
Payment was successfully received in RAM	\$600
RAM confirmation Number	11977
Deposit Account	020384
Authorized User	

The Director of the USPTO is hereby authorized to charge indicated fees and credit any overpayment as follows:

Charge any Additional Fees required under 37 C.F.R. Section 1.17 (Patent application and reexamination processing fees)

Charge any Additional Fees required under 37 C.F.R. Section 1.19 (Document supply fees)

PETITIONERS

**File Listing:**

Document Number	Document Description	File Name	File Size(Bytes)/ Message Digest	Multi Part /.zip	Pages (if appl.)
1		080900_1371_ROA_18Dec13.pdf	42738 0e7270f96517a79568813b0a6a5c002368b5b1a1	yes	9
<b>Multipart Description/PDF files in .zip description</b>					
	<b>Document Description</b>		<b>Start</b>	<b>End</b>	
	Amendment/Req. Reconsideration-After Non-Final Reject		1	1	
	Claims		2	4	
	Applicant Arguments/Remarks Made in an Amendment		5	9	
<b>Warnings:</b>					
<b>Information:</b>					
2	Fee Worksheet (SB06)	fee-info.pdf	30362 8e7029997073b51ee3f0491af8415cec6e8bddec	no	2
<b>Warnings:</b>					
<b>Information:</b>					
<b>Total Files Size (in bytes):</b>			73100		

**This Acknowledgement Receipt evidences receipt on the noted date by the USPTO of the indicated documents, characterized by the applicant, and including page counts, where applicable. It serves as evidence of receipt similar to a Post Card, as described in MPEP 503.**

**New Applications Under 35 U.S.C. 111**

**If a new application is being filed and the application includes the necessary components for a filing date (see 37 CFR 1.53(b)-(d) and MPEP 506), a Filing Receipt (37 CFR 1.54) will be issued in due course and the date shown on this Acknowledgement Receipt will establish the filing date of the application.**

**National Stage of an International Application under 35 U.S.C. 371**

**If a timely submission to enter the national stage of an international application is compliant with the conditions of 35 U.S.C. 371 and other applicable requirements a Form PCT/DO/EO/903 indicating acceptance of the application as a national stage submission under 35 U.S.C. 371 will be issued in addition to the Filing Receipt, in due course.**

**New International Application Filed with the USPTO as a Receiving Office**

**If a new international application is being filed and the international application includes the necessary components for an international filing date (see PCT Article 11 and MPEP 1810), a Notification of the International Application Number and of the International Filing Date (Form PCT/RO/105) will be issued in due course, subject to prescriptions concerning national security, and the date shown on this Acknowledgement Receipt will establish the international filing date of the application.**

Under the Paperwork Reduction Act of 1995, no persons are required to respond to a collection of information unless it displays a valid OMB control number.

<b>PATENT APPLICATION FEE DETERMINATION RECORD</b> Substitute for Form PTO-875	Application or Docket Number <b>13/312,405</b>	Filing Date <b>12/06/2011</b>	<input type="checkbox"/> To be Mailed
---	---	----------------------------------	---------------------------------------

ENTITY:  LARGE  SMALL  MICRO

**APPLICATION AS FILED – PART I**

FOR	NUMBER FILED	NUMBER EXTRA	RATE (\$)	FEE (\$)
<input type="checkbox"/> BASIC FEE <small>(37 CFR 1.16(a), (b), or (c))</small>	N/A	N/A	N/A	
<input type="checkbox"/> SEARCH FEE <small>(37 CFR 1.16(k), (l), or (m))</small>	N/A	N/A	N/A	
<input type="checkbox"/> EXAMINATION FEE <small>(37 CFR 1.16(o), (p), or (q))</small>	N/A	N/A	N/A	
TOTAL CLAIMS <small>(37 CFR 1.16(i))</small>	minus 20 =	*	X \$ =	
INDEPENDENT CLAIMS <small>(37 CFR 1.16(h))</small>	minus 3 =	*	X \$ =	
<input type="checkbox"/> APPLICATION SIZE FEE <small>(37 CFR 1.16(s))</small>	If the specification and drawings exceed 100 sheets of paper, the application size fee due is \$310 (\$155 for small entity) for each additional 50 sheets or fraction thereof. See 35 U.S.C. 41(a)(1)(G) and 37 CFR 1.16(s).			
<input type="checkbox"/> MULTIPLE DEPENDENT CLAIM PRESENT <small>(37 CFR 1.16(j))</small>				
<small>* If the difference in column 1 is less than zero, enter "0" in column 2.</small>			TOTAL	

**APPLICATION AS AMENDED – PART II**

	(Column 1)	(Column 2)	(Column 3)	PRESENT EXTRA	RATE (\$)	ADDITIONAL FEE (\$)
<b>AMENDMENT</b>	<b>12/18/2013</b>	CLAIMS REMAINING AFTER AMENDMENT	HIGHEST NUMBER PREVIOUSLY PAID FOR			
	Total <small>(37 CFR 1.16(i))</small>	* 15	Minus	** 20	= 0	X \$80 = 0
	Independent <small>(37 CFR 1.16(h))</small>	* 3	Minus	***3	= 0	X \$420 = 0
	<input type="checkbox"/> Application Size Fee <small>(37 CFR 1.16(s))</small>					
	<input type="checkbox"/> FIRST PRESENTATION OF MULTIPLE DEPENDENT CLAIM <small>(37 CFR 1.16(j))</small>					
					TOTAL ADD'L FEE	<b>0</b>

	(Column 1)	(Column 2)	(Column 3)	PRESENT EXTRA	RATE (\$)	ADDITIONAL FEE (\$)
<b>AMENDMENT</b>		CLAIMS REMAINING AFTER AMENDMENT	HIGHEST NUMBER PREVIOUSLY PAID FOR			
	Total <small>(37 CFR 1.16(i))</small>	*	Minus	**	=	X \$ =
	Independent <small>(37 CFR 1.16(h))</small>	*	Minus	***	=	X \$ =
	<input type="checkbox"/> Application Size Fee <small>(37 CFR 1.16(s))</small>					
	<input type="checkbox"/> FIRST PRESENTATION OF MULTIPLE DEPENDENT CLAIM <small>(37 CFR 1.16(j))</small>					
					TOTAL ADD'L FEE	

\* If the entry in column 1 is less than the entry in column 2, write "0" in column 3.  
 \*\* If the "Highest Number Previously Paid For" IN THIS SPACE is less than 20, enter "20".  
 \*\*\* If the "Highest Number Previously Paid For" IN THIS SPACE is less than 3, enter "3".

The "Highest Number Previously Paid For" (Total or Independent) is the highest number found in the appropriate box in column 1.

LIE  
/SHOWANE SMITH/

This collection of information is required by 37 CFR 1.16. The information is required to obtain or retain a benefit by the public which is to file (and by the USPTO to process) an application. Confidentiality is governed by 35 U.S.C. 122 and 37 CFR 1.14. This collection is estimated to take 12 minutes to complete, including gathering, preparing, and submitting the completed application form to the USPTO. Time will vary depending upon the individual case. Any comments on the amount of time you require to complete this form and/or suggestions for reducing this burden, should be sent to the Chief Information Officer, U.S. Patent and Trademark Office, U.S. Department of Commerce, P.O. Box 1450, Alexandria, VA 22313-1450. DO NOT SEND FEES OR COMPLETED FORMS TO THIS ADDRESS. **SEND TO: Commissioner for Patents, P.O. Box 1450, Alexandria, VA 22313-1450.**

*If you need assistance in completing the form, call 1-800-PTO-9199 and select option 2.*



UNITED STATES PATENT AND TRADEMARK OFFICE

UNITED STATES DEPARTMENT OF COMMERCE
United States Patent and Trademark Office
Address: COMMISSIONER FOR PATENTS
P.O. Box 1450
Alexandria, Virginia 22313-1450
www.uspto.gov

Table with 5 columns: APPLICATION NO., FILING DATE, FIRST NAMED INVENTOR, ATTORNEY DOCKET NO., CONFIRMATION NO. Includes sub-tables for EXAMINER, ART UNIT, PAPER NUMBER, NOTIFICATION DATE, and DELIVERY MODE.

Please find below and/or attached an Office communication concerning this application or proceeding.

The time period for reply, if any, is set in the attached communication.

Notice of the Office communication was sent electronically on above-indicated "Notification Date" to the following e-mail address(es):

ptomail1@bakerbotts.com
ptomail2@bakerbotts.com





## DETAILED ACTION

### ***Claim Rejections - 35 USC § 102***

The following is a quotation of the appropriate paragraphs of pre-AIA 35 U.S.C. 102 that form the basis for the rejections under this section made in this Office action:

A person shall be entitled to a patent unless –  
(b) the invention was patented or described in a printed publication in this or a foreign country or in public use or on sale in this country, more than one year prior to the date of application for patent in the United States.

Claims 1, 4, 9, 10, 18 and 19 are rejected under pre-AIA 35 U.S.C. 102(b) as being anticipated by Hotelling (US 2008/0158183).

**Regarding claim 1**, Hotelling teaches an apparatus comprising: an optically clear adhesive (OCA) layer 412 between the cover sheet 410 and a substrate 402; and the substrate, with drive or sense electrodes (404 and 406) of a touch sensor disposed on a first surface and a second surface of the substrate, the first surface being opposite the second surface (col. 9, lines 35-45), the drive or sense electrodes being made of a conductive mesh of conductive material comprising metal (fig 4 and col. 2, lines 49-50).

**Regarding claim 10**, Hotelling teaches an apparatus comprising: a cover 410; an optically clear adhesive (OCA) layer 412 between the cover sheet 410 and a substrate 402; and the substrate, with drive or sense electrodes (404 and 406) of a touch sensor disposed on a first surface and a second surface of the substrate, the first surface being opposite the second surface (col. 9, lines 35-45), the drive or sense electrodes being made of a conductive mesh of conductive material comprising metal (fig 4 and col. 2, lines 49-50).

Art Unit: 2833

**Regarding claim 19**, Hotelling teaches an apparatus comprising: an optically clear adhesive (OCA) layer 412 between the cover sheet 410 and a substrate 402; and the substrate, with drive or sense electrodes (404 and 406) of a touch sensor disposed on a first surface and a second surface of the substrate, the first surface being opposite the second surface (col. 9, lines 35-45), the drive or sense electrodes being made of a conductive mesh of conductive material comprising metal ( fig 4 and col. 2, lines 49-50).

**Regarding claim 4**, Hotelling teaches an apparatus wherein the conductive material is copper (col. 1, lines 57-58).

**Regarding claims 9 and 18**, Hotelling teaches an apparatus wherein the sense electrodes 404 being disposed on the first surface (top surface) of the substrate 402 and the drive electrodes 406 being disposed on the second surface (bottom surface) of the substrate (fig 4).

### ***Claim Rejections - 35 USC § 103***

The following is a quotation of pre-AIA 35 U.S.C. 103(a) which forms the basis for all obviousness rejections set forth in this Office action:

(a) A patent may not be obtained though the invention is not identically disclosed or described as set forth in section 102 of this title, if the differences between the subject matter sought to be patented and the prior art are such that the subject matter as a whole would have been obvious at the time the invention was made to a person having ordinary skill in the art to which said subject matter pertains. Patentability shall not be negated by the manner in which the invention was made.

Claims 2, 3, 11, 12, 20 are rejected under pre-AIA 35 U.S.C. 103(a) as being unpatentable over Hotelling (US 2008/0158183) in view of Bick (US 6,924,789).

**Regarding claims 2, 11 and 20**, Hotelling teaches an apparatus further comprising a display 410 separated from the second surface of the substrate 402 by an adhesive layer 412 (fig 4). Hotelling does not teach the display being separated by a dielectric layer. However, Bick teaches a display 4 separated from the second surface of the substrate 20 by dielectric layer (17, 27) (Bick fig 3, col. 2, lines 38-50). It would have been obvious to one having ordinary skill in the art at the time the invention was made to utilize the teachings of Bick in the touch panel of Hotelling to provide a dielectric barrier between the substrate and the display screen.

**Regarding claims 3 and 12**, Hotelling as modified by Bick teaches an apparatus wherein the dielectric layer comprises an OCA 27 and cover sheet layer 17 (Bick fig 3 and col. 2, lines 61-65).

Claims 5-8 and 14-17 are rejected under pre-AIA 35 U.S.C. 103(a) as being unpatentable over Hotelling, as applied to claims 1 and 10 above, and further in view of Frey (US 2009/0219257).

**Regarding claims 5 and 14**, Hotelling does not teach the mesh segments having a width of approximately 10 micrometers. However, Frey teaches mesh segments (fig 11) having a width of approximately less than 6 micrometers (paragraph 6). It would have been obvious to one having ordinary skill in the art at the time the invention was made to utilize the teachings of Frey in the touch panel of Hotelling to reduce the size of the touch panel.

**Regarding claims 6 and 15**, Hotelling as modified by Frey teaches an apparatus which one or more mesh segments or conductive micropattern covering approximately 5% of an active area or regions of the touch sensor (Frey paragraph 74).

**Regarding claims 7 and 16**, Hotelling as modified by Frey teaches an apparatus wherein each of the mesh segments is substantially sinusoidal (Frey, fig 23 and paragraph 158).

**Regarding claims 8 and 17**, Hotelling as modified by Frey teaches an apparatus wherein the conductive meshes have an optical transmissivity of approximately 90% (Frey, paragraph 8).

### ***Conclusion***

Any inquiry concerning this communication or earlier communications from the examiner should be directed to AHMED SAEED whose telephone number is (571)270-7976. The examiner can normally be reached on M-F (7:30-5:00pm).

If attempts to reach the examiner by telephone are unsuccessful, the examiner's supervisor, Renee Luebke can be reached on 571-272-2009.

The fax phone number for the organization where this application or proceeding is assigned is 571-273-8300.

Information regarding the status of an application may be obtained from the Patent Application Information Retrieval (PAIR) system. Status information for published applications may be obtained from either Private PAIR or Public PAIR. Status information for unpublished applications is available through Private PAIR only.

Art Unit: 2833

For more information about the PAIR system, see <http://pair-direct.uspto.gov>. Should you have questions on access to the Private PAIR system, contact the Electronic Business Center (EBC) at 866-217-9197 (toll-free). If you would like assistance from a USPTO Customer Service Representative or access to the automated information system, call 800-786-9199 (IN USA OR CANADA) or 571-272-1000.

/AHMED SAEED/  
Examiner, Art Unit 2833

*/renee luebke/*  
Renee Luebke  
Supervisory Patent Examiner  
AU 2833

<b>Notice of References Cited</b>	Application/Control No. 13/312,405	Applicant(s)/Patent Under Reexamination GUARD ET AL.	
	Examiner AHMED SAEED	Art Unit 2833	Page 1 of 1

**U.S. PATENT DOCUMENTS**

*	Document Number Country Code-Number-Kind Code	Date MM-YYYY	Name	Classification
*	A US-2008/0158183	07-2008	Hotelling et al.	345/173
*	B US-2009/0219257	09-2009	FREY et al.	345/173
*	C US-6,924,789	08-2005	Bick, Andrew Raymond	345/168
	D US-			
	E US-			
	F US-			
	G US-			
	H US-			
	I US-			
	J US-			
	K US-			
	L US-			
	M US-			

**FOREIGN PATENT DOCUMENTS**

*	Document Number Country Code-Number-Kind Code	Date MM-YYYY	Country	Name	Classification
	N				
	O				
	P				
	Q				
	R				
	S				
	T				

**NON-PATENT DOCUMENTS**

*	Document Number Country Code-Number-Kind Code	Date MM-YYYY	Country	Name	Classification
	Include as applicable: Author, Title Date, Publisher, Edition or Volume, Pertinent Pages)				
	U				
	V				
	W				
	X				

\*A copy of this reference is not being furnished with this Office action. (See MPEP § 707.05(a).)  
Dates in MM-YYYY format are publication dates. Classifications may be US or foreign.

<b>Search Notes</b>  	<b>Application/Control No.</b>  13312405	<b>Applicant(s)/Patent Under Reexamination</b>  GUARD ET AL.
	<b>Examiner</b>  AHMED SAEED	<b>Art Unit</b>  2833

CPC- SEARCHED		
Symbol	Date	Examiner

CPC COMBINATION SETS - SEARCHED		
Symbol	Date	Examiner

US CLASSIFICATION SEARCHED			
Class	Subclass	Date	Examiner

SEARCH NOTES		
Search Notes	Date	Examiner
Inventor name search	7/8/2013	AS
consulted with Renee Luebke	7/8/2013	AS
EAST text search with subclasses (200/512, 345/173)	7/8/2013	AS

INTERFERENCE SEARCH			
US Class/ CPC Symbol	US Subclass / CPC Group	Date	Examiner

--	--

PTO/SB/08  <b>INFORMATION DISCLOSURE STATEMENT BY APPLICANT</b>	<b>Application Number:</b> Unassigned		<b>First Named Inventor:</b> David Brent Guard	
	<b>Attorney Docket No:</b> 080900.1371	<b>Art Unit:</b> Unassigned	<b>Filing Date:</b> Herewith	

**ISSUED U.S. PATENTS AND PUBLISHED U.S. APPLICATIONS**

	DOCUMENT NUMBER	PUBLICATION OR ISSUE DATE	FIRST NAMED INVENTOR
A	7,663,607	02-16-2010	Hotelling
B	7,920,129	04-05-2011	Hotelling
C	8,031,094	10-04-2011	Hotelling
D	8,031,174	10-04-2011	Hamblin
E	8,049,732	11-01-2011	Hotelling

**UNPUBLISHED U.S. APPLICATIONS**

	DOCUMENT NUMBER	FILING DATE	FIRST NAMED INVENTOR
F			
G			
H			
I			

**FOREIGN PATENT DOCUMENTS**

	DOCUMENT NUMBER	PUBLICATION OR ISSUE DATE	COUNTRY	TRANSLATION (YES OR NO)
J				
K				

**NON-PATENT LITERATURE (NPL)**

	DOCUMENT (Including Author, Title, Source, and Pertinent Pages)	DATE
L		
M		
N		
O		
P		
Q		

EXAMINER <i>/Ahmed Saeed/</i>	DATE CONSIDERED 07/08/2013
EXAMINER: Initial if citation considered, whether or not citation is in conformance with MPEP § 609. Draw line through citation if not in conformance and not considered. Include copy of this form with next communication to the applicant.	

U.S. PATENT AND TRADEMARK OFFICE

PAL01:115530.1



PTO/SB/08  <b>INFORMATION DISCLOSURE STATEMENT BY APPLICANT</b>	<b>Application Number:</b> 13/312405	<b>First Named Inventor:</b> David Brent Guard	
	<b>Attorney Docket No:</b> 080900.1371	<b>Art Unit:</b> 2833	<b>Filing Date:</b> 12-06-2011

**ISSUED U.S. PATENTS AND PUBLISHED U.S. APPLICATIONS**

	<b>DOCUMENT NUMBER</b>	<b>PUBLICATION OR ISSUE DATE</b>	<b>FIRST NAMED INVENTOR</b>
A	7,875,814	25 January 2011	Chen
B	8,040,326	18 October 2011	Hotelling
C	8,179,381	15 May 2012	Frey
D	2009/0315854	24 December 2009	Matsuo
E	2012/0242588	27 September 2012	Myers
F	2012/0242592	27 September 2012	Rothkopf
G	2012/0243151	27 September 2012	Lynch
H	2012/0243719	27 September 2012	Franklin

**UNPUBLISHED U.S. APPLICATIONS**

	<b>DOCUMENT NUMBER</b>	<b>FILING DATE</b>	<b>FIRST NAMED INVENTOR</b>
I	61/454936	21 March 2011	Myers
J	61/454950	21 March 2011	Lynch
K	61/454894	21 March 2011	Rothkopf

**FOREIGN PATENT DOCUMENTS**

	<b>DOCUMENT NUMBER</b>	<b>PUBLICATION OR ISSUE DATE</b>	<b>COUNTRY</b>	<b>TRANSLATION (YES OR NO)</b>
L	WO 2012/129247	27 September 2012	PCT	
M				

**NON-PATENT LITERATURE (NPL)**

	<b>DOCUMENT (Including Author, Title, Source, and Pertinent Pages)</b>	<b>DATE</b>
N		
O		
P		
Q		
R		

<b>EXAMINER</b>  /Ahmed Saeed/	<b>DATE CONSIDERED</b>  07/08/2013
--------------------------------------	--

EXAMINER: Initial if citation considered, whether or not citation is in conformance with MPEP § 609. Draw line through citation if not in conformance and not considered. Include copy of this form with next communication to the applicant.

U.S. PATENT AND TRADEMARK OFFICE

PTO/SB/08  <b>INFORMATION DISCLOSURE STATEMENT BY APPLICANT</b>	<b>Application Number:</b> 13/312405	<b>First Named Inventor:</b> David Brent Guard	
	<b>Attorney Docket No:</b> 080900.1371	<b>Art Unit:</b> 2833	<b>Filing Date:</b> 12-06-2011

**ISSUED U.S. PATENTS AND PUBLISHED U.S. APPLICATIONS**

	<b>DOCUMENT NUMBER</b>	<b>PUBLICATION OR ISSUE DATE</b>	<b>FIRST NAMED INVENTOR</b>
A	2013/0076612	28 March 2013	Myers
B			
C			
D			
E			
F			
G			
H			
I			
J			
K			
L			
M			
N			

**UNPUBLISHED U.S. APPLICATIONS**

	<b>DOCUMENT NUMBER</b>	<b>FILING DATE</b>	<b>FIRST NAMED INVENTOR</b>
O			
P			
Q			

**FOREIGN PATENT DOCUMENTS**

	<b>DOCUMENT NUMBER</b>	<b>PUBLICATION OR ISSUE DATE</b>	<b>COUNTRY</b>	<b>TRANSLATION (YES OR NO)</b>
R				
S				

**NON-PATENT LITERATURE (NPL)**

	<b>DOCUMENT (Including Author, Title, Source, and Pertinent Pages)</b>	<b>DATE</b>
T		
U		

<b>EXAMINER</b> /Ahmed Saeed/	<b>DATE CONSIDERED</b> 07/08/2013
----------------------------------	--------------------------------------

EXAMINER: Initial if citation considered, whether or not citation is in conformance with MPEP § 609. Draw line through citation if not in conformance and not considered. Include copy of this form with next communication to the applicant.

U.S. PATENT AND TRADEMARK OFFICE

## EAST Search History

## EAST Search History (Prior Art)

Ref #	Hits	Search Query	DBs	Default Operator	Plurals	Time Stamp
L2	222	(optical or clear or transparent) adhesive layer and (display or screen) and substrate and (cover or case)	US-PGPUB; USPAT; USOCR; FPRS; EPO; JPO; DERWENT; IBM_TDB	ADJ	ON	2013/07/08 10:44
L3	29	(optical or clear or transparent) adhesive layer and (display or screen) and substrate and (cover or case) and dielectric (layer or sheet)	US-PGPUB; USPAT; USOCR; FPRS; EPO; JPO; DERWENT; IBM_TDB	ADJ	ON	2013/07/08 10:45
L5	3235	345/174.ccls.	US-PGPUB; USPAT; USOCR; FPRS; EPO; JPO; DERWENT; IBM_TDB	ADJ	ON	2013/07/08 11:22
L6	14517	345/173.ccls.	US-PGPUB; USPAT; USOCR; FPRS; EPO; JPO; DERWENT; IBM_TDB	ADJ	ON	2013/07/08 11:23
L7	3624	345/173.ccls. and (micromillimeter or m)	US-PGPUB; USPAT; USOCR; FPRS; EPO; JPO; DERWENT; IBM_TDB	ADJ	ON	2013/07/08 11:25
L8	0	first (surface or face) near substrate and electrode and adhes\$3 and second (surface or face) near substrate and micromillimeter	US-PGPUB; USPAT; USOCR; FPRS; EPO; JPO; DERWENT; IBM_TDB	ADJ	ON	2013/07/08 11:25
L9	216	first (surface or face) near substrate and electrode and adhes\$3 and second (surface or face) near substrate and micrometer	US-PGPUB; USPAT; USOCR; FPRS; EPO; JPO; DERWENT; IBM_TDB	ADJ	ON	2013/07/08 11:29
L10	2	2009/0153507	US-PGPUB;	ADJ	ON	2013/07/08

PETITIONERS

Exhibit 1003, Page 119

			USPAT; USOCR; FPRS; EPO; JPO; DERWENT; IBM_TDB			11:57
L12	140	345/173.ccls. and (micromillimeter or m) and sinusoidal	US-PGPUB; USPAT; USOCR; FPRS; EPO; JPO; DERWENT; IBM_TDB	ADJ	ON	2013/07/08 12:10
L13	0	2011/0310033	US-PGPUB; USPAT; USOCR; FPRS; EPO; JPO; DERWENT; IBM_TDB	ADJ	ON	2013/07/08 14:25
L14	2	"20110310033"	US-PGPUB; USPAT; USOCR; FPRS; EPO; JPO; DERWENT; IBM_TDB	ADJ	ON	2013/07/08 14:25
L15	41	("7920129"   "20120242588"   "8040326"   "20020167619"   "20060097991"   "7663607"   "8031174"   "8049732"   "20100302201"   "20090315854"   "20110310037"   "20100045632"   "20120242592"   "20120243151"   "8179381"   "20130076612"   "8031094"   "20110310033"   "20120243719"   "7875814"   "20110007020").PN.	US-PGPUB; USPAT; USOCR; FPRS; EPO; JPO; DERWENT; IBM_TDB	ADJ	ON	2013/07/08 14:30
L16	16	("20090315854"   "20120242588"   "20120242592"   "20120243151"   "20120243719"   "7875814"   "8040326"   "8179381").PN.	US-PGPUB; USPAT; USOCR; FPRS; EPO; JPO; DERWENT; IBM_TDB	ADJ	ON	2013/07/08 14:42
L17	0	345/173.ccls. and conductive mesh and 5 (percent or 5%)	US-PGPUB; USPAT; USOCR; FPRS; EPO; JPO; DERWENT; IBM_TDB	ADJ	ON	2013/07/08 15:09
L18	10	345/173.ccls. and conductive mesh and (5 percent or 5%)	US-PGPUB; USPAT; USOCR; FPRS; EPO; JPO; DERWENT; IBM_TDB	ADJ	ON	2013/07/08 15:09
L19	1091	200/512.ccls.	US-PGPUB; USPAT; USOCR;	ADJ	ON	2013/07/08 17:11

PETITIONERS

Exhibit 1003, Page 120

			FPRS; EPO; JPO; DERWENT; IBM_TDB			
S19	1309	atmel corporation.as.	US-PGPUB; USPAT; USOCR; FPRS; EPO; JPO; DERWENT; IBM_TDB	ADJ	ON	2013/07/03 13:36
S20	24	atmel corporation.as. and adhes\$3 (layer or sheet)	US-PGPUB; USPAT; USOCR; FPRS; EPO; JPO; DERWENT; IBM_TDB	ADJ	ON	2013/07/03 13:36
S22	10146	first (surface or face) same substrate and electrode and adhes\$3	US-PGPUB; USPAT; USOCR; FPRS; EPO; JPO; DERWENT; IBM_TDB	ADJ	ON	2013/07/03 13:45
S23	3134	first (surface or face) near substrate and electrode and adhes\$3 and second (surface or face)	US-PGPUB; USPAT; USOCR; FPRS; EPO; JPO; DERWENT; IBM_TDB	ADJ	ON	2013/07/03 13:46
S24	1799	first (surface or face) near substrate and electrode and adhes\$3 and second (surface or face) near substrate	US-PGPUB; USPAT; USOCR; FPRS; EPO; JPO; DERWENT; IBM_TDB	ADJ	ON	2013/07/03 13:46
S25	69	first (surface or face) near substrate and electrode and second adhes\$3 and second (surface or face) near substrate	US-PGPUB; USPAT; USOCR; FPRS; EPO; JPO; DERWENT; IBM_TDB	ADJ	ON	2013/07/03 13:47
S35	705	(display or panel) near substrate with dielectric layer	US-PGPUB; USPAT; USOCR; FPRS; EPO; JPO; DERWENT; IBM_TDB	ADJ	ON	2013/07/03 17:31
S36	594	(display or panel) near substrate with dielectric layer and electrode	US-PGPUB; USPAT; USOCR; FPRS; EPO; JPO; DERWENT; IBM_TDB	ADJ	ON	2013/07/03 17:32

**EAST Search History (Interference)**

<This search history is empty>

**7/ 8/ 2013 5:23:38 PM**

**C:\Users\asaeed\Documents\EAST\Workspaces\13312405.wsp**

PTO/SB/08  <b>INFORMATION DISCLOSURE STATEMENT BY APPLICANT</b>	<b>Application Number:</b> 13/312405	<b>First Named Inventor:</b> David Brent Guard	
	<b>Attorney Docket No:</b> 080900.1371	<b>Art Unit:</b> 2833	<b>Filing Date:</b> 12-06-2011

**ISSUED U.S. PATENTS AND PUBLISHED U.S. APPLICATIONS**

	<b>DOCUMENT NUMBER</b>	<b>PUBLICATION OR ISSUE DATE</b>	<b>FIRST NAMED INVENTOR</b>
A	2013/0076612	28 March 2013	Myers
B			
C			
D			
E			
F			
G			
H			
I			
J			
K			
L			
M			
N			

**UNPUBLISHED U.S. APPLICATIONS**

	<b>DOCUMENT NUMBER</b>	<b>FILING DATE</b>	<b>FIRST NAMED INVENTOR</b>
O			
P			
Q			

**FOREIGN PATENT DOCUMENTS**

	<b>DOCUMENT NUMBER</b>	<b>PUBLICATION OR ISSUE DATE</b>	<b>COUNTRY</b>	<b>TRANSLATION (YES OR NO)</b>
R				
S				

**NON-PATENT LITERATURE (NPL)**

	<b>DOCUMENT (Including Author, Title, Source, and Pertinent Pages)</b>	<b>DATE</b>
T		
U		

<b>EXAMINER</b>	<b>DATE CONSIDERED</b>
EXAMINER: Initial if citation considered, whether or not citation is in conformance with MPEP § 609. Draw line through citation if not in conformance and not considered. Include copy of this form with next communication to the applicant.	

## Electronic Acknowledgement Receipt

<b>EFS ID:</b>	15587577
<b>Application Number:</b>	13312405
<b>International Application Number:</b>	
<b>Confirmation Number:</b>	6025
<b>Title of Invention:</b>	Two-Layer Sensor Stack
<b>First Named Inventor/Applicant Name:</b>	David Brent Guard
<b>Customer Number:</b>	12323
<b>Filer:</b>	Russell Clayton Gee/Paula Hurley
<b>Filer Authorized By:</b>	Russell Clayton Gee
<b>Attorney Docket Number:</b>	080900.1371
<b>Receipt Date:</b>	23-APR-2013
<b>Filing Date:</b>	06-DEC-2011
<b>Time Stamp:</b>	12:22:11
<b>Application Type:</b>	Utility under 35 USC 111(a)

### Payment information:

Submitted with Payment	no
------------------------	----

### File Listing:

Document Number	Document Description	File Name	File Size(Bytes)/ Message Digest	Multi Part /.zip	Pages (if appl.)
1	Transmittal Letter	IDS_080900_1371.pdf	64765 <small>91ff694d2f8ede27dbc90c20e28c47f92e3e23f9</small>	no	1

### Warnings:

### Information:

PETITIONERS



2	Information Disclosure Statement (IDS) Form (SB08)	SB08_080900_1371.pdf	75068	no	1
			cd208501d60d569e1e07fce9ecbe77109fad905a		

**Warnings:**

**Information:**

This is not an USPTO supplied IDS fillable form

<b>Total Files Size (in bytes):</b>	139833
-------------------------------------	--------

**This Acknowledgement Receipt evidences receipt on the noted date by the USPTO of the indicated documents, characterized by the applicant, and including page counts, where applicable. It serves as evidence of receipt similar to a Post Card, as described in MPEP 503.**

**New Applications Under 35 U.S.C. 111**

**If a new application is being filed and the application includes the necessary components for a filing date (see 37 CFR 1.53(b)-(d) and MPEP 506), a Filing Receipt (37 CFR 1.54) will be issued in due course and the date shown on this Acknowledgement Receipt will establish the filing date of the application.**

**National Stage of an International Application under 35 U.S.C. 371**

**If a timely submission to enter the national stage of an international application is compliant with the conditions of 35 U.S.C. 371 and other applicable requirements a Form PCT/DO/EO/903 indicating acceptance of the application as a national stage submission under 35 U.S.C. 371 will be issued in addition to the Filing Receipt, in due course.**

**New International Application Filed with the USPTO as a Receiving Office**

**If a new international application is being filed and the international application includes the necessary components for an international filing date (see PCT Article 11 and MPEP 1810), a Notification of the International Application Number and of the International Filing Date (Form PCT/RO/105) will be issued in due course, subject to prescriptions concerning national security, and the date shown on this Acknowledgement Receipt will establish the international filing date of the application.**

IN THE UNITED STATES PATENT AND TRADEMARK OFFICE

First Named Inventor: David Brent Guard  
Application No.: 13/312405  
Filing Date: 6 December 2011  
Art Unit: 2833  
Confirmation No.: 6025  
Title: Two-Layer Sensor Stack

**Information Disclosure Statement**

Applicant submits this Information Disclosure Statement (IDS) under 37 C.F.R. § 1.97(b)(3). Applicant respectfully requests the Examiner to consider and cite in the examination of this Application the documents listed in the attached Form PTO/SB/08. Under 37 C.F.R. § 1.98(a)(2)(ii), Applicant has not provided copies of U.S. patents or U.S. patent application publications.

Under 37 C.F.R. § 1.97(g), the filing of this IDS shall not be construed as a representation that a search has been made. Moreover, under 37 C.F.R. § 1.97(h), the filing of this IDS shall not be construed to be an admission that the information cited in this IDS is or is considered to be material to patentability as defined by 37 C.F.R. §1.56(b). Furthermore, the filing of this IDS shall not be construed to be an admission that any information cited in this IDS is or is considered to be prior art under 35 U.S.C. §§ 102-103.

The Commissioner may charge any fee due and credit any overpayment in this Patent Application to Deposit Account No. 02-0384 of Baker Botts L.L.P.

Respectfully submitted,  
BAKER BOTTS L.L.P.  
Attorneys for Applicant

/Russell C. Gee/

Russell C. Gee  
Reg. No. 62,178

Date: 23 April 2013

PTO/SB/08  <b>INFORMATION DISCLOSURE STATEMENT BY APPLICANT</b>	<b>Application Number:</b> 13/312405	<b>First Named Inventor:</b> David Brent Guard	
	<b>Attorney Docket No:</b> 080900.1371	<b>Art Unit:</b> 2833	<b>Filing Date:</b> 12-06-2011

**ISSUED U.S. PATENTS AND PUBLISHED U.S. APPLICATIONS**

	<b>DOCUMENT NUMBER</b>	<b>PUBLICATION OR ISSUE DATE</b>	<b>FIRST NAMED INVENTOR</b>
A	7,875,814	25 January 2011	Chen
B	8,040,326	18 October 2011	Hotelling
C	8,179,381	15 May 2012	Frey
D	2009/0315854	24 December 2009	Matsuo
E	2012/0242588	27 September 2012	Myers
F	2012/0242592	27 September 2012	Rothkopf
G	2012/0243151	27 September 2012	Lynch
H	2012/0243719	27 September 2012	Franklin

**UNPUBLISHED U.S. APPLICATIONS**

	<b>DOCUMENT NUMBER</b>	<b>FILING DATE</b>	<b>FIRST NAMED INVENTOR</b>
I	61/454936	21 March 2011	Myers
J	61/454950	21 March 2011	Lynch
K	61/454894	21 March 2011	Rothkopf

**FOREIGN PATENT DOCUMENTS**

	<b>DOCUMENT NUMBER</b>	<b>PUBLICATION OR ISSUE DATE</b>	<b>COUNTRY</b>	<b>TRANSLATION (YES OR NO)</b>
L	WO 2012/129247	27 September 2012	PCT	
M				

**NON-PATENT LITERATURE (NPL)**

	<b>DOCUMENT (Including Author, Title, Source, and Pertinent Pages)</b>	<b>DATE</b>
N		
O		
P		
Q		
R		

<b>EXAMINER</b>	<b>DATE CONSIDERED</b>
EXAMINER: Initial if citation considered, whether or not citation is in conformance with MPEP § 609. Draw line through citation if not in conformance and not considered. Include copy of this form with next communication to the applicant.	



- (51) International Patent Classification:  
*H04M 1/02* (2006.01)      *G06F 1/16* (2006.01)
- (21) International Application Number:  
PCT/US2012/029844
- (22) International Filing Date:  
20 March 2012 (20.03.2012)
- (25) Filing Language:  
English
- (26) Publication Language:  
English
- (30) Priority Data:  
61/454,950      21 March 2011 (21.03.2011)      US  
61/454,894      21 March 2011 (21.03.2011)      US  
61/454,936      21 March 2011 (21.03.2011)      US  
13/108,256      16 May 2011 (16.05.2011)      US  
13/171,295      28 June 2011 (28.06.2011)      US  
13/184,303      15 July 2011 (15.07.2011)      US  
13/422,724      16 March 2012 (16.03.2012)      US
- (71) Applicant (for all designated States except US): **APPLE INC.** [US/US]; 1 Infinite Loop, M/S 36-2PAT, Cupertino, CA 95014 (US).

- (72) Inventors; and
- (75) Inventors/Applicants (for US only): **ROTHKOPF, Fletcher, R.** [US/US]; 5 Infinite Loop, M/S 305-1PH, Cupertino, CA 95014 (US). **MYERS, Scott, A.** [US/US]; 5 Infinite Loop, MS 305-1PH, Cupertino, CA 95014 (US). **LYNCH, Stephen, Brian** [US/US]; 1 Infinite Loop, M/S 305-1DR, Cupertino, CA 95014 (US). **RAPPOFORT, Benjamin, M.** [US/US]; 1 Infinite Loop, M/S 305-2PD, Cupertino, CA 95014 (US). **FRANKLIN, Jermey, C.** [US/US]; 1 Infinite Loop, M/S 305-2PD, Cupertino, CA 95014 (US).
- (74) Agent: **TREYZ, G., Victor**; TREYZ LAW GROUP, 870 Market Street, Suite 984, San Francisco, CA 94102 (US).
- (81) Designated States (unless otherwise indicated, for every kind of national protection available): AE, AG, AL, AM, AO, AT, AU, AZ, BA, BB, BG, BH, BR, BW, BY, BZ, CA, CH, CL, CN, CO, CR, CU, CZ, DE, DK, DM, DO, DZ, EC, EE, EG, ES, FI, GB, GD, GE, GH, GM, GT, HN, HR, HU, ID, IL, IN, IS, JP, KE, KG, KM, KN, KP, KR, KZ, LA, LC, LK, LR, LS, LT, LU, LY, MA, MD, ME, MG, MK, MN, MW, MX, MY, MZ, NA, NG, NI, NO, NZ,

[Continued on next page]

(54) Title: ELECTRONIC DEVICES WITH FLEXIBLE DISPLAYS

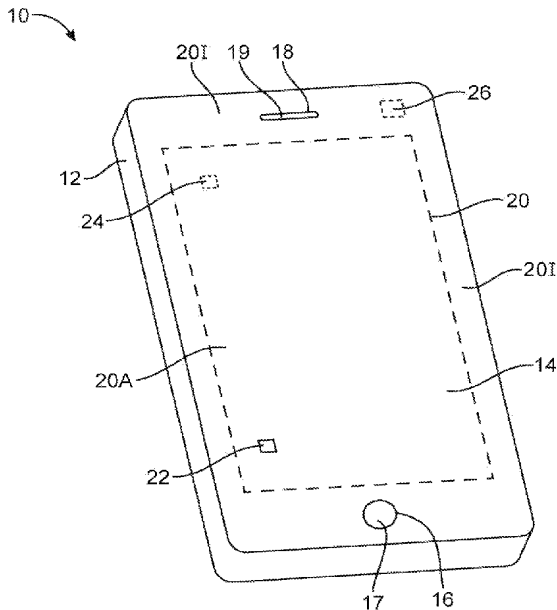

FIG. 1

(57) Abstract: Electronic devices may be provided that contain flexible displays and internal components. An internal component may be positioned under the flexible display. The internal component may be an output device such as a speaker that transmits sound through the flexible display or an actuator that deforms the display in a way that is sensed by a user. The internal component may also be a microphone or pressure sensor that receives sound or pressure information through the flexible display. Structural components may be used to permanently or temporarily deform the flexible display to provide tactile feedback to a user of the device. Electronic devices may be provided with concave displays or convex displays formed from one or more flexible layers including a flexible display layer. Portions of the flexible display may be used as speaker membranes for display-based speaker structures.



WO 2012/129247 A2



OM, PE, PG, PH, PL, PT, QA, RO, RS, RU, RW, SC, SD, SE, SG, SK, SL, SM, ST, SV, SY, TH, TJ, TM, TN, TR, TT, TZ, UA, UG, US, UZ, VC, VN, ZA, ZM, ZW.

DE, DK, EE, ES, FI, FR, GB, GR, HR, HU, IE, IS, IT, LT, LU, LV, MC, MK, MT, NL, NO, PL, PT, RO, RS, SE, SI, SK, SM, TR), OAPI (BF, BJ, CF, CG, CI, CM, GA, GN, GQ, GW, ML, MR, NE, SN, TD, TG).

**(84) Designated States** (*unless otherwise indicated, for every kind of regional protection available*): ARIPO (BW, GH, GM, KE, LR, LS, MW, MZ, NA, RW, SD, SL, SZ, TZ, UG, ZM, ZW), Eurasian (AM, AZ, BY, KG, KZ, MD, RU, TJ, TM), European (AL, AT, BE, BG, CH, CY, CZ,

**Published:**

— *without international search report and to be republished upon receipt of that report (Rule 48.2(g))*

## Electronic Devices With Flexible Displays

This application claims priority to United States patent application No. 13/171,295, filed June 28, 2011, United States patent application No. 13/108,256, filed May 16, 2011, United States patent application No. 13/184,303, filed July 15, 2011, United States patent application No. 13/422,724, filed March 16, 2012, provisional patent application No. 61/454,894, filed March 21, 2011, provisional patent application No. 61/454,936, filed, March 21, 2011, and provisional patent application No. 61/454,950, filed March 21, 2011 which are hereby incorporated by reference herein in their entirety.

Background

This relates generally to flexible displays, and more particularly, to electronic devices with flexible displays.

Electronic devices such as portable computers  
5 and cellular telephones are often provided with rigid  
displays made from rigid display structures. For example,  
a liquid crystal display (LCD) may be formed from a stack  
of rigid display structures such as a thin-film transistor  
layer with display pixels for providing visual feedback to  
10 a user, a color filter layer for providing the display

pixels with color, a touch screen panel for gathering touch input from a user, and a cover glass layer for protecting the display and internal components.

Conventional devices may also have input-output components such as buttons, microphones, speakers, and other components. Openings are commonly formed in the housing of a conventional device to accommodate operation of these input-output components. For example, openings may be formed in a device housing to accommodate speaker and microphone ports and openings may be formed in a display cover glass layer to accommodate a speaker port and menu button.

The inclusion of these openings to accommodate input-output components may not be desirable. For example, the presence of openings may be aesthetically unappealing, may raise the risk of damage from environmental exposure, and may reduce the amount of active display area that is available to display images for a user.

There is often very little real estate available for mounting these input-output components. For example, input-output components are often mounted under an inactive portion of a display or within the sidewalls of an electronic device housing.

The size and number of input-output components such as speakers may be limited by the amount of space available in these locations. For example, a conventional device may have a single speaker mounted under an inactive portion of a display. The size and quality of such a speaker may be limited by a lack of space in the inactive portion of the display. Additionally, mounting a speaker in the inactive portion of a display may add undesirable width to the inactive portion of the display.

Devices with planar cover glass layers may be prone

to scratches and damage when dropped on a surface. Users can minimize scratches and damage from drop events using a protective case. Protective cases may not, however, be convenient or aesthetically appealing for many users.

5           It is often desirable to produce portable devices of minimal size. Users of portable electronic devices may find a thinner device more desirable than a thicker device. Compact portable devices are sometimes provided with convex housing shapes. A convex housing  
10 shape may increase the internal volume of a device while preserving a sleek, thin look that is aesthetically pleasing to a user.

A portable compact device with a convex housing may have a display. In conventional arrangements, the  
15 display is flat, so only the portions of the device other than the display have a convex shape. This may limit the internal volume of the device and may detract from its appearance.

It would therefore be desirable to be able to  
20 provide improved electronic devices.

#### Summary

Electronic devices may be provided with flexible displays. The flexible displays may be composed of one or  
25 more flexible layers and may be mounted on top of or under a cover layer. For example, a flexible display may be mounted on top of a rigid support member or may be mounted on the underside of a rigid cover layer.

Electronic devices may also be provided with  
30 user interface components (input-output components) such as buttons, microphones, speakers, piezoelectric actuators (for receiving electrical input from a user or tactile feedback to users), or other actuators such as vibrators, pressure sensors, and other components. These components



may be mounted under portions of a flexible display.

During operation of the electronic device, the flexibility of the display may allow a user to interact with the component through the display. For example, 5 sound waves from a speaker or localized vibrations from an actuator in an electronic device may pass through the flexible display. The flexible display may also allow an internal microphone, pressure sensor, or force sensor (or other internal components) to receive external input. For 10 example, a user may deflect a flexible display using a finger or other external object, barometric pressure may be monitored through the flexible display, or sound waves may be received through the flexible display.

Components may receive input or may supply 15 output through a physically deformed portion of the flexible display (e.g., a deformation that occurs when a user presses on the display to compress the component). In some configurations, a portion of the flexible display may serve as a membrane that forms part of a microphone, 20 speaker, pressure sensor, or other electronic component.

The ability of a user to compress a component such as a button switch by deforming the flexible display may allow the area of a device available for visual display to be enlarged. For example, the active area of a 25 flexible display may overlap a component such as a button or speaker.

If desired, a flexible display may be deformed by an internal component to provide audio or tactile feedback to a user. For example, structures inside an 30 electronic device may be pressed against portions of a flexible display to temporarily create an outline for a virtual on-screen button or to temporarily create a grid of ridges that serve to delineate the locations of keys in a keyboard (keypad).

Electronic devices may be provided with concave displays. Peripheral edge portions of a concave display may be raised relative to depressed central portions of the concave display. This helps reduce scratches and other damage due to contact with the central portion of the display.

Concave displays may include one or more flexible display layers and may be mounted on top of or under a cover layer. For example, a flexible display layer may be mounted on top of a rigid support member or may be mounted on the underside of a rigid cover layer

Concave displays may also include touch-sensitive capabilities by stacking a touch sensor array layer on top of or under flexible display layers. Rigid concave displays may be formed from a flexible display layer, a touch-sensitive layer, and a rigid cover layer or rigid support structure.

Devices having concave displays formed from curved flexible display layers may help maximize the use of the internal volume of an electronic device.

Electronic devices may be provided with convex displays. The convex displays may include one or more flexible display layers and may be mounted on top of or under a cover layer with a curved shape. For example, a flexible display layer may be mounted on top of a rigid support member having a convex surface or may be mounted on the concave underside of a rigid convex display cover layer.

Convex displays may be provided with touch-sensitive capabilities by stacking a touch sensor array on top of or under flexible display layers. Rigid convex displays may be formed from a flexible display layer, a touch-sensitive layer, and a rigid cover layer or support structure.

Devices having convex displays formed from curved flexible display layers may help maximize the use of the internal volume of an electronic device.

5 A display cover such as a cover glass layer may be mounted over a flexible display. The flexible display may be an organic light-emitting diode display having a flexible substrate formed from one or more sheets of polymer. The flexible display may include a touch sensor layer having an array of capacitive touch sensor  
10 electrodes.

There may be one or more display-based speaker structures in the electronic device. The display-based speaker structures may be mounted under the flexible display. Portions of the flexible display may be used as  
15 speaker membranes for the display-based speaker structures.

The flexible display may have an active area that is configured to display images to a user. Speaker membranes may be formed from the active portion of the  
20 flexible display. The display-based speaker structures may be driven by transducers that receive an electrical audio signal input from circuitry in the electronic device. Piezoelectric transducers or transducers formed from coils and magnets may be used to drive the display-  
25 based speaker structures.

A stiffening structure may be used to stiffen a portion of a flexible display that is used as a speaker membrane. The stiffening structure may be formed from a layer of foam interposed between sheets of stiffening  
30 material. The stiffening structure may form a stiff and lightweight support structure that allows the speaker membrane to respond accurately to the transducer.

A suspension structure may be used to attach a display-based speaker structure to surrounding housing

structures. The suspension structure may form a pliant interface between the speaker structure and the surrounding housing structures. The suspension structure may allow the speaker structure to vibrate during speaker operation while inhibiting lateral motion of the speaker structure.

Speaker structures may be configured to achieve a desired frequency response. The electronic device housing in which a speaker structure is mounted may be provided with an acoustic port to tune speaker frequency response. The type of transducer that is used in a speaker may be selected to tune speaker frequency response. The size and placement of internal device components that affect speaker volume and speaker mass may also be selected to tune speaker frequency response.

An electronic device may be provided with an array of display-based speaker structures. The speaker membrane for each speaker structure may be stiffened with an associated stiffening structure. Each stiffened speaker membrane may be surrounded by a ring of flexible display that is configured to absorb lateral vibrations and thus prevent interference between neighboring speakers.

Further features of the invention, its nature and various advantages will be more apparent from the accompanying drawings and the following detailed description of the preferred embodiments.

#### Brief Description of the Drawings

FIG. 1 is a perspective view of an illustrative electronic device with a flexible display and internal components in accordance with an embodiment of the present invention.

FIG. 2 is a diagram of an illustrative set of

display layers that may be used to form a flexible display in accordance with an embodiment of the present invention.

FIG. 3 is a cross-sectional side view of a portion of an illustrative electronic device in the vicinity of an internal user interface component in accordance with an embodiment of the present invention.

FIG. 4 is a cross-sectional side view of a portion of an illustrative electronic device in the vicinity of a button in accordance with an embodiment of the present invention.

FIG. 5 is a cross-sectional side view of another embodiment of a portion of an illustrative electronic device in the vicinity of a button in accordance with an embodiment of the present invention.

FIG. 6 is a cross-sectional side view of a portion of an illustrative electronic device in the vicinity of an audio component in accordance with an embodiment of the present invention.

FIG. 7 is a cross-sectional side view of another embodiment of a portion of an illustrative electronic device in the vicinity of an audio component in accordance with an embodiment of the present invention.

FIG. 8 is a cross-sectional side view of yet another embodiment of a portion of an illustrative electronic device in the vicinity of an audio component in accordance with an embodiment of the present invention.

FIG. 9 is a cross-sectional side view of a portion of an illustrative electronic device in the vicinity of an actuator such as a piezoelectric actuator in accordance with an embodiment of the present invention.

FIG. 10 is a cross-sectional side view of a portion of an illustrative electronic device in the vicinity of an internal structural component in accordance with an embodiment of the present invention.

FIG. 11 is a cross-sectional side view of a portion of an illustrative electronic device in the vicinity of a combined internal interface component in accordance with an embodiment of the present invention.

5 FIG. 12 is a perspective view of a portion of an illustrative electronic device with a flexible display and a combined internal interface component in accordance with an embodiment of the present invention.

10 FIG. 13 is a perspective view of a portion of an illustrative electronic device with a flexible display and a combined internal interface component mounted to actuator stage in accordance with an embodiment of the present invention.

15 FIG. 14 is a cross-sectional side view of a portion of an illustrative electronic device in the vicinity of an internal structural component mounted to an actuator stage in accordance with an embodiment of the present invention.

20 FIG. 15 is a cross-sectional side view of a portion of an illustrative electronic device with a cover and an internal structural component mounted to an actuator in accordance with an embodiment of the present invention.

25 FIG. 16 is a cross-sectional side view of a portion of an illustrative electronic device in the vicinity of a pressure sensor in accordance with an embodiment of the present invention.

30 FIG. 17 is a perspective view of an illustrative electronic device with a concave display and a bezel in accordance with an embodiment of the present invention.

FIG. 18 is a cross-sectional side view of an illustrative electronic device having a concave display with a flexible display layer that conforms to the concave shape of a support structure in accordance with an

embodiment of the present invention.

FIG. 19 is a cross-sectional side view of a portion of an illustrative electronic device having a cover layer and a flexible display layer joined by an adhesive layer in accordance with an embodiment of the present invention.

FIG. 20 is a cross-sectional side view of a portion of an illustrative electronic device having a flexible display layer, a flexible touch-sensitive layer, and a cover layer joined by adhesive layers in accordance with an embodiment of the present invention.

FIG. 21 is a cross-sectional side view of an illustrative electronic device having a concave display with a radius of curvature chosen to protect the device from a drop surface in accordance with an embodiment of the present invention.

FIG. 22 is a perspective view of an illustrative electronic device with a convex display and a bezel formed from a housing structure in accordance with an embodiment of the present invention.

FIG. 23 is a cross-sectional side view of an illustrative electronic device with a convex display and internal components in accordance with an embodiment of the present invention.

FIG. 24 is a cross-sectional side view of a portion of an illustrative electronic device having a convex display with a flexible display layer that conforms to a support structure in accordance with an embodiment of the present invention.

FIG. 25 is a cross-sectional side view of a portion of an illustrative electronic device having a convex cover layer and a flexible display layer joined by an adhesive layer in accordance with an embodiment of the present invention.

FIG. 26 is a cross-sectional side view of a portion of an illustrative electronic device having a flexible display layer, a touch-sensitive layer and a convex cover layer joined by adhesive layers in accordance with an embodiment of the present invention.

FIG. 27 is a cross-sectional perspective view of an illustrative electronic device having a convex display and a connector port arranged to use the internal volume of the device in accordance with an embodiment of the present invention.

FIG. 28 is a cross-sectional perspective view of an illustrative electronic device having a convex display and internal components in accordance with an embodiment of the present invention.

FIG. 29 is a cross-sectional side view of an illustrative electronic device substantially surrounded by a convex display in accordance with an embodiment of the present invention.

FIG. 30 is a diagram of an illustrative electronic device such as a portable computer having a display and one or more speaker structures in accordance with an embodiment of the present invention.

FIG. 31 is a diagram of an illustrative electronic device such as a cellular telephone or other handheld device having a display and one or more speaker structures in accordance with an embodiment of the present invention.

FIG. 32 is a diagram of an illustrative electronic device such as a tablet computer having a display and one or more speaker structures in accordance with an embodiment of the present invention.

FIG. 33 is a diagram of an illustrative electronic device such as a computer monitor with a built-in computer having a display and one or more speaker



structures in accordance with an embodiment of the present invention.

FIG. 34 is a diagram of an illustrative set of display layers that may be used to form a flexible display in accordance with an embodiment of the present invention.

FIG. 35 is a diagram of an illustrative set of layers that may be used to form an organic light-emitting diode display in accordance with an embodiment of the present invention.

FIG. 36 is a cross-sectional side view of a portion of an illustrative electronic device in which a flexible display forms part of a speaker structure in accordance with an embodiment of the present invention.

FIG. 37 is a cross-sectional side view of a portion of an illustrative electronic device in which a flexible display forms part of a speaker structure in accordance with an embodiment of the present invention.

FIG. 38 is a cross-sectional side view of a portion of an illustrative electronic device in which a flexible display forms part of a speaker structure in accordance with an embodiment of the present invention.

FIG. 39 is a perspective view of an illustrative electronic device of the type shown in FIG. 38 having a cover layer with speaker openings in accordance with an embodiment of the present invention.

FIG. 40 is a cross-sectional side view of a portion of an illustrative electronic device in which a flexible display is stiffened with a support structure in accordance with an embodiment of the present invention.

FIG. 41 is a cross-sectional side view of a portion of an illustrative electronic device having a curved flexible display with a curved support structure in accordance with an embodiment of the present invention.

FIG. 42 is a cross-sectional side view of a

portion of an illustrative electronic device in which a flexible display forms part of a single speaker structure in accordance with an embodiment of the present invention.

FIG. 43 is a cross-sectional side view of a  
5 portion of an illustrative electronic device in which a flexible display forms part of an array of speaker structures in accordance with an embodiment of the present invention.

FIG. 44 is a bottom view of an illustrative  
10 electronic device of the type shown in FIG. 43 having a flexible display that forms part of an array of speaker structures in accordance with an embodiment of the present invention.

15 Detailed Description

Electronic devices may be provided with flexible displays. A flexible display may include one or more flexible layers. If desired, the flexible display may include a display cover layer such as a flexible or rigid  
20 display cover layer.

In some configurations, an electronic device may be provided with a flexible display and user interface components that are positioned behind, abutted against or integrated into the flexible display. FIGS. 1-16 show  
25 examples of configurations in which user interface components may be positioned behind, abutted against or integrated into the flexible display.

In some configurations, an electronic device may be provided with a concave display having one or more  
30 flexible display layers. FIGS. 1, 2, and 17-21 show examples of configurations in which an electronic device may be provided with a concave display having one or more flexible display layers.

In some configurations, an electronic device may

be provided with a convex display having one or more flexible display layers. FIGS. 1, 2, and 22-29 show examples of configurations in which an electronic device may be provided with a convex display having one or more  
5 flexible display layers.

In some configurations, a portion of the flexible display may form a membrane structure of an electronic component such as a speaker, a microphone, a laser microphone or a pressure sensor. FIGS. 30-44 show  
10 examples of configurations in which a portion of the flexible display may form a membrane structure of an electronic component.

As shown in the examples of FIGS. 1-16, an electronic device may be provided with a flexible display and user interface components. User interface components may include buttons, switches, microphones, actuators such as solenoids, motors, and piezoelectric actuators, connector ports, touch screens, proximity sensors and other components for accepting input from, or transmitting  
15 information to, a user or the surrounding environment.  
20

Flexible displays may be formed from flexible layers such as a flexible display layer (e.g., a flexible organic light-emitting diode array), a flexible touch-sensitive layer (e.g., a sheet of polymer with an array of transparent capacitor electrodes for a capacitive touch  
25 sensor), a flexible substrate layer, etc. These flexible layers may, if desired, be covered by a flexible or rigid cover layer (sometimes referred to as a cover glass) or may be supported by a support structure (e.g., a rigid  
30 support structure on the underside of the flexible layers). In electronic devices with flexible displays that are covered by rigid cover layers, the cover layers may be provided with openings that provide access to the flexible layers of the display in the vicinity of a user

interface device. For example, a cover glass layer may have an opening that allows a button member to move relative to the cover glass layer. As the button member moves within the opening, underlying portions of the flexible display may be deformed (e.g., to allow actuation of an associated switch).

To maximize the area of the portion of the flexible display that is available for displaying visual information to the user, user interface components may be positioned behind, abutted against or integrated into the flexible display. The deformable nature of the flexible display may allow a user to interact with the user interface components (input-output components) by moving the display into contact with the user interface components or by otherwise allowing the display to locally flex (e.g., to allow sound to pass through the flexible display or to allow a barometric pressure measurements of the exterior environment to be made by an internal pressure sensor). If desired, a portion of the flexible display may form a membrane portion of an electrical component. Components that may be provided with a membrane that is formed from a portion of a flexible display include microphones, laser microphones, pressure sensors, speakers, etc.

An illustrative electronic device of the type that may be provided with a flexible display is shown in FIG. 1.

Electronic device 10 may be a portable electronic device or other suitable electronic device. For example, electronic device 10 may be a laptop computer, a tablet computer, a somewhat smaller device such as a wrist-watch device, pendant device, or other wearable or miniature device, a cellular telephone, a media player, etc.

Device 10 may include a housing such as housing

12. Housing 12, which may sometimes be referred to as a case, may be formed of plastic, glass, ceramics, fiber composites, metal (e.g., stainless steel, aluminum, etc.), other suitable materials, or a combination of these materials. In some situations, parts of housing 12 may be formed from dielectric or other low-conductivity material. In other situations, housing 12 or at least some of the structures that make up housing 12 may be formed from metal elements.

Device 10 may have a flexible display such as flexible display 14. Flexible display 14 may be formed from multiple layers of material. These layers may include a touch sensor layer such as a layer on which a pattern of indium tin oxide (ITO) electrodes or other suitable transparent electrodes have been deposited to form a capacitive touch sensor array. These layers may also include a layer that contains an array of display pixels. The touch sensor layer and the display layer may be formed using flexible sheets of polymer or other substrates having thicknesses of 10 microns to 0.5 mm or other suitable thicknesses (as an example).

The display pixel array may be, for example, an organic light-emitting diode (OLED) array. Other types of flexible display pixel arrays may also be formed (e.g., electronic ink displays, etc.). The use of OLED technology to form flexible display 14 is sometimes described herein as an example. This is, however, merely illustrative. Flexible display 14 may be formed using any suitable flexible display technology. The use of flexible displays that are based on OLED technology is merely illustrative.

In addition to these functional display layers (i.e., the OLED array and the optional touch sensor array), display 14 may include one or more structural

layers. For example, display 14 may be covered with a flexible or rigid cover layer and/or may be mounted on a support structure (e.g., a rigid support). Layers of adhesive may be used in attaching flexible display layers to each other and may be used in mounting flexible display layers to rigid and flexible structural layers.

In configurations for display 14 in which the cover layer for display 14 is flexible, input-output components that rely on the presence of flexible layers may be mounted at any suitable location under the display (e.g., along peripheral portions of the display, in a central portion of the display, etc.). In configurations for display 14 in which the flexible layers are covered by a rigid cover glass layer or other rigid cover layer, the rigid layer may be provided with one or more openings and the electronic components may be mounted under the openings. For example, a rigid cover layer may have openings such as a circular opening 16 for button 17 and a speaker port opening such as speaker port opening 18 (e.g., for an ear speaker for a user). Device 10 may also have other openings (e.g., openings in display 14 and/or housing 12 for accommodating volume buttons, ringer buttons, sleep buttons, and other buttons, openings for an audio jack, data port connectors, removable media slots, etc.).

In some embodiments, portions of flexible display 14 such as peripheral regions 20I may be inactive and portions of display 14 such as rectangular central portion 20A (bounded by dashed line 20) may correspond to the active part of display 14. In active display region 20A, an array of image pixels may be used to present text and images to a user of device 10. In active region 20A, display 14 may include touch sensitive components for input and interaction with a user of device 10. If

desired, regions such as regions 20I and 20A in FIG. 1 may both be provided with display pixels (i.e., all or substantially all of the entire front planar surface of a device such as device 10 may be covered with display pixels).

Device 10 may, if desired, have internal user interface components such as buttons 17 or speaker component 19 that occupy openings such as openings 16 and 18 respectively in an optional rigid cover layer of flexible display 14. Buttons 17 may be based on dome switches or other switch circuitry. Buttons 17 may include button members that form push buttons (e.g., momentary buttons), slider switches, rocker switches, etc. Device 10 may include internal structural components such as structural component 22 that add a raised structure to a portion of flexible display 14. Device 10 may include components such as interface components 24 and 26 that may be fully internal to device 10, but that receive input from the user or from the surrounding environment through physical interaction with flexible display 14. Interface components 22, 24, and 26 may be positioned in active region 20A or inactive region 20I of flexible display 14. Interface components 22, 24, and 26 may be positioned separately from one another or may be commonly located to form a combined component with structural and internal features. Interface components 24 and 26 may be positioned underneath flexible display 14 so that flexible display 14 must be deformed in order to contact components 24 or 26 or, if desired may be positioned to remain in constant contact with flexible display 14.

An exploded perspective view of an illustrative display is shown in FIG. 2. As shown in FIG. 2, flexible display 14 may be formed by stacking multiple layers including flexible display layer 14A, touch-sensitive

layer 14B, and cover layer 14C. Flexible display 14 may also include other layers of material such as adhesive layers, optical films, or other suitable layers. Flexible display layer 14 may include image pixels formed from  
5 light-emitting diodes (LEDs), organic LEDs (OLEDs), plasma cells, electronic ink elements, liquid crystal display (LCD) components, or other suitable image pixel structures compatible with flexible displays.

Touch-sensitive layer 14B may incorporate  
10 capacitive touch electrodes such as horizontal transparent electrodes 32 and vertical transparent electrodes 34. Touch-sensitive layer 14B may, in general, be configured to detect the location of one or more touches or near touches on touch-sensitive layer 14B based on capacitive,  
15 resistive, optical, acoustic, inductive, or mechanical measurements, or any phenomena that can be measured with respect to the occurrences of the one or more touches or near touches in proximity to touch sensitive layer 14B.

Software and/or hardware may be used to process  
20 the measurements of the detected touches to identify and track one or more gestures. A gesture may correspond to stationary or non-stationary, single or multiple, touches or near touches on touch-sensitive layer 14B. A gesture may be performed by moving one or more fingers or other  
25 objects in a particular manner on touch-sensitive layer 14B such as tapping, pressing, rocking, scrubbing, twisting, changing orientation, pressing with varying pressure and the like at essentially the same time, contiguously, or consecutively. A gesture may be  
30 characterized by, but is not limited to a pinching, sliding, swiping, rotating, flexing, dragging, or tapping motion between or with any other finger or fingers. A single gesture may be performed with one or more hands, by one or more users, or any combination thereof.



Cover layer 14C may be formed from plastic or glass (sometimes referred to as display cover glass) and may be flexible or rigid. If desired, the interior surface of peripheral inactive portions 20I of cover layer 14C may be provided with an opaque masking layer on such as black ink.

Touch-sensitive flexible display section 14AB may be formed from display pixel array layer 14A and optional touch sensor layer 14B.

FIG. 3 is a cross-sectional side view of a portion of flexible display 14 in the vicinity of internal user interface component 24. Flexible display 14 may be deformed away from its natural shape under pressure. For example, flexible display 14 may be deflected by pressure exerted by a user or by other external forces in direction 40. As shown in FIG. 3, pressure in direction 40 may cause flexible display 40 to deform as indicated by dashed lines 44. Internal component 24 may be configured to receive input due to deformation of flexible display 14. Internal component 24 may also provide a temporary return (restoring) pressure in direction 42.

Pressure in direction 42 may cause flexible display 14 to temporarily deform outward of device 10 as indicated by dashed lines 46. Pressure in direction 42 may, if desired, be formed by an internal actuator that deforms display 14 to provide a desired tactile sensation on the surface of display 14 to a user of device 10. Flexible display 14 may have a natural resiliency that, following deformation as indicated by dashed lines 44, causes flexible display to temporarily deform outward of device 10 as indicated by dashed lines 46 before returning to its natural shape. Internal component 24 may be a button, an actuator such as a motor, solenoid, vibrator, or piezoelectric actuator, a pressure sensor, an audio

component such as a microphone or speaker, or other component. Because display 14 is flexible, these components may operate effectively, even when covered by display 14. For example, audio components such as

5 microphones and speakers may receive and transmit sound through flexible display 14. A barometric pressure sensor or a force sensor may also receive input through flexible display 14. Components such as actuators may be used to temporarily create raised ridges or other external

10 features on the surface of the flexible display (e.g., to indicate to a user where an on-screen button or group of buttons is located). The portion of display 14 under which components 24 are mounted may be active (i.e., a portion of the display that contains OLED pixels or other

15 display pixels) or inactive (i.e., a peripheral portion of the display outside of the active region).

FIG. 4 is a cross-sectional side view of a portion of device 10 in the vicinity of button 17 of device 10. As shown in FIG. 4, button 17 may have a

20 button member such as button member 52 that reciprocates within opening 16 of cover layer 14C. When a user presses the exterior of button member 52 in direction 58, button member 52 may press against touch-sensitive flexible display section (layer) 14AB. Touch-sensitive flexible

25 display section 14AB may be deformed to depress a dome switch such as dome switch 56 or other switch mechanism, thereby activating the switch (e.g., shorting internal switch terminals together to close the switch). Dome switches such as dome switch 56 may, if desired, be

30 mounted to printed circuits such as printed circuit 54. Dome switch 56 may have a dome-shaped biasing member that pushes touch-sensitive flexible display section 14AB outward in direction 60 when the user releases pressure from button member 52. Dome switch 54 and printed circuit

54 may be recessed in a support structure such as support structure 50 behind flexible display 14. Other types of switches may be used if desired, such as switches with spring-based biasing members or other biasing structures that bias button members such as button member 52. The use of a dome switch with a dome-shaped biasing structure is merely illustrative.

FIG. 5 is a cross-sectional side view of a portion of device 10 in the vicinity of button 17 of device 10. The illustrative embodiment of FIG. 5 differs from the illustrative embodiment of FIG. 4 in that cover layer 14C of flexible display 14 is not a rigid cover layer, but a flexible cover layer. In an embodiment in which flexible display 14 contains a flexible cover layer 14C, button 17 includes dome switch 56 and printed circuit 54. In the embodiment of FIG. 5, a user may press the exterior of flexible display 14 in direction 58. Flexible display 14 may be deformed to depress dome switch 56 or other switch mechanism, thereby activating the switch. As in FIG. 4, dome switches such as dome switch 56 may, if desired, be mounted to printed circuits such as printed circuit 54. Dome switch 56 may have a dome-shaped biasing member that pushes flexible display 14 outward in direction 60 when the user releases pressure from button member 52. Dome switch 54 and printed circuit 54 may be mounted in support structures 50 behind flexible display 14. Other types of switches may use spring-based biasing members or other biasing structures to bias button members such as button member 52. The use of a dome switch with a dome-shaped biasing structure is merely illustrative.

Providing device 10 with flexible display 14 without the need for an opening in flexible display 14 to access button 17 allows flexible display 14 to extend over button 17 without disruption. In both the FIG. 4 and FIG.

5 configurations, the portion of the flexible display that overlaps the button may be an active display portion or an inactive display portion. When an active display portion is configured so as to overlap buttons and other  
5 components, there is generally more area available for the active display portion. The presence of flexible display 14 over button 17 (or other components) may also reduce the risk of moisture or dirt entering into the interior of device 10.

10 FIG. 6 is a cross-sectional side view of a portion of device 10 in the vicinity of audio component 19. Audio component 19 may be recessed in a chassis 50 behind flexible display 14. Audio component 19 may be a speaker for providing sound to a user of device 10 or a  
15 microphone for receiving input from a user or the external environment. In the embodiment shown in FIG. 6, sound may be transmitted through flexible display 14 to a microphone or from a speaker. The portion of flexible display 14 that overlaps audio component 19 may be active or  
20 inactive. Arrangements in which component 19 is covered with part of the active area of display 14 may allow the size of active region 20A of flexible display 14 to be increased. The presence of flexible display 14 over audio component 19 may also reduce the risk of moisture or dirt  
25 entering into the interior of device 10.

FIG. 7 is a cross-sectional side view of a portion of device 10 in the vicinity of another embodiment of audio component 19. In the illustrative embodiment of FIG. 7, audio component 19 may be a speaker or microphone  
30 that contains a diaphragm such as diaphragm 70. Diaphragm 70 may be formed from a separate structure that is attached to the underside of flexible display 14 or may be formed from a part of flexible display 14. As in the embodiment shown in FIG. 6, audio component 19 may be

mounted within support structures 50. Audio component 19 may include a magnet such as magnet 74 and a coil such as coil 72 in which current may flow. If audio component 19 is a speaker, current may be driven through coil 72 to induce motion in diaphragm 70 and thereby emit sound through flexible display 14. If audio component 19 is a microphone, sound waves originating from the exterior of device 10 may induce vibrations in flexible display 14 which are transmitted to diaphragm 70 and ultimately to coil 72 in which current may be induced. The current produced in coil 72 may be used to transmit sound information to device 10. Diaphragm 70 may be a separate member in contact with flexible display 14 or may be an integral part of flexible display 14.

FIG. 8 is a cross-sectional side view of a portion of device 10 in the vicinity of another possible embodiment of audio component 19. As shown in FIG. 8, audio component 19 may be a laser microphone which uses vibrations in flexible display 14 induced by sound originating external to device 10 to produce a signal to be transmitted to device 10. As shown in FIG. 8, audio component 19 may be recessed in support structures 50. Audio component 19 may include a light emitting component such as laser component 80. Laser component 80 may emit a laser beam such as laser beam 84 in the direction of flexible display 14. Laser beam 84 may reflect off of flexible display 14 and a reflected laser beam such as reflected laser beam 86 may be absorbed by a laser absorbing component 82.

Laser beam 84 and reflected laser beam 86 may be used in combination with laser 80 and photosensitive element 82 to monitor variations in distance 88 from flexible display 14 to component 80 and component 82. Sound waves originating external to device 10 may induce

vibrations in flexible display 14 causing distance 88 to oscillate. The oscillations in distance 88 may be converted into sound-related information by device 10.

FIG. 9 is a cross-sectional side view of a portion of device 10 in the vicinity of a component such as component 22 of FIG. 1. In the embodiment shown in FIG. 9, component 22 may contain an actuator such as a piezoelectric (actuator 90). Piezoelectric actuators such as piezoelectric actuator 90 may vary in shape (e.g., thickness) in response to applied control voltages and may produce an output voltage when compressed (i.e., the piezoelectric element in actuator 90 may serve as a force sensor in addition to serving as a controllable actuator). A user of device 10 may exert force on flexible display 14 in direction 92. Flexible display 14 may be deformed to exert a mechanical pressure on piezoelectric element 90 or other force sensor, inducing a voltage which may be transmitted to device 10. Conversely, piezoelectric actuator 90 may be used to provide tactile feedback to a user of device 10. A voltage difference applied to the surfaces of piezoelectric actuator 90 may induce an expansion of piezoelectric actuator 90. Piezoelectric actuator 90 may then deform flexible display 90 in direction 94 providing tactile feedback to a user of device 10.

FIG. 10 is a cross-sectional side view of a portion of device 10 in the vicinity of structural component 22 of device 10. Structural component 22 may cause a permanent deformation such as deformation 102 in flexible display 14 to indicate the location of portion 101 of touch-sensitive layer 14B in display 14 to the user of device 10. Portion 101 may be, for example, a letter key or other button in a virtual keypad (keyboard) displayed on flexible display 14. A touch sensor array

associated with display 14 may be used to gather user input (i.e., the touch sensor array may be used to determine when a user has pressed the virtual key associated with portion 101). The location of portion 101 may also be indicated visually using associated display pixels in flexible display 14. At times, a user may desire to be able to locate portion 101 without having to look at flexible display 14. Deforming flexible display 14 in the vicinity of portion 101 using structural component 22 may allow a user to locate portion 101 without visual aid. Structural component 22 may be an isolated component indicating the location of a single portion 101 of touch-sensitive layer 14B or may be one of an array of components 22 indicating the locations of an array of portions 101 (e.g., the array of letter, number, and symbol keys in a virtual keypad displayed on display 14). Structural component 10 may be a separate component mounted to support structures 50 or may be an integral part of support structures 50.

FIG. 11 is a cross-sectional side view of a portion of device 10 in the vicinity of a hybrid component such as component 100. Component 100 may include both an internal interface component such as internal component 24 and a structural component such as structural component 22. Structural component 22 may cause a permanent deformation such as deformation 102 in flexible display 14 in the vicinity of internal component 24 to indicate the location of internal component 22 to the user of device 10. The presence of flexible display 14 between the user of device 10 and internal component 24 may obscure the location of internal interface component 24. The location of interface component 24 may be indicated visually using display pixels in flexible display 14. The deformation of flexible display 14 in the vicinity of interface component

24 using structural component 22 may also allow the user to locate interface component 24 without visual aid. Component 100 may be an isolated component indicating the location of a single interface component 24 of touch-sensitive layer 14B or may be one of an array of components 100 indicating the locations of an array of interface components 24.

FIG. 12 is a perspective view of an embodiment of device 10 in which internal component 24 is a button such as button 17. In the embodiment of FIG. 12, as in FIG. 11, component 100 includes internal component 24 and structural component 22 (shown in FIG. 11). As shown in FIG. 12, a ridge or other deformation such as deformation 102 in flexible display 14 may be used to indicate the location of button 17.

FIG. 13 is a cross-sectional side view of a portion of device 10 in the vicinity of another illustrative embodiment of a hybrid component such as component 100 which includes an internal interface component such as internal component 24 and a structural component such as structural component 22 mounted to an actuator such as actuator stage 110. Component 100 may be recessed in chassis 50. Actuator stage 110 may be electrically or mechanically raised in direction 112 to temporarily produce deformations such as deformations 102 in flexible display 14. Deformations 102 in flexible display 14 may indicate the location of internal interface device 24 to a user of device 10. Actuator stage 110 may be electrically or mechanically lowered in direction 114 to remove deformations 102 in flexible display 14 returning flexible display 14 to its original shape. Component 100 may be an isolated component indicating the location of a single interface component 24 of touch-sensitive layer 14B or may be one of an array of



components 100 indicating the locations of an array of respective interface components 24.

FIG. 14 is a cross-sectional side view of a portion of device 10 in the vicinity of another illustrative embodiment of a component such as structural component 22. In the arrangement of FIG. 14, structural component 22 is mounted an actuator such as actuator stage 110. Some modes of operating device 10 may require visual interaction with a user of device 10 (e.g., a mode involving the display of images or video). In these visual modes, the location of portion 101 of touch-sensitive layer 14B of flexible display 14 may be indicated visually using display pixels in flexible display 14.

In other modes of operation of device 10, a user of device 10 may wish to determine the location of portion 101 without visual aid. In the embodiment shown in FIG. 14, component 22 may be recessed in support structures 50. Actuator stage 110 may be electrically or mechanically raised in direction 112 to move structural component 22 into contact with flexible display 14 to temporarily produce deformations such as deformations 102 in flexible display 14. Deformations 102 may indicate the location of portion 101 to a user of device 10. When no longer needed for tactile interaction (e.g., upon switching to a video display mode), actuator 110 may be electrically or mechanically moved in direction 114 to lower structural component 22 and remove deformations 102 in flexible display 14.

FIG. 15 is a cross-sectional side view of an embodiment of device 10 in which device 10 includes housing 12 and cover member 122. Cover member 122 may be formed of plastic, glass, ceramics, fiber composites, metal (e.g., stainless steel, aluminum, etc.), other

suitable materials, or a combination of these materials. Cover member 122 may be a single structure or may include multiple cover structures. In order to facilitate lifting of cover 122 by a user of device 10, structural component 22 may be coupled to an actuator 130 which may be used to lift structural component 122 in direction 134. When lifted, structural component 134 may cause a deformation such as deformation 102 in flexible display 14. Flexible display 14 may exert a pressure on cover member 122, lifting cover member 122 in direction 134 allowing the user to grip cover member 122 in order to lift cover member 122 to an open position such as open position 140. Actuator 130 may then be used to lower structural component 22 in direction 132 in order to allow flexible display 14 to return to its original shape. Actuator 130 may be activated in response to a control signal produced by the user using actuator switch 124 or by a control signal from other suitable control circuitry.

FIG. 16 is a cross-sectional side view of a portion of device 10 in the vicinity of another illustrative embodiment of internal interface component 24. In the embodiment shown in FIG. 16, interface component 24 may be a pressure sensor that includes a pressure sensing module 140. Pressure sensing module 140 may be coupled between a contact member such as contact member 142 (which is in contact with flexible display 14) and electrical contacts 144. Pressure may be exerted on flexible display 14 (e.g., by a user of device 10 or due to atmospheric pressure changes in the surrounding environment of device 10). Pressure exerted on flexible display 14 may be transmitted to pressure sensing module 140 by contact member 142. Pressure information may be transmitted to device 10 through electrical contacts 144. Pressure sensing module 140 may sense pressure changes

using piezoelectric, capacitive, inductive, resistive, optical or other mechanisms. Providing device 10 with flexible display 14 allows flexible display 14 to extend over interface component 24, increasing the area of active region 20A of flexible display 14. The presence of flexible display 14 over interface component 24 may also reduce the risk of moisture or dirt entering into the interior of device 10.

In accordance with an embodiment, an electronic device is provided that includes a flexible display and an internal component, where the flexible display may be deformed by an action external to the device and deformation of the flexible display creates a response from the internal component.

In accordance with another embodiment, the flexible display includes a flexible display layer and a touch-sensitive layer.

In accordance with another embodiment, the flexible display layer of the flexible display includes an active display region and the internal component is covered with a portion of the active display region of the flexible display.

In accordance with another embodiment, the internal component includes a button and deformation of the flexible display compresses the button.

In accordance with another embodiment, the flexible display further includes a rigid cover layer having at least one opening.

In accordance with another embodiment, the opening includes a hole in the rigid cover layer, the button further includes a button member in the opening, the button member moves within the hole in the rigid cover layer, and the movement of the button member in the opening causes deformation of the flexible display.

In accordance with another embodiment, the internal component includes a pressure sensor and deformation of the flexible display exerts a mechanical pressure on the pressure sensor.

5 In accordance with another embodiment, the pressure sensor includes a piezoelectric actuator and the mechanical pressure induces a voltage on the piezoelectric actuator.

10 In accordance with another embodiment, the internal component includes a laser microphone for detecting a sound originating external to the electronic device and detecting the sound includes, with a laser, detecting deformation of the flexible display.

15 In accordance with an embodiment, an electronic device is provided that includes a flexible display and an audio component that transmits or receives sound through the flexible display.

20 In accordance with another embodiment, the flexible display includes an active display region and the audio component is mounted behind the active display region of the flexible display.

In accordance with another embodiment, the flexible display includes a flexible display layer and a touch-sensitive layer.

25 In accordance with another embodiment, the audio component includes a diaphragm and the diaphragm is mounted in contact with the flexible display.

30 In accordance with another embodiment, an electronic device is provided that includes a housing, a flexible display mounted on the housing, and a first internal component mounted under a portion of the flexible display, where the first internal component is configured to deform the portion of the flexible display.

In accordance with another embodiment, the first

internal component includes a piezoelectric actuator, where a voltage applied to the piezoelectric actuator causes an expansion of the piezoelectric actuator and the portion of the flexible display deforms in response to the expansion of the piezoelectric actuator.

In accordance with another embodiment, the first internal component includes a structural component, where the portion of the flexible display deforms in response to physical contact with the structural component and deformation of the portion of the flexible display causes the portion of the flexible display to conform to a surface of the structural component.

In accordance with another embodiment, the electronic device further includes a second internal component mounted under the portion of the flexible display, where the portion of the flexible display that conforms to the surface of the structural component indicates the location of the second internal component.

In accordance with another embodiment, the second internal component includes a button, where the portion of the flexible display is configured to be further deformed by an action external to the electronic device and further deformation of the portion of the flexible display compresses the button.

In accordance with another embodiment, the first internal component further includes an actuator, where the structural component is mounted on the actuator, where raising the actuator moves the structural component into contact with the portion of the flexible display, and where lowering the actuator moves the structural component out of contact with the flexible display.

In accordance with another embodiment, the flexible display includes a touch-sensitive layer, where deformation of the portion of the flexible display

conforming to the surface of the structural component indicates the location of a portion of the touch-sensitive layer of the flexible display.

5 In accordance with another embodiment, the electronic device further includes a second internal component mounted on the actuator and deformation of the portion of the flexible display conforming to the surface of the structural component indicates the location of the second internal component.

10 In accordance with another embodiment, the electronic device further includes a cover member and an actuator switch coupled to the actuator, where deformation of the flexible display exerts a pressure on the cover member and the pressure on the cover member lifts the  
15 cover member.

The foregoing is merely illustrative of the principles of this invention and various modifications can be made by those skilled in the art without departing from the scope and spirit of the invention.

20 As shown in the examples of FIGS. 1, 2 and 17-21, an electronic device may be provided with a concave display. The concave display may include a flexible display layer that has been bent to curve the display.

Concave displays may be formed from flexible  
25 layers such as a flexible display layer (e.g., a flexible organic light-emitting diode array), a flexible touch-sensitive layer (e.g., a sheet of polymer with an array of transparent capacitor electrodes for a capacitive touch sensor), a flexible substrate layer, etc. These flexible  
30 layers may, if desired, be covered by a flexible or rigid cover layer (sometimes referred to as a cover glass) or may be supported by a support structure (e.g., a rigid support structure on the underside of the flexible layers). In electronic devices with concave displays that

are covered by rigid cover layers, the cover layers may be provided with openings that provide access to the flexible layers of the display. For example, a cover glass layer may have an opening that allows a button member to move relative to the cover glass layer. As the button member moves within the opening, underlying portions of the flexible display may be deformed (e.g., to allow actuation of an associated switch).

Electronic devices may also be provided with user interface components (input-output components) such as buttons, microphones, speakers, piezoelectric actuators or (for receiving electrical input from a user or tactile feedback to users), other actuators such as vibrators, pressure sensors, and other components. These components may be mounted under portions of a flexible display.

User interface components may be mounted under the flexible display or may be integrated into the flexible display. The deformable nature of the flexible display may allow a user to interact with the user interface components (input-output components) by moving the display into contact with the user interface components or by otherwise allowing the display to locally flex (e.g., to allow sound to pass through the flexible display or to allow barometric pressure measurements of the exterior environment to be made by an internal pressure sensor). If desired, a portion of the flexible display may form a membrane portion of an electrical component. Components that may be provided with a membrane that is formed from a portion of a flexible display include microphones, laser microphones, pressure sensors, speakers, etc.

Concave displays formed from flexible and rigid layers that all have concave shapes (i.e., displays formed from a collection of layers in which no layer of the

display is planar) may provide reduced vulnerability to damage during a drop event in which an electronic device strikes the ground or other external objects while maximizing the internal volume of the device that is  
5 available to hold electrical and mechanical device components.

An illustrative electronic device of the type that may be provided with a concave display is shown in FIG. 1. Electronic device 10 may be a portable electronic  
10 device or other suitable electronic device. For example, electronic device 10 may be a laptop computer, a tablet computer, a somewhat smaller device such as a wrist-watch device, pendant device, or other wearable or miniature device, a cellular telephone, a media player, etc.

15 Device 10 may include a housing such as housing 12. Housing 12, which may sometimes be referred to as a case, may be formed of plastic, glass, ceramics, fiber composites, metal (e.g., stainless steel, aluminum, etc.), other suitable materials, or a combination of these  
20 materials. In some situations, parts of housing 12 may be formed from dielectric or other low-conductivity material. In other situations, housing 12 or at least some of the structures that make up housing 12 may be formed from metal elements.

25 Device 10 may have a concave display such as concave display 14. Concave display 14 may be formed from multiple layers of material. These layers may include a touch sensor layer such as a layer on which a pattern of indium tin oxide (ITO) electrodes or other suitable  
30 transparent electrodes have been deposited to form a capacitive touch sensor array or a touch sensor layer formed using other touch technologies (e.g., resistive touch, acoustic touch, optical touch, etc.). These layers may also include a layer that contains an array of display



pixels. The touch sensor layer and the display layer may be formed using flexible sheets of polymer or other substrates having thicknesses of 10 microns to 0.5 mm or other suitable thicknesses (as an example).

5           The display pixel array may be, for example, an organic light-emitting diode (OLED) array containing rows and columns of OLED display pixels. Other types of flexible display pixel arrays may also be formed (e.g., electronic ink displays, etc.). The use of OLED  
10 technology to form flexible display 14 is sometimes described herein as an example. This is, however, merely illustrative. Flexible display 14 may be formed using any suitable flexible display technology. The use of flexible displays that are based on OLED technology is merely  
15 illustrative.

          In addition to these functional display layers (i.e., the OLED array and the optional touch sensor array), display 14 may include one or more structural layers. For example, display 14 may be covered with a  
20 flexible or rigid cover layer and/or may be mounted on a support structure (e.g., a rigid support). Layers of adhesive may be used in attaching flexible display layers to each other and may be used in mounting flexible display layers to rigid and flexible structural layers.

25           In configurations for display 14 in which the cover layer for display 14 is flexible, input-output components that rely on the presence of flexible layers may be mounted at any suitable location under the display (e.g., along peripheral portions of the display, in a  
30 central portion of the display, etc.). In configurations for display 14 in which the flexible layers are covered by a rigid cover glass layer or other rigid cover layer, the rigid layer may be provided with one or more openings and the electronic components may be mounted under the

openings. For example, a rigid cover layer may have openings such as a circular opening 16 for button 17 and a speaker port opening such as speaker port opening 18 (e.g., for an ear speaker for a user). Device 10 may also  
5 have other openings (e.g., openings in display 14 and/or housing 12 for accommodating volume buttons, ringer buttons, sleep buttons, and other buttons, openings for an audio jack, data port connectors, removable media slots, etc.).

10 In some embodiments, portions of concave display 14 such as peripheral regions 20I may be inactive and portions of display 14 such as rectangular central portion 20A (bounded by dashed line 20) may correspond to the active part of display 14. In active display region 20A,  
15 an array of image pixels may be used to present text and images to a user of device 10. In active region 20A, display 14 may include touch sensitive components for input and interaction with a user of device 10. If desired, regions such as regions 20I and 20A in FIG. 1 may  
20 both be provided with display pixels (i.e., all or substantially all of the entire front planar surface of a device such as device 10 may be covered with display pixels).

Device 10 may, if desired, have internal user  
25 interface components such as buttons 17 or speaker component 19 that occupy openings such as openings 16 and 18 respectively in an optional rigid cover layer of concave display 14. Buttons 17 may be based on dome switches or other switch circuitry. Buttons 17 may  
30 include button members that form push buttons (e.g., momentary buttons), slider switches, rocker switches, etc. Device 10 may include internal structural components such as structural component 22 that add a raised structure to a portion of concave display 14. Device 10 may include

components such as interface components 24 and 26 that may be fully internal to device 10, but that receive input from the user or from the surrounding environment through physical interaction with concave display 14. Interface components 22, 24, and 26 may be positioned in active region 20A or inactive region 20I of concave display 14. Interface components 22, 24, and 26 may be positioned separately from one another or may be commonly located to form a combined component with structural and internal features. Interface components 24 and 26 may be positioned underneath concave display 14 so that concave display 14 must be deformed in order to contact components 24 or 26 or, if desired may be positioned to remain in constant contact with concave display 14.

An exploded perspective view of an illustrative display is shown in FIG. 2. As shown in FIG. 2, concave display 14 may be formed by stacking multiple layers including flexible display layer 14A, touch-sensitive layer 14B, and cover layer 14C. Display 14 may also include other layers of material such as adhesive layers, optical films, or other suitable layers. Flexible display layer 14 may include image pixels formed from light-emitting diodes (LEDs), organic LEDs (OLEDs), plasma cells, electronic ink elements, liquid crystal display (LCD) components, or other suitable image pixel structures compatible with flexible displays.

Touch-sensitive layer 14B may incorporate capacitive touch electrodes such as horizontal transparent electrodes 32 and vertical transparent electrodes 34. Touch-sensitive layer 14B may, in general, be configured to detect the location of one or more touches or near touches on touch-sensitive layer 14B based on capacitive sensors, resistive sensors, optical sensors, acoustic sensors, inductive sensors, or force sensors.

Software and/or hardware may be used to process the measurements of the detected touches to identify and track one or more gestures. A gesture may correspond to stationary or non-stationary, single or multiple, touches or near touches on touch-sensitive layer 14B. A gesture may be performed by moving one or more fingers or other objects in a particular manner on touch-sensitive layer 14B such as tapping, pressing, rocking, scrubbing, twisting, changing orientation, pressing with varying pressure and the like at essentially the same time, contiguously, or consecutively. A gesture may be characterized by, but is not limited to a pinching, sliding, swiping, rotating, flexing, dragging, or tapping motion between or with any other finger or fingers. A single gesture may be performed with one or more hands, by one or more users, or any combination thereof.

Cover layer 14C may be formed from plastic or glass (sometimes referred to as display cover glass) and may be flexible or rigid. If desired, the interior surface of peripheral inactive portions 20I of cover layer 14C may be provided with an opaque masking layer on such as black ink.

Touch-sensitive flexible display section 14AB may be formed from display pixel array layer 14A and optional touch sensor layer 14B.

FIG. 17 is perspective view of an illustrative embodiment of device 10 with concave display 14 in which device 10 is provided with a bezel such as bezel 200 surrounding the periphery of concave display 14. In the illustrative embodiment shown in FIG. 17, housing 12 of device 10 has an opening 204 that may provide access to a data port. The surface of bezel 200 may be formed in-plane with the surface of display 14 (i.e., so that bezel 200 and display 14 form a single smooth surface) or may be

formed at a right angle to the walls of housing 12 (as examples). Bezel 200 may be a separate bezel member or may be formed as a portion of housing 12. As shown in FIG. 17, top and bottom portions 202 of bezel 200 may have a concave (curved) shape that matches the cross-sectional curved shape of concave display 14.

FIG. 18 is a cross-sectional side view of an illustrative embodiment of device 10 in which concave display 14 is formed by mounting flexible display layer 14A to a concave support structure such as support structure 210 (e.g., a rigid support structure having at least a concave external surface such as a metal, glass, or plastic support structure) using a layer of adhesive material such as adhesive layer 212. As shown in FIG. 18, the internal volume of device 10, defined by housing 12, bezel 202 and concave display 14 may include volume 216 above a plane (indicated by dashed line 214) defined by the deepest point in the curvature of display 14. This is because the inner surface of support structure 210 is convex (in the FIG. 18 example). Volume 216 provides space in addition to rectangular volume 218 in which internal components such as component 220 (e.g., printed circuit boards, antennas or other components) may be positioned. The ability to bend flexible display 14 into the concave shape of FIG. 18 may therefore help maximize the interior space that is available within device 10 to mount device components.

FIG. 19 is a cross-sectional side view of a portion of device 10. In the illustrative embodiment of FIG. 19, concave display 14 is formed from flexible display layer 14A, adhesive layer 212, and rigid cover layer 14C (e.g., a layer of rigid plastic or a layer of rigid cover glass having a concave external surface and a convex inner surface to which flexible display layer 14A

conforms). Concave display 14 may be formed adjacent to bezel portion 200 of housing 12 or may be joined to housing 12 by an additional mounting member. The concave shape of cover layer 14C of display 14 may provide reduced susceptibility to damage if device 10 is dropped. Forming flexible display layer 14A in a shape that matches the concave shape of cover layer 14C (i.e., so that layer 14A conforms to the convex inner surface of layer 14C) may provide additional internal volume 216 to device 10.

FIG. 20 is a cross-sectional side view of a portion of another embodiment of device 10. In the illustrative embodiment of FIG. 20, concave display 14 is formed from flexible display layer 14A attached to optional touch-sensitive layer 14B by adhesive layer 212. Touch-sensitive layer 14B may further be attached to rigid cover layer 14C (e.g., a glass or plastic layer) using adhesive layer 230 such that all layers (212, 14B, 230, and 14C) of display 14 conform to the concave shape of cover layer 14C. Concave display 14 may be directly adjacent to bezel portion 200 of housing 12 or may be joined to housing 212 by an additional mounting member. The concave shape of all layers (14A, 212, 14B, 230, and 14C) of display 14 may provide reduced susceptibility to damage in the event that device 10 is dropped and may provide additional internal volume 216.

FIG. 21 is a cross-sectional side view of device 10 and a common drop surface such as drop surface 240 (e.g., sidewalk concrete, asphalt, tile, or any other surface) on which device 10 may be dropped. Drop surface 240 may have a surface roughness due to surface features such as surface features 242. Surface features 242 may have a characteristic height such as height 244 (e.g., 1-2 mm for a concrete surface). As shown in FIG. 21, device 10 may be provided with concave display 14. Concave

display 14 may be provided with a curvature defined by maximum depth 248 defined by the distance from the outermost surface of device 10, indicated by dashed line 246 and the deepest point in the curvature of display 14 (indicated by dashed line 214). The outermost surface of device 10 may be defined by bezel 200, or, in the absence of bezel 200, may be defined by juncture point 250 at which the peripheral edges of display 14 meet housing 12.

Maximum depth 248 may be chosen to be larger than characteristic size 244 of surface features 242 of common drop surface 240. Providing device 10 with a concave display having curvature chosen to provide a maximum depth (depth 248) that is larger than characteristic height 244 may significantly reduce the risk of damage (e.g., scratches or other damage) to device 10 during a drop event.

Providing concave display 14 with flexible display layer 14A capable of conforming to the shape of cover layer 14C allows all layers of display 14 to be conformed to same concave shape. Providing device 10 with concave display 14 in which all layers of concave display 14 conform to the same concave shape may reduce the susceptibility of device 10 to damage when dropped on common drop surface 240 while providing additional internal volume 216 in which internal components may be positioned.

Electronic devices may be provided with concave displays that reduce the risk of damage in the event of a drop while maximizing the internal volume of the device. Concave displays may be formed from one or more flexible layers including a flexible display layer. The flexible display layer may be mounted to a rigid support structure or a rigid cover layer. Flexible display layers that conform to the curved shape of a rigid cover structure

provide additional internal volume in which internal components of the device may be positioned.

5 In accordance with an embodiment, an electronic device is provided that includes a housing and a concave display mounted in the housing, where the concave display has a rigid internal support structure having a concave surface and a flexible display layer attached to the rigid internal support structure that conforms to the concave surface of the rigid support structure.

10 In accordance with another embodiment, the concave display further includes a first adhesive layer and the first adhesive layer attaches the flexible display layer to the concave surface of the rigid internal support structure.

15 In accordance with another embodiment, the concave display further includes a touch-sensitive layer.

In accordance with another embodiment, the concave display further includes first and second adhesive layers, where the first adhesive layer attaches the flexible display layer to the touch-sensitive layer and  
20 where the second adhesive layer attaches the flexible display layer to the rigid internal support structure.

In accordance with another embodiment, the housing includes a bezel and the bezel surrounds a  
25 periphery of the concave display.

In accordance with another embodiment, the rigid internal support structure has a convex inner surface and the electronic device further includes at least one internal component mounted adjacent to the convex inner  
30 surface.

In accordance with another embodiment, the rigid internal support structure has at least one opening.

In accordance with another embodiment, the at least one opening includes a hole in the rigid internal



support structure and the at least one internal component is mounted in the hole in the rigid internal support structure.

In accordance with another embodiment, an  
5 electronic device is provided that includes a housing and a concave display mounted in the housing, where the concave display includes a rigid cover layer having at least one concave outer surface and at least one  
10 corresponding convex inner surface and includes a flexible display layer, where the flexible display layer conforms to the convex inner surface of the rigid cover layer.

In accordance with another embodiment, the flexible display layer includes image pixels formed from organic light-emitting diodes.

15 In accordance with another embodiment, the concave display further includes a first adhesive layer, where the first adhesive layer attaches the flexible display layer to the convex inner surface of the rigid cover layer.

20 In accordance with another embodiment, the rigid cover layer has at least one opening, where the electronic device further includes an internal component and where the internal component is mounted adjacent to the flexible display layer under the at least one opening in the rigid  
25 cover layer.

In accordance with another embodiment, the internal component includes a speaker and the speaker transmits sound through the flexible display layer.

In accordance with another embodiment, the  
30 internal component includes a button, where the electronic device further includes a button member in the at least one opening in the rigid cover layer, where the button member moves within the at least one opening in the rigid cover layer, and where the movement of the button member

compresses the button.

In accordance with another embodiment, an electronic device is provided that includes an electronic device housing and a concave display mounted in the electronic device housing, where the concave display includes a rigid cover layer having a concave outer surface and a convex inner surface, a flexible display layer, and a touch-sensitive layer, where the flexible display layer and the touch-sensitive layer each conform to the convex inner surface of the rigid cover layer.

In accordance with another embodiment, the concave display further includes first and second adhesive layers, where the flexible display layer is attached to the touch-sensitive layer with the first adhesive layer and where the touch-sensitive layer is attached to the convex inner surface of the rigid cover layer with the second adhesive layer.

In accordance with another embodiment, the electronic device further includes at least one internal component mounted adjacent to the flexible display layer of the concave display.

In accordance with another embodiment, the rigid cover layer of the concave display has at least one opening, where the at least one internal component is an audio component, and where the audio component is mounted under the at least one opening in the rigid cover layer.

In accordance with another embodiment, the concave outer surface of the concave display has a curvature and peripheral edges, where the curvature has a deepest point, where the deepest point and at least some of the peripheral edges define a maximum depth associated with the curvature of the concave display and where the maximum depth of the concave display is between 0.5 millimeter and 20 millimeters.

In accordance with another embodiment, the electronic device further includes an internal component, where the internal component is mounted at a distance from the peripheral edges of the concave outer surface, and  
5 where the distance is smaller than the maximum depth.

The foregoing is merely illustrative of the principles of this invention and various modifications can be made by those skilled in the art without departing from the scope and spirit of the invention.

10 As shown in the examples of FIGS. 1, 2 and 22-29, an electronic device may be provided with a convex display. The convex display may include a flexible display layer that has been bent to form a curved surface.

Convex displays may be formed from flexible  
15 layers such as a flexible display layer (e.g., a flexible organic light-emitting diode array), a flexible touch-sensitive layer (e.g., a sheet of polymer with an array of transparent capacitor electrodes for a capacitive touch sensor), a flexible substrate layer, etc. These flexible  
20 layers may, if desired, be covered by a flexible or rigid cover layer (sometimes referred to as a cover glass) or may be supported by a support structure (e.g., a rigid support structure on the underside of the flexible  
25 layers). In electronic devices with convex displays partially covered by rigid cover layers, the cover layers may be provided with openings that provide access to the flexible layers of the display. For example, a cover glass layer may have an opening that allows a button member to move relative to the cover glass layer. As the  
30 button member moves within the opening, underlying portions of the flexible display may be deformed (e.g., to allow actuation of an associated switch).

Electronic devices may also be provided with user interface components (input-output components) such

as buttons, microphones, speakers, piezoelectric actuators or (for receiving electrical input from a user or tactile feedback to users), other actuators such as vibrators, pressure sensors, and other components. These components  
5 may be mounted under portions of a flexible display.

User interface components may be mounted under the flexible display or may be integrated into the flexible display. The deformable nature of the flexible display may allow a user to interact with the user  
10 interface components (input-output components) by moving the display into contact with the user interface components or by otherwise allowing the display to locally flex (e.g., to allow sound to pass through the flexible display or to allow a barometric pressure measurements of  
15 the exterior environment to be made by an internal pressure sensor). If desired, a portion of the flexible display may form a membrane portion of an electrical component. Components that may be provided with a membrane that is formed from a portion of a flexible  
20 display include microphones, laser microphones, pressure sensors, speakers, etc.

Convex displays formed from flexible and rigid layers that all have convex shapes i.e., displays formed from a collection of layers in which no layer of the  
25 display is planar) may provide an aesthetically desirable external appearance while maximizing the internal volume of the device that is available to hold electrical and mechanical device components.

An illustrative electronic device of the type  
30 that may be provided with a convex display is shown in FIG. 1.

Electronic device 10 may be a portable electronic device or other suitable electronic device. For example, electronic device 10 may be a laptop computer, a tablet

computer, a somewhat smaller device such as a wrist-watch device, pendant device, or other wearable or miniature device, a cellular telephone, a media player, etc.

Device 10 may include a housing such as housing 5 12. Housing 12, which may sometimes be referred to as a case, may be formed of plastic, glass, ceramics, fiber composites, metal (e.g., stainless steel, aluminum, etc.), other suitable materials, or a combination of these materials. In some situations, parts of housing 12 may be 10 formed from dielectric or other low-conductivity material. In other situations, housing 12 or at least some of the structures that make up housing 12 may be formed from metal elements.

Device 10 may have a convex display such as 15 convex display 14. Convex display 14 may be formed from multiple layers of material. These layers may include a touch sensor layer such as a layer on which a pattern of indium tin oxide (ITO) electrodes or other suitable transparent electrodes have been deposited to form a 20 capacitive touch sensor array or a touch sensor layer formed using other touch technologies (e.g., resistive touch, acoustic touch, optical touch, etc.). These layers may also include layer that contains an array of display pixels. The touch sensor layer and the display layer may 25 be formed using flexible sheets of polymer or other substrates having thicknesses of 10 microns to 0.5 mm or other suitable thicknesses (as an example).

The display pixel array may be, for example, an 30 organic light-emitting diode (OLED) array containing rows and columns of OLED display pixels. Other types of flexible display pixel arrays may also be formed (e.g., electronic ink displays, etc.). The use of OLED technology to form flexible display 14 is sometimes described herein as an example. This is, however, merely

illustrative. Flexible display 14 may be formed using any suitable flexible display technology. The use of flexible displays that are based on OLED technology is merely illustrative.

5           In addition to these functional display layers (i.e., the OLED array and the optional touch sensor array), display 14 may include one or more structural layers. For example, display 14 may be covered with a flexible or rigid cover layer and/or may be mounted on a  
10 support structure (e.g., a rigid support). Layers of adhesive may be used in attaching flexible display layers to each other and may be used in mounting flexible display layers to rigid and flexible structural layers.

          In configurations for display 14 in which the  
15 cover layer for display 14 is flexible, input-output components that rely on the presence of flexible layers may be mounted at any suitable location under the display (e.g., along peripheral portions of the display, in a central portion of the display, etc.). In configurations  
20 for display 14 in which the flexible layers are covered by a rigid cover glass layer or other rigid cover layer, the rigid layer may be provided with one or more openings and the electronic components may be mounted under the openings. For example, a rigid cover layer may have  
25 openings such as a circular opening 16 for button 17 and a speaker port opening such as speaker port opening 18 (e.g., for an ear speaker for a user). Device 10 may also have other openings (e.g., openings in display 14 and/or housing 12 for accommodating volume buttons, ringer  
30 buttons, sleep buttons, and other buttons, openings for an audio jack, data port connectors, removable media slots, etc.).

          In some embodiments, portions of convex display 14 such as peripheral regions 20I may be inactive and

portions of display 14 such as rectangular central portion 20A (bounded by dashed line 20) may correspond to the active part of display 14. In active display region 20A, an array of image pixels may be used to present text and images to a user of device 10. In active region 20A, display 14 may include touch sensitive components for input and interaction with a user of device 10. If desired, regions such as regions 20I and 20A in FIG. 1 may both be provided with display pixels (i.e., all or substantially all of the entire front planar surface of a device such as device 10 may be covered with display pixels).

Device 10 may, if desired, have internal user interface components such as buttons 17 or speaker component 19 that occupy openings such as openings 16 and 18 respectively in an optional rigid cover layer of convex display 14. Buttons 17 may be based on dome switches or other switch circuitry. Buttons 17 may include button members that form push buttons (e.g., momentary buttons), slider switches, rocker switches, etc. Device 10 may include internal structural components such as structural component 22 that add a raised structure to a portion of convex display 14. Device 10 may include components such as interface components 24 and 26 that may be fully internal to device 10, but that receive input from the user or from the surrounding environment through physical interaction with convex display 14. Interface components 22, 24, and 26 may be positioned in active region 20A or inactive region 20I of convex display 14. Interface components 22, 24, and 26 may be positioned separately from one another or may be commonly located to form a combined component with structural and internal features. Interface components 24 and 26 may be positioned underneath convex display 14 so that convex display 14

must be deformed in order to contact components 24 or 26 or, if desired may be positioned to remain in constant contact with convex display 14.

An exploded perspective view of an illustrative display is shown in FIG. 2. As shown in FIG. 2, convex display 14 may be formed by stacking multiple layers including flexible display layer 14A, touch-sensitive layer 14B, and cover layer 14C. Display 14 may also include other layers of material such as adhesive layers, optical films, or other suitable layers. Flexible display layer 14 may include image pixels formed from light-emitting diodes (LEDs), organic LEDs (OLEDs), plasma cells, electronic ink elements, liquid crystal display (LCD) components, or other suitable image pixel structures compatible with flexible displays.

Touch-sensitive layer 14B may incorporate capacitive touch electrodes such as horizontal transparent electrodes 32 and vertical transparent electrodes 34. Touch-sensitive layer 14B may, in general, be configured to detect the location of one or more touches or near touches on touch-sensitive layer 14B based on capacitive sensors, resistive sensors, optical sensors, acoustic sensors, inductive sensors, or force sensors.

Software and/or hardware may be used to process the measurements of the detected touches to identify and track one or more gestures. A gesture may correspond to stationary or non-stationary, single or multiple, touches or near touches on touch-sensitive layer 14B. A gesture may be performed by moving one or more fingers or other objects in a particular manner on touch-sensitive layer 14B such as tapping, pressing, rocking, scrubbing, twisting, changing orientation, pressing with varying pressure and the like at essentially the same time, contiguously, or consecutively. A gesture may be



characterized by, but is not limited to a pinching, sliding, swiping, rotating, flexing, dragging, or tapping motion between or with any other finger or fingers. A single gesture may be performed with one or more hands, by one or more users, or any combination thereof.

Cover layer 14C may be formed from plastic or glass (sometimes referred to as display cover glass) and may be flexible or rigid. If desired, the interior surface of peripheral inactive portions 20I of cover layer 14C may be provided with an opaque masking layer on such as black ink.

Touch-sensitive flexible display section 14AB may be formed from display pixel array layer 14A and optional touch sensor layer 14B.

FIG. 22 is perspective view of an exemplary embodiment of device 10 with convex display 14 and convex housing 12 in which housing 12 has an opening 300 that may provide access to, e.g., an audio port. A portion of housing 12 may form a bezel such as bezel 304. Bezel 304 may be formed so that bezel 304 and display 14 form a common smooth surface or may be formed raised above or depressed below the outer surface of display 14. Bezel 304 may be a separate bezel member or may be formed as a portion of housing 12. As shown in FIG. 22, top and bottom portions 306 of bezel 200 may have a convex (curved) shape that matches the cross-sectional curved shape of convex display 14.

FIG. 23 is a cross-sectional side view of an illustrative embodiment of device 10 taken along line 302 of FIG. 22 and viewed in direction 303. As shown in FIG. 23, device 10 has a convex shape formed by convex housing 12 and convex display 14. Device 10 may also include internal components such as battery 310 and components 312. The convex shape of housing 12 and display 14 of

device 10 may provide device 10 with a thin appearance while providing an interior space that is able to accommodate internal components such as battery 310.

FIG. 24 is a cross-sectional side view of an illustrative embodiment of device 10 in which convex display 14 is formed by mounting flexible display layer 14A to a convex support structure such as support structure 320 (e.g., a rigid support structure having at least a convex external surface such as a metal, glass, or plastic support structure) using a layer of adhesive material such as adhesive layer 322. As shown in FIG. 24, the internal volume of device 10, defined by housing 12 and convex display 14 may include volume 326 above plane 324 (defined by inner edges 328 of display 14) and below inner surface 330 of display 14. This is because inner surface 330 of support structure 320 is concave (in the FIG. 24 example). Volume 326 provides space which may be used for placement of internal components such as component 332 (e.g., printed circuit boards, antennas or other components). The ability to bend flexible display layer 14A into the convex shape of FIG. 24 that matches the convex outer surface of support structure 320 may therefore help maximize the interior space that is available within device 10 to mount device components.

FIG. 25 is a cross-sectional side view of a portion of device 10. In the illustrative embodiment of FIG. 25, convex display 14 is formed from flexible display layer 14A, adhesive layer 322, and rigid cover layer 14C (e.g., a layer of rigid plastic or a layer of rigid cover glass having a convex external surface and a concave inner surface to which flexible display layer 14A conforms). Convex display 14 may be formed adjacent to bezel portion housing 12 or may be joined to housing 12 by an additional mounting member. Providing device 10 with a layer such as

flexible display layer 14A that conforms to the convex shape of cover layer 14C (i.e., so that layer 14A conforms to the concave inner surface of layer 14C) may provide additional internal volume 326 between plane 324 (defined by inner edges 328 of display 14) and inner surface 330 of display 14.

FIG. 26 is a cross-sectional side view of a portion of another embodiment of device 10. In the illustrative embodiment of FIG. 26, convex display 14 is formed from flexible display layer 14A attached to optional touch-sensitive layer 14B by adhesive layer 322. Touch-sensitive layer 14B may further be attached to rigid cover layer 14C (e.g., a glass or plastic layer) using adhesive layer 340 such that all layers (322, 14B, 340, and 14C) of display 14 conform to the convex shape of cover layer 14C (i.e., so that layers 14A and 14B conform to the concave inner surface of cover layer 14C). Convex display 14 may be formed adjacent to housing 12 or may be joined to housing 212 by an additional mounting member. The convex shape of all layers (14A, 322, 14B, 340, and 14C) may combine with convex housing 12 to provide a thin appearance for device 10 and may provide additional internal volume 326 between plane 324 (defined by inner edges 328 of display 14) and inner surface 330 of display 14.

FIG. 27 is a cross-sectional perspective view of an illustrative electronic device 10 in the vicinity of a connecting structure such as connecting structure 350 (e.g. an audio port or other female connector). As shown in FIG. 27, audio port 350 may have electrical contacts 352 for mating with contacts 356 of a connector such as mating connector 354 (e.g., a mating audio plug or other male connector). In the embodiment of FIG. 27, a portion of audio port 350 may occupy a portion of internal volume

326 above plane 324 (defined by inner edges 328 of display 14). The convex shape of display 14 of device 10 may provide a thin appearance and may provide additional internal volume 326 between plane 324 (defined by inner edges 328 of display 14) and inner surface 330 of display 14 in which a portion of mating connectors such as connector 350 may be mounted.

FIG. 28 is a cross-sectional side view of an illustrative electronic device 10 in the vicinity of a stack of components 360 such as printed circuit boards (PCBs), sensors, switches, connectors, battery structures, or other electronic components. In the embodiment shown in FIG. 28, some components 360 may be mounted partially or completely in a portion of internal volume 326 above plane 324 (defined by inner edges 328 of display 14). The convex shape of display 14 of device 10 may provide a thin appearance and may provide additional internal volume 326 between plane 324 (defined by inner edges 328 of display 14) and inner surface 330 of display 14 in which PCBs and other components 360 may be mounted. The example of FIG. 29 in which components 360 are mounted in volume 326 is merely illustrative. Other components or structures may occupy volume 326, if desired.

FIG. 29 is a cross-sectional side view of an illustrative electronic device in which display 14 of device 10 completely surrounds device 10. As shown in FIG. 29, device 10 may have convex front (upper) and rear (lower) surfaces that are joined along curved sidewalls. Display 14 may cover the front, rear, and sidewall surfaces of device 10 so as to completely surround electrical components 360 (e.g., printed circuit boards, integrated circuits, switches, sensors, etc.). Edges 372 may be joined by a joining member such as joining member 370. Member 370 may be a separate member formed of

plastic, glass, ceramics, fiber composites, metal (e.g., stainless steel, aluminum, etc.), other suitable materials, or a combination of these materials, or may be formed from an adhesive material.

5           In the example of FIG. 29, display 14 may be formed by stacking multiple layers including flexible display layer 14A, touch-sensitive layer 14B, and cover layer 14C. Display 14 may also include other layers of material such as adhesive layers, optical films, or other  
10 suitable layers. As an example, display 14 may be formed by mounting flexible display layer 14A to a rigid convex support structure having one or more convex outer surfaces and one or more associated concave inner surfaces that completely surrounds device 10. In another configuration,  
15 display 14 may be formed from flexible display layer 14A, adhesive layer 322, and rigid cover layer 14C (e.g., a rigid cover layer with one or more convex outer surfaces and one or more associated concave inner surfaces). In another possible configuration, convex display 14 may be  
20 formed by attaching flexible display layer 14A to optional touch-sensitive layer 14B using adhesive layer 322. Touch-sensitive layer 14B may further be attached to rigid cover layer 14C (e.g., a glass or plastic layer) using adhesive layer 340 so that all layers (322, 14B, 340, and  
25 14C) of display 14 conform to the convex shape of cover layer 14C. These examples are merely illustrative and other configurations of display 14 may be used.

          The convex shape of display 14 of device 10 may provide a thin appearance for device 10 and may help to  
30 maximize the internal volume of the device in which components such as battery 310, PCBs 360 or other components such as component 312 may be mounted. Surrounding device 10 completely with convex display 14 may allow the area of a device available for visual

display to be enlarged.

The foregoing is merely illustrative of the principles of this invention and various modifications can be made by those skilled in the art without departing from  
5 the scope and spirit of the invention.

Electronic devices may be provided with convex displays. A convex display may be used to maximize the internal volume of a device. Convex displays may be formed from one or more flexible layers. A flexible  
10 display layer may be mounted to a rigid support structure or a rigid cover layer. Flexible display layers that conform to the curved shape of a rigid structure may provide additional internal volume in which internal components of the device may be positioned.

15 In accordance with another embodiment, an electronic device is provided including a housing and a display mounted in the housing, where the display has a flexible display layer that conforms to a convex outer surface of a rigid support structure.

20 In accordance with another embodiment, the display further includes an adhesive layer and the adhesive layer attaches the flexible display layer to the convex outer surface of the rigid support structure.

In accordance with another embodiment, the  
25 display further includes a touch-sensitive layer.

In accordance with another embodiment, the display further includes first and second adhesive layers, where the first adhesive layer attaches the flexible display layer to the touch-sensitive layer and the second  
30 adhesive layer attaches the flexible display layer to the convex outer surface of the rigid support structure.

In accordance with another embodiment, the flexible display layer includes image pixels formed from organic light-emitting diodes.

In accordance with another embodiment, the housing has at least one opening, where the opening is associated with a connector port and the electronic device further includes a connector structure mounted in the connector port.

In accordance with another embodiment, an electronic device is provided that includes a housing and a display mounted in the housing, where the display includes a rigid cover layer having at least one convex outer surface and having at least one associated concave inner surface and includes a flexible display layer that conforms to the concave inner surface.

In accordance with another embodiment, the display further includes an adhesive layer and the adhesive layer bonds the flexible display layer to the concave inner surface of the rigid cover layer.

In accordance with another embodiment, the rigid cover layer includes glass.

In accordance with another embodiment, the flexible display layer includes image pixels formed from organic light-emitting diodes.

In accordance with another embodiment, the flexible display layer includes image pixels formed from organic light-emitting diodes.

In accordance with another embodiment, the display further includes a touch sensor layer that conforms to the concave inner surface.

In accordance with another embodiment, the concave display further includes first and second adhesive layers, where the first adhesive layer attaches the flexible display layer to the touch sensor layer and the second adhesive layer attaches the touch sensor layer to the concave inner surface of the display.

In accordance with another embodiment, the touch

sensor layer includes indium-tin-oxide electrodes.

In accordance with another embodiment, the electronic device further includes an internal component, where the concave inner surface of the display provides an additional internal volume for the electronic device and  
5 where the internal component is mounted at least partially in the additional internal volume.

In accordance with another embodiment, an electronic device is provided having at least a front  
10 surface and a rear surface and including electronic components interposed between the front and rear surfaces and a display that substantially covers at least the front and rear surfaces and that surrounds the electronic components, where the display includes a rigid cover layer  
15 having at least one inner surface and a flexible display layer that is bent to conform to the inner surface.

In accordance with another embodiment, the display further includes a touch-sensitive layer attached to at least a portion of the flexible display layer.

In accordance with another embodiment, the inner  
20 surface includes a concave inner surface and the electronic device further includes a connector structure and a housing having an opening, where the connector structure is mounted in the opening to form a connector  
25 port.

In accordance with another embodiment, the electronic device has at least two sidewall surfaces and the display substantially covers the two sidewall surfaces.

In accordance with another embodiment, the  
30 display has at least two edges and the edges of the display are joined by a joining member.

The foregoing is merely illustrative of the principles of this invention and various modifications can



be made by those skilled in the art without departing from the scope and spirit of the invention. The foregoing embodiments may be implemented individually or in any combination.

5           As shown in the examples of FIGS. 30-44, an electronic device may be provided with a flexible display and other user interface components. The user interface components may include buttons, switches, microphones, actuators such as solenoids, motors, and piezoelectric  
10 actuators, connector ports, touch screens, proximity sensors and other components for accepting input from, or transmitting information to, a user of the electronic device.

          Flexible displays may be formed from flexible  
15 layers such as a flexible display layer (e.g., a flexible organic light-emitting diode array), a flexible touch-sensitive layer (e.g., a sheet of polymer with an array of transparent capacitor electrodes for a capacitive touch sensor), a flexible substrate layer, etc. These flexible  
20 layers may, if desired, be covered by a flexible or rigid cover layer (sometimes referred to as a cover glass) or may be supported by a support structure (e.g., a rigid support structure on the underside of the flexible  
layers). In electronic devices with flexible displays  
25 that are covered by rigid cover layers, the cover layers may be provided with openings that provide access to the flexible layers of the display in the vicinity of a user interface device. For example, a cover glass layer may have an opening that allows a button member to move  
30 relative to the cover glass layer. As another example, a cover glass layer may have one or more speaker openings through which sound may pass.

          To maximize the area of the portion of the flexible display that is available for displaying visual

information to the user, user interface components may be positioned behind, abutted against, or integrated into the flexible display. The deformable nature of the flexible display may allow a user to interact with the user  
5 interface components (input-output components) by moving the display into contact with the user interface components or by otherwise allowing the display to locally flex (e.g., to allow sound to pass through the flexible display or to allow barometric pressure measurements of  
10 the exterior environment to be made by an internal pressure sensor).

If desired, a portion of the flexible display may form a membrane structure for an electrical component. For example, a portion of the flexible display may form a  
15 speaker membrane for a speaker component. Components that may be provided with a membrane structure formed from a portion of a flexible display include speakers, microphones, laser microphones, pressure sensors, etc.

An illustrative electronic device of the type  
20 that may be provided with a flexible display is shown in FIG. 30. Electronic device 10 may be a computer such as a computer that is integrated into a display. For example, electronic device 10 may be a computer monitor, a laptop computer, a tablet computer, a somewhat smaller portable  
25 device such as a wrist-watch device, pendant device, or other wearable or miniature device, a cellular telephone, a media player, a tablet computer, a gaming device, a speaker device, a navigation device, a computer monitor, a television, or other electronic equipment.

30 Device 10 may include a housing such as housing 412. Housing 412, which may sometimes be referred to as a case, may be formed of plastic, glass, ceramics, fiber composites, metal (e.g., stainless steel, aluminum, etc.), other suitable materials, or a combination of these

materials. In some situations, parts of housing 412 may be formed from dielectric or other low-conductivity material. In other situations, housing 412 or at least some of the structures that make up housing 412 may be  
5 formed from metal elements.

Housing 412 may be formed using a unibody configuration in which some or all of housing 412 is machined or molded as a single structure or may be formed using multiple structures (e.g., an internal frame  
10 structure, one or more structures that form exterior housing surfaces, etc.).

As shown in FIG. 30, housing 412 may have multiple parts. For example, housing 412 may have upper portion 412A and lower portion 412B. Upper portion 412A  
15 may be coupled to lower portion 412B using a hinge that allows portion 412A to rotate about rotational axis 416 relative to portion 412B. A keyboard such as keyboard 418 and a touch pad such as touch pad 420 may be mounted in housing portion 412B.

Device 10 may have a flexible display such as flexible display 414. Flexible display 414 may be formed from multiple layers of material. These layers may include a touch sensor layer such as a layer on which a pattern of indium tin oxide (ITO) electrodes or other  
25 suitable transparent electrodes have been deposited to form a capacitive touch sensor array. These layers may also include a display layer that contains an array of display pixels. The touch sensor layer and the display layer may be formed using flexible sheets of polymer  
30 (e.g., polyimide) or other substrates having thicknesses of 10 microns to 0.5 mm, having thicknesses of less than 0.2 mm, or having other suitable thicknesses (as examples).

The display pixel array may be an organic light-

emitting diode (OLED) array, for example. Other types of flexible display pixel arrays may also be formed (e.g., electrowetting displays, electrophoretic displays, flexible liquid crystal displays, flexible electrochromic displays, etc.). The use of OLED technology to form flexible display 414 is sometimes described herein as an example. This is, however, merely illustrative. In general, any suitable type of flexible display technology may be used in forming display 414.

10 In addition to these functional display layers (i.e., the OLED array and the optional touch sensor array), display 414 may include one or more structural layers. For example, display 414 may be covered with a flexible or rigid cover layer and/or may be mounted on a support structure (e.g., a rigid support). If desired, layers of adhesive may be used to attach flexible display layers to each other and/or to mount flexible display layers to rigid and flexible structural layers.

20 In some embodiments, display 414 may have an active area such as active area AA and an inactive area such as area IA. In active display region AA, an array of image pixels may be used to present text and images to a user of device 10. In active region AA, display 414 may include touch sensitive components for input and interaction with a user of device 10. If desired, both central portion AA and peripheral portion IA may be provided with display pixels (i.e., all or substantially all of the entire front planar surface of upper housing portion 412A may be provided with display pixels).

30 In the example of FIG. 31, device 10 has been implemented using a housing that is sufficiently small to fit within a user's hand (e.g., device 10 of FIG. 31 may be a handheld electronic device such as a cellular telephone). As show in FIG. 31, device 10 may include a

display such as display 414 mounted on the front of housing 412. Display 414 may be substantially filled with active display pixels or may have an inactive portion such as inactive portion IA that surrounds an active portion such as active portion AA. Display 414 may have openings (e.g., openings in inactive region IA or active region AA of display 414) such as an opening to accommodate button 422 and an opening to accommodate speaker port 424.

FIG. 32 is a perspective view of electronic device 10 in a configuration in which electronic device 10 has been implemented in the form of a tablet computer. As shown in FIG. 32, display 414 may be mounted on the upper (front) surface of housing 412. An opening may be formed in display 414 to accommodate button 422 (e.g., an opening may be formed in inactive region IA surrounding active region AA).

FIG. 33 is a perspective view of electronic device 10 in a configuration in which electronic device 10 has been implemented in the form of a television or in the form of a computer integrated into a computer monitor. As shown in FIG. 33, display 414 may be mounted on the front surface of housing 412. Stand 426 may be used to support housing 412. Display 414 may include an inactive region such as inactive region IA that surrounds active region AA.

An exploded perspective view of an illustrative display is shown in FIG. 34. As shown in FIG. 34, flexible display 414 may be formed by stacking multiple layers including flexible display layer 414A and touch-sensitive layer 414B. An optional cover layer such as cover layer 462 may be formed over flexible display 414. Cover layer 462 may be a layer of glass, plastic, or other protective display layer.

Flexible display 414 may also include other

layers of material such as adhesive layers, optical films, sealant layers, or other suitable layers. Flexible display layer 414A may include image pixels formed from light-emitting diodes (LEDs), organic LEDs (OLEDs), plasma cells, electrowetting display elements, electrophoretic display elements, liquid crystal display (LCD) components, or other suitable image pixel structures compatible with flexible displays.

Touch-sensitive layer 414B may incorporate capacitive touch electrodes such as horizontal transparent electrodes 432 and vertical transparent electrodes 434. Touch-sensitive layer 414B may, in general, be configured to detect the location of one or more touches or near touches on touch-sensitive layer 414B based on capacitive, resistive, optical, acoustic, inductive, or mechanical measurements, or any phenomena that can be measured with respect to the occurrences of the one or more touches or near touches in proximity to touch sensitive layer 414B.

Flexible display 414 may be formed from display pixel array layer 414A and optional touch sensor layer 414B. In the example of FIG. 34, touch-sensitive layer 414B is interposed between cover layer 462 and flexible display layer 414A. This arrangement is merely illustrative. If desired, flexible display layer 414A may be interposed between cover layer 462 and touch-sensitive layer 414B (e.g., flexible display layer 414A may be arranged on top of touch-sensitive layer 414B). If desired, touch-sensitive layer 414B and flexible display layer 414A may be integrated as a single layer. For example, capacitive touch electrodes such as electrodes 432 and 434 and display pixels such as display pixels 430 may be formed on a common substrate, if desired.

FIG. 35 is a cross-sectional side view of a

portion of flexible display layer 414A. As shown in FIG. 35, flexible display layer 414A may contain multiple sublayers. For example, display layer 414A may include a substrate layer such as substrate layer 415. Substrate layer 415 may be formed from a flexible or rigid dielectric such as glass, ceramic, or plastic. As an example, substrate layer 415 may be formed from one or more flexible sheets of polymer (e.g., polyimide). Substrate layer 415 may have a thickness of 10 microns to 0.5 mm, may have a thickness of less than 0.2 mm, or may have other suitable thickness (as examples).

A thin-film transistor (TFT) layer such as TFT layer 417 may include a layer of thin-film transistor structures (e.g., polysilicon transistors and/or amorphous silicon transistors) formed on substrate layer 415.

An organic emissive layer such as OLED layer 419 may be formed over TFT layer 417. OLED layer 419 may include a light-emitting material such as an array of organic light-emitting diode structures that are used to form display pixels such as display pixels 430 of FIG. 34.

A sealant layer such as sealant layer 421 may be formed over OLED layer 419 to protect the structures of OLED layer 419 and TFT layer 417. Sealant layer 421 may be formed from one or more layers of polymer (e.g., one or more layers of polymer that are deposited onto OLED layer 419), metal foil (e.g., a layer of metal foil that is laminated, sputtered, evaporated, or otherwise applied onto OLED layer 419), or other suitable coating or conformal covering.

Electronic device 10 may be provided with one or more speaker structures for providing sound to a user of electronic device 10. FIG. 36 is a cross-sectional side view of a portion of electronic device 10 in the vicinity of a speaker structure such as speaker structure 448.

Sound produced by speaker structure 448 may be transmitted through flexible display 414 to the exterior of device 10. Flexible display 414 may be used as a speaker membrane structure for speaker 448. Portions such as portion 414M that serve as a speaker membrane for speaker 448 may be located in an active or inactive portion of display 414. Arrangements in which speaker membrane 414M forms an active display area may allow the size of the active region of flexible display 414 to be increased relative to its inactive region.

As shown in FIG. 36, speaker structure 448 may be driven by a transducer such as transducer 450. Transducer 450 may be configured to receive electrical audio signal input from circuitry in device 10 and to convert the electrical signal into sound. In the example of FIG. 36, transducer 450 is formed from a magnet such as magnet 440 surrounded by coils such as coils 442. Magnet 440 may be a permanent magnet formed from ferrite material, ceramic material, iron alloy material, rare earth material, other suitable material, or a combination of these materials. Coils 442 may be formed from copper, aluminum, silver, other suitable materials, etc. If desired, there may be one or more sets of coils surrounding magnet 440.

When current passes through coils 442, a magnetic field is produced. This allows coils 442 to act as a variable electromagnet with a magnetic field that interacts with the constant magnetic field produced by permanent magnet 440. For example, the negative pole of the electromagnet may be repelled by the negative pole of permanent magnet 440. The magnetic force created by this repulsion will force magnet 440 away from coils 442. When the current flowing through coils 442 changes direction, the polarity of the variable electromagnet reverses.



Magnet 440 may be pushed back and forth rapidly (along the z-axis) as the current in coils 442 alternates directions.

Portions of flexible display 414 such as portion 414M may form a speaker membrane for speaker 448. As  
5 magnet 440 moves back and forth along the z-axis, attached speaker membrane 414M will in turn vibrate the air in front of speaker membrane 414M, creating sound waves.

In some arrangements, an optional support structure such as support structure 446 (sometimes  
10 referred to as a stiffening structure or stiffener) may be interposed between transducer 450 and speaker membrane 414M. Support structure 446 may be used to stiffen speaker membrane portion 414M of display 414. Support structure 446 may be formed from a metal plate, from  
15 specialized composite structures (e.g., a layer of foam interposed between layers of stiffener, etc.), from other support materials or stiffening structures, or from a combination of these materials. Using a support structure such as support structure 446 may allow speaker membrane  
20 414M to respond more accurately to the movement of magnet 440. In arrangements where optional support structure 446 is not used, magnet 440 may be configured to stiffen portion 414M of display 414 that serves as a speaker membrane structure.

25 There may be one or more speaker structures 448 in device 10. Some or all of speaker structures 448 in device 10 may have speaker membranes that are formed from flexible display 414. If desired, some, all, or substantially all of flexible display 414 may be used as a  
30 speaker membrane for one speaker, for two speakers, for three speakers, or for more than three speakers.

A suspension structure such as suspension structure 454 may be used to attach portions of flexible display 414 to a rigid support structure such as housing

412. Suspension structure 454 may prevent speaker membrane 414M from moving laterally along the x-axis and/or the y-axis, but may allow free motion of speaker membrane 414M along the z-axis as speaker 448 produces sound. Suspension structure 454 may be formed from an elastomeric material, foam material, resin coated material, other suitable materials, or a combination of these materials. As shown in the example of FIG. 36, suspension structure 454 may form a pliant interface between speaker membrane 414M and housing sidewalls 412S. This is merely illustrative. If desired, suspension structure 454 may form a pliant interface between speaker membrane 414M and any suitable surrounding housing structure or any suitable rigid support structure.

If desired, other suspension structures may be incorporated into speaker structure 448. For example, there may be one or more suspension structures attached to magnet 440. This type of suspension structure may provide a restoring force that returns magnet 440 to an equilibrium position after being displaced by magnetic forces.

The desired range of frequencies produced by speaker 448 may depend on several factors. For example, the desired range of frequencies produced by speaker 448 may depend on the type of electronic device in which speaker 448 is implemented, may depend on the location of speaker 448 in device 10, may depend on the other speaker structures that are being used in combination with speaker structure 448, etc. Design choices may be made to obtain a desired frequency response from speaker 448. For example, materials used in forming speaker 448 may be selected based on the desired frequency response.

The type of enclosure that surrounds speaker 448 may also be selected based on the desired frequency

response. For example, the enclosure that surrounds the speaker may be ported. As shown in FIG. 36, housing 412 may optionally be provided with an opening or port such as acoustic port 452 (sometimes referred to as a funnel, horn, vent, hole, etc.). Port 452 may be used to equalize the pressure between the inside of housing 412 and the outside of housing 412. This may in turn augment the sound waves produced by speaker 448. A ported enclosure such as the ported enclosure shown in the example of FIG. 36 may increase the magnitude of low-frequency sound waves produced by speaker 448 (e.g., a speaker with a ported enclosure may have a higher bass output than a speaker with a sealed enclosure).

As shown in FIG. 36, port 452 may have a portion such as portion 452P that protrudes into the enclosure. The size and shape of protruding portion 452P may be customized to obtain a desired frequency response. For example, protruding portion 452P of port 452 may have a "horn" shape, in which the diameter of opening 452 varies along the length of portion 452P. Protruding portion 452P may have a curved shape, if desired. In general, protruding portion 452P may have any suitable shape, and opening 452 may have any suitable size. The characteristics of port 452 will depend on the desired frequency response of speaker 448, the structure of device 10, etc., and may be modified accordingly. The example shown in FIG. 36 is merely illustrative.

If desired, speaker 448 may be provided with a sealed enclosure that does not have a port. The example of FIG. 36 in which housing 412 is provided with port 452 is merely illustrative. The type of enclosure into which speaker 448 is implemented (e.g., a sealed enclosure, a ported enclosure, etc.) will depend on the desired frequency response of speaker 448, the structure of device

10, etc., and may be modified accordingly.

Electronic device 10 may have internal components or structures such as internal component 456. Internal components such as internal component 456 may optionally be used to tune the resonant frequency of speaker 448. Internal component 456 may be a battery or other internal structure. If desired, optional component 456 may be omitted or may otherwise not be used to tune the resonant frequency of speaker 448.

If desired, housing 412 may have one or more raised edges such as optional raised portion 412'. Raised portion 412' may have an upper surface that lies above the upper surface of display 414 (e.g., the upper surface of raised portion 412' may protrude above the upper surface of flexible display 414 in vertical dimension z).

Optional raised housing 412' may allow a user to hold device 10 in hand without disrupting the speaker functionality of display 414. Raised portion 412' of housing 412 may surround the entire periphery of display 414, or may be located on one side of display 414, on two sides of display 414, on three sides of display 414, or on all four sides of display 414. Raised portion 412' may be formed as an integral part of housing 412 or may be formed as a separate structure in contact with housing 412.

FIG. 37 is a cross-sectional side view of a portion of electronic device 10 in the vicinity of another possible embodiment of speaker structure 448. As shown in FIG. 37, speaker structure 448 may be driven by a transducer such as transducer 450. In the example of FIG. 37, transducer 450 may be formed from one or more central sets of coils 442 surrounded by a magnet such as magnet 440. In some arrangements, inner portion 444 of coils 442 may also contain a magnet structure (e.g., coils 442 may surround a magnet structure). Magnet structures that are

formed within inner portion 444 of coils 442 may be formed as an integral part of outer magnet 440 (e.g., may be joined above and/or below coils 442) or may be a separate magnet structure. If desired, inner portion 444 of coils  
5 442 may be free of magnet structures.

As with the transducer of FIG. 36, transducer 450 of FIG. 37 may be configured to receive electrical audio signal input from circuitry in device 10 and to convert the electrical signal into sound. As current  
10 passes through coils 442, a magnetic field is produced. The magnetic field produced by coils 442 interacts with the constant magnetic field produced by permanent magnet 440. The interaction of the electromagnet with the constant magnetic field will create a magnetic force  
15 between coils 442 and magnet 440 (e.g., an attractive or repulsive force). When the current flowing through coils 442 changes direction, the polarity of the variable electromagnet (and thus the direction of magnetic force) is reversed. Coils 442 may be pushed back and forth  
20 (along the z-axis) by the varying magnetic force as the current in coils 442 alternates directions.

As coils 442 move back and forth, attached speaker membrane 414M will in turn vibrate the air in front of speaker membrane 414M, creating sound waves.  
25 Support structure 446 may be used to stiffen speaker membrane 414M so that membrane portion 414M of flexible display 414 responds accurately to the movement of transducer 450.

In the example of FIG. 37, speaker 448 may be  
30 provided with a sealed enclosure that does not have a port. This is merely illustrative. Any suitable type of enclosure (e.g., a sealed enclosure, a ported enclosure, etc.) may be used. The type of enclosure into which speaker 448 is implemented will depend on the desired

frequency response of speaker 448, the structure of device 10, etc., and may be modified accordingly.

FIG. 38 is a cross-sectional side view of a portion of device 10 in the vicinity of another possible embodiment of speaker structure 448. In the example of FIG. 38, speaker 448 is supported by a rigid structure within device 10 such as rigid structure 466. Rigid structure 466 may be formed from housing structures or internal components, or may be a dedicated structure used to form a frame (sometimes referred to as a chassis or "basket") or other rigid support structure for speaker 448. Suspension structure 454 may be used to form a pliant interface between speaker 448 and rigid structure 466. As with the suspension structure of FIGS. 7 and 8 (in which suspension structure 454 is attached to housing sidewalls 412S), suspension structure 454 of FIG. 38 may prevent speaker membrane portions 414M of display 414 from moving laterally along the x-axis and/or the y-axis, but may allow free motion of speaker membrane 414M along the z-axis as speaker 448 produces sound. Suspension structure 454 may be attached to any suitable portion of speaker 448 (e.g., support structure 446, magnet 440, speaker membrane portion 414M, etc.)

The type of arrangement shown in FIG. 38 may be beneficial for configurations in which speaker 448 is not in the vicinity of housing sidewalls 412S or in other configurations in which speaker 448 is not attached to housing 412. For example, speaker 448 may be located in the central portion of a large display. In this type of configuration, a rigid structure such as rigid structure 466 of FIG. 38 may be used to support speaker 448, if desired.

There may be one or more speakers 448 in device 10. Multiple speakers 448 may be attached to a common

rigid structure 466 or each speaker 448 may be attached to a separate rigid structure 466.

If desired, a cover layer such as optional cover layer 462 may be formed over flexible display 414. Cover layer 462 may be formed from glass, plastic, or other suitable material. Cover layer 462 may allow a user to hold device 10 in hand without disrupting the speaker functionality of display 414. Cover layer 462 may also serve to protect display 414 and other parts of device 10 while still allowing speaker membrane 414M to move freely along the z-axis as speaker 448 produces sound. Cover layer 462 may be in contact with display 414 or there may be a gap 463 interposed between cover layer 462 and display 414. Gap 463 may be filled with air or may include a layer of material such as a layer of sealant (as an example).

One or more holes such as holes 464 (sometimes referred to as openings or speaker openings) may be formed in cover layer 462 so that sound may pass from speaker 448 to the exterior of device 10.

A perspective view of device 10 showing how holes 464 may be formed in cover layer 462 is shown in FIG. 39. As shown in FIG. 39, holes 464 may be formed in a "speaker grill" fashion in which an array of openings is formed in front of one or more speakers. Holes 464 may be formed in cover layer 462 in any suitable location. For example, holes 464 may be formed in localized areas of cover layer 462 that overlap a speaker structure, or holes 464 may be formed in a uniform array that covers some, all, or substantially all of the front surface of display 414. Holes 464 may have any suitable size. For example, holes 464 may have a diameter between .25 mm and .5 mm, between .5 mm and 1 mm, between 1 mm and 1.5 mm, more than 1.5 mm, less than 1.5 mm, etc. The size, shape, and

number of openings 464 formed in cover layer 462 may depend on the type and number of speakers 448 in device 10.

FIG. 40 is a cross-sectional side view of device 10 in the vicinity of support structure 446. Support structure 446 may be used to stiffen portions of flexible display 414. As discussed in connection with FIG. 36, stiffening structure 446 may be formed from a metal plate, from fiber-based composite materials, from laminated layers of one or more materials, or from other suitable materials. As shown in the example of FIG. 40, stiffening structure 446 may be formed from a layer of foam 474 interposed between first and second stiffening sheets 472. Sheets 472 may be formed from polymer, metal, glass, ceramic, fiber-based composites, or other suitable materials. This type of structure may provide a stiff and lightweight support structure for display 414. If desired, support structure 446 may be used to stiffen speaker membrane portions 414M of display 414, may be used to stiffen other portions of display 414, or may be used to stiffen all or substantially all of display 414.

Support structure 446 may be shaped in any desired fashion. For example, support structure 446 may be curved, may be planar, or may have a combination of curved and planar portions.

FIG. 41 is a cross-sectional side view of device 10 in the vicinity of curved support structure 446. As shown in FIG. 41, flexible display 414 may conform to the shape of stiffening structure 446. In the example of FIG. 41 stiffening structure 446 has a curved shape so that flexible display 414 is concave. This is, however, merely illustrative. In general, stiffening structure 446 and the attached portion of display 414 may have any suitable shape. For example, stiffening structure 446 may have a



curved shape so that flexible display 414 is convex. The example of FIG. 41 in which display 414 has a concave shape may be suitable for configurations in which display 414 forms a speaker membrane for speaker 448. A concave shaped speaker membrane may improve the quality of sound produced by speaker 448. Speakers with convex membranes may also be used.

FIG. 42 is a cross-sectional side view of device 10 in the vicinity of a single speaker structure. As shown in FIG. 42, portion 414M of flexible display 414 may form a speaker membrane for speaker structure 448. Transducer 450 for speaker 448 may be any suitable type of transducer (e.g., one or more sets of coils surrounded by a magnet, one or more sets of coils surrounding a magnet, a piezoelectric transducer, a microphone transducer, a sensor, an actuator, etc.). Speaker 448 may be the only speaker in device 10 or may be one of a plurality of speakers in device 10. Display-based speaker structure 448 may be used in conjunction with speaker structures that are not display-based. For example, there may be other speakers in device 10 which do not use display 414 as a speaker membrane. Speaker structure 448 of FIG. 42 may use all or substantially all of display 414 as a speaker membrane (e.g., the entire front face of device 10 may be occupied by a speaker), or may use only a portion of display 414 as a speaker membrane.

In the example of FIG. 43, an array of transducers 450 may be used to form a plurality of display-based speakers 448. Display-based speaker structures 448 may be used in conjunction with speaker structures that are not display-based. Each display-based speaker 448 may have an associated transducer 450. Each associated transducer 450 may be any suitable type of transducer (e.g., one or more sets of coils surrounded by

a magnet, one or more sets of coils surrounding a magnet, a piezoelectric transducer, a microphone transducer, a sensor, an actuator, etc.). The type of transducer 450 used may be different for each speaker 448 (e.g., the array of speakers 448 in FIG. 43 may include different types of transducers, if desired). Providing speakers 448 with different types of transducers, different structures, and different characteristics may give device 10 the ability to produce sound with a wider range of frequencies.

FIG. 44 is a bottom view of a portion of device 10 showing how an array of display-based speakers such as the array shown in FIG. 43 may be implemented in device 10. In the example of FIG. 44, support structure 446 is formed on the underside of display 414. Support structure 446 may be used to stiffen speaker membrane portions 414M of display 414 (e.g., support structure 446 may be interposed between transducer 450 and display 414). Support structure 446 may also be used to stiffen portions of display 414 between adjacent speakers 448.

Each speaker 448 may be surrounded by a ring 414' of flexible display 414 that is not stiffened by support structure 446. Flexible ring-shaped portions 414' of flexible display 414 may provide a barrier structure around each speaker 448 that prevents interference between adjacent speakers 448. For example, as speaker membrane 414M vibrates, ring 414' (which is surrounded by support structure 446) may absorb vibrations moving laterally in display 414 (e.g., in directions along the x-axis and/or y-axis). This may allow adjacent speakers 448 to operate independently without being disrupted by the vibrations of a neighboring speaker.

If desired, speakers 448 may include a variety of speaker types. Examples of speaker types that may be

used for speakers 448 include subwoofers, woofers, mid-range speakers, tweeters, supertweeters, etc. If desired, different channels of audio input may be routed to each speaker. For example, speakers 448 may include a center channel speaker, a left channel speaker, a right channel speaker, a surround channel speaker, etc. Any suitable characteristic of speakers 448 (e.g., size, type, location, input channel, etc.) may be modified to achieve a desired frequency response and/or to accommodate the structure of device 10.

Electronic devices that contain flexible displays and one or more display-based speaker structures may be provided. The speaker structures may be positioned under the flexible display. Portions of the flexible display may be used as speaker membranes for the speaker structures. The speaker structures may be driven by transducers that convert electrical audio signal input into sound. Piezoelectric transducers or transducers formed from coils and magnets may be used to drive the speaker structures. Speaker membranes may be formed from active display areas of the flexible display. Some, all, or substantially all of the flexible display may be used as a speaker membrane for one or more display-based speaker structures. An optional cover layer may be provided with speaker openings so that sound may pass from the display-based speaker structures to the exterior of the device.

In accordance with another embodiment, an electronic device is provided including a flexible display and a speaker structure having a speaker membrane, where the speaker membrane is formed from a portion of the flexible display.

In accordance with another embodiment, the electronic device further includes a stiffening structure

configured to stiffen the portion of the flexible display that forms the speaker membrane.

In accordance with another embodiment, the stiffening structure includes a layer of foam.

5 In accordance with another embodiment, the stiffening structure includes first and second stiffening sheets that are attached to opposing first and second sides of the layer of foam.

10 In accordance with another embodiment, the flexible display includes an active portion configured to display images and the speaker membrane is formed from the active portion of the flexible display.

15 In accordance with another embodiment, the electronic device further includes a rigid structure and a suspension structure configured to attach portions of the speaker structure to the rigid structure.

20 In accordance with another embodiment, the electronic device further includes an electronic device housing in which the flexible display is mounted, where the rigid structure is formed at least partly from the electronic device housing.

25 In accordance with another embodiment, the electronic device further includes a cover layer formed over the flexible display, where the cover layer includes at least one opening formed over the speaker membrane.

30 In accordance with another embodiment, the electronic device further includes an electronic device housing in which the flexible display is mounted, where the electronic device housing has at least one acoustic port.

In accordance with another embodiment, the flexible display includes an organic light-emitting diode display having a substrate formed from a flexible sheet of polymer.

In accordance with another embodiment an electronic device is provided including a flexible display and a plurality of speaker structures, where portions of the flexible display form speaker membranes for the plurality of speaker structures.

In accordance with another embodiment, the electronic device further includes a plurality of stiffening structures configured to stiffen the portions of the flexible display that form the speaker membranes.

In accordance with another embodiment, the flexible display includes a set of stiffened regions, where each of the stiffened regions in the set of stiffened regions forms part of a respective one of the speaker structures, flexible regions, where each of the flexible regions surrounds a respective one of the stiffened regions in the set of stiffened regions, and a surrounding stiffened region, where each of the flexible regions is surrounded by portions of the surrounding stiffened region.

In accordance with another embodiment, the speaker structures include a left channel speaker and a right channel speaker.

In accordance with another embodiment, the electronic device further includes transducers configured to drive the speaker structures, where each transducer includes coils and a magnet.

In accordance with another embodiment, the electronic device further includes piezoelectric transducers configured to drive the speaker structures.

In accordance with another embodiment, the flexible display includes an organic light-emitting diode display having a substrate formed from a flexible sheet of polymer.

In accordance with another embodiment, a

portable electronic device is provided, including a housing, a flexible organic light-emitting diode display mounted in the housing, where the flexible organic light-emitting diode display has a substrate formed from a flexible sheet of polymer, and at least one speaker having a speaker membrane formed from a portion of the flexible sheet of polymer.

In accordance with another embodiment, the portable electronic device further includes a stiffening structure interposed between the at least one speaker and the speaker membrane, where the stiffening structure includes a composite material.

In accordance with another embodiment, the speaker membrane has a concave shape.

In accordance with another embodiment, the housing includes a rectangular housing with four peripheral edges and the flexible organic light-emitting diode display and the speaker membrane extend between the four peripheral edges.

The foregoing is merely illustrative of the principles of this invention and various modifications can be made by those skilled in the art without departing from the scope and spirit of the invention. The foregoing embodiments may be implemented individually or in any combination.

What is Claimed is:

1. An electronic device, comprising:  
a flexible display; and  
an internal component, wherein the flexible display may be deformed by an action external to the device, and wherein deformation of the flexible display creates a response from the internal component.

2. The electronic device defined in claim 1 wherein the flexible display comprises:  
a flexible display layer; and  
a touch-sensitive layer.

3. The electronic device defined in claim 2 wherein the flexible display layer of the flexible display includes an active display region, and wherein the internal component is covered with a portion of the active display region of the flexible display.

4. The electronic device defined in claim 3 wherein the internal component comprises a button, and wherein deformation of the flexible display compresses the button.

5. The electronic device defined in claim 4 wherein the flexible display further comprises a rigid cover layer having at least one opening.

6. The electronic device defined in claim 5 wherein the opening comprises a hole in the rigid cover layer, wherein the button further comprises a button member in the opening, wherein the button member moves within the hole in the rigid cover layer, and wherein the

movement of the button member in the opening causes deformation of the flexible display.

7. The electronic device defined in claim 3 wherein the internal component comprises a pressure sensor, and wherein deformation of the flexible display exerts a mechanical pressure on the pressure sensor.

8. The electronic device defined in claim 7 wherein the pressure sensor comprises a piezoelectric actuator, and wherein the mechanical pressure induces a voltage on the piezoelectric actuator.

9. The electronic device defined in claim 3 wherein the internal component comprises a laser microphone for detecting a sound originating external to the electronic device, and wherein detecting the sound comprises with a laser, detecting deformation of the flexible display.

10. An electronic device, comprising:  
a flexible display; and  
an audio component that transmits or receives sound through the flexible display.

11. The electronic device defined in claim 10 wherein the flexible display includes an active display region, and wherein the audio component is mounted behind the active display region of the flexible display.

12. The electronic device defined in claim 11 wherein the flexible display comprises:  
a flexible display layer; and  
a touch-sensitive layer.



13. The electronic device defined in claim 11 wherein the audio component comprises a diaphragm, and wherein the diaphragm is mounted in contact with the flexible display.

14. An electronic device, comprising:  
a housing;  
a flexible display mounted on the housing;  
and

a first internal component mounted under a portion of the flexible display, wherein the first internal component is configured to deform the portion of the flexible display.

15. The electronic device defined in claim 14 wherein the first internal component comprises a piezoelectric actuator, wherein a voltage applied to the piezoelectric actuator causes an expansion of the piezoelectric actuator, and wherein the portion of the flexible display deforms in response to the expansion of the piezoelectric actuator.

16. The electronic device defined in claim 14 wherein the first internal component comprises a structural component, wherein the portion of the flexible display deforms in response to physical contact with the structural component, and wherein deformation of the portion of the flexible display causes the portion of the flexible display to conform to a surface of the structural component.

17. The electronic device defined in claim 16 further comprising a second internal component mounted

under the portion of the flexible display, wherein the portion of the flexible display that conforms to the surface of the structural component indicates the location of the second internal component.

18. The electronic device defined in claim 17 wherein the second internal component comprises a button, wherein the portion of the flexible display is configured to be further deformed by an action external to the electronic device, and wherein further deformation of the portion of the flexible display compresses the button.

19. The electronic device defined in claim 16 wherein the first internal component further comprises an actuator, wherein the structural component is mounted on the actuator, wherein raising the actuator moves the structural component into contact with the portion of the flexible display, and wherein lowering the actuator moves the structural component out of contact with the flexible display.

20. The electronic device defined in claim 19 wherein the flexible display comprises a touch-sensitive layer and wherein deformation of the portion of the flexible display conforming to the surface of the structural component indicates the location of a portion of the touch-sensitive layer of the flexible display.

21. The electronic device defined in claim 19 further comprising a second internal component mounted on the actuator, and wherein deformation of the portion of the flexible display conforming to the surface of the structural component indicates the location of the second internal component.

22. The electronic device defined in claim 19 further comprising:

a cover member; and

an actuator switch coupled to the actuator, wherein deformation of the flexible display exerts a pressure on the cover member, and wherein the pressure on the cover member lifts the cover member.

23. An electronic device, comprising:

a housing; and

a concave display mounted in the housing, wherein the concave display has a rigid internal support structure having a concave surface and a flexible display layer attached to the rigid internal support structure that conforms to the concave surface of the rigid support structure.

24. The electronic device defined in claim 23 wherein the concave display further comprises a first adhesive layer, and wherein the first adhesive layer attaches the flexible display layer to the concave surface of the rigid internal support structure.

25. The electronic device defined in claim 23 wherein the concave display further comprises a touch-sensitive layer.

26. The electronic device defined in claim 25 wherein the concave display further comprises first and second adhesive layers, wherein the first adhesive layer attaches the flexible display layer to the touch-sensitive layer, and wherein the second adhesive layer attaches the flexible display layer to the rigid internal support

structure.

27. The electronic device defined in claim 23 wherein the housing comprises a bezel, and wherein the bezel surrounds a periphery of the concave display.

28. The electronic device defined in claim 26 wherein the rigid internal support structure has a convex inner surface and wherein the electronic device further comprises at least one internal component mounted adjacent to the convex inner surface.

29. The electronic device defined in claim 28, wherein the rigid internal support structure has at least one opening.

30. The electronic device defined in claim 29 wherein the at least one opening comprises a hole in the rigid internal support structure, and wherein the at least one internal component is mounted in the hole in the rigid internal support structure.

31. An electronic device, comprising:  
a housing; and  
a concave display mounted in the housing,  
wherein the concave display includes a rigid cover layer having at least one concave outer surface and at least one corresponding convex inner surface and includes a flexible display layer, wherein the flexible display layer conforms to the convex inner surface of the rigid cover layer.

32. The electronic device defined in claim 31 wherein the flexible display layer comprises image pixels formed from organic light-emitting diodes.

33. The electronic device defined in claim 31 wherein the concave display further comprises a first adhesive layer, and wherein the first adhesive layer attaches the flexible display layer to the convex inner surface of the rigid cover layer.

34. The electronic device defined in claim 33 wherein the rigid cover layer has at least one opening, wherein the electronic device further comprises an internal component, and wherein the internal component is mounted adjacent to the flexible display layer under the at least one opening in the rigid cover layer.

35. The electronic device defined in claim 34 wherein the internal component comprises a speaker and wherein the speaker transmits sound through the flexible display layer.

36. The electronic device defined in claim 34 wherein the internal component comprises a button, wherein the electronic device further comprises a button member in the at least one opening in the rigid cover layer, wherein the button member moves within the at least one opening in the rigid cover layer, and wherein the movement of the button member compresses the button.

37. An electronic device, comprising:  
an electronic device housing; and  
a concave display mounted in the electronic device housing, wherein the concave display comprises a rigid cover layer having a concave outer surface and a convex inner surface, a flexible display layer, and a touch-sensitive layer, wherein the flexible display layer

and the touch-sensitive layer each conform to the convex inner surface of the rigid cover layer.

38. The electronic device defined in claim 37 wherein the concave display further comprises first and second adhesive layers, wherein the flexible display layer is attached to the touch-sensitive layer with the first adhesive layer, and wherein the touch-sensitive layer is attached to the convex inner surface of the rigid cover layer with the second adhesive layer.

39. The electronic device defined in claim 38 further comprising at least one internal component mounted adjacent to the flexible display layer of the concave display.

40. The electronic device defined in claim 39 wherein the rigid cover layer of the convex display has at least one opening, wherein the at least one internal component is an audio component, and wherein the audio component is mounted under the at least one opening in the rigid cover layer.

41. The electronic device defined in claim 38 wherein the concave outer surface of the concave display has a curvature and peripheral edges, wherein the curvature has a deepest point, wherein the deepest point and at least some of the peripheral edges define a maximum depth associated with the curvature of the concave display and wherein the maximum depth of the concave display is between 0.5 millimeter and 20 millimeters.

42. The electronic device defined in claim 41 further comprising an internal component, wherein the

internal component is mounted at a distance from the peripheral edges of the concave outer surface, and wherein the distance is smaller than the maximum depth.

43. An electronic device, comprising:  
a housing; and  
a display mounted in the housing, wherein the display has a flexible display layer that conforms to a convex outer surface of a rigid support structure.

44. The electronic device defined in claim 43 wherein the display further comprises an adhesive layer, and wherein the adhesive layer attaches the flexible display layer to the convex outer surface of the rigid support structure.

45. The electronic device defined in claim 43 wherein the display further comprises a touch-sensitive layer.

46. The electronic device defined in claim 45 wherein the display further comprises first and second adhesive layers, wherein the first adhesive layer attaches the flexible display layer to the touch-sensitive layer, and wherein the second adhesive layer attaches the flexible display layer to the convex outer surface of the rigid support structure.

47. The electronic device defined in claim 46 wherein the flexible display layer comprises image pixels formed from organic light-emitting diodes.

48. The electronic device defined in claim 46, wherein the housing has at least one opening, wherein the

opening is associated with a connector port, the electronic device further comprising a connector structure mounted in the connector port.

49. An electronic device, comprising:  
a housing; and  
a display mounted in the housing, wherein the display includes a rigid cover layer having at least one convex outer surface and having at least one associated concave inner surface and includes a flexible display layer that conforms to the concave inner surface.

50. The electronic device defined in claim 49 wherein the display further comprises an adhesive layer, and wherein the adhesive layer bonds the flexible display layer to the concave inner surface of the rigid cover layer.

51. The electronic device defined in claim 49 wherein the rigid cover layer comprises glass.

52. The electronic device defined in claim 51 wherein the flexible display layer comprises image pixels formed from organic light-emitting diodes.

53. The electronic device defined in claim 49 wherein the flexible display layer comprises image pixels formed from organic light-emitting diodes.

54. The electronic device defined in claim 49 wherein the display further comprises a touch sensor layer that conforms to the concave inner surface.

55. The electronic device defined in claim 54



wherein the concave display further comprises first and second adhesive layers, wherein the first adhesive layer attaches the flexible display layer to the touch sensor layer, and wherein the second adhesive layer attaches the touch sensor layer to the concave inner surface of the display.

56. The electronic device defined in claim 55 wherein touch sensor layer comprises indium-tin-oxide electrodes.

57. The electronic device defined in claim 49 further comprising an internal component, wherein the concave inner surface of the display provides an additional internal volume for the electronic device, and wherein the internal component is mounted at least partially in the additional internal volume.

58. An electronic device having at least a front surface and a rear surface, comprising:

electronic components interposed between the front and rear surfaces; and

a display that substantially covers at least the front and rear surfaces and that surrounds the electronic components, wherein the display comprises a rigid cover layer having at least one inner surface and a flexible display layer that is bent to conform to the inner surface.

59. The electronic device defined in claim 58 wherein the display further comprises a touch-sensitive layer attached to at least a portion of the flexible display layer.

60. The electronic device defined in claim 58 wherein the inner surface comprises a concave inner surface, the electronic device further comprising a connector structure and a housing having an opening, wherein the connector structure is mounted in the opening to form a connector port.

61. The electronic device defined in claim 58 wherein the electronic device has at least two sidewall surfaces, and wherein the display substantially covers the two sidewall surfaces.

62. The electronic device defined in claim 61 wherein the display has at least two edges, and wherein the edges of the display are joined by a joining member.

63. An electronic device, comprising:  
a flexible display; and  
a speaker structure having a speaker membrane, wherein the speaker membrane is formed from a portion of the flexible display.

64. The electronic device defined in claim 63, further comprising:  
a stiffening structure configured to stiffen the portion of the flexible display that forms the speaker membrane.

65. The electronic device defined in claim 64 wherein the stiffening structure comprises a layer of foam.

66. The electronic device defined in claim 65 wherein the stiffening structure comprises first and

second stiffening sheets that are attached to opposing first and second sides of the layer of foam.

67. The electronic device defined in claim 63 wherein the flexible display comprises an active portion configured to display images and wherein the speaker membrane is formed from the active portion of the flexible display.

68. The electronic device defined in claim 63, further comprising:

a rigid structure; and  
a suspension structure configured to attach portions of the speaker structure to the rigid structure.

69. The electronic device defined in claim 68, further comprising:

an electronic device housing in which the flexible display is mounted, wherein the rigid structure is formed at least partly from the electronic device housing.

70. The electronic device defined in claim 63, further comprising:

a cover layer formed over the flexible display, wherein the cover layer comprises at least one opening formed over the speaker membrane.

71. The electronic device defined in claim 63 further comprising an electronic device housing in which the flexible display is mounted, wherein the electronic device housing has at least one acoustic port.

72. The electronic device defined in claim 63

wherein the flexible display comprises an organic light-emitting diode display having a substrate formed from a flexible sheet of polymer.

73. An electronic device, comprising:  
a flexible display; and  
a plurality of speaker structures, wherein portions of the flexible display form speaker membranes for the plurality of speaker structures.

74. The electronic device defined in claim 73, further comprising:  
a plurality of stiffening structures configured to stiffen the portions of the flexible display that form the speaker membranes.

75. The electronic device defined in claim 73 wherein the flexible display comprises:  
a set of stiffened regions, wherein each of the stiffened regions in the set of stiffened regions forms part of a respective one of the speaker structures;  
flexible regions, wherein each of the flexible regions surrounds a respective one of the stiffened regions in the set of stiffened regions; and  
a surrounding stiffened region, wherein each of the flexible regions is surrounded by portions of the surrounding stiffened region.

76. The electronic device defined in claim 73 wherein the speaker structures comprise a left channel speaker and a right channel speaker.

77. The electronic device defined in claim 73, further comprising:

transducers configured to drive the speaker structures, wherein each transducer comprises coils and a magnet.

78. The electronic device defined in claim 73 further comprising piezoelectric transducers configured to drive the speaker structures.

79. The electronic device defined in claim 73 wherein the flexible display comprises an organic light-emitting diode display having a substrate formed from a flexible sheet of polymer.

80. A portable electronic device, comprising:  
a housing;  
a flexible organic light-emitting diode display mounted in the housing, wherein the flexible organic light-emitting diode display has a substrate formed from a flexible sheet of polymer; and  
at least one speaker having a speaker membrane formed from a portion of the flexible sheet of polymer.

81. The portable electronic device defined in claim 80, further comprising:  
a stiffening structure interposed between the at least one speaker and the speaker membrane, wherein the stiffening structure comprises a composite material.

82. The portable electronic device defined in claim 80 wherein the speaker membrane has a concave shape.

83. The portable electronic device defined in claim 80 wherein the housing comprises a rectangular

housing with four peripheral edges and wherein the flexible organic light-emitting diode display and the speaker membrane extend between the four peripheral edges.

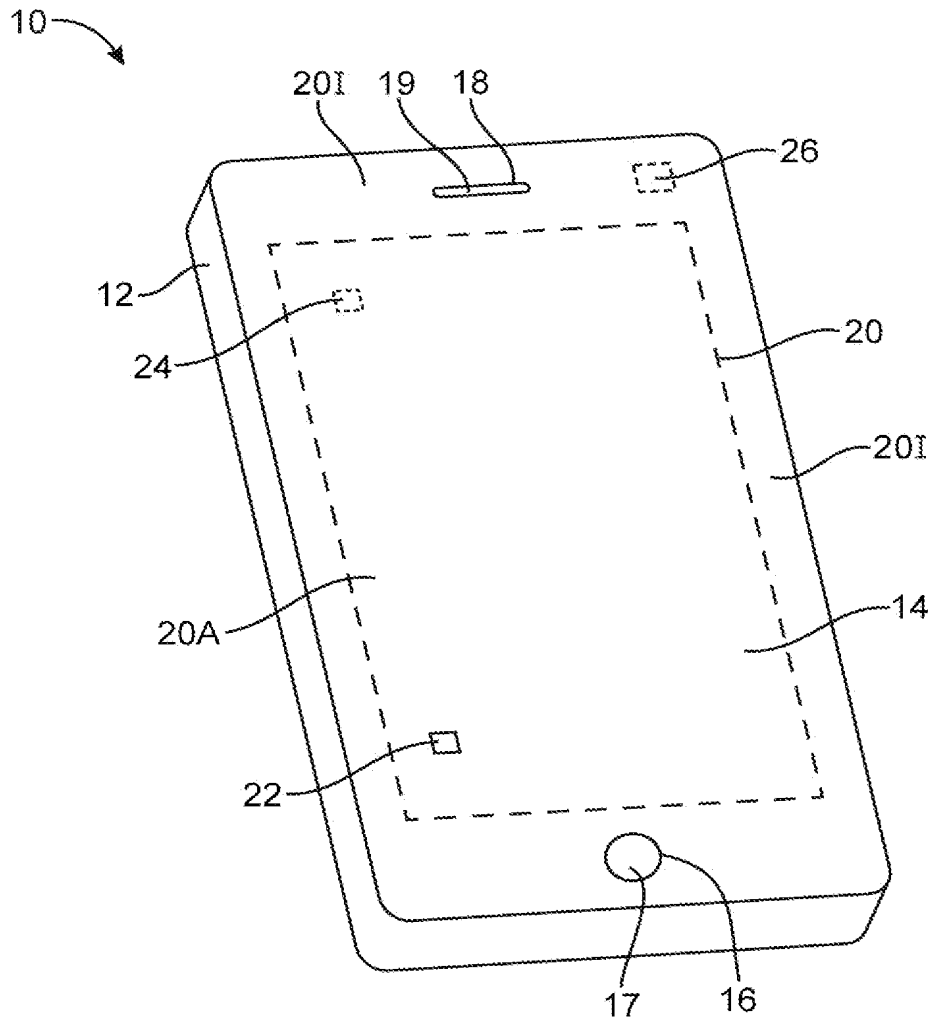

FIG. 1

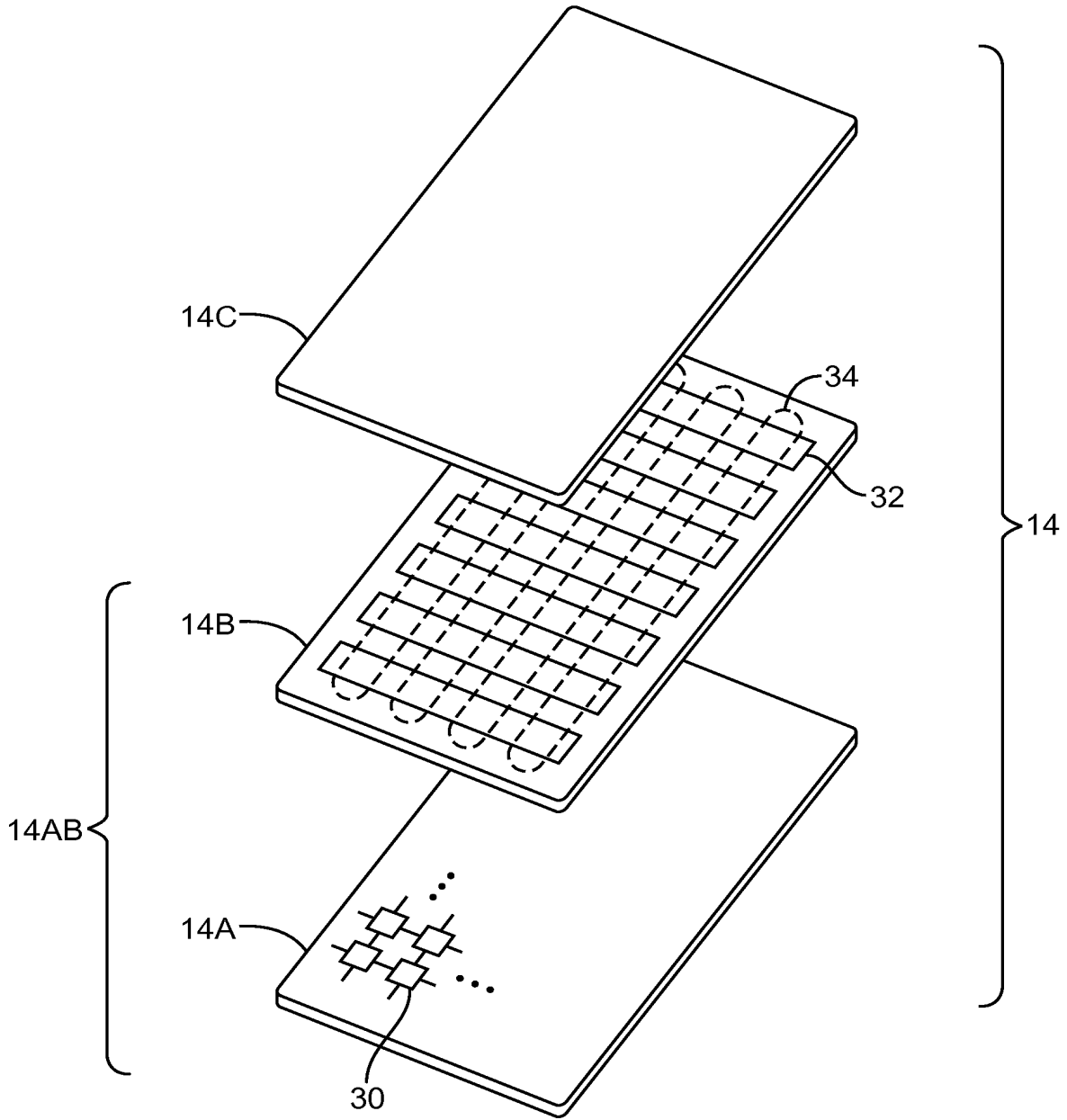

FIG. 2



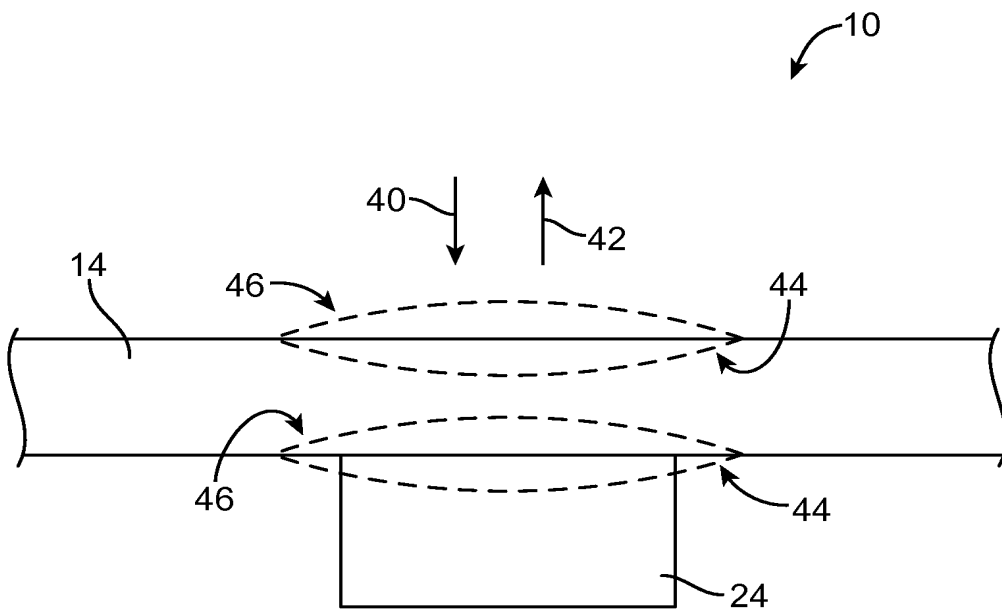

FIG. 3

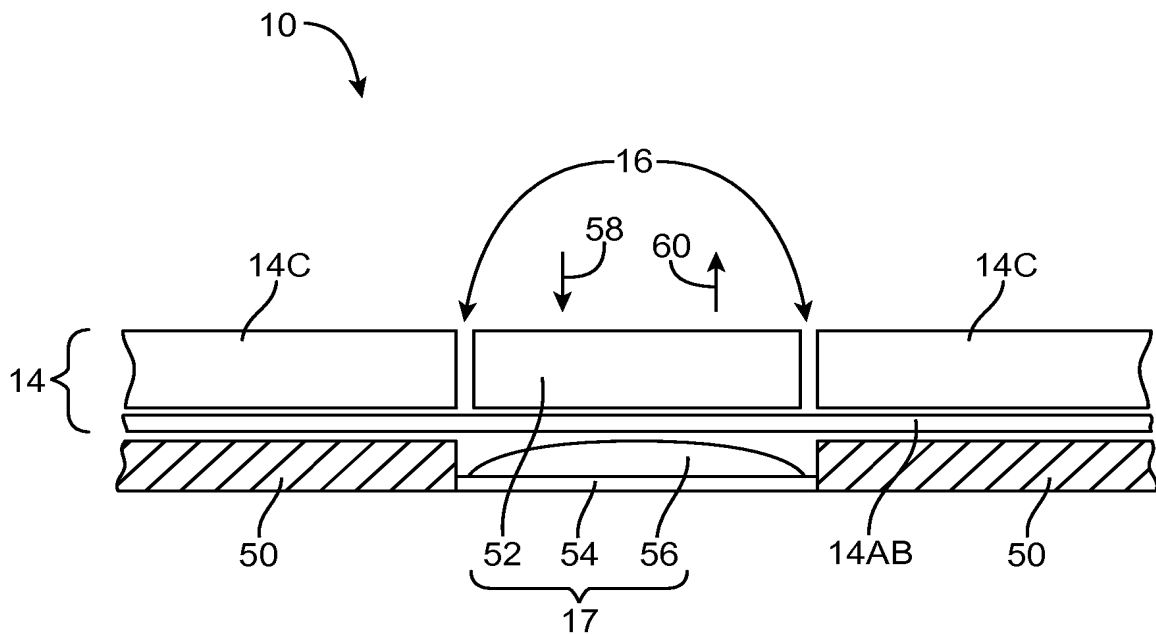

FIG. 4

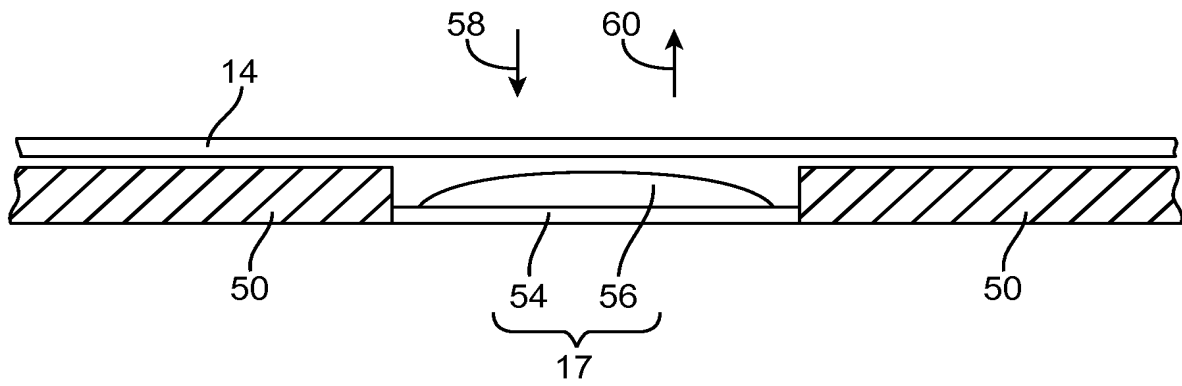

FIG. 5

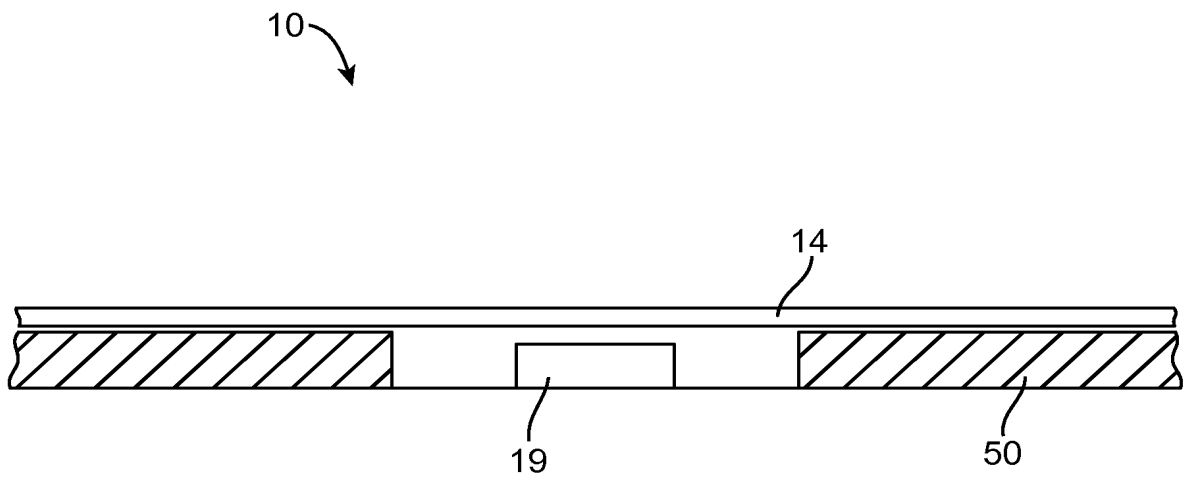

FIG. 6

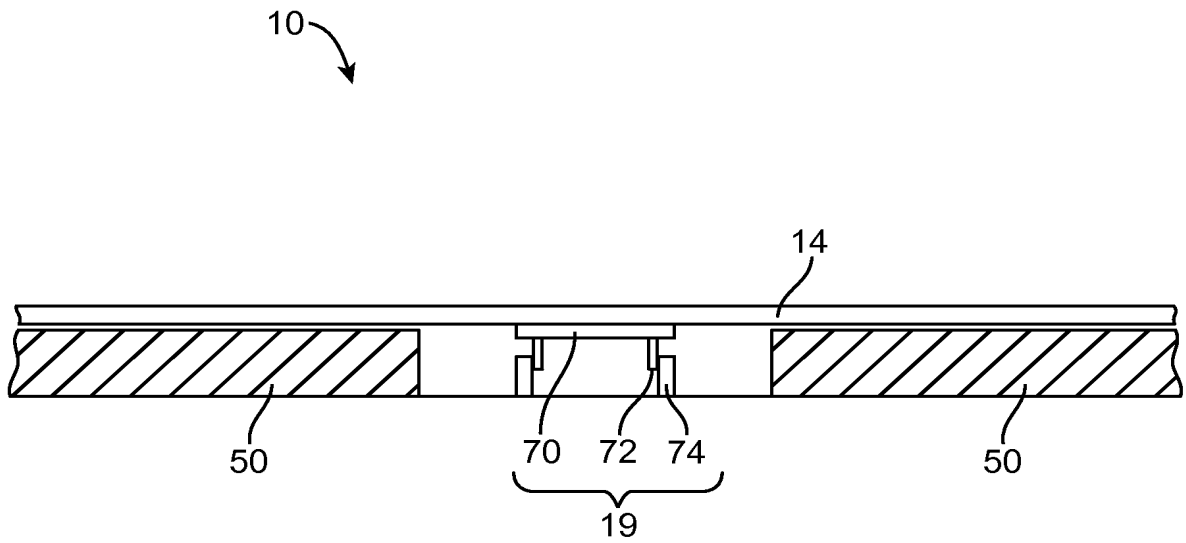

FIG. 7

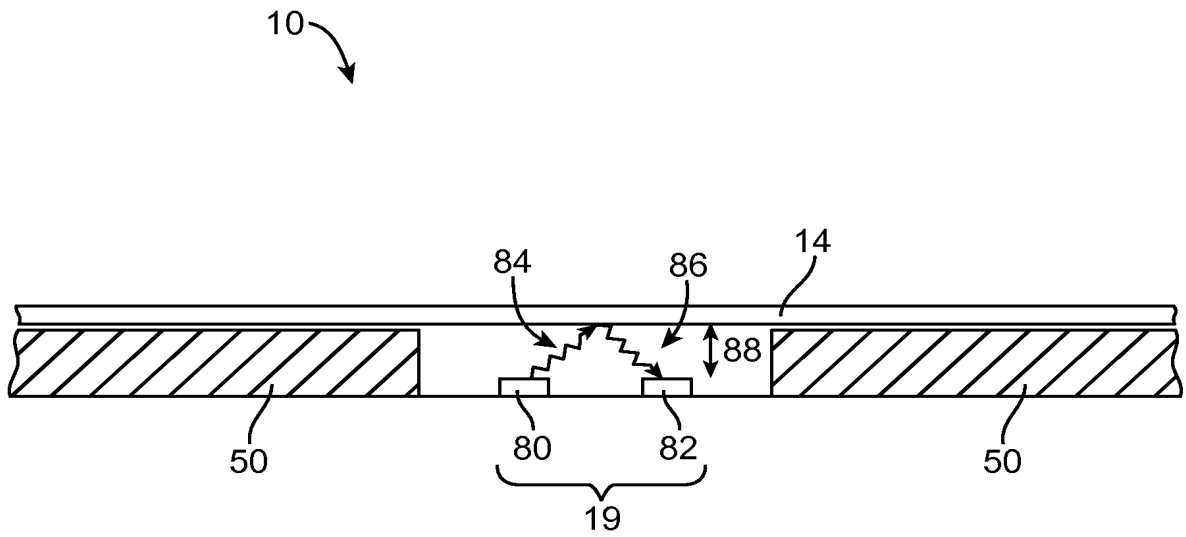

FIG. 8

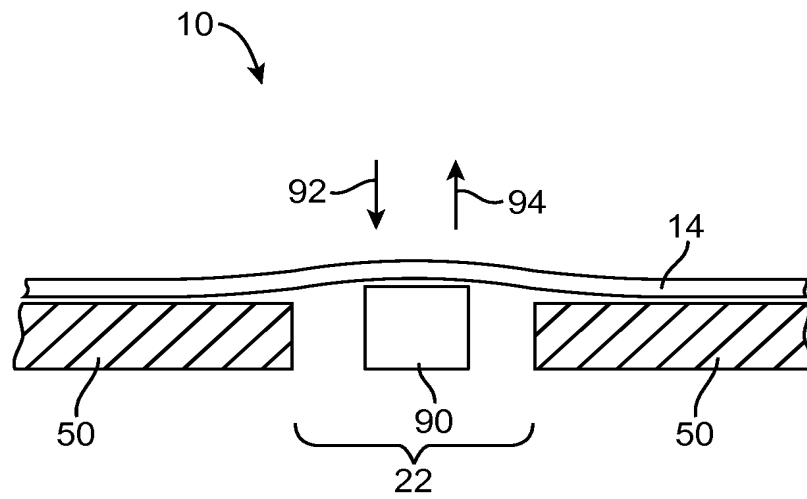

FIG. 9

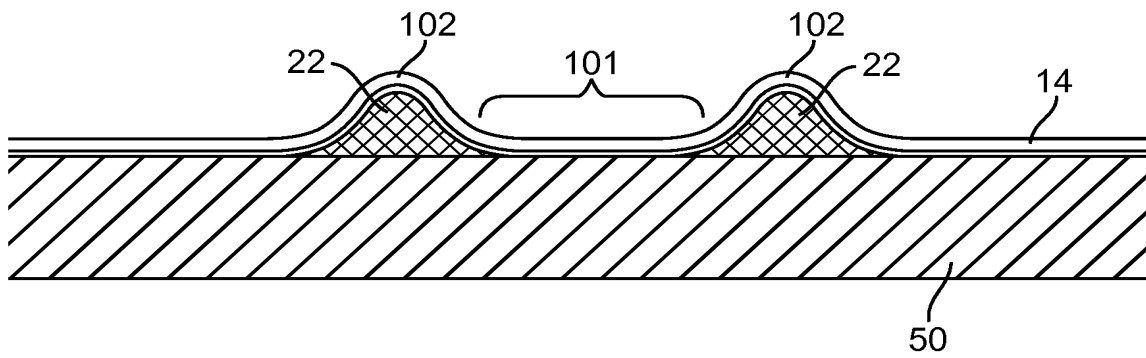

FIG. 10



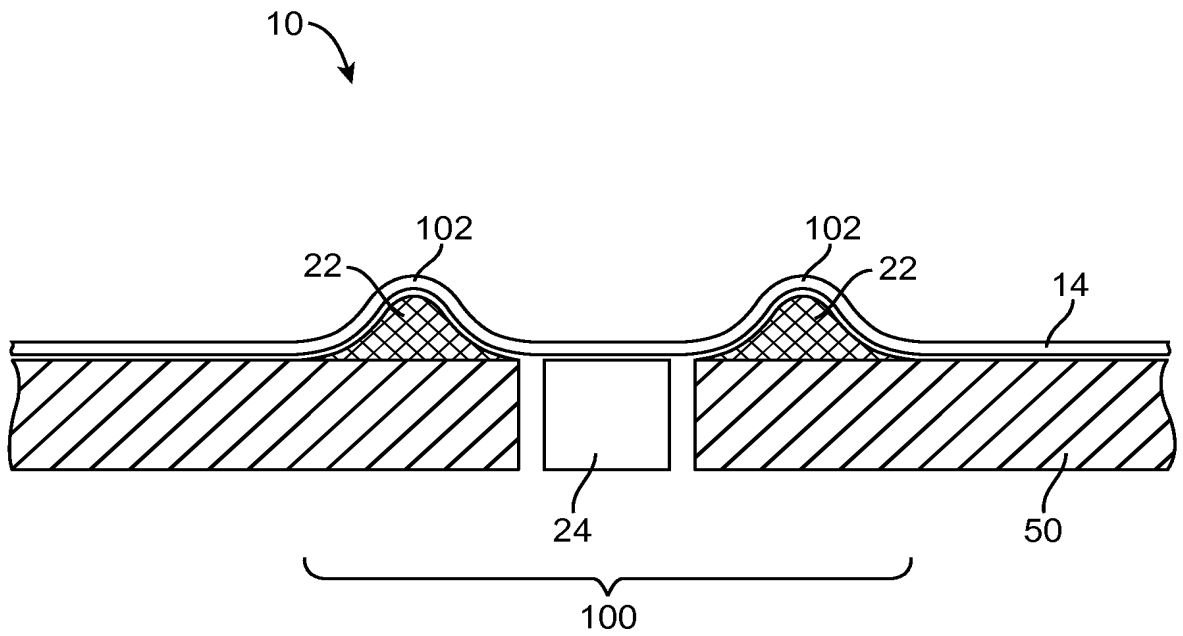

FIG. 11

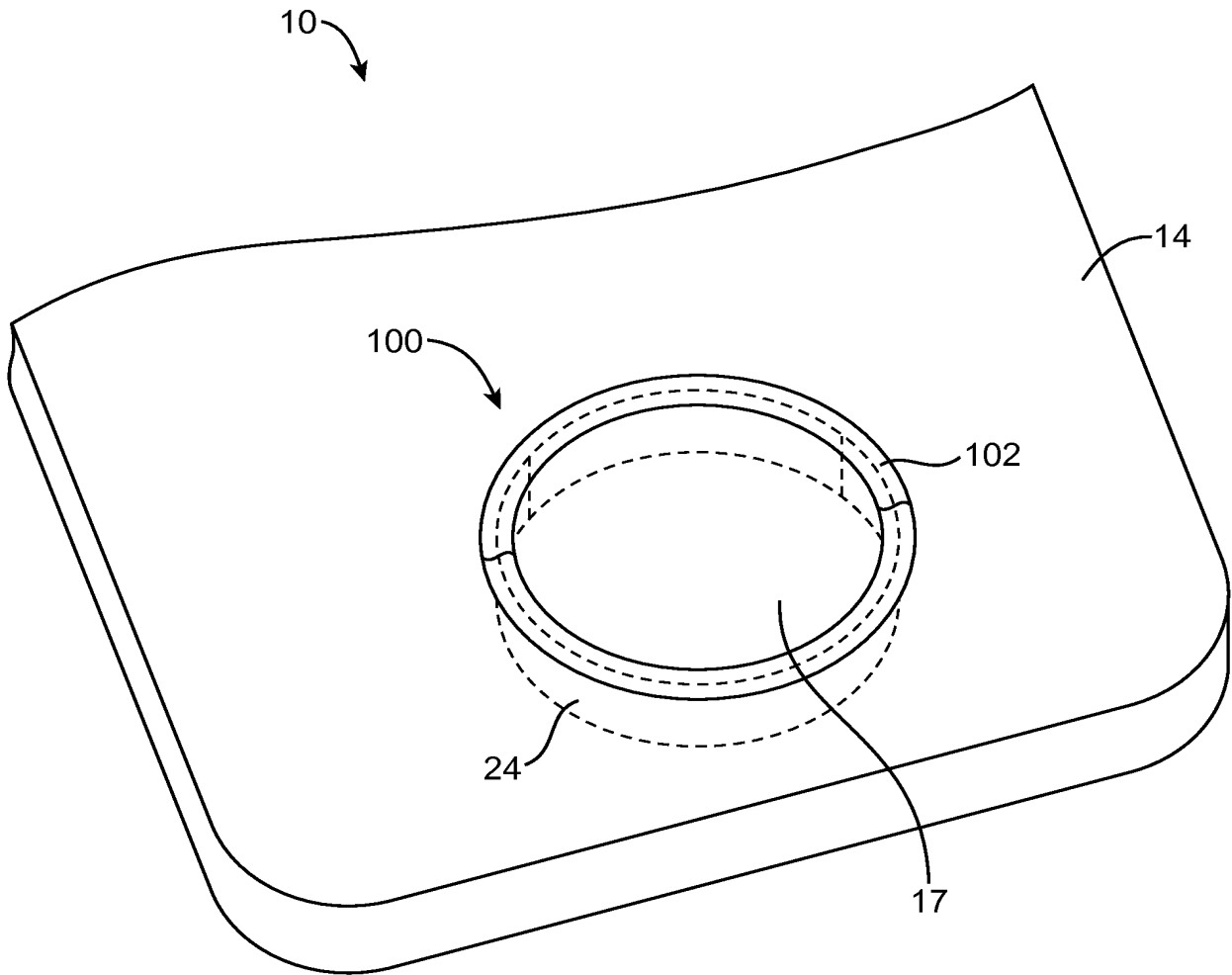

FIG. 12

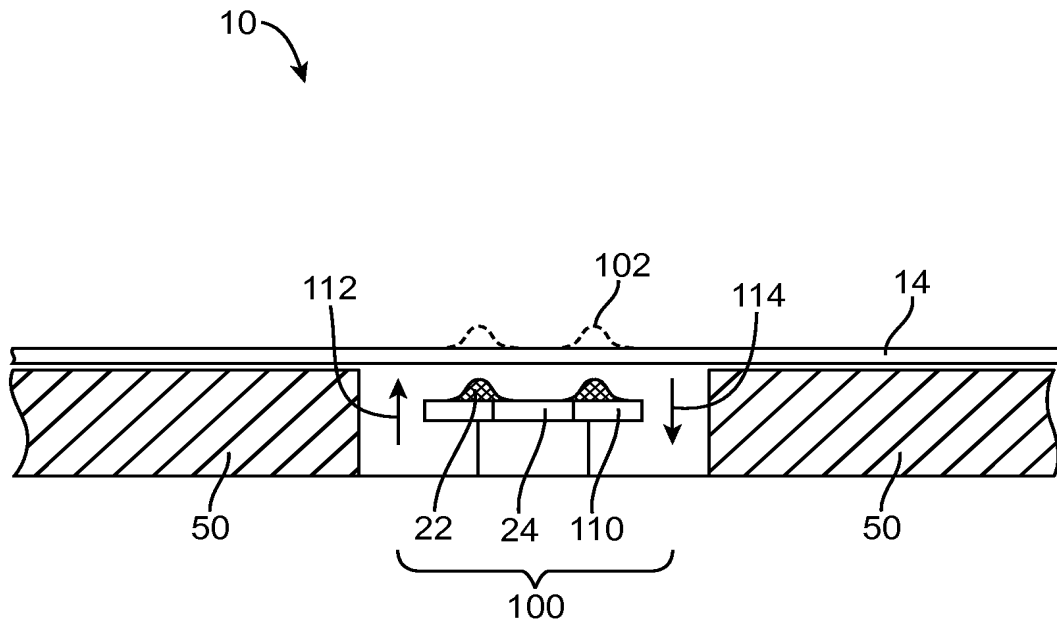

FIG. 13

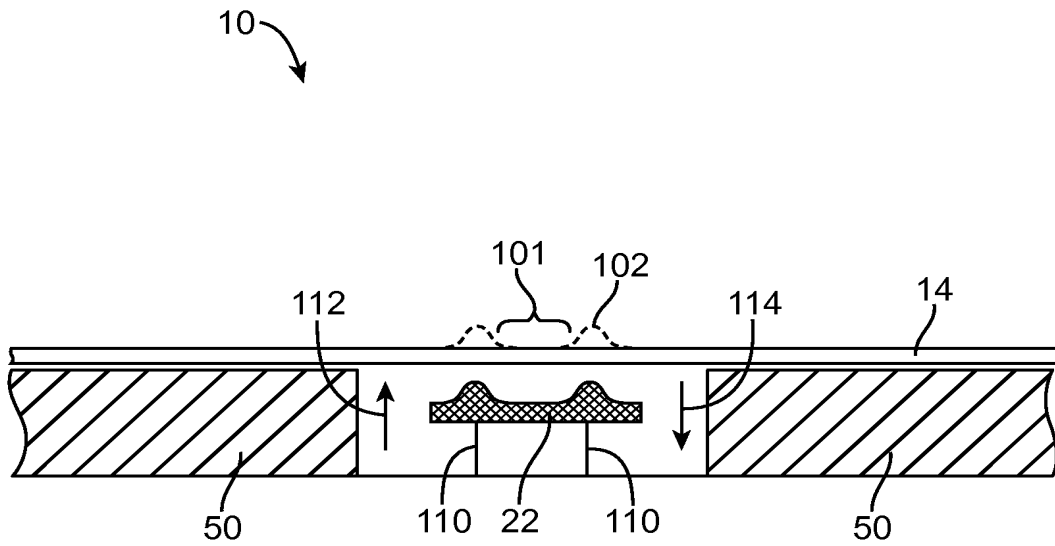

FIG. 14

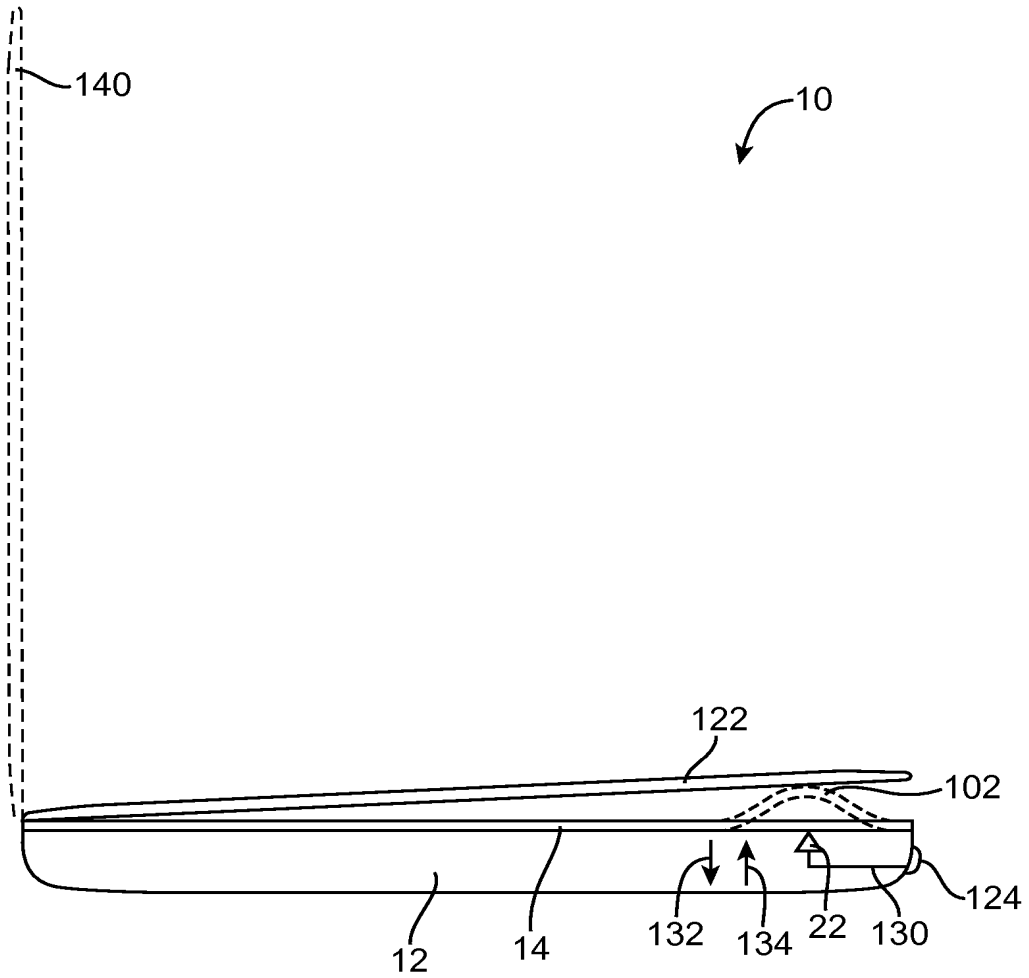

FIG. 15

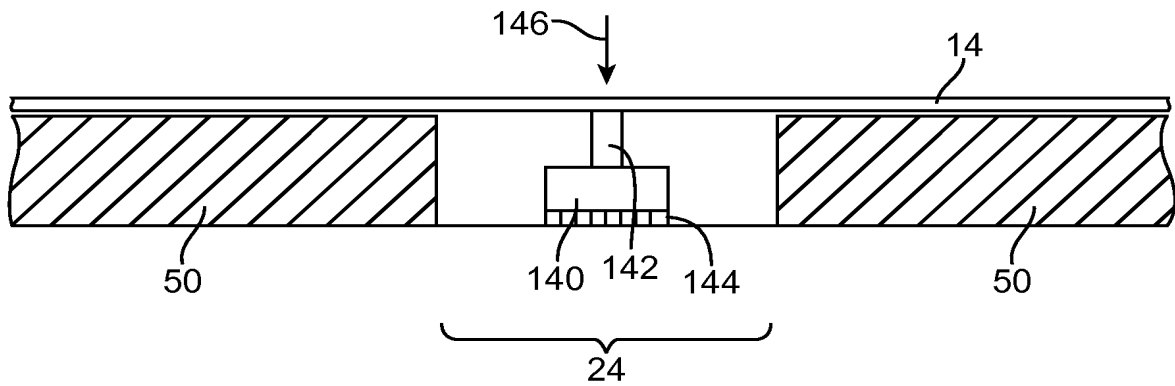

FIG. 16

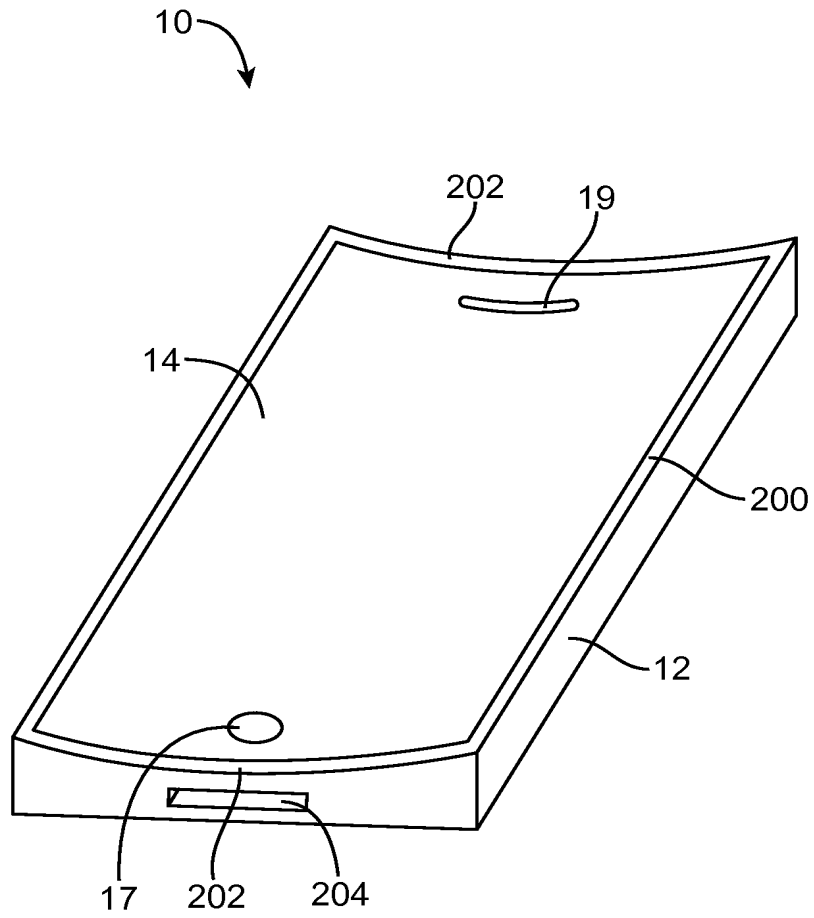

FIG. 17

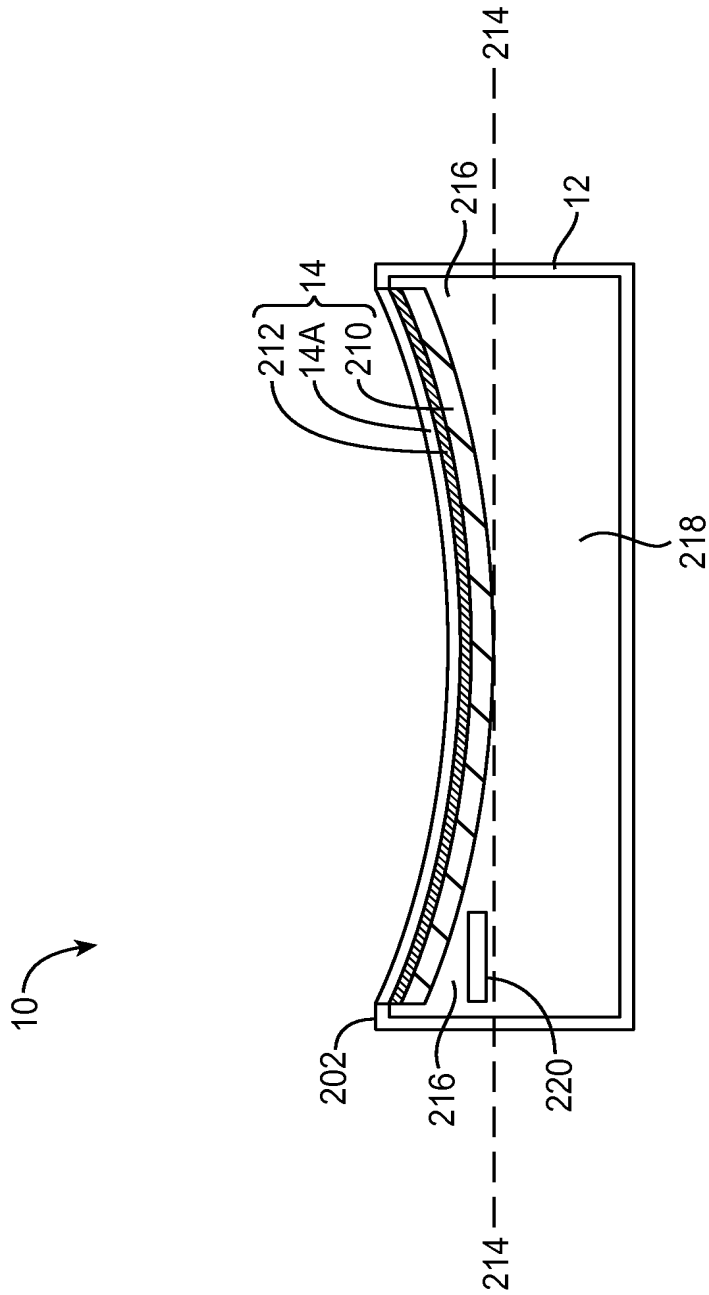

FIG. 18



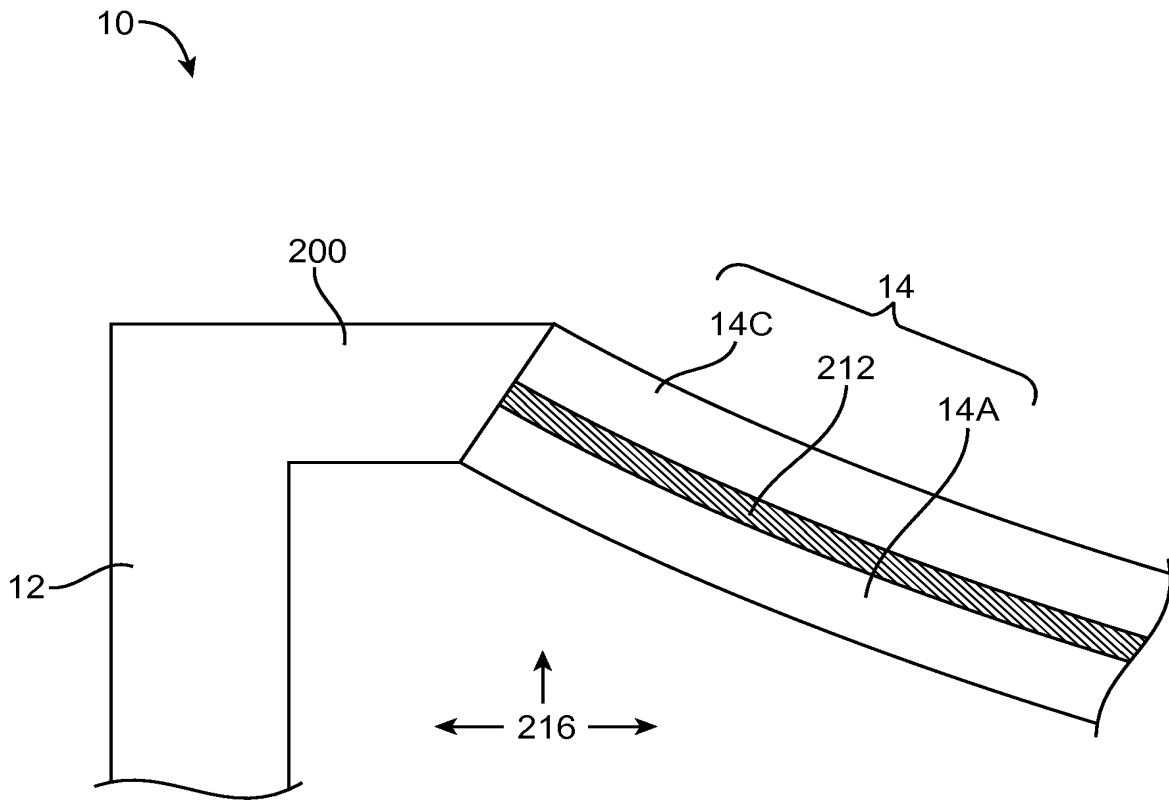

FIG. 19

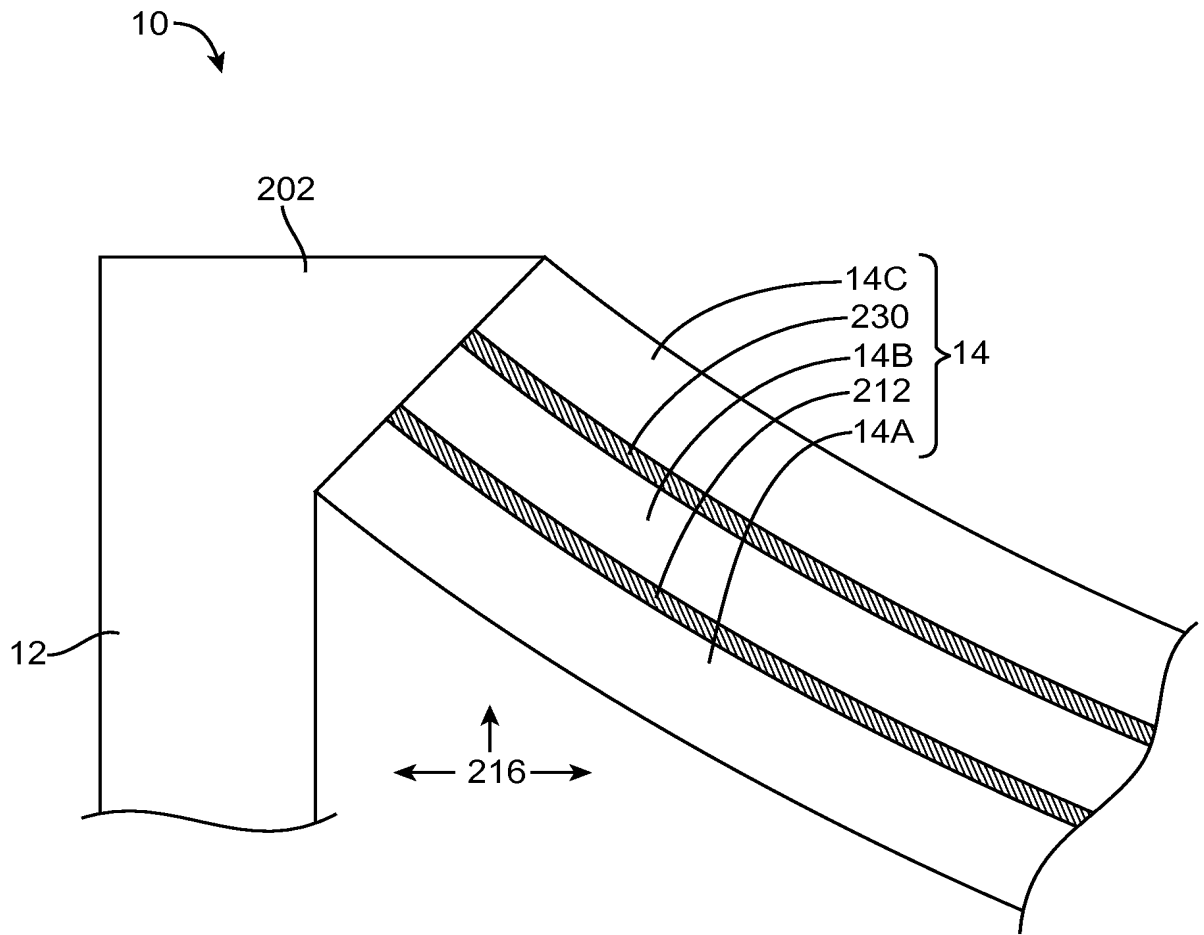

FIG. 20

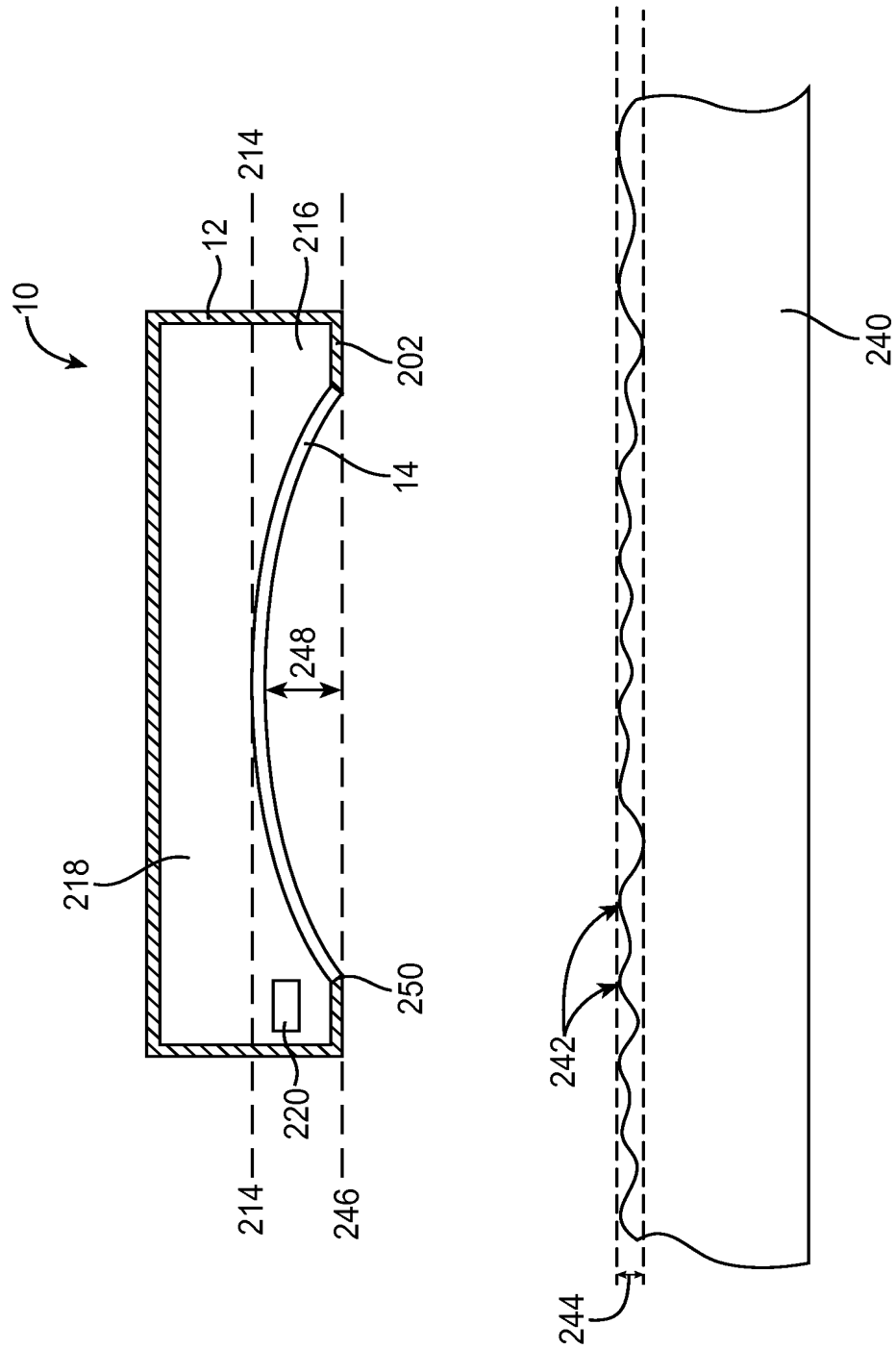

FIG. 21

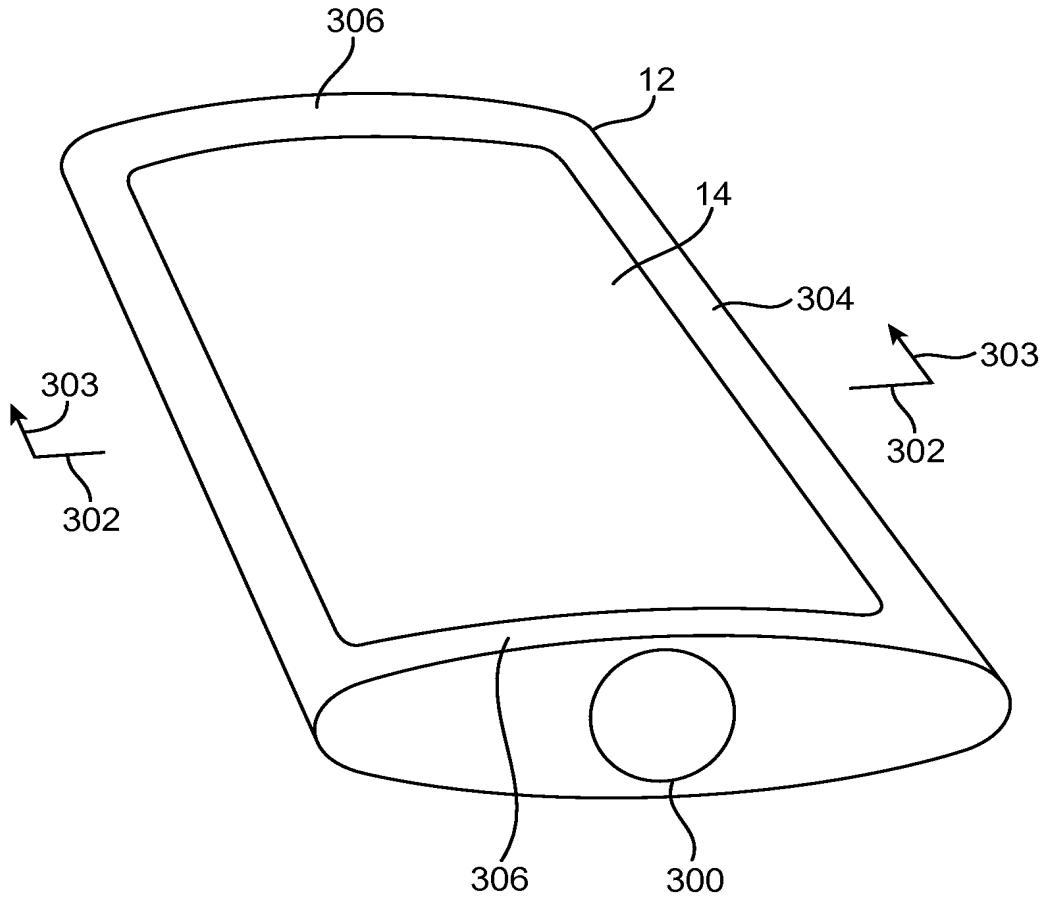

FIG. 22

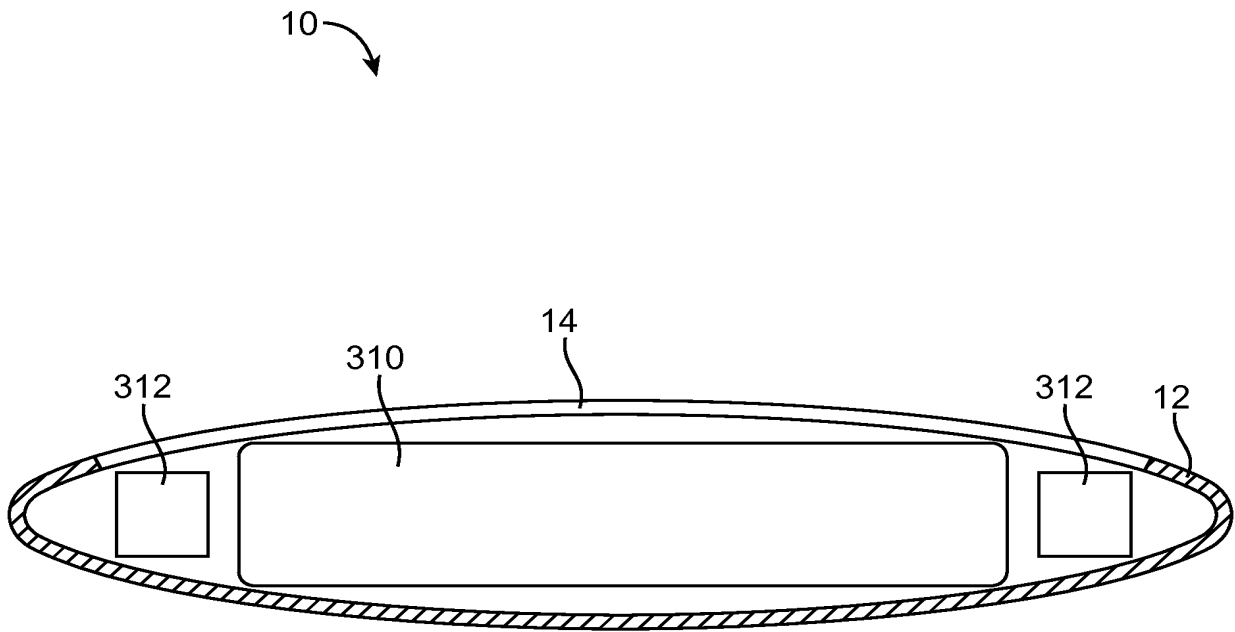

FIG. 23

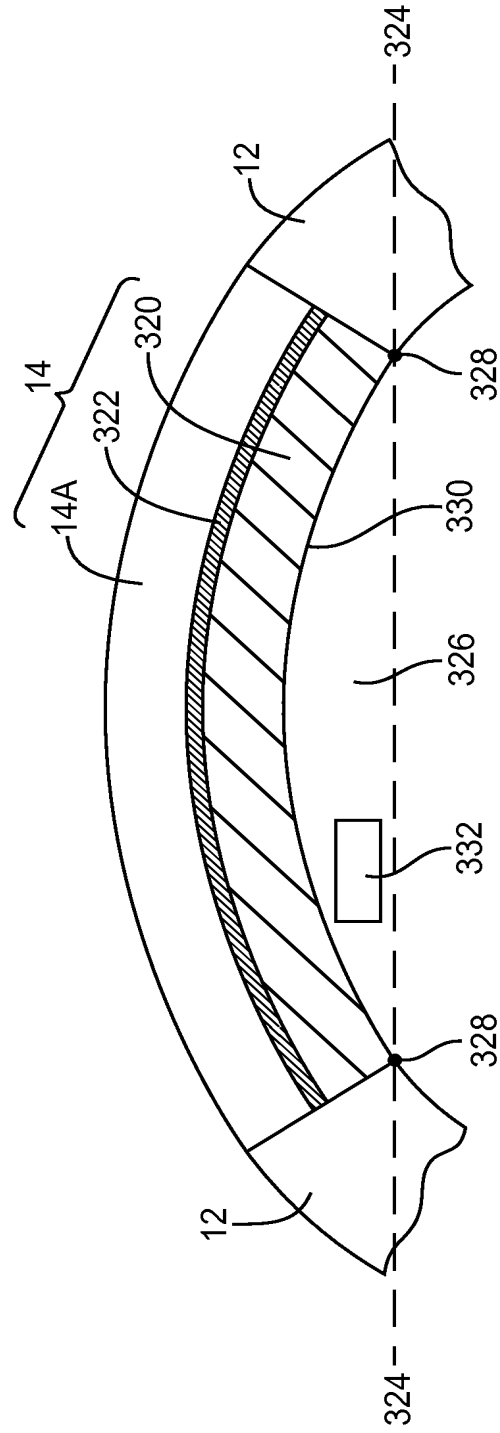

FIG. 24

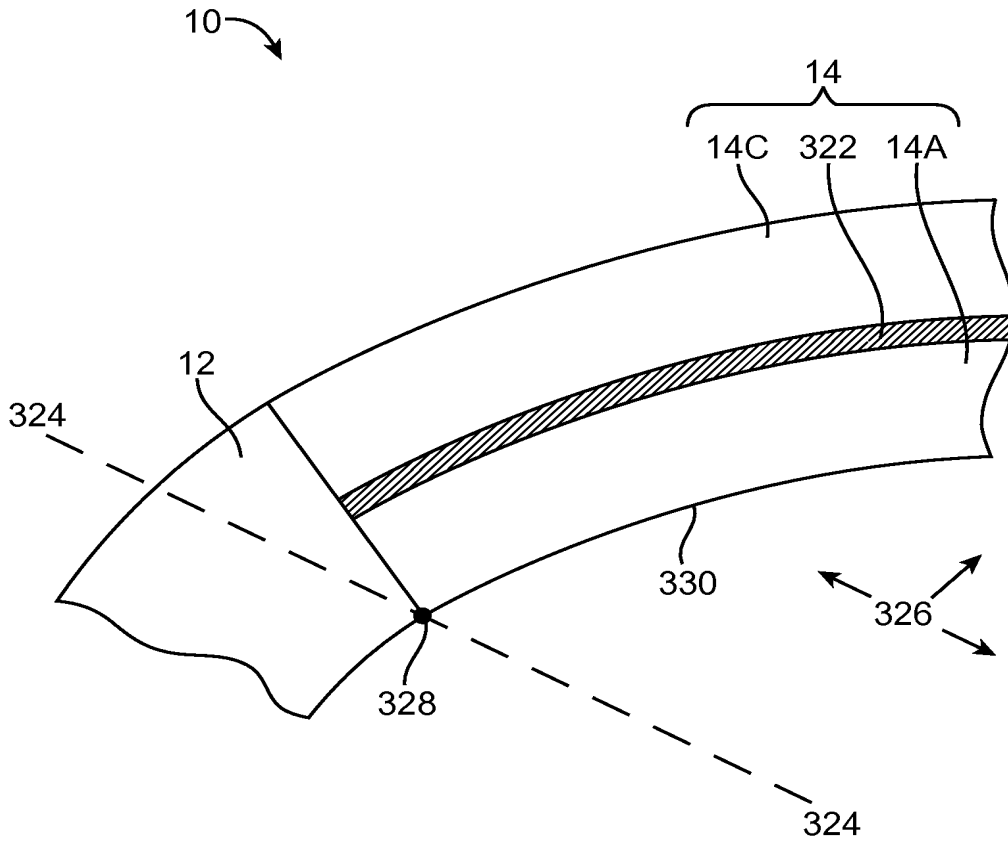

FIG. 25

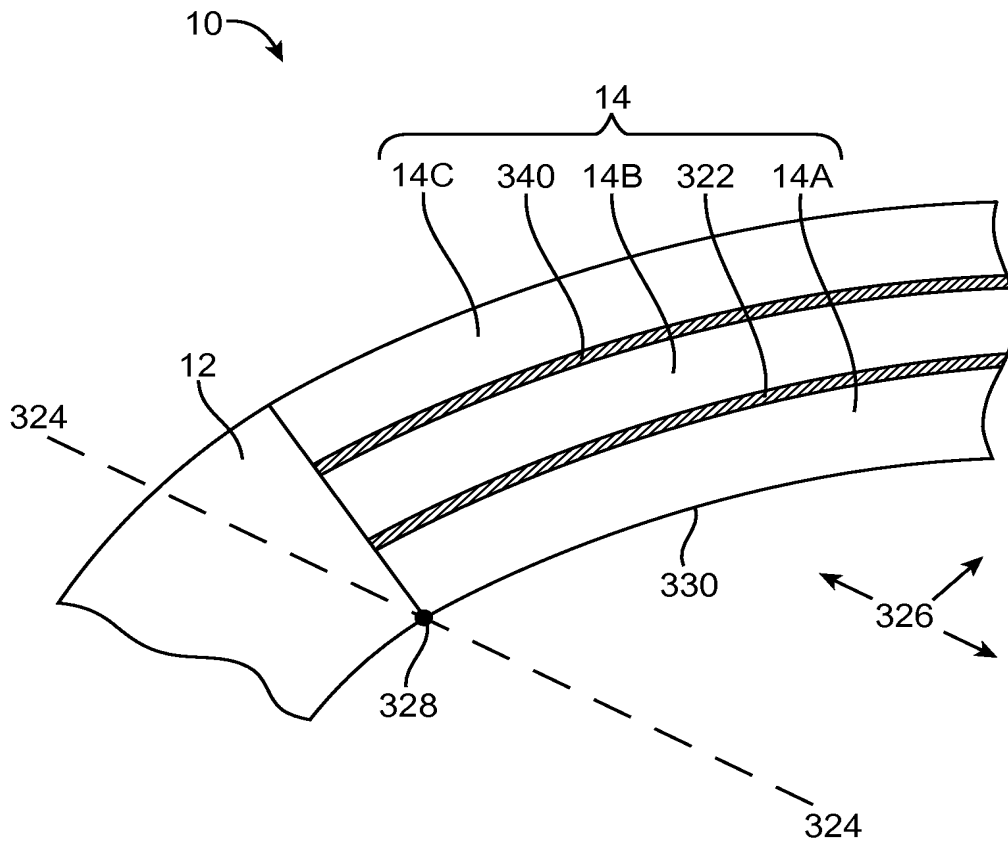

FIG. 26



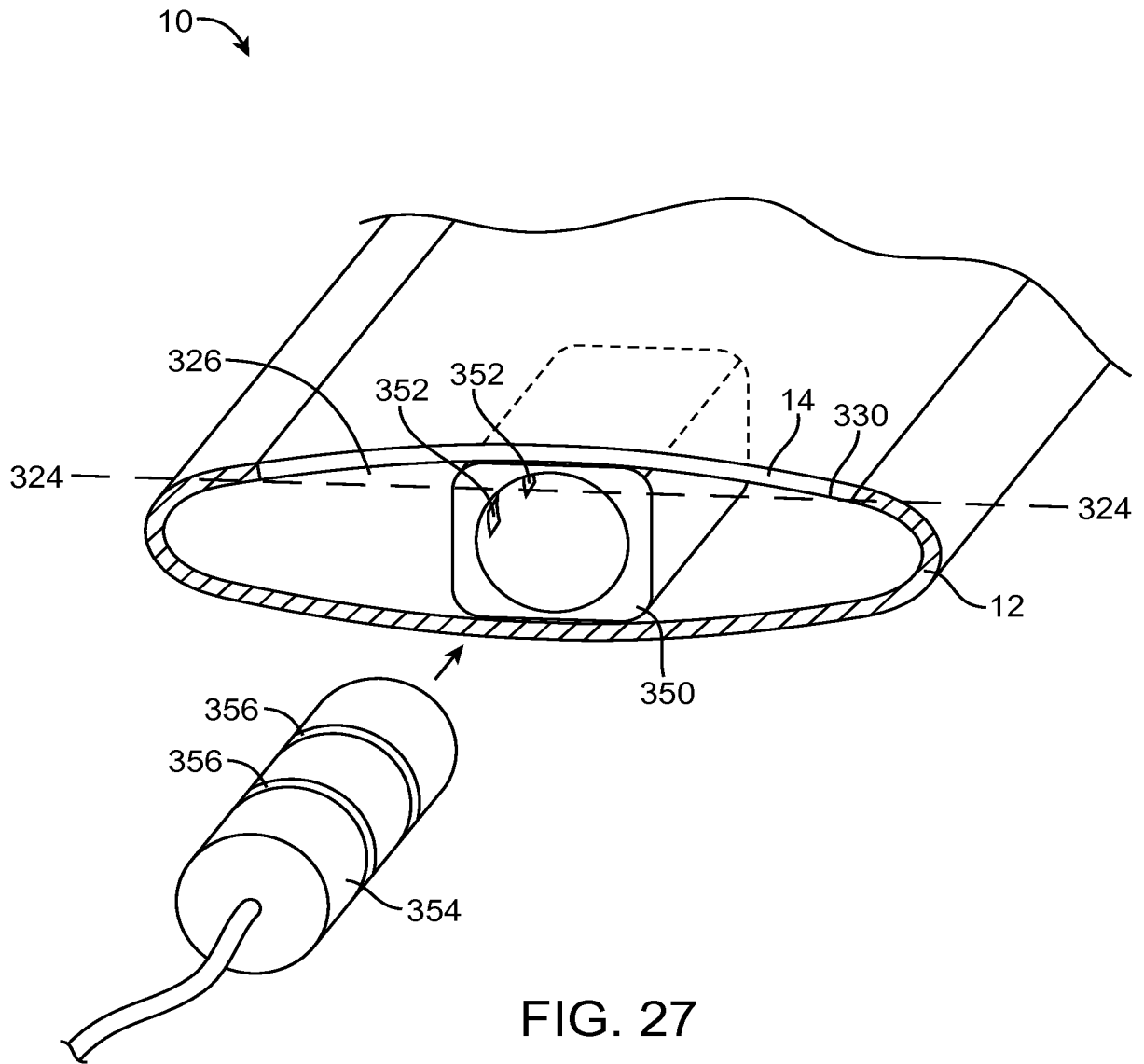

FIG. 27

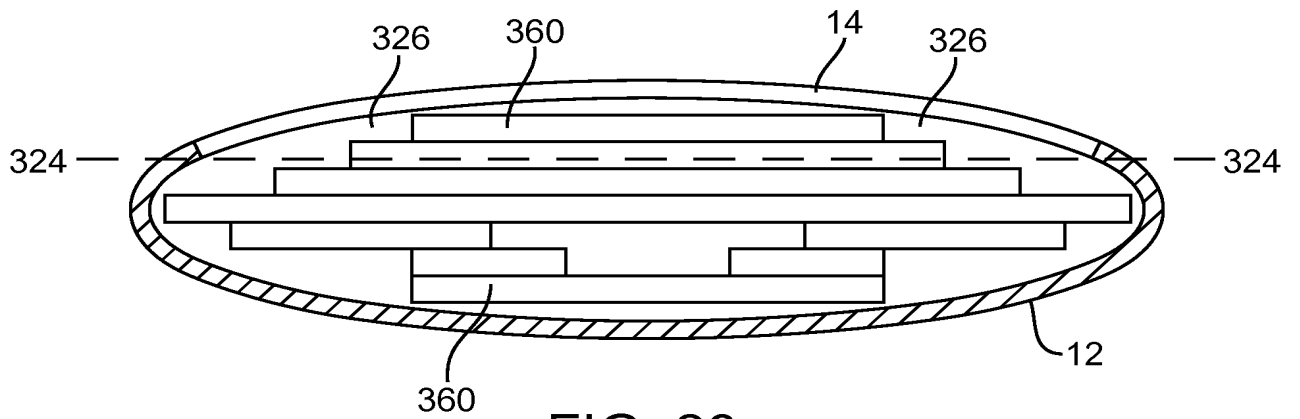

FIG. 28

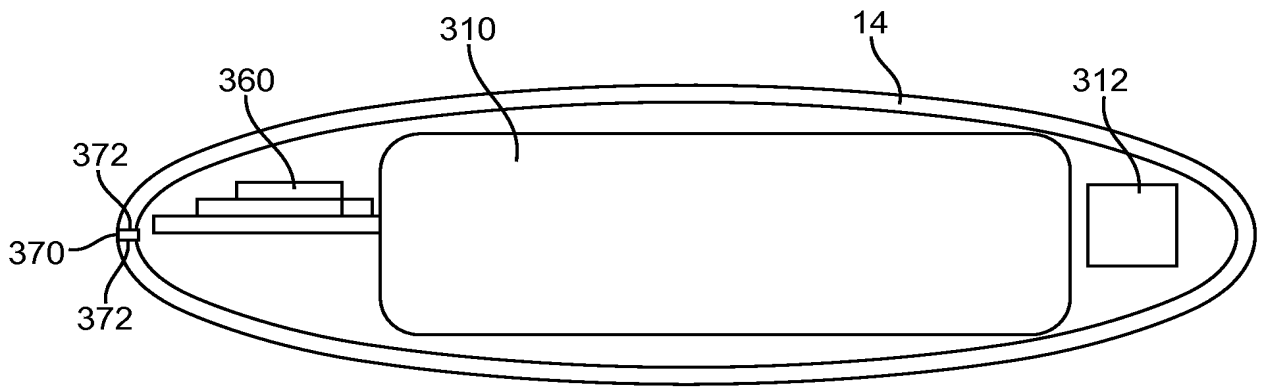

FIG. 29

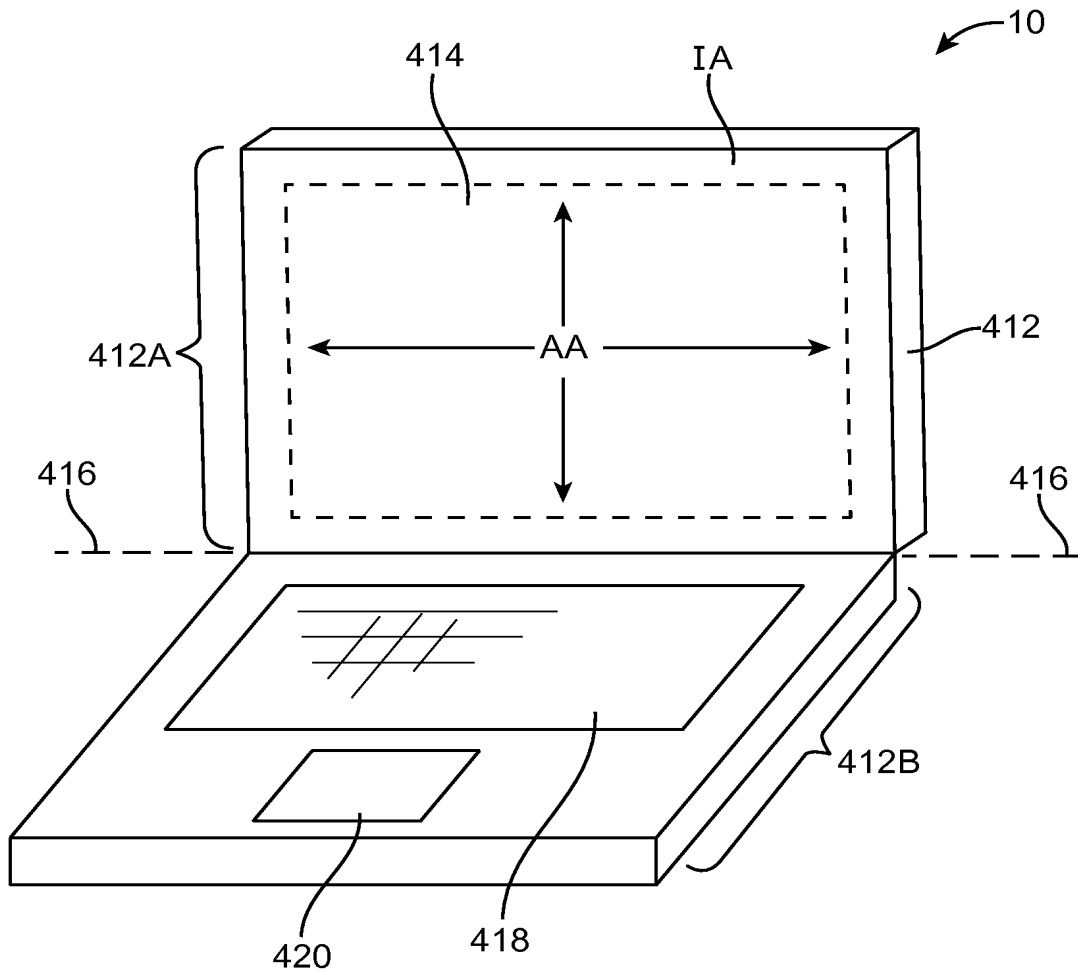

FIG. 30

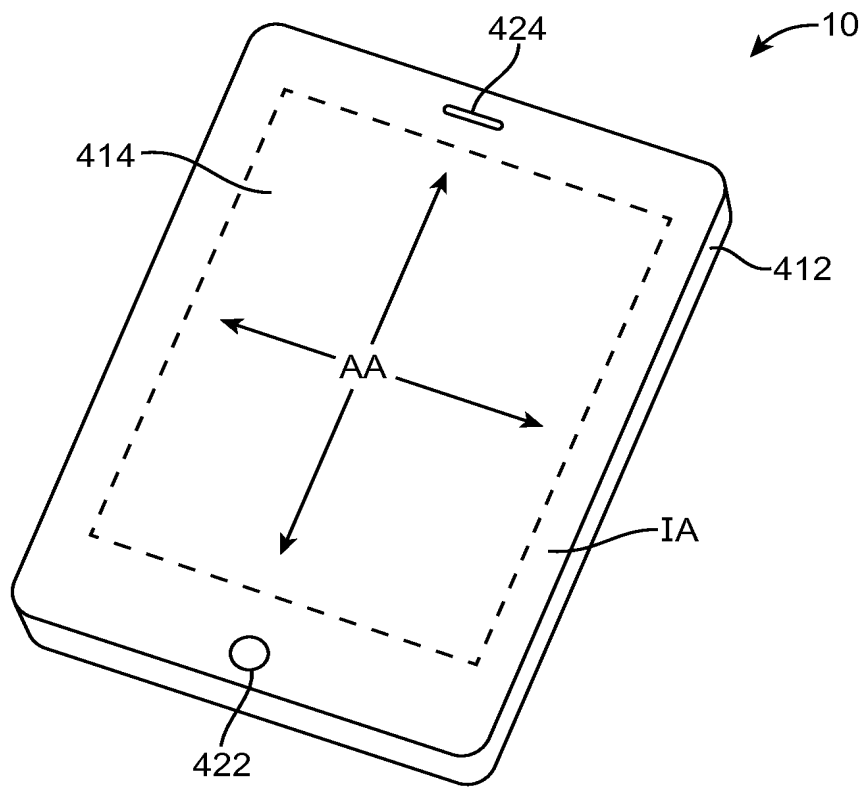

FIG. 31

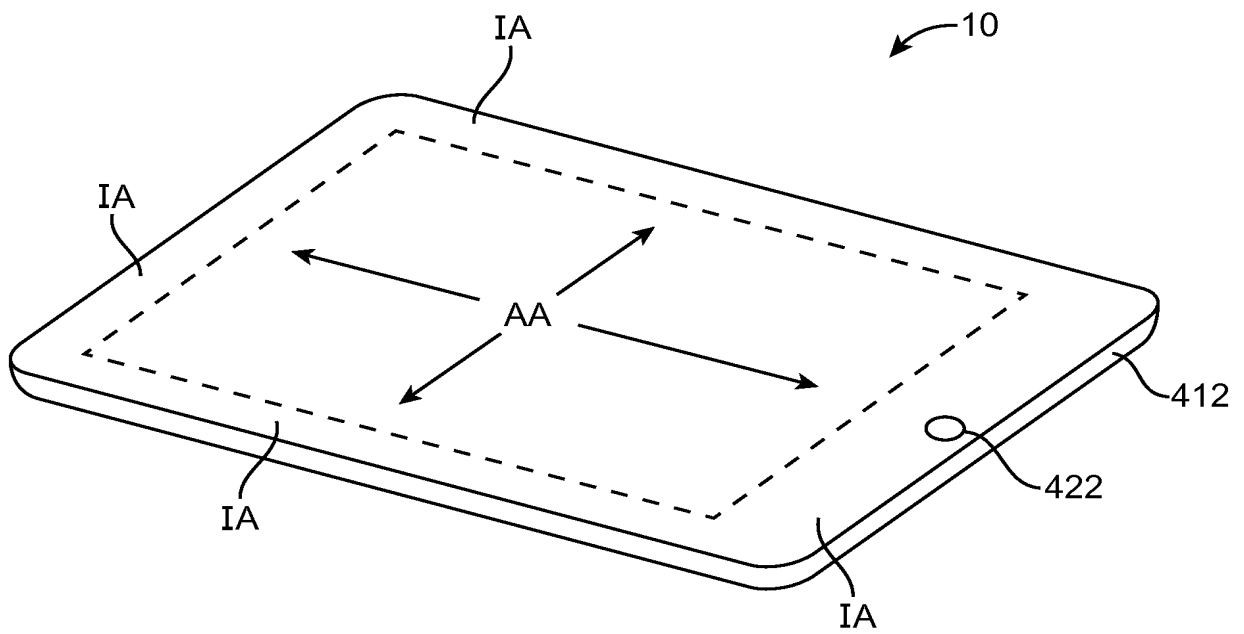

FIG. 32

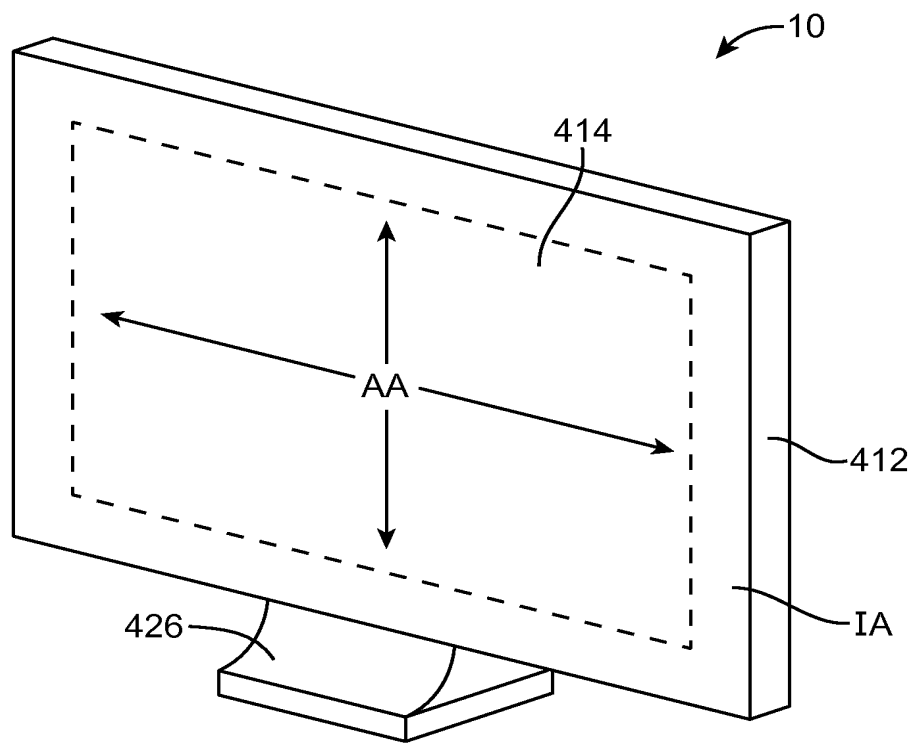

FIG. 33

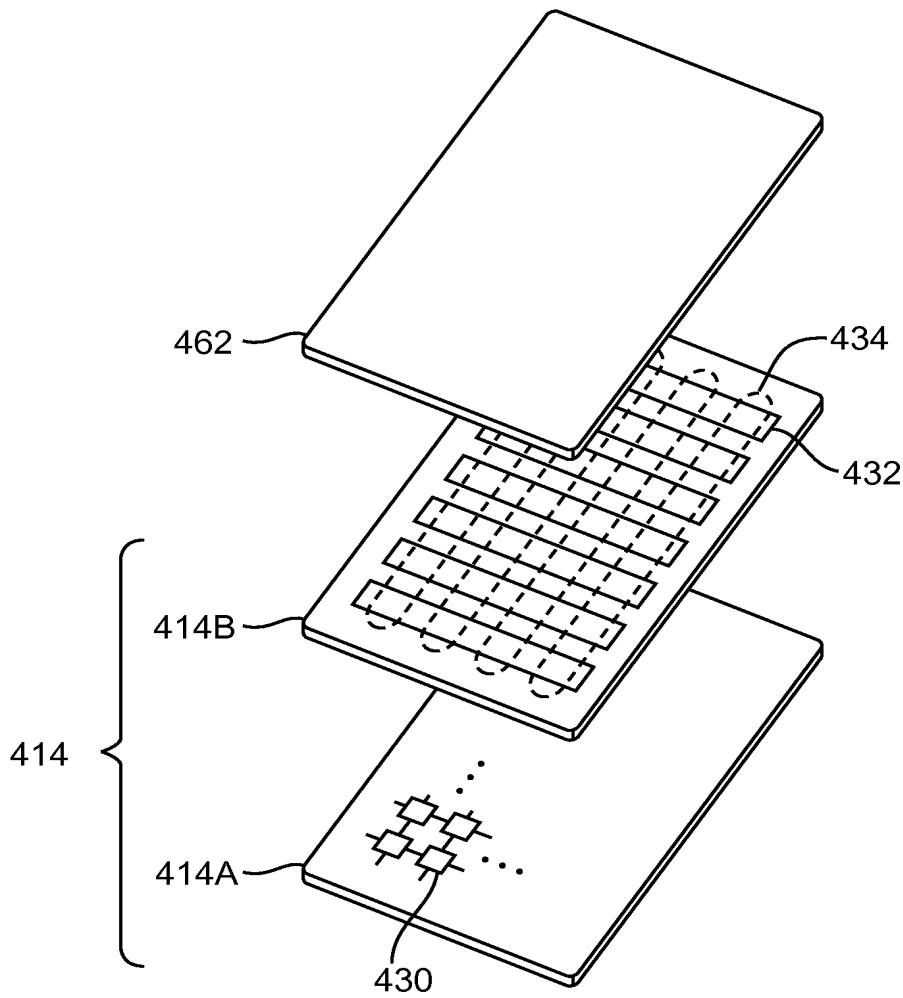

FIG. 34



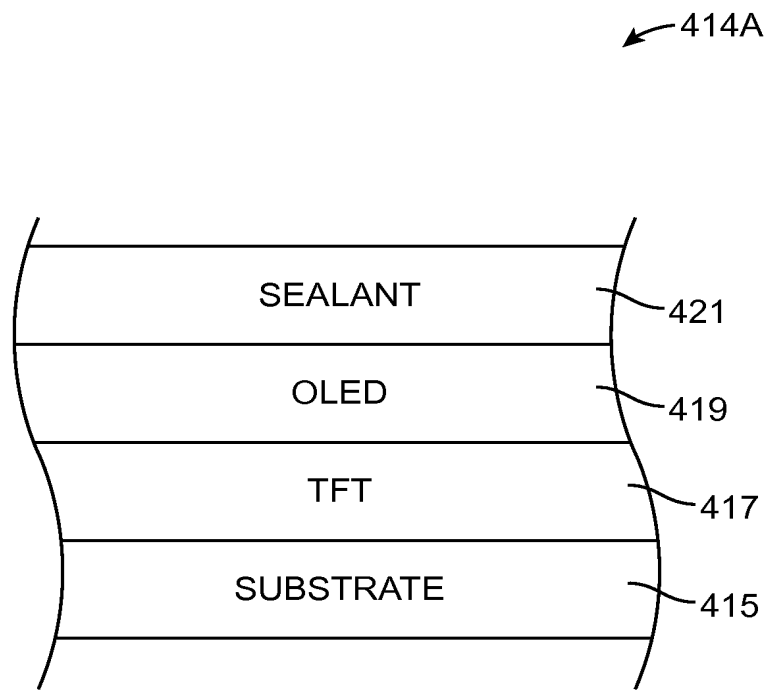

FIG. 35



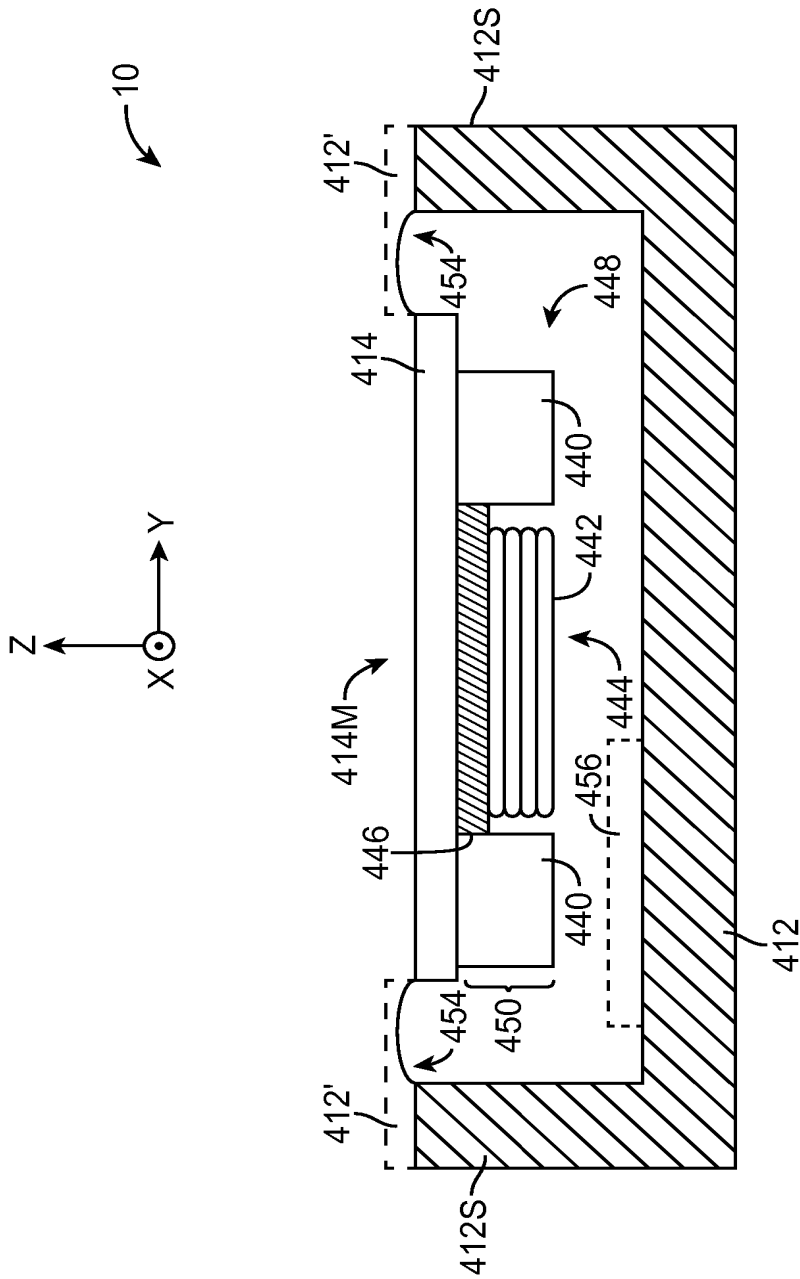

FIG. 37

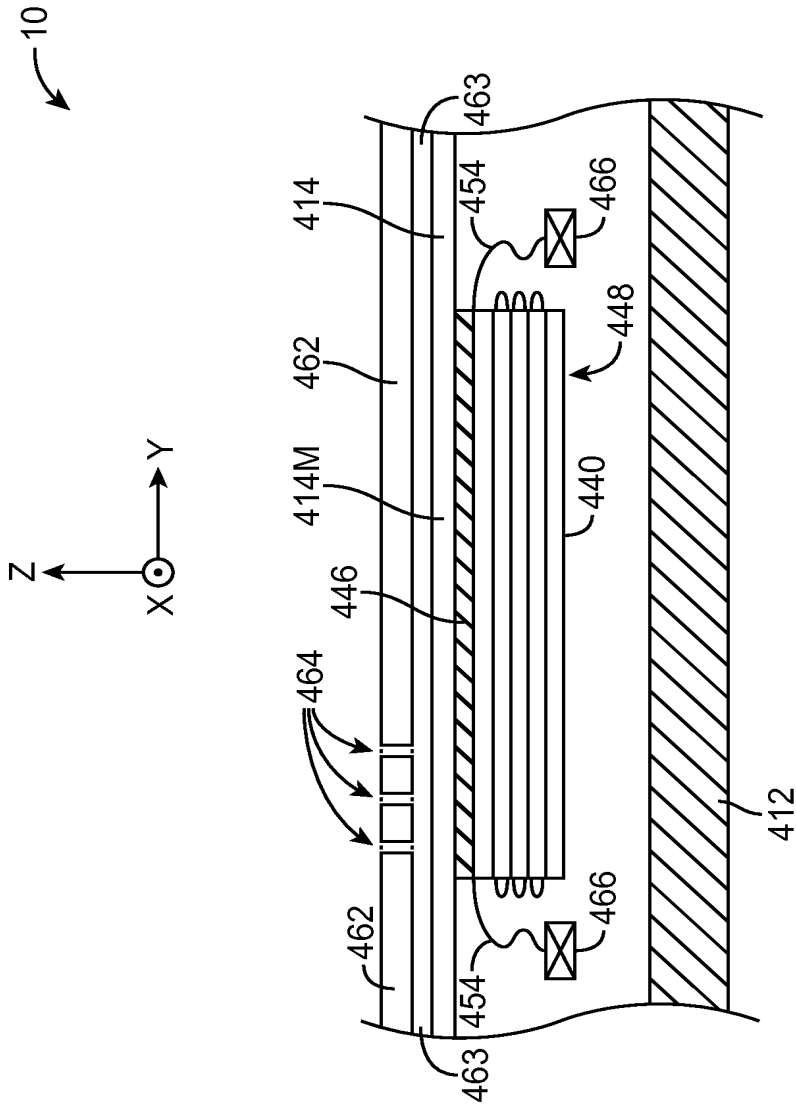

FIG. 38

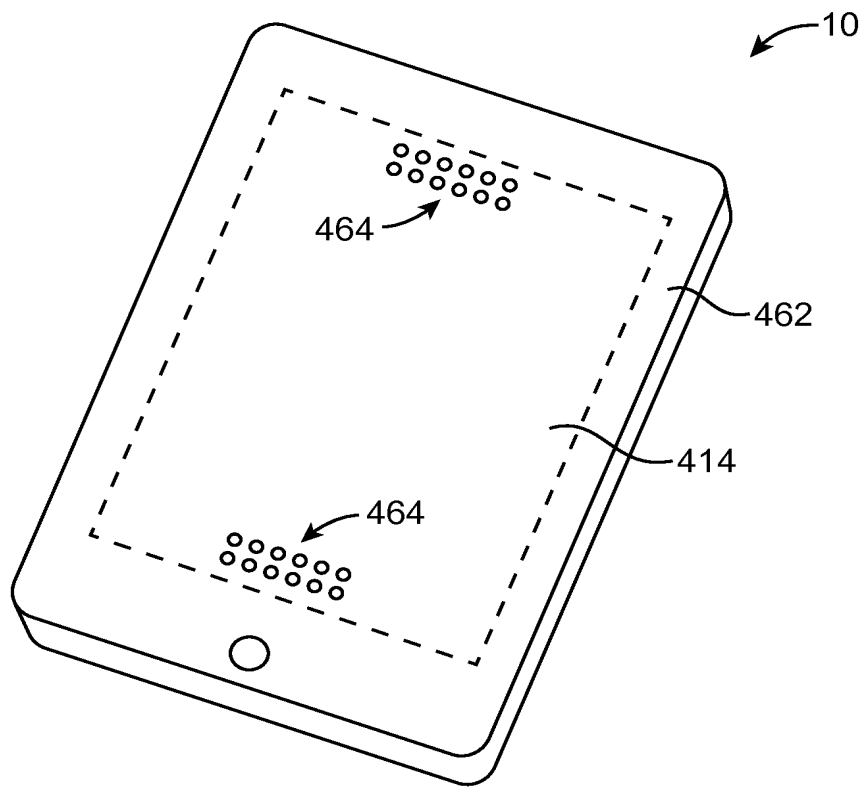

FIG. 39

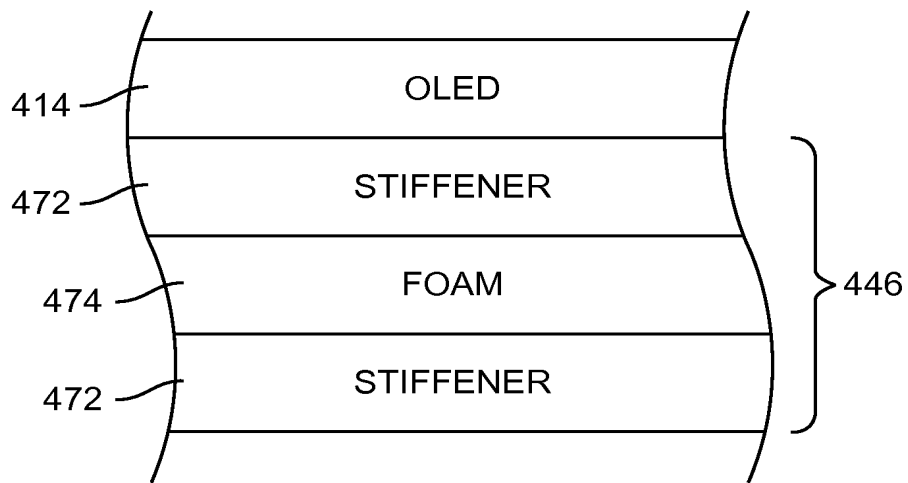

FIG. 40

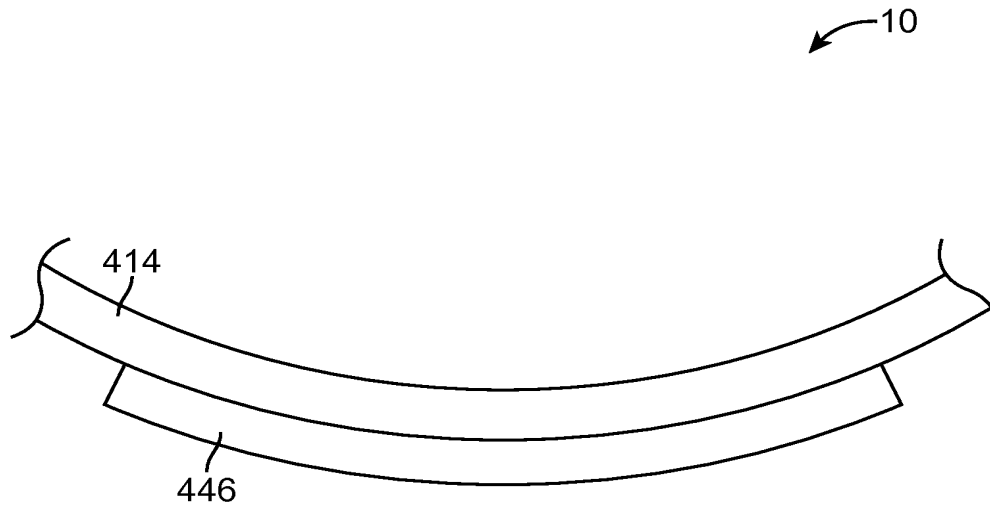

FIG. 41

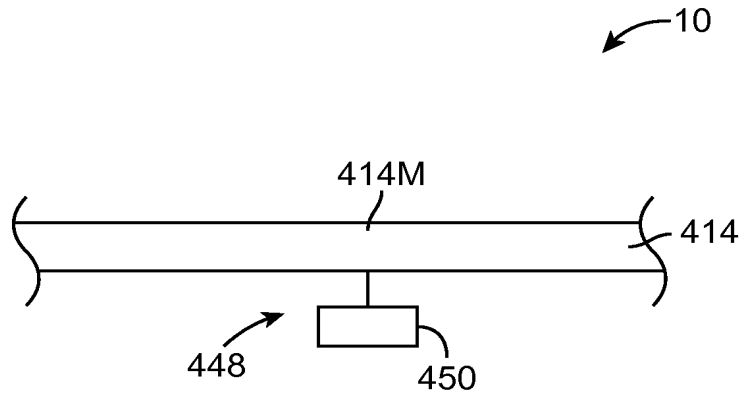

FIG. 42

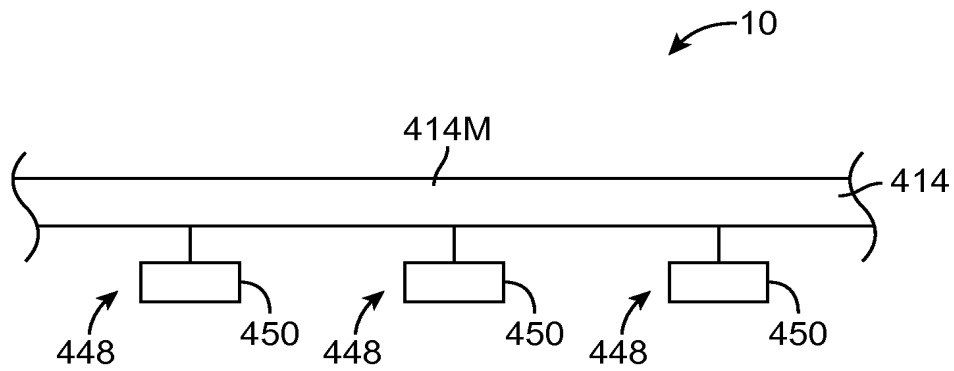

FIG. 43



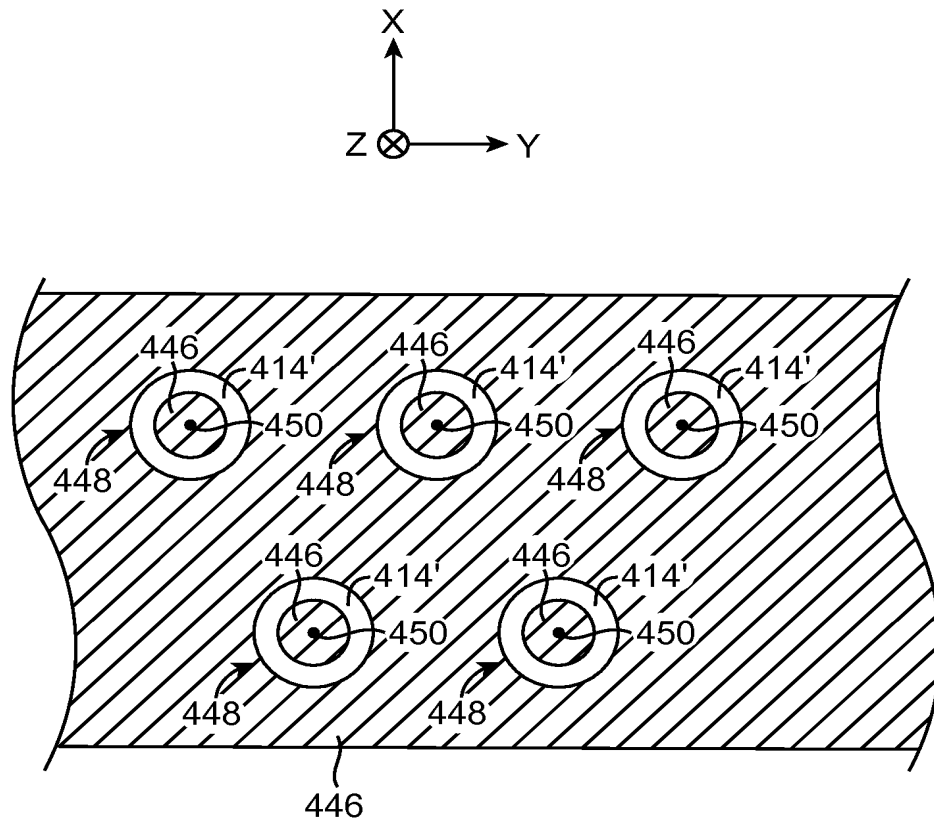

FIG. 44

## Electronic Acknowledgement Receipt

<b>EFS ID:</b>	15044401
<b>Application Number:</b>	13312405
<b>International Application Number:</b>	
<b>Confirmation Number:</b>	6025
<b>Title of Invention:</b>	Two-Layer Sensor Stack
<b>First Named Inventor/Applicant Name:</b>	David Brent Guard
<b>Customer Number:</b>	12323
<b>Filer:</b>	Russell Clayton Gee/Paula Hurley
<b>Filer Authorized By:</b>	Russell Clayton Gee
<b>Attorney Docket Number:</b>	080900.1371
<b>Receipt Date:</b>	25-FEB-2013
<b>Filing Date:</b>	06-DEC-2011
<b>Time Stamp:</b>	17:45:55
<b>Application Type:</b>	Utility under 35 USC 111(a)

### Payment information:

Submitted with Payment	no
------------------------	----

### File Listing:

Document Number	Document Description	File Name	File Size(Bytes)/ Message Digest	Multi Part /.zip	Pages (if appl.)
1	Transmittal Letter	IDS_080900_1371.pdf	64755 <small>0db82307a5dbd4e24461f4b45e42c314e67013df</small>	no	1

### Warnings:

### Information:

PETITIONERS

2	Information Disclosure Statement (IDS) Form (SB08)	SB08_080900_1371.pdf	76764	no	1
			c35a22892d85c1bda8a4453ee4c7829aeaa ae1d8		

**Warnings:**

**Information:**

This is not an USPTO supplied IDS fillable form

3	Foreign Reference	WO_2012_129247.pdf	4285007	no	142
			bc72f0894d8245fb68ef787739b6478d1890 b4b4		

**Warnings:**

**Information:**

<b>Total Files Size (in bytes):</b>	4426526
-------------------------------------	---------

**This Acknowledgement Receipt evidences receipt on the noted date by the USPTO of the indicated documents, characterized by the applicant, and including page counts, where applicable. It serves as evidence of receipt similar to a Post Card, as described in MPEP 503.**

**New Applications Under 35 U.S.C. 111**

**If a new application is being filed and the application includes the necessary components for a filing date (see 37 CFR 1.53(b)-(d) and MPEP 506), a Filing Receipt (37 CFR 1.54) will be issued in due course and the date shown on this Acknowledgement Receipt will establish the filing date of the application.**

**National Stage of an International Application under 35 U.S.C. 371**

**If a timely submission to enter the national stage of an international application is compliant with the conditions of 35 U.S.C. 371 and other applicable requirements a Form PCT/DO/EO/903 indicating acceptance of the application as a national stage submission under 35 U.S.C. 371 will be issued in addition to the Filing Receipt, in due course.**

**New International Application Filed with the USPTO as a Receiving Office**

**If a new international application is being filed and the international application includes the necessary components for an international filing date (see PCT Article 11 and MPEP 1810), a Notification of the International Application Number and of the International Filing Date (Form PCT/RO/105) will be issued in due course, subject to prescriptions concerning national security, and the date shown on this Acknowledgement Receipt will establish the international filing date of the application.**

IN THE UNITED STATES PATENT AND TRADEMARK OFFICE

First Named Inventor: David Brent Guard  
Application No.: 13/312405  
Filing Date: 6 December 2011  
Art Unit: 2833  
Confirmation No.: 6025  
Title: Two-Layer Sensor Stack

**Information Disclosure Statement**

Applicant submits this Information Disclosure Statement (IDS) under 37 C.F.R. § 1.97(b)(3). Applicant respectfully requests the Examiner to consider and cite in the examination of this Application the documents listed in the attached Form PTO/SB/08. Under 37 C.F.R. § 1.98(a)(2)(ii), Applicant has not provided copies of U.S. patents or U.S. patent application publications.

Under 37 C.F.R. § 1.97(g), the filing of this IDS shall not be construed as a representation that a search has been made. Moreover, under 37 C.F.R. § 1.97(h), the filing of this IDS shall not be construed to be an admission that the information cited in this IDS is or is considered to be material to patentability as defined by 37 C.F.R. §1.56(b). Furthermore, the filing of this IDS shall not be construed to be an admission that any information cited in this IDS is or is considered to be prior art under 35 U.S.C. §§ 102-103.

The Commissioner may charge any fee due and credit any overpayment in this Patent Application to Deposit Account No. 02-0384 of Baker Botts L.L.P.

Respectfully submitted,  
BAKER BOTTS L.L.P.  
Attorneys for Applicant

/Russell C. Gee/

Russell C. Gee  
Reg. No. 62,178

Date: 25 February 2013



UNITED STATES PATENT AND TRADEMARK OFFICE

UNITED STATES DEPARTMENT OF COMMERCE
United States Patent and Trademark Office
Address: COMMISSIONER FOR PATENTS
P.O. Box 1450
Alexandria, Virginia 22313-1450
www.uspto.gov

Table with 4 columns: APPLICATION NUMBER (13/312,405), FILING OR 371(C) DATE (12/06/2011), FIRST NAMED APPLICANT (David Brent Guard), ATTY. DOCKET NO./TITLE (080900.1371)

CONFIRMATION NO. 6025

PUBLICATION NOTICE

12323
Baker Botts L.L.P.
2001 Ross Avenue, 6th Floor
Dallas, TX 75201



Title: Two-Layer Sensor Stack

Publication No. US-2012-0261242-A1

Publication Date: 10/18/2012

NOTICE OF PUBLICATION OF APPLICATION

The above-identified application will be electronically published as a patent application publication pursuant to 37 CFR 1.211, et seq. The patent application publication number and publication date are set forth above.

The publication may be accessed through the USPTO's publically available Searchable Databases via the Internet at www.uspto.gov. The direct link to access the publication is currently http://www.uspto.gov/patft/.

The publication process established by the Office does not provide for mailing a copy of the publication to applicant. A copy of the publication may be obtained from the Office upon payment of the appropriate fee set forth in 37 CFR 1.19(a)(1). Orders for copies of patent application publications are handled by the USPTO's Office of Public Records. The Office of Public Records can be reached by telephone at (703) 308-9726 or (800) 972-6382, by facsimile at (703) 305-8759, by mail addressed to the United States Patent and Trademark Office, Office of Public Records, Alexandria, VA 22313-1450 or via the Internet.

In addition, information on the status of the application, including the mailing date of Office actions and the dates of receipt of correspondence filed in the Office, may also be accessed via the Internet through the Patent Electronic Business Center at www.uspto.gov using the public side of the Patent Application Information and Retrieval (PAIR) system. The direct link to access this status information is currently http://pair.uspto.gov/. Prior to publication, such status information is confidential and may only be obtained by applicant using the private side of PAIR.

Further assistance in electronically accessing the publication, or about PAIR, is available by calling the Patent Electronic Business Center at 1-866-217-9197.

Office of Data Management, Application Assistance Unit (571) 272-4000, or (571) 272-4200, or 1-888-786-0101



UNITED STATES PATENT AND TRADEMARK OFFICE

UNITED STATES DEPARTMENT OF COMMERCE
United States Patent and Trademark Office
Address: COMMISSIONER FOR PATENTS
P.O. Box 1450
Alexandria, Virginia 22313-1450
www.uspto.gov

Table with 7 columns: APPLICATION NUMBER, FILING or 371(c) DATE, GRP ART UNIT, FIL FEE REC'D, ATTY. DOCKET NO, TOT CLAIMS, IND CLAIMS. Row 1: 13/312,405, 12/06/2011, 2629, 1250, 080900.1371, 20, 3

CONFIRMATION NO. 6025

12323
Baker Botts L.L.P.
2001 Ross Avenue, 6th Floor
Dallas, TX 75201

FILING RECEIPT



Date Mailed: 12/21/2011

Receipt is acknowledged of this non-provisional patent application. The application will be taken up for examination in due course. Applicant will be notified as to the results of the examination. Any correspondence concerning the application must include the following identification information: the U.S. APPLICATION NUMBER, FILING DATE, NAME OF APPLICANT, and TITLE OF INVENTION. Fees transmitted by check or draft are subject to collection. Please verify the accuracy of the data presented on this receipt. If an error is noted on this Filing Receipt, please submit a written request for a Filing Receipt Correction. Please provide a copy of this Filing Receipt with the changes noted thereon. If you received a "Notice to File Missing Parts" for this application, please submit any corrections to this Filing Receipt with your reply to the Notice. When the USPTO processes the reply to the Notice, the USPTO will generate another Filing Receipt incorporating the requested corrections

Applicant(s)

David Brent Guard, Hampshire, UNITED KINGDOM;
Esat Yilmaz, Santa Cruz, CA;
Tsung-Ching Wu, Saratoga, CA;

Power of Attorney: None

Domestic Priority data as claimed by applicant

This application is a CON of 13/089,061 04/18/2011

Foreign Applications (You may be eligible to benefit from the Patent Prosecution Highway program at the USPTO. Please see http://www.uspto.gov for more information.)

If Required, Foreign Filing License Granted: 12/16/2011

The country code and number of your priority application, to be used for filing abroad under the Paris Convention, is US 13/312,405

Projected Publication Date: 10/18/2012

Non-Publication Request: No

Early Publication Request: No

**Title**

Two-Layer Sensor Stack

**Preliminary Class**

345

**PROTECTING YOUR INVENTION OUTSIDE THE UNITED STATES**

Since the rights granted by a U.S. patent extend only throughout the territory of the United States and have no effect in a foreign country, an inventor who wishes patent protection in another country must apply for a patent in a specific country or in regional patent offices. Applicants may wish to consider the filing of an international application under the Patent Cooperation Treaty (PCT). An international (PCT) application generally has the same effect as a regular national patent application in each PCT-member country. The PCT process **simplifies** the filing of patent applications on the same invention in member countries, but **does not result** in a grant of "an international patent" and does not eliminate the need of applicants to file additional documents and fees in countries where patent protection is desired.

Almost every country has its own patent law, and a person desiring a patent in a particular country must make an application for patent in that country in accordance with its particular laws. Since the laws of many countries differ in various respects from the patent law of the United States, applicants are advised to seek guidance from specific foreign countries to ensure that patent rights are not lost prematurely.

Applicants also are advised that in the case of inventions made in the United States, the Director of the USPTO must issue a license before applicants can apply for a patent in a foreign country. The filing of a U.S. patent application serves as a request for a foreign filing license. The application's filing receipt contains further information and guidance as to the status of applicant's license for foreign filing.

Applicants may wish to consult the USPTO booklet, "General Information Concerning Patents" (specifically, the section entitled "Treaties and Foreign Patents") for more information on timeframes and deadlines for filing foreign patent applications. The guide is available either by contacting the USPTO Contact Center at 800-786-9199, or it can be viewed on the USPTO website at <http://www.uspto.gov/web/offices/pac/doc/general/index.html>.

For information on preventing theft of your intellectual property (patents, trademarks and copyrights), you may wish to consult the U.S. Government website, <http://www.stopfakes.gov>. Part of a Department of Commerce initiative, this website includes self-help "toolkits" giving innovators guidance on how to protect intellectual property in specific countries such as China, Korea and Mexico. For questions regarding patent enforcement issues, applicants may call the U.S. Government hotline at 1-866-999-HALT (1-866-999-4158).

**LICENSE FOR FOREIGN FILING UNDER**

**Title 35, United States Code, Section 184**

**Title 37, Code of Federal Regulations, 5.11 & 5.15**

**GRANTED**

The applicant has been granted a license under 35 U.S.C. 184, if the phrase "IF REQUIRED, FOREIGN FILING LICENSE GRANTED" followed by a date appears on this form. Such licenses are issued in all applications where the conditions for issuance of a license have been met, regardless of whether or not a license may be required as

set forth in 37 CFR 5.15. The scope and limitations of this license are set forth in 37 CFR 5.15(a) unless an earlier license has been issued under 37 CFR 5.15(b). The license is subject to revocation upon written notification. The date indicated is the effective date of the license, unless an earlier license of similar scope has been granted under 37 CFR 5.13 or 5.14.

This license is to be retained by the licensee and may be used at any time on or after the effective date thereof unless it is revoked. This license is automatically transferred to any related applications(s) filed under 37 CFR 1.53(d). This license is not retroactive.

The grant of a license does not in any way lessen the responsibility of a licensee for the security of the subject matter as imposed by any Government contract or the provisions of existing laws relating to espionage and the national security or the export of technical data. Licensees should apprise themselves of current regulations especially with respect to certain countries, of other agencies, particularly the Office of Defense Trade Controls, Department of State (with respect to Arms, Munitions and Implements of War (22 CFR 121-128)); the Bureau of Industry and Security, Department of Commerce (15 CFR parts 730-774); the Office of Foreign Assets Control, Department of Treasury (31 CFR Parts 500+) and the Department of Energy.

#### **NOT GRANTED**

No license under 35 U.S.C. 184 has been granted at this time, if the phrase "IF REQUIRED, FOREIGN FILING LICENSE GRANTED" DOES NOT appear on this form. Applicant may still petition for a license under 37 CFR 5.12, if a license is desired before the expiration of 6 months from the filing date of the application. If 6 months has lapsed from the filing date of this application and the licensee has not received any indication of a secrecy order under 35 U.S.C. 181, the licensee may foreign file the application pursuant to 37 CFR 5.15(b).

---

### ***SelectUSA***

The United States represents the largest, most dynamic marketplace in the world and is an unparalleled location for business investment, innovation and commercialization of new technologies. The USA offers tremendous resources and advantages for those who invest and manufacture goods here. Through SelectUSA, our nation works to encourage, facilitate, and accelerate business investment. To learn more about why the USA is the best country in the world to develop technology, manufacture products, and grow your business, visit [SelectUSA.gov](http://SelectUSA.gov).



**PATENT APPLICATION FEE DETERMINATION RECORD**

Substitute for Form PTO-875

Application or Docket Number  
13/312,405

**APPLICATION AS FILED - PART I**

(Column 1) (Column 2)

FOR	NUMBER FILED	NUMBER EXTRA
BASIC FEE (37 CFR 1.16(a), (b), or (c))	N/A	N/A
SEARCH FEE (37 CFR 1.16(k), (l), or (m))	N/A	N/A
EXAMINATION FEE (37 CFR 1.16(o), (p), or (q))	N/A	N/A
TOTAL CLAIMS (37 CFR 1.16(j))	20	minus 20 = *
INDEPENDENT CLAIMS (37 CFR 1.16(h))	3	minus 3 = *
APPLICATION SIZE FEE (37 CFR 1.16(s))	If the specification and drawings exceed 100 sheets of paper, the application size fee due is \$310 (\$155 for small entity) for each additional 50 sheets or fraction thereof. See 35 U.S.C. 41(a)(1)(G) and 37 CFR 1.16(s).	
MULTIPLE DEPENDENT CLAIM PRESENT (37 CFR 1.16(j))		

**SMALL ENTITY**

RATE(\$)	FEE(\$)
N/A	
N/A	
N/A	
TOTAL	

**OR OTHER THAN SMALL ENTITY**

RATE(\$)	FEE(\$)
N/A	380
N/A	620
N/A	250
x 60 =	0.00
x 250 =	0.00
	0.00
	0.00
TOTAL	1250

\* If the difference in column 1 is less than zero, enter "0" in column 2.

**APPLICATION AS AMENDED - PART II**

(Column 1) (Column 2) (Column 3)

AMENDMENT A		CLAIMS REMAINING AFTER AMENDMENT		HIGHEST NUMBER PREVIOUSLY PAID FOR	PRESENT EXTRA
	Total (37 CFR 1.16(j))	*	Minus	**	=
Independent (37 CFR 1.16(h))	*	Minus	***	=	
Application Size Fee (37 CFR 1.16(s))					
FIRST PRESENTATION OF MULTIPLE DEPENDENT CLAIM (37 CFR 1.16(j))					

**SMALL ENTITY**

RATE(\$)	ADDITIONAL FEE(\$)
x =	
x =	
TOTAL ADD'L FEE	

**OR OTHER THAN SMALL ENTITY**

RATE(\$)	ADDITIONAL FEE(\$)
x =	
x =	
TOTAL ADD'L FEE	

(Column 1) (Column 2) (Column 3)

AMENDMENT B		CLAIMS REMAINING AFTER AMENDMENT		HIGHEST NUMBER PREVIOUSLY PAID FOR	PRESENT EXTRA
	Total (37 CFR 1.16(j))	*	Minus	**	=
Independent (37 CFR 1.16(h))	*	Minus	***	=	
Application Size Fee (37 CFR 1.16(s))					
FIRST PRESENTATION OF MULTIPLE DEPENDENT CLAIM (37 CFR 1.16(j))					

**SMALL ENTITY**

RATE(\$)	ADDITIONAL FEE(\$)
x =	
x =	
TOTAL ADD'L FEE	

**OR OTHER THAN SMALL ENTITY**

RATE(\$)	ADDITIONAL FEE(\$)
x =	
x =	
TOTAL ADD'L FEE	

\* If the entry in column 1 is less than the entry in column 2, write "0" in column 3.

\*\* If the "Highest Number Previously Paid For" IN THIS SPACE is less than 20, enter "20".

\*\*\* If the "Highest Number Previously Paid For" IN THIS SPACE is less than 3, enter "3".

The "Highest Number Previously Paid For" (Total or Independent) is the highest found in the appropriate box in column 1.

PTO/SB/08  <b>INFORMATION DISCLOSURE STATEMENT BY APPLICANT</b>	<b>Application Number:</b> Unassigned		<b>First Named Inventor:</b> David Brent Guard	
	<b>Attorney Docket No:</b> 080900.1371	<b>Art Unit:</b> Unassigned		<b>Filing Date:</b> Herewith

**ISSUED U.S. PATENTS AND PUBLISHED U.S. APPLICATIONS**

	DOCUMENT NUMBER	PUBLICATION OR ISSUE DATE	FIRST NAMED INVENTOR
A	7,663,607	02-16-2010	Hotelling
B	7,920,129	04-05-2011	Hotelling
C	8,031,094	10-04-2011	Hotelling
D	8,031,174	10-04-2011	Hamblin
E	8,049,732	11-01-2011	Hotelling

**UNPUBLISHED U.S. APPLICATIONS**

	DOCUMENT NUMBER	FILING DATE	FIRST NAMED INVENTOR
F			
G			
H			
I			

**FOREIGN PATENT DOCUMENTS**

	DOCUMENT NUMBER	PUBLICATION OR ISSUE DATE	COUNTRY	TRANSLATION (YES OR NO)
J				
K				

**NON-PATENT LITERATURE (NPL)**

	DOCUMENT (Including Author, Title, Source, and Pertinent Pages)	DATE
L		
M		
N		
O		
P		
Q		

EXAMINER	DATE CONSIDERED
EXAMINER: Initial if citation considered, whether or not citation is in conformance with MPEP § 609. Draw line through citation if not in conformance and not considered. Include copy of this form with next communication to the applicant.	

## Electronic Patent Application Fee Transmittal

<b>Application Number:</b>	
<b>Filing Date:</b>	
<b>Title of Invention:</b>	Two-Layer Sensor Stack
<b>First Named Inventor/Applicant Name:</b>	David Brent Guard
<b>Filer:</b>	Travis W. Thomas/Jennifer Gross
<b>Attorney Docket Number:</b>	080900.1371

Filed as Large Entity

### Utility under 35 USC 111(a) Filing Fees

Description	Fee Code	Quantity	Amount	Sub-Total in USD(\$)
<b>Basic Filing:</b>				
Utility application filing	1011	1	380	380
Utility Search Fee	1111	1	620	620
Utility Examination Fee	1311	1	250	250

**Pages:**

**Claims:**

**Miscellaneous-Filing:**

**Petition:**

**Patent-Appeals-and-Interference:**

PETITIONERS

Description	Fee Code	Quantity	Amount	Sub-Total in USD(\$)
<b>Post-Allowance-and-Post-Issuance:</b>				
<b>Extension-of-Time:</b>				
<b>Miscellaneous:</b>				
<b>Total in USD (\$)</b>				<b>1250</b>

## Electronic Acknowledgement Receipt

<b>EFS ID:</b>	11554014
<b>Application Number:</b>	13312405
<b>International Application Number:</b>	
<b>Confirmation Number:</b>	6025
<b>Title of Invention:</b>	Two-Layer Sensor Stack
<b>First Named Inventor/Applicant Name:</b>	David Brent Guard
<b>Customer Number:</b>	12323
<b>Filer:</b>	Travis W. Thomas/Jennifer Gross
<b>Filer Authorized By:</b>	Travis W. Thomas
<b>Attorney Docket Number:</b>	080900.1371
<b>Receipt Date:</b>	06-DEC-2011
<b>Filing Date:</b>	
<b>Time Stamp:</b>	16:15:35
<b>Application Type:</b>	Utility under 35 USC 111(a)

### Payment information:

Submitted with Payment	yes
Payment Type	Deposit Account
Payment was successfully received in RAM	\$1250
RAM confirmation Number	3574
Deposit Account	020384
Authorized User	

### File Listing:

Document Number	Document Description	File Name	File Size(Bytes)/ Message Digest	Multi Part /zip (if appl.)	Pages (if appl.)
-----------------	----------------------	-----------	-------------------------------------	----------------------------	------------------

1	Application Data Sheet	Application_Data_Sheet_for_080900_1371.pdf	41657 6d761340ca7690c958eafbc024f3049deceb3dd	no	5
<b>Warnings:</b>					
<b>Information:</b>					
This is not an USPTO supplied ADS fillable form					
2		Application_for_080900_1371.pdf	1139176 51d24ab271fff4d4dac4c5fe23be3b9eff2b7445	yes	25
	<b>Multipart Description/PDF files in .zip description</b>				
	<b>Document Description</b>		<b>Start</b>	<b>End</b>	
	Specification		1	21	
	Claims		22	24	
	Abstract		25	25	
<b>Warnings:</b>					
<b>Information:</b>					
3	Drawings-only black and white line drawings	Figures_for_080900_1371.pdf	182527 6f188749c6ab198d3146a33a633238d292fb60d3	no	9
<b>Warnings:</b>					
<b>Information:</b>					
4	Oath or Declaration filed	Declaration_for_080900_1371.pdf	147897 01aa1673bc47edb749570421371cd6a19d8c3e54	no	2
<b>Warnings:</b>					
<b>Information:</b>					
5	Information Disclosure Statement (IDS) Form (SB08)	IDS_SB08_with_APP_for_080900_1371.pdf	75466 0a75a20ca485c2f1318fd27be960ce7a684d46f	no	1
<b>Warnings:</b>					
<b>Information:</b>					
This is not an USPTO supplied IDS fillable form					
6	Fee Worksheet (SB06)	fee-info.pdf	32729 8feabe9edc6d7c644b8ded5cf1c5412c8438ce07	no	2
<b>Warnings:</b>					
<b>Information:</b>					
<b>Total Files Size (in bytes):</b>			1619452		

**This Acknowledgement Receipt evidences receipt on the noted date by the USPTO of the indicated documents, characterized by the applicant, and including page counts, where applicable. It serves as evidence of receipt similar to a Post Card, as described in MPEP 503.**

**New Applications Under 35 U.S.C. 111**

**If a new application is being filed and the application includes the necessary components for a filing date (see 37 CFR 1.53(b)-(d) and MPEP 506), a Filing Receipt (37 CFR 1.54) will be issued in due course and the date shown on this Acknowledgement Receipt will establish the filing date of the application.**

**National Stage of an International Application under 35 U.S.C. 371**

**If a timely submission to enter the national stage of an international application is compliant with the conditions of 35 U.S.C. 371 and other applicable requirements a Form PCT/DO/EO/903 indicating acceptance of the application as a national stage submission under 35 U.S.C. 371 will be issued in addition to the Filing Receipt, in due course.**

**New International Application Filed with the USPTO as a Receiving Office**

**If a new international application is being filed and the international application includes the necessary components for an international filing date (see PCT Article 11 and MPEP 1810), a Notification of the International Application Number and of the International Filing Date (Form PCT/RO/105) will be issued in due course, subject to prescriptions concerning national security, and the date shown on this Acknowledgement Receipt will establish the international filing date of the application.**

Under the Paperwork Reduction Act of 1995, no persons are required to respond to a collection of information unless it contains a valid OMB control number.

<b>Application Data Sheet 37 CFR 1.76</b>		Attorney Docket Number	080900.1371
		Application Number	
Title of Invention	Two-Layer Sensor Stack		
The application data sheet is part of the provisional or nonprovisional application for which it is being submitted. The following form contains the bibliographic data arranged in a format specified by the United States Patent and Trademark Office as outlined in 37 CFR 1.76. This document may be completed electronically and submitted to the Office in electronic format using the Electronic Filing System (EFS) or the document may be printed and included in a paper filed application.			

**Secrecy Order 37 CFR 5.2**

<input type="checkbox"/>	Portions or all of the application associated with this Application Data Sheet may fall under a Secrecy Order pursuant to 37 CFR 5.2 (Paper filers only. Applications that fall under Secrecy Order may not be filed electronically.)
--------------------------	---

**Applicant Information:**

<b>Applicant 1</b>					
<b>Applicant Authority</b>		<input checked="" type="radio"/> Inventor		<input type="radio"/> Legal Representative under 35 U.S.C. 117	
				<input type="radio"/> Party of Interest under 35 U.S.C. 118	
<b>Prefix</b>	<b>Given Name</b>	<b>Middle Name</b>	<b>Family Name</b>	<b>Suffix</b>	
	David	Brent	Guard		
<b>Residence Information (Select One)</b> <input type="radio"/> US Residency <input checked="" type="radio"/> Non US Residency <input type="radio"/> Active US Military Service					
<b>City</b>	Hampshire	<b>Country Of Residence</b>	GB		
<b>Citizenship under 37 CFR 1.41(b)</b>		GB			
<b>Mailing Address of Applicant:</b>					
<b>Address 1</b>		1560 Parkway, Solent Business Park			
<b>Address 2</b>		Whiteley, Fareham			
<b>City</b>	Hampshire	<b>State/Province</b>			
<b>Postal Code</b>	P015 7AG	<b>Country</b>	GB		
<b>Applicant 2</b>					
<b>Applicant Authority</b>		<input checked="" type="radio"/> Inventor		<input type="radio"/> Legal Representative under 35 U.S.C. 117	
				<input type="radio"/> Party of Interest under 35 U.S.C. 118	
<b>Prefix</b>	<b>Given Name</b>	<b>Middle Name</b>	<b>Family Name</b>	<b>Suffix</b>	
	Esat		Yilmaz		
<b>Residence Information (Select One)</b> <input checked="" type="radio"/> US Residency <input type="radio"/> Non US Residency <input type="radio"/> Active US Military Service					
<b>City</b>	Santa Cruz	<b>State/Province</b>	CA	<b>Country of Residence</b>	US
<b>Citizenship under 37 CFR 1.41(b)</b>		GB			
<b>Mailing Address of Applicant:</b>					
<b>Address 1</b>		2325 Orchard Parkway			
<b>Address 2</b>					
<b>City</b>	San Jose	<b>State/Province</b>		CA	
<b>Postal Code</b>	95131	<b>Country</b>	US		
<b>Applicant 3</b>					
<b>Applicant Authority</b>		<input checked="" type="radio"/> Inventor		<input type="radio"/> Legal Representative under 35 U.S.C. 117	
				<input type="radio"/> Party of Interest under 35 U.S.C. 118	
<b>Prefix</b>	<b>Given Name</b>	<b>Middle Name</b>	<b>Family Name</b>	<b>Suffix</b>	
	Tsung-Ching		Wu		
<b>Residence Information (Select One)</b> <input checked="" type="radio"/> US Residency <input type="radio"/> Non US Residency <input type="radio"/> Active US Military Service					
<b>City</b>	Saratoga	<b>State/Province</b>	CA	<b>Country of Residence</b>	US PETITIONERS



Under the Paperwork Reduction Act of 1995, no persons are required to respond to a collection of information unless it contains a valid OMB control number.

<b>Application Data Sheet 37 CFR 1.76</b>		Attorney Docket Number	080900.1371
		Application Number	
Title of Invention	Two-Layer Sensor Stack		

Citizenship under 37 CFR 1.41(b)	US		
<b>Mailing Address of Applicant:</b>			
Address 1	2325 Orchard Parkway		
Address 2			
City	San Jose	State/Province	CA
Postal Code	95131	Country	US
All Inventors Must Be Listed - Additional Inventor Information blocks may be generated within this form by selecting the <b>Add</b> button.			<input type="button" value="Add"/>

**Correspondence Information:**

Enter either Customer Number or complete the Correspondence Information section below. For further information see 37 CFR 1.33(a).			
<input type="checkbox"/> An Address is being provided for the correspondence information of this application.			
Customer Number	12323		
Email Address	PTOmail1@bakerbotts.com	<input type="button" value="Add Email"/>	<input type="button" value="Remove Email"/>

**Application Information:**

Title of the Invention	Two-Layer Sensor Stack		
Attorney Docket Number	080900.1371	Small Entity Status Claimed	<input type="checkbox"/>
Application Type	Nonprovisional		
Subject Matter	Utility		
Suggested Class (if any)		Sub Class (if any)	
Suggested Technology Center (if any)			
Total Number of Drawing Sheets (if any)	9	Suggested Figure for Publication (if any)	1

**Publication Information:**

<input type="checkbox"/> Request Early Publication (Fee required at time of Request 37 CFR 1.219)
<input type="checkbox"/> <b>Request Not to Publish.</b> I hereby request that the attached application not be published under 35 U.S.C. 122(b) and certify that the invention disclosed in the attached application <b>has not and will not</b> be the subject of an application filed in another country, or under a multilateral international agreement, that requires publication at eighteen months after filing.

**Representative Information:**

Representative information should be provided for all practitioners having a power of attorney in the application. Providing this information in the Application Data Sheet does not constitute a power of attorney in the application (see 37 CFR 1.32). Enter either Customer Number or complete the Representative Name section below. If both sections are completed the Customer Number will be used for the Representative Information during processing.			
Please Select One:	<input checked="" type="radio"/> Customer Number	<input type="radio"/> US Patent Practitioner	<input type="radio"/> Limited Recognition (37 CFR 11.9)

PETITIONERS

Under the Paperwork Reduction Act of 1995, no persons are required to respond to a collection of information unless it contains a valid OMB control number.

<b>Application Data Sheet 37 CFR 1.76</b>		Attorney Docket Number	080900.1371
		Application Number	
Title of Invention	Two-Layer Sensor Stack		
Customer Number	12323		

**Domestic Benefit/National Stage Information:**

This section allows for the applicant to either claim benefit under 35 U.S.C. 119(e), 120, 121, or 365(c) or indicate National Stage entry from a PCT application. Providing this information in the application data sheet constitutes the specific reference required by 35 U.S.C. 119(e) or 120, and 37 CFR 1.78(a)(2) or CFR 1.78(a)(4), and need not otherwise be made part of the specification.

Prior Application Status	Pending	<input type="button" value="Remove"/>	
Application Number	Continuity Type	Prior Application Number	Filing Date (YYYY-MM-DD)
	Continuation of	13/089061	2011-04-18

Additional Domestic Benefit/National Stage Data may be generated within this form by selecting the **Add** button.

**Foreign Priority Information:**

This section allows for the applicant to claim benefit of foreign priority and to identify any prior foreign application for which priority is not claimed. Providing this information in the application data sheet constitutes the claim for priority as required by 35 U.S.C. 119(b) and 37 CFR 1.55(a).

<input type="button" value="Remove"/>			
Application Number	Country	Parent Filing Date (YYYY-MM-DD)	Priority Claimed
			<input type="radio"/> Yes <input checked="" type="radio"/> No

Additional Foreign Priority Data may be generated within this form by selecting the **Add** button.

**Assignee Information:**

Providing this information in the application data sheet does not substitute for compliance with any requirement of part 3 of Title 37 of the CFR to have an assignment recorded in the Office.

**Assignee 1**

If the Assignee is an Organization check here.

Prefix	Given Name	Middle Name	Family Name	Suffix

**Mailing Address Information:**

Address 1			
Address 2			
City		State/Province	
Country		Postal Code	
Phone Number		Fax Number	
Email Address			

Additional Assignee Data may be generated within this form by selecting the **Add** button.

**Signature:**

A signature of the applicant or representative is required in accordance with 37 CFR 1.33 and 10.18. Please see 37 CFR 1.4(d) for the form of the signature.

PETITIONERS  
Exhibit 1003, Page 286

Under the Paperwork Reduction Act of 1995, no persons are required to respond to a collection of information unless it contains a valid OMB control number.

<b>Application Data Sheet 37 CFR 1.76</b>	Attorney Docket Number	080900.1371
	Application Number	
Title of Invention	Two-Layer Sensor Stack	

<b>Signature</b>	/Travis Thomas/		Date (YYYY-MM-DD)	2011-12-06	
First Name	Travis	Last Name	Thomas	Registration Number	48667

This collection of information is required by 37 CFR 1.76. The information is required to obtain or retain a benefit by the public which is to file (and by the USPTO to process) an application. Confidentiality is governed by 35 U.S.C. 122 and 37 CFR 1.14. This collection is estimated to take 23 minutes to complete, including gathering, preparing, and submitting the completed application data sheet form to the USPTO. Time will vary depending upon the individual case. Any comments on the amount of time you require to complete this form and/or suggestions for reducing this burden, should be sent to the Chief Information Officer, U.S. Patent and Trademark Office, U.S. Department of Commerce, P.O. Box 1450, Alexandria, VA 22313-1450. DO NOT SEND FEES OR COMPLETED FORMS TO THIS ADDRESS. **SEND TO: Commissioner for Patents, P.O. Box 1450, Alexandria, VA 22313-1450.**

# Privacy Act Statement

The Privacy Act of 1974 (P.L. 93-579) requires that you be given certain information in connection with your submission of the attached form related to a patent application or patent. Accordingly, pursuant to the requirements of the Act, please be advised that: (1) the general authority for the collection of this information is 35 U.S.C. 2(b)(2); (2) furnishing of the information solicited is voluntary; and (3) the principal purpose for which the information is used by the U.S. Patent and Trademark Office is to process and/or examine your submission related to a patent application or patent. If you do not furnish the requested information, the U.S. Patent and Trademark Office may not be able to process and/or examine your submission, which may result in termination of proceedings or abandonment of the application or expiration of the patent.

The information provided by you in this form will be subject to the following routine uses:

1. The information on this form will be treated confidentially to the extent allowed under the Freedom of Information Act (5 U.S.C. 552) and the Privacy Act (5 U.S.C. 552a). Records from this system of records may be disclosed to the Department of Justice to determine whether the Freedom of Information Act requires disclosure of these records.
2. A record from this system of records may be disclosed, as a routine use, in the course of presenting evidence to a court, magistrate, or administrative tribunal, including disclosures to opposing counsel in the course of settlement negotiations.
3. A record in this system of records may be disclosed, as a routine use, to a Member of Congress submitting a request involving an individual, to whom the record pertains, when the individual has requested assistance from the Member with respect to the subject matter of the record.
4. A record in this system of records may be disclosed, as a routine use, to a contractor of the Agency having need for the information in order to perform a contract. Recipients of information shall be required to comply with the requirements of the Privacy Act of 1974, as amended, pursuant to 5 U.S.C. 552a(m).
5. A record related to an International Application filed under the Patent Cooperation Treaty in this system of records may be disclosed, as a routine use, to the International Bureau of the World Intellectual Property Organization, pursuant to the Patent Cooperation Treaty.
6. A record in this system of records may be disclosed, as a routine use, to another federal agency for purposes of National Security review (35 U.S.C. 181) and for review pursuant to the Atomic Energy Act (42 U.S.C. 218(c)).
7. A record from this system of records may be disclosed, as a routine use, to the Administrator, General Services, or his/her designee, during an inspection of records conducted by GSA as part of that agency's responsibility to recommend improvements in records management practices and programs, under authority of 44 U.S.C. 2904 and 2906. Such disclosure shall be made in accordance with the GSA regulations governing inspection of records for this purpose, and any other relevant (i.e., GSA or Commerce) directive. Such disclosure shall not be used to make determinations about individuals.
8. A record from this system of records may be disclosed, as a routine use, to the public after either publication of the application pursuant to 35 U.S.C. 122(b) or issuance of a patent pursuant to 35 U.S.C. 151. Further, a record may be disclosed, subject to the limitations of 37 CFR 1.14, as a routine use, to the public if the record was filed in an application which became abandoned or in which the proceedings were terminated and which application is referenced by either a published application, an application open to public inspections or an issued patent.
9. A record from this system of records may be disclosed, as a routine use, to a Federal, State, or local law enforcement agency, if the USPTO becomes aware of a violation or potential violation of law or regulation.

TWO-LAYER SENSOR STACK

RELATED APPLICATION

[1] This application is a continuation under 35 U.S.C. § 120 of U.S. Patent Application No. 13/089,061, filed 18 April 2011.

TECHNICAL FIELD

[2] This disclosure generally relates to touch sensors.

**Background**

[0001] A position sensor can detect the presence and location of a touch by a finger or by an object, such as a stylus, within an area of an external interface of the position sensor. In a touch sensitive display application, the position sensor enables, in some circumstances, direct interaction with information displayed on the screen, rather than indirectly via a mouse or touchpad. Position sensors can be attached to or provided as part of devices with a display. Examples of devices with displays include, but are not limited to, computers, personal digital assistants, satellite navigation devices, mobile telephones, portable media players, portable game consoles, public information kiosks, and point of sale systems. Position sensors have also been used as control panels on various appliances.

[0002] There are a number of different types of position sensors. Examples include, but are not limited to resistive touch screens, surface acoustic wave touch screens, capacitive touch screens, and the like. A capacitive touch screen, for example, may include an insulator coated with a transparent conductor in a particular pattern. When an object, such as a finger or a stylus, touches the surface of the screen there may be a change in capacitance. This change in capacitance may be sent to a controller for processing to determine where the touch occurred on the touch screen.

[0003] In a mutual capacitance configuration, for example, an array of conductive drive electrodes or lines and conductive sense electrodes or lines can be used to form a touch screen having capacitive nodes. A node may be formed where a drive electrode and a sense electrode overlap. The electrodes may be separated by an insulator to avoid electrical contact. The sense electrodes may be capacitively coupled with the drive electrodes at the nodes. A pulsed or alternating voltage applied on a drive electrode may therefore induce a charge on the sense electrodes that overlap with the drive electrode. The amount of induced charge may be susceptible to external influence, such as from the proximity of a nearby finger. When an object touches the surface of the screen, the capacitance change at each node on the grid can be measured to determine the position of the touch.

[0004] While clear conductors such as ITO may be used for electrodes, opaque metal electrodes also may be used. The opaque metal electrodes may be made of a conductive mesh

of thin conductors, which may be of copper, silver or other conductive materials. The thin conductors may be made very thin as to be substantially invisible to the naked eye.

### **Summary**

[0005] An electrode pattern for a position sensing panel may have an array of mesh cells formed by sinusoidally shaped conductive lines extending between vertices of the mesh cells.

### **Brief Description of the Figures**

[0006] The figures depict one or more implementations in accordance with the present disclosure, by way of example, not by way of limitation. In the figures, like reference numerals refer to the same or similar elements.

[0007] FIG. 1 is a cross-sectional view of an exemplary touch sensitive panel and a display;

[0008] FIGS. 2a-b illustrate schematically exemplary electrode patterns useable in the touch sensitive panel of FIG. 1;

[0009] FIGS. 3A-3C illustrate schematically an arrangement of two of the electrode patterns of FIG. 2a overlying one another;

[0010] FIG. 4 illustrates schematically another electrode pattern useable in the touch sensitive panel of FIG. 1;

[0011] FIG. 5 illustrates schematically another electrode pattern useable in the touch sensitive panel of FIG. 1;

[0012] FIG. 6 illustrates schematically another electrode pattern useable in the touch sensitive panel of FIG. 1;

[0013] FIG. 7 illustrates schematically another electrode pattern useable in the touch sensitive panel of FIG. 1;

[0014] FIG. 8 illustrates schematically another electrode pattern useable in the touch sensitive panel of FIG. 1;

[0015] FIG. 9 illustrates schematically another electrode pattern useable in the touch sensitive panel of FIG. 1;

[0016] FIG. 10 illustrates schematically another electrode pattern useable in the touch sensitive panel of FIG. 1;

[0017] FIG. 11 illustrates schematically another electrode pattern useable in the touch sensitive panel of FIG. 1;

[0018] FIG. 12 illustrates schematically another electrode pattern useable in the touch sensitive panel of FIG. 1;

[0019] FIG. 13 illustrates schematically another electrode pattern useable in the touch sensitive panel of FIG. 1; and

[0020] FIG. 14 illustrates schematically another electrode pattern useable in the touch sensitive panel of FIG. 1.

### **Detailed Description**

[0021] In the following detailed description, numerous specific details are set forth by way of examples. In order to avoid unnecessarily obscuring examples of the present disclosure, those methods, procedures, components, and/or circuitry that are well-known to one of ordinary skill in the art have been described at a relatively high level.

[0022] Reference is now made in detail to the examples illustrated in the accompanying figures and discussed below.

[0023] A display may be overlaid with a touch position-sensing panel to implement a touch sensitive display device. Exemplary displays include liquid crystal displays, active matrix liquid crystal displays, electroluminescent displays, electrophoretic displays, plasma displays, cathode-ray displays, OLED displays, or the like. It will be appreciated that light emitted from the display may be able to pass through the touch position-sensing panel with minimal absorption or obstruction.

[0024] FIG. 1 illustrates an exemplary touch position-sensing panel 1 which overlies a display 2. In the illustrated example, the panel 1 includes an insulating substrate 3 having two opposing faces. Although touch sensors may implement other types of touch sensing, for discussion purposes, the drawing shows an example of a structure that may be used to implement a mutual capacitance type touch sensitive panel.

[0025] The panel 1 includes a number of electrodes 4 (X) and a number of electrodes 5 (Y) provided on opposite faces 3a and 3b of the substrate 3. The electrodes 4 (X), which may be on face 3b, may be arranged in one direction and the electrodes 5 (Y), which may be on face 3a, may be arranged in a direction different than the direction of electrodes 4 (X). Other conductive tracks may also be provided on the opposing faces 3a and 3b of the substrate 3. Such other conductive tracks may provide drive and sense connections to the



electrodes 4 (X) and 5 (Y). The substrate 3 may be provided adjacent to the display 2 such that electrodes 4 (X) are arranged between the display 2 and the substrate 3. An adhesive layer 6 of an optically clear adhesive may be between the electrodes 4 (X) and a transparent covering sheet 7. Another adhesive layer 8 of an optically clear adhesive may be between the electrodes 5 (Y) and a transparent covering sheet 9. A gap may be formed between the display 2 and the transparent covering sheet 7.

[0026] The transparent covering sheet 7 and the adhesive layer 6 of optically clear adhesive may encapsulate the electrodes 4 (X), and any other conductive tracks formed on face 3b of the substrate 3. The transparent covering sheet 9 and the adhesive layer 8 of optically clear adhesive may encapsulate the electrodes 5 (Y), and any other conductive tracks formed on face 3a of the substrate 3. The encapsulation of the electrodes 4 (X) and 5 (Y), and any other conductive tracks, may provide protection from physical and environmental damage. In some examples, portions of the conductive tracks may be exposed to provide connection points for connection to external drive circuitry.

[0027] In the mutual capacitance example, electrodes 4 (X) may be drive electrodes provided on face 3b of the substrate 3, and electrodes 5 (Y) may be sense electrodes provided on the opposing face 3a of the substrate 3. Capacitive sensing channels may be formed by capacitive coupling nodes in the localized regions at an around where electrodes 4 (X) and 5 (Y) cross over each other and are separated by the substrate 3.

[0028] One or both of the sets of electrodes 4 (X) and 5 (Y) may be formed from a conductive material, such as a metal. Suitable metals include copper, silver, gold, aluminum, tin and other metals used in conductive wiring. In some examples, the sense electrodes may be patterned in narrow lines to allow most of the light emitted from the display and incident on the sense electrode layer to pass through the electrode layer between the narrow metal lines. The narrow lines may be no more than 20 microns wide. An exemplary range may be 1-5 microns. Narrower lines have reduced visibility to the naked eye. By forming electrodes 4 (X) or 5 (Y) from narrow conductive lines, the position-sensing panel may be formed such that no more than about 10% of the active area is covered by the metal lines of the electrodes. Less coverage of the active area allows for greater transparency of the position-sensing panel reduces visibility of the electrodes to the human eye and reduces perceptible darkening or other loss of display quality. An exemplary coverage may be less than 5%.

[0029] In some examples, the electrodes 4 (X) may be formed from a clear conductive material and the electrodes 5 (Y) may be formed from narrow conductive lines. In other examples, the electrodes 4 (X) may be formed from narrow conductive lines and the electrodes 5 (Y) may be formed from a clear conductive material.

[0030] In an example where other conductive tracks in addition to the electrodes 4 (X) and 5 (Y) are provided on the substrate 3, the other conductive tracks may also be formed from a clear conductive material or narrow conductive lines, in a manner similar to the electrode layers 4 (X) and 5 (Y). In an example where the other conductive tracks, or parts of the other conductive tracks, lie outside a visible region of the display 2, the light-transmissibility of the other conductive tracks is of no concern.

[0031] FIG. 2a illustrates an exemplary electrode pattern 10 which may be used in the touch position-sensing panel 1. The exemplary electrode pattern may be used to form any one electrode of either set of the electrodes 4 (X) and 5 (Y). The electrode pattern 10 may be formed by a number of straight conductive lines 11 arranged to interconnect at connection points to define a conductive grid or mesh pattern made up of an array of square shaped mesh cells 13 arranged in a layer. The connection points of the conductive lines 11 are the vertices 12 of the square shaped mesh cells 13. The conductive lines may be formed of copper with a width in the range approximately  $1\mu\text{m}$  to approximately  $10\mu\text{m}$  and size of the mesh pattern, that is, the spacing of the vertices, may be in the range approximately  $500\mu\text{m}$  to approximately  $10\text{mm}$ . In one example, the electrode pattern 10 may be arranged so that no more than approximately 5% of the surface of the touch position-sensing panel is covered by the conductive lines 11. Thus, the contribution of the conductive lines to the attenuation of light through a sensor should not be more than approximately 5%. Accordingly, although the conductive lines 11 may be opaque, in this example, the combined optical transmissivity of the electrode pattern 10 and all other electrode patterns on the panel may be 90% or more, allowing any display below the touch position-sensing panel 1 to be visible with little perceptible darkening or other loss of display quality.

[0032] In other examples, the electrode pattern may be formed by a number of square shaped mesh cells 13a that do not have four metal lines meet at vertices. Instead of the connection points of the conductive lines being the vertices of the square shaped mesh cells as shown in FIG. 2a, in FIG. 2b, each of the square shaped mesh cells 13a may be separated from adjacent cells by a connecting segment 14. This arrangement may result in reduced line

density on the vertices 12 by reducing the number of converging metal lines 11a from 4 to 3. While the connecting segments 14 in FIG. 2b are straight, in other examples, the connecting segments may be sinusoidal or non-linear, and may be at any angle relative to the vertices 12a.

[0033] FIGs. 3A-3C illustrate an example of electrode patterns 10a and 10b formed so that the two electrode patterns 10a and 10b overlay one another. The two electrode patterns 10a and 10b may be offset so that the vertices 12a, 12b of each one of the electrode patterns 10a and 10b are located at, or near to, the centers of the square shapes 13a, 13b of the other one of the electrode patterns 10a and 10b. As a result of this offsetting of the two electrode patterns 10a and 10b, the conductive lines 11a and 11b of the two electrode patterns 10a and 10b may be distributed evenly across the touch position-sensing panel 1.

[0034] In other examples, the mesh pattern may be made up of an array of other regular trapezoid shaped mesh cells. In one example, the mesh pattern may be made up of an array of two different diamond shaped mesh cells which tessellate to form the mesh pattern.

[0035] An example of a portion of an electrode pattern 14 is shown in FIG 4. In this illustrated example, the electrode pattern 14 may be formed of conductive lines 15 arranged to interconnect at connection points to define a conductive grid or mesh pattern made up of an array of substantially square shaped mesh cells 17 arranged in a layer. The connection points of the conductive lines 15 form vertices 16 of the square shaped mesh cells 17. In FIG. 4, a single substantially square shaped mesh cell 17 is shown together with parts of the conductive lines 15 defining adjacent substantially square shaped mesh cells 17.

[0036] In the illustrated example of FIG. 4, the conductive lines 15 extending between the vertices 16 are not straight. As can be seen in the illustrated example, each of the conductive lines 15 may have a sinusoidal shape. Each conductive metal line 15 may be arranged as a sinusoidal line centered on a path that would be taken by a straight line between the vertices 16 linked by the conductive metal line 15. Thus, comparing the examples illustrated in FIG. 2 and FIG. 4, each sinusoidal conductive metal line 15 illustrated in FIG. 4 may be centered about, and may extend to either side of, one of the straight conductive lines 11 illustrated in FIG. 2, shown as dotted lines in FIG. 4. The mesh cells 17 shown in FIG. 4 may be described as substantially square because, although the vertices 16 are arranged in a square, the sinusoidal shape of the conductive lines 15 may result in mesh cells 17 that are substantially, but not precisely, square shaped.

[0037] The sinusoidal shape of the conductive lines 15 as shown in FIG. 4 may reduce diffraction effects which may be encountered if straight conductive lines are used. Such diffraction effects may result in the appearance of “starburst” patterns when a touch position-sensing panel is subject to bright ambient light. Such diffraction effects may result in color shifting, changing the apparent colors of liquid crystal display (LCD) elements of a display visible through a touch position-sensing panel, and may obscure the image being displayed.

[0038] The sinusoidal shape of the conductive lines 15 in the illustrated example may reduce the visibility of reflections from the conductive lines when a touch position sensing panel is illuminated by light from a point illumination source, such as the sun on a clear day. The sinusoidal shape of the conductive lines 15 may tend to distribute or disperse the apparent position on the touch position sensing panel of such reflections, and so may minimize the perceived visibility of repetitive reflection patterns. Such repetitive reflection patterns are readily perceived by the human eye.

[0039] In FIG. 4, each sinusoidal conductive metal line makes two complete sinusoidal cycles between two vertices 16. In other examples, each sinusoidal conductive line may make a different number of cycles between two vertices 16.

[0040] In some examples, the sinusoidal conductive lines may be formed as continuous curves. In other examples, the sinusoidal conductive lines may be formed by a number of short straight line sections arranged in a triangular waveform shape to approximate a sinusoidal shape. In other examples, the conductive lines may be shaped as other types of curves. In some examples, the conductive lines may be shaped as curves extending from a path that would be taken by a straight line between the vertices linked by the conductive metal line.

[0041] Another example of an electrode pattern 18 is shown in FIG. 5. In this example, the electrode pattern 18 may be formed by conductive lines 20 arranged to interconnect at connection points to define a conductive grid or mesh pattern made up of an array of substantially diamond shaped mesh cells 19 arranged in a layer. The connection points of the conductive lines 20 form vertices 21 of the diamond shaped mesh cells 19. In FIG. 5 a single substantially diamond shaped mesh cell 19 is shown, together with parts of the conductive lines 20 defining adjacent ones of the substantially diamond shaped mesh cells 19. The mesh cells 19 in FIG. 5 may be substantially diamond shaped. For example, although the vertices 21 are arranged in a diamond, the sinusoidal shape of the conductive lines 20 may

result in mesh cells 19 that are substantially diamond shaped, varying from a straight line, as shown by the dotted lines.

[0042] In other examples, the mesh pattern may be made up of an array of other substantially regular trapezoid shaped mesh cells. In one example, the mesh pattern may be made up of a tessellated array of two different substantially diamond shaped mesh cells.

[0043] In other examples, the amplitude of the sinusoidal shape of the sinusoidal conductive lines may be varied. For example, the distance the peaks of the sinusoidal shaped conductive lines extend away from a path that would be taken by a straight line between the vertices linked by the sinusoidal conductive lines may be varied. The amplitude of the sinusoidal shape of the sinusoidal conductive lines may be varied between the different sinusoidal conductive lines, and may also be varied at different points along one, some or all of the sinusoidal conductive lines.

[0044] A portion of another electrode pattern 22 is shown in FIG. 6. In this example, the electrode pattern 22 may be formed by conductive lines 23 arranged to interconnect at connection points to define a conductive grid or mesh pattern made up of an array of substantially square shaped mesh cells 24 arranged in a layer. The connection points of the conductive lines 23 form vertices 25 of the corners of the mesh cell 24. In FIG. 6, a single mesh cell 24 is shown, together with parts of the conductive lines 23 defining adjacent mesh cells 24. Although the vertices 25 may be arranged at the corners of the mesh cell to form a square shape, the sinusoidal shape of the conductive lines 23 may vary from a straight line and results in mesh cells 24 that may be substantially square.

[0045] For example, as shown in FIG. 6, the conductive lines 23 extending between the vertices 25 may have a sinusoidal shape similar to the example illustrated in FIG. 4. Each conductive metal line 23 may be arranged as a sinusoidal line centered on a path that would be taken by a straight line between the vertices 25 linked by the sinusoidal conductive metal line 23.

[0046] In FIG. 6, the sinusoidal conductive lines 23 may have varying amplitudes. For example, sinusoidal conductive metal line 23a and sinusoidal conductive metal line 23b may have different amplitudes. The conductive metal line 23a may have a smaller amplitude than the sinusoidal conductive metal line 23b. Further, a sinusoidal conductive metal line 23c may have sections 23d and 23e with different amplitudes. The section 23d of the sinusoidal

conductive metal line 23c may have a larger amplitude than the sections 23e of the sinusoidal conductive metal line 23c.

[0047] As shown, the sinusoidal conductive lines in FIG. 6 may have two different amplitudes. In other examples, the sinusoidal conductive lines may have other number of different amplitudes.

[0048] In an example of an electrode using the cell of FIG. 6, the mesh pattern may be made up of an array of substantially square shaped mesh cells, such as an array of other substantially regular trapezoid shaped mesh cells. In another example, the mesh pattern may be made up of an array of substantially diamond shaped mesh cells. In one example, the mesh pattern may be made up of a tessellated array of two different substantially diamond shaped mesh cells.

[0049] In other examples, the wavelength of the sinusoidal shape of the sinusoidal conductive lines may be varied. That is, the distance between the crossing points where the sinusoidal shaped conductive lines cross a path that would be taken by a straight line between the vertices linked by the sinusoidal conductive lines may be varied. The wavelength of the sinusoidal shape of the sinusoidal conductive lines may be varied between the different sinusoidal conductive lines and/or may be varied at different points along one, some or all of the sinusoidal conductive lines.

[0050] A portion of another electrode pattern 26 is shown in FIG. 7. In this example, the electrode pattern 26 may be formed by conductive lines 27 arranged to interconnect at connection points to define a conductive grid or mesh pattern made up of an array of substantially square shaped mesh cells 28 arranged in a layer, similar to the electrode pattern 14 illustrated in FIG. 4. The connection points of the conductive lines 27 form vertices 29 of the square shaped mesh cells 28. In FIG. 7, a single substantially square shaped mesh cell 28 is shown, together with parts of the conductive lines 27 defining adjacent substantially square shaped mesh cells 28.

[0051] As shown in FIG. 7, the conductive lines 27 extending between the vertices 29 may have a sinusoidal shape. Each conductive metal line 27 may be arranged as a sinusoidal line centered on a path that would be taken by a straight line between the vertices 29 linked by the sinusoidal conductive metal line 27.

[0052] In this example, the sinusoidal conductive lines 27 may have varying wavelengths. As is illustrated in FIG. 7, a sinusoidal conductive metal line 27a, a sinusoidal

conductive metal line 27b, and a sinusoidal conductive metal line 27c may each have different wavelengths. The conductive metal line 27a may have a smaller wavelength than the sinusoidal conductive metal line 27b. In turn, the sinusoidal conductive metal line 27b may have a smaller wavelength than the sinusoidal conductive metal line 27c. Further, a sinusoidal conductive metal line 27d may have sections 27e and 27f with different wavelengths. The section 27e of the sinusoidal conductive metal line 27d may have a shorter wavelength than the sections 27f of the sinusoidal conductive metal line 27d.

[0053] As shown, the sinusoidal conductive lines of FIG. 7 may have three different wavelengths. In other examples, the sinusoidal conductive lines may have any number of different wavelengths.

[0054] In other examples, both the amplitude and the wavelength of the sinusoidal shape of the sinusoidal conductive lines may be varied. The amplitude and/or the wavelength of the sinusoidal shape of the sinusoidal conductive lines may be varied between the different sinusoidal conductive lines, and may also be varied at different points along one, some or all of the sinusoidal conductive lines.

[0055] A portion of another electrode pattern 30 is shown in FIG. 8. In this example, the electrode pattern 30 may be formed by conductive lines 31 arranged to interconnect at connection points to define a conductive grid or mesh pattern made up of an array of substantially square shaped mesh cells 32 arranged in a layer. The connection points of the conductive lines 31 form vertices 33 of the square shaped mesh cells 32. In FIG. 8, a single substantially square shaped mesh cell 32 is shown, together with parts of the conductive lines 31 defining adjacent substantially square shaped mesh cells 32. The mesh cells 32 in the example shown in FIG. 8 may be substantially square.

[0056] In the example of FIG. 8, the conductive lines 31 extending between the vertices 33 have a varying sinusoidal shape. Each conductive metal line 31 may be arranged as an irregular sinusoidal line centered on a path that would be taken by a straight line between the vertices 33 linked by the sinusoidal conductive metal line 31.

[0057] In this example, the conductive lines 31 have varying amplitudes and varying wavelengths of the sinusoids. As is illustrated in FIG. 8, a sinusoidal conductive metal line 31a and a sinusoidal conductive metal line 31b have different amplitudes and wavelengths. The sinusoidal conductive metal line 31a may have a longer wavelength and a smaller amplitude than the sinusoidal conductive metal line 31b. A sinusoidal conductive metal line

31c may have a shorter wavelength than sinusoidal conductive metal line 31b. The sinusoidal conductive metal line 31c may have sections 31e and 31f with different amplitudes. The sections 31e of the sinusoidal conductive metal line 31c have a smaller amplitude than the sections 31f of the sinusoidal conductive metal line 31c. A sinusoidal conductive metal line 31d may have sections with different wavelengths and different amplitudes. The sinusoidal conductive metal line 31d may have sections 31g and 31h with different wavelengths. Section 31g of the sinusoidal conductive metal line 31d may have a shorter wavelength than section 31h of sinusoidal conductive metal line 31d. Further, section 31g of sinusoidal conductive metal line 31d may have sections 31j and 31k with different amplitudes. Section 31j may have a smaller amplitude than section 31k.

[0058] As shown, the sinusoidal conductive lines in FIG. 8 may have three different wavelengths and two different amplitudes. In other examples, the sinusoidal conductive lines may have other numbers of different wavelengths and other numbers of different amplitudes.

[0059] In other examples, a phase change between the sinusoidal shapes of the sinusoidal conductive lines where the sinusoidal conductive lines interconnect at connection points may be varied.

[0060] A portion of another electrode pattern 34 is shown in FIG. 9. For convenience, the drawing shows one vertex and two sinusoids, one on either side of the vertex, for the lines connect at the vertex. In this example, the electrode pattern 34 may be formed by sinusoidal conductive lines 35a to 35d arranged to interconnect at a connection point 36 to define a conductive grid or mesh pattern made up of an array of mesh cells. The connection point 36 of the sinusoidal conductive lines 35a to 35d form a vertex of four of the mesh cells. In FIG. 9, a single connection point 36 is shown, together with parts of the sinusoidal conductive lines 35a to 35d which interconnect at the connection point 36.

[0061] In the illustrated example, four sinusoidal conductive lines 35a to 35d and the connection point 36 of those four lines 35a to 35d may be part of an electrode pattern 34 defining an array of substantially square shaped mesh cells arranged in a layer. As discussed regarding the previous examples, the sinusoidal conductive lines may be sinusoidal shapes extending to either side of the path of a straight line extending between adjacent connection points or vertices of the electrode pattern 34. In the exemplary orientation, because the electrode pattern 34 may define an array of substantially square shaped mesh cells, a sinusoidal conductive metal line 35a and a sinusoidal conductive metal line 35c may extend to



either side of the connection point 36 in one direction and may be aligned with one another. Similarly, a sinusoidal conductive metal line 35b and a sinusoidal conductive metal line 35d may extend to either side of the connection point 36 in another direction and may be aligned with one another. The sinusoidal metal lines 35a and 35c extend perpendicularly to the sinusoidal metal lines 35b and 35d.

[0062] In the example, the sinusoidal waveform of the conductive metal line 35a and the sinusoidal conductive metal line 35c may be in phase where the two conductive lines 35a and 35c meet at the connection point 36. Similarly, the sinusoidal waveform of the conductive metal line 35b and the sinusoidal waveform of the conductive metal line 35d may be in phase where the two conductive lines 35b and 35d meet at the connection point 36.

[0063] An example of a portion of another electrode pattern 37 is shown in FIG. 10. In this illustrated example, the electrode pattern 37 may be formed by a sinusoidal waveform of the conductive lines 39a to 39d arranged to interconnect at a connection point 38 to define a conductive grid or mesh pattern made up of an array of substantially square mesh cells. The connection point 38 of the sinusoidal waveform of the conductive lines 39a to 39d forms a vertex of four of the substantially square shaped mesh cells. In FIG. 10, a single connection point 38 is shown, together with parts of the conductive lines 39a to 39d which interconnect at the connection point 38.

[0064] In FIG. 10, four sinusoidal waveforms of the conductive lines 39a to 39d may be interconnected at the connection point 38. In the illustrated example, a sinusoidal waveform of the conductive metal line 39a and a sinusoidal waveform of the conductive metal line 39c may be in phase where the two conductive lines 39a and 39c meet at the connection point 38. In contrast, a sinusoidal waveform of the conductive metal line 39b and a sinusoidal waveform of the conductive metal line 39d may be in anti-phase, or 180° out of phase, where the two conductive lines 39b and 39d meet at the connection point 38.

[0065] In FIG. 9, the sinusoidal conductive lines may be arranged to be in phase where the sinusoidal conductive lines meet at connection points in the mesh pattern. In FIG. 10, the sinusoidal conductive lines 39a to 39d may be arranged to be in anti-phase where the sinusoidal conductive lines meet at some of the connection points 38 in the mesh pattern. In other examples, the sinusoidal conductive lines 39a to 39d may be arranged to be in anti-phase where the sinusoidal conductive lines meet at all of the connection points in the mesh pattern.

[0066] In other examples, the width of the conductive lines may be varied along their length.

[0067] A portion of another electrode pattern 40 is shown in FIG. 11. In this example, the electrode pattern 40 may include a sinusoidal conductive metal line 41. The sinusoidal conductive metal line 41 may have narrow sections 41a and broader sections 41b. The sinusoidal conductive metal line 41 may have a tapering width between the narrow sections 41a and broader sections 41b. In other examples, the width can vary non-linearly along the length of the sinusoidal conductive metal line 41.

[0068] A portion of another electrode pattern 42 is shown in FIG. 12. In this illustrated example, the electrode pattern 42 may be formed by sinusoidal conductive lines 43 arranged to interconnect at a connection point 44 to define a conductive grid or mesh pattern made up of an array of mesh cells. The connection point 44 of the sinusoidal conductive lines 43 forms a vertex of four of the shapes. In FIG. 12, a single connection point 44 is shown, together with parts of the sinusoidal conductive lines 43 which interconnect at the connection point 44.

[0069] In FIG. 12, each of the four sinusoidal conductive lines 43 may be relatively narrow at the connection point 44, and relatively broad away from the connection point 44. Each of the sinusoidal conductive lines 43 may have a tapered section which widens in a direction extending away from the connection point 44.

[0070] The examples shown in FIG. 11 and FIG. 12 may be combined. For example, the sinusoidal conductive lines may vary in width along their length and may be relatively narrow where the sinusoidal conductive lines interconnect at a connection point.

[0071] In the examples of FIG. 11 and FIG. 12, the conductive lines may be sinusoidal conductive lines. In other examples, the conductive lines could have other geometries. In some examples, the conductive lines which vary in width along their length and/or the conductive lines which may be narrowed where the conductive lines interconnect could be straight conductive lines.

[0072] FIG. 13 illustrates a portion of an exemplary electrode pattern 50 which may be used in the touch position-sensing panel 1. The exemplary electrode pattern may be used to form either electrodes 4 (X) and 5 (Y). In the illustrated example, the electrode pattern 50 may be formed by a number of conductive lines 51 arranged to interconnect at connection points to define a conductive grid or mesh pattern made up of an array of mesh cells 52. The

connection points of the conductive lines 51 may be the vertices 53 of the mesh cells 52. In the illustrated example, the pattern of the conductive lines 51 and mesh cells 52 may be determined by first arranging all of the vertices 53 of the mesh cells 52 in a regular square array. When the vertices 53 are in this square array, the mesh cells 52 may be square and the electrode pattern 50 may be similar to the illustrated example of FIG. 2.

[0073] The positions of some of the vertices 53 may vary. In the example, a vertex 53a may be a short distance to the left from the location 53b which would represent a regular square array. As is shown in FIG. 13, this position of the vertex 53a may result in distorted, non-square shapes of mesh cells 52a to 52d for which vertex 53a is a vertex. In one example, a vertex 53c may be a short distance downward and to the left from the location which the vertex 53c would have occupied in the regular square array. As is shown in FIG. 13, this displacement of the vertex 53c may further distort the shape of mesh cell 52d for which vertices 53a and 53c are both displaced away from positions corresponding to a square shape. The displacement of vertex 53c also may distort the shape of the mesh cells 52e to 52g for which the vertex 53c is displaced from a position corresponding to square shapes for the cells 52e, 52g.

[0074] In another example, the displaced vertex 53a and vertex 53c may be displaced by a random distance in a random direction, with the distance constrained to be no more than a predetermined range of distances. Thus, the vertex 53a may be constrained to be displaced to a position somewhere inside a circle 54 centered on the location 53b which the vertex 53a would have occupied in the regular square array and having a radius substantially equal to the predetermined maximum distance.

[0075] In some examples, the maximum displacement distance can be selected as a proportion of the distance between the vertices 53 in the regular square array. For example, the maximum displacement distance may be less than 0.5 times the distance between the vertices 53 in the regular square array. In one example, the displacement distance may be 0.1 times the distance between the vertices 53.

[0076] FIG. 13 shows vertices 53a and 53c displaced from positions that would otherwise produce the regular square array. In other examples, some or all of the vertices in an electrode pattern may be displaced.

[0077] Both the distance and direction of displacement of a vertex may be randomly selected. In some examples, the direction of displacement may be randomly selected while

the distance of displacement may be a fixed distance. In one example, this fixed distance of displacement may be approximately 0.1 times the spacing of the vertices.

[0078] In some examples, the distance of displacement may be varied in relation to the direction of displacement. In other examples, the amount of the variation may be varied based on the geometry of the array of vertices.

[0079] In some examples, the direction of displacement may be constrained so that the vertices can be displaced from positions corresponding to regular square shapes.

[0080] Although the lines appear as straight lines in the illustration, between vertices, the lines may have any of the sinusoidal shapes as discussed above relative to FIGs. 4-12.

[0081] Displacing the vertices of the electrode pattern away from positions in a regular geometric array may reduce the visibility of moiré effects. Such moiré effects may arise from interactions between the repeat length or cell size of an electrode pattern having vertices in a regular array and an element size of elements in a display visible through the touch position sensing panel. Such moiré effects may arise from interactions between the repeat length or cell size of an electrode pattern and a cell size of an LCD display visible through the touch position sensing panel. Moiré effects may produce a repeated pattern across the touch position sensing panel. Such repetitive interference patterns are readily perceived by the human eye.

[0082] As the deviation from regularity of a pattern of electrodes increases, the scattering of light increases. For example, Table 1 shows data from a Fast Fourier Transform (FFT) analysis of a mesh having a certain geometry. The FFT determines the number of angles formed by the reflection of light on a cell. As can be seen in the Table, as the randomness of the shape increases, a corresponding increase in angles occurs.

[0083] Table 1: FFT analysis of geometric shapes

Shape	Number of angles
One pixel	2
Equilateral Diamond	4
2 Diamonds of unequal height	8
4 diamonds with randomized vertices	32
one diamond with curved lines	>32
four diamonds with randomized	>>32

curves	
--------	--

[0084] However, the randomization of the lines should be balanced by the increase of the amount of wiring in the electrode due. The increased amount of wiring may cause for less transmittance of light through the panel.

[0085] FIG. 14 illustrates a portion of an exemplary electrode pattern 55 which may be used in the touch position-sensing panel 1. The exemplary electrode pattern may be used to form either electrodes 4 (X) and 5 (Y). In the illustrated example, the electrode pattern 55 may be formed by a number of conductive lines 56 arranged to interconnect at connection points to define a conductive grid or mesh pattern made up of an array of mesh cells 57. The connection points of the conductive lines 56 may be the vertices 58a to 58d of the mesh cells 57. In the example, the pattern of the conductive lines 56 and mesh cells 57 may be determined by selecting locations of a first group of vertices 58a. As is shown, the first group of vertices 58a may be uniformly spaced in a straight line. A second group of vertices 58b may then be selected at locations derived from the locations of the first group of vertices in a random manner.

[0086] As is shown in FIG. 14, this random selection may be carried out by randomly selecting a distance between each one of the vertices 58a and vertices 58b. Each of vertices 58b may be connected to one of vertices 58a by a conductive metal line 56. Thus, the distances between each one of the vertices 58a and each of the vertices 58b may be random.

[0087] The locations of vertices 58c may then be selected by repeating the random selection process based on the locations of vertices 58b. In some examples, the random selection process may be carried out by randomly selecting a distance between each one of the vertices 58b and each of the vertices 58c. Each vertex 58c may be connected to one of the vertices 58b by a conductive metal line 56. Thus, the distances between each one of the vertices 58b and vertices 58c may be random.

[0088] This selection process may then be repeated in an iterative manner until all of the selected area of the exemplary electrode pattern 55 has been populated with vertices 58a to 58d interconnected by conductive lines 56.

[0089] As a result of this iterative process of selecting locations of the vertices 58a to 58d the mesh cells 57 making up the electrode pattern 55 have random shapes and sizes. In

some examples, while the shapes comprising the mesh cells 57 may be random, the variations in the areas of the mesh cells 57 are minimized. For example, the variations in the areas of the mesh cells 57 from a mean mesh cell area of electrode pattern 55 are within 50%.

[0090] The randomly selected distances between vertices may be selected from a range having predetermined upper and lower limits. The predetermined upper and lower limits may be set at least in part based on the distances between the already located vertices.

[0091] In the illustrated example, the locations of the vertices and the conductive lines may be selected before the conductive lines are formed on the substrate.

[0092] In some examples, the conductive lines may be formed of copper with a width in the range approximately  $1\mu\text{m}$  to approximately  $10\mu\text{m}$ . In one example, the electrode pattern 10 is arranged so that no more than approximately 5% of the surface of the touch position-sensing panel may be covered by the conductive lines 56.

[0093] In FIG. 14, the vertices 58a to 58c may be arranged in a mesh pattern such that each vertex may be connected to four other vertices by four conductive lines 56. The vertices 58a to 58c may be initially arranged in an array of other regular trapezoid shapes. In one example, the vertices 58a to 58c may be arranged to define a mesh pattern such that each vertex is connected to another number of other vertices.

[0094] In other examples, different methods of randomly selecting the locations of the vertices may be used.

[0095] In some examples, the vertex locations determined by the iterative random selection of vertex locations may be checked to prevent conflicting vertex locations to occur. In some examples, when vertex locations conflict, the random selection process may be repeated until the vertex locations do not conflict. Examples of conflicting vertex locations include two or more vertices having one location, or vertex locations in which the conductive lines linking the vertices cross one another.

[0096] In some examples, the electrode pattern 55 may be iteratively defined by starting from one edge of a display or an electrode area and iteratively defining the positions of vertices until another edge of the display or electrode area is reached.

[0097] In FIG. 14, the conductive lines defining the electrode pattern may be shown as straight lines for simplicity and to allow easy understanding of the illustrated examples. In other examples, the conductive lines may be shaped according to any of the illustrated examples of FIGs. 4 to 12, either singly or in combination.

[0098] In some examples, the electrode patterns produced according to the illustrated examples of FIGs. 13 and 14 may be checked to ensure that the random selection of the vertex locations has not inadvertently resulted in an electrode pattern having linear or periodically repeating elements in the electrode pattern, particularly linear elements extending in a direction which may be horizontal, vertical, or at 45° with respect to an orientation of a display which is to be visible through the touch position sensing panel, and vertices or conductive lines which are too closely spaced. This randomization may prevent interference resulting from positioning of the vertices in relation to the pixels of an LCD.

[0099] As discussed regarding the example shown in FIG. 3, a touch position sensing panel may have two electrode layers with respective electrode patterns so that the electrode patterns overlay one another. Any of the examples shown in FIGs. 4 to 14 may be used for either one or both of the electrode layers that may be implemented using narrow metal conductive lines.

[00100] In some examples using mesh metal patterns for both electrode layers, the respective electrode patterns of the two electrode layers may be arranged so that the vertices of one of the electrode patterns are positioned at locations substantially corresponding to centers of mesh cells of the other electrode pattern. As a result of this arrangement of the two electrode patterns, the conductive lines of the two electrode patterns may be distributed more evenly across the touch position-sensing panel. In FIGs. 13 and 14, one of the electrode patterns may have vertex locations determined randomly according to the illustrated examples of FIGs. 13 or 14. The centroids of area of the mesh cells defined by the randomly determined vertex locations of this one of the electrode patterns may define the locations of the vertices of the other electrode patterns.

[00101] For example, the pattern in Fig. 3a may be overlaid with the pattern of Fig. 14, to create a pattern consisting of rhomboid shapes of Fig. 3, the centroids of which are connected by the vertices of the pattern of Fig. 14. Since the connecting lines of Fig. 14 may be generated at the mid point of the lines of Fig. 3, all lines of Fig. 3 run equidistant or in parallel between the lines of Fig. 14 to minimize capacitance. They also intersect at 90 degrees. However, the vertex locations of other electrode patterns may nevertheless be randomly determined, albeit indirectly.

[00102] Arranging for vertices of one of the electrode patterns to be positioned at locations substantially corresponding to centers of mesh cells of the other electrode pattern

may spread the conductive lines more evenly across the touch position sensing panel, and may reduce visible reductions in display brightness.

[00103] In some examples, the respective electrode patterns of the two electrode layers may be arranged so that where conductive lines in the two respective electrode patterns of the two electrode layers cross over one another, the conductive lines cross at an approximately 90° angle. In some examples, it may not be possible to arrange for some conductive lines to cross at a 90° angle and the conductive lines may be arranged to cross at as close to a 90° angle as is practicable. The conductive lines are arranged in curved shapes according to the examples shown in FIGs. 4 to 12. The angle at which conductive lines in the two respective electrode patterns of the two electrode layers cross over may be controlled by adjusting one or more of the wavelength, amplitude and phase of the curved shapes of one or both of the conductive lines.

[00104] Arranging for conductive lines in the two respective electrode patterns of the two electrode layers to cross over one another at, or close to, an approximately 90° angle may reduce mutual capacitance between the conductive lines. Arranging for conductive lines in the two respective electrode patterns of the two electrode layers to cross over one another at, or close to, an approximately 90° angle may prevent two closely spaced parallel or oblique lines to be perceived as a single thicker line. Arranging for conductive lines in the two respective electrode patterns of the two electrode layers to cross over one another at, or close to, an approximately 90° angle may spread the conductive lines more evenly across the touch position sensing panel, and may reduce visible reductions in display brightness.

[00105] In some examples, the respective electrode patterns of the two electrode layers may be arranged so that where conductive lines in the two respective electrode patterns of the two electrode layers cross over one another the phase and/or width of the conductive lines may be controlled according to the examples shown in FIGs. 9 to 12. The cross over point of conductive lines in the respective electrode patterns of the different electrode layers may be treated in a similar way as a connect

[00106] Reducing the width of the conductive lines in the respective electrode patterns in the two electrode layers where the conductive lines cross over may reduce visible reductions in display brightness at the interconnections. Such reductions in display brightness may be visible where constant width conductive lines cross over as there may be a concentration of conductive metal at the cross over point. Reducing the width of the



sinusoidal conductive lines where the sinusoidal conductive lines cross over makes the distribution of the conductive metal across a touch position sensing panel more even, reducing the visibility of differences in display brightness.

[00107] The above examples refer to two electrode layers. The above examples could be extended to only one layer, or to three or more electrode layers. If three or more electrode layers are present, the vertices of the electrode patterns of the different layers may be arranged to spread the vertices approximately evenly across the touch position-sensing panel. Placing the vertices of some of the electrode patterns at locations corresponding to centers of mesh cells of other electrode patterns may not be effective for three or more electrode layers.

[00108] In some examples where a touch position sensing panel is intended to overlay a display having a set display cell size such as an LCD or LED display, the dimensions of the electrode pattern or patterns used may be selected, at least in part, based upon this set cell size of the display. This may allow visual interactions between the display and the touch position sensing panel to be minimized.

[00109] The illustrated examples described above relate to conductor elements and patterns of copper. However, other material may be used. For example, other metals suitable for use as wire pattern material.

[00110] The electrodes discussed above may also be incorporated into devices using a self-capacitance drive approach.

[00111] Various modifications may be made to the examples described in the foregoing, and any related examples may be applied in numerous applications, some of which have been described herein. It is intended by the following claims to claim any and all applications, modifications and variations that fall within the true scope of the present disclosure.

WHAT IS CLAIMED IS:

1. An apparatus comprising:  
an optically clear adhesive (OCA) layer between a cover sheet and a substrate; and  
the substrate, with drive or sense electrodes of a touch sensor disposed on a first surface and a second surface of the substrate, the first surface being opposite the second surface, the drive or sense electrodes being made of a conductive mesh of conductive material comprising metal.
2. The apparatus of Claim 1, further comprising a display separated from the second surface of the substrate by a dielectric layer.
3. The apparatus of Claim 2, wherein the dielectric layer comprises an OCA and cover sheet layer.
4. The apparatus of Claim 1, wherein the conductive material is copper, silver, gold, aluminum, or tin.
5. The apparatus of Claim 1, wherein the conductive mesh comprises a plurality of mesh segments, each of the mesh segments having a width of approximately 10  $\mu\text{m}$ .
6. The apparatus of Claim 5, wherein approximately 5% of an active area of the touch sensor is covered by the one or more mesh segments.
7. The apparatus of Claim 5, wherein each of the mesh segments is substantially sinusoidal.
8. The apparatus of Claim 1, wherein the conductive meshes have an optical transmissivity of approximately 90%.

9. The apparatus of Claim 1, wherein the sense electrodes being disposed on the first surface of the substrate and the drive electrodes being disposed on the second surface of the substrate.

10. An device comprising:  
a cover sheet;  
an optically clear adhesive layer (OCA) between the cover sheet and a substrate;  
the substrate, with drive or sense electrodes of a touch sensor disposed on a first surface and a second surface of the substrate, the first surface being opposite the second surface, the drive or sense electrodes being made of a conductive mesh of conductive material comprising metal; and  
one or more computer-readable non-transitory storage media embodying logic that is configured when executed to control the touch sensor.

11. The device of Claim 10, further comprising a display separated from the second surface of the substrate by a dielectric layer.

12. The device of Claim 10, wherein the dielectric layer comprises an OCA and cover sheet layer.

13. The device of Claim 10, wherein the conductive material is copper, silver, gold, aluminum, or tin.

14. The device of Claim 10, wherein the conductive mesh comprises a plurality of mesh segments, each of the mesh segments having a width of approximately 10  $\mu\text{m}$ .

15. The device of Claim 14, wherein approximately 5% of an active area of the touch sensor is covered by the mesh segments.

16. The device of Claim 14, wherein each of the mesh segments is substantially sinusoidal.

17. The device of Claim 10, wherein the conductive meshes have an optical transmissivity of approximately 90%.

18. The device of Claim 10, wherein the sense electrodes being disposed on the first surface of the substrate and the drive electrodes being disposed on the second surface of the substrate.

19. An apparatus comprising:  
an optically clear adhesive (OCA) layer between a cover sheet and a substrate; and  
the substrate, with sense electrodes of a touch sensor disposed on a first surface and drive electrodes of the touch sensor disposed on a second surface of the substrate, the first surface being opposite the second surface, the drive and sense electrodes being made of a conductive mesh of conductive material comprising metal.

20. The apparatus of Claim 19, further comprising a display separated from the second surface of the substrate by an OCA and cover sheet layer.

ABSTRACT

In one embodiment, an method apparatus includes an optically clear adhesive (OCA) layer between a cover sheet and a substrate. The substrate has drive or sense electrodes of a touch sensor disposed on a first surface and a second surface of the substrate. The first surface is opposite the second surface and the drive or sense electrodes are made of a conductive mesh of conductive material including metal.

FIG. 1

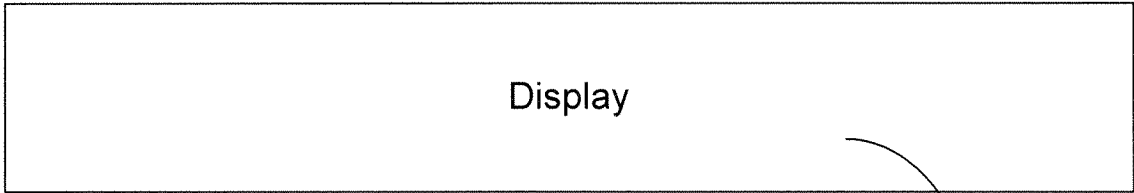
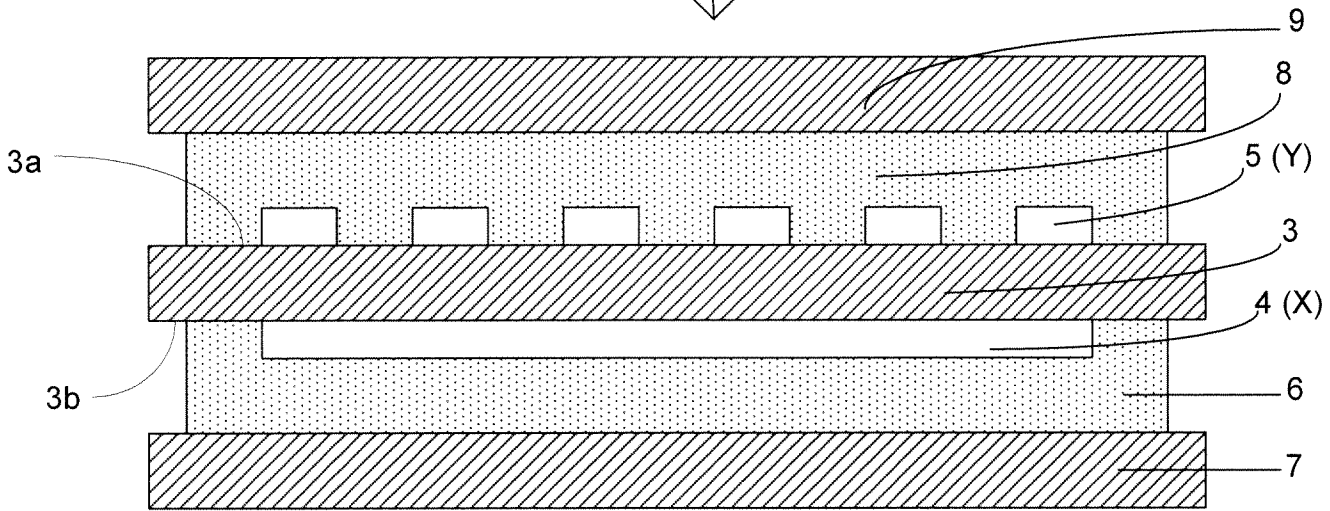

FIG. 2a

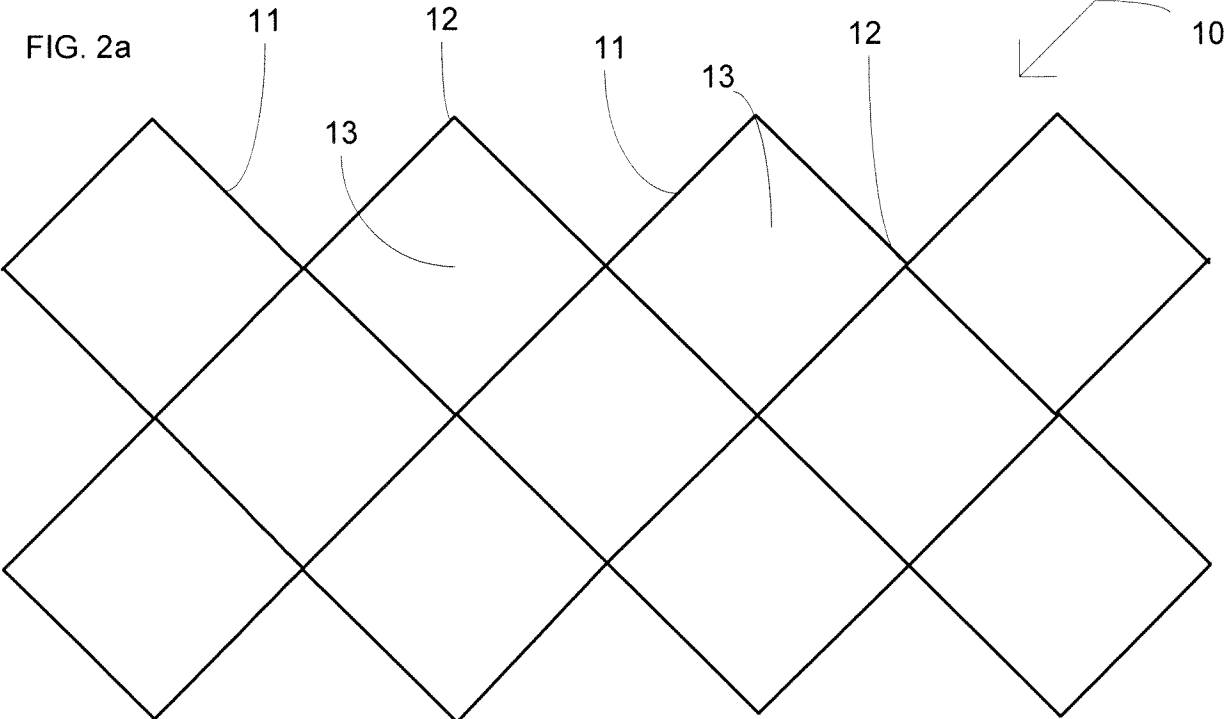

FIG. 2B

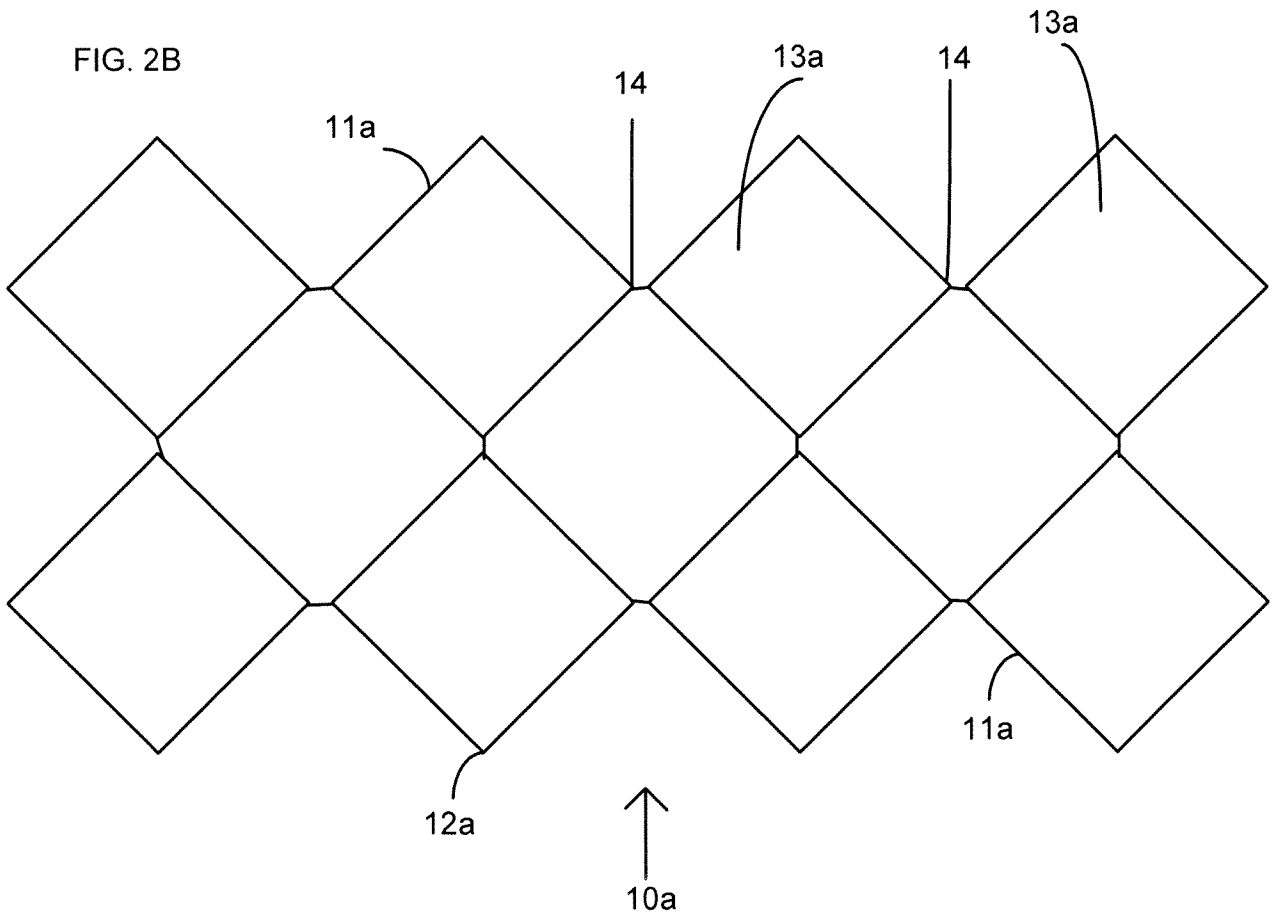



FIG. 3A

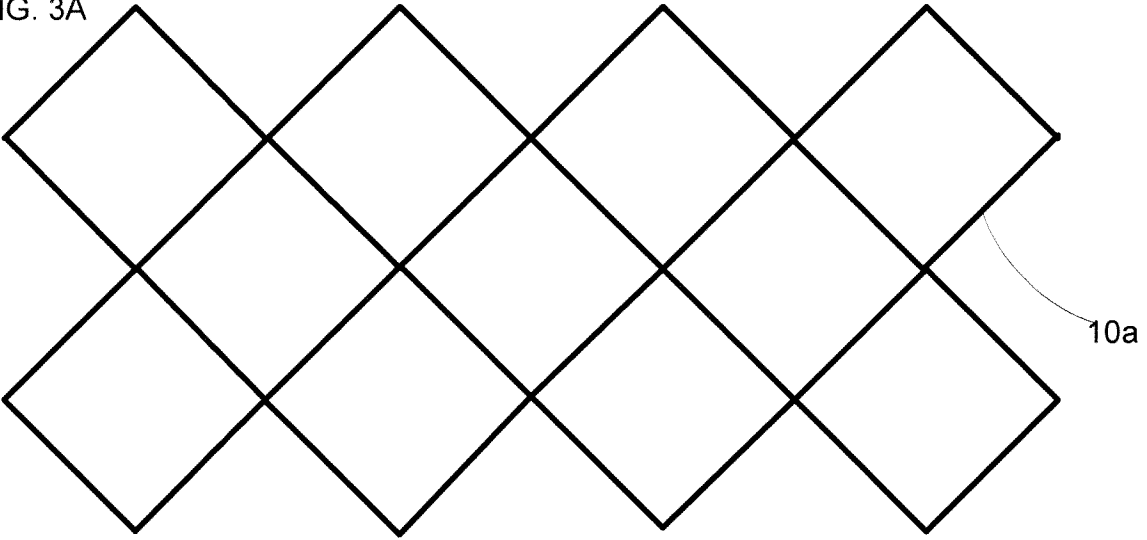

FIG. 3B

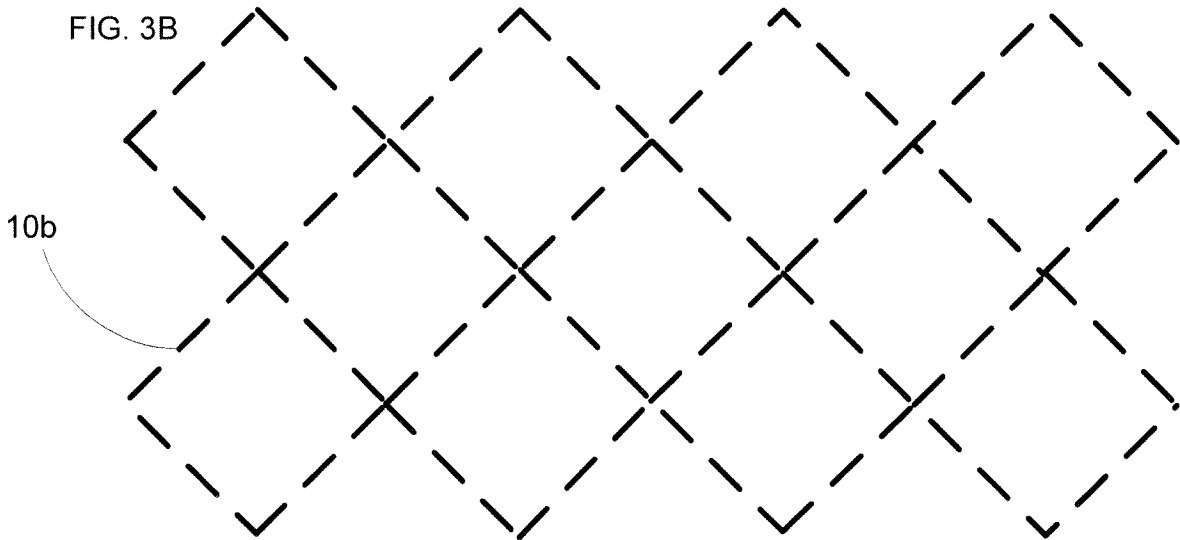

FIG. 3C

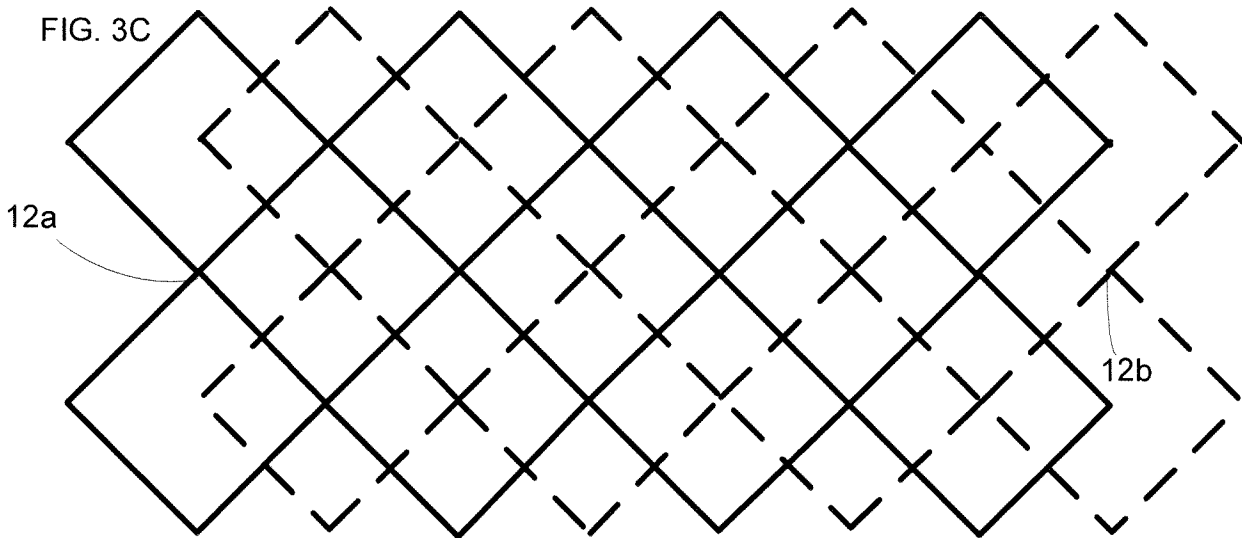

FIG. 4

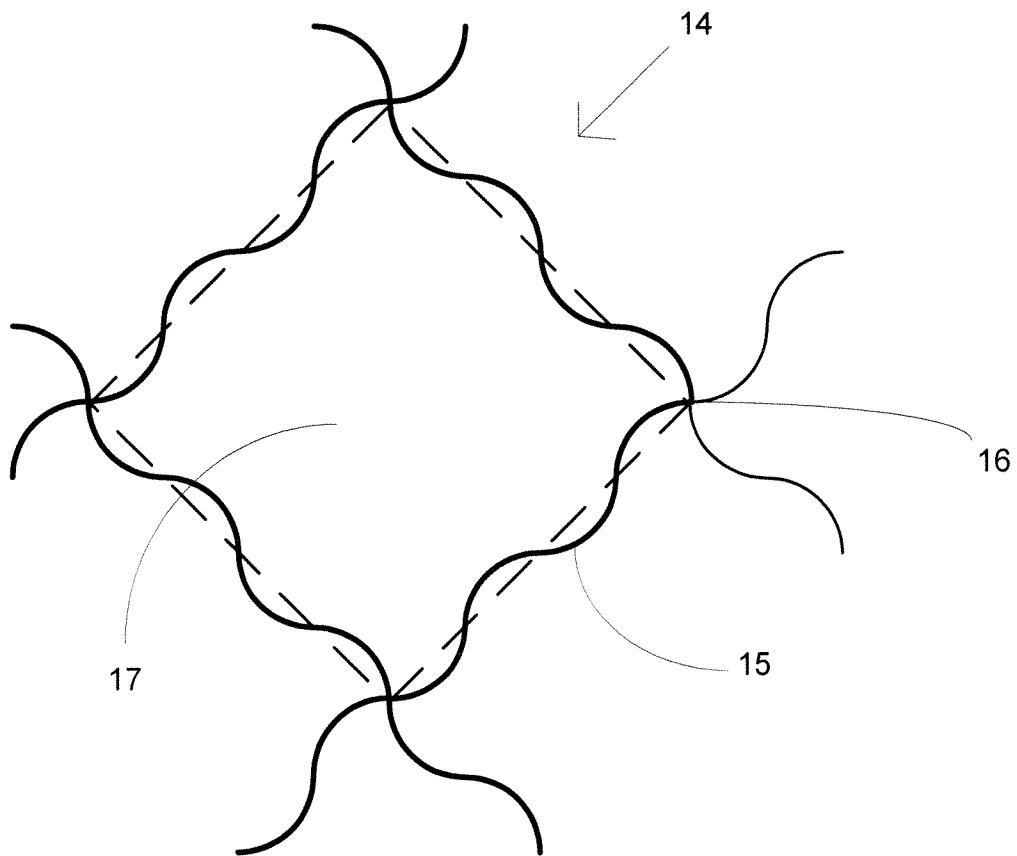
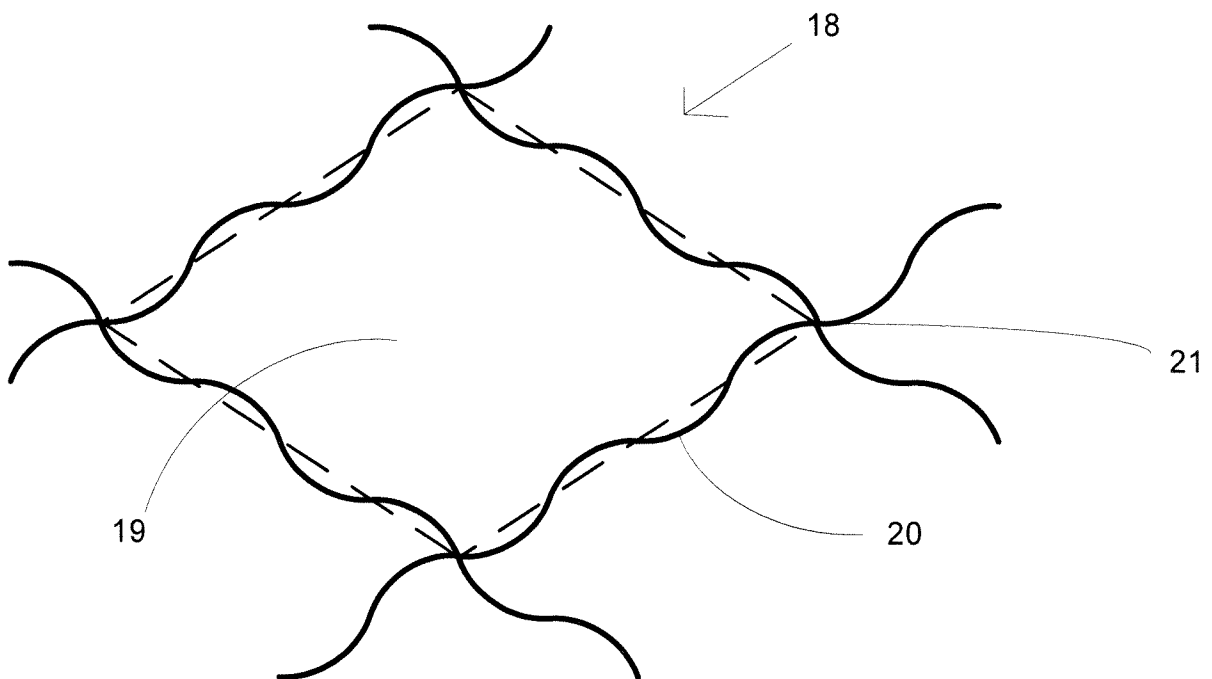

FIG. 5



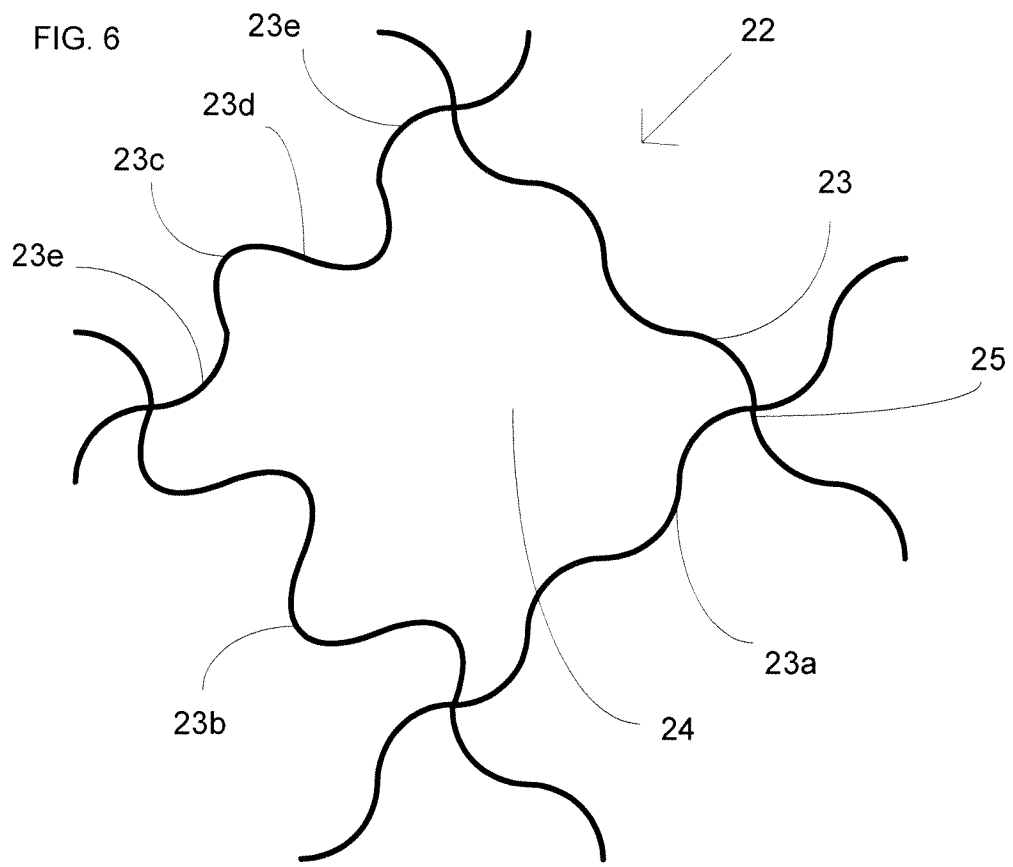
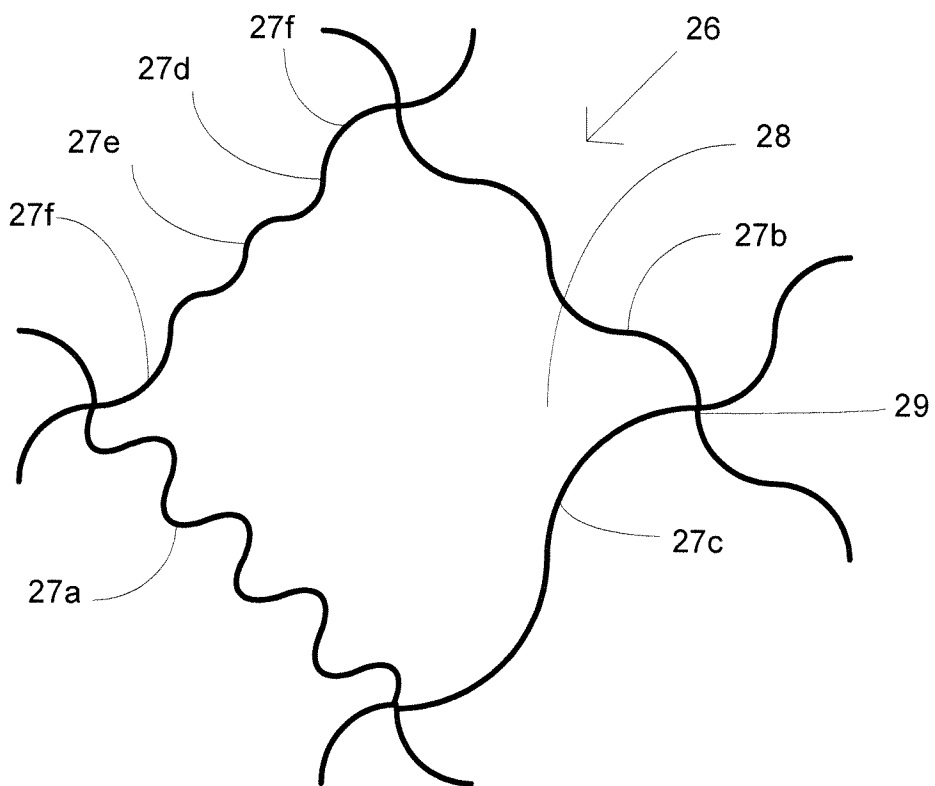

FIG. 7



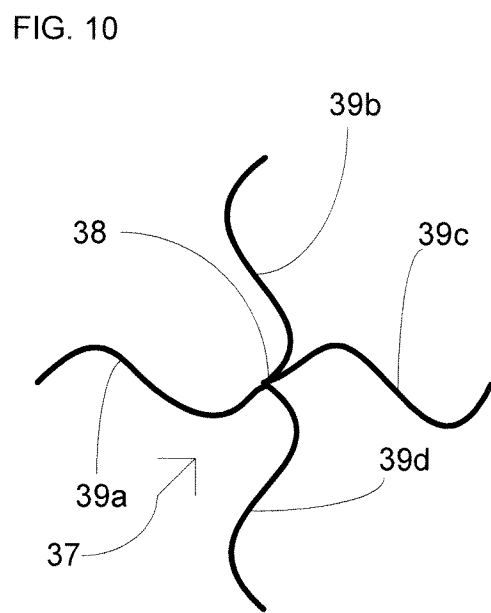
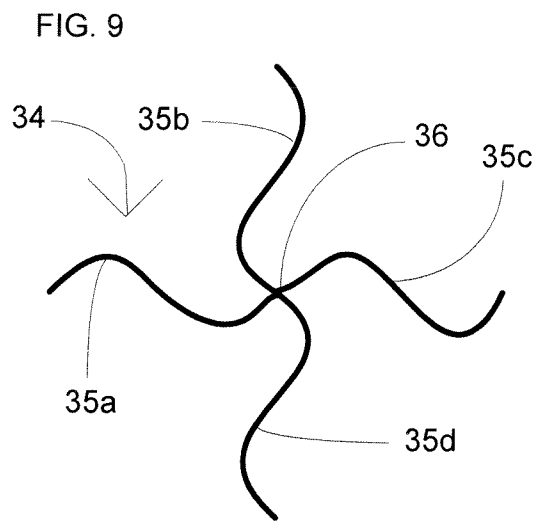
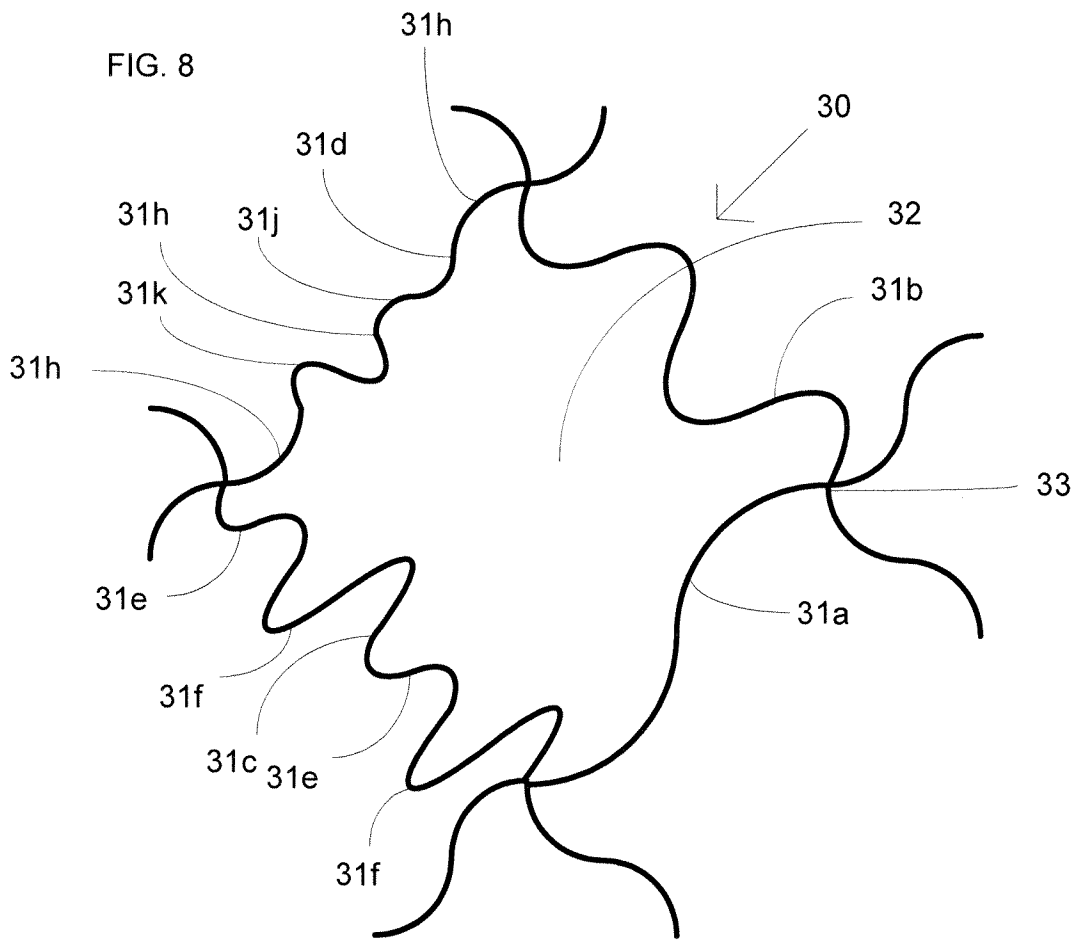

FIG. 11

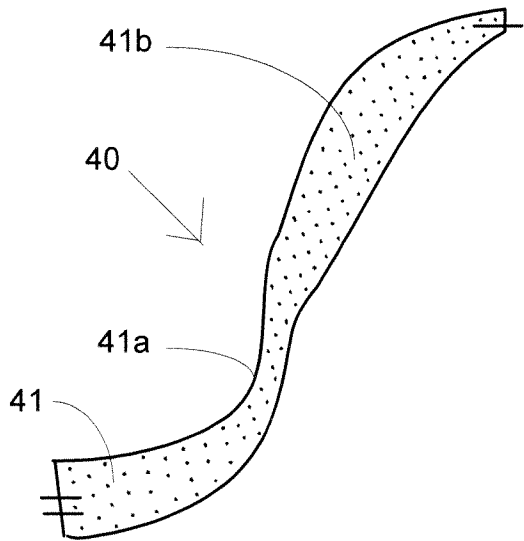

FIG. 12

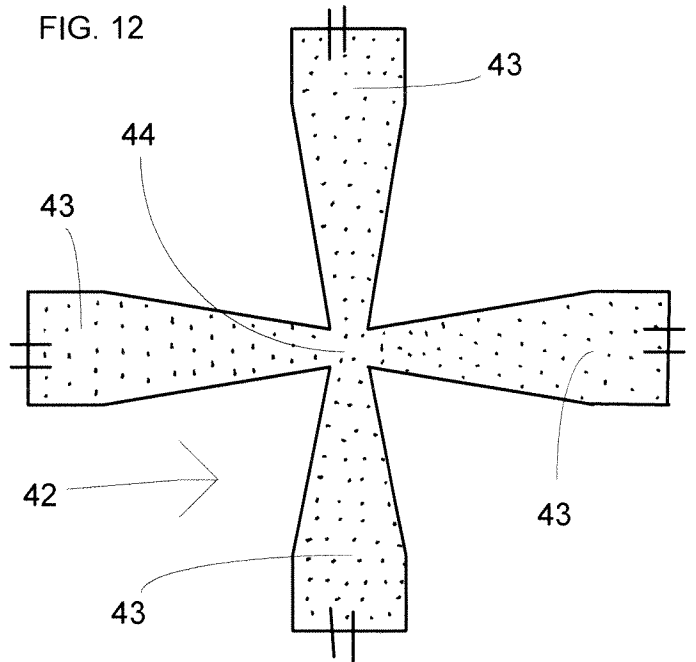

FIG. 13

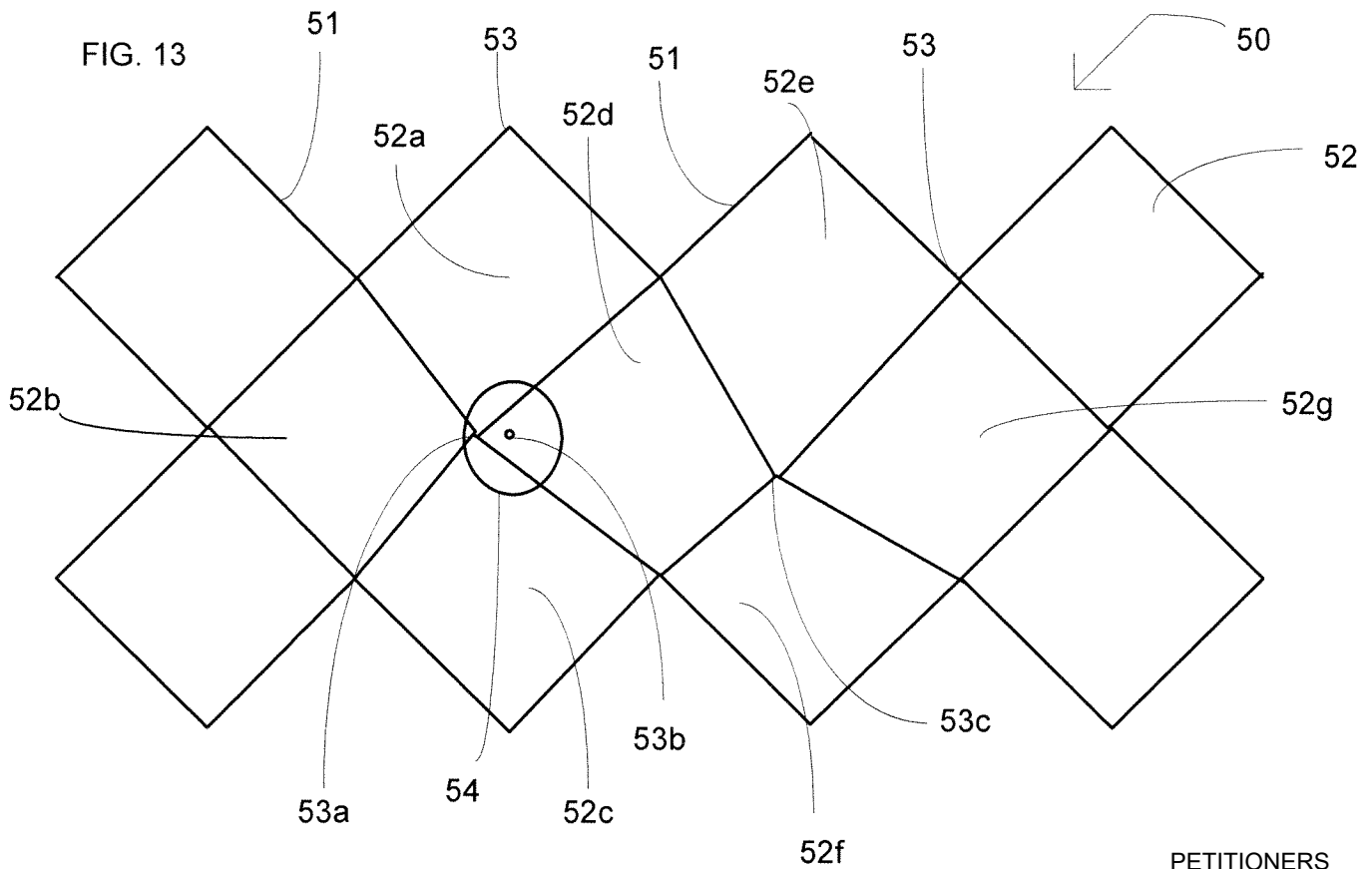
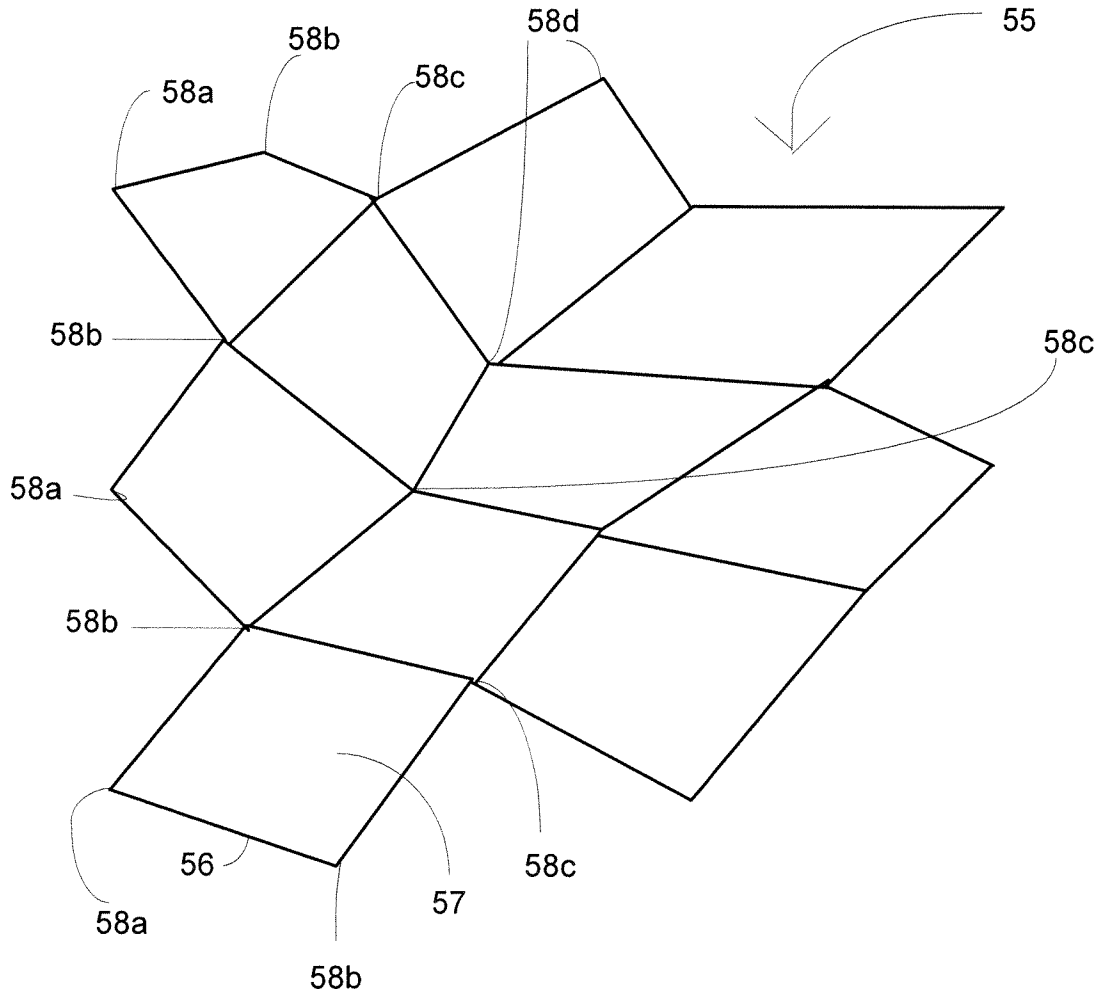

FIG. 14



Atmel Ref: 10045QRG  
Atty Dkt:085111-0191

**DECLARATION**

As a below named inventor, I hereby declare that:

My residence, mailing address and citizenship are as stated below next to my name,

I believe I am the original, first and sole inventor (if only one name is listed below) or an original, first and joint inventor (if plural names are listed below) of the subject matter claimed and for which a patent is sought on the invention entitled **PANEL**, the specification of which

is attached hereto.

was filed on \_\_\_\_\_ as United States Application \_\_\_\_\_, or PCT International Application \_\_\_\_\_ and was amended on \_\_\_\_\_ (if applicable), or

is a Continuation-In-Part (CIP) of Application \_\_\_\_\_, filed \_\_\_\_\_

I hereby state that I have reviewed and understand the contents of the above identified specification, including the claims, as amended by any amendment referred to above.

I acknowledge the duty to disclose information which is known to me to be material to patentability as defined in Title 37, Code of Federal Regulations, Section 1.56 including for continuation-in-part applications, material information which became available between the filing date of the prior application and the national or PCT international filing date of the continuation-in-part application.

I hereby claim foreign priority benefits under 35, United States Code, Section 119(a)-(d) or (f), or 365(b) of any foreign application(s) for patent or inventor's or plant breeder's right certificate, or 365(a) of any PCT international application which designated at least one country other than the United States of America, listed below and have also identified below any foreign application for patent or inventor's, or plant breeder's rights certificate, or any PCT international application having a filing date before that of the application on which priority is claimed:

**Prior Foreign Applications(s):**

Number	Country	Day/Month/Year filed	Priority Claimed
			<input type="checkbox"/>
			<input type="checkbox"/>

I hereby claim the benefit under 35 United States Code, Section 119(e) of any United States provisional application(s) listed below.

**Prior Provisional Application(s):**

Application Number	Filing Date
--------------------	-------------

I hereby claim the benefit under 35, United States Code, Section 120 of any United States application(s) or 365(c) of any PCT international application designating the United States, listed below and, insofar as the subject matter of each of the claims of this application is not disclosed in the prior United States or PCT international application in the manner provided by the first paragraph of 35, United States Code, Section 112. I acknowledge the duty to disclose information which is material to patentability as defined in 37, Code of Federal Regulations, Section 1.56 which occurred between the filing date of the prior application and the national or PCT international filing date of this application:

**Prior U.S. Application(s):**

Application No.

Filing Date

Status: Patented, Pending, Abandoned

I hereby declare that all statements made herein of my own knowledge are true and that all statements made on information and belief are believed to be true; and further that these statements were made with the knowledge that willful false statements and the like so made are punishable by fine or imprisonment, or both, under Section 1001 of Title 18 of the United States Code and that such willful false statements may jeopardize the validity of the application or any patent issued thereon.

---

**Full name of first inventor:** David Brent Guard

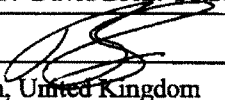
Inventor's signature: 

Date: 18 APR 2011

Residence: Southampton, United Kingdom

Citizenship: United Kingdom

Post Office Address: ATMEL UK

1560 Parkway, Solent Business Park  
Whiteley, Fareham, Hampshire PO15 7AG  
United Kingdom

---

**Inventor Two:** Esat Yilmaz

Inventor's signature: 

Date: 14 APR 2011

Residence: Santa Cruz, CA

Citizenship: United Kingdom

Post Office Address: ATMEL Corporation  
2325 Orchard Parkway  
San Jose, CA 95131  
United States

---

**Inventor Three:** Tsung-Ching Wu

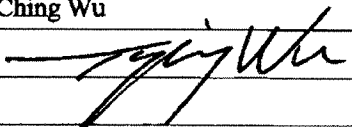
Inventor's signature: 

Date: April 14, 2011

Residence: Saratoga, CA

Citizenship: US

Post Office Address: ATMEL Corporation  
2325 Orchard Parkway  
San Jose, CA 95131  
United States