



- [54] **SPREAD SPECTRUM TIME DIVERSITY COMMUNICATIONS SYSTEM**
- [75] Inventor: **Ichiro Tsujimoto**, Tokyo, Japan
- [73] Assignee: **NEC Corporation**, Tokyo, Japan
- [21] Appl. No.: **09/018,893**
- [22] Filed: **Feb. 5, 1998**

Related U.S. Application Data

- [62] Division of application No. 08/620,246, Mar. 22, 1996, Pat. No. 5,757,853.

Foreign Application Priority Data

- Mar. 22, 1995 [JP] Japan 7-062821
- [51] **Int. Cl.⁷** **H04B 1/707**
- [52] **U.S. Cl.** **375/143; 375/152**
- [58] **Field of Search** 375/140, 141, 375/142, 143, 147, 150, 152; 370/320, 335, 342, 441

References Cited

U.S. PATENT DOCUMENTS

- 5,461,610 10/1995 Weerackody 375/146
- 5,471,497 11/1995 Zehavi 375/142
- 5,677,929 10/1997 Asano et al. 375/141

Primary Examiner—Don N. Vo
Attorney, Agent, or Firm—Sughrue, Mion, Zinn, Macpeak & Seas, PLLC

[57] **ABSTRACT**

In a time diversity radio communications system, quadrature-modulated spread spectrum signals of different mutual time delay are combined into a code division multiplex signal and up-converted to a radio-frequency signal and transmitted. At a receive site, the signal is received by an antenna and down-converted to recover the code division multiplex signal. Quadrature-modulated component signals contained in the recovered code division multiplex signal are converted to baseband signals which are then time-aligned with each other. The time-aligned baseband signals are multiplied respectively by complex weighting factors and are combined together to produce an input signal for an adaptive equalizer. This input signal is also applied to an AGC amplifier where it is amplified and applied to correlation detectors where correlations between the amplified signal and the baseband signals are detected and the complex weighting factors are derived respectively from the correlations. In a modified embodiment, the quadrature-modulated component signals are fed into an adaptive RAKE matched filter where the output of the AGC amplifier is used for detecting the correlations.

7 Claims, 5 Drawing Sheets

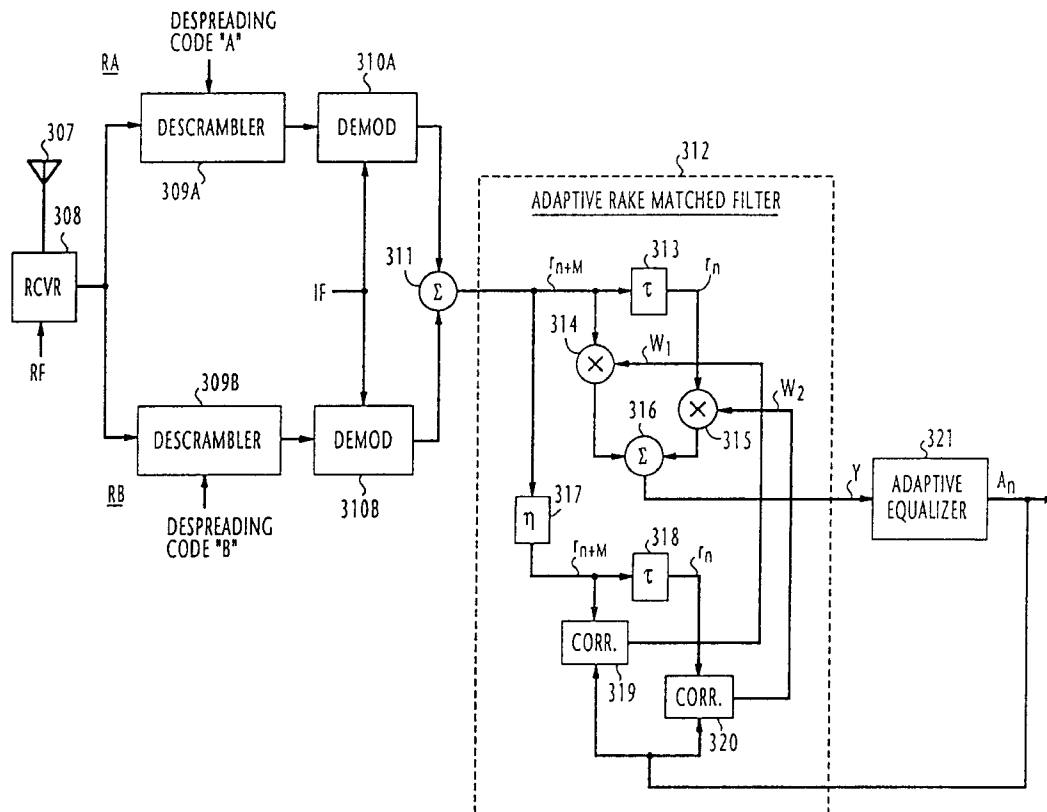

FIG. 1A

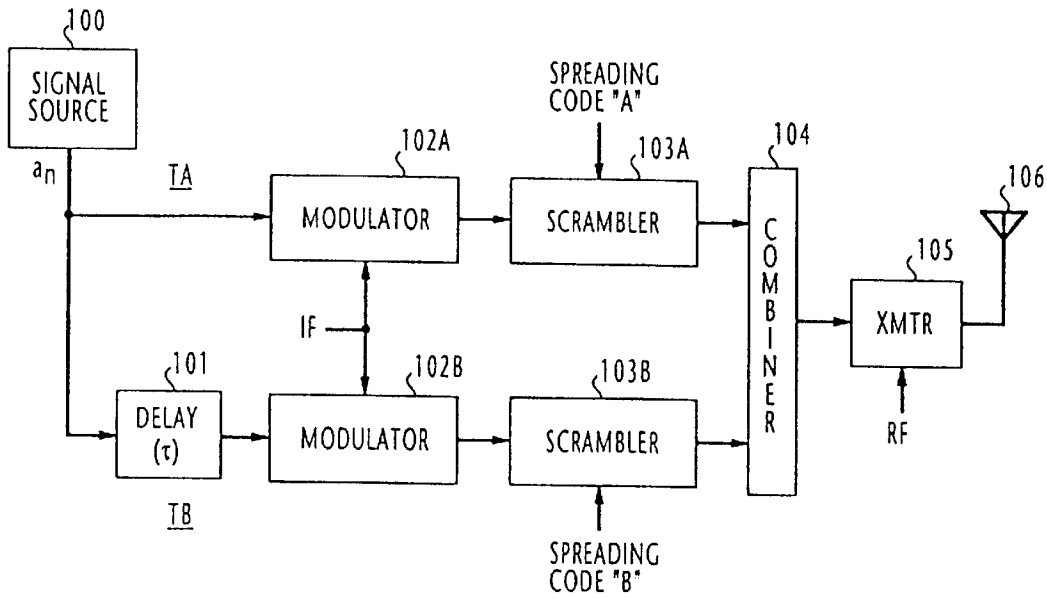

FIG. 1B

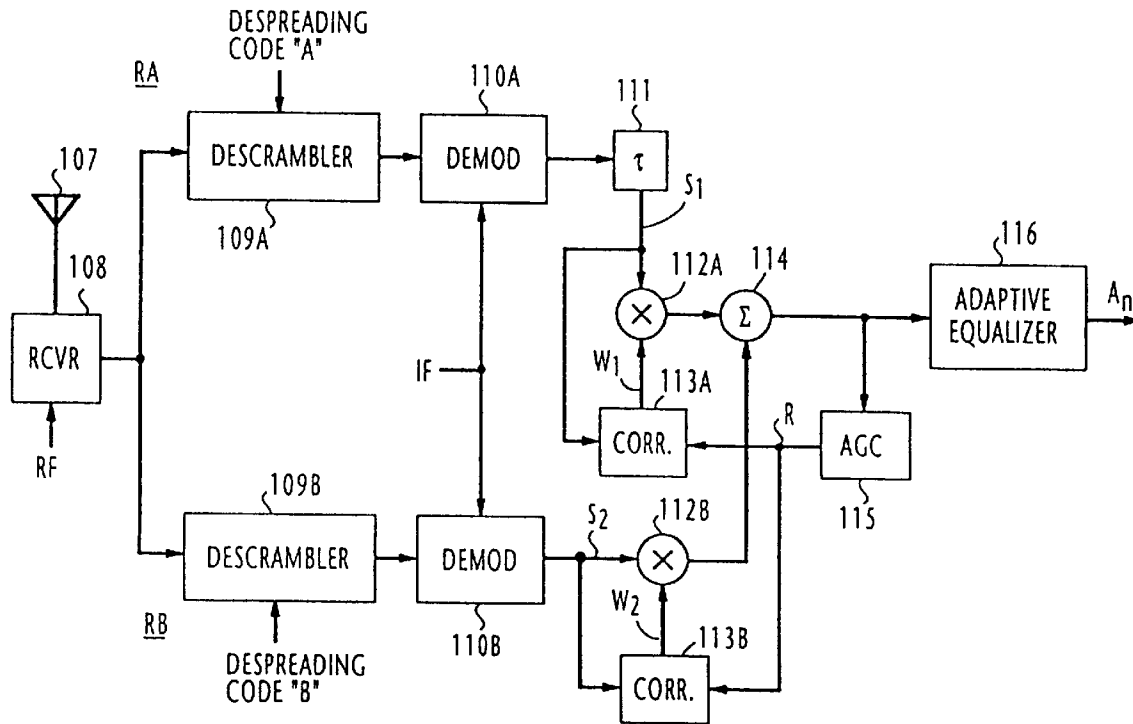

FIG. 2

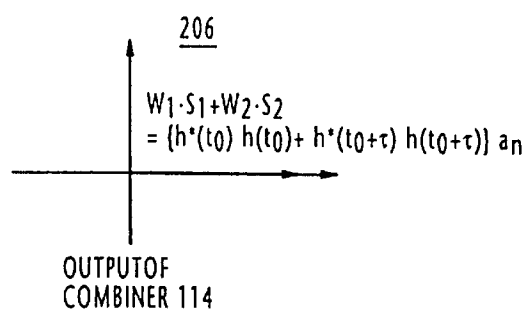
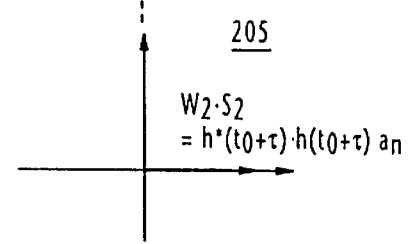
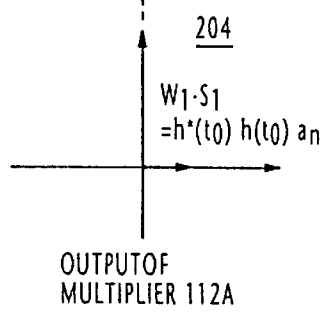
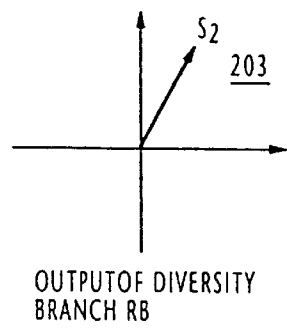
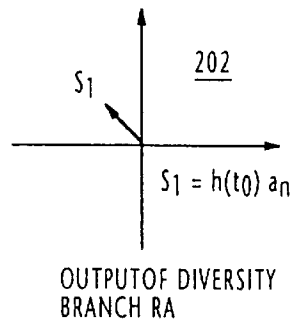
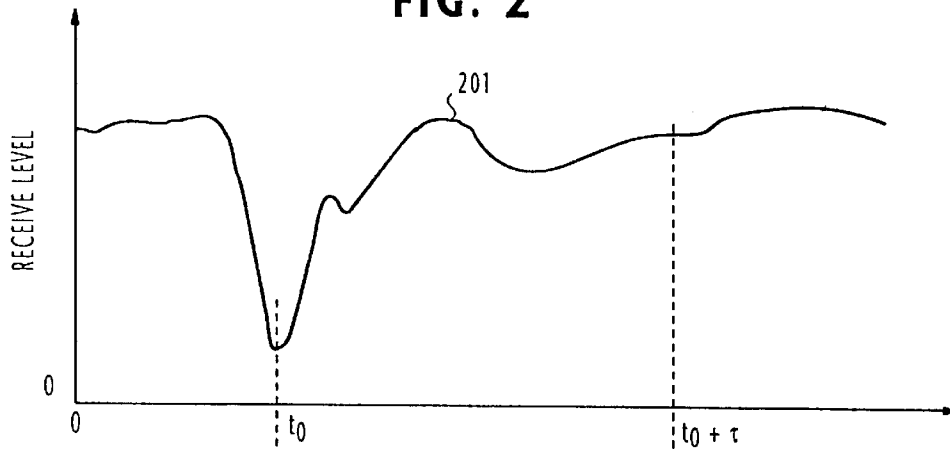

FIG. 3A

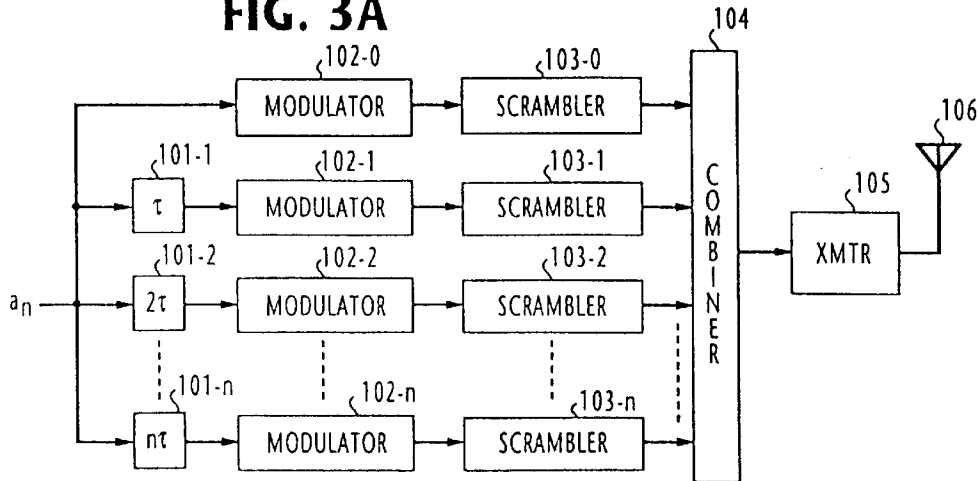
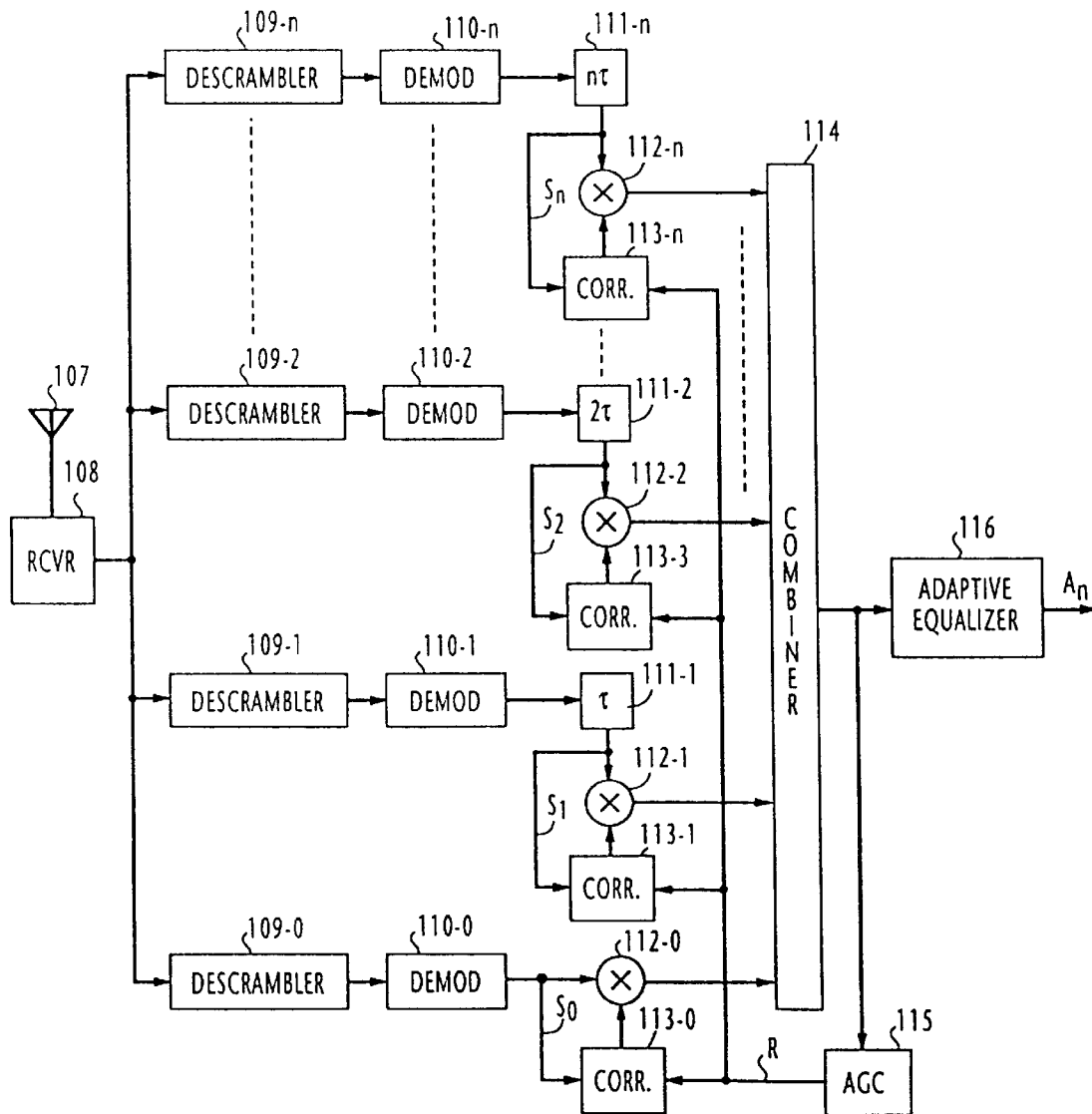

FIG. 3B



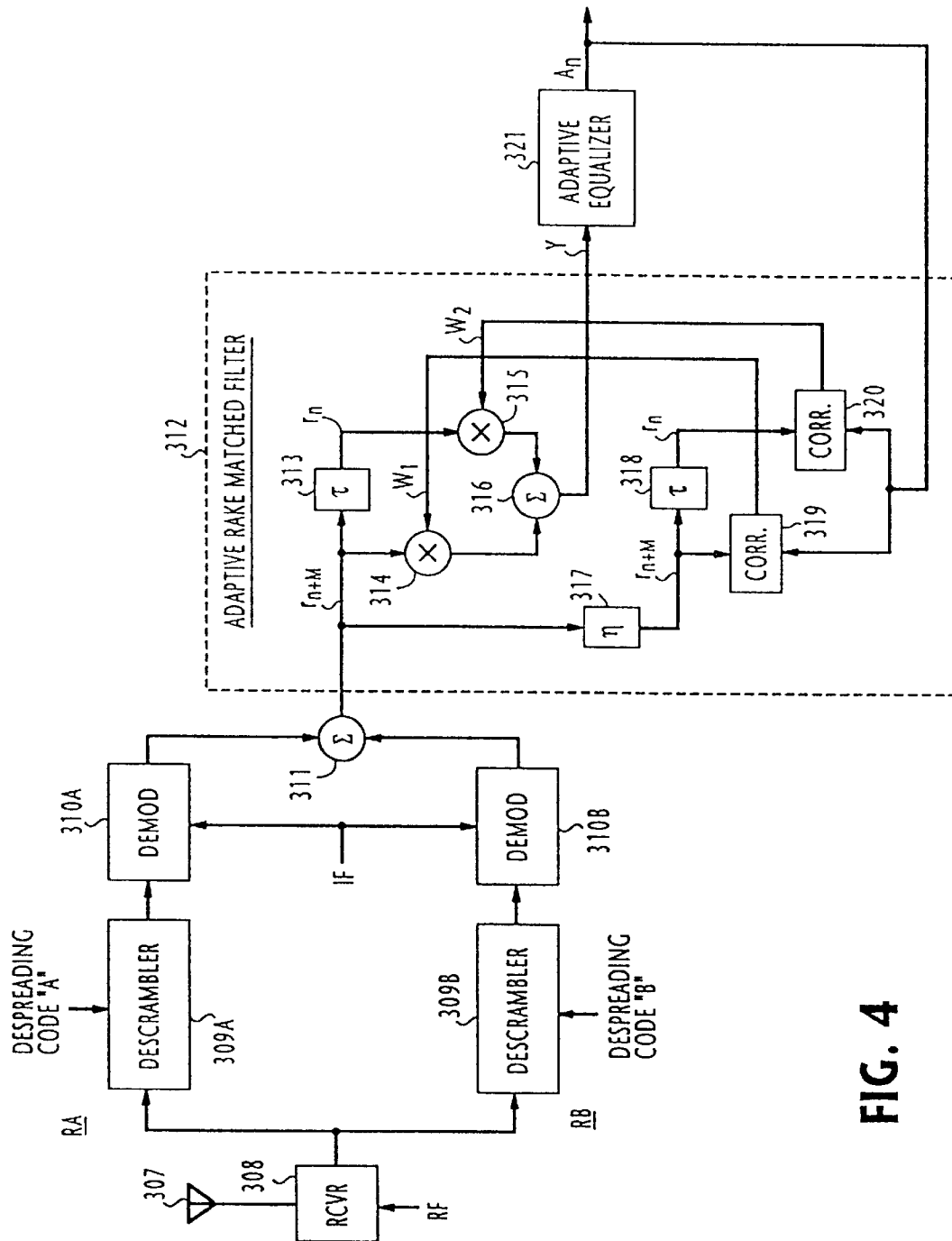

FIG. 4

Explore Litigation Insights

Docket Alarm provides insights to develop a more informed litigation strategy and the peace of mind of knowing you're on top of things.

Real-Time Litigation Alerts



Keep your litigation team up-to-date with **real-time alerts** and advanced team management tools built for the enterprise, all while greatly reducing PACER spend.

Our comprehensive service means we can handle Federal, State, and Administrative courts across the country.

Advanced Docket Research



With over 230 million records, Docket Alarm's cloud-native docket research platform finds what other services can't. Coverage includes Federal, State, plus PTAB, TTAB, ITC and NLRB decisions, all in one place.

Identify arguments that have been successful in the past with full text, pinpoint searching. Link to case law cited within any court document via Fastcase.

Analytics At Your Fingertips



Learn what happened the last time a particular judge, opposing counsel or company faced cases similar to yours.

Advanced out-of-the-box PTAB and TTAB analytics are always at your fingertips.

API

Docket Alarm offers a powerful API (application programming interface) to developers that want to integrate case filings into their apps.

LAW FIRMS

Build custom dashboards for your attorneys and clients with live data direct from the court.

Automate many repetitive legal tasks like conflict checks, document management, and marketing.

FINANCIAL INSTITUTIONS

Litigation and bankruptcy checks for companies and debtors.

E-DISCOVERY AND LEGAL VENDORS

Sync your system to PACER to automate legal marketing.