

(12) **United States Patent**
Smith et al.

(10) **Patent No.:** **US 6,289,203 B1**
 (45) **Date of Patent:** **Sep. 11, 2001**

- (54) **METHOD OF CALCULATING SIGNAL PROPAGATION LOSS AND CREATING A DATA BASE THEREFOR**
- (75) Inventors: **Jack Anthony Smith**, Bedford; **John Douglas Reed**, Arlington; **Adam Dewhirst**, Austin, all of TX (US)
- (73) Assignee: **Motorola, Inc.**, Schaumburg, IL (US)
- (*) Notice: Subject to any disclaimer, the term of this patent is extended or adjusted under 35 U.S.C. 154(b) by 0 days.

1996 IEEE 46th Vehicular Technology Conference Proceedings, vol. 3, IEEE Service Center, 445 Hoes Lane, PO Box 1331, Piscataway, NJ 08855, Cat. Nos.: 96CH35894, 96CB35894.

Wireless Communications Principles and Practice, by T. S. Rappaport, pp. 110–120, 1996, Prentice Hall, upper Saddle River, New Jersey 07458.

* cited by examiner

- (21) Appl. No.: **09/030,091**
- (22) Filed: **Feb. 25, 1998**
- (51) Int. Cl.⁷ **H04Q 7/20**
- (52) U.S. Cl. **455/67.1; 455/423**
- (58) Field of Search **455/67.1, 67.3, 455/67.4, 67.5, 67.7, 423, 446**

Primary Examiner—Daniel S. Hunter
Assistant Examiner—Myron K. Wyche
 (74) *Attorney, Agent, or Firm*—Sayed Hossain Beladi; Mario J. Donato, Jr.

(57) **ABSTRACT**

A method for determining a final propagation loss of a signal transmitted from a transmitter (302) and received at a receiver (303) located in a proximity of a road (340) in a predefined area (350) includes calculating an environmental factor based on a transportation network information associated with predefined area (350), and determining the final propagation loss based on the environmental factor. A method of creating a data base used for calculating the propagation loss includes providing a preliminary data base, calculating a road density constant based on a road profile of predefined area (350), calculating a road constant based on a road classification profile of road (340), calculating the environmental factor by summing the road density constant, and the road constant, and modifying the preliminary data base according to the environmental factor to produce the data base.

(56) **References Cited**

U.S. PATENT DOCUMENTS

5,179,722	*	1/1993	Gunmar et al.	455/67.7
5,491,644	*	2/1996	Pickering et al.	455/67.4
5,561,841	*	10/1996	Markus	455/67.7
5,828,960	*	10/1998	Tang et al.	455/466
5,953,669	*	9/1999	Stratis et al.	455/67.3

OTHER PUBLICATIONS

Net Plan RF Engineering User's Manual, Release 3.1, 1197, Motorola Inc.
 Census Feature Class Codes, tiger/line files, 1995 Technical Documentation, Bureau of the Census, Washington DC, 1996.

13 Claims, 3 Drawing Sheets

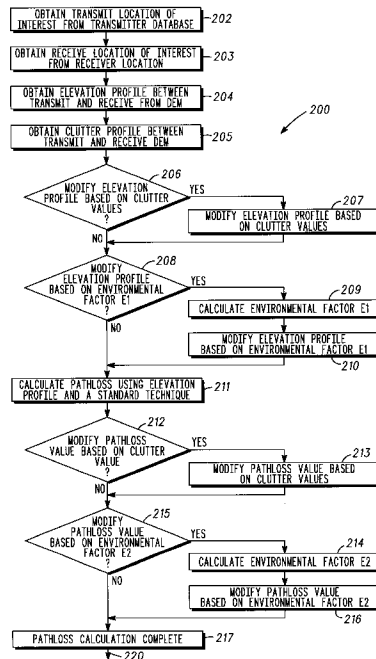

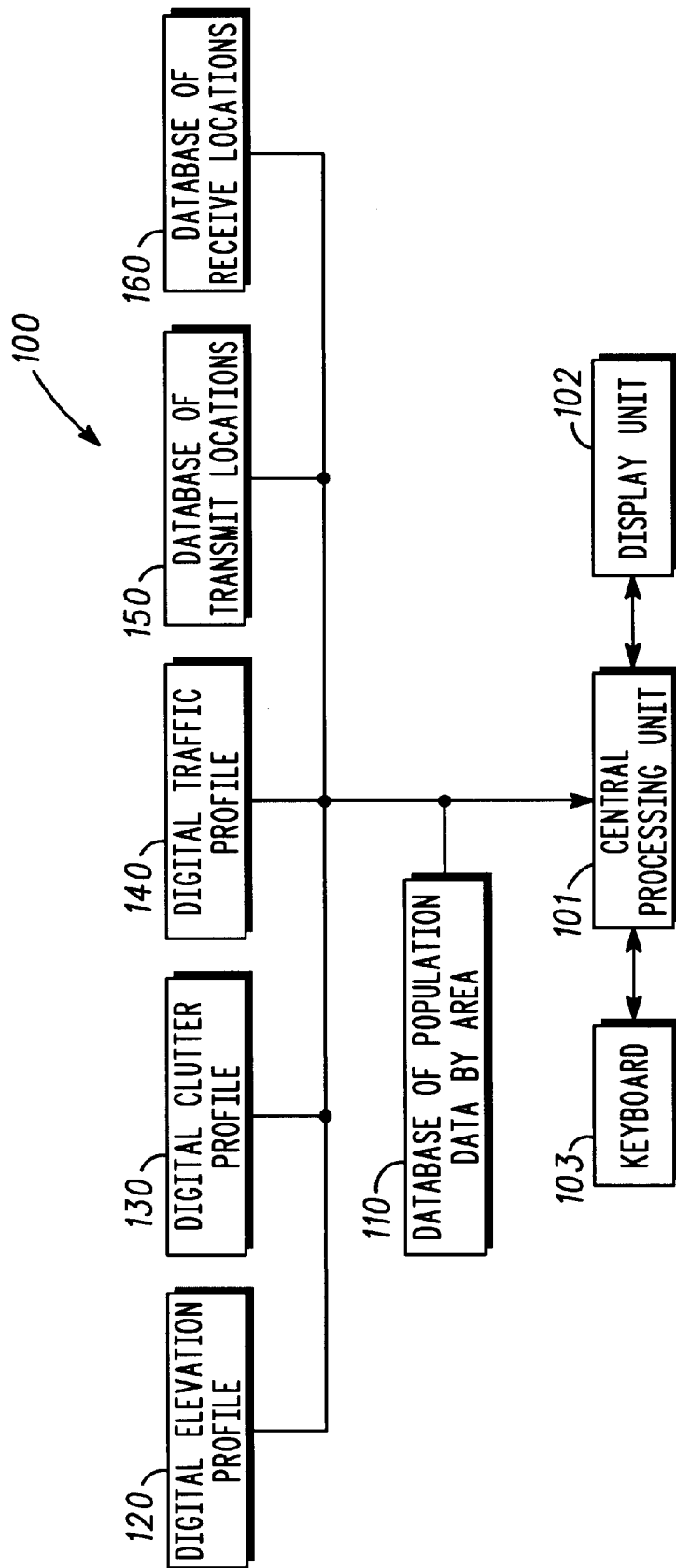
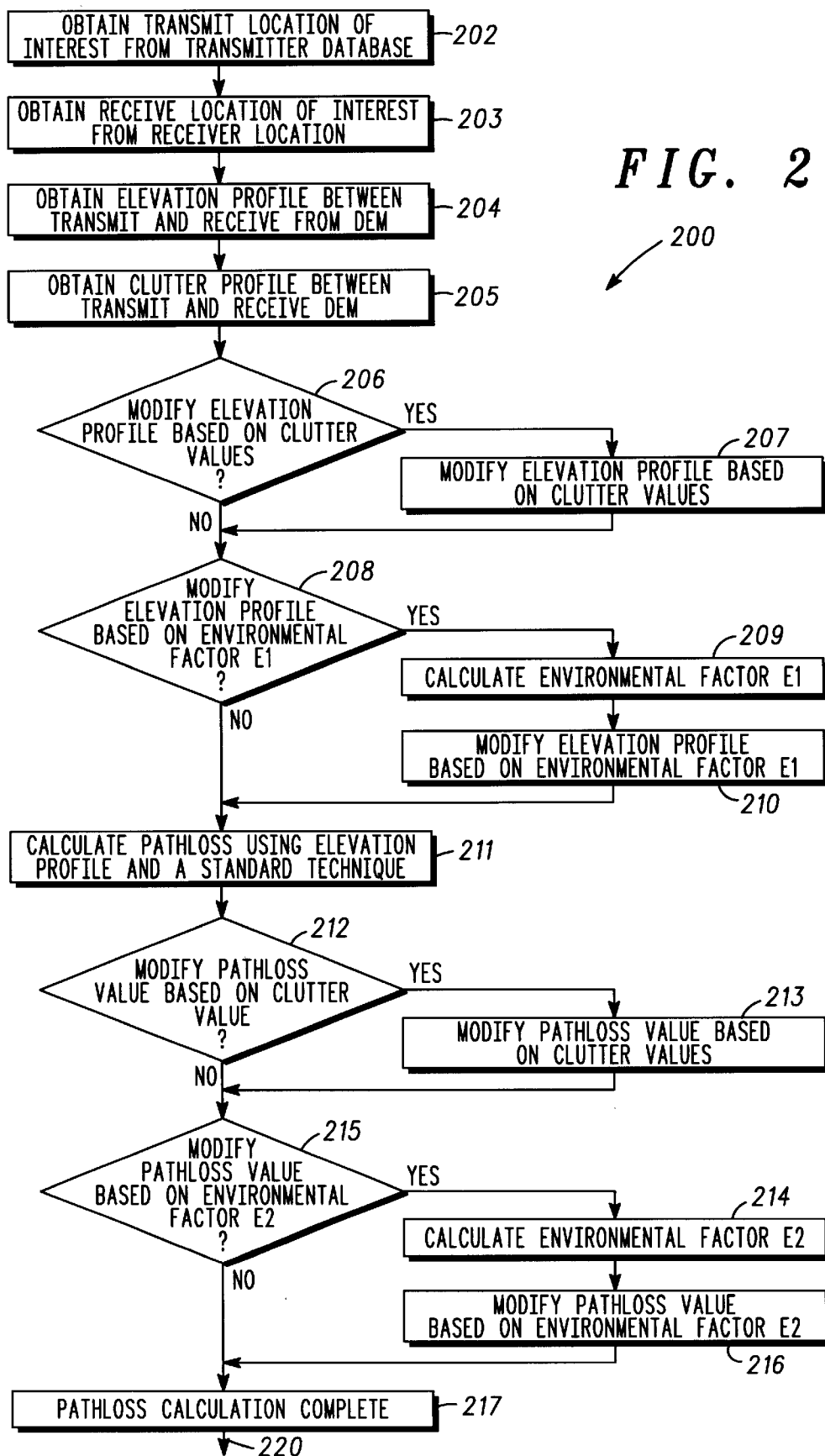

FIG. 1



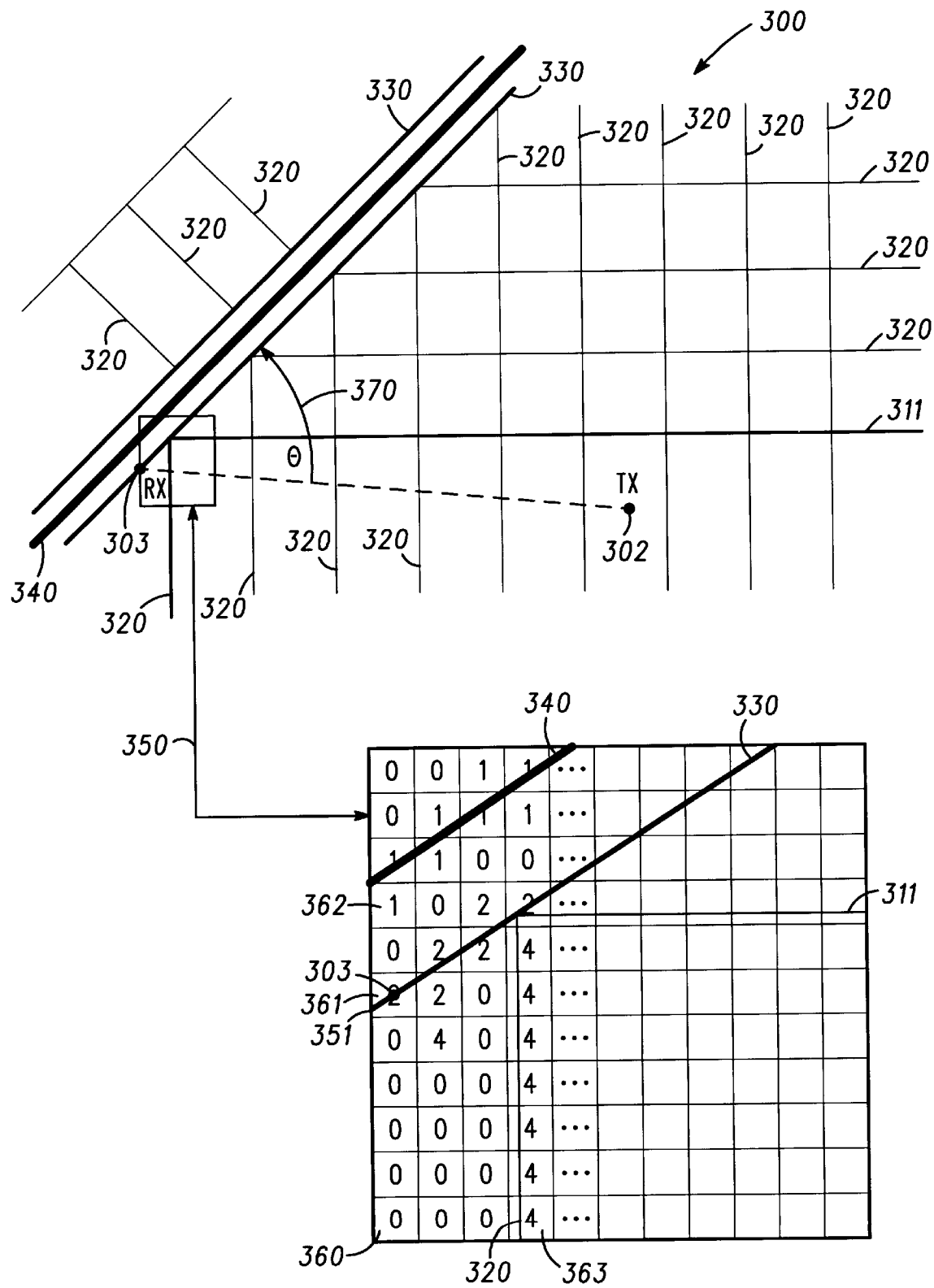

FIG. 3

METHOD OF CALCULATING SIGNAL PROPAGATION LOSS AND CREATING A DATA BASE THEREFOR

FIELD OF THE INVENTION

The present invention generally relates to a method of calculating propagation loss of a signal and creating a data base therefor.

BACKGROUND OF THE INVENTION

A wireless communication system normally spans its coverage over a wide geographical area. A controller of the communication system maintains an efficient communication system operation by utilizing propagation loss characteristics of the coverage area to calculate a transmitted power level of various transmitters in the coverage area. In addition, propagation loss characteristics are used for initial system layout, system modifications, system rearrangements, site specific parameter adjustments, and adding or eliminating system base station sites. The propagation loss characteristic is affected by terrain of the coverage area. The terrain is very often comprised of different categories of terrain irregularities, and some these irregularities change over time. The terrain irregularities normally are in the form of man-made objects such as buildings, bridges, towers, roads and cars, and natural objects, such as hills, mountains, and trees.

Terrain irregularities have often been given names, such as clutter, and elevation irregularities. Such irregularities are stored in one or more data profiles. The clutter profile generally includes data about objects on the earth's surface such as homes, buildings, trees, and agricultural crops. The United States Geological Survey has categorized the clutter information in many categories and sub-categories. The clutter profile of the coverage area changes more often than the elevation profile. Clutter profile changes very often because man and nature effect the clutter characteristic much easier in a short period of time than the elevation characteristic. When the characterization of the propagation environment is based on an outdated clutter profile, the results are adversely affected. For example, inaccurate signal propagation characterization causes the wireless communication system to operate in a less efficient capacity, resulting in a less optimal system layout design.

Since clutter profiles are expensive, and gathered by time-consuming aerial and land surveys of the coverage area, an up-to-date clutter profile often is unavailable. As such, there is a need for a method of efficiently characterizing a propagation environment without reliance on up-to-date clutter information, and creating a data base therefor.

BRIEF DESCRIPTION OF THE DRAWINGS

FIG. 1 depicts a block diagram of a computer system having access to data bases for calculating propagation loss of a signal according to various embodiments of the present invention.

FIG. 2 depicts various combinations of a method for calculating propagation loss of a signal, and creating a data base therefore according to various embodiments of the present invention.

FIG. 3 depicts a transportation network and its elements for calculating an environmental factor according to various embodiments of the present invention.

DETAILED DESCRIPTION OF THE PREFERRED EMBODIMENTS

According to an embodiment of the present invention, a propagation loss of a signal transmitted from a transmitter

and received at a receiver is determined. The receiver in particular is in a predefined area. The predefined area has an elevation profile and a clutter profile. The predefined area may include one or more roads. At first, an environmental factor is calculated based on a road density, a population density, a road constant and a road orientation constant, all associated with the predefined area. In particular, the road constant is based on a predefined road class normally found in the predefined area. The road orientation constant is based on an angle of the signal propagation direction from the transmitter to the receiver and a direction of the road where the receiver has an adequate proximity. The elevation profile is modified according to the environmental factor to produce a modified elevation profile. Finally, the propagation loss is determined based on the modified elevation profile and the clutter profile. In addition to the step of modifying the elevation profile according to the environmental factor, the elevation profile may be modified according to the clutter profile. As an advantage of the present invention, any adverse effect of the clutter profile inaccuracy, due to its possible outdated data, accordingly is reduced. Such a result is possible by a propagation loss determination that is based on the modified elevation profile data.

In another embodiment of the present invention, a propagation loss of a signal transmitted from a transmitter and received at a receiver is determined. The receiver in particular is in a predefined area. The area has an elevation profile and a clutter profile. The predefined area may include one or more roads. At first, an environmental factor is calculated based on a road density, a population density, a road constant and a road orientation constant, all associated with the predefined area. In particular, the road constant is based on a predefined road class normally found in the predefined area. The road orientation constant is based on an angle of the signal propagation direction from the transmitter to the receiver and a direction of a road where the receiver has an adequate proximity. A preliminary propagation loss is determined based on the elevation profile and the clutter profile. Then, the preliminary propagation loss is modified according to the environmental factor to produce the propagation loss. In addition to the step of modifying the preliminary propagation loss according to the environmental factor, the preliminary propagation loss may be modified according to the clutter profile. As an advantage of the present invention, any adverse effect of the clutter profile inaccuracy, due to its possible outdated data, accordingly is reduced. Such a result is possible by a propagation loss determination where its preliminary propagation loss is modified according to the environmental factor.

In another embodiment of the present invention, a propagation loss of a signal transmitted from a transmitter and received at a receiver is determined. The receiver particularly is in a predefined area. The area has an elevation profile and a clutter profile. The predefined area may include one or more roads. At first, a first and second environmental factors are calculated based on a road density, a population density, a road constant and a road orientation constant, all associated with the predefined area. In particular, the road constant is based on a predefined road class normally found in the predefined area. The road orientation constant is based on an angle of the signal propagation direction from the transmitter to the receiver and a direction of a road where the receiver has an adequate proximity. The elevation profile is modified according to the first environmental factor to produce a modified elevation factor. A preliminary propagation loss is determined based on the modified elevation factor and the clutter profile. The preliminary propagation

Explore Litigation Insights

Docket Alarm provides insights to develop a more informed litigation strategy and the peace of mind of knowing you're on top of things.

Real-Time Litigation Alerts



Keep your litigation team up-to-date with **real-time alerts** and advanced team management tools built for the enterprise, all while greatly reducing PACER spend.

Our comprehensive service means we can handle Federal, State, and Administrative courts across the country.

Advanced Docket Research



With over 230 million records, Docket Alarm's cloud-native docket research platform finds what other services can't. Coverage includes Federal, State, plus PTAB, TTAB, ITC and NLRB decisions, all in one place.

Identify arguments that have been successful in the past with full text, pinpoint searching. Link to case law cited within any court document via Fastcase.

Analytics At Your Fingertips



Learn what happened the last time a particular judge, opposing counsel or company faced cases similar to yours.

Advanced out-of-the-box PTAB and TTAB analytics are always at your fingertips.

API

Docket Alarm offers a powerful API (application programming interface) to developers that want to integrate case filings into their apps.

LAW FIRMS

Build custom dashboards for your attorneys and clients with live data direct from the court.

Automate many repetitive legal tasks like conflict checks, document management, and marketing.

FINANCIAL INSTITUTIONS

Litigation and bankruptcy checks for companies and debtors.

E-DISCOVERY AND LEGAL VENDORS

Sync your system to PACER to automate legal marketing.