

I, Noah Oskow, hereby declare under penalty of perjury that the following statements are made based on personal knowledge and are true and correct:

1. I am fluent in both Japanese and English and have worked as a professional translator since 2012.
2. My education experience includes two years at Sophia University in Tokyo and a BA in East Asian Languages and Cultures: Japanese from the University of Kansas.
3. I am a native English speaker.
4. I have been speaking, reading, and writing Japanese for 16 years.
5. I lived and worked in Japan for over six years.
6. My translation experience has covered a wide variety of topics, including many patent translations.
7. I prepared the attached translation, which is, to the best of my knowledge, a true and correct translation of Japanese Patent JP07280583.

I understand that willful false statements and the like are punishable by fine or imprisonment, or both, under 18 U.S.C. Section 1001.

Date: 10/05/2018



Noah Oskow
Translator

(19) Japanese Patent Office (JP)

(12) Open patent publication
(A)

(11) Patent application publication number
Patent disclosure Heisei7-280583
(43) release date 10/27/1995

(51) Int.Cl. ⁶	Identification symbol	Office reference number	F 1	Technical display place
G01C	21/00	Z		
G08G	1/005			
	1/0969			
//G01S	5/02	Z		
	5/14			

Request for examination Unclaimed
Number of claims 2 FD (All 10 terms)

(21) application number
Japanese patent application6-99360

(22) Filing date 4/13/1994

(71) Applicant 591261509
Ekos Research Co., Ltd.
2-19-12, Sotokanda, Chiyoda-ku, Tokyo

(72) Inventor Seiichi Suzuki
2-19-12, Sotokanda, Chiyoda-ku, Tokyo
In Ekosu Research Inc.

(72) Inventor Toshihiro Mori
2-19-12, Sotokanda, Chiyoda-ku, Tokyo
In Ekosu Research Inc.

(74) An agent patent attorney
Takashi Kawai (other 1)

(54) [Title of the invention] Portable navigation device

(57) [summary]

[purpose] Provided is a portable navigation device which can facilitate direction recognition.

[Constitution] The map drawing unit 28 shows the map drawing data 243, character data 24, etc. of the map information storage unit 24 as a map screen coincident with the actual orientation on display 12 in accordance with the azimuth of the device detected by the orientation centimeter 40.

When the direction of the apparatus coincides with the azimuth of the destination or the recommended route, the guidance information generating section 20 causes speaker 13 to output the guidance sound, and causes display 12 to display an arrow indicating the direction of the destination, etc.

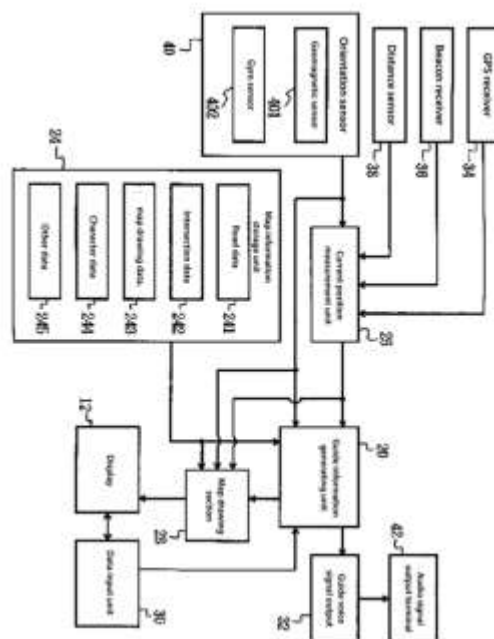

【Range of Claims】

【Claim 1】“Guidance object information storage” refers to that in which at least one of the position information of the destination and the route information to the destination is stored as a guidance object, “current position detection” means for detecting the current position of the apparatus main body, “guidance target azimuth determining” refers to determining an azimuth of the guidance target stored in the guidance object information storage, referring with respect to a current position detected by the main body direction detection, referring to a main body direction detection referring to the means for detecting an azimuth in which the apparatus body faces. From the azimuth of the main apparatus body detected by the main body direction detecting means and the azimuth of the guidance object judged by the guidance target azimuth judging method.

【Claim 2】A map information storage unit that stores map information, a display unit that is fixed to the main apparatus body and that outputs image information, map information stored in the map information storage group, and map rendering methods for rendering on the display method on the basis of the azimuth of the apparatus main body in coincidence with the actual orientation.

【DETAILED DESCRIPTION OF THE INVENTION】

【0001】

【Industrial field of application】The present invention relates to a portable navigation device.

【0002】

【Conventional technology】

The navigation device shows the current position, the direction of the destination, and the route to the destination for a person who is unfamiliar with geography, and in recent years, for those who move about on foot, for whom navigation apparatuses have been developed. The portable navigation device draws a map around the current position, a mark indicating the current position and a route to the destination on display. Also, the guidance of the current position and the guidance of the course direction for going to the destination are outputted in voice format. For example, the map displayed on display is drawn such that the upper side of the display is north. By viewing this map, the carrier (guided person) of the portable navigation device can recognize the direction in which the user actually faces. It makes you recognize the direction to go.

【0003】

【Problem to be solved by invention】In a conventional navigation device for portable use, for example, in a map on a drawn display, even when a building serving as a marker is located diagonally to the right, sometimes it is that it cannot be easily recognized which way is located in the view which you are seeing. In such a case, one has to change the direction it was facing and compare the actual buildings and the circumstances of the surroundings with the buildings, etc. on the map. Another example is possessing a compass and having to match the actual orientation with the orientation on the map as drawn. In this way, it is sometimes difficult for the guided person to recognize the direction of the target and the direction to go in the actual road situation.

【0004】Therefore, an object of the present invention is to provide a portable navigation apparatus which can facilitate direction recognition.

【0005】

【Means for solving the problem】According to a first aspect of the present invention, there is provided a guidance object information storage means in which at least one of position information of a destination and route information to a destination is described as a target of guidance, a current position detection means a guidance target azimuth judging means for judging an azimuth of the guidance object stored in the guidance object information means with respect to the current position detected by the present position detecting means, the main body for detecting an azimuth in which the main body of the apparatus faces an azimuth detecting means, an azimuth of the apparatus body detected by the main body direction detecting means and the azimuth of the guidance target azimuth judging means. According to a second aspect of the present invention, there is provided a portable navigation apparatus comprising: map information storage means for storing map information; display means fixed to the main apparatus body for outputting image information; map information storage means and map rendering means for rendering the on-map information stored in said main body display means coincident with the actual orientation based on the azimuth of said apparatus main body detected by said main body direction detecting means.

【0006】

【Action】

In the portable navigation device according to the first aspect, the guidance target azimuth determining means determines the azimuth of the guidance target stored in the guidance object information storage means with respect to the current position detected by the current position detection means. Then, the guide sound output means outputs the guide sound in accordance with the direction of the main body of the apparatus determined by the main body orientation determining means. In the portable navigation device according to the second aspect of the invention, the map drawing means coincides the map information stored in the map information storage means with the actual orientation based on the azimuth of the main apparatus body detected by the main body-direction detection means and draws on the display means.

【0007】

【Example】 Hereinafter, an embodiment of a portable navigation device of the present invention will be described in detail with reference to FIGS.1 to 12. FIG. 1 shows an appearance of portable navigation device 10 according to this embodiment. The portable navigation device 10 has a weight and a size enough to be able to be placed on the palm of the hand, and the display 12 on which the guide information such as the map around the current location and the guide information is displayed, and a guide sound such as guidance sound or "beeping" are outputted from speaker 13, a power switch, an input key 14 for performing various operations. Guide voice can be output from earphone 16 as well.

【0008】 FIG. 2 shows the configuration of the portable navigation device 10. The portable navigation device 10 includes a map information storage unit 24 in which map information is stored from a guidance information generating unit 20 for generating various guidance information for carriers of the device, a current information processing unit and a position measuring unit 26. Further, the portable navigation device 10 includes a map drawing section 28 for drawing a map, data input section 30 for inputting various data by the input key 14, and guidance sound signal output section 32 for outputting guidance sound. 【0009】 The map information storage unit 24 stores, as map information, road data 241, intersection data 242, map drawing data 243, character data 244, photograph information of characteristic points, and various areas such as hotels, tourist guides, etc. , Information in each area, and other data 245 in which voice data for voice guidance is stored. The map information storage unit 24 supplies each map information to the guidance information generating unit 20 and the map drawing unit 28. As the storage medium of the map information storage unit 24, for example, a CD-ROM

(Read Only Memory), an IC card, or a magneto-optical disk or a magnetic disk is used.

【0010】 Here, the road data 241 includes the thickness of each road, the length of the road, the coordinate position at each point between the starting point and the ending point (longitude, latitude), such as the intersection number at the starting point or ending point of the road, as the data necessary for route guidance. Map drawing data 243 is a data for drawing the river water system, mountain topography, buildings, routes, roads, etc. on display 12, and each data has absolute coordinates specified by longitude and latitude there. The map drawing data 243 is hierarchized for each scale of the map, and the data of the lowest layer is a data for drawing a map which is a scale of 1 / 10,000, including narrow allies, shop names, etc. This includes detailed data.

【0011】 As shown in FIG. 1, character data 244 is used for displaying on the map an abbreviated number of a feature to be a mark showing a department store, a school, or a name of a location and a place name (hereinafter referred to as "place name, etc."). Character data 244 has data of a character string corresponding to each place name, etc. and dictionary data composed of font data of all characters to be displayed on the map. The character string data includes coordinate data indicating the absolute coordinates (latitude and longitude) of the center point of the character string, that is the intersection point of the diagonal line of the rectangle determined by the vertical width and the length of the character string, and coordinate data and code data for specifying the font data (abbreviation is one character). Each character string data is linked with map drawing data 243 by coordinate data.

【0012】 The current position measuring unit 26 continues to the GPS (Global Positioning System) receiver 34, the beacon receiver 36, the distance sensor 38, and the direction sensor 40, respectively. The GPS receiver 34 receives radio waves of GPS satellites, and the current position measuring unit 26 calculates the absolute position of the portable navigation device 20 based on the received data of the GPS receiver 34. On the other hand, the beacon receiver 36 receives position information from a beacon arranged on the road. The azimuth sensor 40 has a geomagnetism sensor 401 for detecting the orientation of the portable navigation device 10 by detecting the geomagnetism, and a gyro sensor 402 such as a gas rate gyroscope or a fiber optic gyroscope for detecting the rotational angular velocity.

【0013】 Here, the two types of sensors are used because the geomagnetic sensor 401 detects the

geomagnetism of the mobile navigation device 10 itself, the structure made of iron, such as a bridge, or the like. This is because the magnetic field is detected and the direction detection may be erroneous in some cases. Accordingly, in the azimuth sensor 40, an azimuth detection is performed using a gyro sensor 402 which is not usually influenced by an external magnetic field, and an error of the detected value is corrected on the basis of a detection value of the geomagnetic sensor 401, whereby accurate azimuth detection.

[0014] The azimuth data detected by the direction sensor 40 is supplied not only to the current position measurement unit 26 but also to the guide information generation unit 20 and the map drawing unit 28. The distance sensor 264 detects the acceleration of the portable navigation device 10, for example, and obtains the moving distance by integrating twice. Although the current position measuring unit 26 can measure the position independently from the GPS receiver 34 and the beacon receiver 36, in a place where it is impossible to receive from a GPS satellite or a beacon, the current position measuring unit 26 measures the distance sensor 264 and the direction sensor. The absolute position is calculated by dead reckoning navigation using 263.

[0015] The map drawing unit 28 includes a drawing CPU (central processing unit) that performs various processes for drawing a map, a recommended route, an arrow indicating the direction of the route direction and the destination, and a map information storage unit. And a drawing data RAM (random access memory) in which various data read from the RAM 24 are stored. The map drawing unit 28 rotates the map around the current position so as to render on display 12 so that the direction on the drawn map coincides with the actual orientation. That is, the coordinate data in the map drawing data 243 and the character data 244 are converted in accordance with the current position measured by the current position measuring section 26 and the azimuth detected by the direction sensor 40, and the map and character after coordinate conversion on display 12. The RAM for the drawing data of the map drawing unit 28 includes storage areas for storing map drawing data 243 after coordinate conversion and drawing data of character data 244 and other drawing data displayed on the map, for example, arrows indicating the current position and a storage area for storing drawing data such as commands.

[0016] FIG. 3 schematically shows a storage area of each drawing data in the drawing data RAM. The storage areas of the respective drawing data are linked to each other by the coordinate data of the respective drawing data 243, 244, etc., and have a layer structure as shown in FIG. 3. That is, the

drawing data RAM has a map layer 50, and a character layer 52 as storage areas in which the map is drawing data 243 and the character data 244 after coordinate conversion are respectively stored. It also has a remaining material first layer 54 for storing drawing data of arrows indicating the position and orientation of the portable navigation device 10 and a command layer 56 for storing various commands drawing data. By overlapping and developing the data of each layer 50, 52, 54, 56 on the bit map memory of the display 12, for example, the screen shown in FIG. 1 is displayed. As the display 12, a liquid crystal display, a plasma display or the like is used.

[0017] The data input unit 30 is for the user to input various destinations (arrival points) and various operation instructions to the portable navigation device 10. In the present embodiment, the data input unit 30 is mainly composed of a plurality of input keys 14 shown in FIG. 1 and a touch panel on which an input operation is performed by touching the display screen of the display 12, but a keyboard, a mouse, a light pen, a joystick, a voice recognition device, may be used. The guidance voice signal output unit 32 synthesizes predetermined voice and guidance tone according to a command from the guidance information generating unit 20 and supplies the signal to the voice output terminal 42. For example, guidance sounds such as "please turn to the right at the next intersection," and guidance sounds such as "beep-beep-beep" are outputted from the speaker 13 or the earphone 16 which are thrown to the sound signal output terminal 42.

[0018] The guidance information generating unit 20 includes a CPU that performs processing for outputting various guidance information to the wearer, a ROM (read-only memory) in which a predetermined program is stored, and input data and the CPU and a navigation RAM for storing processing results. The guidance information generating unit 20 generates navigation information stored in the ROM from the current position measured by the current position measuring unit 26 and the destination input to the data input unit 30 and the road data 241 and the intersection data 242 of the map information storage unit 24. Based on the program, the recommended route to the destination is searched. Also, the direction in which the wearer should travel along the recommended route is determined from the searched route data and the current position measured by the current position measuring unit 26.

[0019] The guidance information generating unit 20 also determines the direction of the destination from the coordinate data of the input destination. Then, by supplying the various kinds of guidance information as the judgment result to the map drawing unit 28 and

Explore Litigation Insights

Docket Alarm provides insights to develop a more informed litigation strategy and the peace of mind of knowing you're on top of things.

Real-Time Litigation Alerts



Keep your litigation team up-to-date with **real-time alerts** and advanced team management tools built for the enterprise, all while greatly reducing PACER spend.

Our comprehensive service means we can handle Federal, State, and Administrative courts across the country.

Advanced Docket Research



With over 230 million records, Docket Alarm's cloud-native docket research platform finds what other services can't. Coverage includes Federal, State, plus PTAB, TTAB, ITC and NLRB decisions, all in one place.

Identify arguments that have been successful in the past with full text, pinpoint searching. Link to case law cited within any court document via Fastcase.

Analytics At Your Fingertips



Learn what happened the last time a particular judge, opposing counsel or company faced cases similar to yours.

Advanced out-of-the-box PTAB and TTAB analytics are always at your fingertips.

API

Docket Alarm offers a powerful API (application programming interface) to developers that want to integrate case filings into their apps.

LAW FIRMS

Build custom dashboards for your attorneys and clients with live data direct from the court.

Automate many repetitive legal tasks like conflict checks, document management, and marketing.

FINANCIAL INSTITUTIONS

Litigation and bankruptcy checks for companies and debtors.

E-DISCOVERY AND LEGAL VENDORS

Sync your system to PACER to automate legal marketing.