

(12) **United States Patent**
Ito et al.

(10) **Patent No.:** **US 6,684,209 B1**
 (45) **Date of Patent:** **Jan. 27, 2004**

(54) **SECURITY METHOD AND SYSTEM FOR STORAGE SUBSYSTEM**

2002/0029319 A1 * 3/2002 Robbins et al. 711/114

(75) Inventors: **Ryusuke Ito**, Odawara (JP); **Yoshinori Okami**, Odawara (JP)

EP 0 881 560 A2 2/1998
 JP 10-333839 12/1998

(73) Assignee: **Hitachi, Ltd.**, Tokyo (JP)

* cited by examiner

(*) Notice: Subject to any disclaimer, the term of this patent is extended or adjusted under 35 U.S.C. 154(b) by 0 days.

Primary Examiner—Kim Vu
Assistant Examiner—Gwen Liang
 (74) *Attorney, Agent, or Firm*—Townsend and Townsend and Crew LLP

(21) Appl. No.: **09/561,404**

(57) **ABSTRACT**

(22) Filed: **Apr. 27, 2000**

According to the present invention, techniques for performing security functions in computer storage subsystems in order to prevent illegal access by the host computers according to logical unit (LU) identity are provided. In representative embodiments management tables can be used to disclose the Logical Unit in the storage subsystem to the host computers in accordance with the users operational needs. In a specific embodiment, accessibility to a storage subsystem resource can be decided when an Inquiry Command is received, providing systems and apparatus wherein there is no further need to repeatedly determine accessibility for subsequent accesses to the Logical Unit. Many such embodiments can maintain relatively high performance, while providing robust security for each LU.

(30) **Foreign Application Priority Data**

Jan. 14, 2000 (JP) 2000-010115

(51) **Int. Cl.**⁷ **G06F 17/30**

(52) **U.S. Cl.** **707/9; 707/10**

(58) **Field of Search** 711/153, 100, 711/152, 5, 114; 345/418; 707/9, 10; 703/23; 713/201

(56) **References Cited**

U.S. PATENT DOCUMENTS

6,260,120 B1 * 7/2001 Blumenau et al. 711/152
 6,295,575 B1 * 9/2001 Blumenau et al. 711/5

38 Claims, 23 Drawing Sheets

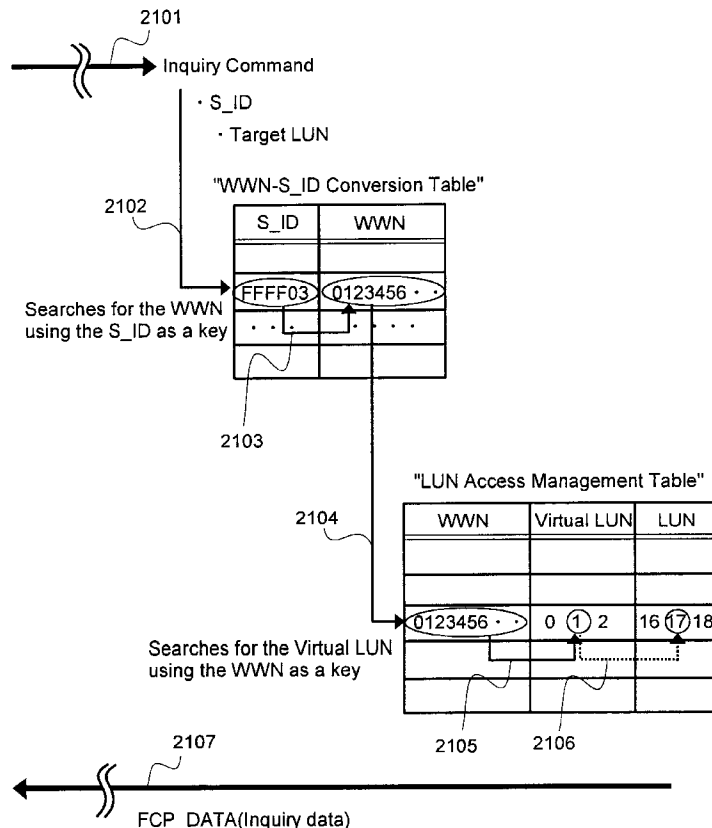

FIG. 1

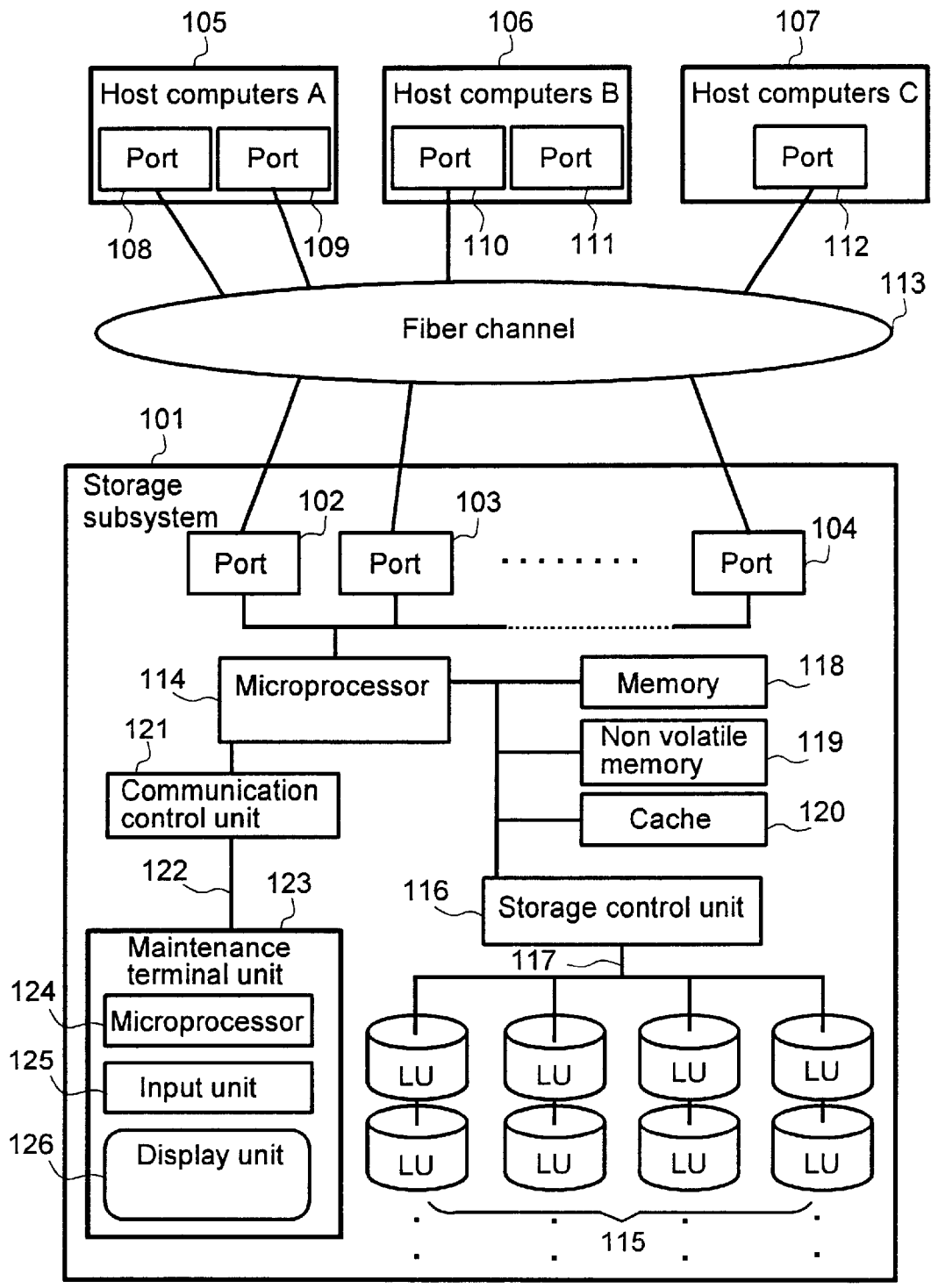

FIG.2

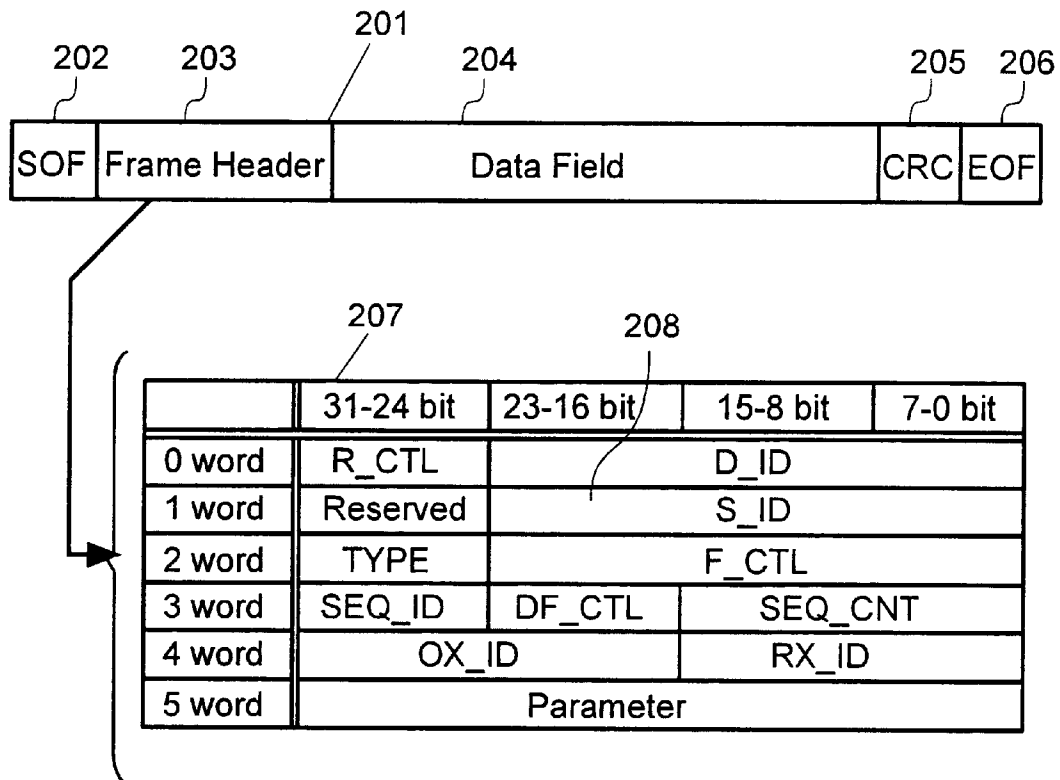

FIG. 3

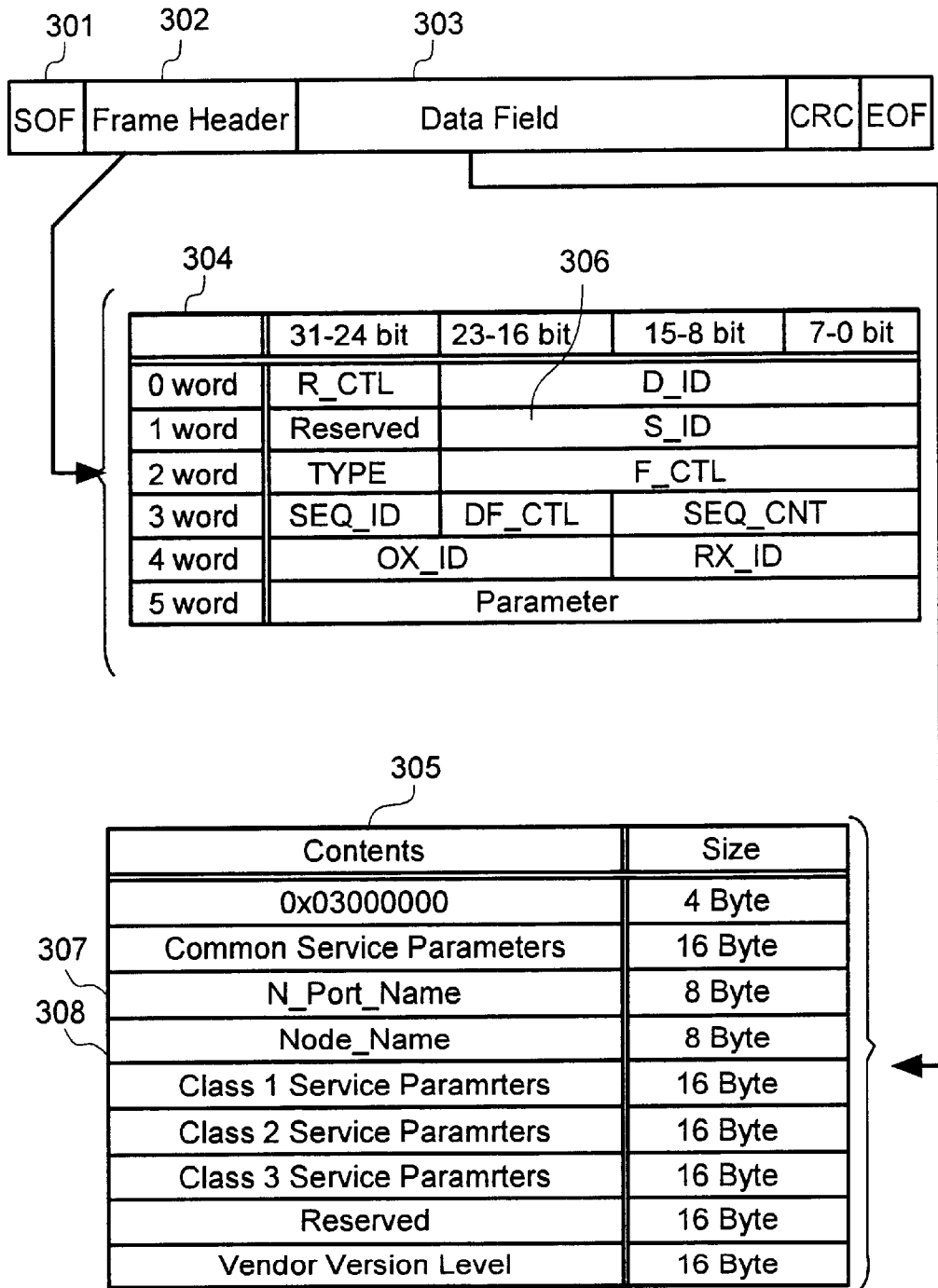
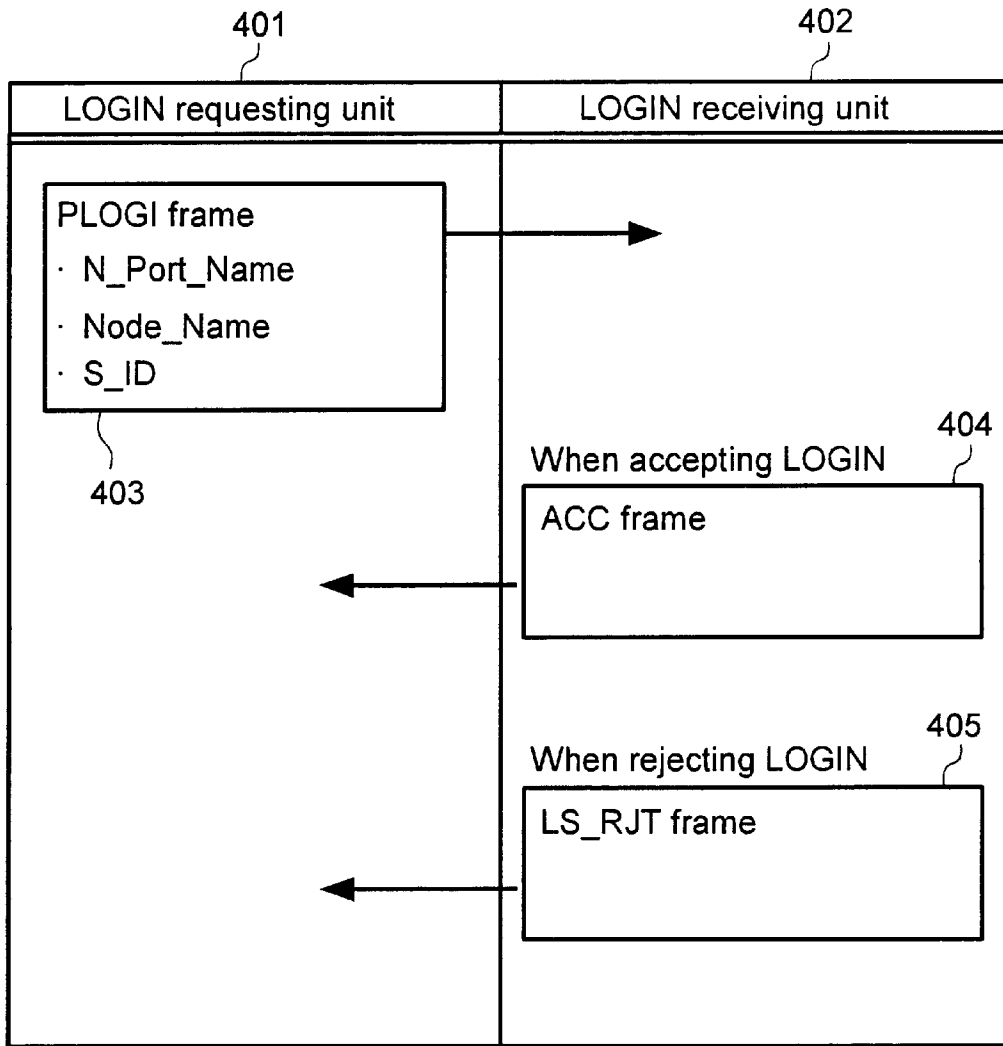

FIG.4



Explore Litigation Insights

Docket Alarm provides insights to develop a more informed litigation strategy and the peace of mind of knowing you're on top of things.

Real-Time Litigation Alerts



Keep your litigation team up-to-date with **real-time alerts** and advanced team management tools built for the enterprise, all while greatly reducing PACER spend.

Our comprehensive service means we can handle Federal, State, and Administrative courts across the country.

Advanced Docket Research



With over 230 million records, Docket Alarm's cloud-native docket research platform finds what other services can't. Coverage includes Federal, State, plus PTAB, TTAB, ITC and NLRB decisions, all in one place.

Identify arguments that have been successful in the past with full text, pinpoint searching. Link to case law cited within any court document via Fastcase.

Analytics At Your Fingertips



Learn what happened the last time a particular judge, opposing counsel or company faced cases similar to yours.

Advanced out-of-the-box PTAB and TTAB analytics are always at your fingertips.

API

Docket Alarm offers a powerful API (application programming interface) to developers that want to integrate case filings into their apps.

LAW FIRMS

Build custom dashboards for your attorneys and clients with live data direct from the court.

Automate many repetitive legal tasks like conflict checks, document management, and marketing.

FINANCIAL INSTITUTIONS

Litigation and bankruptcy checks for companies and debtors.

E-DISCOVERY AND LEGAL VENDORS

Sync your system to PACER to automate legal marketing.