

Dec. 2, 1969

E. A. JOHNSON

3,482,241

TOUCH DISPLAYS

Filed Aug. 2, 1966

3 Sheets-Sheet 1

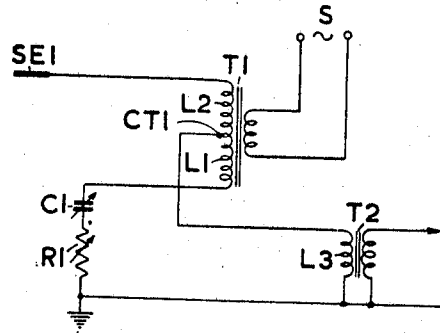

FIG. 1

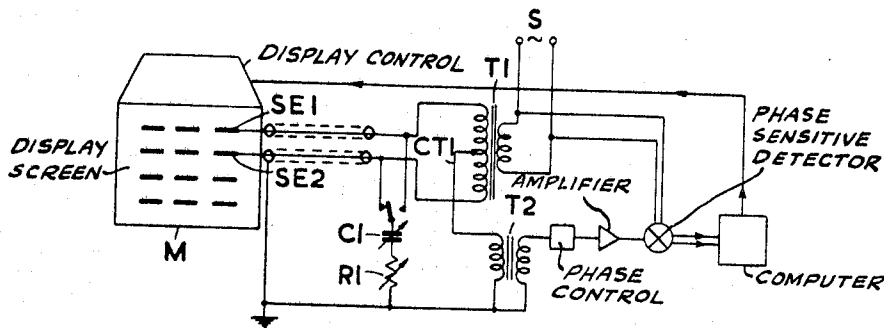

FIG. 2

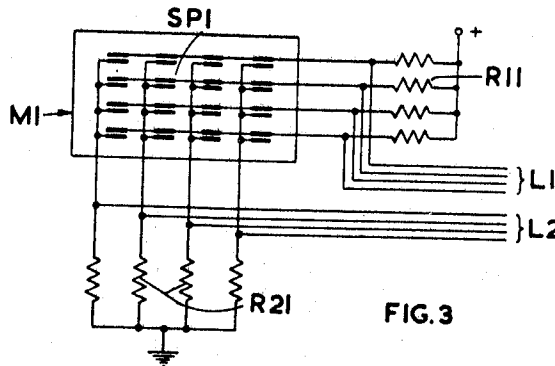

FIG. 3

Inventor
ERIC ARTHUR JOHNSON
By
Cushman, Haly & Cushman
Attorneys

Dec. 2, 1969

E. A. JOHNSON

3,482,241

TOUCH DISPLAYS

Filed Aug. 2, 1966

3 Sheets-Sheet 2

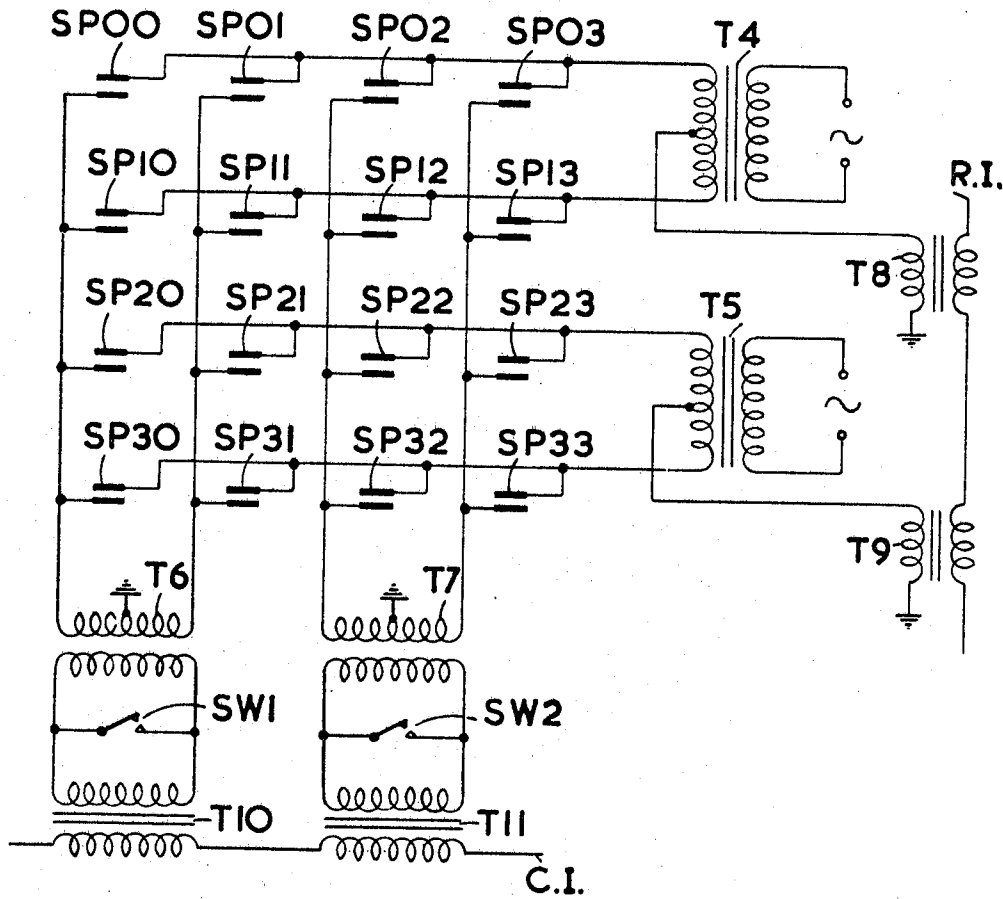

FIG. 4

Inventor
ERIC ARTHUR JOHNSON
By
Cushman, Hurley & Cushman
Attorneys

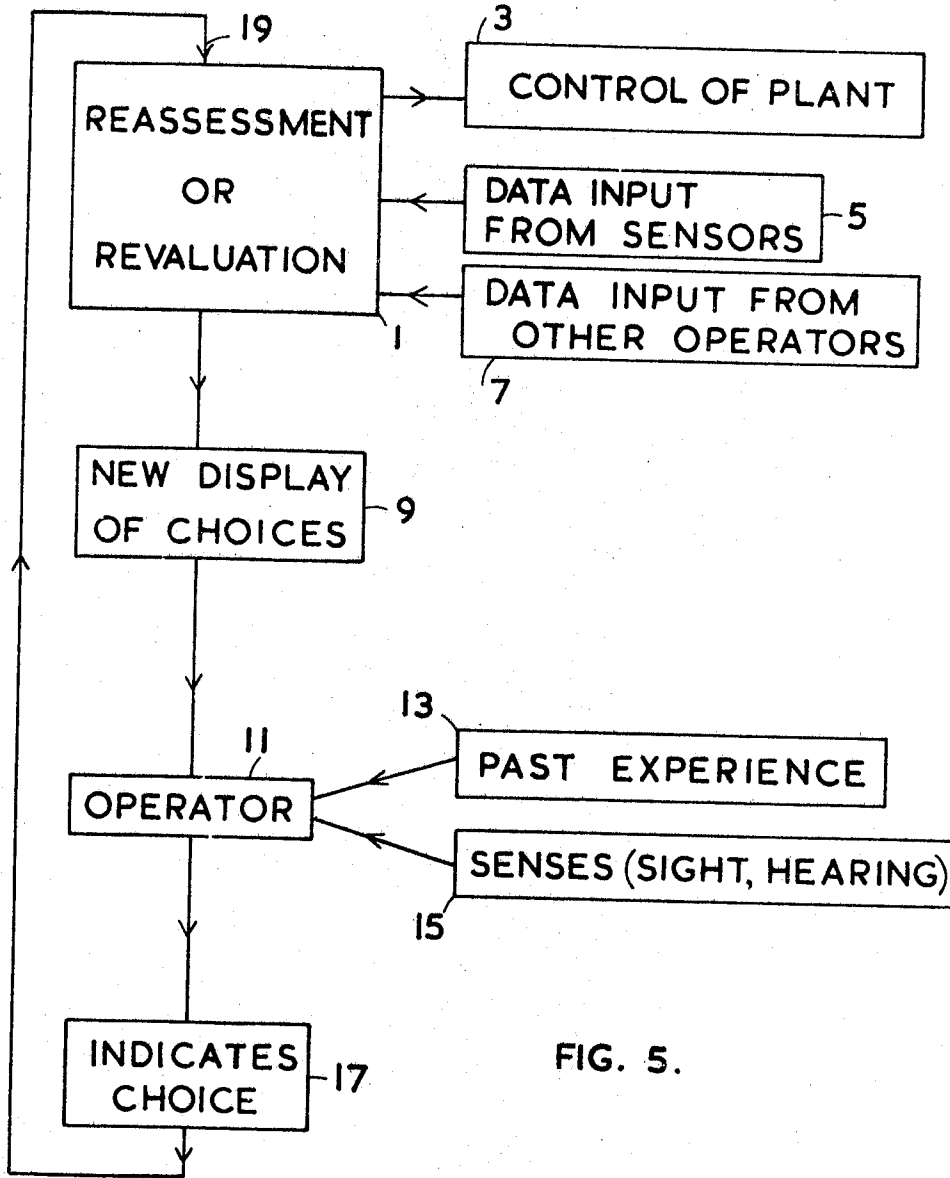

FIG. 5.

Inventor
ERIC ARTHUR JOHNSON
By
Cushman, Stuby & Cushman
Attorneys

1

2

3,482,241

TOUCH DISPLAYS

Eric Arthur Johnson, Malvern, England, assignor to
Minister of Aviation in Her Britannic Majesty's
Government of the United Kingdom of Great
Britain and Northern Ireland, London, England

Filed Aug. 2, 1966, Ser. No. 569,731

Claims priority, application Great Britain, Aug. 5, 1965,
33,524/65; June 28, 1966, 28,883/66

Int. Cl. G09b 13/00; H05b 41/00; G06k 1/00

U.S. Cl. 340-337

7 Claims

ABSTRACT OF THE DISCLOSURE

A plurality of touch-sensitive contacts, placed adjacent the screen of a cathode ray tube, which may be selectively actuated for indicating which portion of the image on the cathode ray screen is to be examined in further detail. The position of the actuated contact with respect to the viewing screen indicates which portion of the image has been selected to an output means such as a data processing system. Either resistance change or capacitance change across the actuated contact may be sensed.

The presnet invention relates to touch displays.

A very large number of so-called automatic data processing systems require the co-operation of human operators to achieve satisfactory operation. In many of these systems it is necessary to reduce operator reaction time to a minimum, which in turn demands an arrangement where communciations between the operator and the system and vice versa is the best possible. This requires that the methods of presenting information to and receiving instructions from the operator should be rapid and easy.

For the presentation of information to the operator, a method often used at the present time is some form of printing, usually electromechanical. Although the normal teleprinter output is rather slow in relation to the speed with which an operator can absorb information, an extension of the technique to line printing can overcome this. Alternatively an electronic data display is sometimes used, and in the case of line printing or electronic data display time required to produce a readable output from the system does not really add significantly to the time required for an operator to accept information. There is also a considerable amount of flexibility of format available to ease understanding.

The situation is not so satisfactory in the case of accepting instructions from an operator. A current method is to make use of some form of keyboard with either a standard set of alpha-numeric keys or some special keys, usually called function keys, or both. The function keys as their name implies, usually provide control instructions to the system whilst the alpha-numeric keyboard is used for information input, interpreted by the system in accordance with the most recent control instructions. The process can be rather slow and clumsy especially when a fairly large system is involved with several operators having a wide range of input possibilities in the interests of flexibility.

It is an object of the invention to provide means for feeding data (instructions or information) to a system by using a touch display by means of which means responsive to touch are associated with a display. The means responsive to touch may be connected to a data input of the system.

According to the present invention there is provided, for use with means for displaying data, means responsive

The means responsive to touch may include a transparent screen responsive to touch suitable for fixing in front of the means for displaying data.

Preferably the means responsive to touch is connected to a data input of a data processing system. In such a case it is highly advantageous for the means for displaying data to be connected to a data output of the data processing system in such a manner that the data displayed may be altered under the control of the data processing system.

A convenient means for displaying data is, of course, provided by the cathode ray tube, which may be controlled to write output information on its screen; the invention provides a method of feeding more information to the data processing system, so continuing the programme. For example, the cathode ray tube may display a list of items and it may be desired to examine one of the items in further detail. It is frequently troublesome to indicate to the data processing system which item is the one to be examined. Under these circumstances it should be possible to provide sites on the cathode ray tube which are responsive to touching by the hand of the operator. The effect would be that the operator touches the place on the cathode ray tube screen where the item is displayed and this signals back to the data processing system that that particular item is selected (for further examination, say).

Such a system may be arranged by embedding electric wires in the screen, one to each site on the cathode ray tube, and using the operator's natural capacitance to earth, which is of the order of 100 pf.

In an alternative arrangement a pair of wires may be arranged close to one another and the operator's finger, touching the two wires, would short them out via the natural skin resistance of the finger plus the contact resistance, which is of the order of 500,000 ohms.

Embodiments of the invention will be described by way of example with reference to the accompanying drawings, in which:

FIGURE 1 is a circuit diagram of a touch sensitive system;

FIGURE 2 is a more complete circuit diagram of part of a display incorporating a touch-sensitive system;

FIGURE 3 is a circuit diagram of part of an alternative display incorporating a touch sensitive system;

FIGURE 4 is a circuit diagram of part of a further alternative display incorporating a touch sensitive system; and

FIGURE 5 is a diagrammatic representation of the logic steps taken in a process using a data processing system and input and output facilities.

In FIGURE 1 the primary winding of a transformer T1 is fed from a high frequency source S (say 3000 cycles per second) and the secondary winding is centre-tapped. One half L1 of the secondary winding is connected between the centre tap CT1 and a terminal connected to earth via a variable capacitor C1 and a variable resistor R1 in series and the other half L2 of the secondary winding is connected between the centre tap CT1 and a sensitive electrode SE1. The centre tap CT1 is connected to earth via the primary winding L3 of a transformer T2.

The action of the circuit is as follows. The windings L1 and L2, together with the capacitor C1 and the resistor R1, and the self capacity of the sensitive electrode SE1 form a bridge circuit which is adjusted to be balanced at the frequency f_0 of the source S. When the sensitive electrode SE1 is touched by an operator the capacitance to earth presented to it is sufficient to throw the bridge off balance and an alternating poten-

In FIGURE 2 an electronic data display includes a matrix M of sensitive electrodes SE1, SE2, . . . , two of which are connected (via screened cable) to the end terminals of the transformer T1. One of the end terminals (depending on the stray capacities) of the secondary winding of the transformer T1 is connected to earth via the capacitor C1 and the resistor R1 in series. The centre tap CT1 of the secondary winding of the transformer T1 is connected to earth via the primary winding of the pulse transformer T2, as before. The secondary winding of the transformer T2 is connected to a phase control unit P the output of which is connected to a phase sensitive detector PSD via an amplifier/limiter. The output of the phase sensitive detector PSD is applied to a computer K which has an output applied to the display control DC.

The action of this circuit differs from that of the circuit described with reference to FIGURE 1 in the fact that the bridge circuit R1-C1-T1 secondary-T2 primary may be unbalanced by touching either of the sensitive electrodes SE1 or SE2. In each case the result will be an output from the transformer T2 but the phase relationship of this output with the supply current S will be different for the two different electrodes SE1 and SE2. The function of the phase control P is to ensure that the signal is in the correct phase to ensure a suitable output from the phase sensitive detector after allowing for stray phase shift throughout the system. The output of the transformer T2 is applied from the phase control P to the amplifier A and thence to the phase sensitive detector PSD where its phase is compared with that of the supply current S. The phase sensitive detector PSD has two outputs and these will therefore correspond separately to the two separate sensitive electrodes SE1 and SE2.

Thus an output, indicating which sensitive electrode is touched, is applied to the computer K, where it is used typically to set up a fresh display via the display control DC.

The remaining electrodes (SE3, etc.) are also connected in pairs to circuits similar to FIGURE 2 while for the sake of economy the amplifier A and phase sensitive detector may be time shared between the circuits.

FIGURE 3 is a circuit diagram of part of an alternative display incorporating a touch-sensitive system. In this display a matrix M1 of pairs of sensitive electrodes such as SP1 is arranged on the display. All the upper electrodes of each row are connected together to a positive voltage source via a common resistor such as R11 and all the lower electrodes of each column are connected together to earth via a common resistor such as R21. The terminals remote from the positive voltage source of the resistors (such as R11) associated with the upper electrodes are connected to separate leads in a bundle L1 and the terminals remote from earth of the resistors (such as R21) associated with the lower electrodes are connected to separate leads in a bundle L2.

When a pair of electrodes (such as the pair SP1) is touched by an operator a current will flow and this may be detected both by a voltage drop at the terminal remote from the positive voltage source of the corresponding resistor (such as R11) connected to the positive voltage source and a voltage rise at the terminal remote from earth of the corresponding resistor (such as R21) connected to earth. This rise and fall in voltage may be amplified, inverted and/or otherwise manipulated in a known manner and a series of known gates connected between pairs of wires of which one is from the bundle L1 and one from the bundle L2. By this way which pair of wires has been touched may be determined exactly.

Alternatively the rows of upper electrodes and the columns of lower electrodes may be connected to independent systems each system being a set of circuits similar

FIGURE 4 is a circuit diagram of part of a further alternative display incorporating a touch sensitive system. This is an alternative way of using the skin resistance of the operator's finger to unbalance bridge circuits.

A matrix of pairs of sensitive electrodes SP00, SP01, SP02, SP03, SP10, SP11, SP12, SP13, SP20, SP21, SP22, SP23, SP30, SP31, SP32 and P33 is connected in rows to the secondary windings of two transformers T4 and T5 in the following manner. One terminal of the secondary winding of the transformer T4 is connected to the upper electrode of each of the pairs P00, SP01, SP02 and SP03 of sensitive electrodes in the first row, the other terminal of the secondary winding of the transformer T4 is connected to the upper electrode of each of the pairs SP10, SP11, SP12 and SP13 of sensitive electrodes in the second row, one terminal of the secondary winding of the transformer T5 is connected to the upper electrode of each of the pairs SP20, SP21, SP22 and SP23 of sensitive electrodes in the third row, and the other terminal of the secondary winding of the transformer T5 is connected to the upper electrode of each of the pairs SP30, SP31, SP32 and SP33 of sensitive electrodes in the fourth row.

Similarly the matrix is connected in columns to the primary windings of two transformers T6 and T7 in the following manner. The lower electrode of each of the pairs SP00, SP10, SP20 and SP30 of sensitive electrodes in the first column is connected to one terminal of the primary winding of the transformer T6, the lower electrode of each of the pairs SP01, SP11, SP21 and SP31 of sensitive electrodes in the second column is connected to the other terminal of the primary winding of the transformer T6, the lower electrode of each of the pairs SP02, SP12, SP22 and SP32 of sensitive electrodes in the third column is connected to one terminal of the primary winding of the transformer T7 and the lower electrode of each of the pairs SP03, SP13, SP23 and SP33 of sensitive electrodes in the fourth column is connected to the other terminal of the primary winding of the transformer T7.

The primary windings of the transformers T4 and T5 are each excited by a high frequency source (say 3000 cycles per second). The primary winding of a transformer T8 is connected between a centre tap on the secondary winding of the transformer T4 and earth and the primary winding of a transformer T9 is connected between a centre tap on the secondary winding of the transformer T5 and earth. The secondary windings of the transformers T8 and T9 are connected in series in a row interrogate wire RI.

The primary windings of the transformers T6 and T7 are each earth centre tapped. The secondary winding of the transformer T6 is connected across the primary winding of a transformer T10 and a switch SW1 is connected across them both. The secondary winding of the transformer T7 is connected across the primary winding of a transformer T11 and a switch SW2 is connected across them both. The secondary windings of the transformers T10 and T11 are connected in series in a column interrogate wire CI.

The action of the circuit is an extension of that described above with reference to FIGURE 2; the touching of a pair of electrodes such as the pair SP12 will unbalance two bridge circuits, namely in this case the bridge circuit which includes the secondary winding of the transformer T4 and the bridge circuit which includes the primary winding of the transformer T7, the bridge circuits associated with the columns (i.e. the bridge circuits which include the primary windings of the transformers T6 and T7 respectively) being energised from the transformers T4 and T5 via the capacitances between the electrodes of the sensitive electrode pairs SP00 etc. The particular "row" and "column" bridges unbalanced and the direc-

Explore Litigation Insights

Docket Alarm provides insights to develop a more informed litigation strategy and the peace of mind of knowing you're on top of things.

Real-Time Litigation Alerts



Keep your litigation team up-to-date with **real-time alerts** and advanced team management tools built for the enterprise, all while greatly reducing PACER spend.

Our comprehensive service means we can handle Federal, State, and Administrative courts across the country.

Advanced Docket Research



With over 230 million records, Docket Alarm's cloud-native docket research platform finds what other services can't. Coverage includes Federal, State, plus PTAB, TTAB, ITC and NLRB decisions, all in one place.

Identify arguments that have been successful in the past with full text, pinpoint searching. Link to case law cited within any court document via Fastcase.

Analytics At Your Fingertips



Learn what happened the last time a particular judge, opposing counsel or company faced cases similar to yours.

Advanced out-of-the-box PTAB and TTAB analytics are always at your fingertips.

API

Docket Alarm offers a powerful API (application programming interface) to developers that want to integrate case filings into their apps.

LAW FIRMS

Build custom dashboards for your attorneys and clients with live data direct from the court.

Automate many repetitive legal tasks like conflict checks, document management, and marketing.

FINANCIAL INSTITUTIONS

Litigation and bankruptcy checks for companies and debtors.

E-DISCOVERY AND LEGAL VENDORS

Sync your system to PACER to automate legal marketing.