



US006940308B2

(12) **United States Patent**  
**Wong**

(10) **Patent No.:** **US 6,940,308 B2**  
(45) **Date of Patent:** **\*Sep. 6, 2005**

(54) **INTERCONNECTION NETWORK FOR A FIELD PROGRAMMABLE GATE ARRAY**

(75) Inventor: **Dale Wong**, San Francisco, CA (US)

(73) Assignee: **Leopard Logic Inc.**, Cupertino, CA (US)

(\*) Notice: Subject to any disclaimer, the term of this patent is extended or adjusted under 35 U.S.C. 154(b) by 0 days.

This patent is subject to a terminal disclaimer.

(21) Appl. No.: **10/764,216**

(22) Filed: **Jan. 23, 2004**

(65) **Prior Publication Data**

US 2004/0150422 A1 Aug. 5, 2004

**Related U.S. Application Data**

(63) Continuation of application No. 09/923,294, filed on Aug. 3, 2001, now Pat. No. 6,693,456.

(60) Provisional application No. 60/223,047, filed on Aug. 4, 2000.

(51) **Int. Cl.**<sup>7</sup> ..... **H03K 19/173**; G06F 7/38

(52) **U.S. Cl.** ..... **326/41**; 326/38; 710/317

(58) **Field of Search** ..... 326/38, 39, 40, 326/41, 47; 710/317

(56) **References Cited**

**U.S. PATENT DOCUMENTS**

5,299,317 A 3/1994 Chen et al. .... 395/325

5,349,248 A	9/1994	Parlour et al. ....	307/465
5,519,629 A	5/1996	Snider .....	364/490
5,530,813 A	6/1996	Paulsen et al. ....	395/312
5,987,028 A	11/1999	Yang et al. ....	370/380
6,693,456 B2	2/2004	Wong .....	326/41

**FOREIGN PATENT DOCUMENTS**

EP	0919938	6/1999	.....	G06F/17/50
JP	03098353	4/1991	.....	H04L/12/48

**OTHER PUBLICATIONS**

Chan et al., "Architectural Tradeoffs in Field-Programmable-Device Based Computing Systems," GPGAS for Custom Computing Machines, Proceedings, IEEE Workshop on Napa, CA, USA, Apr. 5-7, 1993, pp. 152-161.

*Primary Examiner*—Daniel Chang  
(74) *Attorney, Agent, or Firm*—Aka Chan LLP

(57) **ABSTRACT**

An interconnection network architecture which provides an interconnection network which is especially useful for FPGAs is described. Based upon Benes networks, the resulting network interconnect is rearrangeable so that routing between logic cell terminals is guaranteed. Upper limits on time delays for the network interconnect are defined and pipelining for high speed operation is easily implemented. The described network interconnect offers flexibility so that many design options are presented to best suit the desired application.

**5 Claims, 13 Drawing Sheets**

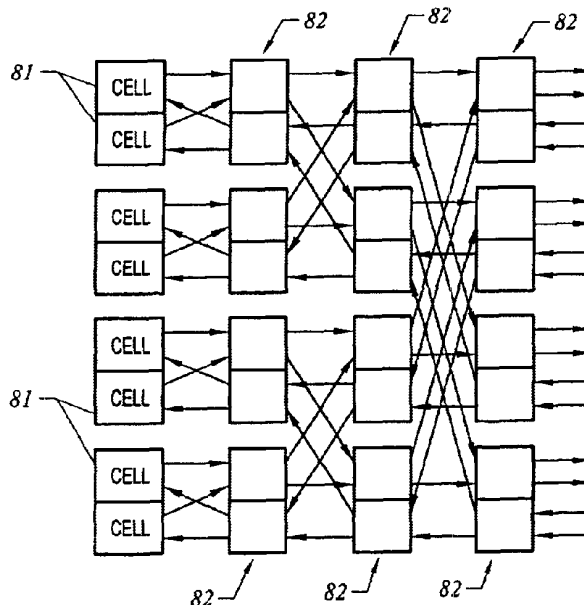

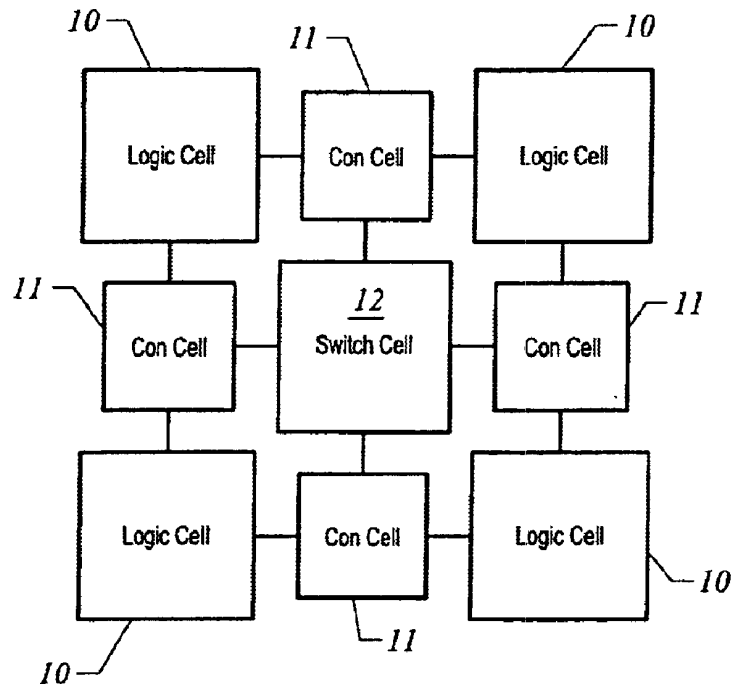

FIG. 1  
(Prior Art)

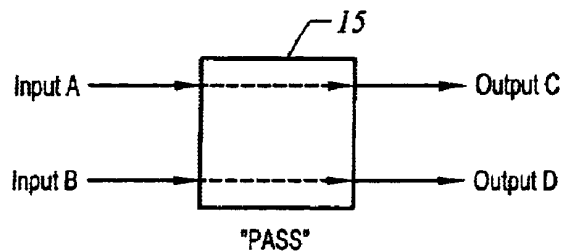

FIG. 2A

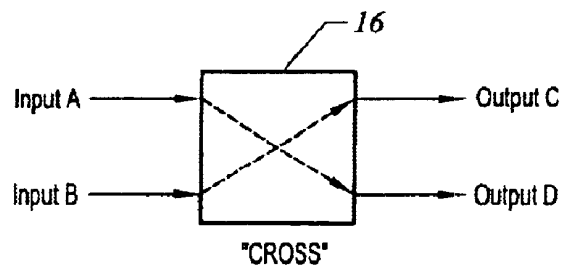

FIG. 2B

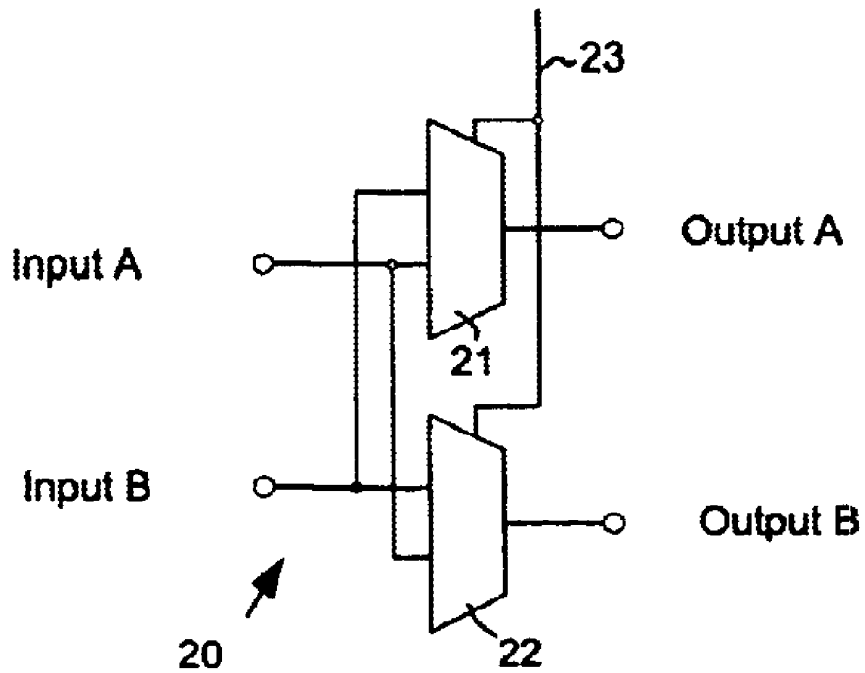

FIG. 2C

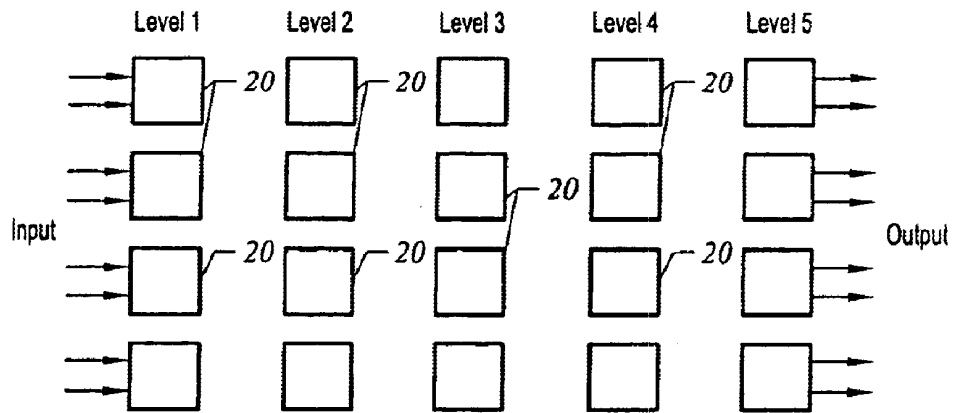

FIG. 3A

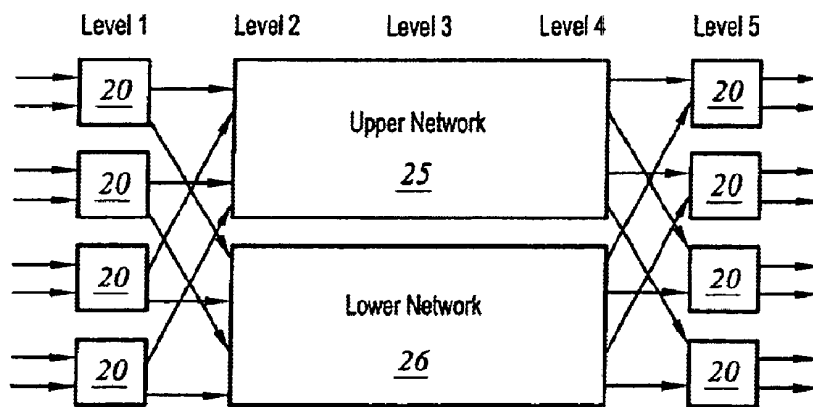

FIG. 3B

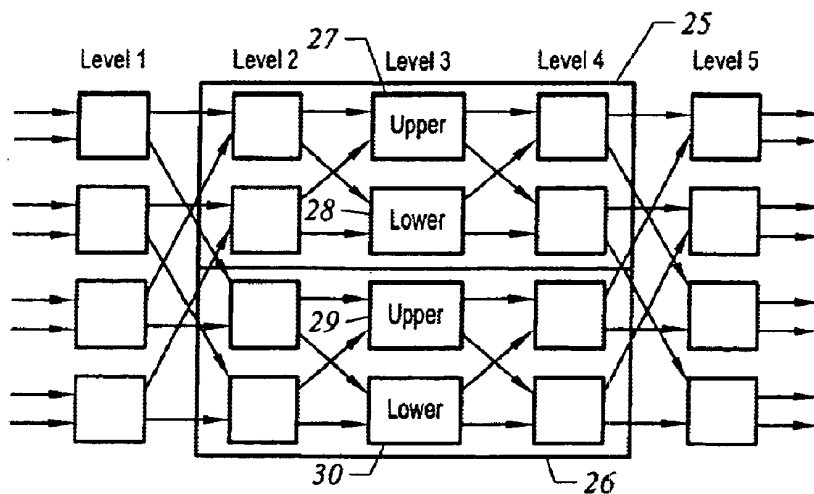

FIG. 3C

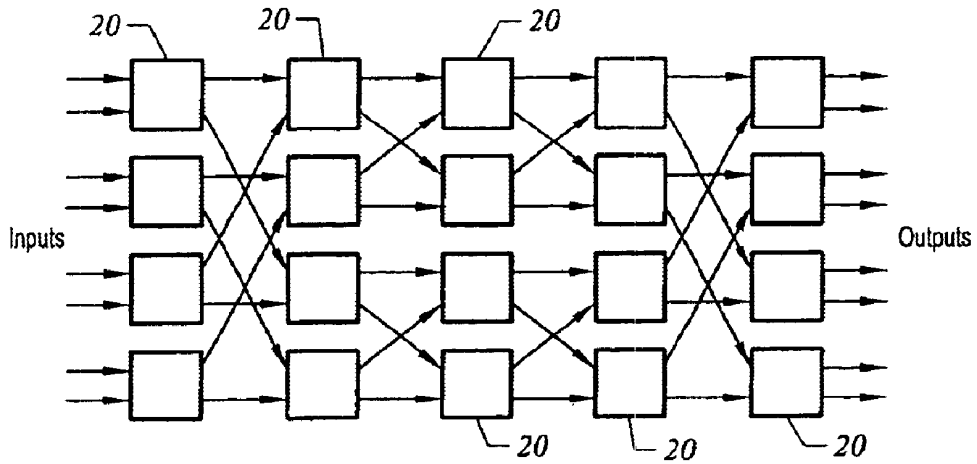

FIG. 3D

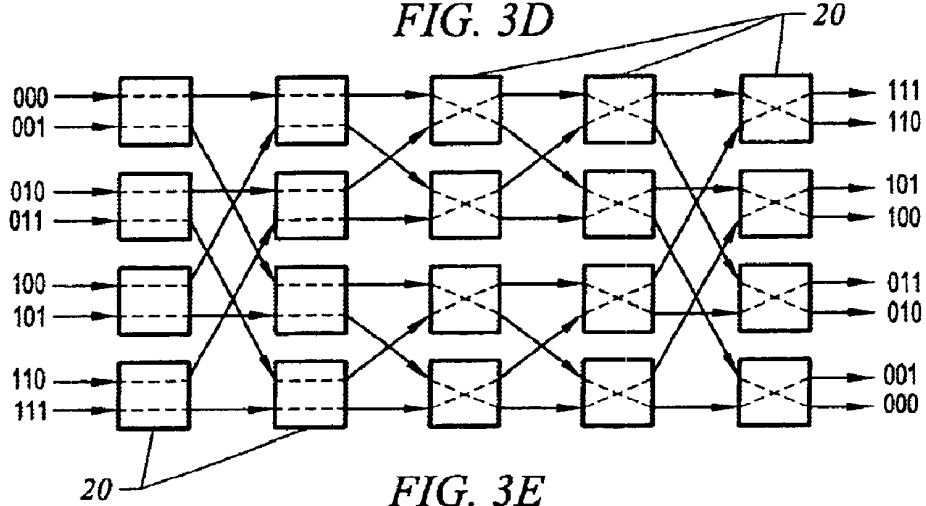

FIG. 3E

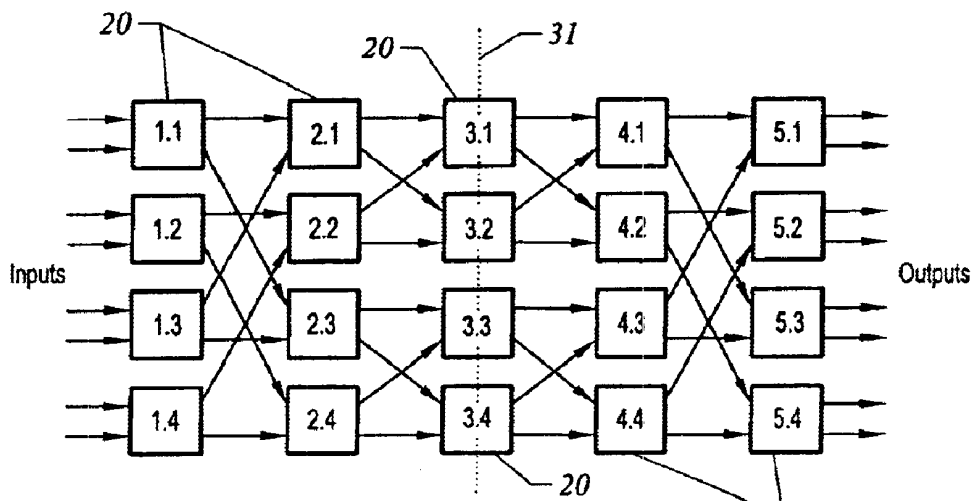

FIG. 4A

# Explore Litigation Insights

Docket Alarm provides insights to develop a more informed litigation strategy and the peace of mind of knowing you're on top of things.

## Real-Time Litigation Alerts



Keep your litigation team up-to-date with **real-time alerts** and advanced team management tools built for the enterprise, all while greatly reducing PACER spend.

Our comprehensive service means we can handle Federal, State, and Administrative courts across the country.

## Advanced Docket Research



With over 230 million records, Docket Alarm's cloud-native docket research platform finds what other services can't. Coverage includes Federal, State, plus PTAB, TTAB, ITC and NLRB decisions, all in one place.

Identify arguments that have been successful in the past with full text, pinpoint searching. Link to case law cited within any court document via Fastcase.

## Analytics At Your Fingertips



Learn what happened the last time a particular judge, opposing counsel or company faced cases similar to yours.

Advanced out-of-the-box PTAB and TTAB analytics are always at your fingertips.

## API

Docket Alarm offers a powerful API (application programming interface) to developers that want to integrate case filings into their apps.

## LAW FIRMS

Build custom dashboards for your attorneys and clients with live data direct from the court.

Automate many repetitive legal tasks like conflict checks, document management, and marketing.

## FINANCIAL INSTITUTIONS

Litigation and bankruptcy checks for companies and debtors.

## E-DISCOVERY AND LEGAL VENDORS

Sync your system to PACER to automate legal marketing.