

**Volume I**  
**Technical and Management Proposal**

**Title:** Energy-Efficient Butterfly FPGA Hardware and Programming Tools

A proposal submitted to  
**Dr. William Harrod, DARPA/TCTO**  
in response to

**DARPA-BAA 10-78:** Omnipresent High Performance Computing (OHPC)

**Technical Area:** Energy Efficient Computing

**Lead Organization:** University of California, Los Angeles (UCLA)  
Department of Electrical Engineering  
Los Angeles, CA 90095-1594

**Type of Business:** Other Educational

**Team Members:** Dejan Markovic (PI)  
Venkat Konda (Consultant)

**Technical Point of Contact:**

Dr. Dejan Markovic, PI  
UCLA Associate Professor  
Electrical Engineering Department  
56-147D Engineering IV Building  
420 Westwood Plaza  
Los Angeles, CA 90095-1594

Tel: (310) 825-8656  
Fax: (310) 206-8495  
Email: [dejan@ee.ucla.edu](mailto:dejan@ee.ucla.edu)

**Administrative Point of Contact:**

Ms. Julia Zhu  
UCLA Senior Grant Analyst  
Office of Contract and Grant Administration  
11000 Kinross Ave, Suite 102  
Los Angeles, CA 90095-1406

Tel: (310) 794-0155  
Fax: (310) 943-1658  
Email: [ocga5@research.ucla.edu](mailto:ocga5@research.ucla.edu)

**Total funds requested:** \$2,374,111  
**Year 1:** \$789,927  
**Year 2:** \$792,100  
**Year 3:** \$792,086

**UCLA**

**Date of proposal:** August 4, 2010



**Table of Contents**

Executive Summary	3
Section II – Technical Details	5
2.1. PowerPoint Summary Chart	5
2.2. Innovative Claims for the Proposed Research	6
Problem Description	6
Research Goals	6
Expected Impact	7
2.3. Proposal Roadmap	8
2.4. Technical Approach	10
2.4.1. Network Architecture and Routing Tools	14
2.4.2. Hardware Design	15
2.4.3. Hardware Mapping	19
Demonstrations and Technology Transition	22
2.5. Statement of Work	24
2.6. Intellectual Property	26
2.7. Management Plan	28
2.8. Schedule and Milestones	30
2.8.1. Schedule Graphic	30
2.8.2. Detailed Task Description	31
2.8.3. Project Management and Interaction Plan	33
2.9. Personnel, Qualifications, and Commitments	34
2.10. Organizational Conflict of Interest Affirmations and Disclosure	36
2.11. Human Use	39
2.12. Animal Use	38
2.13. Statement of Unique Capability Provided by Government or Government-Funded Team Member	39
2.14. Government or Government-funded Team Member Eligibility	40
2.15. Facilities	41
References	42
BEEcube Support Letter	43

### **Executive Summary**

UCLA offers to perform research on a revolutionary new FPGA technology consisting of FPGA hardware and supporting mapping tools. We will design, fabricate, and test hierarchical FPGA interconnect network to demonstrate FPGA technology that is 15x more energy-efficient than existing FPGAs. The new interconnect architecture allows for significant reduction in the number of switch points, buffers, and wire length in comparison to standard 2D-mesh architecture used by existing FPGAs. The proposed technology is a radical departure from 2D-mesh design, which for N logic blocks has complexity  $O(N^2)$ , incomplete and heuristic routing. The proposed technology has only  $O(N \cdot \log_2 N)$  complexity, complete and fully deterministic routing. The proposed technology has significant benefits: 15x lower power, 3x lower area, 2x higher performance compared to existing FPGA technology. The new FPGA technology will be used to demonstrate HPC benchmarks with a 15x higher power efficiency for DOD and commercial users. The PI has established interactions with industrial partners that will lead to the transition of ideas into the commercial space.

# Energy-Efficient Butterfly FPGA Hardware and Programming Tools

## Technical Challenge and Objective

- **Problem:** Presently, FPGA chips use 2D-mesh architecture, which is very complex (over 75% of chip area is interconnect). Interconnect results in **energy-inefficient computations!**

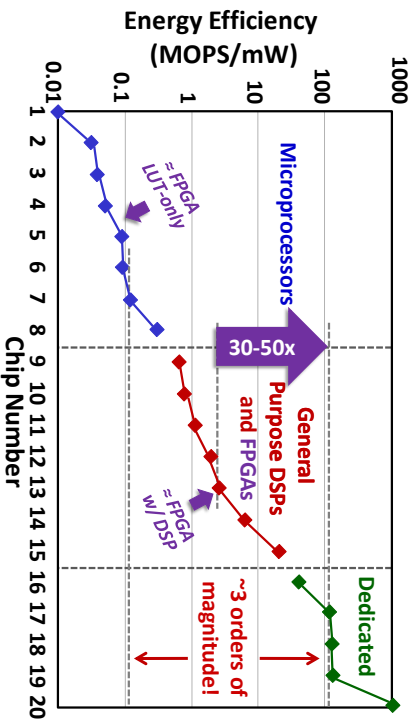

- **Objective:** significantly improve energy efficiency of FPGAs.

## Expected Impact

- New FPGA hardware and mapping tools.
- With significant improvements:
  - Power (15x)
  - Area (3x)
  - Performance (2x)
- To demonstrate HPC benchmarks with **15x higher power efficiency.**
- For DOD and commercial apps.

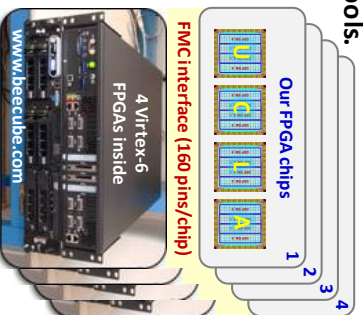

## Key Innovations

- Our hierarchical butterfly interconnect scheme significantly reduces interconnect complexity.

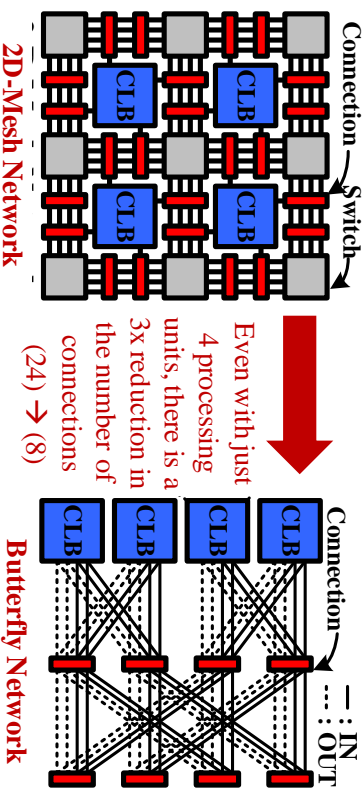

Number of connections in 2D-Mesh and Hierarchical networks

Number of LUTs	2D-Mesh	Hierarchical	Savings factor
N = 1 k	1 M	9,97 k	100x
N = 100 k	10 B	1.66 M	6,200x

- Ideas verified on chip (**3x reduction in interconnect area**).



- Key proposed innovations:
  - Interconnect architecture optimization.
  - Hardware demonstrations of area, power, and performance.
  - Mapping tools for the new FPGA architecture.
  - Demonstrations of HPC benchmarks.

PI: Dejan Markovic (UCLA)

## Section II - Technical Details

### 2.1. PowerPoint Summary Chart

# Explore Litigation Insights

Docket Alarm provides insights to develop a more informed litigation strategy and the peace of mind of knowing you're on top of things.

## Real-Time Litigation Alerts



Keep your litigation team up-to-date with **real-time alerts** and advanced team management tools built for the enterprise, all while greatly reducing PACER spend.

Our comprehensive service means we can handle Federal, State, and Administrative courts across the country.

## Advanced Docket Research



With over 230 million records, Docket Alarm's cloud-native docket research platform finds what other services can't. Coverage includes Federal, State, plus PTAB, TTAB, ITC and NLRB decisions, all in one place.

Identify arguments that have been successful in the past with full text, pinpoint searching. Link to case law cited within any court document via Fastcase.

## Analytics At Your Fingertips



Learn what happened the last time a particular judge, opposing counsel or company faced cases similar to yours.

Advanced out-of-the-box PTAB and TTAB analytics are always at your fingertips.

## API

Docket Alarm offers a powerful API (application programming interface) to developers that want to integrate case filings into their apps.

## LAW FIRMS

Build custom dashboards for your attorneys and clients with live data direct from the court.

Automate many repetitive legal tasks like conflict checks, document management, and marketing.

## FINANCIAL INSTITUTIONS

Litigation and bankruptcy checks for companies and debtors.

## E-DISCOVERY AND LEGAL VENDORS

Sync your system to PACER to automate legal marketing.