



[54] METHOD FOR OPTIMIZING TRACK ASSIGNMENT IN A GRID-BASED CHANNEL ROUTER

[75] Inventors: Yang Cai, San Jose; Michael Chin-Hsen Lin, Fremont, both of Calif.

[73] Assignee: Avant! Corporation, Fremont, Calif.

[21] Appl. No.: 614,129

[22] Filed: Mar. 12, 1996

[51] Int. Cl.⁶ G06F 17/00; G06F 15/50

[52] U.S. Cl. 364/490; 364/488; 364/489; 364/491

[58] Field of Search 364/488-491

[56] References Cited

U.S. PATENT DOCUMENTS

4,615,011	9/1986	Linsker	364/491
5,272,645	12/1993	Kawakami et al.	364/491
5,375,069	12/1994	Sato et al.	364/490

OTHER PUBLICATIONS

Tong Gao & L. Liu. "Minimum Crosstalk Channel Routing". Jul. 11, 1993. Urbana, IL.

Peter M. Maurer. "Automatic Routing of Integrated Circuit Connections: A Tutorial". Apr. 15, 1990. Tampa, FL.

C.-L. Tse and W. Kinsner. "A graph-based heuristic channel router." Sep. 1988. Amsterdam, The Netherlands.

Howard H. Chen. "Breaking Cycles and Vertical Constraints in Deutsch's New and More Difficult Channel-Routing Problems." Aug. 14, 1989. Yorktown Heights, NY.

T.W. Her & D.F. Wong. "On Over-the-Cell Channel Routing with Cell Orientations Consideration." Jun. 1, 1995. NY.

P. Saratachandran "Dynamic Programming Approach for Multilayers Neural Network Optimization," IEEE, pp. 1397-1402, Jul. 1991.

Primary Examiner—Kevin J. Teska

Assistant Examiner—Vuthe Siek

Attorney, Agent, or Firm—Thomas E. Schatzel; Law Offices of Thomas E. Schatzel

[57] ABSTRACT

A method for optimal track assignment in a grid-based channel router. Initially, interconnection information is extracted from a global routing result. Multiple pin nets derived from the interconnection information are decomposed into simpler mapped segments. A channel grid map is then built and marked with existing objects. Next, a vertical constraint graph specifying the relative positions of the mapped segments is constructed. A first track is computed. A track assignment loop is repeated until all requisite connections are realized. The track assignment loop includes the steps of breaking cycles and long paths and collecting a set of feasible links. One or more weighting functions are assigned to each such feasible link. A dynamic programming approach is used to select an optimal set of feasible links according to the weighting functions. In addition, an optimal set of feasible links corresponding to unpreferred layers is collected by applying dynamic programming. Finally, the chosen feasible links are physically realized on the current track.

16 Claims, 6 Drawing Sheets

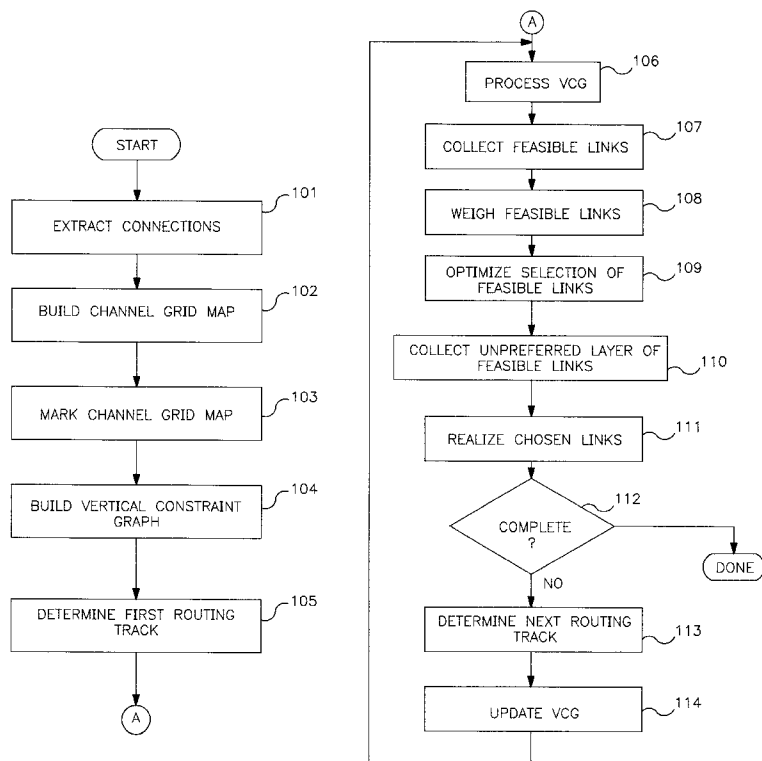

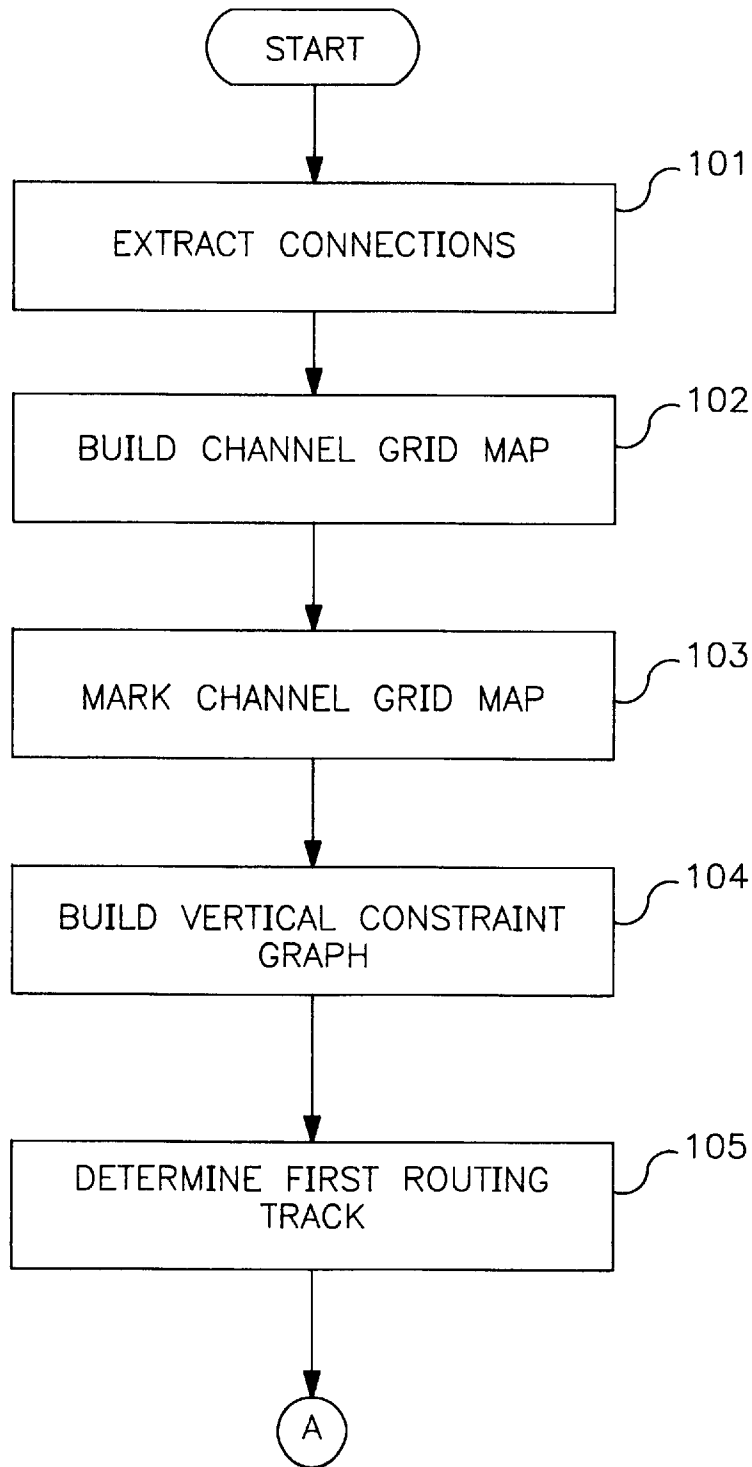

FIG. 1A

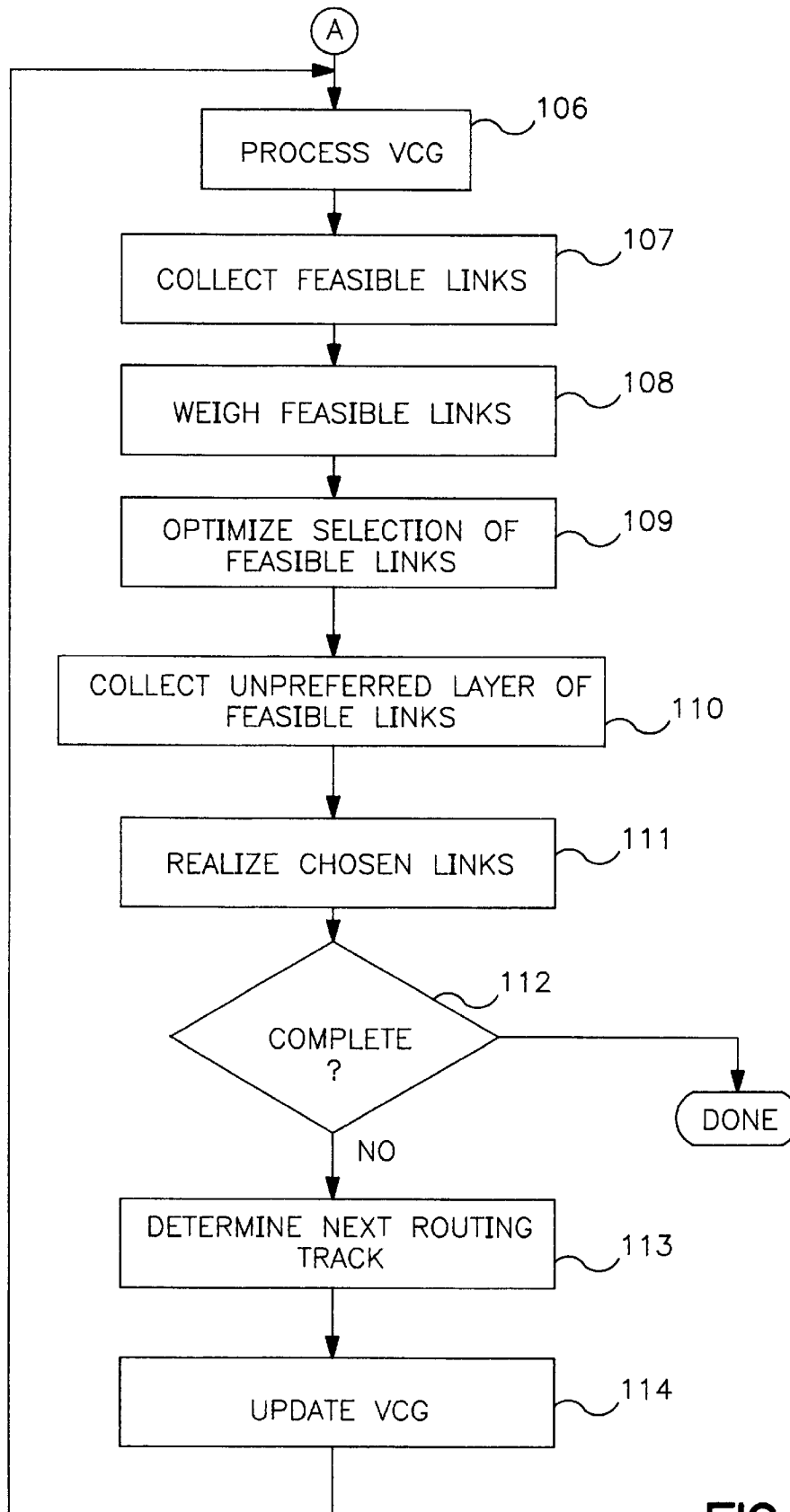

FIG. 1B

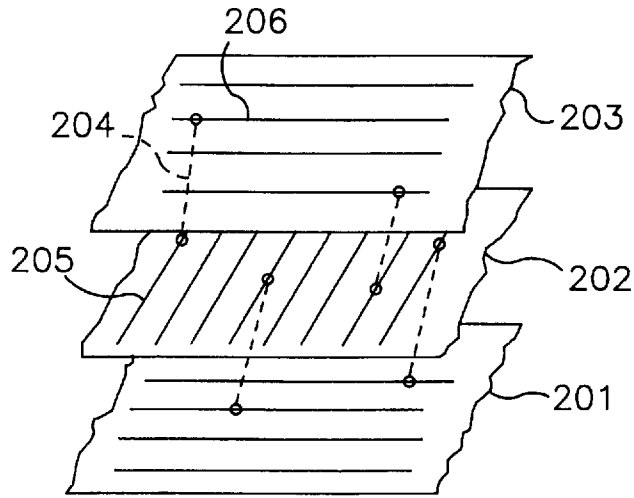

FIG. 2

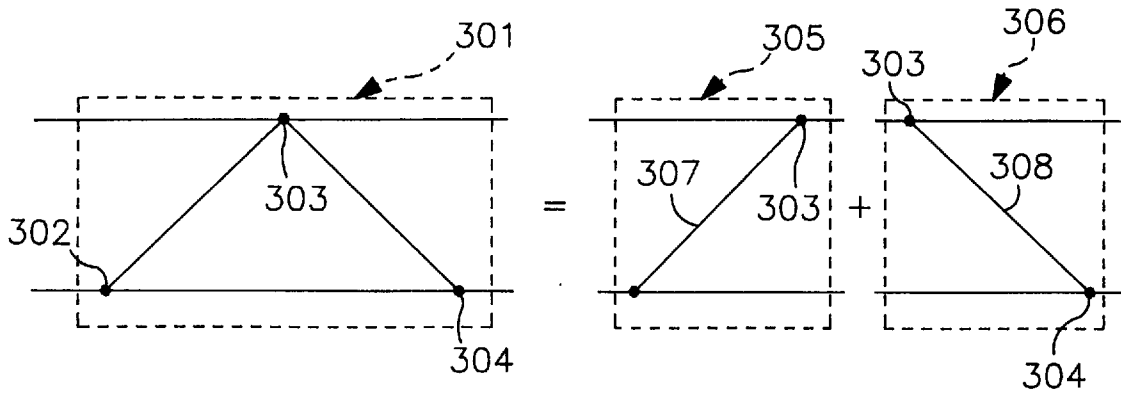

FIG. 3

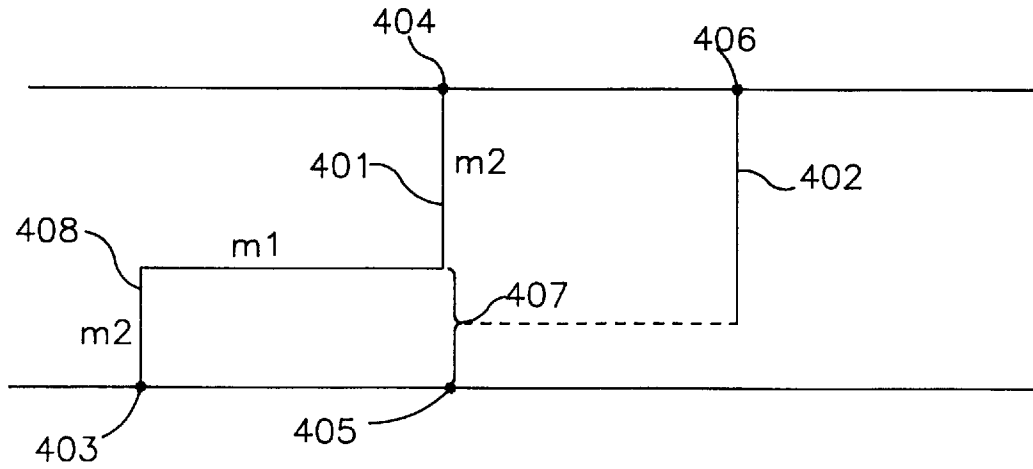

FIG. 4

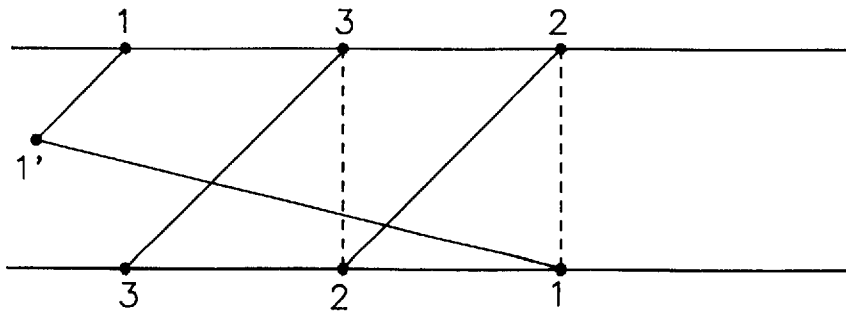
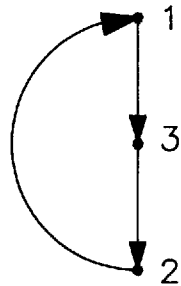

FIG. 5

Explore Litigation Insights

Docket Alarm provides insights to develop a more informed litigation strategy and the peace of mind of knowing you're on top of things.

Real-Time Litigation Alerts



Keep your litigation team up-to-date with **real-time alerts** and advanced team management tools built for the enterprise, all while greatly reducing PACER spend.

Our comprehensive service means we can handle Federal, State, and Administrative courts across the country.

Advanced Docket Research



With over 230 million records, Docket Alarm's cloud-native docket research platform finds what other services can't. Coverage includes Federal, State, plus PTAB, TTAB, ITC and NLRB decisions, all in one place.

Identify arguments that have been successful in the past with full text, pinpoint searching. Link to case law cited within any court document via Fastcase.

Analytics At Your Fingertips



Learn what happened the last time a particular judge, opposing counsel or company faced cases similar to yours.

Advanced out-of-the-box PTAB and TTAB analytics are always at your fingertips.

API

Docket Alarm offers a powerful API (application programming interface) to developers that want to integrate case filings into their apps.

LAW FIRMS

Build custom dashboards for your attorneys and clients with live data direct from the court.

Automate many repetitive legal tasks like conflict checks, document management, and marketing.

FINANCIAL INSTITUTIONS

Litigation and bankruptcy checks for companies and debtors.

E-DISCOVERY AND LEGAL VENDORS

Sync your system to PACER to automate legal marketing.