



US010003553B2

(12) **United States Patent**
Konda

(10) **Patent No.:** **US 10,003,553 B2**

(45) **Date of Patent:** ***Jun. 19, 2018**

(54) **OPTIMIZATION OF MULTI-STAGE
HIERARCHICAL NETWORKS FOR
PRACTICAL ROUTING APPLICATIONS**

(71) Applicant: **Venkat Konda**, San Jose, CA (US)

(72) Inventor: **Venkat Konda**, San Jose, CA (US)

(73) Assignee: **Konda Technologies Inc.**, San Jose,
CA (US)

(*) Notice: Subject to any disclaimer, the term of this
patent is extended or adjusted under 35
U.S.C. 154(b) by 107 days.

This patent is subject to a terminal dis-
claimer.

(21) Appl. No.: **15/140,470**

(22) Filed: **Apr. 28, 2016**

(65) **Prior Publication Data**

US 2016/0261525 A1 Sep. 8, 2016

(51) **Int. Cl.**
H04L 12/933 (2013.01)
H04L 29/06 (2006.01)

(52) **U.S. Cl.**
CPC **H04L 49/1515** (2013.01); **H04L 29/06081**
(2013.01); **H04L 49/109** (2013.01); **H04L**
65/4076 (2013.01)

(58) **Field of Classification Search**
CPC H04L 49/1515; H04L 65/4076; H04L
29/06081
See application file for complete search history.

(56) **References Cited**

U.S. PATENT DOCUMENTS

5,153,843 A 10/1992 Batcher
5,345,444 A * 9/1994 Cloonan H04L 12/5601
370/381

5,451,936 A 9/1995 Yang et al.
5,541,914 A * 7/1996 Krishnamoorthy ... H04L 49/254
370/427
5,654,695 A * 8/1997 Olnowich G06F 13/4022
340/2.23
6,018,523 A 1/2000 Even
6,091,723 A * 7/2000 Even H04L 49/1507
340/2.21
6,185,220 B1 2/2001 Muthukrishnan et al.
(Continued)

OTHER PUBLICATIONS

Ronald I. Greenberg, "The Fat-Pyramid and Universal Parallel
Computation Independent of wire delay" IEEE Trans. Computers,
43(12):1358-1364, Dec. 1994.

(Continued)

Primary Examiner — Rasheed Gidado

(57) **ABSTRACT**

Significantly optimized multi-stage networks, useful in wide
target applications, with VLSI layouts using only horizontal
and vertical links to route large scale sub-integrated circuit
blocks having inlet and outlet links, and laid out in an
integrated circuit device in a two-dimensional grid arrange-
ment of blocks are presented. The optimized multi-stage
networks in each block employ several rings of stages of
switches with inlet and outlet links of sub-integrated circuit
blocks connecting to rings from either left-hand side only, or
from right-hand side only, or from both left-hand side and
right-hand side; and employ shuffle exchange links where
outlet links of cross links from switches in a stage of a ring
in one sub-integrated circuit block are connected to either
inlet links of switches in the another stage of a ring in the
same or another sub-integrated circuit block.

20 Claims, 19 Drawing Sheets

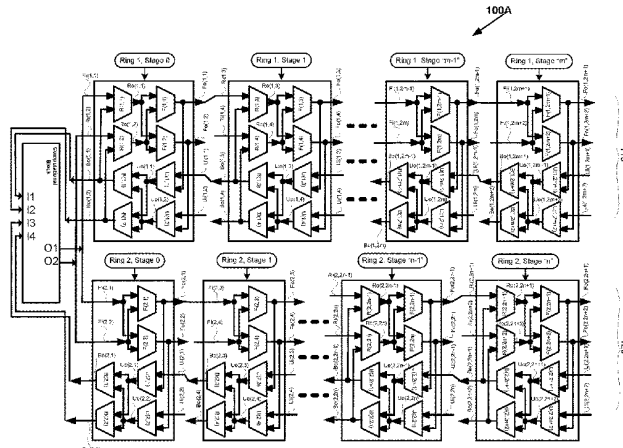

(56)

References Cited

U.S. PATENT DOCUMENTS

6,335,930	B1 *	1/2002	Lee	H04L 49/101 370/387
6,469,540	B2 *	10/2002	Nakaya	H03K 19/17728 326/38
6,940,308	B2	9/2005	Wong		
7,440,449	B2 *	10/2008	Carson	G06T 7/20 257/499
8,170,040	B2	5/2012	Konda		
8,269,523	B2	9/2012	Konda		
8,270,400	B2	9/2012	Konda		
8,363,649	B2	1/2013	Konda		
8,898,611	B2	11/2014	Konda		
9,374,322	B2	6/2016	Konda		
9,529,958	B2	12/2016	Konda		
2003/0117946	A1 *	6/2003	Fontana	H04L 12/437 370/216
2011/0037498	A1 *	2/2011	Konda	G06F 17/5077 326/41
2012/0269190	A1 *	10/2012	Konda	G06F 17/5054 370/388

OTHER PUBLICATIONS

Hypertree: A Multiprocessor Interconnection Topology, by James R. Goodman and Carlo H Sequin, Computer Science Technical Report #427, Dept. of EECS, University of California.

Data Movement Techniques for the pyramid computer, Russ Miller and Quentin F. Stout, SIAM Journal on Computing, vol. 16, No. 1, pp. 38-60, Feb. 1987.

C. Clos, "A Study of Non-Blocking Switching Networks," Bell System Technical Journal, 32:406-424, 1953.

A. DeHon, "Balancing Interconnect and Computation in a Reconfigurable Computing Array," ACM Int. Symp. on FPGA, pp. 69-78, Feb. 1999.

Chihming Chang, Rami Melhem, "Arbitrary Size Benes Networks", Journal: Parallel Processing Letters—PPL, vol. 7, No. 3, pp. 279-284, 1997.

Hoda El-Sayed and Abdou Youssef, "The r-truncated Benes Networks and their Randomized Routing Algorithms" 1997 Intl Conf on Parallel and Dist Sys, Seoul, Korea, Dec. 1997.

Guy Lemieux and David Lewis, "Using Sparse Crossbars within LUT Clusters", Procds of the ACM/SIGDA Intl Symp on Field Prog Gate Arrays 2001, Feb. 11-13, 2001, Monterey, CA.

P. Manuel, W. K. Qureshi, A. William, A. Muthumalai, "VLSI layout of Benes networks," J. of Discrete Math. Sci. & Cryptography, vol. 10, No. 4, pp. 461-472, 2007.

Quinn, Michael J, "Parallel Computing: Theory and Practice", 2nd. ed., 1994, McGraw Hill Series in computer Science, Networks, and parallel computing, ISBN 0-07-051294-9.

A. DeHon, "Unifying Mesh- and Tree-Based Programmable Interconnect," IEEE Trans. on Very Large Scale Int. Systems, vol. 12, No. 10, pp. 1051-1065, Oct. 2004.

Guy Lemieux and David Lewis. Analytical framework for switch block design. In Intl. Conference on Field Programmable Logic and Applications, pp. 122-131, Sep. 2002.

Chen, G; Lau, FCM, "A tight layout of the cube-connected cycles", The 4th International Conference on High Perf. Computing, Bangalore, India, Dec. 18-21, 1997, p. 422-427.

Michael Shyu, Yu-Dong Chang, Guang-Ming Wu, and Yao-Wen Chang, Generic universal switch blocks. IEEE Transactions on Computers, 49(4):348-359, Apr. 2000.

Y. Yamada, et. al., "Folded Fat H-Tree: an interconnection topology for Dynamically Reconfigurable Processor Array", Embed and Ubiqu. Cmpting, Intl Conf. EUC 2004.

A. DeHon. Balancing Interconnect and Computation in a Reconfigurable Computing Array (or, why you don't really want 100% LUT utili). In Proc. of intl. symp. on FPGAs, Feb. 1999.

André DeHon. Compact, Multilayer Layout for Butterfly Fat-Tree. In Twelfth Annual ACM Symposium on Parallel Algs and Architectures (SPAA 2000), pp. 206-215, Jul. 9-12, 2000.

V. P. Roychowdhury et. al., "Segmented Channel Routing," IEEE Trans on Computer-Aided Design of Integrated Circuits and Systems, vol. 12, No. 1, pp. 79-95, Jan. 1993.

Ivo Dobbelaere, Mark Horowitz, and Abbas El Gamal. Regenerative feedback repeaters for programmable interconnections. IEEE Journal of Solid-State Circuits, 30(11), 1995.

F. Petrini et. al., k-ary n-trees: High performance networks for massively parallel architectures, in: Proceedings of the 11th Intl Parallel Proc. Symp., IPPS'97, pp. 87-93.

P. Pande et al. "Evaluation of MP-SoC Interconnect Architectures: a Case Study", Proceedings of 4th IWSOC, Banff, Alberta, Canada, Jul. 19-21, 2004.

Yeh, C.-H., Varvarigos, E.A., Parhami, B.: Multilayer VLSI layout for interconnection networks. In: Proc. Intl. Conf. on Parallel Processing, 2000.

M. Lin, A. El Gamal, "A Low-Power Field-Programmable Gate Array Routing Fabric," IEEE Transactions on Very Large Scale Integration, vol. 17, No. 10, pp. 1481-1494, Oct. 2009.

Avior, A et. al., A Tight Layout of the Butterfly Network. Proc. 8-th Annual ACM Symp. on Parallel Alg. and Arch. (SPAA '96), ACM Press Ed., 1996, pp. 170-175.

A. El Gamal et. al., "An Architecture for Electrically Configurable Gate Arrays," IEEE Jnl of Solid-State Circuits, vol. 24, No. 2, pp. 394-398, Apr. 1989.

Vaughn Betz et. al., Directional bias and non-uniformity in FPGA global routing architectures. In IEEE/ACM Intl. Conference on Computer-Aided Design, pp. 652-659, San Jose, 96.

W. Tsu et. al., "HSRA: High-Speed, Hierarchical Synchronous Reconfigurable Array," in Procds. of the Intl. Symp. on Field-Programmable Gate Arrays, Feb. 1999, pp. 125-134.

André DeHon. Rent's Rule Based Switching Requirements. In System-Level Interconnect Prediction (SLIP 2001), pp. 197-204, Mar. 31-Apr. 1, 2001.

Guy Lemieux et. al., Generating highly routable sparse crossbars for PLDs. In ACMISIGDA Int'l. Symposium on Field Programmable Gate Arrays, pp. 155-164, Monterey, CA, Feb. 2000.

S. Sivaswamy et. al., "HARP: hard-wired routing pattern FPGAs", FPGA'05, Monterey, California, USA, Feb. 20-22, 2005.

Yeh, C.-H., E.A. Varvarigos, and B. Parhami, "Efficient VLSI layouts of hypercubic networks," Proc. Symp. Frontiers of Massively Parallel Computation, Feb. 1999.

Bhatt, S. N. and Leighton, F. T. 1984. A framework for solving VLSI graph layout problems. J. Comput. Syst. Sci. 28, 300-343.

* cited by examiner

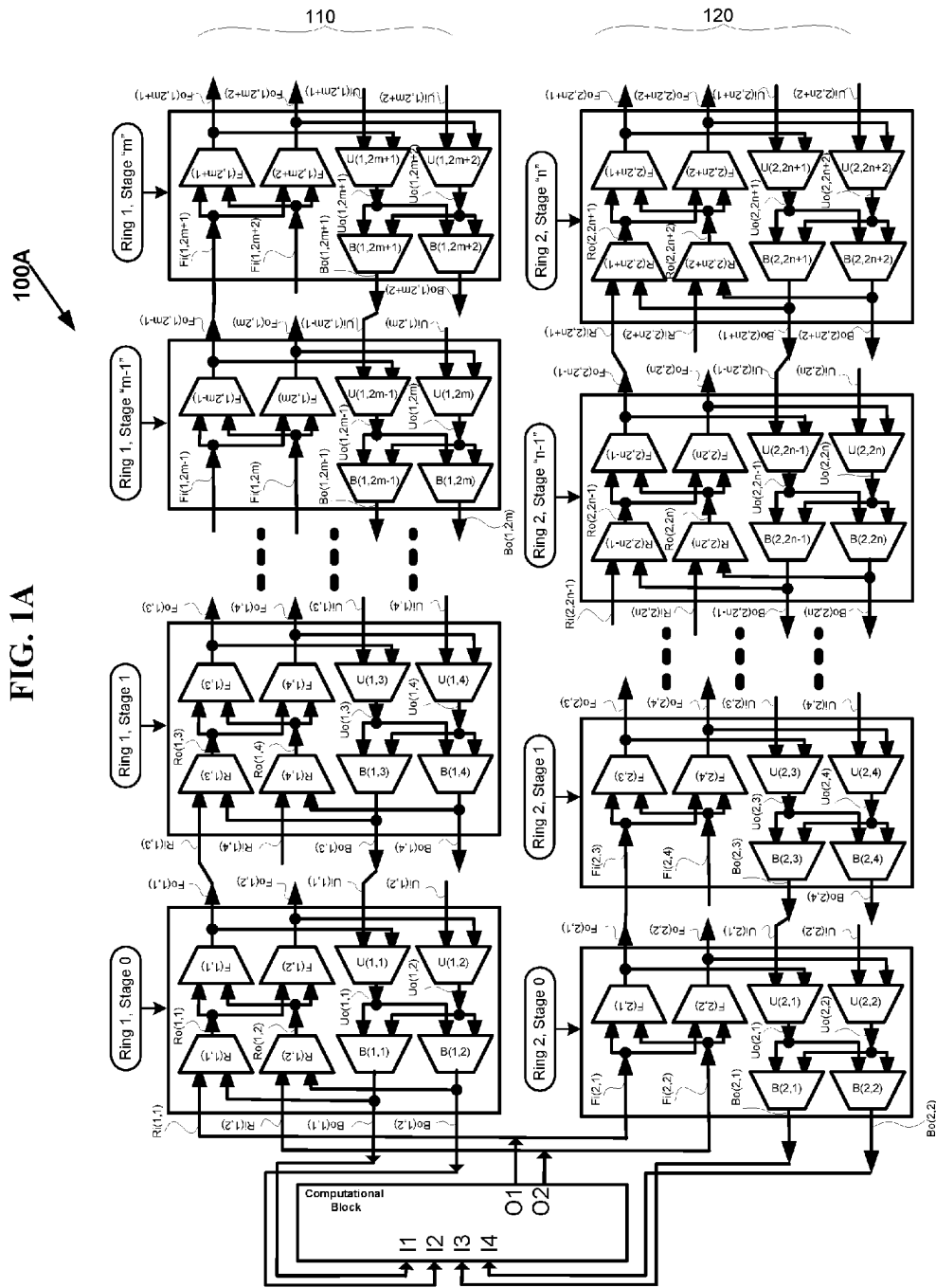

FIG. 1A

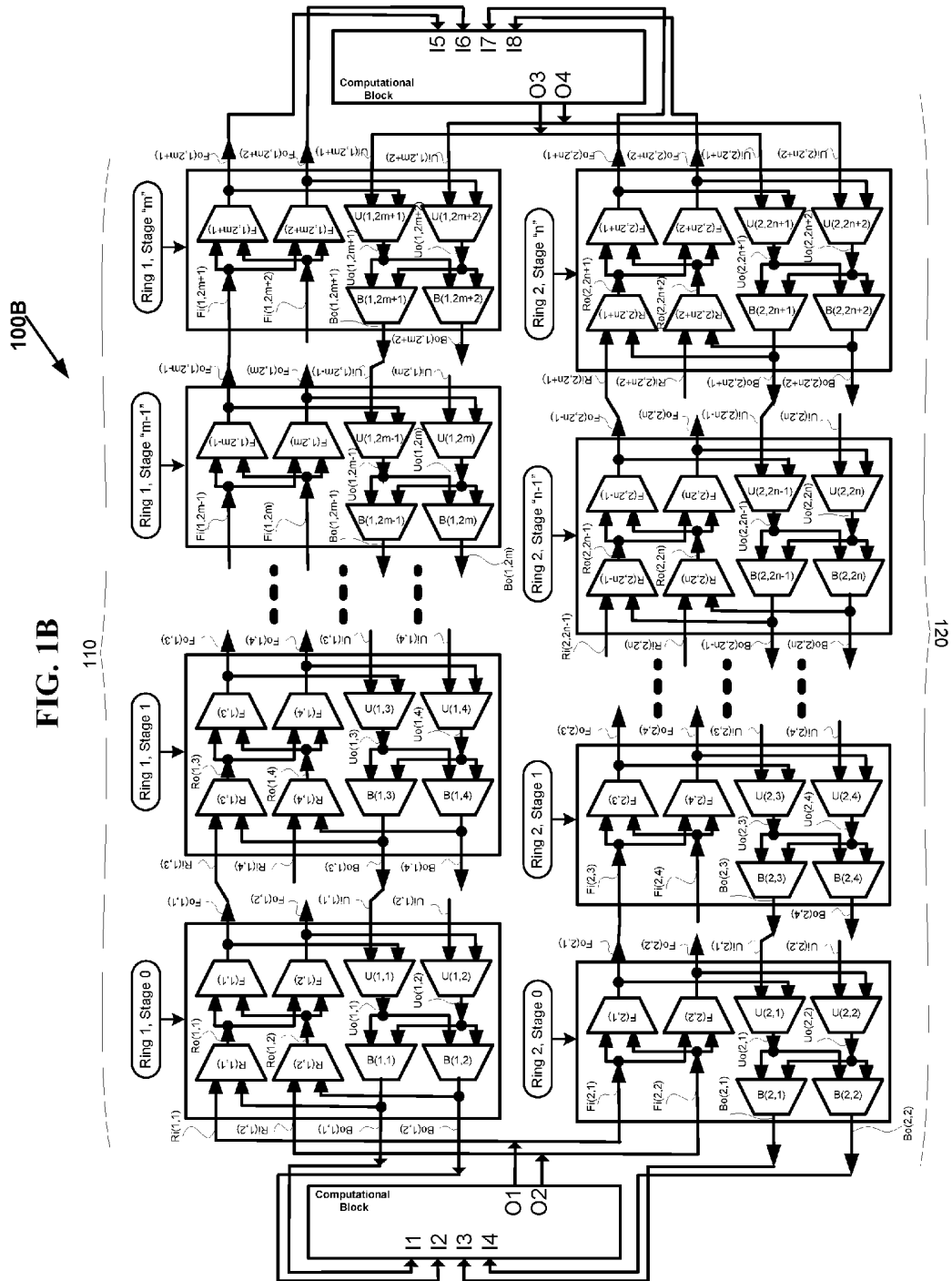

FIG. 1B

FIG. 2A 200A

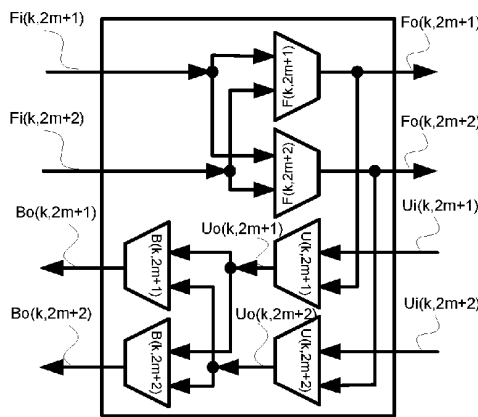

FIG. 2B 200B

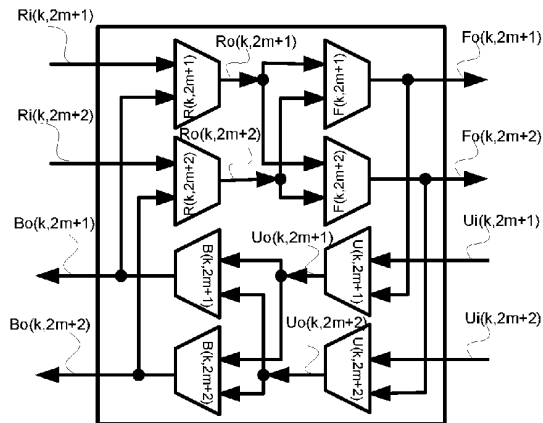

FIG. 2C 200C

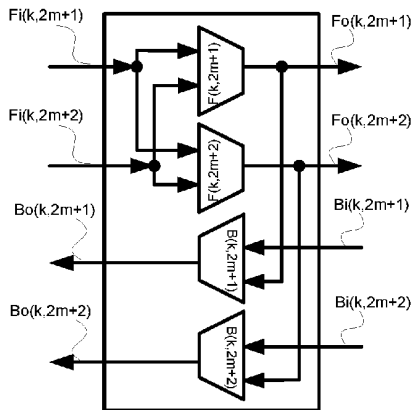

FIG. 2D 200D

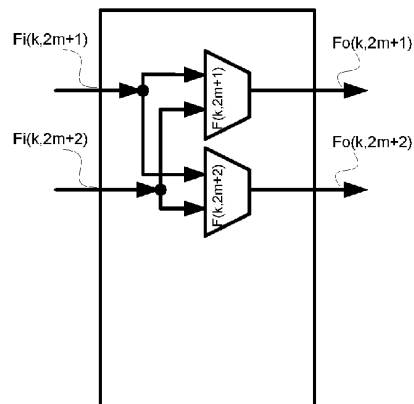

FIG. 2E

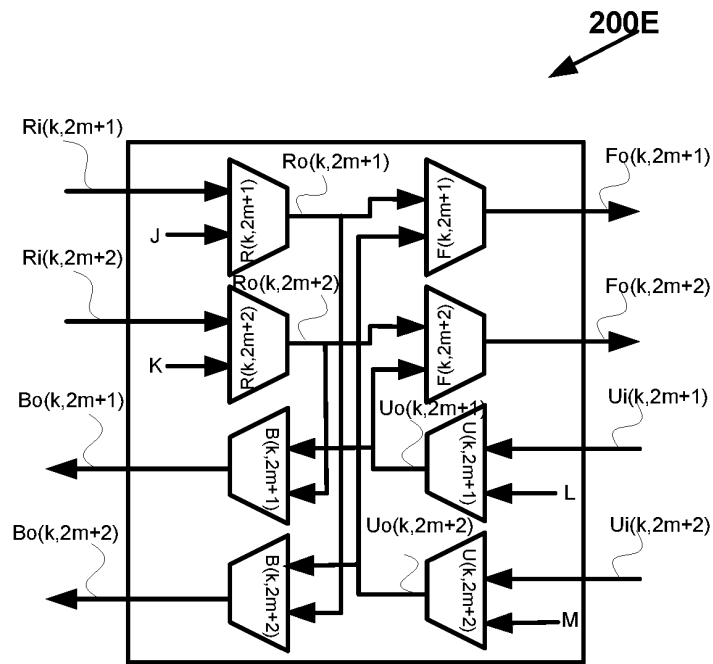

FIG. 3A

300A

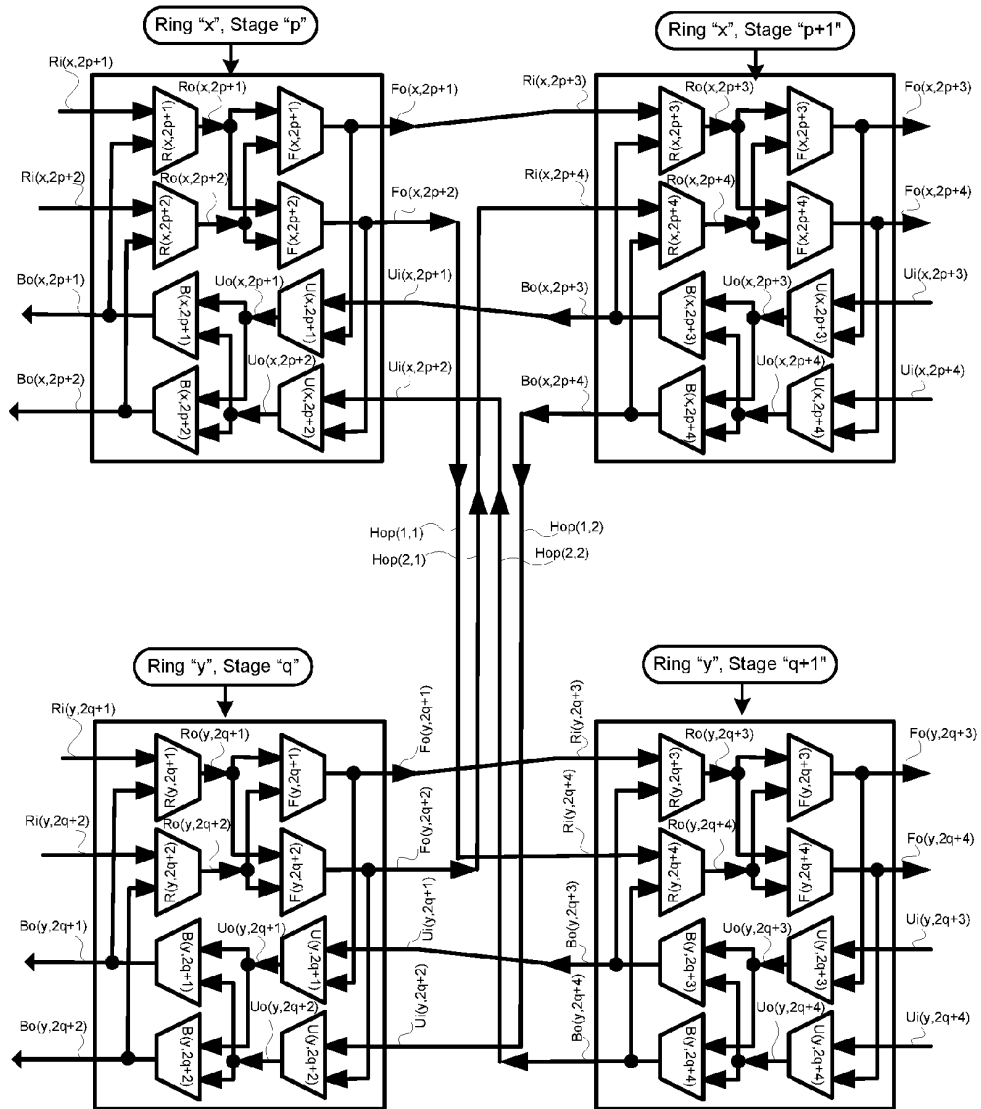

FIG. 3B

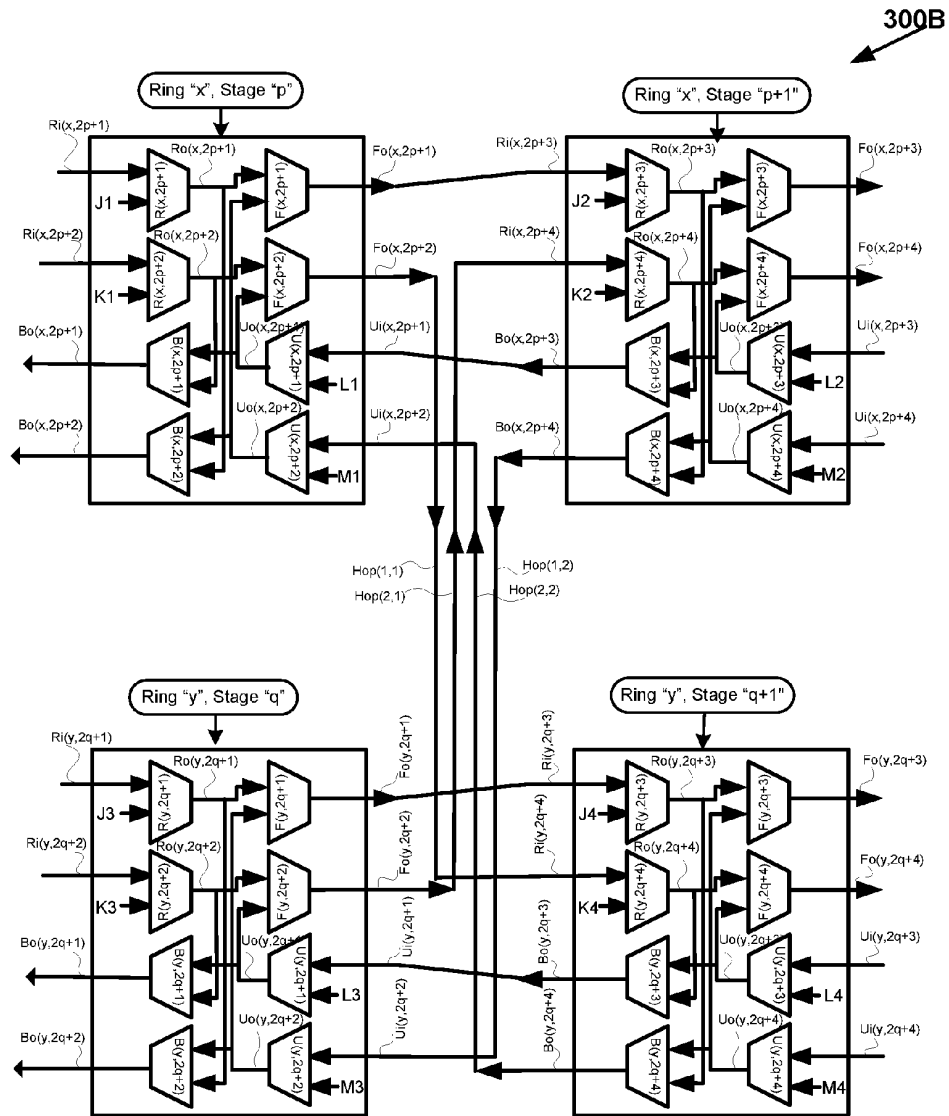

FIG. 4

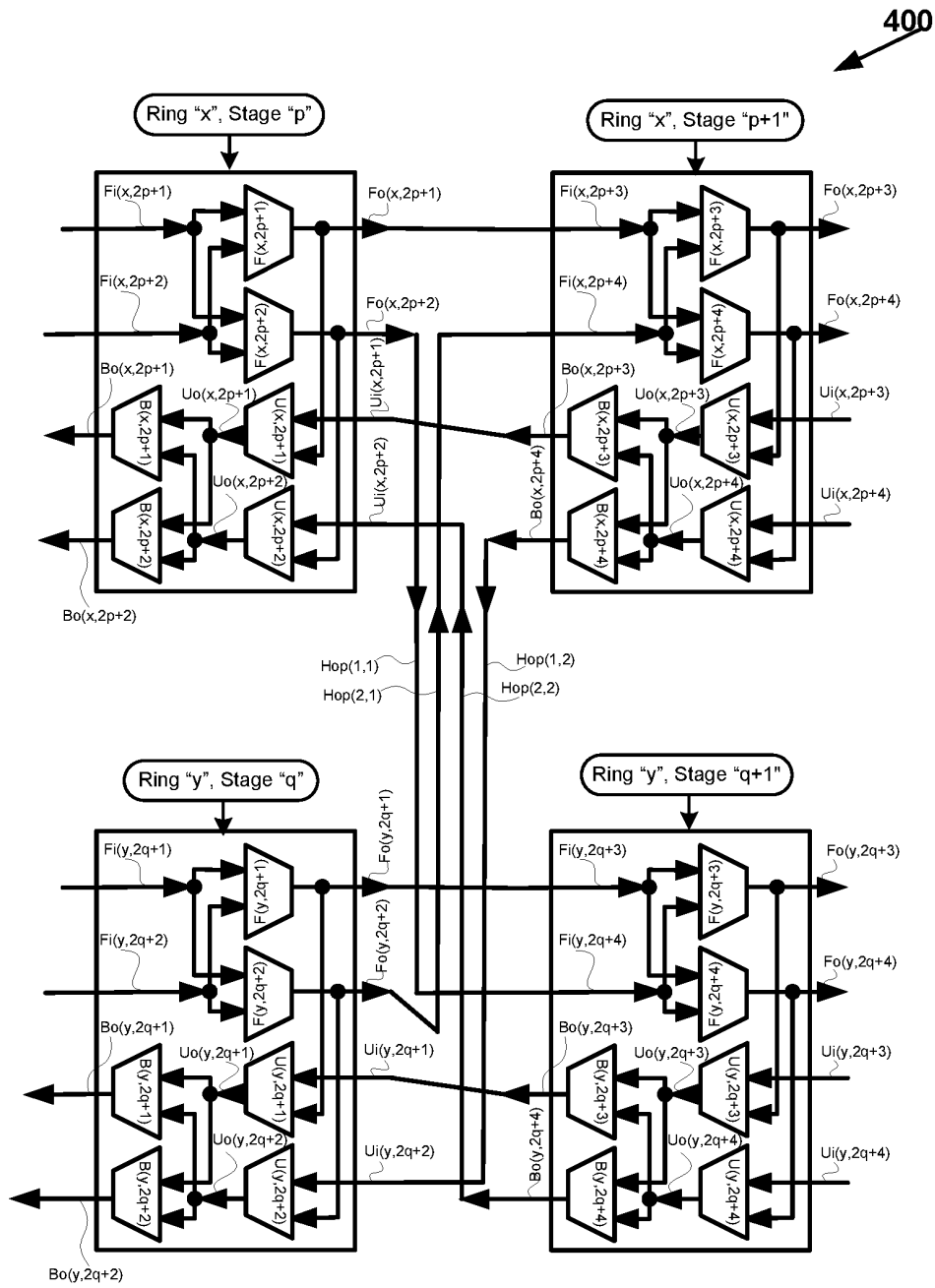

FIG. 5

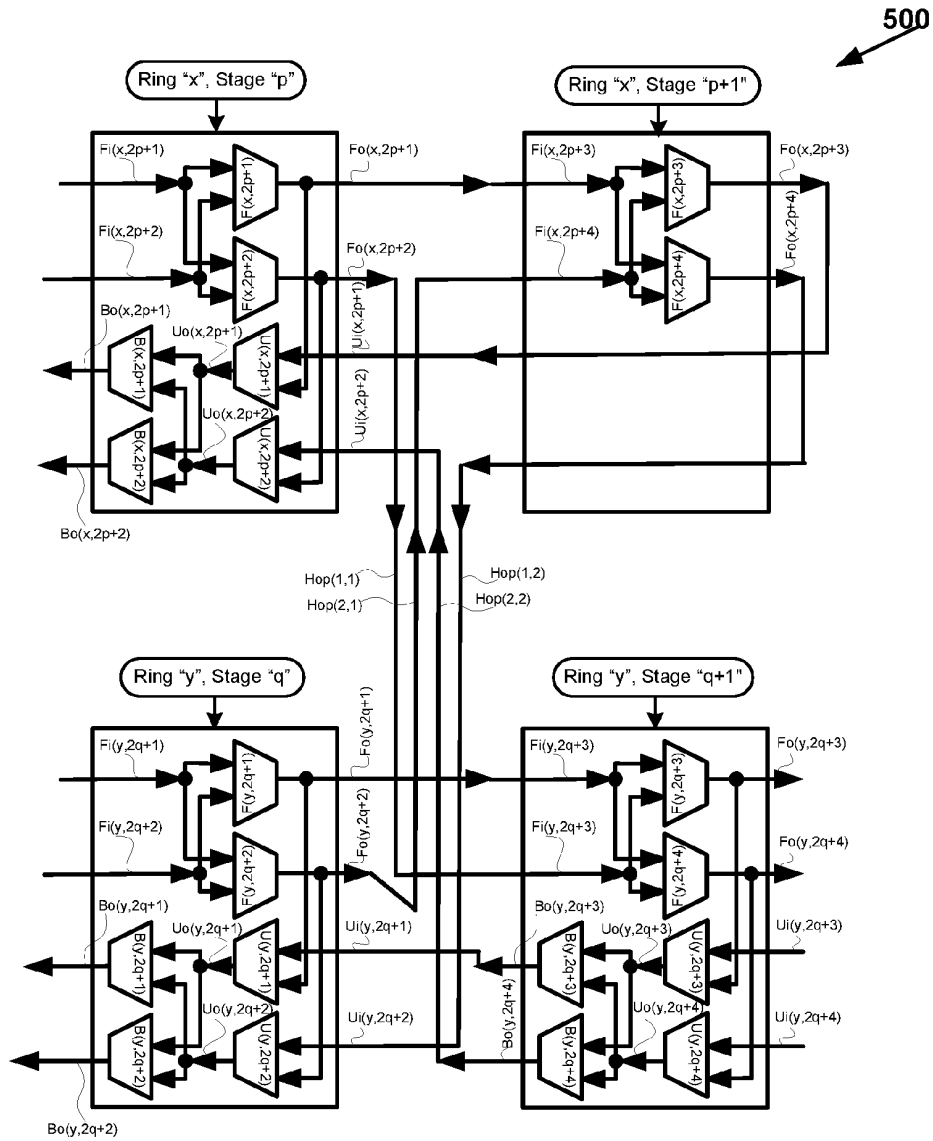

FIG. 6

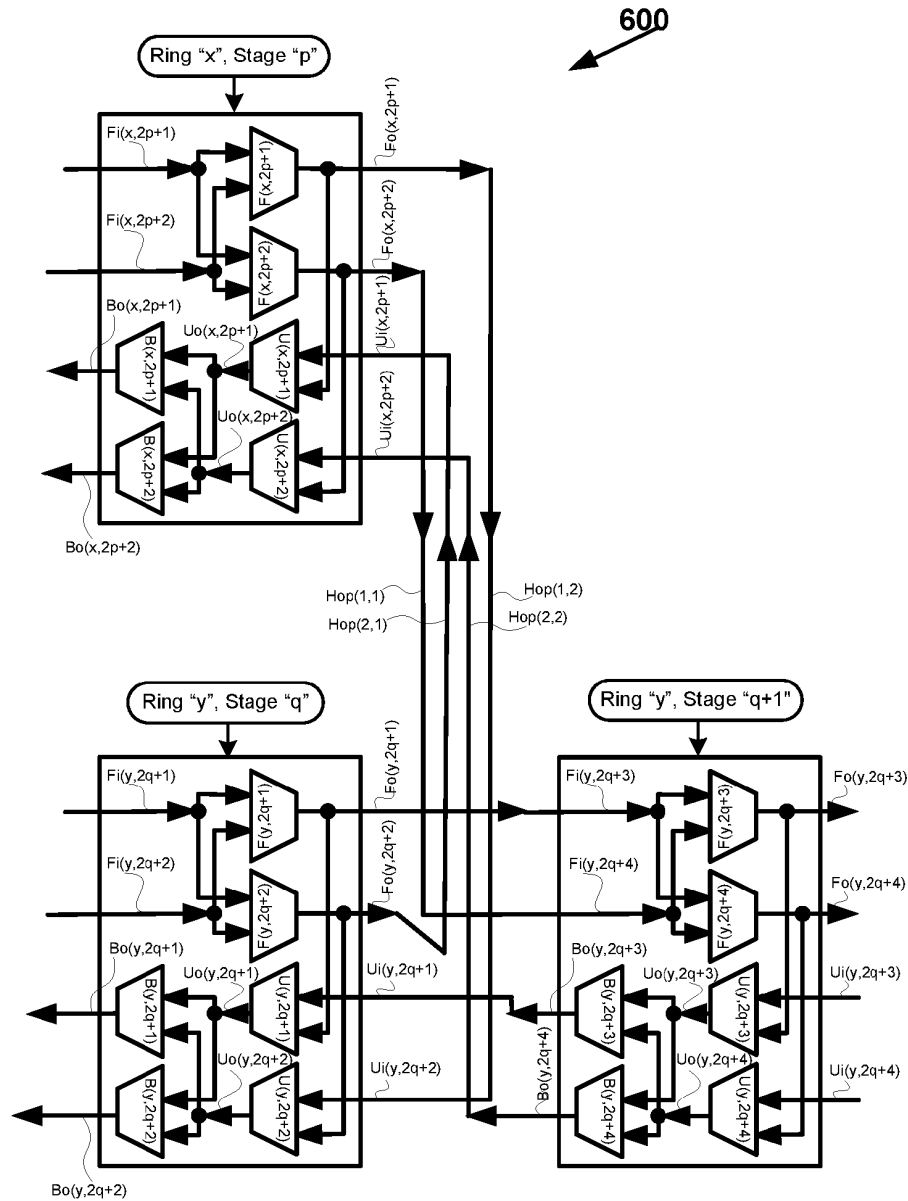
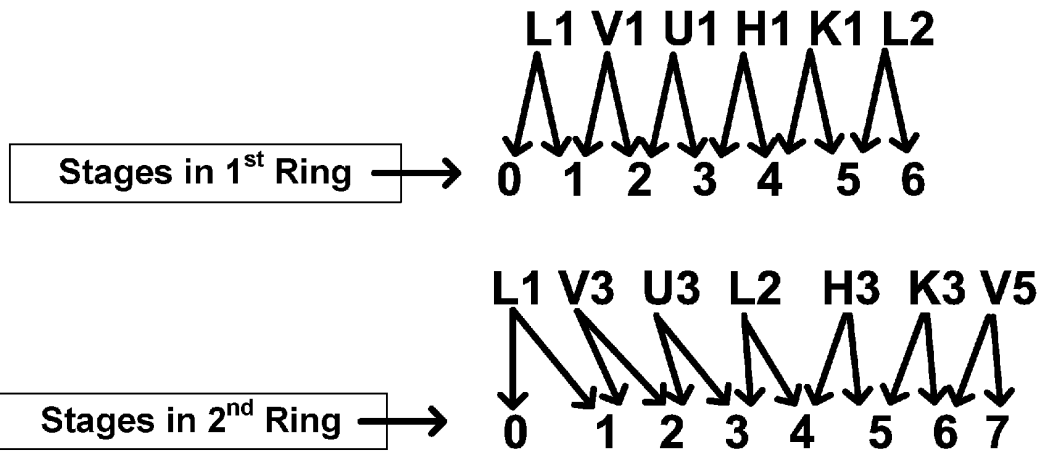

FIG. 7

700



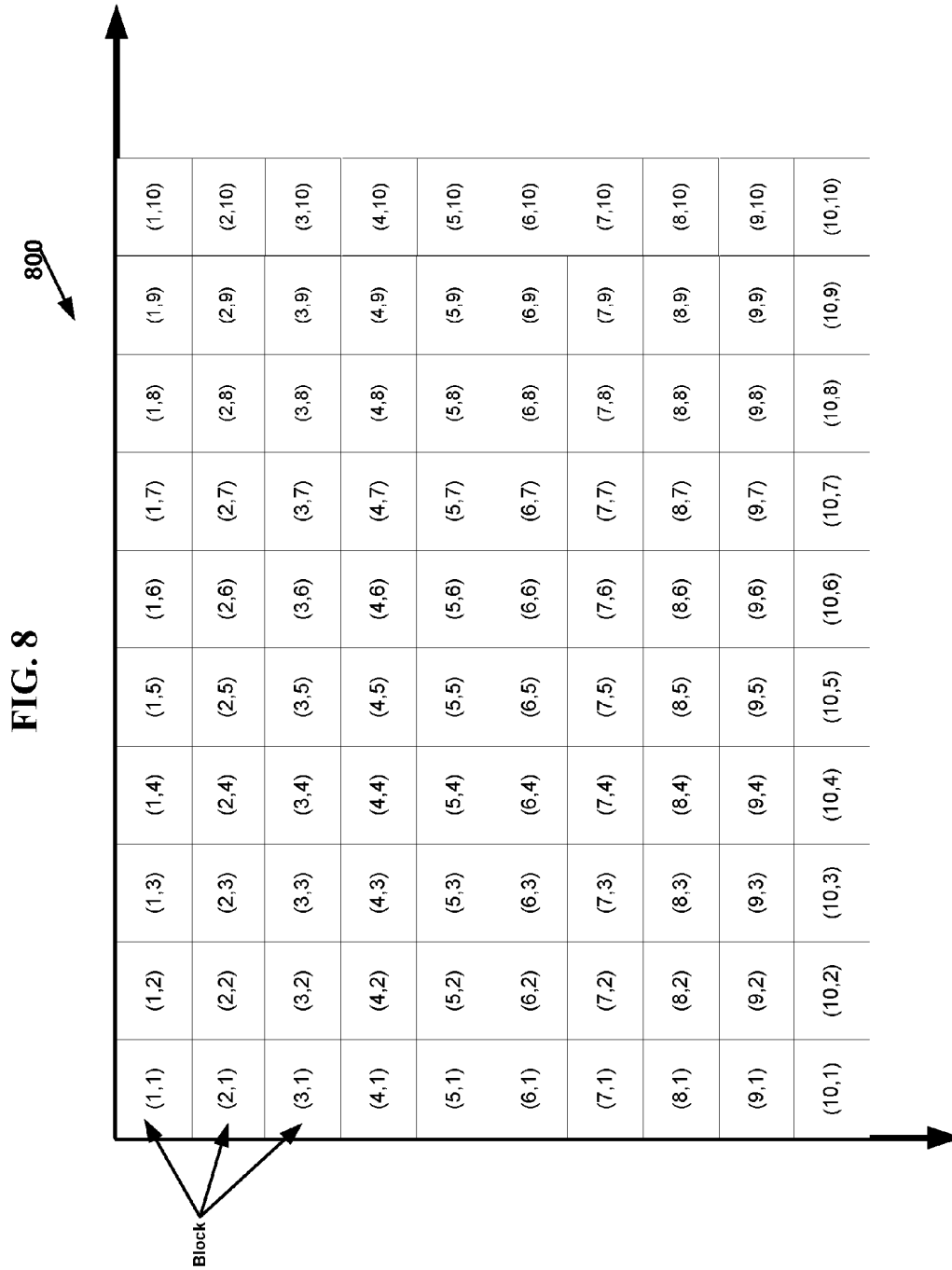

FIG. 9A 900A

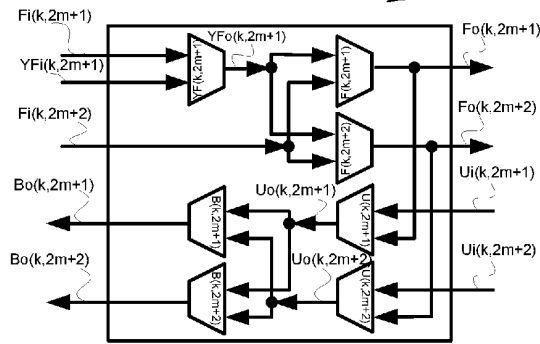

FIG. 9B 900B

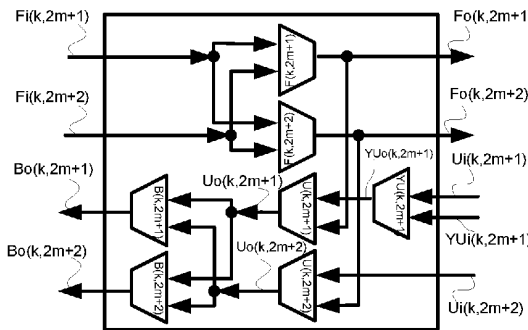

FIG. 9C 900C

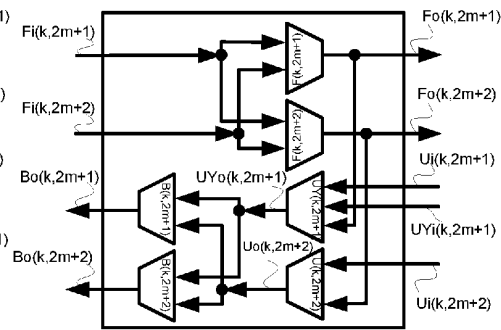

FIG. 9D 900D

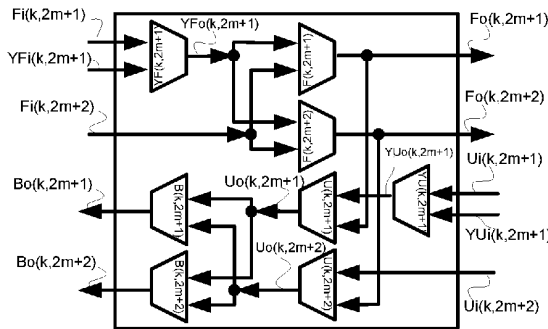
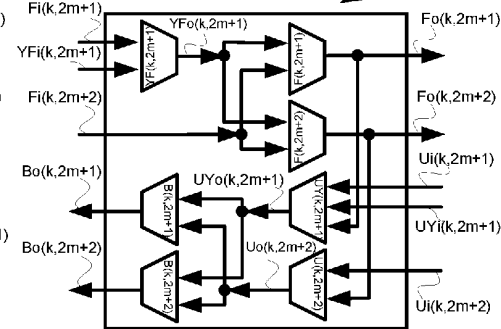

FIG. 9E 900E



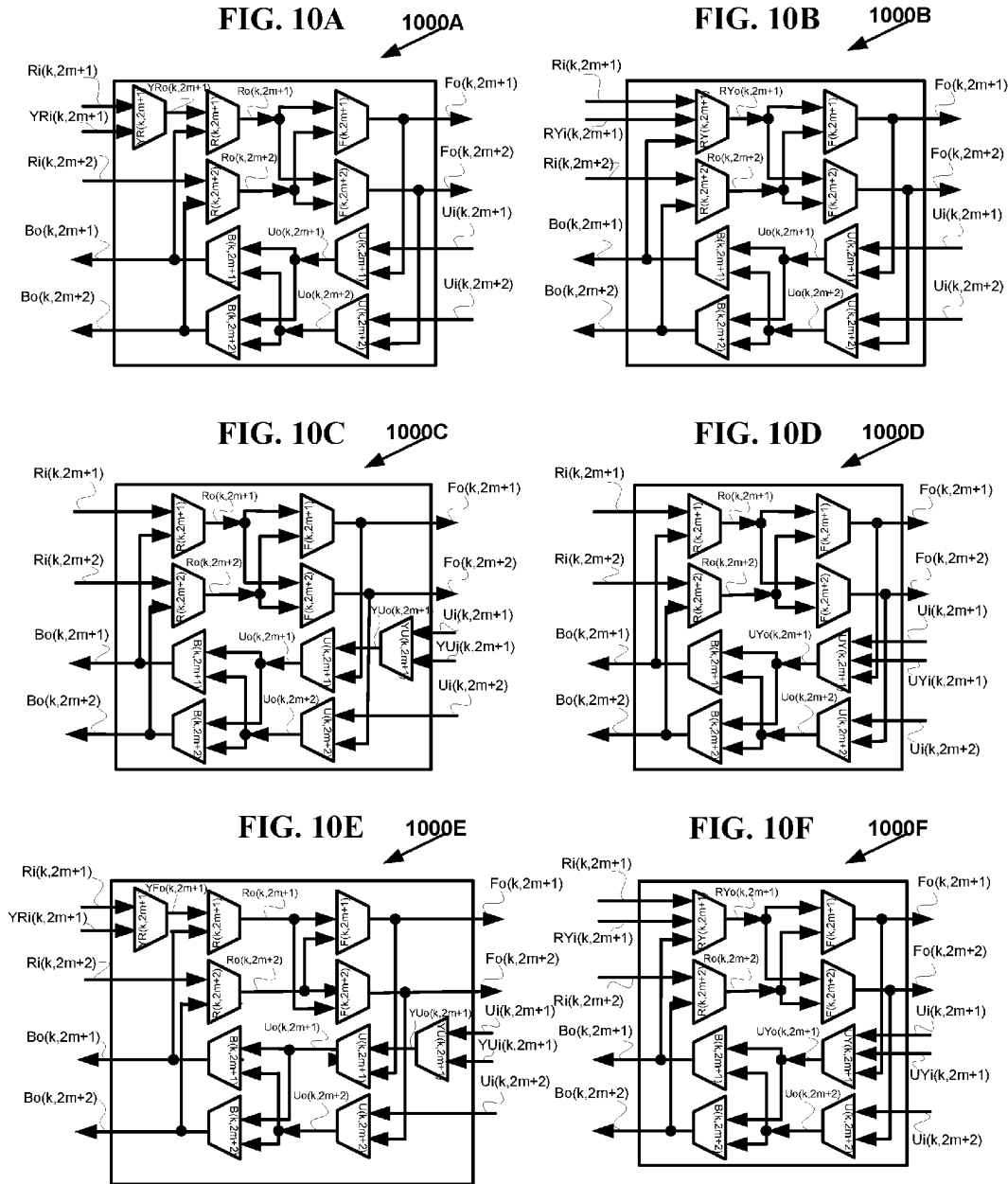

FIG. 11A

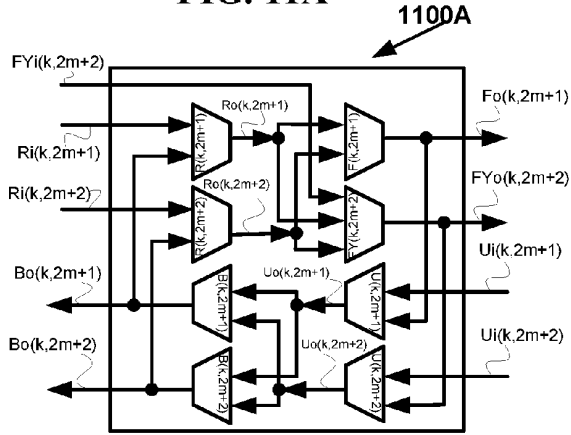

FIG. 11B

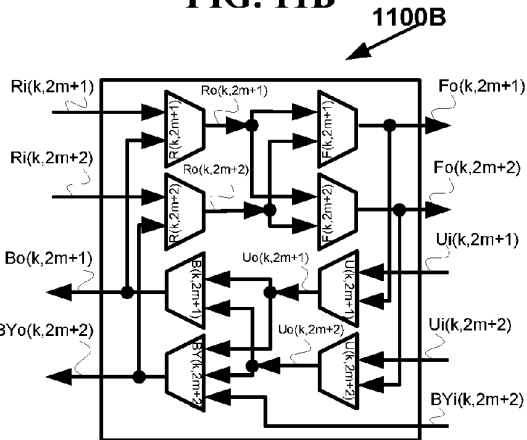

FIG. 11C

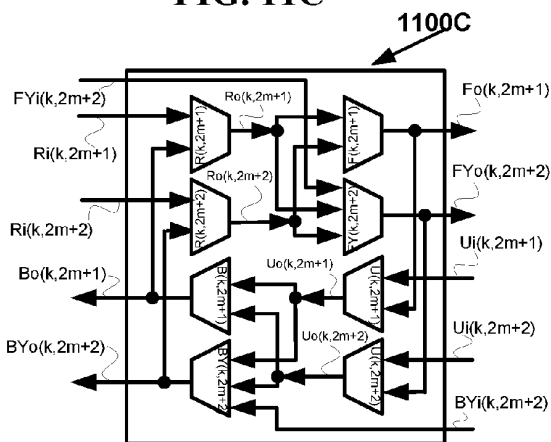
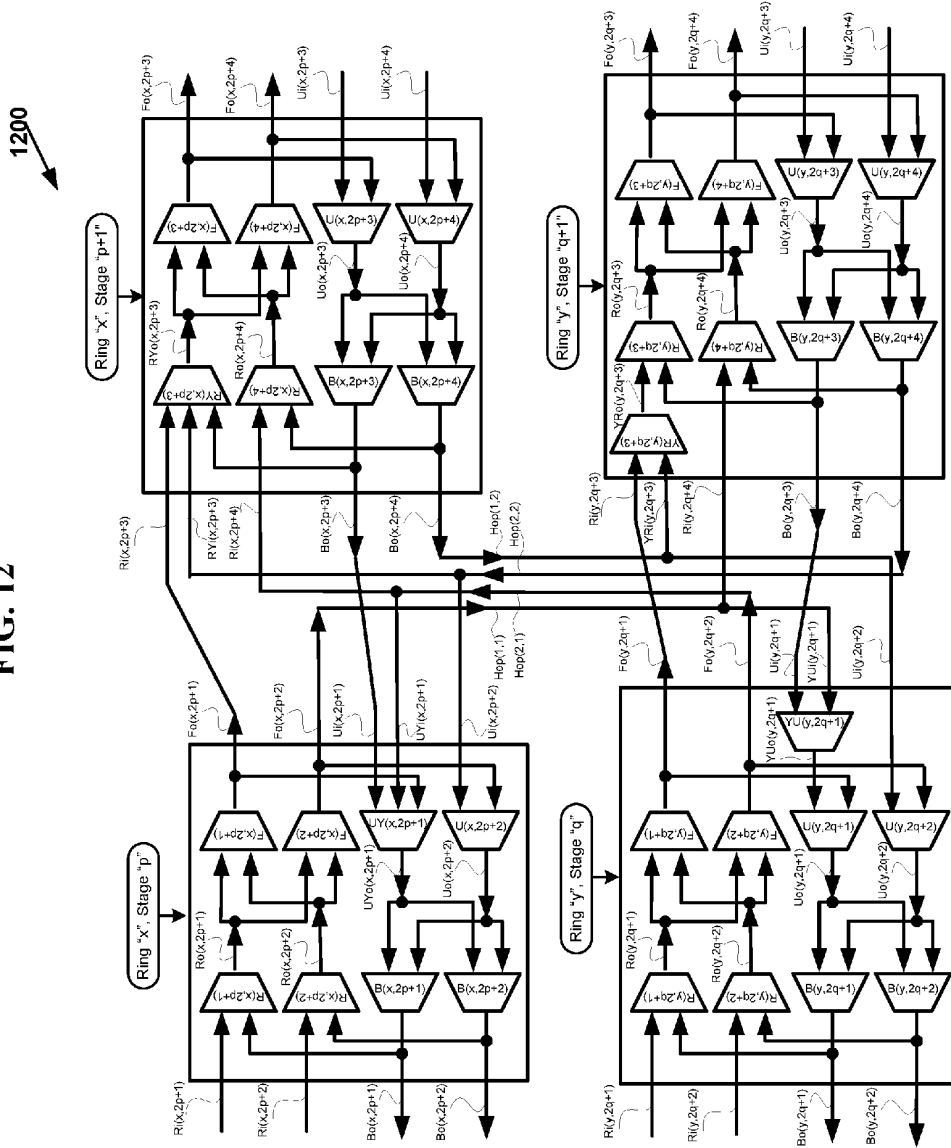
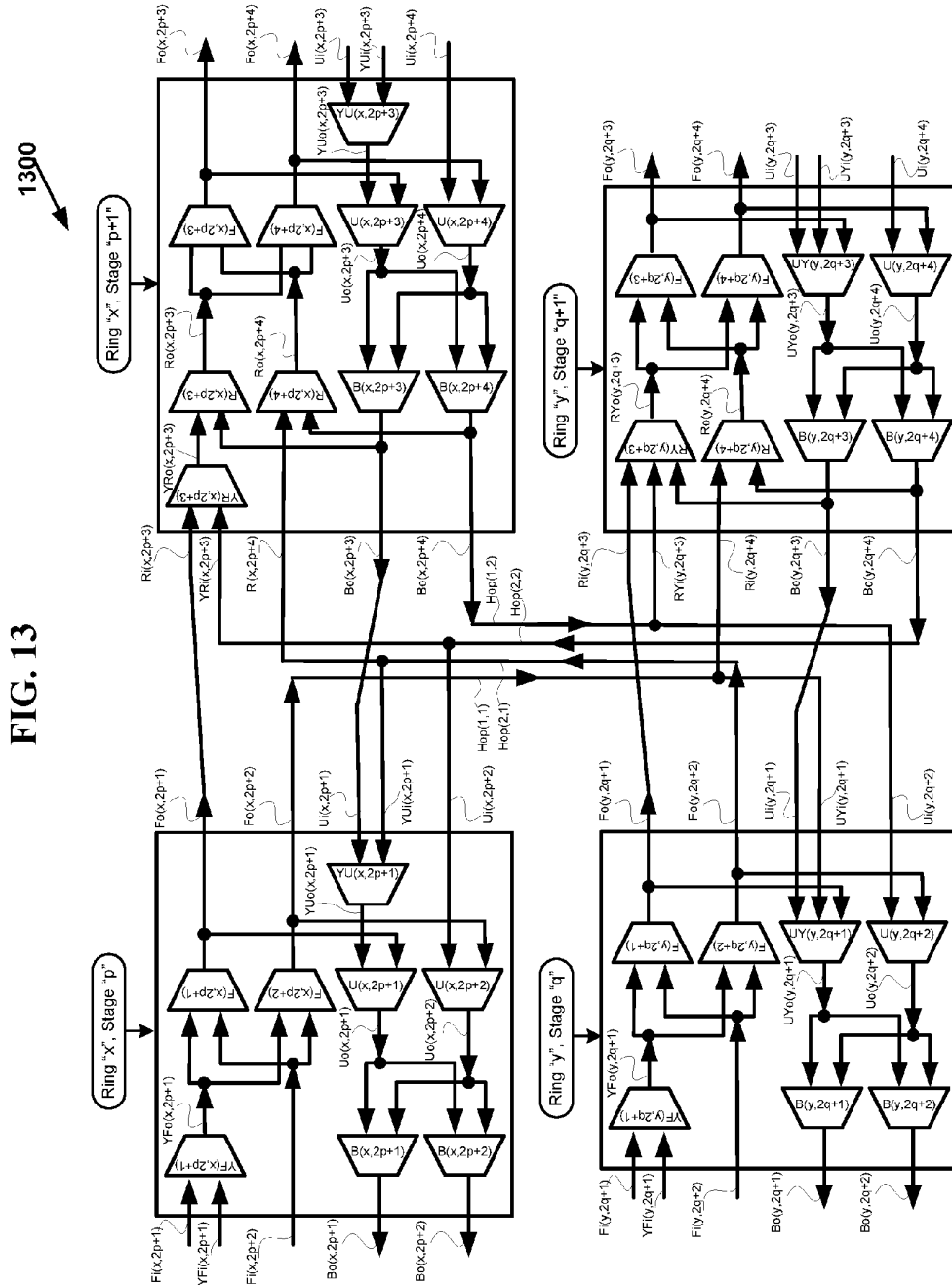

FIG. 12





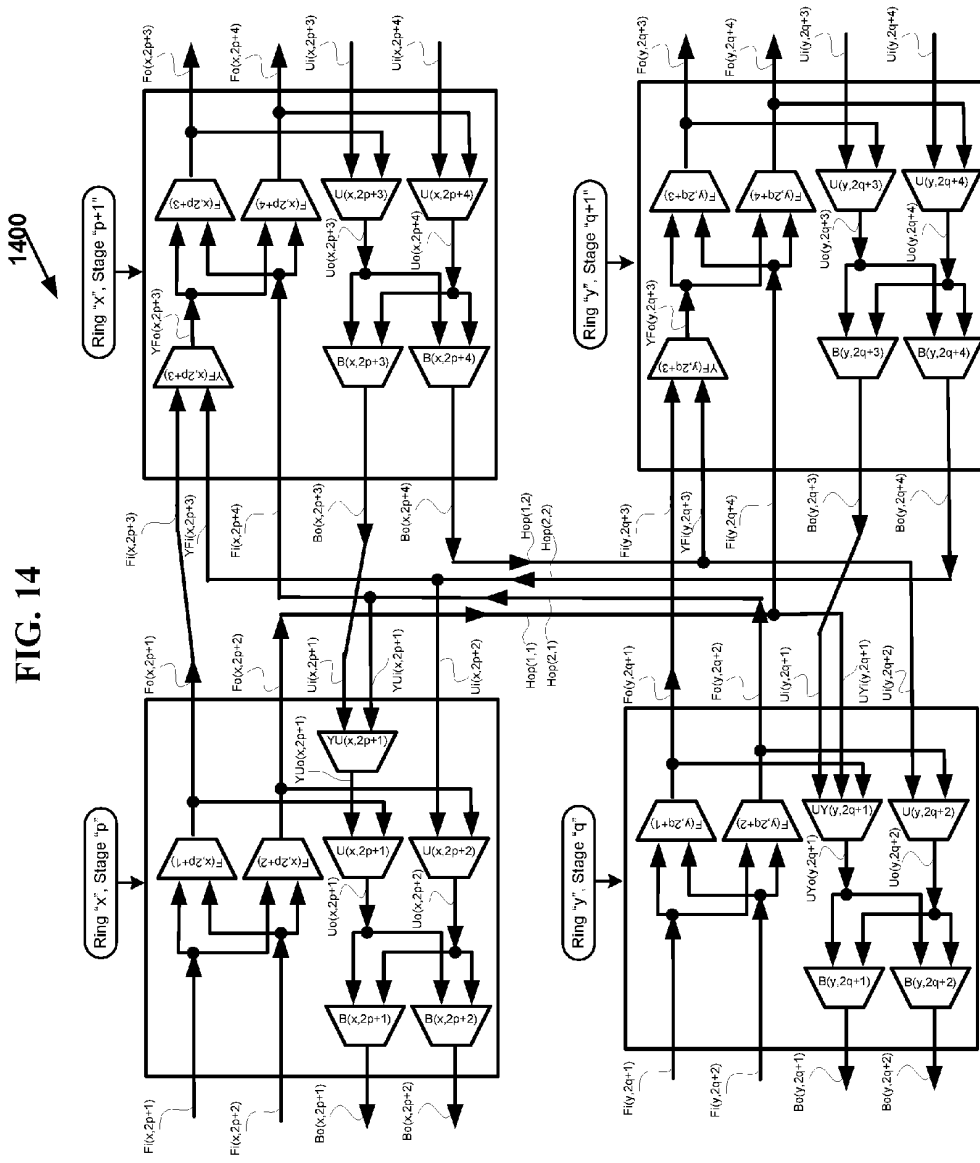
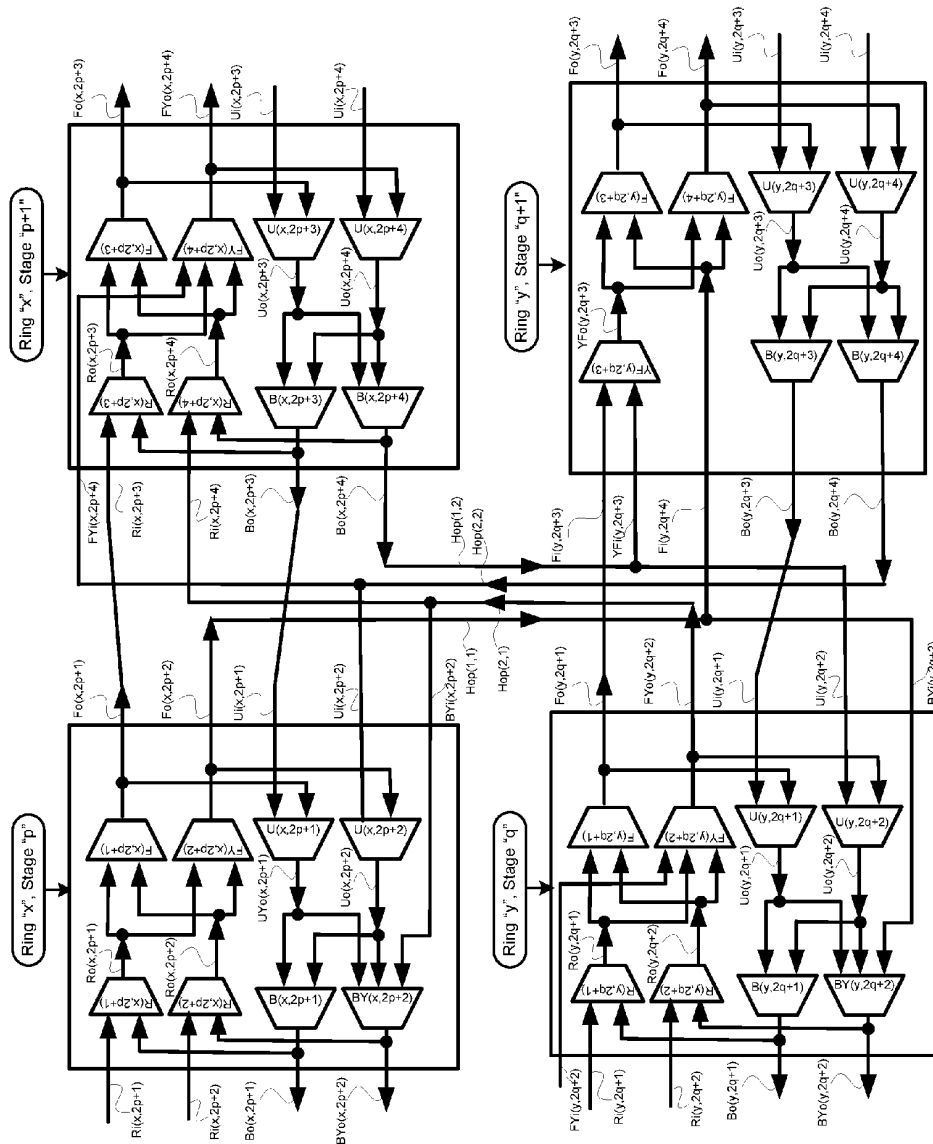

FIG. 14

1500

FIG. 15



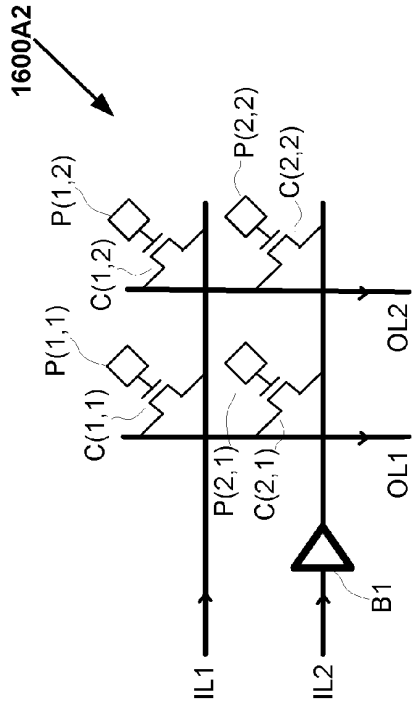

FIG. 16A2
(Prior Art)

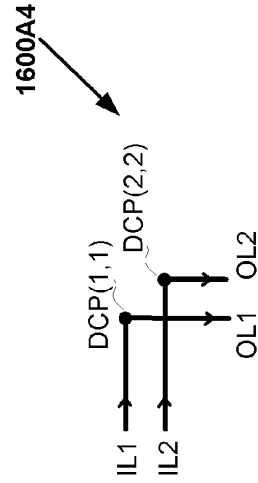

FIG. 16A4
(Prior Art)

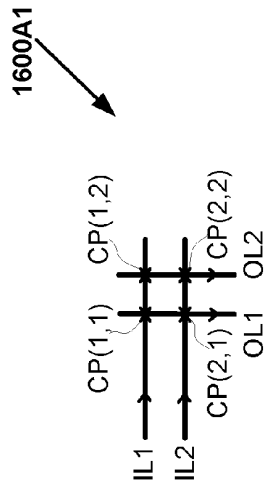

FIG. 16A1
(Prior Art)

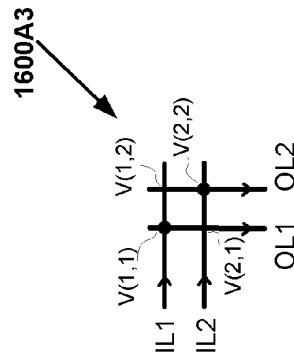

FIG. 16A3
(Prior Art)

1

**OPTIMIZATION OF MULTI-STAGE
HIERARCHICAL NETWORKS FOR
PRACTICAL ROUTING APPLICATIONS**

CROSS REFERENCE TO RELATED
APPLICATIONS

This is a Continuation Application and claims priority of U.S. patent application Ser. No. 14/199,168 entitled "OPTIMIZATION OF MULTI-STAGE HIERARCHICAL NETWORKS FOR PRACTICAL ROUTING APPLICATIONS" by Venkat Konda assigned to the same assignee as the current application and filed Mar. 6, 2014, which is incorporated by reference in its entirety. This application is related to and incorporates by reference in its entirety the PCT Application Serial No. PCT/US12/53814 entitled "OPTIMIZATION OF MULTI-STAGE HIERARCHICAL NETWORKS FOR PRACTICAL ROUTING APPLICATIONS" by Venkat Konda assigned to the same assignee as the current application, filed Sep. 6, 2012 and the U.S. Provisional Patent Application Ser. No. 61/531,615 entitled "OPTIMIZATION OF MULTI-STAGE HIERARCHICAL NETWORKS FOR PRACTICAL ROUTING APPLICATIONS" by Venkat Konda assigned to the same assignee as the current application, filed Sep. 7, 2011.

This application is related to and incorporates by reference in its entirety the U.S. Pat. No. 8,270,400 entitled "FULLY CONNECTED GENERALIZED MULTI-STAGE NETWORKS" by Venkat Konda assigned to the same assignee as the current application, issued Sep. 18, 2012, the PCT Application Serial No. PCT/U08/56064 entitled "FULLY CONNECTED GENERALIZED MULTI-STAGE NETWORKS" by Venkat Konda assigned to the same assignee as the current application, filed Mar. 6, 2008, the U.S. Provisional Patent Application Ser. No. 60/905,526 entitled "LARGE SCALE CROSSPOINT REDUCTION WITH NONBLOCKING UNICAST & MULTICAST IN ARBITRARILY LARGE MULTI-STAGE NETWORKS" by Venkat Konda assigned to the same assignee as the current application, filed Mar. 6, 2007, and the U.S. Provisional Patent Application Ser. No. 60/940,383 entitled "FULLY CONNECTED GENERALIZED MULTI-STAGE NETWORKS" by Venkat Konda assigned to the same assignee as the current application, filed May 25, 2007.

This application is related to and incorporates by reference in its entirety the U.S. Pat. No. 8,170,040 entitled "FULLY CONNECTED GENERALIZED BUTTERFLY FAT TREE NETWORKS" by Venkat Konda assigned to the same assignee as the current application, issued May 1, 2012, the PCT Application Serial No. PCT/U08/64603 entitled "FULLY CONNECTED GENERALIZED BUTTERFLY FAT TREE NETWORKS" by Venkat Konda assigned to the same assignee as the current application, filed May 22, 2008, the U.S. Provisional Patent Application Ser. No. 60/940,387 entitled "FULLY CONNECTED GENERALIZED BUTTERFLY FAT TREE NETWORKS" by Venkat Konda assigned to the same assignee as the current application, filed May 25, 2007, and the U.S. Provisional Patent Application Ser. No. 60/940,390 entitled "FULLY CONNECTED GENERALIZED MULTI-LINK BUTTERFLY FAT TREE NETWORKS" by Venkat Konda assigned to the same assignee as the current application, filed May 25, 2007.

This application is related to and incorporates by reference in its entirety the U.S. Pat. No. 8,363,649 entitled "FULLY CONNECTED GENERALIZED MULTI-LINK MULTI-STAGE NETWORKS" by Venkat Konda assigned

2

to the same assignee as the current application, issued Jan. 29, 2013, the PCT Application Serial No. PCT/U08/64604 entitled "FULLY CONNECTED GENERALIZED MULTI-LINK MULTI-STAGE NETWORKS" by Venkat Konda assigned to the same assignee as the current application, filed May 22, 2008, the U.S. Provisional Patent Application Ser. No. 60/940,389 entitled "FULLY CONNECTED GENERALIZED REARRANGEABLY NONBLOCKING MULTI-LINK MULTI-STAGE NETWORKS" by Venkat Konda assigned to the same assignee as the current application, filed May 25, 2007, the U.S. Provisional Patent Application Ser. No. 60/940,391 entitled "FULLY CONNECTED GENERALIZED FOLDED MULTI-STAGE NETWORKS" by Venkat Konda assigned to the same assignee as the current application, filed May 25, 2007 and the U.S. Provisional Patent Application Ser. No. 60/940,392 entitled "FULLY CONNECTED GENERALIZED STRICTLY NONBLOCKING MULTI-LINK MULTI-STAGE NETWORKS" by Venkat Konda assigned to the same assignee as the current application, filed May 25, 2007.

This application is related to and incorporates by reference in its entirety the U.S. Pat. No. 8,269,523 entitled "VLSI LAYOUTS OF FULLY CONNECTED GENERALIZED NETWORKS" by Venkat Konda assigned to the same assignee as the current application, issued Sep. 18, 2012, the PCT Application Serial No. PCT/U08/64605 entitled "VLSI LAYOUTS OF FULLY CONNECTED GENERALIZED NETWORKS" by Venkat Konda assigned to the same assignee as the current application, filed May 22, 2008, and the U.S. Provisional Patent Application Ser. No. 60/940,394 entitled "VLSI LAYOUTS OF FULLY CONNECTED GENERALIZED NETWORKS" by Venkat Konda assigned to the same assignee as the current application, filed May 25, 2007.

This application is related to and incorporates by reference in its entirety the U.S. Pat. No. 8,898,611 entitled "VLSI LAYOUTS OF FULLY CONNECTED GENERALIZED AND PYRAMID NETWORKS WITH LOCALITY EXPLOITATION" by Venkat Konda assigned to the same assignee as the current application, issued Nov. 25, 2014, the PCT Application Serial No. PCT/US10/52984 entitled "VLSI LAYOUTS OF FULLY CONNECTED GENERALIZED AND PYRAMID NETWORKS WITH LOCALITY EXPLOITATION" by Venkat Konda assigned to the same assignee as the current application, filed Oct. 16, 2010, the U.S. Provisional Patent Application Ser. No. 61/252,603 entitled "VLSI LAYOUTS OF FULLY CONNECTED NETWORKS WITH LOCALITY EXPLOITATION" by Venkat Konda assigned to the same assignee as the current application, filed Oct. 16, 2009, and the U.S. Provisional Patent application Ser. No. 61/252,609 entitled "VLSI LAYOUTS OF FULLY CONNECTED GENERALIZED AND PYRAMID NETWORKS" by Venkat Konda assigned to the same assignee as the current application, filed Oct. 16, 2009.

This application is related to and incorporates by reference in its entirety the U.S. application Ser. No. 14/329,876 entitled "FAST SCHEDULING AND OPTIMIZATION OF MULTI-STAGE HIERARCHICAL NETWORKS" by Venkat Konda assigned to the same assignee as the current application, filed Jul. 11, 2014 and the U.S. Provisional Patent Application Ser. No. 61/846,083 entitled "FAST SCHEDULING AND OPTIMIZATION OF MULTI-STAGE HIERARCHICAL NETWORKS" by Venkat Konda assigned to the same assignee as the current application, filed Jul. 15, 2013.

BACKGROUND OF INVENTION

Multi-stage interconnection networks such as Benes networks and butterfly fat tree networks are widely useful in

telecommunications, parallel and distributed computing. However VLSI layouts, known in the prior art, of these interconnection networks in an integrated circuit are inefficient and complicated.

Other multi-stage interconnection networks including butterfly fat tree networks, Banyan networks, Batchner-Banyan networks, Baseline networks, Delta networks, Omega networks and Flip networks have been widely studied particularly for self-routing packet switching applications. Also Benes Networks with radix of two have been widely studied and it is known that Benes Networks of radix two are shown to be built with back to back baseline networks which are rearrangeably nonblocking for unicast connections.

The most commonly used VLSI layout in an integrated circuit is based on a two-dimensional grid model comprising only horizontal and vertical tracks. An intuitive interconnection network that utilizes two-dimensional grid model is 2D Mesh Network and its variations such as segmented mesh networks. Hence routing networks used in VLSI layouts are typically 2D mesh networks and its variations. However Mesh Networks require large scale cross points typically with a growth rate of $O(N^2)$ where N is the number of computing elements, ports, or logic elements depending on the application.

Multi-stage interconnection network with a growth rate of $O(N \times \log N)$ requires significantly small number of cross points. U.S. Pat. No. 6,185,220 entitled "Grid Layouts of Switching and Sorting Networks" granted to Muthukrishnan et al. describes a VLSI layout using existing VLSI grid model for Benes and Butterfly networks. U.S. Pat. No. 6,940,308 entitled "Interconnection Network for a Field Programmable Gate Array" granted to Wong describes a VLSI layout where switches belonging to lower stage of Benes Network are laid out close to the logic cells and switches belonging to higher stages are laid out towards the center of the layout.

Due to the inefficient and in some cases impractical VLSI layout of Benes and butterfly fat tree networks on a semiconductor chip, today mesh networks and segmented mesh networks are widely used in the practical applications such as field programmable gate arrays (FPGAs), programmable logic devices (PLDs), and parallel computing interconnects. The prior art VLSI layouts of Benes and butterfly fat tree networks and VLSI layouts of mesh networks and segmented mesh networks require large area to implement the switches on the chip, large number of wires, longer wires, with increased power consumption, increased latency of the signals which effect the maximum clock speed of operation. Some networks may not even be implemented practically on a chip due to the lack of efficient layouts.

Fully connected Benes and butterfly fat tree networks are an over kill for certain practical routing applications and need to be optimized to significantly improve area, power and performance of the routing network.

SUMMARY OF INVENTION

Significantly optimized multi-stage networks, useful in wide target applications, with VLSI layouts (or floor plans) using only horizontal and vertical links to route large scale sub-integrated circuit blocks having inlet and outlet links, and laid out in an integrated circuit device in a two-dimensional grid arrangement of blocks, (for example in an FPGA where the sub-integrated circuit blocks are Lookup Tables, or memory blocks, or DSP blocks) are presented. The optimized multi-stage networks in each block employ several rings of stages of switches with inlet and outlet links

of sub-integrated circuit blocks connecting to rings from either left-hand side only, or from right-hand side only, or from both left-hand side and right-hand side.

The optimized multi-stage networks with their VLSI layouts employ shuffle exchange links where outlet links of cross links from switches in a stage of a ring in one sub-integrated circuit block are connected to either inlet links of switches in the another stage of a ring in another sub-integrated circuit block or inlet links of switches in the another stage of a ring in the same sub-integrated circuit block so that said cross links are either vertical links or horizontal and vice versa.

The VLSI layouts exploit spatial locality so that different sub-integrated circuit blocks that are spatially nearer are connected with shorter shuffle exchange links compared to the shuffle exchange links between spatially farther sub-integrated circuit blocks. The optimized multi-stage networks provide high routability for broadcast, unicast and multicast connections, yet with the benefits of significantly lower cross points hence smaller area, lower signal latency, lower power and with significant fast compilation or routing time.

The optimized multi-stage networks $V_{Comb}(N_1, N_2, d, s)$ & $V_{D-Comb}(N_1, N_2, d, s)$ according to the current invention inherit the properties of one or more, in addition to additional properties, generalized multi-stage and pyramid networks $V(N_1, N_2, d, s)$ & $V_p(N_1, N_2, d, s)$, generalized folded multi-stage and pyramid networks $V_{fold}(N_1, N_2, d, s)$ & $V_{fold-p}(N_1, N_2, d, s)$, generalized butterfly fat tree and butterfly fat pyramid networks $V_{bft}(N_1, N_2, d, s)$ & $V_{bfp}(N_1, N_2, d, s)$, generalized multi-link multi-stage and pyramid networks $V_{mlink}(N_1, N_2, d, s)$ & $V_{mlink-p}(N_1, N_2, d, s)$, generalized folded multi-link multi-stage and pyramid networks $V_{fold-mlink}(N_1, N_2, d, s)$ & $V_{fold-mlink-p}(N_1, N_2, d, s)$, generalized multi-link butterfly fat tree and butterfly fat pyramid networks $V_{mlink-bft}(N_1, N_2, d, s)$ & $V_{mlink-bfp}(N_1, N_2, d, s)$, generalized hypercube networks $V_{hcube}(N_1, N_2, d, s)$, and generalized cube connected cycles networks $V_{CCC}(N_1, N_2, d, s)$ for $s=1, 2, 3$ or any number in general.

BRIEF DESCRIPTION OF DRAWINGS

FIG. 1A is a diagram 100A of an exemplary partial multi-stage hierarchical network corresponding to one block with 4 inputs and 2 outputs of a computational block connecting only from left-hand side, to route practical applications such as FPGA routing of hardware designs in accordance with the invention.

FIG. 1B is a diagram 100B of an exemplary partial multi-stage hierarchical network corresponding to one block with 8 inputs and 4 outputs of a computational block connecting from both left-hand side and right-hand side, to route practical applications such as FPGA routing of hardware designs in accordance with the invention.

FIG. 2A is a diagram 200A, in an embodiment of, a stage in a ring of multi-stage hierarchical network corresponding to one block.

FIG. 2B is a diagram 200B, in an embodiment of, a stage in a ring of multi-stage hierarchical network corresponding to one block.

FIG. 2C is a diagram 200C, in an embodiment of, a stage in a ring of multi-stage hierarchical network corresponding to one block.

FIG. 2D is a diagram 200D, in an embodiment of, a stage in a ring of multi-stage hierarchical network corresponding to one block.

5

FIG. 2E is a diagram 200E, in an embodiment of, a stage in a ring of multi-stage hierarchical network corresponding to one block.

FIG. 3A is a diagram 300A, in an embodiment of, all the connections between two successive stages of two different rings in the same block or in two different blocks of a multi-stage hierarchical network.

FIG. 3B is a diagram 300B, in an embodiment of, all the connections between two successive stages of two different rings in the same block or in two different blocks of a multi-stage hierarchical network.

FIG. 4 is a diagram 400, in an embodiment of, all the connections between two successive stages of two different rings in the same block or in two different blocks of a multi-stage hierarchical network.

FIG. 5 is a diagram 500, in an embodiment of, all the connections between two successive stages of two different rings in the same block or in two different blocks of a multi-stage hierarchical network.

FIG. 6 is a diagram 600, in an embodiment of, all the connections between two successive stages of two different rings in the same block or in two different blocks of a multi-stage hierarchical network.

FIG. 7 is a diagram 700, in an embodiment of hop wire connection chart corresponding to a block of multi-stage hierarchical network.

FIG. 8 is a diagram 800, in an embodiment of 2D-grid of blocks with each block corresponding to a partial multi-stage network to implement an exemplary multi-stage hierarchical network, in accordance with the invention.

FIG. 9A is a diagram 900A, in an embodiment of, a stage in a ring of multi-stage hierarchical network corresponding to one block, with delay optimizations.

FIG. 9B is a diagram 900B, in an embodiment of, a stage in a ring of multi-stage hierarchical network corresponding to one block, with delay optimizations.

FIG. 9C is a diagram 900C, in an embodiment of, a stage in a ring of multi-stage hierarchical network corresponding to one block, with delay optimizations.

FIG. 9D is a diagram 900D, in an embodiment of, a stage in a ring of multi-stage hierarchical network corresponding to one block, with delay optimizations.

FIG. 9E is a diagram 900E, in an embodiment of, a stage in a ring of multi-stage hierarchical network corresponding to one block, with delay optimizations.

FIG. 10A is a diagram 1000A, in an embodiment of, a stage in a ring of multi-stage hierarchical network corresponding to one block, with delay optimizations.

FIG. 10B is a diagram 1000B, in an embodiment of, a stage in a ring of multi-stage hierarchical network corresponding to one block, with delay optimizations.

FIG. 10C is a diagram 1000C, in an embodiment of, a stage in a ring of multi-stage hierarchical network corresponding to one block, with delay optimizations.

FIG. 10D is a diagram 1000D, in an embodiment of, a stage in a ring of multi-stage hierarchical network corresponding to one block, with delay optimizations.

FIG. 10E is a diagram 1000E, in an embodiment of, a stage in a ring of multi-stage hierarchical network corresponding to one block, with delay optimizations.

FIG. 10F is a diagram 1000F, in an embodiment of, a stage in a ring of multi-stage hierarchical network corresponding to one block, with delay optimizations.

FIG. 11A is a diagram 1100A, in an embodiment of, a stage in a ring of multi-stage hierarchical network corresponding to one block, with delay optimizations.

6

FIG. 11B is a diagram 1100B, in an embodiment of, a stage in a ring of multi-stage hierarchical network corresponding to one block, with delay optimizations.

FIG. 11C is a diagram 1100C, in an embodiment of, a stage in a ring of multi-stage hierarchical network corresponding to one block, with delay optimizations.

FIG. 12 is a diagram 1200, in an embodiment, all the connections between two successive stages of two different rings in the same block or in two different blocks of a multi-stage hierarchical network with delay optimizations.

FIG. 13 is a diagram 1300, in one embodiment, all the connections between two successive stages of two different rings in the same block or in two different blocks of a multi-stage hierarchical network with delay optimizations.

FIG. 14 is a diagram 1400, in an embodiment of, all the connections between two successive stages of two different rings in the same block or in two different blocks of a multi-stage hierarchical network with delay optimizations.

FIG. 15 is a diagram 1500, in an embodiment of, all the connections between two successive stages of two different rings in the same block or in two different blocks of a multi-stage hierarchical network with delay optimizations.

FIG. 16A1 is a diagram 1600A1 of an exemplary prior art implementation of a two by two switch; FIG. 16A2 is a diagram 1600A2 for programmable integrated circuit prior art implementation of the diagram 1600A1 of FIG. 16A1; FIG. 16A3 is a diagram 1600A3 for one-time programmable integrated circuit prior art implementation of the diagram 1600A1 of FIG. 16A1; FIG. 16A4 is a diagram 1600A4 for integrated circuit placement and route implementation of the diagram 1600A1 of FIG. 16A1.

DETAILED DESCRIPTION OF THE INVENTION

Fully connected multi-stage hierarchical networks are an over kill in every dimension such as area, power, and performance for certain practical routing applications and need to be optimized to significantly improve savings in area, power and performance of the routing network. The present invention discloses several embodiments of the optimized multi-stage hierarchical networks for practical routing applications along with their VLSI layout (floor plan) feasibility and simplicity.

The multi-stage hierarchical networks considered for optimization in the current invention include: generalized multi-stage networks $V(N_1, N_2, d, s)$, generalized folded multi-stage networks $V_{fold}(N_1, N_2, d, s)$, generalized butterfly fat tree networks $V_{bft}(N_1, N_2, d, s)$, generalized multi-link multi-stage networks $V_{mlink}(N_1, N_2, d, s)$, generalized folded multi-link multi-stage networks $V_{fold-mlink}(N_1, N_2, d, s)$, generalized multi-link butterfly fat tree networks $V_{mlink-bft}(N_1, N_2, d, s)$, generalized hypercube networks $V_{hcube}(N_1, N_2, d, s)$, and generalized cube connected cycles networks $V_{ccc}(N_1, N_2, d, s)$ for $s=1,2,3$ or any number in general. Alternatively the optimized multi-stage hierarchical networks disclosed in this invention inherit the properties of one or more of these networks, in addition to additional properties that may not be exhibited these networks.

The optimized multi-stage hierarchical networks disclosed are applicable for practical routing applications, with several goals such as: 1) all the signals in the design starting from an inlet link of the network to an outlet link of the network need to be setup without blocking. These signals may consist of broadcast, unicast and multicast connections; Each routing resource may need to be used by only one signal or connection; 2) physical area consumed by the

routing network to setup all the signals needs to be small; 3) power consumption of the network needs to be small, after the signals are setup. Power may be both static power and dynamic power; 4) Delay of the signal or a connection needs to be small after it is setup through a path using several routing resources in the path. The smaller the delay of the connections will lead to faster performance of the design. Typically delay of the critical connections determines the performance of the design on a given network; 5) Designs need to be not only routed through the network (i.e., all the signals need to be setup from inlet links of the network to the outlet links of the network.), but also the routing needs to be in faster time using efficient routing algorithms; 6) Efficient VLSI layout of the network is also critical and can greatly influence all the other parameters including the area taken up by the network on the chip, total number of wires, length of the wires, delay through the signal paths and hence the maximum clock speed of operation.

The different varieties of multi-stage networks described in various embodiments in the current invention have not been implemented previously on the semiconductor chips. The practical application of these networks includes Field Programmable Gate Array (FPGA) chips. Current commercial FPGA products such as Xilinx's Vertex, Altera's Stratix, Lattice's ECPx implement island-style architecture using mesh and segmented mesh routing interconnects using either full crossbars or sparse crossbars. These routing interconnects consume large silicon area for crosspoints, long wires, large signal propagation delay and hence consume lot of power.

The current invention discloses the optimization of multi-stage hierarchical networks for practical routing applications of numerous types of multi-stage networks. The optimizations disclosed in the current invention are applicable to including the numerous generalized multi-stage networks disclosed in the following patent applications:

1) Strictly and rearrangeably nonblocking for arbitrary fan-out multicast and unicast for generalized multi-stage networks $V(N_1, N_2, d, s)$ with numerous connection topologies and the scheduling methods are described in detail in the U.S. Pat. No. 8,270,400 that is incorporated by reference above.

2) Strictly and rearrangeably nonblocking for arbitrary fan-out multicast and unicast for generalized butterfly fat tree networks $V_{bft}(N_1, N_2, d, s)$ with numerous connection topologies and the scheduling methods are described in detail in the U.S. Pat. No. 8,170,040 that is incorporated by reference above.

3) Rearrangeably nonblocking for arbitrary fan-out multicast and unicast, and strictly nonblocking for unicast for generalized multi-link multi-stage networks $V_{mlink}(N_1, N_2, d, s)$ and generalized folded multi-link multi-stage networks $V_{fold-mlink}(N_1, N_2, d, s)$ with numerous connection topologies and the scheduling methods are described in detail in the U.S. Pat. No. 8,363,649 that is incorporated by reference above.

4) Strictly and rearrangeably nonblocking for arbitrary fan-out multicast and unicast for generalized multi-link butterfly fat tree networks $V_{mlink-bft}(N_1, N_2, d, s)$ with numerous connection topologies and the scheduling methods are described in detail in the U.S. Pat. No. 8,170,040 that is incorporated by reference above.

5) Strictly and rearrangeably nonblocking for arbitrary fan-out multicast and unicast for generalized folded multi-stage networks $V_{fold}(N_1, N_2, d, s)$ with numerous connection

topologies and the scheduling methods are described in detail in the U.S. Pat. No. 8,363,649 that is incorporated by reference above.

6) Strictly nonblocking for arbitrary fan-out multicast and unicast for generalized multi-link multi-stage networks $V_{mlink}(N_1, N_2, d, s)$ and generalized folded multi-link multi-stage networks $V_{fold-mlink}(N_1, N_2, d, s)$ with numerous connection topologies and the scheduling methods are described in detail in the U.S. Pat. No. 8,363,649 that is incorporated by reference above.

7) VLSI layouts of numerous types of multi-stage networks are described in the U.S. Pat. No. 8,269,523 entitled "VLSI LAYOUTS OF FULLY CONNECTED NETWORKS" that is incorporated by reference above.

8) VLSI layouts of numerous types of multi-stage networks are described in the U.S. Pat. No. 8,898,611 entitled "VLSI LAYOUTS OF FULLY CONNECTED GENERALIZED AND PYRAMID NETWORKS WITH LOCALITY EXPLOITATION" that is incorporated by reference above.

In addition the optimization with the VLSI layouts disclosed in the current invention are also applicable to generalized multi-stage pyramid networks $V_p(N_1, N_2, d, s)$, generalized folded multi-stage pyramid networks $V_{fold-p}(N_1, N_2, d, s)$, generalized butterfly fat pyramid networks $V_{bfp}(N_1, N_2, d, s)$, generalized multi-link multi-stage pyramid networks $V_{mlink-p}(N_1, N_2, d, s)$, generalized folded multi-link multi-stage pyramid networks $V_{fold-mlink-p}(N_1, N_2, d, s)$, generalized multi-link butterfly fat pyramid networks $V_{mlink-bfp}(N_1, N_2, d, s)$, generalized hypercube networks $V_{hcube}(N_1, N_2, d, s)$ and generalized cube connected cycles networks $V_{CCC}(N_1, N_2, s)$ for $s=1, 2, 3$ or any number in general.

Finally the current invention discloses the optimizations and VLSI layouts of multi-stage hierarchical networks $V_{Comb}(N_1, N_2, d, s)$ and the optimizations and VLSI layouts of multi-stage hierarchical networks $V_{D-Comb}(N_1, N_2, d, s)$ for practical routing applications (particularly to set up broadcast, unicast and multicast connections), where "Comb" denotes the combination of and "D-Comb" denotes the delay optimized combination of any of the generalized multi-stage networks $V(N_1, N_2, d, s)$, generalized folded multi-stage networks $V_{fold}(N_1, N_2, d, s)$, generalized butterfly fat tree networks $V_{bft}(N_1, N_2, d, s)$, generalized multi-link multi-stage networks $V_{mlink}(N_1, N_2, d, s)$, generalized folded multi-link multi-stage networks $V_{fold-mlink}(N_1, N_2, d, s)$, generalized multi-link butterfly fat tree networks $V_{mlink-bft}(N_1, N_2, d, s)$, generalized multi-stage pyramid networks $V_p(N_1, N_2, d, s)$, generalized folded multi-stage pyramid networks $V_{fold-p}(N_1, N_2, d, s)$, generalized butterfly fat pyramid networks $V_{bfp}(N_1, N_2, d, s)$, generalized multi-link multi-stage pyramid networks $V_{mlink-p}(N_1, N_2, d, s)$, generalized folded multi-link multi-stage pyramid networks $V_{fold-mlink-p}(N_1, N_2, d, s)$, generalized multi-link butterfly fat pyramid networks $V_{mlink-bfp}(N_1, N_2, d, s)$, generalized hypercube networks $V_{hcube}(N_1, N_2, d, s)$, and generalized cube connected cycles networks $V_{CCC}(N_1, N_2, d, s)$ for $s=1, 2, 3$ or any number in general.

Multi-Stage Hierarchical Network $V_{Comb}(N_1, N_2, d, s)$:

Referring to diagram 100A in FIG. 1A, in one embodiment, an exemplary partial multi-stage hierarchical network $V_{Comb}(N_1, N_2, d, s)$ where $N_1=200$; $N_2=400$; $d=2$; and $s=1$ corresponding to one computational block, with each computational block having 4 inlet links namely I1, I2, I3, and I4; and 2 outlet links namely O1 and O2. And for each computational block the corresponding partial multi-stage hierarchical network $V_{Comb}(N_1, N_2, d, s)$ 100A consists of two rings 110 and 120, where ring 110 consists of "m+1" stages namely (ring 1, stage 0), (ring 1, stage 1), . . . (ring 1, stage "m-1"), and (ring 1, stage "m"), and ring 120 consists of

“n+1” stages namely (ring 2, stage 0), (ring 2, stage 1), . . . (ring 2, stage “n-1”), and (ring 2, stage “n”), where “m” and “n” are positive integers.

Ring **110** has inlet links $Ri(1,1)$ and $Ri(1,2)$, and has outlet links $Bo(1,1)$ and $Bo(1,2)$. Ring **120** has inlet links $Fi(2,1)$ and $Fi(2,2)$, and outlet links $Bo(2,1)$ and $Bo(2,2)$. And hence the partial multi-stage hierarchical network $V_{Comb}(N_1, N_2, d, s)$ **100A** consists of 4 inlet links and 4 outlet links corresponding to the two rings **110** and **120**. Outlet link **O1** of the computational block is connected to inlet link $Ri(1,1)$ of ring **110** and also inlet link of $Fi(2,1)$ of ring **120**. Similarly outlet link **O2** of the computational block is connected to inlet link $Ri(1,2)$ of Ring **110** and also inlet link of $Fi(2,2)$ of Ring **120**. And outlet link $Bo(1,1)$ of Ring **110** is connected to inlet link **I1** of the computational block. Outlet link $Bo(1,2)$ of Ring **110** is connected to inlet link **I2** of the computational block. Similarly outlet link $Bo(2,1)$ of Ring **120** is connected to inlet link **I3** of the computational block. Outlet link $Bo(2,2)$ of Ring **120** is connected to inlet link **I4** of the computational block. Since in this embodiment outlet link **O1** of the computational block is connected to both inlet link $Ri(1,1)$ of ring **110** and inlet link $Fi(2,1)$ of ring **120**; and outlet link **O2** of the computational block is connected to both inlet link $Ri(1,2)$ of ring **110** and inlet link $Fi(2,2)$ of ring **120**, the partial multi-stage hierarchical network $V_{Comb}(N_1, N_2, d, s)$ **100A** consists of 2 inlet links and 4 outlet links.

The two dimensional grid **800** in FIG. **8** illustrates an exemplary arrangement of 100 blocks arranged in 10 rows and 10 columns, in an embodiment. Each row of 2D-grid consisting of 10 block numbers namely the first row consists of the blocks (1,1), (1,2), (1,3), . . . , (1,9), and (1,10). The second row consists of the blocks (2,1), (2,2), (2,3), . . . , (2,9), and (2,10). Similarly 2D-grid **800** consists of 10 rows of each with 10 blocks and finally the tenth row consists of the blocks (10,1), (10,2), (10,3), . . . , (10,9), and (10,10). Each block of 2D-grid **800**, in one embodiment, is part of the die area of a semiconductor integrated circuit, so that the complete 2D-grid **800** of 100 blocks represents the complete die of the semiconductor integrated circuit. In one embodiment, each block of 2D-grid **800** consists of one of the partial multi-stage hierarchical network $V_{Comb}(N_1, N_2, d, s)$ **100A** with 2 inlet links and 4 outlet links and the corresponding computational block with 4 inlet links and 2 outlet links. For example block (1,1) of 2D-grid **800** consists of one of the partial multi-stage hierarchical network $V_{Comb}(N_1, N_2, d, s)$ **100A** with 2 inlet links and 4 outlet links and the corresponding computational block with 4 Inlet links and 2 outlet links. Similarly each of the 100 blocks of 2D-grid **800** has a separate partial multi-stage hierarchical network $V_{Comb}(N_1, N_2, d, s)$ **100A** with 2 inlet links and 4 outlet links and the corresponding computational block with 4 inlet links and 2 outlet links. Hence the complete multi-stage hierarchical network $V_{Comb}(N_1, N_2, d, s)$ corresponding to 2D-grid **800** has $N_1=200$ inlet links and $N_2=400$ outlet links. And there are 100 computational blocks each one corresponding to one of the blocks with each computational block having 4 inlet links and 2 outlet links. Also the 2D-grid **800** is organized in the fourth quadrant of the 2D-Plane. In other embodiments the 2D-grid **800** may be organized as either first quadrant, or second quadrant or third quadrant of the 2D-Plane.

Referring to partial multi-stage hierarchical network $V_{Comb}(N_1, N_2, d, s)$ **100A** in FIG. **1A**, the stage (ring 1, stage 0) consists of 4 inputs namely $Ri(1,1)$, $Ri(1,2)$, $Ui(1,1)$, and $Ui(1,2)$; and 4 outputs $Bo(1,1)$, $Bo(1,2)$, $Fo(1,1)$, and $Fo(1,2)$. The stage (ring 1, stage 0) also consists of eight 2:1 multiplexers (A multiplexer is hereinafter called a “mux”)

namely $R(1,1)$, $R(1,2)$, $F(1,1)$, $F(1,2)$, $U(1,1)$, $U(1,2)$, $B(1,1)$, and $B(1,2)$. The 2:1 Mux $R(1,1)$ has two inputs namely $Ri(1,1)$ and $Bo(1,1)$ and has one output $Ro(1,1)$. The 2:1 Mux $R(1,2)$ has two inputs namely $Ri(1,2)$ and $Bo(1,2)$ and has one output $Ro(1,2)$. The 2:1 Mux $F(1,1)$ has two inputs namely $Ro(1,1)$ and $Ro(1,2)$ and has one output $Fo(1,1)$. The 2:1 Mux $F(1,2)$ has two inputs namely $Ro(1,1)$ and $Ro(1,2)$ and has one output $Fo(1,2)$.

The 2:1 Mux $U(1,1)$ has two inputs namely $Ui(1,1)$ and $Fo(1,1)$ and has one output $Uo(1,1)$. The 2:1 Mux $U(1,2)$ has two inputs namely $Ui(1,2)$ and $Fo(1,2)$ and has one output $Uo(1,2)$. The 2:1 Mux $B(1,1)$ has two inputs namely $Uo(1,1)$ and $Uo(1,2)$ and has one output $Bo(1,1)$. The 2:1 Mux $B(1,2)$ has two inputs namely $Uo(1,1)$ and $Uo(1,2)$ and has one output $Bo(1,2)$.

The stage (ring 1, stage 1) consists of 4 inputs namely $Ri(1,3)$, $Ri(1,4)$, $Ui(1,3)$, and $Ui(1,4)$; and 4 outputs $Bo(1,3)$, $Bo(1,4)$, $Fo(1,3)$, and $Fo(1,4)$. The stage (ring 1, stage 1) also consists of eight 2:1 Muxes namely $R(1,3)$, $R(1,4)$, $F(1,3)$, $F(1,4)$, $U(1,3)$, $U(1,4)$, $B(1,3)$, and $B(1,4)$. The 2:1 Mux $R(1,3)$ has two inputs namely $Ri(1,3)$ and $Bo(1,3)$ and has one output $Ro(1,3)$. The 2:1 Mux $R(1,4)$ has two inputs namely $Ri(1,4)$ and $Bo(1,4)$ and has one output $Ro(1,4)$. The 2:1 Mux $F(1,3)$ has two inputs namely $Ro(1,3)$ and $Ro(1,4)$ and has one output $Fo(1,3)$. The 2:1 Mux $F(1,4)$ has two inputs namely $Ro(1,3)$ and $Ro(1,4)$ and has one output $Fo(1,4)$.

The 2:1 Mux $U(1,3)$ has two inputs namely $Ui(1,3)$ and $Fo(1,3)$ and has one output $Uo(1,3)$. The 2:1 Mux $U(1,4)$ has two inputs namely $Ui(1,4)$ and $Fo(1,4)$ and has one output $Uo(1,4)$. The 2:1 Mux $B(1,3)$ has two inputs namely $Uo(1,3)$ and $Uo(1,4)$ and has one output $Bo(1,3)$. The 2:1 Mux $B(1,4)$ has two inputs namely $Uo(1,3)$ and $Uo(1,4)$ and has one output $Bo(1,4)$.

The output $Fo(1,1)$ of the stage (ring 1, stage 0) is connected to the input $Ri(1,3)$ of the stage (ring 1, stage 1) which is called hereinafter an internal connection between two successive stages of a ring. And the output $Bo(1,3)$ of the stage (ring 1, stage 1) is connected to the input $Ui(1,1)$ of the stage (ring 1, stage 0), is another internal connection between stage 0 and stage 1 of the ring 1.

The stage (ring 1, stage “m-1”) consists of 4 inputs namely $Fi(1,2m-1)$, $Fi(1,2m)$, $Ui(1,2m-1)$, and $Ui(1,2m)$; and 4 outputs $Bo(1,2m-1)$, $Bo(1,2m)$, $Fo(1,2m-1)$, and $Fo(1,2m)$. The stage (ring 1, stage “m-1”) also consists of six 2:1 Muxes namely $F(1,2m-1)$, $F(1,2m)$, $U(1,2m-1)$, $U(1,2m)$, $B(1,2m-1)$, and $B(1,2m)$. The 2:1 Mux $F(1,2m-1)$ has two inputs namely $Fi(1,2m-1)$ and $Fi(1,2m)$ and has one output $Fo(1,2m-1)$. The 2:1 Mux $F(1,2m)$ has two inputs namely $Fi(1,2m-1)$ and $Fi(1,2m)$ and has one output $Fo(1,2m)$.

The 2:1 Mux $U(1,2m-1)$ has two inputs namely $Ui(1,2m-1)$ and $Fo(1,2m-1)$ and has one output $Uo(1,2m-1)$. The 2:1 Mux $U(1,2m)$ has two inputs namely $Ui(1,2m)$ and $Fo(1,2m)$ and has one output $Uo(1,2m)$. The 2:1 Mux $B(1,2m-1)$ has two inputs namely $Uo(1,2m-1)$ and $Uo(1,2m)$ and has one output $Bo(1,2m-1)$. The 2:1 Mux $B(1,2m)$ has two inputs namely $Uo(1,2m-1)$ and $Uo(1,2m)$ and has one output $Bo(1,2m)$.

The stage (ring 1, stage “m”) consists of 4 inputs namely $Fi(1,2m+1)$, $Fi(1,2m+2)$, $Ui(1,2m+1)$, and $Ui(1,2m+2)$; and 4 outputs $Bo(1,2m+1)$, $Bo(1,2m+2)$, $Fo(1,2m+1)$, and $Fo(1,2m+2)$. The stage (ring 1, stage “m”) also consists of six 2:1 Muxes namely $F(1,2m+1)$, $F(1,2m+2)$, $U(1,2m+1)$, $U(1,2m+2)$, $B(1,2m+1)$, and $B(1,2m+2)$. The 2:1 Mux $F(1,2m+1)$ has two inputs namely $Fi(1,2m+1)$ and $Fi(1,2m+2)$ and

has one output $Fo(1,2m+1)$. The 2:1 Mux $F(1,2m+2)$ has two inputs namely $Fi(1,2m+1)$ and $Fi(1,2m+2)$ and has one output $Fo(1,2m+2)$.

The 2:1 Mux $U(1,2m+1)$ has two inputs namely $Ui(1,2m+1)$ and $Fo(1,2m+1)$ and has one output $Uo(1,2m+1)$. The 2:1 Mux $U(1,2m+2)$ has two inputs namely $Ui(1,2m+2)$ and $Fo(1,2m+2)$ and has one output $Uo(1,2m+2)$. The 2:1 Mux $B(1,2m+1)$ has two inputs namely $Uo(1,2m+1)$ and $Uo(1,2m+2)$ and has one output $Bo(1,2m+1)$. The 2:1 Mux $B(1,2m+2)$ has two inputs namely $Uo(1,2m+1)$ and $Uo(1,2m+2)$ and has one output $Bo(1,2m+2)$.

The output $Fo(1,2m-1)$ of the stage (ring 1, stage “m-1”) is connected to the input $Fi(1,2m+1)$ of the stage (ring 1, stage “m”), is an internal connection between stage “m-1” and stage “m” of the ring 1. And the output $Bo(1,2m+1)$ of the stage (ring 1, stage “m”) is connected to the input $Ui(1,2m-1)$ of the stage (ring 1, stage “m-1”), is another internal connection between stage “m-1” and stage “m” of the ring 1.

Just the same way the stages (ring 1, stage 0), (ring 1, stage 1), there are also stages (ring 1, stage 2), (ring 1, stage 3), . . . (ring 1, stage “m-1”), (ring 1, stage “m”) in that order, where the stages from (ring 1, stage 2), (ring 1, stage 3), . . . , (ring 1, stage “m-2”) are not shown in the diagram 100A. Just the same way the two successive stages (ring 1, stage 0) and (ring 1, stage 1) have internal connections between them as described before, any two successive stages have similar internal connections. For example (ring 1, stage 1) and (ring 1, stage 2) have similar internal connections and (ring 1, stage “m-2”) and (ring 1, stage “m-1”) have similar internal connections.

Stage (ring 1, stage 0) is also called hereinafter the “entry stage” or “first stage” of ring 1, since inlet links and outlet links of the computational block are directly connected to stage (ring 1, stage 0). Also stage (ring 1, stage “m”) is hereinafter the “last stage” or “root stage” of ring 1.

The stage (ring 2, stage 0) consists of 4 inputs namely $Fi(2,1)$, $Fi(2,2)$, $Ui(2,1)$, and $Ui(2,2)$; and 4 outputs $Bo(2,1)$, $Bo(2,2)$, $Fo(2,1)$, and $Fo(2,2)$. The stage (ring 2, stage 0) also consists of six 2:1 Muxes namely $F(2,1)$, $F(2,2)$, $U(2,1)$, $U(2,2)$, $B(2,1)$, and $B(2,2)$. The 2:1 Mux $F(2,1)$ has two inputs namely $Fi(2,1)$ and $Fi(2,2)$ and has one output $Fo(2,1)$. The 2:1 Mux $F(2,2)$ has two inputs namely $Fi(2,1)$ and $Fi(2,2)$ and has one output $Fo(2,2)$.

The 2:1 Mux $U(2,1)$ has two inputs namely $Ui(2,1)$ and $Fo(2,1)$ and has one output $Uo(2,1)$. The 2:1 Mux $U(2,2)$ has two inputs namely $Ui(2,2)$ and $Fo(2,2)$ and has one output $Uo(2,2)$. The 2:1 Mux $B(2,1)$ has two inputs namely $Uo(2,1)$ and $Uo(2,2)$ and has one output $Bo(2,1)$. The 2:1 Mux $B(2,2)$ has two inputs namely $Uo(2,1)$ and $Uo(2,2)$ and has one output $Bo(2,2)$.

The stage (ring 2, stage 1) consists of 4 inputs namely $Fi(2,3)$, $Fi(2,4)$, $Ui(2,3)$, and $Ui(2,4)$; and 4 outputs $Bo(2,3)$, $Bo(2,4)$, $Fo(2,3)$, and $Fo(2,4)$. The stage (ring 2, stage 1) also consists of six 2:1 Muxes namely $F(2,3)$, $F(2,4)$, $U(2,3)$, $U(2,4)$, $B(2,3)$, and $B(2,4)$. The 2:1 Mux $F(2,3)$ has two inputs namely $Fi(2,3)$ and $Fi(2,4)$ and has one output $Fo(2,3)$. The 2:1 Mux $F(2,4)$ has two inputs namely $Fi(2,3)$ and $Fi(2,4)$ and has one output $Fo(2,4)$.

The 2:1 Mux $U(2,3)$ has two inputs namely $Ui(2,3)$ and $Fo(2,3)$ and has one output $Uo(2,3)$. The 2:1 Mux $U(2,4)$ has two inputs namely $Ui(2,4)$ and $Fo(2,4)$ and has one output $Uo(2,4)$. The 2:1 Mux $B(2,3)$ has two inputs namely $Uo(2,3)$ and $Uo(2,4)$ and has one output $Bo(2,3)$. The 2:1 Mux $B(2,4)$ has two inputs namely $Uo(2,3)$ and $Uo(2,4)$ and has one output $Bo(2,4)$.

The output $Fo(2,1)$ of the stage (ring 2, stage 0) is connected to the input $Fi(2,3)$ of the stage (ring 2, stage 1), is an internal connection between stage 0 and stage 1 of the ring 2. And the output $Bo(2,3)$ of the stage (ring 2, stage 1) is connected to the input $Ui(2,1)$ of the stage (ring 2, stage 0), is another internal connection between stage 0 and stage 1 of the ring 1.

The stage (ring 2, stage “n-1”) consists of 4 inputs namely $Ri(2,2n-1)$, $Ri(2,2n)$, $Ui(1,2n-1)$, and $Ui(1,2n)$; and 4 outputs $Bo(1,2n-1)$, $Bo(1,2n)$, $Fo(1,2n-1)$, and $Fo(1,2n)$. The stage (ring 2, stage “n-1”) also consists of eight 2:1 Muxes namely $R(2,2n-1)$, $R(2,2n)$, $F(2,2n-1)$, $F(1,2n)$, $U(1,2n-1)$, $U(1,2n)$, $B(1,2n-1)$, and $B(1,2n)$. The 2:1 Mux $R(2,2n-1)$ has two inputs namely $Ri(2,2n-1)$ and $Bo(2,2n-1)$ and has one output $Ro(2,2n-1)$. The 2:1 Mux $R(2,2n)$ has two inputs namely $Ri(2,2n)$ and $Bo(2,2n)$ and has one output $Ro(2,2n)$. The 2:1 Mux $F(2,2n-1)$ has two inputs namely $Ro(2,2n-1)$ and $Ro(2,2n)$ and has one output $Fo(2,2n-1)$. The 2:1 Mux $F(2,2n)$ has two inputs namely $Ro(2,2n-1)$ and $Ro(2,2n)$ and has one output $Fo(2,2n)$.

The 2:1 Mux $U(2,2n-1)$ has two inputs namely $Ui(2,2n-1)$ and $Fo(2,2n-1)$ and has one output $Uo(2,2n-1)$. The 2:1 Mux $U(2,2n)$ has two inputs namely $Ui(2,2n)$ and $Fo(2,2n)$ and has one output $Uo(2,2n)$. The 2:1 Mux $B(2,2n-1)$ has two inputs namely $Uo(2,2n-1)$ and $Uo(2,2n)$ and has one output $Bo(2,2n-1)$. The 2:1 Mux $B(2,2n)$ has two inputs namely $Uo(2,2n-1)$ and $Uo(2,2n)$ and has one output $Bo(2,2n)$.

The stage (ring 2, stage “n”) consists of 4 inputs namely $Ri(2,2n+1)$, $Ri(2,2n+2)$, $Ui(2,2n+1)$, and $Ui(2,2n+2)$; and 4 outputs $Bo(2,2n+1)$, $Bo(2,2n+2)$, $Fo(2,2n+1)$, and $Fo(2,2n+2)$. The stage (ring 2, stage “n”) also consists of eight 2:1 Muxes namely $R(2,2n+1)$, $R(2,2n+2)$, $F(2,2n+1)$, $F(2,2n+2)$, $U(2,2n+1)$, $U(2,2n+2)$, $B(2,2n+1)$, and $B(2,2n+2)$. The 2:1 Mux $R(2,2n+1)$ has two inputs namely $Ri(2,2n+1)$ and $Bo(2,2n+1)$ and has one output $Ro(2,2n+1)$. The 2:1 Mux $R(2,2n+2)$ has two inputs namely $Ri(2,2n+2)$ and $Bo(2,2n+2)$ and has one output $Ro(2,2n+2)$. The 2:1 Mux $F(2,2n+1)$ has two inputs namely $Ro(2,2n+1)$ and $Ro(2,2n+2)$ and has one output $Fo(2,2n+1)$. The 2:1 Mux $F(2,2n+2)$ has two inputs namely $Ro(2,2n+1)$ and $Ro(2,2n+2)$ and has one output $Fo(2,2n+2)$.

The 2:1 Mux $U(2,2n+1)$ has two inputs namely $Ui(2,2n+1)$ and $Fo(2,2n+1)$ and has one output $Uo(2,2n+1)$. The 2:1 Mux $U(2,2n+2)$ has two inputs namely $Ui(2,2n+2)$ and $Fo(2,2n+2)$ and has one output $Uo(2,2n+2)$. The 2:1 Mux $B(2,2n+1)$ has two inputs namely $Uo(2,2n+1)$ and $Uo(2,2n+2)$ and has one output $Bo(2,2n+1)$. The 2:1 Mux $B(2,2n+2)$ has two inputs namely $Uo(2,2n+1)$ and $Uo(2,2n+2)$ and has one output $Bo(2,2n+2)$.

The output $Fo(2,2n-1)$ of the stage (ring 2, stage “n-1”) is connected to the input $Ri(2,2n+1)$ of the stage (ring 2, stage “n”), is an internal connection between stage “n-1” and stage “n” of the ring 1. And the output $Bo(2,2n+1)$ of the stage (ring 2, stage “n”) is connected to the input $Ui(2,2n-1)$ of the stage (ring 2, stage “n-1”), is another internal connection between stage “n-1” and stage “n” of the ring 1.

Each stage of any ring of the partial multi-stage hierarchical network $V_{Comb}(N_1, N_2, d, s)$ 100A consists of 4 inputs and $2*d=4$ outputs. Even though the stages (ring 1, stage 0), (ring 1, stage 1), (ring 2, stage “n-1”), and (ring 2, stage “n”) each have eight 2:1 muxes, and the stages (ring 2, stage 0), (ring 2, stage 1), (ring 1, stage “m-1”), and (ring 1, stage “m”) each have six 2:1 muxes, in other embodiments any of these stages can be one of the four by four switch diagrams

13

namely **200A** of FIG. 2A, **200B** of FIG. 2B, **200C** of FIG. 2C, and one of the eight by four switch diagrams namely **200E** of FIG. 2E.

Referring to diagram **100B** in FIG. 1B, in one embodiment, an exemplary partial multi-stage hierarchical network $V_{Comb}(N_1, N_2, d, s)$ where $N_1=400$; $N_2=800$; $d=2$; and $s=1$ corresponding to one computational block, with each computational block having 8 inlet links namely **I1**, **I2**, **I3**, **I4**, **I5**, **I6**, **I7**, and **I8**; and 4 outlet links namely **O1**, **O2**, **O3**, and **O4**. And for each computational block the corresponding partial multi-stage hierarchical network $V_{Comb}(N_1, N_2, d, s)$ **100B** consists of two rings **110** and **120**, where ring **110** consists of “m+1” stages namely (ring 1, stage 0), (ring 1, stage 1), . . . (ring 1, stage “k-1”), and (ring 1, stage “k”), and ring **120** consists of “n+1” stages namely (ring 2, stage 0), (ring 2, stage 1), . . . (ring 2, stage “n-1”), and (ring 2, stage “n”), where “m” and “n” are positive integers.

Ring **110** has inlet links $Ri(1,1)$ and $Ri(1,2)$ from the left-hand side, and has outlet links $Bo(1,1)$ and $Bo(1,2)$ from left-hand side. Ring **110** also has inlet links $Ui(1,2m+1)$ and $Ui(1,2m+2)$ from the right-hand side, and has outlet links $Fo(1,2m+1)$ and $Fo(1,2m+2)$ from right-hand side. Ring **120** has inlet links $Fi(2,1)$ and $Fi(2,2)$ from left-hand side, and outlet links $Bo(2,1)$ and $Bo(2,2)$ from left-hand side. Ring **120** also has inlet links $Ui(2,2n+1)$ and $Ui(2,2n+2)$ from the right-hand side, and has outlet links $Fo(2,2n+1)$ and $Fo(2,2n+2)$ from right-hand side.

And the partial multi-stage hierarchical network $V_{Comb}(N_1, N_2, d, s)$ **100B** consists of 8 inlet links and 4 outlet links corresponding to the two rings **110** and **120**. From left-hand side, outlet link **O1** of the computational block is connected to inlet link $Ri(1,1)$ of ring **110** and also inlet link of $Fi(2,1)$ of ring **120**. Similarly from left-hand side, outlet link **O2** of the computational block is connected to inlet link $Ri(1,2)$ of Ring **110** and also inlet link of $Fi(2,2)$ of Ring **120**. And from left-hand side, outlet link $Bo(1,1)$ of Ring **110** is connected to inlet link **I1** of the computational block. From left-hand side, Outlet link $Bo(1,2)$ of Ring **110** is connected to inlet link **I2** of the computational block. Similarly from left-hand side, outlet link $Bo(2,1)$ of Ring **120** is connected to inlet link **I3** of the computational block. From left-hand side, outlet link $Bo(2,2)$ of Ring **120** is connected to inlet link **I4** of the computational block.

From right-hand side, outlet link **O3** of the computational block is connected to inlet link $Ui(1,2m+1)$ of ring **110** and also inlet link of $Ui(2,2n+1)$ of ring **120**. Similarly from right-hand side, outlet link **O4** of the computational block is connected to inlet link $Ui(1,2m+2)$ of Ring **110** and also inlet link of $Ui(2,2n+2)$ of Ring **120**. And from right-hand side, outlet link $Fo(1,2m+1)$ of Ring **110** is connected to inlet link **I5** of the computational block. From right-hand side, outlet link $Fo(1,2m+2)$ of Ring **110** is connected to inlet link **I6** of the computational block. Similarly from right-hand side, outlet link $Fo(2,2n+1)$ of Ring **120** is connected to inlet link **I7** of the computational block. From right-hand side, outlet link $Fo(2,2n+2)$ of Ring **120** is connected to inlet link **I8** of the computational block.

Since in this embodiment outlet link **O1** of the computational block is connected to both inlet link $Ri(1,1)$ of ring **110** and inlet link $Fi(2,1)$ of ring **120**; outlet link **O2** of the computational block is connected to both inlet link $Ri(1,2)$ of ring **110** and inlet link $Fi(2,2)$ of ring **120**; outlet link **O3** of the computational block is connected to both inlet link $Ui(1,2m+1)$ of ring **110** and inlet link $Ui(2,2n+1)$ of ring **120**; and outlet link **O4** of the computational block is connected to both inlet link $Ui(1,2m+2)$ of ring **110** and inlet

14

link $Ui(2,2n+2)$ of ring **120**, the partial multi-stage hierarchical network $V_{Comb}(N_1, N_2, d, s)$ **100B** consists of 4 inlet links and 8 outlet links.

Referring to two dimensional grid **800** in FIG. 8 illustrates, in another embodiment, each block of 2D-grid **800** consists of one of the partial multi-stage hierarchical network $V_{Comb}(N_1, N_2, d, s)$ **100B** with 4 inlet links and 8 outlet links and the corresponding computational block with 8 inlet links and 4 outlet links. For example block (1,1) of 2D-grid **800** consists of one of the partial multi-stage hierarchical network $V_{Comb}(N_1, N_2, d, s)$ **100B** with 4 inlet links and 8 outlet links and the corresponding computational block with 8 inlet links and 4 outlet links. Similarly each of the 100 blocks of 2D-grid **800** has a separate partial multi-stage hierarchical network $V_{Comb}(N_1, N_2, d, s)$ **100B** with 4 inlet links and 8 outlet links and the corresponding computational block with 8 inlet links and 4 outlet links. Hence the complete multi-stage hierarchical network $V_{Comb}(N_1, N_2, d, s)$ corresponding to 2D-grid **800** has $N_1=400$ inlet links and $N_2=800$ outlet links. Since there are 100 computational blocks each one corresponding to one of the blocks with each computational block having 8 inlet links and 4 outlet links. Also the 2D-grid **800** is organized in the fourth quadrant of the 2D-Plane. In other embodiments the 2D-grid **800** may be organized as either first quadrant, or second quadrant or third quadrant of the 2D-Plane.

Referring to partial multi-stage hierarchical network $V_{Comb}(N_1, N_2, d, s)$ **100B** in FIG. 1B, the stage (ring 1, stage 0) consists of 4 inputs namely $Ri(1,1)$, $Ri(1,2)$, $Ui(1,1)$, and $Ui(1,2)$; and 4 outputs $Bo(1,1)$, $Bo(1,2)$, $Fo(1,1)$, and $Fo(1,2)$. The stage (ring 1, stage 0) also consists of eight 2:1 multiplexers (A multiplexer is hereinafter called a “mux”) namely $R(1,1)$, $R(1,2)$, $F(1,1)$, $F(1,2)$, $U(1,1)$, $U(1,2)$, $B(1,1)$, and $B(1,2)$. The 2:1 Mux $R(1,1)$ has two inputs namely $Ri(1,1)$ and $Bo(1,1)$ and has one output $Ro(1,1)$. The 2:1 Mux $R(1,2)$ has two inputs namely $Ri(1,2)$ and $Bo(1,2)$ and has one output $Ro(1,2)$. The 2:1 Mux $F(1,1)$ has two inputs namely $Ro(1,1)$ and $Ro(1,2)$ and has one output $Fo(1,1)$. The 2:1 Mux $F(1,2)$ has two inputs namely $Ro(1,1)$ and $Ro(1,2)$ and has one output $Fo(1,2)$.

The 2:1 Mux $U(1,1)$ has two inputs namely $Ui(1,1)$ and $Fo(1,1)$ and has one output $Uo(1,1)$. The 2:1 Mux $U(1,2)$ has two inputs namely $Ui(1,2)$ and $Fo(1,2)$ and has one output $Uo(1,2)$. The 2:1 Mux $B(1,1)$ has two inputs namely $Uo(1,1)$ and $Uo(1,2)$ and has one output $Bo(1,1)$. The 2:1 Mux $B(1,2)$ has two inputs namely $Uo(1,1)$ and $Uo(1,2)$ and has one output $Bo(1,2)$.

The stage (ring 1, stage 1) consists of 4 inputs namely $Ri(1,3)$, $Ri(1,4)$, $Ui(1,3)$, and $Ui(1,4)$; and 4 outputs $Bo(1,3)$, $Bo(1,4)$, $Fo(1,3)$, and $Fo(1,4)$. The stage (ring 1, stage 1) also consists of eight 2:1 Muxes namely $R(1,3)$, $R(1,4)$, $F(1,3)$, $F(1,4)$, $U(1,3)$, $U(1,4)$, $B(1,3)$, and $B(1,4)$. The 2:1 Mux $R(1,3)$ has two inputs namely $Ri(1,3)$ and $Bo(1,3)$ and has one output $Ro(1,3)$. The 2:1 Mux $R(1,4)$ has two inputs namely $Ri(1,4)$ and $Bo(1,4)$ and has one output $Ro(1,4)$. The 2:1 Mux $F(1,3)$ has two inputs namely $Ro(1,3)$ and $Ro(1,4)$ and has one output $Fo(1,3)$. The 2:1 Mux $F(1,4)$ has two inputs namely $Ro(1,3)$ and $Ro(1,4)$ and has one output $Fo(1,4)$.

The 2:1 Mux $U(1,3)$ has two inputs namely $Ui(1,3)$ and $Fo(1,3)$ and has one output $Uo(1,3)$. The 2:1 Mux $U(1,4)$ has two inputs namely $Ui(1,4)$ and $Fo(1,4)$ and has one output $Uo(1,4)$. The 2:1 Mux $B(1,3)$ has two inputs namely $Uo(1,3)$ and $Uo(1,4)$ and has one output $Bo(1,3)$. The 2:1 Mux $B(1,4)$ has two inputs namely $Uo(1,3)$ and $Uo(1,4)$ and has one output $Bo(1,4)$.

The output $Fo(1,1)$ of the stage (ring 1, stage 0) is connected to the input $Ri(1,3)$ of the stage (ring 1, stage 1) which is called hereinafter an internal connection between two successive stages of a ring. And the output $Bo(1,3)$ of the stage (ring 1, stage 1) is connected to the input $Ui(1,1)$ of the stage (ring 1, stage 0), is another internal connection between stage 0 and stage 1 of the ring 1.

The stage (ring 1, stage "m-1") consists of 4 inputs namely $Fi(1,2m-1)$, $Fi(1,2m)$, $Ui(1,2m-1)$, and $Ui(1,2m)$; and 4 outputs $Bo(1,2m-1)$, $Bo(1,2m)$, $Fo(1,2m-1)$, and $Fo(1,2m)$. The stage (ring 1, stage "m-1") also consists of six 2:1 Muxes namely $F(1,2m-1)$, $F(1,2m)$, $U(1,2m-1)$, $U(1,2m)$, $B(1,2m-1)$, and $B(1,2m)$. The 2:1 Mux $F(1,2m-1)$ has two inputs namely $Fi(1,2m-1)$ and $Fi(1,2m)$ and has one output $Fo(1,2m-1)$. The 2:1 Mux $F(1,2m)$ has two inputs namely $Fi(1,2m-1)$ and $Fi(1,2m)$ and has one output $Fo(1,2m)$.

The 2:1 Mux $U(1,2m-1)$ has two inputs namely $Ui(1,2m-1)$ and $Fo(1,2m-1)$ and has one output $Uo(1,2m-1)$. The 2:1 Mux $U(1,2m)$ has two inputs namely $Ui(1,2m)$ and $Fo(1,2m)$ and has one output $Uo(1,2m)$. The 2:1 Mux $B(1,2m-1)$ has two inputs namely $Uo(1,2m-1)$ and $Uo(1,2m)$ and has one output $Bo(1,2m-1)$. The 2:1 Mux $B(1,2m)$ has two inputs namely $Uo(1,2m-1)$ and $Uo(1,2m)$ and has one output $Bo(1,2m)$.

The stage (ring 1, stage "m") consists of 4 inputs namely $Fi(1,2m+1)$, $Fi(1,2m+2)$, $Ui(1,2m+1)$, and $Ui(1,2m+2)$; and 4 outputs $Bo(1,2m+1)$, $Bo(1,2m+2)$, $Fo(1,2m+1)$, and $Fo(1,2m+2)$. The stage (ring 1, stage "m") also consists of six 2:1 Muxes namely $F(1,2m+1)$, $F(1,2m+2)$, $U(1,2m+1)$, $U(1,2m+2)$, $B(1,2m+1)$, and $B(1,2m+2)$. The 2:1 Mux $F(1,2m+1)$ has two inputs namely $Fi(1,2m+1)$ and $Fi(1,2m+2)$ and has one output $Fo(1,2m+1)$. The 2:1 Mux $F(1,2m+2)$ has two inputs namely $Fi(1,2m+1)$ and $Fi(1,2m+2)$ and has one output $Fo(1,2m+2)$.

The 2:1 Mux $U(1,2m+1)$ has two inputs namely $Ui(1,2m+1)$ and $Fo(1,2m+1)$ and has one output $Uo(1,2m+1)$. The 2:1 Mux $U(1,2m+2)$ has two inputs namely $Ui(1,2m+2)$ and $Fo(1,2m+2)$ and has one output $Uo(1,2m+2)$. The 2:1 Mux $B(1,2m+1)$ has two inputs namely $Uo(1,2m+1)$ and $Uo(1,2m+2)$ and has one output $Bo(1,2m+1)$. The 2:1 Mux $B(1,2m+2)$ has two inputs namely $Uo(1,2m+1)$ and $Uo(1,2m+2)$ and has one output $Bo(1,2m+2)$.

The output $Fo(1,2m-1)$ of the stage (ring 1, stage "m-1") is connected to the input $Fi(1,2m+1)$ of the stage (ring 1, stage "m"), is an internal connection between stage "m-1" and stage "m" of the ring 1. And the output $Bo(1,2m+1)$ of the stage (ring 1, stage "m") is connected to the input $Ui(1,2m-1)$ of the stage (ring 1, stage "m-1"), is another internal connection between stage "m-1" and stage "m" of the ring 1.

Just the same way the stages (ring 1, stage 0), (ring 1, stage 1), there are also stages (ring 1, stage 2), (ring 1, stage 3), . . . (ring 1, stage "m-1"), (ring 1, stage "m") in that order, where the stages from (ring 1, stage 2), (ring 1, stage 3), . . . , (ring 1, stage "m-2") are not shown in the diagram 100B. Just the same way the two successive stages (ring 1, stage 0) and (ring 1, stage 1) have internal connections between them as described before, any two successive stages have similar internal connections. For example (ring 1, stage 1) and (ring 1, stage 2) have similar internal connections and (ring 1, stage "m-2") and (ring 1, stage "m-1") have similar internal connections.

Stage (ring 1, stage 0) is also called hereinafter the "entry stage" or "first stage" of ring 1, since inlet links and outlet links of the computational block are directly connected to

stage (ring 1, stage 0). Also stage (ring 1, stage "m") is hereinafter the "last stage" or "root stage" of ring 1.

The stage (ring 2, stage 0) consists of 4 inputs namely $Fi(2,1)$, $Fi(2,2)$, $Ui(2,1)$, and $Ui(2,2)$; and 4 outputs $Bo(2,1)$, $Bo(2,2)$, $Fo(2,1)$, and $Fo(2,2)$. The stage (ring 2, stage 0) also consists of six 2:1 Muxes namely $F(2,1)$, $F(2,2)$, $U(2,1)$, $U(2,2)$, $B(2,1)$, and $B(2,2)$. The 2:1 Mux $F(2,1)$ has two inputs namely $Fi(2,1)$ and $Fi(2,2)$ and has one output $Fo(2,1)$. The 2:1 Mux $F(2,2)$ has two inputs namely $Fi(2,1)$ and $Fi(2,2)$ and has one output $Fo(2,2)$.

The 2:1 Mux $U(2,1)$ has two inputs namely $Ui(2,1)$ and $Fo(2,1)$ and has one output $Uo(2,1)$. The 2:1 Mux $U(2,2)$ has two inputs namely $Ui(2,2)$ and $Fo(2,2)$ and has one output $Uo(2,2)$. The 2:1 Mux $B(2,1)$ has two inputs namely $Uo(2,1)$ and $Uo(2,2)$ and has one output $Bo(2,1)$. The 2:1 Mux $B(2,2)$ has two inputs namely $Uo(2,1)$ and $Uo(2,2)$ and has one output $Bo(2,2)$.

The stage (ring 2, stage 1) consists of 4 inputs namely $Fi(2,3)$, $Fi(2,4)$, $Ui(2,3)$, and $Ui(2,4)$; and 4 outputs $Bo(2,3)$, $Bo(2,4)$, $Fo(2,3)$, and $Fo(2,4)$. The stage (ring 2, stage 1) also consists of six 2:1 Muxes namely $F(2,3)$, $F(2,4)$, $U(2,3)$, $U(2,4)$, $B(2,3)$, and $B(2,4)$. The 2:1 Mux $F(2,3)$ has two inputs namely $Fi(2,3)$ and $Fi(2,4)$ and has one output $Fo(2,3)$. The 2:1 Mux $F(2,4)$ has two inputs namely $Fi(2,3)$ and $Fi(2,4)$ and has one output $Fo(2,4)$.

The 2:1 Mux $U(2,3)$ has two inputs namely $Ui(2,3)$ and $Fo(2,3)$ and has one output $Uo(2,3)$. The 2:1 Mux $U(2,4)$ has two inputs namely $Ui(2,4)$ and $Fo(2,4)$ and has one output $Uo(2,4)$. The 2:1 Mux $B(2,3)$ has two inputs namely $Uo(2,3)$ and $Uo(2,4)$ and has one output $Bo(2,3)$. The 2:1 Mux $B(2,4)$ has two inputs namely $Uo(2,3)$ and $Uo(2,4)$ and has one output $Bo(2,4)$.

The output $Fo(2,1)$ of the stage (ring 2, stage 0) is connected to the input $Fi(2,3)$ of the stage (ring 2, stage 1), is an internal connection between stage 0 and stage 1 of the ring 2. And the output $Bo(2,3)$ of the stage (ring 2, stage 1) is connected to the input $Ui(2,1)$ of the stage (ring 2, stage 0), is another internal connection between stage 0 and stage 1 of the ring 1.

The stage (ring 2, stage "n-1") consists of 4 inputs namely $Ri(2,2n-1)$, $Ri(2,2n)$, $Ui(1,2n-1)$, and $Ui(1,2n)$; and 4 outputs $Bo(1,2n-1)$, $Bo(1,2n)$, $Fo(1,2n-1)$, and $Fo(1,2n)$. The stage (ring 2, stage "n-1") also consists of eight 2:1 Muxes namely $R(2,2n-1)$, $R(2,2n)$, $F(2,2n-1)$, $F(1,2n)$, $U(1,2n-1)$, $U(1,2n)$, $B(1,2n-1)$, and $B(1,2n)$. The 2:1 Mux $R(2,2n-1)$ has two inputs namely $Ri(2,2n-1)$ and $Bo(2,2n-1)$ and has one output $Ro(2,2n-1)$. The 2:1 Mux $R(2,2n)$ has two inputs namely $Ri(2,2n)$ and $Bo(2,2n)$ and has one output $Ro(2,2n)$. The 2:1 Mux $F(2,2n-1)$ has two inputs namely $Ro(2,2n-1)$ and $Ro(2,2n)$ and has one output $Fo(2,2n-1)$. The 2:1 Mux $F(2,2n)$ has two inputs namely $Ro(2,2n-1)$ and $Ro(2,2n)$ and has one output $Fo(2,2n)$.

The 2:1 Mux $U(2,2n-1)$ has two inputs namely $Ui(2,2n-1)$ and $Fo(2,2n-1)$ and has one output $Uo(2,2n-1)$. The 2:1 Mux $U(2,2n)$ has two inputs namely $Ui(2,2n)$ and $Fo(2,2n)$ and has one output $Uo(2,2n)$. The 2:1 Mux $B(2,2n-1)$ has two inputs namely $Uo(2,2n-1)$ and $Uo(2,2n)$ and has one output $Bo(2,2n-1)$. The 2:1 Mux $B(2,2n)$ has two inputs namely $Uo(2,2n-1)$ and $Uo(2,2n)$ and has one output $Bo(2,2n)$.

The stage (ring 2, stage "n") consists of 4 inputs namely $Ri(2,2n+1)$, $Ri(2,2n+2)$, $Ui(2,2n+1)$, and $Ui(2,2n+2)$; and 4 outputs $Bo(2,2n+1)$, $Bo(2,2n+2)$, $Fo(2,2n+1)$, and $Fo(2,2n+2)$. The stage (ring 2, stage "n") also consists of eight 2:1 Muxes namely $R(2,2n+1)$, $R(2,2n+2)$, $F(2,2n+1)$, $F(2,2n+2)$, $U(2,2n+1)$, $U(2,2n+2)$, $B(2,2n+1)$, and $B(2,2n+2)$. The 2:1 Mux $R(2,2n+1)$ has two inputs namely $Ri(2,2n+1)$ and

Bo(2,2n+1) and has one output Ro(2,2n+1). The 2:1 Mux R(2,2n+2) has two inputs namely Ri(2,2n+2) and Bo(2,2n+2) and has one output Ro(2,2n+2). The 2:1 Mux F(2,2n+1) has two inputs namely Ro(2,2n+1) and Ro(2,2n+2) and has one output Fo(2,2n+1). The 2:1 Mux F(2,2n+2) has two inputs namely Ro(2,2n+1) and Ro(2,2n+2) and has one output Fo(2,2n+2).

The 2:1 Mux U(2,2n+1) has two inputs namely Ui(2,2n+1) and Fo(2,2n+1) and has one output Uo(2,2n+1). The 2:1 Mux U(2,2n+2) has two inputs namely Ui(2,2n+2) and Fo(2,2n+2) and has one output Uo(2,2n+2). The 2:1 Mux B(2,2n+1) has two inputs namely Uo(2,2n+1) and Uo(2,2n+2) and has one output Bo(2,2n+1). The 2:1 Mux B(2,2n+2) has two inputs namely Uo(2,2n+1) and Uo(2,2n+2) and has one output Bo(2,2n+2).

The output Fo(2,2n-1) of the stage (ring 2, stage "n-1") is connected to the input Ri(2,2n+1) of the stage (ring 2, stage "n"), is an internal connection between stage "n-1" and stage "n" of the ring 1. And the output Bo(2,2n+1) of the stage (ring 2, stage "n") is connected to the input Ui(2,2n-1) of the stage (ring 2, stage "n-1"), is another internal connection between stage "n-1" and stage "n" of the ring 1.

Each stage of any ring of the partial multi-stage hierarchical network $V_{Comb}(N_1, N_2, d, s)$ **100B** consists of 4 inputs and $2*d=4$ outputs. Even though the stages (ring 1, stage 0), (ring 1, stage 1), (ring 2, stage "n-1"), and (ring 2, stage "n") each have eight 2:1 muxes, and the stages (ring 2, stage 0), (ring 2, stage 1), (ring 1, stage "m-1"), and (ring 1, stage "m") each have six 2:1 muxes, in other embodiments any of these stages can be one of the four by four switch diagrams namely **200A** of FIG. 2A, **200B** of FIG. 2B, **200C** of FIG. 2C, and one of the eight by four switch diagrams namely **200E** of FIG. 2E.

In general, any ring of the partial multi-stage hierarchical network $V_{Comb}(N_1, N_2, d, s)$ may have inputs and outputs connected from computational block from either only from left-hand side as in the partial multi-stage hierarchical network $V_{Comb}(N_1, N_2, d, s)$ **100A**; or only from right-hand side; or from both left-hand and right-hand sides as in the partial multi-stage hierarchical network $V_{Comb}(N_1, N_2, d, s)$ **100B**.

FIG. 2A illustrates a stage (ring "k", stage "m") **200A** consists of 4 inputs namely Fi(k,2m+1), Fi(k,2m+2), Ui(k,2m+1), and Ui(k,2m+2); and 4 outputs Bo(k,2m+1), Bo(k,2m+2), Fo(k,2m+1), and Fo(k,2m+2). The stage (ring "k", stage "m") also consists of six 2:1 Muxes namely F(k,2m+1), F(k,2m+2), U(k,2m+1), U(k,2m+2), B(k,2m+1), and B(k,2m+2). The 2:1 Mux F(k,2m+1) has two inputs namely Fi(k,2m+1) and Fi(k,2m+2) and has one output Fo(k,2m+1). The 2:1 Mux F(k,2m+2) has two inputs namely Fi(k,2m+1) and Fi(k,2m+2) and has one output Fo(k,2m+2).

The 2:1 Mux U(k,2m+1) has two inputs namely Ui(k,2m+1) and Fo(k,2m+1) and has one output Uo(k,2m+1). The 2:1 Mux U(k,2m+2) has two inputs namely Ui(k,2m+2) and Fo(k,2m+2) and has one output Uo(k,2m+2). The 2:1 Mux B(k,2m+1) has two inputs namely Uo(k,2m+1) and Uo(k,2m+2) and has one output Bo(k,2m+1). The 2:1 Mux B(k,2m+2) has two inputs namely Uo(k,2m+1) and Uo(k,2m+2) and has one output Bo(k,2m+2).

FIG. 2B illustrates a stage (ring "k", stage "m") **200B** consists of 4 inputs namely Ri(k,2m+1), Ri(k,2m+2), Ui(k,2m+1), and Ui(k,2m+2); and 4 outputs Bo(k,2m+1), Bo(k,2m+2), Fo(k,2m+1), and Fo(k,2m+2). The stage (ring "k", stage "m") also consists of eight 2:1 Muxes namely R(k,2m+1), R(k,2m+2), F(k,2m+1), F(k,2m+2), U(k,2m+1), U(k,2m+2), B(k,2m+1), and B(k,2m+2). The 2:1 Mux R(k,2m+1) has two inputs namely Ri(k,2m+1) and Bo(k,2m+1)

and has one output Ro(k,2m+1). The 2:1 Mux R(k,2m+2) has two inputs namely Ri(k,2m+2) and Bo(k,2m+2) and has one output Ro(k,2m+2). The 2:1 Mux F(k,2m+1) has two inputs namely Ro(k,2m+1) and Ro(k,2m+2) and has one output Fo(k,2m+1). The 2:1 Mux F(k,2m+2) has two inputs namely Ro(k,2m+1) and Ro(k,2m+2) and has one output Fo(k,2m+2).

The 2:1 Mux U(k,2m+1) has two inputs namely Ui(k,2m+1) and Fo(k,2m+1) and has one output Uo(k,2m+1). The 2:1 Mux U(k,2m+2) has two inputs namely Ui(k,2m+2) and Fo(k,2m+2) and has one output Uo(k,2m+2). The 2:1 Mux B(k,2m+1) has two inputs namely Uo(k,2m+1) and Uo(k,2m+2) and has one output Bo(k,2m+1). The 2:1 Mux B(k,2m+2) has two inputs namely Uo(k,2m+1) and Uo(k,2m+2) and has one output Bo(k,2m+2).

FIG. 2C illustrates a stage (ring "k", stage "m") **200C** consists of 4 inputs namely Fi(k,2m+1), Fi(k,2m+2), Bi(k,2m+1), and Bi(k,2m+2); and 4 outputs Bo(k,2m+1), Bo(k,2m+2), Fo(k,2m+1), and Fo(k,2m+2). The stage (ring "k", stage "m") also consists of four 2:1 Muxes namely F(k,2m+1), F(k,2m+2), B(k,2m+1), and B(k,2m+2). The 2:1 Mux F(k,2m+1) has two inputs namely Fi(k,2m+1) and Fi(k,2m+2) and has one output Fo(k,2m+1). The 2:1 Mux F(k,2m+2) has two inputs namely Fi(k,2m+1) and Fi(k,2m+2) and has one output Fo(k,2m+2).

The 2:1 Mux B(k,2m+1) has two inputs namely Bi(k,2m+1) and Bi(k,2m+2) and has one output Bo(k,2m+1). The 2:1 Mux B(k,2m+2) has two inputs namely Bi(k,2m+1) and Bi(k,2m+2) and has one output Bo(k,2m+2).

However the stage "m+1" of ring "k" with "m+1" stages of the partial multi-stage hierarchical network $V_{Comb}(N_1, N_2, d, s)$, in another embodiment, may have 2 inputs and 2 outputs as shown in diagram **200D** in FIG. 2D. FIG. 2D illustrates a stage (ring "k", stage "m") **200D** consists of 2 inputs namely Fi(k,2m+1) and Fi(k,2m+2); and 2 outputs Fo(k,2m+1) and Fo(k,2m+2). The stage (ring "k", stage "m") also consists of two 2:1 Muxes namely F(k,2m+1), F(k,2m+2). The 2:1 Mux F(k,2m+1) has two inputs namely Fi(k,2m+1) and Fi(k,2m+2) and has one output Fo(k,2m+1). The 2:1 Mux F(k,2m+2) has two inputs namely Fi(k,2m+1) and Fi(k,2m+2) and has one output Fo(k,2m+2). A stage with d=2 inputs and d=2 outputs is typically the "last stage" or "root stage" of ring.

However the stage "m+1" of ring "k" with "m+1" stages of the partial multi-stage hierarchical network $V_{Comb}(N_1, N_2, d, s)$, in another embodiment, may have 8 inputs and 2 outputs as shown in diagram **200E** in FIG. 2E. FIG. 2E illustrates a stage (ring "k", stage "m") **200E** consists of 8 inputs namely Ri(k,2m+1), Ri(k,2m+2), Ui(k,2m+1), Ui(k,2m+2), J, K, L, and M; and 4 outputs Bo(k,2m+1), Bo(k,2m+2), Fo(k,2m+1), and Fo(k,2m+2). The stage (ring "k", stage "m") also consists of eight 2:1 Muxes namely R(k,2m+1), R(k,2m+2), F(k,2m+1), F(k,2m+2), U(k,2m+1), U(k,2m+2), B(k,2m+1), and B(k,2m+2). The 2:1 Mux R(k,2m+1) has two inputs namely Ri(k,2m+1) and J, and has one output Ro(k,2m+1). The 2:1 Mux R(k,2m+2) has two inputs namely Ri(k,2m+2) and K, and has one output Ro(k,2m+2). The 2:1 Mux F(k,2m+1) has two inputs namely Ro(k,2m+1) and Uo(k,2m+2), and has one output Fo(k,2m+1). The 2:1 Mux F(k,2m+2) has two inputs namely Ro(k,2m+2) and Uo(k,2m+1), and has one output Fo(k,2m+2).

The 2:1 Mux U(k,2m+1) has two inputs namely Ui(k,2m+1) and L, and has one output Uo(k,2m+1). The 2:1 Mux U(k,2m+2) has two inputs namely Ui(k,2m+2) and M, and has one output Uo(k,2m+2). The 2:1 Mux B(k,2m+1) has two inputs namely Uo(k,2m+1) and Ro(k,2m+2), and has one output Bo(k,2m+1). The 2:1 Mux B(k,2m+2) has two

inputs namely $Uo(k,2m+2)$ and $Ro(k,2m+1)$, and has one output $Bo(k,2m+2)$. In different embodiments the inputs J, K, L, and M are connected from any of the outputs of any other stages of any ring of any block of the multi-stage hierarchical network $V_{Comb}(N_1, N_2, d, s)$.

The number of stages in a ring of any block may not be equal to the number of stages in any other ring of the same of block or any ring of any other block of the multi-stage hierarchical network $V_{Comb}(N_1, N_2, d, s)$. For example the number of stages in ring 1 of the partial multi-stage hierarchical network $V_{Comb}(N_1, N_2, d, s)$ **100A** or of the partial multi-stage hierarchical network $V_{Comb}(N_1, N_2, d, s)$ **100B** is denoted by “m” and the number of stages in ring 2 of the partial multi-stage hierarchical network is denoted by “n”, and so “m” may or may not be equal to “n”. Similarly the number of stages in ring 2 corresponding to block (3,3) of 2D-grid **800** may not be equal to the number of stages in ring 2 corresponding to block (6,9) of 2D-grid **800**.

Even though the number of inlet links to the computational block is four and the number of outlet links to the computational block is two in the partial multi-stage hierarchical network $V_{Comb}(N_1, N_2, d, s)$ **100A** and the number of inlet links to the computational block is eight and the number of outlet links to the computational block is four in the partial multi-stage hierarchical network $V_{Comb}(N_1, N_2, d, s)$ **100B**, in other embodiments the number of inlet links to the computational block may be any arbitrary number and the number of outlet links to the computational block may also be another arbitrary number. However the number of rings corresponding to the partial multi-stage hierarchical network $V_{Comb}(N_1, N_2, d, s)$ of a block is generally equal to the number of inlet links to the computational block divided by $d=2$ if the inputs and outputs are connected either only from left-hand side or only from right-hand side, if the number of inlet links to the computational block is greater than or equal to the number of outlet links to the computational block. In such a case one or more of the outlet links to the computational block are connected to more than one inlet links of the partial multi-stage hierarchical network $V_{Comb}(N_1, N_2, d, s)$ corresponding to a block. Similarly the number of rings corresponding to the partial multi-stage hierarchical network $V_{Comb}(N_1, N_2, d, s)$ of a block is generally equal to the number of inlet links to the computational block divided by $2*d=4$ if the inputs and outputs are connected from both left-hand side and from right-hand side, if the number of inlet links to the computational block is greater than or equal to the number of outlet links to the computational block.

Otherwise the number of rings corresponding to the partial multi-stage hierarchical network $V_{Comb}(N_1, N_2, d, s)$ of a block is generally equal to the number of outlet links to the computational block divided by $d=2$ if the inputs and outputs are connected either only from left-hand side or only from right-hand side, if the number of outlet links to the computational block is greater than the number of inlet links to the computational block. In such a case one or more of the outlet links of the partial multi-stage hierarchical network $V_{Comb}(N_1, N_2, d, s)$ corresponding to a block are connected to more than one inlet link of the computational block. Similarly the number of rings corresponding to the partial multi-stage hierarchical network $V_{Comb}(N_1, N_2, d, s)$ of a block is generally equal to the number of outlet links to the computational block divided by $2*d=4$ if the inputs and outputs are connected from both left-hand side and from right-hand side, if the number of outlet links to the computational block is greater than or equal to the number of inlet links to the computational block.

In another embodiment, the number of inlet links to the computational block corresponding to a block of 2D-grid of blocks may or may not be equal to the number of inlet links to the computational block corresponding to another block.

Similarly the number of outlet links to the computational block corresponding to a block of 2D-grid of blocks may or may not be equal to the number of outlet links to the computational block corresponding to another block. Hence the total number of rings of the partial multi-stage hierarchical network $V_{Comb}(N_1, N_2, d, s)$ corresponding to a block of 2D-grid of blocks may or may not be equal to the partial multi-stage hierarchical network $V_{Comb}(N_1, N_2, d, s)$ corresponding to another block. For example the total number of rings corresponding to block (4,5) of 2D-grid **800** may be two and the total number of rings in block (5,4) of 2D-grid **800** may be three.

A multi-stage hierarchical network can be represented with the notation $V_{Comb}(N_1, N_2, d, s)$, where N_1 , represents the total number of inlet links of the complete multi-stage hierarchical network and N_2 represents the total number of outlet links of the complete multi-stage hierarchical network, d represents the number of inlet links of any ring in any block of the complete multi-stage hierarchical network either from only left-hand side or only right-hand side, or equivalently the number of outlet links of any ring in any block of the complete multi-stage hierarchical network either from only left-hand side or only right-hand side, (in general $d \geq 2$), and when the inputs and outputs are connected from left-hand side, s is the ratio of number of outgoing links from each stage 0 of any ring in any block to the number of inlet links of any ring in any block of the complete multi-stage hierarchical network (for example the complete multi-stage hierarchical network corresponding to $V_{Comb}(N_1, N_2, d, s)$ **100A** in FIG. 1A, $N_1=200$, $N_2=400$, $d=2$, $s=1$). Also a multi-stage hierarchical network where $N_1=N_2=N$ is represented as $V_{Comb}(N, d, s)$.

The diagram **300A** of FIG. 3A, **300B** of FIG. 3B, **400** of FIG. 4, **500** of FIG. 5, and **600** of FIG. 6 are different embodiments of all the connections between two arbitrary successive stages in two different rings of the same block or two different rings of different blocks of 2D-grid **800**. Referring to diagram **300A** in FIG. 3A illustrates all the connections between two arbitrary successive stages of a ring namely the stages (ring “x”, stage “p”) and (ring “x”, stage “p+1”) and two other arbitrary successive stages of any other ring namely the stages (ring “y”, stage “q”) and (ring “y”, stage “q+1”), of the complete multi-stage hierarchical network $V_{Comb}(N_1, N_2, d, s)$.

The stage (ring “x”, stage “p”) consists of 4 inputs namely $Ri(x,2p+1)$, $Ri(x,2p+2)$, $Ui(x,2p+1)$, and $Ui(x,2p+2)$; and 4 outputs $Bo(x,2p+1)$, $Bo(x,2p+2)$, $Fo(x,2p+1)$, and $Fo(x,2p+2)$. The stage (ring “x”, stage “p”) also consists of eight 2:1 Muxes namely $R(x,2p+1)$, $R(x,2p+2)$, $F(x,2p+1)$, $F(x,2p+2)$, $U(x,2p+1)$, $U(x,2p+2)$, $B(x,2p+1)$, and $B(x,2p+2)$. The 2:1 Mux $R(x,2p+1)$ has two inputs namely $Ri(x,2p+1)$ and $Bo(x,2p+1)$ and has one output $Ro(x,2p+1)$. The 2:1 Mux $R(x,2p+2)$ has two inputs namely $Ri(x,2p+2)$ and $Bo(x,2p+2)$ and has one output $Ro(x,2p+2)$. The 2:1 Mux $F(x,2p+1)$ has two inputs namely $Ro(x,2p+1)$ and $Ro(x,2p+2)$ and has one output $Fo(x,2p+1)$. The 2:1 Mux $F(x,2p+2)$ has two inputs namely $Ro(x,2p+1)$ and $Ro(x,2p+2)$ and has one output $Fo(x,2p+2)$.

The 2:1 Mux $U(x,2p+1)$ has two inputs namely $Ui(x,2p+1)$ and $Fo(x,2p+1)$ and has one output $Uo(x,2p+1)$. The 2:1 Mux $U(x,2p+2)$ has two inputs namely $Ui(x,2p+2)$ and $Fo(x,2p+2)$ and has one output $Uo(x,2p+2)$. The 2:1 Mux $B(x,2p+1)$ has two inputs namely $Uo(x,2p+1)$ and $Uo(x,2p+2)$.

2) and has one output $Bo(x,2p+1)$. The 2:1 Mux $B(x,2p+2)$ has two inputs namely $Uo(x,2p+1)$ and $Uo(x,2p+2)$ and has one output $Bo(x,2p+2)$.

The stage (ring “x”, stage “p+1”) consists of 4 inputs namely $Ri(x,2p+3)$, $Ri(x,2p+4)$, $Ui(x,2p+3)$, and $Ui(x,2p+4)$; and 4 outputs $Bo(x,2p+3)$, $Bo(x,2p+4)$, $Fo(x,2p+3)$, and $Fo(x,2p+4)$. The stage (ring “x”, stage “p+1”) also consists of eight 2:1 Muxes namely $R(x,2p+3)$, $R(x,2p+4)$, $F(x,2p+3)$, $F(x,2p+4)$, $U(x,2p+3)$, $U(x,2p+4)$, $B(x,2p+3)$, and $B(x,2p+4)$. The 2:1 Mux $R(x,2p+3)$ has two inputs namely $Ri(x,2p+3)$ and $Bo(x,2p+3)$ and has one output $Ro(x,2p+3)$. The 2:1 Mux $R(x,2p+4)$ has two inputs namely $Ri(x,2p+4)$ and $Bo(x,2p+4)$ and has one output $Ro(x,2p+4)$. The 2:1 Mux $F(x,2p+3)$ has two inputs namely $Ro(x,2p+3)$ and $Ro(x,2p+4)$ and has one output $Fo(x,2p+3)$. The 2:1 Mux $F(x,2p+4)$ has two inputs namely $Ro(x,2p+3)$ and $Ro(x,2p+4)$ and has one output $Fo(x,2p+4)$.

The 2:1 Mux $U(x,2p+3)$ has two inputs namely $Ui(x,2p+3)$ and $Fo(x,2p+3)$ and has one output $Uo(x,2p+3)$. The 2:1 Mux $U(x,2p+4)$ has two inputs namely $Ui(x,2p+4)$ and $Fo(x,2p+4)$ and has one output $Uo(x,2p+4)$. The 2:1 Mux $B(x,2p+3)$ has two inputs namely $Uo(x,2p+3)$ and $Uo(x,2p+4)$ and has one output $Bo(x,2p+3)$. The 2:1 Mux $B(x,2p+4)$ has two inputs namely $Uo(x,2p+3)$ and $Uo(x,2p+4)$ and has one output $Bo(x,2p+4)$.

The output $Fo(x,2p+1)$ of the stage (ring “x”, stage “p”) is connected to the input $Ri(x,2p+3)$ of the stage (ring “x”, stage “p+1”). And the output $Bo(x,2p+3)$ of the stage (ring “x”, stage “p+1”) is connected to the input $Ui(x,2p+1)$ of the stage (ring “x”, stage “p”).

The stage (ring “y”, stage “q”) consists of 4 inputs namely $Ri(y,2q+1)$, $Ri(y,2q+2)$, $Ui(y,2q+1)$, and $Ui(y,2q+2)$; and 4 outputs $Bo(y,2q+1)$, $Bo(y,2q+2)$, $Fo(y,2q+1)$, and $Fo(y,2q+2)$. The stage (ring “y”, stage “q”) also consists of eight 2:1 Muxes namely $R(y,2q+1)$, $R(y,2q+2)$, $F(y,2q+1)$, $F(y,2q+2)$, $U(y,2q+1)$, $U(y,2q+2)$, $B(y,2q+1)$, and $B(y,2q+2)$. The 2:1 Mux $R(y,2q+1)$ has two inputs namely $Ri(y,2q+1)$ and $Bo(y,2q+1)$ and has one output $Ro(y,2q+1)$. The 2:1 Mux $R(y,2q+2)$ has two inputs namely $Ri(y,2q+2)$ and $Bo(y,2q+2)$ and has one output $Ro(y,2q+2)$. The 2:1 Mux $F(y,2q+1)$ has two inputs namely $Ro(y,2q+1)$ and $Ro(y,2q+2)$ and has one output $Fo(y,2q+1)$. The 2:1 Mux $F(y,2q+2)$ has two inputs namely $Ro(y,2q+1)$ and $Ro(y,2q+2)$ and has one output $Fo(y,2q+2)$.

The 2:1 Mux $U(y,2q+1)$ has two inputs namely $Ui(y,2q+1)$ and $Fo(y,2q+1)$ and has one output $Uo(y,2q+1)$. The 2:1 Mux $U(y,2q+2)$ has two inputs namely $Ui(y,2q+2)$ and $Fo(y,2q+2)$ and has one output $Uo(y,2q+2)$. The 2:1 Mux $B(y,2q+1)$ has two inputs namely $Uo(y,2q+1)$ and $Uo(y,2q+2)$ and has one output $Bo(y,2q+1)$. The 2:1 Mux $B(y,2q+2)$ has two inputs namely $Uo(y,2q+1)$ and $Uo(y,2q+2)$ and has one output $Bo(y,2q+2)$.

The stage (ring “y”, stage “q+1”) consists of 4 inputs namely $Ri(y,2q+3)$, $Ri(y,2q+4)$, $Ui(y,2q+3)$, and $Ui(y,2q+4)$; and 4 outputs $Bo(y,2q+3)$, $Bo(y,2q+4)$, $Fo(y,2q+3)$, and $Fo(y,2q+4)$. The stage (ring “y”, stage “q+1”) also consists of eight 2:1 Muxes namely $R(y,2q+3)$, $R(y,2q+4)$, $F(y,2q+3)$, $F(y,2q+4)$, $U(y,2q+3)$, $U(y,2q+4)$, $B(y,2q+3)$, and $B(y,2q+4)$. The 2:1 Mux $R(y,2q+3)$ has two inputs namely $Ri(y,2q+3)$ and $Bo(y,2q+3)$ and has one output $Ro(y,2q+3)$. The 2:1 Mux $R(y,2q+4)$ has two inputs namely $Ri(y,2q+4)$ and $Bo(y,2q+4)$ and has one output $Ro(y,2q+4)$. The 2:1 Mux $F(y,2q+3)$ has two inputs namely $Ro(y,2q+3)$ and $Ro(y,2q+4)$ and has one output $Fo(y,2q+3)$. The 2:1 Mux $F(y,2q+4)$ has two inputs namely $Ro(y,2q+3)$ and $Ro(y,2q+4)$ and has one output $Fo(y,2q+4)$.

The 2:1 Mux $U(y,2q+3)$ has two inputs namely $Ui(y,2q+3)$ and $Fo(y,2q+3)$ and has one output $Uo(y,2q+3)$. The 2:1 Mux $U(y,2q+4)$ has two inputs namely $Ui(y,2q+4)$ and $Fo(y,2q+4)$ and has one output $Uo(y,2q+4)$. The 2:1 Mux $B(y,2q+3)$ has two inputs namely $Uo(y,2q+3)$ and $Uo(y,2q+4)$ and has one output $Bo(y,2q+3)$. The 2:1 Mux $B(y,2q+4)$ has two inputs namely $Uo(y,2q+3)$ and $Uo(y,2q+4)$ and has one output $Bo(y,2q+4)$.

The output $Fo(y,2q+1)$ of the stage (ring “y”, stage “q”) is connected to the input $Ri(y,2q+3)$ of the stage (ring “y”, stage “q+1”). And the output $Bo(y,2q+3)$ of the stage (ring “y”, stage “q+1”) is connected to the input $Ui(y,2q+1)$ of the stage (ring “y”, stage “q”).

The output $Fo(x,2p+2)$ of the stage (ring “x”, stage “p”) is connected via the wire $Hop(1,1)$ to the input $Ri(y,2q+4)$ of the stage (ring “y”, stage “q+1”). The output $Bo(x,2p+4)$ of the stage (ring “x”, stage “p+1”) is connected via the wire $Hop(1,2)$ to the input $Ui(y,2q+2)$ of the stage (ring “y”, stage “q”).

The output $Fo(y,2q+2)$ of the stage (ring “y”, stage “q”) is connected via the wire $Hop(2,1)$ to the input $Ri(x,2p+4)$ of the stage (ring “x”, stage “p+1”). The output $Bo(y,2q+4)$ of the stage (ring “y”, stage “q+1”) is connected via the wire $Hop(2,2)$ to the input $Ui(x,2p+2)$ of the stage (ring “x”, stage “p”).

Ring “x” and ring “y” may or may not belong to the same block of the complete multi-stage hierarchical network $V_{Comb}(N_1, N_2, d, s)$. If ring “x” and ring “y” belong to the same block of the complete multi-stage hierarchical network $V_{Comb}(N_1, N_2, d, s)$, then the wires $Hop(1,1)$, $Hop(1,2)$, $Hop(2,1)$, and $Hop(2,2)$ are hereinafter called “internal hop wires”. For example if “x=2” and “y=3” and both the ring 2 and ring 3 belong to the same block (9,9) of 2D-grid **800**, then the wires $Hop(1,1)$, $Hop(1,2)$, $Hop(2,1)$, and $Hop(2,2)$ are “internal hop wires”.

If ring “x” and ring “y” belong to the different blocks of the complete multi-stage hierarchical network $V_{Comb}(N_1, N_2, d, s)$, then the wires $Hop(1,1)$, $Hop(1,2)$, $Hop(2,1)$, and $Hop(2,2)$ are hereinafter called “external hop wires”. The external hop wires $Hop(1,1)$, $Hop(1,2)$, $Hop(2,1)$, and $Hop(2,2)$ may be horizontal wires or vertical wires. The length of the external hop wires is manhattan distance between the corresponding blocks, hereinafter “hop length”. For example if ring “x” belongs to block (1,1) and ring “y” belongs to block (1,6) of 2D-grid **800** then the external hop wires are hereinafter called “horizontal external hop wires”. And the hop length of the horizontal hop wires $Hop(1,1)$, $Hop(1,2)$, $Hop(2,1)$, and $Hop(2,2)$ is given by $6-1=5$. Similarly if ring “x” and ring “y” belong to two blocks in the same horizontal row of 2D-grid **800**, then the wires $Hop(1,1)$, $Hop(1,2)$, $Hop(2,1)$, and $Hop(2,2)$ are horizontal external hop wires.

For example if ring “x” belongs to block (1,1) and ring “y” belongs to block (9,1) of 2D-grid **800** then the external hop wires are hereinafter called “vertical external hop wires”. And the hop length of the vertical hop wires $Hop(1,1)$, $Hop(1,2)$, $Hop(2,1)$, and $Hop(2,2)$ is given by $9-1=8$. Similarly if ring “x” and ring “y” belong to two blocks in the same vertical column of 2D-grid **800**, then the wires $Hop(1,1)$, $Hop(1,2)$, $Hop(2,1)$, and $Hop(2,2)$ are vertical external hop wires. External hop wires are typically horizontal or vertical according to the current invention.

Referring to diagram **300B** in FIG. **3B** illustrates all the connections between two arbitrary successive stages of a ring namely the stages (ring “x”, stage “p”) and (ring “x”, stage “p+1”) and two other arbitrary successive stages of any

other ring namely the stages (ring “y”, stage “q”) and (ring “y”, stage “q+1”), of the complete multi-stage hierarchical network $V_{Comb}(N_1, N_2, d, s)$.

The stage (ring “x”, stage “p”) consists of 8 inputs namely $Ri(x, 2p+1)$, $Ri(x, 2p+2)$, $Ui(x, 2p+1)$, $Ui(x, 2p+2)$, $J1$, $K1$, $L1$, and $M1$; and 4 outputs $Bo(x, 2p+1)$, $Bo(x, 2p+2)$, $Fo(x, 2p+1)$, and $Fo(x, 2p+2)$. The stage (ring “x”, stage “p”) also consists of eight 2:1 Muxes namely $R(x, 2p+1)$, $R(x, 2p+2)$, $F(x, 2p+1)$, $F(x, 2p+2)$, $U(x, 2p+1)$, $U(x, 2p+2)$, $B(x, 2p+1)$, and $B(x, 2p+2)$. The 2:1 Mux $R(x, 2p+1)$ has two inputs namely $Ri(x, 2p+1)$ and $J1$, and has one output $Ro(x, 2p+1)$. The 2:1 Mux $R(x, 2p+2)$ has two inputs namely $Ri(x, 2p+2)$ and $K1$, and has one output $Ro(x, 2p+2)$. The 2:1 Mux $F(x, 2p+1)$ has two inputs namely $Ro(x, 2p+1)$ and $Uo(x, 2p+2)$, and has one output $Fo(x, 2p+1)$. The 2:1 Mux $F(x, 2p+2)$ has two inputs namely $Ro(x, 2p+2)$ and $Uo(x, 2p+1)$, and has one output $Fo(x, 2p+2)$.

The 2:1 Mux $U(x, 2p+1)$ has two inputs namely $Ui(x, 2p+1)$ and $L1$, and has one output $Uo(x, 2p+1)$. The 2:1 Mux $U(x, 2p+2)$ has two inputs namely $Ui(x, 2p+2)$ and $M1$, and has one output $Uo(x, 2p+2)$. The 2:1 Mux $B(x, 2p+1)$ has two inputs namely $Uo(x, 2p+1)$ and $Ro(x, 2p+2)$, and has one output $Bo(x, 2p+1)$. The 2:1 Mux $B(x, 2p+2)$ has two inputs namely $Uo(x, 2p+2)$ and $Ro(x, 2p+1)$, and has one output $Bo(x, 2p+2)$.

The stage (ring “x”, stage “p+1”) consists of 8 inputs namely $Ri(x, 2p+3)$, $Ri(x, 2p+4)$, $Ui(x, 2p+3)$, $Ui(x, 2p+4)$, $J2$, $K2$, $L2$, and $M2$; and 4 outputs $Bo(x, 2p+3)$, $Bo(x, 2p+4)$, $Fo(x, 2p+3)$, and $Fo(x, 2p+4)$. The stage (ring “x”, stage “p+1”) also consists of eight 2:1 Muxes namely $R(x, 2p+3)$, $R(x, 2p+4)$, $F(x, 2p+3)$, $F(x, 2p+4)$, $U(x, 2p+3)$, $U(x, 2p+4)$, $B(x, 2p+3)$, and $B(x, 2p+4)$. The 2:1 Mux $R(x, 2p+3)$ has two inputs namely $Ri(x, 2p+3)$ and $J2$, and has one output $Ro(x, 2p+3)$. The 2:1 Mux $R(x, 2p+4)$ has two inputs namely $Ri(x, 2p+4)$ and $K2$, and has one output $Ro(x, 2p+4)$. The 2:1 Mux $F(x, 2p+3)$ has two inputs namely $Ro(x, 2p+3)$ and $Uo(x, 2p+4)$, and has one output $Fo(x, 2p+3)$. The 2:1 Mux $F(x, 2p+4)$ has two inputs namely $Ro(x, 2p+4)$ and $Uo(x, 2p+3)$, and has one output $Fo(x, 2p+4)$.

The 2:1 Mux $U(x, 2p+3)$ has two inputs namely $Ui(x, 2p+3)$ and $L2$, and has one output $Uo(x, 2p+3)$. The 2:1 Mux $U(x, 2p+4)$ has two inputs namely $Ui(x, 2p+4)$ and $M2$, and has one output $Uo(x, 2p+4)$. The 2:1 Mux $B(x, 2p+3)$ has two inputs namely $Uo(x, 2p+3)$ and $Ro(x, 2p+4)$, and has one output $Bo(x, 2p+3)$. The 2:1 Mux $B(x, 2p+4)$ has two inputs namely $Uo(x, 2p+4)$ and $Ro(x, 2p+3)$, and has one output $Bo(x, 2p+4)$.

The output $Fo(x, 2p+1)$ of the stage (ring “x”, stage “p”) is connected to the input $Ri(x, 2p+3)$ of the stage (ring “x”, stage “p+1”). And the output $Bo(x, 2p+3)$ of the stage (ring “x”, stage “p+1”) is connected to the input $Ui(x, 2p+1)$ of the stage (ring “x”, stage “p”).

The stage (ring “y”, stage “q”) consists of 8 inputs namely $Ri(y, 2q+1)$, $Ri(y, 2q+2)$, $Ui(y, 2q+1)$, $Ui(y, 2q+2)$, $J3$, $K3$, $L3$, and $M3$; and 4 outputs $Bo(y, 2q+1)$, $Bo(y, 2q+2)$, $Fo(y, 2q+1)$, and $Fo(y, 2q+2)$. The stage (ring “y”, stage “q”) also consists of eight 2:1 Muxes namely $R(y, 2q+1)$, $R(y, 2q+2)$, $F(y, 2q+1)$, $F(y, 2q+2)$, $U(y, 2q+1)$, $U(y, 2q+2)$, $B(y, 2q+1)$, and $B(y, 2q+2)$. The 2:1 Mux $R(y, 2q+1)$ has two inputs namely $Ri(y, 2q+1)$ and $J3$, and has one output $Ro(y, 2q+1)$. The 2:1 Mux $R(y, 2q+2)$ has two inputs namely $Ri(y, 2q+2)$ and $K3$, and has one output $Ro(y, 2q+2)$. The 2:1 Mux $F(y, 2q+1)$ has two inputs namely $Ro(y, 2q+1)$ and $Uo(y, 2q+2)$, and has one output $Fo(y, 2q+1)$. The 2:1 Mux $F(y, 2q+2)$ has two inputs namely $Ro(y, 2q+2)$ and $Uo(y, 2q+1)$ and has one output $Fo(y, 2q+2)$.

The 2:1 Mux $U(y, 2q+1)$ has two inputs namely $Ui(y, 2q+1)$ and $L3$, and has one output $Uo(y, 2q+1)$. The 2:1 Mux $U(y, 2q+2)$ has two inputs namely $Ui(y, 2q+2)$ and $M3$, and has one output $Uo(y, 2q+2)$. The 2:1 Mux $B(y, 2q+1)$ has two inputs namely $Uo(y, 2q+1)$ and $Ro(y, 2q+2)$, and has one output $Bo(y, 2q+1)$. The 2:1 Mux $B(y, 2q+2)$ has two inputs namely $Uo(y, 2q+2)$ and $Ro(y, 2q+1)$, and has one output $Bo(y, 2q+2)$.

The stage (ring “y”, stage “q+1”) consists of 8 inputs namely $Ri(y, 2q+3)$, $Ri(y, 2q+4)$, $Ui(y, 2q+3)$, $Ui(y, 2q+4)$, $J4$, $K4$, $L4$, and $M4$; and 4 outputs $Bo(y, 2q+3)$, $Bo(y, 2q+4)$, $Fo(y, 2q+3)$, and $Fo(y, 2q+4)$. The stage (ring “y”, stage “q+1”) also consists of eight 2:1 Muxes namely $R(y, 2q+3)$, $R(y, 2q+4)$, $F(y, 2q+3)$, $F(y, 2q+4)$, $U(y, 2q+3)$, $U(y, 2q+4)$, $B(y, 2q+3)$, and $B(y, 2q+4)$. The 2:1 Mux $R(y, 2q+3)$ has two inputs namely $Ri(y, 2q+3)$ and $J4$, and has one output $Ro(y, 2q+3)$. The 2:1 Mux $R(y, 2q+4)$ has two inputs namely $Ri(y, 2q+4)$ and $K4$, and has one output $Ro(y, 2q+4)$. The 2:1 Mux $F(y, 2q+3)$ has two inputs namely $Ro(y, 2q+3)$ and $Uo(y, 2q+4)$, and has one output $Fo(y, 2q+3)$. The 2:1 Mux $F(y, 2q+4)$ has two inputs namely $Ro(y, 2q+4)$ and $Uo(y, 2q+3)$, and has one output $Fo(y, 2q+4)$.

The 2:1 Mux $U(y, 2q+3)$ has two inputs namely $Ui(y, 2q+3)$ and $L4$, and has one output $Uo(y, 2q+3)$. The 2:1 Mux $U(y, 2q+4)$ has two inputs namely $Ui(y, 2q+4)$ and $M4$, and has one output $Uo(y, 2q+4)$. The 2:1 Mux $B(y, 2q+3)$ has two inputs namely $Uo(y, 2q+3)$ and $Ro(y, 2q+4)$, and has one output $Bo(y, 2q+3)$. The 2:1 Mux $B(y, 2q+4)$ has two inputs namely $Uo(y, 2q+4)$ and $Ro(y, 2q+3)$, and has one output $Bo(y, 2q+4)$.

The output $Fo(y, 2q+1)$ of the stage (ring “y”, stage “q”) is connected to the input $Ri(y, 2q+3)$ of the stage (ring “y”, stage “q+1”). And the output $Bo(y, 2q+3)$ of the stage (ring “y”, stage “q+1”) is connected to the input $Ui(y, 2q+1)$ of the stage (ring “y”, stage “q”).

The output $Fo(x, 2p+2)$ of the stage (ring “x”, stage “p”) is connected via the wire $Hop(1, 1)$ to the input $Ri(y, 2q+4)$ of the stage (ring “y”, stage “q+1”). The output $Bo(x, 2p+4)$ of the stage (ring “x”, stage “p+1”) is connected via the wire $Hop(1, 2)$ to the input $Ui(y, 2q+2)$ of the stage (ring “y”, stage “q”).

The output $Fo(y, 2q+2)$ of the stage (ring “y”, stage “q”) is connected via the wire $Hop(2, 1)$ to the input $Ri(x, 2p+4)$ of the stage (ring “x”, stage “p+1”). The output $Bo(y, 2q+4)$ of the stage (ring “y”, stage “q+1”) is connected via the wire $Hop(2, 2)$ to the input $Ui(x, 2p+2)$ of the stage (ring “x”, stage “p”).

In various embodiments, the inputs $J1$, $K1$, $L1$, and $M1$ are connected from any of the outputs of any other stages of any ring of any block of the multi-stage hierarchical network $V_{Comb}(N_1, N_2, d, s)$. Similarly the inputs $J2$, $K2$, $L2$, and $M2$ are connected from any of the outputs of any other stages of any ring of any block of the multi-stage hierarchical network $V_{Comb}(N_1, N_2, d, s)$. Similarly the inputs $J3$, $K3$, $L3$, and $M3$ are connected from any of the outputs of any other stages of any ring of any block of the multi-stage hierarchical network $V_{Comb}(N_1, N_2, d, s)$. Finally the inputs $J4$, $K4$, $L4$, and $M4$ are connected from any of the outputs of any other stages of any ring of any block of the multi-stage hierarchical network $V_{Comb}(N_1, N_2, d, s)$.

Referring to diagram 400 in FIG. 4, illustrates all the connections between two arbitrary successive stages of a ring namely the stages (ring “x”, stage “p”) and (ring “x”, stage “p+1”) and two other arbitrary successive stages of any other ring namely the stages (ring “y”, stage “q”) and (ring “y”, stage “q+1”), of the complete multi-stage hierarchical network $V_{Comb}(N_1, N_2, d, s)$.

The stage (ring “x”, stage “p”) consists of 4 inputs namely $F_i(x,2p+1)$, $F_i(x,2p+2)$, $U_i(x,2p+1)$, and $U_i(x,2p+2)$; and 4 outputs $B_o(x,2p+1)$, $B_o(x,2p+2)$, $F_o(x,2p+1)$, and $F_o(x,2p+2)$. The stage (ring “x”, stage “p”) also consists of six 2:1 Muxes namely $F(x,2p+1)$, $F(x,2p+2)$, $U(x,2p+1)$, $U(x,2p+2)$, $B(x,2p+1)$, and $B(x,2p+2)$. The 2:1 Mux $F(x,2p+1)$ has two inputs namely $F_i(x,2p+1)$ and $F_i(x,2p+2)$ and has one output $F_o(x,2p+1)$. The 2:1 Mux $F(x,2p+2)$ has two inputs namely $F_i(x,2p+1)$ and $F_i(x,2p+2)$ and has one output $F_o(x,2p+2)$.

The 2:1 Mux $U(x,2p+1)$ has two inputs namely $U_i(x,2p+1)$ and $F_o(x,2p+1)$ and has one output $U_o(x,2p+1)$. The 2:1 Mux $U(x,2p+2)$ has two inputs namely $U_i(x,2p+2)$ and $F_o(x,2p+2)$ and has one output $U_o(x,2p+2)$. The 2:1 Mux $B(x,2p+1)$ has two inputs namely $U_o(x,2p+1)$ and $U_o(x,2p+2)$ and has one output $B_o(x,2p+1)$. The 2:1 Mux $B(x,2p+2)$ has two inputs namely $U_o(x,2p+1)$ and $U_o(x,2p+2)$ and has one output $B_o(x,2p+2)$.

The stage (ring “x”, stage “p+1”) consists of 4 inputs namely $F_i(x,2p+3)$, $F_i(x,2p+4)$, $U_i(x,2p+3)$, and $U_i(x,2p+4)$; and 4 outputs $B_o(x,2p+3)$, $B_o(x,2p+4)$, $F_o(x,2p+3)$, and $F_o(x,2p+4)$. The stage (ring “x”, stage “p+1”) also consists of six 2:1 Muxes namely $F(x,2p+3)$, $F(x,2p+4)$, $U(x,2p+3)$, $U(x,2p+4)$, $B(x,2p+3)$, and $B(x,2p+4)$. The 2:1 Mux $F(x,2p+3)$ has two inputs namely $F_i(x,2p+3)$ and $F_i(x,2p+4)$ and has one output $F_o(x,2p+3)$. The 2:1 Mux $F(x,2p+4)$ has two inputs namely $F_i(x,2p+3)$ and $F_i(x,2p+4)$ and has one output $F_o(x,2p+4)$.

The 2:1 Mux $U(x,2p+3)$ has two inputs namely $U_i(x,2p+3)$ and $F_o(x,2p+3)$ and has one output $U_o(x,2p+3)$. The 2:1 Mux $U(x,2p+4)$ has two inputs namely $U_i(x,2p+4)$ and $F_o(x,2p+4)$ and has one output $U_o(x,2p+4)$. The 2:1 Mux $B(x,2p+3)$ has two inputs namely $U_o(x,2p+3)$ and $U_o(x,2p+4)$ and has one output $B_o(x,2p+3)$. The 2:1 Mux $B(x,2p+4)$ has two inputs namely $U_o(x,2p+3)$ and $U_o(x,2p+4)$ and has one output $B_o(x,2p+4)$.

The output $F_o(x,2p+1)$ of the stage (ring “x”, stage “p”) is connected to the input $F_i(x,2p+3)$ of the stage (ring “x”, stage “p+1”). And the output $B_o(x,2p+3)$ of the stage (ring “x”, stage “p+1”) is connected to the input $U_i(x,2p+1)$ of the stage (ring “x”, stage “p”).

The stage (ring “y”, stage “q”) consists of 4 inputs namely $F_i(y,2q+1)$, $F_i(y,2q+2)$, $U_i(y,2q+1)$, and $U_i(y,2q+2)$; and 4 outputs $B_o(y,2q+1)$, $B_o(y,2q+2)$, $F_o(y,2q+1)$, and $F_o(y,2q+2)$. The stage (ring “y”, stage “q”) also consists of six 2:1 Muxes namely $F(y,2q+1)$, $F(y,2q+2)$, $U(y,2q+1)$, $U(y,2q+2)$, $B(y,2q+1)$, and $B(y,2q+2)$. The 2:1 Mux $F(y,2q+1)$ has two inputs namely $F_i(y,2q+1)$ and $F_i(y,2q+2)$ and has one output $F_o(y,2q+1)$. The 2:1 Mux $F(y,2q+2)$ has two inputs namely $F_i(y,2q+1)$ and $F_i(y,2q+2)$ and has one output $F_o(y,2q+2)$.

The 2:1 Mux $U(y,2q+1)$ has two inputs namely $U_i(y,2q+1)$ and $F_o(y,2q+1)$ and has one output $U_o(y,2q+1)$. The 2:1 Mux $U(y,2q+2)$ has two inputs namely $U_i(y,2q+2)$ and $F_o(y,2q+2)$ and has one output $U_o(y,2q+2)$. The 2:1 Mux $B(y,2q+1)$ has two inputs namely $U_o(y,2q+1)$ and $U_o(y,2q+2)$ and has one output $B_o(y,2q+1)$. The 2:1 Mux $B(y,2q+2)$ has two inputs namely $U_o(y,2q+1)$ and $U_o(y,2q+2)$ and has one output $B_o(y,2q+2)$.

The stage (ring “y”, stage “q+1”) consists of 4 inputs namely $F_i(y,2q+3)$, $F_i(y,2q+4)$, $U_i(y,2q+3)$, and $U_i(y,2q+4)$; and 4 outputs $B_o(y,2q+3)$, $B_o(y,2q+4)$, $F_o(y,2q+3)$, and $F_o(y,2q+4)$. The stage (ring “y”, stage “q+1”) also consists of six 2:1 Muxes namely $F(y,2q+3)$, $F(y,2q+4)$, $U(y,2q+3)$, $U(y,2q+4)$, $B(y,2q+3)$, and $B(y,2q+4)$. The 2:1 Mux $F(y,2q+3)$ has two inputs namely $F_i(y,2q+3)$ and $F_i(y,2q+4)$ and has

one output $F_o(y,2q+3)$. The 2:1 Mux $F(y,2q+4)$ has two inputs namely $F_i(y,2q+3)$ and $F_i(y,2q+4)$ and has one output $F_o(y,2q+4)$.

The 2:1 Mux $U(y,2q+3)$ has two inputs namely $U_i(y,2q+3)$ and $F_o(y,2q+3)$ and has one output $U_o(y,2q+3)$. The 2:1 Mux $U(y,2q+4)$ has two inputs namely $U_i(y,2q+4)$ and $F_o(y,2q+4)$ and has one output $U_o(y,2q+4)$. The 2:1 Mux $B(y,2q+3)$ has two inputs namely $U_o(y,2q+3)$ and $U_o(y,2q+4)$ and has one output $B_o(y,2q+3)$. The 2:1 Mux $B(y,2q+4)$ has two inputs namely $U_o(y,2q+3)$ and $U_o(y,2q+4)$ and has one output $B_o(y,2q+4)$.

The output $F_o(y,2q+1)$ of the stage (ring “y”, stage “q”) is connected to the input $F_i(y,2q+3)$ of the stage (ring “y”, stage “q+1”). And the output $B_o(y,2q+3)$ of the stage (ring “y”, stage “q+1”) is connected to the input $U_i(y,2q+1)$ of the stage (ring “y”, stage “q”).

The output $F_o(x,2p+2)$ of the stage (ring “x”, stage “p”) is connected via the wire $Hop(1,1)$ to the input $F_i(y,2q+4)$ of the stage (ring “y”, stage “q+1”). The output $B_o(x,2p+4)$ of the stage (ring “x”, stage “p+1”) is connected via the wire $Hop(1,2)$ to the input $U_i(y,2q+2)$ of the stage (ring “y”, stage “q”).

The output $F_o(y,2q+2)$ of the stage (ring “y”, stage “q”) is connected via the wire $Hop(2,1)$ to the input $F_i(x,2p+4)$ of the stage (ring “x”, stage “p+1”). The output $B_o(y,2q+4)$ of the stage (ring “y”, stage “q+1”) is connected via the wire $Hop(2,2)$ to the input $U_i(x,2p+2)$ of the stage (ring “x”, stage “p”).

Referring to diagram 500 in FIG. 5, illustrates all the connections between two arbitrary successive stages of a ring namely the stages (ring “x”, stage “p”) and (ring “x”, stage “p+1”) and two other arbitrary successive stages of any other ring namely the stages (ring “y”, stage “q”) and (ring “y”, stage “q+1”), of the complete multi-stage hierarchical network $V_{Comb}(N_1, N_2, d, s)$.

The stage (ring “x”, stage “p”) consists of 4 inputs namely $F_i(x,2p+1)$, $F_i(x,2p+2)$, $U_i(x,2p+1)$, and $U_i(x,2p+2)$; and 4 outputs $B_o(x,2p+1)$, $B_o(x,2p+2)$, $F_o(x,2p+1)$, and $F_o(x,2p+2)$. The stage (ring “x”, stage “p”) also consists of six 2:1 Muxes namely $F(x,2p+1)$, $F(x,2p+2)$, $U(x,2p+1)$, $U(x,2p+2)$, $B(x,2p+1)$, and $B(x,2p+2)$. The 2:1 Mux $F(x,2p+1)$ has two inputs namely $F_i(x,2p+1)$ and $F_i(x,2p+2)$ and has one output $F_o(x,2p+1)$. The 2:1 Mux $F(x,2p+2)$ has two inputs namely $F_i(x,2p+1)$ and $F_i(x,2p+2)$ and has one output $F_o(x,2p+2)$.

The 2:1 Mux $U(x,2p+1)$ has two inputs namely $U_i(x,2p+1)$ and $F_o(x,2p+1)$ and has one output $U_o(x,2p+1)$. The 2:1 Mux $U(x,2p+2)$ has two inputs namely $U_i(x,2p+2)$ and $F_o(x,2p+2)$ and has one output $U_o(x,2p+2)$. The 2:1 Mux $B(x,2p+1)$ has two inputs namely $U_o(x,2p+1)$ and $U_o(x,2p+2)$ and has one output $B_o(x,2p+1)$. The 2:1 Mux $B(x,2p+2)$ has two inputs namely $U_o(x,2p+1)$ and $U_o(x,2p+2)$ and has one output $B_o(x,2p+2)$.

The stage (ring “x”, stage “p+1”) consists of 2 inputs namely $F_i(x,2p+3)$, $F_i(x,2p+4)$; and 2 outputs $F_o(x,2p+3)$, and $F_o(x,2p+4)$. The stage (ring “x”, stage “p+1”) also consists of two 2:1 Muxes namely $F(x,2p+3)$ and $F(x,2p+4)$. The 2:1 Mux $F(x,2p+3)$ has two inputs namely $F_i(x,2p+3)$ and $F_i(x,2p+4)$ and has one output $F_o(x,2p+3)$. The 2:1 Mux $F(x,2p+4)$ has two inputs namely $F_i(x,2p+3)$ and $F_i(x,2p+4)$ and has one output $F_o(x,2p+4)$.

The output $F_o(x,2p+1)$ of the stage (ring “x”, stage “p”) is connected to the input $F_i(x,2p+3)$ of the stage (ring “x”, stage “p+1”). And the output $F_o(x,2p+3)$ of the stage (ring “x”, stage “p+1”) is connected to the input $U_i(x,2p+1)$ of the stage (ring “x”, stage “p”).

The stage (ring “y”, stage “q”) consists of 4 inputs namely $F_i(y,2q+1)$, $F_i(y,2q+2)$, $U_i(y,2q+1)$, and $U_i(y,2q+2)$; and 4 outputs $B_o(y,2q+1)$, $B_o(y,2q+2)$, $F_o(y,2q+1)$, and $F_o(y,2q+2)$. The stage (ring “y”, stage “q”) also consists of six 2:1 Muxes namely $F(y,2q+1)$, $F(y,2q+2)$, $U(y,2q+1)$, $U(y,2q+2)$, $B(y,2q+1)$, and $B(y,2q+2)$. The 2:1 Mux $F(y,2q+1)$ has two inputs namely $F_i(y,2q+1)$ and $F_i(y,2q+2)$ and has one output $F_o(y,2q+1)$. The 2:1 Mux $F(y,2q+2)$ has two inputs namely $F_i(y,2q+1)$ and $F_i(y,2q+2)$ and has one output $F_o(y,2q+2)$.

The 2:1 Mux $U(y,2q+1)$ has two inputs namely $U_i(y,2q+1)$ and $F_o(y,2q+1)$ and has one output $U_o(y,2q+1)$. The 2:1 Mux $U(y,2q+2)$ has two inputs namely $U_i(y,2q+2)$ and $F_o(y,2q+2)$ and has one output $U_o(y,2q+2)$. The 2:1 Mux $B(y,2q+1)$ has two inputs namely $U_o(y,2q+1)$ and $U_o(y,2q+2)$ and has one output $B_o(y,2q+1)$. The 2:1 Mux $B(y,2q+2)$ has two inputs namely $U_o(y,2q+1)$ and $U_o(y,2q+2)$ and has one output $B_o(y,2q+2)$.

The stage (ring “y”, stage “q+1”) consists of 4 inputs namely $F_i(y,2q+3)$, $F_i(y,2q+4)$, $U_i(y,2q+3)$, and $U_i(y,2q+4)$; and 4 outputs $B_o(y,2q+3)$, $B_o(y,2q+4)$, $F_o(y,2q+3)$, and $F_o(y,2q+4)$. The stage (ring “y”, stage “q+1”) also consists of six 2:1 Muxes namely $F(y,2q+3)$, $F(y,2q+4)$, $U(y,2q+3)$, $U(y,2q+4)$, $B(y,2q+3)$, and $B(y,2q+4)$. The 2:1 Mux $F(y,2q+3)$ has two inputs namely $F_i(y,2q+3)$ and $F_i(y,2q+4)$ and has one output $F_o(y,2q+3)$. The 2:1 Mux $F(y,2q+4)$ has two inputs namely $F_i(y,2q+3)$ and $F_i(y,2q+4)$ and has one output $F_o(y,2q+4)$.

The 2:1 Mux $U(y,2q+3)$ has two inputs namely $U_i(y,2q+3)$ and $F_o(y,2q+3)$ and has one output $U_o(y,2q+3)$. The 2:1 Mux $U(y,2q+4)$ has two inputs namely $U_i(y,2q+4)$ and $F_o(y,2q+4)$ and has one output $U_o(y,2q+4)$. The 2:1 Mux $B(y,2q+3)$ has two inputs namely $U_o(y,2q+3)$ and $U_o(y,2q+4)$ and has one output $B_o(y,2q+3)$. The 2:1 Mux $B(y,2q+4)$ has two inputs namely $U_o(y,2q+3)$ and $U_o(y,2q+4)$ and has one output $B_o(y,2q+4)$.

The output $F_o(y,2q+1)$ of the stage (ring “y”, stage “q”) is connected to the input $F_i(y,2q+3)$ of the stage (ring “y”, stage “q+1”). And the output $B_o(y,2q+3)$ of the stage (ring “y”, stage “q+1”) is connected to the input $U_i(y,2q+1)$ of the stage (ring “y”, stage “q”).

The output $F_o(x,2p+2)$ of the stage (ring “x”, stage “p”) is connected via the wire Hop(1,1) to the input $F_i(y,2q+4)$ of the stage (ring “y”, stage “q+1”). The output $F_o(x,2p+4)$ of the stage (ring “x”, stage “p+1”) is connected via the wire Hop(1,2) to the input $U_i(y,2q+2)$ of the stage (ring “y”, stage “q”).

The output $F_o(y,2q+2)$ of the stage (ring “y”, stage “q”) is connected via the wire Hop(2,1) to the input $F_i(x,2p+4)$ of the stage (ring “x”, stage “p+1”). The output $B_o(y,2q+4)$ of the stage (ring “y”, stage “q+1”) is connected via the wire Hop(2,2) to the input $U_i(x,2p+2)$ of the stage (ring “x”, stage “p”).

Referring to diagram 600 in FIG. 6, illustrates all the connections between root stage of a ring namely the stage (ring “x”, stage “p”) and two other arbitrary successive stages of any other ring namely the stages (ring “y”, stage “q”) and (ring “y”, stage “q+1”), of the complete multi-stage hierarchical network $V_{Comb}(N_1, N_2, d, s)$.

The stage (ring “x”, stage “p”) consists of 4 inputs namely $F_i(x,2p+1)$, $F_i(x,2p+2)$, $U_i(x,2p+1)$, and $U_i(x,2p+2)$; and 4 outputs $B_o(x,2p+1)$, $B_o(x,2p+2)$, $F_o(x,2p+1)$, and $F_o(x,2p+2)$. The stage (ring “x”, stage “p”) also consists of six 2:1 Muxes namely $F(x,2p+1)$, $F(x,2p+2)$, $U(x,2p+1)$, $U(x,2p+2)$, $B(x,2p+1)$, and $B(x,2p+2)$. The 2:1 Mux $F(x,2p+1)$ has two inputs namely $F_i(x,2p+1)$ and $F_i(x,2p+2)$ and has one

output $F_o(x,2p+1)$. The 2:1 Mux $F(x,2p+2)$ has two inputs namely $F_i(x,2p+1)$ and $F_i(x,2p+2)$ and has one output $F_o(x,2p+2)$.

The 2:1 Mux $U(x,2p+1)$ has two inputs namely $U_i(x,2p+1)$ and $F_o(x,2p+1)$ and has one output $U_o(x,2p+1)$. The 2:1 Mux $U(x,2p+2)$ has two inputs namely $U_i(x,2p+2)$ and $F_o(x,2p+2)$ and has one output $U_o(x,2p+2)$. The 2:1 Mux $B(x,2p+1)$ has two inputs namely $U_o(x,2p+1)$ and $U_o(x,2p+2)$ and has one output $B_o(x,2p+1)$. The 2:1 Mux $B(x,2p+2)$ has two inputs namely $U_o(x,2p+1)$ and $U_o(x,2p+2)$ and has one output $B_o(x,2p+2)$.

The stage (ring “y”, stage “q”) consists of 4 inputs namely $F_i(y,2q+1)$, $F_i(y,2q+2)$, $U_i(y,2q+1)$, and $U_i(y,2q+2)$; and 4 outputs $B_o(y,2q+1)$, $B_o(y,2q+2)$, $F_o(y,2q+1)$, and $F_o(y,2q+2)$. The stage (ring “y”, stage “q”) also consists of six 2:1 Muxes namely $F(y,2q+1)$, $F(y,2q+2)$, $U(y,2q+1)$, $U(y,2q+2)$, $B(y,2q+1)$, and $B(y,2q+2)$. The 2:1 Mux $F(y,2q+1)$ has two inputs namely $F_i(y,2q+1)$ and $F_i(y,2q+2)$ and has one output $F_o(y,2q+1)$. The 2:1 Mux $F(y,2q+2)$ has two inputs namely $F_i(y,2q+1)$ and $F_i(y,2q+2)$ and has one output $F_o(y,2q+2)$.

The 2:1 Mux $U(y,2q+1)$ has two inputs namely $U_i(y,2q+1)$ and $F_o(y,2q+1)$ and has one output $U_o(y,2q+1)$. The 2:1 Mux $U(y,2q+2)$ has two inputs namely $U_i(y,2q+2)$ and $F_o(y,2q+2)$ and has one output $U_o(y,2q+2)$. The 2:1 Mux $B(y,2q+1)$ has two inputs namely $U_o(y,2q+1)$ and $U_o(y,2q+2)$ and has one output $B_o(y,2q+1)$. The 2:1 Mux $B(y,2q+2)$ has two inputs namely $U_o(y,2q+1)$ and $U_o(y,2q+2)$ and has one output $B_o(y,2q+2)$.

The stage (ring “y”, stage “q+1”) consists of 4 inputs namely $F_i(y,2q+3)$, $F_i(y,2q+4)$, $U_i(y,2q+3)$, and $U_i(y,2q+4)$; and 4 outputs $B_o(y,2q+3)$, $B_o(y,2q+4)$, $F_o(y,2q+3)$, and $F_o(y,2q+4)$. The stage (ring “y”, stage “q+1”) also consists of six 2:1 Muxes namely $F(y,2q+3)$, $F(y,2q+4)$, $U(y,2q+3)$, $U(y,2q+4)$, $B(y,2q+3)$, and $B(y,2q+4)$. The 2:1 Mux $F(y,2q+3)$ has two inputs namely $F_i(y,2q+3)$ and $F_i(y,2q+4)$ and has one output $F_o(y,2q+3)$. The 2:1 Mux $F(y,2q+4)$ has two inputs namely $F_i(y,2q+3)$ and $F_i(y,2q+4)$ and has one output $F_o(y,2q+4)$.

The 2:1 Mux $U(y,2q+3)$ has two inputs namely $U_i(y,2q+3)$ and $F_o(y,2q+3)$ and has one output $U_o(y,2q+3)$. The 2:1 Mux $U(y,2q+4)$ has two inputs namely $U_i(y,2q+4)$ and $F_o(y,2q+4)$ and has one output $U_o(y,2q+4)$. The 2:1 Mux $B(y,2q+3)$ has two inputs namely $U_o(y,2q+3)$ and $U_o(y,2q+4)$ and has one output $B_o(y,2q+3)$. The 2:1 Mux $B(y,2q+4)$ has two inputs namely $U_o(y,2q+3)$ and $U_o(y,2q+4)$ and has one output $B_o(y,2q+4)$.

The output $F_o(y,2q+1)$ of the stage (ring “y”, stage “q”) is connected to the input $F_i(y,2q+3)$ of the stage (ring “y”, stage “q+1”). And the output $B_o(y,2q+3)$ of the stage (ring “y”, stage “q+1”) is connected to the input $U_i(y,2q+1)$ of the stage (ring “y”, stage “q”).

The output $F_o(x,2p+1)$ of the stage (ring “x”, stage “p”) is connected via the wire Hop(1,2) to the input $U_i(y,2q+2)$ of the stage (ring “y”, stage “q”). The output $F_o(x,2p+2)$ of the stage (ring “x”, stage “p”) is connected via the wire Hop(1,1) to the input $F_i(y,2q+4)$ of the stage (ring “y”, stage “q+1”).

The output $F_o(y,2q+2)$ of the stage (ring “y”, stage “q”) is connected via the wire Hop(2,1) to the input $U_i(x,2p+1)$ of the stage (ring “x”, stage “p”). The output $B_o(y,2q+4)$ of the stage (ring “y”, stage “q+1”) is connected via the wire Hop(2,2) to the input $U_i(x,2p+2)$ of the stage (ring “x”, stage “p”).

Just like in diagram 300A of FIG. 3A, in diagram 300B of FIG. 3B, in diagram 400 of FIG. 4, diagram 500 of FIG. 5, and in diagram 6 of FIG. 6, the wires Hop(1,1), Hop(1,2),

Hop(2,1), and Hop(2,2) are either internal hop wires or horizontal external hop wires or vertical external hop wires.

Referring to diagram 700 in FIG. 7, illustrates, in one embodiment, the hop wire connections chart of a partial multi-stage hierarchical network $V_{Comb}(N_1, N_2, d, s)$ 100A or a partial multi-stage hierarchical network $V_{Comb}(N_1, N_2, d, s)$ 100B, with $m=6$ and $n=7$. The hop wire connections chart shows two rings namely ring 1 and ring 2. And there are $m+1=7$ stages in ring 1 and $n+1=8$ stages in ring 2.

The hop wire connections chart 700 illustrates how the hop wires are connected between any two successive stages of all the rings corresponding to a block of 2D-grid 800. "Lx" denotes an internal hop wire connection, where symbol "L" denotes internal hop wire and "x" is an integer. For example "L1" between the stages (ring 1, stage 0) and (ring 1, stage 1) denotes that the corresponding hop wires Hop(1,1), Hop(1,2), Hop(2,1), and Hop(2,2) are connected to two successive stages of another ring in the same block or alternatively hop wires Hop(1,1), Hop(1,2), Hop(2,1), and Hop(2,2) are internal hop wires. Since there is also "L1" between the stages (ring 2, stage 0) and (ring 2, stage 1), there are internal hop wire connections Hop(1,1), Hop(1,2), Hop(2,1), and Hop(2,2) connected between the stages (ring 1, stage 0) and (ring 1, stage 1) and the stages (ring 2, stage 0) and (ring 2, stage 1). Hence there can be only two "L1" labels in the hop wire connection chart 700.

Similarly there are two "L2" labels in the hop wire connections chart 700. Since the label "L2" is given between the stages (ring 1, stage 5) and (ring 1, stage 6) and also the label "L2" is given between the stages (ring 2, stage 3) and (ring 2, stage 4), there are corresponding internal hop wire connections Hop(1,1), Hop(1,2), Hop(2,1), and Hop(2,2) connected between the stages (ring 1, stage 5) and (ring 1, stage 6) and the stages (ring 2, stage 3) and (ring 2, stage 4).

"Vx" denotes an external vertical hop wire, where symbol "V" denotes vertical external hop wire connections from blocks of the topmost row of 2D-grid 800 (i.e., row of blocks consisting of block (1,1), block (1,2), . . . , and block (1,10)) to the same corresponding stages of the same numbered ring of another block that is directly down south, with "x" vertical hop length, where "x" is a positive integer. For example "V1" between the stages (ring 1, stage 1) and (ring 1, stage 2) denote that from block (1,1) of 2D-grid 800 to another block directly below it, which is block (2,1), since "V1" denotes hop length of 1, there are external hop wire connections Hop(1,1), Hop(1,2), Hop(2,1), and Hop(2,2) from (ring 1, stage 1) and (ring 1, stage 2) of block (1,1) to (ring 1, stage 1) and (ring 1, stage 2) of block (2,1). It also means there are external hop wire connections Hop(1,1), Hop(1,2), Hop(2,1), and Hop(2,2) from (ring 1, stage 1) and (ring 1, stage 2) of block (3,1) to (ring 1, stage 1) and (ring 1, stage 2) of block (4,1). This pattern continues and finally there are external hop wire connections Hop(1,1), Hop(1,2), Hop(2,1), and Hop(2,2) from (ring 1, stage 1) and (ring 1, stage 2) of block (9,1) to (ring 1, stage 1) and (ring 1, stage 2) of block (10,1). The same pattern continues for all the columns starting from the block in the topmost row of each column.

Similarly "V3" between the stages (ring 2, stage 1) and (ring 2, stage 2) denote that from block (1,1) of 2D-grid 800 to another block below it and at a hop length of 3 which is block (4,1), there are external hop wire connections Hop(1,1), Hop(1,2), Hop(2,1), and Hop(2,2) from (ring 2, stage 1) and (ring 2, stage 2) of block (1,1) to (ring 2, stage 1) and (ring 2, stage 2) of block (4,1). It also means there are external hop wire connections Hop(1,1), Hop(1,2), Hop(2,1), and Hop(2,2) from (ring 2, stage 1) and (ring 2, stage 2)

of block (2,1) to (ring 2, stage 1) and (ring 2, stage 2) of block (5,1). This pattern continues and finally there are external hop wire connections Hop(1,1), Hop(1,2), Hop(2,1), and Hop(2,2) from (ring 2, stage 1) and (ring 2, stage 2) of block (7,1) to (ring 2, stage 1) and (ring 2, stage 2) of block (10,1). The same pattern continues for all the columns starting from the block in the topmost row of each column.

If there is no block that is directly below a block with hop length equal to 3 then there is no vertical external hop wire connections is given corresponding to those two successive stages of the blocks. For example block (8,1) does not have any block that is directly below and with hop length equal to 3 then none of the vertical external hop wires are connected from (ring 2, stage 1) and (ring 2, stage 2) of block (8,1). Similarly from (ring 2, stage 1) and (ring 2, stage 2) of block (9,1) and from (ring 2, stage 1) and (ring 2, stage 2) of block (10,1), none of the vertical external hop wires are connected. Similarly vertical external hop wires are connected corresponding to "V5", "V7" etc., labels given in the hop wire connections chart 700.

"Ux" denotes an external vertical hop wire, where symbol "U" denotes vertical external hop wire connections starting from blocks that are "x" hop length below the topmost row of 2D-grid 800 (i.e., row of blocks consisting of block (1+x,1), block (1+x,2), . . . , and block (1+x,10)) to the same corresponding stages of the same numbered ring of another block that is directly down below, with "x" vertical hop length, where "x" is a positive integer. For example "U1" between the stages (ring 1, stage 2) and (ring 1, stage 3) denote that from block (2,1) of 2D-grid 800 to another block directly below it, which is block (3,1), since "U1" denotes hop length of 1, there are external hop wire connections Hop(1,1), Hop(1,2), Hop(2,1), and Hop(2,2) from (ring 1, stage 2) and (ring 1, stage 3) of block (2,1) to (ring 1, stage 2) and (ring 1, stage 3) of block (3,1). It also means there are external hop wire connections Hop(1,1), Hop(1,2), Hop(2,1), and Hop(2,2) from (ring 1, stage 2) and (ring 1, stage 3) of block (4,1) to (ring 1, stage 2) and (ring 1, stage 3) of block (5,1). This pattern continues and finally there are external hop wire connections Hop(1,1), Hop(1,2), Hop(2,1), and Hop(2,2) from (ring 1, stage 2) and (ring 1, stage 3) of block (8,1) to (ring 1, stage 2) and (ring 1, stage 3) of block (9,1). The same pattern continues for all the columns starting from the block in the topmost row of each column.

If there is no block that is directly below a block with hop length equal to 1 then no vertical external hop wire connections is given corresponding to those two successive stages of the blocks. For example block (10,1) does not have any block that is directly below and with hop length equal to 1 then none of the vertical external hop wires are connected from (ring 1, stage 2) and (ring 1, stage 3) of block (10,1). Similarly for all the blocks in each column from the topmost row up to the row "x", no vertical external hop wires are connected to the corresponding (ring 1, stage 2) and (ring 1, stage 3).

Similarly "U3" between the stages (ring 2, stage 2) and (ring 2, stage 3) denote that starting from blocks that are 3 hop length below the topmost row of 2D-grid 800 (i.e., row of blocks consisting of block (4,1), block (4,2), . . . , and block (4,10)) to the same corresponding stages of the same numbered ring of another block that is directly down below, with vertical hop length of 3, there are external hop wire connections Hop(1,1), Hop(1,2), Hop(2,1), and Hop(2,2) connected. For example from block (4,1) of 2D-grid 800 to another block below it and at a hop length of 3 which is block (7,1), there are external hop wire connections Hop(1,1), Hop(1,2), Hop(2,1), and Hop(2,2) from (ring 2, stage 2)

and (ring 2, stage 3) of block (4,1) to (ring 2, stage 1) and (ring 2, stage 2) of block (7,1). It also means there are external hop wire connections Hop(1,1), Hop(1,2), Hop(2,1), and Hop(2,2) from (ring 2, stage 2) and (ring 2, stage 3) of block (5,1) to (ring 2, stage 2) and (ring 2, stage 3) of block (8,1). This pattern continues and finally there are external hop wire connections Hop(1,1), Hop(1,2), Hop(2,1), and Hop(2,2) from (ring 2, stage 2) and (ring 2, stage 3) of block (7,1) to (ring 2, stage 2) and (ring 2, stage 3) of block (10,1). The same pattern continues for all the columns starting from the block in the topmost row of each column.

If there is no block that is directly below a block with hop length equal to 3 then no vertical external hop wire connections is given corresponding to those two successive stages of the blocks. For example block (8,1) does not have any block that is directly below and with hop length equal to 3 then none of the vertical external hop wires are connected from (ring 2, stage 2) and (ring 2, stage 3) of block (8,1). Similarly from (ring 2, stage 2) and (ring 2, stage 3) of block (9,1) and from (ring 2, stage 2) and (ring 2, stage 3) of block (10,1), none of the vertical external hop wires are connected. Similarly vertical external hop wires are connected corresponding to "U5", "U7" etc. labels given in the hop wire connections chart 700.

"Hx" denotes an external horizontal hop wire, where symbol "H" denotes horizontal external hop wire connections from blocks of the leftmost column of 2D-grid 800 (i.e., column of blocks consisting of block (1,1), block (2,1), . . . , and block (10,1)) to the same corresponding stages of the same numbered ring of another block that is directly to the right, with "x" horizontal hop length, where "x" is a positive integer. For example "H1" between the stages (ring 1, stage 3) and (ring 1, stage 4) denote that from block (1,1) of 2D-grid 800 to another block directly to the right, which is block (1,2), since "H1" denotes hop length of 1, there are external hop wire connections Hop(1,1), Hop(1,2), Hop(2,1), and Hop(2,2) from (ring 1, stage 3) and (ring 1, stage 4) of block (1,1) to (ring 1, stage 3) and (ring 1, stage 4) of block (1,2). It also means there are external hop wire connections Hop(1,1), Hop(1,2), Hop(2,1), and Hop(2,2) from (ring 1, stage 3) and (ring 1, stage 4) of block (1,3) to (ring 1, stage 3) and (ring 1, stage 4) of block (1,4). This pattern continues and finally there are external hop wire connections Hop(1,1), Hop(1,2), Hop(2,1), and Hop(2,2) from (ring 1, stage 3) and (ring 1, stage 4) of block (9,1) to (ring 1, stage 3) and (ring 1, stage 4) of block (10,1). The same pattern continues for all the rows starting from the block in the leftmost block of each row.

Similarly "H3" between the stages (ring 2, stage 4) and (ring 2, stage 5) denote that from block (1,1) of 2D-grid 800 to another block to the right and at a hop length of 3 which is block (1,4), there are external hop wire connections Hop(1,1), Hop(1,2), Hop(2,1), and Hop(2,2) from (ring 2, stage 4) and (ring 2, stage 5) of block (1,1) to (ring 2, stage 4) and (ring 2, stage 5) of block (1,4). It also means there are external hop wire connections Hop(1,1), Hop(1,2), Hop(2,1), and Hop(2,2) from (ring 2, stage 4) and (ring 2, stage 5) of block (1,2) to (ring 2, stage 4) and (ring 2, stage 5) of block (1,5). This pattern continues and finally there are external hop wire connections Hop(1,1), Hop(1,2), Hop(2,1), and Hop(2,2) from (ring 2, stage 4) and (ring 2, stage 5) of block (1,7) to (ring 2, stage 4) and (ring 2, stage 5) of block (1,10). The same pattern continues for all the columns starting from the block in the leftmost column of each row.

If there is no block that is directly to the right with hop length equal to 3 then there is no horizontal external hop wire connections is given corresponding to those two suc-

cessive stages of the blocks. For example block (1,8) does not have any block that is directly to the right and with hop length equal to 3 then none of the horizontal external hop wires are connected from (ring 2, stage 4) and (ring 2, stage 5) of block (1,8). Similarly from (ring 2, stage 4) and (ring 2, stage 5) of block (1,9) and from (ring 2, stage 4) and (ring 2, stage 5) of block (1,10), none of the horizontal external hop wires are connected. Similarly horizontal external hop wires are connected corresponding to "H5", "H7" etc., labels given in the hop wire connections chart 700.

"Kx" denotes an external horizontal hop wire, where symbol "K" denotes horizontal external hop wire connections starting from blocks that are "x" hop length below the leftmost column of 2D-grid 800 (i.e., column of blocks consisting of block (1, 1+x), block (2, 1+x), . . . , and block (10, 1+x)) to the same corresponding stages of the same numbered ring of another block that is directly to the right, with "x" horizontal hop length, where "x" is a positive integer. For example "K1" between the stages (ring 1, stage 4) and (ring 1, stage 5) denote that from block (1,2) of 2D-grid 800 to another block directly to the right, which is block (1,3), since "K1" denotes hop length of 1, there are external hop wire connections Hop(1,1), Hop(1,2), Hop(2,1), and Hop(2,2) from (ring 1, stage 4) and (ring 1, stage 5) of block (1,2) to (ring 1, stage 4) and (ring 1, stage 5) of block (1,3). It also means there are external hop wire connections Hop(1,1), Hop(1,2), Hop(2,1), and Hop(2,2) from (ring 1, stage 4) and (ring 1, stage 4) of block (1,4) to (ring 1, stage 4) and (ring 1, stage 5) of block (1,5). This pattern continues and finally there are external hop wire connections Hop(1,1), Hop(1,2), Hop(2,1), and Hop(2,2) from (ring 1, stage 4) and (ring 1, stage 5) of block (1,8) to (ring 1, stage 4) and (ring 1, stage 5) of block (1,9). The same pattern continues for all the rows starting from the block in the leftmost column of each row.

If there is no block that is directly to the right of a block with hop length equal to 1 then no horizontal external hop wire connections is given corresponding to those two successive stages of the blocks. For example block (1,10) does not have any block that is directly to the right and with hop length equal to 1 then none of the horizontal external hop wires are connected from (ring 1, stage 4) and (ring 1, stage 5) of block (1,10). Similarly for all the blocks in each row from the leftmost column up to the column "x", no horizontal external hop wires are connected to the corresponding (ring 1, stage 4) and (ring 1, stage 5).

Similarly "K3" between the stages (ring 2, stage 5) and (ring 2, stage 6) denote that starting from blocks that are 3 hop length to the right of the leftmost column of 2D-grid 800 (i.e., column of blocks consisting of block (1,4), block (2,4), . . . , and block (10,4)) to the same corresponding stages of the same numbered ring of another block that is directly to the right, with horizontal hop length of 3, there are external hop wire connections Hop(1,1), Hop(1,2), Hop(2,1), and Hop(2,2) connected. For example from block (1,4) of 2D-grid 800 to another block to the right and at a hop length of 3 which is block (1,7), there are external hop wire connections Hop(1,1), Hop(1,2), Hop(2,1), and Hop(2,2) from (ring 2, stage 5) and (ring 2, stage 6) of block (1,4) to (ring 2, stage 5) and (ring 2, stage 6) of block (1,7). It also means there are external hop wire connections Hop(1,1), Hop(1,2), Hop(2,1), and Hop(2,2) from (ring 2, stage 5) and (ring 2, stage 6) of block (1,5) to (ring 2, stage 5) and (ring 2, stage 6) of block (1,8). This pattern continues and finally there are external hop wire connections Hop(1,1), Hop(1,2), Hop(2,1), and Hop(2,2) from (ring 2, stage 5) and (ring 2, stage 6) of block (1,7) to (ring 2, stage 5) and (ring 2, stage 6) of block (1,10).

6) of block (1,10). The same pattern continues for all the rows starting from the block in the leftmost block of each row.

If there is no block that is directly to the right of a block with hop length equal to 3 then no horizontal external hop wire connections is given corresponding to those two successive stages of the blocks. For example block (1,8) does not have any block that is directly to the right and with hop length equal to 3 then none of the horizontal external hop wires are connected from (ring 2, stage 5) and (ring 2, stage 6) of block (1,8). Similarly from (ring 2, stage 5) and (ring 2, stage 6) of block (1,9) and from (ring 2, stage 5) and (ring 2, stage 6) of block (1,10), none of the horizontal external hop wires are connected. Similarly horizontal external hop wires are connected corresponding to "K5", "K7" etc. labels given in the hop wire connections chart 700.

In general the hop length of an external vertical hop wire can be any positive number. Similarly the hop length of an external horizontal hop wire can be any positive number. The hop wire connections between two arbitrary successive stages in two different rings of the same block or two different rings of different blocks described in diagram 700 of FIG. 7 may be any one of the embodiments of either the diagrams 300A of FIG. 3A, 300B of FIG. 3B, 400 of FIG. 4, 500 of FIG. 5, and 600 of FIG. 6.

In accordance with the current invention, either partial multi-stage hierarchical network $V_{Comb}(N_1, N_2, d, s)$ 100A of FIG. 1A or partial multi-stage hierarchical network $V_{Comb}(N_1, N_2, d, s)$ 100B of FIG. 1B, corresponding to a block of 2D-grid of blocks 800 of FIG. 8, using any one of the embodiments of 200A-200E of FIGS. 2A-2E to implement a stage of a ring of the multi-stage hierarchical network, by using the hop wire connection chart 700 of FIG. 7 and the hop wire connections between two arbitrary successive stages in two different rings of the same block or two different rings of different blocks described in diagram 700 of FIG. 7 may be any one of the embodiments of either the diagrams 300A of FIG. 3A, 300B of FIG. 3B, 400 of FIG. 4, 500 of FIG. 5, and 600 of FIG. 6 is very efficient in the reduction of the die size, power consumption, and for lower wire/path delay for higher performance for practical routing applications to particularly to set up broadcast, unicast and multicast connections. In general in accordance with the current invention, where N_1 and N_2 of the complete multi-stage hierarchical network $V_{Comb}(N_1, N_2, d, s)$ may be arbitrarily large in size and also the 2D-grid size 800 may also be arbitrarily large in size in terms of both the number of rows and number of columns.

Delay Optimizations in Multi-Stage Hierarchical Network $V_{D-Comb}(N_1, N_2, d, s)$:

The multi-stage hierarchical network $V_{Comb}(N_1, N_2, d, s)$ according to the current invention can further be optimized to reduce the delay in the routed path of the connection. The delay optimized multi-stage hierarchical network $V_{D-Comb}(N_1, N_2, d, s)$ is hereinafter denoted by $V_{D-Comb}(N_1, N_2, d, s)$. The delay optimizing embodiments of the stages of a ring are one of the diagrams namely 900A-900E of FIGS. 9A-9D, 1000A-1000F of FIGS. 10A-10F, and 1100A-1100C of FIGS. 11A-11C. The diagram 1200 of FIG. 12, 1300 of FIG. 13, 1400 of FIG. 14, and 1500 of FIG. 15 are different embodiments for the implementation of delay optimizations with all the connections between two arbitrary successive stages in two different rings of the same block or two different rings of different blocks of 2D-grid 800.

FIG. 9A illustrates a stage (ring "k", stage "m") 900A consists of 5 inputs namely $Fi(k, 2m+1)$, $Fi(k, 2m+2)$, $YFi(k, 2m+1)$, $Ui(k, 2m+1)$, and $Ui(k, 2m+2)$; and 4 outputs $Bo(k,$

$2m+1)$, $Bo(k, 2m+2)$, $Fo(k, 2m+1)$, and $Fo(k, 2m+2)$. The stage (ring "k", stage "m") also consists of seven 2:1 Muxes namely $YF(k, 2m+1)$, $F(k, 2m+1)$, $F(k, 2m+2)$, $U(k, 2m+1)$, $U(k, 2m+2)$, $B(k, 2m+1)$, and $B(k, 2m+2)$. The 2:1 Mux $YF(k, 2m+1)$ has two inputs namely $Fi(k, 2m+1)$ and $YFi(k, 2m+1)$ and has one output $YFo(k, 2m+1)$. The 2:1 Mux $F(k, 2m+1)$ has two inputs namely $YFo(k, 2m+1)$ and $Fi(k, 2m+2)$ and has one output $Fo(k, 2m+1)$. The 2:1 Mux $F(k, 2m+2)$ has two inputs namely $YFo(k, 2m+1)$ and $Fi(k, 2m+2)$ and has one output $Fo(k, 2m+2)$.

The 2:1 Mux $U(k, 2m+1)$ has two inputs namely $Ui(k, 2m+1)$ and $Fo(k, 2m+1)$ and has one output $Uo(k, 2m+1)$. The 2:1 Mux $U(k, 2m+2)$ has two inputs namely $Ui(k, 2m+2)$ and $Fo(k, 2m+2)$ and has one output $Uo(k, 2m+2)$. The 2:1 Mux $B(k, 2m+1)$ has two inputs namely $Uo(k, 2m+1)$ and $Uo(k, 2m+2)$ and has one output $Bo(k, 2m+1)$. The 2:1 Mux $B(k, 2m+2)$ has two inputs namely $Uo(k, 2m+1)$ and $Uo(k, 2m+2)$ and has one output $Bo(k, 2m+2)$.

FIG. 9B illustrates a stage (ring "k", stage "m") 900B consists of 5 inputs namely $Fi(k, 2m+1)$, $Fi(k, 2m+2)$, $YUi(k, 2m+1)$, $Ui(k, 2m+1)$, and $Ui(k, 2m+2)$; and 4 outputs $Bo(k, 2m+1)$, $Bo(k, 2m+2)$, $Fo(k, 2m+1)$, and $Fo(k, 2m+2)$. The stage (ring "k", stage "m") also consists of seven 2:1 Muxes namely $F(k, 2m+1)$, $F(k, 2m+2)$, $YF(k, 2m+1)$, $U(k, 2m+1)$, $U(k, 2m+2)$, $B(k, 2m+1)$, and $B(k, 2m+2)$. The 2:1 Mux $F(k, 2m+1)$ has two inputs namely $Fi(k, 2m+1)$ and $YFi(k, 2m+1)$ and has one output $Fo(k, 2m+1)$. The 2:1 Mux $F(k, 2m+2)$ has two inputs namely $Fi(k, 2m+1)$ and $Fi(k, 2m+2)$ and has one output $Fo(k, 2m+2)$.

The 2:1 Mux $YU(k, 2m+1)$ has two inputs namely $Ui(k, 2m+1)$ and $YUi(k, 2m+1)$ and has one output $YUo(k, 2m+1)$. The 2:1 Mux $U(k, 2m+1)$ has two inputs namely $YUo(k, 2m+1)$ and $Fo(k, 2m+1)$ and has one output $Uo(k, 2m+1)$. The 2:1 Mux $U(k, 2m+2)$ has two inputs namely $Ui(k, 2m+2)$ and $Fo(k, 2m+2)$ and has one output $Uo(k, 2m+2)$. The 2:1 Mux $B(k, 2m+1)$ has two inputs namely $Uo(k, 2m+1)$ and $Uo(k, 2m+2)$ and has one output $Bo(k, 2m+1)$. The 2:1 Mux $B(k, 2m+2)$ has two inputs namely $Uo(k, 2m+1)$ and $Uo(k, 2m+2)$ and has one output $Bo(k, 2m+2)$.

FIG. 9C illustrates a stage (ring "k", stage "m") 900C consists of 5 inputs namely $Fi(k, 2m+1)$, $Fi(k, 2m+2)$, $UYi(k, 2m+1)$, $Ui(k, 2m+1)$, and $Ui(k, 2m+2)$; and 4 outputs $Bo(k, 2m+1)$, $Bo(k, 2m+2)$, $Fo(k, 2m+1)$, and $Fo(k, 2m+2)$. The stage (ring "k", stage "m") also consists of five 2:1 Muxes namely $F(k, 2m+1)$, $F(k, 2m+2)$, $U(k, 2m+2)$, $B(k, 2m+1)$, and $B(k, 2m+2)$. The stage (ring "k", stage "m") also consists of one 3:1 Mux namely $UY(k, 2m+1)$. The 2:1 Mux $F(k, 2m+1)$ has two inputs namely $Fi(k, 2m+1)$ and $YFi(k, 2m+1)$ and has one output $Fo(k, 2m+1)$. The 2:1 Mux $F(k, 2m+2)$ has two inputs namely $Fi(k, 2m+1)$ and $Fi(k, 2m+2)$ and has one output $Fo(k, 2m+2)$.

The 3:1 Mux $UY(k, 2m+1)$ has three inputs namely $Ui(k, 2m+1)$, $UYi(k, 2m+1)$ and $Fo(k, 2m+1)$ and has one output $UYo(k, 2m+1)$. The 2:1 Mux $U(k, 2m+2)$ has two inputs namely $Ui(k, 2m+2)$ and $Fo(k, 2m+2)$ and has one output $Uo(k, 2m+2)$. The 2:1 Mux $B(k, 2m+1)$ has two inputs namely $UYo(k, 2m+1)$ and $Uo(k, 2m+2)$ and has one output $Bo(k, 2m+1)$. The 2:1 Mux $B(k, 2m+2)$ has two inputs namely $UYo(k, 2m+1)$ and $Uo(k, 2m+2)$ and has one output $Bo(k, 2m+2)$.

FIG. 9D illustrates a stage (ring "k", stage "m") 900D consists of 6 inputs namely $Fi(k, 2m+1)$, $Fi(k, 2m+2)$, $YFi(k, 2m+1)$, $Ui(k, 2m+1)$, $Ui(k, 2m+2)$, and $YUi(k, 2m+1)$; and 4 outputs $Bo(k, 2m+1)$, $Bo(k, 2m+2)$, $Fo(k, 2m+1)$, and $Fo(k, 2m+2)$. The stage (ring "k", stage "m") also consists of eight 2:1 Muxes namely $F(k, 2m+1)$, $F(k, 2m+2)$, $YF(k, 2m+1)$, $U(k, 2m+1)$, $U(k, 2m+2)$, $YU(k, 2m+1)$, $B(k, 2m+1)$, and $B(k,$

35

2m+2). The 2:1 Mux YF(k,2m+1) has two inputs namely Fi(k,2m+1) and YFi(k,2m+1) and has one output YFo(k, 2m+1). The 2:1 Mux F(k,2m+1) has two inputs namely YFo(k,2m+1) and Fi(k,2m+2) and has one output Fo(k,2m+ 1). The 2:1 Mux F(k,2m+2) has two inputs namely YFo(k, 2m+1) and Fi(k,2m+2) and has one output Fo(k,2m+2).

The 2:1 Mux YU(k,2m+1) has two inputs namely Ui(k, 2m+1) and YUi(k,2m+1) and has one output YUo(k,2m+1). The 2:1 Mux U(k,2m+1) has two inputs namely YUo(k,2m+ 1) and Fo(k,2m+1) and has one output Uo(k,2m+1). The 2:1 Mux U(k,2m+2) has two inputs namely Ui(k,2m+2) and Fo(k,2m+2) and has one output Uo(k,2m+2). The 2:1 Mux B(k,2m+1) has two inputs namely Uo(k,2m+1) and Uo(k, 2m+2) and has one output Bo(k,2m+1). The 2:1 Mux B(k,2m+2) has two inputs namely Uo(k,2m+1) and Uo(k, 2m+2) and has one output Bo(k,2m+2).

FIG. 9E illustrates a stage (ring "k", stage "m") 900E consists of 6 inputs namely Fi(k,2m+1), Fi(k,2m+2), YFi(k, 2m+1), Ui(k,2m+1), Ui(k,2m+2), and UYi(k,2m+1); and 4 outputs Bo(k,2m+1), Bo(k,2m+2), Fo(k,2m+1), and Fo(k, 2m+2). The stage (ring "k", stage "m") also consists of six 2:1 Muxes namely F(k,2m+1), F(k,2m+2), YF(k,2m+1), U(k,2m+2), B(k,2m+1), and B(k,2m+2). The stage (ring "k", stage "m") also consists of one 3:1 Mux namely UY(k,2m+1). The 2:1 Mux YF(k,2m+1) has two inputs namely Fi(k,2m+1) and YFi(k,2m+1) and has one output YFo(k,2m+1). The 2:1 Mux F(k,2m+1) has two inputs namely YFo(k,2m+1) and Fi(k,2m+2) and has one output Fo(k,2m+1). The 2:1 Mux F(k,2m+2) has two inputs namely YFo(k,2m+1) and Fi(k,2m+2) and has one output Fo(k,2m+ 2).

The 3:1 Mux UY(k,2m+1) has three inputs namely Ui(k, 2m+1), UYi(k,2m+1) and Fo(k,2m+1) and has one output UYo(k,2m+1). The 2:1 Mux U(k,2m+2) has two inputs namely Ui(k,2m+2) and Fo(k,2m+2) and has one output Uo(k,2m+2). The 2:1 Mux B(k,2m+1) has two inputs namely UYo(k,2m+1) and Uo(k,2m+2) and has one output Bo(k,2m+1). The 2:1 Mux B(k,2m+2) has two inputs namely UYo(k,2m+1) and Uo(k,2m+2) and has one output Bo(k,2m+2).

FIG. 10A illustrates a stage (ring "k", stage "m") 1000A consists of 5 inputs namely Ri(k,2m+1), Ri(k,2m+2), YRi (k,2m+1), Ui(k,2m+1), and Ui(k,2m+2); and 4 outputs Bo(k, 2m+1), Bo(k,2m+2), Fo(k,2m+1), and Fo(k,2m+2). The stage (ring "k", stage "m") also consists of nine 2:1 Muxes namely R(k,2m+1), R(k,2m+2), YR(k,2m+1), F(k,2m+1), F(k,2m+2), U(k,2m+1), U(k,2m+2), B(k,2m+1), and B(k, 2m+2). The 2:1 Mux YR(k,2m+1) has two inputs namely Ri(k,2m+1) and YRi(k,2m+1) and has one output YRo(k, 2m+1). The 2:1 Mux R(k,2m+1) has two inputs namely YRo(k,2m+1) and Bo(k,2m+1) and has one output Ro(k, 2m+1). The 2:1 Mux R(k,2m+2) has two inputs namely Ri(k,2m+2) and Bo(k,2m+2) and has one output Ro(k,2m+ 2). The 2:1 Mux F(k,2m+1) has two inputs namely Ro(k, 2m+1) and Ro(k,2m+2) and has one output Fo(k,2m+1). The 2:1 Mux F(k,2m+2) has two inputs namely Ro(k,2m+1) and Ro(k,2m+2) and has one output Fo(k,2m+2).

The 2:1 Mux U(k,2m+1) has two inputs namely Ui(k, 2m+1) and Fo(k,2m+1) and has one output Uo(k,2m+1). The 2:1 Mux U(k,2m+2) has two inputs namely Ui(k,2m+2) and Fo(k,2m+2) and has one output Uo(k,2m+2). The 2:1 Mux B(k,2m+1) has two inputs namely Uo(k,2m+1) and Uo(k,2m+2) and has one output Bo(k,2m+1). The 2:1 Mux B(k,2m+2) has two inputs namely Uo(k,2m+1) and Uo(k, 2m+2) and has one output Bo(k,2m+2).

FIG. 10B illustrates a stage (ring "k", stage "m") 1000B consists of 5 inputs namely Ri(k,2m+1), Ri(k,2m+2), RYi

36

(k,2m+1), Ui(k,2m+1), and Ui(k,2m+2); and 4 outputs Bo(k, 2m+1), Bo(k,2m+2), Fo(k,2m+1), and Fo(k,2m+2). The stage (ring "k", stage "m") also consists of seven 2:1 Muxes namely R(k,2m+2), F(k,2m+1), F(k,2m+2), U(k,2m+1), U(k,2m+2), B(k,2m+1), and B(k,2m+2). The stage (ring "k", stage "m") also consists of one 3:1 Mux namely RY(k,2m+1). The 3:1 Mux RY(k,2m+1) has three inputs namely Ri(k,2m+1), RYi(k,2m+1), and Bo(k,2m+1), and has one output RYo(k,2m+1). The 2:1 Mux R(k,2m+2) has two inputs namely Ri(k,2m+2) and Bo(k,2m+2) and has one output Ro(k,2m+2). The 2:1 Mux F(k,2m+1) has two inputs namely RYo(k,2m+1) and Ro(k,2m+2) and has one output Fo(k,2m+1). The 2:1 Mux F(k,2m+2) has two inputs namely RYo(k,2m+1) and Ro(k,2m+2) and has one output Fo(k, 2m+2).

The 2:1 Mux U(k,2m+1) has two inputs namely Ui(k, 2m+1) and Fo(k,2m+1) and has one output Uo(k,2m+1). The 2:1 Mux U(k,2m+2) has two inputs namely Ui(k,2m+2) and Fo(k,2m+2) and has one output Uo(k,2m+2). The 2:1 Mux B(k,2m+1) has two inputs namely Uo(k,2m+1) and Uo(k,2m+2) and has one output Bo(k,2m+1). The 2:1 Mux B(k,2m+2) has two inputs namely Uo(k,2m+1) and Uo(k, 2m+2) and has one output Bo(k,2m+2).

FIG. 10C illustrates a stage (ring "k", stage "m") 1000C consists of 5 inputs namely Ri(k,2m+1), Ri(k,2m+2), Ui(k, 2m+1), Ui(k,2m+2), and YUi(k,2m+1); and 4 outputs Bo(k, 2m+1), Bo(k,2m+2), Fo(k,2m+1), and Fo(k,2m+2). The stage (ring "k", stage "m") also consists of nine 2:1 Muxes namely R(k,2m+1), R(k,2m+2), F(k,2m+1), F(k,2m+2), YU(k,2m+1), U(k,2m+1), U(k,2m+2), B(k,2m+1), and B(k, 2m+2). The 2:1 Mux R(k,2m+1) has two inputs namely Ri(k,2m+1) and Bo(k,2m+1) and has one output Ro(k,2m+ 1). The 2:1 Mux R(k,2m+2) has two inputs namely Ri(k, 2m+2) and Bo(k,2m+2) and has one output Ro(k,2m+2). The 2:1 Mux F(k,2m+1) has two inputs namely Ro(k,2m+1) and Ro(k,2m+2) and has one output Fo(k,2m+1). The 2:1 Mux F(k,2m+2) has two inputs namely Ro(k,2m+1) and Ro(k,2m+2) and has one output Fo(k,2m+2).

The 2:1 Mux YU(k,2m+1) has two inputs namely Ui(k, 2m+1) and YUi(k,2m+1) and has one output YUo(k,2m+1). The 2:1 Mux U(k,2m+1) has two inputs namely YUo(k,2m+ 1) and Fo(k,2m+1) and has one output Uo(k,2m+1). The 2:1 Mux U(k,2m+2) has two inputs namely Ui(k,2m+2) and Fo(k,2m+2) and has one output Uo(k,2m+2). The 2:1 Mux B(k,2m+1) has two inputs namely Uo(k,2m+1) and Uo(k, 2m+2) and has one output Bo(k,2m+1). The 2:1 Mux B(k,2m+2) has two inputs namely Uo(k,2m+1) and Uo(k, 2m+2) and has one output Bo(k,2m+2).

FIG. 10D illustrates a stage (ring "k", stage "m") 1000D consists of 5 inputs namely Ri(k,2m+1), Ri(k,2m+2), Ui(k, 2m+1), Ui(k,2m+2), and UYi(k,2m+1); and 4 outputs Bo(k, 2m+1), Bo(k,2m+2), Fo(k,2m+1), and Fo(k,2m+2). The stage (ring "k", stage "m") also consists of seven 2:1 Muxes namely R(k,2m+1), R(k,2m+2), F(k,2m+1), F(k,2m+2), U(k,2m+2), B(k,2m+1), and B(k,2m+2). The stage (ring "k", stage "m") also consists of one 3:1 Mux namely UY(k,2m+1). The 2:1 Mux R(k,2m+1) has two inputs namely Ri(k,2m+1) and Bo(k,2m+1) and has one output Ro(k,2m+1). The 2:1 Mux R(k,2m+2) has two inputs namely Ri(k,2m+2) and Bo(k,2m+2) and has one output Ro(k,2m+2). The 2:1 Mux F(k,2m+1) has two inputs namely Ro(k,2m+1) and Ro(k,2m+2) and has one output Fo(k,2m+ 1). The 2:1 Mux F(k,2m+2) has two inputs namely Ro(k, 2m+1) and Ro(k,2m+2) and has one output Fo(k,2m+2).

The 3:1 Mux UY(k,2m+1) has three inputs namely Ui(k, 2m+1), UYi(k,2m+1), and Fo(k,2m+1), and has one output UYo(k,2m+1). The 2:1 Mux U(k,2m+2) has two inputs

BY(k,2m+2) has three inputs namely $Uo(k,2m+1)$, $Uo(k,2m+2)$, and $BYi(k,2m+2)$ and has one output $BYo(k,2m+2)$.

Referring to diagram 1200 in FIG. 12, illustrates all the connections between two arbitrary successive stages of a ring namely the stages (ring “x”, stage “p”) and (ring “x”, stage “p+1”) and two other arbitrary successive stages of any other ring namely the stages (ring “y”, stage “q”) and (ring “y”, stage “q+1”), of the complete multi-stage hierarchical network $V_{D-Comb}(N_1, N_2, d, s)$.

The stage (ring “x”, stage “p”) consists of 5 inputs namely $Ri(x,2p+1)$, $Ri(x,2p+2)$, $Ui(x,2p+1)$, $Ui(x,2p+2)$, and $UYi(x,2p+1)$; and 4 outputs $Bo(x,2p+1)$, $Bo(x,2p+2)$, $Fo(x,2p+1)$, and $Fo(x,2p+2)$. The stage (ring “x”, stage “p”) also consists of seven 2:1 Muxes namely $R(x,2p+1)$, $R(x,2p+2)$, $F(x,2p+1)$, $F(x,2p+2)$, $U(x,2p+2)$, $B(x,2p+1)$, and $B(x,2p+2)$. The stage (ring “x”, stage “p”) also consists of one 3:1 Mux namely $UY(x,2p+1)$. The 2:1 Mux $R(x,2p+1)$ has two inputs namely $Ri(x,2p+1)$ and $Bo(x,2p+1)$ and has one output $Ro(x,2p+1)$. The 2:1 Mux $R(x,2p+2)$ has two inputs namely $Ri(x,2p+2)$ and $Bo(x,2p+2)$ and has one output $Ro(x,2p+2)$. The 2:1 Mux $F(x,2p+1)$ has two inputs namely $Ro(x,2p+1)$ and $Ro(x,2p+2)$ and has one output $Fo(x,2p+1)$. The 2:1 Mux $F(x,2p+2)$ has two inputs namely $Ro(x,2p+1)$ and $Ro(x,2p+2)$ and has one output $Fo(x,2p+2)$.

The 3:1 Mux $UY(x,2p+1)$ has three inputs namely $Ui(x,2p+1)$, $UYi(x,2p+1)$, and $Fo(x,2p+1)$, and has one output $UYo(x,2p+1)$. The 2:1 Mux $U(x,2p+2)$ has two inputs namely $Ui(x,2p+2)$ and $Fo(x,2p+2)$ and has one output $Uo(x,2p+2)$. The 2:1 Mux $B(x,2p+1)$ has two inputs namely $UYo(x,2p+1)$ and $Uo(x,2p+2)$ and has one output $Bo(x,2p+1)$. The 2:1 Mux $B(x,2p+2)$ has two inputs namely $UYo(x,2p+1)$ and $Uo(x,2p+2)$ and has one output $Bo(x,2p+2)$.

The stage (ring “x”, stage “p+1”) consists of 5 inputs namely $Ri(x,2p+3)$, $Ri(x,2p+4)$, $RYi(x,2p+3)$, $Ui(x,2p+3)$, and $UYi(x,2p+3)$; and 4 outputs $Bo(x,2p+3)$, $Bo(x,2p+4)$, $Fo(x,2p+3)$, and $Fo(x,2p+4)$. The stage (ring “x”, stage “p+1”) also consists of seven 2:1 Muxes namely $R(x,2p+3)$, $R(x,2p+4)$, $F(x,2p+3)$, $F(x,2p+4)$, $U(x,2p+3)$, $U(x,2p+4)$, $B(x,2p+3)$, and $B(x,2p+4)$. The stage (ring “x”, stage “p+1”) also consists of one 3:1 Mux namely $RY(x,2p+3)$. The 3:1 Mux $RY(x,2p+3)$ has three inputs namely $Ri(x,2p+3)$, $RYi(x,2p+3)$, and $Bo(x,2p+3)$, and has one output $RYo(x,2p+3)$. The 2:1 Mux $R(x,2p+3)$ has two inputs namely $Ri(x,2p+3)$ and $Bo(x,2p+3)$ and has one output $Ro(x,2p+3)$. The 2:1 Mux $R(x,2p+4)$ has two inputs namely $Ri(x,2p+4)$ and $Bo(x,2p+4)$ and has one output $Ro(x,2p+4)$. The 2:1 Mux $F(x,2p+3)$ has two inputs namely $RYo(x,2p+3)$ and $Ro(x,2p+3)$ and has one output $Fo(x,2p+3)$. The 2:1 Mux $F(x,2p+4)$ has two inputs namely $RYo(x,2p+3)$ and $Ro(x,2p+4)$ and has one output $Fo(x,2p+4)$.

The 2:1 Mux $U(x,2p+3)$ has two inputs namely $Ui(x,2p+3)$ and $Fo(x,2p+3)$ and has one output $Uo(x,2p+3)$. The 2:1 Mux $U(x,2p+4)$ has two inputs namely $Ui(x,2p+4)$ and $Fo(x,2p+4)$ and has one output $Uo(x,2p+4)$. The 2:1 Mux $B(x,2p+3)$ has two inputs namely $Uo(x,2p+3)$ and $Uo(x,2p+4)$ and has one output $Bo(x,2p+3)$. The 2:1 Mux $B(x,2p+4)$ has two inputs namely $Uo(x,2p+3)$ and $Uo(x,2p+4)$ and has one output $Bo(x,2p+4)$.

The output $Fo(x,2p+1)$ of the stage (ring “x”, stage “p”) is connected to the input $Ri(x,2p+3)$ of the stage (ring “x”, stage “p+1”). And the output $Bo(x,2p+3)$ of the stage (ring “x”, stage “p+1”) is connected to the input $Ui(x,2p+1)$ of the stage (ring “x”, stage “p”).

The stage (ring “y”, stage “q”) consists of 5 inputs namely $Ri(y,2q+1)$, $Ri(y,2q+2)$, $Ui(y,2q+1)$, $Ui(y,2q+2)$, and $YUi(y,2q+1)$; and 4 outputs $Bo(y,2q+1)$, $Bo(y,2q+2)$, $Fo(y,2q+1)$, and $Fo(y,2q+2)$. The stage (ring “y”, stage “q”) also consists of nine 2:1 Muxes namely $R(y,2q+1)$, $R(y,2q+2)$, $F(y,2q+1)$, $F(y,2q+2)$, $YU(y,2q+1)$, $U(y,2q+1)$, $U(y,2q+2)$, $B(y,2q+1)$,

and $B(y,2q+2)$. The 2:1 Mux $R(y,2q+1)$ has two inputs namely $Ri(y,2q+1)$ and $Bo(y,2q+1)$ and has one output $Ro(y,2q+1)$. The 2:1 Mux $R(y,2q+2)$ has two inputs namely $Ri(y,2q+2)$ and $Bo(y,2q+2)$ and has one output $Ro(y,2q+2)$. The 2:1 Mux $F(y,2q+1)$ has two inputs namely $Ro(y,2q+1)$ and $Ro(y,2q+2)$ and has one output $Fo(y,2q+1)$. The 2:1 Mux $F(y,2q+2)$ has two inputs namely $Ro(y,2q+1)$ and $Ro(y,2q+2)$ and has one output $Fo(y,2q+2)$.

The 2:1 Mux $YU(y,2q+1)$ has two inputs namely $Ui(y,2q+1)$ and $YUi(y,2q+1)$ and has one output $YUo(y,2q+1)$. The 2:1 Mux $U(y,2q+1)$ has two inputs namely $YUo(y,2q+1)$ and $Fo(y,2q+1)$ and has one output $Uo(y,2q+1)$. The 2:1 Mux $U(y,2q+2)$ has two inputs namely $Ui(y,2q+2)$ and $Fo(y,2q+2)$ and has one output $Uo(y,2q+2)$. The 2:1 Mux $B(y,2q+1)$ has two inputs namely $Uo(y,2q+1)$ and $Uo(y,2q+2)$ and has one output $Bo(y,2q+1)$. The 2:1 Mux $B(y,2q+2)$ has two inputs namely $Uo(y,2q+1)$ and $Uo(y,2q+2)$ and has one output $Bo(y,2q+2)$.

The stage (ring “y”, stage “q+1”) consists of 5 inputs namely $Ri(y,2q+3)$, $Ri(y,2q+4)$, $YRi(y,2q+3)$, $Ui(y,2q+3)$, and $UYi(y,2q+3)$; and 4 outputs $Bo(y,2q+3)$, $Bo(y,2q+4)$, $Fo(y,2q+3)$, and $Fo(y,2q+4)$. The stage (ring “y”, stage “q+1”) also consists of nine 2:1 Muxes namely $R(y,2q+3)$, $R(y,2q+4)$, $YR(y,2q+3)$, $F(y,2q+3)$, $F(y,2q+4)$, $U(y,2q+3)$, $U(y,2q+4)$, $B(y,2q+3)$, and $B(y,2q+4)$. The 2:1 Mux $YR(y,2q+3)$ has two inputs namely $Ri(y,2q+3)$ and $Bo(y,2q+3)$ and has one output $YRo(y,2q+3)$. The 2:1 Mux $R(y,2q+3)$ has two inputs namely $YRo(y,2q+3)$ and $Bo(y,2q+3)$ and has one output $Ro(y,2q+3)$. The 2:1 Mux $R(y,2q+4)$ has two inputs namely $Ri(y,2q+4)$ and $Bo(y,2q+4)$ and has one output $Ro(y,2q+4)$. The 2:1 Mux $F(y,2q+3)$ has two inputs namely $Ro(y,2q+3)$ and $Ro(y,2q+4)$ and has one output $Fo(y,2q+3)$. The 2:1 Mux $F(y,2q+4)$ has two inputs namely $Ro(y,2q+3)$ and $Ro(y,2q+4)$ and has one output $Fo(y,2q+4)$.

The 2:1 Mux $U(y,2q+3)$ has two inputs namely $Ui(y,2q+3)$ and $Fo(y,2q+3)$ and has one output $Uo(y,2q+3)$. The 2:1 Mux $U(y,2q+4)$ has two inputs namely $Ui(y,2q+4)$ and $Fo(y,2q+4)$ and has one output $Uo(y,2q+4)$. The 2:1 Mux $B(y,2q+3)$ has two inputs namely $Uo(y,2q+3)$ and $Uo(y,2q+4)$ and has one output $Bo(y,2q+3)$. The 2:1 Mux $B(y,2q+4)$ has two inputs namely $Uo(y,2q+3)$ and $Uo(y,2q+4)$ and has one output $Bo(y,2q+4)$.

The output $Fo(y,2q+1)$ of the stage (ring “y”, stage “q”) is connected to the input $Ri(y,2q+3)$ of the stage (ring “y”, stage “q+1”). And the output $Bo(y,2q+3)$ of the stage (ring “y”, stage “q+1”) is connected to the input $Ui(y,2q+1)$ of the stage (ring “y”, stage “q”).

The output $Fo(x,2p+2)$ of the stage (ring “x”, stage “p”) is connected via the wire Hop(1,1) to two inputs namely input $Ri(y,2q+4)$ of the stage (ring “y”, stage “q+1”) and input $YUi(y,2q+1)$ of the stage (ring “y”, stage “q”). The output $Bo(x,2p+4)$ of the stage (ring “x”, stage “p+1”) is connected via the wire Hop(1,2) to two inputs namely input $Ui(y,2q+2)$ of the stage (ring “y”, stage “q”) and input $YRi(y,2q+3)$ of the stage (ring “y”, stage “q+1”).

The output $Fo(y,2q+2)$ of the stage (ring “y”, stage “q”) is connected via the wire Hop(2,1) to two inputs namely input $Ri(x,2p+4)$ of the stage (ring “x”, stage “p+1”) and input $UYi(x,2p+1)$ of the stage (ring “x”, stage “p”). The output $Bo(y,2q+4)$ of the stage (ring “y”, stage “q+1”) is connected via the wire Hop(2,2) to two inputs namely input $Ui(x,2p+2)$ of the stage (ring “x”, stage “p”) and input $RYi(x,2p+3)$ of the stage (ring “x”, stage “p+1”).

Referring to diagram 1300 in FIG. 13, illustrates all the connections between two arbitrary successive stages of a ring namely the stages (ring “x”, stage “p”) and (ring “x”, stage “p+1”) and two other arbitrary successive stages of any

other ring namely the stages (ring “y”, stage “q”) and (ring “y”, stage “q+1”), of the complete multi-stage hierarchical network $V_{D-Comb}(N_1, N_2, d, s)$.

The stage (ring “x”, stage “p”) consists of 6 inputs namely $Fi(x, 2p+1)$, $Fi(x, 2p+2)$, $YFi(x, 2p+1)$, $Ui(x, 2p+1)$, $Ui(x, 2p+2)$, and $YUi(x, 2p+1)$; and 4 outputs $Bo(x, 2p+1)$, $Bo(x, 2p+2)$, $Fo(x, 2p+1)$, and $Fo(x, 2p+2)$. The stage (ring “x”, stage “p”) also consists of eight 2:1 Muxes namely $F(x, 2p+1)$, $F(x, 2p+2)$, $YF(x, 2p+1)$, $U(x, 2p+1)$, $U(x, 2p+2)$, $YU(x, 2p+1)$, $B(x, 2p+1)$, and $B(x, 2p+2)$. The 2:1 Mux $YF(x, 2p+1)$ has two inputs namely $Fi(x, 2p+1)$ and $YFi(x, 2p+1)$ and has one output $YFo(x, 2p+1)$. The 2:1 Mux $F(x, 2p+1)$ has two inputs namely $YFo(x, 2p+1)$ and $Fi(x, 2p+2)$ and has one output $Fo(x, 2p+1)$. The 2:1 Mux $F(x, 2p+2)$ has two inputs namely $YFo(x, 2p+1)$ and $Fi(x, 2p+2)$ and has one output $Fo(x, 2p+2)$.

The 2:1 Mux $YU(x, 2p+1)$ has two inputs namely $Ui(x, 2p+1)$ and $YUi(x, 2p+1)$ and has one output $YUo(x, 2p+1)$. The 2:1 Mux $U(x, 2p+1)$ has two inputs namely $YUo(x, 2p+1)$ and $Fo(x, 2p+1)$ and has one output $Uo(x, 2p+1)$. The 2:1 Mux $U(x, 2p+2)$ has two inputs namely $Ui(x, 2p+2)$ and $Fo(x, 2p+2)$ and has one output $Uo(x, 2p+2)$. The 2:1 Mux $B(x, 2p+1)$ has two inputs namely $Uo(x, 2p+1)$ and $Uo(x, 2p+2)$ and has one output $Bo(x, 2p+1)$. The 2:1 Mux $B(x, 2p+2)$ has two inputs namely $Uo(x, 2p+1)$ and $Uo(x, 2p+2)$ and has one output $Bo(x, 2p+2)$.

The stage (ring “x”, stage “p+1”) consists of 6 inputs namely $Ri(x, 2p+3)$, $Ri(x, 2p+4)$, $YRi(x, 2p+3)$, $Ui(x, 2p+3)$, $Ui(x, 2p+4)$, and $YUi(x, 2p+3)$; and 4 outputs $Bo(x, 2p+3)$, $Bo(x, 2p+4)$, $Fo(x, 2p+3)$, and $Fo(x, 2p+4)$. The stage (ring “x”, stage “p+1”) also consists of ten 2:1 Muxes namely $YR(x, 2p+3)$, $R(x, 2p+3)$, $R(x, 2p+4)$, $F(x, 2p+3)$, $F(x, 2p+4)$, $YU(x, 2p+3)$, $U(x, 2p+3)$, $U(x, 2p+4)$, $B(x, 2p+3)$, and $B(x, 2p+4)$. The 2:1 Mux $YR(x, 2p+3)$ has two inputs namely $Ri(x, 2p+3)$ and $YRi(x, 2p+3)$ and has one output $YRo(x, 2p+3)$. The 2:1 Mux $R(x, 2p+3)$ has two inputs namely $YRo(x, 2p+3)$ and $Bo(x, 2p+3)$ and has one output $Ro(x, 2p+3)$. The 2:1 Mux $R(x, 2p+4)$ has two inputs namely $Ri(x, 2p+4)$ and $Bo(x, 2p+4)$ and has one output $Ro(x, 2p+4)$. The 2:1 Mux $F(x, 2p+3)$ has two inputs namely $Ro(x, 2p+3)$ and $Ro(x, 2p+4)$ and has one output $Fo(x, 2p+3)$. The 2:1 Mux $F(x, 2p+4)$ has two inputs namely $Ro(x, 2p+3)$ and $Ro(x, 2p+4)$ and has one output $Fo(x, 2p+4)$.

The 2:1 Mux $YU(x, 2p+3)$ has two inputs namely $Ui(x, 2p+3)$ and $YUi(x, 2p+3)$ and has one output $YUo(x, 2p+3)$. The 2:1 Mux $U(x, 2p+3)$ has two inputs namely $YUo(x, 2p+3)$ and $Fo(x, 2p+3)$ and has one output $Uo(x, 2p+3)$. The 2:1 Mux $U(x, 2p+4)$ has two inputs namely $Ui(x, 2p+4)$ and $Fo(x, 2p+4)$ and has one output $Uo(x, 2p+4)$. The 2:1 Mux $B(x, 2p+3)$ has two inputs namely $Uo(x, 2p+3)$ and $Uo(x, 2p+4)$ and has one output $Bo(x, 2p+3)$. The 2:1 Mux $B(x, 2p+4)$ has two inputs namely $Uo(x, 2p+3)$ and $Uo(x, 2p+4)$ and has one output $Bo(x, 2p+4)$.

The output $Fo(x, 2p+1)$ of the stage (ring “x”, stage “p”) is connected to the input $Ri(x, 2p+3)$ of the stage (ring “x”, stage “p+1”). And the output $Bo(x, 2p+3)$ of the stage (ring “x”, stage “p+1”) is connected to the input $Ui(x, 2p+1)$ of the stage (ring “x”, stage “p”).

The stage (ring “y”, stage “q”) consists of 6 inputs namely $Fi(y, 2q+1)$, $Fi(y, 2q+2)$, $YFi(y, 2q+1)$, $Ui(y, 2q+1)$, $Ui(y, 2q+2)$, and $YUi(y, 2q+1)$; and 4 outputs $Bo(y, 2q+1)$, $Bo(y, 2q+2)$, $Fo(y, 2q+1)$, and $Fo(y, 2q+2)$. The stage (ring “y”, stage “q”) also consists of six 2:1 Muxes namely $F(y, 2q+1)$, $F(y, 2q+2)$, $YF(y, 2q+1)$, $U(y, 2q+1)$, $U(y, 2q+2)$, $B(y, 2q+1)$, and $B(y, 2q+2)$. The stage (ring “y”, stage “q”) also consists of one 3:1 Mux namely $UY(y, 2q+1)$. The 2:1 Mux $YF(y, 2q+1)$ has two inputs namely $Fi(y, 2q+1)$ and $YFi(y, 2q+1)$ and has one output $YFo(y, 2q+1)$. The 2:1 Mux $F(y, 2q+1)$ has two inputs

namely $YFo(y, 2q+1)$ and $Fi(y, 2q+2)$ and has one output $Fo(y, 2q+1)$. The 2:1 Mux $F(y, 2q+2)$ has two inputs namely $YFo(y, 2q+1)$ and $Fi(y, 2q+2)$ and has one output $Fo(y, 2q+2)$.

The 3:1 Mux $UY(y, 2q+1)$ has three inputs namely $Ui(y, 2q+1)$, $YUi(y, 2q+1)$ and $Fo(y, 2q+1)$ and has one output $UYo(y, 2q+1)$. The 2:1 Mux $U(y, 2q+2)$ has two inputs namely $Ui(y, 2q+2)$ and $Fo(y, 2q+2)$ and has one output $Uo(y, 2q+2)$. The 2:1 Mux $B(y, 2q+1)$ has two inputs namely $UYo(y, 2q+1)$ and $Uo(y, 2q+2)$ and has one output $Bo(y, 2q+1)$. The 2:1 Mux $B(y, 2q+2)$ has two inputs namely $UYo(y, 2q+1)$ and $Uo(y, 2q+2)$ and has one output $Bo(y, 2q+2)$.

The stage (ring “y”, stage “q+1”) consists of 6 inputs namely $Ri(y, 2q+3)$, $Ri(y, 2q+4)$, $RYi(y, 2q+3)$, $Ui(y, 2q+3)$, $Ui(y, 2q+4)$, and $YUi(y, 2q+3)$; and 4 outputs $Bo(y, 2q+3)$, $Bo(y, 2q+4)$, $Fo(y, 2q+3)$, and $Fo(y, 2q+4)$. The stage (ring “y”, stage “q+1”) also consists of six 2:1 Muxes namely $R(y, 2q+4)$, $F(y, 2q+3)$, $F(y, 2q+4)$, $U(y, 2q+4)$, $B(y, 2q+3)$, and $B(y, 2q+4)$. The stage (ring “y”, stage “q+1”) also consists of two 3:1 Mux namely $RY(y, 2q+3)$ and $UY(y, 2q+3)$. The 3:1 Mux $RY(y, 2q+3)$ has three inputs namely $Ri(y, 2q+3)$, $RYi(y, 2q+3)$, and $Bo(y, 2q+3)$ and has one output $RYo(y, 2q+3)$. The 2:1 Mux $R(y, 2q+4)$ has two inputs namely $Ri(y, 2q+4)$ and $Bo(y, 2q+4)$ and has one output $Ro(y, 2q+4)$. The 2:1 Mux $F(y, 2q+3)$ has two inputs namely $RYo(y, 2q+3)$ and $Ro(y, 2q+4)$ and has one output $Fo(y, 2q+3)$. The 2:1 Mux $F(y, 2q+4)$ has two inputs namely $RYo(y, 2q+3)$ and $Ro(y, 2q+4)$ and has one output $Fo(y, 2q+4)$.

The 3:1 Mux $UY(y, 2q+3)$ has three inputs namely $Ui(y, 2q+3)$, $YUi(y, 2q+3)$, and $Fo(y, 2q+3)$, and has one output $UYo(y, 2q+3)$. The 2:1 Mux $U(y, 2q+4)$ has two inputs namely $Ui(y, 2q+4)$ and $Fo(y, 2q+4)$ and has one output $Uo(y, 2q+4)$. The 2:1 Mux $B(y, 2q+3)$ has two inputs namely $UYo(y, 2q+3)$ and $Uo(y, 2q+4)$ and has one output $Bo(y, 2q+3)$. The 2:1 Mux $B(y, 2q+4)$ has two inputs namely $UYo(y, 2q+3)$ and $Uo(y, 2q+4)$ and has one output $Bo(y, 2q+4)$.

The output $Fo(y, 2q+1)$ of the stage (ring “y”, stage “q”) is connected to the input $Ri(y, 2q+3)$ of the stage (ring “y”, stage “q+1”). And the output $Bo(y, 2q+3)$ of the stage (ring “y”, stage “q+1”) is connected to the input $Ui(y, 2q+1)$ of the stage (ring “y”, stage “q”).

The output $Fo(x, 2p+2)$ of the stage (ring “x”, stage “p”) is connected via the wire $Hop(1, 1)$ to two inputs namely input $Ri(y, 2q+4)$ of the stage (ring “y”, stage “q+1”) and input $YUi(y, 2q+1)$ of the stage (ring “y”, stage “q”). The output $Bo(x, 2p+4)$ of the stage (ring “x”, stage “p+1”) is connected via the wire $Hop(1, 2)$ to two inputs namely input $Ui(y, 2q+2)$ of the stage (ring “y”, stage “q”) and input $RYi(y, 2q+3)$ of the stage (ring “y”, stage “q+1”).

The output $Fo(y, 2q+2)$ of the stage (ring “y”, stage “q”) is connected via the wire $Hop(2, 1)$ to two inputs namely input $Ri(x, 2p+4)$ of the stage (ring “x”, stage “p+1”) and input $YUi(x, 2p+1)$ of the stage (ring “x”, stage “p”). The output $Bo(y, 2q+4)$ of the stage (ring “y”, stage “q+1”) is connected via the wire $Hop(2, 2)$ to two inputs namely input $Ui(x, 2p+2)$ of the stage (ring “x”, stage “p”) and input $YRi(x, 2p+3)$ of the stage (ring “x”, stage “p+1”).

Referring to diagram 1400 in FIG. 14, illustrates all the connections between two arbitrary successive stages of a ring namely the stages (ring “x”, stage “p”) and (ring “x”, stage “p+1”) and two other arbitrary successive stages of any other ring namely the stages (ring “y”, stage “q”) and (ring “y”, stage “q+1”), of the complete multi-stage hierarchical network $V_{D-Comb}(N_1, N_2, d, s)$.

The stage (ring “x”, stage “p”) consists of 5 inputs namely $Fi(x, 2p+1)$, $Fi(x, 2p+2)$, $YUi(x, 2p+1)$, $Ui(x, 2p+1)$, and $Ui(x, 2p+2)$; and 4 outputs $Bo(x, 2p+1)$, $Bo(x, 2p+2)$, $Fo(x, 2p+1)$, and $Fo(x, 2p+2)$. The stage (ring “x”, stage “p”) also consists

of seven 2:1 Muxes namely $F(x,2p+1)$, $F(x,2p+2)$, $YF(x,2p+1)$, $U(x,2p+1)$, $U(x,2p+2)$, $B(x,2p+1)$, and $B(x,2p+2)$. The 2:1 Mux $F(x,2p+1)$ has two inputs namely $Fi(x,2p+1)$ and $Fi(x,2p+2)$ and has one output $Fo(x,2p+1)$. The 2:1 Mux $F(x,2p+2)$ has two inputs namely $Fi(x,2p+1)$ and $Fi(x,2p+2)$ and has one output $Fo(x,2p+2)$.

The 2:1 Mux $YU(x,2p+1)$ has two inputs namely $Ui(x,2p+1)$ and $YUi(x,2p+1)$ and has one output $YUo(x,2p+1)$. The 2:1 Mux $U(x,2p+1)$ has two inputs namely $YUo(x,2p+1)$ and $Fo(x,2p+1)$ and has one output $Uo(x,2p+1)$. The 2:1 Mux $U(x,2p+2)$ has two inputs namely $Ui(x,2p+2)$ and $Fo(x,2p+2)$ and has one output $Uo(x,2p+2)$. The 2:1 Mux $B(x,2p+1)$ has two inputs namely $Uo(x,2p+1)$ and $Uo(x,2p+2)$ and has one output $Bo(x,2p+1)$. The 2:1 Mux $B(x,2p+2)$ has two inputs namely $Uo(x,2p+1)$ and $Uo(x,2p+2)$ and has one output $Bo(x,2p+2)$.

The stage (ring "x", stage "p+1") consists of 5 inputs namely $Fi(x,2p+3)$, $Fi(x,2p+4)$, $YFi(x,2p+3)$, $Ui(x,2p+3)$, and $Ui(x,2p+4)$; and 4 outputs $Bo(x,2p+3)$, $Bo(x,2p+4)$, $Fo(x,2p+3)$, and $Fo(x,2p+4)$. The stage (ring "x", stage "p+1") also consists of seven 2:1 Muxes namely $YF(x,2p+3)$, $F(x,2p+3)$, $F(x,2p+4)$, $U(x,2p+3)$, $U(x,2p+4)$, $B(x,2p+3)$, and $B(x,2p+4)$. The 2:1 Mux $YF(x,2p+3)$ has two inputs namely $Fi(x,2p+3)$ and $YFi(x,2p+3)$ and has one output $YFo(x,2p+3)$. The 2:1 Mux $F(x,2p+3)$ has two inputs namely $YFo(x,2p+3)$ and $Fi(x,2p+4)$ and has one output $Fo(x,2p+3)$. The 2:1 Mux $F(x,2p+4)$ has two inputs namely $YFo(x,2p+3)$ and $Fi(x,2p+4)$ and has one output $Fo(x,2p+4)$.

The 2:1 Mux $U(x,2p+3)$ has two inputs namely $Ui(x,2p+3)$ and $Fo(x,2p+3)$ and has one output $Uo(x,2p+3)$. The 2:1 Mux $U(x,2p+4)$ has two inputs namely $Ui(x,2p+4)$ and $Fo(x,2p+4)$ and has one output $Uo(x,2p+4)$. The 2:1 Mux $B(x,2p+3)$ has two inputs namely $Uo(x,2p+3)$ and $Uo(x,2p+4)$ and has one output $Bo(x,2p+3)$. The 2:1 Mux $B(x,2p+4)$ has two inputs namely $Uo(x,2p+3)$ and $Uo(x,2p+4)$ and has one output $Bo(x,2p+4)$.

The output $Fo(x,2p+1)$ of the stage (ring "x", stage "p") is connected to the input $Fi(x,2p+3)$ of the stage (ring "x", stage "p+1"). And the output $Bo(x,2p+3)$ of the stage (ring "x", stage "p+1") is connected to the input $Ui(x,2p+1)$ of the stage (ring "x", stage "p").

The stage (ring "y", stage "q") consists of 5 inputs namely $Fi(y,2q+1)$, $Fi(y,2q+2)$, $YFi(y,2q+1)$, $Ui(y,2q+1)$, and $Ui(y,2q+2)$; and 4 outputs $Bo(y,2q+1)$, $Bo(y,2q+2)$, $Fo(y,2q+1)$, and $Fo(y,2q+2)$. The stage (ring "y", stage "q") also consists of five 2:1 Muxes namely $F(y,2q+1)$, $F(y,2q+2)$, $YF(y,2q+1)$, $B(y,2q+1)$, and $B(y,2q+2)$. The stage (ring "y", stage "q") also consists of one 3:1 Mux namely $UY(y,2q+1)$. The 2:1 Mux $F(y,2q+1)$ has two inputs namely $Fi(y,2q+1)$ and $Fi(y,2q+2)$ and has one output $Fo(y,2q+1)$. The 2:1 Mux $F(y,2q+2)$ has two inputs namely $Fi(y,2q+1)$ and $Fi(y,2q+2)$ and has one output $Fo(y,2q+2)$.

The 3:1 Mux $UY(y,2q+1)$ has three inputs namely $Ui(y,2q+1)$, $YUi(y,2q+1)$ and $Fo(y,2q+1)$ and has one output $UYo(y,2q+1)$. The 2:1 Mux $U(y,2q+2)$ has two inputs namely $UYo(y,2q+1)$ and $Fo(y,2q+2)$ and has one output $Uo(y,2q+2)$. The 2:1 Mux $B(y,2q+1)$ has two inputs namely $UYo(y,2q+1)$ and $Uo(y,2q+2)$ and has one output $Bo(y,2q+1)$. The 2:1 Mux $B(y,2q+2)$ has two inputs namely $UYo(y,2q+1)$ and $Uo(y,2q+2)$ and has one output $Bo(y,2q+2)$.

The stage (ring "y", stage "q+1") consists of 5 inputs namely $Fi(y,2q+3)$, $Fi(y,2q+4)$, $YFi(y,2q+3)$, $Ui(y,2q+3)$, and $Ui(y,2q+4)$; and 4 outputs $Bo(y,2q+3)$, $Bo(y,2q+4)$, $Fo(y,2q+3)$, and $Fo(y,2q+4)$. The stage (ring "y", stage "q+1") also consists of seven 2:1 Muxes namely $YF(y,2q+3)$, $F(y,2q+3)$, $F(y,2q+4)$, $U(y,2q+3)$, $U(y,2q+4)$, $B(y,2q+3)$, and $B(y,2q+4)$. The 2:1 Mux $YF(y,2q+3)$ has two inputs

namely $Fi(y,2q+3)$ and $YFi(y,2q+3)$ and has one output $YFo(y,2q+3)$. The 2:1 Mux $F(y,2q+3)$ has two inputs namely $YFo(y,2q+3)$ and $Fi(y,2q+4)$ and has one output $Fo(y,2q+3)$. The 2:1 Mux $F(y,2q+4)$ has two inputs namely $YFo(y,2q+3)$ and $Fi(y,2q+4)$ and has one output $Fo(y,2q+4)$.

The 2:1 Mux $U(y,2q+3)$ has two inputs namely $Ui(y,2q+3)$ and $Fo(y,2q+3)$ and has one output $Uo(y,2q+3)$. The 2:1 Mux $U(y,2q+4)$ has two inputs namely $Ui(y,2q+4)$ and $Fo(y,2q+4)$ and has one output $Uo(y,2q+4)$. The 2:1 Mux $B(y,2q+3)$ has two inputs namely $Uo(y,2q+3)$ and $Uo(y,2q+4)$ and has one output $Bo(y,2q+3)$. The 2:1 Mux $B(y,2q+4)$ has two inputs namely $Uo(y,2q+3)$ and $Uo(y,2q+4)$ and has one output $Bo(y,2q+4)$.

The output $Fo(y,2q+1)$ of the stage (ring "y", stage "q") is connected to the input $Fi(y,2q+3)$ of the stage (ring "y", stage "q+1"). And the output $Bo(y,2q+3)$ of the stage (ring "y", stage "q+1") is connected to the input $Ui(y,2q+1)$ of the stage (ring "y", stage "q").

The output $Fo(x,2p+2)$ of the stage (ring "x", stage "p") is connected via the wire Hop(1,1) to two inputs namely input $Fi(y,2q+4)$ of the stage (ring "y", stage "q+1") and input $UYi(y,2q+1)$ of the stage (ring "y", stage "q"). The output $Bo(x,2p+4)$ of the stage (ring "x", stage "p+1") is connected via the wire Hop(1,2) to two inputs namely input $Ui(y,2q+2)$ of the stage (ring "y", stage "q") and input $YFi(y,2q+3)$ of the stage (ring "y", stage "q+1").

The output $Fo(y,2q+2)$ of the stage (ring "y", stage "q") is connected via the wire Hop(2,1) to two inputs namely input $Fi(x,2p+4)$ of the stage (ring "x", stage "p+1") and input $YUi(x,2p+1)$ of the stage (ring "x", stage "p"). The output $Bo(y,2q+4)$ of the stage (ring "y", stage "q+1") is connected via the wire Hop(2,2) to two inputs namely input $Ui(x,2p+2)$ of the stage (ring "x", stage "p") and input $YFi(x,2p+3)$ of the stage (ring "x", stage "p+1").

Referring to diagram 1500 in FIG. 15, illustrates all the connections between two arbitrary successive stages of a ring namely the stages (ring "x", stage "p") and (ring "x", stage "p+1") and two other arbitrary successive stages of any other ring namely the stages (ring "y", stage "q") and (ring "y", stage "q+1"), of the complete multi-stage hierarchical network $V_{D-Comb}(N_1, N_2, d, s)$.

The stage (ring "x", stage "p") consists of 5 inputs namely $Ri(x,2p+1)$, $Ri(x,2p+2)$, $Ui(x,2p+1)$, $Ui(x,2p+2)$, and $BYi(x,2p+2)$; and 4 outputs $Bo(x,2p+1)$, $Bo(x,2p+2)$, $Fo(x,2p+1)$, and $Fo(x,2p+2)$. The stage (ring "x", stage "p") also consists of seven 2:1 Muxes namely $R(x,2p+1)$, $R(x,2p+2)$, $F(x,2p+1)$, $F(x,2p+2)$, $U(x,2p+1)$, $U(x,2p+2)$, and $B(x,2p+1)$. The stage (ring "x", stage "p") also consists of one 3:1 Mux namely $BY(x,2p+2)$. The 2:1 Mux $R(x,2p+1)$ has two inputs namely $Ri(x,2p+1)$ and $Bo(x,2p+1)$ and has one output $Ro(x,2p+1)$. The 2:1 Mux $R(x,2p+2)$ has two inputs namely $Ri(x,2p+2)$ and $Bo(x,2p+2)$ and has one output $Ro(x,2p+2)$. The 2:1 Mux $F(x,2p+1)$ has two inputs namely $Ro(x,2p+1)$ and $Ro(x,2p+2)$ and has one output $Fo(x,2p+1)$. The 2:1 Mux $F(x,2p+2)$ has two inputs namely $Ro(x,2p+1)$ and $Ro(x,2p+2)$ and has one output $Fo(x,2p+2)$.

The 2:1 Mux $U(x,2p+1)$ has two inputs namely $Ui(x,2p+1)$ and $Fo(x,2p+1)$ and has one output $Uo(x,2p+1)$. The 2:1 Mux $U(x,2p+2)$ has two inputs namely $Ui(x,2p+2)$ and $Fo(x,2p+2)$ and has one output $Uo(x,2p+2)$. The 2:1 Mux $B(x,2p+1)$ has two inputs namely $Uo(x,2p+1)$ and $Uo(x,2p+2)$ and has one output $Bo(x,2p+1)$. The 3:1 Mux $BY(x,2p+2)$ has three inputs namely $Uo(x,2p+1)$, $Uo(x,2p+2)$, and $BYi(x,2p+2)$, and has one output $BYo(x,2p+2)$.

The stage (ring "x", stage "p+1") consists of 5 inputs namely $Ri(x,2p+3)$, $Ri(x,2p+4)$, $FYi(x,2p+4)$, $Ui(x,2p+3)$, and $Ui(x,2p+4)$; and 4 outputs $Bo(x,2p+3)$, $Bo(x,2p+4)$,

Fo(x,2p+3), and Fo(x,2p+4). The stage (ring “x”, stage “p+1”) also consists of seven 2:1 Muxes namely R(x,2p+3), R(x,2p+4), F(x,2p+3), U(x,2p+3), U(x,2p+4), B(x,2p+3), and B(x,2p+4). The stage (ring “x”, stage “p+1”) also consists of one 3:1 Mux namely FY(x,2p+4). The 2:1 Mux R(x,2p+3) has two inputs namely Ri(x,2p+3) and Bo(x,2p+3) and has one output Ro(x,2p+3). The 2:1 Mux R(x,2p+4) has two inputs namely Ri(x,2p+4) and Bo(x,2p+4) and has one output Ro(x,2p+4). The 2:1 Mux F(x,2p+3) has two inputs namely Ro(x,2p+3) and Ro(x,2p+4) and has one output Fo(x,2p+3). The 3:1 Mux FY(x,2p+4) has three inputs namely Ro(x,2p+3), Ro(x,2p+4), and FYi(x,2p+4), and has one output FYo(x,2p+4).

The 2:1 Mux U(x,2p+3) has two inputs namely Ui(x,2p+3) and Fo(x,2p+3) and has one output Uo(x,2p+3). The 2:1 Mux U(x,2p+4) has two inputs namely Ui(x,2p+4) and FYo(x,2p+4) and has one output Uo(x,2p+4). The 2:1 Mux B(x,2p+3) has two inputs namely Uo(x,2p+3) and Uo(x,2p+4) and has one output Bo(x,2p+3). The 2:1 Mux B(x,2p+4) has two inputs namely Uo(x,2p+3) and Uo(x,2p+4) and has one output Bo(x,2p+4).

The output Fo(x,2p+1) of the stage (ring “x”, stage “p”) is connected to the input Ri(x,2p+3) of the stage (ring “x”, stage “p+1”). And the output Bo(x,2p+3) of the stage (ring “x”, stage “p+1”) is connected to the input Ui(x,2p+1) of the stage (ring “x”, stage “p”).

The stage (ring “y”, stage “q”) consists of 6 inputs namely Ri(y,2q+1), Ri(y,2q+2), FYi(y,2q+2), Ui(y,2q+1), Ui(y,2q+2), and BYi(y,2q+2); and 4 outputs Bo(y,2q+1), Bo(y,2q+2), Fo(y,2q+1), and Fo(y,2q+2). The stage (ring “y”, stage “q”) also consists of six 2:1 Muxes namely R(y,2q+1), R(y,2q+2), F(y,2q+1), U(y,2q+1), U(y,2q+2), and B(y,2q+1). The stage (ring “y”, stage “q”) also consists of two 3:1 Muxes namely FY(y,2q+2) and BY(y,2q+2). The 2:1 Mux R(y,2q+1) has two inputs namely Ri(y,2q+1) and Bo(y,2q+1) and has one output Ro(y,2q+1). The 2:1 Mux R(y,2q+2) has two inputs namely Ri(y,2q+2) and Bo(y,2q+2) and has one output Ro(y,2q+2). The 2:1 Mux F(y,2q+1) has two inputs namely Ro(y,2q+1) and Ro(y,2q+2) and has one output Fo(y,2q+1). The 3:1 Mux FY(y,2q+2) has three inputs namely Ro(y,2q+1), Ro(y,2q+2), and FYi(y,2q+2), and has one output FYo(y,2q+2).

The 2:1 Mux U(y,2q+1) has two inputs namely Ui(y,2q+1) and Fo(y,2q+1) and has one output Uo(y,2q+1). The 2:1 Mux U(y,2q+2) has two inputs namely Ui(y,2q+2) and FYo(y,2q+2) and has one output Uo(y,2q+2). The 2:1 Mux B(y,2q+1) has two inputs namely Uo(y,2q+1) and Uo(y,2q+2) and has one output Bo(y,2q+1). The 3:1 Mux BY(y,2q+2) has three inputs namely Uo(y,2q+1), Uo(y,2q+2), and BYi(y,2q+2) and has one output BYo(y,2q+2).

The stage (ring “y”, stage “q+1”) consists of 5 inputs namely Fi(y,2q+3), Fi(y,2q+4), YFi(y,2q+3), Ui(y,2q+3), and Ui(y,2q+4); and 4 outputs Bo(y,2q+3), Bo(y,2q+4), Fo(y,2q+3), and Fo(y,2q+4). The stage (ring “y”, stage “q+1”) also consists of seven 2:1 Muxes namely YF(y,2q+3), F(y,2q+3), F(y,2q+4), U(y,2q+3), U(y,2q+4), B(y,2q+3), and B(y,2q+4). The 2:1 Mux YF(y,2q+3) has two inputs namely Fi(y,2q+3) and YFi(y,2q+3) and has one output YFo(y,2q+3). The 2:1 Mux F(y,2q+3) has two inputs namely YFo(y,2q+3) and Fi(y,2q+4) and has one output Fo(y,2q+3). The 2:1 Mux F(y,2q+4) has two inputs namely YFo(y,2q+3) and Fi(y,2q+4) and has one output Fo(y,2q+4).

The 2:1 Mux U(y,2q+3) has two inputs namely Ui(y,2q+3) and Fo(y,2q+3) and has one output Uo(y,2q+3). The 2:1 Mux U(y,2q+4) has two inputs namely Ui(y,2q+4) and Fo(y,2q+4) and has one output Uo(y,2q+4). The 2:1 Mux B(y,2q+3) has two inputs namely Uo(y,2q+3) and Uo(y,2q+

4) and has one output Bo(y,2q+3). The 2:1 Mux B(y,2q+4) has two inputs namely Uo(y,2q+3) and Uo(y,2q+4) and has one output Bo(y,2q+4).

The output Fo(y,2q+1) of the stage (ring “y”, stage “q”) is connected to the input Fi(y,2q+3) of the stage (ring “y”, stage “q+1”). And the output Bo(y,2q+3) of the stage (ring “y”, stage “q+1”) is connected to the input Ui(y,2q+1) of the stage (ring “y”, stage “q”).

The output Fo(x,2p+2) of the stage (ring “x”, stage “p”) is connected via the wire Hop(1,1) to two inputs namely input Fi(y,2q+4) of the stage (ring “y”, stage “q+1”) and input BYi(y,2q+1) of the stage (ring “y”, stage “q”). The output Bo(x,2p+4) of the stage (ring “x”, stage “p+1”) is connected via the wire Hop(1,2) to two inputs namely input Ui(y,2q+2) of the stage (ring “y”, stage “q”) and input YFi(y,2q+3) of the stage (ring “y”, stage “q+1”).

The output Fo(y,2q+2) of the stage (ring “y”, stage “q”) is connected via the wire Hop(2,1) to two inputs namely input Ri(x,2p+4) of the stage (ring “x”, stage “p+1”) and input BYi(x,2p+1) of the stage (ring “x”, stage “p”). The output Bo(y,2q+4) of the stage (ring “y”, stage “q+1”) is connected via the wire Hop(2,2) to two inputs namely input Ui(x,2p+2) of the stage (ring “x”, stage “p”) and input YFi(x,2p+4) of the stage (ring “x”, stage “p+1”).

In accordance with the current invention, either partial multi-stage hierarchical network $V_{D-Comb}(N_1, N_2, d, s)$ **100A** of FIG. 1A or partial multi-stage hierarchical network $V_{D-Comb}(N_1, N_2, d, s)$ **100B** of FIG. 1B, corresponding to a block of 2D-grid of blocks **800** of FIG. 8, using any one of the embodiments of **200A-200E** of FIGS. 2A-2E, **900A-900E** of FIGS. 9A-9E, **1000A-1000F** of FIGS. 10A-10F, **1100A-1100C** of FIGS. 11A-11C to implement a stage of a ring of the multi-stage hierarchical network, by using the hop wire connection chart **700** of FIG. 7 and the hop wire connections between two arbitrary successive stages in two different rings of the same block or two different rings of different blocks described in diagram **700** of FIG. 7 may be any one of the embodiments of either the diagrams **300A** of FIG. 3A, **300B** of FIG. 3B, **400** of FIG. 4, **500** of FIG. 5, **600** of FIG. 6, **1200** of FIG. 12, **1300** of FIG. 13, **1400** of FIG. 14, and **1500** of FIG. 15 is very efficient in the reduction of the die size, power consumption, and highly optimized for lower wire/path delay for higher performance for practical routing applications to particularly to set up broadcast, unicast and multicast connections. In general in accordance with the current invention, where N_1 and N_2 of the complete multi-stage hierarchical network $V_{D-Comb}(N_1, N_2, d, s)$ may be arbitrarily large in size and also the 2D-grid size **800** may also be arbitrarily large in size in terms of both the number of rows and number of columns.

1) Programmable Integrated Circuit Embodiments:

All the embodiments disclosed in the current invention are useful in programmable integrated circuit applications. FIG. 16A2 illustrates the detailed diagram **1600A2** for the implementation of the diagram **1600A1** in programmable integrated circuit embodiments. Each crosspoint is implemented by a transistor coupled between the corresponding inlet link and outlet link, and a programmable cell in programmable integrated circuit embodiments. Specifically crosspoint CP(1,1) is implemented by transistor C(1,1) coupled between inlet link IL1 and outlet link OL1, and programmable cell P(1,1); crosspoint CP(1,2) is implemented by transistor C(1,2) coupled between inlet link IL1 and outlet link OL2, and programmable cell P(1,2); crosspoint CP(2,1) is implemented by transistor C(2,1) coupled between inlet link IL2 and outlet link OL1, and programmable cell P(2,1); and crosspoint CP(2,2) is implemented by

transistor C(2,2) coupled between inlet link IL2 and outlet link OL2, and programmable cell P(2,2).

If the programmable cell is programmed ON, the corresponding transistor couples the corresponding inlet link and outlet link. If the programmable cell is programmed OFF, the corresponding inlet link and outlet link are not connected. For example if the programmable cell P(1,1) is programmed ON, the corresponding transistor C(1,1) couples the corresponding inlet link IL1 and outlet link OL1. If the programmable cell P(1,1) is programmed OFF, the corresponding inlet link IL1 and outlet link OL1 are not connected. In volatile programmable integrated circuit embodiments the programmable cell may be an SRAM (Static Random Address Memory) cell. In non-volatile programmable integrated circuit embodiments the programmable cell may be a Flash memory cell. Also the programmable integrated circuit embodiments may implement field programmable logic arrays (FPGA) devices, or programmable Logic devices (PLD), or Application Specific Integrated Circuits (ASIC) embedded with programmable logic circuits or 3D-FPGAs.

FIG. 16A2 also illustrates a buffer B1 on inlet link IL2. The signals driven along inlet link IL2 are amplified by buffer B1. Buffer B1 can be inverting or non-inverting buffer. Buffers such as B1 are used to amplify the signal in links which are usually long.

In other embodiments all the d*d switches described in the current invention are also implemented using muxes of different sizes controlled by SRAM cells or flash cells etc.

2) One-Time Programmable Integrated Circuit Embodiments:

All the embodiments disclosed in the current invention are useful in one-time programmable integrated circuit applications. FIG. 16A3 illustrates the detailed diagram 1600A3 for the implementation of the diagram 1600A1 in one-time programmable integrated circuit embodiments. Each crosspoint is implemented by a via coupled between the corresponding inlet link and outlet link in one-time programmable integrated circuit embodiments. Specifically crosspoint CP(1,1) is implemented by via V(1,1) coupled between inlet link IL1 and outlet link OL1; crosspoint CP(1,2) is implemented by via V(1,2) coupled between inlet link IL1 and outlet link OL2; crosspoint CP(2,1) is implemented by via V(2,1) coupled between inlet link IL2 and outlet link OL1; and crosspoint CP(2,2) is implemented by via V(2,2) coupled between inlet link IL2 and outlet link OL2.

If the via is programmed ON, the corresponding inlet link and outlet link are permanently connected which is denoted by thick circle at the intersection of inlet link and outlet link. If the via is programmed OFF, the corresponding inlet link and outlet link are not connected which is denoted by the absence of thick circle at the intersection of inlet link and outlet link. For example in the diagram 1600A3 the via V(1,1) is programmed ON, and the corresponding inlet link IL1 and outlet link OL1 are connected as denoted by thick circle at the intersection of inlet link IL1 and outlet link OL1; the via V(2,2) is programmed ON, and the corresponding inlet link IL2 and outlet link OL2 are connected as denoted by thick circle at the intersection of inlet link IL2 and outlet link OL2; the via V(1,2) is programmed OFF, and the corresponding inlet link IL1 and outlet link OL2 are not connected as denoted by the absence of thick circle at the intersection of inlet link IL1 and outlet link OL2; the via V(2,1) is programmed OFF, and the corresponding inlet link IL2 and outlet link OL1 are not connected as denoted by the absence of thick circle at the intersection of inlet link IL2

and outlet link OL1. One-time programmable integrated circuit embodiments may be anti-fuse based programmable integrated circuit devices or mask programmable structured ASIC devices.

3) Integrated Circuit Placement and Route Embodiments:

All the embodiments disclosed in the current invention are useful in Integrated Circuit Placement and Route applications, for example in ASIC backend Placement and Route tools. FIG. 16A4 illustrates the detailed diagram 1600A4 for the implementation of the diagram 1600A1 in Integrated Circuit Placement and Route embodiments. In an integrated circuit since the connections are known a-priori, the switch and crosspoints are actually virtual. However the concept of virtual switch and virtual crosspoint using the embodiments disclosed in the current invention reduces the number of required wires, wire length needed to connect the inputs and outputs of different netlists and the time required by the tool for placement and route of netlists in the integrated circuit.

Each virtual crosspoint is used to either to hardwire or provide no connectivity between the corresponding inlet link and outlet link. Specifically crosspoint CP(1,1) is implemented by direct connect point DCP(1,1) to hardwire (i.e., to permanently connect) inlet link IL1 and outlet link OL1 which is denoted by the thick circle at the intersection of inlet link IL1 and outlet link OL1; crosspoint CP(2,2) is implemented by direct connect point DCP(2,2) to hardwire inlet link IL2 and outlet link OL2 which is denoted by the thick circle at the intersection of inlet link IL2 and outlet link OL2. The diagram 1600A4 does not show direct connect point DCP(1,2) and direct connect point DCP(1,3) since they are not needed and in the hardware implementation they are eliminated. Alternatively inlet link IL1 needs to be connected to outlet link OL1 and inlet link IL1 does not need to be connected to outlet link OL2. Also inlet link IL2 needs to be connected to outlet link OL2 and inlet link IL2 does not need to be connected to outlet link OL1. Furthermore in the example of the diagram 1600A4, there is no need to drive the signal of inlet link IL1 horizontally beyond outlet link OL1 and hence the inlet link IL1 is not even extended horizontally until the outlet link OL2. Also the absence of direct connect point DCP(2,1) illustrates there is no need to connect inlet link IL2 and outlet link OL1.

In summary in integrated circuit placement and route tools, the concept of virtual switches and virtual cross points is used during the implementation of the placement & routing algorithmically in software, however during the hardware implementation cross points in the cross state are implemented as hardwired connections between the corresponding inlet link and outlet link, and in the bar state are implemented as no connection between inlet link and outlet link.

3) More Application Embodiments:

All the embodiments disclosed in the current invention are also useful in the design of SoC interconnects, Field programmable interconnect chips, parallel computer systems and in time-space-time switches.

Numerous modifications and adaptations of the embodiments, implementations, and examples described herein will be apparent to the skilled artisan in view of the disclosure.

What is claimed is:

1. A network implemented in a non-transitory medium comprising a plurality of subnetworks and a plurality of inlet links and a plurality of outlet links,
 - said plurality of subnetworks arranged in a two-dimensional grid of rows and columns; and
 - each subnetwork comprising y stages, where $y \geq 1$; and

49

each stage comprising a switch of size $d_i \times d_o$, where $d_i \geq 2$ and $d_o \geq 2$ and each switch of size $d_i \times d_o$ having d_i incoming links and d_o outgoing links; and Said inlet links are connected to one or more of said incoming links of a said switch of a said subnetwork, and said outlet links are connected to one of said outgoing links of a said switch of a said stage of a said subnetwork; and each subnetwork of the plurality of subnetworks may or may not be comprising the same number of said inlet links and may or may not be comprising the same number of said outlet links; each subnetwork of the plurality of subnetworks may or may not be comprising the same number of said stages; each stage may or may not be comprising the same number of switches; and each switch in each stage may or may not be of the same size, each multiplexer in each stage may or may not be of the same size and Said incoming links and outgoing links in each switch in each stage of each subnetwork comprising a plurality of forward connecting links connected from switches in a stage to switches in another stage in same said subnetwork or another said subnetwork, and also comprising a plurality of backward connecting links connected from switches in a stage to switches in another stage in same subnetwork or another said subnetwork; and Said forward connecting links comprising zero or more straight links connected from a switch in a stage in a subnetwork to a switch in another stage in the same subnetwork and also comprising zero or more cross links connected from a switch in a stage in a subnetwork to a switch in the same numbered stage in one or more other subnetworks, and Said backward connecting links comprising zero or more straight links connected from a switch in a stage in a subnetwork to a switch in another stage in the same subnetwork; and also comprising zero or more cross links connected from a switch in a stage in a subnetwork to a switch in the same numbered stage in one or more other subnetworks.

2. The network implemented in a non-transitory medium of claim 1 wherein said cross links between switches of stages in any two said subnetworks are connected as either vertical links only, or horizontal links only, or both vertical links and horizontal links.

3. The network implemented in a non-transitory medium of claim 2 wherein each subnetwork with its said stages is replicated in either said rows or said columns of the two-dimensional grid, or each subnetwork with said horizontal links and said vertical links connected from and said horizontal links and said vertical links connected to is replicated in either said rows or said columns of the two-dimensional grid, or each subnetwork with both its said stages, and said horizontal links and said vertical links connected from and said horizontal links and said vertical links connected to is replicated in either said rows or said columns of the two-dimensional grid.

4. The network implemented in a non-transitory medium of claim 2, wherein said horizontal links between switches in two said stages are substantially of equal length and said vertical links between switches in two said stages are substantially of equal length in the entire two-dimensional grid of rows and columns, or said horizontal links between switches in two said stages are substantially of a hop length h and said vertical

50

links between switches in two said stages are substantially of a hop length v where $h \geq 0$ and $v \geq 0$.

5. The network implemented in a non-transitory medium of claim 1, wherein said incoming cross links and said outgoing cross links are connected through only one multiplexer at each switch.

6. The network implemented in a non-transitory medium of claim 1, wherein said one or more cross links are connected between switches in two said stages that are not same numbered.

7. The network implemented in a non-transitory medium of claim 6, wherein said one or more cross links are connected between at least one same numbered stage in all said subnetworks, or said one or more cross links are connected between at least one set of two not same numbered stages in all said subnetworks.

8. The network implemented in a non-transitory medium of claim 7, wherein said one or more higher stages in a subnetwork are not connected to any other higher stages in another subnetwork when said number of rows or said number of columns are small in number, or said one or more higher stages in a subnetwork are connected to higher stages in another subnetwork by said one or more cross links when said number of rows or said number of columns are large in number.

9. The network implemented in a non-transitory medium of claim 1, wherein said cross links are implemented in two or more metal layers, or each switch is configurable by an SRAM cell or a Flash Cell or a flip-flop, or said plurality of forward connecting links use a plurality of buffers to amplify signals driven through them and said plurality of backward connecting links use a plurality of buffers to amplify signals driven through them; and said buffers are either inverting or non-inverting buffers, or some of said stages in a subnetwork comprising a switch of size $(d_i + m) \times (d_o + n)$, where $d_i \geq 2$, $d_o \geq 2$, $m \geq 0$, $n \geq 0$ and each such switch having $d_i + m$ incoming links and $d_o + n$ outgoing links, or one or more of said stages in a said subnetwork comprising six 2:1 multiplexers, or eight 2:1 multiplexers, or four 3:1 multiplexers, or four 4:1 multiplexers.

10. The network implemented in a non-transitory medium of claim 1, wherein said switches of size $d_i \times d_o$ are either fully populated or partially populated, or said plurality of subnetworks are implemented in a single dimension, or said plurality of subnetworks are either implemented in three or more dimensions or implemented in a 3D integrated circuit device.

11. A network implemented in a non-transitory medium comprising a plurality of subnetworks and a plurality of inlet links and a plurality of outlet links, said plurality of subnetworks arranged in a two-dimensional grid of rows and columns; and each subnetwork comprising y stages, where $y \geq 1$; and each stage comprising a switch of size $d_i \times d_o$, where $d_i \geq 2$ and $d_o \geq 2$ and each switch of size $d_i \times d_o$ having d_i incoming links and d_o outgoing links; and Said inlet links are connected to one or more of said incoming links of a said switch of a said stage of a said subnetwork, and said outlet links are connected to one of said outgoing links of a said switch of a said stage of a said subnetwork; and

51

each subnetwork of the plurality of subnetworks may or may not be comprising the same number of said inlet links and may or may not be comprising the same number of said outlet links; each subnetwork of the plurality of subnetworks may or may not be comprising the same number of said stages; each stage may or may not be comprising the same number of switches; and each switch in each stage may or may not be of the same size, each multiplexer in each stage may or may not be of the same size and

Said incoming links comprising zero or more straight links connected from a switch in a stage in a subnetwork to a switch in another stage in the same subnetwork, and also comprising zero or more cross links connected from a switch in a stage in a subnetwork to a switch in the same numbered stage in one or more other subnetworks, and also comprising zero or more cross links connected from a switch in a stage in a subnetwork to a switch in a different numbered stage in one or more other subnetworks, and

Said outgoing links comprising zero or more straight links connected from a switch in a stage in a subnetwork to a switch in another stage in the same subnetwork, and also comprising zero or more cross links connected from a switch in a stage in a subnetwork to a switch in the same numbered stage in one or more other subnetworks, and also comprising zero or more cross links connected from a switch in a stage in a subnetwork to a switch in a different numbered stage in one or more other subnetworks.

12. The network implemented in a non-transitory medium of claim 11 wherein said cross links between switches of stages in any two said subnetworks are connected as either vertical links only, or horizontal links only, or both vertical links and horizontal links.

13. The network implemented in a non-transitory medium of claim 12 wherein each subnetwork with its said stages is replicated in either said rows or said columns of the two-dimensional grid, or

each subnetwork with said horizontal links and said vertical links connected from and said horizontal links and said vertical links connected to is replicated in either said rows or said columns of the two-dimensional grid, or

each subnetwork with both its said stages, and said horizontal links and said vertical links connected from and said horizontal links and said vertical links connected to is replicated in either said rows or said columns of the two-dimensional grid.

14. The network implemented in a non-transitory medium of claim 12, wherein said horizontal links between switches in two said stages are substantially of equal length and said

52

vertical links between switches in two said stages are substantially of equal length in the entire two-dimensional grid of rows and columns, or

said horizontal links between switches in two said stages are substantially of a hop length h and said vertical links between switches in two said stages are substantially of a hop length v where $h \geq 0$ and $v \geq 0$.

15. The network implemented in a non-transitory medium of claim 12, wherein said one or more cross links are connected between at least one same numbered stage in all said subnetworks or

said one or more cross links are connected between at least one set of two not same numbered stages in all said subnetworks.

16. The network implemented in a non-transitory medium of claim 15, wherein said one or more higher stages in a subnetwork are not connected to any other higher stages in another subnetwork when said number of rows or said number of columns are small in number, or

said one or more higher stages in a subnetwork are connected to higher stages in another subnetwork by said one or more cross links when said number of rows or said number of columns are large in number.

17. The network implemented in a non-transitory medium of claim 11, wherein some of said stages in a subnetwork comprising a switch of size $(d_i+m) \times (d_o+n)$, where $d_i \geq 2$, $d_o \geq 2$, $m \geq 0$, $n \geq 0$ and each such switch having d_i+m incoming links and d_o+n outgoing links, or

one or more of said stages in a said subnetwork comprising six 2:1 multiplexers, or eight 2:1 multiplexers, or four 3:1 multiplexers, or four 4:1 multiplexers.

18. The network implemented in a non-transitory medium of claim 11, wherein said switches of size $d_i \times d_o$ are either fully populated or partially populated, or

said plurality of subnetworks are implemented in a single dimension, or

said plurality of subnetworks are either implemented in three or more dimensions or implemented in a 3D integrated circuit device.

19. The network implemented in a non-transitory medium of claim 11, wherein said one or more cross links are connected between at least one same numbered stage in all said subnetworks, and said same numbered stage may be any stage including the final stage.

20. The network implemented in a non-transitory medium of claim 19, wherein said one or more higher stages in a subnetwork are not connected to any other higher stages in another subnetwork when said number of rows or said number of columns are small in number, or

said one or more higher stages in a subnetwork are connected to higher stages in another subnetwork by said one or more cross links when said number of rows or said number of columns are large in number.

* * * * *