

Trials@uspto.gov  
571-272-7822

Paper 13  
Entered: September 19, 2019

UNITED STATES PATENT AND TRADEMARK OFFICE

---

BEFORE THE PATENT TRIAL AND APPEAL BOARD

---

FLEX LOGIX TECHNOLOGIES INC.,  
Petitioner,

v.

VENKAT KONDA,  
Patent Owner.

---

Case PGR2019-00040  
Patent 10,003,553 B2

---

Before PATRICK M. BOUCHER, CHARLES J. BOUDREAU, and  
NORMAN H. BEAMER, *Administrative Patent Judges*.

BOUCHER, *Administrative Patent Judge*.

DECISION  
Denying Institution of Post-Grant Review  
*35 U.S.C. § 324*

Flex Logix Technologies, Inc. (“Petitioner”) filed a Petition (Paper 1, “Pet.”) pursuant to 35 U.S.C. ¶¶ 321–329 to institute a post-grant review of claims 1–7, 9–15, and 17–19 of U.S. Patent No. 10,003,553 B2 (“the ’553

PGR2019-00040  
Patent 10,003,553

patent”). Venkat Konda (“Patent Owner”)<sup>1</sup> filed a Preliminary Response (Paper 5, “Prelim. Resp.”). For the reasons set forth below, we exercise our discretion under 35 U.S.C. § 324 and deny the Petition.

## I. BACKGROUND

### A. *The ’553 Patent*

The ’553 patent was filed on April 28, 2016, and claims the benefit of the following: (1) the March 6, 2014 filing date of U.S. Patent Appl. No. 14/199,168 (now issued as U.S. Patent No. 9,374,322 (“the ’322 patent”)); (2) the September 6, 2012 filing date of PCT/US12/53814 (“the ’814 PCT application”); and (3) the September 7, 2011 filing date of Provisional Patent Appl. No. 61/531,615 (“the ’615 provisional application”). Ex. 1001, 1:8–14; Ex. 1004, 1 (Certificate of Correction). A summary drawing provided by Petitioner is reproduced below. Pet. 4.

---

<sup>1</sup> The Petition identifies the owner of the ’553 patent as Konda Technologies, Inc. Pet. 1. This appears to have been correct at the time the Petition was filed, on March 18, 2019. But on April 8, 2019, an assignment was recorded with the Office at reel/frame 048822/0867 assigning the ’553 patent to Venkat Konda. This ownership is also reflected in Patent Owner’s mandatory notices, filed on April 9, 2019. Paper 4.

PGR2019-00040  
Patent 10,003,553

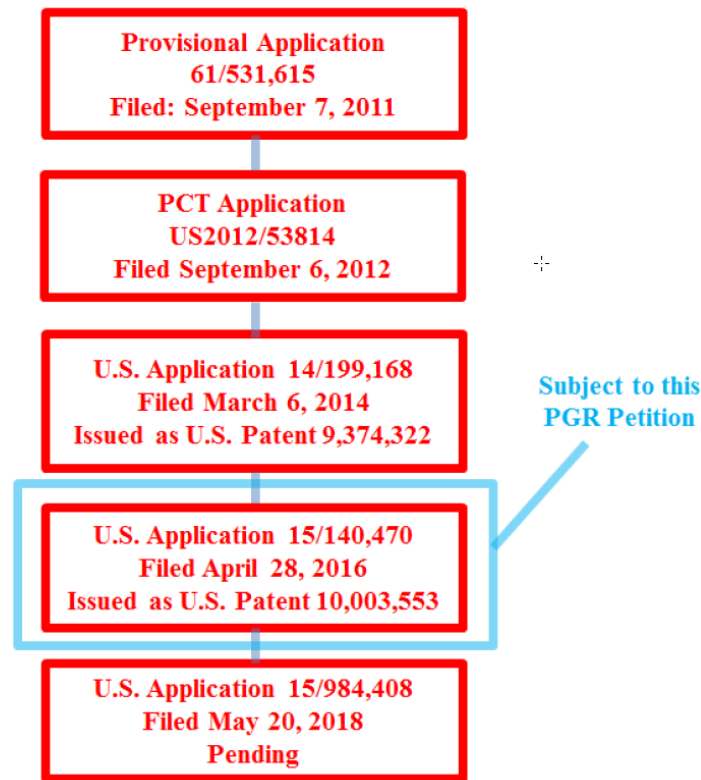

Petitioner’s drawing summarizes certain claims to earlier filing dates, and is similar to a drawing provided by Patent Owner that is in substantial agreement. *See* Prelim. Resp. 7. Although the drawing also refers to U.S. Patent Appl. No. 15/984,408, that application is not relevant to this proceeding. In addition, the ’553 patent recites that it incorporates the “entirety” of several additional patents and applications. *Id.* at 1:14–2:62.

The ’553 patent relates to multi-stage interconnection networks that find utility in multiple applications. *Id.* at 2:66–3:1. According to the ’553 patent, very large scale integration (“VLSI”) layouts for integrated circuits with such networks can be “inefficient and complicated.” *Id.* at 3:2–4. For example, prior-art networks of the type identified by the ’553 patent “require large area to implement the switches on the chip, large number of wires, longer wires, with increased power consumption, increased latency of the

PGR2019-00040  
 Patent 10,003,553

signals which [a]ffect the maximum clock speed of operation.” *Id.* at 3:43–48.

Accordingly, the ’553 patent discloses a number of configurations of multi-stage hierarchical networks. One example is illustrated in Figure 1A of the patent, reproduced below.

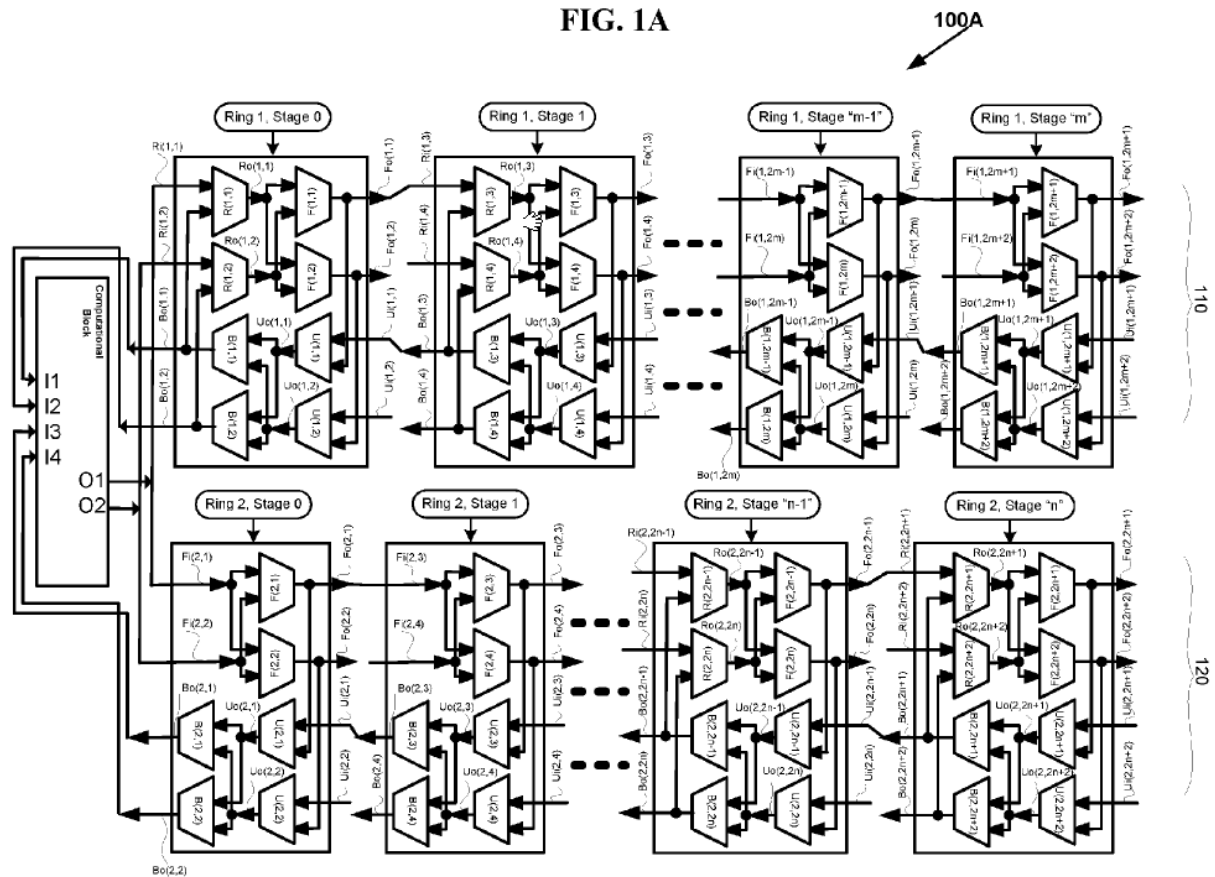

Figure 1A illustrates an exemplary partial multi-stage hierarchical network (or “block”) in which each computational block has four inlet links I1, I2, I3, I4 and two outlet links O1, O2. *Id.* at 8:57–62. For each computational block, a corresponding partial multi-stage hierarchical network has two “rings” 110, 120. *Id.* at 8:62–9:3. Ring 110 has inlet links  $Ri(1,1)$ ,  $Ri(1,2)$  and outlet links  $Bo(1,1)$ ,  $Bo(1,2)$ . *Id.* at 9:4–6. Ring 120 similarly has inlet

PGR2019-00040  
Patent 10,003,553

links  $Fi(2,1)$ ,  $Fi(2,2)$  and outlet links  $Bo(2,1)$ ,  $Bo(2,2)$ . *Id.* at 9:5–6. The partial multi-stage hierarchical network thus has four inlet links and four outlet links corresponding to the two rings 110, 120. *Id.* at 9:6–9.

Several connections characterize the specific structure illustrated. First, outlet link O1 is connected to inlet link  $Ri(1,1)$  of ring 110 and also to inlet link  $Fi(2,1)$  of ring 120. *Id.* at 9:9–11. Second, outlet link O2 is connected to inlet link  $Ri(1,2)$  of ring 110 and also to inlet link  $Fi(2,2)$  of ring 120. *Id.* at 9:11–13. Third, outlet link  $Bo(1,1)$  of ring 110 is connected to inlet link I1. *Id.* at 9:14–15. Fourth, outlet link  $Bo(1,2)$  of ring 110 is connected to inlet link I2. *Id.* at 9:15–16. Fifth, outlet link  $Bo(2,1)$  of ring 120 is connected to inlet link I3. *Id.* at 9:17–18. Sixth, outlet link  $Bo(2,2)$  of ring 120 is connected to inlet link I4. *Id.* at 9:18–20. Because outlet link O1 is connected to both inlet link  $Ri(1,1)$  of ring 110 and inlet link  $Fi(2,1)$  of ring 120, and outlet link O2 is connected to both inlet link  $Ri(1,2)$  of ring 110 and inlet link  $Fi(2,2)$  of ring 120, the partial multi-stage hierarchical network has two inlet links and four outlet links. *Id.* at 9:20–26.

The drawing also illustrates multiple “stages.” Ring 110 (i.e., ring 1) consists of  $m+1$  stages, and ring 120 (i.e., ring 2) consists of  $n+1$  stages. *Id.* at 8:65–9:1. For example, “ring 1, stage 0” has four inputs  $Ri(1,1)$ ,  $Ri(1,2)$ ,  $Ui(1,1)$ ,  $Ui(1,2)$  and four outputs  $Bo(1,1)$ ,  $Bo(1,2)$ ,  $Fo(1,1)$ ,  $Fo(1,2)$ . *Id.* at 9:62–66. That stage also has eight 2:1 multiplexers  $R(1,1)$ ,  $R(1,2)$ ,  $F(1,1)$ ,  $F(1,2)$ ,  $U(1,1)$ ,  $U(1,2)$ ,  $B(1,1)$ ,  $B(1,2)$ . *Id.* at 9:66–10:2. Multiplexer  $R(1,1)$  has two inputs  $Ri(1,1)$ ,  $Bo(1,1)$  and one output  $Ro(1,1)$ . *Id.* at 10:2–3. Multiplexer  $R(1,2)$  has two inputs  $Ri(1,2)$ ,  $Bo(1,2)$  and one output  $Ro(1,2)$ . *Id.* at 10:3–6. Multiplexer  $F(1,1)$  has two inputs  $Ro(1,1)$ ,  $Ro(1,2)$  and one

# Explore Litigation Insights

Docket Alarm provides insights to develop a more informed litigation strategy and the peace of mind of knowing you're on top of things.

## Real-Time Litigation Alerts



Keep your litigation team up-to-date with **real-time alerts** and advanced team management tools built for the enterprise, all while greatly reducing PACER spend.

Our comprehensive service means we can handle Federal, State, and Administrative courts across the country.

## Advanced Docket Research



With over 230 million records, Docket Alarm's cloud-native docket research platform finds what other services can't. Coverage includes Federal, State, plus PTAB, TTAB, ITC and NLRB decisions, all in one place.

Identify arguments that have been successful in the past with full text, pinpoint searching. Link to case law cited within any court document via Fastcase.

## Analytics At Your Fingertips



Learn what happened the last time a particular judge, opposing counsel or company faced cases similar to yours.

Advanced out-of-the-box PTAB and TTAB analytics are always at your fingertips.

## API

Docket Alarm offers a powerful API (application programming interface) to developers that want to integrate case filings into their apps.

## LAW FIRMS

Build custom dashboards for your attorneys and clients with live data direct from the court.

Automate many repetitive legal tasks like conflict checks, document management, and marketing.

## FINANCIAL INSTITUTIONS

Litigation and bankruptcy checks for companies and debtors.

## E-DISCOVERY AND LEGAL VENDORS

Sync your system to PACER to automate legal marketing.