

UNITED STATES DISTRICT COURT
DISTRICT OF MINNESOTA

Vascular Solutions, Inc.,

Civil File No. 0:13-cv-01172 (JRT-SER)

Plaintiff,

**DECLARATION OF HOWARD ROOT
IN SUPPORT OF PLAINTIFF'S
MOTION FOR PRELIMINARY
INJUNCTION**

v.

Boston Scientific Corporation,

Defendant.

I, Howard Root, hereby declare and state as follows:

1. I am the Chief Executive Officer of Plaintiff Vascular Solutions, Inc.

("VSI"). I make this Declaration in connection with VSI's motion for a preliminary injunction. I have personal knowledge of the matters set forth below and, if called as a witness, I could and would testify as follows.

Background

2. I was originally trained as a lawyer and worked in private practice from 1985-90. In 1990, I left private practice to serve as General Counsel to ATS Medical, Inc., a medical device company. I left ATS Medical and founded VSI in 1997, and I have acted as the Chief Executive Officer of VSI since its founding. Since 1997, I have been personally involved in the creation and development of VSI's products. I am a named inventor on 10 patents relating to a variety of VSI's products, including patents in the following areas: vascular access closure systems, coaxial guide extension catheters, guidewire tipped laser fibers, screw tipped penetrating catheters, and retraction belts.

VSIQXM_E00049694

3. At different times during the company's history, I have directly managed the VSI sales force, product development and marketing departments, and during all times have been personally active in VSI's sales, product development, legal and marketing efforts.

4. VSI is a medical device company focused on bringing new clinically unique solutions for vascular diseases to physicians worldwide. VSI has developed and markets over 75 different medical device products through its 91 employee U.S. sales force and international distribution network covering 49 countries. VSI had revenue of \$98 million in 2012.

Background on the Technology of this Case

5. The technology involved in this case involves cardiac (heart) catheterization, and more specifically, a medical advance that enables cardiologists to navigate medical instruments such as stents through narrow and tortuous arteries in order to treat arterial disease in coronary vessels that often could not be reached with previous technologies.

6. In coronary artery disease, a coronary artery is narrowed or occluded, often by the buildup of plaque which can reduce or entirely obstruct blood flow through the artery. A narrowing in an artery is referred to as a lesion or a stenosis. If a stenosis becomes severe, the heart muscle will not receive sufficient blood flow to continue to function appropriately, which can result in an acute myocardial infarction, commonly known as a heart attack. A coronary artery stenosis is depicted in the drawing below:

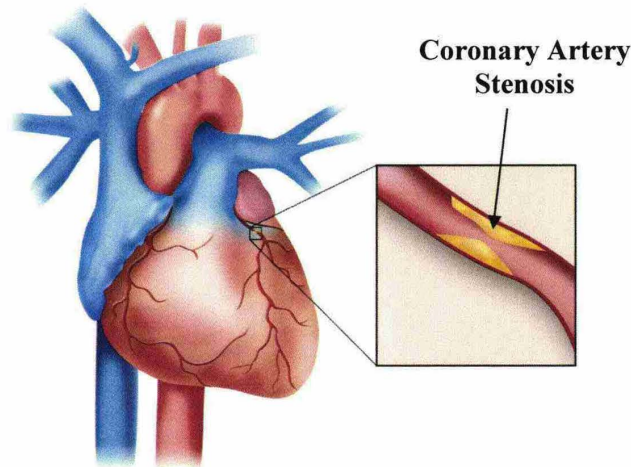

7. When a patient is suspected of having a significant stenosis in a coronary artery, the cardiologist often will perform a diagnostic coronary catheterization procedure to confirm the condition. A diagnostic catheterization consists of injecting contrast (radiopaque dye visible on an x-ray) through a diagnostic catheter (a long, thin tube) placed into the beginning of the coronary artery while viewing the artery under x-ray. The x-ray will show the presence of the radiopaque dye in the open portion of the coronary artery and the absence of dye in the area of the stenosis. A drawing of a diagnostic catheterization and an x-ray image from a diagnostic catheterization are shown below:

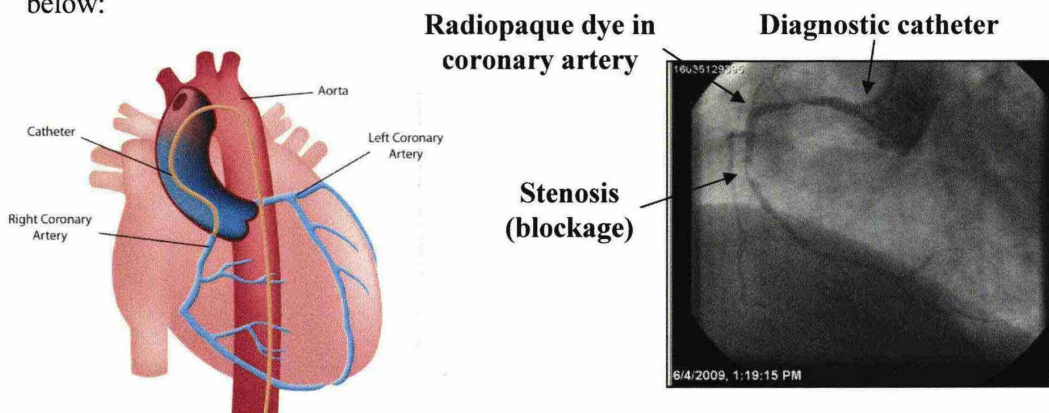

8. If the diagnostic catheterization confirms a clinically significant stenosis (such as identified in the x-ray above), the cardiologist will often perform what is called an interventional catheterization to treat (or intervene) by opening the stenosis. An interventional catheterization procedure consists of delivering medical instruments such as stents and balloons into the coronary artery and across the stenosis and then expanding the balloon and/or stent to push the stenosis to the arterial wall and re-open flow through the artery. Below is a drawing of a stent that has been opened to push a stenosis to the arterial wall and restore flow through the artery:

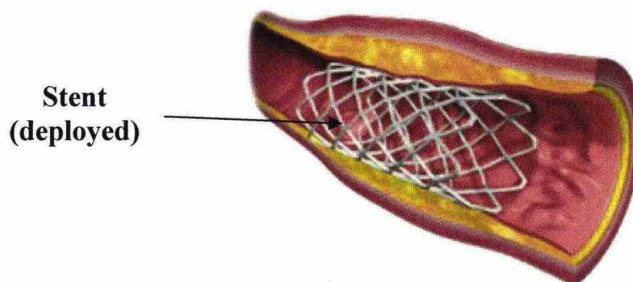

9. Cardiac catheterization procedures, whether diagnostic or interventional, are non-surgical, minimally invasive medical procedures. A cardiac catheterization starts with a needle puncture in the radial (wrist) or femoral (leg) artery of the patient in order to gain access to the arterial system. Through the hollow needle that punctured the artery a guidewire is inserted, after which the needle is removed and an introducer sheath (a short, thin tube with a valve on the end outside the body to prevent blood from leaking out) is inserted over the wire and into the artery. The introducer sheath is then used to provide continued access to the artery for the introduction of guidewires, catheters and stents during the procedure. This type of arterial access is commonly known as the

Seldinger technique, and is shown in the drawings below

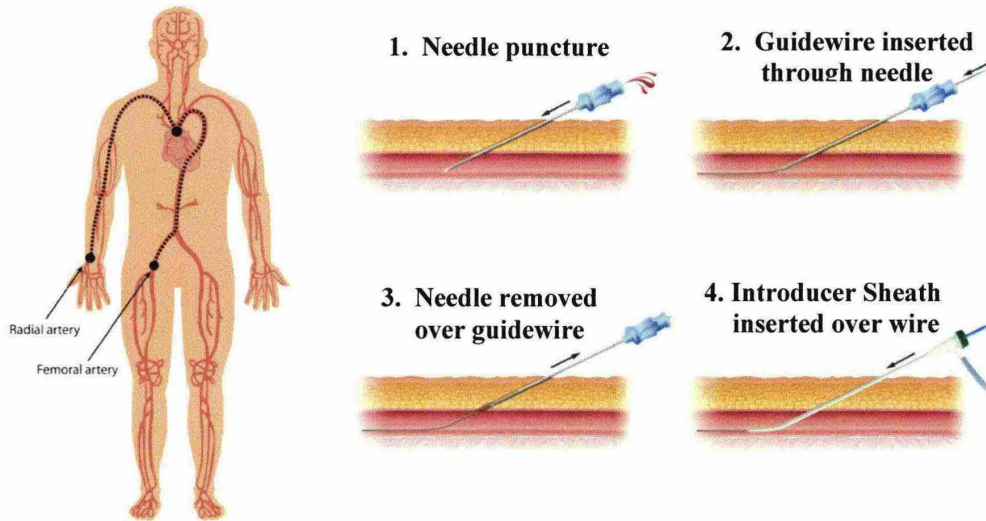

10. Using the introducer sheath as the conduit, to perform a diagnostic catheterization procedure the cardiologist will advance a diagnostic catheter into and through the aorta until it is pointing at the opening (ostium) of the coronary artery to be diagnosed (the right or left coronary artery). Once in position, dye is injected through the diagnostic catheter and into the coronary artery to allow the size and shape (and any lesions) of the artery to be observed under x-ray (see the drawing and image in paragraph 7 above). Because only dye (which is in liquid form) is injected into the coronary artery during a diagnostic catheterization procedure, a diagnostic catheter can have a small inner diameter and the tip of the diagnostic catheter does not need to precisely match the shape of the ostium of the coronary artery.

11. In an interventional catheterization procedure, instead of using a diagnostic catheter the cardiologist will use what is commonly referred to as a “guide catheter” to deliver (or guide) medical devices (such as stents) into the coronary artery to the site of

the stenosis to perform the intervention. Because the purpose of an interventional catheterization is to deliver medical instruments such as stents deep into the coronary artery and across the stenosis, a guide catheter must have a large enough inner diameter to allow passage of the commonly-used stents as well as an appropriate shape and structure to prevent dislodgement during delivery of the devices. Below is a drawing of a guide catheter seated in the coronary artery ostium (shown at 60) with an unexpanded stent in place across a stenosis (shown at 66) from Figure 7 of VSI's U.S. Patent No. 8,048,032 ('032 patent):

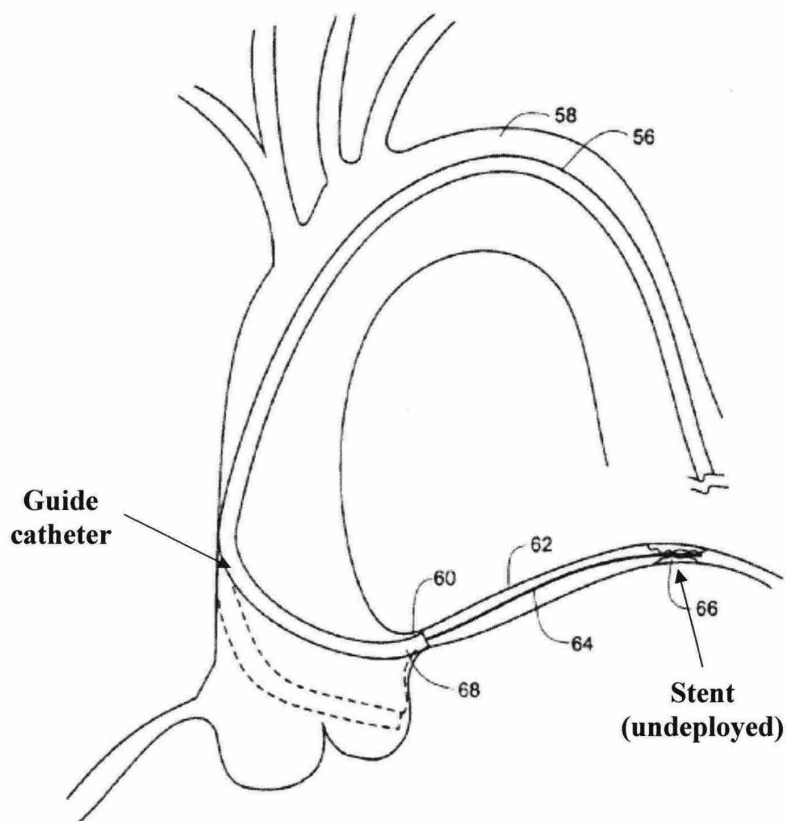

12. The guide catheter is a critical component of an interventional coronary catheterization procedure, as it is a required tool to provide the pathway for medical devices to be delivered from a distal arterial access point to a lesion for treatment. Many companies manufacture and sell guide catheters, including Boston Scientific. A standard guide catheter has a length of 100cm and has a diameter measured on the French scale (abbreviated "F"), where 1F is 1/3mm. The most common size of guide catheter is 6F (i.e., it has an outside diameter of 2mm (0.079in)), while other common sizes are 7F and 8F. Below is a drawing of a guide catheter:

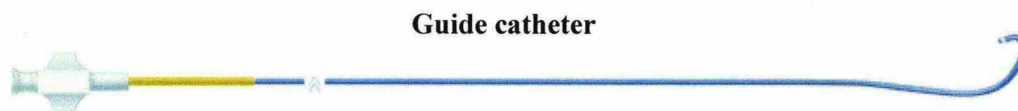

13. During use, the proximal end (i.e., the end outside the body) of a guide catheter must be sealed to prevent blood loss during the catheterization procedure. To provide this seal (while still allowing the guide catheter to be opened for delivery of medical devices), a hemostasis valve (such as the one depicted below) is attached to the proximal end of the guide catheter.

Hemostasis valve

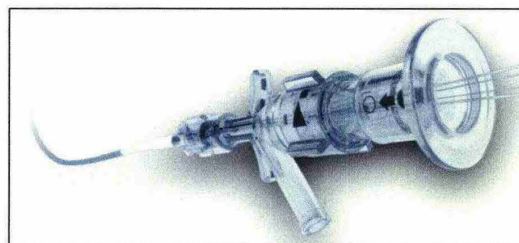

14. A guide catheter must be sufficiently rigid to allow it to maintain its distal curve (the distal end being the far end, deepest inside the body) while medical devices such as stents (which are relatively inflexible) are directed from the aorta through a 90° bend and into the ostium of the coronary artery to be treated. The guide catheter also must provide sufficient “backup” support to prevent the guide catheter from moving backwards and becoming dislodged from the ostium as the medical devices are pushed through a tight stenosis. Without this combination of guide catheter rigidity and backup support, medical devices such as stents may not be able to traverse the artery and cross the stenosis, causing the intervention to fail. Because the shape and location of coronary ostia vary widely among patients, guide catheters are manufactured with a wide variety of curve shapes to provide orientation and back-up support in these variations. Below are three common distal curve styles of guide catheters for right (JR4 and Hockey Stick) and left (EBU) coronary artery catheterizations:

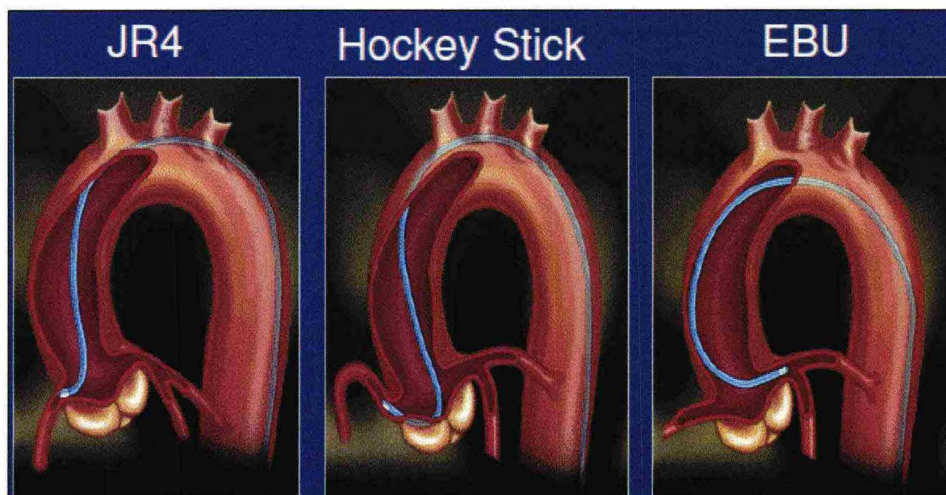

15. However, because of the curve and rigidity of a guide catheter, it generally cannot be safely “deep seated” (i.e., extended past the ostium) into the coronary artery, and instead must rest in the ostium. Therefore, while deep-seating of the guide would be helpful to significantly increase the resistance to backup and dislodgement during the stent delivery, it is generally not performed. The resulting limitation on backup support can result in dislodgement of the guide catheter and failure to deliver the treatment in challenging cases where the anatomy is tortuous and the lesion is severe, which are precisely the cases where treatment is often most needed.

16. There have been prior attempts to solve this desire to safely deep seat a guide catheter, as discussed in VSI’s ‘032 patent, at col. 1, ln. 41, to col. 2, ln. 44. One prior approach is referred to as a “mother and child” guide catheter. It involves inserting, for example, a 5F, 120cm “child” guide catheter that has a relatively flexible and straight distal tip through a standard 6F, 100cm “mother” guide catheter that is already in place at the ostium of the coronary artery. The distal end of the child catheter, being flexible and straight, can therefore safely extend through the ostium, into the bend in the artery and provide excellent backup support. Drawings of a mother and child guide catheter system and its use in a coronary artery are below:

Mother and child OTW system

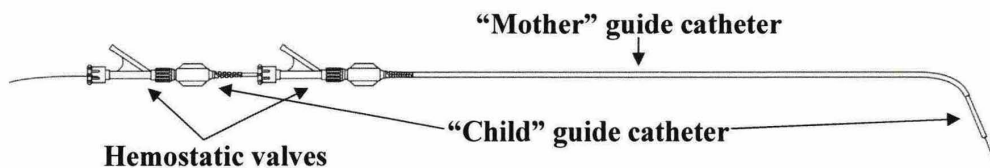

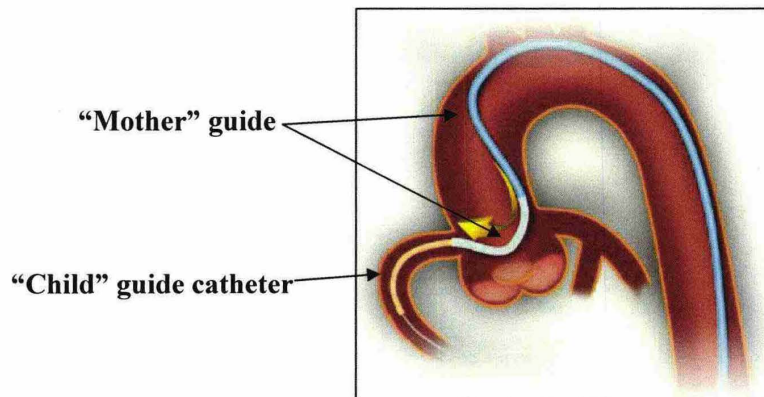

17. The Heartrail guide catheter manufactured by Terumo Corporation is an example of this "mother and child" guide catheter system, comprised of a 120cm long 5F child guide catheter extension paired with a 100cm long 6F mother guide catheter. The radiographic image below depicts the Terumo Heartrail mother and child system in use under x-ray visualization, with a stent extended through both the mother and child:

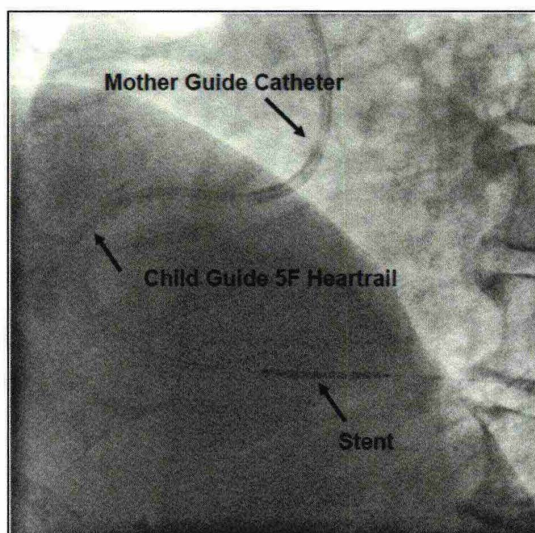

18. The mother and child system promoted by Terumo, however, has several drawbacks. One drawback is that the system requires two hemostatic valves: one to seal

the mother catheter, and a second to seal the child catheter. This tends to make the system cumbersome to use. Another drawback is the length of the system – the mother and child combination results in a 120cm long guide catheter, which limits the sites that can be treated since balloons, stents and wires are designed to be used with 100cm guide catheters. Third, to insert or remove the child catheter, all of the previously inserted medical devices, such as guidewires, must be removed. This is particularly problematic in situations where the cardiologist did not originally plan to use a child catheter, but instead the need arose in the middle of the procedure, but then requires removing all guidewires that have already been appropriately placed and starting the intervention over from the first step. As a result, before the GuideLiner, the mother and child system was rarely used.

19. The mother and child guide system utilized by Terumo is an example of an over-the-wire, or OTW, catheter. An OTW catheter has at least one uninterrupted lumen that runs the entire length of the catheter which is used for delivery of the catheter over a guidewire (i.e., the entire length of the OTW catheter is delivered “over the wire”) and into the artery. Because an OTW catheter is generally between 100cm and 150cm in length, it usually requires a long (between 260 and 300cm) guidewire for deployment, which necessitates two operators to control both ends of the catheter at the same time as it is being deployed. Shown below is a schematic drawing of a standard OTW catheter with a guidewire extending through it:

Over-the-wire (OTW) catheter



20. An alternative type of catheter used in coronary catheterization procedures is referred to as monorail, rapid exchange, single operator, or sliding rail. All of these names refer to the same type of catheter construction with a relatively short (generally 20cm – 40cm) lumen used to deliver the catheter over a guidewire, attached to a longer and stiffer push rod that is used to push and retract the catheter but runs independent of and next to the guidewire. With the monorail construction, a single operator is able to deliver the catheter and control both ends during delivery. It also allows the use of shorter guidewires (between 150cm and 190cm in length). This rail technique is explained in an article by Bonzel et al., *Z. Kardiol.* 1987; 76 Suppl. 6:119-22. A true and correct copy of the Bonzel et al. article is attached as **Exhibit 1**. Shown below is a schematic drawing showing a standard “rail” or rapid exchange catheter with a guidewire placed through it:

Rail (rapid exchange) catheter



VSI’s Development of the GuideLiner® Catheter and the Patents-in-Suit

21. Starting in 2004, I, along with other VSI employees Gregg Sutton, Jeffrey Welch, and Jason Garrity, conceived of and began to work on a new idea for a guide extension catheter that would provide “mother and child” guide extension, but without the disadvantages of the OTW construction. After years of research and testing, we developed our idea into VSI’s GuideLiner catheter, which was first sold in 2009. The GuideLiner catheter provides the advantages of “mother and child” guide extension with

the ease of monorail or rapid exchange delivery. The original GuideLiner catheter is depicted below.

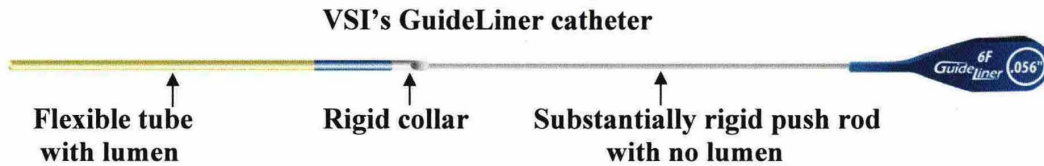

22. The distal end (yellow and blue portion) of the GuideLiner catheter is a relatively flexible tube with a lumen. This flexible portion has three zones: a very flexible yellow tip, a less flexible yellow coil reinforced portion, and a further less flexible blue portion made from a stiffer polymer as shown below:

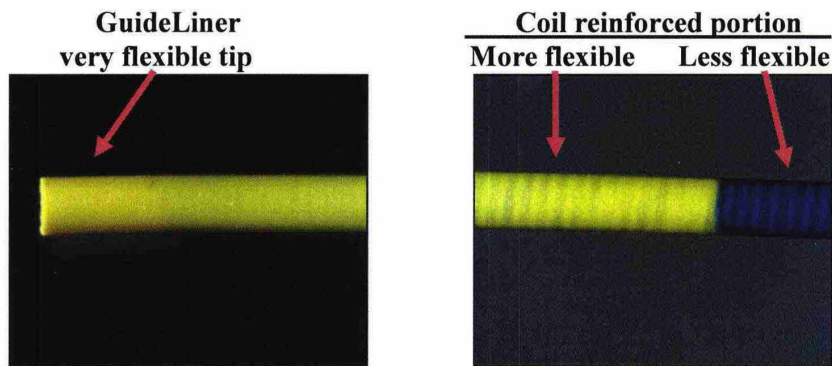

23. The flexible tube portion of the GuideLiner is joined to a relatively inflexible metal collar where the lumen ends with a sloped opening:

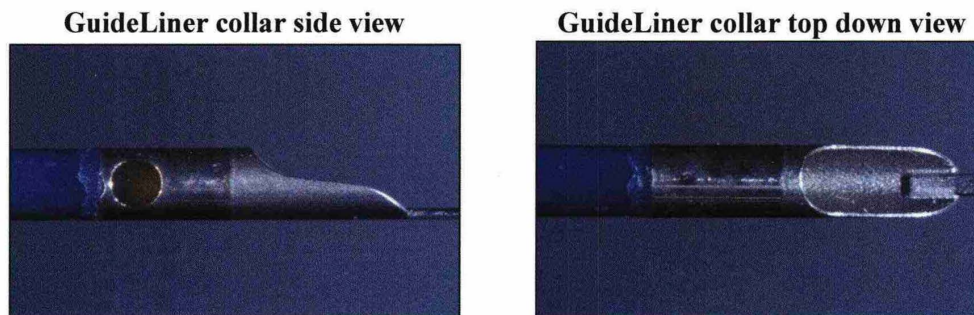

24. The collar is then connected to a substantially rigid push rod that extends for the remainder of the length of the GuideLiner catheter:

GuideLiner substantially rigid push rod

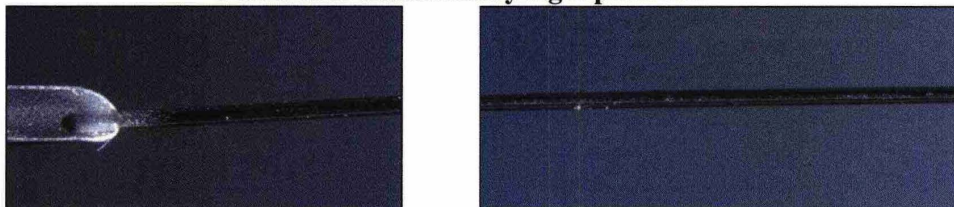

25. The proximal end of the push rod is embedded into a tab used to identify the GuideLiner catheter and prevent it from being inadvertently pushed through the hemostatic valve:

GuideLiner proximal tab

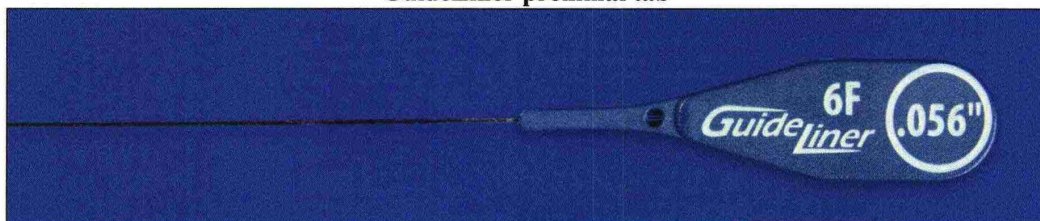

26. In use, the “child” GuideLiner catheter is inserted into the “mother” guide catheter by threading the lumen of the GuideLiner catheter’s tubular portion over the in-place guidewire. The GuideLiner catheter’s flexible tip is pushed through the guide catheter by the attached push rod and out the distal end of the “mother” guide catheter for deep seating into the coronary artery. After the GuideLiner catheter has been fully inserted into the guide catheter, when a cardiologist inserts a device such as a stent into the guide catheter, the device will travel down the guide catheter, next to the push rod, until it encounters the collar, where it will pass through the sloped opening in the collar

and into the flexible tip portion and continue until it exits the distal end of the GuideLiner catheter's flexible tip portion, into the artery to be treated.

27. By extending past the distal tip of the guide catheter and into the artery to be treated, the GuideLiner catheter provides superior back-up support through effective deep seating. And because the GuideLiner catheter's tip is flexible, the catheter can be deep seated without the risks associated with deep seating standard, much more rigid guide catheters.

28. The use of the GuideLiner catheter is illustrated in the two figures below. In the figure on the left, without the GuideLiner in place, the guide catheter has backed out of the coronary ostium, possibly from the force exerted on advancing the guidewire. In the figure on the right, the GuideLiner catheter extension has been deep seated, thus providing added support for the advancement of guidewires and stents into the artery.

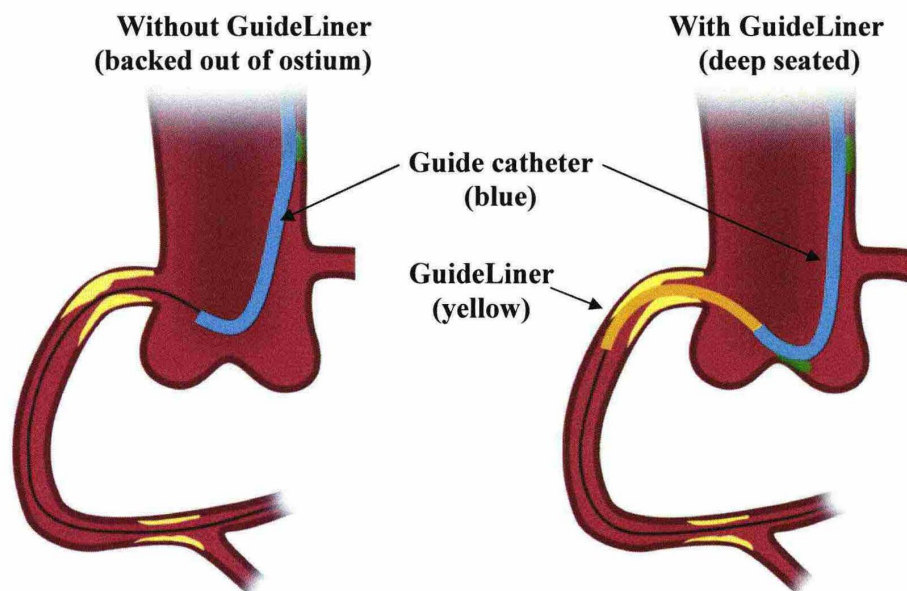

29. In another example of the use of the GuideLiner, in the illustration below on the left, without the use of a GuideLiner catheter the rigid stent cannot navigate the sharp downward turn of the vessel to reach the lesion, and therefore the procedure cannot be completed. In the figure on the right, with the use of the GuideLiner the angulated vessel's sharp angle is turned into a gentle curve, which allows the stent to make the turn and be delivered to the lesion.

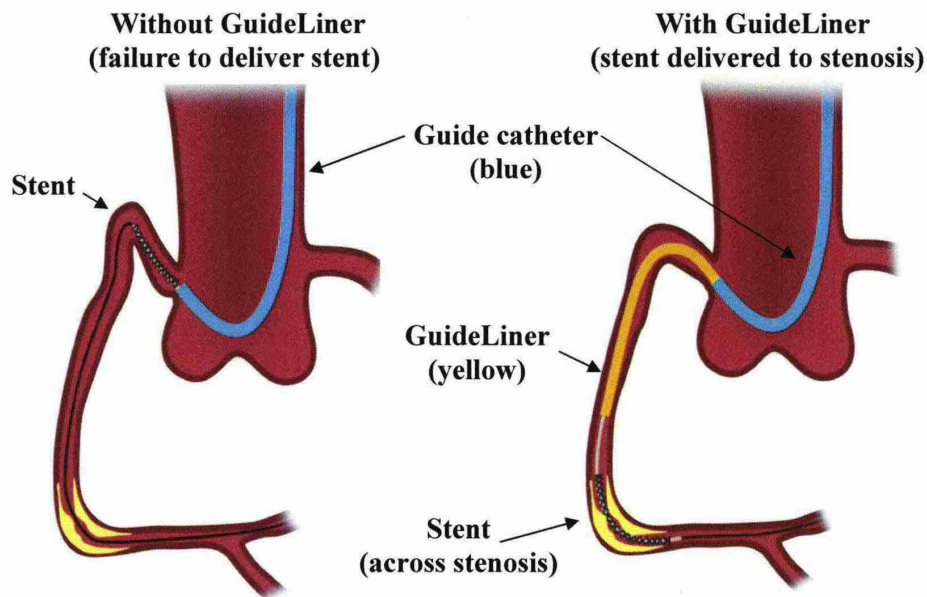

30. The monorail construction of the GuideLiner catheter provides multiple advantages to the user over the OTW construction used in prior "mother and child" systems. Because only the push rod extends through the hemostatic valve when using the GuideLiner catheter, a second hemostatic valve is not needed. In addition, since only one hemostatic valve is used, there is no need to use longer devices to reach the lesion or any limitation on the length of devices used. Furthermore, the monorail construction allows

the existing guidewires to remain in place while delivering the GuideLiner catheter into the artery, which is particularly beneficial in unplanned uses.

31. A second version of the GuideLiner catheter named the V2 was developed and sold beginning in 2012. The changes in the V2 version did not change the deployment, use or general construction of the GuideLiner catheter. The only changes made in the V2 version from the original GuideLiner (now called V1) were (a) the length of the guide extension segment was increased from 20cm to 25cm, (b) a second radiopaque marker band was added to the collar section of the catheter, and (c) the metal of the collar section was replaced with a polymer material. The first figure below is a schematic of the original (“V1”) GuideLiner catheter, and the second figure is a schematic of the second version (“V2”) of the GuideLiner catheter.

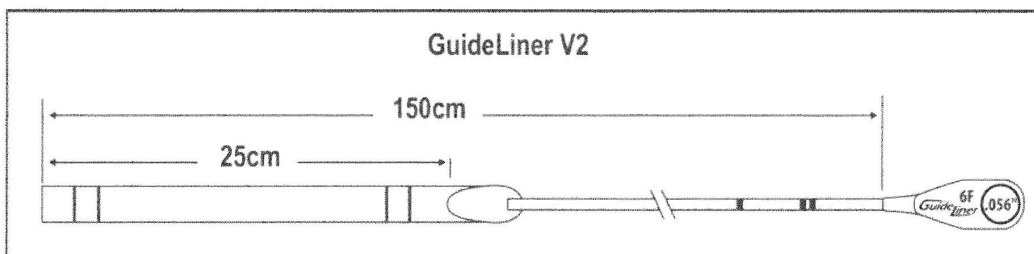
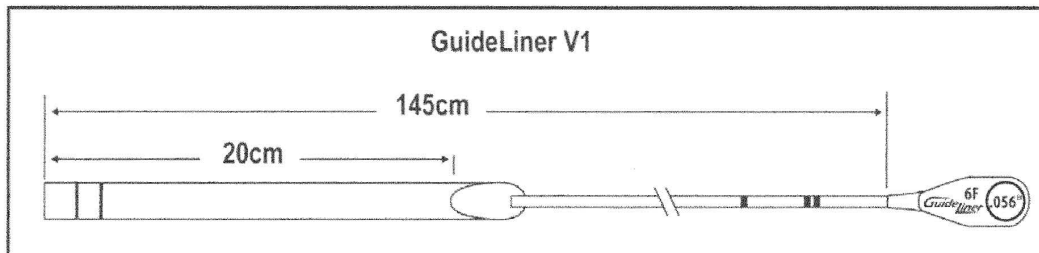

32. On May 3, 2006, my coinventors and I filed a patent application on our invention in the U.S. Patent Office. Our application led to three U.S. patents, each of which is assigned to VSI: the '032 patent, which issued November 1, 2011; U.S. Patent No. 8,142,413 ('413 patent), which issued March 27, 2012; and U.S. Patent No. 8,292,850 ('850 patent), which issued October 23, 2012. Each of these patents is entitled "Coaxial Guide Catheter for Interventional Cardiology Procedures."

33. A true and correct copy of VSI's '032 patent is attached as **Exhibit 2**.

34. A true and correct copy of VSI's '413 patent is attached as **Exhibit 3**.

35. A true and correct copy of VSI's '850 patent is attached as **Exhibit 4**.

36. Both the GuideLiner V1 and the GuideLiner V2 are embodiments of the coaxial guide catheter described and claimed in the VSI patents. In general, the '032 patent claims the device, the '413 patent claims methods of using the device, and the '850 patent claims systems combining the GuideLiner device with a guide catheter. For example, claim 1 of the '032 patent claims a device for use with a standard guide catheter to provide guide extension, with the device having a "flexible tip portion" and a "substantially rigid portion" as described above in my description of the GuideLiner products.

Success of VSI's GuideLiner catheter

37. VSI obtained CE mark clearance from its European notified body and commenced international sales of the GuideLiner catheter in September 2009.

38. VSI obtained 510(k) regulatory clearance from the U.S. Food & Drug Administration and commenced U.S. sales of the GuideLiner catheter in November 2009.

39. The GuideLiner catheter has been a very successful product for VSI.

Worldwide sales of the GuideLiner catheter since launch are provided in the table below.

Year	Worldwide Sales
2009 (4 th quarter only)	\$318,000
2010	\$4,632,000
2011	\$9,753,000
2012	\$14,742,000
2013 (1 st quarter only)	\$4,781,000
Total (through March 31, 2013)	\$34,226,000

40. From 2010 to current, the GuideLiner catheter has been VSI's fastest growing product, with sales growth of 48% in the first quarter of 2013 over the first quarter of 2012.

41. In 2012, the GuideLiner catheter was VSI's third highest-selling product in the United States, and second highest-selling product worldwide. I expect that GuideLiner catheters will be VSI's highest-selling product both in the United States and worldwide in 2013. GuideLiner catheter sales currently represent approximately 20% of VSI's total revenue.

42. Because of the completely unique nature of the GuideLiner catheter, it provides our sales force access to hospitals to sell other VSI products, and gives our sales force added credibility in that sales process. Many U.S. hospitals that have purchased the GuideLiner catheter had not purchased a VSI product in the year prior to their initial

purchase of a GuideLiner catheter. VSI would not have had access to these customers, and most of these customers subsequently purchased additional VSI products. I have prepared as **Exhibit 41** a chart setting out the total number of U.S. hospitals that have purchased a GuideLiner catheter since launch, the number of those customers who were new customers to VSI, in the sense that they had not purchased a VSI product in the year before their purchase of the GuideLiner catheter, and the average number of additional VSI products purchased by these new customers after purchasing the GuideLiner. VSI considers this level of detailed customer information to be confidential, and I respectfully ask that the Court allow us to file that exhibit under seal. I understand that counsel will be filing a separate motion seeking permission to file Exhibit 41 under seal.

43. Since 2010, twenty-two articles have been published in medical journals on the GuideLiner catheter and five medical symposia have been held on the GuideLiner catheter at medical meetings held in the United States and Europe. In addition, VSI has published twelve case reports on a range of beneficial clinical uses of the GuideLiner catheter. Attached as **Exhibit 5** is a true and correct copy of a bibliography listing GuideLiner catheter publications, symposia, and case reports. Attached as **Exhibits 6-13** are true and correct copies of articles on the GuideLiner catheter. Attached as **Exhibit 14** are clinical case reports on GuideLiner published by VSI.

44. The GuideLiner catheter has been recognized by physicians as a unique and substantial advance in cardiac catheterization. For example:

- a. From the article *Device of the Month: Catheter addresses challenging coronary interventions* (Ex. 6):

- “The GuideLiner catheter, released in November 2009 and now available for sale in the United States and Europe, is being called a ‘game-changer’ for the treatment of complex endovascular lesions.”
- “[Use of GuideLiner] greatly facilitates stent delivery, leading to a successful outcome after failure of conventional techniques. This allows complex disease to be treated more confidently, more easily and more safely.” (quoting Douglas G. Fraser, MD, BM, BChir)
- “I’ve been able to treat arteries previously deemed ‘untreatable’ and have reported on this. It is not hyperbole to refer to the GuideLiner as a game-changing device.” (quoting Kanwar P. Singh, MD, FACC)
- “According to Singh, currently in the United States, there is no competitor device to the GuideLiner.”

b. From the article *The GuideLiner™ “child” catheter* (Ex. 7):

- “In this case, stent delivery was impossible despite the use of a highly supportive guiding catheter. By using the GuideLiner™, the stent was deployed easily and successfully because of the extra-back up support and deep intubation without any displacement of the guide catheter or any vessel trauma. The GuideLiner™ provides a new alternative for performing complex interventions.”

c. From the article *Usefulness and safety of the GuideLiner catheter to enhance intubation and support of guide catheters: insights from the Twente GuideLiner registry* (Ex. 8):

- “[GuideLiner] use resulted in increased back-up and guide catheter alignment for stent delivery in unfavourable tortuous anatomies and complex, heavily calcified, and often distally located lesions, which otherwise may have been considered unsuitable for PCI [percutaneous coronary intervention]. Procedural success rate was high and there were no major complications.”
- GuideLiner “is a novel rapid exchange guide catheter extension system.”
- “During the first months, the GL was used as a bailout device in challenging cases, when the ‘old familiar tricks’ (e.g., deep-seating manoeuvres or use of buddy wires) had failed.”

d. From the article *GuideLiner Catheter Facilitated PCI – A Novel*

Device with Multiple Applications (Ex. 9):

- “The GuideLiner catheter (*Vascular Solutions, Inc.*) is a novel device that is FDA approved and CE marked for assistance with device delivery during coronary interventional procedures.”
- “The GuideLiner catheter has greatly simplified coronary intervention and broadened the lesion subsets that can be safely treated with 6 Fr guiding catheters and via the radial approach.”

e. From the article *Use of the GuideLiner Catheter for the Treatment of*

a Bifurcational Total Occlusion of the Native Left Anterior Descending Artery through a

Tortuous Composite Venous Graft (Ex. 11):

- “Our case illustrates the efficacy of the GuideLiner catheter in providing the support needed for crossing a CTO and for stent delivery in challenging cases. We used it up front due to previous failure in advancing a guidewire and a support catheter through the SVG.”
- “We report the first case of GuideLiner use in complex native coronary artery intervention through a venous graft. The atraumatic deep-seating allowed by this device provided the extra support needed to cross a CTO beyond tortuous segments and to advance devices through sharp angulations. In addition, its monorail design allowed its easy advancement through the hemostatic valve and easy handling of balloons and stents.”

f. From the article *The GuideLiner “Child” Catheter for Percutaneous*

Coronary Intervention – Early Clinical Experience (Ex. 12):

- “All cases involved intervention of the RCA, for which extra backup support is often required. In some cases, stent delivery was impossible despite the use of a highly supportive guiding catheter, buddy wires and a buddy balloon. The GuideLiner catheter provided the additional backup support required for stent delivery. Deep target-vessel intubation was possible without displacement of the guiding catheter/wire or vessel trauma.”

g. From the article *Distal Stent Delivery With Guideliner Catheter*:

First in Man Experience (Ex. 13):

- “The GuideLiner catheter was used for stent delivery following prior failure using conventional techniques or upfront use due to anticipated failure Balloon and stent delivery was successfully achieved in all cases and the device was simple both to deploy and remove and was not associated with a procedural complication in any case.”
- “Advantages of the Guideliner include not needing to remove and reconnect the Y connector, less risk of air embolism, easier control of the mother catheter, easier advancement and removal, and ability to advance a stent further distal beyond the catheter tip.”
- “The Guideliner is an easy to use guide catheter extension that greatly facilitates backup support and stent delivery, significantly extending the scope of coronary intervention possible within a 6F mother guide catheter.”

45. Cardiologists have provided comments about the use of the GuideLiner

catheter that VSI has included in GuideLiner marketing materials, among them these:

- Douglas Fraser, M.D., of Manchester Heart Centre in Manchester, United Kingdom, stated: “The GuideLiner is as easy to insert as a standard rapid exchange balloon catheter and has quickly become a routine part of my angioplasty practice.”
- Matthew Price, M.D., FACC, FSCAI, of Scripps Clinic in La Jolla, California, stated: “The GuideLiner has become an indispensable part of my tool kit for complex PCI. Simply put, it’s a game changer.”
- Mehdi Shishehbor, DO, MPH, of Cleveland Clinic in Cleveland, Ohio, stated: “All interventional cardiologists should be familiar with the GuideLiner – it can really save you one day!”
- Ashish Pershad, M.D., FACC, FSCAI, of Heart and Vascular Center of Arizona, in Phoenix, Arizona, stated: “The GuideLiner allows me to successfully complete previously unimaginable interventions.”

Attached as **Exhibit 15** are true and correct copies of the forms verifying the physicians’ consent to use their statements.

Boston Scientific and its Infringing Guidezilla Catheter

46. Boston Scientific is a large medical device company, which based on public filings had reported worldwide revenue of \$7.2 billion in 2012. Attached as **Exhibit 16** is a true and correct copy of an excerpt from Boston Scientific's website, printed on May 27, 2013. Attached as **Exhibit 17** is a true and correct excerpt from Boston Scientific's 2012 Annual Report.

47. According to its website and Annual Report, Boston Scientific develops and markets medical devices through seven divisions: cardiac rhythm management, electrophysiology, endoscopy, interventional cardiology, neuromodulation, peripheral interventions, and urology and women's health. *See* Ex. 16 at 1-7; Ex. 17 at 3. The interventional cardiology business accounted for 30% of Boston Scientific's sales in 2012. *See* Ex. 17 at 2.

48. Boston Scientific is the largest medical device company in the U.S. market for interventional cardiology devices, with a 40% share of the market according to 2010 market research estimates. Attached as **Exhibit 18** is a true and correct copy of a market research report. Through its interventional cardiology division, Boston Scientific sells a variety of medical devices in eleven product sub-categories into this market, including drug-eluting stents, balloon catheters, guide wires, and guide catheters. In its Annual Report, Boston Scientific attributes the success of its interventional cardiology business largely to its coronary stent product offerings. *See* Ex. 17 at 7. Boston Scientific promotes more than forty separate interventional cardiology products on its website. *See*

Ex. 16 at 8-18. Even within the specific category of “guide catheters,” Boston Scientific promotes four different products. *See* Ex. 16 at 13.

49. Since VSI launched its GuideLiner catheter in 2009, interventional cardiologists have used VSI’s GuideLiner catheter to deliver Boston Scientific’s drug-eluting stents into coronary arteries. I expect, based on my experience in this industry, that Boston Scientific’s sales and marketing employees are aware of the use of GuideLiner in delivering Boston Scientific’s stents.

50. According to public records, on February 14, 2012 Boston Scientific filed a trademark application on “Guidezilla” for use as a medical guide catheter with the U.S. Patent & Trademark Office. Attached as **Exhibit 19** is a true and correct copy of Boston Scientific’s trademark application, printed from the records of the U.S. Patent & Trademark Office.

51. On October 2, 2012, I met the president of Boston Scientific’s Interventional Cardiology Division, Kevin Ballinger, at an event sponsored by the trade organization LifeScience Alley, in St. Louis Park, Minnesota. I had previously heard rumors that Boston Scientific may be developing a new guide extension catheter, so at the event I asked Mr. Ballinger if Boston Scientific was developing a new guide catheter called Godzilla or Guidezilla. In response, Mr. Ballinger stated that Boston Scientific had not developed a new guide catheter in over a decade.

52. On October 16, 2012, I sent a letter to Mr. Ballinger informing him of the patents-in-suit. Attached as **Exhibit 20** is a true and correct copy of the letter (without copies of the patents, which were enclosed). Mr. Ballinger did not respond.

53. I regularly track the Food & Drug Administration (“FDA”) filings for new medical devices. During March 2013, I discovered that Boston Scientific had prepared a 510(k) application with the FDA for the Guidezilla catheter on December 6, 2012 and filed it on February 19, 2013. Attached as **Exhibit 21** is a true and correct copy of the application and clearance letter from the FDA website.

54. Boston Scientific’s 510(k) filing identifies the GuideLiner catheter as the only predicate device for the Guidezilla catheter. The Guidezilla catheter’s “Intended Use / Indications for Use” included in the 510(k) application is the same as the current Intended Use that VSI created and provides with its GuideLiner catheter.

55. As part of its filing with the FDA, Boston Scientific stated the following: “The GUIDEZILLA™ Guide Extension Catheter incorporates substantially equivalent device materials and design, packaging materials and design, fundamental technology, manufacturing processes, sterilization process and intended use as the GuideLiner V2 (K112082).” Ex. 21 at 1.

56. Boston Scientific received 510(k) clearance from the FDA for the Guidezilla catheter on March 19, 2013. *See* Ex. 21.

57. Sam Rasmussen was employed as a Senior Product Manager at VSI from June 2006 through November 2006, a time period during which VSI was actively developing its GuideLiner catheter and during which time Rasmussen’s office was close to members of the GuideLiner product development team. Rasmussen voluntarily left VSI’s employ in November 2006 and is currently employed as a Senior Product Manager at Boston Scientific. Based on information received through VSI’s sales force, I believe

that Rasmussen is responsible for providing marketing leadership for the launch of the Guidezilla catheter at Boston Scientific.

58. On March 21, 2013, Rasmussen contacted VSI's sales representative for the Minnesota territory, Matt Nigon, wanting to discuss the GuideLiner catheter. Rasmussen asked Nigon about the market size and pricing for the GuideLiner catheter.

59. On April 12, 2013, I learned from Susan Griffith, a VSI account manager, that Boston Scientific had provided a Guidezilla catheter for clinical use at Barnes Jewish Hospital in St. Louis, Missouri, where it was used on a patient. At that time, I still had not seen an actual Guidezilla catheter. I subsequently learned through various account managers and physicians that additional Guidezilla catheters have been provided by Boston Scientific since April 12, 2013, for clinical use in California, Illinois, New York, and numerous other states across the United States.

60. On April 25, 2013, I sent another letter to Mr. Ballinger, asking to see any analysis performed by Boston Scientific with respect to the patents-in-suit, to purchase a sample of the Guidezilla for evaluation, and to discuss the issue. Attached as **Exhibit 22** is a true and correct copy of the letter. On May 3, 2013, I received a written reply stating only that Mr. Ballinger had forwarded my letter to his legal department for review. Attached as **Exhibit 23** is a true and correct copy of the reply. No further response was received from Ballinger or Boston Scientific until after VSI served its Complaint.

61. On May 6, 2013, I obtained my first sample of the Guidezilla catheter from an outside source. I obtained a second sample on May 8, 2013, along with the Guidezilla Directions for Use and packaging. I personally examined Boston Scientific's Guidezilla

catheter. Photographs of the catheter were taken at my direction.

62. Attached as **Exhibit 24** is a true and correct photograph of the front and back of the box in which Boston Scientific sells its Guidezilla catheter, as well as a photograph of the inner pouch containing the catheter. Boston Scientific's packaging indicates that its Guidezilla catheter is "Made in U.S.A."

63. Boston Scientific includes with the Guidezilla catheter shipped to a customer in the United States its Directions for Use. Attached as **Exhibit 25** is a true and correct copy of the Directions for Use for the Guidezilla catheter that I received.

64. Boston Scientific describes its Guidezilla catheter in its Directions for Use as "a single lumen rapid exchange catheter" with "a stainless steel proximal shaft with a 25 cm single lumen distal guide segment . . ." Ex. 25 at 2. This description is the same as VSI's description of its GuideLiner catheter in its Instructions for Use ("IFU") as "a single lumen rapid exchange catheter" with "a stainless steel shaft with a 25cm single lumen . . ." A true and correct copy of the GuideLiner V2 IFU is attached as **Exhibit 26**.

65. VSI obtained copyright registrations for both its GuideLiner V1 and GuideLiner V2 IFUs. Attached as **Exhibit 27** are true and correct copies of U.S. Copyright Registration Nos. TX-7-679-165 and TX-7-679-167.

66. Boston Scientific's Directions for Use for its Guidezilla catheter is a copy of the VSI IFU for its GuideLiner catheter, including the "Deployment Procedure" / "Delivery Procedure" section as shown below (language copied from GuideLiner catheter Instructions into Guidezilla Directions is shown in bold):

GuideLiner	Guidezilla
<p>Deploy the GuideLiner catheter according to the following steps:</p> <ol style="list-style-type: none"> 1. Secure the previously inserted guidewire and backload the distal tip of the GuideLiner catheter onto the guidewire and advance until the catheter is just proximal to the hemostasis valve. 2. Open the hemostasis valve and advance the GuideLiner catheter through the hemostasis valve and into the guide catheter. 3. Under fluoroscopy, advance the GuideLiner catheter up to a maximum of 15cm beyond the distal tip of the guide catheter and into the desired location within the vessel. <p>Warning: Never advance the GuideLiner catheter into a vessel with an effective diameter less than 2.5mm. Vessel injury, ischemia, and/or occlusion may result. If pressure in a vessel dampens after inserting the GuideLiner catheter, withdraw the GuideLiner catheter until the pressure returns to normal.</p> <p>Warning: Due to the size and non-tapered tip of the GuideLiner, extreme care must be taken to avoid vessel occlusion and damage to the wall of the vessels through which this catheter passes.</p> <ol style="list-style-type: none"> 4. Using fluoroscopy, confirm the desired position of the GuideLiner catheter in the vessel. 5. If performing an interventional procedure, backload the interventional device over the in place guidewire and advance the device through the guide catheter and GuideLiner catheter into the 	<p>Deliver the Guidezilla device according to the following steps:</p> <ol style="list-style-type: none"> 1. Secure the previously inserted guidewire and backload the distal tip of the Guidezilla device onto the guidewire and advance until the device is just proximal to the hemostasis valve. 2. Open the hemostasis valve and advance the Guidezilla device through the hemostasis valve and into the guide catheter. 3. Under fluoroscopy, advance the Guidezilla device up to a maximum of 15 cm beyond the distal tip of the guide catheter and into the desired location within the vessel. <p>Warning: Never advance the Guidezilla device into a vessel with an effective diameter less than 2.5 mm. Vessel injury, ischemia, and/or occlusion may result. If pressure in a vessel dampens after inserting the Guidezilla catheter, withdraw the Guidezilla catheter until the pressure returns to normal.</p> <p>Warning: Due to the size and non-tapered tip of the Guidezilla device, extreme care must be taken to avoid vessel occlusion and damage to the wall of the vessels through which this catheter passes.*</p> <ol style="list-style-type: none"> 4. Using fluoroscopy, confirm the desired position of the Guidezilla device in the vessel. 5. If performing an interventional procedure, backload the interventional device over the guidewire and advance the device through the guide catheter and Guidezilla device into the

<p>desired vascular space.</p> <p>6. Tighten the Y-adaptor hemostasis valve securely on the proximal shaft of the GuideLiner catheter to prevent back-bleeding.</p> <p>7. Perform the catheterization procedure. After completing the procedure, remove the GuideLiner catheter prior to removing the guide catheter from the vessel.</p>	<p>desired vascular space.</p> <p>Note: Use caution when advancing the interventional device into the distal guide segment.</p> <p>6. Tighten the Y-adaptor hemostasis valve securely on the proximal shaft of the Guidezilla device to prevent back-bleeding.</p> <p>7. Perform the catheterization procedure. After completing the procedure, remove the Guidezilla device prior to removing the guide catheter from the vessel.</p>
--	---

* The order of the two warnings is reversed in the Guidezilla document. *Compare* Ex. 25 at 3 (Guidezilla), *with* Ex. 26 at 2 (GuideLiner).

67. In connection with its clinical evaluation process, which Boston Scientific refers to as its “Guidezilla Limited Market Evaluation,” I understand that Boston Scientific provides physicians with a “New Product Evaluation Form.” Attached as **Exhibit 28** is a true and correct copy of a New Product Evaluation Form that was completed after the use of a Guidezilla device at Memorial Medical Center in Springfield, Illinois which I received on April 23, 2013 from Tony Palma, a VSI associate account manager. The form asks physicians to disclose, among other information, the type of GuideLiner catheter they use in their practices, the percentages of cases in which they use the GuideLiner catheter, and the current cost of a GuideLiner catheter for their facility. The form also asks physicians to complete a “GUIDEZILLA Catheter vs. GuideLiner Catheter Evaluation.”

68. The drawing and section photographs below are true and correct representations and photographs of Boston Scientific's Guidezilla catheter, prepared and taken at my direction.

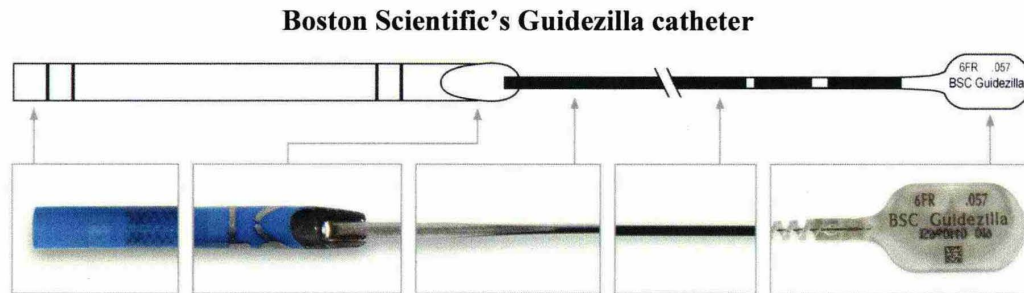

69. Boston Scientific's Guidezilla catheter is a copy of VSI's GuideLiner catheter. Guidezilla's design and dimensions are materially the same as those of the GuideLiner catheter and those described and claimed in the patents-in-suit. Attached as **Exhibit 29** is a true and correct copy of drawings comparing the dimensions of the Guidezilla catheter, the GuideLiner V1 catheter, and the Guideliner V2 catheter, and comparing aspects of the Guidezilla catheter to figures in the '032 patent. Attached as **Exhibit 30** is a true and correct series of photographs comparing aspects of the Guidezilla catheter to the GuideLiner V1 and V2 catheters.

70. The drawings below show a comparison of the Guidezilla catheter to the GuideLiner V2 catheter and to an excerpt of Figure 1 of the patents-in-suit (the orientation of the patent drawing has been flipped for comparison purposes):

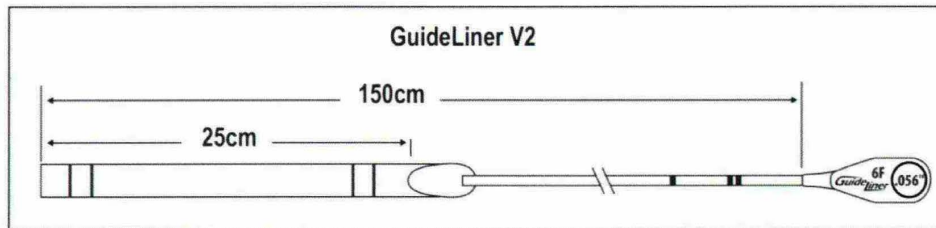
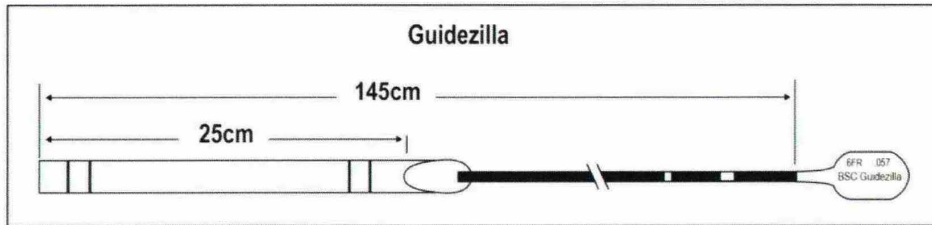

U.S. Patent Nov. 1, 2011 Sheet 1 of 13 US 8,048,032 B2

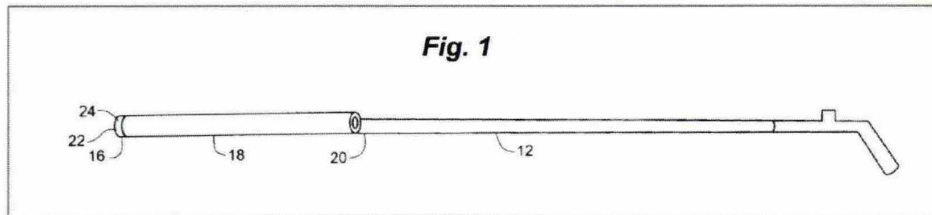

See Ex. 29.

71. The same as GuideLiner, the distal end of the Guidezilla is a relatively flexible tube with a lumen. The Guidezilla's flexible tube portion has the same three zones as GuideLiner: a very flexible blue tip, a less flexible blue portion, reinforced with

a braid, and further less flexible slightly darker blue portion made from a stiffer polymer as shown below:

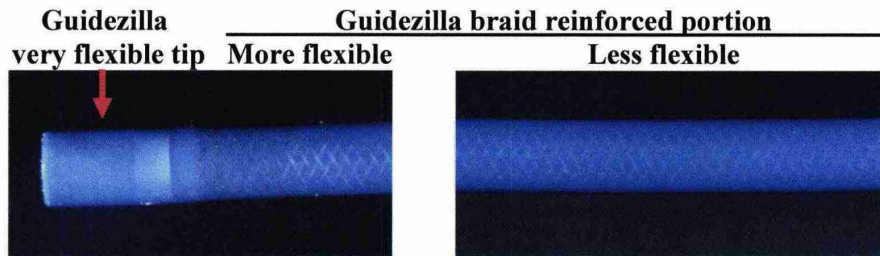

72. The same as GuideLiner V1, the flexible tube portion of Guidezilla is joined to a relatively inflexible metal collar where the lumen ends with a sloped opening:

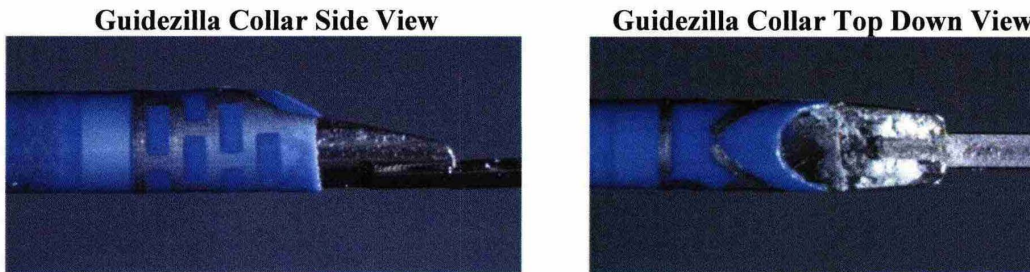

73. The same as GuideLiner V1, the metal collar of Guidezilla is then connected to a substantially rigid push rod that extends for the remainder of the length of the Guidezilla catheter:

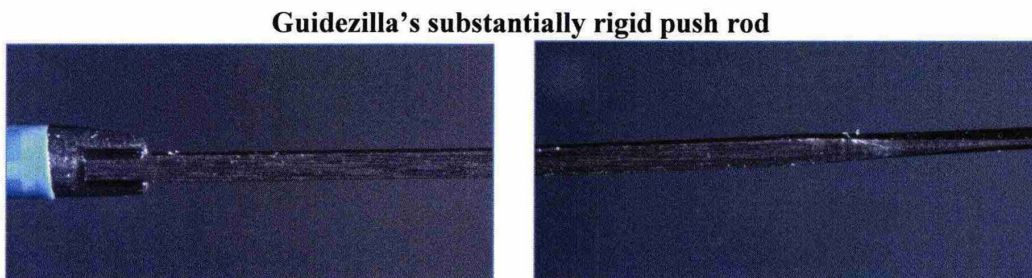

74. The same as GuideLiner, the proximal end of the push rod of Guidezilla is embedded into a tab which is used to identify the catheter and prevent it from being inadvertently pushed through the hemostatic valve:

Guidezilla proximal tab

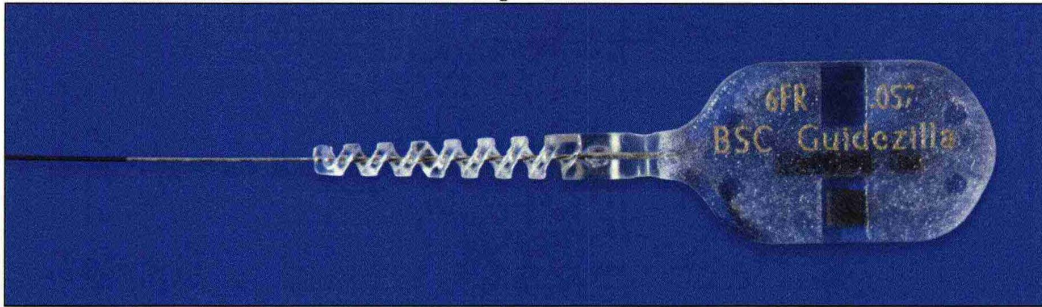

75. The construction of the flexible tip portion of the Guidezilla catheter provides the same guide extension functionality as the GuideLiner and as described and claimed in VSI's patents-in-suit. *See* Ex. 30. Because Guidezilla's flexible tip portion has a lumen, it allows medical devices such as stents to pass through the Guidezilla for placement in a coronary artery, the same as with GuideLiner.

Guidezilla flexible tip

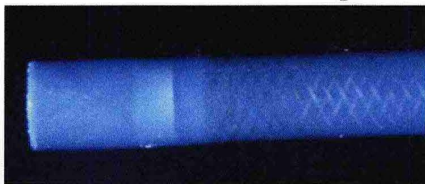

GuideLiner flexible tip

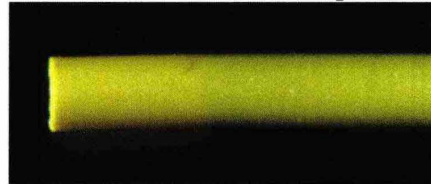

76. The construction of the collar portion of the Guidezilla catheter provides the same rapid exchange, or "rail," technology as VSI's GuideLiner catheter and as described and claimed in VSI's patents-in-suit. *See* Exs. 29, 30. The drawing and photographs

below show a comparison of the rapid exchange transition of the Guidezilla and VSI's GuideLiner catheters and Figure 1 of VSI's patents-in-suit:

U.S. Patent Nov. 1, 2011 Sheet 4 of 13 US 8,048,032 B2

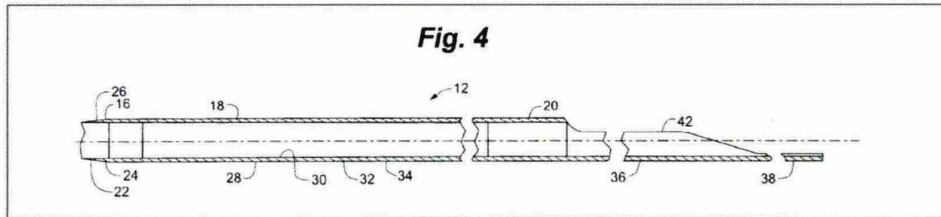

Guidezilla collar

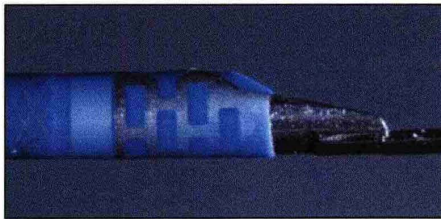

GuideLiner V1 collar



77. The construction of the push rod section of the Guidezilla catheter provides the same substantially rigid delivery without a lumen as VSI's GuideLiner catheter and as described and claimed in VSI's patents-in-suit. *See* Ex. 30. The Guidezilla push rod is made from a stainless steel hypotube, with the proximal end embedded in a plastic tab and has no opening.

Guidezilla substantially rigid portion

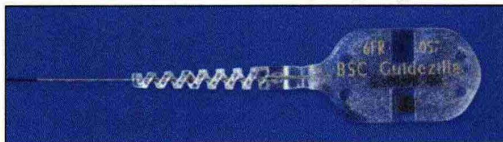

GuideLiner substantially rigid portion



78. The distal 2cm of the Guidezilla push rod section has been crushed flat and welded shut to the collar and has no opening. As a result, no medical device (or even a liquid or gas) can be delivered into or passed through Guidezilla's push rod.

Guidezilla "crushed" substantially rigid portion



GuideLiner substantially rigid portion



79. The construction and dimensions of the Guidezilla are an almost exact copy of the construction and dimensions of the GuideLiner as shown in the schematic below (see Ex. 29):

Guidezilla

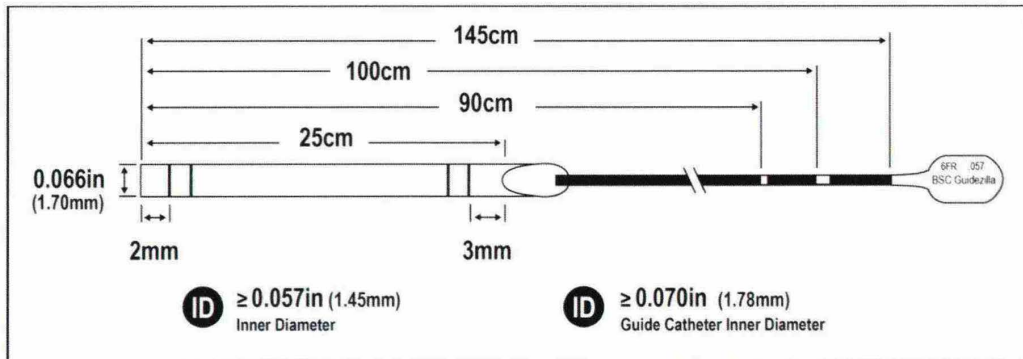

GuideLiner V2

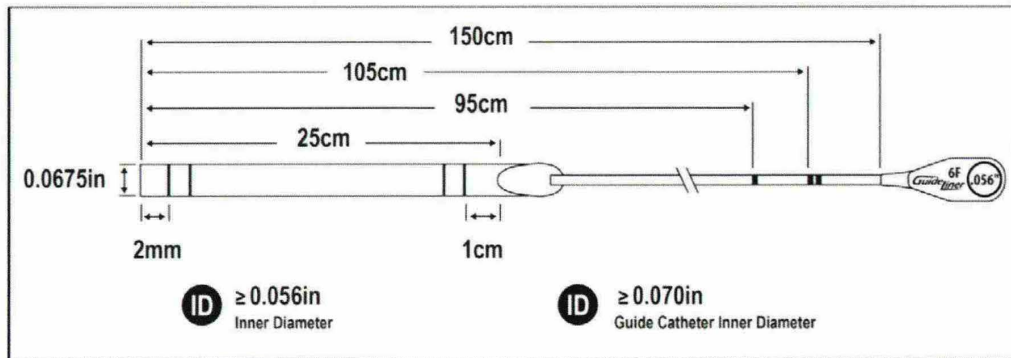

Boston Scientific's Guidezilla Catheter Infringes The VSI Patents

80. I have examined the Boston Scientific Guidezilla catheter and compared it to the claims of VSI's patents. As explained below and in the attached claim charts, the Guidezilla catheter infringes VSI's '032, '413, and '850 patents.

81. The Boston Scientific Guidezilla catheter meets every limitation of at least claims 1-8, 11-17, and 19 of the '032 patent. A claim chart showing my detailed comparison of the Guidezilla product to the limitations of the asserted claims of the '032 patent is attached as **Exhibit 31**.

82. By way of example, I have analyzed below claim 1 of the '032 patent as compared to Boston Scientific's Guidezilla catheter.

83. The preamble of the '032 patent, claim 1 describes a device for use with a standard guide catheter, as set forth below:

Preamble	Guidezilla
<p>A device for use with a standard guide catheter, the standard guide catheter having a continuous lumen extending for a predefined length from a proximal end at a hemostatic valve to a distal end adapted to be placed in a branch artery, the continuous lumen of the guide catheter having a circular cross-sectional inner diameter sized such that interventional cardiology devices are insertable into and through the lumen to the branch artery,</p>	<p>The Guidezilla Directions for Use (Ex. 25) indicate that the Guidezilla catheter is intended to be used in connection with a 6F standard guide catheter, which has a predefined length (100 cm) and a continuous lumen extending from a proximal end at a hemostatic valve to a distal end adapted to be placed in a branch artery, sized such that interventional cardiology devices such as balloons or stents are insertable into and through the lumen to the branch artery.</p>

84. Claim 1 of the '032 patent also requires that the device have a "flexible tip"

portion, as described below:

Flexible tip	Guidezilla
<p>a flexible tip portion defining a tubular structure having a circular cross-section and a length that is shorter than the predefined length that is shorter than the predefined length of the continuous lumen of the guide catheter, the tubular structure having a cross-sectional outer diameter sized to be insertable through the cross-sectional inner diameter of the continuous lumen of the guide catheter and defining a coaxial lumen having a cross-sectional inner diameter through which interventional cardiology devices are insertable,</p>	<p>The Guidezilla catheter has a flexible tip portion that defines a tubular structure with a circular cross-section. The Guidezilla catheter is described in the Directions for Use as a "single lumen rapid exchange catheter" through which interventional devices are insertable. (Ex. 25). The flexible tip portion is about 25 cm long and thus shorter than the 100 cm length of the continuous lumen of a standard guide catheter. The tubular structure has a cross-sectional outer diameter that allows it to be insertable in a standard guide catheter ("approximately 1 French smaller than the guide catheter"), and a cross-sectional inner diameter through which interventional cardiology devices are insertable.</p>

85. Claim 1 of the '032 patent also requires a "substantially rigid portion" as

described below:

Substantially rigid portion	Guidezilla
<p>a substantially rigid portion proximal of and operably connected to, and more rigid along a longitudinal axis than, the flexible tip portion and defining a rail structure without a lumen and having a maximal cross-sectional dimension at a proximal portion that is smaller than the cross-sectional outer diameter of the</p>	<p>The Guidezilla catheter has "a stainless steel proximal shaft" (Ex. 25) which is substantially rigid, proximal of and operably connected to, and more rigid than, the flexible tip portion. The shaft portion defines a rail structure, without a lumen (as discussed in detail below), and has a maximal cross-sectional</p>

<p>flexible tip portion and having a length that, when combined with the length of the flexible distal portion, defines a total length of the device along the longitudinal axis that is longer than the length of the continuous lumen of the guide catheter,</p>	<p>dimension at a proximal portion that is smaller than the cross-sectional outer diameter of the flexible tip portion.</p> <p>The rigid portion has a length that, when combined with the length of the flexible distal tip portion, defines a total length (145 cm) that is longer than the length of the continuous lumen of the guide catheter (100 cm).</p>
--	--

86. Claim 1 of the '032 patent also requires that the device be capable of being used for guide extension, as set forth below:

Guide extension	Guidezilla
<p>such that when at least a distal portion of the flexible tip portion is extended distally of the distal end of the guide catheter, at least a portion of the proximal portion of the substantially rigid portion extends proximally through the hemostatic valve in common with interventional cardiology devices that are insertable into the guide catheter.</p>	<p>When the distal end of the flexible tip portion is extended distally of the distal end of the guide catheter, at least a portion of the proximal portion of the substantially rigid portion (including the proximal tab) extends through the hemostatic valve.</p> <p>The Guidezilla 510(k) states that the Guidezilla “acts as an extension to a traditional catheter.” (Ex. 21)</p> <p>The Guidezilla Directions for Use instruct that the Guidezilla catheter be advanced up to a maximum of 15 cm “beyond the distal tip of the guide catheter” and advanced “through the hemostasis valve and into the guide catheter.” (Ex. 25)</p>

87. Similarly, I have performed an analysis of the other asserted claims of the '032 patent, and the Guidezilla catheter meets those claim limitations. *See* Ex. 31.

88. On June 3, 2013, counsel for Boston Scientific sent a letter to VSI's counsel, claiming that the Guidezilla catheter did not meet the requirement that the substantially rigid portion define a rail structure "without a lumen." According to Boston Scientific's counsel, the substantially rigid portion of the Guidezilla is formed from a hypotube that "has a continuous lumen running its entire length." This is the first substantive response of any kind that VSI has received from Boston Scientific. Attached as **Exhibit 32** is a true and correct copy of counsel's June 3, 2013 letter.

89. I have studied the substantially rigid portion (the push rod) of the Guidezilla device and Boston Scientific's instructional materials describing the same. The Guidezilla's pushrod is made of a stainless steel hypotube. A hypotube is an extremely thin hollow tube. The term "hypo" means "under", and a hypotube is generally thought of as a thin hollow tube that can be used to make a hypodermic needle that is placed under the skin.

90. With the Guidezilla hypotube, Boston Scientific has crushed flat its most distal two centimeters where it is welded to the collar. At the other end of the hypotube, Boston Scientific has embedded and sealed the hypotube into Guidezilla's plastic proximal tab. As a result, there is no opening to the space inside the hypotube to deliver any device through it or even into it. Furthermore, there is no space remaining inside the

hypotube for the final two centimeters where it has been crushed and welded to the collar.

The following photographs of the Guidezilla hypotube were taken at my direction.

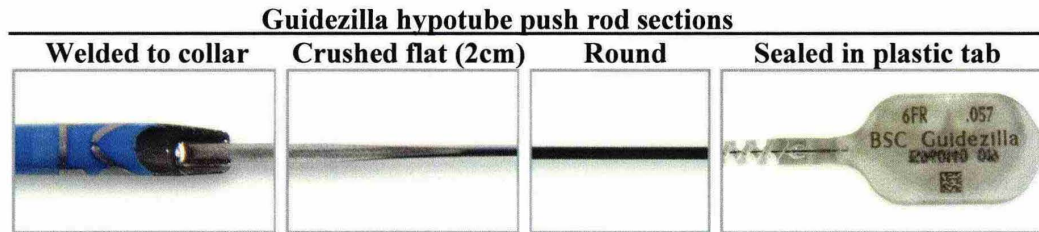

91. VSI's patents, all of which have a common specification, teach that the patented device's substantially rigid portion, or pushrod, can be formed from a hypotube. The patent contains this teaching in three different places. The patent states, "Rigid portion 20 may be formed from a hypotube or a section of stainless steel or Nitinol tubing." Ex. 2, col. 6, lns. 35-37; *see also id.* at col. 3, lns. 47-48 and col. 7, lns. 24-25.

92. As I understand the term "lumen" as used in the patents and in the field of interventional cardiology, it refers to the interior of a tubular structure, open at both ends to allow the passage of medical devices (for example, stents or balloons) and contrast medium. In the context of medical devices used in interventional cardiology, an inner cavity or void is not a lumen.

93. Definitions and usages from medical literature concerning medical devices are consistent with the discussion above. In the medical device context, "lumen" is defined as "the bore of a hollow needle, catheter, etc.," or "a hollow space, as in the bore of a hollow needle or in a bodily duct or tract." All of these medical devices allow some material, whether solid, liquid or gas, to pass through the lumen. Attached as **Exhibit 33** are true and correct copies of these definitions.

94. Attached as **Exhibit 34** are true and correct copies of literature from the field of interventional cardiology, marked up to show the use of the term “lumen.” These uses of the term “lumen” are consistent with my understanding of the term.

95. Boston Scientific also uses the term “lumen” with its other products in this same way. Attached as **Exhibit 35** is a true and correct copy of excerpts from Boston Scientific’s website.

96. The claims of the VSI patents themselves state that a lumen allows interventional cardiology devices to pass through the lumen to reach the artery. Claim 1 of the ‘032 patent (Ex. 2) recites:

- “the continuous lumen of the guide catheter having a circular cross-sectional inner diameter sized such that interventional cardiology devices are insertable into and through the lumen to the branch artery”; and
- “a flexible tip portion defining a tubular structure . . . defining a coaxial lumen [with the guide catheter] having a cross-sectional inner diameter through which interventional cardiology devices are insertable.”

97. In addition, all other independent claims of the VSI patents contain this same type of language. Claim 1 of the ’413 patent, for example, recites, “advancing the interventional cardiology device through and beyond a lumen of the flexible tip portion into contact with or past a lesion in the second artery.” Ex. 3.

98. The specification of the three VSI patents uses the term “lumen” to refer to a passage through which interventional cardiology devices are able to pass, so that the device can reach the arterial site. This usage starts with the Abstract. The ‘032 patent’s Abstract states,

The coaxial guide catheter is extended through the lumen of the guide catheter and beyond the distal end of the guide catheter and inserted into the branch artery. The device assists in resisting axial and shear forces exerted by an interventional cardiology device passed through the second lumen and beyond the flexible distal tip portion that would otherwise tend to dislodge the guide catheter from the branch artery.

The remainder of the specification also uses “lumen” in this manner. For example, the ‘032 patent states:

- “a guidewire or other instrument is passed through the lumen of the guide catheter and inserted into the artery beyond the occlusion or stenosis,” Ex. 2, col. 1, lns. 32-36;
- “Both the straight portion and the tapered portion are pierced by a lumen through which a guidewire may be passed.” Ex. 2, col. 4, lns. 2-4;
- “the lumen that passes through the straight portion and the tapered portion,” Ex. 2, col. 4, lns. 5-7;
- “tapered portion 46 and straight portion 48 are pierced by lumen 50,” Ex. 2, col. 6, lns. 60-61; and
- “An interventional cardiology treatment device such as a catheter bearing a stent or a balloon (not shown) is then inserted through the lumen of coaxial guide catheter 12 which remains inside guide catheter 56.” Ex. 2, col. 9, lns. 59-63.

99. The phrase “defining a rail structure without a lumen” was added to the claims at the end of prosecution of the ‘032 patent. I attach as **Exhibits 36-38** file history excerpts showing the addition of that language to the claims of all three patents.

100. The use of the term “lumen” in the VSI patents distinguishes VSI’s invention from prior OTW guide catheter extensions. With OTW guide catheter extensions (such as Terumo’s Heartrail), medical devices (such as stents) are passed through the child catheter’s lumen, which runs the entire length of the catheter. VSI’s invention, however, provides that medical devices are only passed through the lumen of

the distal flexible tip portion, and not through the proximal push rod. Therefore, with VSI's invention the substantially rigid push rod is "defining a rail structure without a lumen" because it does not provide for the delivery of medical devices through the push rod. Instead, the substantially rigid portion, or the push rod, is used only to push the flexible tip over a guidewire and through the guide catheter. When VSI's invention is used, interventional and other devices are able to pass through the guide catheter next to, but not through, the substantially rigid portion.

101. As part of any medical device sold in the U.S., the manufacturer must write, approve and supply with every device shipped a document known either as the Instructions for Use, or sometimes referred to as Directions for Use. In the "Device Description" section of the Directions for Use for Guidezilla, Boston Scientific described the Guidezilla catheter as "a single lumen rapid exchange catheter" "with a 25cm single lumen distal guide segment" through which interventional devices are insertable. (Ex. 25). By stating in an FDA-required and corporate-approved document that there is only a single lumen in the Guidezilla catheter and that the single lumen is the distal flexible 25cm section, Boston Scientific's regulatory, marketing and business managers recognized that the Guidezilla push rod does not have a lumen, because nothing can be inserted into or through it.

102. Even with the cavity that exists in its hypotube, the Guidezilla's substantially rigid portion is substantially the same as the substantially rigid portion claimed in the VSI patent claims. The existence of Guidezilla's cavity sealed at both ends makes no practical or functional difference to the patent's "substantially rigid

portion . . . defining a rail structure without a lumen” since it performs substantially the same function, in substantially the same way, to obtain the same result, as the claim element of a substantially rigid portion. The Guidezilla’s substantially rigid portion, like the claim element of the substantially rigid portion, is insertable through the hemostatic valve, is used to push the Guidezilla’s flexible tip portion over the guidewire and through the guide catheter, allows for rapid exchange, and is a “rail” system in contrast to the “over the wire” system described in detail above.

103. Because nothing can pass through the cavity in the Guidezilla’s substantially rigid portion, it does not in any way function as a “lumen,” and indeed serves no functional purpose. The Guidezilla catheter’s substantially rigid portion thus provides the exact same functional result, in the exact same way, to achieve the same result as the “substantially rigid portion. . . defining a rail structure without a lumen” set forth in the claims.

The Guidezilla’s Infringement of the ‘413 and ‘850 Patents

104. Boston Scientific’s Guidezilla catheter, when used as intended and as directed by Boston Scientific in its Directions for Use and elsewhere, also meets every limitation of at least claims 1, 2, 4, 5, and 7-13 of the ‘413 patent. A claim chart showing my detailed comparison of the Guidezilla catheter and Boston Scientific’s directions for using the Guidezilla catheter to the limitations of the asserted claims of the ‘413 patent is attached as **Exhibit 39**. The Guidezilla catheter is specially made for uses covered by the asserted claims of the ‘413 patent, it is not a staple article of commerce, and it is not suitable for any substantial noninfringing use.

105. Boston Scientific's Guidezilla catheter, when used with a standard guide catheter as directed by Boston Scientific, meets every limitation of at least claims 1-8, 12-18, and 20 of the '850 patent. A claim chart showing my detailed comparison of the Guidezilla catheter to the limitations of the asserted claims of the '850 patent is attached as **Exhibit 40**. The Guidezilla catheter is specially made for use as part of a system covered by the asserted claims of the '850 patent, it is not a staple article of commerce, and it is not suitable for any substantial noninfringing use.

106. I know that Boston Scientific is aware of the VSI patents, because I sent a letter to Mr. Ballinger in October 2012 bringing VSI's patents-in-suit to Boston Scientific's attention. As explained in Exhibits 39 and 40, following the Boston Scientific Directions for Use necessarily results in infringement of the '413 and '850 patents. The Guidezilla catheter has no uses other than to practice the VSI patents. As discussed in Exhibit 39, the Guidezilla catheter is designed and intended, and as instructed by Boston Scientific, for use with the method claimed in VSI's '413 patent. As further discussed in Exhibit 40, the Guidezilla catheter is designed and intended, and as instructed by Boston Scientific, for use with a guide catheter, thereby necessarily resulting in a system that infringes VSI's '850 patent.

VSI Will Continue to Suffer Irreparable Harm Until Boston Scientific's Sales of the Guidezilla Catheter Are Enjoined

107. Before Boston Scientific introduced its infringing Guidezilla product, VSI's patented GuideLiner catheter was a one of a kind product, the only guide extension catheter using rail technology. According to physicians using the product, the

GuideLiner had “no competitor device.” Thus, in 2009, VSI created a new market in which it had no competitors.

108. I understand that Boston Scientific has only recently begun marketing its Guidezilla catheter, and is providing the product to certain physicians for clinical use and evaluation across the country and in Europe.

109. Boston Scientific has the resources to cause substantial and irreparable harm to VSI between now and the time of trial. Boston Scientific has substantially greater resources than VSI to devote to sales efforts and it has many more products and relationships that it can leverage to displace sales of GuideLiner with sales of Guidezilla. Because Boston Scientific copied VSI’s product, rather than investing in the R&D necessary to develop its own, and because VSI already invested substantially in the education of physicians worldwide regarding its innovative product, Boston Scientific will be able to quickly reap the benefit of VSI’s substantial investment.

110. The GuideLiner catheter is VSI’s fastest-growing product, and represents approximately 20% of VSI’s annual sales revenue. VSI’s ability to continue to increase GuideLiner catheter sales and maintain its exclusive market position is extremely important to VSI. If Boston Scientific is allowed to sell its infringing Guidezilla product in competition with VSI over the next 12-18 months, VSI will suffer severe and irreversible harm that cannot be compensated by a money judgment. I explain below the various harms that are likely to result if Boston Scientific’s infringement is not stopped.

111. Irreparable distraction of VSI’s sales force. VSI’s sales force will be forced to devote substantial time and attention to deal with Boston Scientific’s competition. Our

salespeople will necessarily have to try to retain their existing GuideLiner customers against the competition (when none previously existed), rather than seeking new customers or selling additional VSI products. Even after the Guidezilla catheter is off the market, the sales force will have to spend time gaining back the lost accounts. It is not possible to quantify how many additional VSI products could have sold if Boston Scientific had not been allowed to continue infringing because the VSI sales force has to spend time dealing with Boston Scientific's copycat product.

112. Irreparable price erosion. Boston Scientific's market dominating size and large portfolio of other products will allow it to undercut VSI's price for the GuideLiner catheter. Boston Scientific can easily charge a lower price for its Guidezilla catheter, since it is a copy of VSI's device and Boston Scientific did not have to invest in developing its own product. Boston Scientific has many other products which it can bundle with the Guidezilla catheter, thereby lowering the Guidezilla pricing for the customer but making up the shortfall on other products Boston Scientific sells. Because of its size, Boston Scientific also can withstand reduced pricing on a small revenue product (for it) like Guidezilla to take market share from the much smaller VSI where GuideLiner sales matter to a much higher degree. Boston Scientific's infringement will completely alter the pricing structure of the market for VSI's GuideLiner catheter, in ways that cannot be measured and compensated for by a money judgment 12-18 months from now.

113. Boston Scientific is already undercutting VSI on price, even during its early marketing of the Guidezilla product. I learned from a VSI account manager, James

Capizzuto, that on May 7, 2013, he visited Columbia Presbyterian Hospital in New York, which until that time was one of VSI's largest GuideLiner accounts. Capizzuto told me that he witnessed the Cardiac Catheterization Laboratory manager with a Boston Scientific representative comparing Guidezilla brochures and GuideLiner brochures on a computer, and then comparing product pricing in the inventory system. Capizzuto subsequently confirmed that Boston Scientific had undercut VSI's price by \$29 per unit, and that Columbia Presbyterian loaded Boston Scientific's Guidezilla 6F catheter into its inventory system for purchase.

114. If Boston Scientific is allowed to continue to infringe, VSI will almost certainly be forced to lower its GuideLiner catheter prices, in order to try to maintain market share. Once VSI lowers its pricing on its GuideLiner catheters, VSI will not be able to easily raise its prices again if an injunction is issued 12-18 months from now. VSI's customers are under substantial pressure to cut costs, and many of them will resist future price increases once a price has been lowered. It is not possible to quantify or predict how long this effect will last, or how much harm it will cause VSI.

115. Loss of associated sales of other VSI products. The GuideLiner catheter is VSI's most visible product, giving VSI greater credibility and opening the door into virtually every cardiac catheterization lab in the United States. As explained above in Paragraph 42 and Exhibit 41 (filed under seal), VSI has gained many new customers because of the GuideLiner catheter, and has been able to sell those new customers many other VSI products, generating substantial sales revenue.

116. The infringing competition from the Guidezilla catheter will hamper VSI's efforts to gain and maintain customer relationships. If customers are buying the Guidezilla catheter, VSI will lose not only the sales of the GuideLiner catheter, but also the sales of other VSI products we could have sold, if our salespeople had been able to form and maintain relationships with those customers. In my judgment, it is not possible to quantify 12-18 months from now how many new customers we could have gained or customers for other VSI products we would have kept but for Boston Scientific's infringement, nor is it possible to quantify the loss of sales revenue. At a minimum, such losses will be extremely difficult to quantify to a reasonable degree of certainty, which I understand to be the legal standard we would have to meet.

117. Lack of revenue to fund R&D. VSI's practice is to allocate 10-12% of revenue for research and development. This R&D spending is critical to the company's long-term health, as without investment in R&D, VSI will not have new and improved products to sell. No medical device company can survive, let alone prosper, without new and improved products, as our competitors are constantly attempting to innovate as well.

118. Currently, the GuideLiner catheter revenues are 20% of VSI's sales, and growing very quickly. If those sales fail to grow as projected because of Boston Scientific's infringement, VSI will have to reduce its planned investment in research and development. That reduction would necessarily reduce VSI's hiring of new employees, and if the reduction is severe enough, could require lay-offs.

119. The reduction in R&D investment will harm VSI in ways that cannot be calculated, because it is not possible to quantify how current investment in R&D results

in long-term sales revenue from new and improved products. At a minimum, it is not possible to quantify such harm to a reasonable degree of certainty required for a damages award.

120. Sales force attrition. VSI employs 91 sales employees, largely comprised of account managers, in the United States. Our sales force is the lifeblood of our business, as a good sales force is critical to VSI's ability to sell its products.

121. Our account managers are responsible for selling VSI's products directly to physicians – principally to interventional cardiologists who use the majority of our products. VSI's account managers, over time, develop relationships with their physician customers, as well as with the nurses, lab technicians, and purchasing managers, who are often involved in the buying decision.

122. VSI's sales force has to have a thorough understanding of VSI's products, as well as the needs of VSI's current customers, in order to successfully sell VSI's products. Account managers are often present during a medical procedure using a VSI product to explain the functionality of the particular medical device they are selling and servicing. The majority of VSI's sales representatives have some clinical experience or qualifications.

123. VSI substantially invests in sales force training and retention. VSI conducts multiple training sessions each year for its sales employees, and holds a World Sales Meeting once a year. During these training sessions, account managers are instructed on how VSI's products are used in the medical field, how they compare to competitors' products, and techniques for selling VSI's products to physicians and hospitals.

124. A substantial part of the account managers' compensation is based on sales commissions and bonuses for hitting sales and growth targets. If GuideLiner sales decline due to Boston Scientific's infringing product sales, commissions and bonus payments to VSI's account managers will decline.

125. In my experience, lower compensation for sales employees causes significant attrition. For example, in 2001-2003, when VSI's sales of its first product, the Duett, did not grow as expected, we had more than 100% turnover in our sales force over a two year period of time. Based on that experience and my knowledge of the industry, I believe that even a short period of infringement by Boston Scientific will result in VSI losing some, and possibly a substantial number, of its sales employees.

126. One harmful and hard-to-quantify effect of losing sales employees is the loss of the relationships those employees have formed with their customers. Customer relationships are personal, and can last for many years. VSI account managers are not only sales personnel, but also provide their customers with training, information, and support. In most cases, those customers purchase multiple products from their VSI Account Manager. Thus, the loss of a relationship opens the door – not just for Boston Scientific to sell its infringing Guidezilla products, but for other companies selling products competing with other VSI products. It would be extremely difficult to identify, or quantify the value of, those lost customer relationships at the time of trial.

127. In addition, VSI must replace its lost sales employees. It takes up to four years to fully train a new sales employee on all of VSI's more than seventy-five products before he or she is completely proficient. In addition to VSI's added training costs, an

untrained Account Manager, just beginning to form relationships with customers, is unlikely to be as successful selling the GuideLiner product and VSI's other products. Boston Scientific's infringing Guidezilla device will cause long-lasting or permanent damage to VSI's sales structure and sales force, which has taken years for VSI to build.

128. VSI's reputation will change from innovator to competitor. Before Boston Scientific's Guidezilla product came into the market, VSI had the only catheter that combined the benefits of guide extension with rail technology. This unique product gave a tremendous boost to VSI's reputation as an innovative company. Boston Scientific's entry will change the market from a single player with an exclusive, patented product to one with a copycat product being sold by a major competitor. VSI will lose its market exclusivity, changing the market's perception of VSI and affecting VSI's credibility as an innovator in a way that cannot be reversed 12-18 months from now when Boston Scientific's product sales are enjoined.

129. Negative effects on VSI's stock price. VSI is a public company, and its stock price depends in significant part on our ability to continue VSI's track record of increasing sales and profitability. VSI has increased sales by more than 10% in each of the last nine years, and I expect that growth to continue in 2013. Without growth in GuideLiner sales, however, a 10% annual growth rate would be unlikely, and VSI's stock price will either decline or not increase as much as it would otherwise as a result of Boston Scientific's infringement.

130. As a public company, VSI's stock price is an important factor in our ability to grow, by attracting talented new employees, rewarding current employees with stock-

based compensation, and using our stock to make potential future acquisitions to build VSI's business. Those harms from a declining or even not increasing stock price cannot be adequately measured or compensated through a damages award for lost sales or a reasonable royalty years from now.

I declare under the penalty of perjury that the foregoing is true and correct.

Executed on June 10, 2013, in Hennepin County, Minnesota.

s/ Howard Root
Howard Root