

UNITED STATES PATENT AND TRADEMARK OFFICE

BEFORE THE PATENT TRIAL AND APPEAL BOARD

MEDTRONIC, INC. AND MEDTRONIC VASCULAR, INC.,
Petitioner,

v.

TELEFLEX INNOVATIONS S.À.R.L.,
Patent Owner.

IPR2020-00130
Patent RE45,380

Before SHERIDAN K. SNEDDEN, JON B. TORNQUIST, and
CHRISTOPHER G. PAULRAJ, *Administrative Patent Judges*.

TORNQUIST, *Administrative Patent Judge*.

DECISION
Granting Institution of *Inter Partes* Review
35 U.S.C. § 314

INTRODUCTION

Medtronic, Inc. and Medtronic Vascular, Inc. (collectively “Petitioner”) filed a Petition (Paper 1, “Pet.”) requesting an *inter partes* review of claims 1–4, 6–9, and 12–21 of U.S. Reissue Patent RE45,380 (Ex. 1401, “the ’380 patent”). Teleflex Innovations S.À.R.L. (“Patent Owner”) filed a Preliminary Response to the Petition (Paper 9, “Prelim. Resp.”). Pursuant to our authorization, Petitioner filed a Reply (Paper 14) addressing its burden on secondary considerations and reduction to practice, and Patent Owner filed a Sur-Reply (Paper 15) addressing Petitioner’s burden on those issues. Also pursuant to our authorization, Petitioner filed another Reply (Paper 17) and Patent Owner filed another Sur-Reply (Paper 18) addressing the factors for discretionary denial under 35 U.S.C. § 314(a).

We have authority to determine whether to institute an *inter partes* review. 35 U.S.C. § 314 (2018); 37 C.F.R. § 42.4(a) (2019). The standard for institution is set forth in 35 U.S.C. § 314(a), which provides that an *inter partes* review may not be instituted “unless the Director determines . . . there is a reasonable likelihood that the petitioner would prevail with respect to at least 1 of the claims challenged in the petition.”

After considering the parties’ arguments and evidence, we determine that Petitioner has demonstrated a reasonable likelihood that it would prevail with respect to at least one of the claims challenged in the Petition.

Accordingly, we institute an *inter partes* review of all challenged claims and all asserted grounds set forth in the Petition. *See SAS Inst. Inc. v. Iancu*, 138 S. Ct. 1348, 1355–56 (2018); *PGS Geophysical AS v. Iancu*, 891 F.3d 1354, 1360 (Fed. Cir. 2018) (interpreting the statute to require “a simple yes-

or-no institution choice respecting a petition, embracing all challenges included in the petition”).

A. Related Matters

The parties indicate that the ’380 patent is the subject of litigation in *Vascular Solutions LLC, et al. v. Medtronic, Inc., et al.*, No. 19-cv-01760 (D. Minn.) (“*Medtronic case*”) and *QXMedical, LLC v. Vascular Solutions, LLC*, No. 17-cv-01969 (D. Minn) (“*QXM case*”). Pet. 4–5; Paper 4, 2. The ’380 patent is also at issue in IPR2020-00128, IPR2020-00129, and IPR2020-00131. Paper 4, 2–3; Pet. 5. We instituted *inter partes* review in IPR2020-00128 and IPR2020-00129 on June 8, 2020. IPR2020-00128, Paper 22; IPR2020-00129, Paper 22.

B. The ’380 Patent

The ’380 patent relates to catheters used in interventional cardiology procedures and, in particular, to “methods and apparatus for increasing backup support for catheters inserted into the coronary arteries from the aorta.” Ex. 1401, 1:31–35.

“In coronary artery disease the coronary arteries may be narrowed or occluded by atherosclerotic plaques or other lesions.” *Id.* at 1:44–46. This narrowing is referred to as stenosis. *Id.* at 1:48–49. To treat this stenosis, “it is commonly necessary to pass a guidewire or other instruments through and beyond the occlusion or stenosis of the coronary artery.” *Id.* at 1:49–52. In this method, a guide catheter is inserted through the aorta and into the ostium of the coronary artery where it is typically seated into the opening or ostium of the artery to be treated. *Id.* at 1:53–57. A guidewire or other instrument is then passed through the lumen of the guide catheter and inserted into the artery beyond the stenosis. *Id.* at 1:39–41, 1:57–59.

Crossing the tough lesions, however, may create enough backwards force to dislodge the guide catheter from the ostium of the artery being treated, making it difficult or impossible to treat certain forms of coronary artery disease. *Id.* at 1:59–63.

Figures 1 and 2 of the '380 patent are reproduced below:

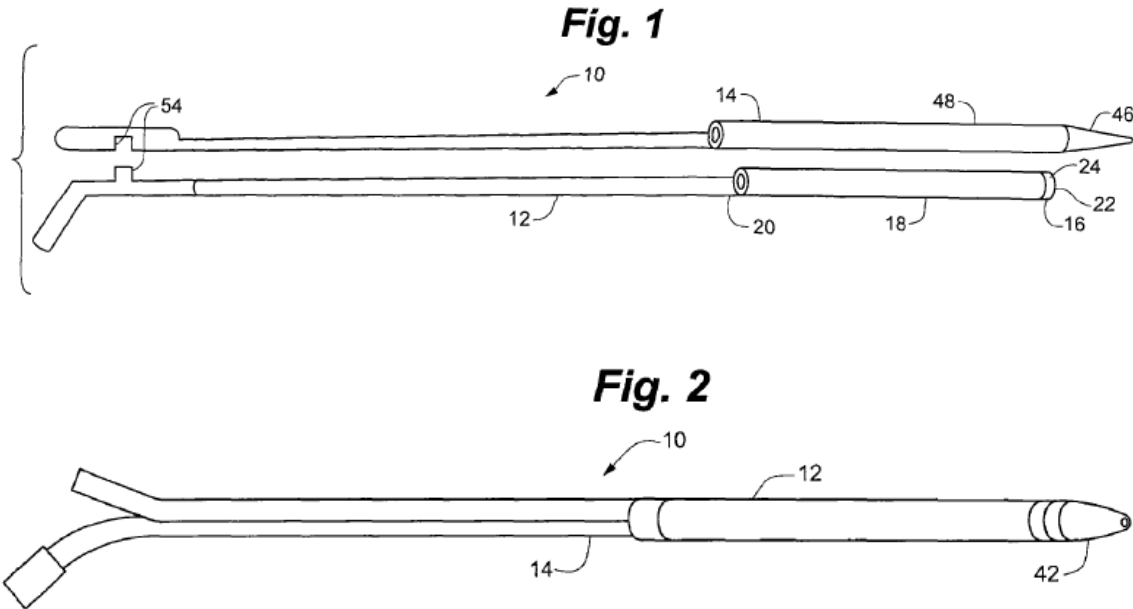

Figure 1 is a schematic depiction of a coaxial guide catheter and a tapered inner catheter and Figure 2 is a schematic depiction of these two elements assembled. *Id.* at 5:40–45. As shown in Figure 1, coaxial guide catheter 12 includes tip portion 16, reinforced portion 18, and rigid portion 20. *Id.* at 6:34–35. Tapered inner catheter 14 includes tapered portion 46 at a distal end thereof and straight portion 48. *Id.* at 7:16–17. Clip 54 releasably joins tapered inner catheter 14 to coaxial guide catheter 12. *Id.* at 7:21–23.

Figure 8 of the '380 patent is reproduced below:

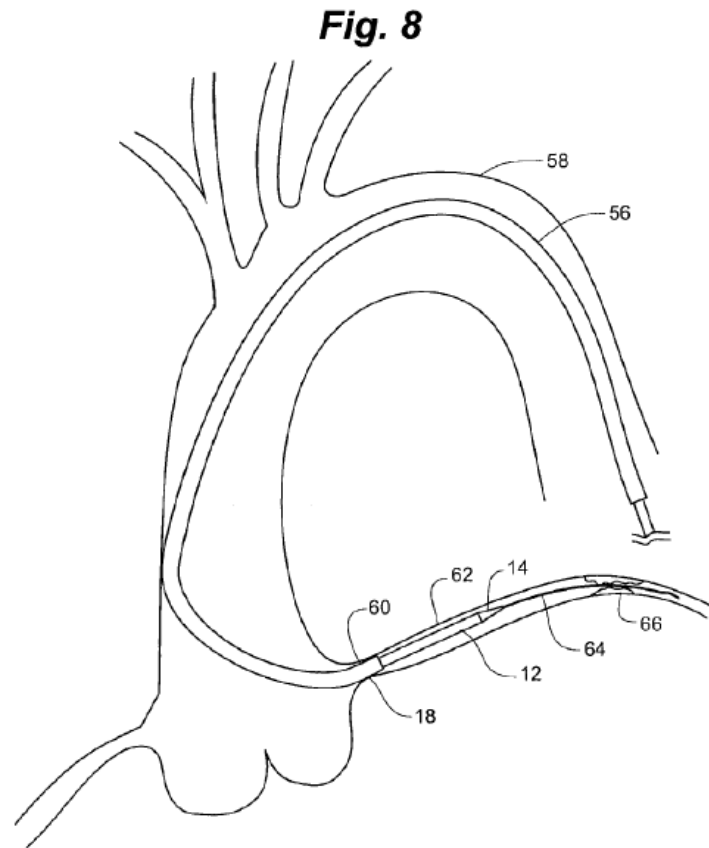

Figure 8 is a schematic view of a guide catheter, a guidewire, a coaxial guide catheter, and a tapered inner catheter located in the aortic arch and coronary artery. *Id.* at 5:61–64. In Figure 8, “coaxial guide catheter 12 with tapered inner catheter 14 is passed through guide catheter 56 and over guidewire 64 into coronary artery 62 after the guide catheter 56 has been placed in the ostium 60 of coronary artery 62.” *Id.* at 8:6–10. “Coaxial guide catheter 12, with tapered inner catheter 14, provides an inner support member for proper translation over guidewire 64.” *Id.* at 8:10–14. “Once coaxial guide catheter 12 is in place, tapered inner catheter 14 is removed from the inside of coaxial guide catheter 12.” *Id.* at 8:14–17. At this point, coaxial guide catheter 12 is ready to accept a treatment catheter such as a stent or balloon

Explore Litigation Insights

Docket Alarm provides insights to develop a more informed litigation strategy and the peace of mind of knowing you're on top of things.

Real-Time Litigation Alerts



Keep your litigation team up-to-date with **real-time alerts** and advanced team management tools built for the enterprise, all while greatly reducing PACER spend.

Our comprehensive service means we can handle Federal, State, and Administrative courts across the country.

Advanced Docket Research



With over 230 million records, Docket Alarm's cloud-native docket research platform finds what other services can't. Coverage includes Federal, State, plus PTAB, TTAB, ITC and NLRB decisions, all in one place.

Identify arguments that have been successful in the past with full text, pinpoint searching. Link to case law cited within any court document via Fastcase.

Analytics At Your Fingertips



Learn what happened the last time a particular judge, opposing counsel or company faced cases similar to yours.

Advanced out-of-the-box PTAB and TTAB analytics are always at your fingertips.

API

Docket Alarm offers a powerful API (application programming interface) to developers that want to integrate case filings into their apps.

LAW FIRMS

Build custom dashboards for your attorneys and clients with live data direct from the court.

Automate many repetitive legal tasks like conflict checks, document management, and marketing.

FINANCIAL INSTITUTIONS

Litigation and bankruptcy checks for companies and debtors.

E-DISCOVERY AND LEGAL VENDORS

Sync your system to PACER to automate legal marketing.