



US008132105B1

(12) **United States Patent**
Dubil et al.

(10) **Patent No.:** **US 8,132,105 B1**
(45) **Date of Patent:** **Mar. 6, 2012**

(54) **CONTROL CODES FOR PROGRAMMABLE
REMOTE SUPPLIED IN XML FORMAT**

(75) Inventors: **Thomas James Dubil**, Morgan Hill, CA (US); **Stuart Peter McKechnie**, Saratoga, CA (US); **Rudy Musschebroeck**, Jette (BE); **Yevgeniy Eugene Shteyn**, Cupertino, CA (US); **Stefaan M. Note**, Berchem (BE); **Frank Louis Boghe**, Sunnyvale, CA (US)

(73) Assignee: **Koninklijke Philips Electronics, N.V.**, Eindhoven (NL)

(*) Notice: Subject to any disclaimer, the term of this patent is extended or adjusted under 35 U.S.C. 154(b) by 629 days.

(21) Appl. No.: **09/686,572**

(22) Filed: **Oct. 10, 2000**

(51) **Int. Cl.**
G06F 3/00 (2006.01)

(52) **U.S. Cl.** **715/740**; 715/748; 715/749; 715/760; 715/716

(58) **Field of Classification Search** 345/740, 345/748, 749, 760, 716; 700/19, 20, 17, 700/83; 341/175, 176, 169; 571/740, 748, 571/749, 760, 716

See application file for complete search history.

(56) **References Cited**

U.S. PATENT DOCUMENTS

5,898,838	A	4/1999	Wagner	
5,963,264	A *	10/1999	Jackson	348/460
6,104,334	A *	8/2000	Allport	341/175
6,111,569	A *	8/2000	Brusky et al.	345/327
6,133,847	A *	10/2000	Yang	340/825.22
6,157,319	A *	12/2000	Johns et al.	340/825.72
6,344,769	B1	2/2002	Giuroiu	
6,374,296	B1 *	4/2002	Lim et al.	709/225

6,397,186	B1 *	5/2002	Bush et al.	704/274
6,401,059	B1 *	6/2002	Shen et al.	703/27
6,407,594	B1	6/2002	Milazzo et al.	
6,407,779	B1 *	6/2002	Herz	348/734
6,431,875	B1 *	8/2002	Elliott et al.	434/322
6,437,836	B1 *	8/2002	Huang et al.	348/734
6,446,192	B1 *	9/2002	Narasimhan et al.	712/29
6,466,233	B1 *	10/2002	Mitani	345/716
6,466,971	B1 *	10/2002	Humpleman et al.	709/220
6,546,419	B1 *	4/2003	Humpleman et al.	709/223
6,606,280	B1 *	8/2003	Knittel	367/198
6,769,129	B1 *	7/2004	Perlman	725/80
6,956,496	B1 *	10/2005	Herz	340/825.22
7,130,895	B2 *	10/2006	Zintel et al.	709/220
2001/0002115	A1	5/2001	Hwang et al.	
2001/0005197	A1 *	6/2001	Mishra et al.	345/100
2002/0042915	A1 *	4/2002	Kubischta et al.	725/38
2004/0090315	A1 *	5/2004	Mackjust et al.	340/426.13
2005/0052423	A1 *	3/2005	Harris et al.	345/169
2006/0200253	A1 *	9/2006	Hoffberg et al.	700/19

FOREIGN PATENT DOCUMENTS

WO	99/57649	11/1999
WO	0017738	A1 3/2000

OTHER PUBLICATIONS

“A Process and Tools for Multi-Modal Authoring of Web Content”, *Research Disclosure* Jun. 1999, pp. 887-888.
Signal: Position Statement: Intelligent Control Via the Web; Future of Embedded Internet-Embedded Workshop; Year Unknown, 2 page Document.

* cited by examiner

Primary Examiner — William L Bashore
Assistant Examiner — Mylinh Tran

(57) **ABSTRACT**

An Internet service makes available control codes for use on a programmable universal remote. The remote controls CE equipment through IR or RF commands. A server supplies the control codes as XML data that gets processed at the receiver's set top box or PC, or the remote itself, for being properly installed on the remote.

7 Claims, 1 Drawing Sheet

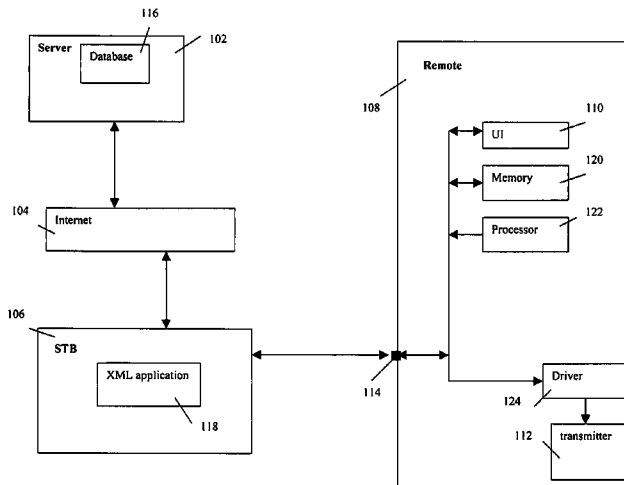

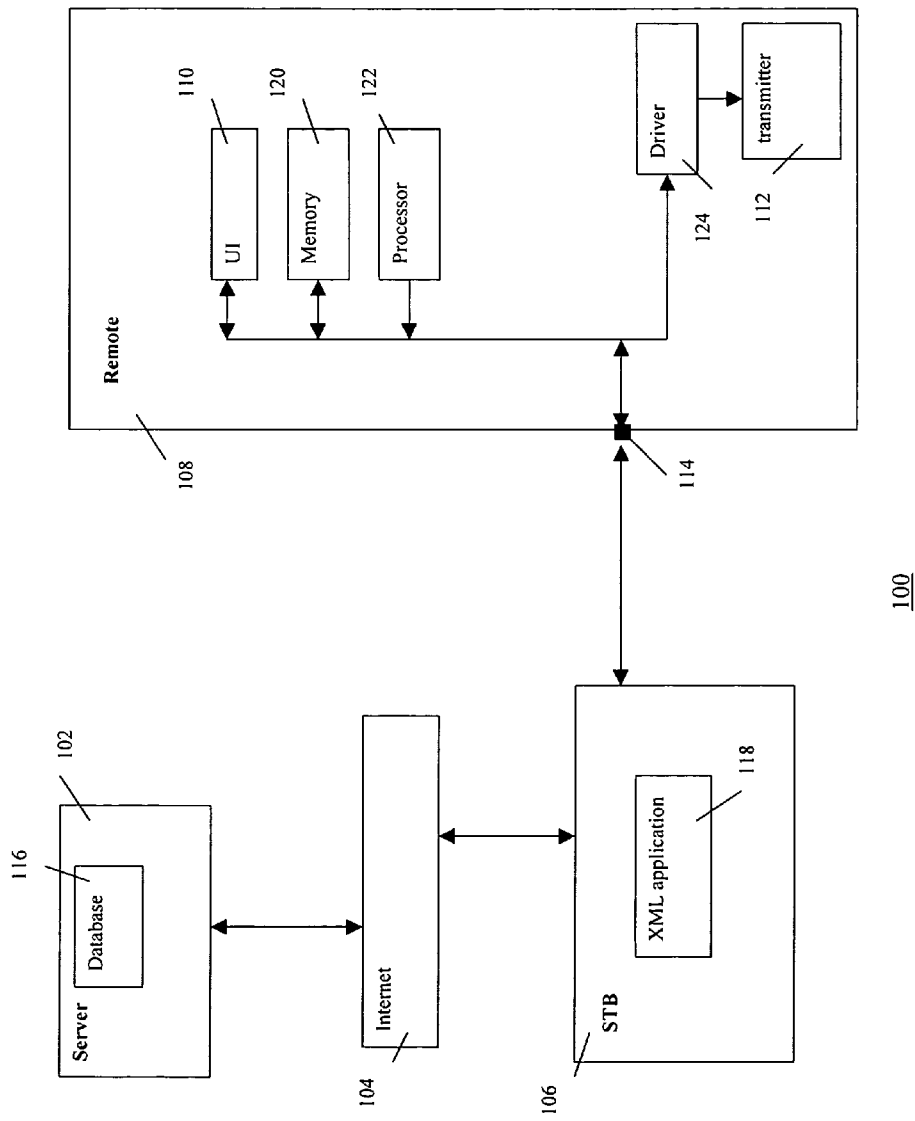

Fig.1

1

CONTROL CODES FOR PROGRAMMABLE REMOTE SUPPLIED IN XML FORMAT

FIELD OF THE INVENTION

The invention relates to remote control devices and to a service for enabling the programming of remote controls to be used with consumer electronics (CE) equipment.

BACKGROUND ART

Universal programmable remote control devices, e.g., the PRONTO™ made by Philips Electronics, are well known. The expression “universal remote” indicates a device that enables the end-user to control the majority of his/her collection of remotely controllable apparatus, regardless of the type or brand of the individual apparatus. This universal controllability is achieved, e.g., by accommodating on the remote a data base of multiple sets of existing control (IR or RF) codes, each particular set being associated with a particular type of apparatus of a particular brand. The universal remote is user-programmable and capable of learning or adopting new control codes and of associating them with a particular user-defined soft key or hard button. The PRONTO™, for example, has built-in RC-5 and RC-6 codes for Philips and Marantz equipment, IR-sending and IR-receiving eyes, and an RS232 serial port connector for after-market expansibility of the codes, e.g., via a PC. The PRONTO™ provides a GUI via an LCD touch screen and also has direct-access buttons for frequently used control functions. Built-in are customizable device templates for full control; the options to assign control functions to icons or buttons; options to delete and create icons or buttons; options to program and edit macros; a keyboard with soft keys for (re-) labeling buttons, icons and templates or the GUI's control panels. In short, the PRONTO™ is highly customizable in terms of the GUI's lay-out, appearance, labeling, organization and in terms of programming, editing and customizing the control functions.

SUMMARY OF THE INVENTION

The universal programmability of remote controls and other programmable or software-upgradeable CE apparatus is a valuable asset. It is an incentive for third parties to offer value-added features to the equipment's expandable functionality. In order to facilitate this, the inventors propose, among other things, to use a mark-up language format, preferably an XML (Extensible Markup Language) data format, in a service for supplying IR or RF commands for being installed on a remote control. The data can be supplied via a data network such as the Internet, or on a carrier such as a memory card. This data represents a control code to be installed on the remote that, when activated, determines the relevant IR or RF command. The data can be stored locally at the remote. An XML application, such as an XSL stylesheet, at the receiving end, operates on the data under control of instructions in the stylesheet. This application is used, for example, for control of generating the proper IR or RF commands based on the received data and for generating a GUI as an, e.g., HTML page on a suitable display.

If necessary, the data is converted to a proprietary format local to the remote before getting installed. An advantage of the invention resides in the fact that an open standard, such as XML/XSL for defining the behavior and appearance of a

2

The invention relates specifically to a method of providing, in a mark-up language format, preferably XML, data representative of a control code for installation on a control device. Preferably, the data is provided via a data network, e.g., the Internet. The user is enabled to specify to a server on the network an apparatus for being controlled by the control device. The server then identifies a corresponding control code for being provided as the data in the mark-up language format. The method of the invention can comprise providing a GUI element for use on the control device, the GUI element being supplied as further data in the mark-up language format. The GUI element can comprise a graphical representation of another remote control device. This latter feature is especially interesting if the universal programmable remote is to become the user's main remote for his/her CE equipment. It is assumed that the universal remote has a touch screen GUI. All relevant control codes of the separate remotes for individual pieces of equipment are now programmed in the universal remote using the scenario briefly discussed above and in more detail below. Assume that the universal remote, such as the PRONTO™ can reserve one or more graphical control panels per piece of equipment. That is, the control functionalities per piece of equipment are clustered. The invention now shapes the graphical representation of these panels as an image of the remote dedicated to that piece of equipment. That is, the universal remote displays an image of the dedicated remote with the control functionalities represented as soft keys where the dedicated remote provides hard keys. This enables quick recognition by the user and also allows the user to effortlessly switch between manipulating the universal remote and the dedicated remote. This feature can also be provided independent of the XML invention.

Accordingly, the inventors propose to have a server provide data to an end-user, preferably in XML format, for programming, setting up and control of local CE equipment. Using XML, the content/service provider does not need to support all possible target devices. Accordingly, the data can be supplied and put together without having to consider the particularities of the destination platform on which the data is to be installed. An XML application (here: a parser) extracts the relevant items and attributes from the XML data received and transforms them to further data that can be installed and/or processed locally at the destination platform.

The XML/XSL concept is widely known. It is being used to present data on browsers and to direct browser activity. XML enables to have common data formats in order to share the format as well as the data. XML separates the information to be rendered from the rendering instructions. XML describes data using tags. Custom tags enable the definition, transmission, validation, and interpretation of data between applications. The tags specify what each piece of data represents. That is, the tags comprise the semantic information about the data. As a result, an electronic document in XML can be rendered in different manners. This concept is now applied in the invention to IR or RF remote controls. By being able to have control codes delivered to the end user as XML files, e.g., via the Internet, the user can process the files locally through appropriate applications on his/her PC or set-top box, or even on the remote itself, in order to set up the remote for control of CE equipment with the codes thus received.

More specifically, the IR or RF codes are described using XML. A number of parameters can be defined using XML tags, for example, carrier frequency, duty cycle, protocol type (FSK, biphasic, PWM, etc.), repetition time, on/off times of the signal, bit pattern of the command code, semantic mean-

etc. Preferably, these data fields are not all used within the remote: only the information required to transmit the actual IR or RF code needs to be stored. On a server, the brand name and device type can be used to run database queries, e.g., in order to allow selective downloads. For example, a set top box (STB) offers a dedicated service at its portal to download IR codes upon the user having entered input descriptive of the device to be controlled, its brand and type number.

As to the remote's GUI, currently the PRONTO™ uses a proprietary format as a configuration file. This file contains information about the types and names of devices supported by the PRONTO™. Per device, the GUI is organized as a collection of pages. The GUI displays one page at the time. A specific page comprises one or more panels and soft keys or buttons. A button is graphically represented by, e.g., a labeled icon. A particular panel may comprise one or more panels and/or one or more further buttons. With each button and panel are associated certain properties, such as positions on the remote's display when rendered, labels, bitmaps, a function and its arguments (e.g., send+IR code, beep+sound samples, jump+device and page number, delay+time, etc). In the invention, all this information is preferably described using the XML format. This, in combination with XSL, is used to define the GUI of a touch screen remote.

The invention enables the following scenario. The user notifies a dedicated server on the Internet of the purchase of the type, brand, serial number, etc., of a new CE apparatus for which he/she would like add the codes to the universal programmable remote. The remote has a touch screen and display monitor. The new apparatus has come with a simple proprietary remote. The server now downloads to the user's home network the control codes in XML format, plus a tagged file for creating a bitmap of the proprietary remote on the universal remote's display monitor. When the control codes and data for the bitmap generation have been installed, the user can control the new apparatus through the virtual remote displayed on the universal remote's touch screen display monitor. Touching the screen in the location of a graphic representation of a proprietary remote's button causes the universal remote to send the corresponding IR or RF code. Note that the XML tags determine the rendering of the graphics image depending on the XSL stylesheet on the receiving platform.

A further interesting aspect of the invention is the following. The number of information appliances with Internet connectivity, e.g., enhanced TV's, set-top boxes (STB's), PDA's, smart phones, etc., and with different capabilities, e.g., processing power, memory capacity, display screen real estate, screen resolution, network connection, is rapidly growing. XML and XSL provide the basic building blocks of a framework for generic and flexible information exchange over the Internet that can be tailored to different machine conditions and user preferences. This framework is now applied in the invention to build an electronic program guide (EPG) or electronic content guide (ECG) that adapts the representation of, e.g., TV programs and other content information stored in an XML format to different information appliances and user profiles. Dynamically modified XSL stylesheets model the capabilities of the information appliance and the user preferences. The stylesheets translate and format the program information represented in XML in a Web presentation language such as HTML. In this manner, the semantics of the program information is separated from its presentation language syntax. The EPG or ECG is downloaded from the user's home network onto a programmable remote that has a touch screen

control codes in XML in order to enable a user to control, e.g., selection of, and playing-out or recording a specific one of the programs in the EPG/ECG rendered on the remote's display.

BRIEF DESCRIPTION OF THE DRAWING

The invention is explained in further detail, by way of example, and with reference to the accompanying drawing, wherein FIG. 1 is a block diagram of a system of the invention.

DETAILED EMBODIMENTS

XML is emerging as the universal format for structured documents and data on the Web. XML makes it relatively straightforward to define new document types, to author and manage documents and to transmit and share the documents across the Internet. XSL is used for defining stylesheets, and provides a language for translating XML documents and an XML vocabulary. XSL specifies the formatting of semantics. Information in XML format on the Web can be transformed in a presentation format such as HTML, WML or SMIL with XSL stylesheets. This separation of semantics and presentation makes possible platform customization and user personalization of Web content. In an XSL transformation, an XSL processor or application reads an XML document and an XSL style sheet. Based on the instructions in the XSL style sheet, the XSL processor or application supplies a new XML, HTML or otherwise formatted document. The invention now uses this concept in a system or a service, wherein control codes for use on, e.g., a remote control device are being supplied in an open standard format, such as XML.

The invention covers both the usage of XML for IR or RF codes and for the GUI. The codes can be described using a number of parameters defined by XML tags. Examples have been mentioned above: carrier frequency, duty cycle, protocol type (FSK, biphasic, PWM, etc.), repetition time, on/off times of the signal, bit pattern of the command code, meaning of the code, type and brand of the device for which it is intended (CD, VCR, TV, etc.), the name of the specific control protocol, etc. Some of these data fields are used to enable to run a query on a server. Only that data required to have the remote send the particular control code is stored at the remote itself, or at an intermediate device such as the user's PC or set-top box. On the server, the brand name and device type is used to query the control code database to allow selective downloads.

FIG. 1 is a block diagram with main components of an information processing system 100 in the invention. System 100 comprises a server 102 connected via the Internet 104 to an appliance 106, e.g., a STB or a PC, at the user's home. The user has a universal programmable remote control device 108 with a touch screen UI 110. Device 108 has a transmitter 112 for sending an IR-control code or an RF-control code to electronics equipment (not shown), such as TVs, VCRs, CD players, STB's, DVD players, audio pre-amplifiers and tuners, etc., on the home network. Remote control device 108 has an input 114, e.g., a serial or parallel port or an IR sensor or transceiver, for communicating with appliance 106.

Server 102 has a database 116 with an inventory of IR and RF control codes for commercially available CE equipment of various brands and types. The service provider updates database 116 when new appliances are becoming available on the market. The codes are formatted as XML documents. That is, the relevant parameters of a particular control code or

code pertains, for its type number, for the IR or RF carrier frequency, for the duty cycle, the protocol type, for the repetition time, for the on/off times of the signal, etc. The brand name and device type tags are used to run database queries on server 102, e.g., in order to allow selective downloads.

The user requests via appliance 106 a code set from server 102 for control of the apparatus, type, brand, serial no., etc., as specified by the user and to be controlled via remote 108. This is achieved, e.g., by having the user fill out an electronic template at the service's web site and returning the template's information to server 102. Server 102 runs a query and, assuming that there is a match, supplies the associated set of codes via Internet 104 to appliance 106 as an XML document. Appliance 106 has an XML application 118 that extracts the data based on the relevant tags and interprets the data according to the semantics of the tags in order to generate the control codes and/or the GUI panels for remote 108. The GUI panel is preferably, but not necessarily, an HTML page. The control codes and/or GUI panels are then supplied to remote 108 via input 114 for being installed. For example, remote 108 is set into a programming mode for receiving the code at input 114 and for storing the code in a memory 120, e.g., a flash memory, under control of a processor 122. If UI 110 has a specific icon reserved for this control option, the user can instruct remote 108 to cause a driver 124 to control transmitter 112 for sending the IR or RF code.

As to the rendering of the graphical representation of the GUI at remote 108, the XML data matching the user's query at server 102 can be converted to the presentation data (WML, HTML, possibly CCF) at server 102 itself, using an XSL stylesheet. However, in this case server 102 needs to have information about remote 108 as to, e.g., its specific screen size, resolution and supported image format, so as to determine the correct XSL stylesheet to allow the data to be rendered for this specific remote. Alternatively, in case remote 108 receives its codes from server 102 via appliance 106, here an STB, part of the functionality to generate the GUI can be moved to appliance 106. Then, server 102 has only XML data but no stylesheets. This means that the service provider does not need to be aware of the target client device, here remote 108. Appliance 102 accesses server 102 to obtain the control code data. Appliance 102 can easily obtain the information about the target device, here remote 108, and its manufacturer or distributor can provide the proper XSL stylesheet and software required to generate the target format (WML, HTML, CCF). In yet another configuration, the XSL information and the XML/XSL combination is handled on the remote 108 itself, appliance 106 then merely being a conduit between server 102 and remote 108, wherein remote 108 accommodates the stylesheet information itself.

Note that conversion from an XML description into a dedicated format supported by remote control 108 can also be applied to the IR or RF control codes themselves. Again the conversion can be performed at server 102, at appliance 106 or at remote 108 itself.

The invention could also be implemented using a tagging or mark-up language other than XML implement the invention, and other style-sheets than XSL.

The following patent documents are incorporated herein by reference, among other things to provide a context for the current invention:

U.S. Ser. No. 09/434,155 filed Nov. 4, 1999 for Martin Freeman and Bonghan Cho for REMOTE CONTROL DEVICE WITH LOCATION DEPENDENT INTER-FACE. This document relates to a programmable remote

the unit. The unit comprises a memory to store the retrieved control configuration; a display for display of icons representing the configuration; and a touch screen for entering a selection based on the icons displayed. The storage device is a component of a CE apparatus. By storing or backing-up the control configuration for a specific apparatus in the apparatus itself, the remote is made truly universally programmable.

U.S. serial 09/427,821 filed Oct. 27, 1999 for Joost Kemink and Richard Sagar for PDA HAS WIRELESS MODEM FOR REMOTE CONTROL VIA THE INTERNET. This document discloses a PDA combined with a wireless modem to enable remote control of CE equipment via the Internet and a local home server.

U.S. Ser. No. 09/271,200 filed Mar. 17, 1999 for Jan van Ee for FULLY FUNCTIONAL REMOTE CONTROL EDITOR AND EMULATOR. This document relates to a universal programmable remote control device. The device has programmability functions that enable the end-user to customize the device through editing or programming the device's control functionalities. The programming can be achieved via a PC. The control configuration created via an editor on the PC can be downloaded into the device. The PC has emulator software to test the configuration before downloading. The emulator software and the remote's control software are made identical as a consequence of a software layer that abstracts from the remote's hardware. The emulator for the end-user is thus obtained as an almost free byproduct of the software development phase at the manufacturer.

U.S. Ser. No. 09/160,490 filed Sep. 25, 1998 for Adrian Turner et al., for CUSTOMIZED UPGRADING OF INTERNET-ENABLED DEVICES BASED ON USER-PROFILE. This document relates to a server system that maintains a user profile of a particular end-user of consumer electronics network-enabled equipment and also has a data base of new technical features for this type of equipment. If there is a match between the user-profile and a new technical feature, and the user indicates to receive information about updates or sales offers, the user gets notified via the network of the option to obtain the feature.

U.S. Ser. No. 09/568,932 filed May 11, 2000 for Eugene Shteyn and Ruud Roth for ELECTRONIC CONTENT GUIDE RENDERS CONTENT RESOURCES TRANSPARENT. This document relates to a data management system on a home network. The system collects data that is descriptive of content information available at various resources on the network. The data is combined in a single menu to enable the user to select from the content, regardless of the resource. Known EPG's still focus on the device or apparatus that provides the content information, rather than on the content information itself regardless of its resource and/or regardless of its time of availability, e.g., broadcast. That is, the known guides are device-centric and broadcast-centric rather than content-centric, whereas the user is typically more interested in the "what" of the content information than in the "wherefrom". Recording devices with personalization features in a digital context, such as the HDD-based Personal TV Receiver from Tivo, are changing the perspective of selecting content information. However, it is no longer relevant to the consumer when what program is being broadcasted by a broadcast station or supplied by another service provider, such as in a video-

Explore Litigation Insights

Docket Alarm provides insights to develop a more informed litigation strategy and the peace of mind of knowing you're on top of things.

Real-Time Litigation Alerts



Keep your litigation team up-to-date with **real-time alerts** and advanced team management tools built for the enterprise, all while greatly reducing PACER spend.

Our comprehensive service means we can handle Federal, State, and Administrative courts across the country.

Advanced Docket Research



With over 230 million records, Docket Alarm's cloud-native docket research platform finds what other services can't. Coverage includes Federal, State, plus PTAB, TTAB, ITC and NLRB decisions, all in one place.

Identify arguments that have been successful in the past with full text, pinpoint searching. Link to case law cited within any court document via Fastcase.

Analytics At Your Fingertips



Learn what happened the last time a particular judge, opposing counsel or company faced cases similar to yours.

Advanced out-of-the-box PTAB and TTAB analytics are always at your fingertips.

API

Docket Alarm offers a powerful API (application programming interface) to developers that want to integrate case filings into their apps.

LAW FIRMS

Build custom dashboards for your attorneys and clients with live data direct from the court.

Automate many repetitive legal tasks like conflict checks, document management, and marketing.

FINANCIAL INSTITUTIONS

Litigation and bankruptcy checks for companies and debtors.

E-DISCOVERY AND LEGAL VENDORS

Sync your system to PACER to automate legal marketing.