



US 20040080428A1

(19) **United States**

(12) **Patent Application Publication** (10) **Pub. No.: US 2004/0080428 A1**

Rye et al.

(43) **Pub. Date: Apr. 29, 2004**

(54) **RF AUDIOVISUAL COMPONENT REMOTE CONTROL SYSTEM**

(22) Filed: **Oct. 25, 2002**

(75) Inventors: **David John Rye, Kent, WA (US); Lesley Alan Leech, Kowloon (HK)**

Publication Classification

(51) **Int. Cl.7** **G05B 19/02; G08C 19/00**

(52) **U.S. Cl.** **340/825.69; 340/825.24**

Correspondence Address:

**Marvin N. Gordon
Suite 2015
630 Fifth Avenue
New York, NY 10111 (US)**

(57) **ABSTRACT**

A handheld remote control unit transmits binary coded rf address and control signals to an addressable transceiver where those signals are detected, decoded and processed to derive binary coded control signals that are coded in accordance with the brands or manufacturers of the audiovisual components that are to be controlled along with the function that is to be thus controlled for the addressed components.

(73) Assignee: **X10 Wireless Technology, Inc.**

(21) Appl. No.: **10/279,614**

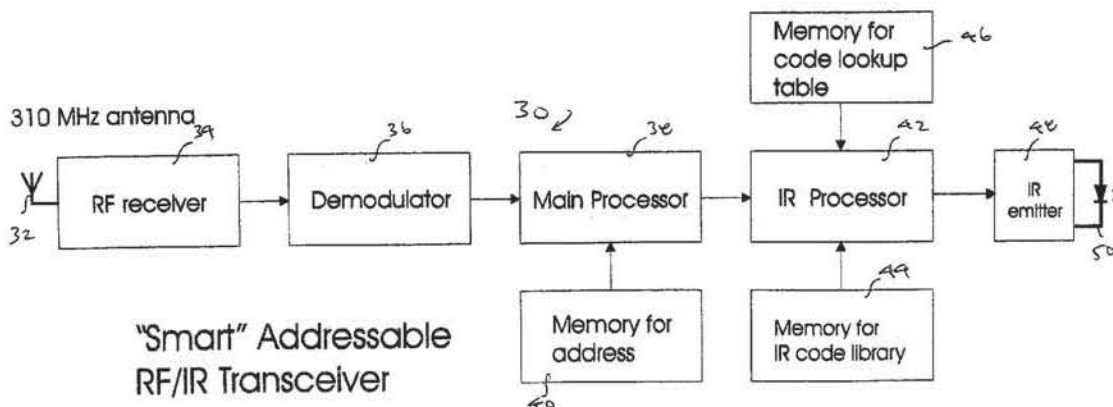

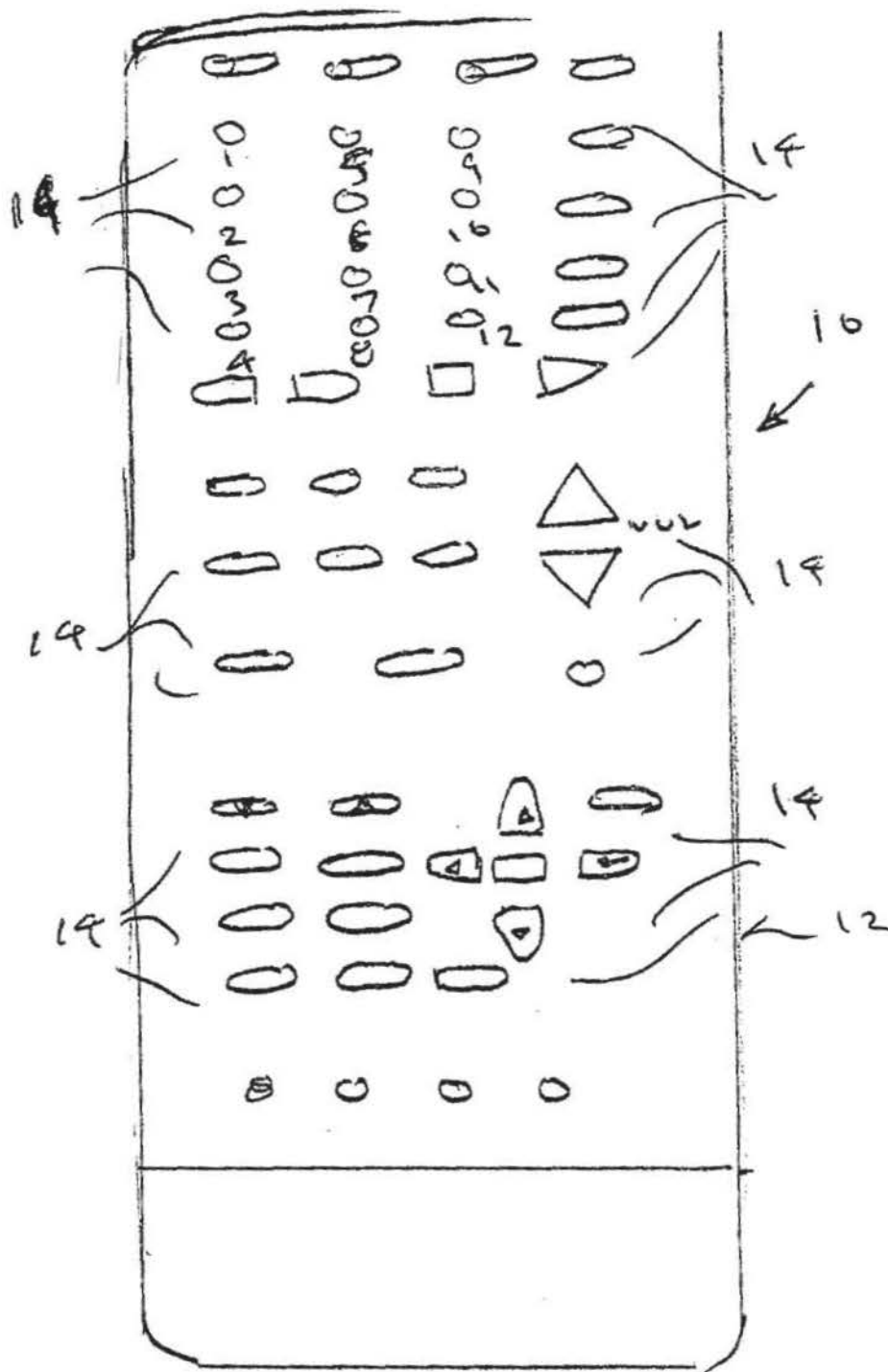
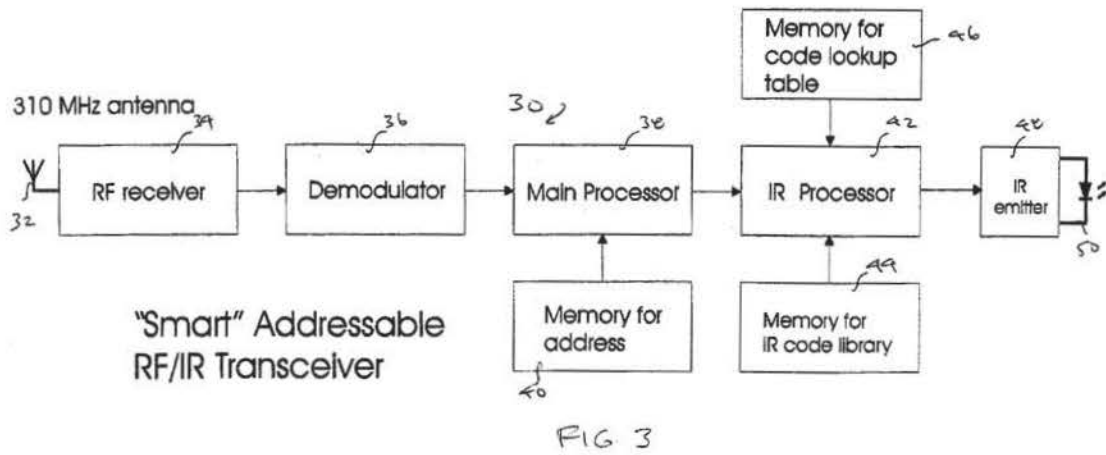
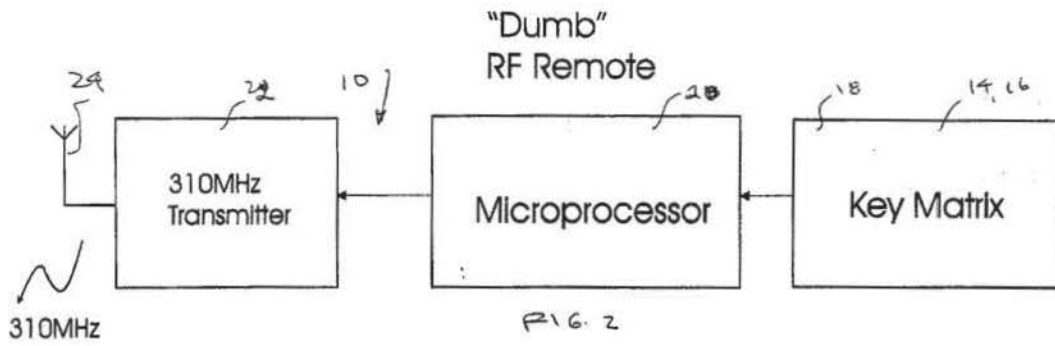

FIG. 1



RF AUDIOVISUAL COMPONENT REMOTE CONTROL SYSTEM

BACKGROUND OF THE INVENTION

[0001] I. Field of the Invention

[0002] The present invention relates to the remote control of audiovisual components.

[0003] II. Description of the Prior Art

[0004] The presence of a home entertainment system or center is rapidly becoming common in American homes as the quality of the several audio and video components used in such systems has increased while their prices have declined to make them more affordable to many households. A typical home entertainment center includes a television receiver, a DVD player, a cable box or converter, a control amplifier and tuner and a videocassette recorder (VCR). The operation of these components is commonly controlled by the use of one or more handheld remote control units, which, depending on the button pushed by the user, transmits binary-coded infra-red signals which are received and decoded by the associated audio or visual component to, for example, turn it "on" or "off", change the channel, or open or close the disc holder in the case of a DVD player.

[0005] In many, if not most, of these home entertainment systems, the individual components are manufactured by different manufacturers. For example, a home entertainment center may include a TV receiver made by Sony, a DVD player made by Toshiba and a control amplifier made by Denon, each having a unique binary control code that controls its operation. To operate these components by remote control, the user must either use a different brand-specific remote control unit for each manufacturer's component, which is sold with that component, or purchase and program a so-called "universal" remote control that can be pre-programmed by the user to store the operating binary control codes associated with the several brands of the audiovisual components. These universal remote control units emit infrared signals that are coded in accordance with the stored codes specific to the several brands of audiovisual components that are to be controlled, and are thus able to replace the multiple brand-specific remote control units with a single unit.

[0006] Most currently available handheld remote control units are provided with a plurality of pushbutton switches that allow the user to enter control signals manually. Encoding circuitry in the unit, in response to the actuation of the particular control switch, produces binary coded electrical signals that uniquely identify the particular manually entered command. An infrared light emitter in the unit is driven to emit infrared light signals binary coded in correspondence to the encoded commands and to the brand of the audiovisual component to which the coded control signals are directed.

[0007] The audiovisual component whose operation is to be remotely controlled is typically provided with an infrared detector that receives the coded infrared control or command signal from the hand-held remote control, and converts the received coded command signal to an electrical signal to which the remotely controlled audiovisual component responds by executing the corresponding command, e.g., increase volume or change channel.

[0008] In recently issued U.S. Pat. No. 6,397,288, assigned to the assignee of the present application, I disclose a "virtual" remote control unit whose image is displayed on a PC monitor. The user by touching or clicking onto the appropriate areas of the image of the remote control unit selects a desired control function, e.g., TV "off" or "one". An interface connected to an I/O port of the PC transmits a corresponding binary coded RF signal to a receiver at which the transmitted, coded signal is decoded and converted to a correspondingly coded infrared signal.

[0009] The control or command codes for the various brands of audiovisual components in the user's system are stored in a code library included in the receiver. Thus, for example, when the PC interface transmits an RF signal corresponding to "VCR Play" the receiver looks up in the receiver code library the code for the user's brand of VCR and then transmits an infrared coded signal for "Play" for that brand of VCR. This system, although reliable and effective, does, however, require the use of a PC and accompanying additional software as well as the interface, which adds to the cost and complexity of the system.

[0010] U.S. Pat. No. 4,809,359 is of interest in its disclosure of a system for extending the effective operational range of an infrared remote control system. The disclosed system includes a first repeater that receives binary coded infrared commands from a remote control unit. The first repeater generates a corresponding RF signal representative of the received infrared signals. Those coded RF signals are received by a second repeater, which, in response, generates and transmits a corresponding coded infrared signal to the controlled component. U.S. Pat. No. 5,383,044 is of interest in its disclosure of an RF remote control system in which the infrared commands are modulated onto an RF carrier that is received at a receiver in which the commands are detected and the RF signal is converted to a corresponding coded infrared signal that is transmitted to the audiovisual component.

[0011] The remote control system described in U.S. Pat. No. 5,383,044 requires the use of a special RF remote and does not work with the user's existing infrared remote control. A further disadvantage of both of these prior patented remote control systems is that if the user owns more than one audiovisual component of the same brand, the user cannot use multiple receivers since the remote control would incorrectly and accidentally control the operation of both of these audiovisual components. For example, most television receivers respond to a "toggle function" for ON-OFF, that is, the same command code is transmitted from the remote control to turn it "on" or "off". Thus, for example, if the user has two identical television receivers in different rooms and one of them is "on" and the other is "off", the use of either of these patented remote controls to turn "on" a television that was "off" would improperly also turn "on" the other television that was "off".

SUMMARY OF THE INVENTION

[0012] It is an object of the present invention to provide a remote control system for use in controlling the operation of a multi-brand audiovisual component system that is cost-effective and reliable.

[0013] It is a more general object of the present invention to provide a remote control system of the type described that avoids the drawbacks and disadvantages of the prior art remote control systems.

[0014] It is another object of the present invention to provide a remote control system of the type described, which can address a receiver and is thus able to individually control multiple audiovisual components of the same brand and model located in different rooms of the user's home.

[0015] In accordance with the present invention, an "actual" remote control, rather than the "virtual" remote control disclosed in my U.S. Pat. No. 6,397,288, transmits coded RF binary signals to an addressable transceiver where the signals are decoded to derive binary coded control signals and processed to code those signals in accordance with the manufacturer or brand of the audiovisual component that is to be remotely controlled by the coded control signals. The remote control system of this invention thus represents an improvement over that disclosed in U.S. Pat. No. 6,397,288 since it does not require the use of a PC and the software required to create the "virta" remote.

[0016] To this end, the addressable transceiver includes a memory for IR code library that stores the remote control codes for the commercial brands of audiovisual components, and a lookup table that stores the remote control codes for all the audiovisual components in the user's home. The library and lookup table are connected to a microprocessor in which the brand or product codes are combined with the received binary coded control signals. The thus processed and modified coded control signals are converted to corresponding coded infrared control signals which are transmitted to the selected audiovisual component.

BRIEF DESCRIPTION OF THE DRAWINGS

[0017] To the accomplishment of the above and such further objects as may hereinafter appear, the present invention is directed to an RF remote control system substantially as defined in the appended claims and as described in the following detailed specification of a preferred embodiment thereof as considered with the accompanying drawings in which:

[0018] FIG. 1 is an elevation of a hand-held remote control unit which may be used in the remote control system of the invention;

[0019] FIG. 2 is a schematic block diagram of the remote control unit of FIG. 1; and

[0020] FIG. 3 is a schematic block diagram of a transceiver that can be used in the remote control system of the invention.

DETAILED DESCRIPTION OF THE PREFERRED EMBODIMENT

[0021] Referring to the drawings, there is shown in FIG. 1 an example of a hand-held remote control unit generally designated 10 that may be used in the remote control system of the present invention. As therein shown, unit 10 includes a housing or case 12 which contains the integrated circuits and other components of the unit, as is conventional. As is also conventional, unit 10 includes an array of pushbuttons 14, which, when pressed down by the user, actuate the

internal circuitry contained in unit 10 to produce the appropriate binary coded commands or control signals that are transmitted from unit 10 to control selectively the audiovisual component, for example, to turn a DVD player "on" or raise the volume.

[0022] As shown in the schematic diagram of the remote control unit 10 depicted in FIG. 2, the unit 10 includes a key matrix 18, which, in a known manner, in response to the user operation of one of the pushbuttons 14 produces a memory address signal that is applied to a microprocessor 20 in which is stored a plurality of binary control codes corresponding to the various functions of the audiovisual components that are to be controlled by the operation of unit 10. The binary control codes stored in the microprocessor 20 are generic codes in that they are not specific for any particular brand or model of audiovisual product. The binary coded signal generated by the microprocessor 20, in response to the user operation of one of the pushbuttons 14, is applied to a modulator-transmitter 22 in which the microprocessor output binary coded control signal is modulated onto a radio-frequency carrier of e.g., 310 MHz. That radio-frequency binary coded signal is transmitted by an antenna 24 included in unit 10 to an addressable transceiver generally designated 30, illustrated schematically in FIG. 3.

[0023] As therein shown, transceiver 30 receives the binary coded address and function control rf signal from the remote control unit 10. In overview, those signals are converted in transceiver 30 to corresponding binary coded infrared (IR) signals, which are then transmitted over-the-air to the selected audiovisual component to control its operation. To this end, as shown in FIG. 3, transceiver 30 includes an rf antenna 32 whose output is connected to the input of an rf receiver 34. The output of receiver 34 is coupled to an input of a demodulator 36, the output of which is applied to an input of a main microprocessor 38. An address memory 40 is connected to another input of microprocessor 38. Memory 40 stores the addresses of the transceiver 30 (?) as well as the addresses of the various audiovisual components whose operation is to be remotely controlled in response to the binary coded rf signals received at transceiver 30 from the remote control unit 10. The transceiver's main processor 38 looks up its address in memory 40 and compares it to the address code received from unit 10 to check that the received command code is intended for this particular transceiver.

[0024] If an address match is detected in microprocessor 38 its output is applied to one input of an infrared (IR) processor 42, which receives at another input the contents of a universal IR code library memory 44. Memory 44 contains the remote control codes for all brands, e.g., Sony and Zenith, and models of commercially available audiovisual components. For example, if the audiovisual component is a television receiver identified on the user's remote control unit as TV 1 is a Sony and a second television receiver in the home identified as TV 2 is a Zenith, memory 44 would store the Sony remote control code for TV 1 and the Zenith remote control code for TV 2. (DAVE, WHERE AND HOW ARE TV1 AND TV 2 IDENTIFIED HERE?) IR microprocessor 42 also receives an input from a memory 46 for the code lookup table. The remote control codes stored in memory 46, which are derived from code library memory 44 through the microprocessor 42, may be periodically supplemented or otherwise modified by the user when a new audiovisual component is acquired or a currently owned component is

Explore Litigation Insights

Docket Alarm provides insights to develop a more informed litigation strategy and the peace of mind of knowing you're on top of things.

Real-Time Litigation Alerts



Keep your litigation team up-to-date with **real-time alerts** and advanced team management tools built for the enterprise, all while greatly reducing PACER spend.

Our comprehensive service means we can handle Federal, State, and Administrative courts across the country.

Advanced Docket Research



With over 230 million records, Docket Alarm's cloud-native docket research platform finds what other services can't. Coverage includes Federal, State, plus PTAB, TTAB, ITC and NLRB decisions, all in one place.

Identify arguments that have been successful in the past with full text, pinpoint searching. Link to case law cited within any court document via Fastcase.

Analytics At Your Fingertips



Learn what happened the last time a particular judge, opposing counsel or company faced cases similar to yours.

Advanced out-of-the-box PTAB and TTAB analytics are always at your fingertips.

API

Docket Alarm offers a powerful API (application programming interface) to developers that want to integrate case filings into their apps.

LAW FIRMS

Build custom dashboards for your attorneys and clients with live data direct from the court.

Automate many repetitive legal tasks like conflict checks, document management, and marketing.

FINANCIAL INSTITUTIONS

Litigation and bankruptcy checks for companies and debtors.

E-DISCOVERY AND LEGAL VENDORS

Sync your system to PACER to automate legal marketing.