



(12) **United States Patent**
Fallon

(10) **Patent No.:** **US 6,195,024 B1**
(45) **Date of Patent:** **Feb. 27, 2001**

(54) **CONTENT INDEPENDENT DATA
COMPRESSION METHOD AND SYSTEM**

(75) Inventor: **James J. Fallon**, Bronxville, NY (US)

(73) Assignee: **Realtime Data, LLC**, New York, NY (US)

(*) Notice: Subject to any disclaimer, the term of this patent is extended or adjusted under 35 U.S.C. 154(b) by 0 days.

(21) Appl. No.: **09/210,491**

(22) Filed: **Dec. 11, 1998**

(51) Int. Cl.⁷ **H03M 7/34**; H03M 7/00

(52) U.S. Cl. **341/51**; 341/79

(58) **Field of Search** 341/51, 79, 67;
709/231, 219, 236, 250; 358/1.1; 712/32;
711/208

(56) **References Cited**

U.S. PATENT DOCUMENTS

4,872,009	10/1989	Tsukiyama et al. .	
4,929,946	5/1990	O'Brien et al. .	
5,045,852	9/1991	Mitchell et al. .	
5,097,261	3/1992	Langdon, Jr. et al. .	
5,175,543	* 12/1992	Lantz	341/51

(List continued on next page.)

Primary Examiner—Patrick Wamsley

34 Claims, 16 Drawing Sheets

(74) *Attorney, Agent, or Firm*—Frank V. DeRosa; F. Chau & Associates, LLP

(57) **ABSTRACT**

Systems and methods for providing content independent lossless data compression and decompression. A data compression system includes a plurality of encoders that are configured to simultaneously or sequentially compress data independent of the data content. The results of the various encoders are compared to determine if compression is achieved and to determine which encoder yields the highest lossless compression ratio. The encoded data with the highest lossless compression ratio is then selected for subsequent data processing, storage, or transmittal. A compression identification descriptor may be appended to the encoded data with the highest compression ratio to enable subsequent decompression and data interpretation. Furthermore, a timer may be added to measure the time elapsed during the encoding process against an a priori-specified time limit. When the time limit expires, only the data output from those encoders that have completed the encoding process are compared. The encoded data with the highest compression ratio is selected for data processing, storage, or transmittal. The imposed time limit ensures that the real-time or pseudo-real-time nature of the data encoding is preserved. Buffering the output from each encoder allows additional encoders to be sequentially applied to the output of the previous encoder, yielding a more optimal lossless data compression ratio.

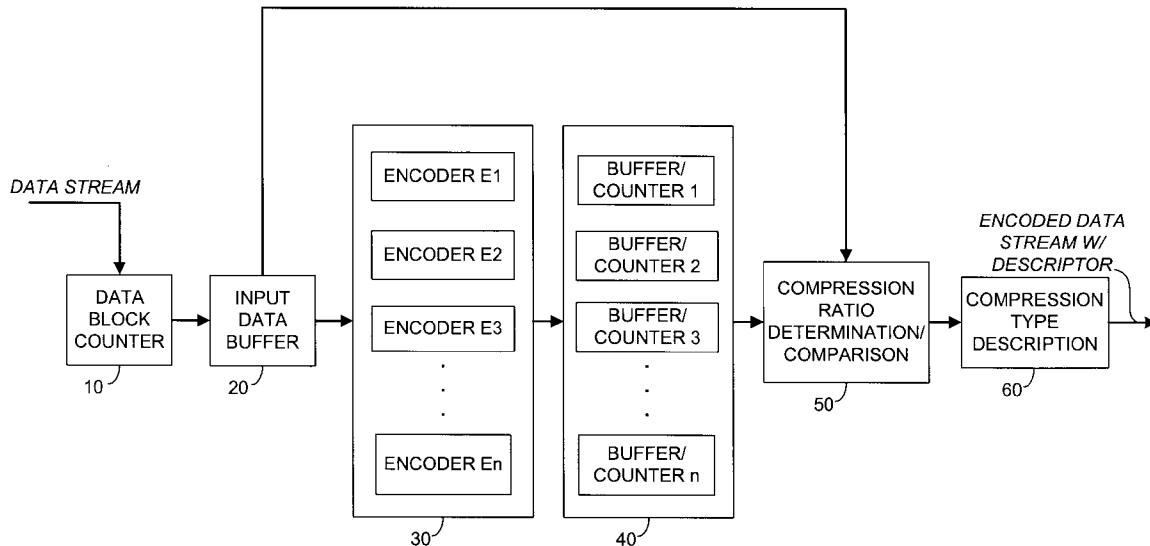

U.S. PATENT DOCUMENTS					
5,212,742	5/1993	Normile et al. .	5,717,393	2/1998	Nakano et al. .
5,231,492	7/1993	Dangi et al. .	5,717,394	2/1998	Schwartz et al. .
5,243,341	9/1993	Seroussi et al. .	5,729,228	3/1998	Franaszek et al. .
5,243,348	9/1993	Jackson .	5,748,904	5/1998	Huang et al. .
5,270,832	12/1993	Balkanski et al. .	5,771,340	6/1998	Nakazato et al. .
5,379,036	1/1995	Storer .	5,784,572	7/1998	Rostoker et al. .
5,381,145	1/1995	Allen et al. .	5,799,110	8/1998	Israelsen et al. .
5,394,534	2/1995	Kulakowski et al. .	5,805,932	9/1998	Kawashima et al. .
5,412,384 *	5/1995	Chang et al. 341/79	5,809,176	9/1998	Yajima .
5,461,679	10/1995	Normile et al. .	5,818,368	10/1998	Langley .
5,467,087	11/1995	Chu .	5,818,530	10/1998	Canfield et al. .
5,471,206	11/1995	Allen et al. .	5,819,215	10/1998	Dobson et al. .
5,479,587	12/1995	Campbell et al. .	5,825,424	10/1998	Canfield et al. .
5,486,826	1/1996	Remillard .	5,847,762	12/1998	Canfield et al. .
5,495,244	2/1996	Je-Chang et al. .	5,861,824	1/1999	Ryu et al. .
5,533,051	7/1996	James .	5,917,438	6/1999	Ando .
5,583,500	12/1996	Allen et al. .	5,964,842	10/1999	Packard .
5,627,534	5/1997	Craft .	5,991,515	11/1999	Fall et al. .
5,654,703	8/1997	Clark, II .	6,031,939	2/2000	Gilbert et al. .
5,668,737	9/1997	Iler .			

* cited by examiner

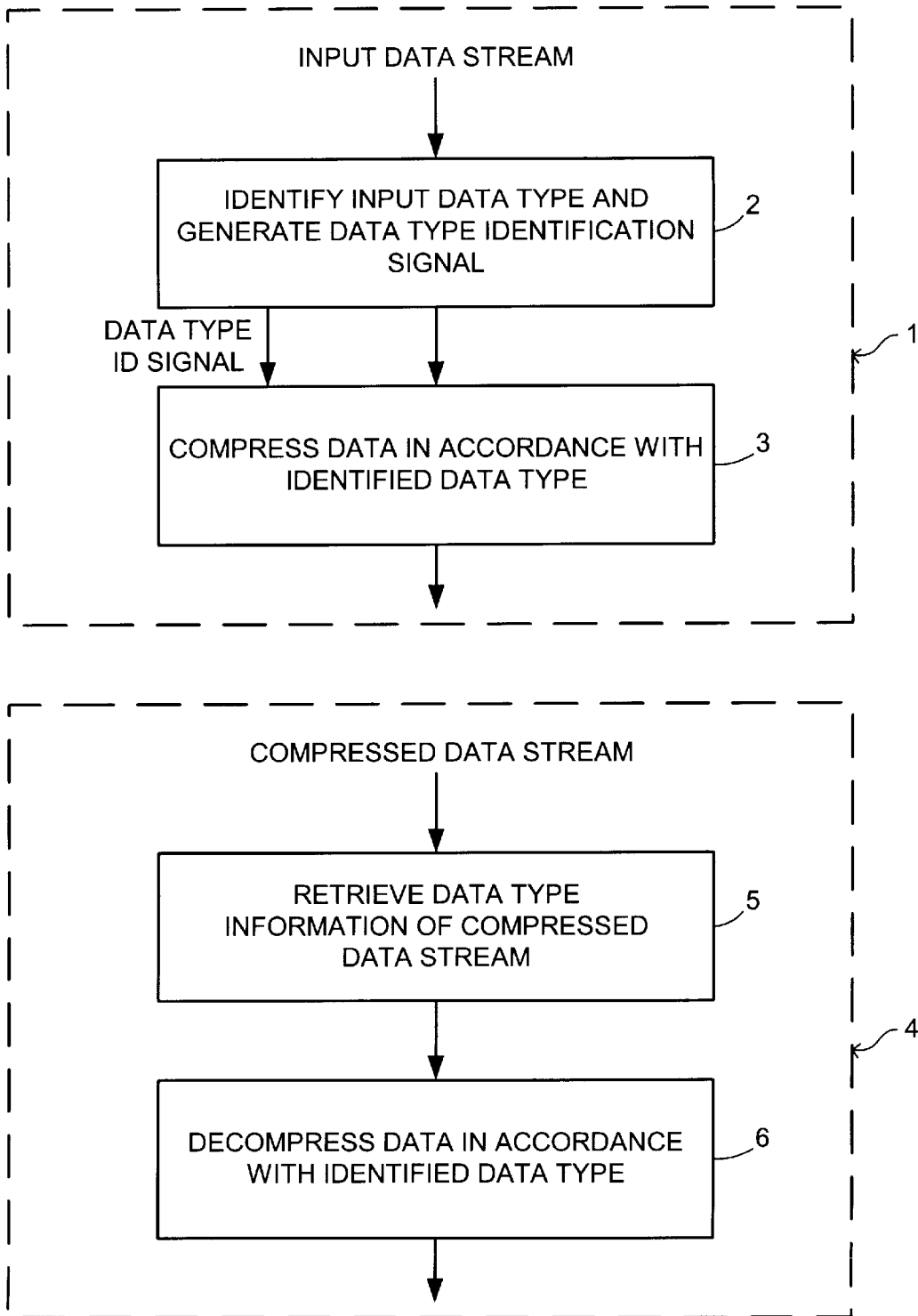

FIG. 1
PRIOR ART

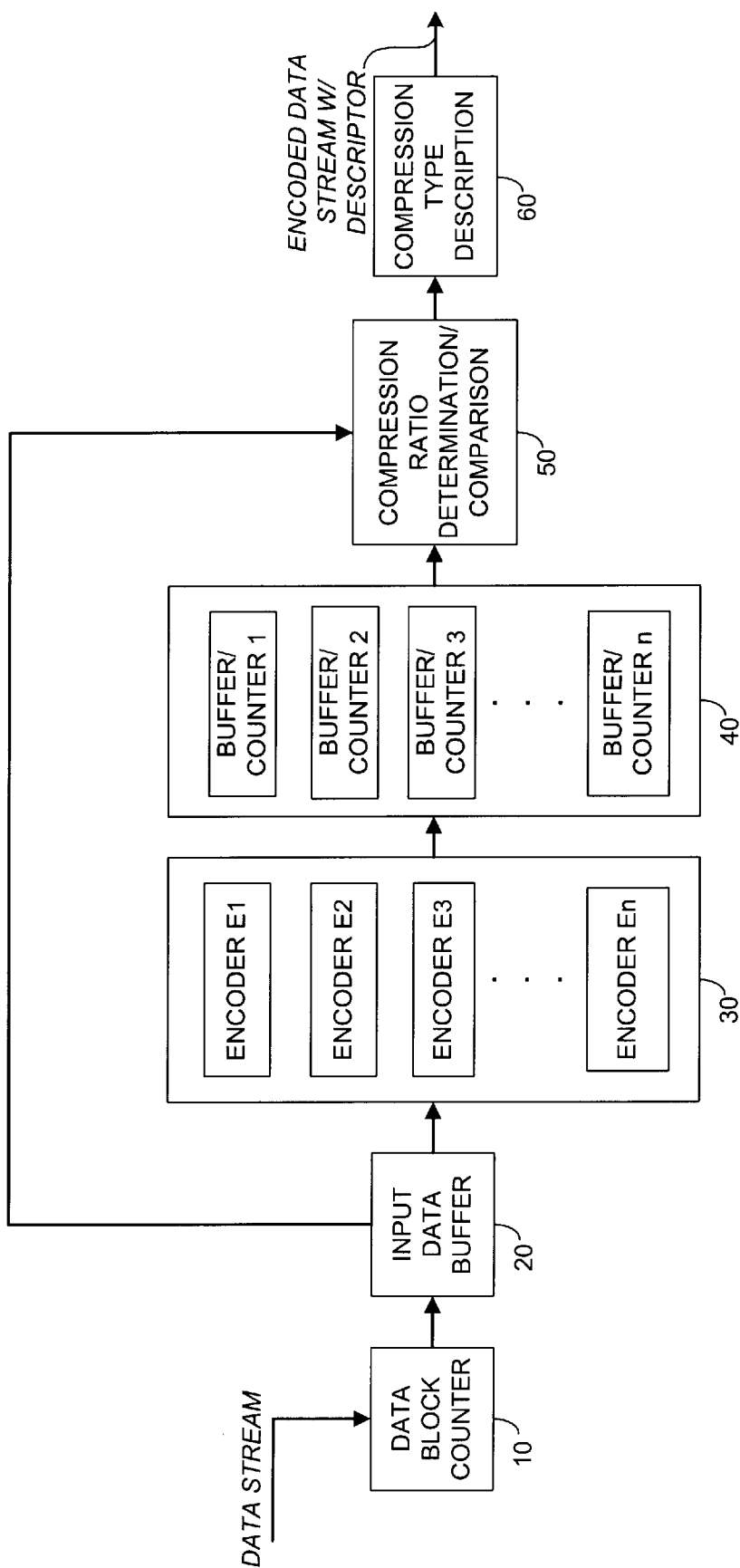

FIG. 2

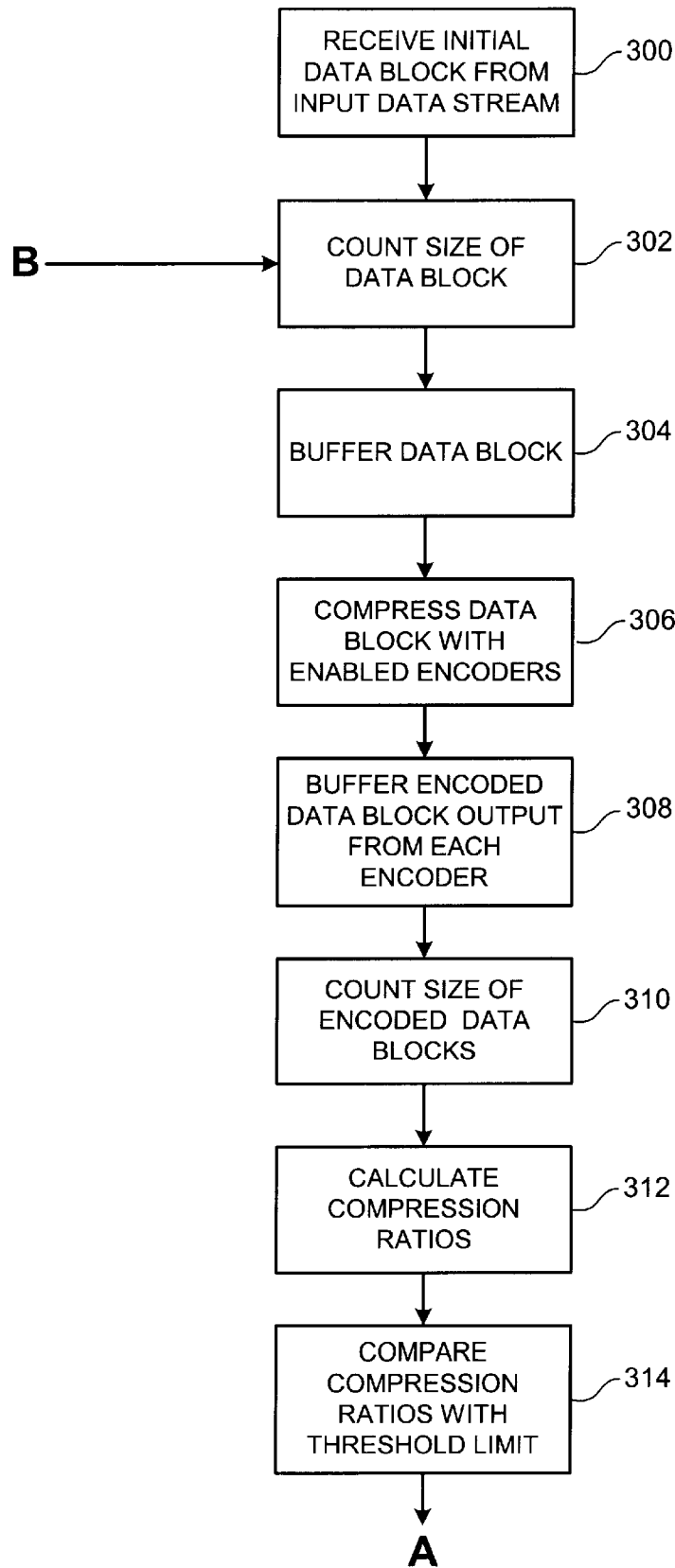

FIG. 3a

Explore Litigation Insights

Docket Alarm provides insights to develop a more informed litigation strategy and the peace of mind of knowing you're on top of things.

Real-Time Litigation Alerts



Keep your litigation team up-to-date with **real-time alerts** and advanced team management tools built for the enterprise, all while greatly reducing PACER spend.

Our comprehensive service means we can handle Federal, State, and Administrative courts across the country.

Advanced Docket Research



With over 230 million records, Docket Alarm's cloud-native docket research platform finds what other services can't. Coverage includes Federal, State, plus PTAB, TTAB, ITC and NLRB decisions, all in one place.

Identify arguments that have been successful in the past with full text, pinpoint searching. Link to case law cited within any court document via Fastcase.

Analytics At Your Fingertips



Learn what happened the last time a particular judge, opposing counsel or company faced cases similar to yours.

Advanced out-of-the-box PTAB and TTAB analytics are always at your fingertips.

API

Docket Alarm offers a powerful API (application programming interface) to developers that want to integrate case filings into their apps.

LAW FIRMS

Build custom dashboards for your attorneys and clients with live data direct from the court.

Automate many repetitive legal tasks like conflict checks, document management, and marketing.

FINANCIAL INSTITUTIONS

Litigation and bankruptcy checks for companies and debtors.

E-DISCOVERY AND LEGAL VENDORS

Sync your system to PACER to automate legal marketing.