

(12) **United States Patent**
Acampora

(10) **Patent No.:** **US 6,751,455 B1**
(45) **Date of Patent:** **Jun. 15, 2004**

(54) **POWER- AND BANDWIDTH-ADAPTIVE IN-HOME WIRELESS COMMUNICATIONS SYSTEM WITH POWER-GRID-POWERED AGENTS AND BATTERY-POWERED CLIENTS**

(75) Inventor: **Anthony Acampora**, La Jolla, CA (US)

(73) Assignee: **The Regents of the University of California**, Oakland, CA (US)

(*) Notice: Subject to any disclaimer, the term of this patent is extended or adjusted under 35 U.S.C. 154(b) by 510 days.

(21) Appl. No.: **09/663,068**

(22) Filed: **Sep. 15, 2000**

Related U.S. Application Data

(60) Provisional application No. 60/154,615, filed on Sep. 17, 1997.

(51) **Int. Cl.**⁷ **H04Q 7/20**; H04Q 7/24

(52) **U.S. Cl.** **455/414.1**; 455/41; 455/422.1; 455/448; 370/338

(58) **Field of Search** 455/41, 343, 122, 455/126, 522, 421, 422, 414, 567, 402, 502, 11.1, 446, 556, 566, 53.1, 448; 370/349, 351, 352, 338, 408, 350; 709/248, 203; 340/825.31, 825.34; 379/56, 102, 96, 60, 59; 343/853, 824, 893, 751; 700/12, 20, 275

(56) **References Cited**

U.S. PATENT DOCUMENTS

4,771,448	A	*	9/1988	Koohgoli et al.	455/450
5,361,985	A	*	11/1994	Rein et al.	236/49.3
5,564,070	A	*	10/1996	Want et al.	455/507
5,802,467	A	*	9/1998	Salazar et al.	455/420
5,999,094	A	*	12/1999	Nilssen	340/507
6,304,556	B1	*	10/2001	Haas	370/254
6,396,457	B1	*	5/2002	Gatherer et al.	343/853
6,542,754	B1	*	4/2003	Sayers et al.	455/502
2002/0027894	A1	*	3/2002	Arrakoski et al.	370/338
2002/0047774	A1	*	4/2002	Christensen et al.	340/3.54

FOREIGN PATENT DOCUMENTS

WO WO 99/17477 * 4/1999

OTHER PUBLICATIONS

HomeRF Specification HomeRF, Jul. 1, 2002, Revision 2.01.*

* cited by examiner

Primary Examiner—Dwayne Bost

Assistant Examiner—Kamran Afshar

(74) *Attorney, Agent, or Firm*—Fish & Richardson P.C.

(57) **ABSTRACT**

A radio link management system for a home or office substantially (i) an ad hoc network of agents wirelessly communicating among themselves, while (iii) clients wirelessly communicate with proximate agents. Control of the network may be centralized as network controller integrated with an agent, or may be distributed upon the network of agents. Some agent or agents, which may include an agent that is also the network controller, typically serves as a gateway device which connects to a worldwide communications network external to the home or office, normally by fiber or by wire.

Each agent is most commonly a small radio transceiver plus logic and power supply that mounts upon a wall and plugs directly into an AC power socket. Agents wirelessly communicate among themselves and with the controller—which may be centralized or distributed—in a bandwidth-efficient mode since prime power is not an issue. Each client, which is most commonly a battery-powered user device, wirelessly radio communicates with one or more proximately-located agents. Consistent with overall demand for the radio resource, parameters for radio communication are allocated ad hoc in a manner which is (a) client-dependent, and which (b) uses the least power from the battery-powered client. The agents establish an ad-hoc network among themselves, with routing among and between the agents being both multi-hop and “minimum hop” to conserve bandwidth. Accordingly both power and bandwidth are conserved, each as and where required and desired.

20 Claims, 1 Drawing Sheet

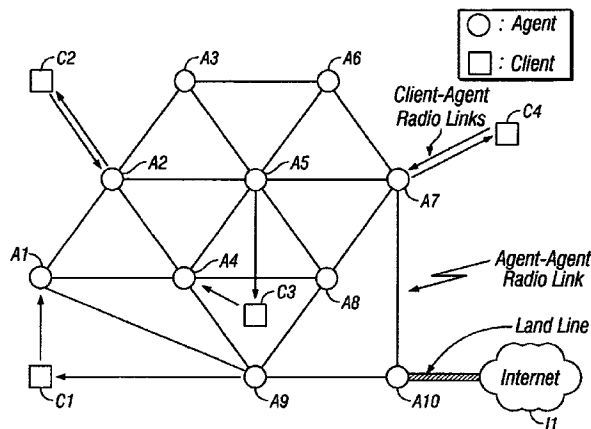

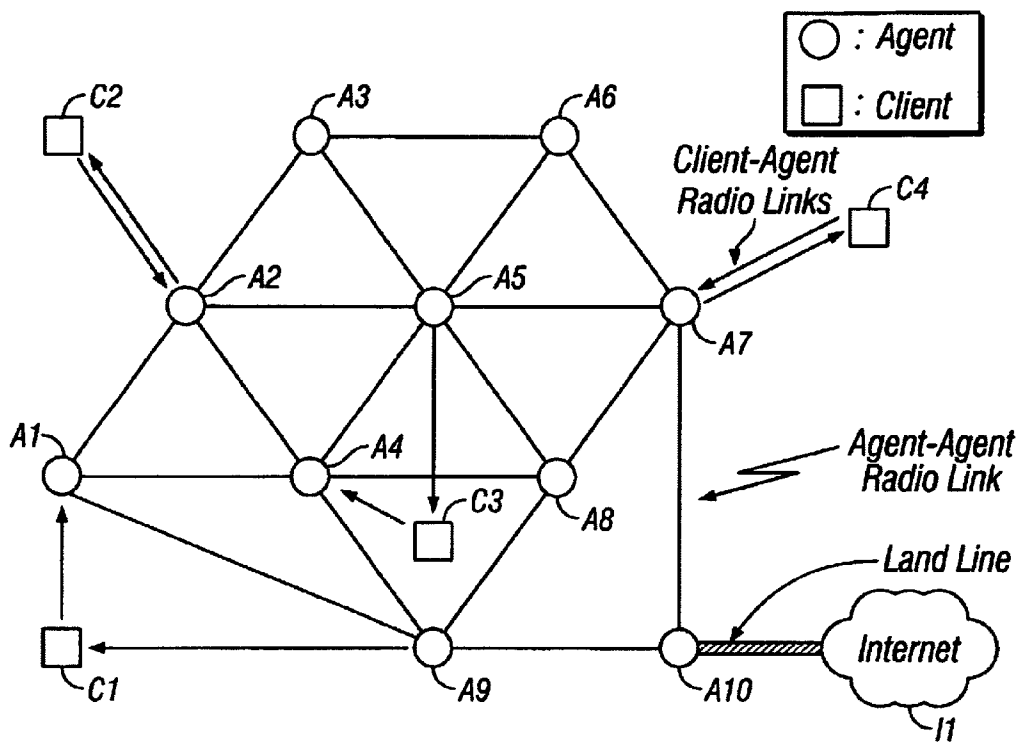

FIG. 1

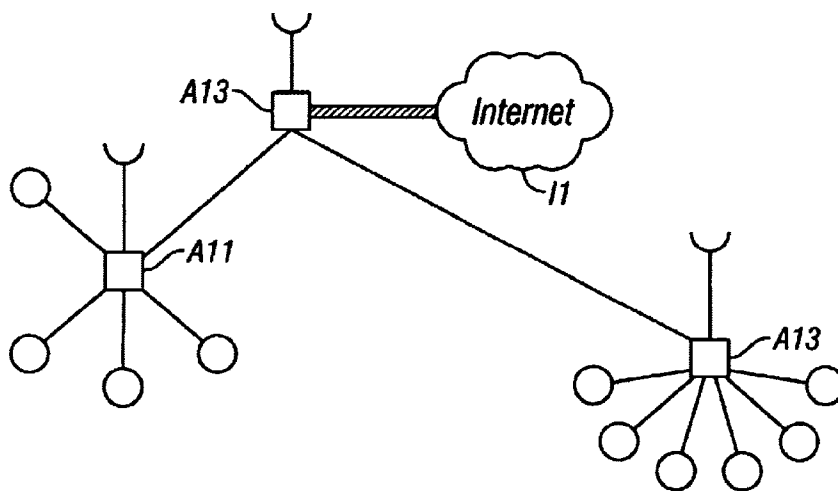

FIG. 2

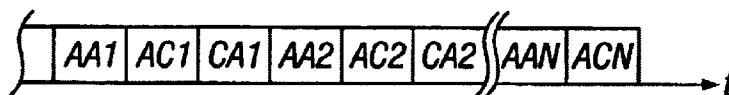

FIG. 3

POWER- AND BANDWIDTH-ADAPTIVE IN-HOME WIRELESS COMMUNICATIONS SYSTEM WITH POWER-GRID-POWERED AGENTS AND BATTERY-POWERED CLIENTS

REFERENCE TO A RELATED PATENT APPLICATION

The present patent application is descended from, and claims benefit of priority of, U.S. Provisional Patent Application Serial No. 60/154,615 filed Sep. 17, 1999, for POWER AND BANDWIDTH ADAPTIVE IN-HOME WIRELESS COMMUNICATIONS SYSTEMS WITH POWER-GRID-POWERED AGENTS AND BATTERY-POWERED CLIENTS to the same inventor as the present application.

BACKGROUND OF THE INVENTION

1. Field of the Invention

The present invention generally concerns wireless communication, including in the home or office.

The present invention particularly concerns power, and bandwidth, management in and for wireless communications systems, most particularly as may be located in the home or office.

The present invention still more particularly concerns power and bandwidth management for wireless communications systems, especially as are used in the home of office, that is adaptive, and tailored to communications conditions.

2. Description of the Prior Art

2.1 Bluetooth and Home RF: Industry Efforts for Wireless Networking

The present invention will be seen to concern power management in and for home and office wireless communications systems. Before specifically considering power management, it is useful to understand just what is the “state of the art” in home and office wireless communications, circa 1999. In this regard, Bluetooth and Home RF are the leading international efforts for wireless networking.

Bluetooth (www.bluetooth.com) is an effort by a consortium of companies to design a universal framework that offers a way to access information based on a diverse set of devices (e.g. PDA, mobile PCs, phones, pagers) in a seamless, user-friendly and efficient manner. Bluetooth envisages a functional and connectivity model based on a combination of wireless access technologies—each matched to different device capabilities and requirements.

Another group of companies has formed the Home RF Working Group or Home RF (www.homerf.org), which has created the Shared Wireless Access Protocol (or SWAP).

The present invention will be seen to be a system and a method that can be implemented by use of the Bluetooth, or the HomeRF, standard and protocol, among other standards and protocols. Review of these wireless communications standards is useful primarily so as to show that the wireless communications links realized by the present invention are neither new nor exotic; circa 2000.

2.2 Bluetooth

“Bluetooth” is each of a consortium, a standard, and a (prospective) class of products. The present invention will be seen to be none of these: it is a system and a method that can be implemented by use of the Bluetooth standard and protocol, among other standards and protocols. Review of Bluetooth is useful primarily so as to show that the wireless communications links realized by the present invention are readily implemented, circa 2000.

A few years ago, the telecommunications and computing industries recognized that a truly low-cost, low-power radio based cable replacement, or wireless link, was feasible. Such a ubiquitous link would provide the basis for small portable devices to communicate together in an ad-hoc fashion. A study was performed, and a technology code named “Bluetooth” began to be defined. The goal was to provide effortless service for mobile and business users by means of a small, short range radio-based technology suitably integrated into production line models of a range of different devices.

Five companies—Ericsson, IBM, Intel, Nokia and Toshiba—teamed up in May, 1998, to address the rising tide of information currently received on mobile computers, cell phones and personal digital assistants. The result was the Bluetooth wireless communications initiative.

As of October, 1998, some 200 companies including 3Com, Compaq, Dell, Hewlett-Packard, Lucent, Motorola, NTT DoCoMo, Philips, Samsung, Siemens and Texas Instruments have joined the Bluetooth Special Interest Group (SIG).

Bluetooth technology is intended to enable users to connect their mobile computers, digital cellular phones, hand-held devices, network access points and other mobile devices via wireless short-range radio links unimpeded by line-of-sight restrictions.

Eliminating the need for proprietary cables to connect devices, Bluetooth technology will increase the ease and breadth of wireless connectivity. Users will be able to automatically receive e-mail on their notebook computers via the digital cellular phones in their pockets, or synchronize their primary PC with their hand-held computer without taking it out of their briefcase.

The overwhelming interest in Bluetooth technology from a wide range of industries demonstrates the growing importance of wireless communication, said Andrew M. Seybold, editor-in-chief, Andrew Seybold's Outlook and keynote speaker at the Bluetooth Developers Conference. Mr. Seybold found the Bluetooth SIG to include the right balance of industry leaders who can make the vision a reality.

The Bluetooth specification version 1.0 was publicly released on Jul. 26, 1999, and product announcements are imminent as of Fall, 1999. Early Bluetooth-enabled products are expected to include mobile computers, hand-held PCs, digital cellular phones and peripherals such as printers, projectors, PC Cards and hands-free head-sets. Network access points will also be available to facilitate access to LANs and WANs.

The core Bluetooth programmed wireless transmitter/receiver is expected to permit a free flow of data without bulky cables. The technology, which ultimately may cost as little as \$5, is designed to work anywhere, even on airplanes.

Low power consumption—drawing only 0.3 mA in standby mode—enables maximum performance longevity for battery-powered devices. During data transfer the maximum current drain is 30 mA. However, during pauses, or at lower data rates, the drain will be lower.

2.3 The HomeRF Working Group

“HomeRF” is also each of a consortium, a standard, and a (prospective) class of products. As before, the present invention will be seen to be none of these, but only susceptible of implementation under the HomeRF standard. Review of HomeRF is useful primarily so as to again show, as with Bluetooth, that the wireless communications links realized by the present invention are readily implemented, circa 2000.

The HomeRF Working Group (HRFWG) was formed to provide the foundation for a broad range of inter-operable

consumer devices by establishing an open industry specification for wireless digital communication. The specification is directed to wireless digital communication between PCs and consumer electronic devices anywhere in and around the home. The HRFWG, which includes the leading companies from the personal computer, consumer electronics, peripherals, communications, software, and semiconductor industries, has developed a specification for wireless communications in the home called the Shared Wireless Access Protocol (SWAP).

To date, the high cost and impracticality of adding new wires have inhibited the widespread adoption of home networking technologies. Wired technologies also do not permit users to roam about with portable devices. In addition, multiple, incompatible communication standards have previously limited acceptance of wireless networks in the home. The HRFWG believes that the open SWAP specification will break through these barriers by (1) enabling inter-operability between many different consumer electronic devices available from a large number of manufacturers, while (2) providing the flexibility and mobility of a wireless solution. This flexibility is important to the success of creating a compelling and complete home network solution.

Since the formation of the HEFWG was announced in March 1998, the total number of member companies has risen to more than 90, and continues to expand quickly. The inclusion of nearly all the leading consumer electronics companies in the working group ensures that consumers will benefit from a wide variety of innovative, inter-operable devices for use in and around the home.

2.3.1 Shared Wireless Access Protocol

The SWAP specification of the HomeRF Working Group (HRFWG) defines a new common interface that supports wireless voice and data networking in the home. Representation from the wide range of member companies, which span diverse industries, ensures that the final specification is complete and robust, and that devices envisioned as part of the home network are inter-operable. The SWAP specification is on target for release at the end of 1998.

Some examples of what users will be able to do with the availability of products that adhere to the SWAP specification include:

- setting up a wireless home network to share voice and data between PC's, peripherals, PC-enhanced cordless phones, and new devices such as portable, remote display pads;
- accessing the Internet from anywhere in and around the home from portable display devices;
- sharing an ISP connection between PC's and other new devices;
- sharing files/modems/printers in multi-PC homes;
- intelligently forwarding incoming telephone calls to multiple cordless handsets, FAX machines and voice mailboxes.
- reviewing incoming voice, FAX and e-mail messages from a small PC-enhanced cordless telephone handset;
- activating other home electronic systems by simply speaking a command into a PC-enhanced cordless handset; and
- enabling multi-player games and/or toys based on PC or Internet resources.

2.4 Issues of Power, and Bandwidth, Utilization Optimization in the Home and Office Wireless Communications Environment

The present invention deals with issues, and problems, regarding the utilization of both (i) power and (ii) bandwidth

in the wireless communications environment, particularly in the home and/or office. These issues and problems are reasonably sophisticated, and sometimes subtle.

It is, of course, immediately obvious that wireless-communicating, normally radio-communicating, devices that are battery-powered should attempt to conserve power to (i) maximize the duration(s) of communication connectivity, and (ii) minimize the duration, frequency, inconvenience and expense of any necessary battery recharging and/or replacement. It is less obvious that there is a tradeoff between battery power and communications bandwidth. Less power may be used to realize a given signal-to-noise ratio if more radio communications bandwidth is used, and vice versa.

Each individual radio-communicating device may normally acceptably use relatively more radio bandwidth without unduly interfering with other devices—which may also desire large communications bandwidths—if the radius of communication is relatively shorter. But how can a short communication radius invariably be assured? And, if sufficient power is normally provided for only but a short communication distance, how can it be assured that enough power will be available should communications need to transpire over a longer distance? And how can it be assured that multiple broadband communicating devices will never be in conflict?

Worse, power and/or bandwidth communications allocations requirements may change (i) over time and (ii) with the location(s) of communicating devices. A intrinsically low-power device, or just a device running low on power, may simply refuse to communicate at a high data rate, or in a high-power channel communications code. Such a low-power device may need a lot of bandwidth to successfully communicate at all. A wireless communications system must accommodate the requirements of communicating both to, and from, such a low-power device.

However, at another time, and/or in another location, another device, or even the same device, may have abundant power, and may reasonably have a requirement to communicate at a high rate and/or in channel communications mode that is of high overall power and/or a narrow bandwidth (i.e., at a high power per unit bandwidth).

The present invention will be seen to (i) present a communications system framework that is intrinsically superior for the home and office wireless communications environment, and then, this framework being established, (ii) show how wireless communications may be dynamically adapted and optimized—both in power and bandwidth—to the exigencies of the moment, communicating optimally for conditions.

SUMMARY OF THE INVENTION

The present invention contemplates a new system organization, and method, for wirelessly communicating within the home or office, and certain new equipments needed to realize this new method.

Major problems associated with wireless at-home networks include (i) the wide variety of devices and applications which must be supported, (ii) cost, (iii) power constraints, and (iv) bandwidth constraints. The present invention deals with these problems in and by a dual strategy: (i) a superior home and office communications system “framework” is adopted, and then, this “framework” being set in place, (ii) wireless communications upon the “framework” is dynamically adapted and optimized in both power and bandwidth.

In the simplest possible terms, the wireless communication system of (i) superior design in accordance with the

present invention is preferably (ii) operated adaptively, realizing superior wireless communication rates and reliability.

1. A Home and Office Wireless Communication System of New Design Uses “Agents”; The “Agents” Make the System Operate in Two Tiers, With Optimization of Communication

The improvement accorded by the present invention to the existing “framework” of home and office wireless communication systems is this: the present invention adds “agents”. In accordance with the present invention, much of the communications power requirement for local, home or office, wireless communication away from “clients” is moved from these “clients” onto a new class of radio-communicating networked devices which include intermediaries in the overall scheme of wireless communications and are referred herein as “agents.” Examples for “clients” include, among others, functional devices such as telephones, computers, televisions, key pad controllers, burglar alarms, household appliances, and hybrids thereof. These abundant, low-cost, agents are essentially non-power-limited radio-frequency transceivers that plug inconspicuously into otherwise unused wall power outlets of the home or business. The agents may physically resemble surge protectors.

The agents are reasonably capable and “intelligent” to self-organize into communications networks, as will be discussed. They are typically more capable than are the system clients, which are relegated to wireless communicating only with agents along but a few wireless links.

Although some clients, notably including non-portable species of computers and larger televisions, heavy appliances, and burglar alarms, are permanently connected to the power grid, other battery-powered clients, notably including telephones, portable computers and portable radios and televisions, can immediately benefit from the present invention’s re-partitionment of the “framework” of wireless communications. This is because the power requirements for these clients are sharply reduced: the clients need normally wirelessly communicate only to a very nearby agent a power-grid-powered wall-plugged radio frequency transceiver that is normally within the same room. Certainly, some clients that are permanently connected to the power grid may also be beneficially combined with agents.

Next, the same re-partitionment simultaneously beneficially conserves local radio frequency bandwidth. A client, especially a battery-powered mobile client, wirelessly communicates only with that agent to which it is electrophysically closest, normally over a distance of but a few meters. Very little radio frequency power need be used and, in accordance with the present invention, is used. The communications of other clients with other agents elsewhere in the same home or business is non-interfering (by action of agent-network-controlled agent-client communication, as will be explained).

The same re-partitionment also has a benevolent, or at worst a neutral, effect on issues of cost and diversity of devices supported. Basically, the abundantly-produced and liberally-sited ubiquitous wall-powered agents (i) eliminate, or at least mitigate, some of the requirements for (a) power, and/or for (b) sophistication in power management, in wirelessly-communicating home and/or office client devices. Meanwhile, the agents (ii) simultaneously lessen constraints, and/or any required sophistication, in the use of RF bandwidth by these client devices. Therefore, and although the agents—the wall-powered RF transceiver modules—are reasonably sophisticated (in accordance with existing communications protocols) in self-organizing into a

wireless communications network, and are thus estimated to cost some few dollars each, the agents potentially (i) diminish demands on other home/office wireless communications system components, while (ii) adding great value to home/office wireless communications system performance.

The present invention is of good utility and effect just by addition of the agents, without more. However, once the agents are inserted into a home or office wireless communications system, the present invention contemplates still further improvements.

1.2 The Agents are Intelligent, Endowing the Wireless Communications Network Upon Which They are Distributed With “Adaptive Intelligence” as Permits Communication Optimization

The agents are not merely radio repeaters. They also implement an expandable, open-ended, dynamic, distributed radio communications management system.

The collective agents—the distributed radio communications management system—a) registers clients (either at-home or visiting), b) authenticates visitors, c) maintains a link to external networks (e.g., to the PSTN, or the Internet), d) self-organizes a communications mesh e) implementing the MAC protocol, f) implements the LLC protocol, g) maintains link addresses for all clients and agents, and, most importantly, h) adapts the mesh, and the communications upon the mesh, to the numbers, powers and instantaneous communications requirements of the clients then connected on and by the communications mesh.

Little of this functionality is earthshaking, being that it has, by and large, recently come to exist in cellular and other mesh communications networks. In the past, however, the digital “intelligence” associated with communications system management has been reserved for physically large, geographically extensive, communications systems such as might typically serve a town or a city. The present invention has the “audacity” to bring the most powerful mesh communications methods—developed over decades at immense cost but as are now increasingly implemented in application specific integrated circuit chips—directly into the smallest environment: the home or office. Exactly because this environment is the “poorest” in every way—in power, in bandwidth, and in the confusingly high diversity of low sophistication communicating equipments—it is the very environment that can most benefit from the application of state-of-the-art sophisticated distributed communications control methodology. This is exactly the present invention teaches to do.

1.3 A Two-Tier Wireless Communications Network

The agents and clients of the present invention implement a “two-tier” wireless communications system. The invention may thus be thought of as a “two-tier” wireless communications system, and/or to be embodied in a “two-tier” wireless communications system. The “two tiers” are tiers of a communications hierarchy: in a first communications tier the agents communicate with other agents; in a second communications tier the local clients of each agent communicate with that agent.

Communications in each of the two tiers may be, and preferably is, separately conducted from communications in the other tier—but need not be so separated and divided. For example, in one embodiment of the “two-tier” wireless communications system of the present invention communications between agents in one tier is at a different radio frequency than communication between an agent and its associated clients otherwise transpiring in the other tier. In another embodiment of the “two-tier” wireless communications system of the present invention communications

Explore Litigation Insights

Docket Alarm provides insights to develop a more informed litigation strategy and the peace of mind of knowing you're on top of things.

Real-Time Litigation Alerts



Keep your litigation team up-to-date with **real-time alerts** and advanced team management tools built for the enterprise, all while greatly reducing PACER spend.

Our comprehensive service means we can handle Federal, State, and Administrative courts across the country.

Advanced Docket Research



With over 230 million records, Docket Alarm's cloud-native docket research platform finds what other services can't. Coverage includes Federal, State, plus PTAB, TTAB, ITC and NLRB decisions, all in one place.

Identify arguments that have been successful in the past with full text, pinpoint searching. Link to case law cited within any court document via Fastcase.

Analytics At Your Fingertips



Learn what happened the last time a particular judge, opposing counsel or company faced cases similar to yours.

Advanced out-of-the-box PTAB and TTAB analytics are always at your fingertips.

API

Docket Alarm offers a powerful API (application programming interface) to developers that want to integrate case filings into their apps.

LAW FIRMS

Build custom dashboards for your attorneys and clients with live data direct from the court.

Automate many repetitive legal tasks like conflict checks, document management, and marketing.

FINANCIAL INSTITUTIONS

Litigation and bankruptcy checks for companies and debtors.

E-DISCOVERY AND LEGAL VENDORS

Sync your system to PACER to automate legal marketing.