

1 17. A method of dithering watermark quantizations such that the
2 dither changes an absolute quantization value, but does not change a
3 quantization level or information carried in the quantization.

1 18. A method of encoding watermarks comprising steps of:
2 inverting at least one instance of the watermark bit stream; and
3 encoding at least one instance of the watermark using said inverted
4 instance of the watermark bit stream.

1 19. A method of decoding watermarks comprising steps of:
2 considering an original watermark synchronization marker, an inverted
3 watermark synchronization marker, and inverted watermarks; and
4 decoding based on the considering step.

1 20. A method of encoding and decoding watermarks in a signal
2 using a spread spectrum technique to encode or decode where information is
3 encoded or decoded at audible levels and the encoding and decoding
4 methods are pseudo-random over frequency.

1 21. A method of encoding and decoding watermarks in a signal
2 using a spread spectrum technique to encode or decode where information is
3 encoded or decoded at audible levels and the encoding and decoding
4 methods are pseudo-random over time.

1 22. The method of claim 21, wherein the information is encoded or
2 decoded at audible levels and the encoding and decoding methods are
3 pseudo-random, over both frequency and time.

1 23. A method of analyzing composite digitized signals for
2 watermarks comprising steps of:

3 obtaining a composite signal;
4 obtaining an unwatermarked sample signal;
5 time aligning the unwatermarked sample signal to the
6 composite signal;
7 gain adjusting the time aligned unwatermarked sample signal to
8 a corresponding segment of the composite signal, determined in the
9 time aligning step;
10 estimating a pre-composite signal using the composite signal
11 and the gain adjusted unwatermarked sample signal;
12 estimating a watermarked sample signal by subtracting the
13 estimated pre-composite signal from the composite signal; and
14 scanning the estimated watermarked sample signal for
15 watermarks.

1 24. A method for varying watermark encode/decode algorithms
2 automatically during the encoding or decoding of a watermark comprising
3 steps of:
4 a) assigning a list of desired CODECs to a list of corresponding
5 signal characteristics which indicate use of particular CODECs;
6 b) during encoding/decoding, analyzing characteristics of the
7 current sample frame in the signal stream, prior to delivering the frame to a
8 CODEC;
9 c) looking up the corresponding CODEC from the list of CODECs
10 in step (a) which matches the observed signal characteristics from step (b);
11 d) loading and/or preparing the desired CODEC;
12 e) passing the sample frame to the CODEC selected in step (c);
13 and
14 f) receiving the output samples from step (e).

1 25. The method according to claim 24, wherein watermark signal
2 characteristics or a watermark certificate can be compressed.

- 1 26. A method for varying watermark encode/decode algorithms
2 automatically during the encoding or decoding of a watermark comprising
3 steps of:
- 4 a) assigning a list of desired CODECs to a list of index values
5 which correspond to values computed as a function of the pseudo-random
6 watermark key and the state of the processing framework;
 - 7 b) during encoding/decoding, computing the pseudo-random key
8 index value for the current sample frame in the signal stream, prior to
9 delivering the frame to a CODEC;
 - 10 c) looking up the corresponding CODEC from the list of CODECs
11 in step (a) which matches the index value from step (b);
 - 12 d) loading and/or preparing the desired CODEC;
 - 13 e) passing the sample frame to the CODEC selected in step (c);
 - 14 and
 - 15 f) receiving the output samples from step (e).
- 1 27. The method according to claim 26, wherein watermark signal
2 characteristics or a watermark certificate can be compressed.

INTERNATIONAL SEARCH REPORT

International application No.
PCT/US97/11455

A. CLASSIFICATION OF SUBJECT MATTER		
IPC(6) :G09C 5/00 H04L 9/00 US CL :380/54, 3, 4, 23, 55; 283/73, 113, 17 According to International Patent Classification (IPC) or to both national classification and IPC		
B. FIELDS SEARCHED		
Minimum documentation searched (classification system followed by classification symbols) U.S. : 380/54, 3, 4, 23, 55, 49, 51, 59; 283/73, 113, 17		
Documentation searched other than minimum documentation to the extent that such documents are included in the fields searched		
Electronic data base consulted during the international search (name of data base and, where practicable, search terms used)		
C. DOCUMENTS CONSIDERED TO BE RELEVANT		
Category*	Citation of document, with indication, where appropriate, of the relevant passages	Relevant to claim No.
A, E	US 5,664,018 A (LEIGHTON) 02 SEPTEMBER 1997	1-27
A, P	US, 5,636,292 A (RHOADS) 03 JUNE 1997	1-27
A, P	US 5,617,119 A (BRIGGS ET AL.) 01 APRIL 1997	1-27
A, P	US 5,568,570 A (RABBANI) 22 OCTOBER 1996	1-27
A, P	US 5,530,759 A (BRAUDAWAY, ET AL.) 25 JUNE 1996	1-27
A	US 5,493,677 A (BALOGH, ET AL.) 20 FEBRUARY 1996	1-27
<input type="checkbox"/> Further documents are listed in the continuation of Box C. <input type="checkbox"/> See patent family annex.		
* Special categories of cited documents: *A* document defining the general state of the art which is not considered to be of particular relevance *E* earlier document published on or after the international filing date *L* document which may throw doubts on priority claim(s) or which is cited to establish the publication date of another citation or other special reason (as specified) *O* document referring to an oral disclosure, use, exhibition or other means *P* document published prior to the international filing date but later than the priority date claimed *T* later document published after the international filing date or priority date and not in conflict with the application but cited to understand the principle or theory underlying the invention *X* document of particular relevance; the claimed invention cannot be considered novel or cannot be considered to involve an inventive step when the document is taken alone *Y* document of particular relevance; the claimed invention cannot be considered to involve an inventive step when the document is combined with one or more other such documents, such combination being obvious to a person skilled in the art *Z* document member of the same patent family		
Date of the actual completion of the international search 23 OCTOBER 1997		Date of mailing of the international search report 23 DEC 1997
Name and mailing address of the ISA/US Commissioner of Patents and Trademarks Box PCT Washington, D.C. 20231 Facsimile No. (703) 305-3230		Authorized officer <i>David Cain</i> DAVID CAIN Telephone No. (703) 305-1836



INTERNATIONAL APPLICATION PUBLISHED UNDER THE PATENT COOPERATION TREATY (PCT)

<p>(51) International Patent Classification ⁷ : H04N 7/167</p>	<p>A1</p>	<p>(11) International Publication Number: WO 00/57643 (43) International Publication Date: 28 September 2000 (28.09.00)</p>
<p>(21) International Application Number: PCT/US00/06522 (22) International Filing Date: 14 March 2000 (14.03.00) (30) Priority Data: 60/125,990 24 March 1999 (24.03.99) US (71) Applicant (for all designated States except US): BLUE SPIKE, INC. [US/US]; 16711 Collins Avenue, Miami, FL 33160 (US). (72) Inventors; and (75) Inventors/Applicants (for US only): MOSKOWITZ, Scott, A. [US/US]; 16711 Collins Avenue, Miami, FL 33160 (US). BERRY, Michael [US/US]; 12401 Princess Jeanne, Albuquerque, NM 87112 (US). (74) Agents: CHAPMAN, Floyd, B. et al.; Baker Botts, L.L.P., 1299 Pennsylvania Avenue, N.W., Washington, DC 20004 (US).</p>		<p>(81) Designated States: JP, US, European patent (AT, BE, CH, CY, DE, DK, ES, FI, FR, GB, GR, IE, IT, LU, MC, NL, PT, SE). Published <i>With international search report.</i> <i>Before the expiration of the time limit for amending the claims and to be republished in the event of the receipt of amendments.</i></p>

(54) Title: UTILIZING DATA REDUCTION IN STEGANOGRAPHIC AND CRYPTOGRAPHIC SYSTEMS

(57) Abstract

The present invention is a method for protecting a data signal where the method comprises the following steps: applying a data reduction technique (200) to the signal to produce a reduced signal, subtracting (60) the reduced data signal from the original signal to produce a remainder signal (39), embedding (300) a first watermark into the reduced data signal to produce a watermarked reduced data signal, and adding (50) the watermarked reduced signal to the remainder signal to produce an output signal (90). A second watermark (301) may be embedded into the remainder signal (39) before the final addition (50) step. Cryptographic techniques may be employed to encrypt the remainder signal and/or the reduced signal prior to the addition step (50).

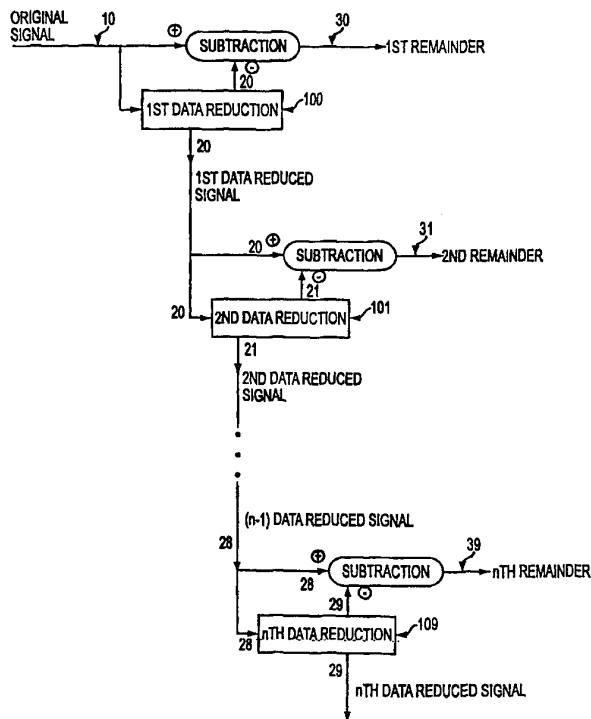

FOR THE PURPOSES OF INFORMATION ONLY

Codes used to identify States party to the PCT on the front pages of pamphlets publishing international applications under the PCT.

AL	Albania	ES	Spain	LS	Lesotho	SI	Slovenia
AM	Armenia	FI	Finland	LT	Lithuania	SK	Slovakia
AT	Austria	FR	France	LU	Luxembourg	SN	Senegal
AU	Australia	GA	Gabon	LV	Latvia	SZ	Swaziland
AZ	Azerbaijan	GB	United Kingdom	MC	Monaco	TD	Chad
BA	Bosnia and Herzegovina	GE	Georgia	MD	Republic of Moldova	TG	Togo
BB	Barbados	GH	Ghana	MG	Madagascar	TJ	Tajikistan
BE	Belgium	GN	Guinea	MK	The former Yugoslav Republic of Macedonia	TM	Turkmenistan
BF	Burkina Faso	GR	Greece			TR	Turkey
BG	Bulgaria	HU	Hungary	ML	Mali	TT	Trinidad and Tobago
BJ	Benin	IE	Ireland	MN	Mongolia	UA	Ukraine
BR	Brazil	IL	Israel	MR	Mauritania	UG	Uganda
BY	Belarus	IS	Iceland	MW	Malawi	US	United States of America
CA	Canada	IT	Italy	MX	Mexico	UZ	Uzbekistan
CF	Central African Republic	JP	Japan	NE	Niger	VN	Viet Nam
CG	Congo	KE	Kenya	NL	Netherlands	YU	Yugoslavia
CH	Switzerland	KG	Kyrgyzstan	NO	Norway	ZW	Zimbabwe
CI	Côte d'Ivoire	KP	Democratic People's Republic of Korea	NZ	New Zealand		
CM	Cameroon			PL	Poland		
CN	China	KR	Republic of Korea	PT	Portugal		
CU	Cuba	KZ	Kazakstan	RO	Romania		
CZ	Czech Republic	LC	Saint Lucia	RU	Russian Federation		
DE	Germany	LI	Liechtenstein	SD	Sudan		
DK	Denmark	LK	Sri Lanka	SE	Sweden		
EE	Estonia	LR	Liberia	SG	Singapore		

UTILIZING DATA REDUCTION IN STEGANOGRAPHIC AND CRYPTOGRAPHIC SYSTEMS

FIELD OF INVENTION

This invention relates to digital signal processing, and more particularly to a method and a system for encoding at least one digital watermark into a signal as a means of conveying information relating to the signal and also protecting against unauthorized manipulation of the signal.

BACKGROUND OF INVENTION

Digital watermarks help to authenticate the content of digitized multimedia information, and can also discourage piracy. Because piracy is clearly a disincentive to the digital distribution of copyrighted content, establishment of responsibility for copies and derivative copies of such works is invaluable. In considering the various forms of multimedia content, whether "master," stereo, NTSC video, audio tape or compact disc, tolerance of quality will vary with individuals and affect the underlying commercial and aesthetic value of the content. It is desirable to tie copyrights, ownership rights, purchaser information or some combination of these and related data into the content in such a manner that the content must undergo damage, and therefore reduction of its value, with subsequent, unauthorized distribution, commercial or otherwise. Digital watermarks address many of these concerns.

A matter of general weakness in digital watermark technology relates directly to the manner of implementation of the watermark. Many approaches to digital watermarking leave detection and decode control with the implementing party of the digital watermark, not the creator of the work to be protected. This weakness removes proper economic incentives for improvement of the technology. One specific form of exploitation mostly regards efforts to obscure subsequent watermark detection. Others regard successful over encoding using the same watermarking process at a subsequent time. Yet another way to perform secure digital watermark implementation is through "key-based" approaches.

This paper draws a distinction between a "forensic watermark," based on provably-secure methods, and a "copy control" or "universal" watermark which is intended to be low cost and easily implemented into any general computing or consumer electronic device. A watermark can be forensic if it can identify the source of the data from which a copy was made. For example, assume that digital data are stored on a disk and provided to "Company A" (the "A disk"). Company A makes an unauthorized copy and delivers the copy to "Company B" (the "B disk"). A forensic watermark, if present in the digital data stored on the "A disk," would identify the "B disk" as having been copied from the "A disk."

On the other hand, a copy control or universal watermark is an embedded signal which is governed by a "key" which may be changed (a "session key") to increase security, or one that is easily accessible to devices that may offer less than strict cryptographic security. The "universal" nature of the watermark is the computationally inexpensive means for accessing or other associating the watermark with operations that can include playback, recording or manipulations of the media in which it is embedded.

A fundamental difference is that the universality of a copy control mechanism, which must be redundant enough to survive many signal manipulations to eliminate most casual piracy, is at odds with the far greater problem of establishing responsibility for a given instance of a suspected copying of a copyrighted media work. The more dedicated pirates must be dealt with by encouraging 3rd party authentication with "forensic watermarks" or those that constitute "transactional watermarks" (which are encoded in a given copy of said content to be watermarked as per the given transaction).

The goal of a digital watermark system is to insert a given information signal or signals in such a manner as to leave little or no evidence of the presence of the information signal in the underlying content signal. A separate but equal goal is maximizing the digital watermark's encoding level and "location sensitivity" in the underlying content signal such that the watermark cannot be removed without damage to the content signal.

One means of implementing a digital watermark is to use key-based security. A predetermined or random key can be generated as a map to access the hidden information signal. A key pair may also be used. With a typical key pair, a party possesses a public and a private key. The private key is maintained in confidence by the owner of the key, while the owner's public key is disseminated to those persons in the public with whom the owner would regularly communicate. Messages being communicated, for example by the owner to another, are encrypted with the private key and can only be read by another person who possesses the corresponding public key. Similarly, a message encrypted with the person's public key can only be decrypted with the corresponding private key. Of course, the keys or key pairs may be processed in separate software or hardware devices handling the watermarked data.

SUMMARY OF THE INVENTION

A method of securing a data signal comprises the steps of: applying a data reduction technique to reduce the data signal into a reduced data signal; subtracting said reduced data signal from the data signal to produce a remainder signal; using a first cryptographic technique to encrypt the reduced data signal to produce an encrypted, reduced data signal; using a second cryptographic technique to encrypt the remainder signal to produce an encrypted remainder signal; and adding said encrypted, reduced data signal to said encrypted remainder signal to produce an output signal.

A system for securing a data signal comprises: means to apply a data reduction technique to reduce the data signal into a reduced data signal; means to subtract said reduced data signal from the data signal to produce a remainder signal; means to apply a first cryptographic technique to encrypt the reduced data signal to produce an encrypted, reduced data signal; means to apply a second cryptographic technique to encrypt the remainder signal to produce an encrypted remainder signal; and means to add said encrypted, reduced data signal to said encrypted remainder signal to produce an output signal.

A method of securing a data signal comprises the steps of: applying a data reduction technique to reduce the data signal into a reduced data signal; subtracting said reduced data signal from the data signal to produce a remainder signal; embedding a first watermark into said reduced data signal to produce a watermarked, reduced data signal; embedding a second watermark into said remainder signal to produce a watermarked remainder signal; and adding said watermarked, reduced data signal to said watermarked remainder signal to produce an output signal.

A method of protecting a data signal comprises: applying a data reduction technique to reduce the data signal into a reduced data signal; subtracting said reduced data signal from the data signal to produce a remainder signal; using a first scrambling technique to scramble said reduced data signal to produce a scrambled, reduced data signal; using a second scrambling technique to scramble said remainder signal to produce a scrambled remainder signal; and adding said scrambled, reduced data signal to said scrambled remainder signal to produce an output signal.

There are two design goals in an overall digital watermarking system's low cost, and universality. Ideally, a method for encoding and decoding digital watermarks in digitized media for copy control purposes should be inexpensive and universal. This is essential in preventing casual piracy. On the other hand, a more secure form of protection, such as a "forensic watermarks," can afford to be computationally intensive to decode, but must be unaffected by repeated re-encoding of a copy control watermark. An ideal method for achieving these results would separate the signal into different areas, each of which can be accessed independently. The embedded signal or may simply be "watermark bits" or "executable binary code," depending on the application and type of security sought. Improvements to separation have been made possible by enhancing more of the underlying design to meet a number of clearly problematic issues. The present invention interprets the signal as a stream which may be split into separate streams of digitized samples or may undergo data reduction (including both lossy and lossless compression, such as MPEG lossy compression and Meridian's lossless compression, down sampling, common to many studio operations, or any

related data reduction process). The stream of data can be digital in nature, or may also be an analog waveform (such as an image, audio, video, or multimedia content). One example of digital data is executable binary code. When applied to computer code, the present invention allows for more efficient, secure, copyright protection when handling functionality and associations with predetermined keys and key pairs in software applications or the machine readable versions of such code in microchips and hardware devices. Text may also be a candidate for authentication or higher levels of security when coupled with secure key exchange or asymmetric key generation between parties. The subsets of the data stream combine meaningful and meaningless bits of data which may be mapped or transferred depending on the application intended by the implementing party.

The present invention utilizes data reduction to allow better performance in watermarking as well as cryptographic methods concerning binary executable code, its machine readable form, text and other functionality-based or communication-related applications. Some differences may simply be in the structure of the key itself, a pseudo random or random number string or one which also includes additional security with special one way functions or signatures saved to the key. The key may also be made into key pairs, as is discussed in other disclosures and patents referenced herein. The present invention contemplates watermarks as a plurality of digitized sample streams, even if the digitized streams originate from the analog waveform itself. The present invention also contemplates that the methods disclosed herein can be applied to non-digitized content. Universally, data reduction adheres to some means of "understanding" the reduction. This disclosure looks at data reduction which may include down sampling, lossy compression, summarization or any means of data reduction as a novel means to speed up watermarking encode and decode operations. Essentially a lossy method for data reduction yields the best results for encode and decode operations.

It is desirable to have both copy control and forensic watermarks in the same signal to address the needs of the hardware, computer, and software industries while

also providing for appropriate security to the owners of the copyrights. This will become clearer with further explanation of the sample embodiments discussed herein.

The present invention also contemplates the use of data reduction for purposes of speedier and more tiered forms of security, including combinations of these methods with transfer function functions. In many applications, transfer functions (e.g., scrambling), rather than mapping functions (e.g., watermarking), are preferable or can be used in conjunction with mapping. With "scrambling," predetermined keys are associated with transfer functions instead of mapping functions, although those skilled in the art may recognize that a transfer function is simply a subset of mask sets encompassing mapping functions. It is possible that tiered scrambling with data reduction or combinations of tiered data reduction with watermarking and scrambling may indeed increase overall security to many applications.

The use of data reduction can improve the security of both scrambling and watermarking applications. All data reduction methods include coefficients which affect the reduction process. For example, when a digital signal with a time or space component is down sampled, the coefficient would be the ratio of the new sample rate to the original sample rate. Any coefficients that are used in the data reduction can be randomized using the key, or key pair, making the system more resistant to analysis. Association to a predetermined key or key pair and additional measure of security may include biometric devices, tamper proofing of any device utilizing the invention, or other security measures.

Tests have shown that the use of data reduction in connection with digital watermarking schemes significantly reduces the time required to decode the watermarks, permitting increases in operational efficiency.

Particular implementations of the present invention, which have yielded incredibly fast and inexpensive digital watermarking systems, will now be described. These systems may be easily adapted to consumer electronic devices, general purpose computers, software and hardware. The exchange of predetermined keys or key pairs may facilitate a given level of security. Additionally, the complementary increase in

security for those implementations where transfer functions are used to "scramble" data, is also disclosed.

BRIEF DESCRIPTION OF THE DRAWINGS

For a more complete understanding of the invention and some advantages thereof, reference is now made to the following descriptions taken in connection with the accompanying drawings in which:

FIG. 1 is a functional block diagram that shows a signal processing system that generates "n" remainder signals and "n" data reduced signals.

FIG. 2 is a functional block diagram for an embodiment of the present invention which illustrates the generation of an output signal comprised of a data-reduced, watermarked signal and a first remainder signal.

FIG. 3 is a functional block diagram for an embodiment of the present invention which illustrates the generation of an output signal comprised of a data-reduced, watermarked signal and a watermarked, first remainder signal.

FIG. 4 is a functional block diagram for decoding the output signal generated by the system illustrated in FIG. 2.

FIG. 5 is a functional block diagram for decoding the output signal generated by the system illustrated in FIG. 3.

FIG. 6 is a functional block diagram for an embodiment of the present invention which illustrates the generation of an output signal comprised of a data-reduced, scrambled signal and a first remainder signal.

FIG. 7 is a functional block diagram for an embodiment of the present invention which illustrates the generation of an output signal comprised of a data-reduced, scrambled signal and a scrambled, first remainder signal.

FIG. 8 is a functional block diagram for decoding the output signal generated by the system illustrated in FIG. 6.

FIG. 9 is a functional block diagram for decoding the output signal generated by the system illustrated in FIG. 7.

DETAILED DESCRIPTION

The embodiments of the present invention and its advantages are best understood by referring to the drawings, like numerals being used for like and corresponding parts of the various drawings.

An Overview

A system for achieving multiple levels of data reduction is illustrated in FIG. 1. An input signal 10 (for example, instructional text, executable binary computer code, images, audio, video, multimedia or even virtual reality imaging) is subjected to a first data reduction technique 100 to generate a first data reduced signal 20. First data reduced signal 20 is then subtracted from input signal 10 to generate a first remainder signal 30.

First data reduced signal 20 is subjected to a second data reduction technique 101 to generate a second data reduced signal 21. Second data reduced signal 21 is then subtracted from first data reduced signal 20 to generate a second remainder signal 31.

Each of the successive data reduced signals is, in turn, subjected to data reduction techniques to generate a further data reduced signal, which, in turn, is subtracted from its respective parent signal to generate another remainder signal. This process is generically described as follows. An $(n-1)$ data reduced signal 28 (i.e., a signal that has been data reduced $n-1$ times) is subjected to an n th data reduction technique 109 to generate an n th data reduced signal 29. The n th data reduced signal 29 is then subtracted from the $(n-1)$ data reduced signal 28 to produce an n^{th} remainder signal 39.

An output signal can be generated from the system illustrated in FIG. 1 in numerous ways. For example, each of the n remainder signals (which, through represented by reference numerals 30-39, are not intended to be limited to 10 signals) and the n^{th} data signal may optionally be subjected to a watermarking technique, or even optionally be subjected to an encryption technique, and each of the $(n+1)$ signals (whether

watermarked or encrypted, or otherwise untouched) may then be added together to form an output signal. By way of more particular examples, each of the (n+1) signals (i.e., the n remainder signals and the nth data reduced signal) can be added together without any encryption or watermarking to form an output signal; or one or more of the (n+1) signals may be watermarked and then all (n+1) signals may be added together; or one or more of the (n+1) signals may be encrypted and then all (n+1) signals may be added together. It is anticipated that between these three extremes lie numerous hybrid combinations involving one or more encryptions and one or more watermerkings.

Each level may be used to represent a particular data density. E.g., if the reduction method is down-sampling, for a DVD audio signal the first row would represent data sampled at 96 kHz, the second at 44.1 kHz., the third at 6 kHz., etc. There is only an issue of deciding what performance or security needs are contemplated when undertaking the data reduction process and choice of which types of keys or key pairs should be associated with the signal or data to be reduced. Further security can be increased by including block ciphers, special one way functions, one time stamps or even biometric devices in the software or hardware devices that can be embodied. Passwords or biometric data are able to assist in the determination of the identity of the user or owner of the data, or some relevant identifying information.

An example of a real world application is helpful here. Given the predominant concern, at present, of MPEG 1 Layer 3, or MP3, a perceptual lossy compression audio data format, which has contributed to a dramatic re-evaluation of the distribution of music, a digital watermark system must be able to handle casual and more dedicated piracy in a consistent manner. The present invention contemplates compatibility with MP3, as well as any perceptual coding technique that is technically similar. One issue, is to enable a universal copy control "key" detect a watermark as quickly as possible from a huge range of perceptual quality measures. For instance, DVD 24 bit 96 kHz, encoded watermarks, should be detected in at least "real time," even after the signal has been down sampled, to say 12 kHz of the 96 kHz originally referenced. By delineating and starting with less data, since the data-reduced signal is obviously smaller though

still related perceptually to the original DVD signal, dramatic increases in the speed and survival of the universal copy control bits can be achieved. The present invention also permits the ability to separate any other bits which may be associated with other more secure predetermined keys or key pairs.

Where the data stream is executable computer code, the present invention contemplates breaking the code into objects or similar units of functionality and allowing for determination of what is functionally important. This may be more apparent to the developer or users of the software or related hardware device. Data reduction through the use of a subset of the functional objects related to the overall functionality of the software or executable code in hardware or microchips, increase the copyright protection or security sought, based on reducing the overall data to be associated with predetermined keys or key pairs. Similarly, instead of mapping functions, transfer functions, so-called "scrambling," appear better candidates for this type of security although both mapping and transferring may be used in the same system. By layering the security, the associated keys and key pairs can be used to substantially improve the security and to offer easier methods for changing which functional "pieces" of executable computer code are associated with which predetermined keys. These keys may take the form of time-sensitive session keys, as with transactions or identification cards, or more sophisticated asymmetric public key pairs which may be changed periodically to ensure the security of the parties' private keys. These keys may also be associated with passwords or biometric applications to further increase the overall security of any potential implementation.

An example for text message exchange is less sophisticated but, if it is a time sensitive event, e.g., a secure communication between two persons, benefits may also be encountered here. Security may also be sought in military communications. The ability to associate the securely exchanged keys or key pairs while performing data reduction to enhance the detection or decoding performance, while not compromising the level of security, is important. Though a steganographic approach to security, the present invention more particularly addresses the ability to have data reduction to

increase speed, security, and performance of a given steganographic system. Additionally, data reduction affords a more layered approach when associating individual keys or key pairs with individual watermark bits, or digital signature bits, which may not be possible without reduction because of considerations of time or the payload of what can be carried by the overall data "coverttext" being transmitted.

Layering through data reduction offers many advantages to those who seek privacy and copyright protection. Serialization of the detection chips or software would allow for more secure and less "universal" keys, but the interests of the copyright owners are not always aligned with those of hardware or software providers. Similarly, privacy concerns limit the amount of watermarking that can be achieved for any given application. The addition of a pre-determined and cryptographic key-based "forensic" watermark, in software or hardware, allows for 3rd party authentication and provides protection against more sophisticated attacks on the copy control bits. Creating a "key pair" from the "predetermined" key is also possible.

Separation of the watermarks also relates to separate design goals. A copy control mechanism should ideally be inexpensive and easily implemented, for example, a form of "streamed watermark detection." Separating the watermark also may assist more consistent application in broadcast monitoring efforts which are time-sensitive and ideally optimized for quick detection of watermarks. In some methods, the structure of the key itself, in addition to the design of the "copy control" watermark, will allow for few false positive results when seeking to monitor radio, television, or other streamed broadcasts (including, for example, Internet) of copyrighted material. As well, inadvertent tampering with the embedded signal proposed by others in the field can be avoided more satisfactorily. Simply, a universal copy control watermark may be universal in consumer electronic and general computing software and hardware implementations, but less universal when the key structure is changed to assist in being able to log streaming, performance, or downloads, of copyrighted content. The embedded bits may actually be paired with keys in a decode device to assure accurate broadcast monitoring and tamper proofing, while not requiring a watermark to exceed

the payload available in an inaudible embedding process. E.g., A full identification of the song, versus time-based digital signature bits, embedded into a broadcast signal, may not be recovered or may be easily over encoded without the use of block ciphers, special one way functions or one time pads, during the encoding process, prior to broadcast. Data reduction as herein disclosed makes this operation more efficient at higher speeds.

A forensic watermark is not time sensitive, is file-based, and does not require the same speed demands as a streamed or broadcast-based detection mechanism for copy control use. Indeed, a forensic watermark detection process may require additional tools to aid in ensuring that the signal to be analyzed is in appropriate scale or size, ensuring signal characteristics and heuristic methods help in appropriate recovery of the digital watermark. Simply, all aspects of the underlying content signal should be considered in the embedding process because the watermarking process must take into account all such aspects, including for example, any dimensional or size of the underlying content signal. The dimensions of the content signal may be saved with the key or key pair, without enabling reproduction of the unwatermarked signal. Heuristic methods may be used to ensure the signal is in proper dimensions for a thorough and accurate detection authentication and retrieval of the embedded watermark bits. Data reduction can assist in increasing operations of this nature as well, since the data reduction process may include information about the original signal, for example, signal characteristics, signal abstracts, differences between samples, signal patterns, and related work in restoring any given analog waveform.

The present invention provides benefits, not only because of the key-based approach to the watermarking, but the vast increase in performance and security afforded the implementations of the present invention over the performance of other systems.

The architecture of key and key-pair based watermarking is superior to statistical approaches for watermark detection because the first method meets an evidentiary level of quality and are mathematically provable. By incorporating a level

of data reduction, key and key paired based watermarking is further improved. Such levels of security are plainly necessary if digital watermarks are expected to establish responsibility for copies of copyrighted works in evidentiary proceedings. More sophisticated measures of trust are necessary for use in areas which exceed the scope of copyright but are more factually based in legal proceedings. These areas may include text authentication or software protection (extending into the realm of securing microchip designs and compiled hardware as well) in the examples provided above and are not contemplated by any disclosure or work in the art.

The present invention may be implemented with a variety of cryptographic protocols to increase both confidence and security in the underlying system. A predetermined key is described as a set of masks: a plurality of mask sets. These masks may include primary, convolution and message delimiters but may extend into additional domains. In previous disclosures, the functionality of these masks is defined solely for mapping. Public and private keys may be used as key pairs to further increase the unlikeliness that a key may be compromised. Examples of public key cryptosystems may be found in the following U.S. Patents Nos: 4,200,770; 4,218,582; 4,405,829; and 4,424,414, which examples are incorporated herein by reference. Prior to encoding, the masks described above are generated by a cryptographically secure random generation process. Mask sets may be limited only by the number of dimensions and amount of error correction or concealment sought, as has been previously disclosed.

A block cipher, such as DES, in combination with a sufficiently random seed value emulates a cryptographically secure random bit generator. These keys, or key pairs, will be saved along with information matching them to the sample stream in question in a database for use in subsequent detection or decode operation. These same cryptographic protocols may be combined with the embodiments of the present invention in administering streamed content that requires authorized keys to correctly display or play said streamed content in an unscrambled manner. As with digital watermarking, symmetric or asymmetric public key pairs may be used in a variety of

implementations. Additionally, the need for certification authorities to maintain authentic key-pairs becomes a consideration for greater security beyond symmetric key implementations, where transmission security is a concern.

Signal Processing in a Multi-watermark System (A Plurality of Streams May Be Watermarked)

FIG. 2 illustrates a system and method of implementing a multiple-watermark system. An input signal 11 (e.g., binary executable code, instruction text, or other data), is first processed by a lossy data-reduction scheme 200 (e.g., down-sampling, bit-rate reduction, or compression method) to produce a data-reduced signal 40. Data-reduced signal 40 is then embedded with a watermark (process step 300) to generate a watermarked, data-reduced signal 50, while a copy of the unmarked, data-reduced signal 40 is saved.

The saved, unwatermarked data-reduced signal (signal 40) is subtracted from the original input signal 11, yielding a remainder signal 60 composed only of the data that was lost during the data-reduction. A second watermark is then applied (process step 301) to remainder signal 60 to generate a watermarked remainder signal 70. Finally, the watermarked remainder 70 and the watermarked, data-reduced signal 50 are added to form an output signal 80, which is the final, full-bandwidth, output signal.

The two watermarking techniques (process steps 300 and 301) may be identical (i.e., be functionally the same), or they may be different.

To decode the signal, a specific watermark is targeted. Duplicating the data-reduction processes that created the watermark in some cases can be used to recover the signal that was watermarked. Depending upon the data-reduction method, it may or may not be necessary to duplicate the data-reduction process in order to read a watermark embedded in a remainder signal. Because of the data-reduction, the decoding search can occur much faster than it would in a full-bandwidth signal. Detection speed of the remainder watermark remains the same as if there were no other watermark present.

FIG. 4 illustrates a functional block diagram for one means of decoding the output signal generated by the system illustrated in FIG. 2. A signal to be analyzed 80 (e.g., the same output from FIG. 2) is processed by a data-reduction scheme 200. Data reduced signal 41 can then be decoded to remove the message that was watermarked in the original data reduced signal. Further, data reduced signal 41 can be subtracted from signal to be analyzed 80 to form a differential signal 61 which can then be decoded to remove the message that was watermarked in the original remainder signal. A decoder may only be able to perform one of the two decodings. Differential access and/or different keys may be necessary for each decoding.

Additionally, the watermarking described in connection with this embodiment above may be done with a plurality of predetermined keys or key pairs associated with a single watermark "message bit," code object, or text.

Signal Processing in a Single Watermark System

FIG. 3 illustrates a system and method of implementing a single watermark system. The process and system contemplated here is identical to process described in connection to FIG. 2, above, except that no watermark is embedded in the remainder signal. Hence, the watermarked, data-reduced signal 50 is added directly to the remainder signal 60 to generate an output signal 90. Additionally, the watermarking described in connection with this embodiment above may be done with a plurality of predetermined keys or key pairs associated with a single watermark "message bit," code object, or text.

In either process, an external key can be used to control the insertion location of either watermark. In a copy-control system, a key is not generally used, whereas in a forensic system, a key must be used. The key can also control the parameters of the data-reduction scheme. The dual scheme can allow a combination of copy-control and forensic watermarks in the same signal. A significant feature is that the copy-control watermark can be read and rewritten without affecting the forensic mark or compromising its security.

FIG. 5 illustrates a functional block diagram for one means of decoding the output signal generated by the system illustrated in FIG. 3. A signal to be analyzed 90 (e.g., the same output from FIG. 3) is processed by a data-reduction scheme 200. Data reduced signal 41 can then be decoded to remove the message that was watermarked in the original data reduced signal.

Signal Processing in a Multi-scrambler System (A Plurality of Streams May Be Scrambled)

FIG. 6 illustrates a system and method of implementing a multi-scrambler system. An input signal 12 (e.g., binary executable code, instruction text, or other data), is first processed by a lossy data-reduction scheme 400 (e.g., down-sampling, bit-rate reduction, or compression method) to produce a data-reduced signal 45. Data-reduced signal 45 is then scrambled using a first scrambling technique (process step 500) to generate a scrambled, data-reduced signal 55, while a copy of the unscrambled, data-reduced signal 45 is saved.

The saved, unscrambled data-reduced signal (signal 45) is subtracted from the original input signal 12, yielding a remainder signal 65 composed only of the data that was lost during the data-reduction. A second scrambling technique is then applied (process step 501) to remainder signal 65 to generate a scrambled remainder signal 75. Finally, the scrambled remainder signal 75 and the scrambled data-reduced signal 55 are added to form an output signal 85, which is the final, full-bandwidth, output signal.

The two scrambling techniques (process steps 500 and 501) may be identical (i.e., be functionally the same), or they may be different.

Additionally the scrambling described in connection with this embodiment may be done with a plurality of predetermined keys or key pairs associated with a single scrambling operation containing only a "message bit," code object, or text.

To decode the signal, unscrambling follows the exact pattern of the scrambling process except that the inverse of the scrambling transfer function is applied to each portion of the data, thus returning it to its pre-scrambled state.

FIG. 8 illustrates a functional block diagram for one means of decoding the output signal generated by the system illustrated in FIG. 6. A signal to be analyzed 85 (e.g., the same output from FIG. 6) is processed by a data-reduction scheme 200. Data reduced signal 46 can be subtracted from signal to be analyzed 85 to form a differential signal 66, which signal can then be descrambled in process 551 using the inverse transfer function of the process that scrambled the original remainder signal (e.g., the inverse of scrambling process 501). Descrambling process 551 generates an descrambled signal 76. Data reduced signal 46 may further be descrambled in process 550 using the inverse transfer function of the process that scrambled the original data reduced signal (e.g., the inverse of scrambling process 500). Descrambling process 550 generates an descrambled signal 56, which may then be added to descrambled signal 76 to form an output signal 98.

Signal Processing in a Single Scrambling Operation

FIG. 7 illustrates a system and method of implementing a single scrambling system. The process and system contemplated here is identical to process described in connection to FIG. 6, above, except that no scrambling is applied to the remainder signal. Hence, the scrambled data-reduced signal 55 is added directly to the remainder signal 65 to generate an output signal 95.

Additionally the scrambling described in connection with this embodiment may be done with a plurality of predetermined keys or key pairs associated with a single scrambling operation containing only a "message bit," code object, or text.

FIG. 9 illustrates a functional block diagram for one means of decoding the output signal generated by the system illustrated in FIG. 7. A signal to be analyzed 95 (e.g., the same output from FIG. 7) is processed by a data-reduction scheme 200. Data reduced signal 46 can be subtracted from signal to be analyzed 95 to form a differential

signal 66. Data reduced signal 46 may further be descrambled in process 550 using the inverse transfer function of the process that scrambled the original data reduced signal (e.g., the inverse of scrambling process 500). Descrambling process 550 generates an descrambled signal 56, which may then be added to differential signal 66 to form an output signal 99.

Sample Embodiment: Combinations

Another embodiment may combine both watermarking and scrambling with data reduction. Speed, performance and computing power may influence the selection of which techniques are to be used. Decisions between data reduction schemes ultimately must be measured against the types of keys or key pairs to use, the way any pseudo random or random number generation is done (chaotic, quantum or other means), and the amount of scrambling or watermarking that is necessary given the needs of the system.

It is quite possible that some derived systems would yield a fairly large decision tree, but the present invention offers many benefits to applications in security that are not disclosed in the art.

Conclusions

Data signals fall into two categories: those which can undergo lossy data reduction and remain functional and those which cannot. Audio, images, video are examples of the first. Computer code is an example of the second. In general, all members of the first category contain an aesthetic component, which may be reduced and/or manipulated during a data reduction, in addition to a functional component which serves to identify the signal. For example, an audio signal may have noise added while still remaining recognizably identifiable as a particular song. However, beyond a certain point, the addition of more noise will cause the signal to become unidentifiable, thus impairing the functional character of the signal. In the absence of

an aesthetic component, as with computer code where every bit of data is necessary, lossy compression that retains functionality is not possible.

Signals in the first category are the only candidates for watermarking. A watermark is a distortion of the aesthetic component, generally of an imperceptible nature. This category will gain speed benefits during the watermark decoding process when a lossy data-reduction method is used as described above.

Scrambling, on the other hand, may be applied to any signal, regardless of its aesthetic component, since it allows for perfect reconstruction of the original signal. A scrambling system can be made more secure by applying a data reduction method prior to scrambling, even if this data reduction makes the intermediate signals non-functional, as is the case with signals in category two.

Data reduction can make both watermarking and scrambling more secure. Data reduction can also speed the decoding process for watermarks. Finally, data reduction can allow natural channelization of watermarks for different purposes.

While the invention has been particularly shown and described in the foregoing detailed description, it will be understood by those skilled in the art that various other changes in form and detail may be made without departing from the spirit and scope of the invention.

WHAT IS CLAIMED IS:

1. A method of securing a data signal comprising:
 - applying a data reduction technique to reduce the data signal into a reduced data signal;
 - subtracting said reduced data signal from the data signal to produce a remainder signal;
 - embedding a first watermark into said reduced data signal to produce a watermarked, reduced data signal;
 - embedding a second watermark into said remainder signal to produce a watermarked remainder signal; and
 - adding said watermarked, reduced data signal to said watermarked remainder signal to produce an output signal.
2. The method of claim 1 wherein the step of subtracting is comprised of
 - storing a copy of the data signal; and
 - subtracting said reduced data signal from the copy of the data signal to produce a remainder signal.
3. The method of claim 1, wherein at least one of the watermarks is embedded using at least one key.
4. The method of claim 1, wherein at least one of the watermarks is embedded using a key pair.
5. The method of claim 4, wherein one key of the key pair is publicly available while the other key of the key pair is secret.
6. A method of protecting a data signal comprising:
 - applying a data reduction technique to reduce the data signal into a reduced data signal;
 - subtracting said reduced data signal from the data signal to produce a remainder signal;
 - embedding a first watermark into said reduced data signal to produce a watermarked, reduced data signal; and

adding said watermarked, reduced data signal to said remainder signal to produce an output signal.

7. The method of claim 6 wherein the step of adding said watermarked, reduced data signal to said remainder signal comprises:
 - embedding a second watermark into said remainder signal to produce a watermarked remainder signal; and
 - adding said watermarked, reduced data signal to said watermarked remainder signal to produce an output signal.
8. The method of claim 7, wherein at least one of the watermarks is embedded using at least one key.
9. The method of claim 7, wherein at least one of the watermarks is embedded using a key pair.
10. The method of claim 9, wherein one key of the key pair is publicly available while the other key of the key pair is secret.
11. A method of protecting a data signal:
 - applying a data reduction technique to reduce the data signal into a reduced data signal;
 - subtracting said reduced data signal from the data signal to produce a remainder signal;
 - using a first scrambling technique to scramble said reduced data signal to produce a scrambled, reduced data signal;
 - using a second scrambling technique to scramble said remainder signal to produce a scrambled remainder signal; and
 - adding said scrambled, reduced data signal to said scrambled remainder signal to produce an output signal.
12. The method of claim 11 wherein said first and second scrambling techniques are identical.

13. A method of securing a data signal comprising:
 - applying a data reduction technique to reduce the data signal into a reduced data signal;
 - subtracting said reduced data signal from the data signal to produce a remainder signal;
 - using a first cryptographic technique to encrypt the reduced data signal to produce an encrypted, reduced data signal;
 - using a second cryptographic technique to encrypt the remainder signal to produce an encrypted remainder signal; and
 - adding said encrypted, reduced data signal to said encrypted remainder signal to produce an output signal.
14. The method of claim 13 wherein said first and second cryptographic techniques are identical.
15. The method of claim 13 wherein at least one of said first and second cryptographic techniques is a watermarking technique.
16. The method of claim 15, wherein at least one of the watermarks is embedded using at least one key.
17. The method of claim 15, wherein at least one of the watermarks is embedded using a key pair.
18. The method of claim 13 wherein at least one of said first and second cryptographic techniques is a scrambling technique.
19. The method of claim 13 wherein one of said first and second cryptographic techniques is a watermarking technique and the other is a scrambling technique.
20. The method of claim 13 wherein said first and second cryptographic techniques are identical.
21. A system for securing a data signal comprising:
 - means to apply a data reduction technique to reduce the data signal into a reduced data signal;

means to subtract said reduced data signal from the data signal to produce a remainder signal;

means to apply a first cryptographic technique to encrypt the reduced data signal to produce an encrypted, reduced data signal;

means to apply a second cryptographic technique to encrypt the remainder signal to produce an encrypted remainder signal; and

means to add said encrypted, reduced data signal to said encrypted remainder signal to produce an output signal.

22. The system of claim 21 wherein said first and second cryptographic techniques are identical.
23. The system of claim 21 wherein at least one of said means to apply a first and second cryptographic technique utilizes a watermarking technique.
24. The system of claim 21 wherein at least one of said means to apply a first and second cryptographic technique utilizes a scrambling technique.
25. The system of claim 13 wherein said means to apply a first cryptographic technique is a means to apply a watermarking technique and said means to apply a second cryptographic technique is a means to apply a scrambling technique.

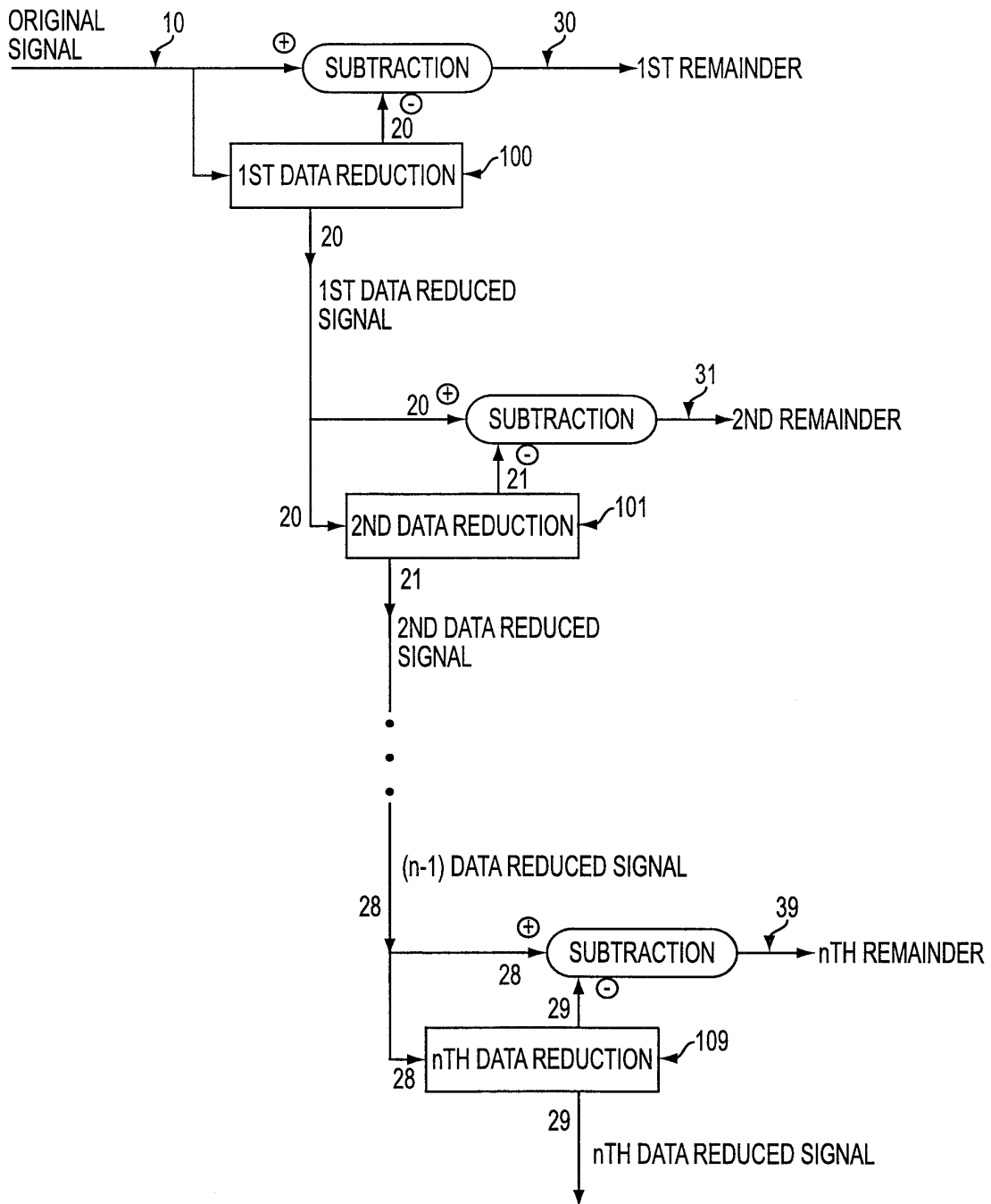

FIG. 1

SUBSTITUTE SHEET (RULE 26)

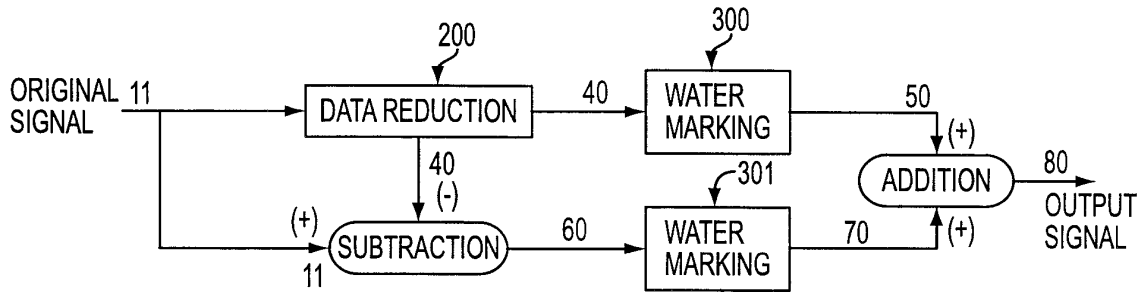

FIG. 2

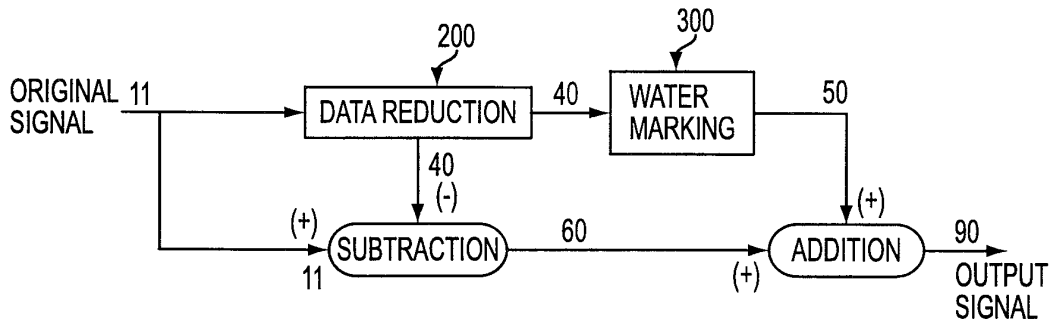

FIG. 3

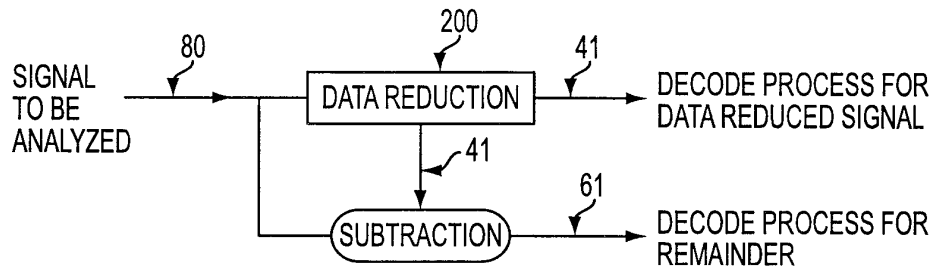

FIG. 4

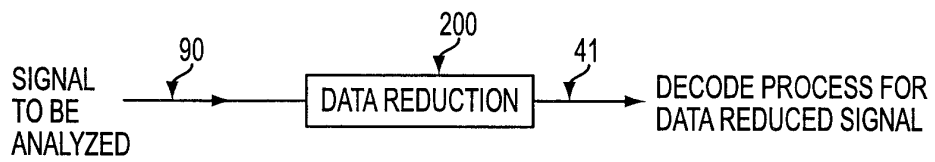

FIG. 5

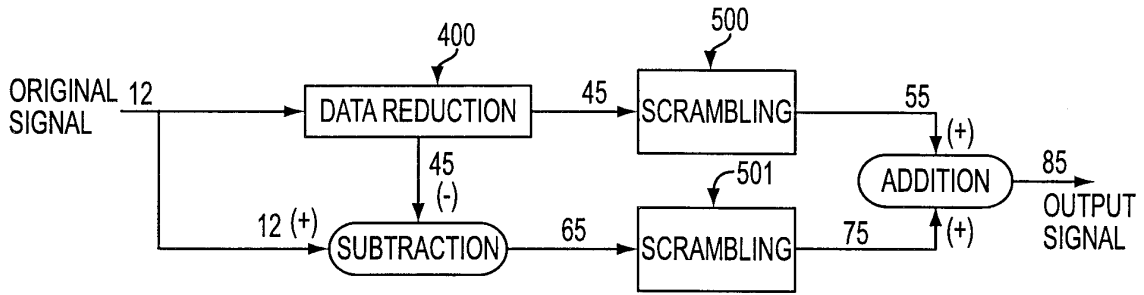

FIG. 6

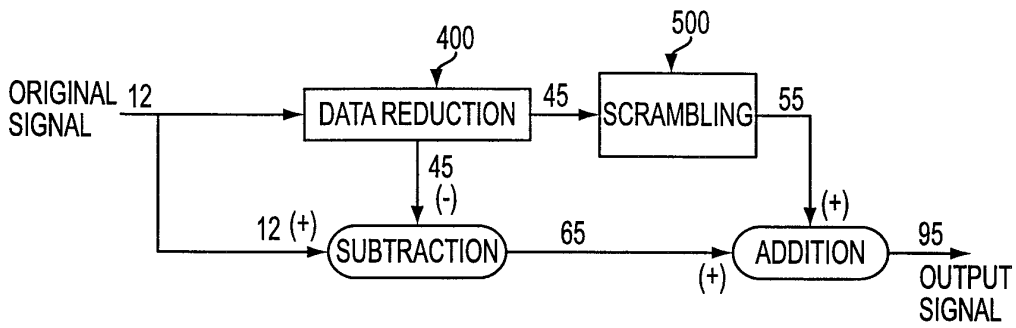

FIG. 7

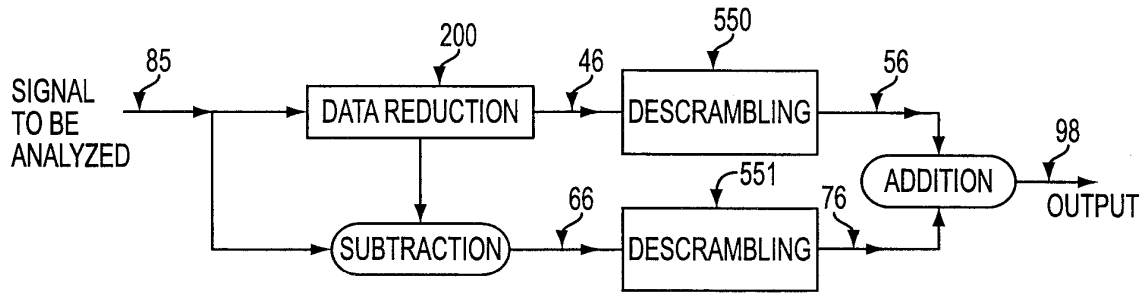

FIG. 8

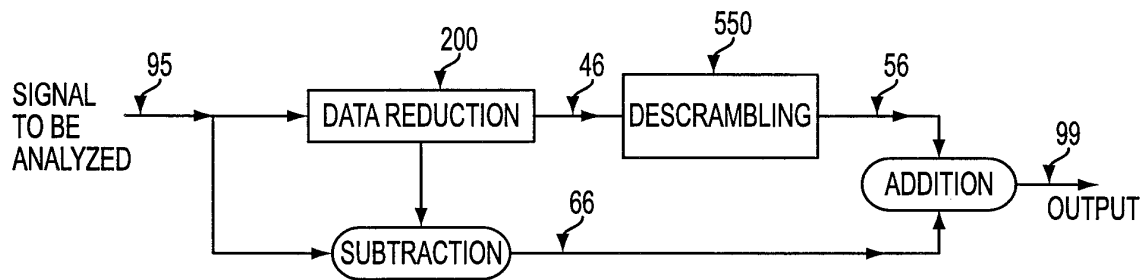
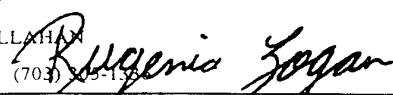

FIG. 9

INTERNATIONAL SEARCH REPORT

International application No.
PCT/US00/06522

A. CLASSIFICATION OF SUBJECT MATTER IPC(7) : HO4N 7/167 US CL : 713/176 According to International Patent Classification (IPC) or to both national classification and IPC		
B. FIELDS SEARCHED Minimum documentation searched (classification system followed by classification symbols) U.S. : 380/200,206,207,237,238; 705/54; 704/216-218, 226-228, 500, 501, 503,504; 713/176; 360/49; 348/461, 462 Documentation searched other than minimum documentation to the extent that such documents are included in the fields searched Watermark Digest: Art Unit 2767 Electronic data base consulted during the international search (name of data base and, where practicable, search terms used) IEEE, EAST, Internet, Dialog		
C. DOCUMENTS CONSIDERED TO BE RELEVANT		
Category*	Citation of document, with indication, where appropriate, of the relevant passages	Relevant to claim No.
X,E	US 6,061,793 A [TEWFIK et al.] 09 MAY 2000, Entire Document	1-25
X	US 5,809,139 A [GIROD et al.] 15 SEPTMBER 1998, Entire Document	1-25
X	US 5,848,155 A [COX] 08 DECEMBER 1998, Entire Document	1-25
A,P	US 5,889,868 A [MOSKOWITZ et al.] 30 MARCH 1999, Entire Document	1-25
A,P	US 5,915,027 A [COX et al.] 22 JUNE 1999, Entire Document	1-25
A,P	US 5,940,134 A [WIRTZ] 17 AUGUST 1999, Entire Document	1-25
<input checked="" type="checkbox"/> Further documents are listed in the continuation of Box C. <input type="checkbox"/> See patent family annex.		
* Special categories of cited documents: *A* document defining the general state of the art which is not considered to be of particular relevance *E* earlier document published on or after the international filing date *L* document which may throw doubts on priority claim(s) or which is cited to establish the publication date of another citation or other special reason (as specified) *O* document referring to an oral disclosure, use, exhibition or other means *P* document published prior to the international filing date but later than the priority date claimed *T* later document published after the international filing date or priority date and not in conflict with the application but cited to understand the principle or theory underlying the invention *X* document of particular relevance, the claimed invention cannot be considered novel or cannot be considered to involve an inventive step when the document is taken alone *Y* document of particular relevance, the claimed invention cannot be considered to involve an inventive step when the document is combined with one or more other such documents, such combination being obvious to a person skilled in the art *&* document member of the same patent family		
Date of the actual completion of the international search 30 JUNE 2000		Date of mailing of the international search report 18 AUG 2000
Name and mailing address of the ISA/US Commissioner of Patents and Trademarks Box PCT Washington, D.C. 20231 Facsimile No. (703) 305-3230		Authorized officer PAUL E. CALLAHAN Telephone No. (703) 305-1355 

INTERNATIONAL SEARCH REPORT

International application No.
PCT/US00/06522

C (Continuation). DOCUMENTS CONSIDERED TO BE RELEVANT		
Category*	Citation of document, with indication, where appropriate, of the relevant passages	Relevant to claim No.
A,P	US 5,991,426 A [COX et al.] 23 NOVEMBER 1999, Entire Document	1-25
A,E	US 6,069,914 A [COX] 30 MAY 2000, Entire Document	1-25
A,P	US 5,943,422 A [VAN WIE et al.] 24 AUGUST 1999, Entire Document	1-25

Form PCT-ISA/210 (continuation of second sheet) (July 1998)*

PCT

WORLD INTELLECTUAL PROPERTY ORGANIZATION
International Bureau



INTERNATIONAL APPLICATION PUBLISHED UNDER THE PATENT COOPERATION TREATY (PCT)

<p>(51) International Patent Classification ⁶ : H04L</p>	<p>A2</p>	<p>(11) International Publication Number: WO 96/42151 (43) International Publication Date: 27 December 1996 (27.12.96)</p>
<p>(21) International Application Number: PCT/US96/10257 (22) International Filing Date: 7 June 1996 (07.06.96) (30) Priority Data: 08/489,172 9 June 1995 (09.06.95) US (71) Applicant: THE DICE COMPANY [US/US]; P.O. Box 60471, Palo Alto, CA 94306-0471 (US). (72) Inventors: COOPERMAN, Marc, S.; 2929 Ramona, Palo Alto, CA 94306 (US). MOSKOWITZ, Scott, A.; Townhouse 4, 20191 East Country Club Drive, North Miami Beach, FL 33180 (US). (74) Agents: ALTMILLER, John, C. et al.; Kenyon & Kenyon, 1025 Connecticut Avenue, N.W., Washington, DC 20036 (US).</p>		<p>(81) Designated States: CA, CN, FI, JP, KR, SG, European patent (AT, BE, CH, DE, DK, ES, FI, FR, GB, GR, IE, IT, LU, MC, NL, PT, SE). Published <i>Without international search report and to be republished upon receipt of that report.</i></p>
<p>(54) Title: STEGANOGRAPHIC METHOD AND DEVICE (57) Abstract An apparatus and method for encoding and decoding additional information into a stream of digitized samples in an integral manner. The information is encoded using special keys. The information is contained in the samples, not prepended or appended to the sample stream. The method makes it extremely difficult to find the information in the samples if the proper keys are not possessed by the decoder. The method does not cause a significant degradation to the sample stream. The method is used to establish ownership of copyrighted digital multimedia content and provide a disincentive to piracy of such material.</p>		

FOR THE PURPOSES OF INFORMATION ONLY

Codes used to identify States party to the PCT on the front pages of pamphlets publishing international applications under the PCT.

AM	Armenia	GB	United Kingdom	MW	Malawi
AT	Austria	GE	Georgia	MX	Mexico
AU	Australia	GN	Guinea	NE	Niger
BB	Barbados	GR	Greece	NL	Netherlands
BE	Belgium	HU	Hungary	NO	Norway
BF	Burkina Faso	IE	Ireland	NZ	New Zealand
BG	Bulgaria	IT	Italy	PL	Poland
BJ	Benin	JP	Japan	PT	Portugal
BR	Brazil	KE	Kenya	RO	Romania
BY	Belarus	KG	Kyrgyzstan	RU	Russian Federation
CA	Canada	KP	Democratic People's Republic of Korea	SD	Sudan
CF	Central African Republic	KR	Republic of Korea	SE	Sweden
CG	Congo	KZ	Kazakhstan	SG	Singapore
CH	Switzerland	LI	Liechtenstein	SI	Slovenia
CI	Côte d'Ivoire	LK	Sri Lanka	SK	Slovakia
CM	Cameroon	LR	Liberia	SN	Senegal
CN	China	LT	Lithuania	SZ	Swaziland
CS	Czechoslovakia	LU	Luxembourg	TD	Chad
CZ	Czech Republic	LV	Latvia	TG	Togo
DE	Germany	MC	Monaco	TJ	Tajikistan
DK	Denmark	MD	Republic of Moldova	TT	Trinidad and Tobago
EE	Estonia	MG	Madagascar	UA	Ukraine
ES	Spain	ML	Mali	UG	Uganda
FI	Finland	MN	Mongolia	US	United States of America
FR	France	MR	Mauritania	UZ	Uzbekistan
GA	Gabon			VN	Viet Nam

STEGANOGRAPHIC METHOD AND DEVICE

Definitions

5 Several terms of art appear frequently in the following. For ease of reference they are defined here as follows:

“Content” refers to multimedia content. This term encompasses the various types of information to be processed in a multimedia entertainment system. Content
10 specifically refers to digitized audio, video or still images in the context of this discussion. This information may be contained within files on a multimedia computer system, the files having a particular format specific to the modality of the content (sound, images, moving pictures) or the type of systems, computer or otherwise, used to process the content.

15

“Digitized” refers to content composed of discrete digital samples of an otherwise analog media, which approximate that media inside a computer or other digital device. For instance, the sound of music occurs naturally, and is experienced by humans as an analog (continuous) sound wave. The sound can be digitized into a
20 stream of discrete samples, or numbers, each of which represents an approximate

value of the amplitude of the real analog wave at a particular instant in time. These samples can be stored in files in a computer and then used to recreate the original sound wave to a high degree of accuracy.

In general, content entering a digital system is digitized by Analog to Digital
5 converters (A/D) and analog media are recreated by the digital system using a
Digital to Analog (D/A) converter. In the context of this discussion content is
always digitized content.

“Cryptography” is a field covering numerous techniques for scrambling information
10 conveying messages so that when the message is conveyed between the sender and
receiver an unintended party who intercepts this message cannot read it, or extract
useful information from it.

A “Public Key Cryptosystem” is a particular cryptographic system where all parties
15 possess pairs of keys for encryption and decryption. Parties to this type of system
freely distribute their public keys, which other may use to encrypt messages to the
owner of the public key. Such messages are decrypted by the receiver with the
private key. Private keys are never distributed. A message encrypted with a public
key can only be decrypted with the corresponding private key, and vice versa. A
20 message encrypted with a private key is said to have been signed by the owner of
that key. Anyone in possession of the public key may decrypt the message and
know that it was encrypted, and thus signed, by the owner of the public key, since
only they possess the corresponding private key.

25 “Steganography” is a field distinguished from cryptography, but associated with it,
that covers numerous methods for hiding an informational message within some
other medium, perhaps another unrelated message, in such a manner that an
unintended party who intercepts the medium carrying the hidden message does not
know it contains this hidden message and therefore does not obtain the information
30 in the hidden message. In other words, steganography seeks to hide messages in
plain view.

Background of the Invention

5 In the current environment of computer networks and the proliferation of digital or digitized multimedia content which may be distributed over such networks, a key issue is copyright protection. Copyright protection is the ability to prevent or deter the proliferation of unauthorized copies of copyrighted works. It provides a reasonable guarantee that the author of a copyrighted work will be paid for each copy of that work.

10

A fundamental problem in the digital world, as opposed to the world of physical media, is that a unlimited number of perfect copies may be made from any piece of digital or digitized content. A perfect copy means that if the original is comprised of a given stream of numbers, then the copy matches the original, exactly, for each number in the stream. Thus, there is no degradation of the original signal during the copy operation. In an analog copy, random noise is always introduced, degrading the copied signal.

15

The act of making unlicensed copies of some content, digital or analog, whether audio, video, software or other, is generally known as *piracy*. Piracy has been committed for the purpose of either profit from the sale of such unlicensed copies, or to procure for the "pirate" a copy of the content for personal use without having paid for it.

20

25 The problem of piracy has been made much worse for any type of content by the digitization of content. Once content enters the digital domain, an unlimited number of copies may be made without any degradation, if a pirate finds a way to break whatever protection scheme was established to guard against such abuses, if any. In the analog world, there is generally a degradation in the content (signal) with each successive copy, imposing a sort of natural limit on volume of piracy.

30

To date, three general types of schemes have been implemented in an attempt to protect copyrights.

- 1) Encryption
- 5 2) Copy Protection
- 3) Content Extensions

Copy Protection and Content Extensions generally apply in the digital world only, while a scheme related to Encryption, commonly known as scrambling, may be applied to an analog signal. This is typical in analog cable systems.

Encryption scrambles the content. Before the content is made ready for delivery, whether on floppy disk, or over a network, it must be encrypted, or scrambled. Once the content has been encrypted, it cannot be used until it is decrypted, or unscrambled. Encrypted audio data might sound like incomprehensible screeching, while an encrypted picture or video might appear as random patterns on a screen. The principle of encryption is that you are free to make as many copies as you want, but you can't read anything that makes sense until you use a special key to decrypt, and you can only obtain the key by paying for the content.

Encryption has two problems, however. 1) Pirates have historically found ways to crack encryption, in effect, obtaining the key without having paid for it; and 2) Once a single legitimate copy of some content has been decrypted, a pirate is now free to make unlimited copies of the decrypted copy. In effect, in order to sell an unlimited quantity of an encrypted piece of software, the pirate could simply buy one copy, which they are entitled to decrypt.

Copy Protection includes various methods by which a software engineer can write the software in a clever manner to determine if it has been copied, and if so to deactivate itself. Also included are undocumented changes to the storage format of the content. Copy protection was generally abandoned by the software industry,

since pirates were generally just as clever as the software engineers and figured out ways to modify their software and deactivate the protection. The cost of developing such protection was not justified considering the level of piracy which occurred despite the copy protection.

5

Content Extension refers to any system which attaches some extra information to the original content which indicates whether or not a copy may be made. A software or hardware system must be specifically built around this scheme to recognize the additional information and interpret it in an appropriate manner. An example of such a system is the Serial Copyright Management System embedded in Digital Audio Tape (DAT) hardware. Under this system, additional information is stored on the disc immediately preceding each track of audio content which indicates whether or not it can be copied. The hardware reads this information and uses it accordingly.

15

A fundamental problem with Encryption and Content Extension is the "rogue engineer". An employee who helped design such a system or an individual with the knowledge and means to analyze such a system can modify it to ignore the copyright information altogether, and make unlicensed copies of the content. Cable piracy is quite common, aided by illicit decoder devices built by those who understand the technical details of the cable encryption system. Although the cable systems in question were actually based on analog RF signals, the same principle applies to digital systems.

25 The practical considerations of weak encryption schemes and rogue engineers have served to limit the faith which may be put in such copyright protection schemes. The invention disclosed herein serves to address these problems with conventional systems for digital distribution. It provides a way to enforce copyright online. The invention draws on techniques from two fields, cryptography, the art of scrambling messages so that only the intended recipient may read them, and steganography, a term applied to various techniques for obscuring messages so that only the intended

30

parties to a message even know that a message has been sent, thus it is termed herein as a stega-cipher. The stega-cipher is so named because it uses the steganographic technique of hiding a message in multimedia content, in combination with multiple keys, a concept originating in cryptography. However, instead of
5 using the keys to encrypt the content, the stega-cipher uses these keys to locate the hidden message within the content. The message itself is encrypted which serves to further protect the message, verify the validity of the message, and redistribute the information in a random manner so that anyone attempting to locate the message without the keys cannot rely on pre-supposed knowledge of the message contents
10 as a help in locating it.

Summary of the Invention

The invention disclosed herein combines two techniques, steganography - obscuring
15 information that is otherwise in plain sight, and cryptography - scrambling information that must be sent over unsecured means, in a manner such that only the intended recipient may successfully unscramble it. The net effect of this system is to specifically watermark a piece of content so that if it is copied, it is possible to determine who owned the original from which the copies were made, and hence
20 determine responsibility for the copies. It is also a feature of the system to uniquely identify the content to which it is applied.

For a comprehensive discussion of cryptography, its theory, applications and specific algorithms, see APPLIED CRYPTOGRAPHY, by Bruce Schneier, which is
25 herein incorporated by reference at pages 66-68, 387-392.

Steganography is discussed briefly in THE CODE BREAKERS by David Kahn, which is herein incorporated by reference at pages xiii, 81-83, 522-526, and 873. An example application, Stego by Romana Machado, is also available for the Apple
30 Macintosh. Stego can be found at the internet uniform resource locator "<http://sumex-aim.stanford.edu/info-mac/cmp/stego10a2.hqx>". This application demonstrates a simple

steganographic technique to encode a text message into a graphical image without significantly distorting the image.

5 The invention improves upon the prior art by providing a manner for protecting copyright in the digital domain, which neither steganography or cryptography does. It improves specifically on steganography by making use of special keys which dictate exactly where within a larger chunk of content a message is to be hidden, and makes the task of extracting such a message without the proper key the equivalent of looking for a needle in a haystack.

10 The information encoded by the Stega-Cipher process serves as a watermark which identifies individual copies of content legally licensed to specific parties. It is integral with the content. It cannot be removed by omission in a transmission. It does not add any overhead to signal transmission or storage. It does allow the content to be stored to and used with traditional offline analog and digital media, without modification or significant signal degradation. These aspects of the stega-cipher all represent improvements to the art. That is, its forces would - be pirates to damage the content in order to guarantee the disabling of the watermark.

20 The invention described herein is used for protecting and enforcing copyrights in the digital or on-line domain, where there are no physical limitations on copying copyrighted content.

25 The invention uniquely identifies every copy of multimedia content made using the invention, composed of digitized samples whether compressed or uncompressed, including but not limited to still digital images, digital audio, and digital video.

30 The invention is for use in meterware or pay-by-use systems where an online user incurs a charge each time they access a particular piece of content, or uses a software title.

The invention is for use as a general improvement to cryptographic techniques to increase the complexity of cryptanalysis on a given cipher.

5 It is considered that the method and steps of the present invention will be modified to account for the effects of loss compression schemes on the samples and particularly includes modification to handle MPEG compressed audio and video.

10 It is considered that statistical data spreading and recovery techniques, error coding or spread spectrum processing techniques might be applied in the invention to handle the effects of loss compression, or counter the effects of a randomization attack.

15 It is considered that the apparatus described might be further specialized and optimized in hardware by replacing general purpose data buses and CPU or DSP driven operations with hardwired circuitry, incorporated in one or more special purpose ICs.

20 It is considered that the apparatus will be modeled and implemented in software on general purpose computer platforms.

It is considered that stega-cipher hardware could be embedded in a consumer electronics device and used to not only identify content and copyright, but to enable use of that content.

25 **Detailed Description**

I. Digital Copyright Stega-Cipher Protocol and the Decode/Encode Program

30 The purpose of the program described here is to watermark digital multimedia content for distribution to consumers through online services in such a way as to meet the following criteria

Given a unique piece of multimedia content, composed of digitized samples, it is desirable to:

- 5 1) Uniquely identify this particular piece of content from others in a manner which is secure and undeniable (e.g. to know whether a digital audio recording is "My Way" by Frank Sinatra, or "Stairway to Heaven", by Led Zeppelin), and in a manner such that this identification can be performed automatically by an electronic device or mechanism.
 - 10 2) Uniquely identify the copyright owner of the content, and the terms under which it may be distributed in general, in a manner which is secure and undeniable.
 - 15 3) At such time as is necessary, additionally, uniquely identify in a secure and undeniable manner the licensed publisher who received a particular copy of the content, and the terms under which they may redistribute or resell it.
 - 20 4) At such time as is necessary, additionally, uniquely identify in a secure and undeniable manner, the licensed subscriber who received a particular copy of the content from the publisher described in item 3.
- 20 The program described in more detail below combines the techniques of cryptography and steganography to hide a securely encrypted digital copyright certificate which contains information satisfying the criteria listed above, in such a manner as to be integral with the content, like a watermark on paper, so that
- 25 possession of the content dictates possession of the watermark information. In addition, the watermark cannot be "found" or successfully decoded, without possession of the correct "masks" or keys, available only to those legitimately authorized, namely, those parties to a commercial transaction involving the sale of a copy of the content. Finally, the ability to distribute such watermarked content in a
- 30 system which implements the watermark scheme is denied without a successfully decoded watermark. Because well known and tested cryptographic techniques are

used to protect the certificate itself, these certificates are virtually impossible to forge. Finally, the watermark cannot be erased without significantly damaging the content.

5 The basic program represents a key part of the invention itself. This program is then used as the method by which copyright information is to be associated in an integral manner with the content. This is a concept absent from copy protection, encryption and content extension schemes. The copyright information itself can be made undeniable and unforgeable using cryptographic techniques, so that through it an
10 audit trail of ownership may be established for each copy of a given piece of content, thus customizing each copy to a particular owner, in a way that can be used to identify the owner.

The value of the stega-cipher is that it provides a way to watermark the content in a
15 way that changes it slightly, but does not impact human perception significantly. And, furthermore, that it is made difficult to defeat since one must know exactly where the information resides to extract it for analysis and use in forgery attempts, or to remove it without overly degrading the signal. And, to try to forge copyright information one must first be able to analyze the encrypted copyright information,
20 and in order to do that, one must be able to find it, which requires masks.

II. Example Embodiment of General Processing

Digital audio data is represented by a series of samples in 1 dimension,
25

$$\{S_1, S_2, S_3 \dots S_n\}$$

This series is also referred to as a sample stream. The sample stream approximates an analog waveform of sound amplitude over time. Each sample represents an
30 estimate of the wave amplitude at the instant of time the sample is recorded. For monaural audio, there is one such sample stream. Stereo audio is comprised of two

sample streams, one representing the right channel, and the other representing the left. Each stream is used to drive a corresponding speaker to reproduce the stereo sound.

- 5 What is referred to as CD quality audio is characterized by 16 bit (2 byte) stereo samples, recorded at 44.1 Khz, or 44,100 samples per second in each channel. The dynamic range of sound reproduction is directly proportional to the number of bits per sample. Some lower quality recordings are done at 8 bits. A CD audio recording can be stored using any scheme for containing the 2 sample streams in
 10 their entirety. When these streams are played back at the same frequency they were recorded at, the sound recorded is reproduced to a high degree of accuracy.

The sample stream is processed in order from first sample to last. For the purpose of the invention disclosed, the stream is separated into sample windows, each of
 15 which has a fixed number of consecutive samples from the stream, and where windows do not overlap in the sample stream. Windows may be contiguous in the sample stream. In this discussion assume each window contains 128 samples, and that windows are contiguous. So, the windows within the stream look like

$$20 \quad \{ [S_1, S_2, S_3 \dots S_{128}], [S_{129}, S_{130}, S_{131} \dots S_{256}], \dots [S_{n-128} \dots S_n] \}$$

where [...] denotes each window and any odd samples at the end of the stream which do not completely fill a window can be ignored, and simply passed through the system unmodified.

- 25 These windows will be used as input for the discrete Fast Fourier Transform (and its inverse) operation.

Briefly, Fourier Transform methods are based on the principle that a complex waveform, expressed as amplitude over time and represented by a sample stream, is
 30 really the sum of a number of simple waveforms, each of which oscillate at different frequencies.

By complex, it is meant that the value of the next sample is not easily predicted from the values of the last N samples or the time of the sample. By simple it is meant that the value of the sample is easily predictable from the values of the last N samples and/or the time of the sample.

5

The sum of multiple simple waves is equivalent to the complex wave. The discrete FFT and its inverse simply translate a limited amount of data from one side of this equivalence to the other, between the complex waveform and the sum of simple waves. The discrete FFT can be used to translate a series of samples representing amplitude over time (the complex wave, representing a digital audio recording) into the same number of samples representing total spectral energy in a given range of frequencies (the simple wave components) at a particular instant of time. This instant is the time in the middle of the original amplitude/time samples. The inverse discrete FFT translates the data in the other direction, producing the complex waveform, from its simpler parts.

10
15

Each 128 sample window will be used as an input to the discrete FFT, resulting in 128 bins representing each of 128 frequency bands, ranging from 0Hz to 22Khz (the Nyquist frequency, or $\frac{1}{2}$ the sampling rate).

20

Information can be encoded into the audio signal in the frequency domain or in the time domain. In the latter case, no FFT or inverse FFT is necessary. However, encoding in the frequency domain is recommended, since its effects are scattered over the resultant time domain samples, and not easily predicted. In addition, frequency domain encoding makes it more likely that randomization will result in noticeable artifacts in the resultant signal, and therefore makes the stega-cipher more defensible against such attacks. It is in the frequency domain that additional information will be encoded into the audio signal for the purpose of this discussion. Each frequency band in a given time slice can potentially be used to store a small portion of some additional information to be added to the signal. Since these are discrete estimates, there is some room for error which will not significantly effect

25
30

the perceived quality of the signal, reproduced after modification, by the inverse FFT operation. In effect, intentional changes, which cannot be distinguished from random variations are introduced in the frequency domain, for the purpose of storing additional information in the sample stream. These changes are minimized so as not to adversely affect the perceived quality of the reproduced audio signal, after it has been encoded with additional information in the manner described below. In addition, the location of each of these changes is made virtually impossible to predict, an innovation which distinguishes this scheme from simple steganographic techniques.

10

Note that this process differs from the Nagata, et al. patents, 4,979,210 and 5,073,925, which encode information by modulating an audio signal in amplitude/time domain. It also differs in that the modulations introduced in the Nagata process (which are at very low amplitude and frequency relative to the carrier wave as to remain inaudible) carry only copy/ don't copy information, which is easily found and circumvented by one skilled in the art. Also, there is no limitation in the stega-cipher process as to what type of information can be encoded into the signal, and there is more information storage capacity, since the encoding process is not bound by any particular frequency of modulation but rather by the number of samples available. The granularity of encoding in the stega-cipher is determined by the sample window size, with potentially 1 bit of space per sample or 128 bits per window (a secure implementation will halve this to 64 bits). In Nagata, et al. the granularity of encoding is fixed by the amplitude and frequency modulation limits required to maintain inaudibility. These limits are relatively low, and therefore make it impractical to encode more than simple copy/ don't copy information using the Nagata process.

25

III. Example Embodiment of Encoding and Decoding

5 A modification to standard steganographic technique is applied in the frequency domain described above, in order to encode additional information into the audio signal.

10 In a scheme adapted from cryptographic techniques, 2 keys are used in the actual encode and decode process. For the purposes of this invention the keys are referred to as masks. One mask, the primary, is applied to the frequency axis of FFT results, the other mask is applied to the time axis (this will be called the convolution mask). The number of bits comprising the primary mask are equal to the sample window size in samples (or the number of frequency bands computed by the FFT process), 128 in this discussion. The number of bits in the convolution mask are entirely arbitrary. This implementation will assume a time mask of 1024 bits. Generally the
15 larger the key, the more difficult it is to guess.

Prior to encoding, the primary and convolution masks described above are generated by a cryptographically secure random generation process. It is possible to use a block cipher like DES in combination with a sufficiently pseudo-random seed
20 value to emulate a cryptographically secure random bit generator. These keys will be saved along with information matching them to the sample stream in question in a database for use in decoding, should that step become necessary.

25 Prior to encoding, some additional information to be encoded into the signal is prepared and made available to the encoder, in a bit addressable manner (so that it may be read one bit at a time). If the size of the sample stream is known and the efficiency characteristics of the stega-cipher implementation are taken into account, a known limit may be imposed on the amount of this additional information.

30 The encoder captures one sample window at a time from the sample stream, in sequential, contiguous order. The encoder tracks the sequential number of each

window it acquires. The first window is 0. When the number of windows processed reaches the number of bits in the window mask, minus one, the next value of the window counter will be reset to 0.

- 5 This counter is the convolution index or phase. In the current implementation it is used as a simple index into the convolution bitmask. In anticipated developments it will be used to perform convolution operations on the convolution mask to determine which bit to use. For instance the mask might be rotated by a number corresponding to the phase, in bits to the left and XORed with the primary mask to
- 10 produce a new mask, which is then indexed by the phase. There are many possibilities for convolution.

The encoder computes the discrete FFT of the sample window.

- 15 Starting with the lowest frequency band, the encoder proceeds through each band to the highest, visiting each of the 128 frequency bands in order. At each band value, the encoder takes the bit of the primary mask corresponding to the frequency band in question, the bit of the convolution mask corresponding to the window in question, and passes these values into a boolean function. This function is designed
- 20 so that it has a near perfectly random output distribution. It will return true for approximately 50% of its input permutations, and false for the other 50%. The value returned for a given set of inputs is fixed, however, so that it will always return the same value given the same set of inputs.
- 25 If the function returns true, the current frequency band in the current window is used in the encoding process, and represents a valid piece of the additional information encoded in the signal. If the function returns false, this cell, as the frequency band in a given window is called, is ignored in the process. In this manner it is made extremely difficult to extract the encoded information from the signal
- 30 without the use of the exact masks used in the encoding process. This is one place in which the stega-cipher process departs from traditional steganographic

implementations, which offer a trivial decode opportunity if one knows the information is present. While this increases the information storage capacity of the carrier signal, it makes decoding trivial, and further degrades the signal. Note that it is possible and desirable to modify the boolean cell flag function so that it returns true < 50% of the time. In general, the fewer cells actually used in the encode, the more difficult they will be to find and the less degradation of content will be caused, provided the function is designed correctly. There is an obvious tradeoff in storage capacity for this increased security and quality.

10 The encoder proceeds in this manner until a complete copy of the additional information has been encoded in the carrier signal. It will be desirable to have the encoder encode multiple copies of the additional information continuously over the duration of the carrier signal, so that a complete instance of this information may be recovered from a smaller segment of a larger signal which has been split into
15 discontinuous pieces or otherwise edited. It is therefore desirable to minimize the size of the information to be encoded using both compact design and pre-encoding compression, thus maximizing redundant encoding, and recoverability from smaller segments. In a practical implementation of this system it is likely the information will be first compressed by a known method, and then encrypted using public-key
20 techniques, before being encoded into the carrier signal.

The encoder will also prepare the package of additional information so that it contains an easily recognizable start of message delimiter, which can be unique to each encoding and stored along with the keys, to serve as a synchronization signal
25 to a decoder. The detection of this delimiter in a decoding window signifies that the decoder can be reasonably sure it is aligned to the sample stream correctly and can proceed in a methodic window by window manner. These delimiters will require a number of bits which minimizes the probability that this bit sequence is not reproduced in a random occurrence, causing an accidental misalignment of the
30 decoder. A minimum of 256 bits is recommended. In the current implementation 1024 bits representing a start of message delimiter are used. If each sample is

random, then each bit has a 50% probably of matching the delimiter and the conditional probability of a random match would be $1/2^{1024}$. In practice, the samples are probably somewhat less than random, increasing the probability of a match somewhat.

5

The decode process uses the same masks in the same manner, only in this case the information is extracted one bit at a time from the carrier signal.

The decoder is assumed to have access to the proper masks used to encode the information originally. These masks might be present in a database, which can be indexed by a value, or values computed from the original content, in a manner insensitive to the modifications to the content caused by the stega-cipher process. So, given an arbitrary piece of content, a decoder might first process the content to generate certain key values, and then retrieve the decode masks associated with the matching key values from the database. In the case where multiple matches occur, or none are found, it is conceivable that all mask sets in the database could be tried sequentially until a valid decode is achieved, or not, indicating no information is present.

In the application of this process, it is anticipated that encoding operations may be done on a given piece of content up to 3 times, each adding new information and using new masks, over a sub-segment of the content, and that decode operations will be done infrequently. It is anticipated that should it become necessary to do a search of a large number of masks to find a valid decode, that this process can be optimized using a guessing technique based on close key matching, and that it is not a time critical application, so it will be feasible to test large numbers of potential masks for validity on a given piece of content, even if such a process takes days or weeks on powerful computers to do a comprehensive search of known mask sets.

The decode process is slightly different in the following respect. Whereas the encoding process can start at any arbitrary point in the sample stream, the decode

process does not know where the encode process began (the exact offset in samples to the start of the first window). Even though the encode process, by convention, starts with sample 0, there is no guarantee that the sample stream has not been edited since encoding, leaving a partial window at the start of the sample stream, and thus requiring the decoder to find the first complete window to start the decode. Therefore, the decode process will start at the first sample, and shift the sample window along by 1 sample, keeping the window index at 0, until it can find a valid decode delimiter encoded in the window. At this point, the decoder knows it has synchronized to the encoder, and can then proceed to process contiguous windows in a more expedient manner.

Example Calculations based on the described implementation for adding copyright certificate information to CD quality digital audio:

- 15 In a stream of samples, every 128 samples will contain, on average 64 bits of certificate related information. Digital audio is composed of 16 bit samples, at 44.1 Khz, or 44,100 samples per second. Stereo audio provides 2 streams of information at this rate, left and right, or 88,200 samples per second. That yields approximately 689 contiguous sample windows (of 128 samples) per second in which to encode information. Assume a song is 4 minutes long, or 240 seconds. This yields $240 * 689 = 165,360$ windows, which on average (50% utilization) contain 64 bits (8 bytes) each of certificate information. This in turns gives approximately 1291Kb of information storage space per 4 minute stereo song (1.2 MB). There is ample room for redundant encoding of information continuously over the length of the content.
- 20
- 25 Encoding 8 bytes for every 256 bytes represents 3.1% of the signal information. Assuming that a copyright certificate requires at most approximately 2048 bytes (2K), we can encode the same certificate in 645 distinct locations within the recording, or approximately every 37/100ths of a second.
- 30 Now to account for delimiters and synchronization information. Assuming a sync marker of 1024 bits to avoid random matches, then we could prefix each 2K

- certificate block with this 1024 bit marker. It takes 256 windows to store 2K, and under this proposed scheme, the first 16 windows are reserved for the sync marker. A decoder could search for this marker by progressively matching each of the first 16 windows (64 bits at a time) against the corresponding portion of the sync marker. The decoder could reset the match advancing through the sample stream, as soon as one window did not conform to the sync marker, and proceed in this manner until it matches 16 consecutive windows to the marker, at which point it is synchronized.
- Under this scheme, 240 windows, or 1.92K remain for storing certificate information, which is not unreasonable.

IV. Possible Problems, Attacks and Subsequent Defenses

A. Randomization

- The attacker simply randomizes the least significant bits of each data point in the transform buffer, obliterating the synchronization signal and the watermark. While this attack can remove the watermark, in the context in which stega-cipher is to be used, the problem of piracy is kept to a minimum at least equal to that afforded by traditional media, since the system will not allow an unwatermarked piece of content to be traded for profit and watermarks cannot be forged without the proper keys, which are computationally difficult to obtain by brute-force or cryptanalysis. In addition, if the encoding is managed in such a way as to maximize the level of changes to the sample stream to be just at the threshold below human perception, and the scheme is implemented to anticipate randomization attempts, it is possible to force the randomization level to exceed the level that can be perceived and create destructive artifacts in the signal, in much the same manner as a VHS cassette can be manufactured at a minimal signal level, so that a single copy results in unwatchable static.

30

B. Low Bit-Depth Bitmaps (black & white images)

These bitmaps would be too sensitive to the steganization process, resulting in unacceptable signal degradation, and so are not good candidates for the stega-cipher process. The problem may be circumvented by inflating bit-depth, although
5 this is an inefficient use of space and bandwidth.

C. Non-Integer Transforms

The FFT is used to generate spectral energy information for a given audio signal. This information is not usually in integer format. Computers use methods of
10 approximation in these cases to represent the real numbers (whole numbers plus fractional amounts). Depending on the exact value of the number to be represented slight errors, produced by rounding off the nearest real number that can be completely specified by the computer occur. This will produce some randomization in the least significant bit or bits. In other words, the same operation on the same
15 sample window might yield slightly different transform values each time. It is possible to circumvent this problem using a modification to the simple LSB steganographic technique described later. Instead of looking at the LSB, the stega-cipher can use an energy quantization technique in place of the LSB method. Some
20 variant of rounding the spectral energy values up or down, with a granularity greater than the rounding error should work, without significantly degrading the output samples.

V. A Method and Protocol For Using the Stega-Cipher

25 The apparatus described in the claims below operates on a window by window basis over the sample stream. It has no knowledge of the nature of the specific message to be encoded. It merely indexes into a bit stream, and encodes as many of those bits as possible into a given sample window, using a map determined by the given
30 masks.

30

The value of encoding information into a single window in the sample stream using such an apparatus may not be inherently apparent until one examines the manner in which such information will be used. The protocol discussed in this section details how messages which exceed the encoding capacity of a single sample window (128 samples) may be assembled from smaller pieces encoded in the individual windows and used to defend copyrights in an online situation.

An average of 64 bits can be encoded into each window, which equals only 8 bytes. Messages larger than 8 bytes can be encoded by simply dividing the messages up and encoding small portions into a string of consecutive windows in the sample stream. Since the keys determine exactly how many bits will be encoded per window, and an element of randomness is desirable, as opposed to perfect predictability, one cannot be certain exactly how many bits are encoded into each window.

The start of each message is marked by a special start of message delimiter, which, as discussed above is 1024 bits, or 128 bytes. Therefore, if precisely 8 bytes are encoded per window, the first 16 windows of any useable message in the system described here are reserved for the start of message delimiter. For the encoder, this scheme presents little challenge. It simply designates the first sample window in the stream to be window 0, and proceeds to encode the message delimiter, bit-by-bit into each consecutive window. As soon as it has processed the last bit of the SOM delimiter it continues by encoding 32 bits representing the size, in bytes of the complete message to follow. Once the 32nd and final bit of the size is encoded, the message itself is encoded into each consecutive window, one bit at a time. Some windows may contain more encoded bits than others, as dictated by the masks. As the encoder processes each window in the content it increments its window counter. It uses this counter to index into the window mask. If the number of windows required to encode a complete message is greater than the size of this mask, 256 bits in this case, or 256 windows, then it simply resets the counter after window

255, and so on, until a complete message is encoded. It can then start over, or start on a new message.

The decoder has a bigger challenge to face. The decoder is given a set of masks,
5 just like encoder. Unlike the encoder, the decoder cannot be sure that the first series
of 128 samples it receives are the window 0 start of message, encoded by the
decoder. The sample stream originally produced by an encoder may have been
edited by clipping its ends randomly or splicing pieces together. In that case, the
particular copy of the message that was clipped is unrecoverable. The decoder has
10 the start of message delimiter used to encode the message that the decoder is
looking for. In the initial state, the decoder assumes the first window it gets is
window 0. It then decodes the proper number of bits dictated by the masks it was
given. It compares these bits to the corresponding bits of the start of message
delimiter. If they match, the decoder assumes it is still aligned, increments the
15 window counter and continues. If the bits do not match, the decoder knows it is not
aligned. In this case, it shifts one more sample onto the end of the sample buffer,
discarding the first sample, and starts over. The window counter is set to 0. The
decoder searches one sample at a time for an alignment lock. The decoder proceeds
in this manner until it has decoded a complete match to the start of message
20 delimiter or it exhausts the sample stream without decoding a message. If the
decoder can match completely the start of message delimiter bit sequence, it
switches into aligned mode. The decoder will now advance through the sample
stream a full window at a time (128 samples). It proceeds until it has the 32 bits
specifying the message size. This generally won't occupy more than 1 complete
25 window. When the decoder has locked onto the start of message delimiter and
decoded the message size, it can now proceed to decode as many consecutive
additional windows as necessary until it has decoded a complete message. Once it
has decoded a complete message, the state of the decoder can be reset to un-
synchronized and the entire process can be repeated starting with the next 128
30 sample window. In this manner it is not absolutely necessary that encoding windows

be contiguous in the sample stream. The decoder is capable of handling random intervals between the end of one message and the start of another.

5 It is important to note that the circuit for encoding and decoding a sample window does not need to be aware of the nature of the message, or of any structure beyond the start of message delimiter and message size. It only needs to consider a single sample window, its own state (whether the decoder is misaligned, synchronizing, or synchronized) and what bits to encode/decode.

10 Given that the stega-cipher apparatus allows for the encoding and decoding of arbitrary messages in this manner, how can it be used to protect copyrights?

15 The most important aspect of the stega-cipher in this respect is that fact that it makes the message integral with the content, and difficult to remove. So it cannot be eliminated simply by removing certain information prepended or appended to the sample stream itself. In fact, removing an arbitrary chunk of samples will not generally defeat the stega-cipher either.

20 Given that some information can be thus integrated with the content itself, the question is then how best to take advantage of this arrangement in order to protect copyrights.

The following protocol details how the stega-cipher will be exploited to protect copyrights in the digital domain.

25

In a transaction involving the transfer of digitized content, there are at least 3 functions involved:

30 The Authority is a trusted arbitrator between the two other functions listed below, representing parties who actually engage in the transfer of the content. The Authority maintains a database containing information on the particular piece of

content itself and who the two parties engaged in transferring the content are. The Authority can perform stega-cipher encoding and decoding on content.

5 The Publisher, or online distributor is the entity which is sending the copyrighted content to another party. The Publisher can perform stega-cipher encoding and decoding on content.

10 The Consumer is the person or entity receiving the copyrighted content, generally in exchange for some consideration such as money. The consumer cannot generally perform stega-cipher encoding or decoding on content.

15 Each of these parties can participate in a message exchange protocol using well known public-key cryptographic techniques. For instance, a system licensing RSA public key algorithms might be used for signed and encrypted message exchange. This means that each party maintains a public key / private key pair, and that the public keys of each party are freely available to any other party. Generally, the Authority communicates via electronic links directly only to the Publisher and the Consumer communicates directly only with the publisher.

20 Below is an example of how the protocol operates from the time a piece of content enters an electronic distribution system to the time it is delivered to a Consumer.

25 A copyright holder (an independent artist, music publisher, movie studio, etc.) wishes to retail a particular title online. For instance, Sire Records Company might wish to distribute the latest single from Seal, one of their musical artists, online. Sire delivers a master copy of this single, "Prayer for the Dying", to the Authority, Ethical Inc. Ethical converts the title into a format suitable for electronic distribution. This may involve digitizing an analog recording. The title has now become content in the context of this online distribution system. The title is not yet available to anyone except Ethical Inc., and has not yet been encoded with the stega-cipher watermark. Ethical generates a Title Identification and Authentication

30

(TIA) certificate. The certificate could be in any format. In this example it is a short text file, readable with a small word-processing program, which contains information identifying

- 5 the title
- the artist
- the copyright holder
- the body to which royalties should be paid
- general terms for publishers' distribution
- 10 any other information helpful in identifying this content

Ethical then signs the TIA with its own private key, and encrypts the TIA certificate plus its signature with its own public key. Thus, the Ethical can decrypt the TIA certificate at a later time and know that it generated the message and that the

15 contents of the message have not been changed since generation.

Sire Records, which ultimately controls distribution of the content, communicates to the Ethical a specific online Publisher that is to have the right of distribution of this content. For instance, Joe's Online Emporium. The Authority, Ethical Inc. can

20 transmit a short agreement, the Distribution Agreement to the Publisher, Joe's Online Emporium which lists

- the content title
- the publisher's identification
- 25 the terms of distribution
- any consideration paid for the right to distribute the content
- a brief statement of agreement with all terms listed above

The Publisher receives this agreement, and signs it using its private key. Thus, any

30 party with access to the Joe's Online Emporium's public key could verify that the Joe's signed the agreement, and that the agreement has not been changed since

Joe's signed it. The Publisher transmits the signed Distribution Agreement to the Authority, Ethical Inc.

Ethical Inc. now combines the signed TIA certificate and the Distribution
5 Agreement into a single message, and signs the entire message using its private key. Ethical has now created a Publisher Identification message to go into its own stega-cipher channel in the content. Ethical Inc. now generates new stega-cipher masks and encodes this message into a copy of the content using a stega-cipher encoder. The Authority saves the masks as a Receipt in a database, along with information
10 on the details of the transfer, including the title, artist and publisher.

Ethical then transfers this watermarked copy to the Joe's Online Emporium, the Publisher. Well known encryption methods could be used to protect the transfer between the Authority and the Publisher. The Authority may now destroy its copy,
15 which the Publisher has received. The Publisher, Joe's Online Emporium now assumes responsibility for any copies made to its version of the content, which is a Publisher Master copy.

Finally, the Consumer, John Q. Public wishes to purchase a copy of the content
20 from Joe's Online Emporium. Joe's Emporium sends the John Q. Public a short agreement via an electronic communication link, similar to Publisher's Distribution Agreement, only this is a Purchase Agreement, which lists

the content title
25 consumer identification
the terms of distribution
the consideration pas for the content
a brief statement of agreement with the terms above

30 John Q. Public signs this agreement with his private key and returns it to the Joe's Online Emporium. The Publisher, Joe's prepares to encode its own stega-cipher

watermark onto a copy of the content by generating a set of masks for the algorithm. Joe's Online Emporium then stores these masks (a receipt) in its own database, indexed by title and consumer. Joe's Online Emporium signs the agreement received from John Q. Public with the Emporium's own private key, and
5 forwards it to the Authority, Ethical Inc., along with a copy of the masks. It is important to note that this communication should be done over a secured channel. The Authority verifies the Publisher and Consumer information and adds its own signature to the end of the message, approving the transaction, creating a Contract of Sale. The Authority adds the Publisher's receipt (mask set) to its database,
10 indexed by the title, the publisher, and the consumer identification. The Authority signs the Contract of Sale by encrypting it with their private key. So anyone with the Authority's public key (any Publisher) could decrypt the Contract of Sale and verify it, once it was extracted from the content. The Publisher then transmits the signed Contract of Sale back to the Publisher, who uses a stega-cipher device to
15 imprint this Contract as its own watermark over the content. The Publisher then transmits the newly watermarked copy to the Consumer, who is accepting responsibility for it. The Publisher destroys their version of the consumer's copy.

If this procedure is followed for all content distribution within such an online system
20 then it should be possible for the Authority to identify the owner of a piece of content which appears to be unauthorized. The Authority could simply try its database of stega-cipher keys to decode the watermark in the content in question. For instance, if a copy of Seal's latest single originally distributed with stega-cipher watermarks showed up on an Internet ftp site the Authority should be able to
25 extract a TIA Certificate and Distribution Agreement or a Contract of Sale identifying the responsible party. If a Publisher sold this particular copy to a Consumer, that particular publisher should be able to extract a Contract of Sale, which places responsibility with the Consumer. This is not a time critical application, so even if it takes days or weeks, it is still worthwhile.

30

In a modification to the protocol discussed above, each Publisher might act as its own Authority. However, in the context of online services, this could open avenues of fraud committed by the collusion of certain Publishers and Consumers. Using an Authority, or one of several available Authorities to keep records of Publisher-
5 Consumer transactions and verify their details decreases the likelihood of such events.

It should also be obvious that a similar watermarking system could be used by an individual entity to watermark its own content for its own purposes, wether online
10 or in physical media. For instance, a CD manufacturer could incorporate unique stega-cipher watermarks into specific batches of its compact discs to identify the source of a pirate ring, or to identify unauthorized digital copies made from its discs. This is possible because the stega-cipher encoding works with the existing formats of digital samples and does not add any new structures to the sample data
15 that cannot be handled on electronic or mechanical systems which predate the stega-cipher.

VI. Increasing Confidence in the Stega-Cipher

20 The addition of a special pre-encoding process can make stega-cipher certificates even more secure and undeniable. Hash values may be incorporated which match exactly the content containing the watermark to the message in the watermark itself. This allows us a verification that the watermark decoded was encoded by whomever signed it into this precise location in this specific content.

25 Suppose one wants to use a 256 bit (32 byte) hash value which is calculated with a secure one-way hash function over each sample in each sample window that will contain the message. The hash starts with a seed value, and each sample that would be processed by the encoder when encoding the message is incorporated into the
30 hash as it is processed. The result is a 256 bit number one can be highly confident is

unique, or sufficiently rare to make intentionally duplicating it with another series of samples difficult.

5 It is important that the hash function be insensitive to any changes in the samples induced by the stega-cipher itself. For instance, one might ignore the least significant bit of each sample when computing the hash function, if the stega-cipher was implemented using a least significant bit encode mode.

10 Based on the size of the non-hash message, one knows the hash-inclusive message requires 32 more bytes of space. One can now calculate the size of a signed encrypted copy of this message by signing and encrypting exactly as many random bytes as are in the message, and measuring the size of the output in bytes. One now knows the size of the message to be encoded. One can pre-process the sample stream as follows.

15 Proceed through the stega-cipher encode loop as described in the claims. Instead of encoding, however, calculate hash values for each window series which will contain the message, as each sample is processed. At the end of each instance of "encoding" take the resultant hash value and use it to create a unique copy of the message
20 which includes the hash value particular to the series of sample windows that will be used to encode the message. Sign and encrypt this copy of the message, and save it for encoding in the same place in the sample stream.

25 A memory efficient version of this scheme could keep on hand the un-hashed message, and as it creates each new copy, back up in the sample stream to the first window in the series and actually encode each message, disposing of it afterwards.

The important result is evident on decoding. The decoding party can calculate the same hash used to encode the message for themselves, but on the encoded samples.
30 If the value calculated by the decoding party does not match the value contained in the signed message, the decoder is alerted to the fact that this watermark was

transplanted from somewhere else. This is possible only with a hash function which ignores the changes made by the stega-cipher after the hash in the watermark was generated.

- 5 This scheme makes it impossible to transplant watermarks, even with the keys to the stega-cipher.

Appendix - Psuedo-code

```

const int WINDOW_RESET = 256;
const int WINDOW_SIZE = 128;
const int MARKER_BITS = 1024;
const int CHUNK_BITS = 2048 * 8;

int window_offset;
int msg_bit_offset;
int frequency_offset;
Boolean useCell;

/* 8 bits per byte, 1 byte per char */
unsigned char frequency_mask[WINDOW_SIZE/8];
unsigned char window_mask[WINDOW_RESET/8];
unsigned char msg_start_marker[MARKER_BITS/8];
unsigned char msg_end_marker[MARKER_BITS/8];
Int16 amplitude_sample_buffer[WINDOW_SIZE];
float power_frequency_buffer[WINDOW_SIZE];
unsigned char message_buffer[CHUNK_BITS/8];

void doFFT(Int16 *amp_sample_buffer, float *power_freq_buffer,int size);
void doInverseFFT(Int16 *amp_sample_buffer, float *power_freq_buffer,int size);
void initialize();
Bit getBit(unsigned char *buffer,int bitOffset);
Boolean map(Bit window_bit, Bit band_bit, int window, int frequency);
Boolean getSamples(Int16 *amplitude_sample_buffer,int samples);
void encode()

void initialize()
{
    /* message to be encoded is generated */
    /* message is prefixed with 1024 bit msg_start_marker */
    /* message is suffixed with 1024 bit msg_end _marker */
    /* remaining space at end of message buffer padded with random bits */
    window_offset = 0;
    msg_bit_offset = 0;
    frequency_offset = 0;
    frequency_mask loaded
    window_mask loaded
    zeroAmpSampleBuffer();
}

```

```

Boolean getSamples(Int16 *buffer,int samples)
{
    /* get samples number of samples and shift them contiguously into the sample
       buffer from right to left*/
    if(samples < samples available)
        return false;
    else
        return true;
}

void doFFT(Int16 *sample_buffer, float *spectrum_buffer, int size)
{
    calculate FFT on sample_buffer, for size samples
    store result in spectrum buffer
}

void doInverseFFT(Int16 *sample_buffer,float *spectrum_buffer,int size)
{
    calculate inverse FFT on spectrum_buffer
    store result in sampe_buffer
}

Bit getBit(unsigned char *buffer,in bitOffset)
{
    returns value of specified bit in specified buffer
    either 0 or 1, could use Boolean (true/false) values for bit set of bit off
}

Boolean map(Bit window_bit,Bit band_bit,int window, int frequency_
{
    /* this is the function that makes the information difficult to find */
    /* the inputs window_bit and band_bit depend only on the mask values
       used for encoding the information, they are 1) random, 2) secret */
    /* window and frequency values are used add time and frequency band dependent
       complexity to this function */
    /* this function is equivalent to a Boolean truth table with window * frequency * 4
       possible input combinations and 2 possible output */
    /* for any input combination, the output is either true or false */
    /* window ranges from 0 to WINDOW_RESET -1 */
    /* frequency ranges from 0 to WINDOW_SIZE - 1 */
    return calculated truth value
}

```

```

void encodeBit(float *spectrum_buffer,int freq_offset,Bit theBit)
{
    /* modifies the value of the cell in spectrum_buffer, indexed by freq_offset
       in a manner that distinguishes each of the 2 possible values of theBit,
       1 or 0
    */
    /* suggested method of setting the Least Significant bit of the cell == theBit */
    /* alternative method of rounding the value of the cell upward or downward to
       certain fractional values proposed
       i.e. <= .5 fractional remainder signifies 0, > .5 fraction remainder
          signifies 1
    */
}

void encode()
{
    initialize();

    do {

        if(getSamples(amplitude_sample_buffer) == false)
            return

        doFFT(amplitude_sample_buffer,power_frequency_buffer,WINDOW_SIZE);

        for (frequency_offset = 0; frequency_offset < WINDOW_SIZE;
            frequency_offset++){

            useCell = map(getBit(window_mask>window_offset),
                getBit(frequency_mask,frequency_offset),
                window_offset, frequency_offset);

            if(useCell == true){
                encodeBit(power_frequency_buffer,frequency_offset,
                    getBit(message_buffer,msg_bit_offset));
                message_bit_offset ++;
                if(msg_bit_offset == MESSAGEBITS){
                    initialize();
                    break; /* exit frequency loop */
                }
            }
        }
    }
}

```

```

doInverseFFT(amplitude_sample_buffer,power_frequency_buffer,
             WINDOW_SIZE);

outputSamples(amplitude_sample_buffer);

window_offset++;
if(window_offset == WINDOW_RESET){
    window_offset = 0;
}

}while(true);
}

```

The encode() procedure processes an input sample stream using the specified frequency and window masks as well as a pre-formatted message to encode.

encode() processes the sample stream in windows of WINDOW_SIZE samples, contiguously distributed in the sample stream, so it advances WINDOW_SIZE samples at a time.

For each sample window, encode() first compute the FFT of the window, yielding its Power Spectrum Estimation. For each of these window PSEs, encode() then uses the map() function to determine where in each PSE to encode the bits of the message, which it reads from the message buffer, on ebit at a time. Each time map() returns true, encode() consumes another sample from the message.

After each window is encoded, encode() computes the inverse FFT on the PSE to generate a modified sample window, which is then output as the modified signal. It is important the sample windows NOT overlap in the sample stream, since this would potentially damage the preceeding encoding windows in the stream.

Once the message is entirely encoded, including its special end of message marker bit stream, encode() resets its internal variables to begin encoding the message once more in the next window. encode() proceeds in this manner until the input sample stream is exhausted.

```

enum {
    Synchronizing,
    Locked
}; /* decode states */

```



```

unsigned char message_end_buffer[MARKER_BITS];

Bit decodeBit(float *spectrum_buffer,int freq_offset)
{
    /* reads the value of the cell in spectrum_buffer, indexed by freq_offset
       in a manner that distinguishes each of the 2 possible values of an
       encoded bit, 1 or 0
    */
    /* suggested method of testing the Least Significant bit of the cell */
    /* alternative method of checking the value of the cell versus certain fractional
       remainders proposed.
       i.e. <= .5 fractional remainder signifies 0, > .5 fraction remainder
       signifies 1
    */
    return either 1 or 0 as appropriate
}

Boolean decode()
{
    /* Initialization */
    state = Synchronizing
    window_offset = 0;
    set frequency mask
    set window mask
    clear sample buffer
    int nextSamples = 1;
    int msg_start_offset = 0;
    clear message_end_buffer
    Bit aBit;
    Boolean bitsEqual;

    do {

        if(state == Synchronizing){
            nextSamples = 1;
            window_offset = 0;
        }
        else
            nextSamples = WINDOW_SIZE;

        if(getSamples(amplitude_sample_buffer) == false)
            return false;
    }
}

```

```

doFFT(amplitude_sample_buffer,power_frequency_buffer,
      WINDOW_SIZE); /* 2 */

for (frequency_offset = 0; frequency_offset < WINDOW_SIZE;
frequency_offset++){

    useCell = map(getBit(window_mask>window_offset),
                  getBit(frequency_mask,frequency_offset),
                  window_offset, frequency_offset);

    if(useCell == true){
        aBit = decodeBit(power_frequency_buffer,
                        frequency_offset);
        setBit(message_buffer,message_bit_offset,aBit);
        message_bit_offset ++;
    }
    else
        continue;
    if(state == Synchronizing){
        bitsEqual =
        compareBits(message_start_marker,message_buffer,
                    message_bit_offset);
        if(!bitsEqual){
            message_bit_offset = 0;
            misaligned = true;
            break; /* exit frequency loop */
        }
        else if (message_bit_offset == MARKER_BITS)
            state == Locked;
    }
    else {
        /* locked onto encoded stream */
        shift aBit into right side of message_end_buffer
        bitsEqual = compareBits(message_end_buffer,
                                msg_end_marker,MARKER_BITS);
        if(bitsEqual)
            return true;
    }
}

} while (true);
}

```

The `decode()` procedure scans an input sample stream using specified window and frequency masks, until it either decodes a valid message block, storing it in a message buffer, or exhausts the sample stream.

The `decode()` procedure starts in state Synchronizing, in which it does not know where in the sample stream the encoding windows are aligned. The procedure advances the sample window through the sample stream one sample at a time, performing the FFT calculation on each window, and attempting to decode valid message bits from the window. As it extracts each bit using the `map()` function, the `decode()` procedure compares these bits against the start of message marker. As soon as a mismatch is detected, the `decode()` procedure knows it is not yet properly aligned to an encoding window, and immediately ceases decoding bits from the current window and moves to the next window, offset by 1 sample. The `decode()` procedure continues in this manner until it matches successfully the complete bitstream of a start of message marker. At this point the `decode()` procedure assumes it is aligned to an encoded message and can then decode bits to the message buffer quickly, advancing the sample window fully at each iterations. It is now in Locked mode. For each bit it stores in the message buffer when in Locked mode, the `decode()` procedure also shifts the same bit value into the least significant bit of the `message_end_buffer`. After each bit is decoded in Locked mode, the `decode()` procedure checks compares the `message_end_buffer` with the `msg_end_marker` in a bit by bit manner. When a complete match is found, `decode()` is finished and returns true. If the sample stream is exhausted before this occurs, `decode()` returns false. If `decode()` returns true, a valid message is stored in the message buffer, including the start and end of message markers.

Claims

1. A steganographic method comprising the steps of :
using random keys in combination with steganography to encode additional
information into digitized samples such that a signal generated from the modified
5 sample stream is not significantly degraded and such that the additional information
cannot be extracted without the keys and such that the signal generated from the
modified sample stream will be degraded by attempts to erase, scramble, or
otherwise obliterate the encoded additional information.
- 10 2. An apparatus for encoding or decoding a message, represented as
series of data bits into or out of a series of digitized samples, comprising:
- a) a sample buffer for holding and accessing and transforming
digitized samples;
 - b) a digital signal processor capable of performing fast fourier
15 transforms;
 - c) a memory to contain information representing
 - 1) primary mask,
 - 2) convolutional mask,
 - 3) start to message delimiter,
 - 20 4) a mask calculation buffer,
 - 5) a message buffer,
 - 6) an integer representing a message bit index,
 - 7) a position integer M representing message size,
 - 8) an integer representing an index into said primary
25 mask,
 - 9) an integer representing an index into said convolution
mask,
 - 10) an integer representing the state of a decode process,
 - 11) a table representing a map function;
 - 30 12) a flag indicating a complete message has been
decoded or encoded,

- 13) a positive integer S representing a number of samples to read into said sample buffer, and
- 14) a flag indicating the size of a message which has been decoded;
- 5 d) an input to acquire digital samples;
 e) an output to output modified digital samples;
 f) an input for inputting the values of (c1) - (c5) and (c11) and (c13);
- g) an output to output the message stored in (c5) as the result
 10 of a decode process and the value of (c10) to an attached digital circuit;
- h) at least one data bus to transfer information from
 (d) to (a),
 (a) to (b),
 (b) to (a),
 15 (a) to (e),
 (f) to (c), and
 (c) to (e); and
- i) a clock which generates a clock signal to drive (b) and
 20 control the operation of the apparatus.

3. A method of encoding information into a sample stream of data, said method comprising the steps of:

- 25 A) generating a mask set to be used for encoding, said set including:
 a random or pseudo-random primary mask,
 a random or pseudo-random convolution mask,
 a random or pseudo-random start of message
 delimiter, wherein said mask set can be concatenated and manipulated as a single bit
 30 stream;
- B) obtaining a message to be encoded;

- 5 C) generating a message bit stream to be encoded such that the stream includes
- 1) a start of message delimiter, and
 - 2) an integer representing the number of message bytes to follow the message;
- D) loading the message bit stream, a map table, the primary mask, the convolution mask, and the start of message delimiter into a memory;
- 10 E) resetting a primary mask index, a convolution mask and message bit index, and setting the message size integer equal to the total number of bits in the message bit stream;
- F) clearing a message encoded flag;
- G) reading a window of samples from a sample input device and storing them sequentially in a sample buffer;
- 15 H) resetting the primary mask index and looping through the sample buffer from a first sample to a last sample incrementing the primary mask index each time a sample is visited, such that for each sample position, a value of the mapping function is computed, which is either true or false, by using a bit of the primary mask representing a current sample and a bit of the convolution mask
- 20 indicated by the convolution index to calculate an offset in the map table;
- I) obtaining the bit value stored in the map table and encoding the bit of the message indicated by the message bit index into the current sample if the bit value obtained from the map table is a certain value and incrementing the message bit index, determining whether the message bit index equals the number of
- 25 message bits, and if it does re-performing step A), setting the message encoded flag, and exiting the loop;
- J) outputting the modified samples in the sample buffer, and if the message encoded flag is set jumping back to said step E);
- 30 K) incrementing the convolution index, wherein if the convolution index equals the length of the convolution mask in bits then set the convolution index to 0; and

L) jumping back to step G).

4. A method of encoding information into a sample stream of data, comprising the steps of:

- 5 A) generating a mask set to be used for encoding, including:
a random or pseudo-random primary mask,
a random or pseudo-random convolution mask, and
a random or pseudo-random start of message
delimiter, wherein said mask set can be concatenated and manipulated as a single bit
10 stream;
- B) inputting a message to be encoded;
- C) generating a message bit stream to be encoded including
a start of message delimiter, and
an integer representing of number of message bytes to
15 follow the message;
- D) loading the message bit stream, a map table, and the mask set
into a memory;
- E) resetting a primary mask index, a convolution mask and
message bit index, setting the message size index equal to the number of bits in the
20 message bitstream, and clearing a message encoded flag;
- F) reading a window of samples of the inputted message and
storing the samples sequentially in a sample buffer;
- G) computing a spectral transform of the samples in the buffer;
- H) obtaining the bit value stored in the map table, wherein if the
25 bit value is true, then encoding the bit of the message indicated by the message bit
index into the current sample and incrementing the message bit index, where the
message bit index equals the number of message bits, and then reperforming step
A), setting the message encoded flag, and exiting the loop;
- I) computing the inverse spectral of the spectral values stored
30 in the sample buffer;

J) outputting the values in the sample buffer, and if the sample encoded flag is set, then clear the flag and jump back to step E);

K) incrementing the convolution index and when the convolution index equals the length of the convolution mask in bits resetting the convolution index; and

L) jumping back to step F).

5. The method of claim 3 wherein the encoding of the message bit into the sample in step I includes encoding a single bit of the sample to match the message bit.

6. The method of claim 4 wherein the encoding of the message bit into the sample in step H includes altering the sample value such that said sample value falls within a prespecified range of values relative to its original value.

7. A method of decoding information from a sample stream of data, comprising the steps of:

A) obtaining a mask set including:

(1) a random or pseudo-random primary mask,

(2) a random or pseudo-random convolution mask, and

(3) a random or pseudo-random start of message delimiter;

B) loading a map table, and the mask set into a memory;

C) resetting a primary mask index and convolution mask index and setting a message size integer equal to 0;

D) clearing a message decoded flag;

E) setting a state of the decode process to SYNCHRONIZED;

F) checking the state of the decode process and if the decode state is UNSYNCHRONIZED, setting a number of samples to equal 1 and resetting the convolution index to 0; otherwise, setting the number of samples to equal S ($S \geq 1$);

- G) reading the number of samples specified in step F) into a sample buffer;
- H) resetting the primary mask index, and looping through the sample buffer from the first sample to the last sample, incrementing the primary mask index each time, and for each sample position, computing the value of a mapping function to calculate an offset into the map table;
- I) obtaining the bit value in the map table, and if the value is true, decoding the bit of the message indicated by the message bit index, storing the bit into the message buffer at the message bit index, and incrementing the message bit index;
- J) comparing the decoded bits in the message buffer to the start of message delimiter, and if the number of bits in the message buffer is less than or equal to the number of bits in the start of message delimiter and the bits match, then setting the state of the decode process to SYNCHRONIZED; otherwise setting the state of the decode process to UNSYNCHRONIZED;
- K) if the state of the decode process is SYNCHRONIZED and the number of bits in the message buffer is greater than or equal to the sum of the number of bits of the start of delimiter and the message size, then setting the state of the decode process to SYNC-AND-SIZE and copying certain bits from the message buffer to a message size integer container;
- L) if the state of the decode process is SYNC-AND-SIZE and the number of bits in the message buffer divided by 8 is greater than or equal to the message size, then setting the message decoded flag, outputting the message and the message decoded flag and ending the method;
- M) incrementing the convolution index, and if the convolution index equals the number of bits in the convolution mask resetting the convolution index; and
- N) jumping to step F).
8. A method of decoding information from sampled data, comprising the steps of:

- 5 A) Obtaining a mask set including
- (1) a random or pseudo-random primary mask,
 - (2) a random or pseudo-random convolution mask, and
 - (3) a random or pseudo-random start of message
- delimiter;
- B) loading a map table, and the mask set into a memory;
- C) resetting a primary mask index and convolution mask index
- and setting a message size integer equal to 0;
- D) clearing a message decoded flag;
- 10 E) setting a state of the decode process to SYNCHRONIZED;
- F) checking the state of the decode process and if the decode
- state is UNSYNCHRONIZED, setting a number of samples to equal 1 and resetting
- the convolution index to 0; otherwise, setting the number of samples to equal S
- (S>1);
- 15 G) reading the number of samples specified in step F) into a
- sample buffer;
- H) computing a spectral transform of the samples stored in the
- sample buffer;
- I) resetting the primary mask index and looping through the
- 20 sample buffer from the first sample to the last sample, incrementing the primary
- mask index each time, and for each sample position, computing the value of a
- mapping function by using the bit of the primary mask corresponding to the primary
- mask index and the bit of the convolution masks indicated by the convolution phase
- to calculate an offset into the map table representing the mapping function;
- 25 J) obtaining a bit value stored in the map, and if the value is
- true, decoding the bit of the message indicated by the message bit index from the
- current sample, storing the bit into the message buffer at the message bit index, and
- incrementing the message bit index;
- 30 K) comparing the decoded bits in the message buffer to the start
- of message delimiter, and if the number of bits in the message buffer is less than or
- equal to the number of bits in the start of message delimiter and the bits match, then

setting the state of the decode process to SYNCHRONIZED; otherwise, setting the state of the decode process UNSYNCHRONIZED;

5 L) if the state of the decode process is SYNCHRONIZED, and the number of bits in the message buffer is greater than or equal to the sum of the number of bits of the start of delimiter and the message size, then setting the state of the decode process to SYNC-AND-SIZE and copying certain bits from the message buffer to a message size integer container;

10 M) if the state of the decode process is SYNC-AND-SIZE and the number of bits in the message buffer divided by 8 is greater than or equal to the message size, then setting the message decoded flag, outputting the message and the message decoded flag and ending the method;

N) incrementing the convolution index, wherein if the convolution index equals the number of bits in the convolution mask, then resetting the convolution index; and

15 O) jumping to step F).

9. The method of claim 7 wherein the decoding of the message bit from the sample in step I includes reading a single bit of the sample.

20 10. The method of claim 7 wherein the decoding of the message bit from the sample in step I includes mapping a range of sample values onto a particular message bit value.

25 11. The method of claim 4 wherein the map table is defined such that any index of the map table directs the process to encode information.

12. The method of claim 1 wherein the samples are obtained from a sample stream representing digitized sound or music.

13. The method of claim 12 wherein the identical encode process is performed on two sample streams representing channel A and channel B of digitized stereo sound.
- 5 14. The method of claim 12 wherein the sample streams represent channel A and channel B of digitized stereo sound and are interleaved before being input as a single sample stream and are separated into two channels upon output.
- 10 15. The method of claim 1 wherein the samples are obtained from a sample stream representing digitized video.
16. The method of claim 1 wherein the samples are obtained from a sample stream representing a digitized image.
- 15 17. The apparatus of claim 2, further comprising a tamper-resistant packaging, enclosing said apparatus wherein circuitry and information stored therein are destroyed if said packaging is opened.
- 20 18. The method of claim 3, further comprising a pre-encoding step which customizes the message to be encoded including: calculating over which windows in the samples stream a message will be encoded, computing a secure one way hash function of the samples in those windows, and placing the resulting hash values in the message before the message is encoded;
- 25 wherein the hash calculating step includes: calculating the size of the original message plus the size of an added hash value, and pre-processing the sample stream for the purpose of calculating hash values of each series of windows that will be used to encode the message and creating a modified copy of the message containing the hash value such that each message containing a hash value matches each window series uniquely.
- 30

19. The method of claim 1, wherein an authority for on line distribution of content encodes at least one of the following items into a sample stream ;
- the title,
 - the artist,
 - 5 the copyright holder,
 - the body to which royalties should be paid, and
 - general terms for publisher distribution.
20. The method of claim 19, wherein the authority combines at least one item
- 10 with a secure private key signed message from a publisher containing at least one of the following pieces of information:
- the title,
 - the publisher's identification,
 - the terms of distribution,
 - 15 any consideration paid for the right to distribute the content,
 - a brief statement of agreement, and
- the publisher signs and encrypts the combined message using a public key cryptosystem and encodes the signed and encrypted message into the sample stream.
- 20
21. The method of claim 20, wherein a publisher obtains the encoded sample stream and additionally obtains information form the authority and combines this with a message received from a consumer, which has been signed using a public key cryptosystem and wherein the signed message contains at least one of the following
- 25 data
- the content title,
 - consumer identification,
 - the terms of distribution,
 - the consideration paid for the content,
 - 30 a brief statement of agreement, and

the publisher uses a public key cryptosystem to sign the combined information and finally encodes the signed information.

5 22. The method of claim 1, wherein the sample stream is obtained from at least one audio track contained within a digitized movie, video game software, or other software.

10 23. The method of claim 1, wherein the sample stream is obtained from at least one digitized movie or still image contained within a video game or other software.

24. The method of claim 1, wherein encoded information is contained in the differences or relationship between samples or groups of samples.

15 25. The method of claim 4, wherein the encoding of the message bit into the sample in step H includes encoding a single bit of the sample to match the message bit.

20 26. The method of claim 3, wherein the encoding of the message bit into the sample in step I includes altering the sample value such that said sample value falls within a prespecified range of values relative to its original value.

27. The method of claim 8, wherein the decoding of the message bit in step J includes reading a single bit of the sample.

25 28. The method of claim 8, wherein the decoding of the message bit in step J includes mapping a range of sample values onto a particular message bit value.

30 29. The method of claim 3, wherein the map table is defined such that any index of the map table directs the process to encode information.

30. The method of claim 7, wherein the map table is defined such that any index of the map table directs the process to encode information.

5 31. The method of claim 8, wherein the map table is defined such that any index of the map table directs the process to encode information.

10 32. The method of claim 4, further comprising a pre-encoding step which customizes the message to be encoded including: calculating over which windows in the samples stream a message will be encoded, computing a secure one way hash function of the samples in those windows, and placing the resulting hash values in the message before the message is encoded;

15 wherein the hash calculating step includes: calculating the size of the original message plus the size of an added hash value, and pre-processing the sample stream for the purpose of calculating hash values of each series of windows that will be used to encode the message and creating a modified copy of the message containing the hash value such that each message containing a hash value matches each window series uniquely.--

20



(11) **EP 0 872 073 B1**

(12) **EUROPEAN PATENT SPECIFICATION**

(45) Date of publication and mention of the grant of the patent:
28.11.2007 Bulletin 2007/48

(21) Application number: **96919405.9**

(22) Date of filing: **07.06.1996**

(51) Int Cl.:
H04L 9/00 (2006.01) H04N 1/32 (2006.01)

(86) International application number:
PCT/US1996/010257

(87) International publication number:
WO 1996/042151 (27.12.1996 Gazette 1996/56)

(54) **STEGANOGRAPHIC METHOD AND DEVICE**

STEGANOGRAPHISCHES VERFAHREN UND EINRICHTUNG

PROCEDE ET DISPOSITIF STEGANOGRAPHIQUES

(84) Designated Contracting States:
AT BE CH DE DK ES FI FR GB GR IE IT LI LU MC NL PT SE

(30) Priority: **07.06.1995 US 489172**

(43) Date of publication of application:
21.10.1998 Bulletin 1998/43

(60) Divisional application:
07112420.0 / 1 843 507

(73) Proprietor: **Wistaria Trading, Inc.**
Sunny Isles Beach FL 33160 (US)

(72) Inventors:
• **COOPERMAN, Marc, S.**
Short Hills, NJ 07078 (US)
• **MOSKOWITZ, Scott, A.**
c/o Wistaria Trading, Inc.
Sunny Isles Beach, Florida 33160 (US)

(74) Representative: **Vossius & Partner**
Siebertstrasse 4
81675 München (DE)

(56) References cited:
EP-A- 0 581 317 US-A- 4 908 873
US-A- 4 979 210 US-A- 5 073 925
US-A- 5 287 407 US-A- 5 365 586
US-A- 5 408 505 US-A- 5 412 718

- **BENDER W ET AL: "TECHNIQUES FOR DATA HIDING" PROCEEDINGS OF THE SPIE, SPIE, BELLINGHAM, VA, US, vol. 2420, 9 February 1995 (1995-02-09), pages 164-173, XP000566794 ISSN: 0277-786X**
- **ZHAO J ET AL: "EMBEDDING ROBUST LABELS INTO IMAGES FOR COPYRIGHT PROTECTION" PROCEEDINGS OF THE KNOWRIGHT. CONFERENCE. PROCEEDINGS OF THE INTERNATIONAL CONGRESS ON INTELLECTUAL PROPERTY RIGHTS FOR SPECIALIZED INFORMATION, KNOWLEDGE AND NEW TECHNOLOGY, XX, XX, 1995, pages 242-251, XP000571967**

Note: Within nine months from the publication of the mention of the grant of the European patent, any person may give notice to the European Patent Office of opposition to the European patent granted. Notice of opposition shall be filed in a written reasoned statement. It shall not be deemed to have been filed until the opposition fee has been paid. (Art. 99(1) European Patent Convention).

EP 0 872 073 B1

Description**Definitions**

5 [0001] Several terms of art appear frequently in the following. For ease of reference they are defined here as follows:

[0002] "Content" refers to multimedia content. This term encompasses the various types of information to be processed in a multimedia entertainment system. Content specifically refers to digitized audio, video or still images in the context of this discussion. This information may be contained within files on a multimedia computer system, the files having a particular format specific to the modality of the content (sound, images, moving pictures) or the type of systems, computer or otherwise, used to process the content.

10 [0003] "Digitized" refers to content composed of discrete digital samples of an otherwise analog media, which approximate that media inside a computer or other digital device. For instance, the sound of music occurs naturally, and is experienced by humans as an analog (continuous) sound wave. The sound can be digitized into a stream of discrete samples, or numbers, each of which represents an approximate value of the amplitude of the real analog wave at a particular instant in time. These samples can be stored in files in a computer and then used to recreate the original sound wave to a high degree of accuracy.

15 In general, content entering a digital system is digitized by Analog to Digital converters (A/D) and analog media are recreated by the digital system using a Digital to Analog (D/A) converter. In the context of this discussion content is always digitized content.

20 [0004] "Cryptography" is a field covering numerous techniques for scrambling information conveying messages so that when the message is conveyed between the sender and receiver an unintended party who intercepts this message cannot read it, or extract useful information from it.

[0005] A "Public Key Cryptosystem" is a particular cryptographic system where all parties possess pairs of keys for encryption and decryption. Parties to this type of system freely distribute their public keys, which other may use to encrypt messages to the owner of the public key. Such messages are decrypted by the receiver with the private key. Private keys are never distributed. A message encrypted with a public key can only be decrypted with the corresponding private key, and vice versa. A message encrypted with a private key is said to have been signed by the owner of that key. Anyone in possession of the public key may decrypt the message and know that it was encrypted, and thus signed, by the owner of the public key, since only they possess the corresponding private key.

25 [0006] "Steganography" is a field distinguished from cryptography, but associated with it, that covers numerous methods for hiding an informational message within some other medium, perhaps another unrelated message, in such a manner that an unintended party who intercepts the medium carrying the hidden message does not know it contains this hidden message and therefore does not obtain the information in the hidden message. In other words, steganography seeks to hide messages in plain view.

35

Background of the Invention

[0007] In the current environment of computer networks and the proliferation of digital or digitized multimedia content which may be distributed over such networks, a key issue is copyright protection. Copyright protection is the ability to prevent or deter the proliferation of unauthorized copies of copyrighted works. It provides a reasonable guarantee that the author of a copyrighted work will be paid for each copy of that work.

40 [0008] A fundamental problem in the digital world, as opposed to the world of physical media, is that a unlimited number of perfect copies may be made from any piece of digital or digitized content. A perfect copy means that if the original is comprised of a given stream of numbers, then the copy matches the original, exactly, for each number in the stream. Thus, there is no degradation of the original signal during the copy operation. In an analog copy, random noise is always introduced, degrading the copied signal.

45 [0009] The act of making unlicensed copies of some content, digital or analog, whether audio, video, software or other, is generally known as *piracy*. Piracy has been committed for the purpose of either profit from the sale of such unlicensed copies, or to procure for the "pirate" a copy of the content for personal use without having paid for it.

50 [0010] The problem of piracy has been made much worse for any type of content by the digitization of content. Once content enters the digital domain, an unlimited number of copies may be made without any degradation, if a pirate finds a way to break whatever protection scheme was established to guard against such abuses, if any. In the analog world, there is generally a degradation in the content (signal) with each successive copy, imposing a sort of natural limit on volume of piracy.

55 [0011] To date, three general types of schemes have been implemented in an attempt to protect copyrights.

- 1) Encryption
- 2) Copy Protection

3) Content Extensions

[0012] Copy Protection and Content Extensions generally apply in the digital world only, while a scheme related to Encryption, commonly known as scrambling, may be applied to an analog signal. This is typical in analog cable systems.

5 [0013] **Encryption** scrambles the content. Before the content is made ready for delivery, whether on floppy disk, or over a network, it must be encrypted, or scrambled. Once the content has been encrypted, it cannot be used until it is decrypted, or unscrambled. Encrypted audio data might sound like incomprehensible screeching, while an encrypted picture or video might appear as random patterns on a screen. The principle of encryption is that you are free to make as many copies as you want, but you can't read anything that makes sense until you use a special key to decrypt, and

10 you can only obtain the key by paying for the content.

[0014] Encryption has two problems, however. 1) Pirates have historically found ways to crack encryption, in effect, obtaining the key without having paid for it; and 2) Once a single legitimate copy of some content has been decrypted, a pirate is now free to make unlimited copies of the decrypted copy. In effect, in order to sell an unlimited quantity of an encrypted piece of software, the pirate could simply buy one copy, which they are entitled to decrypt.

15 [0015] **Copy Protection** includes various methods by which a software engineer can write the software in a clever manner to determine if it has been copied, and if so to deactivate itself. Also included are undocumented changes to the storage format of the content. Copy protection was generally abandoned by the software industry, since pirates were generally just as clever as the software engineers and figured out ways to modify their software and deactivate the protection. The cost of developing such protection was not justified considering the level of piracy which occurred despite

20 the copy protection.

[0016] **Content Extension** refers to any system which attaches some extra information to the original content which indicates whether or not a copy may be made. A software or hardware system must be specifically built around this scheme to recognize the additional information and interpret it in an appropriate manner. An example of such a system is the Serial Copyright Management System embedded in Digital Audio Tape (DAT) hardware. Under this system,

25 additional information is stored on the disc immediately preceding each track of audio content which indicates whether or not it can be copied. The hardware reads this information and uses it accordingly.

[0017] A fundamental problem with Encryption and Content Extension is the "rogue engineer". An employee who helped design such a system or an individual with the knowledge and means to analyze such a system can modify it to ignore the copyright information altogether, and make unlicensed copies of the content. Cable piracy is quite common,

30 aided by illicit decoder devices built by those who understand the technical details of the cable encryption system. Although the cable systems in question were actually based on analog RF signals, the same principle applies to digital systems.

[0018] The practical considerations of weak encryption schemes and rogue engineers have served to limit the faith which may be put in such copyright protection schemes. The invention disclosed herein serves to address these problems with conventional systems for digital distribution. It provides a way to enforce copyright online. The invention draws on techniques from two fields, cryptography, the art of scrambling messages so that only the intended recipient may read them, and steganography, a term applied to various techniques for obscuring messages so that only the intended parties to a message even know that a message has been sent, thus it is termed herein as a stega-cipher. The stega-cipher is so named because it uses the steganographic technique of hiding a message in multimedia content, in combination with

40 multiple keys, a concept originating in cryptography. However, instead of using the keys to encrypt the content, the stega-cipher uses these keys to locate the hidden message within the content. The message itself is encrypted which serves to further protect the message, verify the validity of the message, and redistribute the information in a random manner so that anyone attempting to locate the message without the keys cannot rely on pre-supposed knowledge of the message contents as a help in locating it.

45 [0019] EP-A-0581317 discloses a method and system for embedding signatures within visual images in both digital representation and print or film, wherein a signature is inseparably embedded within the visual image, signature points being selected from among the pixels of an original image, wherein the pixel values of the signature points and surrounding pixels are adjusted by an amount detectable by a digital scanner.

[0020] Bender W. et al describe in Proceedings of the SPIE, SPIE, Bellingham, VA, US, Vol. 2420, 9 February 1995, pages 164 to 173 techniques for data hiding.

50

Summary of the Invention

[0021] The invention disclosed herein combines two techniques, steganography - obscuring information that is otherwise in plain sight, and cryptography - scrambling information that must be sent over unsecured means, in a manner such that only the intended recipient may successfully unscramble it. The net effect of this system is to specifically watermark a piece of content so that if it is copied, it is possible to determine who owned the original from which the copies were made, and hence determine responsibility for the copies. It is also a feature of the system to uniquely identify

the content to which it is applied.

[0022] For a comprehensive discussion of cryptography, its theory, applications and specific algorithms, see APPLIED CRYPTOGRAPHY, by Bruce Schneier, which is herein incorporated by reference at pages 66-68, 387-392.

5 [0023] Steganography is discussed briefly in THE CODE BREAKERS by David Kahn, which is herein incorporated by reference at pages xiii, 81-83, 522-526, and 873. An example application, Stego by Romana Machado, is also available for the Apple Macintosh. Stego can be found at the internet uniform resource locator "ftp://sumex-aim.stanford.edu/info-mac/cmp/stego10a2.hqx". This application demonstrates a simple steganographic technique to encode a text message into a graphical image without significantly distorting the image.

10 [0024] The invention improves upon the prior art by providing a manner for protecting copyright in the digital domain, which neither steganography or cryptography does. It improves specifically on steganography by making use of special keys which dictate exactly where within a larger chunk of content a message is to be hidden, and makes the task of extracting such a message without the proper key the equivalent of looking for a needle in a haystack.

15 [0025] The information encoded by the Stega-Cipher process serves as a watermark which identifies individual copies of content legally licensed to specific parties. It is integral with the content. It cannot be removed by omission in a transmission. It does not add any overhead to signal transmission or storage. It does allow the content to be stored to and used with traditional offline analog and digital media, without modification or significant signal degradation. These aspects of the stega-cipher all represent improvements to the art. That is, its forces would - be pirates to damage the content in order to guarantee the disabling of the watermark.

20 [0026] The invention described herein is used for protecting and enforcing copyrights in the digital or on-line domain, where there are no physical limitations on copying copyrighted content.

[0027] The invention uniquely identifies every copy of multimedia content made using the invention, composed of digitized samples whether compressed or uncompressed, including but not limited to still digital images, digital audio, and digital video.

25 [0028] The invention is for use in meterware or pay-by-use systems where an online user incurs a charge each time they access a particular piece of content, or uses a software title.

[0029] The invention is for use as a general improvement to cryptographic techniques to increase the complexity of cryptanalysis on a given cipher.

30 [0030] It is considered that the method and steps of the present invention will be modified to account for the effects of loss compression schemes on the samples and particularly includes modification to handle MPEG compressed audio and video.

[0031] It is considered that statistical data spreading and recovery techniques, error coding or spread spectrum processing techniques might be applied in the invention to handle the effects of loss compression, or counter the effects of a randomization attack.

35 [0032] It is considered that the apparatus described might be further specialized and optimized in hardware by replacing general purpose data buses and CPU or DSP driven operations with hardwired circuitry, incorporated in one or more special purpose ICs.

[0033] It is considered that the apparatus will be modeled and implemented in software on general purpose computer platforms.

40 [0034] It is considered that stega-cipher hardware could be embedded in a consumer electronics device and used to not only identify content and copyright, but to enable use of that content.

Detailed Description

I. Digital Copyright Stega-Cipher Protocol and the Decode/Encode Program

45 [0035] The purpose of the program described here is to watermark digital multimedia content for distribution to consumers through online services in such a way as to meet the following criteria Given a unique piece of multimedia content, composed of digitized samples, it is desirable to:

50 1) Uniquely identify this particular piece of content from others in a manner which is secure and undeniable (e.g. to know whether a digital audio recording is "My Way" by Frank Sinatra, or "Stairway to Heaven", by Led Zeppelin), and in a manner such that this identification can be performed automatically by an electronic device or mechanism.

55 2) Uniquely identify the copyright owner of the content, and the terms under which it may be distributed in general, in a manner which is secure and undeniable.

3) At such time as is necessary, additionally, uniquely identify in a secure and undeniable manner the licensed publisher who received a particular copy of the content, and the terms under which they may redistribute or resell it.

4) At such time as is necessary, additionally, uniquely identify in a secure and undeniable manner, the licensed subscriber who received a particular copy of the content from the publisher described in item 3.

5 [0036] The program described in more detail below combines the techniques of cryptography and steganography to hide a securely encrypted digital copyright certificate which contains information satisfying the criteria listed above, in such a manner as to be integral with the content, like a watermark on paper, so that possession of the content dictates possession of the watermark information. In addition, the watermark cannot be "found" or successfully decoded, without possession of the correct "masks" or keys, available only to those legitimately authorized, namely, those parties to a commercial transaction involving the sale of a copy of the content. Finally, the ability to distribute such watermarked content in a system which implements the watermark scheme is denied without a successfully decoded watermark.

10 Because well known and tested cryptographic techniques are used to protect the certificate itself, these certificates are virtually impossible to forge. Finally, the watermark cannot be erased without significantly damaging the content. [0037] The basic program represents a key part of the invention itself. This program is then used as the method by which copyright information is to be associated in an integral manner with the content. This is a concept absent from copy protection, encryption and content extension schemes. The copyright information itself can be made undeniable and unforgeable using cryptographic techniques, so that through it an audit trail of ownership may be established for each copy of a given piece of content, thus customizing each copy to a particular owner, in a way that can be used to identify the owner.

15 [0038] The value of the stega-cipher is that it provides a way to watermark the content in a way that changes it slightly, but does not impact human perception significantly. And, furthermore, that it is made difficult to defeat since one must know exactly where the information resides to extract it for analysis and use in forgery attempts, or to remove it without overly degrading the signal. And, to try to forge copyright information one must first be able to analyze the encrypted copyright information, and in order to do that, one must be able to find it, which requires masks.

25 **II. Example Embodiment of General Processing**

[0039] Digital audio data is represented by a series of samples in 1 dimension,

30
$$\{S_1, S_2, S_3 \dots S_n\}$$

[0040] This series is also referred to as a sample stream. The sample stream approximates an analog waveform of sound amplitude over time. Each sample represents an estimate of the wave amplitude at the instant of time the sample is recorded. For monaural audio, there is one such sample stream. Stereo audio is comprised of two sample streams, one representing the right channel, and the other representing the left. Each stream is used to drive a corresponding speaker to reproduce the stereo sound.

35 [0041] What is referred to as CD quality audio is characterized by 16 bit (2 byte) stereo samples, recorded at 44.1 Khz, or 44,100 samples per second in each channel. The dynamic range of sound reproduction is directly proportional to the number of bits per sample. Some lower quality recordings are done at 8 bits. A CD audio recording can be stored using any scheme for containing the 2 sample streams in their entirety. When these streams are played back at the same frequency they were recorded at, the sound recorded is reproduced to a high degree of accuracy.

40 [0042] The sample stream is processed in order from first sample to last. For the purpose of the invention disclosed, the stream is separated into sample windows, each of which has a fixed number of consecutive samples from the stream, and where windows do not overlap in the sample stream. Windows may be contiguous in the sample stream. In this discussion assume each window contains 128 samples, and that windows are contiguous. So, the windows within the stream look like

45
$$\{[S_1, S_2, S_3 \dots S_{128}], [S_{129}, S_{130}, S_{131} \dots S_{256}], \dots [S_{n-128} \dots S_n] \}$$

50 where [...] denotes each window and any odd samples at the end of the stream which do not completely fill a window can be ignored, and simply passed through the system unmodified.

55 [0043] These windows will be used as input for the discrete Fast Fourier Transform (and its inverse) operation.

[0044] Briefly, Fourier Transform methods are based on the principle that a complex waveform, expressed as amplitude over time and represented by a sample stream, is really the sum of a number of simple waveforms, each of which oscillate at different frequencies.

[0045] By complex, it is meant that the value of the next sample is not easily predicted from the values of the last N samples or the time of the sample. By simple it is meant that the value of the sample is easily predictable from the values of the last N samples and/or the time of the sample.

[0046] The sum of multiple simple waves is equivalent to the complex wave. The discrete FFT and its inverse simply translate a limited amount of data from one side of this equivalence to the other, between the complex waveform and the sum of simple waves. The discrete FFT can be used to translate a series of samples representing amplitude over time (the complex wave, representing a digital audio recording) into the same number of samples representing total spectral energy in a given range of frequencies (the simple wave components) at a particular instant of time. This instant is the time in the middle of the original amplitude/time samples. The inverse discrete FFT translates the data in the other direction, producing the complex waveform, from its simpler parts.

[0047] Each 128 sample window will be used as an input to the discrete FFT, resulting in 128 bins representing each of 128 frequency bands, ranging from 0Hz to 22KHz (the Nyquist frequency, or $\frac{1}{2}$ the sampling rate).

[0048] Information can be encoded into the audio signal in the frequency domain or in the time domain. In the latter case, no FFT or inverse FFT is necessary. However, encoding in the frequency domain is recommended, since its effects are scattered over the resultant time domain samples, and not easily predicted. In addition, frequency domain encoding makes it more likely that randomization will result in noticeable artifacts in the resultant signal, and therefore makes the stega-cipher more defensible against such attacks. It is in the frequency domain that additional information will be encoded into the audio signal for the purpose of this discussion. Each frequency band in a given time slice can potentially be used to store a small portion of some additional information to be added to the signal. Since these are discrete estimates, there is some room for error which will not significantly effect the perceived quality of the signal, reproduced after modification, by the inverse FFT operation. In effect, intentional changes, which cannot be distinguished from random variations are introduced in the frequency domain, for the purpose of storing additional information in the sample stream. These changes are minimized so as not to adversely affect the perceived quality of the reproduced audio signal, after it has been encoded with additional information in the manner described below. In addition, the location of each of these changes is made virtually impossible to predict, an innovation which distinguishes this scheme from simple steganographic techniques.

[0049] Note that this process differs from the Nagata, et al. patents, 4,979,210 and 5,073,925, which encode information by modulating an audio signal in amplitude/time domain. It also differs in that the modulations introduced in the Nagata process (which are at very low amplitude and frequency relative to the carrier wave as to remain inaudible) carry only copy/ don't copy information, which is easily found and circumvented by one skilled in the art. Also, there is no limitation in the stega-cipher process as to what type of information can be encoded into the signal, and there is more information storage capacity, since the encoding process is not bound by any particular frequency of modulation but rather by the number of samples available. The granularity of encoding in the stega-cipher is determined by the sample window size, with potentially 1 bit of space per sample or 128 bits per window (a secure implementation will halve this to 64 bits). In Nagata, et al. the granularity of encoding is fixed by the amplitude and frequency modulation limits required to maintain inaudibility. These limits are relatively low, and therefore make it impractical to encode more than simple copy/ don't copy information using the Nagata process.

III. Example Embodiment of Encoding and Decoding

[0050] A modification to standard steganographic technique is applied in the frequency domain described above, in order to encode additional information into the audio signal.

[0051] In a scheme adapted from cryptographic techniques, 2 keys are used in the actual encode and decode process. For the purposes of this invention the keys are referred to as masks. One mask, the primary, is applied to the frequency axis of FFT results, the other mask is applied to the time axis (this will be called the convolution mask). The number of bits comprising the primary mask are equal to the sample window size in samples (or the number of frequency bands computed by the FFT process), 128 in this discussion. The number of bits in the convolution mask are entirely arbitrary. This implementation will assume a time mask of 1024 bits. Generally the larger the key, the more difficult it is to guess.

[0052] Prior to encoding, the primary and convolution masks described above are generated by a cryptographically secure random generation process. It is possible to use a block cipher like DES in combination with a sufficiently pseudo-random seed value to emulate a cryptographically secure random bit generator. These keys will be saved along with information matching them to the sample stream in question in a database for use in decoding, should that step become necessary.

[0053] Prior to encoding, some additional information to be encoded into the signal is prepared and made available to the encoder, in a bit addressable manner (so that it may be read one bit at a time). If the size of the sample stream is known and the efficiency characteristics of the stega-cipher implementation are taken into account, a known limit may be imposed on the amount of this additional information.

[0054] The encoder captures one sample window at a time from the sample stream, in sequential, contiguous order.

EP 0 872 073 B1

The encoder tracks the sequential number of each window it acquires. The first window is 0. When the number of windows processed reaches the number of bits in the window mask, minus one, the next value of the window counter will be reset to 0.

5 **[0055]** This counter is the convolution index or phase. In the current implementation it is used as a simple index into the convolution bitmask. In anticipated developments it will be used to perform convolution operations on the convolution mask to determine which bit to use. For instance the mask might be rotated by a number corresponding to the phase, in bits to the left and XORed with the primary mask to produce a new mask, which is then indexed by the phase. There are many possibilities for convolution.

[0056] The encoder computes the discrete FFT of the sample window.

10 **[0057]** Starting with the lowest frequency band, the encoder proceeds through each band to the highest, visiting each of the 128 frequency bands in order. At each band value, the encoder takes the bit of the primary mask corresponding to the frequency band in question, the bit of the convolution mask corresponding to the window in question, and passes these values into a boolean function. This function is designed so that it has a near perfectly random output distribution. It will return true for approximately 50% of its input permutations, and false for the other 50%. The value returned for a given set of inputs is fixed, however, so that it will always return the same value given the same set of inputs.

15 **[0058]** If the function returns true, the current frequency band in the current window is used in the encoding process, and represents a valid piece of the additional information encoded in the signal. If the function returns false, this cell, as the frequency band in a given window is called, is ignored in the process. In this manner it is made extremely difficult to extract the encoded information from the signal without the use of the exact masks used in the encoding process. This is one place in which the stega-cipher process departs from traditional steganographic implementations, which offer a trivial decode opportunity if one knows the information is present. While this increases the information storage capacity of the carrier signal, it makes decoding trivial, and further degrades the signal. Note that it is possible and desirable to modify the boolean cell flag function so that it returns true < 50% of the time. In general, the fewer cells actually used in the encode, the more difficult they will be to find and the less degradation of content will be caused, provided the function is designed correctly. There is an obvious tradeoff in storage capacity for this increased security and quality.

20 **[0059]** The encoder proceeds in this manner until a complete copy of the additional information has been encoded in the carrier signal. It will be desirable to have the encoder encode multiple copies of the additional information continuously over the duration of the carrier signal, so that a complete instance of this information may be recovered from a smaller segment of a larger signal which has been split into discontinuous pieces or otherwise edited. It is therefore desirable to minimize the size of the information to be encoded using both compact design and pre-encoding compression, thus maximizing redundant encoding, and recoverability from smaller segments. In a practical implementation of this system it is likely the information will be first compressed by a known method, and then encrypted using public-key techniques, before being encoded into the carrier signal.

25 **[0060]** The encoder will also prepare the package of additional information so that it contains an easily recognizable start of message delimiter, which can be unique to each encoding and stored along with the keys, to serve as a synchronization signal to a decoder. The detection of this delimiter in a decoding window signifies that the decoder can be reasonably sure it is aligned to the sample stream correctly and can proceed in a methodic window by window manner. These delimiters will require a number of bits which minimizes the probability that this bit sequence is not reproduced in a random occurrence, causing an accidental misalignment of the decoder. A minimum of 256 bits is recommended. In the current implementation 1024 bits representing a start of message delimiter are used. If each sample is random, then each bit has a 50% probability of matching the delimiter and the conditional probability of a random match would be $1/2^{1024}$. In practice, the samples are probably somewhat less than random, increasing the probability of a match somewhat.

30 **[0061]** The decode process uses the same masks in the same manner, only in this case the information is extracted one bit at a time from the carrier signal.

35 **[0062]** The decoder is assumed to have access to the proper masks used to encode the information originally. These masks might be present in a database, which can be indexed by a value, or values computed from the original content, in a manner insensitive to the modifications to the content caused by the stega-cipher process. So, given an arbitrary piece of content, a decoder might first process the content to generate certain key values, and then retrieve the decode masks associated with the matching key values from the database. In the case where multiple matches occur, or none are found, it is conceivable that all mask sets in the database could be tried sequentially until a valid decode is achieved, or not, indicating no information is present.

40 **[0063]** In the application of this process, it is anticipated that encoding operations may be done on a given piece of content up to 3 times, each adding new information and using new masks, over a sub-segment of the content, and that decode operations will be done infrequently. It is anticipated that should it become necessary to do a search of a large number of masks to find a valid decode, that this process can be optimized using a guessing technique based on close key matching, and that it is not a time critical application, so it will be feasible to test large numbers of potential masks for validity on a given piece of content, even if such a process takes days or weeks on powerful computers to do a

comprehensive search of known mask sets.

[0064] The decode process is slightly different in the following respect. Whereas the encoding process can start at any arbitrary point in the sample stream, the decode process does not know where the encode process began (the exact offset in samples to the start of the first window). Even though the encode process, by convention, starts with sample 0, there is no guarantee that the sample stream has not been edited since encoding, leaving a partial window at the start of the sample stream, and thus requiring the decoder to find the first complete window to start the decode. Therefore, the decode process will start at the first sample, and shift the sample window along by 1 sample, keeping the window index at 0, until it can find a valid decode delimiter encoded in the window. At this point, the decoder knows it has synchronized to the encoder, and can then proceed to process contiguous windows in a more expedient manner.

[0065] Example Calculations based on the described implementation for adding copyright certificate information to CD quality digital audio:

[0066] In a stream of samples, every 128 samples will contain, on average 64 bits of certificate related information. Digital audio is composed of 16 bit samples, at 44.1 KHz, or 44,100 samples per second. Stereo audio provides 2 streams of information at this rate, left and right, or 88,200 samples per second. That yields approximately 689 contiguous sample windows (of 128 samples) per second in which to encode information. Assume a song is 4 minutes long, or 240 seconds. This yields $240 * 689 = 165,360$ windows, which on average (50% utilization) contain 64 bits (8 bytes) each of certificate information. This in turns gives approximately 1291Kb of information storage space per 4 minute stereo song (1.2 MB). There is ample room for redundant encoding of information continuously over the length of the content. Encoding 8 bytes for every 256 bytes represents 3.1% of the signal information. Assuming that a copyright certificate requires at most approximately 2048 bytes (2K), we can encode the same certificate in 645 distinct locations within the recording, or approximately every 37/100ths of a second.

[0067] Now to account for delimiters and synchronization information. Assuming a sync marker of 1024 bits to avoid random matches, then we could prefix each 2K certificate block with this 1024 bit marker. It takes 256 windows to store 2K, and under this proposed scheme, the first 16 windows are reserved for the sync marker. A decoder could search for this marker by progressively matching each of the first 16 windows (64 bits at a time) against the corresponding portion of the sync marker. The decoder could reset the match advancing through the sample stream, as soon as one window did not conform to the sync marker, and proceed in this manner until it matches 16 consecutive windows to the marker, at which point it is synchronized.

[0068] Under this scheme, 240 windows, or 1.92K remain for storing certificate information, which is not unreasonable.

IV. Possible Problems, Attacks and Subsequent Defenses

A. Randomization

[0069] The attacker simply randomizes the least significant bits of each data point in the transform buffer, obliterating the synchronization signal and the watermark. While this attack can remove the watermark, in the context in which steganography is to be used, the problem of piracy is kept to a minimum at least equal to that afforded by traditional media, since the system will not allow an unwatermarked piece of content to be traded for profit and watermarks cannot be forged without the proper keys, which are computationally difficult to obtain by brute-force or cryptanalysis. In addition, if the encoding is managed in such a way as to maximize the level of changes to the sample stream to be just at the threshold below human perception, and the scheme is implemented to anticipate randomization attempts, it is possible to force the randomization level to exceed the level that can be perceived and create destructive artifacts in the signal, in much the same manner as a VHS cassette can be manufactured at a minimal signal level, so that a single copy results in unwatchable static.

B. Low Bit-Depth Bitmaps (black & white images)

[0070] These bitmaps would be too sensitive to the steganization process, resulting in unacceptable signal degradation, and so are not good candidates for the steganography process. The problem may be circumvented by inflating bit-depth, although this is an inefficient use of space and bandwidth.

C. Non-Integer Transforms

[0071] The FFT is used to generate spectral energy information for a given audio signal. This information is not usually in integer format. Computers use methods of approximation in these cases to represent the real numbers (whole numbers plus fractional amounts). Depending on the exact value of the number to be represented slight errors, produced by rounding off the nearest real number that can be completely specified by the computer occur. This will produce some randomization in the least significant bit or bits. In other words, the same operation on the same sample window might

yield slightly different transform values each time. It is possible to circumvent this problem using a modification to the simple LSB steganographic technique described later. Instead of looking at the LSB, the stega-cipher can use an energy quantization technique in place of the LSB method. Some variant of rounding the spectral energy values up or down, with a granularity greater than the rounding error should work, without significantly degrading the output samples.

5

V. A Method and Protocol For Using the Stega-Cipher

[0072] The apparatus described in the claims below operates on a window by window basis over the sample stream. It has no knowledge of the nature of the specific message to be encoded. It merely indexes into a bit stream, and encodes as many of those bits as possible into a given sample window, using a map determined by the given masks.

10

[0073] The value of encoding information into a single window in the sample stream using such an apparatus may not be inherently apparent until one examines the manner in which such information will be used. The protocol discussed in this section details how messages which exceed the encoding capacity of a single sample window (128 samples) may be assembled from smaller pieces encoded in the individual windows and used to defend copyrights in an online situation.

15

[0074] An average of 64 bits can be encoded into each window, which equals only 8 bytes. Messages larger than 8 bytes can be encoded by simply dividing the messages up and encoding small portions into a string of consecutive windows in the sample stream. Since the keys determine exactly how many bits will be encoded per window, and an element of randomness is desirable, as opposed to perfect predictability, one cannot be certain exactly how many bits are encoded into each window.

20

[0075] The start of each message is marked by a special start of message delimiter, which, as discussed above is 1024 bits, or 128 bytes. Therefore, if precisely 8 bytes are encoded per window, the first 16 windows of any useable message in the system described here are reserved for the start of message delimiter. For the encoder, this scheme presents little challenge. It simply designates the first sample window in the stream to be window 0, and proceeds to encode the message delimiter, bit-by-bit into each consecutive window. As soon as it has processed the last bit of the SOM delimiter it continues by encoding 32 bits representing the size, in bytes of the complete message to follow. Once the 32nd and final bit of the size is encoded, the message itself is encoded into each consecutive window, one bit at a time. Some windows may contain more encoded bits than others, as dictated by the masks. As the encoder processes each window in the content it increments its window counter. It uses this counter to index into the window mask. If the number of windows required to encode a complete message is greater than the size of this mask, 256 bits in this case, or 256 windows, then it simply resets the counter after window 255, and so on, until a complete message is encoded. It can then start over, or start on a new message.

25

30

[0076] The decoder has a bigger challenge to face. The decoder is given a set of masks, just like encoder. Unlike the encoder, the decoder cannot be sure that the first series of 128 samples it receives are the window 0 start of message, encoded by the decoder. The sample stream originally produced by an encoder may have been edited by clipping its ends randomly or splicing pieces together. In that case, the particular copy of the message that was clipped is unrecoverable. The decoder has the start of message delimiter used to encode the message that the decoder is looking for. In the initial state, the decoder assumes the first window it gets is window 0. It then decodes the proper number of bits dictated by the masks it was given. It compares these bits to the corresponding bits of the start of message delimiter.

35

If they match, the decoder assumes it is still aligned, increments the window counter and continues. If the bits do not match, the decoder knows it is not aligned. In this case, it shifts one more sample onto the end of the sample buffer, discarding the first sample, and starts over. The window counter is set to 0. The decoder searches one sample at a time for an alignment lock. The decoder proceeds in this manner until it has decoded a complete match to the start of message delimiter or it exhausts the sample stream without decoding a message. If the decoder can match completely the start of message delimiter bit sequence, it switches into aligned mode. The decoder will now advance through the sample stream a full window at a time (128 samples). It proceeds until it has the 32 bits specifying the message size. This generally won't occupy more than 1 complete window. When the decoder has locked onto the start of message delimiter and decoded the message size, it can now proceed to decode as many consecutive additional windows as necessary until it has decoded a complete message. Once it has decoded a complete message, the state of the decoder can be reset to unsynchronized and the entire process can be repeated starting with the next 128 sample window. In this manner it is not absolutely necessary that encoding windows be contiguous in the sample stream. The decoder is capable of handling random intervals between the end of one message and the start of another.

45

50

[0077] It is important to note that the circuit for encoding and decoding a sample window does not need to be aware of the nature of the message, or of any structure beyond the start of message delimiter and message size. It only needs to consider a single sample window, its own state (whether the decoder is misaligned, synchronizing, or synchronized) and what bits to encode/decode.

55

[0078] Given that the stega-cipher apparatus allows for the encoding and decoding of arbitrary messages in this manner, how can it be used to protect copyrights?

[0079] The most important aspect of the stega-cipher in this respect is that fact that it makes the message integral with the content, and difficult to remove. So it cannot be eliminated simply by removing certain information prepended or appended to the sample stream itself. In fact, removing an arbitrary chunk of samples will not generally defeat the stega-cipher either.

5 [0080] Given that some information can be thus integrated with the content itself, the question is then how best to take advantage of this arrangement in order to protect copyrights.

[0081] The following protocol details how the stega-cipher will be exploited to protect copyrights in the digital domain.

[0082] In a transaction involving the transfer of digitized content, there are at least 3 functions involved:

10 [0083] The Authority is a trusted arbitrator between the two other functions listed below, representing parties who actually engage in the transfer of the content. The Authority maintains a database containing information on the particular piece of content itself and who the two parties engaged in transferring the content are. The Authority can perform stega-cipher encoding and decoding on content.

[0084] The Publisher, or online distributor is the entity which is sending the copyrighted content to another party. The Publisher can perform stega-cipher encoding and decoding on content.

15 [0085] The Consumer is the person or entity receiving the copyrighted content, generally in exchange for some consideration such as money. The consumer cannot generally perform stega-cipher encoding or decoding on content.

[0086] Each of these parties can participate in a message exchange protocol using well known public-key cryptographic techniques. For instance, a system licensing RSA public key algorithms might be used for signed and encrypted message exchange. This means that each party maintains a public key / private key pair, and that the public keys of each party are freely available to any other party. Generally, the Authority communicates via electronic links directly only to the Publisher and the Consumer communicates directly only with the publisher.

20 [0087] Below is an example of how the protocol operates from the time a piece of content enters an electronic distribution system to the time it is delivered to a Consumer.

[0088] A copyright holder (an independent artist, music publisher, movie studio, etc.) wishes to retail a particular title online. For instance, Sire Records Company might wish to distribute the latest single from Seal, one of their musical artists, online. Sire delivers a master copy of this single, "Prayer for the Dying", to the Authority, Ethical Inc. Ethical converts the title into a format suitable for electronic distribution. This may involve digitizing an analog recording. The title has now become content in the context of this online distribution system. The title is not yet available to anyone except Ethical Inc., and has not yet been encoded with the stega-cipher watermark. Ethical generates a Title Identification and Authentication (TIA) certificate. The certificate could be in any format. In this example it is a short text file, readable with a small word-processing program, which contains information identifying

25
30
35 the title
the artist
the copyright holder
the body to which royalties should be paid
general terms for publishers' distribution
any other information helpful in identifying this content

40 [0089] Ethical then signs the TIA with its own private key, and encrypts the TIA certificate plus its signature with its own public key. Thus, the Ethical can decrypt the TIA certificate at a later time and know that it generated the message and that the contents of the message have not been changed since generation.

[0090] Sire Records, which ultimately controls distribution of the content, communicates to the Ethical a specific online Publisher that is to have the right of distribution of this content. For instance, Joe's Online Emporium. The Authority, Ethical Inc. can transmit a short agreement, the Distribution Agreement to the Publisher, Joe's Online Emporium which lists

45
50 the content title
the publisher's identification
the terms of distribution
any consideration paid for the right to distribute the content
a brief statement of agreement with all terms listed above

55 [0091] The Publisher receives this agreement, and signs it using its private key. Thus, any party with access to the Joe's Online Emporium's public key could verify that the Joe's signed the agreement, and that the agreement has not been changed since Joe's signed it. The Publisher transmits the signed Distribution Agreement to the Authority, Ethical Inc.

[0092] Ethical Inc. now combines the signed TIA certificate and the Distribution Agreement into a single message, and signs the entire message using its private key. Ethical has now created a Publisher Identification message to go

into its own stega-cipher channel in the content. Ethical Inc. now generates new stega-cipher masks and encodes this message into a copy of the content using a stega-cipher encoder. The Authority saves the masks as a Receipt in a database, along with information on the details of the transfer, including the title, artist and publisher.

5 [0093] Ethical then transfers this watermarked copy to the Joe's Online Emporium, the Publisher. Well known encryption methods could be used to protect the transfer between the Authority and the Publisher. The Authority may now destroy its copy, which the Publisher has received. The Publisher, Joe's Online Emporium now assumes responsibility for any copies made to its version of the content, which is a Publisher Master copy.

10 [0094] Finally, the Consumer, John Q. Public wishes to purchase a copy of the content from Joe's Online Emporium. Joe's Emporium sends the John Q. Public a short agreement via an electronic communication link, similar to Publisher's Distribution Agreement, only this is a Purchase Agreement, which lists

- the content title
- consumer identification
- the terms of distribution
- 15 the consideration pas for the content
- a brief statement of agreement with the terms above

[0095] John Q. Public signs this agreement with his private key and returns it to the Joe's Online Emporium. The Publisher, Joe's prepares to encode its own stega-cipher watermark onto a copy of the content by generating a set of masks for the algorithm. Joe's Online Emporium then stores these masks (a receipt) in its own database, indexed by title and consumer. Joe's Online Emporium signs the agreement received from John Q. Public with the Emporium's own private key, and forwards it to the Authority, Ethical Inc., along with a copy of the masks. It is important to note that this communication should be done over a secured channel. The Authority verifies the Publisher and Consumer information and adds its own signature to the end of the message, approving the transaction, creating a Contract of Sale. The Authority adds the Publisher's receipt (mask set) to its database, indexed by the title, the publisher, and the consumer identification. The Authority signs the Contract of Sale by encrypting it with their private key. So anyone with the Authority's public key (any Publisher) could decrypt the Contract of Sale and verify it, once it was extracted from the content. The Publisher then transmits the signed Contract of Sale back to the Publisher, who uses a stega-cipher device to imprint this Contract as its own watermark over the content. The Publisher then transmits the newly watermarked copy to the Consumer, who is accepting responsibility for it. The Publisher destroys their version of the consumer's copy.

30 [0096] If this procedure is followed for all content distribution within such an online system then it should be possible for the Authority to identify the owner of a piece of content which appears to be unauthorized. The Authority could simply try its database of stega-cipher keys to decode the watermark in the content in question. For instance, if a copy of Seal's latest single originally distributed with stega-cipher watermarks showed up on an Internet ftp site the Authority should be able to extract a TIA Certificate and Distribution Agreement or a Contract of Sale identifying the responsible party. If a Publisher sold this particular copy to a Consumer, that particular publisher should be able to extract a Contract of Sale, which places responsibility with the Consumer. This is not a time critical application, so even if it takes days or weeks, it is still worthwhile.

40 [0097] In a modification to the protocol discussed above, each Publisher might act as its own Authority. However, in the context of online services, this could open avenues of fraud committed by the collusion of certain Publishers and Consumers. Using an Authority, or one of several available Authorities to keep records of Publisher-Consumer transactions and verify their details decreases the likelihood of such events.

45 [0098] It should also be obvious that a similar watermarking system could be used by an individual entity to watermark its own content for its own purposes, wether online or in physical media. For instance, a CD manufacturer could incorporate unique stega-cipher watermarks into specific batches of its compact discs to identify the source of a pirate ring, or to identify unauthorized digital copies made from its discs. This is possible because the stega-cipher encoding works with the existing formats of digital samples and does not add any new structures to the sample data that cannot be handled on electronic or mechanical systems which predate the stega-cipher.

50 **VI. Increasing Confidence in the Stega-Cipher**

[0099] The addition of a special pre-encoding process can make stega-cipher certificates even more secure and undeniable. Hash values may be incorporated which match exactly the content containing the watermark to the message in the watermark itself. This allows us a verification that the watermark decoded was encoded by whomever signed it into this precise location in this specific content.

55 [0100] Suppose one wants to use a 256 bit (32 byte) hash value which is calculated with a secure one-way hash function over each sample in each sample window that will contain the message. The hash starts with a seed value, and each sample that would be processed by the encoder when encoding the message is incorporated into the hash

EP 0 872 073 B1

as it is processed. The result is a 256 bit number one can be highly confident is unique, or sufficiently rare to make intentionally duplicating it with another series of samples difficult.

[0101] It is important that the hash function be insensitive to any changes in the samples induced by the stega-cipher itself. For instance, one might ignore the least significant bit of each sample when computing the hash function, if the stega-cipher was implemented using a least significant bit encode mode.

[0102] Based on the size of the non-hash message, one knows the hash-inclusive message requires 32 more bytes of space. One can now calculate the size of a signed encrypted copy of this message by signing and encrypting exactly as many random bytes as are in the message, and measuring the size of the output in bytes. One now knows the size of the message to be encoded. One can pre-process the sample stream as follows.

[0103] Proceed through the stega-cipher encode loop as described in the claims. Instead of encoding, however, calculate hash values for each window series which will contain the message, as each sample is processed. At the end of each instance of "encoding" take the resultant hash value and use it to create a unique copy of the message which includes the hash value particular to the series of sample windows that will be used to encode the message. Sign and encrypt this copy of the message, and save it for encoding in the same place in the sample stream.

[0104] A memory efficient version of this scheme could keep on hand the un-hashed message, and as it creates each new copy, back up in the sample stream to the first window in the series and actually encode each message, disposing of it afterwards.

[0105] The important result is evident on decoding. The decoding party can calculate the same hash used to encode the message for themselves, but on the encoded samples. If the value calculated by the decoding party does not match the value contained in the signed message, the decoder is alerted to the fact that this watermark was transplanted from somewhere else. This is possible only with a hash function which ignores the changes made by the stega-cipher after the hash in the watermark was generated.

[0106] This scheme makes it impossible to transplant watermarks, even with the keys to the stega-cipher.

Appendix - Pseudo-code

[0107]

```
const int WINDOW_RESET = 256;
const int WINDOW_SIZE = 128;
const int MARKER_BITS = 1024;
const int CHUNK_BITS = 2048 * 8;

int window_offset;
int msg_bit_offset;
int frequency_offset;
Boolean useCell;

/* 8 bits per byte, 1 byte per char */
unsigned char frequency_mask[WINDOW_SIZE/8];
unsigned char window_mask[WINDOW_RESET/8];
unsigned char msg_start_marker[MARKER_BITS/8];
unsigned char msg_end_marker[MARKER_BITS/8];
Int16 amplitude_sample_buffer[WINDOW_SIZE];
float power_frequency_buffer[WINDOW_SIZE];
unsigned char message_buffer[CHUNK_BITS/8];

void doFFT(Int16 *amp_sample_buffer, float *power_freq_buffer, int size);
void doInverseFFT(Int16 *amp_sample_buffer, float *power_freq_buffer, int size);
void initialize();
Bit getBit(unsigned char *buffer, int bitOffset);
Boolean map(Bit window_bit, Bit band_bit, int window, int frequency);
Boolean getSamples(Int16 *amplitude_sample_buffer, int samples);
void encode()

void initialize()
{
    /* message to be encoded is generated */
    /* message is prefixed with 1024 bit msg_start_marker */
    /* message is suffixed with 1024 bit msg_end _marker */
```

EP 0 872 073 B1

```
/* remaining space at end of message buffer padded with random bits */
window_offset = 0;
msg_bit_offset = 0;
frequency_offset = 0;
5   frequency_mask loaded
   window_mask loaded
   zeroAmpSampleBuffer();
}

Boolean getSamples(Int16 *buffer,int samples)
10  {
    /* get samples number of samples and shift them contiguously into the sample
       buffer from right to left*/
    if(samples < samples available)
        return false;
15  else
        return true;
}

void doFFT(Int16 *sample_buffer, float *spectrum_buffer, int size)
20  {
    calculate FFT on sample_buffer, for size samples
    store result in spectrum buffer
}

void doInverseFFT(Int16 *sample_buffer,float *spectrum_buffer,int size)
25  {
    calculate inverse FFT on spectrum_buffer
    store result in sampe_buffer
}

Bit getBit(unsigned char *buffer in bitOffset)
30  {
    returns value of specified bit in specified buffer
    either 0 or 1, could use Boolean (true/false) values for bit set of bit off
}

Boolean map(Bit window_bit.Bit band_bit,int window, int frequency)
35  {
    /* this is the function that makes the information difficult to find */
    /* the inputs window_bit and band_bit depend only on the mask values
       used for encoding the information, they are 1) random, 2) secret */
40  /* window and frequency values are used add time and frequency band dependent
       complexity to this function */
    /* this function is equivalent to a Boolean truth table with window* frequency 4
       possible input combinations and 2 possible output*/
    /* for any input combination, the output is either true or false */
    /* window ranges from 0 to WINDOW_RESET -1 */
45  /* frequency ranges from 0 to WINDOW_SIZE -1 */
    return calculated truth value
}

void encodeBit(float *spectrum_buffer,int freq_offset,Bit theBit)
50  {
    /* modifies the value of the cell in spectrum_buffer, indexed by freq_offset
       in a manner that distinguishes each of the 2 possible values of theBit,
       1 or 0
    */
    /* suggested method of setting the Least Significant bit of the cell == theBit */
55  /* alternative method of rounding the value of the cell upward or downward to
       certain fractional values proposed
       i.e. <= .5 fractional remainder signifies 0, > .5 fraction remainder
       signifies 1
```

EP 0 872 073 B1

```

        */
    }

void encode()
5  {
    initialize();

    do {
        if(getSamples(amplitude_sample_buffer) == false)
10         return

        doFFT(amplitude_sample_buffer, power_frequency_buffer, WINDOW_SIZE);

        for (frequency_offset = 0; frequency_offset < WINDOW_SIZE;
            frequency_offset++){
15

            useCell = map(getBit(window_mask, window_offset),
                getBit(frequency_mask, frequency_offset),
                window_offset, frequency_offset);

            if(useCell == true) {
20                encodeBit(power_frequency_buffer, frequency_offset,
                    getBit(message_buffer, msg_bit_offset));
                message_bit_offset ++;
                if(msg_bit_offset == MESSAGEBITS){
                    initialize();
25                    break; /* exit frequency loop */
                }
            }
        }
        doInverseFFT(amplitude_sample_buffer, power_frequency_buffer,
30            WINDOW_SIZE);

        outputSamples(amplitude_sample_buffer);

        window_offset++;
        if(window_offset==WINDOW_RESET){
35            window_offset = 0;
        }

    }while(true);
}

```

40 **[0108]** The encode() procedure processes an input sample stream using the specified frequency and window masks as well as a pre-formatted message to encode.

[0109] encode() processes the sample stream in windows of WINDOW_SIZE samples, contiguously distributed in the sample stream, so it advances WINDOW_SIZE samples at a time.

45 **[0110]** For each sample window, encode() first compute the FFT of the window, yielding its Power Spectrum Estimation. For each of these window PSEs, encode() then uses the map() function to determine where in each PSE to encode the bits of the message, which it reads from the message buffer, one bit at a time. Each time map() returns true, encode() consumes another sample from the message.

50 **[0111]** After each window is encoded, encode() computes the inverse FFT on the PSE to generate a modified sample window, which is then output as the modified signal. It is important the sample windows NOT overlap in the sample stream, since this would potentially damage the preceding encoding windows in the stream.

[0112] Once the message is entirely encoded, including its special end of message marker bit stream, encode() resets its internal variables to begin encoding the message once more in the next window, encode() proceeds in this manner until the input sample stream is exhausted.

```

55  enum {
        Synchronizing,
        Locked
    }

```

EP 0 872 073 B1

```

} ; /* decode states */
unsigned char message_end_buffer[MARKER_BITS];

Bit decodeBit(float *spectrum_buffer,int freq_offset)
5 {
    /* reads the value of the cell in spectrum_buffer, indexed by freq_offset
       in a manner that distinguishes each of the 2 possible values of an
       encoded bit, 1 or 0
    */
    /* suggested method of testing the Least Significant bit of the cell */
10 /* alternative method of checking the value of the cell versus certain fractional
    remainders proposed.
       i.e. <= .5 fractional remainder signifies 0, > .5 fraction remainder
       signifies 1
    */
15 return either 1 or 0 as appropriate
}

Boolean decode()
{
20 /* Initialization */
state = Synchronizing
window_offset = 0;
set frequency mask
set window mask
clear sample buffer
25 int nextSamples = 1;
int msg_start_offset = 0;
clear message_end_buffer
Bit aBit;
Boolean bitsEqual;
do {
30
    if(state == Synchronizing){
        nextSamples= 1;
        window_offset = 0;
    }
35 else
        nextSamples = WINDOW_SIZE;

    if(getSamples(amplitude_sample_buffer) == false)
        return false;
40 doFFT(amplitude_sample_buffer,power_frequency_buffer,
        WINDOW_SIZE); /*2*/

    for (frequency_offset = 0; frequency_offset < WINDOW_SIZE;
        frequency_offset++){
45
        useCell = map(getBit(window_mask,window_offset),
            getBit(frequency_mask,frequency_offset),
            window_offset, frequency_offset);

        if(useCell == true){
50 aBit = decodeBit(power_frequency_buffer,
            frequency_offset);
            setBit(message_buffer,message_bit_offset,aBit),
            message_bit_offset ++;
        }
        else
55 continue;
    if(state == Synchronizing) {
        bitsEqual =
            compareBits(message_start_marker,message_buffer,

```

EP 0 872 073 B1

```
message_bit_offset);
if(!bitsEqual){
    message_bit_offset = 0;
    misaligned = true;
    break; /* exit frequency loop */
}
else if(message_bit_offset == MARKER_BITS)
    state = Locked;
}
else {
    /* locked onto encoded stream */
    shift aBit into right side of message_end_buffer
    bitsEqual = compareBits(message_end_buffer,
        msg_end_marker MARKER_BITS);
    if(bitsEqual)
        return true;
}
} while (true);
}
```

20 **[0113]** The decode() procedure scans an input sample stream using specified window and frequency masks, until it either decodes a valid message block, storing it in a message buffer, or exhausts the sample stream.

25 **[0114]** The decode() procedure starts in state Synchronizing, in which it does not know where in the sample stream the encoding windows are aligned. The procedure advances the sample window through the sample stream one sample at a time, performing the FFT calculation on each window, and attempting to decode valid message bits from the window. As it extracts each bit using the map() function, the decode() procedure compares these bits against the start of message marker. As soon as a mismatch is detected, the decode() procedure knows it is not yet properly aligned to an encoding window, and immediately ceases decoding bits from the current window and moves to the next window, offset by 1 sample. The decode() procedure continues in this manner until it matches successfully the complete bitstream of a start of message marker. At this point the decode() procedure assumes it is aligned to an encoded message and can then decode bits to the message buffer quickly, advancing the sample window fully at each iterations. It is now in Locked mode. For each bit it stores in the message buffer when in Locked mode, the decode() procedure also shifts the same bit value into the least significant bit of the message_end_buffer. After each bit is decoded in Locked mode, the decode() procedure checks compares the message_end_buffer with the msg_end_marker in a bit by bit manner. When a complete match is found, decode() is finished and returns true. If the sample stream is exhausted before this occurs, decode() returns false. If decode() returns true, a valid message is stored in the message buffer, including the start and end of message markers.

40 Claims

1. A method for identifying content with a steganographic cipher process, said process using a steganographic technique of hiding additional information including a watermark in combination with a cryptographic technique of multiple keys, comprising the steps of:
 - 45 a) receiving content that has been steganographically encoded with additional information for identifying the content, wherein the encoding is controlled using at least one of the multiple keys;
 - b) acquiring at least one of the multiple keys to be used for decoding;
 - c) using the steganographic cipher process to locate the additional information by using the at least one of the acquired keys;
 - 50 d) using the steganographic cipher process to extract the located additional information from the content.
2. The method according to claim 1, wherein the additional information includes at least one selected from the group consisting of: the title of the encoded content, the artist of the encoded content, terms of distribution of the encoded content, rights ownership identification, authorship identification of the content, publication rights of the encoded content, ownership identification of the encoded content, and an audit trail of the encoded content.
- 55 3. The method according to claim 1, wherein the additional information includes at least one selected from the group

consisting of: information for enabling use of the encoded content, meterware information for the use of the encoded content, pay-by-use information for the use of the encoded content, and payment information for access to the encoded content.

5 4. The method according to claim 1 wherein the additional information is encoded in at least two locations of the content; and the method further comprising the step of:

e) using said steganographic cipher process to locate and extract said additional information from at least one of the two locations of the content.

10 5. The method according to claim 1, wherein said additional information does not perceptibly affect the encoded content.

6. The method according to claim 5, wherein the encoded content comprises at least one selected from the following group consisting of: an analog waveform, a digital sample stream, and a compressed copy of the encoded content.

15 7. The method according to claim 1 wherein the watermark includes an encode hash of at least a portion of the content and wherein the method comprises the step of e) generating a decode hash of at least a portion of the content and comparing said encode hash to said decode hash.

20 8. The method according to claim 1 wherein:

the watermark includes an encode hash of at least a portion of the content that contains the watermark, wherein the encode hash is insensitive to encoding the watermark into the content and further generating a decode hash of at least a portion of the content that contains the watermark and comparing said encode hash to said decode hash.

25 9. The method according to claim 1 wherein:

the additional information contains a signed or encrypted watermark that is insensitive to said steganographic encoding process.

30

Patentansprüche

35 1. Verfahren zum Identifizieren von Inhalt durch einen steganografischen Verschlüsselungsprozess, in dem eine Steganografiertechnik zum Verbergen von Zusatzinformation, die ein digitales Wasserzeichen enthält, in Kombination mit einer Kryptografiertechnik mit mehreren Schlüsseln verwendet wird, wobei das Verfahren die Schritte aufweist:

a) Empfangen von Inhalt, der steganografisch mit Zusatzinformation zum Identifizieren des Inhalts codiert worden ist, wobei die Codierung unter Verwendung mindestens eines der mehreren Schlüssel gesteuert wird;

40 b) Erfassen mindestens eines der mehreren Schlüssel für eine Decodierung;

c) Verwenden des steganografischen Verschlüsselungsprozesses zum Lokalisieren der Zusatzinformation unter Verwendung des mindestens einen erfassten Schlüssels;

45 d) Verwenden des steganografischen Verschlüsselungsprozesses zum Extrahieren der lokalisierten Zusatzinformation vom Inhalt.

2. Verfahren nach Anspruch 1, wobei die Zusatzinformation mindestens eines der folgenden Elemente aufweist: den Titel des codierten Inhalts, den Verfasser des codierten Inhalts, Verteilungsregeln des codierten Inhalts, eine Rechteinhaberschaftidentifizierung, eine Urheberschaftidentifizierung des Inhalts, Publikationsrechte des codierten Inhalts, eine Eigentumsrechtidentifizierung des codierten Inhalts und den Prüfpfad oder Audit Trail des codierten Inhalts.

50 3. Verfahren nach Anspruch 1, wobei die Zusatzinformation mindestens eines der folgenden Elemente aufweist: Information für die Freigabe der Nutzung des codierten Inhalts, Zählwert-Information für die Verwendung des codierten Inhalts; Information über Zahlungen für die Verwendung des codierten Inhalts und Zahlungsinformation für einen Zugriff auf die codierte Information.

4. Verfahren nach Anspruch 1, wobei die Zusatzinformation an mindestens zwei Stellen des Inhalts codiert ist; und

EP 0 872 073 B1

wobei das Verfahren ferner den Schritt aufweist:

e) Verwenden des steganografischen Verschlüsselungsprozesses zum Lokalisieren und Extrahieren der Zusatzinformation von mindestens einer der beiden Stellen des Inhalts.

5

5. Verfahren nach Anspruch 1, wobei die Zusatzinformation den codierten Inhalt nicht wahrnehmbar beeinflusst.
6. Verfahren nach Anspruch 5, wobei der codierte Inhalt mindestens eines der Elemente aufweist: eine analoge Wellenform, einen digitalisierten Datenstrom und eine komprimierte Kopie des codierten Inhalts.
7. Verfahren nach Anspruch 1, wobei das Wasserzeichen eine Codierungs-Prüfung mindestens eines Teils des Inhalts aufweist, und wobei das Verfahren den Schritt e) zum Erzeugen einer Decodierungs-Prüfung mindestens eines Teils des Inhalts und Vergleichen der Codierungs-Prüfung mit der Decodierungs-Prüfung aufweist.
8. Verfahren nach Anspruch 1, wobei das Wasserzeichen eine Codierungs-Prüfung mindestens eines Teils des Inhalts aufweist, der das Wasserzeichen enthält, wobei die Codierungs-Prüfung bezüglich der Codierung des Wasserzeichens in den Inhalt unempfindlich ist, und wobei das Verfahren ferner die Schritte zum Erzeugen einer Decodierungs-Prüfung mindestens eines Teils des Inhalts, der das Wasserzeichen enthält, und das Vergleichen der Codierungs-Prüfung mit der Decodierungs-Prüfung aufweist.
9. Verfahren nach Anspruch 1, wobei die Zusatzinformation ein signiertes oder verschlüsseltes Wasserzeichen enthält, das bezüglich des steganografischen Codierprozesses unempfindlich ist.

10

15

20

25

Revendications

1. Un procédé pour identifier un contenu avec un processus de chiffrement stéganographique, ce processus utilisant une technique stéganographique pour cacher de l'information supplémentaire incluant un filigrane numérique en combinaison avec une technique cryptographique à clés multiples, comprenant les étapes suivantes :

30

- a) recevoir un contenu qui a été codé de façon stéganographique avec une information supplémentaire pour identifier le contenu, le codage étant commandé en utilisant au moins une des clés multiples;
- b) acquérir au moins une des clés multiples à utiliser pour le décodage;
- c) utiliser le processus de chiffrement stéganographique pour localiser l'information supplémentaire en utilisant l'au moins une des clés acquises;
- d) utiliser le processus de chiffrement stéganographique pour extraire du contenu l'information supplémentaire localisée.

35

40

2. Le procédé selon la revendication 1, dans lequel l'information supplémentaire comprend au moins une information sélectionnée dans le groupe comprenant : le titre du contenu codé, l'artiste du contenu codé, des conditions de distribution du contenu codé, une identification de propriété de droits, une identification d'auteur du contenu, des droits de publication du contenu codé, une identification de propriété du contenu codé, et une trace de contrôle du contenu codé.

45

3. Le procédé selon la revendication 1, dans lequel l'information supplémentaire comprend au moins une information sélectionnée dans le groupe comprenant : une information pour permettre l'utilisation du contenu codé, une information de compteur pour l'utilisation du contenu, codé, une information de paiement en fonction de l'utilisation pour l'utilisation du contenu codé, et une information de paiement pour l'accès au contenu codé.

50

4. Le procédé selon la revendication 1, dans lequel l'information supplémentaire est codée dans au moins deux emplacements du contenu; et le procédé comprenant en outre l'étape suivante :

55

e) utiliser le processus de chiffrement stéganographique pour localiser et extraire l'information supplémentaire à partir d'au moins un des deux emplacements du contenu.

5. Le procédé selon la revendication 1, dans lequel l'information supplémentaire n'affecte pas de façon perceptible le contenu codé.

EP 0 872 073 B1

6. Le procédé selon la revendication 5, dans lequel le contenu codé comprend au moins un contenu sélectionné dans le groupe suivant consistant en : une forme d'onde analogique, un train d'échantillons numériques, et une copie compressée du contenu codé.
- 5 7. Le procédé selon la revendication 1, dans lequel le filigrane numérique comprend une valeur de hachage de codage d'au moins une partie du contenu, et dans lequel le procédé comprend l'étape suivante:
- 10 e) générer une valeur de hachage de décodage d'au moins une partie du contenu et comparer la valeur de hachage de codage avec la valeur de hachage de décodage.
- 15 8. Le procédé selon la revendication 1, dans lequel:
- le filigrane numérique comprend une valeur de hachage de codage d'au moins une partie du contenu qui contient le filigrane numérique, dans lequel la valeur de hachage de codage est insensible au codage du filigrane numérique dans le contenu, et on génère en outre une valeur de hachage de décodage d'au moins une partie du contenu qui contient le filigrane numérique et on compare la valeur de hachage de codage avec la valeur de hachage de décodage.
- 20 9. Le procédé selon la revendication 1, dans lequel l'information supplémentaire contient un filigrane numérique signé ou chiffré qui est insensible au processus de codage stéganographique.

25

30

35

40

45

50

55

EP 0 872 073 B1

REFERENCES CITED IN THE DESCRIPTION

This list of references cited by the applicant is for the reader's convenience only. It does not form part of the European patent document. Even though great care has been taken in compiling the references, errors or omissions cannot be excluded and the EPO disclaims all liability in this regard.

Patent documents cited in the description

- EP 0581317 A [0019]
- WO 4979210 A, Nagata [0049]
- WO 5073925 A [0049]

Non-patent literature cited in the description

- **BENDER W. et al.** Proceedings of the SPIE. *SPIE, Bellingham, VA, US*, 09 February 1995, vol. 2420, 164-173 [0020]



INTERNATIONAL APPLICATION PUBLISHED UNDER THE PATENT COOPERATION TREATY (PCT)

<p>(51) International Patent Classification ⁶ : H04B 13/00, H04J 3/26, H04L 12/40</p>	<p>A1</p>	<p>(11) International Publication Number: WO 97/01892 (43) International Publication Date: 16 January 1997 (16.01.97)</p>
<p>(21) International Application Number: PCT/US95/08159 (22) International Filing Date: 26 June 1995 (26.06.95) (60) Parent Application or Grant (63) Related by Continuation US 08/083,593 (CIP) Filed on 30 June 1993 (30.06.93) (71)(72) Applicant and Inventor: MOSKOWITZ, Scott, A. [US/US]; 20191 E. Country Club Drive, North Miami Beach, FL 33180 (US). (74) Agents: ALTMILLER, John, C. et al.; Kenyon & Kenyon, 1025 Connecticut Avenue, N.W., Washington, DC 20036 (US).</p>	<p>(81) Designated States: CA, CN, JP, KR, SG, US, European patent (AT, BE, CH, DE, DK, ES, FR, GB, GR, IE, IT, LU, MC, NL, PT, SE). Published <i>With international search report.</i></p>	

(54) Title: DIGITAL INFORMATION COMMODITIES EXCHANGE WITH VIRTUAL MENUING

(57) Abstract

A system for the exchange of digital information packets includes an exchange (1) with connectors to allow modular expandable units (11-15) to connect to the exchange over transmission media (5). The modular expandable units (11-15) send digital information packets from one to another over the exchange (1) in response to requests for these digital information packets. The exchange (1) allows for billing and other administrative functions. A virtual menuing system is disclosed for use with the exchange (1) allowing a simple choice of digital information packets to be published and/or subscribed to.

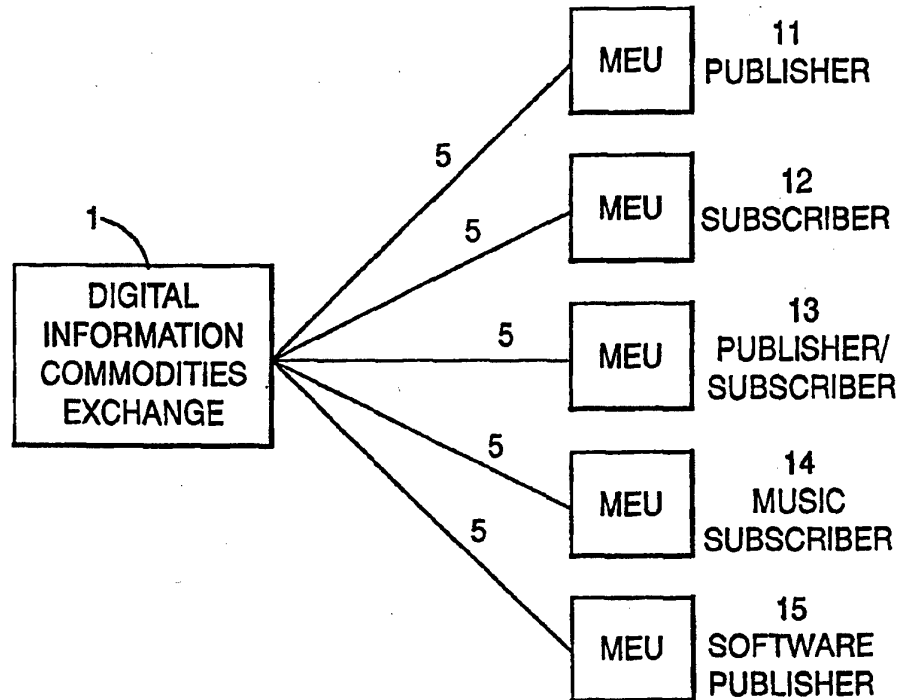

FOR THE PURPOSES OF INFORMATION ONLY

Codes used to identify States party to the PCT on the front pages of pamphlets publishing international applications under the PCT.

AM	Armenia	GB	United Kingdom	MW	Malawi
AT	Austria	GE	Georgia	MX	Mexico
AU	Australia	GN	Guinea	NE	Niger
BB	Barbados	GR	Greece	NL	Netherlands
BE	Belgium	HU	Hungary	NO	Norway
BF	Burkina Faso	IE	Ireland	NZ	New Zealand
BG	Bulgaria	IT	Italy	PL	Poland
BJ	Benin	JP	Japan	PT	Portugal
BR	Brazil	KE	Kenya	RO	Romania
BY	Belarus	KG	Kyrgyzstan	RU	Russian Federation
CA	Canada	KP	Democratic People's Republic of Korea	SD	Sudan
CF	Central African Republic	KR	Republic of Korea	SE	Sweden
CG	Congo	KZ	Kazakhstan	SG	Singapore
CH	Switzerland	LI	Liechtenstein	SI	Slovenia
CI	Côte d'Ivoire	LK	Sri Lanka	SK	Slovakia
CM	Cameroon	LR	Liberia	SN	Senegal
CN	China	LT	Lithuania	SZ	Swaziland
CS	Czechoslovakia	LU	Luxembourg	TD	Chad
CZ	Czech Republic	LV	Latvia	TG	Togo
DE	Germany	MC	Monaco	TJ	Tajikistan
DK	Denmark	MD	Republic of Moldova	TT	Trinidad and Tobago
EE	Estonia	MG	Madagascar	UA	Ukraine
ES	Spain	ML	Mali	UG	Uganda
FI	Finland	MN	Mongolia	US	United States of America
FR	France	MR	Mauritania	UZ	Uzbekistan
GA	Gabon			VN	Viet Nam

**DIGITAL INFORMATION COMMODITIES EXCHANGE
WITH VIRTUAL MENUING**

FIELD OF THE INVENTION

5 The present invention relates generally to an information network and menuing system, and more particularly to a digital information exchange system (DICE) where users can send and receive multiple types of data with a virtual menu.

10 BACKGROUND OF THE INVENTION

 A multitude of electronic bulletin boards are in use today. Such bulletin boards generally consist of a particular type of data and are geared to a particular market. Generally, a subscriber has an interest in a
15 particular subject, connects to a bulletin board corresponding to that subject, and retrieves information from it. Occasionally a subscriber may leave information on a bulletin board, either for use by another subscriber or to an administrator of the board. Generally, the flow
20 of information is downstream, i.e., from the board to the subscriber.

 For the purpose of this discussion, a person is referred to as subscriber if they are receiving information. A person or entity who is supplying
25 information is referred to as a publisher.

 The current paradigm under which these bulletin board systems operate requires that a subscriber own a computer system with which to connect to the bulletin

board. Such a computer system usually requires a CPU, a keyboard, and a CRT or other display device. A subscriber generally "downloads" information from the on-line system's service to his or her private computer system. The information is generally usable only within the context of the computer system. Examples of such information include executable computer software (particular to certain types of computers) and data files that are understood by programs which run on the subscriber's computer and which contain information (e.g., a graphical image or sound clip). It is very difficult, at best, for a subscriber to use the information received from the on-line system outside of the bounds of a computer system.

Different commercial embodiments of electronic bulletin boards vary in the types of digital data used. However, they are similar in the direction of the flow of data. For example, the Prodigy® and CompuServe® systems are popular news and entertainment services. With the exception of their electronic mail, shopping, and billing, the flow of information is towards the subscriber. Similarly, the Audio Archive in Syracuse, New York, provides hundreds of thousands of downloadable audio recordings to subscribers. The only information sent upstream by the subscriber to the Archive is the choice of recording.

Under present distribution systems, such as cable TV networks, downstream flow is the norm. A cable subscriber is simply presently incapable of sending the same type and quantity of data in the reverse direction. At best, current interactive cable systems in testing stages allow for a minimal backchannel to allow subscribers to send selection data to a collection or centrally located video server device. With on-line services such as CompuServe®, the parties involved in the transaction are forced to store their data on

Compuserve®'s computers. If Compuserve® computers went off-line, so would all of its subscribers.

There are also a number of prior art patents disclosing such a downstream, unidirectional flow of data, e.g., U.S. Patent No. 5,132,992 to Yurt et al., U.S. Patent No. 4,326,289 to Dickinson, and U.S. Patent No. 4,491,983 to Pinnow.

The above systems demonstrate a basic limitation of the traditional digital communications system, namely, the subscriber is limited to a particular library and is limited to a particular data type. In addition, the subscriber must access a library with a particular device such as a computer, or with a subscriber interface module (SIM).

There is a need for a system in which a vast number of participants can act as providers as well as consumers of data, in the manner of a commodities exchange. Such a system would give rise to a much larger number of producers of data than is presently available. This could ultimately provide a wider range of information topics available to information seekers and would provide more of an information marketplace.

It would also be desirable and possible to provide data for almost any and every interest. In essence, one could provide a multimedia system in which all types of digital data (music, text, moving video, virtual reality, etc.) could be published and subsequently subscribed to by consumers using their information or entertainment system, and which could be expanded to adapt to different data types thereby further expanding the digital information marketplace.

Such a system would be modular and provide that the failure of any one unit would not preclude other subscribers from making use of the system.

Three problems, at least, are addressed:

1. The difficulty encountered by individual subscribers who wish to publish data, whether for

commercial or private purposes, which are in part caused by the paradigm of archive/download and implemented in hub-oriented networks.

2. The limitation imposed by current systems wherein data addressed via the system is useless (digitally) outside the system and/or SIM, either because it has no meaning or because it cannot be easily transferred out.

3. The slowness of data transfer across only one transmission line. In particular, transmission times are made faster by using parallel transmission techniques across distinct transmission media.

The invention as disclosed and claimed further includes details of the specific processing method for implementing an information service menu (for computers and other similar devices) between the host device and a remote client device connected by an arbitrary telecommunications link.

The use of the disclosed menu invention represents an improvement in the art in, e.g., the specific areas of efficiency of transmission and flexibility of presentation.

The current state of the art in computer systems and telecommunications technology includes rapidly proliferating on-line services, remote operation and navigation of information systems, to provide a remote host or server which communicates via telecommunication lines with various clients. One aspect of such systems, from modern graphical interfaces to ASCII-only technologies, is the use of menus to facilitate interaction between the host and the users of the client machines. Typically, a menu has a list of items, characterized by an ASCII text label for each, which provides an intuitive description of the choices available to a user. The selection of such an item, which may be associated with a fixed numeral to provide a shorthand method of identifying it, is communicated

from the client to the host which then causes some action associated with the item in question to take place. In the context of a graphical user interface, such as Windows or the Macintosh OS, various embellishments such as special fonts or icons may be added to the presentation of such menus, and the display of the menu as a whole may be packaged into some graphical enclosure construct in order to separate menu items from surrounding information.

Menus can furthermore be hierarchical. That is, they may contain items which themselves represent submenus.

A typical example of such a menuing system is that used by the on-line service America On-Line (AOL). AOL has two basic types of menus. In particular, AOL presents various screens having several icons (graphical devices used in place of traditional text labels). To select an item, the user clicks on an icon with a graphical pointing device such as a mouse. Although this looks much different from a traditional text based menu, it implements the same function. By clicking on the various icons, the user can navigate to various content-specific areas of the host information system in a trigger action such as query processing or the inputting of additional information from the user. In addition, and often in combination with the icon-based menu, AOL also uses more traditional text-based menus.

One problem encountered with systems like AOL is that menus are typically of unpredictable length as they may change with added content and very often they are quite long. This may prove a liability if the communications medium between client and host is bandwidth limited. A noticeable delay occurs should the entire menu be sent from the host to the client. AOL works around this limitation by only transmitting only a portion of a long menu at a time. Thus, a long menu may be broken into several shorter chunks. Additional chunks

are sent only when the user attempts to navigate past the last item received. AOL also works around the platform-specific issues by arranging the storage of frequently used platform-specific icons and other such information with its client-local interface on the client. One way of accomplishing this is the use of coded information in the stream of host to client which specifies an icon to look up in the client's data base. The client software determines it does not have the item, it asks the host to send it, at which time it is added to the client data base for future use and displayed accordingly.

This system also has several limitations. First, a user must often endure the delay should they wish to access a menu item at the end of a long menu. They must wait patiently as each chunk is downloaded in turn. They receive no direct indication as to how many more items they must transverse to reach the end of a menu, or how many more chunks must be downloaded. Second, should a user navigate to the end of a long menu, the entire menu is now in memory at the client, although the user may only be interested in a single item. On current PC platforms, the amount of memory occupied by a menu may seem insignificant compared to the total content, but in smaller, portable devices, any memory optimization is valuable. Third, the client is responsible for archiving menu embellishments such as icons, which may occupy valuable non-volatile storage space.

It is therefore an object of the present invention to implement a menuing system which has the properties of increased efficiency and having an information content which is independent of the modality of which the content will be presented. It is also desired to add contents specific to modality, without restricting the usefulness of the information stream as a whole. It is also an object to send an information stream (such as a menu) to a client running one of any number of different operating systems with graphical interfaces, or even to a client

who does not have the benefit of such a graphical interface, and to have the stream interpreted correctly, without the necessity of each client's platform-specific software having to interpret information specific to another platform. At the same time, the additional information for use in the system should be available to leverage any advantages inherent in the target system. For instance, a menu to be received by a Macintosh might contain information representing an icon associated with each item, and a screen position at which to display the icon, while this information would be useless to a non-Macintosh platform.

One benefit of such a system is that it can remove a significant amount of processing necessary at the host to deal efficiently with clients of varying platforms. The same menu information stream could be sent to various types of clients without the need to alter the information stream according to the client. A minimal level of functionality is guaranteed at the client, while the host can opt to provide additional functionality in the stream according to its resources (such as storage space or processing speed) or lack of them.

Summary of the Invention

The invention disclosed herein includes a method for employing software to use a virtual menuing system. Specific implementation of those common computer interface components such as menus is disclosed which possesses the properties discussed above and as such represents an improvement in the art.

The present invention is also directed to the problem of developing a digital information commodities exchange in which the data flow is bidirectional rather than unidirectional and in which subscribers can exchange information with each other through the system. A subscriber could just as easily send the same type and quantity of information as he can receive; thus, making

them a publisher. The present invention is also directed to the problem of accommodating different data types within the same modular system, thus allowing for an exchange of a virtually unlimited range of digital commodities. In addition, the present invention provides for the automated conversion and transfer of arbitrary formats beyond the SIM.

The present invention removes the limitations of the electronic bulletin boards described above in the following way. An exchange system is provided, but it is not the ultimate source of any data itself. The exchange system is simply a conduit through which users can perform digital transactions. To further support the development of a data marketplace, the exchange can provide administrative functions such as billing. In addition, transactions are not required to pass through a particular publisher or exchange, therefore, allowing any publisher and subscriber to also communicate directly.

These digital transactions are facilitated by modular expandable units (MEU) operated by publishers and subscribers. A publisher makes a publication available to the exchange via the publisher's own modular expandable unit. Likewise, a subscriber can then subscribe to this publication, using his or her own modular expandable unit, by contacting the exchange to receive the desired publication. Those who wish to use the system as publishers can attach electronic devices to the system which can act as archives specific to the information that the publishers wish to provide, on a case by case basis. However, in no case would subscribers be required to route their transactions through devices belonging to any particular publisher. Any such transaction (publication or subscription) may result in charges to both or neither or either of the parties involved. Because the system is a true bilateral exchange, any supplier can be a subscriber and similarly

any subscriber can be a supplier. The modular expandable units enable the publisher/subscriber to upload and download data in a variety of formats, such as music, text, and computer programs (e.g., personal computer programs, Nintendo programs, etc.) via their inherent expandability. The modular expandable units are also expandable with respect to the form of data transmission, so as to accommodate telephone, satellite, electric power lines, CATV, cellular or fiber optic communications.

10 In a DICE exchange network, if an MEU or general archival device goes off-line, only that device and any subscribers connected to it are affected. The affected subscribers are immediately free to try to obtain the desired data via another source, since their MEUs are still fully functional. This is clearly an improvement over the phone, cable, on-line, or digital packet switching networks described in the prior art.

15 The MEUs enable users to upload or download data in a variety of formats (such as music, text, computer programs, graphics, Nintendo games, etc.) through their expandable architecture. MEUs are electronic devices characterized by an internal data bus, (or multiple buses) connected to a multiplicity of expansion interface slots. A specific protocol is used to move data between a variety of expansion modules which may be connected to the bus via the expansion interface slots. This protocol is always the same no matter the specific circuitry of an expansion module plugged into a slot. Each of these modules, in turn, may be capable of converting data received from the MEU's internal bus to a specific format to be outputted from a plug, connector, or other external interface (also part of the expansion module). Similarly, the expansion module may receive data from an external device via the external interface, convert it to the MEU internal protocol, which then transmits it to another distinct expansion module attached to the MEU's bus(es).

For example, MEU expansion modules can be made available for each of the following data transmission standards: NTSC Video, Optical Digital, Audio, Two-channel Stereo, Audio, Appletalk, Ten Base-T Ethernet, Thin Ethernet, Thick Ethernet, Token Range, Coaxial Cable TV, Analog Cellular, TVMA Cellular, CVMA Cellular, and so on. The idea is to establish an internal standard capable of delivering a throughput sufficient for any digital application, and then to provide translators for any established standard deemed common enough to merit inclusion. The MEU itself speaks none of those standards internally, but merely moves raw data between one standard and another, at the will of its users. In short, the MEU is a device with an architecture that makes no assumptions about what type of data it is handling internally, but allows for additional specialized circuitry to be added as easily as inserting a bank card in an ATM machine, thus, providing an expandability to other and new data transmission formats as they gain acceptance, even though they may not have existed when the MEU design was finished.

The MEU design also anticipates benefits from multiprocessing. All data processing will occur in microprocessors attached to the expansion modules. Each expansion module may in fact house a complete, encapsulated data processing environment, including memory, microprocessors, and other special purpose IC's like digital signal processors. MEUs with one or several expansion modules containing microprocessors could take advantage of multiple data buses and multiple communication lines connected to the expansion modules' external interfaces to break up a large chunk of data into several smaller discrete component data chunks, and transmit them simultaneously over several distinct lines of communications, after which they may be reassembled into a single coherent chunk of data by a similarly equipped MEU which is receiving the data. This method of

simultaneous transmission should be distinguished from the parallel computer interface, which transmits simultaneous bit streams over several distinct strands of wire which are all bound together in a single cable. The difference is that each of those bit streams are governed by the same protocol and, if one wire breaks, any transmission over this interface is impossible. The method to be employed by MEUs splits a data stream over multiple channels, each having its own protocol, possibly distinct physical transport, and which may have distinct protocols. If any one of the multiple channels fails, the MEU can continue, simply by eliminating that channel from consideration.

15 BRIEF DESCRIPTION OF THE DRAWINGS

FIG 1 shows the layout of a small data exchange network in accordance with an embodiment of the present invention, as well as each consumer's intended use.

20 FIG 2 shows the implementation of a data exchange system with three hubs. Several networks are attached to each hub.

FIG 3 shows a typical publisher/subscriber connection in an embodiment of the present invention.

25 FIG 4 shows a modular expandable unit, including its base system, communications converters, and expansion modules according to an embodiment of the present invention.

DETAILED DESCRIPTION

30 The method and apparatus of the present invention will be described using an example of a digital information commodities exchange. However, the present invention is not limited to the exchange of the specific digital information described below.

35 In a digital information commodities exchange operating according to the present invention, the exchange commodity comprises digital information packets.

The information, which can represent a variety of different kinds of data, is encoded in a standard format by an expandable modular unit operated by the publisher/subscriber.

5 A commodities exchange includes a system capable of performing at least four functions: receiving/storing notification of the availability of a particular digital information packet, receiving/storing a digital information packet from a publisher, sending a digital information packet to a subscriber, and maintaining records of a subscriber and/or publisher transaction.

10 A publisher transmits a notification of the availability of a digital information packet to the exchange. The publisher may also notify subscribers directly of the availability of such information in a variety of ways. The publisher can, for example, advertise within the exchange itself or in any other medium such as print (e.g. newspapers). A subscriber can then request transmission of such a packet from the publisher. This publish/subscribe transaction could occur in real time, e.g., the subscriber could achieve access to a live concert, or it could be separated in time, e.g., a subscriber could access a video game that had been published weeks or months earlier. In either case, the publisher transmits the digital information packet over the selected transmission medium to the exchange. To perform the publication transmission, the publisher is connected to the exchange system using a modular expandable unit (MEU) and over the transmission medium of his or her choice. Likewise, the subscriber is connected to the exchange using a modular expandable unit and the medium of his or her choice. However, one MEU can send information directly to another MEU without being connected to the exchange over dedicated lines.

25 Furthermore, these lines do not have to be packet switched.

30

35

Upon receipt of a digital information packet from the publisher, the exchange system can send the packet to the requesting subscriber. The subscriber requests a particular packet using a simple menu-driven process jointly administered by the subscriber's modular expandable unit and the exchange system. To receive the transmission, the subscriber is also connected to the exchange system through his or her own modular expandable unit.

The exchange system includes a network of computers (that may be geographically dispersed) and the communications devices to send and receive various data over various media.

Fig. 1 exhibits a proposed embodiment where the digital information commodities exchange is connected to a number of publishers and subscribers. For the sake of illustration only five users are shown. Element 1 is a commodities exchange system which has the ability to handle many simultaneous publication/subscription sessions. Element 11 is a modular expandable unit of a publisher of digital information packets. In this instance the packets produced by publisher's unit 11 relate to audio data such as music. Element 12 is a modular expandable unit of a home subscriber who can receive data in a variety of forms, including text, audio, video or computer program data. Element 13 is the modular expandable unit of a user who intends to both subscribe and publish digital information packets, in particular audio information. Element 14 is the modular expandable unit of a subscriber who intends to receive music to dub onto his or her own home video tapes. Finally, element 15 is the modular expandable unit of a publisher of digital information packets for hand-held computer games. Initially the publisher 11, using his or her own modular expandable unit, contacts the exchange to make a publication request and to register the publication parameters: artist, title, pricing,

marketing plan, etc. This is accomplished via point selections from menus on the modular expandable unit which is interacting with the exchange. At this point the publisher may wait for a request from a subscriber. 5 Alternatively, depending on the storage capabilities of the exchange, the publisher may wish to store his or her publication on the exchange so that it would be immediately available to subscribers. In this situation a publication-recording session must occur. The 10 publisher 11 might have recorded the audio publication on digital audio tape and would then play and transmit it to the exchange via his or her modular expandable unit and the transmission medium of his or her choice. Alternatively, the publisher may elect to transmit live 15 via an analog-to-digital conversion system to the exchange. In either case the session would be played to completion and stored on the exchange at an appropriate address whereupon the publisher would indicate termination by a signal from the modular exchange unit 20 and the exchange confirming the same.

The subscriber of element 14, after learning of the newly available digital information packet, in this example music, would then use his or her modular expandable unit to make a subscription request to the 25 exchange, using the transmission medium he or she prefers. Again, by moving through a series of menus that refine his or her choices, the subscriber chooses the desired music item. The first menu might list music as one category of available packets, the second menu might 30 list styles of music, the third might list particular artists, the fourth might list an artist's albums and the fifth menu might be a list of the songs on a particular album. A particular song, group of songs or an entire album may be subscribed to as a single digital 35 information packet.

After the subscriber has selected the particular digital information packet which he or she would like to

receive, the exchange 1 receives the request, notifies the publisher's computer (or modular expandable unit) that the digital information packet is to be transferred, prepares the selection for transmission, confirms that the subscriber's modular expandable unit is ready, and proceeds to transmit the selected digital information packet. The quality of this publication will depend on the quality of the publisher's recording equipment and likewise the quality of the subscription depends on the subscriber's equipment.

FIG 2 exhibits a similar system as FIG 1, but on a considerably larger scale. In this figure, several different exchanges 1 are illustrated, each with an arbitrary number of modular expandable units 13 attached to it. This figure also illustrates that a single exchange 1 can be connected to other exchanges 1, as well as to other MEUs. In this way the network can spread in a horizontal sense so as not to overburden a single exchange with too many units 13. Also, the network can spread in a vertical sense by nesting one exchange within another. Note that this configuration allows the network to incorporate and complement existing systems, such as Comuserve®, etc.

As is evident in FIG 2, a distinguishing feature of the exchange of the present invention and other exchanges or networks lies in the administrative functions the exchange performs. Each exchange has a user directory 41 and a digital information packet directory 42. Digital information packet directory 42 does not contain the actual packets themselves, but rather is a list of where the packets are located on the exchange. The user directory 41 is a list of which users are located at which addresses on the exchange. In contrast, networks not of the present invention, denoted 50 in FIG 2, need only have a user directory 41. This is because their "digital information packets" are contained within their central singular computer rather than distributed amongst

many different digital commodities 'brokers' 13. Finally, it is important to note that user 13 is not limited to those digital information packets located in the directory 42 of his or her own particular exchange 1. 5 This is because a particular exchange 1 may also search other exchanges throughout the system for a particular requested digital information packet. This packet could then be sent to the user in a manner completely analogous to the transfer of a packet from a publisher to a 10 subscriber.

Although the best quality recording is stored on a master tape originally made at the studio, exceptionally high quality reproductions can be achieved after a conversion to a compact disk standard format (CD). Thus, 15 it is likely that the publisher will upload the reproduction from a compact disk. While a typical CD player would convert the data from a digital format to an analog format before sending it to the amplifier, in this case the signal could be removed from the CD player at 31 20 in a digital format and could be directed to the modular expandable unit's expansion module in that same format. The expansion module 32 provides the necessary connectors to interface the CD player with the modular expandable unit through the control unit 33. The modular expandable 25 unit can then provide any necessary data compression. The signal can then be sent over a telephone line 5 via a modem, with the modem also providing the necessary conversion to an analog format. If, in the alternative, a fiberoptic cable were employed, the data could remain 30 in digital format.

The maximum amount of information to be sent can be calculated as follows. Using a band width of 3300 Hz and a signal-to-noise ratio of 20 dB, it is estimated that a telephone channel can handle about 22,000 bits of data 35 per second. Standard modems today have bit rates of up to 19,200 bits per second. Use of an ISDN standard and digital switches would allow a rate of up to 64,000 bits

per second to be achieved. A compact disk player, handling the audio frequency range of up to 20 kHz, and taking into account the Nyquist frequency of the disk player and the need for two channels for stereo sound, would require about 80,000 bytes per second. The large data rate mismatch would require, on the publisher's side, a buffer 32, as depicted in FIG 3, to store data prior to the data being sent over the telephone line. The size of the buffer would depend on the length of the digital information packet to be sent. Once the data is buffered and sent over the telephone line, a buffer 23 on the subscriber's side would restore the data to its original rate. The data could then be stored in a variety of forms. Each buffer 23 forms part of its modular expandable unit. The expansion module 24 could be equipped with both digital and analog outputs. The digital output emerges directly from the modem. The analog output is simply the digital output after processing by a digital-to-analog converter. In the present example, the signal can then be sent into either a digital or analog input of a digital audio tape player.

In the course of buffering the data, compression techniques can be used to speed the transfer. Other techniques, such as storing the data on RAM chips, can be used to minimize the time necessary to maintain the telephone connection. Additionally, if a fiberoptic link is used to transfer the data, the wide band afforded by the fiberoptic would allow the packet to be sent even more expeditiously.

Publishers and subscribers can be connected to the exchange system over any one of a variety of transmission media 5. For example, they may choose to be connected to the exchange system over private circuits, television lines, the public switched telephone network, cellular communications, electric power lines, or even satellite communications. Depending on the type and amount of data

to be sent, some of the digital information packets could be sent over one type of medium and simultaneously another part could be sent over a different type of medium. For example, if a movie were to be transmitted to a subscriber, the audio portion of the movie contains considerably less information than the video. Thus, the telephone line, with its limited band width, is sufficient to transmit the audio portion of the movie. A higher band width transmission medium such as a fiberoptic, a cable TV line, or a power line could be used to transmit the video, thus allowing a more rapid transfer of a digital information packet. The exchange provides this versatility by being equipped with a large variety of transmitters/receivers interfaced to many types of transmission media.

The exchange system is capable of performing administrative functions with respect to the publication/subscription transactions. The exchange system interacts with publishers and subscribers via menu-driven software so that the users can easily perform the desired transactions. The exchange system can also maintain profiles of subscribers and their usage in such a way that subscribers may be kept informed of newly available digital information packets that may be of particular interest. Publishers may be kept informed of who is subscribing to their publications and any other relevant market information. To support the exchange system, transaction fees may be charged to either the publisher, the subscriber, or both. Furthermore, the exchange system can track the publications and subscriptions so that either the exchange system or the publisher can bill the subscriber for the price of the digital information packets. The exchange can provide many options regarding the commercial aspects of the digital information commodity exchange. For instance, various price mechanisms can be supported. In this way the subscriber can be charged less per packet for

ordering a higher quantity of data, or alternatively can be charged less for ordering a data reproduction of lesser quality. For example, a video for use on standard televisions would cost less than one for use on high-
5 definition televisions. Some publishers would pay to have their publications subscribed to. An example might be a car company who would issue an exchange credit for the first 1000 subscribers who receive their video of a test drive of the company's new luxury car. Similarly,
10 receiving a live lecture from a Nobel Laureate might cost more than receiving the same lecture pre-recorded.

FIG 4 schematically illustrates a modular expandable unit. A modular expandable unit can provide the interface to the exchange system for either a publisher
15 or a subscriber. A modular expandable unit includes a central processing unit and various expansion modules 24. The central processing unit includes an input, an output, a serial line for connecting the input to the output, software running on a microprocessor which may be used to
20 select which digital information is desired, and a system for entering commands. The software system can be in the form of microcode or can utilize other known techniques such as EPROM. Obviously contrary to some popular usage, the term central processing unit as used here encompasses
25 more than just a microprocessor. A base system of the modular expandable unit is used to send requests to the exchange and may include a small video screen 22, an apparatus for inputting commands 26 (e.g., a keyboard or a pointing device), and software for user interaction.
30 In addition, the MEU is capable of accepting input and output from several known techniques such as a keyboard, a CRT, a modem, etc. The software serves to configure the hardware and to control the conversion of data with the appropriate add-on communication module. The unit is
35 also capable of sending digital information packets to the exchange system, receiving digital information packets from the exchange system, reformatting data

received from the exchange system for replaying on a specific device, and playing or recording digital information packets thus received.

5 The modular expandable unit is capable of sending and receiving digital information packets to and from the exchange system over a selected transmission medium 5. If the transmission along a particular data link fails, it does not preclude the parties in that link from immediately re-establishing the connection in another link. 10 The unit may also have a variety of expansion modules 24 available, some of which serve to format a particular data type and others which serve to adapt the modular expandable unit with a particular transmission medium. For example, if a publisher wants to send a 15 digital information packet from a digital audio tape (DAT) over an ISDN connection to the exchange, the MEU would have an expansion module 24 allowing the MEU to interface to an appropriate DAT device and would have an expansion module to interface to the ISDN circuit. The 20 data coming from the DAT device would be received by the expansion module, reformatted and buffered, as necessary, by the unit and then the modular expandable unit would send the data to the exchange system 1 over the selected transmission medium 5. Examples of appropriate expansion 25 modules 24 for audio data are those that accommodate devices using digital audio tapes, digital compact cassettes, analog speakers, analog cassettes, 9-track tapes, and telephones, however, other expansion modules might be used. Standard interfaces also exist for other 30 data types: NTSC video, serial/parallel PC, Group III fax, etc.

In the example noted above, the subscriber at element 13 received a digital information packet from a publisher at 11. This same subscriber may wish to send 35 a digital information packet to the publisher for review, and perhaps future publication. Thus, the consumer at element 13 will then in turn be acting as a publisher.

If the consumer at element 13 is a relatively small publisher, the manufacturing technology of producing a compact disk may be unavailable. He or she can still, however, record a digital information packet on an analog or digital audio tape. That digital information could then be sent to the exchange system using the same technique described before. In this case, rather than a menu-driven method of locating the information, the consumer may use a known address to send the information to the recipient. The recipient of the digital information packet at element 11 may store the data in RAM or perhaps in a tape format. The consumer at element 13 does not require a DAT player; a regular analog tape player suffices. In that case, however, the modular expandable unit to which it would be connected would need to be equipped with an analog-to-digital converter which could convert the data on the tape to a form usable by the modem. As stated before, this is because the bandwidth needed for most music is about 20 kHz while the bandwidth usable by a telephone is on the order of 4 kHz.

In addition to audio data, the modular expandable unit could also interface with video data devices and computer data devices through appropriate expansion modules 24. Examples of appropriate expansion modules for video data are those that would interface with devices using VHS tapes, Beta tapes, VHS-C tapes, and 8 mm tapes. Examples of appropriate expansion modules 24 for specialized video data are those that accommodate high-resolution video/graphics screens. Examples of appropriate expansion modules 24 for computer data are those that accommodate devices using parallel ports, serial ports, printers, magnetic disks, magnetic diskettes, magnetic tape, flash RAM, EPROM, and ramdisks. Of course, for all of the above varieties of data, if the data type is initially analog, it must be converted to one of the standard digital formats prior to being published on the exchange. This analog-to-digital

converter can be a separate module attached to the modular expandable unit and may be bidirectional.

5 The modular expandable unit 14 is capable of receiving digital information packets from the exchange system 1 over the selected transmission medium 5. After the subscriber requests a particular digital information packet, the requested digital information packet is transferred to the modular expandable unit via the selected transmission medium. The received requested data could be played in real time, could be stored in temporary memory for a later one-time-only play, or could be directed through an appropriate expansion module 24 to a particular recording device, such as those named above, where it may be recorded and thereafter repeatedly played.

10 The modular expandable unit would further be capable of recording and playing back digital information packets received from the exchange system 1. Once the digital information packet has been received by the modular expandable unit 14, it is directed to an expansion module 24 which acts as an interface for a particular device which is related to the type of data received. For example, if the requested digital information packet is a computer program, the MEU 14, through the appropriate expansion module 24, could store the program onto a hard disk or diskette. In this same example, if a computer program required a particular operating system with which to run, the operating system could also be downloaded as a separate digital information packet. In addition, if the publisher desires, a copy-inhibit feature could be included by the publisher and would be transmitted along with a particular digital information packet to prevent software piracy.

25 The received data can then be sent from the MEU 14 to any of the devices that can use digital data and are connected to the expansion modules 24 as described above.

In the example shown in FIG. 1, a subscriber at element 14 may wish to receive a digital information packet from publisher 11. This digital information packet could, for example, be music which is to be dubbed onto a home videocassette. In this case, the transfer would be similar to that described above. The music would be replayed at element 11, buffered, sent over the phone line 5 to the exchange system 1, and then sent to the modular expandable unit 14 to be re-buffered at 21 and output as a digital information packet in the same form as it was played by the publisher. This digital information can then either be sent, in this example, to the digital audio input of a videocassette recorder, or can be first sent to a digital-to-analog converter, and then sent to the analog audio input of a videocassette recorder.

In the example shown by FIG. 1, the publisher at 15 could be a software publisher who sells software products over the DICE to subscribers. A subscriber at element 12 could use the same menu-driven process as described above to request a particular digital information packet, in this case a software product. The program might then be uploaded from the publisher to the exchange system 1 and sometime later downloaded to a requesting subscriber. This type of transfer would be considerably quicker and simpler than the above-mentioned transfer of video and audio digital information packets, because there is usually much less information contained in this type of digital information packet.

In another embodiment, two private individuals may use DICE to exchange a digital audio recording. Letters "A," "B" will denote two different subscribers at two remote locations. Assume both individuals have one MEU containing the following: a primary interface expansion module, an LCD display pad, a keypad, two POTS expansion modules, one RAM expansion module, one digital audio expansion module with a digital audio input and output,

and one flash-file expansion module. Individual A has a DAT system and two POTS telephone lines. Individual B has a home entertainment center, including a stereo and two POTS telephone lines. Subscriber A would like
5 subscriber B to hear an excerpt of his latest musical composition. Thus, A contacts B via voice phone. Subscriber A asks subscriber B if he is ready to receive and B responds affirmatively. Then, both subscribers hang up the line. At this time, subscribers A and B
10 connect their two POTS lines to each of their respective MEUs. Individual A has stored his compressed digital recording in RAM on his MEU and (selecting from a series of menus displayed in the MEU LCD) programs his MEU to transfer the recording from his MEU to the phone number
15 of B. Subscriber A sends information informing the MEU of subscriber B of what resources (e.g., phone numbers) are available. It then asks the MEU of subscriber B for similar information.

It is now the job of subscriber A to determine that
20 it can transfer data over a dedicated line to MEU B. In doing so, once this acknowledgment is made, subscriber A dials up subscriber B along one of the dedicated lines. Once a connection has been made, subscriber A allocates a percentage of data to send over each line (50% is the
25 case shown if both lines have identical characteristics). Subscriber A partitions the data, encrypts it, and queues each of the chunks to the POTS expansion modules. Subscriber A informs the MEU of subscriber B of the intended transfer over one of the dedicated lines.
30 Subscriber A further signals the POTS expansion modules to commence a simultaneous transfer over the dedicated lines. Subscriber B encrypts the data and re-integrates it from the two POTS modules into RAM. After this, subscriber B may then hang up the dedicated line as well
35 as can subscriber A. Subscriber B may see a displayed message that the transfer is done and complete and may unplug from both POTS lines. Subscriber B further may

pull the stereo line out of his MEU and the selection may be used to play the RAM resident data through his stereo output. The transfer is completed and subscriber B is able to listen to an excerpt of musical composition from subscriber A.

5 A virtual menuing means or system is also provided for a remote interface to information systems. Such a system has three components. First, the host device contains the complete menu. The client has a device
10 linked to the host by an arbitrary telecommunications link, which receives discrete portions of the menu from the host, presents this to a user, and relays selection codes from the user to the host in the context of the menu.

15 The client implements a "menu window" over the larger host-based menu, which contains only a subset of the menu items available at the host. This window at the client can be moved dynamically over the full range of the host-based menu, providing access to all menu items.
20 Traversal of the host-based menu need not be in contiguous increments, however. To solve the problem of making an arbitrarily long list of menu items accessible to a client, menu items are presented in a manner analogous to a voice mail type of menu, with a touchtone
25 keypad. This specific scenario might be handled at the client. Clients which use the virtual menuing system described here would maintain the following information:

(1) a "range" of "floating" items R representing the traditional scrolling area of a menu, and
30 (2) a range of "hot key" items H that remain at a fixed location regardless of any scrolling of the floating items.

The number of menu items (M) in a host may be equal to nine (corresponding to touch tone digits 1-9). The
35 number of "hot key" (H) items visible in the client menu may be equal to three (corresponding to the touch tone keys *, 0, and #), which are typically special function

keys in a voice menu. The value of M is arbitrary. In general practice, M is greater than or equal to the floating range number of items (R), which are the number visible at one time in the client's menu. If not, no
5 scrolling would be necessary at the client, and only M less than R would be valid menu choices, with the balance remaining as unused and displayed as blank items. The number of hot key items actually used can be any number less than or equal to H.

10 The host maintains a menu as a single contiguous list of items. Each item has at least an ASCII string identifier and an index number unique to the item. Typically, such numbers would start at "1" and increase for each item but any such arrangement is possible.

15 The total number of items displayed at the client equals the number of floating items plus the number of hot key items. The sum is the number of items actually displayed on the interface of the client device. The floating and hot key items are maintained in contiguous
20 arrays. Clients communicate their configuration with regards to the number of each type of item to the host.

For a given client, the host maintains a menu base indicator, representing which item in its menu list the client has displayed as the first item in the floating
25 area. It also knows the floating range of the client. So the current main chunk seen by the client is the range of items starting from the base. Aside from the number of hot keys transmitted once for the menu, the host sends chunks of range R items. The configuration also includes
30 information regarding the scrolling increment of the client wishes to use.

The hot keys could perform any number of functions. In the case of a 100-item menu, with a floating range of ten items, if the user was at the beginning of the menu,
35 and used a hot key function to zoom to the end, the host could simply set its base to item 91, directly from item 1, and send items 91 to 100, thus saving the transmission

of the intervening 80 items. In a typical scenario, a 100 item menu might be rare, and even considered a poor design. As the market for interactive and on line content evolves, however, large menus representing catalogs of content will be quite commonplace.

In general, the system implements a two-way data stream between the host and client. The host transmits menu chunks, as well as updates to individual or small numbers of menu items, to the client, while the client sends selection codes to the host. The selection codes include tokens representing the various hot keys, as well as navigation codes such as Up, Down, In, Out, (for hierarchical menu navigation), Select, and Zoom.

The following codes are examples of those that may be sent from the client to the host in response to user actions at the client.

SelectUp

If the current menu item at the host is greater than one, it is decremented by one. If the resulting current menu item is less than the base, the base is decremented by the client's scroll increment, and the menu chunk from the base item of R items is transmitted to the client. The client displays the new menu chunk, effecting a scroll up.

SelectDown

Similar to SelectUp, except the current item is incremented if it is less than M. If the current item exceeds the item computed by adding the range R to the base, then the base is incremented by the client's scroll increment and the menu chunk is transmitted from the base item of R items to the client. The client displays the new menu chunk, effecting a scroll down.

SelectIn

If the current menu items is itself a menu, the host is initialized with the new menu information, and a menu definition is transmitted containing summary information on the new menu to the client, which clears its display. The host base is set to item one. If there are items in this menu, then the menu chunk is sent starting from the base. The client displays the new menu.

10 **SelectOut**

If the client has navigated inside a sub-menu, that menu is unloaded recovering the previous menu, initializing the host to base one, and a new menu definition is transmitted. Further, the first menu chunk is sent to the client. The client displays the menu which contained the menu it previously displayed.

SelectCurrent

This signals the host to perform some operation related to the menu item currently highlighted in the client menu. This is the current menu item at the host. The action triggered is determined by the host.

SelectZoom (i: 1 > = i > = R)

This sets the current menu item at the host to correspond to the client menu item within the client's currently displayed floating range, which is indicated by the value of i. The current item is computed by adding i to the base and subtracting 1.

30

Select HotKey

Any number of predefined functions could be tied to hotkey codes. There are three types of menu transmissions from the host to the client. Each current menu item is highlighted in the client display.

Menu Definition

This includes information on how many columns to display in the menu, and what the labels of such columns are (if there are multiple items per row). One row is still
5 considered one menu item. Each row may have multiple segments, with each segment applying to a column in the definition. It might also include information on hotkey items.

10 Menu Chunk

This represents a complete range of menu items. If a client was configured with a floating range of nine items, then each menu chunk would contain the data for the nine rows of the menu, including all row segments for
15 each item.

Menu Update

Data included in this message can be used to alter the display of individual menu items without redrawing a
20 complete menu range, or to change the information on hotkey functions. It would be used to immediately add a check mark to an item that was selected using SelectCurrent. Although the client might do this himself, if he waits for the host to send a Menu Update,
25 the client reflects the actual state of the host.

The present invention is well-adapted to the recent development of multimedia microprocessors. For example, AT&T's 32-bit Hobbit microprocessor has a built-in
30 communications ability, as well as a multitude of connectivity products being designed for it. These include applications allowing users to interact with multimedia in real-time over telephone lines. Such a microprocessor would well serve the needs of a digital
35 information commodities exchange and in particular the MEU. Depending on the connectivity of the products that are designed for the Hobbit microprocessor and its built-

in communications facilities, the need for elaborate buffering of data may be less necessary than envisioned above. For example, the Hobbit microprocessor's communications abilities may be used to simplify much of the transmissions requirements.

Menu-driven software on the MEU would allow users to request digital information packets. This software interacts with software running on the exchange. Communications software on the exchange and on the MEU coordinates the transmission of digital information packets between them.

The menu-driven software could first request a publisher/subscriber's identification number and password for verification. The software would then inquire whether the publisher/subscriber chooses to publish a digital information packet, subscribe to a digital information packet, or gather information about a digital information packet.

If the publisher/subscriber chooses to subscribe to a particular digital information packet, he or she would conduct a search to find that digital information packet by maneuvering through one or more menus and thereupon requests it. If a publisher/subscriber wishes to post a publication on the exchange, he/she also "logs in" but then inputs the particulars of his/her publication. The menu-driven software can be similar to that used, for example, by the Prodigy® Network where the user first views a menu with a choice of different types of news stories, such as business news, politics, sports, etc. Once the subscriber chooses a particular type of story, the subscriber is then presented with another menu with a choice of other stories, all within that same type of news. After choosing a story from this menu the user is then actually looking at the text of a news story. Alternatively, a program similar to Apple® Computer's Applesearch® program could be employed to facilitate key word searches of data. Applesearch® is also used to rank

the retrieved documents by relevance. In the present system, the user would have a menu with choices of different types of data to request. These menus would ask the user if the information requested is textual, 5 visual, aural, etc. or a combination of these. The categories would further divide into news, music, movies, educational, and other subdivisions. After several iterations of choices, the user would find the appropriate digital information packet, and request it. 10 The user further could specify to what device the digital information packet is to be sent. The exchange system, after verifying the functionality of all the appropriate ports, would arrange the transfer, from the digital information commodities exchange, of the requested 15 digital information packet to the subscriber's MEU where it would be directed to the expansion module associated with the specified attached device, and optionally would bill the subscriber accordingly.

If the publication is meant for real-time access and 20 the publisher is connected to the exchange at all times, then the information could be routed from a publisher to a subscriber at any time the subscriber chooses. If this publisher is only intermittently connected to the exchange system, then the subscriber would wait until the 25 publisher is on-line again before the data could be requested and transferred from the publisher through the exchange system 1 to the subscriber. Alternatively, if the publisher has stored his or her publication on the exchange, the digital information packet would be 30 available whenever a subscriber wishes to subscribe to it. In any case, after the subscriber specifies the digital information packet to be sent, notification of the time of sending, whether immediate or in the future, would be given to the subscriber.

35 If the publisher/subscriber chooses to publish a particular digital information packet, occasionally in response to a subscriber request, he or she could replay

the digital information packet and also describe to the exchange system 1 what the electronic standards are for replaying the data. The publisher also specifies price and distribution information. The publisher then
5 specifies to which subscriber the digital information packet is to be sent. The exchange system again verifies the functionality of the selected ports. The digital information packet is then sent through the exchange system to the subscriber. Billing information is again
10 recorded.

To verify the integrity of a received digital information packet, a data flag could be put on to the end of the digital information packet. The flag would thus notify the exchange that the entire packet was
15 received. The publisher/subscriber would then choose to publish another packet, request a packet, or disconnect the call.

The invention describes an exchange where the traded commodities are digital information packets. The digital
20 information packets consist of a wide variety of different types of data. A relatively large number of publishers can make available a number of different data types to an equally wide variety of subscribers. The subscribers, via their modular expandable units with
25 menu-driven software, can specify which digital information packets they would like to receive, in which format they would like to receive the data, and whichever transmission media they may prefer. Once the exchange is made aware of the subscriber's request, it sends the
30 requested digital information packet to the subscriber. The exchange system records information about all the publication/subscription transactions and bills the publishers and subscribers accordingly.

WHAT IS CLAIMED IS:

1. A system for the exchange of digital information packets, comprising:

5 an exchange including a plurality of connectors for interfacing said exchange to a plurality of transmission media;

10 a plurality of modular expandable units, each of said plurality of modular expandable units having at least one input source terminal, at least one output terminal, and a central processing unit between said at least one input and said at least one output terminals; and

at least one transmission medium;

15 wherein said plurality of modular expandable units are connected to said exchange through said transmission medium to allow the first transfer of a user-selected amount and type of digital information from a first one of said plurality of modular expandable units to a second one of said plurality of modular expandable units,

20 and wherein said plurality of modular expandable units are connected to said exchange through said transmission medium to allow the second transfer of a user-selected amount and type of digital information from the second one of said plurality of modular expandable units to at least a third one of said plurality of modular expandable units,

25 such that said first one of said plurality of modular expandable units is capable of transferring data to said second one of said plurality of modular expandable units over two transmission media simultaneously.

35 2. The system for the exchange of digital information packets of claim 1, wherein said input source terminal includes a module selected from plurality of expansion modules, each of which can accommodate one variety of signal input.

3. The system for the exchange of digital information packets of claim 1, wherein said output terminal include a module selected from a plurality of available expansion modules, each of which can
5 accommodate one variety of signal output.

4. The system for the exchange of digital information packets of claim 1, wherein said central processing unit includes:
10 software running on a microprocessor suitable for selecting digital information;
a system for entering commands;
an input;
an output; and
15 a serial line;
such that said serial line connects said at least one input to said at least one output.

5. The system for the exchange of digital information packets of claim 1, wherein said central processing unit includes:
20 software suitable for selecting digital information;
a system for entering commands; and
a parallel line;
25 such that said parallel line connects said at least one input to said at least one output.

6. The system for the exchange of digital information packets of claim 1, further comprising:
30 an information buffer connected to said expandable module;
such that said information buffer allows for the asynchronous communication of digital information between said exchange and one of said two modular expandable
35 units over said transmission medium.

7. The system for the exchange of digital information packets of claim 1, further comprising:

an information buffer connected to said exchange;
such that said information buffer allows for the
5 asynchronous communication between said exchange and one
of said two modular expandable units over said
transmission medium of digital information.

8. A method for the exchange of digital information
10 packets, comprising:

(a) creating a digital information packet wherein
the packet includes:

(i) a series string of data representing
desired information;

15 (ii) a publisher address, corresponding to the
location of a publisher creating said digital information
packet;

(iii) a digital information packet directory
entry, corresponding to a publishable address which is be
20 used to locate and order said particular digital
information packet;

(b) transmitting said digital information packet
directory entry and said publisher address from a modular
expandable unit to an exchange over a transmission
25 medium;

(c) publishing said digital information packet
directory entry and said publisher address over the
exchange by filing and cataloguing, according to subject
matter and type of medium supported, said digital
30 information packet directory entry and said publisher
address;

(d) compiling a list of said digital information
packet directory entries and corresponding said publisher
addresses;

35 (e) making available said list to subscribers with
modular expandable units;

(f) locating a particular desired digital information packet by choosing one of said digital information packet directory entries from said compiled list over said exchange by using another modular expandable unit;

(g) subscribing to said digital information packet over said exchange by using one of said modular expandable units and providing information to said exchange, including:

(i) subscriber address where said digital information packet is to be sent;

(ii) the publisher address where said digital information packet is to be sent from;

(iii) the digital information packet directory entry where said digital information packet is stored;

(h) transferring said digital information packet from said publisher to said subscriber over said transmissions medium;

(i) concurrent with step (h), buffering said transfer of said digital information packet from said publisher to said subscriber such that said transfer occurs asynchronously.

9. The method of claim 8, wherein said steps of buffering of said transfer of said digital information packet is performed by both said publisher's and said subscriber's modular expandable units.

10. The method of claim 8, wherein said desired information is analog data which is then converted to digital form by an expansion module forming part of the modular expandable unit to provide said series string of data.

11. The method of claim 8 comprising the further step of:

storing said transferred digital information packet in a static semiconductor memory.

5 12. The method of claim 8 comprising the further step of:

storing said transferred digital information packet on a magnetic medium.

10 13. The method of claim 8 comprising the further step of:

playing said transferred digital information packet on a device appropriate to that data type.

15 14. The method of claim 8 comprising the further step of:

billing said subscriber for the transfer and price of said transferred digital information packet.

20 15. The method of claim 8 comprising the further step of:

billing said subscriber by said exchange for the transfer and price of said transferred digital information packet.

25 16. The method of claim 8, wherein said step of creating said digital information packet, occurs at the same time as said step of transferring of said digital information packet,

30 such that said transfer can be effected for real-time transmission of contemporaneously created data.

17. The method of claim 8, wherein data compression techniques are utilized to speed said transfer of said digital information packet.

35

18. The system for the exchange of digital information packets of claim 1, further comprising an

expansion module coupled to said input source terminal, said expansion module accommodating a particular variety of signal input.

5 19. The system for the exchange of digital information packets of claim 1, wherein said exchange may be communicably connected to another exchange.

10 20. A system for the exchange of digital information packets, comprising:

 an exchange including a plurality of connectors for interfacing said exchange to a plurality of transmission media;

15 a plurality of modular expandable units, each of said plurality of modular expandable units having at least one input source terminal, at least one output terminal, and a central processing unit between said at least one input and said at least one output terminals; and

20 at least one transmission medium;

 wherein said plurality of modular expandable units are connected to said exchange through said transmission medium to allow the first transfer of a user-selected amount and type of digital information from a first one of said plurality of modular expandable units to a second one of said plurality of modular expandable units,

25 and wherein said plurality of modular expandable units are connected to said exchange through said transmission medium to allow the second transfer of a user-selected amount and type of digital information from the second one of said plurality of modular expandable units to at least a third one of said plurality of modular expandable units,

30 such that said first one of said plurality of modular expandable units transfers data to said second one of said plurality of modular expandable units over at least two transmission media simultaneously.

21. A system for the exchange of digital information packages comprised of:

an exchange including a plurality of modular expandable units (MEUs), where each of said MEUs includes:

a subsystem of circuitry having a plurality of IC's and memory devices;

a control bus connected to and used in tandem with said subsystem;

wherein said control bus provides regulated coherent access to at least one wide bandwidth high clock speed data bus such that said data is physically and logically separated within each of said MEU devices;

a plurality of expansion module interfaces, each of said interfaces providing a connection between said control bus and said data bus;

wherein said connection is dynamically completed or broken by said subsystem in accordance with requests transmitted over said control bus;

a plurality of connectors for interfacing said MEUs to a plurality of transmission media;

wherein said MEUs are connected to said exchange through said plurality of transmission media to allow the transfer of digital information from any one of said MEUs to any other of said MEUs.

22. The system for the exchange of digital information packets of claim 21 wherein one of said plurality of expansion modules transmits and receives information by said data bus and an external interface.

23. The system for the exchange of digital information pockets of claim 22, wherein said expansion module further comprises:

a microprocessor; and

a memory device;

said microprocessor, said memory device, and said external connection operating in a first condition to convert digital information received from at least one external source connected to said external interface to
5 a format to be transmitted to said expansion module interface;

and operating in a second condition to convert digital information transmitted away from said expansion module interface to a format to be received by at least
10 one external device.

24. The system for the exchange of digital information packets of claim 21 wherein said subsystem is used to control said microprocessor.
15

25. The system for the exchange of digital information packets of claim 21 wherein said transmission media is any assembly capable of transmitting digital information.
20

26. The central processing unit of claim 4 where said software is microcode.

27. The central processing unit of claim 4 wherein said software is stored in EPROM.
25

28. The system of claim 21 wherein at least one of said MEUs is connected directly to at least one other of said MEUs over one transmission medium.
30

29. The system of claim 28 wherein at least one of said MEU's is connected directly to at least one other of said MEU's over at least two transmission media.

30. The system of claim 1, further comprising means for virtual menuing.

41

31. The system of claim 21, further comprising means for virtual menuing.

5

10

15

20

25

30

35

FIG. 1

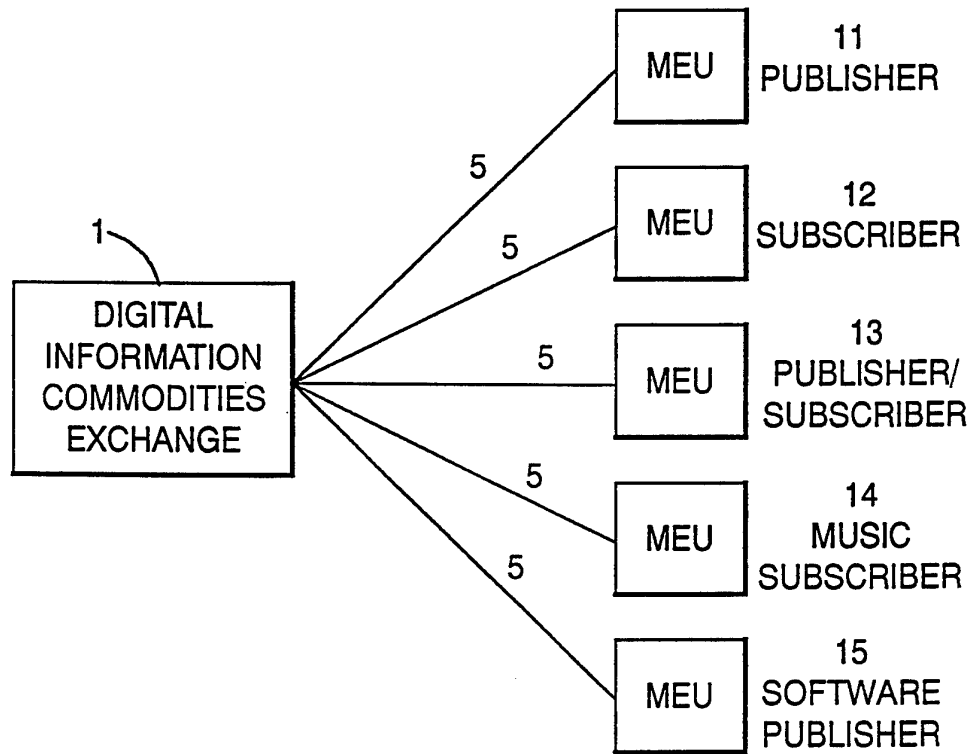

SUBSTITUTE SHEET (RULE 26)

FIG. 2

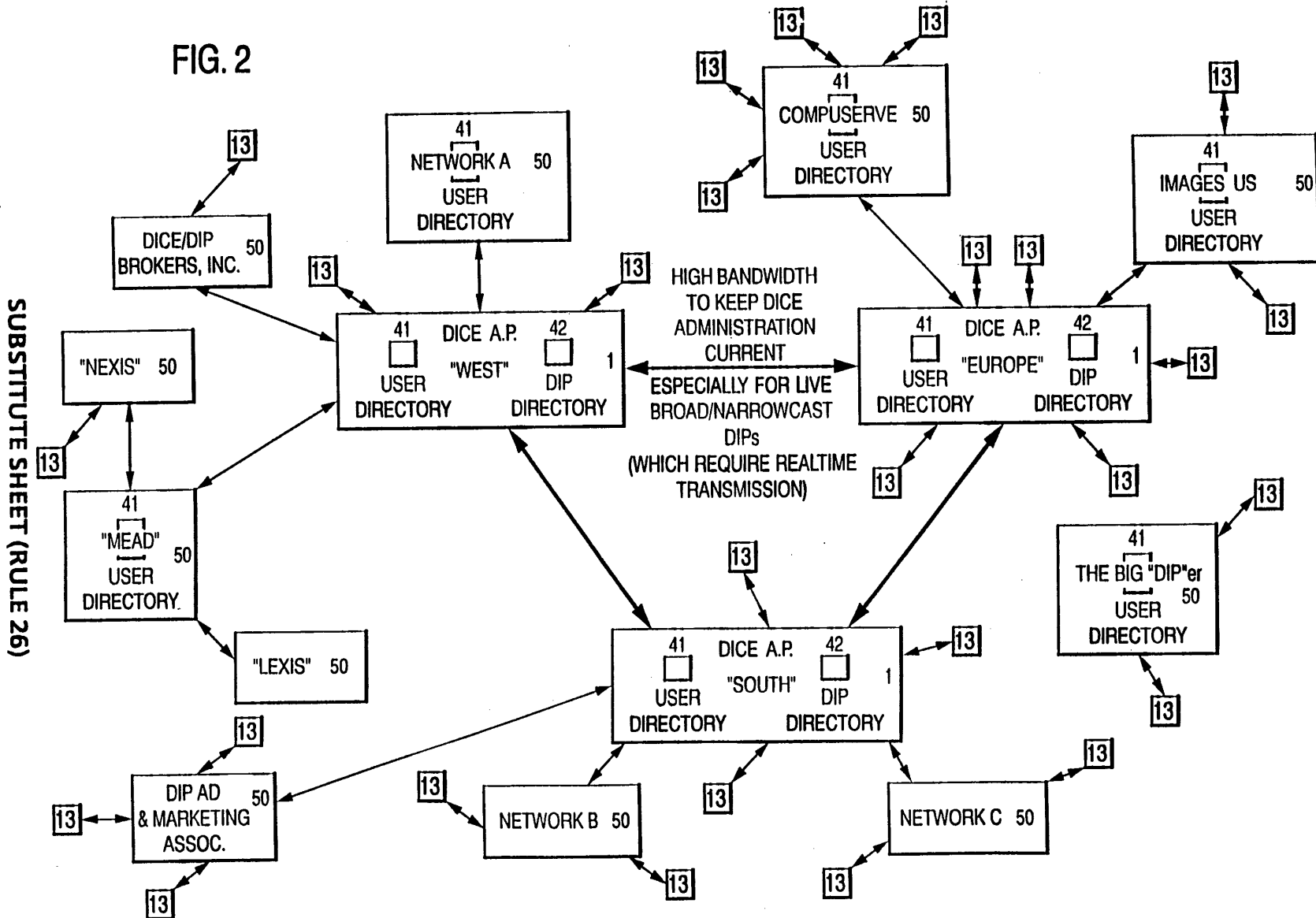

SUBSTITUTE SHEET (RULE 26)

WO 97/01892

2/3

PCT/US95/08159

FIG. 3

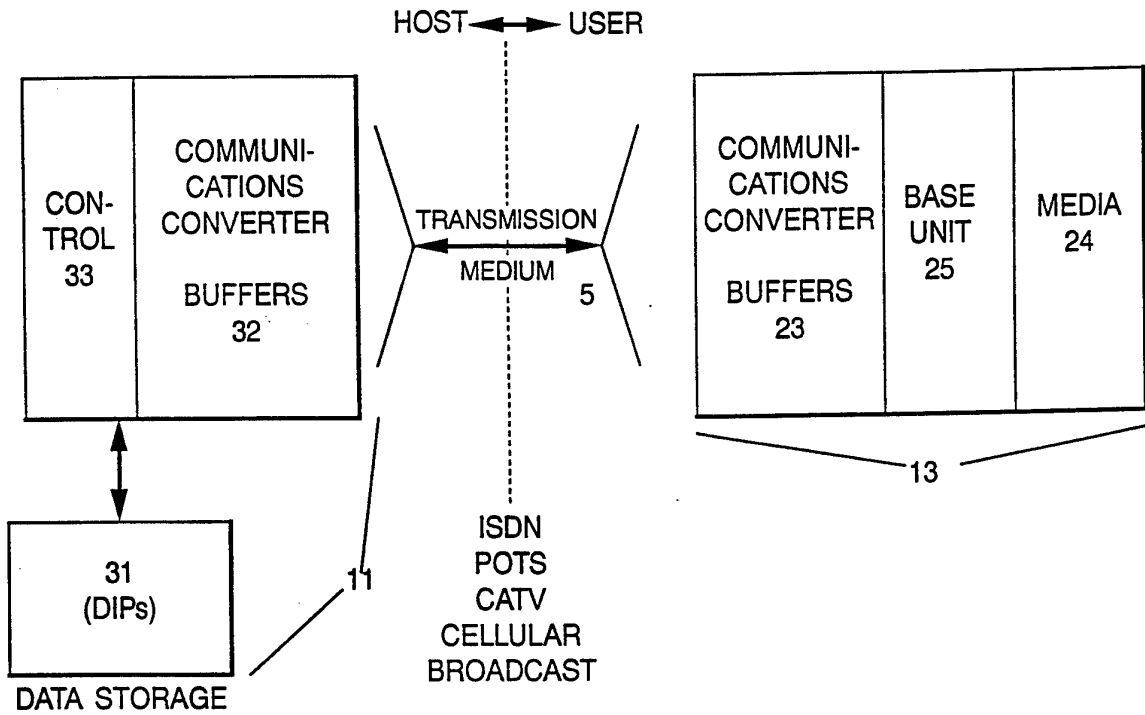
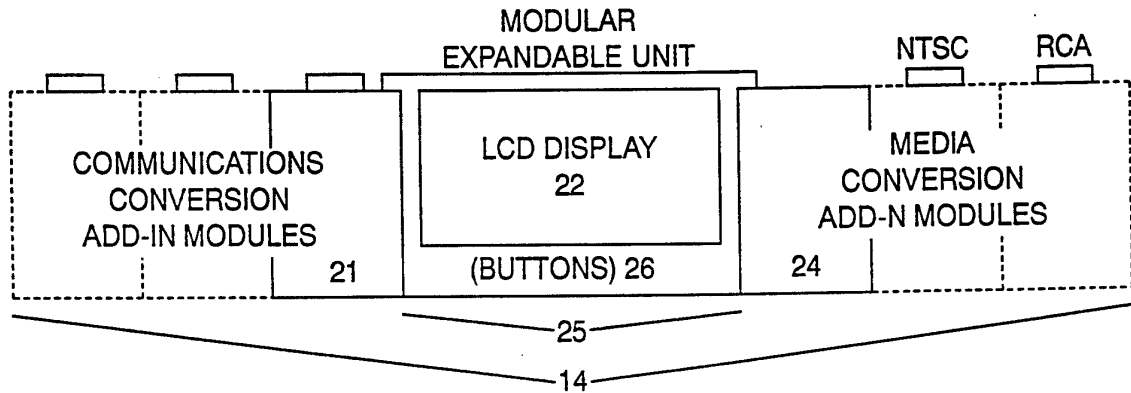

FIG. 4



SUBSTITUTE SHEET (RULE 26)

INTERNATIONAL SEARCH REPORT

International application No.
PCT/US95/08159

A. CLASSIFICATION OF SUBJECT MATTER		
IPC(6) :H04B 13/00; H04J 3/26; H04L 12/40 US CL :370/60, 85.11, 85.11; 375/260 According to International Patent Classification (IPC) or to both national classification and IPC		
B. FIELDS SEARCHED		
Minimum documentation searched (classification system followed by classification symbols) U.S. : 370/32, 53, 54, 58.1, 58.2, 60, 60.1, 61, 62, 85.1, 85.11, 94.1; 375/257, 260, 267; 348/6, 7, 8, 10, 12, 16; 379/110, 219, 220		
Documentation searched other than minimum documentation to the extent that such documents are included in the fields searched		
Electronic data base consulted during the international search (name of data base and, where practicable, search terms used)		
C. DOCUMENTS CONSIDERED TO BE RELEVANT		
Category*	Citation of document, with indication, where appropriate, of the relevant passages	Relevant to claim No.
Y	US, A, 4,491,983, (PINNOW et al) 01 January 1985, col. 3, lines 22-45, col. 4, lines 16-33, col. 4, line 44 to col. 5, line 20.	1-7, 18-20, 26-27 and 30
Y	US, A, 4,958,341 (HEMMADY et al) 18 September 1990, col. 6, lines 4-59 and figure 2.	1-7, 18-20, 26-27 and 30
<input type="checkbox"/> Further documents are listed in the continuation of Box C. <input type="checkbox"/> See patent family annex.		
* Special categories of cited documents:	"T"	later document published after the international filing date or priority date and not in conflict with the application but cited to understand the principle or theory underlying the invention
"A" document defining the general state of the art which is not considered to be part of particular relevance	"X"	document of particular relevance; the claimed invention cannot be considered novel or cannot be considered to involve an inventive step when the document is taken alone
"E" earlier document published on or after the international filing date	"Y"	document of particular relevance; the claimed invention cannot be considered to involve an inventive step when the document is combined with one or more other such documents, such combination being obvious to a person skilled in the art
"L" document which may throw doubts on priority claim(s) or which is cited to establish the publication date of another citation or other special reason (as specified)	"Z"	document member of the same patent family
"O" document referring to an oral disclosure, use, exhibition or other means		
"P" document published prior to the international filing date but later than the priority date claimed		
Date of the actual completion of the international search 13 SEPTEMBER 1995	Date of mailing of the international search report 17 NOV 1995	
Name and mailing address of the ISA/US Commissioner of Patents and Trademarks Box PCT Washington, D.C. 20231 Facsimile No. (703) 305-3230	Authorized officer <i>B. Hadden</i> HUY D. VU Telephone No. (703) 308-6602	

INTERNATIONAL SEARCH REPORT

International application No.
PCT/US95/08159

Box I Observations where certain claims were found unsearchable (Continuation of item 1 of first sheet)

This international report has not been established in respect of certain claims under Article 17(2)(a) for the following reasons:

- 1. Claims Nos.:
because they relate to subject matter not required to be searched by this Authority, namely:

- 2. Claims Nos.:
because they relate to parts of the international application that do not comply with the prescribed requirements to such an extent that no meaningful international search can be carried out, specifically:

- 3. Claims Nos.:
because they are dependent claims and are not drafted in accordance with the second and third sentences of Rule 6.4(a).

Box II Observations where unity of invention is lacking (Continuation of item 2 of first sheet)

This International Searching Authority found multiple inventions in this international application, as follows:

Telephone Practice

- I. Claims 1-7, 18-20, 26-27 and 30, drawn to an apparatus for exchanging information packets between plurality of modular expandable units over two transmission media. (375/260)
- II. Claims 8-17, drawn to a method for publishing directory entries and publisher address. (375/260)
- III. Claims 21-25, 28-29 and 31, drawn to a bus transmission system having a data bus and a separate control bus. (370/85.11)

- 1. As all required additional search fees were timely paid by the applicant, this international search report covers all searchable claims.
- 2. As all searchable claims could be searched without effort justifying an additional fee, this Authority did not invite payment of any additional fee.
- 3. As only some of the required additional search fees were timely paid by the applicant, this international search report covers only those claims for which fees were paid, specifically claims Nos.:

- 4. No required additional search fees were timely paid by the applicant. Consequently, this international search report is restricted to the invention first mentioned in the claims; it is covered by claims Nos.:

Remark on Protest

- The additional search fees were accompanied by the applicant's protest.
- No protest accompanied the payment of additional search fees.

PCT

WORLD INTELLECTUAL PROPERTY ORGANIZATION
International Bureau



INTERNATIONAL APPLICATION PUBLISHED UNDER THE PATENT COOPERATION TREATY (PCT)

<p>(51) International Patent Classification ⁶ : H04L 9/00</p>	<p>A1</p>	<p>(11) International Publication Number: WO 97/26732 (43) International Publication Date: 24 July 1997 (24.07.97)</p>
<p>(21) International Application Number: PCT/US97/00651 (22) International Filing Date: 16 January 1997 (16.01.97) (30) Priority Data: 08/587,943 17 January 1996 (17.01.96) US (71) Applicant: THE DICE COMPANY [US/US]; 20191 E. Country Club Drive, Townhouse 4, Aventura, FL 33180 (US). (72) Inventors: MOSKOWITZ, Scott, A.; 20191 E. Country Club Drive, Townhouse 4, Aventura, FL 33180 (US). COOPERMAN, Marc; 2929 Ramona, Palo Alto, CA 94306 (US). (74) Agents: ALTMILLER, John, C. et al.; Kenyon & Kenyon, 1025 Connecticut Avenue, N.W., Washington, DC 20036 (US).</p>		<p>(81) Designated States: AL, AU, BA, BB, BG, BR, CA, CN, CU, CZ, EE, GE, HU, IL, IS, JP, KP, KR, LC, LK, LR, LT, LV, MG, MK, MN, MX, NO, NZ, PL, RO, SG, SI, SK, TR, TT, UA, UZ, VN, ARIPO patent (KE, LS, MW, SD, SZ, UG), Eurasian patent (AM, AZ, BY, KG, KZ, MD, RU, TJ, TM), European patent (AT, BE, CH, DE, DK, ES, FI, FR, GB, GR, IE, IT, LU, MC, NL, PT, SE), OAPI patent (BF, BJ, CF, CG, CI, CM, GA, GN, ML, MR, NE, SN, TD, TG).</p> <p>Published <i>With international search report.</i></p>
<p>(54) Title: METHOD FOR STEGA-CIPHER PROTECTION OF COMPUTER CODE</p>		
<p>(57) Abstract</p> <p>A method for protecting computer code copyrights by encoding the code into a data resource with a digital watermark. The digital watermark contains licensing information interwoven with essential code resources encoded into data resources. The result is that while an application program can be copied in an uninhibited manner, only the licensed user having the license code can access essential code resources to operate the program and any descendant copies bear the required license code.</p>		

FOR THE PURPOSES OF INFORMATION ONLY

Codes used to identify States party to the PCT on the front pages of pamphlets publishing international applications under the PCT.

AM	Armenia	GB	United Kingdom	MW	Malawi
AT	Austria	GE	Georgia	MX	Mexico
AU	Australia	GN	Guinea	NE	Niger
BB	Barbados	GR	Greece	NL	Netherlands
BE	Belgium	HU	Hungary	NO	Norway
BF	Burkina Faso	IE	Ireland	NZ	New Zealand
BG	Bulgaria	IT	Italy	PL	Poland
BJ	Benin	JP	Japan	PT	Portugal
BR	Brazil	KE	Kenya	RO	Romania
BY	Belarus	KG	Kyrgystan	RU	Russian Federation
CA	Canada	KP	Democratic People's Republic of Korea	SD	Sudan
CF	Central African Republic	KR	Republic of Korea	SE	Sweden
CG	Congo	KZ	Kazakhstan	SG	Singapore
CH	Switzerland	LI	Liechtenstein	SI	Slovenia
CI	Côte d'Ivoire	LK	Sri Lanka	SK	Slovakia
CM	Cameroon	LR	Liberia	SN	Senegal
CN	China	LT	Lithuania	SZ	Swaziland
CS	Czechoslovakia	LU	Luxembourg	TD	Chad
CZ	Czech Republic	LV	Latvia	TG	Togo
DE	Germany	MC	Monaco	TJ	Tajikistan
DK	Denmark	MD	Republic of Moldova	TT	Trinidad and Tobago
EE	Estonia	MG	Madagascar	UA	Ukraine
ES	Spain	ML	Mali	UG	Uganda
FI	Finland	MN	Mongolia	US	United States of America
FR	France	MR	Mauritania	UZ	Uzbekistan
GA	Gabon			VN	Viet Nam

METHOD FOR STEGA-CIPHER PROTECTION OF COMPUTER CODEFIELD OF INVENTION

With the advent of computer networks and digital
5 multimedia, protection of intellectual property has
become a prime concern for creators and publishers of
digitized copies of copyrightable works, such as musical
recordings, movies, video games, and computer software.
One method of protecting copyrights in the digital
10 domain is to use "digital watermarks."

The prior art includes copy protection systems
attempted at many stages in the development of the
software industry. These may be various methods by
which a software engineer can write the software in a
15 clever manner to determine if it has been copied, and if
so to deactivate itself. Also included are undocumented
changes to the storage format of the content. Copy
protection was generally abandoned by the software
industry, since pirates were generally just as clever as
20 the software engineers and figured out ways to modify
the software and deactivate the protection. The cost of
developing such protection was not justified considering
the level of piracy which occurred despite the copy
protection.

25 Other methods for protection of computer software
include the requirement of entering certain numbers or
facts that may be included in a packaged software's
manual, when prompted at start-up. These may be

overcome if copies of the manual are distributed to unintended users, or by patching the code to bypass these measures. Other methods include requiring a user to contact the software vendor and to receive "keys" for
5 unlocking software after registration attached to some payment scheme, such as credit card authorization. Further methods include network-based searches of a user's hard drive and comparisons between what is registered to that user and what is actually installed
10 on the user's general computing device. Other proposals, by such parties as AT&T's Bell Laboratories, use "kerning" or actual distance in pixels, in the rendering of text documents, rather than a varied number of ASCII characters. However, this approach can often
15 be defeated by graphics processing analogous to sound processing, which randomizes that information. All of these methods require outside determination and verification of the validity of the software license.

Digital watermarks can be used to mark each
20 individual copy of a digitized work with information identifying the title, copyright holder, and even the licensed owner of a particular copy. When marked with licensing and ownership information, responsibility is created for individual copies where before there was
25 none. Computer application programs can be watermarked by watermarking digital content resources used in conjunction with images or audio data. Digital watermarks can be encoded with random or pseudo random keys, which act as secret maps for locating the
30 watermarks. These keys make it impossible for a party to find the watermark without having the key. In addition, the encoding method can be enhanced to force a party to cause damage to a watermarked data stream when trying to erase a random-key watermark. Digital
35 watermarks are described in "Steganographic Method and Device" - The DICE Company, Serial No. 08/489,172, the disclosure of which is hereby incorporated by reference.

Other information is disclosed in "Technology: Digital Commerce", Denise Caruso, New York Times, August 7, 1995; and "Copyrighting in the Information Age", Harley Ungar, ONLINE MARKETPLACE, September 1995, Jupiter

5 Communications.

Additionally, other methods for hiding information signals in content signals, are disclosed in U.S. Patent No. 5,319,735 - Preuss et al. and U.S. Patent No. 5,379,345 - Greenberg.

10 It is desirable to use a "stega-cipher" or watermarking process to hide the necessary parts or resources of the executable object code in the digitized sample resources. It is also desirable to further modify the underlying structure of an executable
15 computer application such that it is more resistant to attempts at patching and analysis by memory capture. A computer application seeks to provide a user with certain utilities or tools, that is, users interact with a computer or similar device to accomplish various tasks
20 and applications provide the relevant interface. Thus, a level of authentication can also be introduced into software, or "digital products," that include digital content, such as audio, video, pictures or multimedia, with digital watermarks. Security is maximized because
25 erasing this code watermark without a key results in the destruction of one or more essential parts of the underlying application, rendering the "program" useless to the unintended user who lacks the appropriate key. Further, if the key is linked to a license code by means
30 of a mathematical function, a mechanism for identifying the licensed owner of an application is created.

It is also desirable to randomly reorganize program memory structure intermittently during program run time, to prevent attempts at memory capture or object code
35 analysis aimed at eliminating licensing or ownership information, or otherwise modifying, in an unintended manner, the functioning of the application.

In this way, attempts to capture memory to determine underlying functionality or provide a "patch" to facilitate unauthorized use of the "application," or computer program, without destroying the functionality and thus usefulness of a copyrightable computer program can be made difficult or impossible.

It is thus the goal of the present invention to provide a higher level of copyright security to object code on par with methods described in digital watermarking systems for digitized media content such as pictures, audio, video and multimedia content in its multifarious forms, as described in previous disclosures, "Steganographic Method and Device" and "Human Assisted Random Key Generation and Application for Digital Watermark System", filed on even date herewith, the disclosure of which is hereby incorporated by reference.

It is a further goal of the present invention to establish methods of copyright protection that can be combined with such schemes as software metering, network distribution of code and specialized protection of software that is designed to work over a network, such as that proposed by Sun Microsystems in their HotJava browser and Java programming language, and manipulation of application code in proposed distribution of documents that can be exchanged with resources or the look and feel of the document being preserved over a network. Such systems are currently being offered by companies including Adobe, with their Acrobat software. This latter goal is accomplished primarily by means of the watermarking of font, or typeface, resources included in applications or documents, which determine how a bitmap representation of the document is ultimately drawn on a presentation device.

The present invention includes an application of the technology of "digital watermarks." As described in previous disclosures, "Steganographic Method and

Device" and "Human Assisted Random Key Generation and Application for Digital Watermark System," watermarks are particularly suitable to the identification, metering, distributing and authenticating digitized content such as pictures, audio, video and derivatives thereof under the description of "multimedia content." Methods have been described for combining both cryptographic methods, and steganography, or hiding something in plain view. Discussions of these technologies can be found in Applied Cryptography by Bruce Schneier and The Code Breakers by David Kahn. For more information on prior art public-key cryptosystems see US Pat No 4,200,770 Diffie-Hellman, 4,218,582 Hellman, 4,405,829 RSA, 4,424,414 Hellman Pohlig. Computer code, or machine language instructions, which are not digitized and have zero tolerance for error, must be protected by derivative or alternative methods, such as those disclosed in this invention, which focuses on watermarking with "keys" derived from license codes or other ownership identification information, and using the watermarks encoded with such keys to hide an essential subset of the application code resources.

SUMMARY OF THE INVENTION

It is thus a goal of the present invention, to provide a level of security for executable code on similar grounds as that which can be provided for digitized samples. Furthermore, the present invention differs from the prior art in that it does not attempt to stop copying, but rather, determines responsibility for a copy by ensuring that licensing information must be preserved in descendant copies from an original. Without the correct license information, the copy cannot function.

An improvement over the art is disclosed in the present invention, in that the software itself is a set of commands, compiled by software engineer, which can be

configured in such a manner as to tie underlying
functionality to the license or authorization of the
copy in possession by the user. Without such
verification, the functions sought out by the user in
5 the form of software cease to properly work. Attempts
to tamper or "patch" substitute code resources can be
made highly difficult by randomizing the location of
said resources in memory on an intermittent basis to
resist most attacks at disabling the system.

10

DETAILED DESCRIPTION

An executable computer program is variously
referred to as an application, from the point of view of
a user, or executable object code from the point of view
15 of the engineer. A collection of smaller, atomic (or
indivisible) chunks of object code typically comprise
the complete executable object code or application which
may also require the presence of certain data resources.
These indivisible portions of object code correspond
20 with the programmers' function or procedure
implementations in higher level languages, such as C or
Pascal. In creating an application, a programmer writes
"code" in a higher level language, which is then
compiled down into "machine language," or, the
25 executable object code, which can actually be run by a
computer, general purpose or otherwise. Each function,
or procedure, written in the programming language,
represents a self-contained portion of the larger
program, and implements, typically, a very small piece
30 of its functionality. The order in which the programmer
types the code for the various functions or procedures,
and the distribution of and arrangement of these
implementations in various files which hold them is
unimportant. Within a function or procedure, however,
35 the order of individual language constructs, which
correspond to particular machine instructions is
important, and so functions or procedures are considered

indivisible for purposes of this discussion. That is, once a function or procedure is compiled, the order of the machine instructions which comprise the executable object code of the function is important and their order
5 in the computer memory is of vital importance. Note that many "compilers" perform "optimizations" within functions or procedures, which determine, on a limited scale, if there is a better arrangement for executable instructions which is more efficient than that
10 constructed by the programmer, but does not change the result of the function or procedure. Once these optimizations are performed, however, making random changes to the order of instructions is very likely to "break" the function. When a program is compiled, then,
15 it consists of a collection of these sub-objects, whose exact order or arrangement in memory is not important, so long as any sub-object which uses another sub-object knows where in memory it can be found.

The memory address of the first instruction in one
20 of these sub-objects is called the "entry point" of the function or procedure. The rest of the instructions comprising that sub-object immediately follow from the entry point. Some systems may prefix information to the entry point which describes calling and return
25 conventions for the code which follows, an example is the Apple Macintosh Operating System (MacOS). These sub-objects can be packaged into what are referred to in certain systems as "code resources," which may be stored separately from the application, or shared with other
30 applications, although not necessarily. Within an application there are also data objects, which consist of some data to be operated on by the executable code. These data objects are not executable. That is, they do not consist of executable instructions. The data
35 objects can be referred to in certain systems as "resources."

When a user purchases or acquires a computer program, she seeks a computer program that "functions" in a desired manner. Simply, computer software is overwhelmingly purchased for its underlying
5 functionality. In contrast, persons who copy multimedia content, such as pictures, audio and video, do so for the entertainment or commercial value of the content. The difference between the two types of products is that
10 multimedia content is not generally interactive, but is instead passive, and its commercial value relates more on passive not interactive or utility features, such as those required in packaged software, set-top boxes, cellular phones, VCRs, PDAs, and the like. Interactive
15 digital products which include computer code may be mostly interactive but can also contain content to add to the interactive experience of the user or make the underlying utility of the software more aesthetically pleasing. It is a common concern of both of these
20 creators, both of interactive and passive multimedia products, that "digital products" can be easily and perfectly copied and made into unpaid or unauthorized copies. This concern is especially heightened when the underlying product is copyright protected and intended for commercial use.

25 The first method of the present invention described involves hiding necessary "parts" or code "resources" in digitized sample resources using a "digital watermarking" process, such as that described in the "Steganographic Method and Device" patent application.
30 The basic premise for this scheme is that there are a certain sub-set of executable code resources, that comprise an application and that are "essential" to the proper function of the application. In general, any code resource can be considered "essential" in that if
35 the program proceeds to a point where it must "call" the code resource and the code resource is not present in memory, or cannot be loaded, then the program fails.

However, the present invention uses a definition of "essential" which is more narrow. This is because, those skilled in the art or those with programming experience, may create a derivative program, not unlike the utility provided by the original program, by writing additional or substituted code to work around unavailable resources. This is particularly true with programs that incorporate an optional "plug-in architecture," where several code resources may be made optionally available at run-time. The present invention is also concerned with concentrated efforts by technically skilled people who can analyze executable object code and "patch" it to ignore or bypass certain code resources. Thus, for the present embodiment's purposes, "essential" means that the function which distinguishes this application from any other application depends upon the presence and use of the code resource in question. The best candidates for this type of code resources are NOT optional, or plug-in types, unless special care is taken to prevent work-arounds.

Given that there are one or more of these essential resources, what is needed to realize the present invention is the presence of certain data resources of a type which are amenable to the "stega-cipher" process described in the "Steganographic Method and Device" patent application. Data which consists of image or audio samples is particularly useful. Because this data consists of digital samples, digital watermarks can be introduced into the samples. What is further meant is that certain applications include image and audio samples which are important to the look and feel of the program or are essential to the processing of the application's functionality when used by the user. These computer programs are familiar to users of computers but also less obvious to users of other devices that run applications that are equivalent in

some measure of functionality to general purpose computers including, but not limited to, set-top boxes, cellular phones, "smart televisions," PDAs and the like. However, programs still comprise the underlying
5 "operating systems" of these devices and are becoming more complex with increases in functionality.

One method of the present invention is now discussed. When code and data resources are compiled and assembled into a precursor of an executable program
10 the next step is to use a utility application for final assembly of the executable application. The programmer marks several essential code resources in a list displayed by the utility. The utility will choose one or several essential code resources, and encode them
15 into one or several data resources using the steganographic process. The end result will be that these essential code resources are not stored in their own partition, but rather stored as encoded information in data resources. They are not accessible at run-time
20 without the key. Basically, the essential code resources that provide functionality in the final end-product, an executable application or computer program, are no longer easily and recognizably available for manipulation by those seeking to remove the underlying
25 copyright or license, or its equivalent information, or those with skill to substitute alternative code resources to "force" the application program to run as an unauthorized copy. For the encoding of the essential code resources, a "key" is needed. Such a key is
30 similar to those described in the "Steganographic Method and Device." The purpose of this scheme is to make a particular licensed copy of an application distinguishable from any other. It is not necessary to distinguish every instance of an application, merely
35 every instance of a license. A licensed user may then wish to install multiple copies of an application, legally or with authorization. This method, then, is to

choose the key so that it corresponds, is equal to, or is a function of, a license code or license descriptive information, not just a text file, audio clip or identifying piece of information as desired in digital watermarking schemes extant and typically useful to stand-alone, digitally sampled content. The key is necessary to access the underlying code, i.e., what the user understands to be the application program.

The assembly utility can be supplied with a key generated from a license code generated for the license in question. Alternatively, the key, possibly random, can be stored as a data resource and encrypted with a derivative of the license code. Given the key, it encodes one or several essential resources into one or several data resources. Exactly which code resources are encoded into which data resources may be determined in a random or pseudo random manner. Note further that the application contains a code resource which performs the function of decoding an encoded code resource from a data resource. The application must also contain a data resource which specifies in which data resource a particular code resource is encoded. This data resource is created and added at assembly time by the assembly utility. The application can then operate as follows:

- 1) when it is run for the first time, after installation, it asks the user for personalization information, which includes the license code. This can include a particular computer configuration;
- 2) it stores this information in a personalization data resource;
- 3) Once it has the license code, it can then generate the proper decoding key to access the essential code resources.

Note that the application can be copied in an uninhibited manner, but must contain the license code issued to the licensed owner, to access its essential code resources. The goal of the invention, copyright

protection of computer code and establishment of responsibility for copies, is thus accomplished.

This invention represents a significant improvement over prior art because of the inherent difference in use
5 of purely informational watermarks versus watermarks which contain executable object code. If the executable object code in a watermark is essential to an application which accesses the data which contains the watermark, this creates an all-or-none situation.
10 Either the user must have the extracted watermark, or the application cannot be used, and hence the user cannot gain full access to the presentation of the information in the watermark bearing data. In order to extract a digital watermark, the user must have a key.
15 The key, in turn, is a function of the license information for the copy of the software in question. The key is fixed prior to final assembly of the application files, and so cannot be changed at the option of the user. That, in turn, means the license
20 information in the software copy must remain fixed, so that the correct key is available to the software. The key and the license information are, in fact, interchangeable. One is merely more readable than the other. In the earlier developed "Steganographic Method
25 and Device," the possibility of randomization erasure attacks on digital watermarks was discussed. Simply, it is always possible to erase a digital watermark, depending on how much damage you are willing to do to the watermark-bearing content stream. The present
30 invention has the significant advantage that you must have the watermark to be able to use the code it contains. If you erase the watermark you have lost a key piece of the functionality of the application, or even the means to access the data which bear the
35 watermark.

A preferred embodiment would be implemented in an embedded system, with a minimal operating system and

memory. No media playing "applets," or smaller sized applications as proposed in new operating environments envisioned by Sun Microsystems and the advent of Sun's Java operating system, would be permanently stored in
5 the system, only the bare necessities to operate the device, download information, decode watermarks and execute the applets contained in them. When an applet is finished executing, it is erased from memory. Such a system would guarantee that content which did not
10 contain readable watermarks could not be used. This is a powerful control mechanism for ensuring that content to be distributed through such a system contains valid watermarks. Thus, in such networks as the Internet or set-top box controlled cable systems, distribution and
15 exchange of content would be made more secure from unauthorized copying to the benefit of copyright holders and other related parties. The system would be enabled to invalidate, by default, any content which has had its watermark(s) erased, since the watermark conveys, in
20 addition to copyright information, the means to fully access, play, record or otherwise manipulate, the content.

A second method according to the present invention is to randomly re-organize program memory structure to
25 prevent attempts at memory capture or object code analysis. The object of this method is to make it extremely difficult to perform memory capture-based analysis of an executable computer program. This analysis is the basis for a method of attack to defeat
30 the system envisioned by the present invention.

Once the code resources of a program are loaded into memory, they typically remain in a fixed position, unless the computer operating system finds it necessary to rearrange certain portions of memory during "system
35 time," when the operating system code, not application code, is running. Typically, this is done in low memory systems, to maintain optimal memory utilization. The

MacOS for example, uses Handles, which are double-indirect pointers to memory locations, in order to allow the operating system to rearrange memory transparently, underneath a running program. If a computer program
5 contains countermeasures against unlicensed copying, a skilled technician can often take a snapshot of the code in memory, analyze it, determine which instructions comprise the countermeasures, and disable them in the stored application file, by means of a "patch." Other
10 applications for designing code that moves to prevent scanning-tunnelling microscopes, and similar high sensitive hardware for analysis of electronic structure of microchips running code, have been proposed by such parties as Wave Systems. Designs of Wave Systems'
15 microchip are intended for preventing attempts by hackers to "photograph" or otherwise determine "burn in" to microchips for attempts at reverse engineering. The present invention seeks to prevent attempts at understanding the code and its organization for the
20 purpose of patching it. Unlike systems such as Wave Systems', the present invention seeks to move code around in such a manner as to complicate attempts by software engineers to reengineer a means to disable the methods for creating licensed copies on any device that
25 lacks "trusted hardware." Moreover, the present invention concerns itself with any application software that may be used in general computing devices, not chipsets that are used in addition to an underlying computer to perform encryption. Wave Systems' approach
30 to security of software, if interpreted similarly to the present invention, would dictate separate microchip sets for each piece of application software that would be tamperproof. This is not consistent with the economics of software and its distribution.

35 Under the present invention, the application contains a special code resource which knows about all the other code resources in memory. During execution

time, this special code resource, called a "memory scheduler," can be called periodically, or at random or pseudo random intervals, at which time it intentionally shuffles the other code resources randomly in memory, so that someone trying to analyze snapshots of memory at various intervals cannot be sure if they are looking at the same code or organization from one "break" to the next. This adds significant complexity to their job. The scheduler also randomly relocates itself when it is finished. In order to do this, the scheduler would have to first copy itself to a new location, and then specifically modify the program counter and stack frame, so that it could then jump into the new copy of the scheduler, but return to the correct calling frame. Finally, the scheduler would need to maintain a list of all memory addresses which contain the address of the scheduler, and change them to reflect its new location.

The methods described above accomplish the purposes of the invention - to make it hard to analyze captured memory containing application executable code in order to create an identifiable computer program or application that is different from other copies and is less susceptible to unauthorized use by those attempting to disable the underlying copyright protection system. Simply, each copy has particular identifying information making that copy different from all other copies.

What is Claimed Is:

- 1 1. A method of associating executable object code with
2 a digital sample stream by means of a digital watermark
3 wherein the digital watermark contains executable object
4 code and is encoded into the digital sample stream.
- 1 2. The method of claim 1 wherein a key to access the
2 digital watermark is a function of a collection of
3 license information pertaining to the software which is
4 accessing the watermark
5 where license information consists of one or more
6 of the following items:
7 Owning Organization name;
8 Personal Owner name;
9 Owner Address;
10 License code;
11 Software serialization number;
12 Distribution parameters;
13 Appropriate executable general computing
14 device architecture;
15 Pricing; and
16 Software Metering details.
- 1 3. The method of claim 1 further comprising the step
2 of transmitting the digital sample stream, via a
3 transmission means, from a publisher to a subscriber
4 wherein transmission means can selected from the
5 group of
6 soft sector magnetic disk media;
7 hard sector magnetic disk media;
8 magnetic tape media;
9 optical disc media;
10 Digital Video Disk media;
11 magneto-optical disk media;
12 memory cartridge;
13 telephone lines;

14 SCSI;
15 Ethernet or Token Ring Network;
16 ISDN;
17 ATM network;
18 TCP/IP network;
19 analog cellular network;
20 digital cellular network;
21 wireless network;
22 digital satellite;
23 cable network;
24 fiber optic network; and
25 electric powerline network.

1 4. The method of claim 1 where the object code to be
2 encoded is comprised of series of executable machine
3 instructions which perform the function of
4 processing a digital sample stream for the purpose
5 of modifying it or playing the digital sample stream.

1 5. The method of claim 3 further comprising the steps
2 of:
3 decoding said digital watermark and extracting
4 object code;
5 loading object code into computer memory for the
6 purpose of execution;
7 executing said object code in order to process said
8 digital sample stream for the purpose of playback.

1 6. A method of assembling an application to be
2 protected by watermark encoding of essential resources
3 comprising the steps of:
4 assembling a list of identifiers of essential
5 code resources of an application where identifiers allow
6 the code resource to be accessed and loaded into memory;
7 providing license information on the
8 licensee who is to receive an individualized copy of the
9 application;

10 storing license information in a
11 personalization resource which is added to the list of
12 application data resources;

13 generating a digital watermark key from
14 the license information; using the key as a pseudo-
15 random number string to select a list of suitable
16 digital sample data resources, the list of essential
17 code resources, and a mapping of which essential code
18 resources are to be watermarked into which data
19 resources;

20 storing the map, which is a list of
21 paired code and data resource identifiers, as a data
22 resource, which is added to the application;

23 adding a digital watermark decoder code
24 resource to the application, to provide a means for
25 extracting essential code resource from data resources,
26 according to the map;

27 processing the map list and encoding
28 essential code resources into digital sample data
29 resources with a digital watermark encoder;

30 removing self-contained copies of the
31 essential code resources which have been watermarked
32 into data resources; and

33 combining all remaining code and data
34 resources into a single application or installer.

1 7. A method of intermittently relocating application
2 code resources in computer memory, in order to prevent,
3 discourage, or complicate attempts at memory capture
4 based code analysis.

1 8. The method of claim 7 additionally comprising the
2 step of
3 assembling a list of identifiers of code resources
4 of an application where identifiers allow the code
5 resource to be accessed and loaded into memory.

1 9. The method of claim 8 additionally comprising the
2 step of modifying application program structure to make
3 all code resource calls indirectly, through the memory
4 scheduler, which looks up code resources in its list and
5 dispatches calls.

1 10. The method of claim 9 additionally comprising the
2 step of intermittently rescheduling or shuffling all
3 code resources prior to or following the dispatch of a
4 code resource call through the memory scheduler.

1 11. The method of claim 10 additionally comprised of
2 the step of the memory scheduler copying itself to a new
3 location in memory.

1 12. The method of claim 11 additionally comprising the
2 step of modifying the stack frame, program counter, and
3 memory registers of the CPU to cause the scheduler to
4 jump to the next instruction comprising the scheduler,
5 in the copy, to erase the previous memory instance of
6 the scheduler, and changing all memory references to the
7 scheduler to reflect its new location, and to return
8 from the copy of the scheduler to the frame which called
9 the previous copy of the scheduler.

INTERNATIONAL SEARCH REPORT

International application No.
PCT/US97/00651

A. CLASSIFICATION OF SUBJECT MATTER IPC(6) :H04L 9/00 US CL : 380/54 According to International Patent Classification (IPC) or to both national classification and IPC		
B. FIELDS SEARCHED Minimum documentation searched (classification system followed by classification symbols) U.S. : 380/54, 2, 4, 9, 21, 23, 25, 28, 49, 50, 59; 283/73, 113, 17 Documentation searched other than minimum documentation to the extent that such documents are included in the fields searched Electronic data base consulted during the international search (name of data base and, where practicable, search terms used)		
C. DOCUMENTS CONSIDERED TO BE RELEVANT		
Category*	Citation of document, with indication, where appropriate, of the relevant passages	Relevant to claim No.
Y	US 5,349,655 A (MANN) 20 September 1994, see Abstract.	1
X	US 4,262,329 A (BRIGHT et al) 14 April 1981, see Abstract.	7
<input type="checkbox"/> Further documents are listed in the continuation of Box C. <input type="checkbox"/> See patent family annex.		
* Special categories of cited documents: "A" document defining the general state of the art which is not considered to be of particular relevance "E" earlier document published on or after the international filing date "L" document which may throw doubts on priority claim(s) or which is cited to establish the publication date of another citation or other special reason (as specified) "O" document referring to an oral disclosure, use, exhibition or other means "P" document published prior to the international filing date but later than the priority date claimed "T" later document published after the international filing date or priority date and not in conflict with the application but cited to understand the principle or theory underlying the invention "X" document of particular relevance; the claimed invention cannot be considered novel or cannot be considered to involve an inventive step when the document is taken alone "Y" document of particular relevance; the claimed invention cannot be considered to involve an inventive step when the document is combined with one or more other such documents, such combination being obvious to a person skilled in the art "&" document member of the same patent family		
Date of the actual completion of the international search 04 APRIL 1997		Date of mailing of the international search report 29 APR 1997
Name and mailing address of the ISA/US Commissioner of Patents and Trademarks Box PCT Washington, D.C. 20231 Facsimile No. (703) 305-3230		Authorized officer <i>Bernarr Earl Gregory</i> BERNARR EARL GREGORY Telephone No. (703) 306-4153

(12) INTERNATIONAL APPLICATION PUBLISHED UNDER THE PATENT COOPERATION TREATY (PCT)

(19) World Intellectual Property Organization
International Bureau



(43) International Publication Date
10 January 2002 (10.01.2002)

PCT

(10) International Publication Number
WO 02/03385 A1

- (51) International Patent Classification⁷: G11B 20/00, G06F 1/00
- (21) International Application Number: PCT/US00/18411
- (22) International Filing Date: 5 July 2000 (05.07.2000)
- (25) Filing Language: English
- (26) Publication Language: English
- (71) Applicant and
- (72) Inventor: MOSKOWITZ, Scott, A. [US/US]; 16711 Collins Avenue #2505, Miami, FL 33160 (US).
- (74) Agents: CHAPMAN, Floyd, B. et al.; Wiley Rein & Fielding, Intellectual Property Department, 1776 K Street, N.W., Washington, DC 20006 (US).
- (81) Designated States (national): AE, AL, AM, AT, AU, AZ, BA, BB, BG, BR, BY, CA, CH, CN, CR, CU, CZ, DE, DK,

DM, EE, ES, FI, GB, GD, GE, GH, GM, HR, HU, ID, IL, IN, IS, JP, KE, KG, KP, KR, KZ, LC, LK, LR, LS, LT, LU, LV, MA, MD, MG, MK, MN, MW, MX, NO, NZ, PL, PT, RO, RU, SD, SE, SG, SI, SK, SL, TJ, TM, TR, TT, TZ, UA, UG, UZ, VN, YU, ZA, ZW.

- (84) Designated States (regional): ARIPO patent (GH, GM, KE, LS, MW, MZ, SD, SL, SZ, TZ, UG, ZW), Eurasian patent (AM, AZ, BY, KG, KZ, MD, RU, TJ, TM), European patent (AT, BE, CH, CY, DE, DK, ES, FI, FR, GB, GR, IE, IT, LU, MC, NL, PT, SE), OAPI patent (BF, BJ, CF, CG, CI, CM, GA, GN, GW, ML, MR, NE, SN, TD, TG).

Published:
— with international search report

For two-letter codes and other abbreviations, refer to the "Guidance Notes on Codes and Abbreviations" appearing at the beginning of each regular issue of the PCT Gazette.

(54) Title: COPY PROTECTION OF DIGITAL DATA COMBINING STEGANOGRAPHIC AND CRYPTOGRAPHIC TECHNIQUES



WO 02/03385 A1

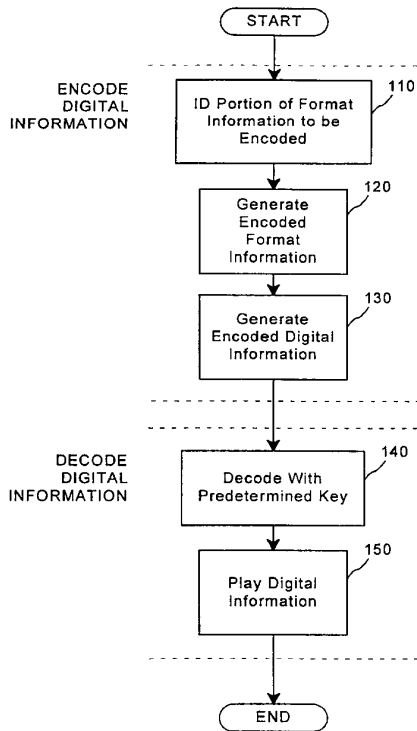

(57) Abstract: A method for combining transfer functions with predetermined key creation. In one embodiment, digital information, including a digital sample and format information, is protected by identifying and encoding a portion of the format information. Encoded digital information, including the digital sample and the encoded format information generated to protect the original digital information. In another embodiment, a digital signal, including digital samples in a file format having an inherent granularity, is protected by creating a predetermined key. The predetermined key is comprised of a transfer function-based mask set to manipulate data at the inherent granularity of the file format of the underlying digitized samples.

COPY PROTECTION OF DIGITAL DATA COMBINING STEGANOGRAPHIC AND CRYPTOGRAPHIC TECHNIQUES

BACKGROUND OF THE INVENTION

5 Increasingly, commercially valuable information is being created and stored in “digital” form. For example, music, photographs and video can all be stored and transmitted as a series of numbers, such as 1's and 0's. Digital techniques let the original information be recreated in a very accurate manner. Unfortunately, digital techniques also let the information be easily copied without the information
10 owner's permission.

 Because unauthorized copying is clearly a disincentive to the digital distribution of valuable information, it is important to establish responsibility for copies and derivative copies of such works. For example, if each authorized digital copy of a popular song is identified with a unique number, any unauthorized copy of
15 the song would also contain the number. This would allow the owner of the information, such as a song publisher, to investigate who made the unauthorized copy. Unfortunately, it is possible that the unique number could be erased or altered if it is simply tacked on at the beginning or end of the digital information.

 As will be described, known digital “watermark” techniques give
20 creators and publishers of digitized multimedia content localized, secured identification and authentication of that content. In considering the various forms of multimedia content, such as “master,” stereo, National Television Standards Committee (NTSC) video, audio tape or compact disc, tolerance of quality will vary with individuals and affect the underlying commercial and aesthetic value of the
25 content. For example, if a digital version of a popular song sounds distorted, it will be less valuable to users. It is therefore desirable to embed copyright, ownership or purchaser information, or some combination of these and related data, into the content in a way that will damage the content if the watermark is removed without authorization.

30 To achieve these goals, digital watermark systems insert ownership information in a way that causes little or no noticeable effects, or “artifacts,” in the underlying content signal. For example, if a digital watermark is inserted into a

digital version of a song, it is important that a listener not be bothered by the slight changes introduced by the watermark. It is also important for the watermark technique to maximize the encoding level and "location sensitivity" in the signal to force damage to the content signal when removal is attempted. Digital watermarks address many of these concerns, and research in the field has provided extremely robust and secure implementations.

What has been overlooked in many applications described in the art, however, are systems which closely mimic distribution of content as it occurs in the real world. For instance, many watermarking systems require the original un-watermarked content signal to enable detection or decode operations. These include highly publicized efforts by NEC, Digimarc and others. Such techniques are problematic because, in the real world, original master copies reside in a rights holders vaults and are not readily available to the public.

With much activity overly focused on watermark survivability, the security of a digital watermark is suspect. Any simple linear operation for encoding information into a signal may be used to erase the embedded signal by inverting the process. This is not a difficult task, especially when detection software is a plug-in freely available to the public, such as with Digimarc. In general, these systems seek to embed cryptographic information, not cryptographically embed information into target media content.

Other methods embed ownership information that is plainly visible in the media signal, such as the method described in US Patent No. 5,530,739 to Braudaway et al. The system described in Braudaway protects a digitized image by encoding a visible watermark to deter piracy. Such an implementation creates an immediate weakness in securing the embedded information because the watermark is plainly visible. Thus, no search for the embedded signal is necessary and the watermark can be more easily removed or altered. For example, while certainly useful to some rights owners, simply placing the symbol "©" in the digital information would only provide limited protection. Removal by adjusting the brightness of the pixels forming the "©" would not be difficult with respect to the computational resources required.

Other relevant prior art includes US Patents No. 4,979,210 and 5,073,925 to Nagata et al., which encodes information by modulating an audio signal in the amplitude/time domain. The modulations introduced in the Nagata process carry a “copy/don't copy” message, which is easily found and circumvented by one skilled in the art. The granularity of encoding is fixed by the amplitude and frequency modulation limits required to maintain inaudibility. These limits are relatively low, making it impractical to encode more information using the Nagata process.

Although US Patent No. 5,664,018 to Leighton describes a means to prevent collusion attacks in digital watermarks, the disclosed method may not actually provide the security described. For-example, in cases where the watermarking technique is linear, the “insertion envelope” or “watermarking space” is well-defined and thus susceptible to attacks less sophisticated than collusion by unauthorized parties. Over-encoding at the watermarking encoding level is but one simple attack in such linear implementations. Another consideration not made by Leighton is that commercially-valuable content may already exist in a un-watermarked form somewhere, easily accessible to potential pirates, gutting the need for any type of collusive activity. Digitally signing the embedded signal with preprocessing of watermark data is more likely to prevent successful collusion. Furthermore, a “baseline” watermark as disclosed is quite subjective. It is simply described elsewhere in the art as the “perceptually significant” regions of a signal. Making a watermarking function less linear or inverting the insertion of watermarks would seem to provide the same benefit without the additional work required to create a “baseline” watermark. Indeed, watermarking algorithms should already be capable of defining a target insertion envelope or region without additional steps. What is evident is the Leighton patent does not allow for initial prevention of attacks on an embedded watermark as the content is visibly or audibly unchanged.

It is also important that any method for providing security also function with broadcasting media over networks such as the Internet, which is also referred to as “streaming.” Commercial “plug-in” products such as RealAudio and RealVideo, as well as applications by vendors VDONet and Xtreme, are common in such network environments. Most digital watermark implementations focus on

common file base signals and fail to anticipate the security of streamed signals. It is desirable that any protection scheme be able to function with a plug-in player without advanced knowledge of the encoded media stream.

5 Other technologies focus solely on file-based security. These technologies illustrate the varying applications for security that must be evaluated for different media and distribution environments. Use of cryptolopes or cryptographic containers, as proposed by IBM in its Cryptolope product, and InterTrust, as described in U.S. Patents No. 4,827,508, 4,977,594, 5,050,213 and 5,410,598, may discourage certain forms of piracy. Cryptographic containers, 10 however, require a user to subscribe to particular decryption software to decrypt data. IBM's InfoMarket and InterTrust's DigiBox, among other implementations, provide a generalized model and need proprietary architecture to function. Every user must have a subscription or registration with the party which encrypts the data. Again, as a form of general encryption, the data is scrambled or encrypted without 15 regard to the media and its formatting. Finally, control over copyrights or other neighboring rights is left with the implementing party, in this case, IBM, InterTrust or a similar provider. Methods similar to these "trusted systems" exist, and Cerberus Central Limited and Liquid Audio, among a number of companies, offer systems which may functionally be thought of as subsets of IBM and InterTrust's 20 more generalized security offerings. Both Cerberus and Liquid Audio propose proprietary player software which is registered to the user and "locked" in a manner parallel to the locking of content that is distributed via a cryptographic container. The economic trade-off in this model is that users are required to use each respective companies' proprietary player to play or otherwise manipulate content that is 25 downloaded. If, as is the case presently, most music or other media is not available via these proprietary players and more companies propose non-compatible player formats, the proliferation of players will continue. Cerberus and Liquid Audio also by way of extension of their architectures provide for "near-CD quality" but proprietary compression. This requirement stems from the necessity not to allow 30 content that has near-identical data make-up to an existing consumer electronic standard, in Cerberus and Liquid Audio's case the so-called Red Book audio CD standard of 16 bit 44.1 kHz, so that comparisons with the proprietary file may not

yield how the player is secured. Knowledge of the player's file format renders its security ineffective as a file may be replicated and played on any common player, not the intended proprietary player of the provider of previously secured and uniquely formatted content. This is the parallel weakness to public key crypto-
5 systems which have gutted security if enough plain text and cipher text comparisons enable a pirate to determine the user's private key.

Many approaches to digital watermarking leave detection and decoding control with the implementing party of the digital watermark, not the creator of the work to be protected. A set of secure digital watermark
10 implementations address this fundamental control issue forming the basis of key-based approaches. These are covered by the following patents and pending applications, the entire disclosures of which are hereby incorporated by reference: US Patent No. 5,613, 004 entitled "Steganographic Method and Device" and its derivative US patent application Serial No. 08/775,216, US patent application Serial
15 No. 08/587,944 entitled "Human Assisted Random Key Generation and Application for Digital Watermark System," US Patent Application Serial No. 08/587,943 entitled "Method for Stega-Cipher Protection of Computer Code," US patent application Serial No. 08/677,435 entitled "Optimization Methods for the Insertion, Protection, and Detection of Digital Watermarks in Digitized Data," and US Patent
20 Application Serial No. 08/772,222 entitled "Z-Transform Implementation of Digital Watermarks." Public key crypto-systems are described in US Patents No. 4,200,770, 4,218,582, 4,405,829 and 4,424,414, the entire disclosures of which are also hereby incorporated by reference.

In particular, an improved protection scheme is described in "Method
25 for Stega-Cipher Protection of Computer Code," US patent application Serial No. 08/587,943. This technique uses the key-based insertion of binary executable computer code within a content signal that is subsequently, and necessarily, used to play or otherwise manipulate the signal in which it is encoded. With this system, however, certain computational requirements, such as one digital player per digital
30 copy of content, may be necessitated. For instance, a consumer may download many copies of watermarked content. With this technique, the user would also be downloading as many copies of the digital player program. While this form of

security may be desirable for some applications, it is not appropriate in many circumstances. Finally, even when digital information is distributed in encoded form, it may be desirable to allow unauthorized users to play the information with a digital player, perhaps with a reduced level of quality. For example, a popular song
5 may be encoded and freely distributed in encoded form to the public. The public, perhaps using commonly available plug-in digital players, could play the encoded content and hear the music in some degraded form. The music may sound choppy, or fuzzy or be degraded in some other way. This lets the public decide, based on the available lower quality version of the song, if they want to purchase a key from the
10 publisher to decode, or "clean-up," the content. Similar approaches could be used to distribute blurry pictures or low quality video. Or even "degraded" text, in the sense that only authenticated portions of the text can be determined with the predetermined key or a validated digital signature for the intended message.

In view of the foregoing, it can be appreciated that a substantial need
15 exists for a method allowing encoded content to be played, with degraded quality, by a plug-in digital player, and solving the other problems discussed above.

SUMMARY OF THE INVENTION

The disadvantages of the art are alleviated to a great extent by a method for combining transfer functions with predetermined key creation. In one
20 embodiment, digital information, including a digital sample and format information, is protected by identifying and encoding a portion of the format information. Encoded digital information, including the digital sample and the encoded format information, is generated to protect the original digital information.

In another embodiment, a digital signal, including digital samples in a
25 file format having an inherent granularity, is protected by creating a predetermined key. The predetermined key is comprised of a transfer function-based mask set to manipulate data at the inherent granularity of the file format of the underlying digitized samples.

With these and other advantages and features of the invention that
30 will become hereinafter apparent, the nature of the invention may be more clearly understood by reference to the following detailed description of the invention, the appended claims and to the several drawings attached herein.

BRIEF DESCRIPTION OF THE DRAWINGS

FIG. 1 is a block flow diagram of a method for copy protection or authentication of digital information according to an embodiment of the present invention.

5 DETAILED DESCRIPTION

In accordance with an embodiment of the present invention, a method combines transfer functions with predetermined key creation. Increased security is achieved in the method by combining elements of “public-key steganography” with cryptographic protocols, which keep in-transit data secure by scrambling the data with “keys” in a manner that is not apparent to those with access to the content to be distributed. Because different forms of randomness are combined to offer robust, distributed security, the present invention addresses an architectural “gray space” between two important areas of security: digital watermarks, a subset of the more general art of steganography, and cryptography. One form of randomness exists in the mask sets that are randomly created to map watermark data into an otherwise unrelated digital signal. The second form of randomness is the random permutations of data formats used with digital players to manipulate the content with the predetermined keys. These forms can be thought of as the transfer function versus the mapping function inherent to digital watermarking processes.

20 According to an embodiment of the present invention, a predetermined, or randomly generated, key is used to scramble digital information in a way that is unlike known “digital watermark” techniques and public key cryptosystems. As used herein, a key is also referred to as a “mask set” which includes one or more random or pseudo-random series of bits. Prior to encoding, a mask can be generated by any cryptographically secure random generation process. A block cipher, such as a Data Encryption Standard (DES) algorithm, in combination with a sufficiently random seed value, such as one created using a Message Digest 5 (MD5) algorithm, emulates a cryptographically secure random bit generator. The keys are saved in a database, along with information matching them to the digital signal, for use in descrambling and subsequent viewing or playback. Additional file format or transfer property information is prepared and made available to the encoder, in a bit addressable manner. As well, any authenticating function can be

combined, such as Digital Signature Standard (DSS) or Secure Hash Algorithm (SHA).

Using the predetermined key comprised of a transfer function-based mask set, the data representing the original content is manipulated at the inherent
5 granularity of the file format of the underlying digitized samples. Instead of providing, or otherwise distributing, watermarked content that is not noticeably altered, a partially “scrambled” copy of the content is distributed. The key is necessary both to register the sought-after content and to descramble the content into its original form.

10 The present invention uses methods disclosed in “Method for Stega-Cipher Protection of Computer Code,” US Patent Application Serial No. 08/587,943, with respect to transfer functions related to the common file formats, such as PICT, TIFF, AIFF, WAV, etc. Additionally, in cases where the content has not been altered beyond being encoded with such functional data, it is possible for a
15 digital player to still play the content because the file format has not been altered. Thus, the encoded content could still be played by a plug-in digital player as discrete, digitally sampled signals, watermarked or not. That is, the structure of the file can remain basically unchanged by the watermarking process, letting common file format based players work with the “scrambled” content.

20 For example, the Compact Disc-Digital Audio (CD-DA) format stores audio information as a series of frames. Each frame contains a number of digital samples representing, for example, music, and a header that contains file format information. As shown in FIG. 1, according to an embodiment of the present invention some of the header information can be identified and “scrambled”
25 using the predetermined key at steps 110 to 130. The music samples can remain unchanged. Using this technique, a traditional CD-DA player will be able to play a distorted version of the music in the sample. The amount of distortion will depend on the way, and extent, that the header, or file format, information has been scrambled. It would also be possible to instead scramble some of the digital samples
30 while leaving the header information alone. In general, the digital signal would be protected by manipulating data at the inherent granularity, or “frames,” of the CD-

DA file format. To decode the information, a predetermined key is used before playing the digital information at steps 140 and 150.

5 A key-based decoder can act as a “plug-in” digital player of broadcast signal streams without foreknowledge of the encoded media stream. Moreover, the data format orientation is used to partially scramble data in transit to prevent unauthorized descrambled access by decoders that lack authorized keys. A distributed key can be used to unscramble the scrambled content because a decoder would understand how to process the key. Similar to on-the-fly decryption operations, the benefits inherent in this embodiment include the fact that the combination of watermarked content security, which is key-based, and the descrambling of the data, can be performed by the same key which can be a plurality of mask sets. The mask sets may include primary, convolution and message delimiter masks with file format data included. r

15 The creation of an optimized “envelope” for insertion of watermarks provides the basis of much watermark security, but is also a complementary goal of the present invention. The predetermined or random key that is generated is not only an essential map to access the hidden information signal, but is also the descrambler of the previously scrambled signal's format for playback or viewing.

20 In a system requiring keys for watermarking content and validating the distribution of the content, different keys may be used to encode different information while secure one way hash functions or one-time pads may be incorporated to secure the embedded signal. The same keys can be used to later validate the embedded digital signature, or even fully decode the digital watermark if desired. Publishers can easily stipulate that content not only be digitally watermarked but that distributors must check the validity of the watermarks by performing digital signature-checks with keys that lack any other functionality. The system can extend to simple authentication of text in other embodiments.

30 Before such a market is economically feasible, there are other methods for deploying key-based watermarking coupled with transfer functions to partially scramble the content to be distributed without performing full public key encryption, i.e., a key pair is not necessarily generated, simply, a predetermined key's function is created to re-map the data of the content file in a lossless process.

Moreover, the scrambling performed by the present invention may be more dependent on the file in question. Dissimilarly, encryption is not specific to any particular media but is performed on data. The file format remains unchanged, rendering the file useable by any conventional viewer/player, but the signal quality can be intentionally degraded in the absence of the proper player and key. Public-key encryption seeks to completely obscure the sensitive "plaintext" to prevent comparisons with the "ciphertext" to determine a user's private keys. Centralized encryption only differs in the utilization of a single key for both encryption and decryption making the key even more highly vulnerable to attacks to defeat the encryption process. With the present invention, a highly sought after photograph may be hazy to the viewer using any number of commonly available, nonproprietary software or hardware, without the authorized key. Similarly, a commercially valuable song may sound poor.

The benefit of some form of cryptography is not lost in the present invention. In fact, some piracy can be deterred when the target signal may be known but is clearly being protected through scrambling. What is not anticipated by known techniques, is an ala carte method to change various aspects of file formatting to enable various "scrambled states" for content to be subsequently distributed. An image may lack all red pixels or may not have any of the most significant bits activated. An audio sample can similarly be scrambled to render it less-than-commercially viable.

The present invention also provides improvements over known network-based methods, such as those used for the streaming of media data over the Internet. By manipulating file formats, the broadcast media, which has been altered to "fit" within electronic distribution parameters, such as bandwidth availability and error correction considerations; can be more effectively utilized to restrict the subsequent use of the content while in transit as well as real-time viewing or playing.

The mask set providing the transfer function can be read on a per-use basis by issuing an authorized or authenticating "key" for descrambling the signal that is apparent to a viewer or a player or possessor of the authenticating key. The mask set can be read on a per-computer basis by issuing the authorized key that is

more generalized for the computer that receives the broadcast signals. Metering and subscription models become viable advantages over known digital watermark systems which assist in designating the ownership of a copy of digitized media content, but do not prevent or restrict the copying or manipulation of the sampled signal in question. For broadcast or streamed media, this is especially the case. Message authentication is also possible, though not guaranteeing the same security as an encrypted file as with general crypto systems.

The present invention thus benefits from the proprietary player model without relying on proprietary players. No new players will be necessary and existing multimedia file formats can be altered to exact a measure of security which is further increased when coupled with digital watermarks. As with most consumer markets for media content, predominant file formats exist, de facto, and corresponding formats for computers likewise exist. For a commercial compact disc quality audio recording, or 16 bit 44.1 kHz, corresponding file formats include: Audio Interchange File Format (AIFF), Microsoft WAV, Sound Designer II, Sun's .au, Apple's Quicktime, etc. For still image media, formats are similarly abundant: TIFF, PICT, JPEG, GIF, etc. Requiring the use of additional proprietary players, and their complementary file formats, for limited benefits in security is wasteful. Moreover, almost all computers today are multimedia-capable, and this is increasingly so with the popularity of Intel's MMX chip architecture and the PowerPC line of microchips. Because file formatting is fundamental in the playback of the underlying data, the predetermined key can act both as a map, for information to be encoded as watermark data regarding ownership, and a descrambler of the file that has been distributed. Limitations will only exist in how large the key must be retrofitted for a given application, but any manipulation of file format information is not likely to exceed the size of data required versus that for an entire proprietary player.

As with previous disclosures by the inventor on digital watermarking techniques, the present invention may be implemented with a variety of cryptographic protocols to increase both confidence and security in the underlying system. A predetermined key is described as a set of masks. These masks may include primary, convolution and message delimiter mask. In previous disclosures,

the functionality of these masks is defined solely for mapping. The present invention includes a mask set which is also controlled by the distributing party of a copy of a given media signal. This mask set is a transfer function which is limited only by the parameters of the file format in question. To increase the uniqueness or security of each key used to scramble a given media file copy, a secure one way hash function can be used subsequent to transfer properties that are initiated to prevent the forging of a particular key. Public and private keys may be used as key pairs to further increase the unlikeliness that a key may be compromised.

These same cryptographic protocols can be combined with the embodiments of the present invention in administering streamed content that requires authorized keys to correctly display or play the streamed content in an unscrambled manner. As with digital watermarking, symmetric or asymmetric public key pairs may be used in a variety of implementations. Additionally, the need for certification authorities to maintain authentic key-pairs becomes a consideration for greater security beyond symmetric key implementations. The cryptographic protocols makes possible, as well, a message of text to be authenticated by a message authenticating function in a general computing device that is able to ensure secure message exchanges between authorizing parties.

Although various embodiments are specifically illustrated and described herein, it will be appreciated that modifications and variations of the present invention are covered by the above teachings and within the purview of the appended claims without departing from the spirit and intended scope of the invention.

What is claimed is:

1. A method for copy protection of digital information, the digital information including a digital sample and format information, comprising the steps of:
- 5 of:
- identifying a portion of the format information to be encoded;
- generating encoded format information from the identified portion of the format information; and
- generating encoded digital information, including the digital sample and the encoded format information.
- 10
2. The method of claim 1, further comprising the step of requiring a predetermined key to decode the encoded format information.
3. The method of claim 2, wherein the digital sample and format information are configured to be used with a digital player, and wherein information output from the digital player will have a degraded quality unless the encoded format information is decoded with the predetermined key.
- 15
4. The method of claim 3, wherein the information output from the digital player represents a still image, audio or video.
5. The method of claim 3, wherein the information output represents text data to be authenticated.
- 20
6. A method for protecting a digital signal, the digital signal including digital samples in a file format having an inherent granularity, comprising the step of:
- creating a predetermined key comprised of a transfer function-based mask set to manipulate data at the inherent granularity of the file format of the underlying digitized samples.
- 25
7. The method of claim 6, wherein the digital signal represents a continuous analog waveform.
8. The method of claim 6, wherein the predetermined key comprises a plurality of mask sets.
- 30
9. The method of claim 6, wherein the digital signal is a message to be authenticated.

10. The method of claim 6, wherein the mask set is ciphered by a key pair comprising a public key and a private key.

11. The method of claim 6, further comprising the step of:

5 using a digital watermarking technique to encode information that identifies ownership, use, or other information about the digital signal, into the digital signal.

12. The method of claim 6, wherein the digital signal represents a still image, audio or video.

13. The method of claim 6, further comprising the steps of:

10 selecting the mask set, including one or more masks having random or pseudo-random series of bits; and

validating the mask set at the start of the transfer function-based mask set.

14. The method of claim 13, wherein said step of validating comprises the step of:

15 comparing a hash value computed at the start of the transfer function-based mask set with a determined transfer function of the hash value.

15. The method of claim 6, further comprising the steps of:

selecting the mask set, including one or more masks having random or pseudo-random series of bits; and

20 authenticating the mask set by comparing a hash value computed at the start of the transfer function-based mask set with a determined transfer function of the hash value.

16. The method of claim 13, wherein said step of validating comprises the step of:

25 comparing a digital signature at the start of the transfer function-based mask set with a determined transfer function of the digital signature.

17. The method of claim 6, further comprising the steps of:

selecting the mask set, including one or more masks having random or pseudo-random series of bits; and

30 authenticating the mask set by comparing a digital signature at the start of the transfer function-based mask set with a determined transfer function of the digital signature.

18. The method of claim 13, further comprising the step of:
using a digital watermarking technique to embed information that identifies
ownership, use, or other information about the digital signal, into the digital signal;
and

5 wherein said step of validating is dependent on validation of the embedded
information.

19. The method of claim 6, further comprising the step of:
computing a secure one way hash function of carrier signal data in the digital
signal, wherein the hash function is insensitive to changes introduced into the carrier
10 signal for the purpose of carrying the transfer function-based mask set.

20. A method for protecting a digital signal, the digital signal including
digital samples in a file format having an inherent granularity, comprising the steps
of:

15 creating a predetermined key comprised of a transfer function-based mask
set that can manipulate data at the inherent granularity of the file format of the
underlying digitized samples;

 authenticating the predetermined key containing the correct transfer
function-based mask set during playback of the data; and

 metering the playback of the data to monitor content.

20 21. The method of claim 20, wherein the predetermined key is authenticated
to authenticate message information.

22. A method to prepare for the scrambling of a sample stream of data,
comprising the steps of:

25 generating a plurality of mask sets to be used for encoding, including a
random primary mask, a random convolution mask and a random start of message
delimiter;

 obtaining a transfer function to be implemented;

 generating a message bit stream to be encoded;

30 loading the message bit stream, a stega-cipher map truth table, the primary
mask, the convolution mask and the start of message delimiter into memory;

 initializing the state of a primary mask index, a convolution mask index, and
a message bit index; and

setting a message size equal to the total number of bits in the message bit stream.

23. A method to prepare for the encoding of stega-cipher information into a sample stream of data, comprising the steps of:

- 5 generating a mask set to be used for encoding, the set including a random primary mask, a random convolution mask, and a random start of message delimiter; obtaining a message to be encoded; compressing and encrypting the message if desired; generating a message bit stream to be encoded;
- 10 loading the message bit stream, a stega-cipher map truth table, the primary mask, the convolution mask and the start of message delimiter into memory; initializing the state of a primary mask index, a convolution mask index, and a message bit index; and
- setting the message size equal to the total number of bits in the message bit stream.
- 15

24. The method of claim 23 wherein the sample stream of data has a plurality of windows, further comprising the steps of:

- calculating over which windows in the sample stream the message will be encoded;
- 20 computing a secure one way hash function of the information in the calculated windows, the hash function generating hash values insensitive to changes in the samples induced by a stega-cipher; and
- encoding the computed hash values in an encoded stream of data.

25. The method of claim 13, wherein said step of selecting comprises the steps of:

- collecting a series of random bits derived from keyboard latency intervals in random typing;
- processing the initial series of random bits through an MD5 algorithm;
- using the results of the MD5 processing to seed a triple-DES encryption
- 30 loop;

cycling through the triple-DES encryption loop, extracting the least significant bit of each result after each cycle; and

concatenating the triple-DES output bits into the random series of bits.

26. A method for copy protection of digital information, the digital
5 information including a digital sample and format information, comprising the steps of:

a identifying a portion of the digital sample to be encoded;

generating an encoded digital sample from the identified portion of the
digital sample; and

10 generating encoded digital information, including the encoded digital sample and the format information.

27. The method of claim 26, further comprising the step of requiring a predetermined key to decode the encoded digital sample.

28. The method of claim 27, wherein the digital sample and format
15 information are configured to be used with a digital player, and wherein information output from the digital player will have a degraded quality unless the encoded digital sample is decoded with the predetermined key.

29. The method of claim 27, wherein information output will have non
20 authentic message data unless the encoded digital sample is decoded with the predetermined key.

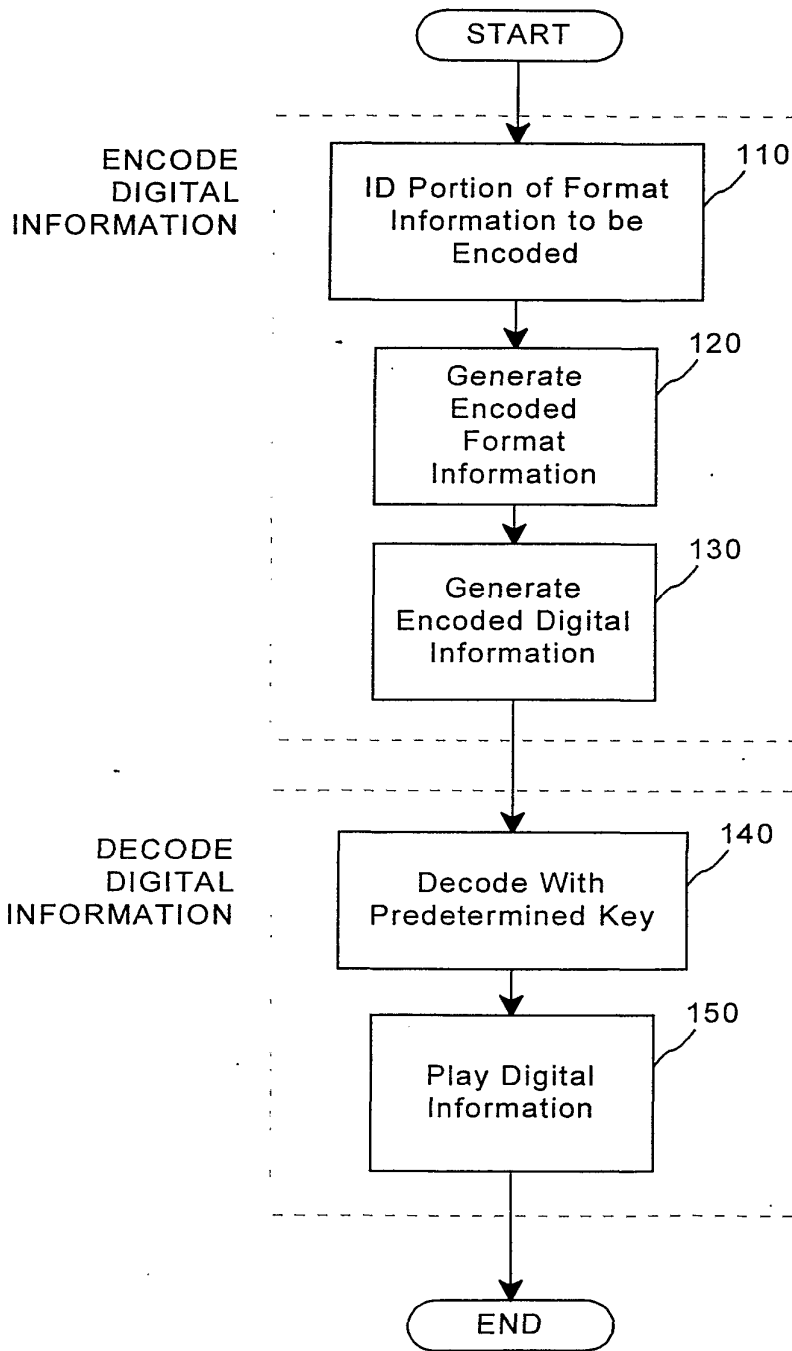

FIG. 1

INTERNATIONAL SEARCH REPORT

International Application No
PCT/US 00/18411

A. CLASSIFICATION OF SUBJECT MATTER IPC 7 G11B20/00 G06F1/00		
According to International Patent Classification (IPC) or to both national classification and IPC		
B. FIELDS SEARCHED		
Minimum documentation searched (classification system followed by classification symbols) IPC 7 G11B G06F H04N		
Documentation searched other than minimum documentation to the extent that such documents are included in the fields searched		
Electronic data base consulted during the international search (name of data base and, where practical, search terms used) EPO-Internal, WPI Data, PAJ		
C. DOCUMENTS CONSIDERED TO BE RELEVANT		
Category *	Citation of document, with indication, where appropriate, of the relevant passages	Relevant to claim No.
X	NL 1 005 523 C (EINDHOVEN TECH HOCHSCHULE) 15 September 1998 (1998-09-15) abstract; figure 4 page 1, line 35 -page 3, line 9 page 9, line 21 -page 10, line 5	1, 2, 26-29
X	WO 97 44736 A (APPLE COMPUTER) 27 November 1997 (1997-11-27) abstract; figure 4 page 2, line 35 -page 3, line 27 page 9, line 10 -page 11, line 28	1, 2
Y	---	3, 4
	--- -/--	
<input checked="" type="checkbox"/> Further documents are listed in the continuation of box C.		
<input checked="" type="checkbox"/> Patent family members are listed in annex.		
Special categories of cited documents :		
A document defining the general state of the art which is not considered to be of particular relevance *I* earlier document but published on or after the international filing date *L* document which may throw doubts on priority claim(s) or which is cited to establish the publication date of another citation or other special reason (as specified) *O* document referring to an oral disclosure, use, exhibition or other means *P* document published prior to the international filing date but later than the priority date claimed		*T* later document published after the international filing date or priority date and not in conflict with the application but cited to understand the principle or theory underlying the invention *X* document of particular relevance; the claimed invention cannot be considered novel or cannot be considered to involve an inventive step when the document is taken alone *Y* document of particular relevance; the claimed invention cannot be considered to involve an inventive step when the document is combined with one or more other such documents, such combination being obvious to a person skilled in the art. *&* document member of the same patent family
Date of the actual completion of the international search 20 July 2001		Date of mailing of the international search report 30. 07. 2001
Name and mailing address of the ISA European Patent Office, P.B. 5818 Patentlaan 2 NL - 2280 HV Rijswijk Tel. (+31-70) 340-2040, Tx. 31 651 epo nl, Fax: (+31-70) 340-3016		Authorized officer Sigolo, A

INTERNATIONAL SEARCH REPORT

International Application No
PCT/US 00/18411

C.(Continuation) DOCUMENTS CONSIDERED TO BE RELEVANT		
Category °	Citation of document, with indication, where appropriate, of the relevant passages	Relevant to claim No.
X	US 5 687 236 A (MOSKOWITZ SCOTT A ET AL) 11 November 1997 (1997-11-11) cited in the application column 5, line 1 -column 6, line 37 column 7, line 54 -column 10, line 11 column 11, line 31 -column 12, line 10 column 15, line 42 -column 16, line 32	6-12, 19-21
A	-----	22,23
A	US 5 974 141 A (SAITO MAKOTO) 26 October 1999 (1999-10-26) abstract; figures 4A-4G column 8, line 24 - line 67	5,26
X	WO 99 52271 A (MOSKOWITZ SCOTT A) 14 October 1999 (1999-10-14) abstract page 11, line 15 -page 13, line 13	6,7,10
Y	EP 0 649 261 A (CANON KK) 19 April 1995 (1995-04-19) page 3, line 53 -page 4, line 5 page 7, line 18 - line 23	3,4
A	WO 99 63443 A (DATAMARK TECHNOLOGIES PTE LTD; HO ANTHONY TUNG SHUEN (SG); TAM SIU) 9 December 1999 (1999-12-09) page 2, line 10 -page 5, line 16	6-8,11, 12

INTERNATIONAL SEARCH REPORT

International application No.
PCT/US 00/18411

Box I Observations where certain claims were found unsearchable (Continuation of item 1 of first sheet)

This International Search Report has not been established in respect of certain claims under Article 17(2)(a) for the following reasons:

- 1. Claims Nos.:
because they relate to subject matter not required to be searched by this Authority, namely:

- 2. Claims Nos.:
because they relate to parts of the International Application that do not comply with the prescribed requirements to such an extent that no meaningful international Search can be carried out, specifically:

- 3. Claims Nos.:
because they are dependent claims and are not drafted in accordance with the second and third sentences of Rule 6.4(a).

Box II Observations where unity of invention is lacking (Continuation of item 2 of first sheet)

This International Searching Authority found multiple inventions in this international application, as follows:

see additional sheet

- 1. As all required additional search fees were timely paid by the applicant, this International Search Report covers all searchable claims.

- 2. As all searchable claims could be searched without effort justifying an additional fee, this Authority did not invite payment of any additional fee.

- 3. As only some of the required additional search fees were timely paid by the applicant, this International Search Report covers only those claims for which fees were paid, specifically claims Nos.:

- 4. No required additional search fees were timely paid by the applicant. Consequently, this International Search Report is restricted to the invention first mentioned in the claims; it is covered by claims Nos.:

Remark on Protest

- The additional search fees were accompanied by the applicant's protest.
- No protest accompanied the payment of additional search fees.

FURTHER INFORMATION CONTINUED FROM PCT/ISA/ 210

This International Searching Authority found multiple (groups of) inventions in this international application, as follows:

1. Claims: 1-5,26-29

Protecting the distribution of digital data to be used with a digital player characterized by encrypting format information and allowing low quality play back in case of lack of decrypting key.

2. Claims: 6-25

Digital signature encrypting technique combining transfer functions with predetermined key creation.

INTERNATIONAL SEARCH REPORT

Information on patent family members

International Application No
PCT/US 00/18411

Patent document cited in search report	Publication date	Patent family member(s)	Publication date
NL 1005523 C	15-09-1998	NONE	
WO 9744736 A	27-11-1997	AU 3206397 A	09-12-1997
US 5687236 A	11-11-1997	US 5613004 A EP 0872073 A WO 9642151 A	18-03-1997 21-10-1998 27-12-1996
US 5974141 A	26-10-1999	US 6076077 A US 6002772 A US 6097818 A	13-06-2000 14-12-1999 01-08-2000
WO 9952271 A	14-10-1999	US 6205249 B EP 1068720 A	20-03-2001 17-01-2001
EP 0649261 A	19-04-1995	JP 7115638 A US 5933499 A	02-05-1995 03-08-1999
WO 9963443 A	09-12-1999	AU 7683398 A EP 1103026 A	20-12-1999 30-05-2001

RADIOHEAD

CDP 7243 5 84543 2 1

Capitol[®]

215

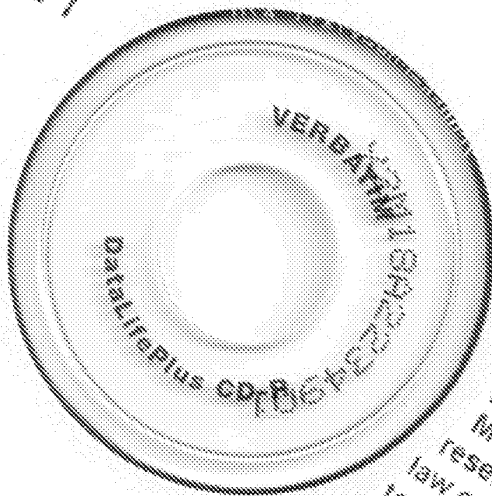

This record has been marked with a specific identification code in order to trace any unauthorized use thereof, including usage on the Internet and other digital replications. The EMI Music Group hereby reserves all of its rights at law or in equity with respect to this record and all materials embodied thereon.

"Hail To The Thief"

ADVANCE COPY - INTERNAL USE ONLY - DO NOT DUPLICATE

INTERNATIONAL SEARCH REPORT

International Application No
PCT/US 00/18411

A. CLASSIFICATION OF SUBJECT MATTER
IPC 7 G11B20/00 G06F1/00

According to International Patent Classification (IPC) or to both national classification and IPC

B. FIELDS SEARCHED

Minimum documentation searched (classification system followed by classification symbols)
IPC 7 G11B G06F H04N

Documentation searched other than minimum documentation to the extent that such documents are included in the fields searched

Electronic data base consulted during the international search (name of data base and, where practical, search terms used)
EPO-Internal, WPI Data, PAJ

C. DOCUMENTS CONSIDERED TO BE RELEVANT

Category *	Citation of document, with indication, where appropriate, of the relevant passages	Relevant to claim No.
X	NL 1 005 523 C (EINDHOVEN TECH HOCHSCHULE) 15 September 1998 (1998-09-15) abstract; figure 4 page 1, line 35 -page 3, line 9 page 9, line 21 -page 10, line 5	1,2, 26-29
X	WO 97 44736 A (APPLE COMPUTER) 27 November 1997 (1997-11-27) abstract; figure 4 page 2, line 35 -page 3, line 27 page 9, line 10 -page 11, line 28	1,2
Y	---	3,4
	-/-	

Further documents are listed in the continuation of box C.

Patent family members are listed in annex.

* Special categories of cited documents :

- *A* document defining the general state of the art which is not considered to be of particular relevance
- *I* earlier document but published on or after the international filing date
- *L* document which may throw doubts on priority claim(s) or which is cited to establish the publication date of another citation or other special reason (as specified)
- *O* document referring to an oral disclosure, use, exhibition or other means
- *P* document published prior to the international filing date but later than the priority date claimed

- *T* later document published after the international filing date or priority date and not in conflict with the application but cited to understand the principle or theory underlying the invention
- *X* document of particular relevance; the claimed invention cannot be considered novel or cannot be considered to involve an inventive step when the document is taken alone
- *Y* document of particular relevance; the claimed invention cannot be considered to involve an inventive step when the document is combined with one or more other such documents, such combination being obvious to a person skilled in the art.
- *&* document member of the same patent family

Date of the actual completion of the international search

20 July 2001

Date of mailing of the international search report

30. 07. 2001

Name and mailing address of the ISA

European Patent Office, P.B. 5818 Patentlaan 2
NL - 2280 HV Rijswijk
Tel. (+31-70) 340-2040, Tx. 31 651 epo nl,
Fac. (+31-70) 340-3016

Authorized officer

Sigolo, A

INTERNATIONAL SEARCH REPORT

International Application No
PCT/US 00/18411

C.(Continuation) DOCUMENTS CONSIDERED TO BE RELEVANT		
Category *	Citation of document, with indication, where appropriate, of the relevant passages	Relevant to claim No.
X	US 5 687 236 A (MOSKOWITZ SCOTT A ET AL) 11 November 1997 (1997-11-11) cited in the application column 5, line 1 -column 6, line 37 column 7, line 54 -column 10, line 11 column 11, line 31 -column 12, line 10 column 15, line 42 -column 16, line 32	6-12, 19-21
A	-----	22, 23
A	US 5 974 141 A (SAITO MAKOTO) 26 October 1999 (1999-10-26) abstract; figures 4A-4G column 8, line 24 - line 67	5, 26
X	WO 99 52271 A (MOSKOWITZ SCOTT A) 14 October 1999 (1999-10-14) abstract page 11, line 15 -page 13, line 13	6, 7, 10
Y	EP 0 649 261 A (CANON KK) 19 April 1995 (1995-04-19) page 3, line 53 -page 4, line 5 page 7, line 18 - line 23	3, 4
A	WO 99 63443 A (DATAMARK TECHNOLOGIES PTE LTD; HO ANTHONY TUNG SHUEN (SG); TAM SIU) 9 December 1999 (1999-12-09) page 2, line 10 -page 5, line 16	6-8, 11, 12

INTERNATIONAL SEARCH REPORT

International application No.
PCT/US 00/18411

Box I Observations where certain claims were found unsearchable (Continuation of item 1 of first sheet)

This International Search Report has not been established in respect of certain claims under Article 17(2)(a) for the following reasons:

1. Claims Nos.:
because they relate to subject matter not required to be searched by this Authority, namely:

2. Claims Nos.:
because they relate to parts of the International Application that do not comply with the prescribed requirements to such an extent that no meaningful International Search can be carried out, specifically:

3. Claims Nos.:
because they are dependent claims and are not drafted in accordance with the second and third sentences of Rule 6.4(a).

Box II Observations where unity of invention is lacking (Continuation of item 2 of first sheet)

This International Searching Authority found multiple inventions in this international application, as follows:

see additional sheet

1. As all required additional search fees were timely paid by the applicant, this International Search Report covers all searchable claims.

2. As all searchable claims could be searched without effort justifying an additional fee, this Authority did not invite payment of any additional fee.

3. As only some of the required additional search fees were timely paid by the applicant, this International Search Report covers only those claims for which fees were paid, specifically claims Nos.:

4. No required additional search fees were timely paid by the applicant. Consequently, this International Search Report is restricted to the invention first mentioned in the claims; it is covered by claims Nos.:

Remark on Protest

- The additional search fees were accompanied by the applicant's protest.
- No protest accompanied the payment of additional search fees.

FURTHER INFORMATION CONTINUED FROM PCT/ISA/ 210

This International Searching Authority found multiple (groups of) inventions in this international application, as follows:

1. Claims: 1-5,26-29

Protecting the distribution of digital data to be used with a digital player characterized by encrypting format information and allowing low quality play back in case of lack of decrypting key.

2. Claims: 6-25

Digital signature encrypting technique combining transfer functions with predetermined key creation.

INTERNATIONAL SEARCH REPORT

Information on patent family members

International Application No

PCT/US 00/18411

Patent document cited in search report	Publication date	Patent family member(s)	Publication date
NL 1005523 C	15-09-1998	NONE	
WO 9744736 A	27-11-1997	AU 3206397 A	09-12-1997
US 5687236 A	11-11-1997	US 5613004 A EP 0872073 A WO 9642151 A	18-03-1997 21-10-1998 27-12-1996
US 5974141 A	26-10-1999	US 6076077 A US 6002772 A US 6097818 A	13-06-2000 14-12-1999 01-08-2000
WO 9952271 A	14-10-1999	US 6205249 B EP 1068720 A	20-03-2001 17-01-2001
EP 0649261 A	19-04-1995	JP 7115638 A US 5933499 A	02-05-1995 03-08-1999
WO 9963443 A	09-12-1999	AU 7683398 A EP 1103026 A	20-12-1999 30-05-2001

INTERNATIONAL SEARCH REPORT

International Application No
PCT/US 00/33126

A. CLASSIFICATION OF SUBJECT MATTER IPC 7 G06F17/60		
According to International Patent Classification (IPC) or to both national classification and IPC		
B. FIELDS SEARCHED Minimum documentation searched (classification system followed by classification symbols) IPC 7 G06F		
Documentation searched other than minimum documentation to the extent that such documents are included in the fields searched		
Electronic data base consulted during the international search (name of data base and, where practical, search terms used)		
C. DOCUMENTS CONSIDERED TO BE RELEVANT		
Category *	Citation of document, with indication, where appropriate, of the relevant passages	Relevant to claim No.
X	US 5 903 721 A (SIXTUS TIMOTHY) 11 May 1999 (1999-05-11) abstract column 3, line 26 -column 5, line 31	1-19
X	US 5 790 677 A (SPELMAN JEFFREY F ET AL) 4 August 1998 (1998-08-04) abstract column 2, line 6 -column 4, line 39	1-19
X	WO 96 29795 A (MICALI SILVIO) 26 September 1996 (1996-09-26) abstract page 5, line 27 -page 8, line 6	1-19
-/--		
<input checked="" type="checkbox"/> Further documents are listed in the continuation of box C. <input checked="" type="checkbox"/> Patent family members are listed in annex.		
* Special categories of cited documents :		
A document defining the general state of the art which is not considered to be of particular relevance *E* earlier document but published on or after the international filing date *L* document which may throw doubts on priority claim(s) or which is cited to establish the publication date of another citation or other special reason (as specified) *O* document referring to an oral disclosure, use, exhibition or other means *P* document published prior to the international filing date but later than the priority date claimed		*T* later document published after the international filing date or priority date and not in conflict with the application but cited to understand the principle or theory underlying the invention *X* document of particular relevance; the claimed invention cannot be considered novel or cannot be considered to involve an inventive step when the document is taken alone *Y* document of particular relevance; the claimed invention cannot be considered to involve an inventive step when the document is combined with one or more other such documents, such combination being obvious to a person skilled in the art. *A* document member of the same patent family
Date of the actual completion of the international search 20 March 2001		Date of mailing of the international search report 04.04.01
Name and mailing address of the ISA European Patent Office, P.B. 5818 Patentaan 2 NL - 2280 HV Rijswijk Tel. (+31-70) 340-2040, Tx. 31 651 epo nl, Fax (+31-70) 340-3016		Authorized officer Corcoran, P

INTERNATIONAL SEARCH REPORT

In onal Application No
PCT/US 00/33126

C.(Continuation) DOCUMENTS CONSIDERED TO BE RELEVANT		
Category *	Citation of document, with indication, where appropriate, of the relevant passages	Relevant to claim No.
X	WO 97 24833 A (NICALI SILVIO) 10 July 1997 (1997-07-10) abstract page 2, line 12 -page 5, line 8	1-19
A	US 5 539 735 A (MOSKOWITZ SCOTT A) 23 July 1996 (1996-07-23) abstract column 1, line 60 -column 4, line 29	1-19
A	SIRBU M ET AL: "NETBILL: AN INTERNET COMMERCE SYSTEM OPTIMIZED FOR NETWORK DELIVERED SERVICES" DIGEST OF PAPERS OF THE COMPUTER SOCIETY COMPUTER CONFERENCE (SPRING) COMPCON,US,LOS ALAMITOS, IEEE COMP. SOC. PRESS, vol. CONF. 40, 5 March 1995 (1995-03-05), pages 20-25, XP000577034 ISBN: 0-7803-2657-1 The whole document	1-19
A	SCHUNTER M ET AL: "A status report on the SEMPER framework for secure electronic commerce" COMPUTER NETWORKS AND ISDN SYSTEMS,NL,NORTH HOLLAND PUBLISHING. AMSTERDAM, vol. 30, no. 16-18, 30 September 1998 (1998-09-30), pages 1501-1510, XP004138681 ISSN: 0169-7552 2. Model for electronic commerce 3. The SEMPER framework	1-19
A	KONRAD K ET AL: "Trust and electronic commerce-more than a technical problem" PROCEEDINGS OF THE 18TH IEEE SYMPOSIUM ON RELIABLE DISTRIBUTED SYSTEMS, PROCEEDINGS 18TH IEEE SYMPOSIUM ON RELIABLE DISTRIBUTED SYSTEMS, LAUSANNE, SWITZERLAND, 19-22 OCT. 1999, pages 360-365, XP002162270 1999, Los Alamitos, CA, USA, IEEE Comput. Soc, USA ISBN: 0-7695-0290-3 3. Trust, Security and Electronic Commerce 4. Technology and Institutions	1-19

-/--

INTERNATIONAL SEARCH REPORT

International Application No
PCT/US 00/33126

C.(Continuation) DOCUMENTS CONSIDERED TO BE RELEVANT		
Category °	Citation of document, with indication, where appropriate, of the relevant passages	Relevant to claim No.
A	<p>KINI A ET AL: "Trust in electronic commerce: definition and theoretical considerations" PROCEEDINGS OF THE THIRTY-FIRST HAWAII INTERNATIONAL CONFERENCE ON SYSTEM SCIENCES (CAT. NO.98TB100216), PROCEEDINGS OF THE THIRTY-FIRST HAWAII INTERNATIONAL CONFERENCE ON SYSTEM SCIENCES, KOHALA COAST, HI, USA, 6-9 JAN. 1998, pages 51-61, XP002162271 1998, Los Alamitos, CA, USA, IEEE Comput. Soc, USA ISBN: 0-8186-8255-8 1.3 The Significance of Trust in Electronic Commerce,</p>	1-19
A	<p>STEINAUER D D ET AL: "Trust and traceability in electronic commerce" STANDARD VIEW, SEPT. 1997, ACM, USA, vol. 5, no. 3, pages 118-124, XP002162272 ISSN: 1067-9936 The whole document</p>	1-19
A	<p>US 5 687 236 A (MOSKOWITZ SCOTT A ET AL) 11 November 1997 (1997-11-11) abstract</p>	8,9
A	<p>US 5 745 569 A (MOSKOWITZ SCOTT A ET AL) 28 April 1998 (1998-04-28) abstract</p>	8,9

INTERNATIONAL SEARCH REPORT

Information on patent family members

International Application No
PCT/US 00/33126

Patent document cited in search report	Publication date	Patent family member(s)	Publication date
US 5903721 A	11-05-1999	AU 6549498 A	29-09-1998
		DE 1008022 T	25-01-2001
		EP 1008022 A	14-06-2000
		ES 2150892 T	16-12-2000
		NO 994428 A	09-11-1999
		WO 9840809 A	17-09-1998
		US 5790677 A	04-08-1998
WO 9629795 A	26-09-1996	WO 9806198 A	12-02-1998
		CA 2215908 A	26-09-1996
		EP 0815671 A	07-01-1998
		US 5553145 A	03-09-1996
		US 5629982 A	13-05-1997
		US 5666420 A	09-09-1997
		US 6137884 A	24-10-2000
		US 6141750 A	31-10-2000
		EP 0917781 A	26-05-1999
		JP 2000515649 T	21-11-2000
WO 9724833 A	10-07-1997	US 5615269 A	25-03-1997
		AU 1951497 A	28-07-1997
US 5539735 A	23-07-1996	US 5428606 A	27-06-1995
		WO 9701892 A	16-01-1997
US 5687236 A	11-11-1997	US 5613004 A	18-03-1997
		EP 0872073 A	21-10-1998
		WO 9642151 A	27-12-1996
US 5745569 A	28-04-1998	AU 1829497 A	11-08-1997
		WO 9726732 A	24-07-1997

INTERNATIONAL SEARCH REPORT

International application No.
PCT/US 00/33126

Box I Observations where certain claims were found unsearchable (Continuation of Item 1 of first sheet)

This International Search Report has not been established in respect of certain claims under Article 17(2)(a) for the following reasons:

1. Claims Nos.:
because they relate to subject matter not required to be searched by this Authority, namely:

2. Claims Nos.: 20-186
because they relate to parts of the International Application that do not comply with the prescribed requirements to such an extent that no meaningful International Search can be carried out, specifically:
see FURTHER INFORMATION sheet PCT/ISA/210

3. Claims Nos.:
because they are dependent claims and are not drafted in accordance with the second and third sentences of Rule 6.4(a).

Box II Observations where unity of invention is lacking (Continuation of Item 2 of first sheet)

This International Searching Authority found multiple inventions in this international application, as follows:

1. As all required additional search fees were timely paid by the applicant, this International Search Report covers all searchable claims.

2. As all searchable claims could be searched without effort justifying an additional fee, this Authority did not invite payment of any additional fee.

3. As only some of the required additional search fees were timely paid by the applicant, this International Search Report covers only those claims for which fees were paid, specifically claims Nos.:

4. No required additional search fees were timely paid by the applicant. Consequently, this International Search Report is restricted to the invention first mentioned in the claims; it is covered by claims Nos.:

Remark on Protest

- The additional search fees were accompanied by the applicant's protest.
 No protest accompanied the payment of additional search fees.

INTERNATIONAL SEARCH REPORT

International Application No. PCT/US 00 83126

FURTHER INFORMATION CONTINUED FROM PCT/ISA/ 210

Continuation of Box I.2

Claims Nos.: 20-186

In view of the large number and also the wording of the claims presently on file, which render it difficult, if not impossible, to determine the matter for which protection is sought, the present application fails to comply with the clarity and conciseness requirements of Article 6 PCT (see also Rule 6.1(a) PCT) to such an extent that a meaningful search is impossible.

Moreover, the proliferation of independent claims and the broad manner in which these have been worded make it impossible to determine which parts of the claims may be said to define subject-matter for which protection might legitimately be sought (Article 6 PCT). For these reasons, a meaningful search over the whole breadth of the claim(s) is impossible.

Consequently, the search has been restricted to the subject matter recited in claims 1-19.

The applicant's attention is drawn to the fact that claims, or parts of claims, relating to inventions in respect of which no international search report has been established need not be the subject of an international preliminary examination (Rule 66.1(e) PCT). The applicant is advised that the EPO policy when acting as an International Preliminary Examining Authority is normally not to carry out a preliminary examination on matter which has not been searched. This is the case irrespective of whether or not the claims are amended following receipt of the search report or during any Chapter II procedure.

INTERNATIONAL SEARCH REPORT

International application No.
PCT/US00/21189

A. CLASSIFICATION OF SUBJECT MATTER
 IPC(7) :H04L 9/32; H04N 7/167
 US CL :713/176; 705/51, 52, 57; 380/203, 231
 According to International Patent Classification (IPC) or to both national classification and IPC

B. FIELDS SEARCHED
 Minimum documentation searched (classification system followed by classification symbols)
 U.S. : 713/153; 705/51, 52, 57; 380/203, 231

Documentation searched other than minimum documentation to the extent that such documents are included in the fields searched

Electronic data base consulted during the international search (name of data base and, where practicable, search terms used)
 APS EAST/BRS text search terms: watermark, audio, copy protect, distribution

C. DOCUMENTS CONSIDERED TO BE RELEVANT

Category*	Citation of document, with indication, where appropriate, of the relevant passages	Relevant to claim No.
Y	US 5,636,292 A (RHOADS) 03 JUNE 1997, col. 33, line 42-col. 34, line 8.	4, 6-15 and 17-29
Y	US 5,629,980 A (STEFIK et al) 13 MAY 1997, col. 26, line 37-col. 27, line 26.	1-30
Y, P	US 5,943,422 A (VAN WIE et al) 24 AUGUST 1999, col. 6, line 53-62 and col. 10, line 18-56.	4, 6-15 and 17-29.
Y	US 5,636,276 A (BRUGGER) 03 JUNE 1997, col. 5, line 53-col. 6, line 8.	1-30.
Y	US 5,341,429 A (STRINGER et al) 23 AUGUST 1994, col. 4, lines 1-22.	30

Further documents are listed in the continuation of Box C. See patent family annex.

* Special categories of cited documents:	*T* later document published after the international filing date or priority date and not in conflict with the application but cited to understand the principle or theory underlying the invention
A document defining the general state of the art which is not considered to be of particular relevance	*X* document of particular relevance; the claimed invention cannot be considered novel or cannot be considered to involve an inventive step when the document is taken alone
E earlier document published on or after the international filing date	*Y* document of particular relevance; the claimed invention cannot be considered to involve an inventive step when the document is combined with one or more other such documents, such combination being obvious to a person skilled in the art
L document which may throw doubts on priority claim(s) or which is cited to establish the publication date of another citation or other special reason (as specified)	*&* document member of the same patent family
O document referring to an oral disclosure, use, exhibition or other means	
P document published prior to the international filing date but later than the priority date claimed	

Date of the actual completion of the international search: 26 JANUARY 2001
 Date of mailing of the international search report: 23 MAR 2001

Name and mailing address of the ISA/US Commissioner of Patents and Trademarks
 Box PCT
 Washington, D.C. 20231
 Facsimile No. (703) 305-3230

Authorized officer: GILBERTO BARRÓN (with signature)
 Telephone No. (703) 305-3900

Electronic Patent Application Fee Transmittal

Application Number:	11895388			
Filing Date:	24-Aug-2007			
Title of Invention:	Data protection method and device			
First Named Inventor/Applicant Name:	Scott A. Moskowitz			
Filer:	Richard A. Neifeld			
Attorney Docket Number:	SCOT0014-4			
Filed as Large Entity				
Utility under 35 USC 111(a) Filing Fees				
Description	Fee Code	Quantity	Amount	Sub-Total in USD(\$)
Basic Filing:				
Pages:				
Claims:				
Miscellaneous-Filing:				
Petition:				
Patent-Appeals-and-Interference:				
Post-Allowance-and-Post-Issuance:				
Extension-of-Time:				

Description	Fee Code	Quantity	Amount	Sub-Total in USD(\$)
Miscellaneous:				
Submission- Information Disclosure Stmt	1806	1	180	180
Total in USD (\$)				180

Electronic Acknowledgement Receipt

EFS ID:	8875555
Application Number:	11895388
International Application Number:	
Confirmation Number:	2103
Title of Invention:	Data protection method and device
First Named Inventor/Applicant Name:	Scott A. Moskowitz
Customer Number:	31518
Filer:	Richard A. Neifeld
Filer Authorized By:	
Attorney Docket Number:	SCOT0014-4
Receipt Date:	19-NOV-2010
Filing Date:	24-AUG-2007
Time Stamp:	13:27:21
Application Type:	Utility under 35 USC 111(a)

Payment information:

Submitted with Payment	yes
Payment Type	Credit Card
Payment was successfully received in RAM	\$ 180
RAM confirmation Number	11755
Deposit Account	502106
Authorized User	NEIFELD,RICHARD ALAN

The Director of the USPTO is hereby authorized to charge indicated fees and credit any overpayment as follows:

Charge any Additional Fees required under 37 C.F.R. Section 1.17 (Patent application and reexamination processing fees)

File Listing:					
Document Number	Document Description	File Name	File Size(Bytes)/ Message Digest	Multi Part /.zip	Pages (if appl.)
1	Information Disclosure Statement (IDS) Filed (SB/08)	IDS_SCOT00014-4_11-19-2010. pdf	289537 61b15c2b6e845d09736b2ef5117823eb379 d857c	no	61
Warnings:					
Information:					
This is not an USPTO supplied IDS fillable form					
2	Foreign Reference	F03_EP0581317_Powell.pdf	991420 75189109658ea20e753cf2cc8a3f044fb016 4b41	no	14
Warnings:					
Information:					
3	Foreign Reference	F16_9726733_Cooperman.pdf	1238906 7bac8d26a91a0abd5438c40f74d4a7c65cd 6cd99	no	31
Warnings:					
Information:					
4	Foreign Reference	F17_WO98002864_Moskowitz. pdf	1987330 8554170a0ffc1015686010727c7e64ef0b9 d906	no	42
Warnings:					
Information:					
5	Foreign Reference	F18_WO0057643_Moskowitz. pdf	1306998 901ac580d647adb60b2486c003820e1 d69214	no	32
Warnings:					
Information:					
6	Foreign Reference	F19_WO9642151A2_Cooperma n.pdf	1996433 feb8a0d7d7694a53a6c010d7e88efa90a528 d395	no	51
Warnings:					
Information:					
7	Foreign Reference	F20_EP0872073_Moskowitz. pdf	168773 785b52e59b5e40d24aa532339c0f01557c 0b323	no	20
Warnings:					
Information:					
8	Foreign Reference	F24_97001892_Moskowitz.pdf	2214466 3f9f73b54db98695870e60aaeb577ea2ed 7262	no	48
Warnings:					
Information:					

9	Foreign Reference	F25_WO9726732A1_Moskowitz.pdf	925925 c6e3b73c95206f8b99a2e78b76a7646f94a926ba	no	22
Warnings:					
Information:					
10	Foreign Reference	F29_WO023385A1_Moskowitz.pdf	1155616 8c63f407023fe535801a6c4c4516448e23946034	no	24
Warnings:					
Information:					
11	Foreign Reference	L99_radiohead.pdf	161424 5eb0b91f91d42d56e8f72e4de6fe7d3b6d3c599a	no	1
Warnings:					
Information:					
12	NPL Documents	L101_AppAsFiled_60169274.pdf	4713018 d46f7ca11ab7ebd788e3a5b7500f184b4a12dc6e	no	109
Warnings:					
Information:					
13	NPL Documents	L104_AppAsFiled_60234199.pdf	1020520 7b83ac66d1f82aa12579af879f26c71147ca533	no	22
Warnings:					
Information:					
14	NPL Documents	L105_AppAsFiled_09671739.pdf	2123598 a569c23676a6c85984c88ec553547f524585d0b5	no	45
Warnings:					
Information:					
15	NPL Documents	L115_Tirkel.pdf	516739 20597036ed76876fc1297908c5c19b873af7904	no	6
Warnings:					
Information:					
16	NPL Documents	L165_ISR_PCTUS0018411.pdf	158813 947426f1b4e9ce1a5d8b5a15c36b5f2015807f8d	no	5
Warnings:					
Information:					
17	NPL Documents	L166_ISR_PCTUS0033126.pdf	237580 21a4fb068c3a0e6744e08ec64937331401c504f	no	6
Warnings:					
Information:					

18	NPL Documents	L167_ISR_PCTUS0021189.pdf	52841 4f60d9eb2425aa056f8f03f1301d698e4c76f9cd	no	1
Warnings:					
Information:					
19	NPL Documents	L176_Oasis.pdf	112690 81ca38c8a4655a9a4017cae154e00c4fc08576c8	no	1
Warnings:					
Information:					
20	NPL Documents	L201_AppAsFiled_60222023.pdf	1037383 bc64421923a7bffc2aab35038a7715f27f14f503	no	26
Warnings:					
Information:					
21	NPL Documents	L204_Howe.pdf	46179 93534120df67cfdcf6fec36fd2ace20f2ee66c73	no	1
Warnings:					
Information:					
22	NPL Documents	L205_ComputerSupportGroup.pdf	670522 0cb171f1029c31c3e17599e770391a0cee215a03	no	22
Warnings:					
Information:					
23	NPL Documents	L206_QuinStreetInc.pdf	516868 214d1126f78da12c9b79005f44958a33a4df137	no	3
Warnings:					
Information:					
24	NPL Documents	L207_Graham.pdf	829429 e2cab2814763ee4191126d6b583b93a0e89a1f65	no	53
Warnings:					
Information:					
25	NPL Documents	L208_Farkex.pdf	131101 0ab624785449d89231ad4276244729031c9b3bef	no	2
Warnings:					
Information:					
26	NPL Documents	L209_Horowitz.pdf	720077 40fafa6906b6186d4f22873080988ecf9f86db7	no	2
Warnings:					
Information:					

27	NPL Documents	L210_Jimmy.pdf	80935 cc8ce39428ff4495209590aa6a843aa5ea0b433	no	2
Warnings:					
Information:					
28	NPL Documents	L211-212_Aerosmith.pdf	555209 2f89426db1251b06fb5868e5bf688ad07e3f1667	no	6
Warnings:					
Information:					
29	NPL Documents	L203_Morimoto.pdf	3646930 33e715e742346f9038e34e503fa239287dacca7c	no	79
Warnings:					
Information:					
30	Fee Worksheet (PTO-875)	fee-info.pdf	30328 a85239f6028e630a788920c63d164157a7c6ba71	no	2
Warnings:					
Information:					
Total Files Size (in bytes):				29637588	
<p>This Acknowledgement Receipt evidences receipt on the noted date by the USPTO of the indicated documents, characterized by the applicant, and including page counts, where applicable. It serves as evidence of receipt similar to a Post Card, as described in MPEP 503.</p> <p><u>New Applications Under 35 U.S.C. 111</u> If a new application is being filed and the application includes the necessary components for a filing date (see 37 CFR 1.53(b)-(d) and MPEP 506), a Filing Receipt (37 CFR 1.54) will be issued in due course and the date shown on this Acknowledgement Receipt will establish the filing date of the application.</p> <p><u>National Stage of an International Application under 35 U.S.C. 371</u> If a timely submission to enter the national stage of an international application is compliant with the conditions of 35 U.S.C. 371 and other applicable requirements a Form PCT/DO/EO/903 indicating acceptance of the application as a national stage submission under 35 U.S.C. 371 will be issued in addition to the Filing Receipt, in due course.</p> <p><u>New International Application Filed with the USPTO as a Receiving Office</u> If a new international application is being filed and the international application includes the necessary components for an international filing date (see PCT Article 11 and MPEP 1810), a Notification of the International Application Number and of the International Filing Date (Form PCT/RO/105) will be issued in due course, subject to prescriptions concerning national security, and the date shown on this Acknowledgement Receipt will establish the international filing date of the application.</p>					



UNITED STATES PATENT AND TRADEMARK OFFICE

UNITED STATES DEPARTMENT OF COMMERCE
United States Patent and Trademark Office
Address: COMMISSIONER FOR PATENTS
P.O. Box 1450
Alexandria, Virginia 22313-1450
www.uspto.gov

Table with 5 columns: APPLICATION NO., FILING DATE, FIRST NAMED INVENTOR, ATTORNEY DOCKET NO., CONFIRMATION NO.
11/895,388 08/24/2007 Scott A. Moskowitz SCOT0014-4 2103

31518 7590 11/26/2010
NEIFELD IP LAW, PC
4813-B EISENHOWER AVENUE
ALEXANDRIA, VA 22304

Table with 1 column: EXAMINER

OKEKE, IZUNNA

Table with 2 columns: ART UNIT, PAPER NUMBER

2432

Table with 2 columns: NOTIFICATION DATE, DELIVERY MODE

11/26/2010

ELECTRONIC

Please find below and/or attached an Office communication concerning this application or proceeding.

The time period for reply, if any, is set in the attached communication.

Notice of the Office communication was sent electronically on above-indicated "Notification Date" to the following e-mail address(es):

general@neifeld.com
rneifeld@neifeld.com
rhahl@neifeld.com

Office Action Summary	Application No.	Applicant(s)	
	11/895,388	MOSKOWITZ, SCOTT A.	
	Examiner	Art Unit	
	IZUNNA OKEKE	2432	

-- The MAILING DATE of this communication appears on the cover sheet with the correspondence address --
Period for Reply

A SHORTENED STATUTORY PERIOD FOR REPLY IS SET TO EXPIRE 3 MONTH(S) OR THIRTY (30) DAYS, WHICHEVER IS LONGER, FROM THE MAILING DATE OF THIS COMMUNICATION.

- Extensions of time may be available under the provisions of 37 CFR 1.136(a). In no event, however, may a reply be timely filed after SIX (6) MONTHS from the mailing date of this communication.
- If NO period for reply is specified above, the maximum statutory period will apply and will expire SIX (6) MONTHS from the mailing date of this communication.
- Failure to reply within the set or extended period for reply will, by statute, cause the application to become ABANDONED (35 U.S.C. § 133). Any reply received by the Office later than three months after the mailing date of this communication, even if timely filed, may reduce any earned patent term adjustment. See 37 CFR 1.704(b).

Status

- 1) Responsive to communication(s) filed on 03 September 2010.
- 2a) This action is **FINAL**. 2b) This action is non-final.
- 3) Since this application is in condition for allowance except for formal matters, prosecution as to the merits is closed in accordance with the practice under *Ex parte Quayle*, 1935 C.D. 11, 453 O.G. 213.

Disposition of Claims

- 4) Claim(s) 32-45 and 52-64 is/are pending in the application.
4a) Of the above claim(s) _____ is/are withdrawn from consideration.
- 5) Claim(s) _____ is/are allowed.
- 6) Claim(s) 32-45 and 52-64 is/are rejected.
- 7) Claim(s) _____ is/are objected to.
- 8) Claim(s) _____ are subject to restriction and/or election requirement.

Application Papers

- 9) The specification is objected to by the Examiner.
- 10) The drawing(s) filed on _____ is/are: a) accepted or b) objected to by the Examiner.
Applicant may not request that any objection to the drawing(s) be held in abeyance. See 37 CFR 1.85(a).
Replacement drawing sheet(s) including the correction is required if the drawing(s) is objected to. See 37 CFR 1.121(d).
- 11) The oath or declaration is objected to by the Examiner. Note the attached Office Action or form PTO-152.

Priority under 35 U.S.C. § 119

- 12) Acknowledgment is made of a claim for foreign priority under 35 U.S.C. § 119(a)-(d) or (f).
a) All b) Some * c) None of:
1. Certified copies of the priority documents have been received.
2. Certified copies of the priority documents have been received in Application No. _____.
3. Copies of the certified copies of the priority documents have been received in this National Stage application from the International Bureau (PCT Rule 17.2(a)).

* See the attached detailed Office action for a list of the certified copies not received.

Attachment(s)

- 1) Notice of References Cited (PTO-892)
- 2) Notice of Draftsperson's Patent Drawing Review (PTO-948)
- 3) Information Disclosure Statement(s) (PTO/SB/08)
Paper No(s)/Mail Date _____.
- 4) Interview Summary (PTO-413)
Paper No(s)/Mail Date _____.
- 5) Notice of Informal Patent Application
- 6) Other: _____.

DETAILED ACTION

Response to Arguments

1. Applicant's arguments with respect to claims 32-45 and 52-61 have been considered but are moot in view of the new ground(s) of rejection.
2. With respect to Item 1 of applicant's argument and remarks, examiner clarifies that claims 58 and 59 were part of group II in the initial restriction requirement but were omitted from the group due to typographical error. However, examiner addressed claims 58 and 59 (as part of the elected group) in the OA of 04/05/2010 and to that effect, claims 58 and 59 are still pending in the case. In this amendment, applicant indicates claims 58 and 59 as "new". This is incorrect. Claims 58 and 59 should either be indicated as "cancelled" or "amended" because they are not new claims in the case.

Double Patenting

1. The nonstatutory double patenting rejection is based on a judicially created doctrine grounded in public policy (a policy reflected in the statute) so as to prevent the unjustified or improper timewise extension of the "right to exclude" granted by a patent and to prevent possible harassment by multiple assignees. A nonstatutory obviousness-type double patenting rejection is appropriate where the conflicting claims are not identical, but at least one examined application claim is not patentably distinct from the reference claim(s) because the examined application claim is either anticipated by, or would have been obvious over, the reference claim(s). See, e.g., *In re Berg*, 140 F.3d 1428, 46 USPQ2d 1226 (Fed. Cir. 1998); *In re Goodman*, 11 F.3d 1046, 29 USPQ2d 2010 (Fed. Cir. 1993); *In re Longi*, 759 F.2d 887, 225 USPQ 645 (Fed. Cir. 1985); *In re Van Ornum*, 686 F.2d 937, 214 USPQ 761 (CCPA 1982); *In re*

Vogel, 422 F.2d 438, 164 USPQ 619 (CCPA 1970); and *In re Thorington*, 418 F.2d 528, 163 USPQ 644 (CCPA 1969).

A timely filed terminal disclaimer in compliance with 37 CFR 1.321(c) or 1.321(d) may be used to overcome an actual or provisional rejection based on a nonstatutory double patenting ground provided the conflicting application or patent either is shown to be commonly owned with this application, or claims an invention made as a result of activities undertaken within the scope of a joint research agreement.

Effective January 1, 1994, a registered attorney or agent of record may sign a terminal disclaimer. A terminal disclaimer signed by the assignee must fully comply with 37 CFR 3.73(b).

2. Claim 32-45 and 52-64 are rejected on the ground of nonstatutory obviousness-type double patenting as being unpatentable over claims 1-20 of U.S. Patent No. 5,745,569. Although the conflicting claims are not identical, they are not patentably distinct from each other because both inventions are directed to a method of copy protecting a software or digital data wherein a license is watermarked into the software and a license key derived from license information is used to decode/access the watermark to enable authorized use of the software.

Claim Objections

1. Claims 32 and 41 objected to because of the following informalities: Claim 32 recites in part; “thereby resulting in a first license code encoded watermarked software, wherein said first license code encoded watermarked software”. The last part of the limitation implies that the license code encoded the watermarked software. This recitation is inconsistent with the disclosure in the specification. Applicant is asked to review the claim with respect to the

limitations presented. Claim 41 recites “wherein said watermark encodes therein information”. It is not clear what/which information is being referred to. The term “information” is too broad and any watermark has “information” encoded therein. Appropriate correction is required.

Claim Rejections - 35 USC § 112

1. The following is a quotation of the first paragraph of 35 U.S.C. 112:

The specification shall contain a written description of the invention, and of the manner and process of making and using it, in such full, clear, concise, and exact terms as to enable any person skilled in the art to which it pertains, or with which it is most nearly connected, to make and use the same and shall set forth the best mode contemplated by the inventor of carrying out his invention.

2. Claims 62-64 are rejected under 35 U.S.C. 112, first paragraph, as failing to comply with the written description requirement. The claim(s) contains subject matter which was not described in the specification in such a way as to reasonably convey to one skilled in the relevant art that the inventor(s), at the time the application was filed, had possession of the claimed invention.

Claims 62 recites in part “wherein said software code defines software code interrelationships between code resources” and “to form a first license key encoded software code in which at least one of said software code interrelationship are encoded”. The specification provides no support for this limitation as it fails to teach or mention “software code interrelationships”, how the software code defines interrelationships between code resources and how it is encoded to form a first license key encoded software code. Applicant is asked to identify the section of the specification that provides support for claim 62.

Claim 63 and dependent claim 64 recites in part “encoding, by said computer using at least a first license key and an encoding algorithm, said software code, to form a second license key encoded software code; wherein said first license key encoded software code is not identical

to said second license key encoded software code”. There is also no disclosure that supports this limitation in the specification. There is no disclosure of using a “second license key” to encode a software code to form a “second license key encoded software code” wherein a first license key encoded software code is not identical to a second license key encoded software code. Applicant is also asked to point out the section of the specification that clearly provides support for claims 63 and 64.

Claim Rejections - 35 USC § 102

(e) the invention was described in (1) an application for patent, published under section 122(b), by another filed in the United States before the invention by the applicant for patent or (2) a patent granted on an application for patent by another filed in the United States before the invention by the applicant for patent, except that an international application filed under the treaty defined in section 351(a) shall have the effects for purposes of this subsection of an application filed in the United States only if the international application designated the United States and was published under Article 21(2) of such treaty in the English language.

3. Claims 32-45 and 52-61 are rejected under 35 U.S.C. 102(e) as being anticipated by Houser et al. (US-5606609).

a. Referring to claim 32, 40, 45, 52 and 59:

Regarding claim 32, 40, 45, 52 and 59, Houser teaches a computer-based method for modifying software, comprising: receiving, in a computer having a processor and memory, software, wherein said software provides a specified functionality (Col 7, Line 15-28... electronic document software); embedding a watermark into said software, using said computer, said watermark encoding at least one first license code, thereby resulting in a first license code encoded watermarked software, wherein said first license code encoded watermarked software (Col 7, Line 30-60... embedding a watermark into the electronic document wherein the watermark comprises a license security code thereby resulting a licensed security code encoded watermarked document).

a. Referring to claim 33 and 57:

Regarding claim 33 and 57, Houser teaches the process of claim 32, wherein said embedding increases the complexity of code analysis and/or tampering with said first license code encoded watermarked software (Col 7, Line 45-60... embedding the security code as a watermark increases the complexity of tampering with the security code or software).

a. Referring to claim 34 and 54:

Regarding claim 34 and 54, Houser teaches the process of claim 32, wherein said first license code encoded watermarked software is configured to query a user for personalization information during its installation (Col 9, Line 20-25... personalization information during installation).

a. Referring to claim 35, 36 and 53:

Regarding claim 35, 36 and 53, Houser teaches the process of claim 32, wherein [[the]] said watermark is accessible with a key (Col 9, Line 37-60... the embedded security code is decoded using a key).

a. Referring to claim 37 and 44:

Regarding claim 37 and 44, Houser teaches the process according to claim 34, wherein said first license code encoded watermarked software is configured to determine said key from said personalization information (Col 9, Line 37-60... key can be determined from password).

a. Referring to claim 38:

Regarding claim 38, Houser teaches the process according to claim 32, wherein the step of embedding the software with a watermark is performed during execution of the software (Col 7, Line 29-43... embedding the watermark after creation of the document).

a. Referring to claim 39:

Regarding claim 39, Houser teaches the process according to claim 32, wherein said embedding modifies the structure of said software (Col 7, Line 45-64... embedding the security watermark modifies the structure of the original document).

a. Referring to claim 41 and 55:

Regarding claim 41 and 55, Houser teaches the article of manufacture of claim 40, wherein said watermark encodes therein information (Col 7, Line 45-64... security watermark encodes information).

a. Referring to claim 42 and 56:

Regarding claim 42 and 56, Houser teaches the article of manufacture of claim 40, wherein the watermark affects functionality of the watermarked software (Col 9, Line 20-36... security watermark affects functionality of the watermarked document such as verifying user, etc.).

a. Referring to claim 43:

Regarding claim 43, Houser teaches the article of manufacture of claim 41, wherein said instructions comprise decode instructions for said computer system to use said information to generate a decode key for decoding said software (Col 9, Line 37-60... decryption key generated from password and used for decrypting the document code).

a. Referring to claim 58:

Regarding claim 58, Houser teaches a method for licensed software use, the method comprising: loading a software product on a computer, said computer comprising a processor, memory, an input, and an output, so that said computer is programmed to execute said software product; said software product outputting a prompt for input of license information; and said

software product using license information entered via said input in response to said prompt in a routine designed to decode a first license code encoded in said software (See the rejection in claim 32 and 34).

a. Referring to claim 60:

Regarding claim 60, Houser teaches the method of claim 59 wherein, when installed on a computer system, said first license key encoded software code will provide said specified underlying functionality only after receipt of said first license key (Col 9, Line 20-35 and Line 60-67... after receipt of the password, access to the document is provided).

a. Referring to claim 61:

Regarding claim 61, Houser teaches a method for encoding software code using a computer having a processor and memory, comprising:
storing a software code in said memory; wherein said software code comprises a first code resource and provides a specified underlying functionality when installed on a computer system;
and modifying, by said computer, using a first license key and an encoding algorithm, said software code, to form a modified software code; and wherein said modifying comprises encoding said first code resource to form an encoded first code resource; wherein said modified software code comprises said encoded first code resource, and a decode resource for decoding said encoded first code resource; wherein said decode resource is configured to decode said encoded first code resource upon receipt of said first license key (See the rejection in claims 32, 34, 35, 42 and 43).

Conclusion

4. Applicant's amendment necessitated the new ground(s) of rejection presented in this Office action. Accordingly, **THIS ACTION IS MADE FINAL**. See MPEP § 706.07(a). Applicant is reminded of the extension of time policy as set forth in 37 CFR 1.136(a).

A shortened statutory period for reply to this final action is set to expire THREE MONTHS from the mailing date of this action. In the event a first reply is filed within TWO MONTHS of the mailing date of this final action and the advisory action is not mailed until after the end of the THREE-MONTH shortened statutory period, then the shortened statutory period will expire on the date the advisory action is mailed, and any extension fee pursuant to 37 CFR 1.136(a) will be calculated from the mailing date of the advisory action. In no event, however, will the statutory period for reply expire later than SIX MONTHS from the date of this final action.

Any inquiry concerning this communication or earlier communications from the examiner should be directed to IZUNNA OKEKE whose telephone number is (571)270-3854. The examiner can normally be reached on 9:00am - 5:00pm.

If attempts to reach the examiner by telephone are unsuccessful, the examiner's supervisor, Gilberto Barron can be reached on (571) 272-3799. The fax phone number for the organization where this application or proceeding is assigned is 571-273-8300.

Information regarding the status of an application may be obtained from the Patent Application Information Retrieval (PAIR) system. Status information for published applications may be obtained from either Private PAIR or Public PAIR. Status information for unpublished applications is available through Private PAIR only. For more information about the PAIR system, see <http://pair-direct.uspto.gov>. Should you have questions on access to the Private PAIR system, contact the Electronic Business Center (EBC) at 866-217-9197 (toll-free). If you would like assistance from a USPTO Customer Service Representative or access to the automated information system, call 800-786-9199 (IN USA OR CANADA) or 571-272-1000.

/IZUNNA OKEKE/
Examiner, Art Unit 2432

/Jung Kim/
Primary Examiner, AU 2432

Notice of References Cited	Application/Control No. 11/895,388	Applicant(s)/Patent Under Reexamination MOSKOWITZ, SCOTT A.	
	Examiner IZUNNA OKEKE	Art Unit 2432	Page 1 of 1

U.S. PATENT DOCUMENTS

*		Document Number Country Code-Number-Kind Code	Date MM-YYYY	Name	Classification
*	A	US-5,606,609	02-1997	Houser et al.	713/179
	B	US-			
	C	US-			
	D	US-			
	E	US-			
	F	US-			
	G	US-			
	H	US-			
	I	US-			
	J	US-			
	K	US-			
	L	US-			
	M	US-			

FOREIGN PATENT DOCUMENTS

*		Document Number Country Code-Number-Kind Code	Date MM-YYYY	Country	Name	Classification
	N					
	O					
	P					
	Q					
	R					
	S					
	T					

NON-PATENT DOCUMENTS

*		Include as applicable: Author, Title Date, Publisher, Edition or Volume, Pertinent Pages)
	U	
	V	
	W	
	X	

*A copy of this reference is not being furnished with this Office action. (See MPEP § 707.05(a).)
Dates in MM-YYYY format are publication dates. Classifications may be US or foreign.

<i>Index of Claims</i> 	Application/Control No. 11895388	Applicant(s)/Patent Under Reexamination MOSKOWITZ, SCOTT A.
	Examiner IZUNNA OKEKE	Art Unit 2432

✓	Rejected	-	Cancelled	N	Non-Elected	A	Appeal
=	Allowed	÷	Restricted	I	Interference	O	Objected

Claims renumbered in the same order as presented by applicant
 CPA
 T.D.
 R.1.47

CLAIM		DATE							
Final	Original	03/22/2010	11/11/2010						
	32	✓	✓						
	33	✓	✓						
	34	✓	✓						
	35	✓	✓						
	36	✓	✓						
	37	✓	✓						
	38	✓	✓						
	39	✓	✓						
	40	✓	✓						
	41	✓	✓						
	42	✓	✓						
	43	✓	✓						
	44	✓	✓						
	45	✓	✓						
	52	✓	✓						
	53	✓	✓						
	54	✓	✓						
	55	✓	✓						
	56	✓	✓						
	57	✓	✓						
	58	✓	✓						
	59	✓	✓						
	60		✓						
	61		✓						
	62		✓						
	63		✓						
	64		✓						

Search Notes 	Application/Control No. 11895388	Applicant(s)/Patent Under Reexamination MOSKOWITZ, SCOTT A.
	Examiner IZUNNA OKEKE	Art Unit 2432

SEARCHED			
Class	Subclass	Date	Examiner

SEARCH NOTES		
Search Notes	Date	Examiner
Text Search (See History)	11/11/2010	IO
Keyword + Classification Search (See History)	11/11/2010	IO
Search (713/165, 713/176, 713/161, 380/201, 380/228, 380/229) (See History)	11/11/2010	IO
NPL Search	11/11/2010	IO

INTERFERENCE SEARCH			
Class	Subclass	Date	Examiner

--	--

EAST Search History

EAST Search History (Prior Art)

Ref #	Hits	Search Query	DBs	Default Operator	Plurals	Time Stamp
S3	38	((reduced or low\$3) near3 (quality)) same ((digital near3 content) or audio or video) same (watermark or steganograph\$3 or (copy near3 protect \$3))	US-PGPUB; USPAT; USOCR; FPRS; EPO; JPO; DERWENT	AND	ON	2009/11/03 09:18
S4	209	((reduced or low\$3) near3 (quality)) same ((digital near3 content) or audio or video) and (watermark or steganograph\$3 or (copy near3 protect \$3)) and (key same (encrypt\$3 or scanmbl\$3))	US-PGPUB; USPAT; USOCR; FPRS; EPO; JPO; DERWENT	AND	ON	2009/11/03 09:41
S5	91	((play\$3 or reproduc \$3 or copy\$3) same (reduced or low\$3) near3 (quality)) same ((digital near3 content) or audio or video) and (watermark or steganograph\$3 or (copy near3 protect \$3)) and (key same (encrypt\$3 or scanmbl\$3))	US-PGPUB; USPAT; USOCR; FPRS; EPO; JPO; DERWENT	AND	ON	2009/11/03 09:52
S6	277	((reduced or low\$3 or degraded) near3 (quality)) same ((digital near3 content) or audio or video) and ((endode or decode) same key)	US-PGPUB; USPAT; USOCR; FPRS; EPO; JPO; DERWENT	AND	ON	2009/11/03 10:55

S7	2270	380/201	US-PGPUB; USPAT; USOCR; FPRS; EPO; JPO; DERWENT	AND	ON	2009/11/03 10:58
S8	1206	380/210	US-PGPUB; USPAT; USOCR; FPRS; EPO; JPO; DERWENT	AND	ON	2009/11/03 10:59
S9	453	380/217	US-PGPUB; USPAT; USOCR; FPRS; EPO; JPO; DERWENT	AND	ON	2009/11/03 10:59
S10	77	380/218	US-PGPUB; USPAT; USOCR; FPRS; EPO; JPO; DERWENT	AND	ON	2009/11/03 10:59
S11	105	380/236	US-PGPUB; USPAT; USOCR; FPRS; EPO; JPO; DERWENT	AND	ON	2009/11/03 10:59
S12	8	S6 and S7	US-PGPUB; USPAT; USOCR; FPRS; EPO; JPO; DERWENT	AND	ON	2009/11/03 11:00
S13	13	S6 and S8	US-PGPUB; USPAT; USOCR; FPRS; EPO; JPO; DERWENT	AND	ON	2009/11/03 11:00
S14	5	S6 and S9	US-PGPUB; USPAT; USOCR; FPRS; EPO; JPO; DERWENT	AND	ON	2009/11/03 11:00
S16	2	S6 and S11	US-PGPUB; USPAT; USOCR; FPRS; EPO; JPO; DERWENT	AND	ON	2009/11/03 11:00
S17	75	scott near2 moskowitz.inv.	US-PGPUB; USPAT; USOCR; FPRS; EPO; JPO; DERWENT	AND	ON	2009/11/03 11:47

S18	60	(unauthorized near3 (user or device or player)) and ((digital near3 content) or audio or video) and ((encode or decode) same key) and ((reduced or low or degraded) near3 quality)	US-PGPUB; USPAT; USOCR; FPRS; EPO; JPO; DERWENT	AND	ON	2009/11/03 12:47
S19	415	((reduced or low\$3 or degraded) near3 (quality)) same ((digital near3 content) or audio or video) and ((encode or decode) same key)	US-PGPUB; USPAT; USOCR; FPRS; EPO; JPO; DERWENT	AND	ON	2009/11/03 12:47
S20	166	((degrad\$3 or reduc\$3) near3 (quality)) same ((digital near3 content) or video or audio)) and (unauthorized near3 (user or player or device))	US-PGPUB; USPAT; USOCR; FPRS; EPO; JPO; DERWENT	AND	ON	2009/11/03 13:06
S21	8860	((degrad\$3 or reduc\$3) near3 (quality)) same ((digital near3 content) or video or audio))	US-PGPUB; USPAT; USOCR; FPRS; EPO; JPO; DERWENT	AND	ON	2009/11/03 13:17
S22	79	S7 and S21	US-PGPUB; USPAT; USOCR; FPRS; EPO; JPO; DERWENT	AND	ON	2009/11/03 13:18
S23	3490	((degrad\$3 or reduc\$3) near3 (quality)) near3 ((digital near3 content) or video or audio))	US-PGPUB; USPAT; USOCR; FPRS; EPO; JPO; DERWENT	AND	ON	2009/11/03 13:18
S24	32	S7 and S23	US-PGPUB; USPAT; USOCR; FPRS; EPO; JPO; DERWENT	AND	ON	2009/11/03 13:18

S25	73	380/206	US-PGPUB; USPAT; USOCR; FPRS; EPO; JPO; DERWENT	AND	ON	2009/11/03 13:21
S26	39	380/226	US-PGPUB; USPAT; USOCR; FPRS; EPO; JPO; DERWENT	AND	ON	2009/11/03 13:21
S27	387	380/232	US-PGPUB; USPAT; USOCR; FPRS; EPO; JPO; DERWENT	AND	ON	2009/11/03 13:21
S31	1	"11895388"	US-PGPUB; USPAT; USOCR; FPRS; EPO; JPO; DERWENT	AND	ON	2010/03/18 07:46
S37	492	(software with (copy near3 protect \$3)) and (key same authoriz\$5)	US-PGPUB; USPAT; USOCR; FPRS; EPO; JPO; DERWENT	AND	ON	2010/03/22 09:10
S38	84	(software with (copy near3 protect \$3)) and (key same authoriz\$5) and (digital near3 watermark)	US-PGPUB; USPAT; USOCR; FPRS; EPO; JPO; DERWENT	AND	ON	2010/03/22 09:10
S39	2149	(software near3 protect\$3) and (key same authoriz\$5)	US-PGPUB; USPAT; USOCR; FPRS; EPO; JPO; DERWENT	AND	ON	2010/03/22 09:11
S41	41	("4558176" "4644493" "4652990" "4688169" "4796220" "4866769" "5109413" "5113518" "5182770" "5199066" "5267311" "5276738" "5343524" "5402492" "5615263" "5619408" "5675645").PN. OR ("6067622").URPN.	US-PGPUB; USPAT; USOCR	AND	ON	2010/03/22 09:40

S42	2023	713/165	AND	ON	2010/03/22	20:58	US-PG/PUB; USPAT; USOCR; FPRS; EPO; JPO; DERWENT
S43	6293	713/176	AND	ON	2010/03/22	20:58	US-PG/PUB; USPAT; USOCR; FPRS; EPO; JPO; DERWENT
S44	1123	713/161	AND	ON	2010/03/22	20:58	US-PG/PUB; USPAT; USOCR; FPRS; EPO; JPO; DERWENT
S45	2403	380/201	AND	ON	2010/03/22	20:58	US-PG/PUB; USPAT; USOCR; FPRS; EPO; JPO; DERWENT
S46	365	380/228	AND	ON	2010/03/22	20:58	US-PG/PUB; USPAT; USOCR; FPRS; EPO; JPO; DERWENT
S47	268	380/229	AND	ON	2010/03/22	20:58	US-PG/PUB; USPAT; USOCR; FPRS; EPO; JPO; DERWENT
S48	492	(software with (copy near3 protect \$3)) and (key same authoriz\$5)	AND	ON	2010/03/22	20:59	US-PG/PUB; USPAT; USOCR; FPRS; EPO; JPO; DERWENT
S49	492	S48	AND	ON	2010/03/22	20:59	US-PG/PUB; USPAT; USOCR; FPRS; EPO; JPO; DERWENT
S50	22	S48 and S42	AND	ON	2010/03/22	20:59	US-PG/PUB; USPAT; USOCR; FPRS; EPO; JPO; DERWENT
S51	39	S48 and S43	AND	ON	2010/03/22	20:59	US-PG/PUB; USPAT; USOCR; FPRS; EPO; JPO; DERWENT
S52	8	S48 and S44	AND	ON	2010/03/22	20:59	US-PG/PUB; USPAT; USOCR; FPRS; EPO; JPO; DERWENT
S53	62	S48 and S45	AND	ON	2010/03/22	20:59	US-PG/PUB; USPAT; USOCR; FPRS; EPO; JPO; DERWENT

S54	12	S48 and S46	US-PGPUB; USPAT; USOCR; FPRS; EPO; JPO; DERWENT	AND	ON	2010/03/22 20:59
S55	6	S48 and S47	US-PGPUB; USPAT; USOCR; FPRS; EPO; JPO; DERWENT	AND	ON	2010/03/22 20:59
S56	2149	(software near3 protect\$3) and (key same authoriz\$5)	US-PGPUB; USPAT; USOCR; FPRS; EPO; JPO; DERWENT	AND	ON	2010/03/22 21:06
S57	2149	S56	US-PGPUB; USPAT; USOCR; FPRS; EPO; JPO; DERWENT	AND	ON	2010/03/22 21:06
S58	112	S56 and S42	US-PGPUB; USPAT; USOCR; FPRS; EPO; JPO; DERWENT	AND	ON	2010/03/22 21:06
S59	172	S56 and S43	US-PGPUB; USPAT; USOCR; FPRS; EPO; JPO; DERWENT	AND	ON	2010/03/22 21:06
S60	37	S56 and S44	US-PGPUB; USPAT; USOCR; FPRS; EPO; JPO; DERWENT	AND	ON	2010/03/22 21:06
S61	113	S56 and S45	US-PGPUB; USPAT; USOCR; FPRS; EPO; JPO; DERWENT	AND	ON	2010/03/22 21:06
S62	21	S56 and S46	US-PGPUB; USPAT; USOCR; FPRS; EPO; JPO; DERWENT	AND	ON	2010/03/22 21:06
S63	11	S56 and S47	US-PGPUB; USPAT; USOCR; FPRS; EPO; JPO; DERWENT	AND	ON	2010/03/22 21:06
S64	144	(software with (copy near3 protect \$3)) and (digital near3 watermark)	US-PGPUB; USPAT; USOCR; FPRS; EPO; JPO; DERWENT	AND	ON	2010/03/22 21:15
S66	181	(software with (copy near3 protect \$3)) and (digital same watermark)	US-PGPUB; USPAT; USOCR; FPRS; EPO; JPO; DERWENT	AND	ON	2010/03/22 21:16

S67	75	(software with (copy near3 protect \$3)) and (authenticat\$5 same watermark)	US-PGPUB; USPAT; USOCR; FPRS; EPO; JPO; DERWENT	AND	ON	2010/03/22 21:16
S68	493	(software with (copy near3 protect \$3)) and (authenticat\$5 same key)	US-PGPUB; USPAT; USOCR; FPRS; EPO; JPO; DERWENT	AND	ON	2010/03/22 21:16
S69	107	(software with (copy near3 protect \$3)) and (authoriz \$5 same watermark)	US-PGPUB; USPAT; USOCR; FPRS; EPO; JPO; DERWENT	AND	ON	2010/03/22 21:16
S70	492	(software with (copy near3 protect \$3)) and (authoriz \$5 same key)	US-PGPUB; USPAT; USOCR; FPRS; EPO; JPO; DERWENT	AND	ON	2010/03/22 21:16
S71	2054	((copy near3 protect \$3)) and (key same authoriz\$5)	US-PGPUB; USPAT; USOCR; FPRS; EPO; JPO; DERWENT	AND	ON	2010/03/22 21:17
S72	51	((copy near3 protect \$3)) and ((key same authoriz\$5) with watermark)	US-PGPUB; USPAT; USOCR; FPRS; EPO; JPO; DERWENT	AND	ON	2010/03/22 21:17
S73	130	((copy near3 protect \$3)) and ((key same authoriz\$5) same watermark)	US-PGPUB; USPAT; USOCR; FPRS; EPO; JPO; DERWENT	AND	ON	2010/03/22 21:31
S74	1434	(software with (copy near3 protect \$3))	US-PGPUB; USPAT; USOCR; FPRS; EPO; JPO; DERWENT	AND	ON	2010/03/22 21:32
S75	44	S74 and S42	US-PGPUB; USPAT; USOCR; FPRS; EPO; JPO; DERWENT	AND	ON	2010/03/22 21:32
S76	77	S74 and S43	US-PGPUB; USPAT; USOCR; FPRS; EPO; JPO; DERWENT	AND	ON	2010/03/22 21:32
S77	17	S74 and S44	US-PGPUB; USPAT; USOCR; FPRS; EPO; JPO; DERWENT	AND	ON	2010/03/22 21:32

S78	120	S74 and S45	US-PGPUB; USPAT; USOCR; FPRS; EPO; JPO; DERWENT	AND	ON	2010/03/22 21:32
S79	13	S74 and S46	US-PGPUB; USPAT; USOCR; FPRS; EPO; JPO; DERWENT	AND	ON	2010/03/22 21:32
S80	7	S74 and S47	US-PGPUB; USPAT; USOCR; FPRS; EPO; JPO; DERWENT	AND	ON	2010/03/22 21:32
S81	1770	705/57	US-PGPUB; USPAT; USOCR; FPRS; EPO; JPO; DERWENT	AND	ON	2010/03/22 21:34
S82	106	S74 and S81	US-PGPUB; USPAT; USOCR; FPRS; EPO; JPO; DERWENT	AND	ON	2010/03/22 21:34
S83	188	S71 and S81	US-PGPUB; USPAT; USOCR; FPRS; EPO; JPO; DERWENT	AND	ON	2010/03/22 21:34
S84	63	S70 and S81	US-PGPUB; USPAT; USOCR; FPRS; EPO; JPO; DERWENT	AND	ON	2010/03/22 21:34
S85	59	S68 and S81	US-PGPUB; USPAT; USOCR; FPRS; EPO; JPO; DERWENT	AND	ON	2010/03/22 21:34
S86	135	S56 and S81	US-PGPUB; USPAT; USOCR; FPRS; EPO; JPO; DERWENT	AND	ON	2010/03/22 21:34
S87	17	((watermark\$3) near3 (software)) with (license)	US-PGPUB; USPAT; USOCR; FPRS; EPO; JPO; DERWENT	AND	ON	2010/11/10 13:29
S88	2	"5748783".pn.	US-PGPUB; USPAT; USOCR; FPRS; EPO; JPO; DERWENT	AND	ON	2010/11/10 17:27

S89	286	((watermark) near (code or license or software)) and ((protect\$3 or secur\$3) near5 (software or program or application))	US-PGPUB; USPAT; USOCR; FPRS; EPO; JPO; DERWENT	AND	ON	2010/11/11 15:56
S90	972	((watermark) near5 (code or license or software)) and ((protect\$3 or secur\$3) near5 (software or program or application))	US-PGPUB; USPAT; USOCR; FPRS; EPO; JPO; DERWENT	AND	ON	2010/11/11 15:57
S91	315	((digital near2 watermark) near5 (code or license or software)) and ((protect\$3 or secur\$3) near5 (software or program or application))	US-PGPUB; USPAT; USOCR; FPRS; EPO; JPO; DERWENT	AND	ON	2010/11/11 15:57
S92	35	((digital near2 watermark) near5 (code or license or software)) same ((protect\$3 or secur\$3) near5 (software or program or application))	US-PGPUB; USPAT; USOCR; FPRS; EPO; JPO; DERWENT	AND	ON	2010/11/11 15:57
S93	65	((embed\$4 near4 watermark) near5 (code or license)) same ((protect\$3 or secur\$3) near5 (software or program or application))	US-PGPUB; USPAT; USOCR; FPRS; EPO; JPO; DERWENT	AND	ON	2010/11/11 15:58
S94	26	((embed\$4 near4 watermark) near5 (code or license)) same ((protect\$3 or secur\$3) near5 (software or program))	US-PGPUB; USPAT; USOCR; FPRS; EPO; JPO; DERWENT	AND	ON	2010/11/11 15:59
S95	25	((embed\$4 near4 watermark) near5 (code or license)) same ((protect\$3 or secur\$3) near5 (software))	US-PGPUB; USPAT; USOCR; FPRS; EPO; JPO; DERWENT	AND	ON	2010/11/11 15:59

S96	19	((embed\$4 near4 watermark) near5 (software)) same (copyright or piracy)	US-PGPUB; USPAT; USOCR; FPRS; EPO; JPO; DERWENT	AND	ON	2010/11/11 16:00
S97	327	((embed\$4 near4 watermark) near5 (software))	US-PGPUB; USPAT; USOCR; FPRS; EPO; JPO; DERWENT	AND	ON	2010/11/11 16:49
S98	246	((embed\$4 near4 watermark) near3 (software))	US-PGPUB; USPAT; USOCR; FPRS; EPO; JPO; DERWENT	AND	ON	2010/11/11 16:49
S99	9	((embed\$4 near4 watermark) near3 (software)) and (License near2 (key or code))	US-PGPUB; USPAT; USOCR; FPRS; EPO; JPO; DERWENT	AND	ON	2010/11/11 16:49
S100	36	((embed\$4 near4 watermark) near3 (software)) same (security or protection)	US-PGPUB; USPAT; USOCR; FPRS; EPO; JPO; DERWENT	AND	ON	2010/11/11 16:50

EAST Search History (Interference)

Ref #	Hits	Search Query	DBs	Default Operator	Plurals	Time Stamp
S29	5	(scott near2 moskowitz.inv.) and (degraded.clm.)	USPAT; UPAD	AND	ON	2009/11/03 11:51
S30	3	(scott near2 moskowitz.inv.) and (degraded adj quality.clm.)	USPAT; UPAD	AND	ON	2009/11/03 11:51
S35	26	(scott near2 moskowitz.inv.) and (watermark.clm.)	USPAT; UPAD	AND	ON	2010/03/22 07:17
S36	25	(scott near2 moskowitz.inv.) and (key.clm.)	USPAT; UPAD	AND	ON	2010/03/22 07:23

11/11/2010 4:51:12 PM

C:\Documents and Settings\ioeke\My Documents\EAST\Workspaces\11895388.wsp

Neifeld Docket No: SCOT0014-4

Application/Patent No: 11/895,388

USPTO CONFIRMATION NO: 2103

File/Issue Date: 8/24/2007

Inventor/title: Moskowitz/ Data protection method and device

Examiner/ArtUnit: Izunna OKEKE/2432

ENTITY STATUS: SMALL (CONVERT UPON ALLOWANCE TO LARGE)

Priority: Application No. 09/046,627 (which issued July 22, 2003, as U.S. Patent No. 6,598,162)

**37 CFR 1.7(c) FILING RECEIPT AND TRANSMITTAL LETTER WITH
AUTHORIZATION TO CHARGE DEPOSIT ACCOUNT**

1. **THE COMMISSIONER IS HEREBY AUTHORIZED TO CHARGE ANY FEES WHICH MAY BE REQUIRED, OR CREDIT ANY OVERPAYMENT, TO DEPOSIT ACCOUNT NUMBER 50-2106.**

2. **FEES (PAID HEREWITH BY EFS CREDIT CARD SUBMISSION) \$ 0**

A. CLAIMS FEES

B. OTHER FEES

3. **THE FOLLOWING DOCUMENTS ARE SUBMITTED HEREWITH:**
AMENDMENT TO SPECIFICATION
CLAIMS
REMARKS

4. **FOR INTERNAL NEIFELD IP LAW, PC USE ONLY**

acct/ck/No/date/amnt: 6/

Firm charge:

INITIALS OF PERSON WHO **ENTERED** ACCOUNTING DATA: RAN

ATTORNEY SIGNATURE (AUTHORIZING DEPOSIT ACCOUNT)

2/27/2011

/RichardNeifeld#35,299/

RICHARD NEIFELD, REG. NO. 35,299

ATTORNEY OF RECORD

Printed: February 27, 2011 (8:49pm)

Y:\Clients\SCOT Scott A Moskowitz and Wistaria Trading,

Inc\SCOT0014-4\Drafts\RemarksIRTOA_SCOT0014-4_2-26-2011.wpd

REMARKS

SPECIFICATION

The applicant submits herewith an amendment to the first paragraph of the specification. The file history of Application No. 10/602,777, filed June 25, 2003, now Patent No 7,664,263, issued February 16, 2010, indicates that the reference in that application's specification to the priority application 08/587,943 was erroneous because the application data sheet filed with the subject patent application did not contain the reference to 08/587,943. This error in claiming priority inadvertently made in the parent case of the subject application has propagated into the subject application. The specification amendment corrects the propagated error.

REMARKS IN RESPONSE TO THE 11/26/2010 FINAL OFFICE ACTION

Please note the claims have only been formally amended in response to objections; no new limitations have been added and therefore the claim amendments should be entered and this response considered in the sense that the amendment to claim 42 provides a limitation so similar to claims 42-43 dependent therefrom as to raise no new issue. Moreover, I believe that upon review, the examiner will agree that rejections and objections have been overcome by the claim amendment, terminal disclaimer, and remarks presented below. I request that the examiner telephone me if upon review there are any remaining issues that need to be resolved.

FORMAL ISSUE

OA page 2 item 2 notes that claims 58 and 59 were improperly identified as "new". In response, claims 58 and 59 are identified herein as "Previously Presented".

DOUBLE PATENTING REJECTION OVER USP 5,745,569

OA page 3 item 2 rejects claims 32-45 and 52-64 based upon claims 1-20 of USP 5,745,569. The OA reasons that claims herein are obvious over claims of USP 5,745,569 because claims of USP 5,745,569 define "a method of copy protecting a software or digital data *wherein a license is watermarked into the software* and a license key derived from license information is used to decode/access the watermark to enable authorized use of the software." OA page 5 lines 14-16.

In response, first, please note that claims of USP 5,745,569 do not define "*a license is watermarked into the software.*" In contrast, in this application: independent claim 32 recites "a license is watermarked into the software"; independent claim 52 recites "wherein said watermark encodes at least one first license code"; independent claim 58 recites "a first license code encoded in said software"; independent claim 59 recites "form a first license key encoded software code"; independent claim 61 recites "modifying, by said computer, using a first license key and an encoding algorithm, said software code, to form a modified software code"; independent claim 62 recites "encoding, by said computer using at least a first license key and an encoding algorithm, said software code, to form a first license key encoded software code "; and independent claim 63 recites "encoding, by said computer using at least a first license key and an encoding algorithm, said software code, to form a first license key encoded software code".

In response, second, please note that claims of USP 5,745,569 do not define "identifying a watermark in software". In contrast, in this application, independent claim 40 defines "using said licensing information in an algorithm to identify a watermark in said software".

For the foregoing reasons, the applicant submits that the double patenting rejection based upon claims 1-20 of USP 5,745,569 is improper and should be reversed.

CLAIM OBJECTIONS

OA page 3 item 1 objects to claims 32 and 41.

In response to the objection to claim 32, the applicant deletes the surplussage text "~~wherein said first license code encoded watermarked software~~" recitation.

In response to the objection to claim 41, the applicant notes the following paragraph in the specification:

" This invention represents a significant improvement over prior art because of the inherent difference in use of purely informational watermarks versus watermarks which contain executable object code. If the executable object code in a watermark is essential to an application which accesses the data which contains the watermark, this creates an all-or-none situation. Either the user must have the extracted watermark, or the application cannot be used, and hence the user cannot gain full access to the presentation of the information in the watermark bearing data. In order to extract a digital watermark, the user must have a key. The key, in turn, is a function of the license information for the copy of the software in question. The key is fixed prior to final assembly of the application files, and so cannot be changed at the option of the user. That, in turn, means the license information in the software copy must remain fixed, so that the correct key is available to the software. The key and the license information are, in fact, interchangeable. One is merely more readable than the other. In U.S. Pat. No. 5,613,004, the 'Steganographic Method and Device, patent', the possibility of randomization erasure attacks on digital watermarks was discussed. Simply, it is always possible to erase a digital watermark, depending on how much damage you are willing to do to the watermark-bearing content stream. The present invention has the significant advantage that you must have the watermark to be able to use the code it contains. If you erase the watermark you have lost a key piece of the functionality of the application, or even the means to access the data which bear the watermark."

Accordingly, the applicant amends claim 41 to recite "information defining an executable code providing a functionality of said software."

112, 1ST PARAGRAPH CLAIM REJECTIONS

OA page 4 item 2 rejects claims 62-64 under 112, 1st paragraph, requesting the applicant to identify support for the following recitations:

Claim 62: "software code interrelationships" and encoding to form a first license key encoded software. Claims 63 and 64: the first license key encoded software being not identical to the second license key encoded software.

In response, claim 62 reads as follows:

" 62. (Previously Presented) A method for encoding software code using a computer having a processor and memory, comprising:
storing a software code in said memory;
wherein said software code defines software code interrelationships between code resources that result in a specified underlying functionality when installed on a computer system; and
encoding, by said computer using at least a first license key and an encoding algorithm, said software code, to form a first license key encoded software code in which at least one of said software code interrelationships are encoded."

Refer to the US 20080016365 publication of this application.

The specification recites in relevant part "[0065] Once the code resources of a program are loaded into memory, they typically remain in a fixed position, unless the computer operating system finds it necessary to rearrange certain portions of memory during "system time," when the operating

system code, not application code, is running." This passage supports the claimed "storing a software code in said memory;".

The specification recites in relevant part "[0066] Under the present invention, the application contains a special code resource which knows about all the other code resources in memory." This passage supports the claimed "wherein said software code defines software code interrelationships between code resources".

The specification recites in relevant part, further in published paragraph [0066] that "During execution time, this special code resource, called a "memory scheduler," can be called periodically, or at random or pseudo random intervals, at which time it intentionally shuffles the other code resources randomly in memory, so that someone trying to analyze snapshots of memory at various intervals cannot be sure if they are looking at the same code or organization from one "break" to the next. This adds significant complexity to their job. The scheduler also randomly relocates itself when it is finished. In order to do this, the scheduler would have to first copy itself to a new location, and then specifically modify the program counter and stack frame, so that it could then jump into the new copy of the scheduler, but return to the correct calling frame. Finally, the scheduler would need to maintain a list of all memory addresses which contain the address of the scheduler, and change them to reflect its new location." This passage supports the claimed "wherein said software code defines software code interrelationships between code resources *that result in a specified underlying functionality when installed on a computer system;*"

The specification recites in relevant part that "[0056] One method of the present invention is now discussed. When code and data resources are compiled and assembled into a precursor of an executable program the next step is to use a utility application for final assembly of the executable application. The programmer marks several essential code resources in a list displayed by the utility. The utility will choose one or several essential code resources, and encode them into one or several data resources using the stegacipher process. The end result will be that these essential code resources are not stored in their own partition, but rather stored as encoded information in data resources. They are not accessible at run-time without the key." This passage supports the claimed "encoding, by said computer using at least a first license key and an encoding algorithm, said software code, to form a first license key encoded software code in which at least one of said software code interrelationships are encoded."

Accordingly, claim 62 is supported.

The following excerpts from the publication of the application disclose plural versions of a software, each encoded with a different mask and thereby resulting in non identical encoded versions of an original software.

"[0049] As with previous disclosures by the inventor on digital watermarking techniques, the present invention may be implemented with a variety of cryptographic protocols to increase both confidence and security in the underlying system. A predetermined key is described as a set of masks. These masks may include primary, convolution and message delimiter mask. In previous disclosures, the functionality of these masks is defined solely for mapping. The present invention includes a mask set which is also controlled by the distributing party of a copy of a given media signal. This mask set is a transfer function which is limited only by the parameters of the file format in question. To increase the uniqueness or security of each key used to scramble a given media file copy, a secure one way hash function can be used subsequent to transfer properties that are initiated to prevent the forging of a particular key. Public and private keys may be used as key pairs to

further increase the unlikelihood that a key may be compromised. "

and

"[0047] The mask set providing the transfer function can be read on a per-use basis by issuing an authorized or authenticating "key" for descrambling the signal that is apparent to a viewer or a player or possessor of the authenticating key. The mask set can be read on a per-computer basis by issuing the authorized key that is more generalized for the computer that receives the broadcast signals. Metering and subscription models become viable advantages over known digital watermark systems which assist in designating the ownership of a copy of digitized media content, but do not prevent or restrict the copying or manipulation of the sampled signal in question. For broadcast or streamed media, this is especially the case. Message authentication is also possible, though not guaranteeing the same security as an encrypted file as with general crypto systems. "

The foregoing excerpts therefore support claim 63's "encoding, by said computer using at least a first license key and an encoding algorithm, said software code, to form a first license key encoded software code; encoding, by said computer using at least a second license key and an encoding algorithm, said software code, to form a second license key encoded software code; wherein said first license key encoded software code is not identical to said second license key encoded software code if said first license key is not identical to said second license key." For the same reasons, the foregoing excerpts support claim 64's "wherein both said first license key encoded software code and said second license key encoded software code are capable of providing said specified underlying functionality when installed on a computer system."

102(E) REJECTIONS BASED UPON US 5606609 TO HOUSER

OA page 5 item 3 rejects claims 32-45 and 52-61 under 102(e) based upon US 5606609 to Houser. In response, the applicant traverses for the following reasons.

Claim 32 recites "embedding a watermark into said software, using said computer, said watermark encoding at least one first license code, thereby resulting in a first license code encoded watermarked software." A watermark in this art refers to information embedded into a digital signal in a way that is difficult to remove. Regarding the meaning of "software", our specification states that: "[0033] An improvement over the art is disclosed in the present invention, in that the software itself is a set of commands, compiled by software engineer, which can be configured in such a manner as to tie underlying functionality to the license or authorization of the copy in possession by the user. Without such verification, the functions sought out by the user in the form of software cease to properly work. Attempts to tamper or "patch" substitute code resources can be made highly difficult by randomizing the location of said resources in memory on an intermittent basis to resist most attacks at disabling the system."

Houser does not disclose claim 32's "embedding a watermark into said software".

First, Houser does not disclose embedding into "software". Houser col. 7 lines 19-21 clarify that an "application" generates an "electronic document". An application defines software. An electronic document defines a data file in a format readable by some software. As noted in Houser in connection with the discussion of the interrelationship of the electronic document to the embedded object, "As seen in FIG. 5, an electronic document 510 may be a text file created by any conventional application, as noted above."

The OA at page 5 item 3a corresponds Houser's data file with the claim 32's "software", which is incorrect because Houser's data file is not software, it is data. Accordingly, Houser does

not anticipate.

Second, Houser does not disclose a "watermark" being embedded. It discloses only an object being embedded at a specified location in the electronic document. The OA cites Houser 7:30-60 for disclosing a watermark. However, Houser 7:30-60 does not disclose a watermark. Houser 7:30-60 contains no details about the relationship of the data defining the embedded object to the data defining the electronic document.

Houser Fig. 5, and 11:52 to 12:39 provide Houser's description of embodiments of the embedded object in the electronic document. Each of these embodiments relies upon the location of the object being predetermined and definite. In this regard, Houser notes that "FIG. 5 illustrates an electronic document having security objects embedded therein in accordance with the present invention." In describing the embedded object, Houser further notes that "In general, the security object may be embedded at any location within or appended to the electronic document. Different applications used to create the electronic document 510 may handle OLE security objects in different ways. For example, the OLE security object may be inserted in its entirety into the electronic document. FIG. 5 illustrates an example of an OLE security object 520 inserted into the document 510. A OLE object 530 is included in electronic document 510 to illustrate that the document may include multiple OLE security objects." Thus, Houser generally contemplates a embedding an object at "any location" meaning a defined location within the document. An object embedded at a predetermined and definite single location within an electronic document is not a watermark. Accordingly, Houser does not anticipate claim 32.

Independent claim 40 recites "said computer system receiving licensing information as an input and using said licensing information in an algorithm to identify a watermark in said software". As noted for claim 32, Houser does not disclose watermarking software and therefore does not anticipate claim 40. (Please also note that the "identify"ing limitation of claim 40 was not addressed in the OA.) Therefore, Houser does not anticipate claim 40.

Independent claim 52 recites "wherein said computer is programmed to embed a watermark into said software; wherein said watermark encodes at least one first license code, thereby resulting in a first license code encoded watermarked software."

Houser does not disclose embedding a watermark in software, or encoding a licence code in a watermark, for the reasons noted for claim 32. Therefore, Houser does not anticipate claim 52.

Independent claim 58 recites "said software product using license information entered via said input in response to said prompt in a routine designed to decode a first license code encoded in said software." Houser does not disclose software "designed to decode a first license code encoded in said software" in response to the user's entry of "license information." The OA rejected claim 58 citing the reasoning applied to dependent claim 34. However, claim 34 did not define software "designed to decode a first license code encoded in said software" in response to the user's entry of "license information." The OA cited Houser 9:20-25 in connection with claim 34. All that Houser 9:20-25 discloses is entry of user name and password; that provides no disclosure of claim 58's "designed to decode a first license code encoded in said software" in response to the user's entry of license information. Therefore, Houser does not anticipate claim 58.

Independent claim 59 recites "A method for encoding software code ...wherein said software code comprises a first code resource and provides a specified underlying functionality when installed on a computer system; and encoding, by said computer using at least a first license key and an encoding algorithm, said software code, to form a first license key encoded software code."

Houser does not disclose "encoding software code" and therefore does not disclose "encoding

software [that]...comprises a first code resource and provides a specified underlying functionality when installed on a computer system". Since Houser does not disclose "encoding software code" it also does not disclose doing so "using at least a first license key and an encoding algorithm". Therefore, Houser does not anticipate claim 59. (Please also note neither of these limitations is addressed in the OA.)

Independent claim 61 recites "A method for encoding software code". Houser does not disclose encoding software code. Claim 61 recites "...wherein said software code comprises a first code resource and provides a specified underlying functionality when installed on a computer system". As noted above for claim 59, Houser does not disclose this limitation (nor was it addressed in the OA). Claim 61 recites "modifying, by said computer, using a first license key and an encoding algorithm, said software code, to form a modified software code." Houser does not disclose encoding software code. Claim 61 recites "encoding said first code resource to form an encoded first code resource". Houser does not disclose encoding a code resource of the original electronic document. Claim 61 also recites "wherein said modified software code comprises said encoded first code resource, and a decode resource for decoding said encoded first code resource." Houser does not disclose this limitation (and please note that the OA did not address this limitation.) Finally, claim 61 recites "wherein said decode resource [contained in the "modified software code"] is configured to decode said encoded first code resource upon receipt of said first license key." Houser does not disclose this limitation (and please note that the OA did not address this limitation.)

Each dependent claim is allowable at least for the reasons noted for its independent claim.

2/27/2011

/RichardNeifeld#35,299/

RICHARD NEIFELD, REG. NO. 35,299

ATTORNEY OF RECORD

RAN

Date/Time code: February 27, 2011 (8:49pm)

Y:\Clients\SCOT Scott A Moskowitz and Wistaria Trading,

Inc\SCOT0014-4\Drafts\RemarksIRTOA_SCOT0014-4_2-26-2011.wpd

1-31. (Canceled)

32. (Currently Amended) A computer-based method for modifying software, comprising:

receiving, in a computer having a processor and memory, software, wherein said software provides a specified functionality;

embedding a watermark into said software, using said computer, said watermark encoding at least one first license code, thereby resulting in a first license code encoded watermarked software; ~~wherein said first license code encoded watermarked software.~~

33. (Previously Presented) The process of claim 32, wherein said embedding increases the complexity of code analysis and/or tampering with said first license code encoded watermarked software.

34. (Previously Presented) The process of claim 32, wherein said first license code encoded watermarked software is configured to query a user for personalization information during its installation.

35. (Previously Presented) The process of claim 32, wherein said watermark is accessible with a key.

36. (Previously Presented) The process of claim 35 wherein said key enables said first license code encoded watermarked software to provide said specified functionality.

37. (Previously Presented) The process according to claim 34, wherein said first license code encoded watermarked software is configured to determine said key from said personalization information.

38. (Original) The process according to claim 32, wherein the step of embedding the software with a watermark is performed during execution of the software.

39. (Previously Presented) The process according to claim 32, wherein said embedding modifies the structure of said software.

40. (Previously Presented) An article of manufacture comprising a machine readable medium, having thereon stored instructions adapted to be executed by a processor of a computer system, said computer system including a memory, which instructions when executed by said computer system result in a process comprising:

said computer system storing a software in said memory;

said computer system receiving licensing information as an input and using said licensing information in an algorithm to identify a watermark in said software.

41. (Currently Amended) The article of manufacture of claim 40, wherein said watermark encodes therein information defining an executable code providing a functionality of said software.

42. (Original) The article of manufacture of claim 40, wherein the watermark affects functionality of the watermarked software.

43. (Previously Presented) The article of manufacture of claim 41, wherein said instructions comprise decode instructions for said computer system to use said information to generate a decode key for decoding said software.

44. (Previously Presented) The article of manufacture of claim 43, wherein said identifying information comprises a license key, and said decode instructions instruct said computer to determine said license key from said information and to generate said decode key using said license key.

45. (Currently Amended) The article of manufacture of claim 40;
wherein said watermark encodes a license key;
said instructions include a prompt to enter licensing information;

wherein said software provides a certain functionality after receipt of licensing information in response to said prompt only if said licensing information comprises a license key encoded in said watermark.

46 – 51. (Canceled)

52. (Previously Presented) A computer-based system for modifying software, comprising:

a computer having a processor and memory;

wherein said computer is programmed to receive software that provides a specified functionality when installed on a computer system;

wherein said computer is programmed to embed a watermark into said software;

wherein said watermark encodes at least one first license code, thereby resulting in a first license code encoded watermarked software.

53. (Previously Presented) The system of claim 52 wherein said computer is programmed to use said at least one first license code as an input in an algorithm for embedding said watermark with said at least one first license code.

54. (Previously Presented) The system of claim 52 wherein said first license code encoded watermarked software is designed to prompt for entry of licensing information and only provides a certain functionality if licensing information entered in response to said prompt comprises at least one of said at least one first license code encoded in said watermark.

55. (Previously Presented) The system of claim 53, wherein said at least one first license code is fixed prior to distribution of the software.

56. (Previously Presented) The system of claim 52 wherein said at least one first license code comprises computer code that provides different functionality to said first license code encoded watermarked software compared to said software.

57. (Previously Presented) The system of claim 52, wherein said first license code encoded watermarked software is resistant to code analysis and/or tampering.

58. (Previously Presented) A method for licensed software use, the method comprising:

loading a software product on a computer, said computer comprising a processor, memory, an input, and an output, so that said computer is programmed to execute said software product; said software product outputting a prompt for input of license information; and said software product using license information entered via said input in response to said prompt in a routine designed to decode a first license code encoded in said software.

59. (Previously Presented) A method for encoding software code using a computer having a processor and memory, comprising:

storing a software code in said memory; wherein said software code comprises a first code resource and provides a specified underlying functionality when installed on a computer system; and encoding, by said computer using at least a first license key and an encoding algorithm, said software code, to form a first license key encoded software code.

60. (Previously Presented) The method of claim 59 wherein, when installed on a computer system, said first license key encoded software code will provide said specified underlying functionality only after receipt of said first license key.

61. (Previously Presented) A method for encoding software code using a computer having a processor and memory, comprising:

storing a software code in said memory; wherein said software code comprises a first code resource and provides a specified underlying functionality when installed on a computer system; and modifying, by said computer, using a first license key and an encoding algorithm, said software code, to form a modified software code; and

wherein said modifying comprises encoding said first code resource to form an encoded first code resource;

wherein said modified software code comprises said encoded first code resource, and a decode resource for decoding said encoded first code resource;

wherein said decode resource is configured to decode said encoded first code resource upon receipt of said first license key.

62. (Previously Presented) A method for encoding software code using a computer having a processor and memory, comprising:

storing a software code in said memory;

wherein said software code defines software code interrelationships between code resources that result in a specified underlying functionality when installed on a computer system; and

encoding, by said computer using at least a first license key and an encoding algorithm, said software code, to form a first license key encoded software code in which at least one of said software code interrelationships are encoded.

63. (Previously Presented) A method for encoding software code using a computer having a processor and memory, comprising:

storing a software code in said memory;

wherein said software code provides a specified underlying functionality when installed on a computer system;

encoding, by said computer using at least a first license key and an encoding algorithm, said software code, to form a first license key encoded software code;

encoding, by said computer using at least a second license key and an encoding algorithm, said software code, to form a second license key encoded software code;

wherein said first license key encoded software code is not identical to said second license key encoded software code if said first license key is not identical to said second license key.

64. (Previously Presented) The method of claim 63 wherein both said first license key encoded software code and said second license key encoded software code are capable of providing said specified underlying functionality when installed on a computer system.

ran

Date/time code: February 27, 2011 (7:25pm)

Y:\Clients\SCOT Scott A Moskowitz and Wistaria Trading,

Inc\SCOT0014-4\Drafts\Claims_SCOT0014-4_2-26-2011.wpd

IN THE SPECIFICATION

Please replace the paragraph on page 1 immediately following the header “CROSS-REFERENCE TO RELATED APPLICATIONS”, with the following paragraph:

This application is a division[[al]] of ~~U.S. Patent~~ Application Serial No. 10/602,777, filed June 25, 2003, now Patent No 7,664,263, issued February 16, 2010, which is a continuation of application of ~~U.S. Patent~~ Application Serial No. 09/046,627, filed March 24, 1998, now Patent No. 6,598,162, issued July 22, 2003, (which issued July 22, 2003, as U.S. Patent No. 6,59,162), which is a continuation-in-part of ~~U.S. Patent Application Serial No. 08/587,943, filed Jan. 17, 1996, (which issued April 28, 1998, as U.S. Patent No. 5,745,943)~~. The entire disclosure of U.S. Patent Application No. 09/046,627 (which issued July 22, 2003, as U.S. Patent No. 6,598,162) and ~~U.S. Patent Application Serial No. 08/587,943, filed Jan. 17, 1996, (which issued April 28, 1998, as U.S. Patent No. 5,745,943)~~ are hereby incorporated by reference in their entireties.

ran

February 26, 2011 (2:53pm)

Y:\Clients\SCOT Scott A Moskowitz and Wistaria Trading,

Inc\SCOT0014-4\Drafts\SpecificationAmendment_SCOT0014-4_2-7-2011.wpd

Electronic Acknowledgement Receipt

EFS ID:	9549026
Application Number:	11895388
International Application Number:	
Confirmation Number:	2103
Title of Invention:	Data protection method and device
First Named Inventor/Applicant Name:	Scott A. Moskowitz
Customer Number:	31518
Filer:	Richard A. Neifeld
Filer Authorized By:	
Attorney Docket Number:	SCOT0014-4
Receipt Date:	28-FEB-2011
Filing Date:	24-AUG-2007
Time Stamp:	15:50:28
Application Type:	Utility under 35 USC 111(a)

Payment information:

Submitted with Payment	no
------------------------	----

File Listing:

Document Number	Document Description	File Name	File Size(Bytes)/ Message Digest	Multi Part /.zip	Pages (if appl.)
1	Applicant Arguments/Remarks Made in an Amendment	Remarks\IRTOA_SCOT0014-4_2-26-2011.pdf	75060 <small>0180670b290d0e127fa7845aa8cbaa44a5713f1c</small>	no	7

Warnings:

Information:

2	Claims	Claims_SCOT0014-4_2-26-2011.pdf	29754 09f3340b5fbd10571f0e19ec0edfcfaa66a09435	no	7
Warnings:					
Information:					
3	Specification	SpecificationAmendment_SCO T0014-4_2-7-2011.pdf	18889 7fb6d3c40b33d9679292c3bf5daf042fb100521f	no	2
Warnings:					
Information:					
Total Files Size (in bytes):			123703		
<p>This Acknowledgement Receipt evidences receipt on the noted date by the USPTO of the indicated documents, characterized by the applicant, and including page counts, where applicable. It serves as evidence of receipt similar to a Post Card, as described in MPEP 503.</p> <p><u>New Applications Under 35 U.S.C. 111</u> If a new application is being filed and the application includes the necessary components for a filing date (see 37 CFR 1.53(b)-(d) and MPEP 506), a Filing Receipt (37 CFR 1.54) will be issued in due course and the date shown on this Acknowledgement Receipt will establish the filing date of the application.</p> <p><u>National Stage of an International Application under 35 U.S.C. 371</u> If a timely submission to enter the national stage of an international application is compliant with the conditions of 35 U.S.C. 371 and other applicable requirements a Form PCT/DO/EO/903 indicating acceptance of the application as a national stage submission under 35 U.S.C. 371 will be issued in addition to the Filing Receipt, in due course.</p> <p><u>New International Application Filed with the USPTO as a Receiving Office</u> If a new international application is being filed and the international application includes the necessary components for an international filing date (see PCT Article 11 and MPEP 1810), a Notification of the International Application Number and of the International Filing Date (Form PCT/RO/105) will be issued in due course, subject to prescriptions concerning national security, and the date shown on this Acknowledgement Receipt will establish the international filing date of the application.</p>					

Under the Paperwork Reduction Act of 1995, no persons are required to respond to a collection of information unless it displays a valid OMB control number.

PATENT APPLICATION FEE DETERMINATION RECORD Substitute for Form PTO-875					Application or Docket Number 11/895,388		Filing Date 08/24/2007		<input type="checkbox"/> To be Mailed			
APPLICATION AS FILED – PART I												
(Column 1)			(Column 2)			SMALL ENTITY <input checked="" type="checkbox"/>		OR OTHER THAN SMALL ENTITY				
FOR		NUMBER FILED	NUMBER EXTRA		RATE (\$)	FEE (\$)	OR		RATE (\$)	FEE (\$)		
<input type="checkbox"/> BASIC FEE <small>(37 CFR 1.16(a), (b), or (c))</small>		N/A	N/A		N/A		OR		N/A			
<input type="checkbox"/> SEARCH FEE <small>(37 CFR 1.16(k), (j), or (m))</small>		N/A	N/A		N/A		OR		N/A			
<input type="checkbox"/> EXAMINATION FEE <small>(37 CFR 1.16(c), (p), or (q))</small>		N/A	N/A		N/A		OR		N/A			
TOTAL CLAIMS <small>(37 CFR 1.16(i))</small>		minus 20 =	*		X \$ =		OR		X \$ =			
INDEPENDENT CLAIMS <small>(37 CFR 1.16(h))</small>		minus 3 =	*		X \$ =		OR		X \$ =			
<input type="checkbox"/> APPLICATION SIZE FEE <small>(37 CFR 1.16(s))</small>		If the specification and drawings exceed 100 sheets of paper, the application size fee due is \$250 (\$125 for small entity) for each additional 50 sheets or fraction thereof. See 35 U.S.C. 41(a)(1)(G) and 37 CFR 1.16(s).										
<input type="checkbox"/> MULTIPLE DEPENDENT CLAIM PRESENT <small>(37 CFR 1.16(j))</small>												
* If the difference in column 1 is less than zero, enter "0" in column 2.												
APPLICATION AS AMENDED – PART II										TOTAL		
(Column 1)			(Column 2)			SMALL ENTITY		OR OTHER THAN SMALL ENTITY				
AMENDMENT	02/28/2011		CLAIMS REMAINING AFTER AMENDMENT		HIGHEST NUMBER PREVIOUSLY PAID FOR	PRESENT EXTRA	RATE (\$)	ADDITIONAL FEE (\$)	OR		RATE (\$)	ADDITIONAL FEE (\$)
	Total <small>(37 CFR 1.16(i))</small>		* 27	Minus	** 33	= 0	X \$26 =	0	OR		X \$ =	
	Independent <small>(37 CFR 1.16(h))</small>		* 8	Minus	***8	= 0	X \$110 =	0	OR		X \$ =	
	<input type="checkbox"/> Application Size Fee <small>(37 CFR 1.16(s))</small>											
	<input type="checkbox"/> FIRST PRESENTATION OF MULTIPLE DEPENDENT CLAIM <small>(37 CFR 1.16(j))</small>											
							TOTAL ADD'L FEE	0	OR		TOTAL ADD'L FEE	
(Column 1)			(Column 2)			SMALL ENTITY		OR OTHER THAN SMALL ENTITY				
AMENDMENT			CLAIMS REMAINING AFTER AMENDMENT		HIGHEST NUMBER PREVIOUSLY PAID FOR	PRESENT EXTRA	RATE (\$)	ADDITIONAL FEE (\$)	OR		RATE (\$)	ADDITIONAL FEE (\$)
	Total <small>(37 CFR 1.16(i))</small>		*	Minus	**	=	X \$ =		OR		X \$ =	
	Independent <small>(37 CFR 1.16(h))</small>		*	Minus	***	=	X \$ =		OR		X \$ =	
	<input type="checkbox"/> Application Size Fee <small>(37 CFR 1.16(s))</small>											
	<input type="checkbox"/> FIRST PRESENTATION OF MULTIPLE DEPENDENT CLAIM <small>(37 CFR 1.16(j))</small>											
							TOTAL ADD'L FEE		OR		TOTAL ADD'L FEE	
* If the entry in column 1 is less than the entry in column 2, write "0" in column 3.												
** If the "Highest Number Previously Paid For" IN THIS SPACE is less than 20, enter "20".												
*** If the "Highest Number Previously Paid For" IN THIS SPACE is less than 3, enter "3".												
The "Highest Number Previously Paid For" (Total or Independent) is the highest number found in the appropriate box in column 1.												

Legal Instrument Examiner:
/GAIL WOOTEN/

This collection of information is required by 37 CFR 1.16. The information is required to obtain or retain a benefit by the public which is to file (and by the USPTO to process) an application. Confidentiality is governed by 35 U.S.C. 122 and 37 CFR 1.14. This collection is estimated to take 12 minutes to complete, including gathering, preparing, and submitting the completed application form to the USPTO. Time will vary depending upon the individual case. Any comments on the amount of time you require to complete this form and/or suggestions for reducing this burden, should be sent to the Chief Information Officer, U.S. Patent and Trademark Office, U.S. Department of Commerce, P.O. Box 1450, Alexandria, VA 22313-1450. DO NOT SEND FEES OR COMPLETED FORMS TO THIS ADDRESS. **SEND TO: Commissioner for Patents, P.O. Box 1450, Alexandria, VA 22313-1450.**

If you need assistance in completing the form, call 1-800-PTO-9199 and select option 2.



UNITED STATES PATENT AND TRADEMARK OFFICE

UNITED STATES DEPARTMENT OF COMMERCE
United States Patent and Trademark Office
Address: COMMISSIONER FOR PATENTS
P.O. Box 1450
Alexandria, Virginia 22313-1450
www.uspto.gov

Table with 5 columns: APPLICATION NO., FILING DATE, FIRST NAMED INVENTOR, ATTORNEY DOCKET NO., CONFIRMATION NO.
11/895,388 08/24/2007 Scott A. Moskowitz SCOT0014-4 2103

31518 7590 03/18/2011
NEIFELD IP LAW, PC
4813-B EISENHOWER AVENUE
ALEXANDRIA, VA 22304

Table with 1 column: EXAMINER

OKEKE, IZUNNA

Table with 2 columns: ART UNIT, PAPER NUMBER

2432

Table with 2 columns: NOTIFICATION DATE, DELIVERY MODE

03/18/2011

ELECTRONIC

Please find below and/or attached an Office communication concerning this application or proceeding.

The time period for reply, if any, is set in the attached communication.

Notice of the Office communication was sent electronically on above-indicated "Notification Date" to the following e-mail address(es):

general@neifeld.com
rneifeld@neifeld.com
rhahl@neifeld.com

Interview Summary	Application No.	Applicant(s)	
		11/895,388	MOSKOWITZ, SCOTT A.
	Examiner	Art Unit	
	IZUNNA OKEKE	2432	

All participants (applicant, applicant's representative, PTO personnel):

(1) IZUNNA OKEKE. (3) _____.

(2) RICHARD NEIFELD. (4) _____.

Date of Interview: 08 March 2011.

Type: a) Telephonic b) Video Conference
c) Personal [copy given to: 1) applicant 2) applicant's representative]

Exhibit shown or demonstration conducted: d) Yes e) No.
If Yes, brief description: _____.

Claim(s) discussed: 32.

Identification of prior art discussed: Houser et al. (US-5606609).

Agreement with respect to the claims f) was reached. g) was not reached. h) N/A.

Substance of Interview including description of the general nature of what was agreed to if an agreement was reached, or any other comments: Applicant's representative discussed claim 32 with reference to the applied reference, and explained that the reference fails to teach a watermark which encodes a license code. As applicant has already filed an After Final amendment, examiner noted applicant's argument and would respond to the AF appropriately.

(A fuller description, if necessary, and a copy of the amendments which the examiner agreed would render the claims allowable, if available, must be attached. Also, where no copy of the amendments that would render the claims allowable is available, a summary thereof must be attached.)

THE FORMAL WRITTEN REPLY TO THE LAST OFFICE ACTION MUST INCLUDE THE SUBSTANCE OF THE INTERVIEW. (See MPEP Section 713.04). If a reply to the last Office action has already been filed, APPLICANT IS GIVEN A NON-EXTENDABLE PERIOD OF THE LONGER OF ONE MONTH OR THIRTY DAYS FROM THIS INTERVIEW DATE, OR THE MAILING DATE OF THIS INTERVIEW SUMMARY FORM, WHICHEVER IS LATER, TO FILE A STATEMENT OF THE SUBSTANCE OF THE INTERVIEW. See Summary of Record of Interview requirements on reverse side or on attached sheet.

/IZUNNA OKEKE/ Examiner, Art Unit 2432	/Minh Dinh/ Primary Examiner, Art Unit 2432
---	--

Summary of Record of Interview Requirements

Manual of Patent Examining Procedure (MPEP), Section 713.04, Substance of Interview Must be Made of Record

A complete written statement as to the substance of any face-to-face, video conference, or telephone interview with regard to an application must be made of record in the application whether or not an agreement with the examiner was reached at the interview.

Title 37 Code of Federal Regulations (CFR) § 1.133 Interviews

Paragraph (b)

In every instance where reconsideration is requested in view of an interview with an examiner, a complete written statement of the reasons presented at the interview as warranting favorable action must be filed by the applicant. An interview does not remove the necessity for reply to Office action as specified in §§ 1.111, 1.135. (35 U.S.C. 132)

37 CFR §1.2 Business to be transacted in writing.

All business with the Patent or Trademark Office should be transacted in writing. The personal attendance of applicants or their attorneys or agents at the Patent and Trademark Office is unnecessary. The action of the Patent and Trademark Office will be based exclusively on the written record in the Office. No attention will be paid to any alleged oral promise, stipulation, or understanding in relation to which there is disagreement or doubt.

The action of the Patent and Trademark Office cannot be based exclusively on the written record in the Office if that record is itself incomplete through the failure to record the substance of interviews.

It is the responsibility of the applicant or the attorney or agent to make the substance of an interview of record in the application file, unless the examiner indicates he or she will do so. It is the examiner's responsibility to see that such a record is made and to correct material inaccuracies which bear directly on the question of patentability.

Examiners must complete an Interview Summary Form for each interview held where a matter of substance has been discussed during the interview by checking the appropriate boxes and filling in the blanks. Discussions regarding only procedural matters, directed solely to restriction requirements for which interview recordation is otherwise provided for in Section 812.01 of the Manual of Patent Examining Procedure, or pointing out typographical errors or unreadable script in Office actions or the like, are excluded from the interview recordation procedures below. Where the substance of an interview is completely recorded in an Examiners Amendment, no separate Interview Summary Record is required.

The Interview Summary Form shall be given an appropriate Paper No., placed in the right hand portion of the file, and listed on the "Contents" section of the file wrapper. In a personal interview, a duplicate of the Form is given to the applicant (or attorney or agent) at the conclusion of the interview. In the case of a telephone or video-conference interview, the copy is mailed to the applicant's correspondence address either with or prior to the next official communication. If additional correspondence from the examiner is not likely before an allowance or if other circumstances dictate, the Form should be mailed promptly after the interview rather than with the next official communication.

The Form provides for recordation of the following information:

- Application Number (Series Code and Serial Number)
- Name of applicant
- Name of examiner
- Date of interview
- Type of interview (telephonic, video-conference, or personal)
- Name of participant(s) (applicant, attorney or agent, examiner, other PTO personnel, etc.)
- An indication whether or not an exhibit was shown or a demonstration conducted
- An identification of the specific prior art discussed
- An indication whether an agreement was reached and if so, a description of the general nature of the agreement (may be by attachment of a copy of amendments or claims agreed as being allowable). Note: Agreement as to allowability is tentative and does not restrict further action by the examiner to the contrary.
- The signature of the examiner who conducted the interview (if Form is not an attachment to a signed Office action)

It is desirable that the examiner orally remind the applicant of his or her obligation to record the substance of the interview of each case. It should be noted, however, that the Interview Summary Form will not normally be considered a complete and proper recordation of the interview unless it includes, or is supplemented by the applicant or the examiner to include, all of the applicable items required below concerning the substance of the interview.

A complete and proper recordation of the substance of any interview should include at least the following applicable items:

- 1) A brief description of the nature of any exhibit shown or any demonstration conducted,
- 2) an identification of the claims discussed,
- 3) an identification of the specific prior art discussed,
- 4) an identification of the principal proposed amendments of a substantive nature discussed, unless these are already described on the Interview Summary Form completed by the Examiner,
- 5) a brief identification of the general thrust of the principal arguments presented to the examiner,
(The identification of arguments need not be lengthy or elaborate. A verbatim or highly detailed description of the arguments is not required. The identification of the arguments is sufficient if the general nature or thrust of the principal arguments made to the examiner can be understood in the context of the application file. Of course, the applicant may desire to emphasize and fully describe those arguments which he or she feels were or might be persuasive to the examiner.)
- 6) a general indication of any other pertinent matters discussed, and
- 7) if appropriate, the general results or outcome of the interview unless already described in the Interview Summary Form completed by the examiner.

Examiners are expected to carefully review the applicant's record of the substance of an interview. If the record is not complete and accurate, the examiner will give the applicant an extendable one month time period to correct the record.

Examiner to Check for Accuracy

If the claims are allowable for other reasons of record, the examiner should send a letter setting forth the examiner's version of the statement attributed to him or her. If the record is complete and accurate, the examiner should place the indication, "Interview Record OK" on the paper recording the substance of the interview along with the date and the examiner's initials.



UNITED STATES PATENT AND TRADEMARK OFFICE

UNITED STATES DEPARTMENT OF COMMERCE
United States Patent and Trademark Office
Address: COMMISSIONER FOR PATENTS
P.O. Box 1450
Alexandria, Virginia 22313-1450
www.uspto.gov

APPLICATION NO.	FILING DATE	FIRST NAMED INVENTOR	ATTORNEY DOCKET NO.	CONFIRMATION NO.
11/895,388	08/24/2007	Scott A. Moskowitz	SCOT0014-4	2103
31518	7590	04/01/2011	EXAMINER	
NEIFELD IP LAW, PC 4813-B EISENHOWER AVENUE ALEXANDRIA, VA 22304			OKEKE, IZUNNA	
			ART UNIT	PAPER NUMBER
			2432	
			NOTIFICATION DATE	DELIVERY MODE
			04/01/2011	ELECTRONIC

Please find below and/or attached an Office communication concerning this application or proceeding.

The time period for reply, if any, is set in the attached communication.

Notice of the Office communication was sent electronically on above-indicated "Notification Date" to the following e-mail address(es):

general@neifeld.com
rneifeld@neifeld.com
rhahl@neifeld.com

Office Action Summary	Application No.	Applicant(s)	
	11/895,388	MOSKOWITZ, SCOTT A.	
	Examiner	Art Unit	
	IZUNNA OKEKE	2432	

-- The MAILING DATE of this communication appears on the cover sheet with the correspondence address --
Period for Reply

A SHORTENED STATUTORY PERIOD FOR REPLY IS SET TO EXPIRE 3 MONTH(S) OR THIRTY (30) DAYS, WHICHEVER IS LONGER, FROM THE MAILING DATE OF THIS COMMUNICATION.

- Extensions of time may be available under the provisions of 37 CFR 1.136(a). In no event, however, may a reply be timely filed after SIX (6) MONTHS from the mailing date of this communication.
- If NO period for reply is specified above, the maximum statutory period will apply and will expire SIX (6) MONTHS from the mailing date of this communication.
- Failure to reply within the set or extended period for reply will, by statute, cause the application to become ABANDONED (35 U.S.C. § 133). Any reply received by the Office later than three months after the mailing date of this communication, even if timely filed, may reduce any earned patent term adjustment. See 37 CFR 1.704(b).

Status

- 1) Responsive to communication(s) filed on 28 February 2011.
- 2a) This action is **FINAL**. 2b) This action is non-final.
- 3) Since this application is in condition for allowance except for formal matters, prosecution as to the merits is closed in accordance with the practice under *Ex parte Quayle*, 1935 C.D. 11, 453 O.G. 213.

Disposition of Claims

- 4) Claim(s) 32-45 and 52-64 is/are pending in the application.
 - 4a) Of the above claim(s) _____ is/are withdrawn from consideration.
- 5) Claim(s) _____ is/are allowed.
- 6) Claim(s) 32-45 and 52-64 is/are rejected.
- 7) Claim(s) _____ is/are objected to.
- 8) Claim(s) _____ are subject to restriction and/or election requirement.

Application Papers

- 9) The specification is objected to by the Examiner.
- 10) The drawing(s) filed on _____ is/are: a) accepted or b) objected to by the Examiner.
 Applicant may not request that any objection to the drawing(s) be held in abeyance. See 37 CFR 1.85(a).
 Replacement drawing sheet(s) including the correction is required if the drawing(s) is objected to. See 37 CFR 1.121(d).
- 11) The oath or declaration is objected to by the Examiner. Note the attached Office Action or form PTO-152.

Priority under 35 U.S.C. § 119

- 12) Acknowledgment is made of a claim for foreign priority under 35 U.S.C. § 119(a)-(d) or (f).
 - a) All b) Some * c) None of:
 - 1. Certified copies of the priority documents have been received.
 - 2. Certified copies of the priority documents have been received in Application No. _____.
 - 3. Copies of the certified copies of the priority documents have been received in this National Stage application from the International Bureau (PCT Rule 17.2(a)).

* See the attached detailed Office action for a list of the certified copies not received.

Attachment(s)

- 1) Notice of References Cited (PTO-892)
- 2) Notice of Draftsperson's Patent Drawing Review (PTO-948)
- 3) Information Disclosure Statement(s) (PTO/SB/08)
 Paper No(s)/Mail Date 11/19/2010.
- 4) Interview Summary (PTO-413)
 Paper No(s)/Mail Date. _____.
- 5) Notice of Informal Patent Application
- 6) Other: _____.

DETAILED ACTION

Response to Arguments

1. Applicant's arguments with respect to claim 32-45 and 52-64 have been considered but are moot in view of the new ground(s) of rejection.

In reference to the argument presented on page 6 of applicant's argument/remark, applicant argues that Houser (US-5606609) does not disclose a watermark being embedded. Houser discloses a digitally watermarked graphic file which is an electronic representation of a difficult to forge image or icon on media file (See Houser, Col 16, Line 59-65). A digitally watermarked graphic file can be interpreted as being embedded with a watermark. The use of Houser in the current action is to teach that digital watermarks are a known concept prior to the present invention and are used to encode/insert certain information into a media. The primary reference discloses embedding/inserting identification code into software but does not teach it as a digital watermark. Houser was used to remedy the deficiencies of the primary art in the sense that digital watermarks protects the encoded information from tampering/forgery and inserting Holmes' identification data as a watermark (thereby resulting in a watermarked software code having the identification data) would protect the identification data against tampering because it would be difficult remove from the software or forge.

In reference to the portions of the argument/response that deals with the 112 rejection presented in the last Office Action, the portions of the disclosure cited by applicant fails to explicitly disclose or define "interrelationships" and in the absence of such a definition, the term is given a broad reasonable interpretation. "Interrelationship" can be a relationship between two object and the fact that both objects are alike (code resources) can be defined as an

"interrelationship" between them. Also, a careful consideration of the portions cited by applicant to support the claimed limitation offers differing perspectives on the definition of "software code interrelationships" (on Page 4, Para 1 and 2 of the arguments/remarks). For instance, in the first paragraph of Page 4, applicant cites the portion "the application contains a special code resource which knows about all other code resources in memory" and argues that it provides support for the claimed limitation. In Para 2, applicant further cites another portion "during execution time, this special code resource, called a memory scheduler, can be called periodically, or at random or pseudo random intervals....." and also argues that it provides support for the limitation. These are both differing interpretations and fails to explicitly recite or define "software code interrelationships". Therefore in the absence of a clear and concise definition of "software code interrelationships" recited in the claims, the 112 rejection is maintained because one can't correctly ascertain the metes and bounds of the invention based on the claim language. This reasoning is also applied to other limitations recited in the claims and rejected for not being clearly and explicitly disclosed/defined in the specification.

Claim Rejections - 35 USC § 112

2. The following is a quotation of the first paragraph of 35 U.S.C. 112:

The specification shall contain a written description of the invention, and of the manner and process of making and using it, in such full, clear, concise, and exact terms as to enable any person skilled in the art to which it pertains, or with which it is most nearly connected, to make and use the same and shall set forth the best mode contemplated by the inventor of carrying out his invention.

3. Claims 62-64 are rejected under 35 U.S.C. 112, first paragraph, as failing to comply with the written description requirement. The claim(s) contains subject matter which was not described in the specification in such a way as to reasonably convey to one skilled in the relevant

art that the inventor(s), at the time the application was filed, had possession of the claimed invention.

Claims 62 recites in part “wherein said software code defines software code interrelationships between code resources” and “to form a first license key encoded software code in which at least one of said software code interrelationship are encoded”. The specification provides no support for this limitation as it fails to teach or mention “software code interrelationships”, how the software code defines interrelationships between code resources and how it is encoded to form a first license key encoded software code. Applicant is asked to identify the section of the specification that provides support for claim 62.

Claim 63 and dependent claim 64 recites in part “encoding, by said computer using at least a first license key and an encoding algorithm, said software code, to form a second license key encoded software code; wherein said first license key encoded software code is not identical to said second license key encoded software code”. There is also no disclosure that supports this limitation in the specification. There is no disclosure of using a “second license key” to encode a software code to form a “second license key encoded software code” wherein a first license key encoded software code is not identical to a second license key encoded software code. Applicant is also asked to point out the section of the specification that clearly provides support for claims 63 and 64.

4. The following is a quotation of the second paragraph of 35 U.S.C. 112:

The specification shall conclude with one or more claims particularly pointing out and distinctly claiming the subject matter which the applicant regards as his invention.

5. Claim 37 recites the limitation "determine said key". There is insufficient antecedent basis for this limitation in the claim. There is no former recitation of a key in claim 37 or the claims it depends on to ascertain which key the claim refers to.

Claim Rejections - 35 USC § 103

6. The following is a quotation of 35 U.S.C. 103(a) which forms the basis for all obviousness rejections set forth in this Office action:

(a) A patent may not be obtained though the invention is not identically disclosed or described as set forth in section 102 of this title, if the differences between the subject matter sought to be patented and the prior art are such that the subject matter as a whole would have been obvious at the time the invention was made to a person having ordinary skill in the art to which said subject matter pertains. Patentability shall not be negated by the manner in which the invention was made.

7. Claims 32-45 and 52-64 are rejected under 35 U.S.C. 103(a) as being unpatentable over Holmes et al. (US-5287407), and further in view of Houser et al. (US-5606609).

a. Referring to claims 32, 40, 41, 45, 52, 55, 58 and 59:

Regarding claims 32, 40, 41, 45, 52, 55, 58 and 59, Holmes teaches a computer-based method for modifying software, comprising: receiving, in a computer having a processor and memory, software, wherein said software provides a specified functionality (Col 1, Line 60 thru Col 2, Line 4 and Line 10-20 and Col 3, Line 38-45 and Col 3, Line 67 thru Col 4, Line 4... method for modifying software which provides a specified functionality when executed by embedding a code in the software such as a unique identifying data (which could serve as a license for the software) associated with a user or the system or the software)

Holmes teaches embedding an identification data into the software. Holmes does not teach embedding the data as a watermark. However, embedding information as an electronic watermark is well known in the art. For instance, Houser teaches embedding information as a digital watermark into a media (See Houser, Col 16, Line 59-65.... electronically watermarked

Art Unit: 2432

graphic/video file). Therefore, one of ordinary skill in the art would have been motivated to modify Holmes' teaching by embedding the identification data as a watermark wherein the watermark cannot be forged and is also difficult to remove for the purpose of protecting the watermarked software and preventing unauthorized users from tampering with the identification data.

a. Referring to claims 33 and 57:

Regarding claims 33 and 57, the combination of Holmes and Houser teaches the process of claim 32, wherein said embedding increases the complexity of code analysis and/or tampering with said first license code encoded watermarked software (See the reason for watermarking identification data in the rejection in claim 32 and Holmes, Col 2, Line 2-4... said embedding of identification code enhances software security against tampering)

a. Referring to claims 34 and 54:

Regarding claims 34 and 54, the combination of Holmes and Houser teaches the process of claim 32, wherein said first license code encoded watermarked software is configured to query a user for personalization information during its installation (Col 3, Line 67 thru Col 4, Line 12... verifying the embedded identification data during software installation/copying).

a. Referring to claims 35 and 53:

Regarding claims 35 and 53, the combination of Holmes and Houser teaches the process of claim 32, wherein said watermark is accessible with a key (See Houser, Col 9, Line 37-60...watermark is protected with a key which is used to decode the watermark).

a. Referring to claims 36 and 60:

Regarding claims 36 and 60, the combination of Holmes and Houser teaches the process of claim 35 wherein said key enables said first license code encoded watermarked software to provide said specified functionality (Col 4, Line 16-17... executing/copying the software code based on successful verification).

a. Referring to claims 37 and 44:

Regarding claims 37 and 44, the combination of Holmes and Houser teaches the process according to claim 34, wherein said first license code encoded watermarked software is configured to determine said key from said personalization information (See Houser, Col 9, Line 37-60... determining key from password/identification data).

a. Referring to claim 38:

Regarding claim 38, the combination of Holmes and Houser teaches the process according to claim 32, wherein the step of embedding the software with a watermark is performed during execution of the software (Col 3, Line 38-46) .

a. Referring to claim 39:

Regarding claim 39, the combination of Holmes and Houser teaches the process according to claim 3 2, wherein said embedding modifies the structure of said software (Fig 1 and Col 3, Line 38-46... embedding the code modifies the software code from its original structure).

a. Referring to claims 42 and 56:

Regarding claims 42 and 56, the combination of Holmes and Houser teaches the article of manufacture of claim 40, wherein the watermark affects functionality of the watermarked

software (Col 3, Line 67 thru Col 4, Line 4... the protection affects the functionality of the software by first running an verification process before execution).

a. Referring to claim 43:

Regarding claim 43, the combination of Holmes and Houser teaches the article of manufacture of claim 41, wherein said instructions comprise decode instructions for said computer system to use said information to generate a decode key for decoding said software (Col 3, Line 67 thru Col 4, Line 4... identification data used to verify/decode the software for installation/copying).

a. Referring to claim 61:

Regarding claim 61, the combination of Holmes and Houser teaches A method for encoding software code using a computer having a processor and memory, comprising: storing a software code in said memory; wherein said software code comprises a first code resource and provides a specified underlying functionality when installed on a computer system (See the rejection in claim 32); and modifying, by said computer, using a first license key and an encoding algorithm, said software code, to form a modified software code; and wherein said modifying comprises encoding said first code resource to form an encoded first code resource (See the rejection in claim 32... modifying the software code by embedding a code resource in the software code); wherein said modified software code comprises said encoded first code resource, and a decode resource for decoding said encoded first code resource; wherein said decode resource is configured to decode said encoded first code resource upon receipt of said first license key (See the rejection in claim 43) .

Conclusion

Any inquiry concerning this communication or earlier communications from the examiner should be directed to IZUNNA OKEKE whose telephone number is (571) 270-3854. The examiner can normally be reached on Monday - Thursday.

If attempts to reach the examiner by telephone are unsuccessful, the examiner's supervisor, Gilberto Barron can be reached on (571) 270-3799. The fax phone number for the organization where this application or proceeding is assigned is 571-273-8300.

Information regarding the status of an application may be obtained from the Patent Application Information Retrieval (PAIR) system. Status information for published applications may be obtained from either Private PAIR or Public PAIR. Status information for unpublished applications is available through Private PAIR only. For more information about the PAIR system, see <http://pair-direct.uspto.gov>. Should you have questions on access to the Private PAIR system, contact the Electronic Business Center (EBC) at 866-217-9197 (toll-free). If you would like assistance from a USPTO Customer Service Representative or access to the automated information system, call 800-786-9199 (IN USA OR CANADA) or 571-272-1000.

/IZUNNA OKEKE/
Examiner, Art Unit 2432

/Minh Dinh/
Primary Examiner, Art Unit 2432

Notice of References Cited	Application/Control No. 11/895,388	Applicant(s)/Patent Under Reexamination MOSKOWITZ, SCOTT A.	
	Examiner IZUNNA OKEKE	Art Unit 2432	Page 1 of 1

U.S. PATENT DOCUMENTS

*	Document Number Country Code-Number-Kind Code	Date MM-YYYY	Name	Classification
*	A US-5,287,407	02-1994	Holmes, Keith	705/58
*	B US-5,606,609	02-1997	Houser et al.	713/179
	C US-			
	D US-			
	E US-			
	F US-			
	G US-			
	H US-			
	I US-			
	J US-			
	K US-			
	L US-			
	M US-			

FOREIGN PATENT DOCUMENTS

*	Document Number Country Code-Number-Kind Code	Date MM-YYYY	Country	Name	Classification
	N				
	O				
	P				
	Q				
	R				
	S				
	T				

NON-PATENT DOCUMENTS

*	Include as applicable: Author, Title Date, Publisher, Edition or Volume, Pertinent Pages)
U	
V	
W	
X	

*A copy of this reference is not being furnished with this Office action. (See MPEP § 707.05(a).)
Dates in MM-YYYY format are publication dates. Classifications may be US or foreign.

<i>Index of Claims</i> 	Application/Control No. 11895388	Applicant(s)/Patent Under Reexamination MOSKOWITZ, SCOTT A.
	Examiner IZUNNA OKEKE	Art Unit 2432

✓	Rejected	-	Cancelled	N	Non-Elected	A	Appeal
=	Allowed	÷	Restricted	I	Interference	O	Objected

Claims renumbered in the same order as presented by applicant
 CPA
 T.D.
 R.1.47

CLAIM		DATE							
Final	Original	03/22/2010	11/11/2010	03/17/2011					
	32	✓	✓	✓					
	33	✓	✓	✓					
	34	✓	✓	✓					
	35	✓	✓	✓					
	36	✓	✓	✓					
	37	✓	✓	✓					
	38	✓	✓	✓					
	39	✓	✓	✓					
	40	✓	✓	✓					
	41	✓	✓	✓					
	42	✓	✓	✓					
	43	✓	✓	✓					
	44	✓	✓	✓					
	45	✓	✓	✓					
	52	✓	✓	✓					
	53	✓	✓	✓					
	54	✓	✓	✓					
	55	✓	✓	✓					
	56	✓	✓	✓					
	57	✓	✓	✓					
	58	✓	✓	✓					
	59	✓	✓	✓					
	60		✓	✓					
	61		✓	✓					
	62		✓	✓					
	63		✓	✓					
	64		✓	✓					

Search Notes 	Application/Control No. 11895388	Applicant(s)/Patent Under Reexamination MOSKOWITZ, SCOTT A.
	Examiner IZUNNA OKEKE	Art Unit 2432

SEARCHED			
Class	Subclass	Date	Examiner

SEARCH NOTES		
Search Notes	Date	Examiner
Updated Text Search (See History)	3/16/2011	IO
Updated Keyword + Classification Search (See History)	3/16/2011	IO
Search (713/165, 713/176, 713/161, 380/201, 380/228, 380/229) (See History)	3/16/2011	IO
NPL Search	3/16/2011	IO

INTERFERENCE SEARCH			
Class	Subclass	Date	Examiner

--	--

EAST Search History

EAST Search History (Prior Art)

Ref #	Hits	Search Query	DBs	Default Operator	Plurals	Time Stamp
S1	3060	(watermark near3 (software or program or application))	US-PGPUB; USPAT; USOCR; FPRS; EPO; JPO; DERWENT; IBM_TDB	AND	ON	2011/03/16 13:21
S3	193	(watermark near3 (software or program or application)) and (@ad<"19960117" or @rlad<"19960117")	US-PGPUB; USPAT; USOCR; FPRS; EPO; JPO; DERWENT; IBM_TDB	AND	ON	2011/03/16 13:23
S7	21	(watermark near3 (software or program or application)) and (@ad<"19960117")	US-PGPUB; USPAT; USOCR; FPRS; EPO; JPO; DERWENT; IBM_TDB	AND	ON	2011/03/16 22:01
S9	94	(watermark same (software or program or application)) and (@ad<"19960117")	US-PGPUB; USPAT; USOCR; FPRS; EPO; JPO; DERWENT; IBM_TDB	AND	ON	2011/03/16 22:26

S10	51	(watermark with (software or program or application)) and (@ad<"19960117")	US-PGPUB; USPAT; USOCR; FPRS; EPO; JPO; DERWENT; IBM_TDB	AND	ON	2011/03/16 22:26
S12	3	(watermark same ((software or program or application) with protect\$3)) and (@ad<"19960117")	US-PGPUB; USPAT; USOCR; FPRS; EPO; JPO; DERWENT; IBM_TDB	AND	ON	2011/03/16 22:52
S14	3	((watermark or stega\$5) same ((software or program or application) with protect\$3)) and (@ad<"19960117")	US-PGPUB; USPAT; USOCR; FPRS; EPO; JPO; DERWENT; IBM_TDB	AND	ON	2011/03/16 23:08
S15	3	((watermark or steganograph\$5) same ((software or program or application) with protect\$3)) and (@ad<"19960117")	US-PGPUB; USPAT; USOCR; FPRS; EPO; JPO; DERWENT; IBM_TDB	AND	ON	2011/03/16 23:08
S16	8	((watermark or steganograph\$5) same ((software or program or application) same protect\$3)) and (@ad<"19960117")	US-PGPUB; USPAT; USOCR; FPRS; EPO; JPO; DERWENT; IBM_TDB	AND	ON	2011/03/16 23:09

S18	15	((watermark or steganograph\$5) same ((software or program or application) and protect\$3)) and (@ad<"19960117")	US-PGPUB; USPAT; USOCR; FPRS; EPO; JPO; DERWENT; IBM_TDB	AND	ON	2011/03/16 23:22
S19	1361	((embed\$4) same ((software or program or application) and protect\$3)) and (@ad<"19960117")	US-PGPUB; USPAT; USOCR; FPRS; EPO; JPO; DERWENT; IBM_TDB	AND	ON	2011/03/16 23:23
S20	101	((embed\$4) same ((software or program or application) near3 protect\$3)) and (@ad<"19960117")	US-PGPUB; USPAT; USOCR; FPRS; EPO; JPO; DERWENT; IBM_TDB	AND	ON	2011/03/16 23:23
S21	3	((watermark or (crypto\$5 near3 code)) same ((software or program or application) near3 protect\$3)) and (@ad<"19960117")	US-PGPUB; USPAT; USOCR; FPRS; EPO; JPO; DERWENT; IBM_TDB	AND	ON	2011/03/17 00:02
S22	6	((watermark or (cryptograph\$5 near3 code)) same ((software or program or application) near3 protect\$3)) and (@ad<"19960117")	US-PGPUB; USPAT; USOCR; FPRS; EPO; JPO; DERWENT; IBM_TDB	AND	ON	2011/03/17 00:03

S23	7	((watermark or (cryptograph\$5 near3 code)) same ((software or program or application) near5 protect\$3)) and (@ad<"19960117")	US-PGPUB; USPAT; USOCR; FPRS; EPO; JPO; DERWENT; IBM_TDB	AND	ON	2011/03/17 00:03
S24	49	((watermark or (cryptograph\$5 near3 code)) and ((software or program or application) near5 protect\$3)) and (@ad<"19960117")	US-PGPUB; USPAT; USOCR; FPRS; EPO; JPO; DERWENT; IBM_TDB	AND	ON	2011/03/17 00:03
S25	39	((watermark or (cryptograph\$5 near3 code)) and ((software or program or application) near3 protect\$3)) and (@ad<"19960117")	US-PGPUB; USPAT; USOCR; FPRS; EPO; JPO; DERWENT; IBM_TDB	AND	ON	2011/03/17 00:04
S26	22	((watermark or (cryptograph\$5 near3 code)) and ((software) near3 protect\$3)) and (@ad<"19960117")	US-PGPUB; USPAT; USOCR; FPRS; EPO; JPO; DERWENT; IBM_TDB	AND	ON	2011/03/17 00:04
S27	113	((watermark or (cryptograph\$5)) and ((software) near3 protect\$3)) and (@ad<"19960117")	US-PGPUB; USPAT; USOCR; FPRS; EPO; JPO; DERWENT; IBM_TDB	AND	ON	2011/03/17 00:06

S28	8284	713/165,176,161,167;380/201,228,229.ccls.	US-PGPUB; USPAT; USOCR; FPRS; EPO; JPO; DERWENT; IBM_TDB	AND	ON	2011/03/17 10:03
S29	1361	((embed\$4) same ((software or program or application) and protect\$3)) and (@ad<"19960117")	US-PGPUB; USPAT; USOCR; FPRS; EPO; JPO; DERWENT; IBM_TDB	AND	ON	2011/03/17 10:04
S30	11	S29 and S28	US-PGPUB; USPAT; USOCR; FPRS; EPO; JPO; DERWENT; IBM_TDB	AND	ON	2011/03/17 10:04
S31	3065	(watermark near3 (software or program or application))	US-PGPUB; USPAT; USOCR; FPRS; EPO; JPO; DERWENT; IBM_TDB	AND	ON	2011/03/17 10:06
S32	638	S31 and S28	US-PGPUB; USPAT; USOCR; FPRS; EPO; JPO; DERWENT; IBM_TDB	AND	ON	2011/03/17 10:06
S33	101	((embed\$4) same ((software or program or application) near3 protect\$3)) and (@ad<"19960117")	US-PGPUB; USPAT; USOCR; FPRS; EPO; JPO; DERWENT; IBM_TDB	AND	ON	2011/03/17 10:06

S34	1	S28 and S33	US-PGPUB; USPAT; USOCR; FPRS; EPO; JPO; DERWENT; IBM_TDB	AND	ON	2011/03/17 10:06
S35	113	((watermark or (cryptograph\$5)) and ((software) near3 protect\$3)) and (@ad<"19960117")	US-PGPUB; USPAT; USOCR; FPRS; EPO; JPO; DERWENT; IBM_TDB	AND	ON	2011/03/17 10:06
S36	20	S28 and S35	US-PGPUB; USPAT; USOCR; FPRS; EPO; JPO; DERWENT; IBM_TDB	AND	ON	2011/03/17 10:06
S38	94	(watermark same ((software or program or application))) and (@ad<"19960117")	US-PGPUB; USPAT; USOCR; FPRS; EPO; JPO; DERWENT; IBM_TDB	AND	ON	2011/03/17 11:56
S39	21	(watermark near3 ((software or program or application))) and (@ad<"19960117")	US-PGPUB; USPAT; USOCR; FPRS; EPO; JPO; DERWENT; IBM_TDB	AND	ON	2011/03/17 11:57
S40	5	(watermark\$3 adj ((software or program or application))) and (@ad<"19960117")	US-PGPUB; USPAT; USOCR; FPRS; EPO; JPO; DERWENT; IBM_TDB	AND	ON	2011/03/17 11:57

S41	11	(watermark same ((software))) and (@ad<"19960117")	US-PGPUB; USPAT; USOCR; FPRS; EPO; JPO; DERWENT; IBM_TDB	AND	ON	2011/03/17 11:57
S42	12	(watermark\$3 same ((software))) and (@ad<"19960117")	US-PGPUB; USPAT; USOCR; FPRS; EPO; JPO; DERWENT; IBM_TDB	AND	ON	2011/03/17 11:59
S43	51	(watermark with (software or program or application)) and (@ad<"19960117")	US-PGPUB; USPAT; USOCR; FPRS; EPO; JPO; DERWENT; IBM_TDB	AND	ON	2011/03/17 12:03
S44	95	((watermark or steganograph\$5) same ((software or program or application))) and (@ad<"19960117")	US-PGPUB; USPAT; USOCR; FPRS; EPO; JPO; DERWENT; IBM_TDB	AND	ON	2011/03/17 12:07
S45	36	((watermark or steganograph\$5) near5 ((software or program or application))) and (@ad<"19960117")	US-PGPUB; USPAT; USOCR; FPRS; EPO; JPO; DERWENT; IBM_TDB	AND	ON	2011/03/17 12:07
S46	51	((watermark or steganograph\$5) with ((software or program or application))) and (@ad<"19960117")	US-PGPUB; USPAT; USOCR; FPRS; EPO; JPO; DERWENT; IBM_TDB	AND	ON	2011/03/17 12:08

S47	5	((watermark or steganograph\$5) with ((software))) and (@ad<"19960117")	US-PGPUB; USPAT; USOCR; FPRS; EPO; JPO; DERWENT; IBM_TDB	AND	ON	2011/03/17 12:09
S48	396	((watermark or steganograph\$5) and ((software or program or application))) and (@ad<"19960117")	US-PGPUB; USPAT; USOCR; FPRS; EPO; JPO; DERWENT; IBM_TDB	AND	ON	2011/03/17 12:11
S49	82	((watermark or steganograph\$5) and ((software))) and (@ad<"19960117")	US-PGPUB; USPAT; USOCR; FPRS; EPO; JPO; DERWENT; IBM_TDB	AND	ON	2011/03/17 12:11
S50	81	((watermark) and ((software))) and (@ad<"19960117")	US-PGPUB; USPAT; USOCR; FPRS; EPO; JPO; DERWENT; IBM_TDB	AND	ON	2011/03/17 12:12
S51	36	(watermark near5 ((software or program or application))) and (@ad<"19960117")	US-PGPUB; USPAT; USOCR; FPRS; EPO; JPO; DERWENT; IBM_TDB	AND	ON	2011/03/17 12:20
S52	44	(watermark near5 ((code or software or program or application))) and (@ad<"19960117")	US-PGPUB; USPAT; USOCR; FPRS; EPO; JPO; DERWENT; IBM_TDB	AND	ON	2011/03/17 12:20

S53	48	(watermark\$3 near5 (code or software or program or application)) and (@ad<"19960117")	US-PGPUB; USPAT; USOCR; FPRS; EPO; JPO; DERWENT; IBM_TDB	AND	ON	2011/03/17 12:31
S54	83	(watermark\$3 with (code or software or program or application)) and (@ad<"19960117")	US-PGPUB; USPAT; USOCR; FPRS; EPO; JPO; DERWENT; IBM_TDB	AND	ON	2011/03/17 12:32
S55	11	(watermark\$3 near3 (protect\$3)) and (@ad<"19960117")	US-PGPUB; USPAT; USOCR; FPRS; EPO; JPO; DERWENT; IBM_TDB	AND	ON	2011/03/17 12:36
S56	10	((watermark near5 signature) and ((software or program or application))) and (@ad<"19960117")	US-PGPUB; USPAT; USOCR; FPRS; EPO; JPO; DERWENT; IBM_TDB	AND	ON	2011/03/17 12:44
S57	1	(digital same (watermark near5 signature) and ((software or program or application))) and (@ad<"19960117")	US-PGPUB; USPAT; USOCR; FPRS; EPO; JPO; DERWENT; IBM_TDB	AND	ON	2011/03/17 12:44
S58	1	(digital same (watermark near5 signature)) and (@ad<"19960117")	US-PGPUB; USPAT; USOCR; FPRS; EPO; JPO; DERWENT; IBM_TDB	AND	ON	2011/03/17 12:44

S59	1	(watermark same (digital adj signature)) and (@ad<"19960117")	US-PGPUB; USPAT; USOCR; FPRS; EPO; JPO; DERWENT; IBM_TDB	AND	ON	2011/03/17 12:49
S60	12	((watermark or steganograph\$5) same ((software)) and (@ad<"19960117"))	US-PGPUB; USPAT; USOCR; FPRS; EPO; JPO; DERWENT; IBM_TDB	AND	ON	2011/03/17 12:56

EAST Search History (Interference)

< This search history is empty >

3/17/2011 2:02:38 PM

C:\Documents and Settings\ioeke\My Documents\EAST\Workspaces\11895388.wsp

Printed: November 19, 2010 (12:45pm)

Path: Y:\Clients\SCOT Scott A Moskowitz and Wistaria Trading, Inc\SCOT0014-4\Drafts\IDS_SCOT00014-4_11-19-2010.wpd

ATTORNEY DOCKET REFERENCE:

37 CFR 1.98(a)(1)(i) APPLICATION:

37 CFR 1.98(a)(1)(ii): THIS IS AN INFORMATION DISCLOSURE STATEMENT

LISTING OF UNITED STATES PATENTS - U series

EXAMINER INITIALS	REFERENCE NUMBER (U SERIES)	PATENT NUMBER	ISSUE DATE	NAME OF PATENTEE OR APPLICANT	PAGE/LINE AND FIGURE/ELEMENT OF RELEVANT MATERIAL AND/OR IDENTIFICATION OF PRIORITY APPLICATION IN WHICH REFERENCE IS CITED
	U 01	3947825	March 1976	Cassada	
	U 02	3984624	October 1976	Waggener	
	U 03	3986624	October 1976	Cates, Jr. et al.	
	U 04	4038596	July 1977	Lee	
	U 05	4200770	April 1980	Hellman et al.	
	U 06	4218582	August 1980	Hellman et al.	
	U 07	4339134	July 1982	Macheel	
	U 08	4390898	June 1983	Bond et al.	
	U 09	4405829	September 1983	Rivest et al.	
	U 010	4424414	January 1984	Hellman et al.	
	U 011	4528588	July 1985	Lofberg	
	U 012	4672605	June 1987	Hustig et al.	
	U 013	4748668	May 1988	Shamir et al.	
	U 014	4789928	December 1988	Fujisaki	
	U 015	4827508	May 1989	Shear	
	U 016	4876617	October 1989	Best et al.	
	U 017	4896275	January 1990	Jackson	

DATE: 03/17/2011	EXAMINER'S SIGNATURE: /Izunna Okeke/
------------------	--------------------------------------

ALL REFERENCES CONSIDERED EXCEPT WHERE LINED THROUGH. //I.O./

Printed: November 19, 2010 (12:45pm)

Path: Y:\Clients\SCOT Scott A Moskowitz and Wistaria Trading, Inc\SCOT0014-4\Drafts\IDS_SCOT00014-4_11-19-2010.wpd

37 CFR 1.98(a)(1)(i) APPLICATION:

37 CFR 1.98(a)(1)(iii): THIS IS AN INFORMATION DISCLOSURE STATEMENT

EXAMINER INITIALS	REFERENCE NUMBER (U SERIES)	PATENT NUMBER	ISSUE DATE	NAME OF PATENTEE OR APPLICANT	PAGE/LINE AND FIGURE/ELEMENT OF RELEVANT MATERIAL AND/OR IDENTIFICATION OF PRIORITY APPLICATION IN WHICH REFERENCE IS CITED
	U 018	4908873	March 1990	Philibert et al.	
	U 019	4939515	July 1990	Adelson	
	U 020	4969204	November 1990	Jones et al.	
	U 021	4972471	November 1990	Gross et al.	
	U 022	4977594	December 1990	Shear	
	U 023	4979210	December 1990	Nagata et al.	
	U 024	4980782	December 1990	Ginkel	
	U 025	5050213	September 1991	Shear	
	U 026	5073925	December 1991	Nagata et al.	
	U 027	5077665	December 1991	Silverman et al.	
	U 028	5113437	May 1992	Best et al.	
	U 029	5136581	August 1992	Muehrcke	
	U 030	5136646	August 1992	Haber et al.	
	U 031	5136647	August 1992	Haber et al.	
	U 032	5142576	August 1992	Nadan	
	U 033	5161210	November 1992	Druyvesteyn et al.	
	U 034	5210820	May 1993	Kenyon	
	U 035	5243423	September 1993	DeJean et al.	
	U 036	5243515	September 1993	Lee	
	U 037	5287407	February 1994	Holmes	
	U 038	5319735	June 1994	Preuss et al.	
DATE: 03/17/2011	EXAMINER'S SIGNATURE: /Izunna Okeke/				

ALL REFERENCES CONSIDERED EXCEPT WHERE LINED THROUGH. //I.O./

Printed: November 19, 2010 (12:45pm)

Path: Y:\Clients\SCOT Scott A Moskowitz and Wistaria Trading, Inc\SCOT0014-4\Drafts\IDS_SCOT00014-4_11-19-2010.wpd

37 CFR 1.98(a)(1)(i) APPLICATION:

37 CFR 1.98(a)(1)(iii): THIS IS AN INFORMATION DISCLOSURE STATEMENT

EXAMINER INITIALS	REFERENCE NUMBER (U SERIES)	PATENT NUMBER	ISSUE DATE	NAME OF PATENTEE OR APPLICANT	PAGE/LINE AND FIGURE/ELEMENT OF RELEVANT MATERIAL AND/OR IDENTIFICATION OF PRIORITY APPLICATION IN WHICH REFERENCE IS CITED
	U 039	5341429	August 1994	Stringer et al.	
	U 040	5341477	August 1994	Pitkin et al.	
	U 041	5363448	November 1994	Koopman et al.	
	U 042	5365586	November 1994	Indeck et al.	
	U 043	5369707	November 1994	Follendore, III	
	U 044	5379345	January 1995	Greenberg	
	U 045	5394324	February 1995	Clearwater	
	U 046	5398285	March 1995	Borgelt et al.	
	U 047	5406627	April 1995	Thompson et al.	
	U 048	5408505	April 1995	Indeck et al.	
	U 049	5410598	April 1995	Shear	
	U 050	5412718	May 1995	Narasimhalv et al.	
	U 051	5418713	May 1995	Allen	
	U 052	5428606	June 1995	Moskowitz	
	U 053	5450490	September 1995	Jensen et al.	
	U 054	5469536	November 1995	Blank	
	U 055	5471533	November 1995	Wang et al.	
	U 056	5478990	December 1995	Montanari et al.	
	U 057	5479210	December 1995	Cawley et al.	
	U 058	5487168	January 1996	Geiner et al.	
	U 059	5493677	February 1996	Balogh et al.	

DATE: 03/17/2011	EXAMINER'S SIGNATURE: /Izunna Okeke/
------------------	--------------------------------------

ALL REFERENCES CONSIDERED EXCEPT WHERE LINED THROUGH. //I.O./

Printed: November 19, 2010 (12:45pm)

Path: Y:\Clients\SCOT Scott A Moskowitz and Wistaria Trading, Inc\SCOT0014-4\Drafts\IDS_SCOT00014-4_11-19-2010.wpd

37 CFR 1.98(a)(1)(i) APPLICATION:

37 CFR 1.98(a)(1)(iii): THIS IS AN INFORMATION DISCLOSURE STATEMENT

EXAMINER INITIALS	REFERENCE NUMBER (U SERIES)	PATENT NUMBER	ISSUE DATE	NAME OF PATENTEE OR APPLICANT	PAGE/LINE AND FIGURE/ELEMENT OF RELEVANT MATERIAL AND/OR IDENTIFICATION OF PRIORITY APPLICATION IN WHICH REFERENCE IS CITED
	U 060	5497419	March 1996	Hill	
	U 061	5506795	April 1996	Yamakawa	
	U 062	5513126	April 1996	Harkins et al.	
	U 063	5513261	April 1996	Maher	
	U 064	5530739	June 1996	Okada	
	U 065	5530751	June 1996	Morris	
	U 066	5530759	June 1996	Braudaway et al.	
	U 067	5539735	July 1996	Moskowitz	
	U 068	5548579	August 1996	Lebrun et al.	
	U 069	5568570	October 1996	Rabbani	
	U 070	5579124	November 1996	Ajjala et al.	
	U 071	5581703	December 1996	Baugher et al.	
	U 072	5583488	December 1996	Sala et al.	
	U 073	5598470	January 1997	Cooper et al.	
	U 074	5606609	February 1997	Houser et al.	
	U 075	5613004	March 1997	Cooperman et al.	
	U 076	5617119	April 1997	Briggs et al.	
	U 077	5625690	April 1997	Michel et al.	
	U 078	5629980	May 1997	Stefik et al.	
	U 079	5633932	May 1997	Davis et al.	
	U 080	5634040	May 1997	Her et al.	

DATE: 03/17/2011	EXAMINER'S SIGNATURE: /Izunna Okeke/
------------------	--------------------------------------

ALL REFERENCES CONSIDERED EXCEPT WHERE LINED THROUGH. //I.O./

Printed: November 19, 2010 (12:45pm)

Path: Y:\Clients\SCOT Scott A Moskowitz and Wistaria Trading, Inc\SCOT0014-4\Drafts\IDS_SCOT00014-4_11-19-2010.wpd

37 CFR 1.98(a)(1)(i) APPLICATION:

37 CFR 1.98(a)(1)(iii): THIS IS AN INFORMATION DISCLOSURE STATEMENT

EXAMINER INITIALS	REFERENCE NUMBER (U SERIES)	PATENT NUMBER	ISSUE DATE	NAME OF PATENTEE OR APPLICANT	PAGE/LINE AND FIGURE/ELEMENT OF RELEVANT MATERIAL AND/OR IDENTIFICATION OF PRIORITY APPLICATION IN WHICH REFERENCE IS CITED
	U 081	5636276	June 1997	Brugger	
	U 082	5636292	June 1997	Rhoads	
	U 083	5640569	June 1997	Miller et al.	
	U 084	5646997	July 1997	Barton	
	U 085	5657461	August 1997	Harkins et al.	
	U 086	5659726	August 1997	Sandford, II et al.	
	U 087	5664018	September 1997	Leighton	
	U 088	5673316	September 1997	Auerbach et al.	
	U 089	5677952	October 1997	Blakely et al.	
	U 090	5680462	October 1997	Miller et al.	
	U 091	5687236	November 1997	Moskowitz et al.	
	U 092	5689587	November 1997	Bender et al.	
	U 093	5696828	December 1997	Koopman, Jr.	
	U 094	5719937	February 1998	Warren et al.	
	U 095	5721788	February 1998	Powell et al.	
	U 096	5734752	March 1998	Knox	
	U 097	5737416	April 1998	Cooper et al.	
	U 098	5737733	April 1998	Eller	
	U 099	5740244	April 1998	Indeck et al.	
	U 0100	5745569	April 1998	Moskowitz et al.	
	U 0101	5748783	May 1998	Rhoads	

DATE: 03/17/2011	EXAMINER'S SIGNATURE: /Izunna Okeke/
------------------	--------------------------------------

ALL REFERENCES CONSIDERED EXCEPT WHERE LINED THROUGH. //I.O./

Printed: November 19, 2010 (12:45pm)

Path: Y:\Clients\SCOT Scott A Moskowitz and Wistaria Trading, Inc\SCOT0014-4\Drafts\IDS_SCOT00014-4_11-19-2010.wpd

37 CFR 1.98(a)(1)(i) APPLICATION:

37 CFR 1.98(a)(1)(iii): THIS IS AN INFORMATION DISCLOSURE STATEMENT

EXAMINER INITIALS	REFERENCE NUMBER (U SERIES)	PATENT NUMBER	ISSUE DATE	NAME OF PATENTEE OR APPLICANT	PAGE/LINE AND FIGURE/ELEMENT OF RELEVANT MATERIAL AND/OR IDENTIFICATION OF PRIORITY APPLICATION IN WHICH REFERENCE IS CITED
	U 0102	5751811	May 1998	Magnotti et al.	
	U 0103	5754697	May 1998	Fu et al.	
	U 0104	5757923	May 1998	Koopman, Jr.	
	U 0105	5765152	June 1998	Erickson	
	U 0106	5768396	June 1998	Sone	
	U 0107	5774452	June 1998	Wolosewicz	
	U 0108	5790677	August 1998	Fox et al.	
	U 0109	5799083	August 1998	Brothers et al.	
	U 0110	5809139	September 1998	Grirod et al.	
	U 0111	5809160	September 1998	Powell et al.	
	U 0112	5822432	October 1998	Moskowitz et al.	
	U 0113	5828325	October 1998	Wolosewicz et al.	
	U 0114	5832119.	November 1998	Rhoads	
	U 0115	5848155	December 1998	Cox	
	U 0116	5850481	December 1998	Rhoads	
	U 0117	5859920	January 1999	Daly et al.	
	U 0118	5860099	January 1999	Milios et al.	
	U 0119	5862260	January 1999	Rhoads	
	U 0120	5870474	February 1999	Wasilewski et al.	
	U 0121	5884033	March 1999	Duvall et al.	
	U 0122	5889868	March 1999	Moskowitz et al.	

DATE: 03/17/2011	EXAMINER'S SIGNATURE: /Izunna Okeke/
------------------	--------------------------------------

ALL REFERENCES CONSIDERED EXCEPT WHERE LINED THROUGH. //I.O./

Printed: November 19, 2010 (12:45pm)

Path: Y:\Clients\SCOT Scott A Moskowitz and Wistaria Trading, Inc\SCOT0014-4\Drafts\IDS_SCOT00014-4_11-19-2010.wpd

37 CFR 1.98(a)(1)(i) APPLICATION:

37 CFR 1.98(a)(1)(iii): THIS IS AN INFORMATION DISCLOSURE STATEMENT

EXAMINER INITIALS	REFERENCE NUMBER (U SERIES)	PATENT NUMBER	ISSUE DATE	NAME OF PATENTEE OR APPLICANT	PAGE/LINE AND FIGURE/ELEMENT OF RELEVANT MATERIAL AND/OR IDENTIFICATION OF PRIORITY APPLICATION IN WHICH REFERENCE IS CITED
	U 0123	5893067	April 1999	Bender et al.	
	U 0124	5894521	April 1999	Conley	
	U 0125	5903721	May 1999	Sixtus	
	U 0126	5905800	May 1999	Moskowitz et al.	
	U 0127	5905975	May 1999	Ausubel	
	U 0128	5912972	June 1999	Barton	
	U 0129	5915027	June 1999	Cox et al.	
	U 0130	5917915	June 1999	Hirose	
	U 0131	5918223	June 1999	Blum	
	U 0132	5920900	July 1999	Poole et al.	
	U 0133	5923763	July 1999	Walker et al.	
	U 0134	5930369	July 1999	Cox et al.	
	U 0135	5930377	July 1999	Powell et al	
	U 0136	5940134	August 1999	Wirtz	
	U 0137	5943422	August 1999	Van Wie et al.	
	U 0138	5963909	October 1999	Warren et al.	
	U 0139	5973731	October 1999	Schwab	
	U 0140	5974141	October 1999	Saito	
	U 0141	5991426	November 1999	Cox et al.	
	U 0142	5999217	December 1999	Berners-Lee	
	U 0143	6009176	December 1999	Gennaro et al.	

DATE: 03/17/2011	EXAMINER'S SIGNATURE: /Izunna Okeke/
------------------	--------------------------------------

ALL REFERENCES CONSIDERED EXCEPT WHERE LINED THROUGH. //I.O./

Printed: November 19, 2010 (12:45pm)

Path: Y:\Clients\SCOT Scott A Moskowitz and Wistaria Trading, Inc\SCOT0014-4\Drafts\IDS_SCOT00014-4_11-19-2010.wpd

37 CFR 1.98(a)(1)(i) APPLICATION:

37 CFR 1.98(a)(1)(iii): THIS IS AN INFORMATION DISCLOSURE STATEMENT

EXAMINER INITIALS	REFERENCE NUMBER (U SERIES)	PATENT NUMBER	ISSUE DATE	NAME OF PATENTEE OR APPLICANT	PAGE/LINE AND FIGURE/ELEMENT OF RELEVANT MATERIAL AND/OR IDENTIFICATION OF PRIORITY APPLICATION IN WHICH REFERENCE IS CITED
	U 0144	6029126	February 2000	Malvar	
	U 0145	6041316	March 2000	Allen	
	U 0146	6044471	March 2000	Colvin	
	U 0147	6049838	April 2000	Miller et al.	
	U 0148	6051029	April 2000	Paterson et al.	
	U 0149	6061793	May 2000	Tewfik et al.	
	U 0150	6069914	May 2000	Cox	
	U 0151	6078664	June 2000	Moskowitz et al.	
	U 0152	6081251	June 2000	Sakai et al.	
	U 0153	6081587	June 2000	Reyes et al.	
	U 0154	6088455	July 2000	Logan et al.	
	U 0155	6131162	October 2000	Yoshiura et al.	
	U 0156	6141753	October 2000	Zhao et al.	
	U 0157	6141754	October 2000	Choy	
	U 0158	6154571	November 2000	Cox et al.	
	U 0159	6192138	February 2001	Yamadaji	
	U 0160	6199058	March 2001	Wong et al.	
	U 0161	6205249	March 2001	Moskowitz	
	U 0162	6208745	March 2001	Florenio et al.	
	U 0163	6230268	May 2001	Miwa et al.	
	U 0164	6233347	May 2001	Chen et al.	

DATE: 03/17/2011	EXAMINER'S SIGNATURE: /Izunna Okeke/
------------------	--------------------------------------

ALL REFERENCES CONSIDERED EXCEPT WHERE LINED THROUGH. //I.O./

Printed: November 19, 2010 (12:45pm)

Path: Y:\Clients\SCOT Scott A Moskowitz and Wistaria Trading, Inc\SCOT0014-4\Drafts\IDS_SCOT00014-4_11-19-2010.wpd

37 CFR 1.98(a)(1)(i) APPLICATION:

37 CFR 1.98(a)(1)(iii): THIS IS AN INFORMATION DISCLOSURE STATEMENT

EXAMINER INITIALS	REFERENCE NUMBER (U SERIES)	PATENT NUMBER	ISSUE DATE	NAME OF PATENTEE OR APPLICANT	PAGE/LINE AND FIGURE/ELEMENT OF RELEVANT MATERIAL AND/OR IDENTIFICATION OF PRIORITY APPLICATION IN WHICH REFERENCE IS CITED
	U 0165	6233684	May 2001	Stefik et al.	
	U 0166	6240121	May 2001	Senoh	
	U 0167	6263313	July 2001	Milstead et al.	
	U 0168	6272634	August 2001	Tewfik et al.	
	U 0169	6275988	August 2001	Nagashima et al.	
	U 0170	6278780	August 2001	Shimada	
	U 0171	6278791	August 2001	Honsinger et al.	
	U 0172	6282300	August 2001	Bloom et al.	
	U 0173	6282650	August 2001	Davis	
	U 0174	6285775	September 2001	Wu et al.	
	U 0175	6301663	October 2001	Kato et al.	
	U 0176	6310962	October 2001	Chung et al.	
	U 0177	6330335	December 2001	Rhoads	
	U 0178	6330672	December 2001	Shur	
	U 0179	6345100	February 2002	Levine	
	U 0180	6351765	February 2002	Pietropaolo et al.	
	U 0181	6363483	March 2002	Keshav	
	U 0182	6373892	April 2002	Ichien et al.	
	U 0183	6373960	April 2002	Conover et al.	
	U 0184	6374036	April 2002	Ryan et al.	
	U 0185	6377625	April 2002	Kim	

DATE: 03/17/2011	EXAMINER'S SIGNATURE: /Izunna Okeke/
------------------	--------------------------------------

ALL REFERENCES CONSIDERED EXCEPT WHERE LINED THROUGH. //I.O./

Printed: November 19, 2010 (12:45pm)

Path: Y:\Clients\SCOT Scott A Moskowitz and Wistaria Trading, Inc\SCOT0014-4\Drafts\IDS_SCOT00014-4_11-19-2010.wpd

37 CFR 1.98(a)(1)(i) APPLICATION:

37 CFR 1.98(a)(1)(iii): THIS IS AN INFORMATION DISCLOSURE STATEMENT

EXAMINER INITIALS	REFERENCE NUMBER (U SERIES)	PATENT NUMBER	ISSUE DATE	NAME OF PATENTEE OR APPLICANT	PAGE/LINE AND FIGURE/ELEMENT OF RELEVANT MATERIAL AND/OR IDENTIFICATION OF PRIORITY APPLICATION IN WHICH REFERENCE IS CITED
	U 0186	6381618	April 2002	Jones et al.	
	U 0187	6381747	April 2002	Wonfor et al.	
	U 0188	6385329	May 2002	Sharma et al.	
	U 0189	6389538	May 2002	Gruse et al.	
	U 0190	6405203	June 2002	Collart	
	U 0191	6415041	July 2002	Oami et al.	
	U 0192	6425081	July 2002	Iwamura	
	U 0193	6430301	August 2002	Petrovic	
	U 0194	6430302	August 2002	Rhoads	
	U 0195	6442283	August 2002	Tewfik et al.	
	U 0196	6446211	September 2002	Colvin	
	U 0197	6453252	September 2002	Laroche	
	U 0198	6457058	September 2002	Ullum et al.	
	U 0199	6463468	October 2002	Buch et al.	
	U 0200	6484264	November 2002	Colvin	
	U 0201	6493457	December 2002	Quackenbush	
	U 0202	6502195	December 2002	Colvin	
	U 0203	6522767	February 2003	Moskowitz et al.	
	U 0204	6522769	February 2003	Rhoads et al.	
	U 0205	6523113	February 2003	Wehrenberg	
	U 0206	6530021	March 2003	Epstein et al.	

DATE: 03/17/2011	EXAMINER'S SIGNATURE: /Izunna Okeke/
------------------	--------------------------------------

ALL REFERENCES CONSIDERED EXCEPT WHERE LINED THROUGH. //I.O./

Printed: November 19, 2010 (12:45pm)

Path: Y:\Clients\SCOT Scott A Moskowitz and Wistaria Trading, Inc\SCOT0014-4\Drafts\IDS_SCOT00014-4_11-19-2010.wpd

37 CFR 1.98(a)(1)(i) APPLICATION:

37 CFR 1.98(a)(1)(iii): THIS IS AN INFORMATION DISCLOSURE STATEMENT

EXAMINER INITIALS	REFERENCE NUMBER (U SERIES)	PATENT NUMBER	ISSUE DATE	NAME OF PATENTEE OR APPLICANT	PAGE/LINE AND FIGURE/ELEMENT OF RELEVANT MATERIAL AND/OR IDENTIFICATION OF PRIORITY APPLICATION IN WHICH REFERENCE IS CITED
	U 0207	6532284	March 2003	Walker et al.	
	U 0208	6539475	March 2003	Cox et al.	
	U 0209	6557103	April 2003	Boncelet, Jr. et al.	
	U 0210	6584125	June 2003	Katto	
	U 0211	6587837	July 2003	Spagna et al.	
	U 0212	6598162	July 2003	Moskowitz	
	U 0213	6606393	August 2003	Xie et al.	
	U 0214	6647424	November 2003	Pearson et al.	
	U 0215	6658010	December 2003	Enns et al.	
	U 0216	6665489	December 2003	Collart	
	U 0217	6668246	December 2003	Yeung et al.	
	U 0218	6668325	December 2003	Collberg et al	.
	U 0219	6687683	February 2004	Harada et al.	
	U 0220	6725372	April 2004	Lewis et al	.
	U 0221	6754822	June 2004	Zhao	
	U 0222	6775772	August 2004	Binding et al.	
	U 0223	6784354	August 2004	Lu et al.	
	U 0224	6785815	August 2004	Serret-Avila et al.	
	U 0225	6785825	August 2004	Colvin	
	U 0226	6792548	September 2004	Colvin	
	U 0227	6792549	September 2004	Colvin	

DATE: 03/17/2011	EXAMINER'S SIGNATURE: /Izunna Okeke/
------------------	--------------------------------------

ALL REFERENCES CONSIDERED EXCEPT WHERE LINED THROUGH. //I.O./

Printed: November 19, 2010 (12:45pm)

Path: Y:\Clients\SCOT Scott A Moskowitz and Wistaria Trading, Inc\SCOT0014-4\Drafts\IDS_SCOT00014-4_11-19-2010.wpd

37 CFR 1.98(a)(1)(i) APPLICATION:

37 CFR 1.98(a)(1)(iii): THIS IS AN INFORMATION DISCLOSURE STATEMENT

EXAMINER INITIALS	REFERENCE NUMBER (U SERIES)	PATENT NUMBER	ISSUE DATE	NAME OF PATENTEE OR APPLICANT	PAGE/LINE AND FIGURE/ELEMENT OF RELEVANT MATERIAL AND/OR IDENTIFICATION OF PRIORITY APPLICATION IN WHICH REFERENCE IS CITED
	U 0228	6795925	September 2004	Colvin	
	U 0229	6799277	September 2004	Colvin	
	U 0230	6813717	November 2004	Colvin	
	U 0231	6813718	November 2004	Colvin	
	U 0232	6823455	November 2004	Macy et al.	
	U 0233	6834308	December 2004	Ikezoye et al.	
	U 0234	6842862	January 2005	Chow et al.	
	U 0235	6853726	February 2005	Moskowitz et al.	
	U 0236	6857078	February 2005	Colvin	
	U 0237	6931534	August 2005	Jandel et al.	
	U 0238	6966002	November 2005	Torrubia-Saez	
	U 0239	6983337	November 2005	Wold	
	U 0240	6977894	December 2005	Achilles et al.	
	U 0241	6978370	December 2005	Kocher	
	U 0242	6986063	January 2006	Colvin	
	U 0243	7007166	February 2006	Moskowitz et al.	
	U 0244	7020285	March 2006	Kirovski et al.	
	U 0245	7035409	April 2006	Moskowitz	
	U 0246	7043050	May 2006	Yuval	
	U 0247	7046808	May 2006	Metois et al.	
	U 0248	7050396	May 2006	Cohen et al.	

DATE: 03/17/2011	EXAMINER'S SIGNATURE: /Izunna Okeke/
------------------	--------------------------------------

ALL REFERENCES CONSIDERED EXCEPT WHERE LINED THROUGH. //I.O./

Printed: November 19, 2010 (12:45pm)

Path: Y:\Clients\SCOT Scott A Moskowitz and Wistaria Trading, Inc\SCOT0014-4\Drafts\IDS_SCOT00014-4_11-19-2010.wpd

37 CFR 1.98(a)(1)(i) APPLICATION:

37 CFR 1.98(a)(1)(iii): THIS IS AN INFORMATION DISCLOSURE STATEMENT

EXAMINER INITIALS	REFERENCE NUMBER (U SERIES)	PATENT NUMBER	ISSUE DATE	NAME OF PATENTEE OR APPLICANT	PAGE/LINE AND FIGURE/ELEMENT OF RELEVANT MATERIAL AND/OR IDENTIFICATION OF PRIORITY APPLICATION IN WHICH REFERENCE IS CITED
	U 0249	7051208	May 2006	Venkatesan et al.	
	U 0250	7058570	June 2006	Yu et al.	
	U 0251	7093295	August 2006	Saito	
	U 0252	7095874	August 2006	Moskowitz et al	.
	U 0253	7103184	September 2006	Jian	
	U 0254	7107451	September 2006	Moskowitz	
	U 0255	7123718	October 2006	Moskowitz et al.	
	U 0256	7127615	October 2006	Moskowitz	
	U 0257	7150003	December 2006	Naumovich et al.	
	U 0258	7152162	December 2006	Moskowitz et al.	
	U 0259	7159116	January 2007	Moskowitz	
	U 0260	7162642	January 2007	Schumann et al.	
	U 0261	7177429	February 2007	Moskowitz et al.	
	U 0262	7177430	February 2007	Kim	
	U 0263	7206649	April 2007	Kirovski et al.	
	U 0264	7231524	June 2007	Bums	
	U 0265	7233669.	June 2007	Candelore	
	U 0266	7240210	July 2007	Michak et al.	
	U 0267	7266697	September 2007	Kirovski et al	.
	U 0268	7287275	October 2007	Moskowitz	
	U 0269	7289643	October 2007	Brunk et al.	

DATE: 03/17/2011	EXAMINER'S SIGNATURE: /Izunna Okeke/
------------------	--------------------------------------

ALL REFERENCES CONSIDERED EXCEPT WHERE LINED THROUGH. //I.O./

Printed: November 19, 2010 (12:45pm)

Path: Y:\Clients\SCOT Scott A Moskowitz and Wistaria Trading, Inc\SCOT0014-4\Drafts\IDS_SCOT00014-4_11-19-2010.wpd

37 CFR 1.98(a)(1)(i) APPLICATION:

37 CFR 1.98(a)(1)(iii): THIS IS AN INFORMATION DISCLOSURE STATEMENT

EXAMINER INITIALS	REFERENCE NUMBER (U SERIES)	PATENT NUMBER	ISSUE DATE	NAME OF PATENTEE OR APPLICANT	PAGE/LINE AND FIGURE/ELEMENT OF RELEVANT MATERIAL AND/OR IDENTIFICATION OF PRIORITY APPLICATION IN WHICH REFERENCE IS CITED
	U 0270	7343492	March 2008	Moskowitz et al.	
	U 0271	7346472	March 2008	Moskowitz et al.	
	U 0272	7362775	April 2008	Moskowitz	
	U 0273	7363278	April 2008	Schmelzer et al.	
	U 0274	7409073	August 2008	Moskowitz et al.	
	U 0275	7457962	November 2008	Moskowitz	
	U 0276	7460994	December 2008	Herre et al.	
	U 0277	7475246	January 2009	Moskowitz	
	U 0278	7530102	May 2009	Moskowitz	
	U 0279	7532725	May 2009	Moskowitz et al.	
	U 0280	7568100	July 2009	Moskowitz et al.	
	U 0281	7647502	January 2010	Moskowitz	
	U 0282	7647503	January 2010	Moskowitz	
	U 0283	7779261	August 2010	Moskowitz	
	U 0284	6990453	January 2006	Wang	
	U 0285	6081597	June 2000	Hoffstein	
	U 0286	7035049	Apr 2006	Yamamoto	
	U 0287	7664263	Feb 2010	Moskowitz	
	U 0288	7286451	Oct 2007	Wirtz	
	U 0289	6385324	May 2002	Koppen	
	U 0290	6674858	Jan 2004	Kimura	

DATE: 03/17/2011	EXAMINER'S SIGNATURE: /Izunna Okeke/
------------------	--------------------------------------

ALL REFERENCES CONSIDERED EXCEPT WHERE LINED THROUGH. //I.O./

Printed: November 19, 2010 (12:45pm)

Path: Y:\Clients\SCOT Scott A Moskowitz and Wistaria Trading, Inc\SCOT0014-4\Drafts\IDS_SCOT00014-4_11-19-2010.wpd

37 CFR 1.98(a)(1)(i) APPLICATION:

37 CFR 1.98(a)(1)(iii): THIS IS AN INFORMATION DISCLOSURE STATEMENT

EXAMINER INITIALS	REFERENCE NUMBER (U SERIES)	PATENT NUMBER	ISSUE DATE	NAME OF PATENTEE OR APPLICANT	PAGE/LINE AND FIGURE/ELEMENT OF RELEVANT MATERIAL AND/OR IDENTIFICATION OF PRIORITY APPLICATION IN WHICH REFERENCE IS CITED
	U 0291	6148333	Nov 2000	Guedalia	
	U 0292	6418421	Jun 2002	Hurtado	
	U 0293	6385596	May 2002	Wiser	
	U 0294	6226618	May 2001	Downs	
	U 0295	6957330	Oct 2005	Hughes	
	U 0296	5842213	Nov 1998	Odom	
	U 0297	5818818	Oct 1998	Soumiya	
	U 0298	6590996	Jun 2003	Reed	
	U 0299	5949055	Sept 1999	Fleet	
	U 0300	6067622	May 2000	Moore	
	U 0301	7761712	Jun 2010	Moskowitz	
	U 0302	7743001	Jun 2010	Vermeulen	

DATE: 03/17/2011	EXAMINER'S SIGNATURE: /Izunna Okeke/
------------------	--------------------------------------

ALL REFERENCES CONSIDERED EXCEPT WHERE LINED THROUGH. //I.O./

Printed: November 19, 2010 (12:45pm)

Path: Y:\Clients\SCOT Scott A Moskowitz and Wistaria Trading, Inc\SCOT0014-4\Drafts\IDS_SCOT00014-4_11-19-2010.wpd

37 CFR 1.98(a)(1)(i) APPLICATION:

37 CFR 1.98(a)(1)(iii): THIS IS AN INFORMATION DISCLOSURE STATEMENT

LISTING OF UNITED STATES PUBLISHED APPLICATIONS - P Series

EXAMINER INITIALS	REFERENCE NUMBER (P SERIES)	PUBLICATION NUMBER	PUBLICATION DATE	NAME OF PATENTEE OR APPLICANT	PAGE/LINE AND FIGURE/ELEMENT OF RELEVANT MATERIAL AND/OR IDENTIFICATION OF PRIORITY APPLICATION IN WHICH REFERENCE CITED
	P 01	20010010078	July 2001	Moskowitz	
	P 02	20010043594	November 2001	Ogawa et al.	
	P 03	20020010684	January 2002	Moskowitz	
	P 04	20020026343	February 2002	Duenke	
	P 05	20020056041	May 2002	Moskowitz	
	P 06	20020071556	June 2002	Moskowitz et al.	
	P 07	20020073043	June 2002	Herman et al.	
	P 08	20020097873	July 2002	Petrovic	
	P 09	20020103883	August 2002	Haverstock et al.	
	P 010	20020161741	October 2002	Wang et al.	
	P 011	20030126445	July 2003	Wehrenberg	
	P 012	20030133702	July 2003	Collart	
	P 013	20030200439	October 2003	Moskowitz	
	P 014	20030219143	November 2003	Moskowitz et al.	
	P 015	20040028222	February 2004	Sewell et al.	
	P 016	20040037449	February 2004	Davis et al.	
	P 017	20040049695	March 2004	Choi et al.	
	P 018	20040059918	March 2004	Xu	
	P 019	20040083369	April 2004	Erlingsson et al.	
	P 020	20040086119	May 2004	Moskowitz	
	P 021	20040093521	May 2004	Hamadeh et al.	

DATE: 03/17/2011	EXAMINER'S SIGNATURE: /Izunna Okeke/
------------------	--------------------------------------

ALL REFERENCES CONSIDERED EXCEPT WHERE LINED THROUGH. //I.O./

Printed: November 19, 2010 (12:45pm)

Path: Y:\Clients\SCOT Scott A Moskowitz and Wistaria Trading, Inc\SCOT0014-4\Drafts\IDS_SCOT00014-4_11-19-2010.wpd

37 CFR 1.98(a)(1)(i) APPLICATION:

37 CFR 1.98(a)(1)(iii): THIS IS AN INFORMATION DISCLOSURE STATEMENT

EXAMINER INITIALS	REFERENCE NUMBER (P SERIES)	PUBLICATION NUMBER	PUBLICATION DATE	NAME OF PATENTEE OR APPLICANT	PAGE/LINE AND FIGURE/ELEMENT OF RELEVANT MATERIAL AND/OR IDENTIFICATION OF PRIORITY APPLICATION IN WHICH REFERENCE CITED
	P 022	20040117628	June 2004	Colvin	
	P 023	20040117664	June 2004	Colvin	
	P 024	20040125983	July 2004	Reed et al.	
	P 025	20040128514.	July 2004	Rhoads	
	P 026	20040225894	November 2004	Colvin	
	P 027	20040243540	December 2004	Moskowitz et al.	
	P 028	20050135615	June 2005	Moskowitz et al.	
	P 029	20050160271	July 2005	Brundage et al.	
	P 030	20050177727	August 2005	Moskowitz et al.	
	P 031	20050246554	November 2005	Batson	
	P 032	20060005029	January 2006	Petrovic et al.	
	P 033	20060013395	January 2006	Brundage et al.	
	P 034	20060013451	January 2006	Haitsma	
	P 035	20060041753	February 2006	Haitsma	
	P 036	20060101269	May 2006	Moskowitz et al.	
	P 037	20060140403	June 2006	Moskowitz	
	P 038	20060285722	December 2006	Moskowitz et al.	
	P 039	20070011458	January 2007	Moskowitz	
	P 040	20070028113	February 2007	Moskowitz	
	P 041	20070064940	March 2007	Moskowitz et al.	
	P 042	20070079131.	April 2007	Moskowitz et al.	

DATE: 03/17/2011	EXAMINER'S SIGNATURE: /Izunna Okeke/
------------------	--------------------------------------

ALL REFERENCES CONSIDERED EXCEPT WHERE LINED THROUGH. //I.O./

Printed: November 19, 2010 (12:45pm)

Path: Y:\Clients\SCOT Scott A Moskowitz and Wistaria Trading, Inc\SCOT0014-4\Drafts\IDS_SCOT00014-4_11-19-2010.wpd

37 CFR 1.98(a)(1)(i) APPLICATION:

37 CFR 1.98(a)(1)(iii): THIS IS AN INFORMATION DISCLOSURE STATEMENT

EXAMINER INITIALS	REFERENCE NUMBER (P SERIES)	PUBLICATION NUMBER	PUBLICATION DATE	NAME OF PATENTEE OR APPLICANT	PAGE/LINE AND FIGURE/ELEMENT OF RELEVANT MATERIAL AND/OR IDENTIFICATION OF PRIORITY APPLICATION IN WHICH REFERENCE CITED
	P 043	20070083467	April 2007	Lindahl et al.	
	P 044	20070110240	May 2007	Moskowitz et al.	
	P 045	20070113094	May 2007	Moskowitz et al.	
	P 046	20070127717	June 2007	Herre et al.	
	P 047	20070226506	September 2007	Moskowitz	
	P 048	20070253594	November 2007	Lu et al.	
	P 049	20070294536	December 2007	Moskowitz et al.	
	P 050	20070300072	December 2007	Moskowitz	
	P 051	20070300073	December 2007	Moskowitz	
	P 052	20080005571	January 2008	Moskowitz	
	P 053	20080005572	January 2008	Moskowitz	
	P 054	20080016365	January 2008	Moskowitz	
	P 055	20080022113	January 2008	Moskowitz	
	P 056	20080022114	January 2008	Moskowitz	
	P 057	20080028222	January 2008	Moskowitz	
	P 058	20080046742	February 2008	Moskowitz	
	P 059	20080075277	March 2008	Moskowitz et al.	
	P 060	20080109417	May 2008	Moskowitz	
	P 061	20080133927	June 2008	Moskowitz et al.	
	P 062	20080151934	June 2008	Moskowitz et al.	
	P 063	20090037740	February 2009	Moskowitz	

DATE: 03/17/2011	EXAMINER'S SIGNATURE: /Izunna Okeke/
------------------	--------------------------------------

ALL REFERENCES CONSIDERED EXCEPT WHERE LINED THROUGH. //I.O./

Printed: November 19, 2010 (12:45pm)

Path: Y:\Clients\SCOT Scott A Moskowitz and Wistaria Trading, Inc\SCOT0014-4\Drafts\IDS_SCOT00014-4_11-19-2010.wpd

37 CFR 1.98(a)(1)(i) APPLICATION:

37 CFR 1.98(a)(1)(iii): THIS IS AN INFORMATION DISCLOSURE STATEMENT

EXAMINER INITIALS	REFERENCE NUMBER (P SERIES)	PUBLICATION NUMBER	PUBLICATION DATE	NAME OF PATENTEE OR APPLICANT	PAGE/LINE AND FIGURE/ELEMENT OF RELEVANT MATERIAL AND/OR IDENTIFICATION OF PRIORITY APPLICATION IN WHICH REFERENCE CITED
	P 064	20090089427	April 2009	Moskowitz et al.	
	P 065	20090190754	July 2009	Moskowitz et al.	
	P 066	20090210711	August 2009	Moskowitz	
	P 067	20090220074	September 2009	Moskowitz et al.	
	P 068	20100002904	January 2010	Moskowitz	
	P 069	20100005308	January 2010	Moskowitz	
	P 070	20100098251	Apr 2010	Moskowitz	
	P 071	20100220861	Sept 2010	Moskowitz	
	P 072	20100202607	Aug 2010	Moskowitz	
	P 073	20020047873	June 2002	Petrovic	
	P 074	20020009208	Jan 2002	Alattar	
	P 075	20010029580	October 2001	Moskowitz	
	P 076	20100182570	July 2010	Chota	
	P 077	20100077220	March 2010	Moskowitz	
	P 078	20100077219	March 2010	Moskowitz	
	P 079	20100064140	March 2010	Moskowitz	
	P 080	20100153734	June 2010	Moskowitz	
	P 081	20100106736	April 2010	Moskowitz	
	P 082	20060251291	November 2006	Rhoads	

DATE: 03/17/2011	EXAMINER'S SIGNATURE: /Izunna Okeke/
------------------	--------------------------------------

ALL REFERENCES CONSIDERED EXCEPT WHERE LINED THROUGH. //I.O./

Printed: November 19, 2010 (12:45pm)

Path: Y:\Clients\SCOT Scott A Moskowitz and Wistaria Trading, Inc\SCOT0014-4\Drafts\IDS_SCOT00014-4_11-19-2010.wpd

37 CFR 1.98(a)(1)(i) APPLICATION:

37 CFR 1.98(a)(1)(iii): THIS IS AN INFORMATION DISCLOSURE STATEMENT

LISTING OF FOREIGN AND INTERNATIONAL PATENT DOCUMENTS - F Series

EXAMINER INITIALS	REFERENCE NUMBER (F SERIES)	PUBLICATION NUMBER	PUBLICATION DATE	COUNTRY OR REGION	PAGE/LINE AND FIGURE/ELEMENT OF RELEVANT MATERIAL	ENGLISH LANGUAGE TRANSLATION ATTACHED? (YES OR NO) AND/OR IDENTIFICATION OF PRIORITY APPLICATION IN WHICH REFERENCE IS CITED
	F 01-	EP0372601	Jun., 1990	EP		
	F 02-	EP0565947	Oct., 1993	EP		
	F 03-	EP0581317	Feb., 1994	EP		
	F 04-	EP0649261	Apr., 1995	EP		
	F 05-	EP0651554	May., 1995	EP		
	F 06-	EP1354276	Dec., 2007	EP		
	F 07-	NL 1005523	Sep., 1998	NL		
	F 08-	WO 9514289	May., 1995	WO		
	F 09-	WO 9629795	Sep., 1996	WO		
	F 010-	WO 9724833	Jul., 1997	WO		
	F 011-	WO 9744736	Nov., 1997	WO		
	F 012-	WO9837513	Aug., 1998	WO		
	F 013-	WO 9952271	Oct., 1999	WO		
	F 014-	WO 9962044	Dec., 1999	WO		
	F 015-	WO 9963443	Dec., 1999	WO		
	F 016-	WO9726733	Jan. 1997	WO		
	F 017-	WO98002864	Jul. 1997	WO		
	F 018-	WO 0057643	Sept 2000	WO		
	F 019-	WO 9642151	Dec 1996	WO		
	F 020-	EP0872073	July 1996	EP		

DATE: 03/17/2011	EXAMINER'S SIGNATURE: /Izunna Okeke/
------------------	--------------------------------------

ALL REFERENCES CONSIDERED EXCEPT WHERE LINED THROUGH. //I.O./

Printed: November 19, 2010 (12:45pm)

Path: Y:\Clients\SCOT Scott A Moskowitz and Wistaria Trading,
Inc\SCOT0014-4\Drafts\IDS_SCOT00014-4_11-19-2010.wpd

37 CFR 1.98(a)(1)(i) APPLICATION:

37 CFR 1.98(a)(1)(iii): THIS IS AN INFORMATION DISCLOSURE STATEMENT

EXAMINER INITIALS	REFERENCE NUMBER (F SERIES)	PUBLICATION NUMBER	PUBLICATION DATE	COUNTRY OR REGION	PAGE/LINE AND FIGURE/ELEMENT OF RELEVANT MATERIAL	ENGLISH LANGUAGE TRANSLATION ATTACHED? (YES OR NO) AND/OR IDENTIFICATION OF PRIORITY APPLICATION IN WHICH REFERENCE IS CITED
	F 021-	WO0118628	March 2001	WO		
	F 022-	WO0143026	June 2001	WO		
	F 023-	WO0203385	Jan 2002	WO		
	F 024-	WO9701892	June 1995	WO		
	F 025-	WO9726732	July 1997	WO		
	F 026-	WO9802864	Jan 1998	WO		
	F 027-	EP1547337	Mar 2006	EP		
	F 028-	EP0581317A2	Feb 1994	EP		
	F 029-	WO023385A1	Oct 2002	WO		

DATE: 03/17/2011	EXAMINER'S SIGNATURE: /Izunna Okeke/
------------------	--------------------------------------

ALL REFERENCES CONSIDERED EXCEPT WHERE LINED THROUGH. //I.O./

Printed: November 19, 2010 (12:45pm)

Path: Y:\Clients\SCOT Scott A Moskowitz and Wistaria Trading, Inc\SCOT0014-4\Drafts\IDS_SCOT00014-4_11-19-2010.wpd

37 CFR 1.98(a)(1)(i) APPLICATION:

37 CFR 1.98(a)(1)(iii): THIS IS AN INFORMATION DISCLOSURE STATEMENT

LISTING OF NON PATENT LITERATURE - O Series

EXAMINER INITIALS	REF. NO. (L series)	REFERENCE NUMBER (L Series)	PUB. DATE	INCLUDE IN SEQUENCE: Name of first author (in CAPITAL LETTERS), Title in quotation marks, name of publication, date of publication, page numbers, publisher, city of publication, and country of publication NOTE - For US patent applications listed herein, if a publication of the application is identified, Applicant is citing the listed publication and not submitting a copy of the cited application as filed. The examiner is invited to inspect the IFW as desired to view any application as filed.	ENGLISH LANGUAGE TRANSLATION ATTACHED? (YES OR NO) AND/OR OR IDENTIFICATION OF PRIORITY APPLICATION IN WHICH REFERENCE IS CITED
	1	L- 01	7/28/2009	US. Appl. No. 08/999,766, filed Jul. 23, 1997, entitled "Steganographic Method and Device", published as 7,568,100 07-28-2009.	
	2	L- 02	N/A	EPO Application No. 96919405.9, entitled "Steganographic Method and Device"; published as EP0872073 (A2), published 10-21-1998.	
	3	L- 03	8/11/2005	U.S. Appl. No. 11/050,779, filed Feb. 7, 2005, entitled "Steganographic Method and Device", published as 20050177727 A1 08-11-2005.	
	4	L- 04	4/22/2008	U.S. Appl. No. 08/674,726, filed Jul. 2, 1996, entitled "Exchange Mechanisms for Digital Information Packages with Bandwidth Securitization, Multichannel Digital Watermarks, and Key Management", published as 7,362,775 04-22-2008 .	
	5	L- 05	N/A	U.S. Appl. No. 09/545,589, filed Apr. 7, 2000, entitled "Method and System for Digital Watermarking", published as 7,007,166 02-28-2006	
	6	L- 06	N/A	U.S. Appl. No. 11/244,213, filed Oct. 5, 2005, entitled "Method and System for Digital Watermarking", published as 2006-0101269 A1 05-11-2006	

DATE: 03/17/2011	EXAMINER'S SIGNATURE: /Izunna Okeke/
------------------	--------------------------------------

ALL REFERENCES CONSIDERED EXCEPT WHERE LINED THROUGH. //I.O./

Printed: November 19, 2010 (12:45pm)

Path: Y:\Clients\SCOT Scott A Moskowitz and Wistaria Trading, Inc\SCOT0014-4\Drafts\IDS_SCOT00014-4_11-19-2010.wpd

37 CFR 1.98(a)(1)(i) APPLICATION:

37 CFR 1.98(a)(1)(iii): THIS IS AN INFORMATION DISCLOSURE STATEMENT

EXAMINER INITIALS	REF. NO. (L series)	REFERENCE NUMBER (L Series)	PUB. DATE	INCLUDE IN SEQUENCE: Name of first author (in CAPITAL LETTERS), Title in quotation marks, name of publication, date or publication, page numbers, publisher, city of publication, and country of publication NOTE - For US patent applications listed herein, if a publication of the application is identified, Applicant is citing the listed publication and not submitting a copy of the cited application as filed. The examiner is invited to inspect the IFW as desired to view any application as filed.	ENGLISH LANGUAGE TRANSLATION ATTACHED? (YES OR NO) AND/OR OR IDENTIFICATION OF PRIORITY APPLICATION IN WHICH REFERENCE IS CITED
	7	L- 07	N/A	U.S. Appl. No. 11/649,026, filed Jan. 3, 2007, entitled "Method and System for Digital Watermarking", published as 2007-0113094 A1 05-17-2007.	
	8	L- 08	N/A	U.S. Appl. No. 09/046,627, filed Mar. 24, 1998, entitled "Method for Combining Transfer Function with Predetermined Key Creation", published as 6,598,162 07-22-2003 .	
	9	L- 09	N/A	U.S. Appl. No. 10/602,777, filed Jun. 25, 2003, entitled "Method for Combining Transfer Function with Predetermined Key Creation", published as 2004-0086119 A1 05-06-2004	
	10	L- 010	N/A	U.S. Appl. No. 09/053,628, filed Apr. 2, 1998, entitled "Multiple Transform Utilization and Application for Secure Digital Watermarking", 6,205,249 03-20-2001	
	11	L- 011	N/A	U.S. Appl. No. 09/644,098, filed Aug. 23, 2000, entitled "Multiple Transform Utilization and Application for Secure Digital Watermarking", published as 7,035,409 04-25-2006	
	12	L- 012	N/A	Jap. App. No. 2000-542907, entitled "Multiple Transform Utilization and Application for Secure Digital Watermarking", JP national stage of PCT/US1999/007262, published as WO99052271, 10/14/1999, F13 here in above.	

DATE: 03/17/2011	EXAMINER'S SIGNATURE: /Izunna Okeke/
------------------	--------------------------------------

ALL REFERENCES CONSIDERED EXCEPT WHERE LINED THROUGH. //I.O./

Printed: November 19, 2010 (12:45pm)

Path: Y:\Clients\SCOT Scott A Moskowitz and Wistaria Trading, Inc\SCOT0014-4\Drafts\IDS_SCOT00014-4_11-19-2010.wpd

37 CFR 1.98(a)(1)(i) APPLICATION:

37 CFR 1.98(a)(1)(iii): THIS IS AN INFORMATION DISCLOSURE STATEMENT

EXAMINER INITIALS	REF. NO. (L series)	REFERENCE NUMBER (L Series)	PUB. DATE	INCLUDE IN SEQUENCE: Name of first author (in CAPITAL LETTERS), Title in quotation marks, name of publication, date or publication, page numbers, publisher, city of publication, and country of publication NOTE - For US patent applications listed herein, if a publication of the application is identified, Applicant is citing the listed publication and not submitting a copy of the cited application as filed. The examiner is invited to inspect the IFW as desired to view any application as filed.	ENGLISH LANGUAGE TRANSLATION ATTACHED? (YES OR NO) AND/OR OR IDENTIFICATION OF PRIORITY APPLICATION IN WHICH REFERENCE IS CITED
	13	L- 013	N/A	U.S. Appl. No. 09/767,733, filed Jan. 24, 2001, entitled "Multiple Transform Utilization and Application for Secure Digital Watermarking", published as 2001-0010078 A1 07-26-2001.	
	14	L- 014	N/A	U.S. Appl. No. 11/358,874, filed Feb. 21, 2006, entitled "Multiple Transform Utilization and Application for Secure Digital Watermarking", published as 2006-0140403 A1 06-29-2006	
	15	L- 015	N/A	U.S. Appl. No. 10/417,231, filed Apr. 17, 2003, entitled "Methods, Systems And Devices For Packet Watermarking And Efficient Provisioning Of Bandwidth", published as 2003-0200439 A1 10-23-2003	
	16	L- 016	N/A	U.S. Appl. No. 09/789,711, filed Feb. 22, 2001, entitled "Optimization Methods for the Insertion, Protection, and Detection of Digital Watermarks in Digital Data", published as 2001-0029580 A1 10-11-2001.	
	17	L- 017	N/A	U.S. Appl. No. 11/497,822, filed Aug. 2, 2006, entitled "Optimization Methods for the Insertion, Protection, and Detection of Digital Watermarks in Digital Data", published as 2007-0011458 A1 01-11-2007	

DATE: 03/17/2011	EXAMINER'S SIGNATURE: /Izunna Okeke/
------------------	--------------------------------------

ALL REFERENCES CONSIDERED EXCEPT WHERE LINED THROUGH. //I.O./

Printed: November 19, 2010 (12:45pm)

Path: Y:\Clients\SCOT Scott A Moskowitz and Wistaria Trading, Inc\SCOT0014-4\Drafts\IDS_SCOT00014-4_11-19-2010.wpd

37 CFR 1.98(a)(1)(i) APPLICATION:

37 CFR 1.98(a)(1)(iii): THIS IS AN INFORMATION DISCLOSURE STATEMENT

EXAMINER INITIALS	REF. NO. (L series)	REFERENCE NUMBER (L Series)	PUB. DATE	INCLUDE IN SEQUENCE: Name of first author (in CAPITAL LETTERS), Title in quotation marks, name of publication, date or publication, page numbers, publisher, city of publication, and country of publication NOTE - For US patent applications listed herein, if a publication of the application is identified, Applicant is citing the listed publication and not submitting a copy of the cited application as filed. The examiner is invited to inspect the IFW as desired to view any application as filed.	ENGLISH LANGUAGE TRANSLATION ATTACHED? (YES OR NO) AND/OR OR IDENTIFICATION OF PRIORITY APPLICATION IN WHICH REFERENCE IS CITED
	18	L- 018	N/A	U.S. Appl. No. 11/599,964, filed Nov. 15, 2006, entitled "Optimization Methods for the Insertion, Protection, and Detection of Digital Watermarks in Digital Data", published as 2008-0046742 A1 02-21-2008.	
	19	L- 019	N/A	U.S. Appl. No. 11/599,838, filed Nov. 15, 2006, entitled "Optimization Methods for the Insertion, Protection, and Detection of Digital Watermarks in Digital Data", published as 2007-0226506 A1 09-27-2007	
	20	L- 020	N/A	U.S. Appl. No. 10/369,344, filed Feb. 18, 2003, entitled "Optimization Methods for the Insertion, Protection, and Detection of Digital Watermarks in Digitized Data", published as 2003-0219143 A1 11-27-2003.	
	21	L- 021	N/A	U.S. Appl. No. 11/482,654, filed Jul. 7, 2006, entitled "Optimization Methods for the Insertion, Protection, and Detection of Digital Watermarks in Digitized Data", published as 2006-0285722 A1 12-21-2006.	
	22	L- 022	N/A	U.S. Appl. No. 09/594,719, filed Jun. 16, 2000, entitled "Utilizing Data Reduction in Steganographic and Cryptographic Systems", published as 7,123,718 10-17-2006 .	

DATE: 03/17/2011	EXAMINER'S SIGNATURE: /Izunna Okeke/
------------------	--------------------------------------

ALL REFERENCES CONSIDERED EXCEPT WHERE LINED THROUGH. //I.O./

Printed: November 19, 2010 (12:45pm)

Path: Y:\Clients\SCOT Scott A Moskowitz and Wistaria Trading, Inc\SCOT0014-4\Drafts\IDS_SCOT00014-4_11-19-2010.wpd

37 CFR 1.98(a)(1)(i) APPLICATION:

37 CFR 1.98(a)(1)(iii): THIS IS AN INFORMATION DISCLOSURE STATEMENT

EXAMINER INITIALS	REF. NO. (L series)	REFERENCE NUMBER (L Series)	PUB. DATE	INCLUDE IN SEQUENCE: Name of first author (in CAPITAL LETTERS), Title in quotation marks, name of publication, date or publication, page numbers, publisher, city of publication, and country of publication NOTE - For US patent applications listed herein, if a publication of the application is identified, Applicant is citing the listed publication and not submitting a copy of the cited application as filed. The examiner is invited to inspect the IFW as desired to view any application as filed.	ENGLISH LANGUAGE TRANSLATION ATTACHED? (YES OR NO) AND/OR OR IDENTIFICATION OF PRIORITY APPLICATION IN WHICH REFERENCE IS CITED
	23	L- 023	N/A	U.S. Appl. No. 11/519,467, filed Sep. 12, 2006, entitled "Utilizing Data Reduction in Steganographic and Cryptographic Systems", published as 2007-0064940 A1 03-22-2007.	
	24	L- 024	N/A	U.S. Appl. No. 09/731,040, filed Dec. 7, 2000, entitled "Systems, Methods And Devices For Trusted Transactions", 2002-0010684 A1 01-24-2002.	
	25	L- 025	N/A	U.S. Appl. No. 11/512,701, filed Aug. 29, 2006, entitled "Systems, Methods And Devices For Trusted Transactions", published as 2007-0028113 A1 02-01-2007.	
	26	L- 026	N/A	U.S. Appl. No. 10/049,101, filed Feb. 8, 2002, entitled "A Secure Personal Content Server", published as 7,475,246 01-06-2009.	
	27	L- 027	N/A	PCT Application No. PCT/US00/21189, filed Aug. 4, 2000, entitled, "A Secure Personal Content Server", Pub. No.: WO018628 ; Publication Date: 15.03.2001, F21 here in above.	
	28	L- 028	N/A	U.S. Appl. No. 09/657,181, filed Sep. 7, 2000, entitled "Method and Device For Monitoring And Analyzing Signals", published as 7,346,472 03-18-2008.	

DATE: 03/17/2011	EXAMINER'S SIGNATURE: /Izunna Okeke/
------------------	--------------------------------------

ALL REFERENCES CONSIDERED EXCEPT WHERE LINED THROUGH. //I.O./

Printed: November 19, 2010 (12:45pm)

Path: Y:\Clients\SCOT Scott A Moskowitz and Wistaria Trading, Inc\SCOT0014-4\Drafts\IDS_SCOT00014-4_11-19-2010.wpd

37 CFR 1.98(a)(1)(i) APPLICATION:

37 CFR 1.98(a)(1)(iii): THIS IS AN INFORMATION DISCLOSURE STATEMENT

EXAMINER INITIALS	REF. NO. (L series)	REFERENCE NUMBER (L Series)	PUB. DATE	INCLUDE IN SEQUENCE: Name of first author (in CAPITAL LETTERS), Title in quotation marks, name of publication, date or publication, page numbers, publisher, city of publication, and country of publication NOTE - For US patent applications listed herein, if a publication of the application is identified, Applicant is citing the listed publication and not submitting a copy of the cited application as filed. The examiner is invited to inspect the IFW as desired to view any application as filed.	ENGLISH LANGUAGE TRANSLATION ATTACHED? (YES OR NO) AND/OR OR IDENTIFICATION OF PRIORITY APPLICATION IN WHICH REFERENCE IS CITED
	29	L- 029	N/A	U.S. Appl. No. 10/805,484, filed Mar. 22, 2004, entitled "Method And Device For Monitoring And Analyzing Signals", published as 2004-0243540 A1 12-02-2004.	
	30	L- 030	N/A	U.S. Appl. No. 09/956,262, filed Sep. 20, 2001, entitled "Improved Security Based on Subliminal and Supraliminal Channels For Data Objects", published as 2002-0056041 A1 05-09-2002	
	31	L- 031	N/A	U.S. Appl. No. 11/518,806, filed Sep. 11, 2006, entitled "Improved Security Based on Subliminal and Supraliminal Channels For Data Objects", 2008-0028222 A1 01-31-2008 .	
	32	L- 032	N/A	U.S. Appl. No. 11/026,234, filed Dec. 30, 2004, entitled "Z-Transform Implementation of Digital Watermarks" , published as 2005-0135615 A1 06-23-2005.	
	33	L- 033	N/A	U.S. Appl. No. 11/592,079, filed Nov. 2, 2006, entitled "Linear Predictive Coding Implementation of Digital Watermarks", published as 2007-0079131 A1 04-05-2007.	
	34	L- 034	N/A	U.S. Appl. No. 09/731,039, filed Dec. 7, 2000, entitled "System and Methods for Permitting Open Access to Data Objects and for Securing Data within the Data Objects", published as 2002-0071556 A1 06-13-2002	

DATE: 03/17/2011	EXAMINER'S SIGNATURE: /Izunna Okeke/
------------------	--------------------------------------

ALL REFERENCES CONSIDERED EXCEPT WHERE LINED THROUGH. //I.O./

Printed: November 19, 2010 (12:45pm)

Path: Y:\Clients\SCOT Scott A Moskowitz and Wistaria Trading, Inc\SCOT0014-4\Drafts\IDS_SCOT00014-4_11-19-2010.wpd

37 CFR 1.98(a)(1)(i) APPLICATION:

37 CFR 1.98(a)(1)(iii): THIS IS AN INFORMATION DISCLOSURE STATEMENT

EXAMINER INITIALS	REF. NO. (L series)	REFERENCE NUMBER (L Series)	PUB. DATE	INCLUDE IN SEQUENCE: Name of first author (in CAPITAL LETTERS), Title in quotation marks, name of publication, date or publication, page numbers, publisher, city of publication, and country of publication NOTE - For US patent applications listed herein, if a publication of the application is identified, Applicant is citing the listed publication and not submitting a copy of the cited application as filed. The examiner is invited to inspect the IFW as desired to view any application as filed.	ENGLISH LANGUAGE TRANSLATION ATTACHED? (YES OR NO) AND/OR OR IDENTIFICATION OF PRIORITY APPLICATION IN WHICH REFERENCE IS CITED
	35	L- 035	N/A	U.S. Appl. No. 11/647,861, filed Dec. 29, 2006, entitled "System and Methods for Permitting Open Access to Data Objects and for Securing Data within the Data Objects", published as 2007-0110240 A1 05-17-2007.	
	36	L- 036	1996	Schneier, Bruce, Applied Cryptography, 2nd Ed., John Wiley & Sons, pp. 9-10, 1996.	
	37	L- 037	1997	Menezes, Alfred J., Handbook of Applied Cryptography, CRC Press, p. 46, 1997.	
	38	L- 038	1997	Merriam-Webster's Collegiate Dictionary, 10th Ed., Merriam Webster, Inc., p. 207.	
	39	L- 039	1984	Brealy, et al., Principles of Corporate Finance, "Appendix A--Using Option Valuation Models", 1984, pp. 448-449.	
	40	L- 040	2001	Copeland, et al., Real Options: A Practitioner's Guide, 2001 pp. 106-107, 201-202, 204-208.	
	41	L- 041	1995	Sarkar, M. "An Assessment of Pricing Mechanisms for the Internet-A Regulatory Imperative", presented MIT Workshop on Internet Economics, Mar. 1995 http://www.press.vmich.edu/iep/works/SarkAsses.html	

DATE: 03/17/2011	EXAMINER'S SIGNATURE: /Izunna Okeke/
------------------	--------------------------------------

ALL REFERENCES CONSIDERED EXCEPT WHERE LINED THROUGH. //I.O./

Printed: November 19, 2010 (12:45pm)

Path: Y:\Clients\SCOT Scott A Moskowitz and Wistaria Trading, Inc\SCOT0014-4\Drafts\IDS_SCOT00014-4_11-19-2010.wpd

37 CFR 1.98(a)(1)(i) APPLICATION:

37 CFR 1.98(a)(1)(iii): THIS IS AN INFORMATION DISCLOSURE STATEMENT

EXAMINER INITIALS	REF. NO. (L series)	REFERENCE NUMBER (L Series)	PUB. DATE	INCLUDE IN SEQUENCE: Name of first author (in CAPITAL LETTERS), Title in quotation marks, name of publication, date or publication, page numbers, publisher, city of publication, and country of publication NOTE - For US patent applications listed herein, if a publication of the application is identified, Applicant is citing the listed publication and not submitting a copy of the cited application as filed. The examiner is invited to inspect the IFW as desired to view any application as filed.	ENGLISH LANGUAGE TRANSLATION ATTACHED? (YES OR NO) AND/OR OR IDENTIFICATION OF PRIORITY APPLICATION IN WHICH REFERENCE IS CITED
	42	L- 042	1995	Crawford, D.W. "Pricing Network Usage: A Market for Bandwidth of Market Communication?" presented MIT Workshop on Internet Economics, Mar. 1995 http://www.press.vtmich.edu/iep/works/CrawMarket.html on March.	
	43	L- 043	1988	Low, S.H., "Equilibrium Allocation and Pricing of Variable Resources Among User-Suppliers", 1988. http://www.citesear.nj.nec.com/366503.html .	
	44	L- 044	1995	Caronni, Germano, "Assuring Ownership Rights for Digital Images", published proceeds of reliable IT systems, v15 '95, H.H. Bruggemann and W. Gerhardt-Hackel (Ed) Viewing Publishing Company Germany 1995.	
	45	L- 045	1996	Zhao, Jian. "A WWW Service to Embed and Prove Digital Copyright Watermarks", Proc. of the European conf. on Multimedia Applications, Services & Techniques Louvain-La-Neuve Belgium May 1996.	
	46	L- 046	1996	Gruhl, Daniel et al., Echo Hiding. In Proceeding of the Workshop on Information Hiding. No. 1174 in Lecture Notes in Computer Science, Cambridge, England (May/Jun. 1996).	

DATE: 03/17/2011	EXAMINER'S SIGNATURE: /Izunna Okeke/
------------------	--------------------------------------

ALL REFERENCES CONSIDERED EXCEPT WHERE LINED THROUGH. //I.O./

Printed: November 19, 2010 (12:45pm)

Path: Y:\Clients\SCOT Scott A Moskowitz and Wistaria Trading, Inc\SCOT0014-4\Drafts\IDS_SCOT00014-4_11-19-2010.wpd

37 CFR 1.98(a)(1)(i) APPLICATION:

37 CFR 1.98(a)(1)(iii): THIS IS AN INFORMATION DISCLOSURE STATEMENT

EXAMINER INITIALS	REF. NO. (L series)	REFERENCE NUMBER (L Series)	PUB. DATE	INCLUDE IN SEQUENCE: Name of first author (in CAPITAL LETTERS), Title in quotation marks, name of publication, date or publication, page numbers, publisher, city of publication, and country of publication NOTE - For US patent applications listed herein, if a publication of the application is identified, Applicant is citing the listed publication and not submitting a copy of the cited application as filed. The examiner is invited to inspect the IFW as desired to view any application as filed.	ENGLISH LANGUAGE TRANSLATION ATTACHED? (YES OR NO) AND/OR OR IDENTIFICATION OF PRIORITY APPLICATION IN WHICH REFERENCE IS CITED
	47	L- 047	1995	Oomen, A.W.J. et al., A Variable Bit Rate Buried Data Channel for Compact Disc, J.AudioEng. Sc., vol. 43, No. 1/2, pp. 23-28 (1995).	
	48	L- 048	1992	Ten Kate, W. et al., A New Surround-Stereo-Surround Coding Techniques, J. Audio Eng.Soc., vol. 40,No. 5,pp. 376-383 (1992).	
	49	L- 049	1993	Gerzon, Michael et al., A High Rate Buried Data Channel for Audio CD, presentation notes, Audio Engineering Soc. 94th Convention (1993).	
	50	L- 050	1988	Sklar, Bernard, Digital Communications, pp. 601-603 (1988).	
	51	L- 051	1984	Jayant, N.S. et al., Digital Coding of Waveforms, Prentice Hall Inc., Englewood Cliffs, NJ, pp. 486-509 (1984)	
	52	L- 052	1995	Bender, Walter R. et al., Techniques for Data Hiding, SPIE Int. Soc. Opt. Eng., vol. 2420, pp. 164-173, 1995.	
	53	L- 053	1995	Zhao, Jian et al., Embedding Robust Labels into Images for Copyright Protection, (xp 000571976), pp. 242-251, 1995.	
	54	L- 054	1997	Menezes, Alfred J., Handbook of Applied Cryptography, CRC Press, p. 175, 1997.	

DATE: 03/17/2011	EXAMINER'S SIGNATURE: /Izunna Okeke/
------------------	--------------------------------------

ALL REFERENCES CONSIDERED EXCEPT WHERE LINED THROUGH. //I.O./

Printed: November 19, 2010 (12:45pm)

Path: Y:\Clients\SCOT Scott A Moskowitz and Wistaria Trading, Inc\SCOT0014-4\Drafts\IDS_SCOT00014-4_11-19-2010.wpd

37 CFR 1.98(a)(1)(i) APPLICATION:

37 CFR 1.98(a)(1)(iii): THIS IS AN INFORMATION DISCLOSURE STATEMENT

EXAMINER INITIALS	REF. NO. (L series)	REFERENCE NUMBER (L Series)	PUB. DATE	INCLUDE IN SEQUENCE: Name of first author (in CAPITAL LETTERS), Title in quotation marks, name of publication, date or publication, page numbers, publisher, city of publication, and country of publication NOTE - For US patent applications listed herein, if a publication of the application is identified, Applicant is citing the listed publication and not submitting a copy of the cited application as filed. The examiner is invited to inspect the IFW as desired to view any application as filed.	ENGLISH LANGUAGE TRANSLATION ATTACHED? (YES OR NO) AND/OR OR IDENTIFICATION OF PRIORITY APPLICATION IN WHICH REFERENCE IS CITED
	55	L- 055	1994	Schneier, Bruce, Applied Cryptography, 1st Ed., pp. 67-68, 1994.	
	56	L- 056	1990	Ten Kate, W. et al., "Digital Audio Carrying Extra Information", IEEE, CH 2847-2/90/0000-1097, (1990).	
	57	L- 057	1994	Van Schyndel, et al., "A digital Watermark," IEEE Int'l Computer Processing Conference, Austin, TX, Nov. 13-16, 1994, pp. 86-90.	
	58	L- 058	1996	Smith, et al. "Modulation and Information Hiding in Images", Springer Verlag, 1st Int'l Workshop, Cambridge, UK, May 30-Jun. 1, 1996, pp. 207-227.	
	59	L- 059	1997	Kutter, Martin et al., "Digital Signature of Color Images Using Amplitude Modulation", SPIE-E197, vol. 3022, pp. 518-527.	
	60	L- 060	1997	Puate, Joan et al., "Using Fractal Compression Scheme to Embed a Digital Signature into an Image", SPIE-96 Proceedings, vol. 2915, Mar. 1997, pp. 108-118.	
	61	L- 061	1996	Swanson, Mitchell D., et al., "Transparent Robust Image Watermarking", Proc. of the 1996 IEEE Int'l Conf. on Image Processing, vol. 111, 1996, pp. 211-214.	
	62	L- 062	1996	Swanson, Mitchell D., et al. "Robust Data Hiding for Images", 7th IEEE Digital Signal Processing Workshop, Leon, Norway, Sep. 1-4, 1996, pp. 37-40.	
DATE: 03/17/2011			EXAMINER'S SIGNATURE: /Izunna Okeke/		

ALL REFERENCES CONSIDERED EXCEPT WHERE LINED THROUGH. //I.O./

Printed: November 19, 2010 (12:45pm)

Path: Y:\Clients\SCOT Scott A Moskowitz and Wistaria Trading, Inc\SCOT0014-4\Drafts\IDS_SCOT00014-4_11-19-2010.wpd

37 CFR 1.98(a)(1)(i) APPLICATION:

37 CFR 1.98(a)(1)(iii): THIS IS AN INFORMATION DISCLOSURE STATEMENT

EXAMINER INITIALS	REF. NO. (L series)	REFERENCE NUMBER (L Series)	PUB. DATE	INCLUDE IN SEQUENCE: Name of first author (in CAPITAL LETTERS), Title in quotation marks, name of publication, date or publication, page numbers, publisher, city of publication, and country of publication NOTE - For US patent applications listed herein, if a publication of the application is identified, Applicant is citing the listed publication and not submitting a copy of the cited application as filed. The examiner is invited to inspect the IFW as desired to view any application as filed.	ENGLISH LANGUAGE TRANSLATION ATTACHED? (YES OR NO) AND/OR OR IDENTIFICATION OF PRIORITY APPLICATION IN WHICH REFERENCE IS CITED
	63	L- 063	Unknown	Zhao, Jian et al., "Embedding Robust Labels into Images for Copyright Protection", Proceeding of the Know Right '95 Conference, pp. 242-251.	
	64	L- 064	1995	Koch, E., et al., "Towards Robust and Hidden Image Copyright Labeling", 1995 IEEE Workshop on Nonlinear Signal and Image Processing, Jun. 1995 Neos Marmaras pp. 4.	
	65	L- 065	1995	Van Schyandel, et al., "Towards a Robust Digital Watermark", Second Asain Image Processing Conference, Dec. 6-8, 1995, Singapore, vol. 2, pp. 504-508.	
	66	L- 066	1995	Tirkel,A.Z., "A Two-Dimensional Digital Watermark", DICTA '95, Univ. of Queensland, Brisbane, Dec. 5-8, 1995, pp. 7.	
	67	L- 067	1996	Tirkel,A.Z., "Image Watermarking--A Spread Spectrum Application", ISSSTA '96, Sep. 1996, Mainz, German, pp. 6.	
	68	L- 068	1996	O'Ruanaidh, et al. "Watermarking Digital Images for Copyright Protection", IEEE Proceedings, vol. 143, No. 4, Aug. 1996, pp. 250-256.	

DATE: 03/17/2011	EXAMINER'S SIGNATURE: /Izunna Okeke/
------------------	--------------------------------------

ALL REFERENCES CONSIDERED EXCEPT WHERE LINED THROUGH. //I.O./

Printed: November 19, 2010 (12:45pm)

Path: Y:\Clients\SCOT Scott A Moskowitz and Wistaria Trading, Inc\SCOT0014-4\Drafts\IDS_SCOT00014-4_11-19-2010.wpd

37 CFR 1.98(a)(1)(i) APPLICATION:

37 CFR 1.98(a)(1)(iii): THIS IS AN INFORMATION DISCLOSURE STATEMENT

EXAMINER INITIALS	REF. NO. (L series)	REFERENCE NUMBER (L Series)	PUB. DATE	INCLUDE IN SEQUENCE: Name of first author (in CAPITAL LETTERS), Title in quotation marks, name of publication, date or publication, page numbers, publisher, city of publication, and country of publication NOTE - For US patent applications listed herein, if a publication of the application is identified, Applicant is citing the listed publication and not submitting a copy of the cited application as filed. The examiner is invited to inspect the IFW as desired to view any application as filed.	ENGLISH LANGUAGE TRANSLATION ATTACHED? (YES OR NO) AND/OR OR IDENTIFICATION OF PRIORITY APPLICATION IN WHICH REFERENCE IS CITED
	69	L- 069	Unknown	Cox, et al., Secure Spread Spectrum Watermarking for Multimedia, NEC Research Institute, Techinal Report 95-10, pp. 33.	
	70	L- 070	1969	Kahn, D., "The Code Breakers", The MacMillan Company, 1969, pp. xIII, 81-83, 513, 515, 522-526, 863.	
	71	L- 071	1997	Boney, et al., Digital Watermarks for Audio Signals, EVSIPCO, 96, pp. 473-480 (3/14/1997).	
	72	L- 072	1996	Dept. of Electrical Engineering, Del Ft University of Technology, Del ft The Netherlands, Cr.C. Langelaar et al., "Copy Protection for Multimedia Data based on Labeling Techniques", Jul. 1996 9 pp.	
	73	L- 073	Unknown	F. Hartung, et al., "Digital Watermarking of Raw and Compressed Video", SPIE vol. 2952, pp. 205-213.	
	74	L- 074	1996	Craver, et al., "Can Invisible Watermarks Resolve Rightful Ownerships?", IBM Research Report, RC 20509 (Jul. 25, 1996) 21 pp.	
	75	L- 075	1988	Press, et al., "Numerical Recipes in C", Cambridge Univ. Press, 1988, pp. 398-417.	
	76	L- 076	1995	Pohlmann, Ken C., "Principles of Digital Audio", 3rd Ed., 1995, pp. 32-37, 40-48:138, 147-149, 332, 333, 364, 499-501, 508-509, 564-571.	
DATE: 03/17/2011			EXAMINER'S SIGNATURE: /Izunna Okeke/		

ALL REFERENCES CONSIDERED EXCEPT WHERE LINED THROUGH. //I.O./

Printed: November 19, 2010 (12:45pm)

Path: Y:\Clients\SCOT Scott A Moskowitz and Wistaria Trading, Inc\SCOT0014-4\Drafts\IDS_SCOT00014-4_11-19-2010.wpd

37 CFR 1.98(a)(1)(i) APPLICATION:

37 CFR 1.98(a)(1)(iii): THIS IS AN INFORMATION DISCLOSURE STATEMENT

EXAMINER INITIALS	REF. NO. (L series)	REFERENCE NUMBER (L Series)	PUB. DATE	INCLUDE IN SEQUENCE: Name of first author (in CAPITAL LETTERS), Title in quotation marks, name of publication, date or publication, page numbers, publisher, city of publication, and country of publication NOTE - For US patent applications listed herein, if a publication of the application is identified, Applicant is citing the listed publication and not submitting a copy of the cited application as filed. The examiner is invited to inspect the IFW as desired to view any application as filed.	ENGLISH LANGUAGE TRANSLATION ATTACHED? (YES OR NO) AND/OR OR IDENTIFICATION OF PRIORITY APPLICATION IN WHICH REFERENCE IS CITED
	77	L- 077	1991	Pohlmann, Ken C., "Principles of Digital Audio", 2nd Ed., 1991, pp. 1-9, 19-25, 30-33, 41-48, 54-57, 86-107, 375-387.	
	78	L- 078	1994	Schneier, Bruce, Applied Cryptography, John Wiley & Sons, Inc., New York, 1994, pp. 68, 69, 387-392, 1-57, 273-275, 321-324.	
	79	L- 079	1996	Boney, et al., Digital Watermarks for Audio Signals, Proceedings of the International Conf. on Multimedia Computing and Systems, Jun. 17-23, 1996 Hiroshima, Japan, 0-8186-7436-9196, pp. 473-480.	
	80	L- 080	1998	Johnson, et al., "Transform Permuted Watermarking for Copyright Protection of Digital Video", IEEE Globecom 1998, Nov. 8-12, 1998, New York New York vol. 2 1998 pp. 684-689 (ISBN 0-7803-4985-7).	
	81	L- 081	1996	Rivest, et al., "Pay Word and Micromint: Two Simple Micropayment Schemes," MIT Laboratory for Computer Science, Cambridge, MA, May 7, 1996 pp. 1-18.	
	82	L- 082	1996	Bender, et al., "Techniques for Data Hiding", IBM Systems Journal, (1996) vol. 35, Nos. 3 & 4, 1996, pp. 313-336.	

DATE: 03/17/2011	EXAMINER'S SIGNATURE: /Izunna Okeke/
------------------	--------------------------------------

ALL REFERENCES CONSIDERED EXCEPT WHERE LINED THROUGH. //I.O./

Printed: November 19, 2010 (12:45pm)

Path: Y:\Clients\SCOT Scott A Moskowitz and Wistaria Trading, Inc\SCOT0014-4\Drafts\IDS_SCOT00014-4_11-19-2010.wpd

37 CFR 1.98(a)(1)(i) APPLICATION:

37 CFR 1.98(a)(1)(iii): THIS IS AN INFORMATION DISCLOSURE STATEMENT

EXAMINER INITIALS	REF. NO. (L series)	REFERENCE NUMBER (L Series)	PUB. DATE	INCLUDE IN SEQUENCE: Name of first author (in CAPITAL LETTERS), Title in quotation marks, name of publication, date or publication, page numbers, publisher, city of publication, and country of publication NOTE - For US patent applications listed herein, if a publication of the application is identified, Applicant is citing the listed publication and not submitting a copy of the cited application as filed. The examiner is invited to inspect the IFW as desired to view any application as filed.	ENGLISH LANGUAGE TRANSLATION ATTACHED? (YES OR NO) AND/OR OR IDENTIFICATION OF PRIORITY APPLICATION IN WHICH REFERENCE IS CITED
	83	L- 083	2003	Moskowitz, "Bandwith as Currency", IEEE Multimedia, Jan.-Mar. 2003, pp. 14-21.	
	84	L- 084	2006	Moskowitz, Multimedia Security Technologies for Digital Rights Management, 2006, Academic Press, "Introduction--Digital Rights Management" pp. 3-22.	
	85	L- 085	2001	Rivest, et al., "PayWord and Micromint: Two Simple Micropayment Schemes," MIT Laboratory for Computer Science, Cambridge, MA, Apr. 27, 2001, pp. 1-18.	
	86	L- 086	2000	Tomsich, et al., "Towards a secure and de-centralized digital watermarking infrastructure for the protection of Intellectual Property", in Electronic Commerce and Web Technologies, Proceedings (ECWEB)(2000).	
	87	L- 087	2002	Moskowitz, "What is Acceptable Quality in the Application of Digital Watermarking: Trade-offs of Security; Robustness and Quality", IEEE Computer Society Proceedings of ITCC 2002 Apr. 10, 2002 pp. 80-84.	
	88	L- 088	2006	Lemma, et al. "Secure Watermark Embedding through Partial Encryption", International Workshop on Digital Watermarking" ("IWDW" 2006). Springer Lecture Notes in Computer Science 2006 (to appear) 13.	

DATE: 03/17/2011	EXAMINER'S SIGNATURE: /Izunna Okeke/
------------------	--------------------------------------

ALL REFERENCES CONSIDERED EXCEPT WHERE LINED THROUGH. //I.O./

Printed: November 19, 2010 (12:45pm)

Path: Y:\Clients\SCOT Scott A Moskowitz and Wistaria Trading, Inc\SCOT0014-4\Drafts\IDS_SCOT00014-4_11-19-2010.wpd

37 CFR 1.98(a)(1)(i) APPLICATION:

37 CFR 1.98(a)(1)(iii): THIS IS AN INFORMATION DISCLOSURE STATEMENT

EXAMINER INITIALS	REF. NO. (L series)	REFERENCE NUMBER (L Series)	PUB. DATE	INCLUDE IN SEQUENCE: Name of first author (in CAPITAL LETTERS), Title in quotation marks, name of publication, date or publication, page numbers, publisher, city of publication, and country of publication NOTE - For US patent applications listed herein, if a publication of the application is identified, Applicant is citing the listed publication and not submitting a copy of the cited application as filed. The examiner is invited to inspect the IFW as desired to view any application as filed.	ENGLISH LANGUAGE TRANSLATION ATTACHED? (YES OR NO) AND/OR OR IDENTIFICATION OF PRIORITY APPLICATION IN WHICH REFERENCE IS CITED
	89	L- 089	2002	Kocher, et al., "Self Protecting Digital Content", Technical Report from the CRI Content Security Research Initiative, Cryptography Research, Inc. 2002-2003 14 pages.	
	90	L- 090	1995	Sirbu, M. et al., "Net Bill: An Internet Commerce System Optimized for Network Delivered Services", Digest of Papers of the Computer Society Computer Conference (Spring) Mar. 5, 1995 pp. 20-25 vol. CONF40.	
	91	L- 091	1998	Schunter, M. et al., "A Status Report on the SEMPER framework for Secure Electronic Commerce", Computer Networks and ISDN Systems, Sep. 30, 1998, pp. 1501-1510 vol. 30 No. 16-18 NL North Holland.	
	92	L- 092	1999	Konrad, K. et al., "Trust and Electronic Commerce--more than a technical problem," Proceedings of the 18th IEEE Symposium on Reliable Distributed Systems Oct. 19-22, 1999, pp. 360-365 Lausanne.	
	93	L- 093	1998	Kini, et al., "Trust in Electronic Commerce: Definition and Theoretical Considerations", Proceedings of the 31st Hawaii Int'l Conf on System Sciences (Cat. No. 98TB100216), Jan. 6-9, 1998, pp. 51-61. Los.	

DATE: 03/17/2011	EXAMINER'S SIGNATURE: /Izunna Okeke/
------------------	--------------------------------------

ALL REFERENCES CONSIDERED EXCEPT WHERE LINED THROUGH. //I.O./

Printed: November 19, 2010 (12:45pm)

Path: Y:\Clients\SCOT Scott A Moskowitz and Wistaria Trading, Inc\SCOT0014-4\Drafts\IDS_SCOT00014-4_11-19-2010.wpd

37 CFR 1.98(a)(1)(i) APPLICATION:

37 CFR 1.98(a)(1)(iii): THIS IS AN INFORMATION DISCLOSURE STATEMENT

EXAMINER INITIALS	REF. NO. (L series)	REFERENCE NUMBER (L Series)	PUB. DATE	INCLUDE IN SEQUENCE: Name of first author (in CAPITAL LETTERS), Title in quotation marks, name of publication, date or publication, page numbers, publisher, city of publication, and country of publication NOTE - For US patent applications listed herein, if a publication of the application is identified, Applicant is citing the listed publication and not submitting a copy of the cited application as filed. The examiner is invited to inspect the IFW as desired to view any application as filed.	ENGLISH LANGUAGE TRANSLATION ATTACHED? (YES OR NO) AND/OR OR IDENTIFICATION OF PRIORITY APPLICATION IN WHICH REFERENCE IS CITED
	94	L- 094	1997	Steinauer D. D., et al., "Trust and Traceability in Electronic Commerce", Standard View, Sep. 1997, pp. 118-124, vol. 5 No. 3, ACM, USA.	
	95	L- 095	1999	Hartung, et al. "Multimedia Watermarking Techniques", Proceedings of the IEEE, Special Issue, Identification & Protection of Multimedia Information, pp. 1079-1107 Jul. 1999 vol. 87 No. 7 IEEE.	
	96	L- 096	N/A	European Search Report & European Search Opinion in EP07112420	
	97	L- 097	2006	STAIND (The Singles 1996-2006), Warner Music--Atlantic, Pre-Release CD image, 2006, 1 page.	
	98	L- 098		DUPLICATE OF L-97, DELETED BY 11/16/2010 by RAN.	
	99	L- 099	2003	Radiohead ("Hail To The Thief"), EMI Music Group--Capitol, Pre-Release CD image, 2003, 1 page.	
	100	L- 0100	N/A	DUPLICATE OF L-4, DELETED BY RN UPON REVIEW ON 11/18/2010. RAN	
	101	L- 0101	N/A	U.S. Appl. No. 60/169,274, filed Dec. 7, 1999, entitled "Systems, Methods And Devices For Trusted Transactions".	

DATE: 03/17/2011	EXAMINER'S SIGNATURE: /Izunna Okeke/
------------------	--------------------------------------

ALL REFERENCES CONSIDERED EXCEPT WHERE LINED THROUGH. //I.O./

Printed: November 19, 2010 (12:45pm)

Path: Y:\Clients\SCOT Scott A Moskowitz and Wistaria Trading, Inc\SCOT0014-4\Drafts\IDS_SCOT00014-4_11-19-2010.wpd

37 CFR 1.98(a)(1)(i) APPLICATION:

37 CFR 1.98(a)(1)(iii): THIS IS AN INFORMATION DISCLOSURE STATEMENT

EXAMINER INITIALS	REF. NO. (L series)	REFERENCE NUMBER (L Series)	PUB. DATE	INCLUDE IN SEQUENCE: Name of first author (in CAPITAL LETTERS), Title in quotation marks, name of publication, date or publication, page numbers, publisher, city of publication, and country of publication NOTE - For US patent applications listed herein, if a publication of the application is identified, Applicant is citing the listed publication and not submitting a copy of the cited application as filed. The examiner is invited to inspect the IFW as desired to view any application as filed.	ENGLISH LANGUAGE TRANSLATION ATTACHED? (YES OR NO) AND/OR OR IDENTIFICATION OF PRIORITY APPLICATION IN WHICH REFERENCE IS CITED
	102	L- 0102		DUPLICATE OF L-22, DELETED BY RN UPON REVIEW ON 11/16/2010. RAN	
	103	L- 0103		DUPLICATE OF L-27, DELETED BY RN UPON REVIEW ON 11/16/2010. RAN	
	104	L- 0104	N/A	U.S. Appl. No. 60/234,199, filed Sep. 20, 2000, "Improved Security Based on Subliminal and Supraliminal Channels For Data Objects".	
	105	L- 0105	N/A	U.S. Appl. No. 09/671,739, filed Sep. 29, 2000, entitled "Method And Device For Monitoring And Analyzing Signals", abandoned.	
	106	L- 0106		DUPLICATE OF L-34, DELETED BY RN UPON REVIEW ON 11/16/2010. RAN	
	107	L- 0107		DUPLICATE OF L-24, DELETED BY RN UPON REVIEW ON 11/16/2010. RAN	
	108	L- 0108		DUPLICATE OF L-57, DELETED BY RN UPON REVIEW ON 11/16/2010. RAN	
	109	L- 0109		DUPLICATE OF L-58, DELETED BY RN UPON REVIEW ON 11/16/2010. RAN	

DATE: 03/17/2011	EXAMINER'S SIGNATURE: /Izunna Okeke/
------------------	--------------------------------------

ALL REFERENCES CONSIDERED EXCEPT WHERE LINED THROUGH. //I.O./

Printed: November 19, 2010 (12:45pm)

Path: Y:\Clients\SCOT Scott A Moskowitz and Wistaria Trading, Inc\SCOT0014-4\Drafts\IDS_SCOT00014-4_11-19-2010.wpd

37 CFR 1.98(a)(1)(i) APPLICATION:

37 CFR 1.98(a)(1)(iii): THIS IS AN INFORMATION DISCLOSURE STATEMENT

EXAMINER INITIALS	REF. NO. (L series)	REFERENCE NUMBER (L Series)	PUB. DATE	INCLUDE IN SEQUENCE: Name of first author (in CAPITAL LETTERS), Title in quotation marks, name of publication, date or publication, page numbers, publisher, city of publication, and country of publication NOTE - For US patent applications listed herein, if a publication of the application is identified, Applicant is citing the listed publication and not submitting a copy of the cited application as filed. The examiner is invited to inspect the IFW as desired to view any application as filed.	ENGLISH LANGUAGE TRANSLATION ATTACHED? (YES OR NO) AND/OR OR IDENTIFICATION OF PRIORITY APPLICATION IN WHICH REFERENCE IS CITED
	110	L- 0110		DUPLICATE OF L-59, DELETED BY RN UPON REVIEW ON 11/16/2010. RAN	
	111	L- 0111		DUPLICATE OF L-61, DELETED BY RN UPON REVIEW ON 11/16/2010. RAN	
	112	L- 0112		DUPLICATE OF L-62, DELETED BY RN UPON REVIEW ON 11/16/2010. RAN	
	113	L- 0113		DUPLICATE OF L-63, DELETED BY RN UPON REVIEW ON 11/16/2010. RAN	
	114	L- 0114		DUPLICATE OF L-65, DELETED BY RN UPON REVIEW ON 11/16/2010. RAN	
	115	L- 0115	Unknown	Tirkel, A.Z., "A Two-Dimensional Digital Watermark", Scientific Technology, 686, 14, date unknown. (citation revised upon review on 11/16/10 by RAN.)	
	116	L- 0116		DUPLICATE OF L-65, DELETED BY RN UPON REVIEW ON 11/16/2010. RAN	
	117	L- 0117		DUPLICATE OF L-68, DELETED BY RN UPON REVIEW ON 11/16/2010. RAN	
DATE: 03/17/2011			EXAMINER'S SIGNATURE: /Izunna Okeke/		

ALL REFERENCES CONSIDERED EXCEPT WHERE LINED THROUGH. //I.O./

Printed: November 19, 2010 (12:45pm)

Path: Y:\Clients\SCOT Scott A Moskowitz and Wistaria Trading, Inc\SCOT0014-4\Drafts\IDS_SCOT00014-4_11-19-2010.wpd

37 CFR 1.98(a)(1)(i) APPLICATION:

37 CFR 1.98(a)(1)(iii): THIS IS AN INFORMATION DISCLOSURE STATEMENT

EXAMINER INITIALS	REF. NO. (L series)	REFERENCE NUMBER (L Series)	PUB. DATE	INCLUDE IN SEQUENCE: Name of first author (in CAPITAL LETTERS), Title in quotation marks, name of publication, date or publication, page numbers, publisher, city of publication, and country of publication NOTE - For US patent applications listed herein, if a publication of the application is identified, Applicant is citing the listed publication and not submitting a copy of the cited application as filed. The examiner is invited to inspect the IFW as desired to view any application as filed.	ENGLISH LANGUAGE TRANSLATION ATTACHED? (YES OR NO) AND/OR OR IDENTIFICATION OF PRIORITY APPLICATION IN WHICH REFERENCE IS CITED
	118	L- 0118		DUPLICATE OF L-69, DELETED BY RN UPON REVIEW ON 11/16/2010. RAN	
	119	L- 0119		DUPLICATE OF L-70, DELETED BY RN UPON REVIEW ON 11/16/2010. RAN	
	120	L- 0120		DUPLICATE OF L-71, DELETED BY RN UPON REVIEW ON 11/16/2010. RAN	
	121	L- 0121		DUPLICATE OF L-72, DELETED BY RN UPON REVIEW ON 11/16/2010. RAN	
	122	L- 0122		DUPLICATE OF L-73, DELETED BY RN UPON REVIEW ON 11/16/2010. RAN	
	123	L- 0123		DUPLICATE OF L-74, DELETED BY RN UPON REVIEW ON 11/16/2010. RAN	
	124	L- 0124		DUPLICATE OF L-75, DELETED BY RN UPON REVIEW ON 11/16/2010. RAN	
	125	L- 0125		DUPLICATE OF L-076, REMOVED. RN. 11/16/2010	

DATE: 03/17/2011	EXAMINER'S SIGNATURE: /Izunna Okeke/
------------------	--------------------------------------

ALL REFERENCES CONSIDERED EXCEPT WHERE LINED THROUGH. //I.O./

Printed: November 19, 2010 (12:45pm)

Path: Y:\Clients\SCOT Scott A Moskowitz and Wistaria Trading, Inc\SCOT0014-4\Drafts\IDS_SCOT00014-4_11-19-2010.wpd

37 CFR 1.98(a)(1)(i) APPLICATION:

37 CFR 1.98(a)(1)(iii): THIS IS AN INFORMATION DISCLOSURE STATEMENT

EXAMINER INITIALS	REF. NO. (L series)	REFERENCE NUMBER (L Series)	PUB. DATE	INCLUDE IN SEQUENCE: Name of first author (in CAPITAL LETTERS), Title in quotation marks, name of publication, date or publication, page numbers, publisher, city of publication, and country of publication NOTE - For US patent applications listed herein, if a publication of the application is identified, Applicant is citing the listed publication and not submitting a copy of the cited application as filed. The examiner is invited to inspect the IFW as desired to view any application as filed.	ENGLISH LANGUAGE TRANSLATION ATTACHED? (YES OR NO) AND/OR OR IDENTIFICATION OF PRIORITY APPLICATION IN WHICH REFERENCE IS CITED
	126	L- 0126		DUPLICATE OF L-77, REMOVED. RN. 11/16/2010	
	127	L- 0127		DUPLICATE OF L-78, REMOVED. RN. 11/16/2010	
	128	L- 0128		DUPLICATE OF L-79, REMOVED. RN. 11/16/2010	
	129	L- 0129		EP0581317A2, MOVED TO FOREIGN PATENT PUBS as F-028	
	130	L- 0130		DUPLICATE OF L-52, REMOVED. RN. 11/16/2010	
	131	L- 0131		DUPLICATE OF L-36, REMOVED. RN. 11/16/2010	
	132	L- 0132		DUPLICATE OF L-38, REMOVED. RN. 11/16/2010.	
	133	L- 0133		DUPLICATE OF L-37, REMOVED. RN. 11/16/2010	

DATE: 03/17/2011	EXAMINER'S SIGNATURE: /Izunna Okeke/
------------------	--------------------------------------

ALL REFERENCES CONSIDERED EXCEPT WHERE LINED THROUGH. //I.O./

Printed: November 19, 2010 (12:45pm)

Path: Y:\Clients\SCOT Scott A Moskowitz and Wistaria Trading, Inc\SCOT0014-4\Drafts\IDS_SCOT00014-4_11-19-2010.wpd

37 CFR 1.98(a)(1)(i) APPLICATION:

37 CFR 1.98(a)(1)(iii): THIS IS AN INFORMATION DISCLOSURE STATEMENT

EXAMINER INITIALS	REF. NO. (L series)	REFERENCE NUMBER (L Series)	PUB. DATE	INCLUDE IN SEQUENCE: Name of first author (in CAPITAL LETTERS), Title in quotation marks, name of publication, date or publication, page numbers, publisher, city of publication, and country of publication NOTE - For US patent applications listed herein, if a publication of the application is identified, Applicant is citing the listed publication and not submitting a copy of the cited application as filed. The examiner is invited to inspect the IFW as desired to view any application as filed.	ENGLISH LANGUAGE TRANSLATION ATTACHED? (YES OR NO) AND/OR OR IDENTIFICATION OF PRIORITY APPLICATION IN WHICH REFERENCE IS CITED
	134	L- 0134		DUPLICATE OF L-36, REMOVED. RN. 11/16/2010	
	135	L- 0135		DUPLICATE OF L-37, REMOVED. RN. 11/16/2010	
	136	L- 0136		DUPLICATE OF L-38, REMOVED. RN. 11/16/2010	
	137	L- 0137		DUPLICATE OF L-39, REMOVED. RN. 11/16/2010	
	138	L- 0138		DUPLICATE OF L-40, REMOVED. RN. 11/16/2010	
	139	L- 0139		DUPLICATE OF L-41, REMOVED. RN. 11/16/2010	
	140	L- 0140		DUPLICATE OF L-42, REMOVED. RN. 11/16/2010	

DATE: 03/17/2011	EXAMINER'S SIGNATURE: /Izunna Okeke/
------------------	--------------------------------------

ALL REFERENCES CONSIDERED EXCEPT WHERE LINED THROUGH. //I.O./

Printed: November 19, 2010 (12:45pm)

Path: Y:\Clients\SCOT Scott A Moskowitz and Wistaria Trading, Inc\SCOT0014-4\Drafts\IDS_SCOT00014-4_11-19-2010.wpd

37 CFR 1.98(a)(1)(i) APPLICATION:

37 CFR 1.98(a)(1)(iii): THIS IS AN INFORMATION DISCLOSURE STATEMENT

EXAMINER INITIALS	REF. NO. (L series)	REFERENCE NUMBER (L Series)	PUB. DATE	INCLUDE IN SEQUENCE: Name of first author (in CAPITAL LETTERS), Title in quotation marks, name of publication, date or publication, page numbers, publisher, city of publication, and country of publication NOTE - For US patent applications listed herein, if a publication of the application is identified, Applicant is citing the listed publication and not submitting a copy of the cited application as filed. The examiner is invited to inspect the IFW as desired to view any application as filed.	ENGLISH LANGUAGE TRANSLATION ATTACHED? (YES OR NO) AND/OR OR IDENTIFICATION OF PRIORITY APPLICATION IN WHICH REFERENCE IS CITED
	141	L- 0141		DUPLICATE OF L-43, REMOVED. RN. 11/16/2010	
	142	L- 0142		DUPLICATE OF L-44, REMOVED. RN. 11/16/2010	
	143	L- 0143		DUPLICATE OF L-45, REMOVED. RN. 11/16/2010.	
	144	L- 0144		DUPLICATE OF L-46, REMOVED. RN. 11/16/2010.	
	145	L- 0145		DUPLICATE OF L-47, REMOVED. RN. 11/16/2010	
	146	L- 0146		DUPLICATE OF L-48, REMOVED. RN. 11/16/2010	
	147	L- 0147		DUPLICATE OF L-49, REMOVED. RN. 11/16/2010	

DATE: 03/17/2011	EXAMINER'S SIGNATURE: /Izunna Okeke/
------------------	--------------------------------------

ALL REFERENCES CONSIDERED EXCEPT WHERE LINED THROUGH. //I.O./

Printed: November 19, 2010 (12:45pm)

Path: Y:\Clients\SCOT Scott A Moskowitz and Wistaria Trading, Inc\SCOT0014-4\Drafts\IDS_SCOT00014-4_11-19-2010.wpd

37 CFR 1.98(a)(1)(i) APPLICATION:

37 CFR 1.98(a)(1)(iii): THIS IS AN INFORMATION DISCLOSURE STATEMENT

EXAMINER INITIALS	REF. NO. (L series)	REFERENCE NUMBER (L Series)	PUB. DATE	INCLUDE IN SEQUENCE: Name of first author (in CAPITAL LETTERS), Title in quotation marks, name of publication, date or publication, page numbers, publisher, city of publication, and country of publication NOTE - For US patent applications listed herein, if a publication of the application is identified, Applicant is citing the listed publication and not submitting a copy of the cited application as filed. The examiner is invited to inspect the IFW as desired to view any application as filed.	ENGLISH LANGUAGE TRANSLATION ATTACHED? (YES OR NO) AND/OR OR IDENTIFICATION OF PRIORITY APPLICATION IN WHICH REFERENCE IS CITED
	148	L- 0148		DUPLICATE OF L-50, REMOVED. RN. 11/16/2010	
	149	L- 0149		DUPLICATE OF L-51, REMOVED. RN. 11/16/2010	
	150	L- 0150		DUPLICATE OF L-52, REMOVED. RN. 11/16/2010	
	151	L- 0151		DUPLICATE OF L-63, REMOVED. RN. 11/16/2010	
	152	L- 0152		DUPLICATE OF L-54, REMOVED. RN. 11/16/2010	
	153	L- 0153		DUPLICATE OF L-55, REMOVED. RN. 11/16/2010.	
	154	L- 0154		DUPLICATE OF L-80, REMOVED. RN. 11/16/2010.	
	155	L- 0155	N/A	PCT International Search Report in PCT/US95/08159.	
	156	L- 0156	N/A	PCT International Search Report in PCT/US96/10257	
	157	L- 0157	N/A	Supplementary European Search Report in EP 96919405.	

DATE: 03/17/2011	EXAMINER'S SIGNATURE: /Izunna Okeke/
------------------	--------------------------------------

ALL REFERENCES CONSIDERED EXCEPT WHERE LINED THROUGH. //I.O./

Printed: November 19, 2010 (12:45pm)

Path: Y:\Clients\SCOT Scott A Moskowitz and Wistaria Trading, Inc\SCOT0014-4\Drafts\IDS_SCOT00014-4_11-19-2010.wpd

37 CFR 1.98(a)(1)(i) APPLICATION:

37 CFR 1.98(a)(1)(iii): THIS IS AN INFORMATION DISCLOSURE STATEMENT

EXAMINER INITIALS	REF. NO. (L series)	REFERENCE NUMBER (L Series)	PUB. DATE	INCLUDE IN SEQUENCE: Name of first author (in CAPITAL LETTERS), Title in quotation marks, name of publication, date or publication, page numbers, publisher, city of publication, and country of publication NOTE - For US patent applications listed herein, if a publication of the application is identified, Applicant is citing the listed publication and not submitting a copy of the cited application as filed. The examiner is invited to inspect the IFW as desired to view any application as filed.	ENGLISH LANGUAGE TRANSLATION ATTACHED? (YES OR NO) AND/OR OR IDENTIFICATION OF PRIORITY APPLICATION IN WHICH REFERENCE IS CITED
	158	L- 0158	N/A	PCT International Search Report in PCT/US97/00651.	
	159	L- 0159	N/A	PCT International Search Report in PCT/US97/00652	
	160	L- 0160	N/A	PCT International Search Report in PCT/US97/11455.	
	161	L- 0161	N/A	PCT International Search Report in PCT/US99/07262.	
	162	L- 0162	N/A	PCT International Search Report, completed Jun. 30, 2000; authorized officer Paul E. Callahan (PCT/US00/06522) (7 pages).	
	163	L- 0163	N/A	Supplementary European Search Report in EP00919398	
	164	L- 0164	N/A	PCT International Search Report in PCT/US00/18411.	
	165	L- 0165	N/A	PCT International Search Report in PCT/US00/18411.	
	166	L- 0166	N/A	PCT International Search Report in PCT/US00/33126	

DATE: 03/17/2011	EXAMINER'S SIGNATURE: /Izunna Okeke/
------------------	--------------------------------------

ALL REFERENCES CONSIDERED EXCEPT WHERE LINED THROUGH. //I.O./

Printed: November 19, 2010 (12:45pm)

Path: Y:\Clients\SCOT Scott A Moskowitz and Wistaria Trading, Inc\SCOT0014-4\Drafts\IDS_SCOT00014-4_11-19-2010.wpd

37 CFR 1.98(a)(1)(i) APPLICATION:

37 CFR 1.98(a)(1)(iii): THIS IS AN INFORMATION DISCLOSURE STATEMENT

EXAMINER INITIALS	REF. NO. (L series)	REFERENCE NUMBER (L Series)	PUB. DATE	INCLUDE IN SEQUENCE: Name of first author (in CAPITAL LETTERS), Title in quotation marks, name of publication, date or publication, page numbers, publisher, city of publication, and country of publication NOTE - For US patent applications listed herein, if a publication of the application is identified, Applicant is citing the listed publication and not submitting a copy of the cited application as filed. The examiner is invited to inspect the IFW as desired to view any application as filed.	ENGLISH LANGUAGE TRANSLATION ATTACHED? (YES OR NO) AND/OR OR IDENTIFICATION OF PRIORITY APPLICATION IN WHICH REFERENCE IS CITED
	167	L- 0167	N/A	PCT International Search Report in PCT/US00/21189	
	168	L- 0168	1996	Delaigle, J.-F., et al. "Digital Watermarking," Proceedings of the SPIE, vol. 2659, Feb 1, 1996, pp. 99-110.	
	169	L- 0169	1996	Schneider, M., et al. "A Robust Content Based Digital Signature for Image Authentication," Proceedings of the International Conference on Image Processing (IC. Lausanne) Sep. 16-19, 1996, pp. 227-230, IEEE ISBN.	
	170	L- 0170	1997	Cox, I. J., et al. "Secure Spread Spectrum Watermarking for Multimedia," IEEE Transactions on Image Processing, vol. 6 No. 12, Dec. 1, 1997, pp. 1673-1686.	
	171	L- 0171	1998	Wong, Ping Wah. "A Public Key Watermark for Image Verification and Authentication," IEEE International Conference on Image Processing, vol. 1 Oct. 4-7, 1998, pp. 455-459.	
	172	L- 0172	1998	Fabien A.P. Petitcolas, Ross J. Anderson and Markkus G. Kuhn, "Attacks on Copyright Marking Systems," LNCS, vol. 1525, Apr. 14-17, 1998, pp. 218-238 ISBN: 3-540-65386-4.	

DATE: 03/17/2011	EXAMINER'S SIGNATURE: /Izunna Okeke/
------------------	--------------------------------------

ALL REFERENCES CONSIDERED EXCEPT WHERE LINED THROUGH. //I.O./

Printed: November 19, 2010 (12:45pm)

Path: Y:\Clients\SCOT Scott A Moskowitz and Wistaria Trading, Inc\SCOT0014-4\Drafts\IDS_SCOT00014-4_11-19-2010.wpd

37 CFR 1.98(a)(1)(i) APPLICATION:

37 CFR 1.98(a)(1)(iii): THIS IS AN INFORMATION DISCLOSURE STATEMENT

EXAMINER INITIALS	REF. NO. (L series)	REFERENCE NUMBER (L Series)	PUB. DATE	INCLUDE IN SEQUENCE: Name of first author (in CAPITAL LETTERS), Title in quotation marks, name of publication, date or publication, page numbers, publisher, city of publication, and country of publication NOTE - For US patent applications listed herein, if a publication of the application is identified, Applicant is citing the listed publication and not submitting a copy of the cited application as filed. The examiner is invited to inspect the IFW as desired to view any application as filed.	ENGLISH LANGUAGE TRANSLATION ATTACHED? (YES OR NO) AND/OR OR IDENTIFICATION OF PRIORITY APPLICATION IN WHICH REFERENCE IS CITED
	173	L- 0173	1996	Ross Anderson, "Stretching the Limits of Steganography," LNCS, vol. 1174, May/Jun. 1996, 10 pages, ISBN: 3-540-61996-8.	
	174	L- 0174	1997	Joseph J.K. O'Ruanaidh and Thierry Pun, "Rotation, Scale and Translation Invariant Digital Image Watermarking", pre-publication, Summer 1997 4 pages.	
	175	L- 0175	1997	Joseph J.K. O'Ruanaidh and Thierry Pun, "Rotation, Scale and Translation Invariant Digital Image Watermarking", Submitted to Signal Processing Aug. 21, 1997, 19 pages.	
	176	L- 0176	2008	OASIS (Dig Out Your Soul), Big Brother Recordings Ltd, Promotional CD image, 2008, 1 page.	
	177	L- 0177	1998	Rivest, R. "Chaffing and Winnowing: Confidentiality without Encryption", MIT Lab for Computer Science, http://people.csail.mit.edu/rivest/Chaffing.txt Apr. 24, 1998, 9 pp.	
	178	L- 0178	2003	PortalPlayer, PP502 digital media management system-on-chip, May 1, 2003, 4 pp.	
	179	L- 0179	2001	VeriDisc, "The Search for a Rational Solution to Digital Rights Management (DRM)", http://64.244.235.240/news/whitepaper/docs/veridisc.sub.--white.sub.--paper.pdf , 2001, 15 pp.	

DATE: 03/17/2011	EXAMINER'S SIGNATURE: /Izunna Okeke/
------------------	--------------------------------------

ALL REFERENCES CONSIDERED EXCEPT WHERE LINED THROUGH. //I.O./

Printed: November 19, 2010 (12:45pm)

Path: Y:\Clients\SCOT Scott A Moskowitz and Wistaria Trading, Inc\SCOT0014-4\Drafts\IDS_SCOT00014-4_11-19-2010.wpd

37 CFR 1.98(a)(1)(i) APPLICATION:

37 CFR 1.98(a)(1)(iii): THIS IS AN INFORMATION DISCLOSURE STATEMENT

EXAMINER INITIALS	REF. NO. (L series)	REFERENCE NUMBER (L Series)	PUB. DATE	INCLUDE IN SEQUENCE: Name of first author (in CAPITAL LETTERS), Title in quotation marks, name of publication, date or publication, page numbers, publisher, city of publication, and country of publication NOTE - For US patent applications listed herein, if a publication of the application is identified, Applicant is citing the listed publication and not submitting a copy of the cited application as filed. The examiner is invited to inspect the IFW as desired to view any application as filed.	ENGLISH LANGUAGE TRANSLATION ATTACHED? (YES OR NO) AND/OR OR IDENTIFICATION OF PRIORITY APPLICATION IN WHICH REFERENCE IS CITED
	180	L- 0180	2008	Cayre, et al., "Kerckhoff's-Based Embedding Security Classes for WOA Data Hiding", IEEE Transactions on Information Forensics and Security, vol. 3 No. 1, Mar. 2008, 15 pp.	
	181	L- 0181	1999	Wayback Machine, dated Jan. 17, 1999, http://web.archive.org/web/19990117020420/http://www.netzero.com/ , accessed on Feb. 19, 2008.	
	182	L- 0182	1997	Namgoong, H., "An Integrated Approach to Legacy Data for Multimedia Applications", Proceedings of the 23rd EUROMICRO Conference, vol., Issue 1-4, Sep. 1997, pp. 387-391.	
	183	L- 0183	2007	Wayback Machine, dated Aug. 26, 2007, http://web.archive.org/web/20070826151732/http://www.screenplaysmag.com/t- abid/96/articleType/ArticleView/articleId/495/Default.aspx/ .	
	184	L- 0184	2009	"YouTube Copyright Policy: Video Identification tool--YouTube Help", accessed Jun. 4, 2009, http://www.google.com/support/youtube/bin/answer.py?hl=en&answer=83766 , 3 pp.	

DATE: 03/17/2011	EXAMINER'S SIGNATURE: /Izunna Okeke/
------------------	--------------------------------------

ALL REFERENCES CONSIDERED EXCEPT WHERE LINED THROUGH. //I.O./

Printed: November 19, 2010 (12:45pm)

Path: Y:\Clients\SCOT Scott A Moskowitz and Wistaria Trading, Inc\SCOT0014-4\Drafts\IDS_SCOT00014-4_11-19-2010.wpd

37 CFR 1.98(a)(1)(i) APPLICATION:

37 CFR 1.98(a)(1)(iii): THIS IS AN INFORMATION DISCLOSURE STATEMENT

EXAMINER INITIALS	REF. NO. (L series)	REFERENCE NUMBER (L Series)	PUB. DATE	INCLUDE IN SEQUENCE: Name of first author (in CAPITAL LETTERS), Title in quotation marks, name of publication, date or publication, page numbers, publisher, city of publication, and country of publication NOTE - For US patent applications listed herein, if a publication of the application is identified, Applicant is citing the listed publication and not submitting a copy of the cited application as filed. The examiner is invited to inspect the IFW as desired to view any application as filed.	ENGLISH LANGUAGE TRANSLATION ATTACHED? (YES OR NO) AND/OR OR IDENTIFICATION OF PRIORITY APPLICATION IN WHICH REFERENCE IS CITED
	185	L- 0185	N/A	U.S. Appl. No. 12/665,002, filed Dec. 22, 2009, entitled "Method for Combining Transfer Function with Predetermined Key Creation", published as 2010-0182570 A1 07-22-2010.	
	186	L- 0186	N/A	U.S. Appl. No. 12/592,331, filed Nov. 23, 2009, entitled "Optimization Methods for the Insertion, Protection, and Detection of Digital Watermarks in Digital Data", published as 2010-0077220 A1 03-25-2010.	
	187	L- 0187	N/A	U.S. Appl. No. 12/590,553, filed Nov. 10, 2009, entitled "Optimization Methods for the Insertion, Protection, and Detection of Digital Watermarks in Digital Data", published as 2010-0077219 A1 03-25-2010.	
	188	L- 0188	N/A	U.S. Appl. No. 12/590,681, filed Nov. 12, 2009, entitled "Optimization Methods for the Insertion, Protection, and Detection of Digital Watermarks in Digital Data", published as 2010-0064140 A1 03-11-2010.	
	189	L- 0189	N/A	U.S. Appl. No. 12/655,036, filed Dec. 22, 2009, entitled "Utilizing Data Reduction in Steganographic and Cryptographic Systems", published as 2010-0153734 A1 06-17-2010 .	
	190	L- 0190	N/A	U.S. Appl. No. 12/655,357, filed Dec. 22, 2009, entitled "Method And Device For Monitoring And Analyzing Signals", published as 2010-0106736 A1 04-29-2010.	

DATE: 03/17/2011	EXAMINER'S SIGNATURE: /Izunna Okeke/
------------------	--------------------------------------

ALL REFERENCES CONSIDERED EXCEPT WHERE LINED THROUGH. //I.O./

Printed: November 19, 2010 (12:45pm)

Path: Y:\Clients\SCOT Scott A Moskowitz and Wistaria Trading, Inc\SCOT0014-4\Drafts\IDS_SCOT00014-4_11-19-2010.wpd

37 CFR 1.98(a)(1)(i) APPLICATION:

37 CFR 1.98(a)(1)(iii): THIS IS AN INFORMATION DISCLOSURE STATEMENT

EXAMINER INITIALS	REF. NO. (L series)	REFERENCE NUMBER (L Series)	PUB. DATE	INCLUDE IN SEQUENCE: Name of first author (in CAPITAL LETTERS), Title in quotation marks, name of publication, date or publication, page numbers, publisher, city of publication, and country of publication NOTE - For US patent applications listed herein, if a publication of the application is identified, Applicant is citing the listed publication and not submitting a copy of the cited application as filed. The examiner is invited to inspect the IFW as desired to view any application as filed.	ENGLISH LANGUAGE TRANSLATION ATTACHED? (YES OR NO) AND/OR OR IDENTIFICATION OF PRIORITY APPLICATION IN WHICH REFERENCE IS CITED
	191	L- 0191	N/A	PCT Application No. PCT/US95/08159, filed Jun. 26, 1995, entitled, "Digital Information Commodities Exchange with Virtual Menuing", published as WO/1997/001892; Publication Date: 16.01.1997.	
	192	L- 0192	N/A	PCT Application No. PCT/US96/10257, filed Jun. 7, 1996, entitled "Steganographic Method and Device"--corresponding to--EPO Application No. 96919405.9, entitled "Steganographic Method and Device", published as WO/1996/042151; Publication Date: 27.12.1996.	
	193	L- 0193	N/A	PCT Application No. PCT/US97/00651, filed Jan. 16, 1997, entitled, "Method for Stega-Cipher Protection of Computer Code", published as WO/1997/026732; Publication Date: 24.07.1997.	
	194	L- 0194	N/A	PCT Application No. PCT/US97/00652, filed Jan. 17, 1997, entitled, "Method for an Encrypted Digital Watermark", published as WO/1997/026733; Publication Date: 24.07.1997	
	195	L- 0195	N/A	PCT Application No. PCT/US97/11455, filed Jul. 2, 1997, entitled, "Optimization Methods for the Insertion, Protection and Detection of Digital Watermarks in Digitized Data", published as WO/1998/002864; Publication Date: 22.01.1998	

DATE: 03/17/2011	EXAMINER'S SIGNATURE: /Izunna Okeke/
------------------	--------------------------------------

ALL REFERENCES CONSIDERED EXCEPT WHERE LINED THROUGH. //I.O./

Printed: November 19, 2010 (12:45pm)

Path: Y:\Clients\SCOT Scott A Moskowitz and Wistaria Trading, Inc\SCOT0014-4\Drafts\IDS_SCOT00014-4_11-19-2010.wpd

37 CFR 1.98(a)(1)(i) APPLICATION:

37 CFR 1.98(a)(1)(iii): THIS IS AN INFORMATION DISCLOSURE STATEMENT

EXAMINER INITIALS	REF. NO. (L series)	REFERENCE NUMBER (L Series)	PUB. DATE	INCLUDE IN SEQUENCE: Name of first author (in CAPITAL LETTERS), Title in quotation marks, name of publication, date or publication, page numbers, publisher, city of publication, and country of publication NOTE - For US patent applications listed herein, if a publication of the application is identified, Applicant is citing the listed publication and not submitting a copy of the cited application as filed. The examiner is invited to inspect the IFW as desired to view any application as filed.	ENGLISH LANGUAGE TRANSLATION ATTACHED? (YES OR NO) AND/OR OR IDENTIFICATION OF PRIORITY APPLICATION IN WHICH REFERENCE IS CITED
	196	L- 0196	N/A	PCT Application No. PCT/US99/07262, filed Apr. 2, 1999, entitled, "Multiple Transform Utilization and Applications for Secure Digital Watermarking", published as WO/1999/052271; Publication Date: 14.10.1999.	
	197	L- 0197	N/A	PCT Application No. PCT/US00/06522, filed Mar. 14, 2000, entitled, "Utilizing Data Reduction in Steganographic and Cryptographic Systems", published as WO/2000/057643; Publication Date: 28.09.2000.	
	198	L- 0198	N/A	PCT Application No. PCT/US00/18411, filed Jul. 5, 2000, entitled, "Copy Protection of Digital Data Combining Steganographic and Cryptographic Techniques"--corresponding to AU200060709A5 (not available).	
	199	L- 0199	N/A	PCT Application No. PCT/US00/33126, filed Dec. 7, 2000, entitled "Systems, Methods and Devices for Trusted Transactions", published as WO/2001/043026; Publication Date: 14.06.2001.	
	200	L- 0200	N/A	EPO Divisional Patent Application No. 07112420.0, entitled "Steganographic Method and Device" corresponding to PCT Application No. PCT/US96/10257, cited herein above as L-192.	

DATE: 03/17/2011	EXAMINER'S SIGNATURE: /Izunna Okeke/
------------------	--------------------------------------

ALL REFERENCES CONSIDERED EXCEPT WHERE LINED THROUGH. //I.O./

Printed: November 19, 2010 (12:45pm)

Path: Y:\Clients\SCOT Scott A Moskowitz and Wistaria Trading, Inc\SCOT0014-4\Drafts\IDS_SCOT00014-4_11-19-2010.wpd

37 CFR 1.98(a)(1)(i) APPLICATION:

37 CFR 1.98(a)(1)(iii): THIS IS AN INFORMATION DISCLOSURE STATEMENT

EXAMINER INITIALS	REF. NO. (L series)	REFERENCE NUMBER (L Series)	PUB. DATE	INCLUDE IN SEQUENCE: Name of first author (in CAPITAL LETTERS), Title in quotation marks, name of publication, date or publication, page numbers, publisher, city of publication, and country of publication NOTE - For US patent applications listed herein, if a publication of the application is identified, Applicant is citing the listed publication and not submitting a copy of the cited application as filed. The examiner is invited to inspect the IFW as desired to view any application as filed.	ENGLISH LANGUAGE TRANSLATION ATTACHED? (YES OR NO) AND/OR OR IDENTIFICATION OF PRIORITY APPLICATION IN WHICH REFERENCE IS CITED
	201	L- 0201	N/A	US Provisional Application 60/222,023 filed July 31, 2007 entitled "Method and apparatus for recognizing sound and signals in high noise and distortion"	
	202	L- 0202	N/A	US Application 11/458,639 filed July 19, 2006 entitled "Methods and Systems for Inserting Watermarks in Digital Signals", published as 2006-0251291 A1 11-09-2006.	
	203	L- 0203	1995	"Techniques for Data Hiding in Audio Files," by Morimoto, 1995	
	204	L- 0204	1998	Howe, Dennis July 13, 1998 http://foldoc.org/steganography	
	205	L- 0205	N/A	CSG, Computer Support Group and CSGNetwork.com 1973 http://www.csgnetwork.com/glossarys.html	
	206	L- 0206	2010	QuinStreet Inc. 2010 What is steganography?-A word definition from the Webopedia Computer Dictionary http://www.webopedia.com/terms/steganography.html	
	207	L- 0207	2000	Graham, Robert August 21, 2000 "Hacking Lexicon" http://robertgraham.com/pubs/hacking-dict.html	

DATE: 03/17/2011	EXAMINER'S SIGNATURE: /Izunna Okeke/
------------------	--------------------------------------

ALL REFERENCES CONSIDERED EXCEPT WHERE LINED THROUGH. //I.O./

Printed: November 19, 2010 (12:45pm)

Path: Y:\Clients\SCOT Scott A Moskowitz and Wistaria Trading, Inc\SCOT0014-4\Drafts\IDS_SCOT00014-4_11-19-2010.wpd

37 CFR 1.98(a)(1)(i) APPLICATION:

37 CFR 1.98(a)(1)(iii): THIS IS AN INFORMATION DISCLOSURE STATEMENT

EXAMINER INITIALS	REF. NO. (L series)	REFERENCE NUMBER (L Series)	PUB. DATE	INCLUDE IN SEQUENCE: Name of first author (in CAPITAL LETTERS), Title in quotation marks, name of publication, date or publication, page numbers, publisher, city of publication, and country of publication NOTE - For US patent applications listed herein, if a publication of the application is identified, Applicant is citing the listed publication and not submitting a copy of the cited application as filed. The examiner is invited to inspect the IFW as desired to view any application as filed.	ENGLISH LANGUAGE TRANSLATION ATTACHED? (YES OR NO) AND/OR OR IDENTIFICATION OF PRIORITY APPLICATION IN WHICH REFERENCE IS CITED
	208	L- 0208	2010	Farxex, Inc 2010 "Steganography definition of steganography in the Free Online Encyclopedia" http://encyclopedia2.Thefreedictionary.com/steganography	
	209	L- 0209	1989	Horowitz, et al., The Art of Eletronics. 2 nd Ed., 1989, pp7	
	210	L- 0210	2004	Jimmy eat world ("futures"), Interscope Records, Pre-Release CD image, 2004, 1 page.	
	211	L- 0211	2001	Aerosmith ("Just Push Play"), Pre-Release CD image, 2001, 1 page.	
	212	L- 0212	2002	Phil Collins(Testify) Atlantic, Pre-Release CD image, 2002, 1 page.	

ran

Date/time code: November 19, 2010 (12:45pm)

Y:\Clients\SCOT Scott A Moskowitz and Wistaria Trading, Inc\SCOT0014-4\Drafts\IDS_SCOT00014-4_11-19-2010.wpd

DATE: 03/17/2011	EXAMINER'S SIGNATURE: /Izunna Okeke/
------------------	--------------------------------------

ALL REFERENCES CONSIDERED EXCEPT WHERE LINED THROUGH. //I.O./

Receipt date: 11/19/2010

11895388 - GAU: 2432

Printed: November 19, 2010 (12:45pm)

Path: Y:\Clients\SCOT Scott A Moskowitz and Wistaria Trading,
Inc\SCOT0014-4\Drafts\IDS_SCOT00014-4_11-19-2010.wpd

37 CFR 1.98(a)(1)(i) APPLICATION:

37 CFR 1.98(a)(1)(iii): THIS IS AN INFORMATION DISCLOSURE STATEMENT

DATE: 03/17/2011	EXAMINER'S SIGNATURE: /Izunna Okeke/
------------------	--------------------------------------

Page 61 of 61

ALL REFERENCES CONSIDERED EXCEPT WHERE LINED THROUGH. //I.O./

Neifeld Docket No: SCOT0014-4

Application/Patent No: 11/895,388

USPTO CONFIRMATION NO: 2103

File/Issue Date: 8/24/2007

Inventor/title: Moskowitz/ Data protection method and device

Examiner/ArtUnit: Izunna OKEKE/2432

ENTITY STATUS: SMALL (CONVERT UPON ALLOWANCE TO LARGE)

Priority: Application No. 09/046,627 (which issued July 22, 2003, as U.S. Patent No. 6,598,162)

**37 CFR 1.7(c) FILING RECEIPT AND TRANSMITTAL LETTER WITH
AUTHORIZATION TO CHARGE DEPOSIT ACCOUNT**

1. **THE COMMISSIONER IS HEREBY AUTHORIZED TO CHARGE ANY FEES WHICH MAY BE REQUIRED, OR CREDIT ANY OVERPAYMENT, TO DEPOSIT ACCOUNT NUMBER 50-2106.**

2. **FEES (PAID HEREWITH BY EFS CREDIT CARD SUBMISSION) \$ 0**

A. **CLAIMS FEES**

B. **OTHER FEES**

3. **THE FOLLOWING DOCUMENTS ARE SUBMITTED HEREWITH:**
STATEMENT OF SUMMARY OF INTERVIEW

4. **FOR INTERNAL NEIFELD IP LAW, PC USE ONLY**

acct/ck/No/date/amnt: 6/

Firm charge:

INITIALS OF PERSON WHO **ENTERED** ACCOUNTING DATA: RAN

ATTORNEY SIGNATURE (AUTHORIZING DEPOSIT ACCOUNT)

4/19/2011

/RichardNeifeld#35,299/

RICHARD NEIFELD, REG. NO. 35,299

ATTORNEY OF RECORD

Printed: April 19, 2011 (5:56pm)

Y:\Clients\SCOT Scott A Moskowitz and Wistaria Trading,

Inc\SCOT0014-4\Drafts\SummaryOfInterview_SCOT0014-4_4-19-2011.wpd

STATEMENT OF SUMMARY OF INTERVIEW

The 3/18/2011 Interview Summary states that "Applicant's representative discussed claim 32 with reference to the applied reference and explained that the reference fails to teach a watermark which encodes a license code. As applicant has already filed an After Final amendment, examiner noted applicant's argument and would respond to the AF appropriately." and the Interview Summary required me to file a Statement of the Substance of the Interview. Accordingly, my statement of the substance of the interview is what is stated in the 3/18/2011 Interview Summary quoted above.

4/19/2011 /RichardNeifeld#35,299/
RICHARD NEIFELD, REG. NO. 35,299
ATTORNEY OF RECORD

RAN
Date/Time code: April 19, 2011 (5:56pm)
Y:\Clients\SCOT Scott A Moskowitz and Wistaria Trading,
Inc\SCOT0014-4\Drafts\SummaryOfInterview_SCOT0014-4_4-19-2011.wpd

Electronic Acknowledgement Receipt

EFS ID:	9913651
Application Number:	11895388
International Application Number:	
Confirmation Number:	2103
Title of Invention:	Data protection method and device
First Named Inventor/Applicant Name:	Scott A. Moskowitz
Customer Number:	31518
Filer:	Richard A. Neifeld
Filer Authorized By:	
Attorney Docket Number:	SCOT0014-4
Receipt Date:	19-APR-2011
Filing Date:	24-AUG-2007
Time Stamp:	17:59:30
Application Type:	Utility under 35 USC 111(a)

Payment information:

Submitted with Payment	no
------------------------	----

File Listing:

Document Number	Document Description	File Name	File Size(Bytes)/ Message Digest	Multi Part /.zip	Pages (if appl.)
1	Miscellaneous Incoming Letter	SummaryOfInterview_SCOT0014-4_4-19-2011.pdf	36969 fc9a869704d1d6805d04df9ed69c644c528a1462	no	2

Warnings:

Information:

This Acknowledgement Receipt evidences receipt on the noted date by the USPTO of the indicated documents, characterized by the applicant, and including page counts, where applicable. It serves as evidence of receipt similar to a Post Card, as described in MPEP 503.

New Applications Under 35 U.S.C. 111

If a new application is being filed and the application includes the necessary components for a filing date (see 37 CFR 1.53(b)-(d) and MPEP 506), a Filing Receipt (37 CFR 1.54) will be issued in due course and the date shown on this Acknowledgement Receipt will establish the filing date of the application.

National Stage of an International Application under 35 U.S.C. 371

If a timely submission to enter the national stage of an international application is compliant with the conditions of 35 U.S.C. 371 and other applicable requirements a Form PCT/DO/EO/903 indicating acceptance of the application as a national stage submission under 35 U.S.C. 371 will be issued in addition to the Filing Receipt, in due course.

New International Application Filed with the USPTO as a Receiving Office

If a new international application is being filed and the international application includes the necessary components for an international filing date (see PCT Article 11 and MPEP 1810), a Notification of the International Application Number and of the International Filing Date (Form PCT/RO/105) will be issued in due course, subject to prescriptions concerning national security, and the date shown on this Acknowledgement Receipt will establish the international filing date of the application.

Neifeld Docket No: SCOT0014-4

Application/Patent No: 11/895,388

USPTO CONFIRMATION NO: 2103

File/Issue Date: 8/24/2007

Inventor/title: Moskowitz/ Data protection method and device

Examiner/ArtUnit: Izunna OKEKE/2432

ENTITY STATUS: SMALL (CONVERT UPON ALLOWANCE TO LARGE)

Priority: Application No. 09/046,627 (which issued July 22, 2003, as U.S. Patent No. 6,598,162)

**37 CFR 1.7(c) FILING RECEIPT AND TRANSMITTAL LETTER WITH
AUTHORIZATION TO CHARGE DEPOSIT ACCOUNT**

1. **THE COMMISSIONER IS HEREBY AUTHORIZED TO CHARGE ANY FEES WHICH MAY BE REQUIRED, OR CREDIT ANY OVERPAYMENT, TO DEPOSIT ACCOUNT NUMBER 50-2106.**

2. **FEES (PAID HEREWITH BY EFS CREDIT CARD SUBMISSION) \$ 0**

A. **CLAIMS FEES**

B. **OTHER FEES**

3. **THE FOLLOWING DOCUMENTS ARE SUBMITTED HEREWITH:**

CLAIMS

REMARKS

4. **FOR INTERNAL NEIFELD IP LAW, PC USE ONLY**

acct/ck/No/date/amnt: 6/

Firm charge:

INITIALS OF PERSON WHO **ENTERED** ACCOUNTING DATA: RAN

ATTORNEY SIGNATURE (AUTHORIZING DEPOSIT ACCOUNT)

6/30/2011

/RichardNeifeld#35,299/

RICHARD NEIFELD, REG. NO. 35,299

ATTORNEY OF RECORD

Printed: July 1, 2011 (12:17pm)

Y:\Clients\SCOT Scott A Moskowitz and Wistaria Trading,

Inc\SCOT0014-4\Drafts\Amendment_SCOT0014-4_6-30-2011.wpd

SUMMARY

This is a response to the non final office action (OA) dated 4-1-2011. The undersigned called and left a vm for Examiner Okeke on 6/30/2011 in order to discuss this case. The examiner is requested to telephone me if there remains any reason not to pass this application to issue.

OA item 1 notes that the prior rejections were withdrawn and comments on interpretation of Houser, USP 5606609 and the claim recitation "interrelationships". OA items 2-3 rejection claims 62-64 under 112, first paragraph, as failing to comply with the written description requirement. OA items 4-5 reject claim 37 under 112, second paragraph for lack of sufficient antecedent. OA items 6-7 reject claims 32-45 and 52-64 under 103(a) based upon Holmes, USP 5287407 and Houser, USP 5606609.

In response to OA item 1, the applicant appreciates examiner Okeke clarifying his interpretation.

In response to OA items 2-3, the applicant traverses for the reasons explained below.

In response to items 4-5, the applicant amends to correct the antecedent basis.

In response to items 6-7, the applicant traverses for the reasons explained below.

CLAIMS 62-64 UNDER 112, FIRST PARAGRAPH

OA items 2-3 states, regarding claim 62, that:

Claims 62 recites in part "wherein said software code defines software code interrelationships between code resources" and "to form a first license key encoded software code in which at least one of said software code interrelationship are encoded". The specification provides no support for this limitation as it fails to teach or mention "software code interrelationships", how the software code defines interrelationships between code resources and how it is encoded to form a first license key encoded software code. Applicant is asked to identify the section of the specification that provides support for claim 62.

With all due respect, this rejection is improper because it is inconsistent with binding precedent in view of the definition of the word "interrelationship" and the disclosure in our specification, as explained below. In fact, claim 62 reads:

62. (Previously Presented) A method for encoding software code using a computer having a processor and memory, comprising:
storing a software code in said memory;
wherein said software code defines software code interrelationships between code resources that result in a specified underlying functionality when installed on a computer system;
and
encoding, by said computer using at least a first license key and an encoding algorithm, said software code, to form a first license key encoded software code in which at least one of said software code interrelationships are encoded.

The test for written description was recently restated by the en banc court in Ariad, as follows (internal citation omitted):

Specifically, the description must "clearly allow persons of ordinary skill in the art to recognize that [the inventor] invented what is claimed." ... In other words, the test for sufficiency is whether the disclosure of the application relied upon reasonably conveys to those skilled in the art that the inventor had possession of the claimed subject matter as of the filing date. ... the test requires an objective inquiry into the four corners of the specification from the perspective of a person of ordinary skill in the art. Based on that inquiry, the specification must describe an invention understandable to that skilled artisan

And, it is black letter law, that "It is not required that the application describe the claim limitations in greater detail than the invention warrants or that the specification contain that which is known to those skilled in the art." Lindemann Maschinenfabrik GMBH v. American Hoist & Derrick Co., 730 F.2d 1452, 1463, 221 USPQ 481, 489 (Fed. Cir. 1984).

However, the rejection is based upon an alleged failure to disclose that which is admittedly known in the art, specifically, "software code interrelationships". That is not consistent with Lindemann Maschinenfabrik GMBH, supra.

Moreover, our specification does disclose software code interrelationships explaining to one skilled in the art (who admittedly already knew what such relationships were), in passing, as part of the background definition of the state of the art, thereby indicating that we knew what such interrelationships represented. Thus, our specification clearly meets the test to show that we were in possession of the concept of "software code interrelationships," which we use as a basis to explain novel concepts of our invention.

The phrase "code resources" apparently was not of concern to the examiner. However, that is very relevant to the "interrelationships" recitation. Claim 62 defines the software code interrelationships between "code resources". Our specification clearly defines "code resources" for example in published paragraphs [0051] and [0052]. The examiner questions whether the disclosure conveys to one skilled in the art that the inventor was in possession of the concept of "interrelationships" between code resources. However, paragraph [0051] goes into great detail in explaining how an "executable computer program" also referred to as an "application" and also referred to as an "executable code object," comprises "portions of object code [that] correspond with the programmers' function or procedure implementations in higher level languages" and that the "exact order or arrangement in memory is not important, so long as any sub-object [of an application] which uses another sub-object knows where in memory it can be found." Clearly, the knowledge of a first sub-object, of where another second sub-object that is used by the first sub-object is located in memory, is an interrelationship. After all, the definition of "interrelationship" is "the way in which two or more things affect each other because they are related in some way". See for example the online definition at the URL <http://www.onelook.com/?w=interrelationship&ls=a>.

As explained in the first sentence of the very next paragraph, [0052], "The memory address of the first instruction in one of these sub-objects is called the "entry point" of the function or procedure." and the " rest of the instructions comprising that sub-object immediately

follow from the entry point," which would indicate to anyone skilled in the art that the code object contained a reference to another code object, via some type of memory location identifier. Accordingly, anyone skilled in the art would clearly understand that the inventor had invented code resources that had interrelationships. In fact, it is surprising to the applicant that the examiner would object this language, because such interrelationships between code resources are not that which is novel. What the examiner has implied by alleging that the "specification ... fails to teach or mention 'software code interrelationships'" is that software code interrelationships were somehow unknown in the art, which clearly is not the case. As admitted, in the specification at the beginning of paragraph [0051], an "application" comprises "sub-objects" whose "order in the computer memory is of vital importance" in order to perform an intended function. And as admitted further in paragraph [0051], "When a program is compiled, then, it consists of a collection of these sub-objects, whose exact order or arrangement in memory is not important, so long as any sub-object which uses another sub-object knows where in memory it can be found." Paragraph [0051] of course refers to conventional applications. Accordingly, that is admittedly a *discussion of what is already known by one skilled in the art*. Accordingly, the examiner's statement that the specification lacks written description support for "software code interrelationships" is inconsistent with the fact that such interrelationships were explained in paragraphs [0051] and [0052] as a fundamental basis of pre-existing modern computer programs. Accordingly, the written description rejection, insofar as it is based upon the specification allegedly, failing to "teach or mention 'software code interrelationships'" is factually inconsistent with the specification, with the definition of the word "interrelationship," and with judicial precedent. As an aside, we note that fact that there is no *ipsis verbis* recitation "interrelationship" in the specification, is legally insufficient to form a basis for written description rejection. See *In re Edwards*, 568 F.2d 1349, 196 USPQ 465, 469 (CCPA 1978). Thus, it seems perfectly clear that "The specification [does] provide[... [written descriptive] support for this limitation [sic; software code interrelationships]". It clearly conveys to one skilled in the art that we knew what such interrelationships were. *Ariad*, *supra*.

The OA is also unclear in this rejection. It appears to suggest that the specification "fails to teach or mention ... how it [sic] is encoded to form a first license key encoded software code." Exactly what this assertion means is ambiguous and unclear because there is no clear antecedent for "it".

However, the claim's encoding recitation reads "encoding, by said computer using at least a first license key and an encoding algorithm, said software code, to form a first license key encoded software code in which at least one of said software code interrelationships are encoded." This recitation clearly defines encoding said software code using the first license key and the encoding algorithm. Encoding using a key and an algorithm is known, and therefore we surmise that encoding per se is not what the examiner believes to lack written description. *Lindemann Maschinenfabrik GMBH*, *supra*.

That leaves, as a possible basis for the "it" reference in the written description rejection, the claim recitation "at least one of said software code interrelationships are encoded." It is however unclear why the examiner would consider this recitation to lack written description because an interrelationship in software code is necessarily defined by digital data, and digital data can obviously be encoded by an encoding process. Accordingly, what further basis might exist for a conclusion that one skilled in the art reading the specification would not recognize

that the inventor had invented what is claimed, is unclear. Accordingly, the applicant believes that the written description rejection of claim 62 is misguided, inconsistent with the standard for written description, inconsistent with the meaning of the words and the claim, and inconsistent with the clear teachings in the specification.

Regarding claims 63 and 64, the OA states that:

Claim 63 and dependent claim 64 recites in part "encoding, by said computer using at least a first license key and an encoding algorithm, said software code, to form a second license key encoded software code; wherein said first license key encoded software code is not identical to said second license key encoded software code". There is also no disclosure that supports this limitation in the specification. There is no disclosure of using a "second license key" to encode a software code to form a "second license key encoded software code" wherein a first license key encoded software code is not identical to a second license key encoded software code. Applicant is also asked to point out the section of the specification that clearly provides support for claims 63 and 64.

In fact, claims 63 and 64 recite:

63. (Previously Presented) A method for encoding software code using a computer having a processor and memory, comprising:
storing a software code in said memory;
wherein said software code provides a specified underlying functionality when installed on a computer system;
encoding, by said computer using at least a first license key and an encoding algorithm, said software code, to form a first license key encoded software code;
encoding, by said computer using at least a second license key and an encoding algorithm, said software code, to form a second license key encoded software code;
wherein said first license key encoded software code is not identical to said second license key encoded software code if said first license key is not identical to said second license key.
64. (Previously Presented) The method of claim 63 wherein both said first license key encoded software code and said second license key encoded software code are capable of providing said specified underlying functionality when installed on a computer system.

The applicant respectfully traverses. This is because we disagree with the assertion that there "is no disclosure of using a 'second license key' to encode a software code to form a 'second license key encoded software code' wherein a first license key encoded software code is not identical to a second license key encoded software code." In fact, there is such disclosure.

At least one advantage identified by the disclosure is the ability to generate versions of software that are different from one another resulting from encoding with different keys, but provide the same user functionality when their respective keys are read. See for example, paragraph [0056], which explains that for each "key" used in encoding, the result of the encoding

method "a particular licensed copy of an application distinguishable from any other.". And that "The key is necessary to access the underlying code, i.e., what the user understands to be the application program." That theme runs through the background of the invention section, as well. As noted in paragraph [0017]-[0020], in one aspect, it is ownership information which is inserted via a digital watermark, and of course each owner of a software license is different from other such owners. Similarly, in the detailed description section, [0037] explains that the key is "randomly generated" and [0038] explains that "The key is necessary both to register the sought-after content and to descramble the content into its original form." Of course what this means is that each encoding with a different key results in a different digital object, referred to in claims 63 and 64 as non identical first and second "license key encoded software code". Accordingly, clear written description support exists in the specification for these claims.

CLAIM 37 UNDER 112, SECOND PARAGRAPH

In response to OA items 4-5, we amend claim 37 to depend from claim 35. Claim 35 recites "a key" and therefore provides sufficient antecedent for claim 37's "said key".

CLAIMS 32-45 AND 52-64 UNDER 103(A) BASED UPON HOLMES, USP 5287407 AND HOUSER, USP 5606609.

In response OA items 6-7, we respectfully traverse because Holmes and Houser do not suggest our claimed invention. In fact, Holmes is not relevant.

Regarding claim 32, note that the specification indicates that a particular license code is what is required to be input into a system running a particular software object encoded with a key corresponding to that license code, in order to allow the system to use the functionality of the software. See [0056]-[0057]. Claim 32 defines, in relevant part, a *method of modifying software*. As claimed, this method comprises "embedding a watermark *into said software*, using said computer, *said watermark encoding at least one first license code*, thereby resulting in a first license code encoded watermarked software".

In rejecting claim 32, the OA states that Holmes teaches embedding in software a "unique identifying data" that is "associated with a user or the system or the software." The OA also assumes that this embedded identifying data that "could serve as a license for the software." The OA does not assert any reference teaches using the embedded identifying data as a license for the software. The OA does not assert Holmes teaches entering the identifying data into a system in order to use the functionality of software.

What Holmes actually teaches is clear from its abstract, which states that: "A master copy of a software file has within it a predetermined block of data. When a copy of the file is made that block of data within the copied file is located and overwritten with data identifying the copied file. When an unauthorized copy is found, the data identifying the copy can be read and the source of the unauthorized copy may be traced." Holmes clearly distinguishes data from code, and discloses, only, inserting data identifying the copied file into "predetermined block of data". Holmes does not disclose modifying software code, only changing data in a data block of a "file". This data "block" means a sequential set of values. Cf. description of Fig. 1, "block 8 contains a predetermined sequence of code, in this example represented by `AAAAAA`."

Holmes teaches embedding in a data *file*, or a software *file* a unique identifying data that is associated with a user or the system or the software. (Holmes states " However, in preferred

embodiments of the invention said data identifying said copy file includes one or more items of data identifying the time at which said copy file was made, the authorized user of said copy file, said first data processing system and/or said second data processing system.")

The applicant notes that Holmes contain no mention of license, activation, or the like, relating to license codes for software. Holmes does not suggest that its embedded identifying data "could serve as a license for the software." Moreover, Holmes teaches away from that concept by going out of its way to point out that presence or absence of the predetermined block of data in a software file does not affect its functionality:

Another advantage of the system is that a software file may be produced by a software vendor to include the predetermined block of data, but use of that file will not require use of the technique of the invention. Accordingly, the same software file can be used in systems which do or do not implement the invention. The particular combination of elements comprising the invention provides a security technique which is surprisingly simple to implement and effective in use. ... Furthermore, producers of software files can include within them the necessary predetermined block of data which can be used to mark files distributed within the network, and yet, if desired, the same version of the software file can be copied and distributed by conventional techniques without using the invention.

The way Holmes accomplishes this is by *predetermining the location of the data block in its file*, and then only overwriting data *in that location in the file* with data unique to each copy, as stated in the description of its Figure 1, noting the reference to "*in the same position*":

FIG. 1 shows a master file 6 stored within a first data processing system 2. The master file 6 has embedded somewhere within it a predetermined block of data 8. The block 8 does not play any part in the function of the software of the master file itself; rather its function is to provide a locatable space within the master file in which data identifying a copied file may be written. The block 8 contains a predetermined sequence of code, in this example represented by `AAAAAA`.

A copy of the master file 6 is then transmitted to a second data processing system 4 which stores it as copied file 10. The block 8 is copied with the rest of the master file 6 and so the copied file 10 also contains a block 8 *in the same position* as the block 8 within the master file 6.

Thus, all Holmes teaches is encoding a data block at a predetermined location in any file, with data unique to each copy. Whether the rest of the file is software or data is irrelevant, because this predetermined location is functionally disconnected from the surrounding locations in the same file, whether they are data or software.

In rejecting claim 32, the OA assumes that Houser suggests modifying Holmes to embed identification data as a watermark. *However, Holmes specifically teaches containing the identifying data to a predetermined location in a file*, that is relative for example to the location of the start of the file.

Modifying Holmes to place a "watermark" in that predetermined location in the file is not what claim 32 defines. First, claim 32 recites "A computer-based method for *modifying software*". While Holmes teaches modifying a *file* containing software by changing non functional identifying data contained in the *file*, Holmes does not teach modifying the underlying functionality of the software. Claim 32's preamble does.

Assuming the OA suggests modifying Holmes in view of Houser to move the identifying data from its predetermined location to unspecified locations, there is no legal motivation to do that, for two reasons.

First, as already noted, such a modification would destroy the only utility that Holmes provides, which is to allow for identification of a file without affecting the data or code otherwise contained in the file. Replacing the predetermined location identifying data in Holmes with a watermark distributed elsewhere in the Holmes data file other than in just the predetermined location, would preclude the easy identification noted in Holmes.

Second, replacing the predetermined location identifying data in Holmes with a watermark distributed elsewhere in the Holmes data file other than in just the predetermined location, lacking the teachings of our invention, would also fatally affect functionality of any software elements contained in the modified file. This is because such a watermarking would change the intra-relationships in, as well as the inter-relationships between, code elements of software in the file. First, the watermarking of Holmes file, if present outside of the predetermined location, would introduce random values at locations inside of what we refer to as "code elements", those sets of instructions for a function, for which we teach such random values would "very likely to 'break' the function" [[0057]. Destroying intra-relationships. This would destroy the functionality of the software. Second, the watermarking would also change the inter-relationships of relative memory location between distinct code elements, thereby prevent them from function as intended because their relative memory locations would change in a manner not accounted for by each code resource. That would defeat the purpose of Holmes of preserving (data values in a pure data file or) software functionality, in a file otherwise identified by Holmes identity data.

And there is nothing in either Holmes or Houser suggesting, as is taught in the present application, how to watermark throughout a software application, without destroying the functionality of the underlying application. Accordingly, there is no motivation to modify Holmes in view of Houser. We note that, in contrast, as explained above, we do teach an encoding that does not destroy the fundamental code resources by not changing code resources, during encoding.

The rejections of all claims is based upon the flawed combination of Holmes and Houser. Insofar as the foregoing explanation unequivocally shows that the rejection of all claims is improper, no further arguments need be presented. However, it is likely that all additional basis for rejection for obviousness also contain additional flaws, given the fundamental flaws in the base reasoning just described.

REPOSE

Finally, the applicant notes that this is the third office action containing rejections based upon substantive examination of the claims. Each office action has shifted focus of rejections: from double patenting over 08587943 and 102 rejection over Moore in the first office action; to

double patenting over 5,745,569 and 102 rejection based upon Houser in the second office action; to 103 rejection based upon Holmes in the present office action. We respectfully submit that this case has undergone sufficient examination and no more new rejections are warranted. The invention as disclosed and claimed is novel and very inventive, and whatever minor technical problems the examiners might consider remain, should not form a basis for further delays in issuance. Three substantive examinations, all successfully traversed, are more than sufficient, and therefore indicate time for repose. This application should now be passed to issue.

Truly, /Richard Neifeld/
RICHARD NEIFELD, REG. NO. 35,299
ATTORNEY OF RECORD

ran

Date/TimeCode: July 1, 2011 (12:17pm)

Y:\Clients\SCOT Scott A Moskowitz and Wistaria Trading,
Inc\SCOT0014-4\Drafts\Amendment_SCOT0014-4_6-30-2011.wpd

1-31. (Canceled)

32. (Previously Presented) A computer-based method for modifying software, comprising:

receiving, in a computer having a processor and memory, software, wherein said software provides a specified functionality;

embedding a watermark into said software, using said computer, said watermark encoding at least one first license code, thereby resulting in a first license code encoded watermarked software.

33. (Previously Presented) The process of claim 32, wherein said embedding increases the complexity of code analysis and/or tampering with said first license code encoded watermarked software.

34. (Previously Presented) The process of claim 32, wherein said first license code encoded watermarked software is configured to query a user for personalization information during its installation.

35. (Previously Presented) The process of claim 32, wherein said watermark is accessible with a key.

36. (Previously Presented) The process of claim 35 wherein said key enables said first license code encoded watermarked software to provide said specified functionality.

37. (Currently Amended) The process according to claim ~~[[34]]~~ 35, wherein said first license code encoded watermarked software is configured to determine said key from said personalization information.

38. (Original) The process according to claim 32, wherein the step of embedding

the software with a watermark is performed during execution of the software.

39. (Previously Presented) The process according to claim 32, wherein said embedding modifies the structure of said software.

40. (Previously Presented) An article of manufacture comprising a machine readable medium, having thereon stored instructions adapted to be executed by a processor of a computer system, said computer system including a memory, which instructions when executed by said computer system result in a process comprising:

said computer system storing a software in said memory;

said computer system receiving licensing information as an input and using said licensing information in an algorithm to identify a watermark in said software.

41. (Previously Presented) The article of manufacture of claim 40, wherein said watermark encodes therein information defining an executable code providing a functionality of said software.

42. (Original) The article of manufacture of claim 40, wherein the watermark affects functionality of the watermarked software.

43. (Previously Presented) The article of manufacture of claim 41, wherein said instructions comprise decode instructions for said computer system to use said information to generate a decode key for decoding said software.

44. (Previously Presented) The article of manufacture of claim 43, wherein said identifying information comprises a license key, and said decode instructions instruct said computer to determine said license key from said information and to generate said decode key using said license key.

45. (Previously Presented) The article of manufacture of claim 40:
wherein said watermark encodes a license key;
said instructions include a prompt to enter licensing information;
wherein said software provides a certain functionality after receipt of licensing information in response to said prompt only if said licensing information comprises a license key encoded in said watermark.

46 – 51. (Canceled)

52. (Previously Presented) A computer-based system for modifying software, comprising:
a computer having a processor and memory;
wherein said computer is programmed to receive software that provides a specified functionality when installed on a computer system;
wherein said computer is programmed to embed a watermark into said software;
wherein said watermark encodes at least one first license code, thereby resulting in a first license code encoded watermarked software.

53. (Previously Presented) The system of claim 52 wherein said computer is programmed to use said at least one first license code as an input in an algorithm for embedding said watermark with said at least one first license code.

54. (Previously Presented) The system of claim 52 wherein said first license code encoded watermarked software is designed to prompt for entry of licensing information and only provides a certain functionality if licensing information entered in response to said prompt comprises at least one of said at least one first license code encoded in said watermark.

55. (Previously Presented) The system of claim 53, wherein said at least one first license code is fixed prior to distribution of the software.

56. (Previously Presented) The system of claim 52 wherein said at least one first license code comprises computer code that provides different functionality to said first license code encoded watermarked software compared to said software.

57. (Previously Presented) The system of claim 52, wherein said first license code encoded watermarked software is resistant to code analysis and/or tampering.

58. (Previously Presented) A method for licensed software use, the method comprising:
loading a software product on a computer, said computer comprising a processor, memory, an input, and an output, so that said computer is programmed to execute said software product;
said software product outputting a prompt for input of license information; and
said software product using license information entered via said input in response to said prompt in a routine designed to decode a first license code encoded in said software.

59. (Previously Presented) A method for encoding software code using a computer having a processor and memory, comprising:
storing a software code in said memory;
wherein said software code comprises a first code resource and provides a specified underlying functionality when installed on a computer system; and
encoding, by said computer using at least a first license key and an encoding algorithm, said software code, to form a first license key encoded software code.

60. (Previously Presented) The method of claim 59 wherein, when installed on a computer system, said first license key encoded software code will provide said specified underlying functionality only after receipt of said first license key.

61. (Previously Presented) A method for encoding software code using a

computer having a processor and memory, comprising:

storing a software code in said memory;

wherein said software code comprises a first code resource and provides a specified underlying functionality when installed on a computer system; and

modifying, by said computer, using a first license key and an encoding algorithm, said software code, to form a modified software code; and

wherein said modifying comprises encoding said first code resource to form an encoded first code resource;

wherein said modified software code comprises said encoded first code resource, and a decode resource for decoding said encoded first code resource;

wherein said decode resource is configured to decode said encoded first code resource upon receipt of said first license key.

62. (Previously Presented) A method for encoding software code using a computer having a processor and memory, comprising:

storing a software code in said memory;

wherein said software code defines software code interrelationships between code resources that result in a specified underlying functionality when installed on a computer system; and

encoding, by said computer using at least a first license key and an encoding algorithm, said software code, to form a first license key encoded software code in which at least one of said software code interrelationships are encoded.

63. (Previously Presented) A method for encoding software code using a computer having a processor and memory, comprising:

storing a software code in said memory;

wherein said software code provides a specified underlying functionality when installed on a computer system;

encoding, by said computer using at least a first license key and an encoding algorithm,

said software code, to form a first license key encoded software code;

encoding, by said computer using at least a second license key and an encoding algorithm, said software code, to form a second license key encoded software code;

wherein said first license key encoded software code is not identical to said second license key encoded software code if said first license key is not identical to said second license key.

64. (Previously Presented) The method of claim 63 wherein both said first license key encoded software code and said second license key encoded software code are capable of providing said specified underlying functionality when installed on a computer system.

ran

Date/time code: June 30, 2011 (11:32pm)

Y:\Clients\SCOT Scott A Moskowitz and Wistaria Trading,
Inc\SCOT0014-4\Drafts\Claims_SCOT0014-4_6-30-2011.wpd

Electronic Acknowledgement Receipt

EFS ID:	10437860
Application Number:	11895388
International Application Number:	
Confirmation Number:	2103
Title of Invention:	Data protection method and device
First Named Inventor/Applicant Name:	Scott A. Moskowitz
Customer Number:	31518
Filer:	Richard A. Neifeld
Filer Authorized By:	
Attorney Docket Number:	SCOT0014-4
Receipt Date:	01-JUL-2011
Filing Date:	24-AUG-2007
Time Stamp:	12:24:10
Application Type:	Utility under 35 USC 111(a)

Payment information:

Submitted with Payment	no
------------------------	----

File Listing:

Document Number	Document Description	File Name	File Size(Bytes)/ Message Digest	Multi Part /.zip	Pages (if appl.)
1	Applicant Arguments/Remarks Made in an Amendment	Amendment_SCOT0014-4_6-30-2011.pdf	472306 <small>3f3204c4d48521eb0959a2cd5f9e6edaa67ac01a</small>	no	9

Warnings:

Information:

2	Claims	Claims_SCOT0014-4_6-30-2011.pdf	143813 1bf150c8aa1c2984dc988324984316dc001129a	no	7
---	--------	---------------------------------	---	----	---

Warnings:

Information:

Total Files Size (in bytes):	616119
-------------------------------------	--------

This Acknowledgement Receipt evidences receipt on the noted date by the USPTO of the indicated documents, characterized by the applicant, and including page counts, where applicable. It serves as evidence of receipt similar to a Post Card, as described in MPEP 503.

New Applications Under 35 U.S.C. 111

If a new application is being filed and the application includes the necessary components for a filing date (see 37 CFR 1.53(b)-(d) and MPEP 506), a Filing Receipt (37 CFR 1.54) will be issued in due course and the date shown on this Acknowledgement Receipt will establish the filing date of the application.

National Stage of an International Application under 35 U.S.C. 371

If a timely submission to enter the national stage of an international application is compliant with the conditions of 35 U.S.C. 371 and other applicable requirements a Form PCT/DO/EO/903 indicating acceptance of the application as a national stage submission under 35 U.S.C. 371 will be issued in addition to the Filing Receipt, in due course.

New International Application Filed with the USPTO as a Receiving Office

If a new international application is being filed and the international application includes the necessary components for an international filing date (see PCT Article 11 and MPEP 1810), a Notification of the International Application Number and of the International Filing Date (Form PCT/RO/105) will be issued in due course, subject to prescriptions concerning national security, and the date shown on this Acknowledgement Receipt will establish the international filing date of the application.

Under the Paperwork Reduction Act of 1995, no persons are required to respond to a collection of information unless it displays a valid OMB control number.

PATENT APPLICATION FEE DETERMINATION RECORD Substitute for Form PTO-875					Application or Docket Number 11/895,388		Filing Date 08/24/2007		<input type="checkbox"/> To be Mailed					
APPLICATION AS FILED – PART I														
(Column 1)			(Column 2)			SMALL ENTITY <input checked="" type="checkbox"/>		OR		OTHER THAN SMALL ENTITY				
FOR		NUMBER FILED	NUMBER EXTRA		RATE (\$)	FEE (\$)	OR		RATE (\$)	FEE (\$)				
<input type="checkbox"/> BASIC FEE <small>(37 CFR 1.16(a), (b), or (c))</small>		N/A	N/A		N/A				N/A					
<input type="checkbox"/> SEARCH FEE <small>(37 CFR 1.16(k), (j), or (m))</small>		N/A	N/A		N/A		N/A							
<input type="checkbox"/> EXAMINATION FEE <small>(37 CFR 1.16(c), (p), or (q))</small>		N/A	N/A		N/A		N/A							
TOTAL CLAIMS <small>(37 CFR 1.16(i))</small>		minus 20 =	*		X \$ =		OR		X \$ =					
INDEPENDENT CLAIMS <small>(37 CFR 1.16(h))</small>		minus 3 =	*		X \$ =		OR		X \$ =					
<input type="checkbox"/> APPLICATION SIZE FEE <small>(37 CFR 1.16(s))</small>		If the specification and drawings exceed 100 sheets of paper, the application size fee due is \$250 (\$125 for small entity) for each additional 50 sheets or fraction thereof. See 35 U.S.C. 41(a)(1)(G) and 37 CFR 1.16(s).												
<input type="checkbox"/> MULTIPLE DEPENDENT CLAIM PRESENT <small>(37 CFR 1.16(j))</small>														
* If the difference in column 1 is less than zero, enter "0" in column 2.														
APPLICATION AS AMENDED – PART II										TOTAL	TOTAL			
(Column 1)			(Column 2)			(Column 3)			SMALL ENTITY		OR		OTHER THAN SMALL ENTITY	
AMENDMENT	07/01/2011	CLAIMS REMAINING AFTER AMENDMENT		HIGHEST NUMBER PREVIOUSLY PAID FOR	PRESENT EXTRA	RATE (\$)	ADDITIONAL FEE (\$)	OR		RATE (\$)	ADDITIONAL FEE (\$)			
	Total <small>(37 CFR 1.16(i))</small>	* 27	Minus	** 33	= 0	X \$26 =	0	OR		X \$ =				
	Independent <small>(37 CFR 1.16(h))</small>	* 8	Minus	***8	= 0	X \$110 =	0	OR		X \$ =				
	<input type="checkbox"/> Application Size Fee <small>(37 CFR 1.16(s))</small>													
	<input type="checkbox"/> FIRST PRESENTATION OF MULTIPLE DEPENDENT CLAIM <small>(37 CFR 1.16(j))</small>													
						TOTAL ADD'L FEE	0	OR		TOTAL ADD'L FEE				
AMENDMENT		CLAIMS REMAINING AFTER AMENDMENT		HIGHEST NUMBER PREVIOUSLY PAID FOR	PRESENT EXTRA	RATE (\$)	ADDITIONAL FEE (\$)	OR		RATE (\$)	ADDITIONAL FEE (\$)			
	Total <small>(37 CFR 1.16(i))</small>	*	Minus	**	=	X \$ =		OR		X \$ =				
	Independent <small>(37 CFR 1.16(h))</small>	*	Minus	***	=	X \$ =		OR		X \$ =				
	<input type="checkbox"/> Application Size Fee <small>(37 CFR 1.16(s))</small>													
	<input type="checkbox"/> FIRST PRESENTATION OF MULTIPLE DEPENDENT CLAIM <small>(37 CFR 1.16(j))</small>													
						TOTAL ADD'L FEE		OR		TOTAL ADD'L FEE				
* If the entry in column 1 is less than the entry in column 2, write "0" in column 3.														
** If the "Highest Number Previously Paid For" IN THIS SPACE is less than 20, enter "20".														
*** If the "Highest Number Previously Paid For" IN THIS SPACE is less than 3, enter "3".														
The "Highest Number Previously Paid For" (Total or Independent) is the highest number found in the appropriate box in column 1.														

Legal Instrument Examiner:
/NINA RATANAVONG/

This collection of information is required by 37 CFR 1.16. The information is required to obtain or retain a benefit by the public which is to file (and by the USPTO to process) an application. Confidentiality is governed by 35 U.S.C. 122 and 37 CFR 1.14. This collection is estimated to take 12 minutes to complete, including gathering, preparing, and submitting the completed application form to the USPTO. Time will vary depending upon the individual case. Any comments on the amount of time you require to complete this form and/or suggestions for reducing this burden, should be sent to the Chief Information Officer, U.S. Patent and Trademark Office, U.S. Department of Commerce, P.O. Box 1450, Alexandria, VA 22313-1450. DO NOT SEND FEES OR COMPLETED FORMS TO THIS ADDRESS. **SEND TO: Commissioner for Patents, P.O. Box 1450, Alexandria, VA 22313-1450.**

If you need assistance in completing the form, call 1-800-PTO-9199 and select option 2.



UNITED STATES PATENT AND TRADEMARK OFFICE

UNITED STATES DEPARTMENT OF COMMERCE
United States Patent and Trademark Office
Address: COMMISSIONER FOR PATENTS
P.O. Box 1450
Alexandria, Virginia 22313-1450
www.uspto.gov

APPLICATION NO.	FILING DATE	FIRST NAMED INVENTOR	ATTORNEY DOCKET NO.	CONFIRMATION NO.
11/895,388	08/24/2007	Scott A. Moskowitz	SCOT0014-4	2103
31518	7590	09/20/2011	EXAMINER	
NEIFELD IP LAW, PC 4813-B EISENHOWER AVENUE ALEXANDRIA, VA 22304			OKEKE, IZUNNA	
			ART UNIT	PAPER NUMBER
			2432	
			NOTIFICATION DATE	DELIVERY MODE
			09/20/2011	ELECTRONIC

Please find below and/or attached an Office communication concerning this application or proceeding.

The time period for reply, if any, is set in the attached communication.

Notice of the Office communication was sent electronically on above-indicated "Notification Date" to the following e-mail address(es):

general@neifeld.com
rneifeld@neifeld.com
rhahl@neifeld.com

DETAILED ACTION

Response to Arguments

1. Applicant's arguments filed 07/01/2011 have been fully considered but they are not persuasive.

With respect to claim 32, applicant argues that the combination of Holmes and Houser fails to anticipate the independent claim. In making this argument, applicant dwells on language in the specification which is not recited in the claims. The claims (which are what is being examined) recite subject matter which is very broad when compared to the arguments presented. For instance, on page 6 of the remarks, applicant argues that “the specification indicates that a particular license code is what is required to be input into a system running a particular software object.....”. In contrast, claim 32 recites in part, “said watermark encoding at least one first license code, thereby resulting in a first license code encoded watermarked software”. Contrary to applicant’s argument, the claim does not recite/require a particular license code (type, version, etc) or a particular software object (type, version, etc). Instead, the claims only recite the general terms ‘software’ and ‘license code’. Furthermore, on Page 8 of the remark, applicant asserts that claim 32’s preamble recites/teaches modifying the underlying functionality of the software. Examiner notes that claim 32’s preamble recites “a computer-based method for modifying software”. This language is quite different in scope from applicant’s assertion in that “modifying software” is much broader than “modifying the underlying functionality of the software”. With this in mind, let’s consider claim 32 with respect to its language and scope and then consider the rejection (combination of Holmes and Houser) presented in the last office action. Claim 32 recites a method for modifying software wherein the software has a specified

functionality. The software is modified by embedding a watermark in the software wherein the watermark contains (encodes) a license code thereby making the software a license code watermarked software. Holmes teaches a software file which has a specified functionality and has embedded within it a block of data code. The block of embedded code serves as a license code to provide identifying data for the software file. Holmes doesn't teach embedding the block of identification code as a watermark but Houser which teaches embedding codes in software as a watermark was used to remedy the teaching of Holmes with the rationale that embedded watermarks are difficult to forge and remove. (See the rejection to claim 32 in the last office action). Therefore, with respect to the language and scope of independent claim 32, the combination of Holmes and Houser fully anticipates the claim. The rest of the argument presented with respect to the teachings (prior arts) of Holmes and Houser are quite irrelevant because the claims do not recite the argued points. For instance, "the type of license code", "the location of the data block", etc. In view of the explanation above, examiner maintains the rejection because the claim as presented is fully anticipated by the combination of Holmes and Houser as outlined in the 35 U.S.C. 103 rejection below.

2. Applicant's argument, filed 07/01/2011, with respect to 35 U.S.C. 112 first paragraph rejection has been fully considered and is persuasive. The 112 rejection of claims 62-64 has been withdrawn. However, with respect to the specification in Para 51 and 52 of the publication which discloses "code resources" as sub-objects which can be packaged into what are referred to as code resources, examiner notes that the claimed inter-relationships is the relationship between these sub-objects (entry-points when called during compilation, etc) when they are being

packaged/compiled into code and also asserts that any software or compiled code as known in the art comprises these sub-objects and inter-relationships.

Claim Rejections - 35 USC § 103

3. The following is a quotation of 35 U.S.C. 103(a) which forms the basis for all obviousness rejections set forth in this Office action:

(a) A patent may not be obtained though the invention is not identically disclosed or described as set forth in section 102 of this title, if the differences between the subject matter sought to be patented and the prior art are such that the subject matter as a whole would have been obvious at the time the invention was made to a person having ordinary skill in the art to which said subject matter pertains. Patentability shall not be negated by the manner in which the invention was made.

4. Claims 32-45 and 52-64 are rejected under 35 U.S.C. 103(a) as being unpatentable over Holmes et al. (US-5287407), and further in view of Houser et al. (US-5606609).

a. Referring to claims 32, 40, 41, 45, 52, 55, 58 and 59:

Regarding claims 32, 40, 41, 45, 52, 55, 58 and 59, Holmes teaches a computer-based method for modifying software, comprising: receiving, in a computer having a processor and memory, software, wherein said software provides a specified functionality (See the response to arguments and Col 1, Line 60 thru Col 2, Line 4 and Line 10-20 and Col 3, Line 38-45 and Col 3, Line 67 thru Col 4, Line 4... method for modifying software which provides a specified functionality when executed by embedding a code in the software such as a unique identifying data (which could serve as a license for the software) associated with a user or the system or the software)

Holmes teaches embedding an identification data into the software. Holmes does not teach embedding the data as a watermark. However, embedding information as an electronic watermark is well known in the art. For instance, Houser teaches embedding information as a digital watermark into a media (See Houser, Col 16, Line 59-65.... electronically watermarked

graphic/video file). Therefore, one of ordinary skill in the art would have been motivated to modify Holmes' teaching by embedding the identification data as a watermark wherein the watermark cannot be forged and is also difficult to remove for the purpose of protecting the watermarked software and preventing unauthorized users from tampering with the identification data.

a. Referring to claims 33 and 57:

Regarding claims 33 and 57, the combination of Holmes and Houser teaches the process of claim 32, wherein said embedding increases the complexity of code analysis and/or tampering with said first license code encoded watermarked software (See the reason for watermarking identification data in the rejection in claim 32 and Holmes, Col 2, Line 2-4... said embedding of identification code enhances software security against tampering)

a. Referring to claims 34 and 54:

Regarding claims 34 and 54, the combination of Holmes and Houser teaches the process of claim 32, wherein said first license code encoded watermarked software is configured to query a user for personalization information during its installation (See Holmes, Col 3, Line 67 thru Col 4, Line 12... verifying the embedded identification data during software installation/copying).

a. Referring to claims 35 and 53:

Regarding claims 35 and 53, the combination of Holmes and Houser teaches the process of claim 32, wherein said watermark is accessible with a key (See Houser, Col 9, Line 37-60...watermark is protected with a key which is used to decode the watermark).

a. Referring to claims 36 and 60:

Regarding claims 36 and 60, the combination of Holmes and Houser teaches the process of claim 35 wherein said key enables said first license code encoded watermarked software to provide said specified functionality (See Holmes, Col 4, Line 16-17... executing/copying the software code based on successful verification).

a. Referring to claims 37 and 44:

Regarding claims 37 and 44, the combination of Holmes and Houser teaches the process according to claim 34, wherein said first license code encoded watermarked software is configured to determine said key from said personalization information (See Houser, Col 9, Line 37-60... determining key from password/identification data).

a. Referring to claim 38:

Regarding claim 38, the combination of Holmes and Houser teaches the process according to claim 32, wherein the step of embedding the software with a watermark is performed during execution of the software (See Holmes, Col 3, Line 38-46) .

a. Referring to claim 39:

Regarding claim 39, the combination of Holmes and Houser teaches the process according to claim 32, wherein said embedding modifies the structure of said software (See Holmes, Fig 1 and Col 3, Line 38-46... embedding the code modifies the software code from its original structure).

a. Referring to claims 42 and 56:

Regarding claims 42 and 56, the combination of Holmes and Houser teaches the article of manufacture of claim 40, wherein the watermark affects functionality of the watermarked

software (See Holmes, Col 3, Line 67 thru Col 4, Line 4... the protection affects the functionality of the software by first running an verification process before execution).

a. Referring to claim 43:

Regarding claim 43, the combination of Holmes and Houser teaches the article of manufacture of claim 41, wherein said instructions comprise decode instructions for said computer system to use said information to generate a decode key for decoding said software (See Holmes, Col 3, Line 67 thru Col 4, Line 4... identification data used to verify/decode the software for installation/copying).

a. Referring to claim 61:

Regarding claim 61, the combination of Holmes and Houser teaches a method for encoding software code using a computer having a processor and memory, comprising: storing a software code in said memory; wherein said software code comprises a first code resource and provides a specified underlying functionality when installed on a computer system (See the rejection in claim 32); and modifying, by said computer, using a first license key and an encoding algorithm, said software code, to form a modified software code; and wherein said modifying comprises encoding said first code resource to form an encoded first code resource (See the rejection in claim 32... modifying the software code by embedding a code resource in the software code); wherein said modified software code comprises said encoded first code resource, and a decode resource for decoding said encoded first code resource; wherein said decode resource is configured to decode said encoded first code resource upon receipt of said first license key (See the rejection in claim 43)

a. Referring to claims 62-64:

Regarding claims 62-64, the combination of Holmes and Houser teaches a method for encoding software code using a computer having a processor and memory, comprising: storing a software code in said memory; wherein said software code defines software code interrelationships between code resources that result in a specified underlying functionality when installed on a computer system; and encoding, by said computer using at least a first license key and an encoding algorithm, said software code, to form a first license key encoded software code in which at least one of said software code interrelationships are encoded (See the rejection in claims 32 and 61 and the response to the 112 1st argument).

Conclusion

5. **THIS ACTION IS MADE FINAL.** Applicant is reminded of the extension of time policy as set forth in 37 CFR 1.136(a).

A shortened statutory period for reply to this final action is set to expire THREE MONTHS from the mailing date of this action. In the event a first reply is filed within TWO MONTHS of the mailing date of this final action and the advisory action is not mailed until after the end of the THREE-MONTH shortened statutory period, then the shortened statutory period will expire on the date the advisory action is mailed, and any extension fee pursuant to 37 CFR 1.136(a) will be calculated from the mailing date of the advisory action. In no event, however, will the statutory period for reply expire later than SIX MONTHS from the mailing date of this final action.

Any inquiry concerning this communication or earlier communications from the examiner should be directed to IZUNNA OKEKE whose telephone number is (571)270-3854. The examiner can normally be reached on Monday - Thursday.

If attempts to reach the examiner by telephone are unsuccessful, the examiner's supervisor, Gilberto Barron can be reached on (571) 270-3799. The fax phone number for the organization where this application or proceeding is assigned is 571-273-8300.

Information regarding the status of an application may be obtained from the Patent Application Information Retrieval (PAIR) system. Status information for published applications may be obtained from either Private PAIR or Public PAIR. Status information for unpublished applications is available through Private PAIR only. For more information about the PAIR system, see <http://pair-direct.uspto.gov>. Should you have questions on access to the Private PAIR system, contact the Electronic Business Center (EBC) at 866-217-9197 (toll-free). If you would like assistance from a USPTO Customer Service Representative or access to the automated information system, call 800-786-9199 (IN USA OR CANADA) or 571-272-1000.

/IZUNNA OKEKE/
Examiner, Art Unit 2432

/Minh Dinh/
Primary Examiner, Art Unit 2432

Notice of References Cited	Application/Control No. 11/895,388	Applicant(s)/Patent Under Reexamination MOSKOWITZ, SCOTT A.	
	Examiner IZUNNA OKEKE	Art Unit 2432	Page 1 of 1

U.S. PATENT DOCUMENTS

*	Document Number Country Code-Number-Kind Code	Date MM-YYYY	Name	Classification
*	A US-5,287,407	02-1994	Holmes, Keith	705/58
*	B US-5,606,609	02-1997	Houser et al.	713/179
	C US-			
	D US-			
	E US-			
	F US-			
	G US-			
	H US-			
	I US-			
	J US-			
	K US-			
	L US-			
	M US-			

FOREIGN PATENT DOCUMENTS

*	Document Number Country Code-Number-Kind Code	Date MM-YYYY	Country	Name	Classification
	N				
	O				
	P				
	Q				
	R				
	S				
	T				

NON-PATENT DOCUMENTS

*	Include as applicable: Author, Title Date, Publisher, Edition or Volume, Pertinent Pages)
U	
V	
W	
X	

*A copy of this reference is not being furnished with this Office action. (See MPEP § 707.05(a).)
Dates in MM-YYYY format are publication dates. Classifications may be US or foreign.

Search Notes 	Application/Control No. 11895388	Applicant(s)/Patent Under Reexamination MOSKOWITZ, SCOTT A.
	Examiner IZUNNA OKEKE	Art Unit 2432

SEARCHED			
Class	Subclass	Date	Examiner

SEARCH NOTES		
Search Notes	Date	Examiner
Updated Text Search (See History)	3/16/2011	IO
Updated Keyword + Classification Search (See History)	3/16/2011	IO
Search (713/165, 713/176, 713/161, 380/201, 380/228, 380/229) (See History)	3/16/2011	IO
NPL Search	3/16/2011	IO

INTERFERENCE SEARCH			
Class	Subclass	Date	Examiner

--	--

EAST Search History

EAST Search History (Prior Art)

Ref #	Hits	Search Query	DBs	Default Operator	Plurals	Time Stamp
S1	3060	(watermark near3 (software or program or application))	US-PGPUB; USPAT; USOCR; FPRS; EPO; JPO; DERWENT; IBM_TDB	AND	ON	2011/03/16 13:21
S3	193	(watermark near3 (software or program or application)) and (@ad<"19960117" or @rlad<"19960117")	US-PGPUB; USPAT; USOCR; FPRS; EPO; JPO; DERWENT; IBM_TDB	AND	ON	2011/03/16 13:23
S7	21	(watermark near3 (software or program or application)) and (@ad<"19960117")	US-PGPUB; USPAT; USOCR; FPRS; EPO; JPO; DERWENT; IBM_TDB	AND	ON	2011/03/16 22:01
S9	94	(watermark same (software or program or application)) and (@ad<"19960117")	US-PGPUB; USPAT; USOCR; FPRS; EPO; JPO; DERWENT; IBM_TDB	AND	ON	2011/03/16 22:26

S10	51	(watermark with (software or program or application)) and (@ad<"19960117")	US-PGPUB; USPAT; USOCR; FPRS; EPO; JPO; DERWENT; IBM_TDB	AND	ON	2011/03/16 22:26
S12	3	(watermark same ((software or program or application) with protect\$3)) and (@ad<"19960117")	US-PGPUB; USPAT; USOCR; FPRS; EPO; JPO; DERWENT; IBM_TDB	AND	ON	2011/03/16 22:52
S14	3	((watermark or stega\$5) same ((software or program or application) with protect\$3)) and (@ad<"19960117")	US-PGPUB; USPAT; USOCR; FPRS; EPO; JPO; DERWENT; IBM_TDB	AND	ON	2011/03/16 23:08
S15	3	((watermark or steganograph\$5) same ((software or program or application) with protect\$3)) and (@ad<"19960117")	US-PGPUB; USPAT; USOCR; FPRS; EPO; JPO; DERWENT; IBM_TDB	AND	ON	2011/03/16 23:08
S16	8	((watermark or steganograph\$5) same ((software or program or application) same protect\$3)) and (@ad<"19960117")	US-PGPUB; USPAT; USOCR; FPRS; EPO; JPO; DERWENT; IBM_TDB	AND	ON	2011/03/16 23:09

S18	15	((watermark or steganograph\$5) same ((software or program or application) and protect\$3)) and (@ad<"19960117")	US-PGPUB; USPAT; USOCR; FPRS; EPO; JPO; DERWENT; IBM_TDB	AND	ON	2011/03/16 23:22
S19	1361	((embed\$4) same ((software or program or application) and protect\$3)) and (@ad<"19960117")	US-PGPUB; USPAT; USOCR; FPRS; EPO; JPO; DERWENT; IBM_TDB	AND	ON	2011/03/16 23:23
S20	101	((embed\$4) same ((software or program or application) near3 protect\$3)) and (@ad<"19960117")	US-PGPUB; USPAT; USOCR; FPRS; EPO; JPO; DERWENT; IBM_TDB	AND	ON	2011/03/16 23:23
S21	3	((watermark or (crypto\$5 near3 code)) same ((software or program or application) near3 protect\$3)) and (@ad<"19960117")	US-PGPUB; USPAT; USOCR; FPRS; EPO; JPO; DERWENT; IBM_TDB	AND	ON	2011/03/17 00:02
S22	6	((watermark or (cryptograph\$5 near3 code)) same ((software or program or application) near3 protect\$3)) and (@ad<"19960117")	US-PGPUB; USPAT; USOCR; FPRS; EPO; JPO; DERWENT; IBM_TDB	AND	ON	2011/03/17 00:03

S23	7	((watermark or (cryptograph\$5 near3 code)) same ((software or program or application) near5 protect\$3)) and (@ad<"19960117")	US-PGPUB; USPAT; USOCR; FPRS; EPO; JPO; DERWENT; IBM_TDB	AND	ON	2011/03/17 00:03
S24	49	((watermark or (cryptograph\$5 near3 code)) and ((software or program or application) near5 protect\$3)) and (@ad<"19960117")	US-PGPUB; USPAT; USOCR; FPRS; EPO; JPO; DERWENT; IBM_TDB	AND	ON	2011/03/17 00:03
S25	39	((watermark or (cryptograph\$5 near3 code)) and ((software or program or application) near3 protect\$3)) and (@ad<"19960117")	US-PGPUB; USPAT; USOCR; FPRS; EPO; JPO; DERWENT; IBM_TDB	AND	ON	2011/03/17 00:04
S26	22	((watermark or (cryptograph\$5 near3 code)) and ((software) near3 protect\$3)) and (@ad<"19960117")	US-PGPUB; USPAT; USOCR; FPRS; EPO; JPO; DERWENT; IBM_TDB	AND	ON	2011/03/17 00:04
S27	113	((watermark or (cryptograph\$5)) and ((software) near3 protect\$3)) and (@ad<"19960117")	US-PGPUB; USPAT; USOCR; FPRS; EPO; JPO; DERWENT; IBM_TDB	AND	ON	2011/03/17 00:06

S28	8284	713/165,176,161,167;380/201,228,229.ccls.	US-PGPUB; USPAT; USOCR; FPRS; EPO; JPO; DERWENT; IBM_TDB	AND	ON	2011/03/17 10:03
S29	1361	((embed\$4) same ((software or program or application) and protect\$3)) and (@ad<"19960117")	US-PGPUB; USPAT; USOCR; FPRS; EPO; JPO; DERWENT; IBM_TDB	AND	ON	2011/03/17 10:04
S30	11	S29 and S28	US-PGPUB; USPAT; USOCR; FPRS; EPO; JPO; DERWENT; IBM_TDB	AND	ON	2011/03/17 10:04
S31	3065	(watermark near3 (software or program or application))	US-PGPUB; USPAT; USOCR; FPRS; EPO; JPO; DERWENT; IBM_TDB	AND	ON	2011/03/17 10:06
S32	638	S31 and S28	US-PGPUB; USPAT; USOCR; FPRS; EPO; JPO; DERWENT; IBM_TDB	AND	ON	2011/03/17 10:06
S33	101	((embed\$4) same ((software or program or application) near3 protect\$3)) and (@ad<"19960117")	US-PGPUB; USPAT; USOCR; FPRS; EPO; JPO; DERWENT; IBM_TDB	AND	ON	2011/03/17 10:06

S34	1	S28 and S33	US-PGPUB; USPAT; USOCR; FPRS; EPO; JPO; DERWENT; IBM_TDB	AND	ON	2011/03/17 10:06
S35	113	((watermark or (cryptograph\$5)) and ((software) near3 protect\$3)) and (@ad<"19960117")	US-PGPUB; USPAT; USOCR; FPRS; EPO; JPO; DERWENT; IBM_TDB	AND	ON	2011/03/17 10:06
S36	20	S28 and S35	US-PGPUB; USPAT; USOCR; FPRS; EPO; JPO; DERWENT; IBM_TDB	AND	ON	2011/03/17 10:06
S38	94	(watermark same ((software or program or application))) and (@ad<"19960117")	US-PGPUB; USPAT; USOCR; FPRS; EPO; JPO; DERWENT; IBM_TDB	AND	ON	2011/03/17 11:56
S39	21	(watermark near3 ((software or program or application))) and (@ad<"19960117")	US-PGPUB; USPAT; USOCR; FPRS; EPO; JPO; DERWENT; IBM_TDB	AND	ON	2011/03/17 11:57
S40	5	(watermark\$3 adj ((software or program or application))) and (@ad<"19960117")	US-PGPUB; USPAT; USOCR; FPRS; EPO; JPO; DERWENT; IBM_TDB	AND	ON	2011/03/17 11:57

S41	11	(watermark same ((software))) and (@ad<"19960117")	US-PGPUB; USPAT; USOCR; FPRS; EPO; JPO; DERWENT; IBM_TDB	AND	ON	2011/03/17 11:57
S42	12	(watermark\$3 same ((software))) and (@ad<"19960117")	US-PGPUB; USPAT; USOCR; FPRS; EPO; JPO; DERWENT; IBM_TDB	AND	ON	2011/03/17 11:59
S43	51	(watermark with (software or program or application)) and (@ad<"19960117")	US-PGPUB; USPAT; USOCR; FPRS; EPO; JPO; DERWENT; IBM_TDB	AND	ON	2011/03/17 12:03
S44	95	((watermark or steganograph\$5) same ((software or program or application))) and (@ad<"19960117")	US-PGPUB; USPAT; USOCR; FPRS; EPO; JPO; DERWENT; IBM_TDB	AND	ON	2011/03/17 12:07
S45	36	((watermark or steganograph\$5) near5 ((software or program or application))) and (@ad<"19960117")	US-PGPUB; USPAT; USOCR; FPRS; EPO; JPO; DERWENT; IBM_TDB	AND	ON	2011/03/17 12:07
S46	51	((watermark or steganograph\$5) with ((software or program or application))) and (@ad<"19960117")	US-PGPUB; USPAT; USOCR; FPRS; EPO; JPO; DERWENT; IBM_TDB	AND	ON	2011/03/17 12:08

S47	5	((watermark or steganograph\$5) with ((software))) and (@ad<"19960117")	US-PGPUB; USPAT; USOCR; FPRS; EPO; JPO; DERWENT; IBM_TDB	AND	ON	2011/03/17 12:09
S48	396	((watermark or steganograph\$5) and ((software or program or application))) and (@ad<"19960117")	US-PGPUB; USPAT; USOCR; FPRS; EPO; JPO; DERWENT; IBM_TDB	AND	ON	2011/03/17 12:11
S49	82	((watermark or steganograph\$5) and ((software))) and (@ad<"19960117")	US-PGPUB; USPAT; USOCR; FPRS; EPO; JPO; DERWENT; IBM_TDB	AND	ON	2011/03/17 12:11
S50	81	((watermark) and ((software))) and (@ad<"19960117")	US-PGPUB; USPAT; USOCR; FPRS; EPO; JPO; DERWENT; IBM_TDB	AND	ON	2011/03/17 12:12
S51	36	(watermark near5 ((software or program or application))) and (@ad<"19960117")	US-PGPUB; USPAT; USOCR; FPRS; EPO; JPO; DERWENT; IBM_TDB	AND	ON	2011/03/17 12:20
S52	44	(watermark near5 ((code or software or program or application))) and (@ad<"19960117")	US-PGPUB; USPAT; USOCR; FPRS; EPO; JPO; DERWENT; IBM_TDB	AND	ON	2011/03/17 12:20

S53	48	(watermark\$3 near5 (code or software or program or application)) and (@ad<"19960117")	US-PGPUB; USPAT; USOCR; FPRS; EPO; JPO; DERWENT; IBM_TDB	AND	ON	2011/03/17 12:31
S54	83	(watermark\$3 with (code or software or program or application)) and (@ad<"19960117")	US-PGPUB; USPAT; USOCR; FPRS; EPO; JPO; DERWENT; IBM_TDB	AND	ON	2011/03/17 12:32
S55	11	(watermark\$3 near3 (protect\$3)) and (@ad<"19960117")	US-PGPUB; USPAT; USOCR; FPRS; EPO; JPO; DERWENT; IBM_TDB	AND	ON	2011/03/17 12:36
S56	10	((watermark near5 signature) and ((software or program or application))) and (@ad<"19960117")	US-PGPUB; USPAT; USOCR; FPRS; EPO; JPO; DERWENT; IBM_TDB	AND	ON	2011/03/17 12:44
S57	1	(digital same (watermark near5 signature) and ((software or program or application))) and (@ad<"19960117")	US-PGPUB; USPAT; USOCR; FPRS; EPO; JPO; DERWENT; IBM_TDB	AND	ON	2011/03/17 12:44
S58	1	(digital same (watermark near5 signature)) and (@ad<"19960117")	US-PGPUB; USPAT; USOCR; FPRS; EPO; JPO; DERWENT; IBM_TDB	AND	ON	2011/03/17 12:44

S59	1	(watermark same (digital adj signature)) and (@ad<"19960117")	US-PGPUB; USPAT; USOCR; FPRS; EPO; JPO; DERWENT; IBM_TDB	AND	ON	2011/03/17 12:49
S60	12	((watermark or steganograph\$5) same ((software)) and (@ad<"19960117")	US-PGPUB; USPAT; USOCR; FPRS; EPO; JPO; DERWENT; IBM_TDB	AND	ON	2011/03/17 12:56
S64	6	((embed\$4 near3 watermark)) and (@ad<"19960117")	US-PGPUB; USPAT; USOCR; FPRS; EPO; JPO; DERWENT; IBM_TDB	AND	ON	2011/03/24 15:29
S65	8	((embed\$4 near5 watermark)) and (@ad<"19960117")	US-PGPUB; USPAT; USOCR; FPRS; EPO; JPO; DERWENT; IBM_TDB	AND	ON	2011/03/24 15:30
S66	18	((embed\$4 or insert\$3) near5 watermark)) and (@ad<"19960117")	US-PGPUB; USPAT; USOCR; FPRS; EPO; JPO; DERWENT; IBM_TDB	AND	ON	2011/03/24 15:33
S67	30	((electronic or digital) near5 watermark)) and (@ad<"19960117")	US-PGPUB; USPAT; USOCR; FPRS; EPO; JPO; DERWENT; IBM_TDB	AND	ON	2011/03/24 15:35

S68	28	(((electronic or digital) near3 watermark)) and (@ad<"19960117")	US-PGPUB; USPAT; USOCR; FPRS; EPO; JPO; DERWENT; IBM_TDB	AND	ON	2011/03/24 15:36
S69	32	(((embed\$4 or insert\$3) with watermark)) and (@ad<"19960117")	US-PGPUB; USPAT; USOCR; FPRS; EPO; JPO; DERWENT; IBM_TDB	AND	ON	2011/03/24 15:45

EAST Search History (Interference)

< This search history is empty >

9/ 8/ 2011 8:32:30 PM

C:\ Documents and Settings\ iokeke\ My Documents\ EAST\ Workspaces\ 11895388.wsp

Index of Claims 	Application/Control No. 11895388	Applicant(s)/Patent Under Reexamination MOSKOWITZ, SCOTT A.
	Examiner IZUNNA OKEKE	Art Unit 2432

✓	Rejected	-	Cancelled	N	Non-Elected	A	Appeal
=	Allowed	÷	Restricted	I	Interference	O	Objected

Claims renumbered in the same order as presented by applicant
 CPA
 T.D.
 R.1.47

CLAIM		DATE							
Final	Original	03/22/2010	11/11/2010	03/17/2011	09/08/2011				
	32	✓	✓	✓	✓				
	33	✓	✓	✓	✓				
	34	✓	✓	✓	✓				
	35	✓	✓	✓	✓				
	36	✓	✓	✓	✓				
	37	✓	✓	✓	✓				
	38	✓	✓	✓	✓				
	39	✓	✓	✓	✓				
	40	✓	✓	✓	✓				
	41	✓	✓	✓	✓				
	42	✓	✓	✓	✓				
	43	✓	✓	✓	✓				
	44	✓	✓	✓	✓				
	45	✓	✓	✓	✓				
	52	✓	✓	✓	✓				
	53	✓	✓	✓	✓				
	54	✓	✓	✓	✓				
	55	✓	✓	✓	✓				
	56	✓	✓	✓	✓				
	57	✓	✓	✓	✓				
	58	✓	✓	✓	✓				
	59	✓	✓	✓	✓				
	60		✓	✓	✓				
	61		✓	✓	✓				
	62		✓	✓	✓				
	63		✓	✓	✓				
	64		✓	✓	✓				



UNITED STATES PATENT AND TRADEMARK OFFICE

UNITED STATES DEPARTMENT OF COMMERCE
United States Patent and Trademark Office
Address: COMMISSIONER FOR PATENTS
P.O. Box 1450
Alexandria, Virginia 22313-1450
www.uspto.gov

Table with 5 columns: APPLICATION NO., FILING DATE, FIRST NAMED INVENTOR, ATTORNEY DOCKET NO., CONFIRMATION NO.
11/895,388 08/24/2007 Scott A. Moskowitz SCOT0014-4 2103

31518 7590 02/02/2012
NEIFELD IP LAW, PC
4813-B EISENHOWER AVENUE
ALEXANDRIA, VA 22304

Table with 1 column: EXAMINER

OKEKE, IZUNNA

Table with 2 columns: ART UNIT, PAPER NUMBER

2432

Table with 2 columns: NOTIFICATION DATE, DELIVERY MODE

02/02/2012

ELECTRONIC

Please find below and/or attached an Office communication concerning this application or proceeding.

The time period for reply, if any, is set in the attached communication.

Notice of the Office communication was sent electronically on above-indicated "Notification Date" to the following e-mail address(es):

general@neifeld.com
rneifeld@neifeld.com
rhahl@neifeld.com

Applicant-Initiated Interview Summary	Application No. 11/895,388	Applicant(s) MOSKOWITZ, SCOTT A.	
	Examiner IZUNNA OKEKE	Art Unit 2432	

All participants (applicant, applicant's representative, PTO personnel):

(1) IZUNNA OKEKE. (3) _____.

(2) RICK NEIFELD. (4) _____.

Date of Interview: 25 January 2012.

Type: Telephonic Video Conference
 Personal [copy given to: applicant applicant's representative]

Exhibit shown or demonstration conducted: Yes No.
If Yes, brief description: _____.

Issues Discussed 101 112 102 103 Others
(For each of the checked box(es) above, please describe below the issue and detailed description of the discussion)

Claim(s) discussed: 1.

Identification of prior art discussed: None.

Substance of Interview
(For each issue discussed, provide a detailed description and indicate if agreement was reached. Some topics may include: identification or clarification of a reference or a portion thereof, claim interpretation, proposed amendments, arguments of any applied references etc...)

Applicant's representative wanted to know if amendment of the independent claim will overcome the rejection of record. Examiner replied that an amendment has to be received/filed and a search updated before determining if the amendment overcomes the rejection of record. In the absence of an amendment or amended claim limitations, there is no way to determine if the rejection has been overcome. No agreement with respect to the claims was reached.

Applicant recordation instructions: The formal written reply to the last Office action must include the substance of the interview. (See MPEP section 713.04). If a reply to the last Office action has already been filed, applicant is given a non-extendable period of the longer of one month or thirty days from this interview date, or the mailing date of this interview summary form, whichever is later, to file a statement of the substance of the interview

Examiner recordation instructions: Examiners must summarize the substance of any interview of record. A complete and proper recordation of the substance of an interview should include the items listed in MPEP 713.04 for complete and proper recordation including the identification of the general thrust of each argument or issue discussed, a general indication of any other pertinent matters discussed regarding patentability and the general results or outcome of the interview, to include an indication as to whether or not agreement was reached on the issues raised.

Attachment

/IZUNNA OKEKE/ Examiner, Art Unit 2432	/Gilberto Barron Jr./ Supervisory Patent Examiner, Art Unit 2432
---	---

Summary of Record of Interview Requirements

Manual of Patent Examining Procedure (MPEP), Section 713.04, Substance of Interview Must be Made of Record

A complete written statement as to the substance of any face-to-face, video conference, or telephone interview with regard to an application must be made of record in the application whether or not an agreement with the examiner was reached at the interview.

Title 37 Code of Federal Regulations (CFR) § 1.133 Interviews

Paragraph (b)

In every instance where reconsideration is requested in view of an interview with an examiner, a complete written statement of the reasons presented at the interview as warranting favorable action must be filed by the applicant. An interview does not remove the necessity for reply to Office action as specified in §§ 1.111, 1.135. (35 U.S.C. 132)

37 CFR §1.2 Business to be transacted in writing.

All business with the Patent or Trademark Office should be transacted in writing. The personal attendance of applicants or their attorneys or agents at the Patent and Trademark Office is unnecessary. The action of the Patent and Trademark Office will be based exclusively on the written record in the Office. No attention will be paid to any alleged oral promise, stipulation, or understanding in relation to which there is disagreement or doubt.

The action of the Patent and Trademark Office cannot be based exclusively on the written record in the Office if that record is itself incomplete through the failure to record the substance of interviews.

It is the responsibility of the applicant or the attorney or agent to make the substance of an interview of record in the application file, unless the examiner indicates he or she will do so. It is the examiner's responsibility to see that such a record is made and to correct material inaccuracies which bear directly on the question of patentability.

Examiners must complete an Interview Summary Form for each interview held where a matter of substance has been discussed during the interview by checking the appropriate boxes and filling in the blanks. Discussions regarding only procedural matters, directed solely to restriction requirements for which interview recordation is otherwise provided for in Section 812.01 of the Manual of Patent Examining Procedure, or pointing out typographical errors or unreadable script in Office actions or the like, are excluded from the interview recordation procedures below. Where the substance of an interview is completely recorded in an Examiners Amendment, no separate Interview Summary Record is required.

The Interview Summary Form shall be given an appropriate Paper No., placed in the right hand portion of the file, and listed on the "Contents" section of the file wrapper. In a personal interview, a duplicate of the Form is given to the applicant (or attorney or agent) at the conclusion of the interview. In the case of a telephone or video-conference interview, the copy is mailed to the applicant's correspondence address either with or prior to the next official communication. If additional correspondence from the examiner is not likely before an allowance or if other circumstances dictate, the Form should be mailed promptly after the interview rather than with the next official communication.

The Form provides for recordation of the following information:

- Application Number (Series Code and Serial Number)
- Name of applicant
- Name of examiner
- Date of interview
- Type of interview (telephonic, video-conference, or personal)
- Name of participant(s) (applicant, attorney or agent, examiner, other PTO personnel, etc.)
- An indication whether or not an exhibit was shown or a demonstration conducted
- An identification of the specific prior art discussed
- An indication whether an agreement was reached and if so, a description of the general nature of the agreement (may be by attachment of a copy of amendments or claims agreed as being allowable). Note: Agreement as to allowability is tentative and does not restrict further action by the examiner to the contrary.
- The signature of the examiner who conducted the interview (if Form is not an attachment to a signed Office action)

It is desirable that the examiner orally remind the applicant of his or her obligation to record the substance of the interview of each case. It should be noted, however, that the Interview Summary Form will not normally be considered a complete and proper recordation of the interview unless it includes, or is supplemented by the applicant or the examiner to include, all of the applicable items required below concerning the substance of the interview.

A complete and proper recordation of the substance of any interview should include at least the following applicable items:

- 1) A brief description of the nature of any exhibit shown or any demonstration conducted,
- 2) an identification of the claims discussed,
- 3) an identification of the specific prior art discussed,
- 4) an identification of the principal proposed amendments of a substantive nature discussed, unless these are already described on the Interview Summary Form completed by the Examiner,
- 5) a brief identification of the general thrust of the principal arguments presented to the examiner,
(The identification of arguments need not be lengthy or elaborate. A verbatim or highly detailed description of the arguments is not required. The identification of the arguments is sufficient if the general nature or thrust of the principal arguments made to the examiner can be understood in the context of the application file. Of course, the applicant may desire to emphasize and fully describe those arguments which he or she feels were or might be persuasive to the examiner.)
- 6) a general indication of any other pertinent matters discussed, and
- 7) if appropriate, the general results or outcome of the interview unless already described in the Interview Summary Form completed by the examiner.

Examiners are expected to carefully review the applicant's record of the substance of an interview. If the record is not complete and accurate, the examiner will give the applicant an extendable one month time period to correct the record.

Examiner to Check for Accuracy

If the claims are allowable for other reasons of record, the examiner should send a letter setting forth the examiner's version of the statement attributed to him or her. If the record is complete and accurate, the examiner should place the indication, "Interview Record OK" on the paper recording the substance of the interview along with the date and the examiner's initials.

Neifeld Docket No: SCOT0014-4

Application/Patent No: 11/895,388

USPTO CONFIRMATION NO: 2103

File/Issue Date: 8/24/2007

Inventor/title: Moskowitz/ Data protection method and device

Examiner/ArtUnit: Izunna OKEKE/2432

ENTITY STATUS: SMALL (CONVERT UPON ALLOWANCE TO LARGE)

Priority: Application No. 09/046,627 (which issued July 22, 2003, as U.S. Patent No. 6,598,162)

**37 CFR 1.7© FILING RECEIPT AND TRANSMITTAL LETTER WITH
AUTHORIZATION TO CHARGE DEPOSIT ACCOUNT**

1. **THE COMMISSIONER IS HEREBY AUTHORIZED TO CHARGE ANY FEES WHICH MAY BE REQUIRED, OR CREDIT ANY OVERPAYMENT, TO DEPOSIT ACCOUNT NUMBER 50-2106.**

2. **FEES (PAID HEREWITH BY EFS CREDIT CARD SUBMISSION) \$ 945.00**

1253/2253 1.17(a)(3) Extension for response within third month 635.00

1401/2401 41.20(b)(1) Notice of appeal 310.00

3. **THE FOLLOWING DOCUMENTS ARE SUBMITTED HEREWITH:**

37 CFR 1.136(a) EXTENSION OF TIME - 3 MONTHS

37 CFR 41.31(a) NOTICE OF APPEAL

4. **FOR INTERNAL NEIFELD IP LAW, PC USE ONLY**

Bankacct/PClawMatter/ChkNo/date/amnt:

6/SCOT0001/1336/3-12-2012/\$945

Firm charge: \$400

INITIALS OF PERSON WHO **ENTERED** ACCOUNTING DATA: RAN

ATTORNEY SIGNATURE (AUTHORIZING DEPOSIT ACCOUNT)

3/12/2012 /RichardNeifeld#35,299/

RICHARD NEIFELD, REG. NO. 35,299

ATTORNEY OF RECORD

Printed: March 12, 2012 (6:38pm)

Y:\Clients\SCOT Scott A Moskowitz and Wistaria Trading,

Inc\SCOT0014-4\Drafts\EOT_NOA_SCOT0014-4_3-12-2012.wpd

Neifeld Docket No: SCOT0014-4

Application/Patent No: 11/895,388

USPTO CONFIRMATION NO: 2103

File/Issue Date: 8/24/2007

Inventor/title: Moskowitz/ Data protection method and device

Examiner/ArtUnit: Izunna OKEKE/2432

ENTITY STATUS: SMALL (CONVERT UPON ALLOWANCE TO LARGE)

Priority: Application No. 09/046,627 (which issued July 22, 2003, as U.S. Patent No. 6,598,162)

37 CFR 1.136(a) EXTENSION OF TIME - 3 MONTHS

This is an extension of time for 3 months to respond to the office action dated 9/20/2011, to extend the date for response to 3/20/2012.

A Notice of Appeal accompanies this extension.

Truly, /Richard Neifeld/

RICHARD NEIFELD, REG. NO. 35,299

ATTORNEY OF RECORD

ran

Date/TimeCode: March 12, 2012 (6:38pm)

Y:\Clients\SCOT Scott A Moskowitz and Wistaria Trading,

Inc\SCOT0014-4\Drafts\EOT_NOA_SCOT0014-4_3-12-2012.wpd

Neifeld Docket No: SCOT0014-4

Application/Patent No: 11/895,388

USPTO CONFIRMATION NO: 2103

File/Issue Date: 8/24/2007

Inventor/title: Moskowitz/ Data protection method and device

Examiner/ArtUnit: Izunna OKEKE/2432

ENTITY STATUS: SMALL (CONVERT UPON ALLOWANCE TO LARGE)

Priority: Application No. 09/046,627 (which issued July 22, 2003, as U.S. Patent No. 6,598,162)

37 CFR 41.31(a) NOTICE OF APPEAL

This is notice of appeal from the final office action dated 9/20/2012.

An extension of time to extend the date for response to 3/20/2012 accompanies this Notice.

Truly, /Richard Neifeld/

RICHARD NEIFELD, REG. NO. 35,299

ATTORNEY OF RECORD

ran

Date/TimeCode: March 12, 2012 (6:38pm)

Y:\Clients\SCOT Scott A Moskowitz and Wistaria Trading,

Inc\SCOT0014-4\Drafts\EOT_NOA_SCOT0014-4_3-12-2012.wpd

Electronic Patent Application Fee Transmittal

Application Number:	11895388			
Filing Date:	24-Aug-2007			
Title of Invention:	Data protection method and device			
First Named Inventor/Applicant Name:	Scott A. Moskowitz			
Filer:	Richard A. Neifeld			
Attorney Docket Number:	SCOT0014-4			
Filed as Small Entity				
Utility under 35 USC 111(a) Filing Fees				
Description	Fee Code	Quantity	Amount	Sub-Total in USD(\$)
Basic Filing:				
Pages:				
Claims:				
Miscellaneous-Filing:				
Petition:				
Patent-Appeals-and-Interference:				
Notice of appeal	2401	1	310	310
Post-Allowance-and-Post-Issuance:				
Extension-of-Time:				

Description	Fee Code	Quantity	Amount	Sub-Total in USD(\$)
Extension - 3 months with \$0 paid	2253	1	635	635
Miscellaneous:				
Total in USD (\$)				945

Electronic Acknowledgement Receipt

EFS ID:	12285130
Application Number:	11895388
International Application Number:	
Confirmation Number:	2103
Title of Invention:	Data protection method and device
First Named Inventor/Applicant Name:	Scott A. Moskowitz
Customer Number:	31518
Filer:	Richard A. Neifeld
Filer Authorized By:	
Attorney Docket Number:	SCOT0014-4
Receipt Date:	12-MAR-2012
Filing Date:	24-AUG-2007
Time Stamp:	18:42:05
Application Type:	Utility under 35 USC 111(a)

Payment information:

Submitted with Payment	yes
Payment Type	Credit Card
Payment was successfully received in RAM	\$ 945
RAM confirmation Number	6447
Deposit Account	502106
Authorized User	NEIFELD,RICHARD ALAN

The Director of the USPTO is hereby authorized to charge indicated fees and credit any overpayment as follows:

Charge any Additional Fees required under 37 C.F.R. Section 1.17 (Patent application and reexamination processing fees)

File Listing:

Document Number	Document Description	File Name	File Size(Bytes)/ Message Digest	Multi Part /.zip	Pages (if appl.)
1		EOT_NOA_SCOT0014-4_3-12-2012.pdf	52347 <small>9667761529ccaba772b3041f0047bc1d0893aef</small>	yes	3
Multipart Description/PDF files in .zip description					
	Document Description		Start		End
	Miscellaneous Incoming Letter		1		1
	Extension of Time		2		2
	Notice of Appeal Filed		3		3
Warnings:					
Information:					
2	Fee Worksheet (SB06)	fee-info.pdf	32008 <small>81cddb831c106399874c60b20e196f7a8e9ac59b</small>	no	2
Warnings:					
Information:					
Total Files Size (in bytes):			84355		
<p>This Acknowledgement Receipt evidences receipt on the noted date by the USPTO of the indicated documents, characterized by the applicant, and including page counts, where applicable. It serves as evidence of receipt similar to a Post Card, as described in MPEP 503.</p> <p><u>New Applications Under 35 U.S.C. 111</u> If a new application is being filed and the application includes the necessary components for a filing date (see 37 CFR 1.53(b)-(d) and MPEP 506), a Filing Receipt (37 CFR 1.54) will be issued in due course and the date shown on this Acknowledgement Receipt will establish the filing date of the application.</p> <p><u>National Stage of an International Application under 35 U.S.C. 371</u> If a timely submission to enter the national stage of an international application is compliant with the conditions of 35 U.S.C. 371 and other applicable requirements a Form PCT/DO/EO/903 indicating acceptance of the application as a national stage submission under 35 U.S.C. 371 will be issued in addition to the Filing Receipt, in due course.</p> <p><u>New International Application Filed with the USPTO as a Receiving Office</u> If a new international application is being filed and the international application includes the necessary components for an international filing date (see PCT Article 11 and MPEP 1810), a Notification of the International Application Number and of the International Filing Date (Form PCT/RO/105) will be issued in due course, subject to prescriptions concerning national security, and the date shown on this Acknowledgement Receipt will establish the international filing date of the application.</p>					

Neifeld Docket No: SCOT0014-4

Application/Patent No: 11/895,388

USPTO CONFIRMATION NO: 2103

File/Issue Date: 8/24/2007

Inventor/title: Moskowitz/ Data protection method and device

Examiner/ArtUnit: Izunna OKEKE/2432

ENTITY STATUS: SMALL (CONVERT UPON ALLOWANCE TO LARGE)

Priority: Application No. 09/046,627 (which issued July 22, 2003, as U.S. Patent No. 6,598,162)

**37 CFR 1.7(c) FILING RECEIPT AND TRANSMITTAL LETTER WITH
AUTHORIZATION TO CHARGE DEPOSIT ACCOUNT**

1. **THE COMMISSIONER IS HEREBY AUTHORIZED TO CHARGE ANY FEES WHICH MAY BE REQUIRED, OR CREDIT ANY OVERPAYMENT, TO DEPOSIT ACCOUNT NUMBER 50-2106.**

2. **FEES (PAID HEREWITH BY EFS CREDIT CARD SUBMISSION) \$ 310.**

A. CLAIMS FEES

B. OTHER FEES

1402/2402 41.20(b)(2) Filing a brief in support of an appeal 620.00 **310.00**

3. **THE FOLLOWING DOCUMENTS ARE SUBMITTED HEREWITH:**

37 CFR 41.37 APPEAL BRIEF

4. **FOR INTERNAL NEIFELD IP LAW, PC USE ONLY**

acct/ck/No/date/amnt: 6/SCOT0001/1371/5-12-2012/\$310

Firm charge: \$400

INITIALS OF PERSON WHO **ENTERED** ACCOUNTING DATA: RAN

ATTORNEY SIGNATURE (AUTHORIZING DEPOSIT ACCOUNT)

5/12/2012 /RichardNeifeld#35,299/

RICHARD NEIFELD, REG. NO. 35,299

ATTORNEY OF RECORD

Printed: May 14, 2012 (11:44am)

Y:\Clients\SCOT Scott A Moskowitz and Wistaria Trading,

Inc\SCOT0014-4\Drafts\AppealBrief_SCOT0014-4_5-6-2012.wpd

37 CFR 41.37 APPEAL BRIEF

I. 41.37(a)(1) APPEAL BRIEF

(a)(1) Appellant must file a brief under this section within two months from the date of filing the notice of appeal under § 41.31. - The brief is filed within 2 months from the notice of appeal.

II. 41.37(a)(2) FEE

The brief must be accompanied by the fee set forth in § 41.20(b)(2) - The brief is accompanied by the fee set forth in 41.20(b)(2).

III. 41.37(c) CONTENT OF APPEAL BRIEF

(1) Except as otherwise provided in this paragraph, the brief shall contain the following items under appropriate headings and in the order indicated in paragraphs (c)(1)(i) through (v) of this section, except that a brief filed by an appellant who is not represented by a registered practitioner need only substantially comply with paragraphs (c)(1)(i), (c)(1)(ii), (c)(1)(iv), and (c)(1)(v) of this section: The brief contains the items under appropriate headings.

IV. (c)(1)(i) REAL PARTY IN INTEREST

The real party in interest is SCOTT MOSKOWITZ, the named inventor.

V. **(c)(1)(ii) RELATED APPEALS AND INTERFERENCES**

None.

VI. **(c)(1)(iii) SUMMARY OF CLAIMED SUBJECT MATTER**

A concise explanation of the subject matter defined in each of the rejected independent claims, which shall refer to the specification in the Record by page and line number or by paragraph number, and to the drawing, if any, by reference characters. For each rejected independent claim, and for each dependent claim argued separately under the provisions of paragraph (c)(1)(iv) of this section, if the claim contains a means plus function or step plus function recitation as permitted by 35 U.S.C. 112, sixth paragraph, then the concise explanation must identify the structure, material, or acts described in the specification in the Record as corresponding to each claimed function with reference to the specification in the Record by page and line number or by paragraph number, and to the drawing, if any, by reference characters. Reference to the patent application publication does not satisfy the requirements of this paragraph.

Concise explanation appears before each claim, and citations to paragraphs appear in braces {} and **bold** immediately after the corresponding claim recitations.

Claim 32 defines a method that stores in a software application a digital watermark encoding the license code required to activate the software application.

32. (Previously Presented) A computer-based method for modifying software, comprising: {paragraph [0008], "It is also desirable to further modify the underlying structure of an executable computer application such that it is more resistant to attempts at patching and analysis by memory capture."}

receiving, in a computer having a processor and memory, software, wherein said software provides a specified functionality; {"[0056] One method of the present invention is now discussed. When code and data resources are compiled and assembled into a precursor of an executable program the next step is to use a utility application for final assembly of the executable application.."}}

embedding a watermark into said software, using said computer, said watermark encoding at least one first license code, {"[0006] Digital watermarks can be used to mark each individual copy of a digitized work with information identifying...."; "[0008] It is desirable to use a "stega-cipher" or watermarking process to hide the necessary parts or resources of the executable object code in the digitized sample resources. "; "[0013] The present invention includes an application of the technology of "digital watermarks." As described in previous disclosures...."; paragraph [0038], "Instead of providing, or otherwise distributing, watermarked content that is not noticeably altered, a partially "scrambled" copy of the content is distributed. The key is necessary both to register the sought-after content and to descramble the content into its original form."; paragraph [0041], "Similar to on-the-fly decryption operations, the benefits inherent in this embodiment include the fact that the combination of watermarked content security, which is key-based, and the descrambling of the data, can be performed by the same key";

"[0054] The first method of the present invention described involves hiding necessary "parts" or code "resources" in digitized sample resources using a "digital watermarking" process, such as that described in the "Steganographic Method and Device" patent application."; "[0055] Given that there are one or more of these essential resources, what is needed to realize the present invention is the presence of certain data resources of a type which are amenable to the "stega-cipher" process described in the "Steganographic Method and Device" patent U.S. Pat. No. 5,613,004. Data which consists of image or audio samples is particularly useful. Because this data consists of digital samples, digital watermarks can be introduced into the samples.";

"[0056] One method of the present invention is now discussed. When code and data resources are compiled and assembled into a precursor of an executable program the next step is to use a utility application for final assembly of the executable application. The programmer marks several essential code resources in a list displayed by the utility. The utility will choose one or several essential code resources, and encode them into one or several data resources using the stegacipher process. ... This method, then, is to choose the key so that it corresponds, is equal to, or is a function of, a license code or license descriptive information, not just a text file, audio clip or identifying piece of information as desired in digital watermarking schemes extant and typically useful to stand-alone, digitally sampled content. The key is necessary to access the underlying code, i.e., what the user understands to be the application program."; "[0057] The assembly utility can be supplied with a key generated from a license code generated for the license in question. Alternatively, the key, possibly random, can be stored as a data resource and encrypted with a derivative of the license code. Given the key, it encodes one

or several essential resources into one or several data resources."}

thereby resulting in a first license code encoded watermarked software. {"[0057] ... **The application must also contain a data resource which specifies in which data resource a particular code resource is encoded. This data resource is created and added at assembly time by the assembly utility. The application can then operate as follows: [0058] 1) when it is run for the first time, after installation, it asks the user for personalization information, which includes the license code. This can include a particular computer configuration; [0059] 2) it stores this information in a personalization data resource; [0060] 3) Once it has the license code, it can then generate the proper decoding key to access the essential code resources. [0061] Note that the application can be copied in an uninhibited manner, but must contain the license code issued to the licensed owner, to access its essential code resources. The goal of the invention, copyright protection of computer code and establishment of responsibility for copies, is thus accomplished.}**

Claim 40 defines stored machine readable instructions. When executed on a computer system, the instructions store a software application in memory. When the computer system subsequently receives licensing information, the instructions cause the computer system to execute an algorithm using the licensing information to identify a digital watermark in the software application. (As noted elsewhere in our application, the digital watermark can be used to encode information necessary to use the software specified functionality of the application, and identifying the watermark is a precondition to using the information encoded in the watermark.)

40. (Previously Presented) An article of manufacture comprising a machine readable medium, having thereon stored instructions adapted to be executed by a processor of a computer system, said computer system including a memory, which instructions when executed by said computer system result in a process comprising:

said computer system storing a software in said memory; **{"[0058] 1) when it is run for the first time, after installation, it asks the user for personalization information, which includes the license code. This can include a particular computer configuration;"}**

said computer system receiving licensing information as an input and using said licensing information in an algorithm to identify a watermark in said software. **{"[0056]... The utility will choose one or several essential code resources, and encode them into one or several data resources using the stegacipher process."; "[0060] 3) Once it has the license code, it can then generate the proper decoding key to access the essential code resources. [0061] Note that the application can be copied in an uninhibited manner, but must contain the license code issued to the licensed owner, to access its essential code resources. The goal of the invention, copyright protection of computer code and establishment of responsibility for copies, is thus accomplished."}**

Claim 52 defines a computer system that can modify a software application by inter alia embedding a watermark into the software application. The watermark encodes a license code that can activate the software so that the software provides its specified functionality to the end user.

52. (Previously Presented) A computer-based system for modifying software, comprising:

a computer having a processor and memory; {E.g., [0056], "compiled and assembled"} wherein said computer is programmed to receive software that provides a specified functionality when installed on a computer system; {"[0056] **One method of the present invention is now discussed. When code and data resources are compiled and assembled into a precursor of an executable program the next step is to use a utility application for final assembly of the executable application.**"}

wherein said computer is programmed to embed a watermark into said software; {"[0054] **The first method of the present invention described involves hiding necessary "parts" or code "resources" in digitized sample resources using a "digital watermarking" process,...."**}

wherein said watermark encodes at least one first license code, {"[0056] **... The utility will choose one or several essential code resources, and encode them into one or several data resources using the stegacipher process.**"; "[0057] **The assembly utility can be supplied with a key generated from a license code generated for the license in question.**"}

thereby resulting in a first license code encoded watermarked software. {"[0057] **The assembly utility can be supplied with a key generated from a license code generated for the license in question.**"; "[0057] **... The application can then operate as follows: [0058] 1) when it is run for the first time, after installation, it asks the user for personalization information, which includes the license code. This can include a particular computer configuration; [0059] 2) it stores this information in a personalization data resource; [0060]**"}

3) Once it has the license code, it can then generate the proper decoding key to access the essential code resources."}

Claim 58 defines a method for using a software product. The application is loaded on a computer. Upon receiving license information, the loaded software product executes a routine to decode a first license code encoded in the software, using the license information.

58. (Previously Presented) A method for licensed software use, the method comprising:

loading a software product on a computer, said computer comprising a processor, memory, an input, and an output, so that said computer is programmed to execute said software product;

said software product outputting a prompt for input of license information; and {"0058]

1) when it is run for the first time, after installation, it asks the user for personalization information, which includes the license code."}

said software product using license information entered via said input in response to said prompt in a routine designed to decode a first license code encoded in said software. {"0055]

Given that there are one or more of these essential resources, what is needed to realize the present invention is the presence of certain data resources of a type which are amenable to the "stega-cipher" process described in the "Steganographic Method and Device" patent U.S. Pat. No. 5,613,004. "; "[0060] 3) Once it has the license code, it can then generate the proper decoding key to access the essential code resources. "}

Claim 59 defines a method for encoding software. The method uses a computer that encodes a first license key into software code, using an encoding algorithm.

59. (Previously Presented) A method for encoding software code using a computer having a processor and memory, comprising:

storing a software code in said memory; **{ "[0056] One method of the present invention is now discussed. When code and data resources are compiled and assembled into a precursor of an executable program the next step is to use a utility application for final assembly of the executable application." }**

wherein said software code comprises a first code resource and provides a specified underlying functionality when installed on a computer system; and **{ "[0054]...The basic premise for this scheme is that there are a certain sub-set of executable code resources, that comprise an application and that are "essential" to the proper function of the application. "**

encoding, by said computer using at least a first license key and an encoding algorithm, said software code, **{ "[0057] The assembly utility can be supplied with a key generated from a license code generated for the license in question." ; "[0056] ... The utility will choose one or several essential code resources, and encode them into one or several data resources using the stegacipher process." }**

to form a first license key encoded software code. **{ [0056]..."The purpose of this scheme is to make a particular licensed copy of an application distinguishable from any other. It is not necessary to distinguish every instance of an application, merely every**

instance of a license."; "[0060] 3) Once it has the license code, it can then generate the proper decoding key to access the essential code resources."}

Claim 61 defines a method for encoding software. The method modifies the software code by encoding a first code resource.

61. (Previously Presented) A method for encoding software code using a computer having a processor and memory, comprising:

storing a software code in said memory; **{ "[0056] One method of the present invention is now discussed. When code and data resources are compiled and assembled into a precursor of an executable program the next step is to use a utility application for final assembly of the executable application" }**

wherein said software code comprises a first code resource and provides a specified underlying functionality when installed on a computer system; and **{ "[0052] The memory address of the first instruction in one of these sub-objects is called the "entry point" of the function or procedure. The rest of the instructions comprising that sub-object immediately follow from the entry point. Some systems may prefix information to the entry point which describes calling and return conventions for the code which follows, an example is the Apple Macintosh Operating System (MacOS). These sub-objects can be packaged into what are referred to in certain systems as "code resources," which may be stored separately from the application, or shared with other applications, although not necessarily. Within an application there are also data objects, which consist of some data to**

be operated on by the executable code. These data objects are not executable. That is, they do not consist of executable instructions. The data objects can be referred to in certain systems as "resources."}

modifying, by said computer, using a first license key and an encoding algorithm, said software code, to form a modified software code; and

wherein said modifying comprises encoding said first code resource to form an encoded first code resource; **{ "[0054] The first method of the present invention described involves hiding necessary "parts" or code "resources" in digitized sample resources using a "digital watermarking" process, such as that described in the "Steganographic Method and Device" patent application." }**

wherein said modified software code comprises said encoded first code resource, and a decode resource for decoding said encoded first code resource; **{ "[0057] ... Note further that the application contains a code resource which performs the function of decoding an encoded code resource from a data resource." }**

wherein said decode resource is configured to decode said encoded first code resource upon receipt of said first license key. **{ The application must also contain a data resource which specifies in which data resource a particular code resource is encoded. This data resource is created and added at assembly time by the assembly utility. The application can then operate as follows: [0058] 1) when it is run for the first time, after installation, it asks the user for personalization information, which includes the license code. This can include a particular computer configuration; [0059] 2) it stores this information in a personalization data resource; [0060] 3) Once it has the license code, it can then generate**

the proper decoding key to access the essential code resources."}

Claim 62 defines a method of encoding software. The method encodes a software code interrelationship between code resources of the software.

62. (Previously Presented) A method for encoding software code using a computer having a processor and memory, comprising:

storing a software code in said memory; **{"[0056] One method of the present invention is now discussed. When code and data resources are compiled and assembled into a precursor of an executable program the next step is to use a utility application for final assembly of the executable application"}**

wherein said software code defines software code interrelationships between code resources **{"[0052] The memory address of the first instruction in one of these sub-objects is called the "*entry point*" of the function or procedure. The rest of the instructions comprising that sub-object immediately follow from the entry point. Some systems may prefix information to the entry point which describes calling and return conventions for the code which follows, an example is the Apple Macintosh Operating System (MacOS). These sub-objects can be packaged into what are referred to in certain systems as "*code resources*," which may be stored separately from the application, or shared with other applications, although not necessarily."}**; **{"[0065] Once the code resources of a program are loaded into memory, they typically remain in a fixed position..."}**

that result in a specified underlying functionality when installed on a computer system;
and

encoding, by said computer using at least a first license key and an encoding algorithm,
said software code, {"[0057] **The assembly utility can be supplied with a key generated from
a license code generated *for the license in question.***"; "[0056] ... **The utility will choose one
or several essential code resources, and encode them into one or several data resources
using the stegacipher process.**"}

to form a first license key encoded software code {[0056]...**"The purpose of this
scheme is to make a particular licensed copy of an application distinguishable from any
other. It is not necessary to distinguish every instance of an application, merely every
instance of a license."**; "[0060] 3) **Once it has the license code, it can then generate the
proper decoding key to access the essential code resources.**"}

in which at least one of said software code interrelationships are encoded. "[0057] ...
**The application must also contain a data resource which specifies in which data resource a
particular code resource is encoded. This data resource is created and added at assembly
time by the assembly utility.**"; "[0066] **Under the present invention, the application
contains a special code resource which knows about all the other code resources in
memory. During execution time, this special code resource, called a "memory scheduler,"
can be called periodically, or at random or pseudo random intervals, at which time it
intentionally shuffles the other code resources randomly in memory, so that someone
trying to analyze snapshots of memory at various intervals cannot be sure if they are
looking at the same code or organization from one "break" to the next.**" }

Claim 63 defines a method for encoding software code twice, each having a different license key encoded therein.

63. (Previously Presented) A method for encoding software code using a computer having a processor and memory, comprising:

storing a software code in said memory; **{ "[0056] One method of the present invention is now discussed. When code and data resources are compiled and assembled into a precursor of an executable program the next step is to use a utility application for final assembly of the executable application" }**

wherein said software code provides a specified underlying functionality when installed on a computer system;

encoding, by said computer using at least a first license key and an encoding algorithm, said software code, **{ "[0057] The assembly utility can be supplied with a key generated from a license code generated for the license in question." ; "[0056] ... The utility will choose one or several essential code resources, and encode them into one or several data resources using the stegacipher process." }**

to form a first license key encoded software code; code **{ [0056] ... "The purpose of this scheme is to make a particular licensed copy of an application distinguishable from any other. It is not necessary to distinguish every instance of an application, merely every instance of a license." ; "[0060] 3) Once it has the license code, it can then generate the proper decoding key to access the essential code resources." }**

encoding, by said computer using at least a second license key and an encoding

algorithm, said software code, to form a second license key encoded software code; {[0056] ...**The purpose of this scheme is to make a particular licensed copy of an application distinguishable from any other. It is not necessary to distinguish every instance of an application, merely every instance of a license.**"}; {[0057] **The assembly utility can be supplied with a key generated from a license code generated for the *license in question.***"} }

wherein said first license key encoded software code is not identical to said second license key encoded software code if said first license key is not identical to said second license key. {[0056] ... "**merely every instance of a license**"}

CHANGE IN RULES.

As noted in the final rule change, at 76 FR 72271, "For example, statements of the status of claims, the status of amendments, and the grounds of rejection to be reviewed on appeal are no longer required in the appeal brief (final Bd.R. 41.37) or in the examiner's answer." That change is effective to this appeal, since the effective date is for all appeals filed after 1/23/2012.

VII. 37 CFR 41.37(c)(1)(iv) ARGUMENT

(iv) Argument. The arguments of appellant with respect to each ground of rejection, and the basis therefor, with citations of the statutes, regulations, authorities, and parts of the Record relied on. The arguments shall explain why the examiner erred as to each ground of rejection contested by appellant. Except as provided for in §§ 41.41, 41.47 and 41.52, any arguments or authorities not included in the appeal brief will be refused consideration by the Board for

purposes of the present appeal. Each ground of rejection contested by appellant must be argued under a separate heading, and each heading shall reasonably identify the ground of rejection being contested (e.g., by claim number, statutory basis, and applied reference, if any). For each ground of rejection applying to two or more claims, the claims may be argued separately (claims are considered by appellant as separately patentable), as a group (all claims subject to the ground of rejection stand or fall together), or as a subgroup (a subset of the claims subject to the ground of rejection stand or fall together). When multiple claims subject to the same ground of rejection are argued as a group or subgroup by appellant, the Board may select a single claim from the group or subgroup and may decide the appeal as to the ground of rejection with respect to the group or subgroup on the basis of the selected claim alone. Notwithstanding any other provision of this paragraph, the failure of appellant to separately argue claims which appellant has grouped together shall constitute a waiver of any argument that the Board must consider the patentability of any grouped claim separately. Under each heading identifying the ground of rejection being contested, any claim(s) argued separately or as a subgroup shall be argued under a separate subheading that identifies the claim(s) by number. A statement which merely points out what a claim recites will not be considered an argument for separate patentability of the claim.

VII.A ARGUMENT SUMMARY

Summary - The claims have various combinations of limitations, none of which are suggested by the prior art. Each such combination is discussed below. Reasons why the rejection of each claim are improper (why the examiner erred) follow in each claim group discussion.

This application discloses a brilliant, pioneering invention. Instead of merely requiring entry of a license code into an instance of a software product in order to activate that instance of the software product, this invention encodes the corresponding required license code, into that instance of the software product. Preferably encoding in a digital watermark. Thus, even if that instance of the software product could be "cracked" and made to function without entry of the corresponding license code, the "cracked" version would still identify the required license code, providing an indication of ownership. That would provide an electronic trail facilitating determining who or where the illegal copying/cracking occurred.

Moreover, this application discloses linking information embedded in the watermark to the functionality of that instance of the software product such that any destruction of the watermark (in an attempt to prevent identification of the illegal copying) would result in the software product remaining nonfunctional. Thus, the disclosed invention enables both unique identification of each instance of a software product and ties function of the software product to the unremovable presence of the license identifying information contained in the watermark.

Modifying a software application to include a watermark encoding the license code for that software application to function, in the software application, is inventive. Functionally linking the "activation" of that software application to the information stored in the watermark, such that the software application does not function until a user enters the license code corresponding to the information stored in the watermark, is inventive. The application discloses that concept and explains how to effect it.

The basis for the obviousness rejection are (1) an overly broad interpretation of the claims and (2) misunderstanding of what the art teaches. For some claims, no explanation in the

office action appealed from seems to exist as to why these claims were rejected.

VII.B STATUS OF ALL CLAIMS, REJECTION, ISSUES

Claims 1-31 are canceled. Claims 32-45 are pending and rejected. Claims 46-51 are canceled. Claims 52-64 are pending and rejected.

The appellant appeals the rejection of all pending claims (claims 32-45 and 52-64) under 103 based upon Holmes (US-5287407), and further in view of Houser et al. (US-5606609).

Issues: Whether the rejection of any claim under 103 based upon Holmes (US-5287407), and Houser (US-5606609) is proper.

As required by the revised rule 41.37, each heading below includes claim number, statutory basis, and applied reference, if any, and list of claims to which the reasoning applies.

VII.C CLAIM 32, 103 REJECTION, HOLMES AND HOUSER , (CLAIMS 32-40)

The examiner erred by improperly construing the claims, mischaracterizing the prior art, and drawing improper conclusion regarding motivation to modify Holmes based upon Houser and knowledge of one of ordinary skill in the art.

Claim 32, the prosecution history relevant to claim 32, claim construction based upon the specification and the prosecution history relevant to claim 32, and then reasons why the rejection of claim 32 is improper, appear in that order, in the subsections below.

CLAIM 32 RECITATION

Claim 32 under appeal reads:

32. (Previously Presented) A computer-based method *for modifying software*, comprising:
receiving, in a computer having a processor and memory, software,
wherein *said software provides a specified functionality*;
embedding a watermark into said software, using said computer, *said watermark encoding at least one first license code*, thereby resulting in a first license code encoded watermarked software.

PROSECUTION HISTORY FOR CLAIM 32

Copied in below is the prosecution history of claim 32. This history relevant to understanding claim 32 and the obviousness issue now on appeal.

On 8-24-2007, the applicant filed the following claim numbered 32:

32. (new) A method for copy protection of software comprising: embedding the software with a watermark wherein the embedded software operates in a manner substantially the same as the software prior to the embedding step.

On 10-19-2007, that claim was re-presented.

On 11-10-2009, the USPTO issued a restriction requirement including group II, which read as follows: "II. Claims 32-45 and 52-57, drawn to protecting data or software by *inhibiting*

the unauthorized installation or use of software, classified in class 7 13, subclass 176.” Bold and italics added for emphasis.

On 10-10-2009, the applicant provisionally elected group II.

On 4-5-2010, the USPTO issued an office action, non-final rejection, rejection claim 32 for double patenting over claims of application 08587943, under 101, 112 first paragraph, and 102 based upon Moore 6067622.

On 6-8-2010, the USPTO issued an examiner interview summary noting that the applicant had asserted that “Moore obtains his key from a call purveyor.”

On 9-3-2010, the applicant filed a response. The response included an amended claim numbered 32, marked as follows to show changes:

32. (Currently Amended) A computer-based method for ~~copy~~
~~protection of software~~ modifying software , comprising:
receiving, in a computer having a processor and memory, software,
wherein said software provides a specified functionality;
embedding ~~the software with~~ a watermark into said software, using said
computer, said watermark encoding at least one first license code, thereby
resulting in a first license code encoded watermarked software, wherein ~~the~~
~~embedded software operates in a manner substantially the same as the software~~
~~prior to the embedding step~~ said first license code encoded watermarked software.

The applicant’s response to the double patenting rejection requested clarification, stating

in part “that 08/587,943 issued long ago, as USP 5,745,569.”

The applicant’s response the 101 rejection stated that “the claims have been amended to define patentable subject matter by referring to use of computer components in performing processing steps, and by referring to functionality relating to implementation on a computer.”

The applicant’s response to the 112 first paragraph rejection stated that the “OA items 5-6 rejects claim 32 under the first paragraph of 35 USC 112 first paragraph for lack of disclosure in the specification of the recitation 'wherein the embedded software operates in manner substantially the same as software prior to the embedding step' indicating that 'substantially' was not disclosed in the specification. In response, claim 32 has been amended and, as amended, no longer contains that recitation.”

The applicant’s response to the 102 rejection over Moore stated “OA item 9 rejects claims 32-45 and 52-69 under 35 USC 102 based upon Moore US patent 6067622. The OA cites Moore Fig. 1a and 8:43-5 1, which disclose a code module, not a watermark. In response, the claims have been amended to clearly define an invention not disclosed by Moore. Moore discloses a copyright module, not watermarking, and in any case does not disclose encoding a license key in software, using license information to identify a watermark in software, or decoding software using license information. In contrast, the independent claims define these concepts, which are not disclosed or suggested by Moore”.

On 11-26-2010, the USPTO issued a final office action (FOA).

This FOA rejected claim 32 for double patenting over claims of USP 5745569.

This FOA objected to claim 32, stating “Claim 32 recites in part; ‘thereby resulting in a first license code encoded watermarked software, wherein said first license code encoded

watermarked software'. The last part of the limitation implies that the license code encoded the watermarked software. This recitation is inconsistent with the disclosure in the specification. Applicant is asked to review the claim with respect to the limitations presented."

This FOA rejected claim 32 under 102 based upon Houser, USP 5606609, stating the rejection as follows:

3. Claims 32-45 and 52-61 are rejected under 35 U.S.C. 102(e) as being anticipated by Houser et al. (US-5606609).

a. Referring to claim 32, 40, 45, 52 and 59:

Regarding claim 32, 40, 45, 52 and 59, Houser teaches a computer-based method for modifying software, comprising: receiving- , in a computer having- a processor and memory, software, wherein said software provides a specified functionality (Col 7, Line 15-28.. . electronic document software), embedding a watermark into said software, using said computer, said watermark encoding at least one first license code, thereby resulting-in a first license code encoded watermarked software, wherein said first license code encoded watermarked software (Col 7, Line 30-60.. . embedding a watermark into the electronic document wherein the watermark comprises a license security code thereby resulting a licensed security code encoded watermarked document).

On 2-28-2011, the applicant filed a response. The response included an amended claim numbered 32, marked as follows to show changes:

32. (Currently Amended) A computer-based method for modifying software, comprising:

receiving, in a computer having a processor and memory, software, wherein said software provides a specified functionality;

embedding a watermark into said software, using said computer, said watermark encoding at least one first license code, thereby resulting in a first license code encoded watermarked software; ~~wherein said first license code encoded watermarked software.~~

In response to the double patenting rejection, the applicant's response stated that:

DOUBLE PATENTING REJECTION OVER USP 5,745,569

OA page 3 item 2 rejects claims 32-45 and 52-64 based upon claims 1-20 of USP 5,745,569. The OA reasons that claims herein are obvious over claims of USP 5,745,569 because claims of USP 5,745,569 define "a method of copy protecting a software or digital data *wherein a license is watermarked into the software* and a license key used to decode/access the watermark to enable authorized use of the software."

OA page 5 lines 14-16.

In response, first, please note that claims of USP 5,745,569 do not define "*a license is watermarked into the software.*" In contrast, in this application: independent claim 32 recites "a license is watermarked into the software"; independent claim 52 recites "wherein said watermark encodes at least one first

license code";

independent claim 58 recites "a first license code encoded in said software";

independent claim 59 recites "form a first license key encoded software code";

independent claim 61 recites "modifying, by said computer, using a first license key and an encoding algorithm, said software code, to form a modified software code";

independent claim 62 recites "encoding, by said computer using at least a first license key and an encoding algorithm, said software code, to form a first license key encoded software code "; and

independent claim 63 recites "encoding, by said computer using at least a first license key and an encoding algorithm, said software code, to form a first license key encoded software code".

In response, second, please note that claims of USP 5,745,569 do not define "identifying a watermark in software". In contrast, in this application, independent claim 40 defines "using said licensing information in an algorithm to identify a watermark in said software".

For the foregoing reasons, the applicant submits that the double patenting rejection based upon claims 1-20 of USP 5,745,569 is improper and should be reversed.

The applicant's response to the objection to claim 32 stated that "In response to the objection to claim 32, the applicant deletes the surplusage text "~~wherein said first license code~~

~~encoded watermarked software" recitation."~~

The applicant's response to the rejection under 102 based upon Houser, stated that:

102(E) REJECTIONS BASED UPON US 5606609 TO HOUSER

OA page 5 item 3 rejects claims 32-45 and 52-61 under 102(e) based upon US 5606609 to Houser. In response, the applicant traverses for the following reasons.

Claim 32 recites "embedding a watermark into said software, using said computer, said watermark encoding at least one first license code, thereby resulting in a first license code encoded watermarked software." A watermark in this art refers to information embedded into a digital signal in a way that is difficult to remove. Regarding the meaning of "software", our specification states that: "[0033] An improvement over the art is disclosed in the present invention, in that the software itself is a set of commands, compiled by software engineer, which can be configured in such a manner as to tie underlying functionality to the license or authorization of the copy in possession by the user. Without such verification, the functions sought out by the user in the form of software cease to properly work. Attempts to tamper or "patch" substitute code resources can be made highly difficult by randomizing the location of said resources in memory on an intermittent basis to resist most attacks at disabling the system."

Houser does not disclose claim 32's "embedding a watermark into said software".

First, Houser does not disclose embedding into "software". Houser col. 7 lines 19-21 clarify that an "application" generates an "electronic document". An application defines software. An electronic document defines a data file in a format readable by some software. As noted in Houser in connection with the discussion of the interrelationship of the electronic document to the embedded object, "As seen in FIG. 5, an electronic document 510 may be a text file created by any conventional application, as noted above."

The OA at page 5 item 3a corresponds Houser's data file with the claim 32's "software", which is incorrect because Houser's data file is not software, it is data. Accordingly, Houser does not anticipate.

Second, Houser does not disclose a "watermark" being embedded. It discloses only an object being embedded at a specified location in the electronic document. The OA cites Houser 7:30-60 for disclosing a watermark. However, Houser 7:30-60 does not disclose a watermark. Houser 7:30-60 contains no details about the relationship of the data defining the embedded object to the data defining the electronic document.

Houser Fig. 5, and 11:52 to 12:39 provide Houser's description of embodiments of the embedded object in the electronic document. Each of these embodiments relies upon the location of the object being predetermined and definite. In this regard, Houser notes that "FIG. 5 illustrates an electronic document having security objects embedded therein in accordance with the present invention." In describing the embedded object, Houser further notes that

"In general, the security object may be embedded at any location within or appended to the electronic document. Different applications used to create the electronic document 510 may handle OLE security objects in different ways. For example, the OLE security object may be inserted in its entirety into the electronic document. FIG. 5 illustrates an example of an OLE security object 520 inserted into the document 510. A OLE object 530 is included in electronic document 510 to illustrate that the document may include multiple OLE security objects." Thus, Houser generally contemplates a embedding an object at "any location" meaning a defined location within the document. An object embedded at a predetermined and definite single location within an electronic document is not a watermark. Accordingly, Houser does not anticipate claim 32.

On 3-18-2011, the USPTO issued an examiner interview summary which noted that "Applicant's repres[e]ntative discussed claim 32 with reference to the applied reference and explained that the reference fails to teach a watermark which encodes a license code."

On 4-1-2011, the USPTO issued a new non final office action. This office action presented only the following rejection of claim 32, under 103, based upon a combination of Holmes, USP 5287407 and Houser, USP 5606609:

7. Claims 32-45 and 52-64 are rejected under 35 U.S.C. 103(a) as being unpatentable over Holmes et al. (US-5287407), and further in view of Houser et al. (US-5606609).

a. Referring to claims 32, 40, 41, 45, 52, 55, 58 and 59:

Regarding claims 32, 40, 41, 45, 52, 55, 58 and 59, Holmes teaches a computer-based method for modifying software, comprising: receiving, in a computer having a processor and memory, software, wherein said software provides a specified functionality (Col 1, Line 60 thru Col 2, Line 4 and Line 10-20 and Col 3, Line 38-45 and Col 3, Line 67 thru Col 4, Line 4 ... method for modifying software which provides a specified functionality when executed by embedding a code in the software such as a unique identifying data (which could serve as a license for the software) associated with a user or the system or the software)

Holmes teaches embedding an identification data into the software.

Holmes does not teach embedding the data as a watermark. However, embedding information as an electronic watermark is well known in the art. For instance, Houser teaches embedding information as a digital watermark into a media (See Houser, Col 16, Line 59-65 electronically watermarked graphic/video file). Therefore, one of ordinary skill in the art would have been motivated to modify Holmes' teaching by embedding the identification data as a watermark wherein the watermark cannot be forged and is also difficult to remove for the purpose of protecting the watermarked software and preventing unauthorized users from tampering with the identification data.

On 7-1-2011, the applicant filed a response. The applicant's response to the 103 rejection

of claim 32 based upon Houser and Holmes stated that:

CLAIMS 32-45 AND 52-64 UNDER 103(A) BASED UPON HOLMES, USP 5287407 AND HOUSER, USP 5606609.

In response OA items 6-7, we respectfully traverse because Holmes and Houser do not suggest our claimed invention. In fact, Holmes is not relevant.

Regarding claim 32, note that the specification indicates that a particular license code is what is required to be input into a system running a particular software object encoded with a key corresponding to that license code, in order to allow the system to use the functionality of the software. See [0056]-[0057]. Claim 32 defines, in relevant part, a *method of modifying software*. As claimed, this method comprises "embedding a watermark *into said software*, using said computer, *said watermark encoding at least one first license code*, thereby resulting in a first license code encoded watermarked software".

In rejecting claim 32, the OA states that Holmes teaches embedding in software a "unique identifying data" that is "associated with a user or the system or the software." The OA also assumes that this embedded identifying data that "could serve as a license for the software." The OA does not assert any reference teaches using the embedded identifying data as a license for the software. The OA does not assert Holmes teaches entering the identifying data into a system in order to use the functionality of software.

What Holmes actually teaches is clear from its abstract, which states that:

"A master copy of a software file has within it a predetermined block of data. When a copy of the file is made that block of data within the copied file is located and overwritten with data identifying the copied file. When an unauthorized copy is found, the data identifying the copy can be read and the source of the unauthorized copy may be traced." Holmes clearly distinguishes data from code, and discloses, only, inserting data identifying the copied file into "predetermined block of data". Holmes does not disclose modifying software code, only changing data in a data block of a "file". This data "block" means a sequential set of values. Cf. description of Fig. 1, "block 8 contains a predetermined sequence of code, in this example represented by `AAAAAA`."

Holmes teaches embedding in a data *file*, or a software *file* a unique identifying data that is associated with a user or the system or the software. (Holmes states " However, in preferred embodiments of the invention said data identifying said copy file includes one or more items of data identifying the time at which said copy file was made, the authorized user of said copy file, said first data processing system and/or said second data processing system.")

The applicant notes that Holmes contain no mention of license, activation, or the like, relating to license codes for software. Holmes does not suggest that its embedded identifying data "could serve as a license for the software." Moreover, Holmes teaches away from that concept by going out of its way to point out that presence or absence of the predetermined block of data in a software file does not affect its functionality:

Another advantage of the system is that a software file may be produced by a software vendor to include the predetermined block of data, but use of that file will not require use of the technique of the invention. Accordingly, the same software file can be used in systems which do or do not implement the invention. The particular combination of elements comprising the invention provides a security technique which is surprisingly simple to implement and effective in use. ... Furthermore, producers of software files can include within them the necessary predetermined block of data which can be used to mark files distributed within the network, and yet, if desired, the same version of the software file can be copied and distributed by conventional techniques without using the invention.

The way Holmes accomplishes this is by *predetermining the location of the data block in its file*, and then only overwriting data *in that location in the file* with data unique to each copy, as stated in the description of its Figure 1, noting the reference to "*in the same position*":

FIG. 1 shows a master file 6 stored within a first data processing system 2. The master file 6 has embedded somewhere within it a predetermined block of data 8. The block 8 does not play any part in the function of the software of the master file itself; rather its function is to provide a locatable space within the

master file in which data identifying a copied file may be written.

The block 8 contains a predetermined sequence of code, in this example represented by `AAAAAA`.

A copy of the master file 6 is then transmitted to a second data processing system 4 which stores it as copied file 10. The block 8 is copied with the rest of the master file 6 and so the copied file 10 also contains a block 8 *in the same position* as the block 8 within the master file 6.

Thus, all Holmes teaches is encoding a data block at a predetermined location in any file, with data unique to each copy. Whether the rest of the file is software or data is irrelevant, because this predetermined location is functionally disconnected from the surrounding locations in the same file, whether they are data or software.

In rejecting claim 32, the OA assumes that Houser suggests modifying Holmes to embed identification data as a watermark. *However, Holmes specifically teaches containing the identifying data to a predetermined location in a file*, that is relative for example to the location of the start of the file.

Modifying Holmes to place a "watermark" in that predetermined location in the file is not what claim 32 defines. First, claim 32 recites "A computer-based method for *modifying software*". While Holmes teaches modifying a *file* containing software by changing non functional identifying data contained in the *file*, Holmes does not teach modifying the underlying functionality of the

software. Claim 32's preamble does.

Assuming the OA suggests modifying Holmes in view of Houser to move the identifying data from its predetermined location to unspecified locations, there is no legal motivation to do that, for two reasons.

First, as already noted, such a modification would destroy the only utility that Holmes provides, which is to allow for identification of a file without affecting the data or code otherwise contained in the file. Replacing the predetermined location identifying data in Holmes with a watermark distributed elsewhere in the Holmes data file other than in just the predetermined location, would preclude the easy identification noted in Holmes.

Second, replacing the predetermined location identifying data in Holmes with a watermark distributed elsewhere in the Holmes data file other than in just the predetermined location, lacking the teachings of our invention, would also fatally affect functionality of any software elements contained in the modified file. This is because such a watermarking would change the intra-relationships in, as well as the inter-relationships between, code elements of software in the file. First, the watermarking of Holmes file, if present outside of the predetermined location, would introduce random values at locations inside of what we refer to as "code elements", those sets of instructions for a function, for which we teach such random values would "very likely to 'break' the function" [[0057]. Destroying intra-relationships. This would destroy the functionality of the software. Second, the watermarking would also change the inter-relationships of relative memory

location between distinct code elements, thereby prevent them from function as intended because their relative memory locations would change in a manner not accounted for by each code resource. That would defeat the purpose of Holmes of preserving (data values in a pure data file or) software functionality, in a file otherwise identified by Holmes identity data.

And there is nothing in either Holmes or Houser suggesting, as is taught in the present application, how to watermark throughout a software application, without destroying the functionality of the underlying application. Accordingly, there is no motivation to modify Holmes in view of Houser. We note that, in contrast, as explained above, we do teach an encoding that does not destroy the fundamental code resources by not changing code resources, during encoding.

The rejections of all claims is based upon the flawed combination of Holmes and Houser. Insofar as the foregoing explanation unequivocally shows that the rejection of all claims is improper, no further arguments need be presented. However, it is likely that all additional basis for rejection for obviousness also contain additional flaws, given the fundamental flaws in the base reasoning just described.

On 9-20-2011, the USPTO issued a second final office action (second FOA). The second FOA again rejected claim 32, only under 103. The 103 rejection was again based upon a combination of Holmes, USP 5287407 and Houser, USP 5606609. The examiners reasoning in this second FOA in support of the rejection is copied in below. However, it apparently only

differs from the reasoning in the immediately prior office action by referring to this second FOA's "response to arguments", identified in bold and italics, in the following quotation.

4. Claims 32-45 and 52-64 are rejected under 35 U.S.C. 103(a) as being unpatentable over Holmes et al. (US-5287407), and further in view of Houser et al. (US-5606609).

a. Referring to claims 32, 40, 41, 45, 52, 55, 58 and 59:

Regarding claims 32,40,41,45, 52, 55, 58 and 59, Holmes teaches a computer-based method for modifying software, comprising: receiving, in a computer having a processor and memory, software, wherein said software provides a specified functionality (*See the response to arguments and* Col 1, Line 60 thru Col2, Line 4 and Line 10-20 and Col3, Line 38-45 and Col 3, Line 67 thru Col4, Line 4. . . method for modeling software which provides a specified functionality when executed by embedding a code in the software such as a unique identifying data (which could serve as a license for the software) associated with a user or the system or the software)

Holmes teaches embedding an identification data into the software.

Holmes does not teach embedding the data as a watermark. However, embedding information as an electronic watermark is well known in the art. For instance, Houser teaches embedding information as a digital watermark into a media (See Houser, Col 16, Line 59-65 electronically watermarked graphical video file). Therefore, one of ordinary skill in the art would have been motivated to modify

Holmes' teaching by embedding the identification data as a watermark wherein the watermark cannot be forged and is also difficult to remove for the purpose of protecting the watermarked software and preventing unauthorized users from tampering with the identification data.

In this second FOA, the portion of the "response to arguments" section relating to the rejection of claim 32 under 103, including the emphasis in the original, reads as follows:

1. Applicant's arguments filed 07/01/2011 have been fully considered but they are not persuasive.

With respect to claim 32, applicant argues that the combination of Holmes and Houser fails to anticipate the independent claim. In making this argument, applicant dwells on language in the specification which is not recited in the claims. The claims (which are what is being examined) recite subject matter which is very broad when compared to the arguments presented. For instance, on page 6 of the remarks, applicant argues that "the specification indicates that a particular license code is what is required to be input into a system running a particular software object ". In contrast, claim 32 recites in part, "said watermark encoding at least one first license code, thereby resulting in a first license code encoded watermarked software". Contrary to applicant's argument, the claim does not recite/require a particular license code (type, version, etc) or a particular software object (type, version, etc). Instead, the claims only recite the

general terms 'software' and 'license code'. Furthermore, on Page 8 of the remark, applicant asserts that claim 32's preamble recites/teaches modifying the underlying functionality of the software. Examiner notes that claim 32's preamble recites "a computer-based method for modifying software". This language is quite different in scope from applicant's assertion in that "modifying software" is much broader than "modifying the underlying functionality of the software". With this in mind, let's consider claim 32 with respect to its language and scope and then consider the rejection (combination of Holmes and Houser) presented in the last office action. Claim 32 recites a method for modifying software wherein the software has a specified functionality. The software is modified by embedding a watermark in the software wherein the watermark contains (encodes) a license code thereby making the software a license code watermarked software. Holmes teaches a software file which has a specified functionality and has embedded within it a block of data code. The block of embedded code serves as a license code to provide identifying data for the software file. Holmes doesn't teach embedding the block of identification code as a watermark but Houser which teaches embedding codes in software as a watermark was used to remedy the teaching of Holmes with the rationale that embedded watermarks are difficult to forge and remove. (See the rejection to claim 32 in the last office action). Therefore, with respect to the language and scope of independent claim 32, the combination of Holmes and Houser fully anticipates the claim. The rest of the argument presented with respect to the teachings (prior arts) of Holmes and

Houser are quite irrelevant because the claims do not recite the argued points. For instance, "the type of license code", "the location of the data block", etc. In view of the explanation above, examiner maintains the rejection because the claim as presented is fully anticipated by the combination of Holmes and Houser as outlined in the 35 U.S.C. 103 rejection below.

On 1-23-2012, the applicant sent an email to examiner of this application at his USPTO email address stating in relevant part that:

You have indicated, by identifying in item 1 in the OA, that these claims do not define : "particular license code"; "particular software object"; or "modifying the underlying functionality or the software" and therefore you have maintained the rejections over prior art. I have asked you via telephone to let me know whether clarifying the independent claims do define these limitations will overcome the prior art rejections. The purpose of the interview is to determine if that is the case, and if so, suitable claim language for amendment.

On 2-2-2012, the USPTO issued an interview summary, which stated that:

Applicant's representative wanted to know if amendment of the independent claim will overcome the rejection of record. Examiner replied that an amendment has to be received/filed and a search updated before determining if

the amendment overcomes the rejection of record. In the absence of an amendment or amended claim limitations, there is no way to determine if the rejection has been overcome. No agreement with respect to the claims was reached.

Here ends the prosecution relevant to claim 32.

WHY CITATIONS HEREIN BELOW ARE TO PARAGRAPHS, NOT PAGES

The application (11895388) filed 8-24-2007 includes a specification having 68 numbered paragraphs on 22 unnumbered pages. On 1-17-2008, the USPTO publication that application with publication number 20080016365. The specification of the publication also has 68 numbered paragraphs. Because the application as filed did not contain page numbering and did contain paragraph numbering, the appellant refers herein below to the paragraph numbering (common to the application as filed and its publication). Moreover, newly revised rule 41.37 authorizes citations in briefs, to paragraph numbers.

SUPPORT FOR AND CONSTRUCTION OF CLAIM 32

Claim 32 requires construction because "modifying software"; "specified functionality"; "watermark"; "embedding"; and "watermark encoding" all have meanings tied to the specification and/or are terms of art in this field.

A fundamental point is that our application discloses an invention using digital watermarking, for encoding information. The examiner did not dispute that conclusion.

However, we need to make it clear to the Board in understanding the claims, including claim 32, that the claims must be construed in light of the unequivocal digital processing nature of this invention. Hence, we show below why the specification and phrases in claim 32 referring to software, computer, watermark, and embed require claim 32 be construed to be a method generating a digital watermark.

POINT OF LAW ON CITATION TO DICTIONARY DEFINITIONS

Note that citation to dictionary definitions is not improper submission of evidence after notice of appeal. USPTO precedent holds that an appeal brief is NOT, "non compliant", merely for newly citing dictionary definitions in an appeal brief. See Ex parte Scroggie, Decision on Petitions, dated 7-18-2008, mailed 7-22-2008, in application 09/401,939. That decision stated in relevant part:

DECISION

In view of the foregoing, the First and Second Petitions are DISMISSED as moot.

The appeal process will proceed with Appellants' position being presented by the Second Replacement Brief and the Reply Brief, filed April 6,2007, and the Examiner's position being presented by the Examiner's Answer, entered February 27, 2007. The merits panel to which this appeal is assigned for decision is authorized to consider, to the extent it may be relevant, Appellants' statement in the Original Brief, p. 1 5, that:

A voucher means "a document that provides supporting evidence for a claim, e.g. a receipt proving that a purchase was made." See for example:

<http://encarta.msn.codencnet/features/dictionary/DictionaryResult~.aspx?refid=1861732375>.

A necessary conclusion to that decision, was that citations to dictionary definitions in an appeal brief cannot form the basis for holding an appeal brief to be non compliant. See the discussion of this case in "Will the Board of Patent Appeals and Interferences Rely Upon Dictionary Definitions Newly Cited in Appeal Briefs? Answer: It Depends", By Richard Neifeld, Neifeld IP Law, PC, available at http://www.neifeld.com/pubs/2009_appealsdictionary.pdf. Thus, it is USPTO precedent that citations to dictionary definitions in an appeal brief cannot form the basis for holding an appeal brief to be non compliant.

Moreover, USPTO precedent, paper date 08-05-2009, Decision on Petition, Reexamination 90/006,707, patent 5,505,464, docketed appeal No. 2009-007210 (Decision by the Chief Administrative Patent Judge, Michael Fleming), establishes that, the Board is entitled to consider dictionary definitions, regardless whether they were cited by the examiner, the appellant, or by no party:

4. Patent Owner cites and quotes from *Phillips v. AWH Corp.*, 415 F.3d 1303, 1324 (Fed. Cir. 2005) as follows:

[A] judge who encounters a claim term while reading a patent might consult a general purpose or specialized dictionary to begin to understand the meaning of the term, before reviewing the remainder of the patent to determine how the patentee has used the term. Petition at p. 5.

A panel of administrative patent judges at the Board may consider dictionary definitions to assist it in determining the scope of claims under review. The panel may use a dictionary definition found *de novo* by the panel. This approach was sanctioned by the Federal Circuit; in *Phillips*, *supra*.

With that precedent in mind, the appellant cites to dictionary definitions herein below for meaning of words in the claims. The Board is as noted above, free to consider, *de novo*, these dictionary definitions.

Claim 32's "embedding a watermark into said software" refers to a function acting on both digital data representing watermark and digital data representing software.

Our specification discloses an invention requiring both watermark and software data represented in digital form. We note in our *field of the invention* section of our specification that "[0003] With the advent of computer networks and digital multimedia, protection of intellectual property has become a prime concern for creators and publishers of **digitized copies** of copyrightable works, such as musical recordings, movies, video games, and computer software. One method of protecting copyrights in the digital domain is to use "**digital watermarks.**" ... [0006] **Digital watermarks** can be used to mark each individual copy of a **digitized work** with information identifying the title, copyright holder, and even the licensed owner of a particular copy. ... [0013] The present invention includes an application of the technology of "**digital watermarks.**" As described in previous disclosures,".

Similarly, our *background of the invention* section, repeatedly describes the use of "digital watermarks" in securing content ([0016], [0017]) and drawbacks of pre-existing use of "digital watermarks" ([0019], [0022], [0023], [0026], [0027]).

Subsequently, our *summary of the invention* section, explains that the invention is **directed to use of digital information.**

SUMMARY OF THE INVENTION

[0030] The disadvantages of the art are alleviated to a great extent by a method for combining transfer functions with predetermined key creation. *In one embodiment, digital information, including a digital sample and format information, is protected by identifying and encoding a portion of the format information. Encoded digital information, including the digital sample and the encoded format information, is generated to protect the original digital information.*

[0031] *In another embodiment, a digital signal, including digital samples in a file format having an inherent granularity, is protected by creating a predetermined key. The predetermined key is comprised of a transfer function-based mask set to manipulate data at the inherent granularity of the file format of the underlying digitized samples.*

[0032] It is thus a goal of the present invention, to provide a level of security for executable code on similar grounds as that which can be provided for **digitized samples**. Furthermore, the present invention differs from the prior art in

that it does not attempt to stop copying, but rather, determines responsibility for a copy by ensuring that licensing information must be preserved in descendant copies from an original. Without the correct license information, the copy cannot function.

Subsequently, our *detailed description* section explains that our invention is limited to digital data, referring to strictly digital concept of keys, digital watermarking, and stega-ciphers, CDs, digital signatures, one way hash functions. [0036] to [0044]. Nothing in the embodiments following thereafter would be consistent with a non digital data. All of the embodiments require software represented in digital data and digital watermark data for watermarking the software.

Therefore, **Claim 32's "embedding a watermark into said software"** is limited to embedding digital watermark data into a digital data representing the software code.

Claim 32's "computer" means "a machine that stores programs and information in electronic form and can be used for a variety of processes." See for example

<http://www.onelook.com/?w=computer&ls=a>. That definition is consistent with claim 32's recitations of a processor, memory, and functionality of being capable of embedding a watermark in software.

Moreover, in the detailed description, the specification states that: “[0056] ... When code and data resources are *compiled and assembled* into a precursor of an executable program the next step is to *use a utility application for final assembly* of the executable application.”

Reference to use of a utility application requires use of a computer. This is because “utility

application” in context is and was at the relevant time understood to refer to a software utility application running on a digital computer system. The reference to "*compiled and assembled*" in context is and was at the relevant time understood to refer to use of a software utility application running on a digital computer system that performed the operations of compiling and assembling. The more relevant point is that claim 32's "computer" means "a machine that stores programs and information in *electronic form* which supports the digital processing inherent in claim 32 in view of the disclosure.

Claim 32's “modifying software” defines modifying a program used by computers for doing a particular job. However, "modifying" should be construed to cover additions of security features as opposed to changing user desired functionality.

Claim 32 recites “A computer-based method for modifying software, comprising:” For the reasons noted below, claim 32's “modifying software” defines modifying computer software.

Software generally means "programs used by computers for doing particular jobs." See for example: <http://www.macmillandictionary.com/dictionary/american/software>. In the computer science field, a definition of software is "written programs or procedures or rules and associated documentation pertaining to the operation of a computer system and that are stored in read/write memory." See for example:

<http://wordnetweb.princeton.edu/perl/webwn?s=software&sub=Search+WordNet&o2=&o0=1&o8=1&o1=1&o7=&o5=&o9=&o6=&o3=&o4=&h=>. This more technical definition is consistent with software defining "programs used by computers for doing particular jobs." Software defining "programs used by computers for doing particular jobs" is consistent with claim 32's

preamble defining a "computer-based" method, and claim 32's body defining "wherein said software provides a specified functionality." Software defining "programs used by computers for doing particular jobs" is consistent with the prosecution history. Therefore, claim 32's "modifying software" defines modifying a program used by computers for doing a particular job.

References in the *field of the invention* section of our specification also confirm that claim 32's "modifying software" defines modifying a program used by computers for doing a particular job. In the field of the invention section, the specification states: "[0003] With the advent of computer networks and digital multimedia, protection of intellectual property has become a prime concern for creators and publishers of digitized copies of copyrightable works, such as musical recordings, movies, video games, and **computer software**.... [0004] ... Copy protection was generally abandoned by the software industry, since pirates were generally just as clever as the **software engineers** and figured out ways to **modify the software** and deactivate the protection." The antecedent in paragraph 4 for "**modifying the software**" is the paragraph 3 recitation "**computer software**." This shows that "modifying software" means modifying **computer software**. This in turn is further support for the conclusion that claim 32 is directed to a method acting on digital data.

The statement in the specification that "pirates were generally just as clever as the software engineers and figured out ways to **modify the software** and deactivate the protection.", [0004], refer to a modification that removes "the protection" and not a modification in the specified functionality, such as for example word processing capability, provided by the software, to a user of the software. This passage clarifies that **modifying** software does not require changing the specified functionality enabling the software to do particular jobs, such as

word processing. It may instead refer to modifying software by adding a watermark and/or adding functional protection.

Claim 32's "specified functionality" defines the capability of the software doing a particular job.

As noted above, the word "software" means programs used by computers for doing a particular job. Software when installed on computer is functional, capable of doing a particular job. It is a "specified functionality" of a software product that provides such capability to the software product. Claim 32's "specified functionality" defines that capability. Our specification refers to this concept, for example, as: **"functions sought out by the user** in the form of software" in [0033]; and "When a user purchases or acquires a computer program, she seeks a computer program **that "functions" in a desired manner**. Simply, computer software is overwhelmingly purchased for its **underlying functionality**." in [0053]. The word "specified" means "clearly and explicitly stated. See for example <http://www.onelook.com/?w=specified&ls=a>. The word "functionality" means "the range of things that a computer or other electronic system can" See for example <http://www.onelook.com/?w=functionality&ls=a>. Therefore, "specified functionality" means a clearly and explicitly stated range of things a computer ... system can do. The word "provides" means "supply means". Therefore claim 32 recites "wherein said software provides a specified functionality" mean that said software supplies a means to a computer of clearly and explicitly stated range of things the computer can do. That is consistent with of the same scope as our specifications's description of software providing"functions sought out by the user " and

"underlying functionality". Thus, claim 32's "specified functionality" defines the capability of the software doing a particular job.

Claim 32's "embedding a watermark into said software" means changing the digital data defining the software to include the watermark; not changing the claimed "specified functionality" of the software.

Claim 32's "embedding a watermark into said software" means "embedding a watermark into software "that provides .. [said] specified functionality." In the context of digital data, a watermark means information embedded into a digital signal. See for example http://en.wikipedia.org/wiki/Digital_watermarking ("Digital watermarking is the process of embedding information into a digital signal..."). Information in digital data means at least one bit, or a pattern of bits, inserted into a digital signal. See for example http://www.webopedia.com/TERM/D/digital_watermark.html ("Also referred to as simply watermarking, a pattern of bits inserted into a digital image, audio or video file"). Our specification discloses that the watermark may include information defining the license required to activate the software. Our specification does not specify that the watermarked software, once activated, have a different functionality than the unwatermarked software. Cf. [0056] ("The purpose of this scheme is to make a particular licensed copy of *an application* distinguishable from any other." Here, *application* corresponds to the claimed "*specified functionality*.")

One form of embedding is superposing. The word "superpose" means to place upon one another. See, for example: <http://www.onelook.com/?w=superpose&ls=a>. Mathematically, that means to define a function of two variables such that the function at a location is a function of

the value of the two variables at that location. Superposition is how Houser defines watermarking. Houser describe's watermarking, clarifying that the *chop* and *watermark data* are superimposed: "The display controller may thus control the display device to *display the electronic chop **superimposed** on the watermark graphic* if the verification processor verifies the signed electronic document", column 4 lines 57-60; "The indication controller may then control the display to display the *video chop graphic **superimposed** over the video watermark* in the displayed electronic document", column 6, lines 20-24; "In any event, the *video chop* may be **superimposed** over the *video watermark* and the *printed chop* may be **printed over** the *printed watermark* to provide a detection capability and thereby deter attempts at the falsifying a 'signature'.", column 8 lines 28-33; and "Display of the electronic watermark generates a difficult-to-forge video watermark. For example, the *video chop* may be **superimposed** on the *video watermark* when displayed on a document reviewer's display to indicate the verification result.", column 17, lines 5-9.

Our specification uses the word "embed" to describe the watermarking process as one that changes the original content. "To achieve these goals, digital watermark systems insert ownership information in a way that causes little or no noticeable effects, or "artifacts," in the underlying content signal. For example, if a digital watermark is inserted into a digital version of a song, it is important that a listener not be bothered by the slight changes introduced by the watermark." in [0017];

Claim 32 next recites "embedding a **watermark** into said software, using said computer,". During prosecution, the applicant noted that "**A watermark in this art refers to information embedded into a digital signal in a way that is difficult to remove.**" See the

2-28-2011 response to the 11-26-2010 rejection under 102 based upon Houser. This interpretation of the meaning of watermark is consistent with how Houser defines a watermark, as noted above. This interpretation of claim 32's "watermark" is consistent with and supported by the description in the field of the invention, of the goal of copyright protection. The field of the invention section contains the following statements indicating that watermark as used in this application means information that is difficult to remove from the digital signal defining the software: "[0003]... One method of protecting copyrights in the digital domain is to use '**digital watermarks**' ... [0006] Digital watermarks can be used to mark each individual copy of a digitized work with information identifying the title, copyright holder, and even the licensed owner of a particular copy. When marked with licensing and ownership information, responsibility is created for individual copies where before there was none. Computer application programs **can be watermarked by watermarking digital content resources used in conjunction with images or audio data** ... [0010] In this way, attempts to capture memory to determine underlying functionality or provide a "patch" to facilitate unauthorized use of the "application," or computer program, without destroying the functionality and thus usefulness of a copyrightable computer program **can be made difficult or impossible.** ... "

This interpretation of claim 32's "watermark" is consistent with and supported by the description in the background of the invention section. There, our application states "[0016] ... It is therefore desirable to embed copyright, ownership or purchaser information, or some combination of these and related data, into the content **in a way that will damage the content if the watermark is removed without authorization.**"

And also that "[0017] To achieve these goals, digital watermark systems insert

ownership information in a way that causes little or no noticeable effects, or 'artifacts,' in the underlying content signal. For example, if a digital watermark is inserted into a digital version of a song, it is important that a listener not be bothered by the slight changes introduced by the watermark. It is also important for the watermark technique to maximize the encoding level and "location sensitivity" in the signal **to force damage to the content signal when removal is attempted.** Digital watermarks address many of these concerns, and research in the field has provided extremely robust and secure implementations.” This directly supports the construction of claim 32's “watermark” as “difficult to remove” because damage to the content would not be removal, but modification of the original content.

And also that "[0020] Other methods embed ownership information that is plainly visible ... The system described in Braudaway protects a digitized image by encoding a **visible watermark** to deter piracy. Such an implementation creates an immediate weakness in securing the embedded information because the watermark is plainly visible. Thus, no search for the embedded signal is necessary and **the watermark can be more easily removed or altered.**" Our specification identifies Braudaway as USP 5530739 [sic]. However, Braudaway is actually USP 5530759. Reference to Braudaway in fact supports our interpretation. Our specification does not say that Braudaway discloses that it is easy to remove Braudaway's watermark. Only that Braudaway's visible watermark can be "**more easily removed or altered**" because it is visible. Review of Braudaway's disclosure indicates that it is directed to an improvement in digital watermarking to improve "chromaticity", that is, quality of color of a watermarked image. Braudaway's watermarking algorithm is in fact quite complicated, including noise addition to adjust graininess, (block 208, 201, noise components RN) and therefore he does not disclose a

mechanism to remove his generically disclosed watermark. In fact, Brouday comments in the penultimate paragraph that, if the random noise is replaced by "reproducible (ciphered) random sequence, or a noise sequence created by a ciphered key", then a system for removing the watermark using a cipher key could be designed. Thus, while Brouday discloses a visible watermark, in no way does the discussion in our specification of Brouday imply that a digital watermark means something that is not difficult to remove without damaging the content into which it is embedded.

This interpretation of claim 32's "watermark" is consistent with and supported by the description in the detailed description section of an embodiment. See the embodiment described in paragraphs [0053] to [0062]. This embodiment discloses use of the stega-cipher process to hide a watermark in the content, as noted for example in paragraph [0055]. "[0055] Given that there are one or more of these essential resources, what is needed to realize the present invention is the presence of certain data resources of a type which are amenable to the "stega-cipher" process described in the "Steganographic Method and Device" patent U.S. Pat. No. 5,613,004." USP 5,613,004 is incorporated by reference into this application. See [0011]. A stega-cipher generated watermark is difficult or impossible to remove without the corresponding key. This is noted in the summary of the invention section, first, fourth, and fifth paragraphs, in 5,613,004, which reads:

**The invention disclosed herein combines two techniques,
steganography – obscuring information that is otherwise in plain sight, and
cryptography -- scrambling information that must be sent over unsecured**

means, in a manner such that only the intended recipient may successfully unscramble it. The net effect of this system is to specifically watermark a piece of content so that if it is copied, it is possible to determine who owned the original from which the copies were made, and hence determine responsibility for the copies. It is also a feature of the system to uniquely identify the content to which it is applied.

The invention improves upon the prior art by providing a manner for protecting copyright in the digital domain, which neither steganography or cryptography does. It improves specifically on steganography by making use of special keys which dictate exactly where within a larger chunk of content a message is to be hidden, and makes the task of extracting such a message without the proper key the equivalent of looking for a needle in a haystack.

The information encoded by the Stega-Cipher process serves as a watermark which identifies individual copies of content legally licensed to specific parties. *It is integral with the content. It cannot be removed by omission in a transmission.* It does not add any overhead to signal transmission or storage. It does allow the content to be stored to and used with traditional offline analog and digital media, without modification or significant signal degradation. These aspects of the stega-cipher all represent improvements to the art. ***That is, it forces would-be pirates to damage the content in order to guarantee the disabling of the watermark.***

The pseudo code appendix starting in column 17 in 5,613,004, incorporated by reference into this application, provides an express teaching how to generate a stega-cipher.

As noted at the end of paragraph [0062] in our application, “The present invention has the significant advantage that you must have the watermark to be able to use the code it contains. If you erase the watermark you have lost a key piece of the functionality of the application, or even the means to access the data which bear the watermark.” Therefore, claim 32’s “watermark” in the recitation “embedding a watermark into said software” means at least something that is difficult to remove. In the context of the software application disclosed in an embodiment in our application, damage is fatal to providing the functionality of the software application, because it precludes operation of essential resources in the software code. Cf. paragraphs [0054] and [0055]. The linking of functionality to the license code embedded in the watermark is *not* defined by claim 32. However, it is defined by other claims. In any case, the description in the specification of that feature is obviously consistent with the claimed “watermark” defining information difficult to remove with damaging the content into which it is embedded.

Claim 32 next recites “said watermark encoding at least one first license code,” which defines encoding in the software a license code *for that instance of the software*.

The invention disclosed in our application generically speaking is the watermarking of each instance of the software with a key corresponding to a license code for the software. In the 7-1-2011 response, the applicant stated that “Regarding claim 32, note that the specification indicates that a particular license code is what is required to be input into a system running a

particular software object encoded with a key corresponding to that license code, in order to allow the system to use the functionality of the software. See [0056]-[0057]." However, the specification contains more references defining a license code to mean a valid code that must be entered to make a software product to enable the product to provide its specified function.

In the field of the invention, the specification provides the following references defining a license code to mean a valid code that must be entered to make a software product function:

[0005] *Other methods for protection of computer software include* the requirement of entering certain numbers or facts that may be included in a packaged software's manual, when prompted at start-up. ... requiring a user to contact the software vendor and to receive "keys" for unlocking software after registration ... network-based searches of a user's hard drive and comparisons between what is registered to that user and what is actually installed on the user's general computing device. ... "kerning" or actual distance in pixels, in the rendering of text documents, rather than a varied number of ASCII characters. ... All of these methods *require outside determination and verification of the validity of the software license.*

[0006] **Digital watermarks can be used to mark each individual copy** of a digitized work with information identifying the title, copyright holder, and even the licensed owner of a particular copy. ...

[0008] ...Further, *if the key is linked to a license code* by means of a mathematical function, a *mechanism for identifying the licensed owner of an*

application is created.

[0013] ...Computer code, or machine language instructions, which are not digitized and have zero tolerance for error, must be protected by derivative or alternative methods, such as those disclosed in this invention, which focuses on watermarking with "keys" **derived from license codes or other ownership identification information**, and using the watermarks encoded with such keys to hide an essential subset of the application code resources.

In the summary of the invention section, the specification provides the following references defining a license code to mean a valid code that must be entered to make a software product function:

[0032] It is thus a goal of the present invention, to provide a level of security for executable code on similar grounds as that which can be provided for digitized samples. Furthermore, the present invention differs from the prior art in that *it does not attempt to stop copying, but rather, determines responsibility for a copy by ensuring that licensing information must be preserved in descendant copies from an original.* **Without the correct license information, the copy cannot function.**

[0033] An improvement over the art is disclosed in the present invention, in that the software itself is a set of commands, compiled by software engineer, which can be configured in such a manner as **to tie underlying functionality to**

the license or authorization of the copy in possession by the user. Without such verification, the functions sought out by the user in the form of software cease to properly work. Attempts to tamper or "patch" substitute code resources can be made highly difficult by randomizing the location of said resources in memory on an intermittent basis to resist most attacks at disabling the system.

In the detailed description section, the specification provides the following references defining a license code to mean a valid code that must be entered to make a software product function. Paragraph [0056] states bluntly that "**The purpose of this scheme is to make a particular licensed copy of an application distinguishable from any other.**" Paragraphs [0057] to [0061] disclose that the "license code" means information that must be entered into the modified software application resulting from the method of claim 32, so that the modified software application provides the claimed "specified functionality". See: "[0057] The assembly utility can be supplied with a key **generated from a license code** generated for the license in question. Alternatively, the key, possibly random, can be stored as a data resource and encrypted with a derivative of the license code. ... **The application can then operate as follows:** [0058] 1) when it is run for the first time, after installation, **it asks the user for** personalization information, which includes **the license code**. This can include a particular computer configuration; [0059] 2) it stores this information in a personalization data resource; [0060] 3) **Once it has the license code, it can then generate the proper decoding key to access the essential code resources.** [0061] Note that the application can be copied in an uninhibited manner, **but must contain the license code issued to the licensed owner**, to access its essential

code resources."

Thus, our specification, consistent with common understanding in the art, defines a license code for a software application to be a code required to be entered into the software application to activate the application, to enable the application to provide its specified functionality. **In view of the foregoing, claim 32's "said watermark encoding at least one first license code," means a watermark encoding a "license code" valid (meaning capable of activating) the claimed "first license code encoded watermarked software."** Assuming arguendo, the Board disagrees, then **claim 32's "said watermark encoding at least one first license code,"** still certainly limits the "first license code" to a code associated with the claimed software. That is, even if claim 32 does not require that code to be the one necessary to activate the software, it still requires that code to be one that is a license code for some instance of that software product. That is, the claim recitation "at least one first license code" must be given meaning. Words are not read out of claims. Its broadest possible meaning giving it effect is a license code for some 'copy' of the software, if not the one into which it is embedded. Otherwise, the recitation "said watermark encoding at least one first license code, thereby resulting in a first license code encoded watermarked software" would have no meaning. Cf. Bicon, Inc. v. Straumann Co., 441 F.3d 945, 950 (Fed. Cir. 2006)("Claims must be 'interpreted with an eye toward giving effect to all terms in the claim.'")

WHY THE 103 REJECTION OF CLAIM 32 IS IMPROPER.

CLAIM 32

Claim 32 recites:

32. (Previously Presented) A computer-based method for modifying software, comprising:

receiving, in a computer having a processor and memory, software, wherein said software provides a specified functionality;

embedding a watermark into said software, using said computer, said **watermark encoding at least one first license code**, thereby resulting in a **first license code encoded watermarked software**.

HOLMES

The examiner agreed that Holmes does not disclose a watermark. Second NFOA, 4-1-2011, page 5, last paragraph; second FOA, 9-24-2011, page 4, last paragraph, "Holmes does not teach embedding the data as a watermark."

The examiner also agreed that Holmes does not disclose claim 32's "encoding at least one first license code". Second NFOA, 4-1-2011, page 5, lines 22-23; second FOA, 9-24-2011, page 4, second to last paragraph, "Holmes teaches ... a unique identifying data (which could serve as a license for the software) associated with a user or the system or the software." Unique identifying data is not a license for the software. Whether it *could serve* as a license is not the point, and not relevant. Holmes does not disclose or suggest that it could serve as a license for the software. In fact, the way Holmes' invention changes the data to track who has accessed the file would be inconsistent with the identifying data serving as a license for the data file into which it is embedded.

In summary, all Holmes discloses is modifying a file by adding tracking data to the file.

It does not disclose claim 32's "embedding a watermark into said software" because its tracking data file is not a watermark. It does not disclose claim 32's an embedded watermark, and it does not disclose an encoded "license code," because its tracking data file has no disclosed licensing function.

What Holmes actually teaches is clear from its abstract, which states that: "A master copy of a software file has within it a predetermined block of data. When a copy of the file is made that block of data within the copied file is located and overwritten with data identifying the copied file. When an unauthorized copy is found, the data identifying the copy can be read and the source of the unauthorized copy may be traced." Holmes clearly distinguishes data from code, and discloses, only, inserting data identifying the copied file into a "predetermined block of data". Holmes does not disclose only changing data in a data block of a "file". This data "block" means a sequential set of values. Cf. description of Fig. 1, "block 8 contains a predetermined sequence of code, in this example represented by `AAAAAA`."

Holmes teaches embedding in a data file, or a software file, a unique identifying data that is associated with a user or the system or the software. (Holmes states " However, in preferred embodiments of the invention said data identifying said copy file includes one or more items of data identifying the time at which said copy file was made, the authorized user of said copy file, said first data processing system and/or said second data processing system.")

The applicant notes that Holmes contain no mention of license, activation, or the like, relating to license codes for software. Holmes does not suggest that its embedded identifying data "could serve as a license for the software." Moreover, Holmes teaches away from that concept by going out of its way to point out that presence or absence of the predetermined block

of data in a software file does not affect its functionality:

Another advantage of the system is that a software file may be produced by a software vendor to include the predetermined block of data, but use of that file will not require use of the technique of the invention. Accordingly, the same software file can be used in systems which do or do not implement the invention. The particular combination of elements comprising the invention provides a security technique which is surprisingly simple to implement and effective in use. ... Furthermore, producers of software files can include within them the necessary predetermined block of data which can be used to mark files distributed within the network, and yet, if desired, the same version of the software file can be copied and distributed by conventional techniques without using the invention.

The way Holmes accomplishes its advantages is by predetermining the location of the data block in its file, and then only overwriting data in that location in the file with data unique to each copy, as stated in the description of its Figure 1, noting the reference to "in the same position":

FIG. 1 shows a master file 6 stored within a first data processing system 2. The master file 6 has embedded somewhere within it a predetermined block of data 8. The block 8 does not play any part in the function of the software of the master file itself; rather its function is to provide a locatable space within the

master file in which data identifying a copied file may be written. The block 8 contains a predetermined sequence of code, in this example represented by `AAAAAA`.

A copy of the master file 6 is then transmitted to a second data processing system 4 which stores it as copied file 10. The block 8 is copied with the rest of the master file 6 and so the copied file 10 also contains a block 8 in the same position as the block 8 within the master file 6.

Thus, all Holmes teaches is encoding a single data block at a predetermined location in any file, with data unique to each copy. Whether the rest of the file is software or data is irrelevant, because this single predetermined data block location is functionally disconnected from the surrounding locations in the same file, whether they are data or software.

WE DISAGREE WITH THE EXAMINER'S CONFLICTING, AFTER FINAL, ASSERTION THAT HOLMES DISCLOSES ENCODING A LICENSE CODE

Our 7-21-2011 response, quoted above, traversing the 103 rejection, concluded that "Thus, all Holmes teaches is encoding a data block at a predetermined location in any file, with data unique to each copy. Whether the rest of the file is software or data is irrelevant, because this predetermined location is functionally disconnected from the surrounding locations in the same file, whether they are data or software." That conclusion was in response to the 4-1-2011 OA. In the 4-1-2011 OA, the examiner admitted that "Holmes does not teach embedding the data as a watermark."

In the 9-20-2011 second FOA, the examiner supplemented the basis for rejection in the section titled "Response to Arguments", by factually asserting that Holmes teaches that "*The block of embedded code serves as a license code to provide identifying data for the software file.*" 9-20-2011 second FOA, page 3, lines 4-5.

The examiner stated at second NFOA, 4-1-2011, page 5, lines 22-23; and second FOA, 9-24-2011, page 4, second to last paragraph, that "Holmes teaches ... a unique identifying data (which could serve as a license for the software) associated with a user or the system or the software."

In response, first the appellant notes that this assertion is contradictory to the examiner's admission that Holmes does not disclose the block of embedded data serves as a license code. "*could serve as*", in contrast to actually "*serves as*", are entirely different assertions. My mother *could serve as* the president. However, she does not serve as the president. Holmes does not disclose "*The block of embedded code serves as a license code ...*".

Second, Holmes does not disclose "The block of embedded code serves as a license code." As noted herein above, Holmes contain no mention of license, activation, or the like, relating to license codes for software. Instead, Holmes merely discloses that the "predetermined block of data 8" is "a locatable space within the master file in which data identifying a copied file may be written." *Description of the preferred embodiment* section, first paragraph.

Third, Holmes' express objects contradict the notion that Holmes discloses the data block 8 storing a license code. Holmes states that its objects are for "easily identifying unauthorized copies of data files" and "identifying the source of unauthorized copies of data files." Holmes, *objects of the invention* section. Identifying and determining source of copies of files is not

licensing.

Moreover, the data identified by Holmes in this block is audit data generated from time to time, in response to access of the file regardless of master file location or control of the master file. Such data would be inappropriate as license data; data generated by the original creator relating to a legal right or functional capability, to access and use the corresponding master file.

In summary, Holmes discloses a method for tracking users/access. Holmes does not disclose either embedding a watermark into software or such a watermark encoding a license code.

HOUSER

Houser discloses "Electronic document verification system and method." Title. Similarly, Houser's field of the invention section specifies "The invention generally relates to a system and method for indicating authenticity in connection with computer operations. ... and for using the results of the verification processing to control the display of video or printed indicia to thereby indicate the verification results to a user." Column 1 lines 7-21. Houser explains in the Abstract that "The integrity or the signator of an electronic document can be verified by embedding a security object, for example, supported by an object linking and embedding (OLE) capability, in the electronic document at a location selected by the signator." Houser further explains in the Abstract that "The embedded security object includes security information and an identifier for invoking the processing of the security information. The security information may [be] ... the signator's electronic chop, which may be the signator's digitized signature or other graphic image." Houser further explains in the Abstract that "When

the electronic document is later displayed ... If the signator and the document integrity are confirmed, the electronic chop is displayed in the document. If, however, the signator or document integrity are not verified, the electronic chop is not displayed."

Houser's title, field of the invention section, and Abstract therefore disclose that the security object is embedded in an electronic document "at a location selected by the signator" and that the chop is a "graphic image" such as the signator's digitized hand written signature. The remainder of Houser explains that process in more detail. However, the relevant points are that the security object is at a specified location, a single location, selected by the signator.

One additional relevant point is that House discloses watermarking the electronic chop, and does not disclose watermarking the remainder of the electronic document. As a result, Houser's watermark is localized at the specified location, the single location selected by the signator, in the document.

Houser further explains that "By interaction of the signature insertion module 240, information can be embedded into the electronic document 510 at a location selected by the user." That statement is in reference to Fig. 5, which shows insertion of OLE objects 520, 530, each at a distinct geographic location in a the display of text document 510. Houser consistently indicates that each OLE object in the file is at a distinct location in the file and displays at a distinct location on a monitor or printed document. Houser defines a digitized signature at column 2 lines 1-14 to mean a hand written ink signature that is captures in electronic form using a digitizer. That is, the digitized signature is something that can be "pasted into an electronic document". Houser's express definition of a digitized signature reads "digitized signature" refers to an electronic graphic representation of a signature obtained using a digitizer, for example, and

to the display or print out of such electronic graphic representation."

Houser specifically distinguishes a "digitized signature" from an "electronic signature" at column 2 lines 40-61. Houser's express definition of an "electronic signature" reads "An electronic signature, as used herein and commonly throughout the industry, refers to a block of electronic information, e.g., a bit sequence, which strongly characterizes the state of a document at a particular time, and is typically generated using a secure hashing algorithm."

Houser clarifies that, in contrast with an "electronic signature" the utility of its "digitized signature" is for visual inspection by a person, "an electronic graphic representation of an individual's handwritten signature which likewise may be used to identify the signator, but by visual inspection." Column 2 lines 57-62.

Houser identifies the problem he addresses, noting that both (1) the document configuration management systems and (2) electronic signature systems, while secure, are too complex for the "average computer user". Houser identifies that a technique which is "user-friendly" and provides "a sufficient degree of security" is the goal of his invention. Column 3 lines 33-45.

Houser explains that his process provides generating the OLE object so that it contains (1) data characterizing the electronic document and (2) the electronic chop (such as the digitized signature") of the person who added the OLE object to the electronic document. Column 7 lines 29-59.

Houser explains that a document reviewer in receipt of an electronic document can run a verification process that will only display the electronic chop (such as digitized signature) of the document creator if the verification process confirms the document was not altered since the

OLE object was added ("The document digest in the embedded security object may be used to verify whether the document was altered after the security object was embedded."). Column 7 line 66 to column 8 line 19.

Thus, Houser accomplishes his goal of accommodating non sophisticated computer users, by using the display of the electronic chop, or lack of display of the electronic chop, to indicate whether the electronic document has been altered since the OLE object was added, and to display the identity (electronic chop) of the person who added the OLE object.

Houser then explains that the document reviewer of the electronic document can further modify the electronic document and embed a second OLE objection, identifying the modified document and the document reviewer's identity. See Fig. 1, showing process flow from 160, to 170, to 130, and column 8 lines 33-39.

Houser column 7 lines 15-19 indicate that the electronic document is one created by a "conventional application" giving the examples of "Word", ... "Excel" as such applications. These applications require text data be displayed on locations on a monitor. These applications store text data. Watermarking text data is not a concept disclosed or suggested by Houser. Houser does not disclose or enable manipulating watermarked text data. Houser's electronic documents being further manipulated by for example Word or Excel, as taught by Houser, are inconsistent with a watermark of the text data of those documents. What the facts and conclusion in this paragraph lead to is the conclusion that Houser's discussion of watermarking refers only to watermarking of the display of the OLE object data when that OLE object is displayed with the portion of the electronic document generated by the application program, such as Word or Excel. This conclusion is consistent with and supported by Houser's disclosure

relating to watermarking.

Just prior to explaining how the document reviewer can function to verify and add an OLE object to form a modification of the electronic document, Houser mentions creation and use of a viewable (displayable) watermark as an additional security measure. In this passage, Houser discloses that "In any event, the video chop may be superimposed over the video watermark and the printed chop may be printed over the printed watermark to provide a detection capability and thereby deter attempts at the falsifying a 'signature'." Column 8 lines 20-33. What his "In any event" sentence means is that, whether printed to paper or displayed on screen, the chop and watermark occupy the same space. They are "superimposed", which means placed on one another, and in the context of video data, it means that points in space display the output of a function of the values for the two variables, chop and watermark, at that location in the display. This discloses the watermark appearing only in the region of space in which the OLE object's data is displayed. As Houser notes elsewhere, the OLE object data displays at predetermined locations within the display of the electronic document. See Figs. 5, elements 520, 530, and their discussion at column 12 lines 20-29. The following paragraph at column 12 lines 31-40 clarifies by that Fig.5 represents display of the electronic document, not a data structure of the electronic document.

The last four paragraphs of Houser's summary of the invention section also refer to the watermarking. Column 5 lines 50 to column 6 line 41. These paragraphs consistently refer to display of a watermark (1) as a graphic displayed independent of the electronic document and (2) when in connection with display of the electronic document, only when superimposed with the electronic chop, the region of the electronic document displaying the OLE object. (Fourth to last

paragraph, "Accordingly, the display controller may therefore control the display device to display the electronic chop superimposed on the watermark graphic.", and in the last paragraph "The indication controller controls the printer to print the printed chop graphic superimposed over the printed watermark in the printed electronic document.")

Houser Fig. 7E shows an example of the "user's electronic chop 750", which appears to be the digitized version of the user's hand written entries in a region titled "APPROVALS" in a display of an electronic document during creation of that document.

Houser column 17 lines 5-13 discloses display of a watermark. That paragraphs states:

Display of the electronic watermark generates a difficult-to-forge video watermark. For example, the video chop may be superimposed on the video watermark when displayed on a document reviewer's display to indicate the verification result. The video watermark provides security against programs written to mimic the electronic document security application. More generally, the video watermark may be used to authenticate any display that may be imitated by a "Trojan Horse" program. The appellant understands the foregoing quotation to disclose watermarking only of the video chop region of the display of the electronic document. That understanding is consistent with the goal of Houser of securing the OLE object, and not securing the remainder of the data defining the electronic document, which is the data generated by the application program (such as Word or Excel). Again, this understanding is also consistent with the final disclosures in Houser regarding watermarking in connection with the time dependent watermarking security measures and printed document security measures, disclose in connection with Figs. 10 and 11. There, Houser states that: The video watermark may serve to inhibit forgery as follows. The document reviewer may compare the displayed video chop and video

watermark with a displayed video chop and video watermark processed and displayed using another computer. For example, the document reviewer may telephone another party and request the time of day that the clock face video watermark displays. If the displayed times do not match, the document reviewer can detect a forgery. Thus, the document viewer can guard against so-called "trojan horse" programs that attempt to mimic the display features of the electronic document security application or another application selected by the user. If the watermark is generated using information particular to the signator, then the watermark may be confirmed against any electronic document signed by the signator. [Column 18 lines 9-23.]The foregoing quotation indicates that the video chop and video watermark are superimposed.

And Houser states with respect to printing that "According to one preferred embodiment, the printed chop may be superimposed on a printed watermark generated by the watermark generator 840 to thereby make it more difficult to forge a paper copy of the document." Column 18 lines 63-66.

Finally, respecting an embodiment using keys, Houser notes that "The video chop is superimposed over the video watermark if verification processing is successful. The video watermark is not displayed if verification is unsuccessful. Rather, a warning message is generated." Column 19 lines 33-37.

In summary, Houser discloses that his watermark is displayed superimposed on the display of the OLE object's electronic chop (digitized signature or like identifier of a person modifying a document), which is in a specified by the user, single location, in the display of the electronic document, not in other regions of a displayed electronic document.

Houser's electronic document is data, it is the work product resulting from using some

application program, for example Word or Excel. It is not a software program.

HOLMES AND HOUSER

Both Holmes and Houser place data in small regions of a larger file. Holmes places audit/tracking data, easily identifiable and interpretable (lacking encryption) that indicates identity of entities that may have changed non tracking information portion of the Holmes' file. Houser places, in or associated with, a document, different OLE objects, each identifying a document modifier and state of the document for the purpose of verifying the document as modified by the previous modifier.

Neither discloses a watermark encoding a licence code embedded software. Claim 32 defines the step of "embedding a watermark into said software, using said computer, said watermark encoding at least one first license code, thereby resulting in a first license code encoded watermarked software."

A combination of Holmes and Houser would not result in a modified software file with an embedded "watermark encoding at least one first license code." Therefore, any such combination would not be what claim 32 defines. Houser does not disclose a watermark encoding at least one first license code. Holmes does not disclose a watermark. Accordingly, claim 32 is not an obvious variation of either Holmes or Houser in view of one another.

Moreover, Holmes and Houser are not compatible, and the modification of Holmes in view of Houser proposed by the examiner is improper. The examiner states that the modification is as follows:

[1] Therefore, one of ordinary skill in the art would have been motivated to modify Holmes' teaching by embedding the identification data as a watermark wherein the watermark cannot be forged and is also difficult to remove for the purpose of protecting the watermarked software and preventing unauthorized users from tampering with the identification data. [9-20-2911 second FOA, page 5, lines 1-5.]

This conclusion is based upon the examiner's assertion that:

[2] Houser teaches embedding information as a digital watermark into a media. [9-20-2011 second FOA, page 4, penultimate and ultimate lines.]

The following errors existing in these statements and conclusions [1] and [2].

First, neither Holmes nor Houser have a purpose of "protecting ... software .. from tampering". Holmes provides an audit trail, in effect, to identify unauthorized copies of a file. Houser provides a security object which has data identifying the state of the file into which the security object has been embedded, so that any modification of the file can be detected. Houser discloses no protection against tampering, only user visual verification.

Second, proposed modification would not result in a "watermark ... difficult to remove." This is because Houser's OLE object, watermarked or not, would be stored in Holmes' defined single location. Therefore, it would be easy to remove. Its only role is verification, not protection. While it may be difficult to remove Houser's watermark from his electronic chop, it

would not be difficult to remove the OLE object from Houser's document, or the Holmes file modified to include Houser's OLE object. Removing the OLE object would remove both Houser's chop and watermark thereof, from Houser's electronic file. Such a removal would not damage the electronic file in the sense it would still contain the data for display upon being opened by the application program designed to open it.

Third, modifying as suggested by the examiner would result in Holme's electronic file, having a single data block 8. Each time the single data block 8 is overwritten by a new document modifier, the verification data and identity data entered at the same location by the prior document modifier would be lost. Consequently, the proposed modification would result in a system in which the list of users that modified Holmes' file would be lost. That is contrary to Holmes purpose, which is identifying unauthorized copies of data files and the source of the unauthorized copies of the data files. Holmes, *objects of the invention* section.

Fourth, assuming arguendo a combination in which Holmes data block 8 was replaced, in view of Houser, by a sequence of OLE objects, what would result would be an electronic file as described by Houser, except that the electronic file could be some software application. In this hypothetical combination, the combination would still lack claim 32's "watermark encoding at least one first license code." In this hypothetical combination, the combination would also lack the predetermined location of the data block 8 (because more than one OLE object was added) and the location of the OLE objects would not be at the predetermined location taught by Holmes. Holmes teaches system reliance on the predetermined location in order access the tracking data in the data block 8. This would present a complication not discussed in Holmes; how to find multiple locations for which there is no predetermined specification, and therefore

teaches away from the this hypothetical combination.

VII.D CLAIM 35, 103 REJECTION, HOLMES AND HOUSER, (CLAIMS 35-36)

The examiner erred by improperly construing the claims, mischaracterizing the prior art, and drawing improper conclusion regarding motivation to modify Holmes based upon Houser and knowledge of one of ordinary skill in the art.

35. (Previously Presented) The process of claim 32, wherein said watermark is accessible with a key.

Claims 35 and 36 relate to the linking of the watermark encoded first license code with accessing the specified functionality, of the modified software. Our specification contains the following relevant description:

[0006] Digital watermarks can be used to mark each individual copy of a digitized work with information identifying the title, copyright holder, and even the licensed owner of a particular copy. When marked with licensing and ownership information, responsibility is created for individual copies where before there was none. **Computer application programs can be watermarked by watermarking digital content resources used in conjunction with images or audio data[.]** **Digital watermarks can be encoded with random or pseudo random keys, which act as secret maps for locating the watermarks. These keys make it**

impossible for a party to find the watermark without having the key.

[0013] The present invention includes an application of the technology of "digital watermarks."

[0054] The first method of the present invention described involves hiding necessary "parts" or code "resources" in digitized sample resources using a "digital watermarking" process, **such as that described in the "Steganographic Method and Device" patent application.** ***

[0056] ... **For the encoding of the essential code resources, a "key" is needed.** Such a key is similar to those described in U.S. Pat. No. 5,613,004, the "Steganographic Method and Device" patent. ... This method, then, is to choose the key so that it corresponds, is equal to, or is a function of, a license code or license descriptive information, not just a text file, audio clip or identifying piece of information as desired in digital watermarking schemes extant and typically useful to stand-alone, digitally sampled content. The key is necessary to access the underlying code, i.e., what the user understands to be the application program.

[0057] **The assembly utility can be supplied with a key** generated from a license code generated for the license in question. Alternatively, the key, possibly random, can be stored as a data resource and encrypted with a derivative

of the license code. **Given the key, it encodes one or several essential resources into one or several data resources.**

These passages clarify that "accessible with a key" means a key for a digital watermark. That is what is used to find the watermark and therefore *access* the information the watermark encodes, assuming the watermark encodes any information.

Claim 35's "key" therefore means that the key that enables identification of the watermark bits, so the watermark and any data it encodes is "accessible". Houser discloses no corresponding key.

Houser discloses a visible watermark for the purpose of having a user visually confirm the existence of the watermark and associated digitized signature/chop. Houser's "key" disclosure is for a different concept, public/private key encryption. And Houser's keys are disclosed for the purpose encryption of the Houser's security information. As stated in Houser's abstract:

The security information may include a document digest that characterizes the electronic document at the time the security object was embedded, a signature digest that identifies the signator and that characterizes the instance of the embedded security object, and the signator's electronic chop, which may be the signator's digitized signature or other graphic image. In addition, **the security information can be encrypted** using either private key encryption or public key encryption. When the electronic document is later displayed, the identifier invokes processing that **decrypts the security information** and calculates the

document digest based on the current state of the electronic document.

Houser goes on in the Abstract to explain that its key decryption, is merely used to control the visual notification to the user, in a decision whether to display the electronic chop:

The signator of the electronic document can be verified based upon the result of the decryption. The integrity of the electronic document can be verified if the decrypted document digest matches the calculated document digest. *If the signator and the document integrity are confirmed, the electronic chop is displayed in the document.* If, however, the signator or document integrity are not verified, *the electronic chop is not displayed.* In addition, a warning message may be displayed if verification fails.

Houser's visible watermarks are not encoded with any data. Therefore, Houser's watermarks are not accessible. Houser discloses the user views the watermark superimposed on the electronic chop. That is the only purpose Houser identifies for a watermark. Viewing a watermark superimposed on an electronic chop is not accessing the watermark. Therefore, Houser's use of a key to decrypt in order to make the watermark superimposed on the electronic chop visible is no making the watermark accessible. Therefore, Houser does not disclose a watermark accessible with a key. Therefore, Holmes and Houser do not disclose claim 35's watermark "accessible with a key."

The examiner states that Houser teaches a watermark accessible with a key, citing Houser column 9 lines 37-60. But this passage in Houser is what discloses the public/private key concept just discussed. Houser's key decrypts Houser's security object, it does not provide access to a watermark, as defined by claim 35. Houser does not disclose encoding information in a watermark. Accordingly, Houser fails to disclose a watermark that is accessible with a key. Thus, nothing in Houser would suggest modifying Holmes to have such a feature.

VII.E CLAIM 36, 103 REJECTION, HOLMES AND HOUSER, (CLAIM 36)

The examiner erred by improperly construing the claims, mischaracterizing the prior art, and drawing improper conclusion regarding motivation to modify Holmes based upon Houser and knowledge of one of ordinary skill in the art.

36. (Previously Presented) The process of claim 35 [sic; said watermark is accessible with a key] wherein said key enables said first license code encoded watermarked software to provide said specified functionality.

Claim 36 defines that, same key that enables access to the watermark encoding the first license code, also enables the software to provide its specified functionality. Corresponding embodiments in our specification explain that "[0054] The first method of the present invention described involves hiding necessary "parts" or code "resources" in digitized sample resources using a "digital watermarking" process, such as that described in the "Steganographic Method and Device" patent application. The basic premise for this scheme is that there are a certain

sub-set of executable code resources, that comprise an application and that are "essential" to the proper function of the application. In general, any code resource can be considered "essential" in that if the program proceeds to a point where it must "call" the code resource and the code resource is not present in memory, or cannot be loaded, then the program fails. ... [0056] ...The end result will be that these essential code resources are not stored in their own partition, but rather stored as encoded information in data resources. They are not accessible at run-time without the key. ...[0057] The assembly utility can be supplied with a key generated from a license code generated for the license in question. ... The application can then operate as follows: [0058] 1) when it is run for the first time, after installation, it asks the user for personalization information, which includes the license code. This can include a particular computer configuration; [0059] 2) it stores this information in a personalization data resource; [0060] 3) Once it has the license code, it can then generate the proper decoding key to access the essential code resources." Thus, claim 36 requires a key to access the watermark, aka the first license code encoded in the watermark, and the key is also required for the software to function. Our example of how the key is required for the software to function, as cited from our specification paragraph 54 and 56-60 herein above, is one in which the key is derived from the license code and required for the software to decode its essential code resources. Neither Holmes nor Houser disclose or suggest encoding a watermark such that the watermark is accessible with a key (as defined by claim 35) or that the same key is also required to enable the software to function ("provide said specified functionality"), as further defined by claim 36.

The examiner cites Holmes column 3 lines 16-17 as disclosing this concept. However, Holmes column 3 lines 16-17 merely discloses pattern matching, stating:

Viewed from a fourth aspect the invention provides a data processing system for producing a copy file from a master file characterized by means for searching to locate a predetermined block of data within said master file, and means for overwriting said predetermined block of data with data identifying said copy file.

As noted above, neither Holmes nor Houser discloses software protection. Holmes is audit tracking, and Houser is secure audit tracking, and visual verification by the user. Thus, neither disclose their (data blocks for Holmes, and security objects for Houser) preventing software from providing a specified functionality. Therefore, neither disclose that a key enabling access to a license code encoded in watermarked software is the same key that enables the software to provide the specified functionality. Accordingly, neither disclose or suggest what claim 36 defines.

VII.F CLAIM 37, 103 REJECTION, HOLMES AND HOUSER, (CLAIM 37)

The examiner erred by improperly construing the claims, mischaracterizing the prior art, and drawing improper conclusion regarding motivation to modify Holmes based upon Houser and knowledge of one of ordinary skill in the art.

37. (Currently Amended) The process according to claim 35, wherein said first license code encoded watermarked software is configured to determine said key from said personalization information.

Claim 37's limitation corresponds to the following disclosure in our specification:

[0057] ... The application can then operate as follows:

[0058] 1) when it is run for the first time, after installation, it asks the user for personalization information, which includes the license code.

By definition, "personalization information" includes "the license code". [0058] ("personalization information, which includes the license code"). Claim 37 therefore defines a modified software having a watermark encoding a first license code which is configured to determine a key from inter alia the license code. Holmes and Houser are silent regarding license codes and therefore do not suggest claim 37's configuration, configured to determine a key from inter alia a license code.

VII.G CLAIM 38, 103 REJECTION, HOLMES AND HOUSER, (CLAIM 38)

The examiner erred by improperly construing the claims, mischaracterizing the prior art, and drawing improper conclusion regarding motivation to modify Holmes based upon Houser and knowledge of one of ordinary skill in the art.

38. (Original) The process according to claim 32, wherein the step of embedding the software with a watermark is performed during execution of the software.

As noted in our specification, "[0009] It is also desirable to randomly reorganize program memory structure intermittently during program run time, to prevent attempts at memory capture or object code analysis aimed at eliminating licensing or ownership information, or otherwise modifying, in an unintended manner, the functioning of the application." Neither Holmes nor Houser disclose embedding data into software while running the software. Accordingly, neither disclose claim 38's "embedding the software with a watermark is performed during execution of the software."

The examiner cited to Holmes column 3, lines 38-46. However, all that passage discloses is the data block 8 in the master file 6. That passage appears to be unrelated to claim 38.

VII.H CLAIM 40, 103 REJECTION, HOLMES AND HOUSER, (CLAIMS 40-45)

The examiner erred by improperly construing the claims, mischaracterizing the prior art, and drawing improper conclusion regarding motivation to modify Holmes based upon Houser and knowledge of one of ordinary skill in the art.

40. (Previously Presented) An article of manufacture comprising a machine readable medium, having thereon stored instructions adapted to be executed by a processor of a computer system, said computer system including a memory, which instructions when executed by said computer system result in a process comprising:

said computer system storing a software in said memory;

said computer system receiving licensing information as an input and

using said licensing information in an algorithm to identify a watermark in said software.

Review of the examiner's basis for rejection at the 9-20-2011 second FOA, page 4 items 4.a, fails to disclose an explanation why Holmes and Houser disclose this recitation. The appellant submits that there is no prima facie case to be rebutted, for claim 40.

Claim 40 defines "said computer system receiving licensing information as an input and using said licensing information in an algorithm to identify a watermark in said software." Neither Holmes nor Houser disclose using received licensing information to identify a watermark in software. Nothing in Houser and Holmes suggest using licensing information to identify a watermark in software. Holmes admittedly has no watermark. Houser does not disclose use of licensing information. Claim 40 is non-obvious in view of Houser and Holmes.

VII.I CLAIM 41, 103 REJECTION, HOLMES AND HOUSER, (CLAIMS 41, 43-44)

The examiner erred by improperly construing the claims, mischaracterizing the prior art, and drawing improper conclusion regarding motivation to modify Holmes based upon Houser and knowledge of one of ordinary skill in the art.

41. (Previously Presented) The article of manufacture of claim 40, wherein said watermark encodes therein information defining an executable code providing a functionality of said software.

Review of the examiner's basis for rejection at the 9-20-2011 second FOA, page 4 items 4.a, fails to disclose an explanation why Holmes and Houser disclose "watermark encodes therein information defining an executable code providing a functionality of said software." The appellant submits that there is no prima facie case to be rebutted, for claim 41's limitation.

However, nothing in Houser and Holmes suggest a watermark encoding information defining executable code providing a functionality to software.

Our specification provides the following relevant disclosures.

[0008] It is desirable to use a "stega-cipher" or watermarking process to hide the necessary parts or resources of the executable object code in the digitized sample resources. It is also desirable to further modify the underlying structure of an executable computer application such that it is more resistant to attempts at patching and analysis by memory capture.

[0032] It is thus a goal of the present invention, to provide a level of security for executable code on similar grounds as that which can be provided for digitized samples.

[0056] One method of the present invention is now discussed. When code and data resources are compiled and assembled into a precursor of an executable program the next step is to use a utility application for final assembly of the

executable application. The programmer marks several essential code resources in a list displayed by the utility. The utility will choose one or several essential code resources, and encode them into one or several data resources using the stegacipher process. **The end result will be that these essential code resources are not stored in their own partition, but rather stored as encoded information in data resources. They are not accessible at run-time without the key**

[0057] **The assembly utility can be supplied with a key generated from a license code generated for the license *in question*.** Alternatively, the key, possibly random, can be stored as a data resource and encrypted with a derivative of the license code. Given the key, it encodes one or several essential resources into one or several data resources.

Neither Holmes nor Houser disclose anything relevant to claim 41, or the supporting disclosure quoted herein above.

VII.J CLAIM 42, 103 REJECTION, HOLMES AND HOUSER, (CLAIM 42)

The examiner erred by improperly construing the claims, mischaracterizing the prior art, and drawing improper conclusion regarding motivation to modify Holmes based upon Houser and knowledge of one of ordinary skill in the art.

42. (Original) The article of manufacture of claim 40, wherein the watermark affects functionality of the watermarked software.

The examiner cites Holmes column 3 line 67, to column 4 line 4 as disclosing claim 42's limitation, reasoning that "the protection affects the functionality of the software by first running an verification process before execution." The appellant disagrees because Holmes at columns 3 and 4 does not disclose a verification process; it discloses copying a master file 6 containing a block of data 8. The examiner admits that Holmes does not disclose a watermark. In any case, the file of Holmes is treated in Holmes as a data file subject to copy and change. It is not disclosed to be a file that executes, and therefore master file 6 is not affected by any verification process run by some other software upon it. If the examiner meant instead to cite to Houser, the same rationale applies. Houser's security object, and Houser's electronic files are data upon which Houser discloses other software applications act. Accordingly, Houser also does not disclose its security object affecting its functionality, to the extent it has any.

VII.K CLAIM 43, 103 REJECTION, HOLMES AND HOUSER, (CLAIMS 43-44)

The examiner erred by improperly construing the claims, mischaracterizing the prior art, and drawing improper conclusion regarding motivation to modify Holmes based upon Houser and knowledge of one of ordinary skill in the art.

43. (Previously Presented) The article of manufacture of claim 41, wherein said instructions comprise decode instructions for said computer system

to use said information to generate a decode key for decoding said software.

Claim 43's "said instructions" means "instructions adapted to be executed by a processor of a computer system". Claim 40.

Claim 43's "said information" means "information defining an executable code providing a functionality of said software". Claim 41.

Thus, claim 43 defines "The article of manufacture of claim 41, wherein said instructions [sic; instructions adapted to be executed by a processor of a computer system] comprise decode instructions for said computer system to use said information [sic; information defining an executable code providing a functionality of said software] to generate a decode key for decoding said software.

The examiner cites Holmes column 3 line 67 to column 4 line for "identification data used to verify/decode the software for installation/copying)" in rejecting claim 43. However, that assertion fails to allege that Holmes discloses using information defining an executable code providing a functionality of said software to generate a decode key for decoding said software. Accordingly, there is no basis for the rejection of claim 43.

In any case, claim 43 relates to the following disclosure in our specification:

The application can then operate as follows:

[0058] 1) when it is run for the first time, after installation, it asks the user for personalization information, which includes the license code. This can include a particular computer configuration;

[0059] 2) it stores this information in a personalization data resource;

[0060] 3) **Once it has the license code, it can then generate the proper decoding key to access the essential code resources.**

VII.L CLAIM 44, 103 REJECTION, HOLMES AND HOUSER, (CLAIM 44)

The examiner erred by improperly construing the claims, mischaracterizing the prior art, and drawing improper conclusion regarding motivation to modify Holmes based upon Houser and knowledge of one of ordinary skill in the art.

44. (Previously Presented) The article of manufacture of claim 43, wherein said identifying information comprises a license key, and said decode instructions instruct said computer to determine said license key from said information and to generate said decode key using said license key.

Claim 43's limitations are non obvious for reasons similar to claim 43. However, claim 44 also requires using the decode key using the license key. This feature is also lacking from Holmes and Houser.

VII.M CLAIM 45, 103 REJECTION, HOLMES AND HOUSER, (CLAIM 45)

The examiner erred by improperly construing the claims, mischaracterizing the prior art, and drawing improper conclusion regarding motivation to modify Holmes based upon Houser and knowledge of one of ordinary skill in the art.

45. (Previously Presented) The article of manufacture of claim 40:
wherein said watermark encodes a license key;
said instructions include a prompt to enter licensing information;
wherein said software provides a certain functionality after receipt of
licensing information in response to said prompt only if said licensing information
comprises a license key encoded in said watermark.

Claim 45 limits the software to providing "a certain functionality ... only if" the licensing information received into the software "comprises a license key encoded in said watermark." That expressly ties the licensing information to the functional aspect of unlocking the software so that it provides the intended function, as noted in our specification. As noted in our specification:

[0056] ... This method, then, is to choose the key so that it corresponds, is equal to, or is a function of, a license code or license descriptive information, not just a text file, audio clip or identifying piece of information as desired in digital watermarking schemes extant and typically useful to stand-alone, digitally sampled content. The key is necessary to access the underlying code, i.e., what the user understands to be the application program.

Review of the examiner's basis for rejection at the 9-20-2011 second FOA, page 4 items 4.a, fails to disclose an explanation why Holmes and Houser disclose "said software provides a

certain functionality after receipt of licensing information in response to said prompt only if said licensing information comprises a license key encoded in said watermark." The appellant submits that there is no prima facie case to be rebutted, for claim 45.

In any case, nothing in Houser and Holmes suggest this concept.

VII.N CLAIM 52, 103 REJECTION, HOLMES AND HOUSER, (CLAIMS 52-57)

The examiner erred by improperly construing the claims, mischaracterizing the prior art, and drawing improper conclusion regarding motivation to modify Holmes based upon Houser and knowledge of one of ordinary skill in the art.

52. (Previously Presented) A computer-based system for modifying software, comprising:

- a computer having a processor and memory;
- wherein said computer is programmed to receive software that provides a specified functionality when installed on a computer system;
- wherein said computer is programmed to embed a watermark into said software;
- wherein said watermark encodes at least one first license code, thereby resulting in a first license code encoded watermarked software.

Claim 52 is a system analog of method claim 32. Its rejection is improper for the same reasons as claim 32.

VII.O CLAIM 53, 103 REJECTION, HOLMES AND HOUSER, (CLAIMS 53, 55)

The examiner erred by improperly construing the claims, mischaracterizing the prior art, and drawing improper conclusion regarding motivation to modify Holmes based upon Houser and knowledge of one of ordinary skill in the art.

53. (Previously Presented) The system of claim 52 wherein said computer is programmed to use said at least one first license code as an input in an algorithm for embedding said watermark with said at least one first license code.

Claim 53 expressly recites a computer programmed to use an algorithm to embed a watermark encoding a license code. Neither Holmes nor Houser disclose a system configured to embed a watermark storing a licence code. The examiner presents the same reasons for the rejections of claims 35 and 53. However, the examiner's reasoning referred to the public/private key encryption of Houser's security object, in Houser column 9. There is nothing in Houser column 9 disclosing a computer programmed to use an algorithm to embed a watermark storing a licence code. Houser fails to disclose a watermark encoding a license code. Therefore, rejection of claim 53 is improper.

VII.P CLAIM 54, 103 REJECTION, HOLMES AND HOUSER, (CLAIM 54)

The examiner erred by improperly construing the claims, mischaracterizing the prior art, and drawing improper conclusion regarding motivation to modify Holmes based upon Houser

and knowledge of one of ordinary skill in the art.

54. (Previously Presented) The system of claim 52 wherein said first license code encoded watermarked software is designed to prompt for entry of licensing information and only provides a certain functionality if licensing information entered in response to said prompt comprises at least one of said at least one first license code encoded in said watermark.

Claim 54's recitation "only provides a certain functionality if licensing information entered in response to said prompt comprises at least one of said at least one first license code encoded in said watermark" specifically ties the "at least one first license code" to the "licensing information" by requiring those pieces of information correspond in order to provide the software's "certain functionality."

The examiner applied the same reasoning to reject claim 54 as claim 34, citing to Holmes columns 3 line 67 to column 4 line 12, for allegedly disclosing "verifying the embedded identification data during software installation/copying". Holmes columns 3 line 67 to column 4 line 12 merely discloses appending a checksum value into the block of data 8. It does not provide a "functionality" only if licensing information matches a first license code encoded in the master file. Similarly, Houser contains no mechanism to prevent use and further editing of its electronic file. Claim 54 defines such a mechanism (to prevent software from functioning unless certain stored and entered data correspond to one another).

VII.Q CLAIM 55, 103 REJECTION, HOLMES AND HOUSER, (CLAIM 55)

The examiner erred by improperly construing the claims, mischaracterizing the prior art, and drawing improper conclusion regarding motivation to modify Holmes based upon Houser and knowledge of one of ordinary skill in the art.

55. (Previously Presented) The system of claim 53, wherein said at least one first license code is fixed prior to distribution of the software.

Review of the examiner's basis for rejection at the 9-20-2011 second FOA, page 4 items 4.a, fails to disclose an explanation why Holmes and Houser disclose "first license code is fixed prior to distribution of the software." The appellant submits that there is no prima facie case to be rebutted, for claim 55.

In any case, nothing in Houser and Holmes suggest this concept. Neither discloses embedding a license code. Neither discloses distribution. Neither discloses that the license code is fixed prior to distribution of the software.

In any case, the concept defined by claim 55 relates to the following disclosure in our specification.

[0057] The assembly utility can be supplied with a key generated from a license code generated for the license in question. Alternatively, the key, possibly random, can be stored as a data resource and encrypted with a derivative of the license code. **Given the key, it encodes one or several essential resources into**

one or several data resources. Exactly which code resources are encoded into which data resources may be determined in a random or pseudo random manner. Note further that the application contains a code resource which performs the function of decoding an encoded code resource from a data resource. The application must also contain a data resource which specifies in which data resource a particular code resource is encoded. This data resource is created and added at assembly time by the assembly utility.

VII.R CLAIM 58, 103 REJECTION, HOLMES AND HOUSER, (CLAIM 58)

The examiner erred by improperly construing the claims, mischaracterizing the prior art, and drawing improper conclusion regarding motivation to modify Holmes based upon Houser and knowledge of one of ordinary skill in the art.

58. (Previously Presented) A method for licensed software use, the method comprising:

- loading a software product on a computer, said computer comprising a processor, memory, an input, and an output, so that said computer is programmed to execute said software product;
- said software product outputting a prompt for input of license information;
- and
- said software product using license information entered via said input in response to said prompt in a routine designed to decode a first license code

encoded in said software.

Neither Holmes nor Houser disclose or suggest the concept of "said software product using license information entered via said input in response to said prompt in a routine designed to decode a first license code encoded in said software." That concept is disclosed in paragraphs [0056] to [0060], and as discussed herein above.

Review of the examiner's basis for rejection at the 9-20-2011 second FOA, page 4 items 4.a, fails to disclose an explanation why Holmes and Houser disclose a "software product using license information entered via said input in response to said prompt in a routine designed to decode a first license code encoded in said software." The appellant submits that there is no prima facie case to be rebutted, for claim 58.

In any case, nothing in Houser and Holmes suggest using input license information to "decode a first license code encoded in said software."

VII.S CLAIM 59, 103 REJECTION, HOLMES AND HOUSER, (CLAIMS 59-60)

The examiner erred by improperly construing the claims, mischaracterizing the prior art, and drawing improper conclusion regarding motivation to modify Holmes based upon Houser and knowledge of one of ordinary skill in the art.

59. (Previously Presented) A method for encoding software code using a computer having a processor and memory, comprising:
storing a software code in said memory;

wherein said software code comprises a first code resource and provides a specified underlying functionality when installed on a computer system; and encoding, by said computer using at least a first license key and an encoding algorithm, said software code, to form a first license key encoded software code.

Claim 59 is similar in scope to claim 32, and allowable over Holmes and Houser for the reasons that apply to claim 32. Claim 59 also specifies that the software comprises a code resource.

VII.T CLAIM 60, 103 REJECTION, HOLMES AND HOUSER, (CLAIM 60)

The examiner erred by improperly construing the claims, mischaracterizing the prior art, and drawing improper conclusion regarding motivation to modify Holmes based upon Houser and knowledge of one of ordinary skill in the art.

60. (Previously Presented) The method of claim 59 wherein, when installed on a computer system, said first license key encoded software code will provide said specified underlying functionality only after receipt of said first license key.

Claim 60 expressly ties the functioning of the software to receipt by said software, of the same license key, the first license key, already encoded in the software. That is what "only after

receipt of said first license key" requires.

The examiner applied the same reasoning to reject claims 36 and 60, citing Holmes column 4 lines 16-17, for allegedly disclosing "executing/copying the software code based on successful verification." However, Holmes column 3 lines 16-17 merely discloses pattern matching, stating:

Viewed from a fourth aspect the invention provides a data processing system for producing a copy file from a master file characterized by means for searching to locate a predetermined block of data within said master file, and means for overwriting said predetermined block of data with data identifying said copy file.

As noted above, neither Holmes nor Houser discloses software protection. Holmes is audit tracking, and Houser is secure audit tracking, and visual verification by the user. Thus, neither disclose their (data blocks for Holmes, and security objects for Houser) preventing software from providing a specified functionality. Therefore, neither disclose that a key enabling access to a license code encoded in watermarked software or that such a key is the same key that enables the software to provide the specified functionality.

Moreover, neither disclose that only receipt by the software of the first licence key already encoded in the software is required to obtain from the software its "specified underlying functionality."

Accordingly, claim 60 is not obvious.

VII.U CLAIM 61, 103 REJECTION, HOLMES AND HOUSER, (CLAIM 61)

The examiner erred by improperly construing the claims, mischaracterizing the prior art, and drawing improper conclusion regarding motivation to modify Holmes based upon Houser and knowledge of one of ordinary skill in the art.

61. (Previously Presented) A method for encoding software code using a computer having a processor and memory, comprising:

- storing a software code in said memory;
- wherein said software code comprises a first code resource and provides a specified underlying functionality when installed on a computer system; and
- modifying, by said computer, using a first license key and an encoding algorithm, said software code, to form a modified software code; and
- wherein said modifying comprises encoding said first code resource to form an encoded first code resource;
- wherein said modified software code comprises said encoded first code resource, and a decode resource for decoding said encoded first code resource;
- wherein said decode resource is configured to decode said encoded first code resource upon receipt of said first license key.

In rejecting claim 61, the examiner referred to rejections of claims 32 and 43. However, unlike claims 32 and 43, claim 61 requires modifying the software by "encoding said first code resource to form an encoded first code resource"; including in the software the "encoded first

code resource, and a decode resource for decoding said encoded first code resource;" where "decode resource is configured to decode said encoded first code resource"; and wherein that decoding occurs "upon receipt of said first license key." These limitations are not addressed in the basis for rejection of claims 32 and 43. Accordingly, the second FOA apparently lacks a prima facie case, to state a basis for rejecting claim 62.

In any case, our application contains disclosures relevant to these claim limitations, some of which are quoted below.

[0013] ... this invention, which focuses on watermarking with "keys" derived from license codes or other ownership identification information, and using the watermarks encoded with such keys **to hide an essential subset of the application code resources.**

[0060] 3) **Once it has the license code, it can then generate the proper decoding key** to access the essential code resources.

Neither Holmes nor Houser disclose the foregoing claim 61 limitations.

VII.V CLAIM 62, 103 REJECTION, HOLMES AND HOUSER, (CLAIM 62)

The examiner erred by improperly construing the claims, mischaracterizing the prior art, and drawing improper conclusion regarding motivation to modify Holmes based upon Houser and knowledge of one of ordinary skill in the art.

62. (Previously Presented) A method for encoding software code using a computer having a processor and memory, comprising:

- storing a software code in said memory;
- wherein said software code defines software code interrelationships between code resources that result in a specified underlying functionality when installed on a computer system; and
- encoding, by said computer using at least a first license key and an encoding algorithm, said software code, to form a first license key encoded software code in which at least one of said software code interrelationships are encoded.

Claim 62 defines encoding of software code interrelationships, which are the relationships between code resources that result in a specified underlying functionality. This corresponds to the following disclosure in our specification:

[0013] ... disclosed in this invention, which focuses on watermarking with "keys" derived from license codes or other ownership identification information, and using the watermarks encoded with such keys **to hide an essential subset of the application code resources.**

[0051] ... The order in which the programmer types the code for the various functions or procedures, and the distribution of and arrangement of these

implementations in various files which hold them is unimportant. **Within a function or procedure, however, the order of individual language constructs, which correspond to particular machine instructions is important, and so functions or procedures are considered indivisible for purposes of this discussion. That is, once a function or procedure is compiled, the order of the machine instructions which comprise the executable object code of the function is important and their order in the computer memory is of vital importance.** Note that many "compilers" perform "optimizations" within functions or procedures, which determine, on a limited scale, if there is a better arrangement for executable instructions which is more efficient than that constructed by the programmer, but does not change the result of the function or procedure. **Once these optimizations are performed, however, making random changes to the order of instructions is very likely to "break" the function.** When a program is compiled, then, it consists of a collection of these sub-objects, whose exact order or arrangement in memory is not important, so long as any sub-object which uses another sub-object knows where in memory it can be found.

[0052] **The memory address of the first instruction in one of these sub-objects is called the "entry point" of the function or procedure. The rest of the instructions comprising that sub-object immediately follow from the entry point.** Some systems may prefix information to the entry point which describes

calling and return conventions for the code which follows, an example is the Apple Macintosh Operating System (MacOS). These sub-objects can be packaged into what are referred to in certain systems as "code resources," which may be stored separately from the application, or shared with other applications, although not necessarily. Within an application there are also data objects, which consist of some data to be operated on by the executable code. These data objects are not executable. That is, they do not consist of executable instructions. The data objects can be referred to in certain systems as "resources."

Neither Holmes nor Houser disclose or suggest software code "in which at least one of said software code interrelationships are encoded" with the encoding "using at least a first license key and an encoding algorithm". Neither Holmes nor Houser disclose encoding code interrelationships, for example, such as absolute or relative entry point memory addresses between code resources.

The second FOA cited (at page 8) the rejections of claims 32 and 61 as the sole basis for rejection of claim 62-64. In rejecting claim 61, the examiner referred to rejections of claims 32 and 43. In reviewing the rejections of claims 32, 43, and 61, there does not appear to be any basis in them for rejection of claim 62; no prima facie case to rebut. Claim 62 defines limitations relative to software code interrelationships between code resources. ("wherein said software code defines software code interrelationships between code resources ... encoding, ... said software code, ... in which at least one of said software code interrelationships are encoded.") In contrast, claim 32 does not define code resources; claim 43 relates to decode instructions to

generate a decode key; claim 61 relates to encoded code resource, and a decode resource. In any case, neither Holmes nor Houser disclose or suggest encoding code interrelationships between code resources of the software.

VII.W CLAIM 63, 103 REJECTION, HOLMES AND HOUSER, (CLAIMS 63-64)

The examiner erred by improperly construing the claims, mischaracterizing the prior art, and drawing improper conclusion regarding motivation to modify Holmes based upon Houser and knowledge of one of ordinary skill in the art.

63. (Previously Presented) A method for encoding software code using a computer having a processor and memory, comprising:

- storing a software code in said memory;
- wherein said software code provides a specified underlying functionality when installed on a computer system;
- encoding, by said computer using at least a first license key and an encoding algorithm, said software code, to form a first license key encoded software code;
- encoding, by said computer using at least a second license key and an encoding algorithm, said software code, to form a second license key encoded software code;
- wherein said first license key encoded software code is not identical to said second license key encoded software code if said first license key is not

identical to said second license key.

64. (Previously Presented) The method of claim 63 wherein both said first license key encoded software code and said second license key encoded software code are capable of providing said specified underlying functionality when installed on a computer system.

Both claims 63 and 64 define substantially the same subject matter as claim 32, except that these claims do not define encoding the license code in a watermark embedded in the software. These claims are non obvious over Holmes and Houser because Holmes and Houser fail to disclose or suggest encoding software with a license code for that software. As noted in the summary of the file history and construction of claim 32, the claims reciting a first license code mean a license code capable of unlocking the software. As noted in our specification, "[0057] The assembly utility can be supplied with a key generated from a license code generated *for the license in question.*" The claimed license logically means the license in question, the one that unlocks the software so it provides ".the underlying code, i.e., what the user understands to be the application program." [0056], last sentence.

SIGNATURE:

/RichardNeifeld/
RICHARD NEIFELD, REGISTRATION NO 35,299
ATTORNEY OF RECORD

RAN

Date/time: May 12, 2012 (1:22pm)

Y:\Clients\SCOT Scott A Moskowitz and Wistaria Trading,
Inc\SCOT0014-4\Drafts\AppealBrief_SCOT0014-4_5-6-2012.wpd

VIII. 37 CFR 41.37(c)(1)(v) - CLAIMS APPENDIX

1-31. (Canceled)

32. (Previously Presented) A computer-based method for modifying software, comprising:

receiving, in a computer having a processor and memory, software, wherein said software provides a specified functionality;

embedding a watermark into said software, using said computer, said watermark encoding at least one first license code, thereby resulting in a first license code encoded watermarked software.

33. (Previously Presented) The process of claim 32, wherein said embedding increases the complexity of code analysis and/or tampering with said first license code encoded watermarked software.

34. (Previously Presented) The process of claim 32, wherein said first license code encoded watermarked software is configured to query a user for personalization information during its installation.

35. (Previously Presented) The process of claim 32, wherein said watermark is accessible with a key.

36. (Previously Presented) The process of claim 35 wherein said key enables said first license code encoded watermarked software to provide said specified functionality.

37. (Previously Presented) The process according to claim 35, wherein said first license code encoded watermarked software is configured to determine said key from said personalization information.

38. (Original) The process according to claim 32, wherein the step of embedding the software with a watermark is performed during execution of the software.

39. (Previously Presented) The process according to claim 32, wherein said embedding modifies the structure of said software.

40. (Previously Presented) An article of manufacture comprising a machine readable medium, having thereon stored instructions adapted to be executed by a processor of a computer system, said computer system including a memory, which instructions when executed by said computer system result in a process comprising:

said computer system storing a software in said memory;

said computer system receiving licensing information as an input and using said licensing information in an algorithm to identify a watermark in said software.

41. (Previously Presented) The article of manufacture of claim 40, wherein

said watermark encodes therein information defining an executable code providing a functionality of said software.

42. (Original) The article of manufacture of claim 40, wherein the watermark affects functionality of the watermarked software.

43. (Previously Presented) The article of manufacture of claim 41, wherein said instructions comprise decode instructions for said computer system to use said information to generate a decode key for decoding said software.

44. (Previously Presented) The article of manufacture of claim 43, wherein said identifying information comprises a license key, and said decode instructions instruct said computer to determine said license key from said information and to generate said decode key using said license key.

45. (Previously Presented) The article of manufacture of claim 40:
wherein said watermark encodes a license key;
said instructions include a prompt to enter licensing information;
wherein said software provides a certain functionality after receipt of licensing information in response to said prompt only if said licensing information comprises a license key encoded in said watermark.

46 – 51. (Canceled)

52. (Previously Presented) A computer-based system for modifying software, comprising:

a computer having a processor and memory;

wherein said computer is programmed to receive software that provides a specified functionality when installed on a computer system;

wherein said computer is programmed to embed a watermark into said software;

wherein said watermark encodes at least one first license code, thereby resulting in a first license code encoded watermarked software.

53. (Previously Presented) The system of claim 52 wherein said computer is programmed to use said at least one first license code as an input in an algorithm for embedding said watermark with said at least one first license code.

54. (Previously Presented) The system of claim 52 wherein said first license code encoded watermarked software is designed to prompt for entry of licensing information and only provides a certain functionality if licensing information entered in response to said prompt comprises at least one of said at least one first license code encoded in said watermark.

55. (Previously Presented) The system of claim 53, wherein said at least one first license code is fixed prior to distribution of the software.

56. (Previously Presented) The system of claim 52 wherein said at least one first license code comprises computer code that provides different functionality to said first license code encoded watermarked software compared to said software.

57. (Previously Presented) The system of claim 52, wherein said first license code encoded watermarked software is resistant to code analysis and/or tampering.

58. (Previously Presented) A method for licensed software use, the method comprising:

loading a software product on a computer, said computer comprising a processor, memory, an input, and an output, so that said computer is programmed to execute said software product;

said software product outputting a prompt for input of license information; and

said software product using license information entered via said input in response to said prompt in a routine designed to decode a first license code encoded in said software.

59. (Previously Presented) A method for encoding software code using a computer having a processor and memory, comprising:

storing a software code in said memory;

wherein said software code comprises a first code resource and provides a specified underlying functionality when installed on a computer system; and

encoding, by said computer using at least a first license key and an encoding algorithm,

said software code, to form a first license key encoded software code.

60. (Previously Presented) The method of claim 59 wherein, when installed on a computer system, said first license key encoded software code will provide said specified underlying functionality only after receipt of said first license key.

61. (Previously Presented) A method for encoding software code using a computer having a processor and memory, comprising:

- storing a software code in said memory;
- wherein said software code comprises a first code resource and provides a specified underlying functionality when installed on a computer system; and
- modifying, by said computer, using a first license key and an encoding algorithm, said software code, to form a modified software code; and
- wherein said modifying comprises encoding said first code resource to form an encoded first code resource;
- wherein said modified software code comprises said encoded first code resource, and a decode resource for decoding said encoded first code resource;
- wherein said decode resource is configured to decode said encoded first code resource upon receipt of said first license key.

62. (Previously Presented) A method for encoding software code using a computer having a processor and memory, comprising:

storing a software code in said memory;

wherein said software code defines software code interrelationships between code resources that result in a specified underlying functionality when installed on a computer system;
and

encoding, by said computer using at least a first license key and an encoding algorithm, said software code, to form a first license key encoded software code in which at least one of said software code interrelationships are encoded.

63. (Previously Presented) A method for encoding software code using a computer having a processor and memory, comprising:

storing a software code in said memory;

wherein said software code provides a specified underlying functionality when installed on a computer system;

encoding, by said computer using at least a first license key and an encoding algorithm, said software code, to form a first license key encoded software code;

encoding, by said computer using at least a second license key and an encoding algorithm, said software code, to form a second license key encoded software code;

wherein said first license key encoded software code is not identical to said second license key encoded software code if said first license key is not identical to said second license key.

64. (Previously Presented) The method of claim 63 wherein both said first license key encoded software code and said second license key encoded software code are

capable of providing said specified underlying functionality when installed on a computer system.

IX. 37 CFR 41.37(c)(2) - NON ADMITTED AMENDMENT OR EVIDENCE

The brief contains no non-admitted amendment or evidence.

X. 37 CFR 41.37(d) - NOTICE OF NON COMPLIANCE

This section is not relevant.

SIGNATURE:

/RichardNeifeld/
RICHARD NEIFELD, REGISTRATION NO 35,299
ATTORNEY OF RECORD

RAN

Date/time: May 12, 2012 (1:22pm)

Y:\Clients\SCOT Scott A Moskowitz and Wistaria Trading,
Inc\SCOT0014-4\Drafts\AppealBrief_SCOT0014-4_5-6-2012.wpd

Electronic Patent Application Fee Transmittal

Application Number:	11895388			
Filing Date:	24-Aug-2007			
Title of Invention:	Data protection method and device			
First Named Inventor/Applicant Name:	Scott A. Moskowitz			
Filer:	Richard A. Neifeld			
Attorney Docket Number:	SCOT0014-4			
Filed as Small Entity				
Utility under 35 USC 111(a) Filing Fees				
Description	Fee Code	Quantity	Amount	Sub-Total in USD(\$)
Basic Filing:				
Pages:				
Claims:				
Miscellaneous-Filing:				
Petition:				
Patent-Appeals-and-Interference:				
Filing a brief in support of an appeal	2402	1	310	310
Post-Allowance-and-Post-Issuance:				
Extension-of-Time:				

Description	Fee Code	Quantity	Amount	Sub-Total in USD(\$)
Miscellaneous:				
Total in USD (\$)				310

Electronic Acknowledgement Receipt

EFS ID:	12766365
Application Number:	11895388
International Application Number:	
Confirmation Number:	2103
Title of Invention:	Data protection method and device
First Named Inventor/Applicant Name:	Scott A. Moskowitz
Customer Number:	31518
Filer:	Richard A. Neifeld
Filer Authorized By:	
Attorney Docket Number:	SCOT0014-4
Receipt Date:	14-MAY-2012
Filing Date:	24-AUG-2007
Time Stamp:	11:50:12
Application Type:	Utility under 35 USC 111(a)

Payment information:

Submitted with Payment	yes
Payment Type	Credit Card
Payment was successfully received in RAM	\$ 310
RAM confirmation Number	9088
Deposit Account	502106
Authorized User	NEIFELD,RICHARD ALAN

The Director of the USPTO is hereby authorized to charge indicated fees and credit any overpayment as follows:

Charge any Additional Fees required under 37 C.F.R. Section 1.17 (Patent application and reexamination processing fees)

File Listing:

Document Number	Document Description	File Name	File Size(Bytes)/ Message Digest	Multi Part /.zip	Pages (if appl.)
1	Appeal Brief Filed	AppealBrief_SCOT0014-4_5-6-2012.pdf	328348 de65106b9ec15066363cc3d4059b05d861c7c06a	no	114

Warnings:**Information:**

2	Fee Worksheet (SB06)	fee-info.pdf	30042 65e669509e241ef13cf0d0e7a332db4053770946	no	2
---	----------------------	--------------	---	----	---

Warnings:**Information:**

Total Files Size (in bytes):	358390
-------------------------------------	--------

This Acknowledgement Receipt evidences receipt on the noted date by the USPTO of the indicated documents, characterized by the applicant, and including page counts, where applicable. It serves as evidence of receipt similar to a Post Card, as described in MPEP 503.

New Applications Under 35 U.S.C. 111

If a new application is being filed and the application includes the necessary components for a filing date (see 37 CFR 1.53(b)-(d) and MPEP 506), a Filing Receipt (37 CFR 1.54) will be issued in due course and the date shown on this Acknowledgement Receipt will establish the filing date of the application.

National Stage of an International Application under 35 U.S.C. 371

If a timely submission to enter the national stage of an international application is compliant with the conditions of 35 U.S.C. 371 and other applicable requirements a Form PCT/DO/EO/903 indicating acceptance of the application as a national stage submission under 35 U.S.C. 371 will be issued in addition to the Filing Receipt, in due course.

New International Application Filed with the USPTO as a Receiving Office

If a new international application is being filed and the international application includes the necessary components for an international filing date (see PCT Article 11 and MPEP 1810), a Notification of the International Application Number and of the International Filing Date (Form PCT/RO/105) will be issued in due course, subject to prescriptions concerning national security, and the date shown on this Acknowledgement Receipt will establish the international filing date of the application.



UNITED STATES PATENT AND TRADEMARK OFFICE

UNITED STATES DEPARTMENT OF COMMERCE
United States Patent and Trademark Office
Address: COMMISSIONER FOR PATENTS
P.O. Box 1450
Alexandria, Virginia 22313-1450
www.uspto.gov

Table with 5 columns: APPLICATION NO., FILING DATE, FIRST NAMED INVENTOR, ATTORNEY DOCKET NO., CONFIRMATION NO.
11/895,388 08/24/2007 Scott A. Moskowitz SCOT0014-4 2103

31518 7590 08/08/2012
NEIFELD IP LAW, PC
4813-B EISENHOWER AVENUE
ALEXANDRIA, VA 22304

Table with 1 column: EXAMINER

OKEKE, IZUNNA

Table with 2 columns: ART UNIT, PAPER NUMBER

2432

Table with 2 columns: NOTIFICATION DATE, DELIVERY MODE

08/08/2012

ELECTRONIC

Please find below and/or attached an Office communication concerning this application or proceeding.

The time period for reply, if any, is set in the attached communication.

Notice of the Office communication was sent electronically on above-indicated "Notification Date" to the following e-mail address(es):

general@neifeld.com
rneifeld@neifeld.com
rhahl@neifeld.com

Application/Control Number: 11/895,388

Page 1

Art Unit: 2432



UNITED STATES PATENT AND TRADEMARK OFFICE

Commissioner for Patents
United States Patent and Trademark Office
P.O. Box 1450
Alexandria, VA 22313-1450
www.uspto.gov

**BEFORE THE BOARD OF PATENT APPEALS
AND INTERFERENCES**

Application Number: 11895388

Filing Date: 08/24/2007

Appellant(s): Scott Moskowitz

Richard Neifeld
Reg. No 35,299
For Appellant

EXAMINER'S ANSWER

This is in response to the appeal brief filed 05/14/2012.

(1) Grounds of Rejection to be Reviewed on Appeal

The ground(s) of rejection set forth in the Office action dated 09/20/2011 from which the appeal is taken have been modified. A list of rejections withdrawn by the examiner (if any) is included under the subheading "WITHDRAWN REJECTIONS." New grounds of rejection (if any) are provided under the subheading "NEW GROUNDS OF REJECTION."

WITHDRAWN REJECTIONS

The following grounds of rejection are not presented for review on appeal because they have been withdrawn by the examiner. Claims 34, 45, 54 and 58 are withdrawn from 35 U.S.C. 103 rejection. Claims 34, 45 and 54 are objected to as being dependent upon a rejected base claim, but would be allowable if rewritten in independent form including all of the limitations of the base claim and any intervening claims. Claim 58 recites allowable subject matter.

(2) Response to Argument

Claims 32-45 and 52-64 are rejected under 35 USC 103 (a) as being unpatentable over Holmes et al. (US-5287407) and Houser et al. (US-5606609).

Appellant argues that the combination of Holmes and Houser does not disclose the claimed invention. In response, claim 32 recites a method for modifying software comprising embedding a watermark into a software (which provides a specified functionality) wherein the watermark encodes at least one first license code, thereby resulting in a first license code encoded watermarked software. The claim is directed to embedding a first license in software as a watermark. In Para 13 of appellant's specification, a license code is disclosed to comprise ownership identification information. So in essence, claim 32 is directed to embedding a watermark which encodes a first license code (ownership identification information) into

software. Holmes teaches a similar invention. Holmes teaches a software protection method wherein unique identifying data is embedded into software. Col 3, Lines 37 thru Col 4, Line 11 teaches unique identifying data (which is interpreted as the claimed license code) being embedded into software. In Col 1, Lines 61 thru Col 2, Line 4, Holmes discloses how this identifying information is embedded and from this recitation "*the predetermined block of data may be positioned anywhere within the master and copied files, it is difficult for an unauthorized copier to identify and remove the data identifying the copied file*" it is quite clear that the information is embedded as a "watermark". Holmes does not explicitly recite the embedded identification information as watermark but the use of watermarks to embed information in order to make it difficult to be tampered with is well known. The secondary reference, Houser et al, teaches such a "*difficult to forge*" watermark being used to embed information in software such as a file or video data (See Houser, Col 16, Line 59 thru Col 17, Line 1). It would be obvious to one of ordinary skill that the identification information (license code) embedded in the software as taught by Holmes is embedded using a watermarking process to make it difficult for the data to be identified or removed.

On pages 30-31 of appellant's brief, appellant argues that Holmes "embedded identification data" could not serve as the license code recited in the claims. Appellant's specification in Para 8, 13 and 56 discloses a key which is linked or derived from a license code or other ownership identification information. According to Para 56, the "key" corresponds/ is equal to the license code. When the software is embedded with this license code, the key or identifying information is needed before installation or use of the software (access the underlying code). From the disclosure, it is clear that the recited "license code" is identification information.

Art Unit: 2432

Holmes explicitly teaches the embedding of ownership identification data/code in software. In Fig. 1 and Col 3, Lines 39 thru Col 4, Line 2, Holmes teaches embedding identification data/code in software wherein the identification data uniquely identifies an authorized user (license code). In light of this disclosure and the explanation, Holmes “embedded unique identification data/code” serves as the license code recited in appellant's claims. The argument with respect to independent claims 52, 59, 62 and 63 is based on the argument with respect to independent claim 32 and the same response presented above applies to the argument.

For the above reasons, it is believed that the rejections should be sustained.

Respectfully submitted,

/IZUNNA OKEKE/
Examiner, Art Unit 2432

/Gilberto Barron Jr./
Supervisory Patent Examiner, Art Unit 2432

Conferees:

/Benjamin E Lanier/
Primary Examiner, Art Unit 2432

/Gilberto Barron Jr./
Supervisory Patent Examiner, Art Unit 2432

Neifeld Docket No: SCOT0014-4

Application/Patent No: 11/895,388

USPTO CONFIRMATION NO: 2103

File/Issue Date: 8/24/2007

Inventor/title: Moskowitz/ Data protection method and device

Examiner/ArtUnit: Izunna OKEKE/2432

ENTITY STATUS: SMALL (CONVERT UPON ALLOWANCE TO LARGE)

Priority: Application No. 09/046,627 (which issued July 22, 2003, as U.S. Patent No. 6,598,162)

**37 CFR 1.7© FILING RECEIPT AND TRANSMITTAL LETTER WITH
AUTHORIZATION TO CHARGE DEPOSIT ACCOUNT**

1. **THE COMMISSIONER IS HEREBY AUTHORIZED TO CHARGE ANY FEES WHICH MAY BE REQUIRED, OR CREDIT ANY OVERPAYMENT, TO DEPOSIT ACCOUNT NUMBER 50-2106.**

2. **FEES (PAID HEREWITH BY EFS CREDIT CARD SUBMISSION) \$**

A. **CLAIMS FEES**

B. **OTHER FEES**

3. **THE FOLLOWING DOCUMENTS ARE SUBMITTED HEREWITH:
37 CFR 41.41 REPLY BRIEF**

4. **FOR INTERNAL NEIFELD IP LAW, PC USE ONLY**

acct/ck/No/date/amnt: 6/SCOT0001/

Firm charge:

INITIALS OF PERSON WHO **ENTERED** ACCOUNTING DATA: RAN

ATTORNEY SIGNATURE (AUTHORIZING DEPOSIT ACCOUNT)

8/9/2012

/RichardNeifeld#35,299/

RICHARD NEIFELD, REG. NO. 35,299

ATTORNEY OF RECORD

Printed: August 13, 2012 (2:46pm)

Y:\Clients\SCOT Scott A Moskowitz and Wistaria Trading,

Inc\SCOT0014-4\Drafts\ReplyBrief_SCOT0014-4_8-9-2012.wpd

Neifeld Docket No: SCOT0014-4

Application/Patent No: 11/895,388

USPTO CONFIRMATION NO: 2103

File/Issue Date: 8/24/2007

Inventor/title: Moskowitz/ Data protection method and device

Examiner/ArtUnit: Izunna OKEKE/2432

ENTITY STATUS: SMALL (CONVERT UPON ALLOWANCE TO LARGE)

Priority: Application No. 09/046,627 (which issued July 22, 2003, as U.S. Patent No. 6,598,162)

37 CFR 41.41 REPLY BRIEF

WITHDRAWN REJECTIONS

At page 2, lines 9-12, the Answer withdraws the rejections of dependent claims Claims 34, 45 and 54 and of independent claim 58. Consequently, upon conclusion of the appeal, the examiner should be instructed to allow these claims.

RESPONSE TO MAINTAINED REJECTIONS

8/8/2012 Final Office Action FOA page 3 lines 21-22 states that "The Holmes teaches embedding an identification data into the software. Holmes does not teach embedding the data as a watermark." However, at Answer page 3 lines 1-4, the examiners state that "Holmes discloses ... information is embedded as a 'watermark.'"

The FOA goes on to rely upon Houser suggesting modifying Holmes based upon Houser's teaching by "embedding the identification data as a watermark". FOA page 5 line 2.

The Answer goes on to rely upon Houser for suggesting modifying Holmes, based upon Houser's teachings, by "embedded using a watermarking process to make it difficult for the data to be identified or removed."

The rejection in the Answer is not the rejection in the final office action. Both the

operative alleged facts (whether Holmes does not (as in the FOA) or does (as in the Answer) disclose a watermark and the underlying motivation to modify in the FOA (to watermark unwatermarked data) and in the Answer (to make the watermark more difficult to identify or remove) are different.

A new fact finding fundamental to a legal conclusion of unpatentability is a new ground of rejection. In re Stepan Co., Docket No. 2010-1261 (Fed. Cir. 10/5/2011)("Stepan is correct. By making and relying on new fact findings regarding an issue ... the Board relied on a new ground of rejection."). The rejection in the Answer, clearly, is a new ground of rejection.

The (current version of the often revised)rules for ex parte appeals specify that "The examiner must obtain the approval of the Director to furnish an answer that includes a new ground of rejection." 37 CFR 41.39(a)(2). The Answer is not signed by a Director. The highest ranking official signing the Answer has title "Supervisory Patent Examiner". Accordingly, the new ground of rejection in this Answer is unauthorized; its a nullity as far as you are concerned. Therefore, you should ignore it, consider only the authorized rejection appealed from, and reverse for the reasons in the appeal brief. In which case, you need read no further.

Assuming arguendo you do not reverse based upon the FOA and the appeal brief, then:

First, you should recognize that the original basis for rejection has been abandoned. Specifically, the original basis for rejection required modification of Holmes to include a watermark. That motivation is gone, since the examiners now assert that Holmes includes a watermark.

Second, the examiner's new argument is defective.

Answer page 3 lines 10-16 argue that Houser suggests making Holmes data object,

alleged in the Answer to be a watermark, a difficult to forge watermark, by applying Houser's process of watermarking. This argument presupposes that Holmes "watermark" (aka data object) is not difficult to forge. However, to forge a watermark seems to require removing the original watermark and replacing it with a new (forged) watermark. That requires removing the original watermark. The examiner's argument only makes sense if the original watermark in Holmes is NOT difficult to remove. The applicant has consistently stated that "A watermark in this art refers to information embedded into a digital signal in a way that is difficult to remove" and that is consistent with Houser. Cf. appeal brief page 26. So the examiner's rejection relying upon Houser implies that Holmes does not disclose a watermark. This is because the examiner's proposed modification of Holmes requires removing Holmes data objection, which implies that Holmes' data object is not difficult to remove. That Holmes data object is easily removed is explained by Holmes. Holmes explains that "This portion 14 will be common to all copied files, and enables the data in block 8 which identifies the copied file to be located." Holmes col. 3 lines 59-63.

In any case, all of the other reasons stated in the appeal brief why the rejections of claims over Holmes and Houser are still accurate, regardless whether the Board deems Holmes data object to be a watermark.

Answer page 3 lines 15 et seq refer to the argument on pages 30-31 of the appeal brief. ("On pages 30-31 of appellant's brief, appellant argues..."). That statement is incorrect. The appeal brief at pages 30-31 are part of a quote from the response the applicant filed 7-1-2011. See the appeal brief page 29 last line to page 30 line 1. The appeal brief arguments directly addressing the claims begin on page 59. It appears from this statement indicating a misreading of

the Brief, and lack of response to any of the claim by claim arguments on the many and varied limitations, that the examiners failed to actually review the entire brief.

In any case, Answer page 4 states that:

Holmes explicitly teaches the embedding of ownership identification data/code in software. In Fig. 1 and Col 3, Lines 39 thru Col 4, Line 2, Holmes teaches embedding identification data/code in software wherein the identification data uniquely identifies an authorized user (license code). In light of this disclosure and the explanation, Holmes "embedded unique identification data/code" serves as the license code recited in appellant's claims. The argument with respect to independent claims 52,59,62 and 63 is based on the argument with respect to independent claim 32 and the same response presented above applies to the argument.

Appellants reply is that, for all rejected claims, there is no motivation to modify Holmes, as noted in the appeal brief.

ALL OF THE OTHER ARGUMENTS IN THE BRIEF STAND UNCONTROVERTED

As noted above, the examiners failed to directly address most of the claims. However, they also failed to address claims containing limitations clearly distinct from what they did expressly address, and they failed to respond to the appellants arguments on those claims. For example, claim 61 defines the concept of " encoding said first code resource to form an encoded

first code resource" and the "code resource" is definite and well defined in our specification. See appeal brief pages 11 and 12 (citation to support) and pages 99 and 100. Claim 62 similarly recites that code interrelationships are encoded, using a license key. This paragraph is merely illustrative that the Answer, as did the final rejection, failed to address all of the claim limitations. A systematic review of the limitations identified in the appeal brief, and not addressed in the Answer, follows.

Regarding claim 35 and 36, the Answer fails to explain how the proposed combination results in the limitation that "watermark is accessible with a key," that is identification of the watermark bits. See appeal brief page 75-79.

Regarding claim 36, the Answer fails to explain how the proposed combination suggests "wherein said key enables said first license code encoded watermarked software to provide said specified functionality," thereby linking the same key to both the watermark access and functionality enablement. See the appeal brief pages 79-81.

Regarding claim 37, the Answer fails to explain how the proposed combination suggests "wherein said first license code encoded watermarked software is configured to determine said key from said personalization information," which information includes the license code. See the appeal brief pages 81-82.

Regarding claim 38, the Answer fails to explain how the proposed combination suggests "wherein the step of embedding the software with a watermark is performed during execution of the software." See the appeal brief pages 82-83.

Regarding claim 40, the Answer fails to explain how the proposed combination suggests, as explained at appeal brief pages 83-84 "using said licensing information in an algorithm to

identify a watermark in said software."

Regarding claim 41, the Answer fails to explain how the proposed combination suggests, as explained at appeal brief pages 84-86, a "watermark encodes therein information defining an executable code providing a functionality of said software."

Regarding claim 42, the Answer fails to explain how the proposed combination provides, as explained at appeal brief pages 84-86, "wherein the watermark affects functionality of the watermarked software."

Regarding claim 43, the Answer fails to explain how the proposed combination suggests, as explained at appeal brief pages 86-88, the "instructions adapted to be executed by a processor of a computer system" ... "comprise decode instructions for said computer system to use said information to generate a decode key for decoding said software."

Regarding claim 44, the Answer fails to explain how the proposed combination suggests, as explained at appeal brief pages 89, "wherein said identifying information comprises a license key, and said decode instructions instruct said computer to determine said license key from said information and to generate said decode key using said license key".

Regarding claim 53, the Answer fails to explain, as explained at appeal brief page 92, how the proposed combination suggests a system configured to embed a watermark storing a licence code.

Regarding claim 55, the Answer fails to explain, as explained at appeal brief pages 93-94, how the proposed combination suggests "first license code is fixed prior to distribution of the software."

Regarding claim 58, the Answer fails to explain, as explained at appeal brief pages

95-96, how the proposed combination provides "said software product using license information entered via said input in response to said prompt in a routine designed to decode a first license code encoded in said software."

Regarding claim 60, the Answer fails to explain, as explained at appeal brief pages 97-99, how the proposed combination suggests "when installed on a computer system, said first license key encoded software code will provide said specified underlying functionality only after receipt of said first license key."

Regarding claim 61, the Answer fails to explain, as explained at appeal brief pages 99-100, how the proposed combination suggests modifying the software by "encoding said first code resource to form an encoded first code resource"; including in the software the "encoded first code resource, and a decode resource for decoding said encoded first code resource;" where "decode resource is configured to decode said encoded first code resource"; and wherein that decoding occurs "upon receipt of said first license key."

Regarding claim 62, the Answer fails to explain, as explained at appeal brief pages 99-104, how the proposed combination suggests modifying the software by "encoding, by said computer using at least a first license key and an encoding algorithm, said software code, to form a first license key encoded software code in which at least one of said software code interrelationships are encoded."

Regarding claim 64, the Answer fails to explain, as explained at appeal brief pages 104-105, how the proposed combination suggests modifying the software by individually encoding each instance of software with a different license code.

SIGNATURE:

/RichardNeifeld/

RICHARD NEIFELD, REGISTRATION NO 35,299
ATTORNEY OF RECORD

RAN

Date/time: May 12, 2012 (1:22pm)

Y:\Clients\SCOT Scott A Moskowitz and Wistaria Trading,
Inc\SCOT0014-4\Drafts\ReplyBrief_SCOT0014-4_8-9-2012.wpd

Electronic Acknowledgement Receipt

EFS ID:	13481338
Application Number:	11895388
International Application Number:	
Confirmation Number:	2103
Title of Invention:	Data protection method and device
First Named Inventor/Applicant Name:	Scott A. Moskowitz
Customer Number:	31518
Filer:	Richard A. Neifeld
Filer Authorized By:	
Attorney Docket Number:	SCOT0014-4
Receipt Date:	13-AUG-2012
Filing Date:	24-AUG-2007
Time Stamp:	14:47:39
Application Type:	Utility under 35 USC 111(a)

Payment information:

Submitted with Payment	no
------------------------	----

File Listing:

Document Number	Document Description	File Name	File Size(Bytes)/ Message Digest	Multi Part /.zip	Pages (if appl.)
1	Reply Brief Filed	ReplyBrief_SCOT0014-4_8-9-2012.pdf	62213 <small>dae88628e66946091e3b829ecca4f5760872af84</small>	no	9

Warnings:

Information:

This Acknowledgement Receipt evidences receipt on the noted date by the USPTO of the indicated documents, characterized by the applicant, and including page counts, where applicable. It serves as evidence of receipt similar to a Post Card, as described in MPEP 503.

New Applications Under 35 U.S.C. 111

If a new application is being filed and the application includes the necessary components for a filing date (see 37 CFR 1.53(b)-(d) and MPEP 506), a Filing Receipt (37 CFR 1.54) will be issued in due course and the date shown on this Acknowledgement Receipt will establish the filing date of the application.

National Stage of an International Application under 35 U.S.C. 371

If a timely submission to enter the national stage of an international application is compliant with the conditions of 35 U.S.C. 371 and other applicable requirements a Form PCT/DO/EO/903 indicating acceptance of the application as a national stage submission under 35 U.S.C. 371 will be issued in addition to the Filing Receipt, in due course.

New International Application Filed with the USPTO as a Receiving Office

If a new international application is being filed and the international application includes the necessary components for an international filing date (see PCT Article 11 and MPEP 1810), a Notification of the International Application Number and of the International Filing Date (Form PCT/RO/105) will be issued in due course, subject to prescriptions concerning national security, and the date shown on this Acknowledgement Receipt will establish the international filing date of the application.



UNITED STATES PATENT AND TRADEMARK OFFICE

UNITED STATES DEPARTMENT OF COMMERCE
United States Patent and Trademark Office
Address: COMMISSIONER FOR PATENTS
P.O. Box 1450
Alexandria, Virginia 22313-1450
www.uspto.gov

Table with 5 columns: APPLICATION NO., FILING DATE, FIRST NAMED INVENTOR, ATTORNEY DOCKET NO., CONFIRMATION NO.
11/895,388 08/24/2007 Scott A. Moskowitz SCOT0014-4 2103

31518 7590 09/05/2012
NEIFELD IP LAW, PC
4813-B EISENHOWER AVENUE
ALEXANDRIA, VA 22304

EXAMINER

OKEKE, IZUNNA

ART UNIT PAPER NUMBER

2432

NOTIFICATION DATE DELIVERY MODE

09/05/2012

ELECTRONIC

Please find below and/or attached an Office communication concerning this application or proceeding.

The time period for reply, if any, is set in the attached communication.

Notice of the Office communication was sent electronically on above-indicated "Notification Date" to the following e-mail address(es):

general@neifeld.com
rneifeld@neifeld.com
rhahl@neifeld.com



United States Patent and Trademark Office

**Under Secretary of Commerce for Intellectual Property and
Director of the United States Patent and Trademark Office**
P.O. Box 1450
Alexandria, Virginia 22313-1450
www.uspto.gov

NEIFELD IP LAW, PC
4813-B EISENHOWER AVENUE
ALEXANDRIA, VA 22304

Appeal No: 2012-011854
Application: 11/895,388
Appellant: Scott A. Moskowitz

**Board of Patent Appeals and Interferences
Docketing Notice**

Application 11/895,388 was received from the Technology Center at the Board on August 27, 2012 and has been assigned Appeal No: 2012-011854.

In all future communications regarding this appeal, please include both the application number and the appeal number.

The mailing address for the Board is:

BOARD OF PATENT APPEALS AND INTERFERENCES
UNITED STATES PATENT AND TRADEMARK OFFICE
P.O. BOX 1450
ALEXANDRIA, VIRGINIA 22313-1450

The facsimile number of the Board is 571-273-0052. Because of the heightened security in the Washington D.C. area, facsimile communications are recommended. Telephone inquiries can be made by calling 571-272-9797 and referencing the appeal number listed above.

By order of the Board of Patent Appeals and Interferences.



UNITED STATES PATENT AND TRADEMARK OFFICE

UNITED STATES DEPARTMENT OF COMMERCE
United States Patent and Trademark Office
Address: COMMISSIONER FOR PATENTS
P.O. Box 1450
Alexandria, Virginia 22313-1450
www.uspto.gov

APPLICATION NO.	FILING DATE	FIRST NAMED INVENTOR	ATTORNEY DOCKET NO.	CONFIRMATION NO.
11/895,388	08/24/2007	Scott A. Moskowitz	SCOT0014-4	2103
31518	7590	03/12/2015	EXAMINER	
NEIFELD IP LAW, PC 4813-B EISENHOWER AVENUE ALEXANDRIA, VA 22304			OKEKE, IZUNNA	
			ART UNIT	PAPER NUMBER
			2432	
			NOTIFICATION DATE	DELIVERY MODE
			03/12/2015	ELECTRONIC

Please find below and/or attached an Office communication concerning this application or proceeding.

The time period for reply, if any, is set in the attached communication.

Notice of the Office communication was sent electronically on above-indicated "Notification Date" to the following e-mail address(es):

general@neifeld.com
rneifeld@neifeld.com
rhahl@neifeld.com

UNITED STATES PATENT AND TRADEMARK OFFICE

BEFORE THE PATENT TRIAL AND APPEAL BOARD

Ex parte SCOTT A. MOSKOWITZ

Appeal 2012-011854
Application 11/895,388
Technology Center 2400

Before MAHSHID D. SAADAT, JASON V. MORGAN, and
JAMES W. DEJMEK, *Administrative Patent Judges*.

DEJMEK, *Administrative Patent Judge*.

DECISION ON APPEAL

Appellant appeals under 35 U.S.C. § 134(a) from a rejection of claims 32, 33, 35–44, 52, 53, 55–57, and 59–64. Claims 1–31 and 46–51 are canceled. Claims 34, 45, 54, and 58 are objected to, but are otherwise indicated as being allowable if rewritten in independent form with all parent claim recitations. Ans. 2. We have jurisdiction over the pending claims under 35 U.S.C. § 6(b).

We AFFIRM-IN-PART.

STATEMENT OF THE CASE

Introduction

Appellant's invention is related to the protection of digital information. Spec. ¶ 2. As claimed, the digital information relates to software designed to provide a specified functionality. *See generally* Claims 32–45 and 52–64. The software is protected by embedding a watermark within it. Spec. ¶ 13. The watermark may include license code information for the software. *Id.*

Representative claims 32 and 40 are illustrative of the subject matter on appeal and are reproduced below with the disputed limitations emphasized in *italics*:

32. A computer-based method for modifying software, comprising:

receiving, in a computer having a processor and memory, software, wherein said software provides a specified functionality;

embedding a watermark into said software, using said computer, said watermark encoding at least one first license code, thereby resulting in a first license code encoded watermarked software.

40. An article of manufacture comprising a machine readable medium, having thereon stored instructions adapted to be executed by a processor of a computer system, said computer system including a memory, which instructions when executed by said computer system result in a process comprising:

said computer system storing a software in said memory;

said computer system receiving licensing information as an input and using said licensing information in an algorithm to *identify* a watermark in said software.

References

The prior art relied upon by the Examiner in rejecting the claims on appeal is:

Holmes	US 5,287,407	Feb. 15, 1994
Houser et al. (hereinafter "Houser")	US 5,606,609	Feb. 25, 1997

The Examiner's Rejections¹

Claims 32, 33, 35–44, 52, 53, 55–57, and 59–64 stand rejected under 35 U.S.C. § 103(a) as being unpatentable over Holmes and Houser. Final Act. 4–8.

¹ The Examiner has withdrawn the rejections of claims 34, 45, 54, and 58. Ans. 2.

ANALYSIS²

Rejections under 35 U.S.C. § 103(a)

Claims 32, 33, 39, 52, 53, 56, 57, 59, 63, and 64

In relevant part, claim 32 requires the step of “embedding a watermark into [the] software, . . . [the] watermark encoding at least one first license code” Claim 32. Appellant contends the “unique identifying data” of Holmes does not equate to a license code for the software. App. Br. 60–65. Appellant concedes Houser teaches or suggests embedding a watermark in a document (*id.* at 65–66) but contends Houser’s teaching does not extend to software programs. *Id.* at 65–72. Appellant concludes “[n]either [Holmes nor Houser] discloses a watermark encoding a license code embedded software.” *Id.* at 72.

In response, the Examiner finds “Holmes teaches a software protection method wherein unique identifying data is embedded into software.” Ans. 3. The Examiner interprets the unique identifying data as the claimed license code. *Id.* Further, the Examiner finds Houser teaches a “watermark being used to embed information in software such as a file or video data.” *Id.* The Examiner concludes “[i]t would be obvious to one of ordinary skill that the identification information (license code) embedded in the software as taught by Holmes is embedded using a watermarking process to make it difficult for the data to be identified or removed [as taught in Houser].” *Id.*

² Throughout this opinion we refer to the Appeal Brief filed May 14, 2012, the Reply Brief filed August 13, 2012, the Examiner’s Answer mailed on August 8, 2012, and the Final Office Action (“Final Act.”) having a notification date of September 20, 2011.

We agree with the Examiner’s findings and conclusions. Holmes’ invention relates to software protection and, in particular, “combating the making of unauthorized copies of software.” Holmes, col. 1, ll. 8–9. To accomplish this objective, Holmes teaches the inclusion of a predetermined block of data that is included within a master file of software. *Id.*, at col. 3, ll. 38–46. Information contained in this block (which “contains a predetermined sequence of code”) includes unique information related to the file. *Id.* at col. 3, ll. 45, 56–58. Holmes teaches this information “may comprise the name of the authorized user” for the file. *Id.* at col. 3, ll. 58–59. Such information is consistent with license codes as disclosed in the Specification. *See* Spec. ¶ 13 (describing keys being derived from “license codes or other ownership identification information.”). We therefore concur with the Examiner that under the broadest reasonable interpretation of “license code,” as recited in claim 32, Holmes teaches a license code being embedded into software. Ans. 3.

We are unpersuaded by Appellant’s argument that “Holmes and Houser are not compatible, and the modification of Holmes in view of Houser proposed by the examiner is improper.” App. Br. 72. Holmes teaches positioning the data block containing the license code “anywhere within the master and copied files . . . [to make it] difficult for an unauthorized copier to identify and remove the data.” Holmes, col. 4, ll. 1–4. Houser teaches a watermark that is “difficult-to-forge.” Houser, col. 16, l. 61. We agree with the Examiner that it would have been obvious to an artisan having ordinary skill in the art to combine the “difficult-to-forge” watermark of Houser with the embedded license code of Holmes to make it difficult to identify and remove the data. Ans. 3.

Additionally, in the Reply Brief, Appellant argues “[t]he rejection in the Answer is not the rejection in the final office action.” Reply Br. 2. Appellant contends the Examiner changed positions as to whether Holmes teaches a watermark. *Id.* at 2–3. We are unpersuaded the Examiner has set forth a new grounds of rejection. Based on the same findings as in the final office action, the Examiner, in the Answer, the Examiner, responds to and addresses arguments raised by Appellants. Further, we note the issue raised by Appellants relates to petitionable subject matter and is not for this panel to address. *See* 37 C.F.R. § 41.40(a) (“Any request to seek review of the primary examiner's failure to designate a rejection as a new ground of rejection in an examiner's answer must be by way of a petition to the Director”).

For the reasons described *supra*, we are unpersuaded of Examiner error and therefore sustain the rejection of claim 32. For similar reasons, we sustain the rejection of claims 52, 53, 59, 63, and 64 as these claims are similar in scope to claim 32. *See* App. Br. 91, 97, and 105. Separate patentability is not argued for claims 33 and 39, which depend from claim 32, or for claims 56 and 57, which depend from claim 52. For similar reasons, we sustain the rejection of claims 33, 39, 56, and 57.

Claim 35

Appellant argues claim 35 “relate[s] to the linking of the watermark encoded first license code with accessing the specified functionality, of the modified software.” App. Br. 75. We disagree the claim is so narrow. The language of the claim recites: The process of claim 32, wherein said watermark is accessible with a key. Appellant contends the disclosure of

Appeal 2012-011854
Application 11/895,388

Houser relied upon by the Examiner is “for a different concept, public/private key encryption” and is different than the key which accesses the watermark of claim 35. App. Br. 77. We are unpersuaded of Examiner error. As identified by the Examiner, Houser teaches “a private key and/or a public key pair may be entered by the user to encrypt information stored with the electronic document security application and/or information embedded into an electronic document [i.e., the watermark].” Houser, col. 9, ll. 37–40; Final Act. 5; *see also* App Br. 65–71 (acknowledging Houser’s teaching of a watermark). Houser further teaches a password, which may be equivalent to the private key “serves to prevent unauthorized access to the various features of the electronic document security application, such as the signature insertion module **240**.” Houser, col. 9, ll. 30–41. Accordingly, we sustain the Examiner’s rejection of claim 35.

Claims 36 and 60

Claims 36 and 60 include limitations that require the underlying software functionality be enabled upon the presence or detection of a key, or other software code. *See, e.g.*, Claim 60 (“software code will provide said specified underlying functionality only after receipt of said first license key”). Appellant argues neither Holmes nor Houser teaches or suggests enabling software functionality based on a license key. App. Br. 80, 98. We agree. Holmes states the data block containing the identification information “does not play any part in the function of the software of the master file itself.” Holmes, col. 3, ll. 41–42. Accordingly, we cannot sustain the rejection of claims 36 and 60.

Claim 37

Appellant characterizes claim 37 as defining “a modified software having a watermark encoding a first license code which is configured to determine a key from inter alia the license code. App. Br. 82. Appellant argues “Holmes and Houser are silent regarding license codes and therefore do not suggest claim 37’s configuration.” *Id.* As discussed *supra*, we concur with the Examiner’s finding that Holmes teaches a license code. Accordingly, we are unpersuaded of Examiner error and sustain the rejection of claim 37.³

Claim 38

Claim 38 depends from claim 32 and adds the limitation “wherein the step of embedding the software with a watermark is performed during execution of the software.” Claim 38. Appellant contends the support identified by the Examiner is unrelated to this limitation. App. Br. 83. We agree. In the Final Office Action, the Examiner relies on Holmes (col. 3, ll. 38–46) as teaching this limitation. Final Act. 6. The cited passage of Holmes relates to block of data located within the master file that contains the unique identifying data. Holmes, col. 3, ll. 38–46. The Examiner has not shown how this section addresses when the embedding of the data block occurs relative to execution of the software. Accordingly, we cannot sustain the rejection of claim 38.

³ We note there is no antecedent basis for “said personalization information” of claim 37, which depends from claim 35. We recommend the Examiner ascertain whether a rejection under 35 U.S.C. § 112 ¶ 2 is appropriate.

Claims 40–44

Independent claim 40 requires using input “licensing information in an algorithm *to identify* a watermark in said software.” Claim 40 (emphasis added). Appellant argues “[n]either Holmes nor Houser disclose using received licensing information to identify a watermark in software.” App. Br. 84. Appellant further argues the Examiner fails to adequately explain how the references disclose this limitation. *Id.*

In rejecting claim 40, the Examiner relies on the same reasoning as set forth in the rejection of claim 32. Final Act. 4. No additional support is set forth in the Answer.

Claim 40 differs in scope from claim 32. *Inter alia*, claim 40 requires the use of licensing information to identify a watermark in the software. This limitation is not present in claim 32. On the record before us, we agree with Appellant that the Examiner has not demonstrated how this limitation is taught or suggested by the identified references. Accordingly, we cannot sustain the rejection of claim 40 or the rejection of claims 41–44 which depend therefrom.

Claim 55

Appellant argues “nothing in Houser and Holmes suggest [a first license code is fixed prior to distribution of the software],” as recited in claim 55. App. Br. 94. We disagree. The Examiner identified, *inter alia*, a section of Holmes wherein the unique identification information (i.e., license code) is incorporated into the copied version of the software. *See* Holmes, col. 3, l. 38–col. 4, l. 45; Final Act. 4. Holmes further teaches a series of steps in implementing his invention wherein the fourth step includes

Appeal 2012-011854
Application 11/895,388

releasing the copied file for use. Holmes, col. 4, ll. 21–32. Accordingly, the rejection of claim 55 is sustained.

Claim 61

Appellant contends the Examiner’s rejection of claim 61 does not address various limitations of the claim, such as “encoding said first code resource to form an encoded first code resource,” or an “encoded first code resource, and a decode resource for decoding said encoded first code resource” in the software. App. Br. 99–100. The Examiner relies on reasoning found in the rejections of claims 32 and 43. Final Act. 7. The Examiner’s findings do not support the combination of Houser and Holmes teaches or suggests a modified software code comprising an encoded first code resource and a decode resource for decoding the encoded first code resource, wherein the decode resource is configured to decode the encoded first code resource upon receipt of a first license key. Accordingly, we do not sustain the rejection of claim 61.

Claim 62

Appellant argues “neither Holmes nor Houser disclose or suggest encoding code interrelationships between code resources of the software.” App. Br. 103–04. The Examiner bases the rejection of claim 62 on the reasons set forth in rejecting claims 32 and 61. Final Act. 8. We disagree the same reasons apply. For example, claims 32 and 61 do not recite limitations regarding “software code interrelationships between code resources that result in a specified underlying functionality.” Because the

Appeal 2012-011854
Application 11/895,388

Examiner has not shown how the references teach or suggest all the limitations of claim 62, we do not sustain its rejection.

DECISION

The rejection of claims 32, 33, 35, 37, 39, 52, 53, 55–57, 59, and 63–64 under 35 U.S.C. § 103(a) is affirmed.

The rejection of claims 36, 38, 40–44, and 60–62 under 35 U.S.C. § 103(a) is reversed.

No time period for taking any subsequent action in connection with this appeal may be extended under 37 C.F.R. § 1.136(a)(1)(iv).

AFFIRMED-IN-PART

kis

NEIFELD REF: SCOT0014-4
CLIENT REF: SCOT0014-4
Application/Patent No: 11/895,388
USPTO CONF. NO: 2103
Inventor: MOSKOWITZ, Scott
Title: DATA PROTECTION METHOD AND DEVICE
Examiner/ArtUnit: OKEKE, Izunna/2432
ENTITY STATUS: SMALL
Priority claims and PCT Intl data:
Application 11/895,388 is a Division of 10/602,777 filed 6-25-2003 patented 7,664,263
Application 10/602,77 is a Continuation of 09/046,627 filed 3-24-1998 patented 6,598,162
Application 09/046,627 is a Continuation in Part of 08/587,943 filed 1-17-1996 patented 5,745,569

37 CFR 1.97 INFORMATION DISCLOSURE STATEMENT

This application is:
___ within 3 months of the US or 371 national stage filing date;
___ before first action on the merits (no fee required);
XXX after first action on the merits and before final action (1.17(P) fee required);
___ after final action;
___ after notice of allowance and before payment of the issue fee; or
___ after payment of the issue fee.

XXX The applicant is paying herewith the fee for obtaining consideration of an IDS filed after a first action on the merits.

IDENTIFICATION OF REFERENCES CITED IN APPLICATIONS TO WHICH 11/895,388
CLAIMS CONTINUING STATUS

REGARDING CITED REFERENCES

This IDS is an attempt to compile all references previously cited in Scott Moskowitz's cases. Upon compilation, some of the reference citations were vague, and some were to filed patent applications instead of published documents. This IDS attempts to account for each item to provide all citations to the examiner.

References previously cited and considered by the examiner in application 11/895,388(SCOT0014-4) are identified by placement of an "X" in the far right column.

CITED US PATENTS AND US PATENT APPLICATION PUBLICATIONS

Most pending Scott Moskowitz cases claim 35 USC 120 priority to prior cases containing a large number of cited US patents and published US applications. The citations list herein should incorporate all of those documents and may incorporate any additional documents found in other patent applications in patent families not linked by 35 USC 120 to this application. Since no US patent or US published applications need to be filed in order for the examiner to

consider citations thereto; the applicant may attempt to correlate the US patents and publications cited herein to those already of record due to citations in applications to which this application claims priority, if the examiner so requests.

FOREIGN PATENT REFERENCES

The IDS cites foreign patent references identified herewith as F001- F029 .

The table below identifies F references cited in this application or an application to which this application claims 35 USC 120 priority.

DOCKET NO	APPLICATION NUMBER	CITED F REFERENCES
SCOT0014-4	11/895,388	F01-F029

Accordingly, the following F references are not yet of record and are submitted herewith: n/a

NON PATENT LITERATURE REFERENCES

The IDS cites foreign patent references identified herewith as L001- L256.

The table below identifies L references cited in this application or in an application to which this application claims 35 USC 120 priority.

DOCKET NO	APPLICATION NUMBER	CITED L REFERENCES
SCOT0014-4	11/895,388	L1-L212
	L reference citations of patent applications as filed for which a subsequent publication of the application is identified and cited herein.	L01-L35; L185-L200; L202
	L reference citation numbers that have no associated citation; original citation was a duplicate of some other citation.	L98, L100, L102; L103; L106-L114; L116-L154

References previously cited, applications for which a subsequent publication is cited, and reference numbers having no associated reference: L1-L212

Accordingly, the following L references are not yet of record and are submitted herewith: L213-L256

MASTER LIST OF RELATED CASES IN WHICH THE SAME INFORMATION MAY BE
CITED

DOCKET REFERENCE	APPLICATION	FILING DATE	DATE CASE ADDED TO THIS MASTER LIST OF RELATED CASES
SCOT0010-4	11/599,838	11/15/2006	10/15/2010 JRE
SCOT0010-5	11/899,662	9/7/2007	10/15/2010 JRE
SCOT0010-6	10/369,344	2/18/2003	08/1/2011 JRE
SCOT0010-7	11/482,654	7/7/2006	08/1/2011 JRE
SCOT0010-8	12/215,812	6/30/2008	10/15/2010 JRE
SCOT0010-10	12/901,568	10/10/2010	11/4/2010 JRE
SCOT0010-11	11/497,822	8/2/2006	08/1/2011 JRE
SCOT0010-12	12/217,834	7/9/2008	11/8/2010 JRE
SCOT0010-13	11/897,790	8/31/2007	08/1/2011 JRE
SCOT0010-14	12/462,799	8/10/2009	12/15/2010 JRE
SCOT0010-16	11/899,661	9/7/2007	08/1/2011 JRE
SCOT0010-17	12/590,681	11/19/2009	12/15/2010 JRE
SCOT0010-18	11/897,791	8/31/2007	08/1/2011 JRE
SCOT0010-19	12/590,553	11/10/2009	08/1/2011 JRE
SCOT0010-20	12/592,331	11/23/2009	08/1/2011 JRE
SCOT0010-21	11/599,964	11/15/2006	08/1/2011 JRE
SCOT0010-22	13/212,264	8/18/2011	1/11/2012 JRE
SCOT0011-1	08/674,726	7/2/1996	08/1/2011 JRE
SCOT0011-2	09/545,589	4/7/2000	1/11/2012 JRE
SCOT0011-3	11/244,213	10/5/2005	1/11/2012 JRE
SCOT0011-4	12/009,914	1/23/2008	10/15/2010 JRE
SCOT0011-5	12/005,230	12/26/2007	10/15/2010 JRE
SCOT0011-6	12/803,168	6/21/2010	10/15/2010 JRE
SCOT0011-7	11/649,026	1/3/2007	08/1/2011 JRE
SCOT0011-8	12/803,194	06/21/2010	10/15/2010 JRE
SCOT0011-9	12/892,900	9/28/2010	11/8/2010 JRE

DOCKET REFERENCE	APPLICATION	FILING DATE	DATE CASE ADDED TO THIS MASTER LIST OF RELATED CASES
SCOT0012-1	08/489,172	6/7/1995	08/1/2011 JRE
SCOT0012-2	08/775,216	12/31/1996	01/11/2011 JRE
SCOT0012-3	08/999,766	7/23/1997	10/15/2010 JRE
SCOT0012-4	11/894,476	8/21/2007	10/15/2010 JRE
SCOT0012-5	11/050,779	2/7/2005	10/15/2010 JRE
SCOT0012-6	12/802,519	6/8/2010	11/4/2010 JRE
SCOT0012-7	12/383,916	3/30/2009	10/15/2010 JRE
SCOT0012-8	11/894,443	8/21/2007	10/15/2010 JRE
SCOT0012-9	12/913,751	10/27/2010	11/8/2010 JRE
SCOT0012-10	13/803,889	3/14/2013	4/16/2013 JRE
SCOT0013-1	08/587,943	1/17/1996	1/11/2012 JRE
SCOT0014-1	09/046,627	3/24/1998	1/11/2012 JRE
SCOT0014-2	10/602,777	6/25/2003	08/1/2011 JRE
SCOT0014-3 redocketed as SCOT0020-2	11/512,701	8/29/2006	10/15/2010 JRE
SCOT0014-4	11/895,388	8/24/2007	10/15/2010 JRE
SCOT0014-5	12/655,002	12/22/2009	08/1/2011 JRE
SCOT0014-6	13/556,420	7/24/2012	9/17/2012 JRE
SCOT0014-7	13/794,584	3/12/2013	4/16/2013 JRE
SCOT0015-1	09/731,039	12/7/2000	1/11/2012 JRE
SCOT0015-2	11/647/861	12/29/2006	1/11/2012 JRE
SCOT0015-3	12/383,879	3/30/2009	10/15/2010 JRE
SCOT0015-4	12/886,732	9/21/2010	10/15/2010 JRE
SCOT0015-5	13/572,641	8/11/2012	10/11/2012 JRE
SCOT0015-6	13/794,742	3/12/2013	4/16/2013 JRE
SCOT0016-1	10/049,101	7/23/2002	1/11/2012 JRE
SCOT0016-2	12/287,443	10/9/2008	10/15/2010 JRE
SCOT0016-3	13/413,691	3/7/2012	8/30/2012 JRE
SCOT0016-4	13/796,538	3/12/2013	4/16/2013 JRE
SCOT0017-1	09.657,181	9/7/2000	1/11/2012 JRE

DOCKET REFERENCE	APPLICATION	FILING DATE	DATE CASE ADDED TO THIS MASTER LIST OF RELATED CASES
SCOT0017-2	12/005,229	12/26/2007	1/11/2012 JRE
SCOT0017-3	12/655,357	12/22/2009	10/15/2010 JRE
SCOT0017-4	13/035,964	2/26/2011	08/1/2011 JRE
SCOT0017-5	13/487,119	6/1/2012	4/16/2013 JRE
SCOT0017-6	13/802,384	3/13/2013	4/16/2013 JRE
SCOT0018-1	10/417/231	4/17/2003	01/11/2011 JRE
SCOT0018-2	11/900,065	9/10/2007	10/15/2010 JRE
SCOT0018-3	11/900,066	9/10/2007	1/11/2012 JRE
SCOT0018-4	12/383,289	3/23/2009	08/1/2011 JRE
SCOT0018-5	13/273,930	10/14/2011	1/11/2012 JRE
SCOT0018-6	13/551,097	7/17/2012	4/16/2013 JRE
SCOT0018-7	13/488,357	6/4/2012	9/9/2012 JRE
SCOT0018-8	13/488,395	6/4/2012	9/9/2012 JRE
SCOT0019-1	09/053,628	4/2/1998	1/11/2012 JRE
SCOT0019-2	09/644,098	8/23/2000	1/11/2012 JRE
SCOT0019-3	11/358,874	2/21/2006	1/11/2012 JRE
SCOT0019-4	12/799,894	5/4/2010	12/13/2010 JRE
SCOT0020-1	09/731,040	12/7/2000	1/11/2012 JRE
SCOT0020-2	11/512,701	8/29/2006	08/1/2011 JRE
SCOT0020-3	13/826,858	3/14/2013	4/16/2013 JRE
SCOT0020-4	13/797,744	3/12/2013	4/16/2013 JRE
SCOT0022-1	09/594,719	6/16/2000	4/16/2013 JRE
SCOT0022-2	11/519,467	9/12/2006	4/16/2013 JRE
SCOT0022-3	12/655,036	12/22/2009	08/1/2011 JRE
SCOT0022-4	13/423,650	3/19/2012	7/26/2012 JRE
SCOT0022-5	13/802,471	3/13/2013	4/16/2013 JRE
SCOT0023-1	08/772,222	12/20/1996	4/16/2013 JRE
SCOT0023-2	09/456,319	12/8/1999	4/16/2013 JRE
SCOT0023-3	11/826,234	12/30/2004	4/16/2013 JRE
SCOT0023-4	11/592,879	11/2/2006	4/16/2013 JRE

DOCKET REFERENCE	APPLICATION	FILING DATE	DATE CASE ADDED TO THIS MASTER LIST OF RELATED CASES
SCOT0023-5	12/798,959	4/14/2010	08/1/2011 JRE
SCOT0024-2	11/518,806	9/11/2006	08/1/2011 JRE
SCOT0024-3	13/429,396	3/25/2012	7/26/2012 JRE
SCOT0025-1	61/794,141	3/15/2013	4/16/2013JRE

AS OF 1/12/2012, THE FOLLOWING TABLE COLLATES ADDITIONAL REFERENCES
CITED IN ANY SCOT (SCOTT MOSKOWITZ) CASE

Date of Document Citing Reference	Atty Ref	Application Number	ID of paper in which references were cited	References checked to see if they existed in the master IDS (initials of person checking)	Reference Identifiers of New references in document, now added to master IDS
Sept 14, 2010	SCOT0 012-7	12/383,916	892	JRE	U#299
11/17/2010	ALL	N/A	Review of draft master IDS, correction to cite publications in lieu of filed applications, per RAN instructions.	JRE	P76-P82
12/9/2010	SCOT0 018-2	11/900,065	892	JRE	U303 & P83
11/30/2010	SCOT0 019-4	12/799,894	892	JRE	U304
11/21/2011	SCOT0 016-2	12/287,443	892	JRE	U305, U306 & U307
1/12/2012	SCOT0 011-8	12/803,194	892	JRE	U308
1/12/2012	SCOT0 014-5	12/655,002	892	JRE	U309
1/12/2012	SCOT0 017-4	13/035,964	892	JRE	U310-U316
1/12/2012	SCOT0 018-2	11/900,065	892	JRE	P84-P85
3/7/2012	SCOT0 018-2	11/900,065	892	JRE	P86 -P87 & U317
8/30/2012	SCOT0 016-3	13/413,691	892	JRE	U318 & U319

9/17/2012	SCOT0014-6	13/556,420	Per RAN created CTS reminder	JRE	L212
11/26/2012	SCOT0017-4	13/035,964	Per RAN inst rec'vd 11/15/2012	JRE	U320 & L213-L217
4/16/2013	SCOT0017-4	13/035,964	Review of Patented case	JRE	U322-U326 & P88-P90
6/13/2013	SCOT0018-7	13/488,357	Per instructions received from RAN	JRE	U329-332 L218-L223
6/28/2013	SCOT0014-6	13/556,420	Per instructions received from RAN	JRE	U0333
1/21/2014			Per Instructions received from RAN on 1/7/2014	JRE	L229
2/6/2014	SCOT0017-6	13/802,384	Per instructions received from RAN on 1/30/2014	JRE	U335
4/7/2014			Per Instructions received from RAN on 4/7/2014	JRE	L231-L232
5/15/2014	SCOT0020-3	13/826,858	892 issued 4/21/2014	JRE	U379-U384
8/18/2014	SCOT0020-3	13/826,858	892 issued 8/18/2014	JRE	U385-U388
9/12/2014			Per Instructions received from RAN 9/12/2014	JRE	U389-393

10/13/2014			Per instructions received from RAN on 10/10/2014	JRE	U394-U398 and P98
10/17/2014			Per instructions received from BTM 10/17/2014	JRE	L233-L234
10/17/2014			Per instructions received from RAN (client sent references)	JRE	L235-L236
11/6/2014	SCOT0016-5	14/256,315	892	JRE	L237-L238
12/5/2014	SCOT0020-4	13/797,774	892	JRE	U399-U400
12/10/14	SCOT0017-7	14/094,987	892	JRE	U401
12/22/2014			Per BTM instructions	JRE	L239-L255
1/7/2015			Per RAN instructions	JRE	U-402
2/9/2015			Per RAN instructions	JRE	U-403
2/26/2015	SCOT0014-8	14/542,712	892	JRE	U404- U406
3/12/2015	SCOT0014-4	11/895,388	Appeal Decision	JRE	L256

NOTE: MPEP 609.02 Information Disclosure Statements in Continued Examinations or Continuing Applications [R-5] states in part that:

"2. Continuation Applications , Divisional Applications, or Continuation-In-Part Applications Filed Under 37 CFR 1.53(b)

The examiner will consider information which has been considered by the Office in a parent application when examining: (A) a continuation application filed under 37 CFR 1.53(b), (B) a divisional application filed under 37 CFR 1.53(b), or (C) a continuation-in-part application filed

under 37 CFR 1.53(b). A listing of the information need not be resubmitted in the continuing application unless the applicant desires the information to be printed on the patent"

See

<http://mpep.uspto.gov/RDMS/detail/manual/MPEP/e8r9/d0e18.xml#/manual/MPEP/e8r9/d0e53250.xml> (8/2012)

Accordingly, we are submitting only references not cited in the parent application.

Please consider the references cited herein.

Date signed: 3/19/2015

Signature: /BruceMargulies/
Printed Name: Bruce T. Margulies
Attorney of Record

JRE

Printed: March 20, 2015 (12:01pm)

Y:\Clients\SCOT Scott A Moskowitz and Wistaria Trading,
Inc\SCOT0014-4\Drafts\IDS_SCOT0014-4_3-12-2015.wpd

Printed: March 20, 2015 (12:02pm)

Path: Y:\Clients\SCOT Scott A Moskowitz and Wistaria Trading,

Inc\SCOT0014-4\Drafts\ReferenceCitationList_SCOT0014-4_3-12-2015.wpd

37 CFR 1.98(a)(1)(i) APPLICATION & ATTORNEY DOCKET: 11/895,388 / SCOT0014-4

37 CFR 1.98(a)(1)(iii): THIS IS AN INFORMATION DISCLOSURE STATEMENT

LISTING OF UNITED STATES PATENTS - U series

EXAMINER INITIALS	REFERENCE NUMBER (U SERIES)	PATENT NUMBER	ISSUE DATE	NAME OF PATENTEE OR APPLICANT	REFERENCES CITED AND CONSIDERED BY EXAMINER IN PARENT CASE IDENTIFIED BY PLACEMENT OF "X"
	U 01	3947825	March 1976	Cassada	X
	U 02	3984624	October 1976	Waggener	X
	U 03	3986624	October 1976	Cates, Jr. et al.	X
	U 04	4038596	July 1977	Lee	X
	U 05	4200770	April 1980	Hellman et al.	X
	U 06	4218582	August 1980	Hellman et al.	X
	U 07	4339134	July 1982	Macheel	X
	U 08	4390898	June 1983	Bond et al.	X
	U 09	4405829	September 1983	Rivest et al.	X
	U 010	4424414	January 1984	Hellman et al.	X
	U 011	4528588	July 1985	Lofberg	X
	U 012	4672605	June 1987	Hustig et al.	X
	U 013	4748668	May 1988	Shamir et al.	X
	U 014	4789928	December 1988	Fujisaki	X
	U 015	4827508	May 1989	Shear	X
	U 016	4876617	October 1989	Best et al.	X
	U 017	4896275	January 1990	Jackson	X
	U 018	4908873	March 1990	Philibert et al.	X
	U 019	4939515	July 1990	Adelson	X
	U 020	4969204	November 1990	Melnychuk et al.	X
	U 021	4972471	November 1990	Gross et al.	X
	U 022	4977594	December 1990	Shear	X

DATE:	EXAMINER'S SIGNATURE:
-------	-----------------------

Printed: March 20, 2015 (12:02pm)

Path: Y:\Clients\SCOT Scott A Moskowitz and Wistaria Trading,

Inc\SCOT0014-4\Drafts\ReferenceCitationList_SCOT0014-4_3-12-2015.wpd

37 CFR 1.98(a)(1)(i) APPLICATION & ATTORNEY DOCKET: 11/895,388 / SCOT0014-4

37 CFR 1.98(a)(1)(iii): THIS IS AN INFORMATION DISCLOSURE STATEMENT

EXAMINER INITIALS	REFERENCE NUMBER (U SERIES)	PATENT NUMBER	ISSUE DATE	NAME OF PATENTEE OR APPLICANT	REFERENCES CITED AND CONSIDERED BY EXAMINER IN PARENT CASE IDENTIFIED BY PLACEMENT OF "X"
	U 023	4979210	December 1990	Nagata et al.	X
	U 024	4980782	December 1990	Ginkel	X
	U 025	5050213	September 1991	Shear	X
	U 026	5073925	December 1991	Nagata et al.	X
	U 027	5077665	December 1991	Silverman et al.	X
	U 028	5113437	May 1992	Best et al.	X
	U 029	5136581	August 1992	Muehrcke	X
	U 030	5136646	August 1992	Haber et al.	X
	U 031	5136647	August 1992	Haber et al.	X
	U 032	5142576	August 1992	Nadan	X
	U 033	5161210	November 1992	Druyvesteyn et al.	X
	U 034	5210820	May 1993	Kenyon	X
	U 035	5243423	September 1993	DeJean et al.	X
	U 036	5243515	September 1993	Lee	X
	U 037	5287407	February 1994	Holmes	X
	U 038	5319735	June 1994	Preuss et al.	X
	U 039	5341429	August 1994	Stringer et al.	X
	U 040	5341477	August 1994	Pitkin et al.	X
	U 041	5363448	November 1994	Koopman et al.	X
	U 042	5365586	November 1994	Indeck et al.	X
	U 043	5369707	November 1994	Follendore, III	X
	U 044	5379345	January 1995	Greenberg	X
	U 045	5394324	February 1995	Clearwater	X

DATE:	EXAMINER'S SIGNATURE:
-------	-----------------------

Printed: March 20, 2015 (12:02pm)

Path: Y:\Clients\SCOT Scott A Moskowitz and Wistaria Trading,

Inc\SCOT0014-4\Drafts\ReferenceCitationList_SCOT0014-4_3-12-2015.wpd

37 CFR 1.98(a)(1)(i) APPLICATION & ATTORNEY DOCKET: 11/895,388 / SCOT0014-4

37 CFR 1.98(a)(1)(iii): THIS IS AN INFORMATION DISCLOSURE STATEMENT

EXAMINER INITIALS	REFERENCE NUMBER (U SERIES)	PATENT NUMBER	ISSUE DATE	NAME OF PATENTEE OR APPLICANT	REFERENCES CITED AND CONSIDERED BY EXAMINER IN PARENT CASE IDENTIFIED BY PLACEMENT OF "X"
	U 046	5398285	March 1995	Borgelt et al.	X
	U 047	5406627	April 1995	Thompson et al.	X
	U 048	5408505	April 1995	Indeck et al.	X
	U 049	5410598	April 1995	Shear	X
	U 050	5412718	May 1995	Narasimhalv et al.	X
	U 051	5418713	May 1995	Allen	X
	U 052	5428606	June 1995	Moskowitz	X
	U 053	5450490	September 1995	Jensen et al.	X
	U 054	5469536	November 1995	Blank	X
	U 055	5471533	November 1995	Wang et al.	X
	U 056	5478990	December 1995	Montanari et al.	X
	U 057	5479210	December 1995	Cawley et al.	X
	U 058	5487168	January 1996	Geiner et al.	X
	U 059	5493677	February 1996	Balogh et al.	X
	U 060	5497419	March 1996	Hill	X
	U 061	5506795	April 1996	Yamakawa	X
	U 062	5513126	April 1996	Harkins et al.	X
	U 063	5513261	April 1996	Maher	X
	U 064	5530739	June 1996	Okada	X
	U 065	5530751	June 1996	Morris	X
	U 066	5530759	June 1996	Braudaway et al.	X
	U 067	5539735	July 1996	Moskowitz	X
	U 068	5548579	August 1996	Lebrun et al.	X

DATE:	EXAMINER'S SIGNATURE:
-------	-----------------------

Printed: March 20, 2015 (12:02pm)

Path: Y:\Clients\SCOT Scott A Moskowitz and Wistaria Trading,

Inc\SCOT0014-4\Drafts\ReferenceCitationList_SCOT0014-4_3-12-2015.wpd

37 CFR 1.98(a)(1)(i) APPLICATION & ATTORNEY DOCKET: 11/895,388 / SCOT0014-4

37 CFR 1.98(a)(1)(iii): THIS IS AN INFORMATION DISCLOSURE STATEMENT

EXAMINER INITIALS	REFERENCE NUMBER (U SERIES)	PATENT NUMBER	ISSUE DATE	NAME OF PATENTEE OR APPLICANT	REFERENCES CITED AND CONSIDERED BY EXAMINER IN PARENT CASE IDENTIFIED BY PLACEMENT OF "X"
	U 069	5568570	October 1996	Rabbani	X
	U 070	5579124	November 1996	Aijala et al.	X
	U 071	5581703	December 1996	Baugher et al.	X
	U 072	5583488	December 1996	Sala et al.	X
	U 073	5598470	January 1997	Cooper et al.	X
	U 074	5606609	February 1997	Houser et al.	X
	U 075	5613004	March 1997	Cooperman et al.	X
	U 076	5617119	April 1997	Briggs et al.	X
	U 077	5625690	April 1997	Michel et al.	X
	U 078	5629980	May 1997	Stefik et al.	X
	U 079	5633932	May 1997	Davis et al.	X
	U 080	5634040	May 1997	Her et al.	X
	U 081	5636276	June 1997	Brugger	X
	U 082	5636292	June 1997	Rhoads	X
	U 083	5640569	June 1997	Miller et al.	X
	U 084	5646997	July 1997	Barton	X
	U 085	5657461	August 1997	Harkins et al.	X
	U 086	5659726	August 1997	Sandford, II et al.	X
	U 087	5664018	September 1997	Leighton	X
	U 088	5673316	September 1997	Auerbach et al.	X
	U 089	5677952	October 1997	Blakely et al.	X
	U 090	5680462	October 1997	Miller et al.	X
	U 091	5687236	November 1997	Moskowitz et al.	X

DATE:	EXAMINER'S SIGNATURE:
-------	-----------------------

Printed: March 20, 2015 (12:02pm)

Path: Y:\Clients\SCOT Scott A Moskowitz and Wistaria Trading,

Inc\SCOT0014-4\Drafts\ReferenceCitationList_SCOT0014-4_3-12-2015.wpd

37 CFR 1.98(a)(1)(i) APPLICATION & ATTORNEY DOCKET: 11/895,388 / SCOT0014-4

37 CFR 1.98(a)(1)(iii): THIS IS AN INFORMATION DISCLOSURE STATEMENT

EXAMINER INITIALS	REFERENCE NUMBER (U SERIES)	PATENT NUMBER	ISSUE DATE	NAME OF PATENTEE OR APPLICANT	REFERENCES CITED AND CONSIDERED BY EXAMINER IN PARENT CASE IDENTIFIED BY PLACEMENT OF "X"
	U 092	5689587	November 1997	Bender et al.	X
	U 093	5696828	December 1997	Koopman, Jr.	X
	U 094	5719937	February 1998	Warren et al.	X
	U 095	5721788	February 1998	Powell et al.	X
	U 096	5734752	March 1998	Knox	X
	U 097	5737416	April 1998	Cooper et al.	X
	U 098	5737733	April 1998	Eller	X
	U 099	5740244	April 1998	Indeck et al.	X
	U 0100	5745569	April 1998	Moskowitz et al.	X
	U 0101	5748783	May 1998	Rhoads	X
	U 0102	5751811	May 1998	Magnotti et al.	X
	U 0103	5754697	May 1998	Fu et al.	X
	U 0104	5757923	May 1998	Koopman, Jr.	X
	U 0105	5765152	June 1998	Erickson	X
	U 0106	5768396	June 1998	Sone	X
	U 0107	5774452	June 1998	Wolosewicz	X
	U 0108	5790677	August 1998	Fox et al.	X
	U 0109	5799083	August 1998	Brothers et al.	X
	U 0110	5809139	September 1998	Grirod et al.	X
	U 0111	5809160	September 1998	Powell et al.	X
	U 0112	5822432	October 1998	Moskowitz et al.	X
	U 0113	5828325	October 1998	Wolosewicz et al.	X

DATE:	EXAMINER'S SIGNATURE:
-------	-----------------------

Printed: March 20, 2015 (12:02pm)

Path: Y:\Clients\SCOT Scott A Moskowitz and Wistaria Trading,

Inc\SCOT0014-4\Drafts\ReferenceCitationList_SCOT0014-4_3-12-2015.wpd

37 CFR 1.98(a)(1)(i) APPLICATION & ATTORNEY DOCKET: 11/895,388 / SCOT0014-4

37 CFR 1.98(a)(1)(iii): THIS IS AN INFORMATION DISCLOSURE STATEMENT

EXAMINER INITIALS	REFERENCE NUMBER (U SERIES)	PATENT NUMBER	ISSUE DATE	NAME OF PATENTEE OR APPLICANT	REFERENCES CITED AND CONSIDERED BY EXAMINER IN PARENT CASE IDENTIFIED BY PLACEMENT OF "X"
	U 0114	5832119	November 1998	Rhoads	X
	U 0115	5848155	December 1998	Cox	X
	U 0116	5850481	December 1998	Rhoads	X
	U 0117	5859920	January 1999	Daly et al.	X
	U 0118	5860099	January 1999	Milios et al.	X
	U 0119	5862260	January 1999	Rhoads	X
	U 0120	5870474	February 1999	Wasilewski et al.	X
	U 0121	5884033	March 1999	Duvall et al.	X
	U 0122	5889868	March 1999	Moskowitz et al.	X
	U 0123	5893067	April 1999	Bender et al.	X
	U 0124	5894521	April 1999	Conley	X
	U 0125	5903721	May 1999	Sixtus	X
	U 0126	5905800	May 1999	Moskowitz et al.	X
	U 0127	5905975	May 1999	Ausubel	X
	U 0128	5912972	June 1999	Barton	X
	U 0129	5915027	June 1999	Cox et al.	X
	U 0130	5917915	June 1999	Hirose	X
	U 0131	5918223	June 1999	Blum	X
	U 0132	5920900	July 1999	Poole et al.	X
	U 0133	5923763	July 1999	Walker et al.	X
	U 0134	5930369	July 1999	Cox et al.	X
	U 0135	5930377	July 1999	Powell et al	. X
	U 0136	5940134	August 1999	Wirtz	X

DATE:	EXAMINER'S SIGNATURE:
-------	-----------------------

Printed: March 20, 2015 (12:02pm)

Path: Y:\Clients\SCOT Scott A Moskowitz and Wistaria Trading,

Inc\SCOT0014-4\Drafts\ReferenceCitationList_SCOT0014-4_3-12-2015.wpd

37 CFR 1.98(a)(1)(i) APPLICATION & ATTORNEY DOCKET: 11/895,388 / SCOT0014-4

37 CFR 1.98(a)(1)(iii): THIS IS AN INFORMATION DISCLOSURE STATEMENT

EXAMINER INITIALS	REFERENCE NUMBER (U SERIES)	PATENT NUMBER	ISSUE DATE	NAME OF PATENTEE OR APPLICANT	REFERENCES CITED AND CONSIDERED BY EXAMINER IN PARENT CASE IDENTIFIED BY PLACEMENT OF "X"
	U 0137	5943422	August 1999	Van Wie et al.	X
	U 0138	5963909	October 1999	Warren et al.	X
	U 0139	5973731	October 1999	Schwab	X
	U 0140	5974141	October 1999	Saito	X
	U 0141	5991426	November 1999	Cox et al.	X
	U 0142	5999217	December 1999	Berners-Lee	X
	U 0143	6009176	December 1999	Gennaro et al.	X
	U 0144	6029126	February 2000	Malvar	X
	U 0145	6041316	March 2000	Allen	X
	U 0146	6044471	March 2000	Colvin	X
	U 0147	6049838	April 2000	Miller et al.	X
	U 0148	6051029	April 2000	Paterson et al.	X
	U 0149	6061793	May 2000	Tewfik et al.	X
	U 0150	6069914	May 2000	Cox	X
	U 0151	6078664	June 2000	Moskowitz et al.	X
	U 0152	6081251	June 2000	Sakai et al.	X
	U 0153	6081587	June 2000	Reyes et al.	X
	U 0154	6088455	July 2000	Logan et al.	X
	U 0155	6131162	October 2000	Yoshiura et al.	X
	U 0156	6141753	October 2000	Zhao et al.	X
	U 0157	6141754	October 2000	Choy	X
	U 0158	6154571	November 2000	Cox et al.	X
	U 0159	6192138	February 2001	Yamadaji	X

DATE:	EXAMINER'S SIGNATURE:
-------	-----------------------

Printed: March 20, 2015 (12:02pm)

Path: Y:\Clients\SCOT Scott A Moskowitz and Wistaria Trading,

Inc\SCOT0014-4\Drafts\ReferenceCitationList_SCOT0014-4_3-12-2015.wpd

37 CFR 1.98(a)(1)(i) APPLICATION & ATTORNEY DOCKET: 11/895,388 / SCOT0014-4

37 CFR 1.98(a)(1)(iii): THIS IS AN INFORMATION DISCLOSURE STATEMENT

EXAMINER INITIALS	REFERENCE NUMBER (U SERIES)	PATENT NUMBER	ISSUE DATE	NAME OF PATENTEE OR APPLICANT	REFERENCES CITED AND CONSIDERED BY EXAMINER IN PARENT CASE IDENTIFIED BY PLACEMENT OF "X"
	U 0160	6199058	March 2001	Wong et al.	X
	U 0161	6205249	March 2001	Moskowitz	X
	U 0162	6208745	March 2001	Florenio et al.	X
	U 0163	6230268	May 2001	Miwa et al.	X
	U 0164	6233347	May 2001	Chen et al.	X
	U 0165	6233684	May 2001	Stefik et al.	X
	U 0166	6240121	May 2001	Senoh	X
	U 0167	6263313	July 2001	Milstead et al.	X
	U 0168	6272634	August 2001	Tewfik et al.	X
	U 0169	6275988	August 2001	Nagashima et al.	X
	U 0170	6278780	August 2001	Shimada	X
	U 0171	6278791	August 2001	Honsinger et al.	X
	U 0172	6282300	August 2001	Bloom et al.	X
	U 0173	6282650	August 2001	Davis	X
	U 0174	6285775	September 2001	Wu et al.	X
	U 0175	6301663	October 2001	Kato et al.	X
	U 0176	6310962	October 2001	Chung et al.	X
	U 0177	6330335	December 2001	Rhoads	X
	U 0178	6330672	December 2001	Shur	X
	U 0179	6345100	February 2002	Levine	X
	U 0180	6351765	February 2002	Pietropaolo et al.	X
	U 0181	6363483	March 2002	Keshav	X
	U 0182	6373892	April 2002	Ichien et al.	X

DATE:	EXAMINER'S SIGNATURE:
-------	-----------------------

Printed: March 20, 2015 (12:02pm)

Path: Y:\Clients\SCOT Scott A Moskowitz and Wistaria Trading,

Inc\SCOT0014-4\Drafts\ReferenceCitationList_SCOT0014-4_3-12-2015.wpd

37 CFR 1.98(a)(1)(i) APPLICATION & ATTORNEY DOCKET: 11/895,388 / SCOT0014-4

37 CFR 1.98(a)(1)(iii): THIS IS AN INFORMATION DISCLOSURE STATEMENT

EXAMINER INITIALS	REFERENCE NUMBER (U SERIES)	PATENT NUMBER	ISSUE DATE	NAME OF PATENTEE OR APPLICANT	REFERENCES CITED AND CONSIDERED BY EXAMINER IN PARENT CASE IDENTIFIED BY PLACEMENT OF "X"
	U 0183	6373960	April 2002	Conover et al.	X
	U 0184	6374036	April 2002	Ryan et al.	X
	U 0185	6377625	April 2002	Kim	X
	U 0186	6381618	April 2002	Jones et al.	X
	U 0187	6381747	April 2002	Wonfor et al.	X
	U 0188	6385329	May 2002	Sharma et al.	X
	U 0189	6389538	May 2002	Gruse et al.	X
	U 0190	6405203	June 2002	Collart	X
	U 0191	6415041	July 2002	Oami et al.	X
	U 0192	6425081	July 2002	Iwamura	X
	U 0193	6430301	August 2002	Petrovic	X
	U 0194	6430302	August 2002	Rhoads	X
	U 0195	6442283	August 2002	Tewfik et al.	X
	U 0196	6446211	September 2002	Colvin	X
	U 0197	6453252	September 2002	Laroche	X
	U 0198	6457058	September 2002	Ullum et al.	X
	U 0199	6463468	October 2002	Buch et al.	X
	U 0200	6484264	November 2002	Colvin	X
	U 0201	6493457	December 2002	Quackenbush	X
	U 0202	6502195	December 2002	Colvin	X
	U 0203	6522767	February 2003	Moskowitz et al.	X
	U 0204	6522769	February 2003	Rhoads et al.	X
	U 0205	6523113	February 2003	Wehrenberg	X

DATE:	EXAMINER'S SIGNATURE:
-------	-----------------------

Printed: March 20, 2015 (12:02pm)

Path: Y:\Clients\SCOT Scott A Moskowitz and Wistaria Trading,

Inc\SCOT0014-4\Drafts\ReferenceCitationList_SCOT0014-4_3-12-2015.wpd

37 CFR 1.98(a)(1)(i) APPLICATION & ATTORNEY DOCKET: 11/895,388 / SCOT0014-4

37 CFR 1.98(a)(1)(iii): THIS IS AN INFORMATION DISCLOSURE STATEMENT

EXAMINER INITIALS	REFERENCE NUMBER (U SERIES)	PATENT NUMBER	ISSUE DATE	NAME OF PATENTEE OR APPLICANT	REFERENCES CITED AND CONSIDERED BY EXAMINER IN PARENT CASE IDENTIFIED BY PLACEMENT OF "X"
	U 0206	6530021	March 2003	Epstein et al.	X
	U 0207	6532284	March 2003	Walker et al.	X
	U 0208	6539475	March 2003	Cox et al.	X
	U 0209	6557103	April 2003	Boncelet, Jr. et al.	X
	U 0210	6584125	June 2003	Katto	X
	U 0211	6587837	July 2003	Spagna et al.	X
	U 0212	6598162	July 2003	Moskowitz	X
	U 0213	6606393	August 2003	Xie et al.	X
	U 0214	6647424	November 2003	Pearson et al.	X
	U 0215	6658010	December 2003	Enns et al.	X
	U 0216	6665489	December 2003	Collart	X
	U 0217	6668246	December 2003	Yeung et al.	X
	U 0218	6668325	December 2003	Collberg et al	X
	U 0219	6687683	February 2004	Harada et al.	X
	U 0220	6725372	April 2004	Lewis et al	X
	U 0221	6754822	June 2004	Zhao	X
	U 0222	6775772	August 2004	Binding et al.	X
	U 0223	6784354	August 2004	Lu et al.	X
	U 0224	6785815	August 2004	Serret-Avila et al.	X
	U 0225	6785825	August 2004	Colvin	X
	U 0226	6792548	September 2004	Colvin	X
	U 0227	6792549	September 2004	Colvin	X
	U 0228	6795925	September 2004	Colvin	X

DATE:	EXAMINER'S SIGNATURE:
-------	-----------------------

Printed: March 20, 2015 (12:02pm)

Path: Y:\Clients\SCOT Scott A Moskowitz and Wistaria Trading,

Inc\SCOT0014-4\Drafts\ReferenceCitationList_SCOT0014-4_3-12-2015.wpd

37 CFR 1.98(a)(1)(i) APPLICATION & ATTORNEY DOCKET: 11/895,388 / SCOT0014-4

37 CFR 1.98(a)(1)(iii): THIS IS AN INFORMATION DISCLOSURE STATEMENT

EXAMINER INITIALS	REFERENCE NUMBER (U SERIES)	PATENT NUMBER	ISSUE DATE	NAME OF PATENTEE OR APPLICANT	REFERENCES CITED AND CONSIDERED BY EXAMINER IN PARENT CASE IDENTIFIED BY PLACEMENT OF "X"
	U 0229	6799277	September 2004	Colvin	X
	U 0230	6813717	November 2004	Colvin	X
	U 0231	6813718	November 2004	Colvin	X
	U 0232	6823455	November 2004	Macy et al.	X
	U 0233	6834308	December 2004	Ikezoye et al.	X
	U 0234	6842862	January 2005	Chow et al.	X
	U 0235	6853726	February 2005	Moskowitz et al.	X
	U 0236	6857078	February 2005	Colvin	X
	U 0237	6931534	August 2005	Jandel et al.	X
	U 0238	6966002	November 2005	Torrubia-Saez	X
	U 0239	6983337	November 2005	Wold	X
	U 0240	6977894	December 2005	Achilles et al.	X
	U 0241	6978370	December 2005	Kocher	X
	U 0242	6986063	January 2006	Colvin	X
	U 0243	7007166	February 2006	Moskowitz et al.	X
	U 0244	7020285	March 2006	Kirovski et al.	X
	U 0245	7035409	April 2006	Moskowitz	X
	U 0246	7043050	May 2006	Yuval	X
	U 0247	7046808	May 2006	Metois et al.	X
	U 0248	7050396	May 2006	Cohen et al.	X
	U 0249	7051208	May 2006	Venkatesan et al.	X
	U 0250	7058570	June 2006	Yu et al.	X
	U 0251	7093295	August 2006	Saito	X

DATE:	EXAMINER'S SIGNATURE:
-------	-----------------------

Printed: March 20, 2015 (12:02pm)

Path: Y:\Clients\SCOT Scott A Moskowitz and Wistaria Trading,

Inc\SCOT0014-4\Drafts\ReferenceCitationList_SCOT0014-4_3-12-2015.wpd

37 CFR 1.98(a)(1)(i) APPLICATION & ATTORNEY DOCKET: 11/895,388 / SCOT0014-4

37 CFR 1.98(a)(1)(iii): THIS IS AN INFORMATION DISCLOSURE STATEMENT

EXAMINER INITIALS	REFERENCE NUMBER (U SERIES)	PATENT NUMBER	ISSUE DATE	NAME OF PATENTEE OR APPLICANT	REFERENCES CITED AND CONSIDERED BY EXAMINER IN PARENT CASE IDENTIFIED BY PLACEMENT OF "X"
	U 0252	7095874	August 2006	Moskowitz et al	. X
	U 0253	7103184	September 2006	Jian	X
	U 0254	7107451	September 2006	Moskowitz	X
	U 0255	7123718	October 2006	Moskowitz et al.	X
	U 0256	7127615	October 2006	Moskowitz	X
	U 0257	7150003	December 2006	Naumovich et al.	X
	U 0258	7152162	December 2006	Moskowitz et al.	X
	U 0259	7159116	January 2007	Moskowitz	X
	U 0260	7162642	January 2007	Schumann et al.	X
	U 0261	7177429	February 2007	Moskowitz et al.	X
	U 0262	7177430	February 2007	Kim	X
	U 0263	7206649	April 2007	Kirovski et al.	X
	U 0264	7231524	June 2007	Bums	X
	U 0265	7233669.	June 2007	Candalore	X
	U 0266	7240210	July 2007	Michak et al.	X
	U 0267	7266697	September 2007	Kirovski et al	. X
	U 0268	7287275	October 2007	Moskowitz	X
	U 0269	7289643	October 2007	Brunk et al.	X
	U 0270	7343492	March 2008	Moskowitz et al.	X
	U 0271	7346472	March 2008	Moskowitz et al.	X
	U 0272	7362775	April 2008	Moskowitz	X
	U 0273	7363278	April 2008	Schmelzer et al.	X
	U 0274	7409073	August 2008	Moskowitz et al.	X

DATE:	EXAMINER'S SIGNATURE:
-------	-----------------------

Printed: March 20, 2015 (12:02pm)

Path: Y:\Clients\SCOT Scott A Moskowitz and Wistaria Trading,

Inc\SCOT0014-4\Drafts\ReferenceCitationList_SCOT0014-4_3-12-2015.wpd

37 CFR 1.98(a)(1)(i) APPLICATION & ATTORNEY DOCKET: 11/895,388 / SCOT0014-4

37 CFR 1.98(a)(1)(iii): THIS IS AN INFORMATION DISCLOSURE STATEMENT

EXAMINER INITIALS	REFERENCE NUMBER (U SERIES)	PATENT NUMBER	ISSUE DATE	NAME OF PATENTEE OR APPLICANT	REFERENCES CITED AND CONSIDERED BY EXAMINER IN PARENT CASE IDENTIFIED BY PLACEMENT OF "X"
	U 0275	7457962	November 2008	Moskowitz	X
	U 0276	7460994	December 2008	Herre et al.	X
	U 0277	7475246	January 2009	Moskowitz	X
	U 0278	7530102	May 2009	Moskowitz	X
	U 0279	7532725	May 2009	Moskowitz et al.	X
	U 0280	7568100	July 2009	Moskowitz et al.	X
	U 0281	7647502	January 2010	Moskowitz	X
	U 0282	7647503	January 2010	Moskowitz	X
	U 0283	7779261	August 2010	Moskowitz	X
	U 0284	6990453	January 2006	Wang	X
	U 0285	6081597	June 2000	Hoffstein	X
	U 0286	7035049	Apr 2006	Yamamoto	X
	U 0287	7664263	Feb 2010	Moskowitz	X
	U 0288	7286451	Oct 2007	Wirtz	X
	U 0289	6385324	May 2002	Koppen	X
	U 0290	6674858	Jan 2004	Kimura	X
	U 0291	6148333	Nov 2000	Guedalia	X
	U 0292	6418421	Jun 2002	Hurtado	X
	U 0293	6385596	May 2002	Wiser	X
	U 0294	6226618	May 2001	Downs	X
	U 0295	6957330	Oct 2005	Hughes	X
	U 0296	5842213	Nov 1998	Odom	X
	U 0297	5818818	Oct 1998	Soumiya	X

DATE:	EXAMINER'S SIGNATURE:
-------	-----------------------

Printed: March 20, 2015 (12:02pm)

Path: Y:\Clients\SCOT Scott A Moskowitz and Wistaria Trading,

Inc\SCOT0014-4\Drafts\ReferenceCitationList_SCOT0014-4_3-12-2015.wpd

37 CFR 1.98(a)(1)(i) APPLICATION & ATTORNEY DOCKET: 11/895,388 / SCOT0014-4

37 CFR 1.98(a)(1)(iii): THIS IS AN INFORMATION DISCLOSURE STATEMENT

EXAMINER INITIALS	REFERENCE NUMBER (U SERIES)	PATENT NUMBER	ISSUE DATE	NAME OF PATENTEE OR APPLICANT	REFERENCES CITED AND CONSIDERED BY EXAMINER IN PARENT CASE IDENTIFIED BY PLACEMENT OF "X"
	U 0298	6590996	Jun 2003	Reed	X
	U 0299	5949055	Sept 1999	Fleet	X
	U 0300	6067622	May 2000	Moore	X
	U 0301	7761712	Jun 2010	Moskowitz	X
	U 0302	7743001	Jun 2010	Vermeulen	X
	U 0303	6865747	Mar 2005	Mercier	
	U 0304	6611599	Aug 2003	Natarajan	
	U 0305	6480937	Nov 2002	Vorbach	
	U 0306	6398245	Jun 2002	Gruse	
	U 0307	6950941	Sept 2005	Lee	
	U 0308	6983058	Jan 2006	Fukuoka	
	U 0309	5675653	Oct 1997	Nelson	
	U 0310	6804453	Oct 2004	Sasamoto	
	U 0311	6178405	Jan 2001	Ouyang	
	U 0312	5839100	Nov 1998	Wegener	
	U 0313	5781184	Jul 1998	Wasserman	
	U 0314	5617506	Apr 1997	Burk	
	U 0315	5327520	Jul 1994	Chen	
	U 0316	5111530	May 1992	Kutaragi	
	U 0317	7095715	Aug 2006	Buckman	
	U 0318	6173322	Jan 2001	Hu	
	U 0319	5754938	May 1998	Herz	
	U 0320	6035398	Mar 2000	Bjorn	

DATE:	EXAMINER'S SIGNATURE:
-------	-----------------------

Printed: March 20, 2015 (12:02pm)

Path: Y:\Clients\SCOT Scott A Moskowitz and Wistaria Trading,

Inc\SCOT0014-4\Drafts\ReferenceCitationList_SCOT0014-4_3-12-2015.wpd

37 CFR 1.98(a)(1)(i) APPLICATION & ATTORNEY DOCKET: 11/895,388 / SCOT0014-4

37 CFR 1.98(a)(1)(iii): THIS IS AN INFORMATION DISCLOSURE STATEMENT

EXAMINER INITIALS	REFERENCE NUMBER (U SERIES)	PATENT NUMBER	ISSUE DATE	NAME OF PATENTEE OR APPLICANT	REFERENCES CITED AND CONSIDERED BY EXAMINER IN PARENT CASE IDENTIFIED BY PLACEMENT OF "X"
	U 0321	5901178	May 1999	Lee	
	U 0322	8214175	July 2012	Moskowitz	
	U 0323	8265278	Sept 2012	Moskowitz	
	U 0324	8161286	Nov 2010	Moskowitz	
	U 0325	8307213	Jan 2011	Moskowitz	
	U 0326	8121343	May 2012	Moskowitz	
	U 0327	5437050	Jul 1995	Lamb	
	U 0328	5123045	Jun 1992	Ostrovsky	
	U 0329	7310815	Dec 2007	Yanovsky	
	U 0330	8179846	May 2012	Dolganow	
	U 0331	7719966	May 2010	Luft	
	U 0332	7630379	Dec 2009	Morishita	
	U 0333	5949973	Sept 1999	Yarom	
	U 0334	8400566	Mar. 2013	Terry	
	U 0335	5649284	July 1997	Yoshinobu	
	U 0336	7444506	Oct 2008	Datta	
	U 0337	6480963	Oct 2002	Tachibana	
	U 0338	6510513	Jan 2003	Darrow	
	U 0339	5189411	Feb 1993	Collar	
	U 0340	5293633	Mar 1994	Robbins	
	U 0341	4633462	Dec 1986	Stifle	
	U 0342	5103461	Mar 1992	Cain	
	U 0343	6272535	Aug 2001	Iwamura	

DATE:	EXAMINER'S SIGNATURE:
-------	-----------------------

Printed: March 20, 2015 (12:02pm)

Path: Y:\Clients\SCOT Scott A Moskowitz and Wistaria Trading,

Inc\SCOT0014-4\Drafts\ReferenceCitationList_SCOT0014-4_3-12-2015.wpd

37 CFR 1.98(a)(1)(i) APPLICATION & ATTORNEY DOCKET: 11/895,388 / SCOT0014-4

37 CFR 1.98(a)(1)(iii): THIS IS AN INFORMATION DISCLOSURE STATEMENT

EXAMINER INITIALS	REFERENCE NUMBER (U SERIES)	PATENT NUMBER	ISSUE DATE	NAME OF PATENTEE OR APPLICANT	REFERENCES CITED AND CONSIDERED BY EXAMINER IN PARENT CASE IDENTIFIED BY PLACEMENT OF "X"
	U 0344	6029195	Feb 2000	Herz	
	U 0345	8095949	Jan 2012	Hendricks	
	U 0346	5297032	Mar 1994	Trojan	
	U 0347	5644727	Jul 1997	Atkins	
	U 0348	5721781	Feb 1998	Deo	
	U 0349	5822436	Oct 1998	Rhoads	
	U 0350	5845266	Dec 1998	Lupien	
	U 0351	5864827	Jan 1999	Wilson	
	U 0352	5875437	Feb 1999	Atkins	
	U 0353	5892900	Apr 1999	Ginter	
	U 0354	6108722	Aug 2000	Troeller	
	U 0355	6029146	Feb 2000	Hawkins	
	U 0356	6032957	Mar 2000	Kiyosaki	
	U 0357	6134535	Oct 2000	Belzberg	
	U 0358	6185683	Feb 2001	Ginter	
	U 0359	6233566	May 2001	Levine	
	U 0360	6253193	Jun 2001	Ginter	
	U 0361	6272474	Aug 2001	Garcia	
	U 0362	6317728	Nov 2001	Kane	
	U 0363	6363488	Mar 2002	Ginter	
	U 0364	6389402	May 2002	Ginter	
	U 0365	6427140	Jul 2002	Ginter	
	U 0366	6484153	Nov 2002	Walker	

DATE:	EXAMINER'S SIGNATURE:
-------	-----------------------

Printed: March 20, 2015 (12:02pm)

Path: Y:\Clients\SCOT Scott A Moskowitz and Wistaria Trading,

Inc\SCOT0014-4\Drafts\ReferenceCitationList_SCOT0014-4_3-12-2015.wpd

37 CFR 1.98(a)(1)(i) APPLICATION & ATTORNEY DOCKET: 11/895,388 / SCOT0014-4

37 CFR 1.98(a)(1)(iii): THIS IS AN INFORMATION DISCLOSURE STATEMENT

EXAMINER INITIALS	REFERENCE NUMBER (U SERIES)	PATENT NUMBER	ISSUE DATE	NAME OF PATENTEE OR APPLICANT	REFERENCES CITED AND CONSIDERED BY EXAMINER IN PARENT CASE IDENTIFIED BY PLACEMENT OF "X"
	U 0367	6556976	Aug 1987	Callen	
	U 0368	6574608	Jun 2003	Dahod	
	U 0369	6601044	Jul 2003	Wallman	
	U 0370	6594643	Jul 2003	Freeny	
	U 0371	6618188	Sep 2003	Haga	
	U 0372	6778968	Aug 2004	Gulati	
	U 0373	6839686	Jan 2005	Galant	
	U 0374	6856867	Feb 2005	Woolston	
	U 0375	6876982	Apr 2005	Lancaster	
	U 0376	7003480	Feb 2006	Fox	
	U 0377	5822436	Oct 1998	Rhoads	
	U 0378	6324649	Nov 2001	Eyres	
	U 0379	5375055	Dec 1994	Togher	
	U 0380	6018722	Jan 2000	Ray	
	U 0381	6138239	Oct 2000	Veil	
	U 0382	6484153	Nov 2002	Walker	
	U 0383	6615188	Aug 2004	Breen	
	U 0384	6856967	Jan 2005	Woolston	
	U 0385	5790783	Aug 1998	Lee	
	U 0386	6650761	Nov 2003	Rodriguez	
	U 0387	6735702	May 2004	Yavatkar	
	U 0388	6792424	Sept 2004	Burns	
	U 0389	4790564	Dec 1988	Larcher	

DATE:	EXAMINER'S SIGNATURE:
-------	-----------------------

Printed: March 20, 2015 (12:02pm)

Path: Y:\Clients\SCOT Scott A Moskowitz and Wistaria Trading,

Inc\SCOT0014-4\Drafts\ReferenceCitationList_SCOT0014-4_3-12-2015.wpd

37 CFR 1.98(a)(1)(i) APPLICATION & ATTORNEY DOCKET: 11/895,388 / SCOT0014-4

37 CFR 1.98(a)(1)(iii): THIS IS AN INFORMATION DISCLOSURE STATEMENT

EXAMINER INITIALS	REFERENCE NUMBER (U SERIES)	PATENT NUMBER	ISSUE DATE	NAME OF PATENTEE OR APPLICANT	REFERENCES CITED AND CONSIDERED BY EXAMINER IN PARENT CASE IDENTIFIED BY PLACEMENT OF "X"
	U 0390	6111517	Aug 2000	Atick	
	U 0391	5164992	Nov 1992	Turk	
	U 0392	6674877	Jan 2004	Jojie	
	U 0393	5291560	Mar 1994	Daugman	
	U 0394	8492633	Jul 2013	Ellis	
	U 0395	7672838	Mar 2010	Ellis	
	U 0396	7254538	Aug 2007	Ellis	
	U 0397	7812241	Oct 2010	Ellis	
	U 0398	7672916	Mar 2010	Poliner	
	U 0399	5991431	Nov 1999	Borza	
	U 0400	4529870	Jul 1985	Chaum	
	U 0401	6704451	Mar 2004	Hekstra	
	U 0402	6532298	Mar 2003	Cambier	
	U 0403	8949619	Feb 2015	Parry	
	U 0404	4855584	Aug 1989	Tomiyama	
	U 0405	4749354	Jun 1988	Kerman	
	U 0406	5570339	Oct 1996	Nagano	

DATE:	EXAMINER'S SIGNATURE:
-------	-----------------------

Printed: March 20, 2015 (12:02pm)

Path: Y:\Clients\SCOT Scott A Moskowitz and Wistaria Trading,

Inc\SCOT0014-4\Drafts\ReferenceCitationList_SCOT0014-4_3-12-2015.wpd

37 CFR 1.98(a)(1)(i) APPLICATION & ATTORNEY DOCKET: 11/895,388 / SCOT0014-4

37 CFR 1.98(a)(1)(iii): THIS IS AN INFORMATION DISCLOSURE STATEMENT

LISTING OF UNITED STATES PUBLISHED APPLICATIONS - P Series

EXAMINER INITIALS	REFERENCE NUMBER (P SERIES)	PUBLICATION NUMBER	PUBLICATION DATE	NAME OF PATENTEE OR APPLICANT	REFERENCES CITED AND CONSIDERED BY EXAMINER IN PARENT CASE IDENTIFIED BY PLACEMENT OF "X"
	P 01	20010010078	July 2001	Moskowitz	X
	P 02	20010043594	November 2001	Ogawa et al.	X
	P 03	20020010684	January 2002	Moskowitz	X
	P 04	20020026343	February 2002	Duenke	X
	P 05	20020056041	May 2002	Moskowitz	X
	P 06	20020071556	June 2002	Moskowitz et al.	X
	P 07	20020073043	June 2002	Herman et al.	X
	P 08	20020097873	July 2002	Petrovic	X
	P 09	20020103883	August 2002	Haverstock et al.	X
	P 010	20020161741	October 2002	Wang et al.	X
	P 011	20030126445	July 2003	Wehrenberg	X
	P 012	20030133702	July 2003	Collart	X
	P 013	20030200439	October 2003	Moskowitz	X
	P 014	20030219143	November 2003	Moskowitz et al.	X
	P 015	20040028222	February 2004	Sewell et al.	X
	P 016	20040037449	February 2004	Davis et al.	X
	P 017	20040049695	March 2004	Choi et al.	X
	P 018	20040059918	March 2004	Xu	X
	P 019	20040083369	April 2004	Erlingsson et al.	X
	P 020	20040086119	May 2004	Moskowitz	X
	P 021	20040093521	May 2004	Hamadeh et al.	X
	P 022	20040117628	June 2004	Colvin	X

DATE:	EXAMINER'S SIGNATURE:
-------	-----------------------

Printed: March 20, 2015 (12:02pm)

Path: Y:\Clients\SCOT Scott A Moskowitz and Wistaria Trading,

Inc\SCOT0014-4\Drafts\ReferenceCitationList_SCOT0014-4_3-12-2015.wpd

37 CFR 1.98(a)(1)(i) APPLICATION & ATTORNEY DOCKET: 11/895,388 / SCOT0014-4

37 CFR 1.98(a)(1)(iii): THIS IS AN INFORMATION DISCLOSURE STATEMENT

EXAMINER INITIALS	REFERENCE NUMBER (P SERIES)	PUBLICATION NUMBER	PUBLICATION DATE	NAME OF PATENTEE OR APPLICANT	REFERENCES CITED AND CONSIDERED BY EXAMINER IN PARENT CASE IDENTIFIED BY PLACEMENT OF "X"
	P 023	20040117664	June 2004	Colvin	X
	P 024	20040125983	July 2004	Reed et al.	X
	P 025	20040128514.	July 2004	Rhoads	X
	P 026	20040225894	November 2004	Colvin	X
	P 027	20040243540	December 2004	Moskowitz et al.	X
	P 028	20050135615	June 2005	Moskowitz et al.	X
	P 029	20050160271	July 2005	Brundage et al.	X
	P 030	20050177727	August 2005	Moskowitz et al.	X
	P 031	20050246554	November 2005	Batson	X
	P 032	20060005029	January 2006	Petrovic et al.	X
	P 033	20060013395	January 2006	Brundage et al.	X
	P 034	20060013451	January 2006	Haitsma	X
	P 035	20060041753	February 2006	Haitsma	X
	P 036	20060101269	May 2006	Moskowitz et al.	X
	P 037	20060140403	June 2006	Moskowitz	X
	P 038	20060285722	December 2006	Moskowitz et al.	X
	P 039	20070011458	January 2007	Moskowitz	X
	P 040	20070028113	February 2007	Moskowitz	X
	P 041	20070064940	March 2007	Moskowitz et al.	X
	P 042	20070079131.	April 2007	Moskowitz et al.	X
	P 043	20070083467	April 2007	Lindahl et al.	X
	P 044	20070110240	May 2007	Moskowitz et al.	X
	P 045	20070113094	May 2007	Moskowitz et al.	X

DATE:	EXAMINER'S SIGNATURE:
-------	-----------------------

Printed: March 20, 2015 (12:02pm)

Path: Y:\Clients\SCOT Scott A Moskowitz and Wistaria Trading,

Inc\SCOT0014-4\Drafts\ReferenceCitationList_SCOT0014-4_3-12-2015.wpd

37 CFR 1.98(a)(1)(i) APPLICATION & ATTORNEY DOCKET: 11/895,388 / SCOT0014-4

37 CFR 1.98(a)(1)(iii): THIS IS AN INFORMATION DISCLOSURE STATEMENT

EXAMINER INITIALS	REFERENCE NUMBER (P SERIES)	PUBLICATION NUMBER	PUBLICATION DATE	NAME OF PATENTEE OR APPLICANT	REFERENCES CITED AND CONSIDERED BY EXAMINER IN PARENT CASE IDENTIFIED BY PLACEMENT OF "X"
	P 046	20070127717	June 2007	Herre et al.	X
	P 047	20070226506	September 2007	Moskowitz	X
	P 048	20070253594	November 2007	Lu et al.	X
	P 049	20070294536	December 2007	Moskowitz et al.	X
	P 050	20070300072	December 2007	Moskowitz	X
	P 051	20070300073	December 2007	Moskowitz	X
	P 052	20080005571	January 2008	Moskowitz	X
	P 053	20080005572	January 2008	Moskowitz	X
	P 054	20080016365	January 2008	Moskowitz	X
	P 055	20080022113	January 2008	Moskowitz	X
	P 056	20080022114	January 2008	Moskowitz	X
	P 057	20080028222	January 2008	Moskowitz	X
	P 058	20080046742	February 2008	Moskowitz	X
	P 059	20080075277	March 2008	Moskowitz et al.	X
	P 060	20080109417	May 2008	Moskowitz	X
	P 061	20080133927	June 2008	Moskowitz et al.	X
	P 062	20080151934	June 2008	Moskowitz et al.	X
	P 063	20090037740	February 2009	Moskowitz	X
	P 064	20090089427	April 2009	Moskowitz et al.	X
	P 065	20090190754	July 2009	Moskowitz et al.	X
	P 066	20090210711	August 2009	Moskowitz	X
	P 067	20090220074	September 2009	Moskowitz et al.	X
	P 068	20100002904	January 2010	Moskowitz	X

DATE:	EXAMINER'S SIGNATURE:
-------	-----------------------

Printed: March 20, 2015 (12:02pm)

Path: Y:\Clients\SCOT Scott A Moskowitz and Wistaria Trading,

Inc\SCOT0014-4\Drafts\ReferenceCitationList_SCOT0014-4_3-12-2015.wpd

37 CFR 1.98(a)(1)(i) APPLICATION & ATTORNEY DOCKET: 11/895,388 / SCOT0014-4

37 CFR 1.98(a)(1)(iii): THIS IS AN INFORMATION DISCLOSURE STATEMENT

EXAMINER INITIALS	REFERENCE NUMBER (P SERIES)	PUBLICATION NUMBER	PUBLICATION DATE	NAME OF PATENTEE OR APPLICANT	REFERENCES CITED AND CONSIDERED BY EXAMINER IN PARENT CASE IDENTIFIED BY PLACEMENT OF "X"
	P 069	20100005308	January 2010	Moskowitz	X
	P 070	20100098251	Apr 2010	Moskowitz	X
	P 071	20100220861	Sept 2010	Moskowitz	X
	P 072	20100202607	Aug 2010	Moskowitz	X
	P 073	20020047873	June 2002	Petrovic	X
	P 074	20020009208	Jan 2002	Alattar	X
	P 075	20010029580	October 2001	Moskowitz	X
	P 076	20100182570	July 2010	Chota	X
	P 077	20100077220	March 2010	Moskowitz	X
	P 078	20100077219	March 2010	Moskowitz	X
	P 079	20100064140	March 2010	Moskowitz	X
	P 080	20100153734	June 2010	Moskowitz	X
	P 081	20100106736	April 2010	Moskowitz	X
	P 082	20060251291	November 2006	Rhoads	X
	P 083	20030002862	January 2003	Rodriguez	
	P 084	20030005780	May 2003	Hansen	
	P 085	20020152179	Oct 2002	Racov	
	P 086	20030027549	Feb 2003	Kiel	
	P 087	20020057651	May 2002	Roberts	
	P 088	20110069864	March 2011	Moskowitz	
	P 089	20100313033	Dec 2010	Moskowitz	
	P 090	20110019691	Jan 2011	Moskowitz	
	P 091	20030023852	Jan. 2003	Wold	

DATE:	EXAMINER'S SIGNATURE:
-------	-----------------------

Printed: March 20, 2015 (12:02pm)

Path: Y:\Clients\SCOT Scott A Moskowitz and Wistaria Trading,

Inc\SCOT0014-4\Drafts\ReferenceCitationList_SCOT0014-4_3-12-2015.wpd

37 CFR 1.98(a)(1)(i) APPLICATION & ATTORNEY DOCKET: 11/895,388 / SCOT0014-4

37 CFR 1.98(a)(1)(iii): THIS IS AN INFORMATION DISCLOSURE STATEMENT

EXAMINER INITIALS	REFERENCE NUMBER (P SERIES)	PUBLICATION NUMBER	PUBLICATION DATE	NAME OF PATENTEE OR APPLICANT	REFERENCES CITED AND CONSIDERED BY EXAMINER IN PARENT CASE IDENTIFIED BY PLACEMENT OF "X"
	P 092	20030033321	Feb 2003	Schrempp	
	P 093	20130145058	June 2013	Shuholm	
	P 094	20120057012	Mar. 2012	Sitrick	
	P 095	20110128445	Jun 2011	Carrieres	
	P 096	20020188570	Dec 2002	Holliman	
	P 097	20020069174	Jun 2002	Fox	
	P 098	20130226957	Feb 27 2013	Ellis	

DATE:	EXAMINER'S SIGNATURE:
-------	-----------------------

Printed: March 20, 2015 (12:02pm)

Path: Y:\Clients\SCOT Scott A Moskowitz and Wistaria Trading,

Inc\SCOT0014-4\Drafts\ReferenceCitationList_SCOT0014-4_3-12-2015.wpd

37 CFR 1.98(a)(1)(i) APPLICATION & ATTORNEY DOCKET: 11/895,388 / SCOT0014-4

37 CFR 1.98(a)(1)(iii): THIS IS AN INFORMATION DISCLOSURE STATEMENT

LISTING OF FOREIGN AND INTERNATIONAL PATENT DOCUMENTS - F Series

EXAMINER INITIALS	REFERENCE NUMBER (F SERIES)	PUBLICATION NUMBER	PUBLICATION DATE	COUNTRY OR REGION	PAGE/LINE AND FIGURE/ELEMENT OF RELEVANT MATERIAL	REFERENCES CITED AND CONSIDERED BY EXAMINER IN PARENT CASE IDENTIFIED BY PLACEMENT OF "X"
	F 01-	EP0372601	Jun., 1990	EP		X
	F 02-	EP0565947	Oct., 1993	EP		X
	F 03-	EP0581317	Feb., 1994	EP		X
	F 04-	EP0649261	Apr., 1995	EP		X
	F 05-	EP0651554	May., 1995	EP		X
	F 06-	EP1354276	Dec., 2007	EP		X
	F 07-	NL 1005523	Sep., 1998	NL		X
	F 08-	WO 9514289	May., 1995	WO		X
	F 09-	WO 9629795	Sep., 1996	WO		X
	F 010-	WO 9724833	Jul., 1997	WO		X
	F 011-	WO 9744736	Nov., 1997	WO		X
	F 012-	WO9837513	Aug., 1998	WO		X
	F 013-	WO 9952271	Oct., 1999	WO		X
	F 014-	WO 9962044	Dec., 1999	WO		X
	F 015-	WO 9963443	Dec., 1999	WO		X
	F 016-	WO9726733	Jan. 1997	WO		X
	F 017-	WO98002864	Jul. 1997	WO		X
	F 018-	WO 0057643	Sept 2000	WO		X
	F 019-	WO 9642151	Dec 1996	WO		X
	F 020-	EP0872073	July 1996	EP		X
	F 021-	WO0118628	March 2001	WO		X
	F 022-	WO0143026	June 2001	WO		X

DATE:	EXAMINER'S SIGNATURE:
-------	-----------------------

Printed: March 20, 2015 (12:02pm)

Path: Y:\Clients\SCOT Scott A Moskowitz and Wistaria Trading,

Inc\SCOT0014-4\Drafts\ReferenceCitationList_SCOT0014-4_3-12-2015.wpd

37 CFR 1.98(a)(1)(i) APPLICATION & ATTORNEY DOCKET: 11/895,388 / SCOT0014-4

37 CFR 1.98(a)(1)(iii): THIS IS AN INFORMATION DISCLOSURE STATEMENT

EXAMINER INITIALS	REFERENCE NUMBER (F SERIES)	PUBLICATION NUMBER	PUBLICATION DATE	COUNTRY OR REGION	PAGE/LINE AND FIGURE/ELEMENT OF RELEVANT MATERIAL	REFERENCES CITED AND CONSIDERED BY EXAMINER IN PARENT CASE IDENTIFIED BY PLACEMENT OF "X"
	F 023-	WO0203385	Jan 2002	WO		X
	F 024-	WO9701892	June 1995	WO		X
	F 025-	WO9726732	July 1997	WO		X
	F 026-	WO9802864	Jan 1998	WO		X
	F 027-	EP1547337	Mar 2006	EP		X
	F 028-	EP0581317A2	Feb 1994	EP		X
	F 029-	WO023385A1	Oct 2002	WO		X

DATE:	EXAMINER'S SIGNATURE:
-------	-----------------------

Printed: March 20, 2015 (12:02pm)

Path: Y:\Clients\SCOT Scott A Moskowitz and Wistaria Trading,

Inc\SCOT0014-4\Drafts\ReferenceCitationList_SCOT0014-4_3-12-2015.wpd

37 CFR 1.98(a)(1)(i) APPLICATION & ATTORNEY DOCKET: 11/895,388 / SCOT0014-4

37 CFR 1.98(a)(1)(iii): THIS IS AN INFORMATION DISCLOSURE STATEMENT

LISTING OF NON PATENT LITERATURE - L Series

EXAMINER INITIAL	REF. NO. (L series)	REFERENCE NUMBER (L Series)	PUB. DATE	INCLUDE IN SEQUENCE: Name of first author (in CAPITAL LETTERS), Title in quotation marks, name of publication, date or publication, page numbers, publisher, city of publication, and country of publication NOTE - For US patent applications listed herein, if a	REFERENCES CITED AND CONSIDERED BY EXAMINER IN PARENT CASE IDENTIFIED BY PLACEMENT OF "X"
	1	L- 01	N/A	US. Appl. No. 08/999,766, filed Jul. 23, 1997, entitled "Steganographic Method and Device", published as 7568100 07-28-2009, cited as U280.	X
	2	L- 02	N/A	EPO Application No. 96919405.9, entitled "Steganographic Method and Device"; published as EP0872073 (A2), 10-21-1998, cited herein as F20.	X
	3	L- 03	N/A	U.S. Appl. No. 11/050,779, filed Feb. 7, 2005, entitled "Steganographic Method and Device", published as 20050177727 A1 08-11-2005, cited herein as P30.	X
	4	L- 04	N/A	U.S. Appl. No. 08/674,726, filed Jul. 2, 1996, entitled "Exchange Mechanisms for Digital Information Packages with Bandwidth Securitization, Multichannel Digital Watermarks, and Key Management", published as 7362775 04-22-2008, cited herein as U272 .	X
	5	L- 05	N/A	U.S. Appl. No. 09/545,589, filed Apr. 7, 2000, entitled "Method and System for Digital Watermarking", published as 7007166 02-28-2006, cited herein as U243	X
	6	L- 06	N/A	U.S. Appl. No. 11/244,213, filed Oct. 5, 2005, entitled "Method and System for Digital Watermarking", published as 2006-0101269 A1 05-11-2006, cited herein as P36	X
	7	L- 07	N/A	U.S. Appl. No. 11/649,026, filed Jan. 3, 2007, entitled "Method and System for Digital Watermarking", published as 2007-0113094 A1 05-17-2007, cited herein as P45.	X
	8	L- 08	N/A	U.S. Appl. No. 09/046,627, filed Mar. 24, 1998, entitled "Method for Combining Transfer Function with Predetermined Key Creation", published as 6,598,162 07-22-2003, cited herein as U212.	X
	9	L- 09	N/A	U.S. Appl. No. 10/602,777, filed Jun. 25, 2003, entitled "Method for Combining Transfer Function with Predetermined Key Creation", published as 2004-0086119 A1 05-06-2004, cited herein P20.	X

DATE:	EXAMINER'S SIGNATURE:
-------	-----------------------

Printed: March 20, 2015 (12:02pm)

Path: Y:\Clients\SCOT Scott A Moskowitz and Wistaria Trading,

Inc\SCOT0014-4\Drafts\ReferenceCitationList_SCOT0014-4_3-12-2015.wpd

37 CFR 1.98(a)(1)(i) APPLICATION & ATTORNEY DOCKET: 11/895,388 / SCOT0014-4

37 CFR 1.98(a)(1)(iii): THIS IS AN INFORMATION DISCLOSURE STATEMENT

EXAMINER INITIAL	REF. NO. (L series)	REFERENCE NUMBER (L Series)	PUB. DATE	INCLUDE IN SEQUENCE: Name of first author (in CAPITAL LETTERS), Title in quotation marks, name of publication, date or publication, page numbers, publisher, city of publication, and country of publication NOTE - For US patent applications listed herein, if a	REFERENCES CITED AND CONSIDERED BY EXAMINER IN PARENT CASE IDENTIFIED BY PLACEMENT OF "X"
	10	L- 010	N/A	U.S. Appl. No. 09/053,628, filed Apr. 2, 1998, entitled "Multiple Transform Utilization and Application for Secure Digital Watermarking", 6,205,249 03-20-2001, cited herein as U161.	X
	11	L- 011	N/A	U.S. Appl. No. 09/644,098, filed Aug. 23, 2000, entitled "Multiple Transform Utilization and Application for Secure Digital Watermarking", published as 7,035,409 04-25-2006, cited herein as U245.	X
	12	L- 012	N/A	Jap. App. No. 2000-542907, entitled "Multiple Transform Utilization and Application for Secure Digital Watermarking"; which is a JP national stage of PCT/US1999/007262, published as WO/1999/052271, 10/14/1999, F13 here in above..	X
	13	L- 013	N/A	U.S. Appl. No. 09/767,733, filed Jan. 24, 2001 entitled "Multiple Transform Utilization and Application for Secure Digital Watermarking", published as 2001-0010078 A1 07-26-2001, cited herein as P1.	X
	14	L- 014	N/A	U.S. Appl. No. 11/358,874, filed Feb. 21, 2006, entitled "Multiple Transform Utilization and Application for Secure Digital Watermarking", published as 2006-0140403 A1 06-29-2006, cited herein as P37.	X
	15	L- 015	N/A	U.S. Appl. No. 10/417,231, filed Apr. 17, 2003, entitled "Methods, Systems And Devices For Packet Watermarking And Efficient Provisioning Of Bandwidth", published as 2003-0200439 A1 10-23-2003, cited herein as P13,	X
	16	L- 016	N/A	U.S. Appl. No. 09/789,711, filed Feb. 22, 2001, entitled "Optimization Methods for the Insertion, Protection, and Detection of Digital Watermarks in Digital Data", published as 2001-0029580 A1 10-11-2001, cited herein as P75.	X
	17	L- 017	N/A	U.S. Appl. No. 11/497,822, filed Aug. 2, 2006, entitled "Optimization Methods for the Insertion, Protection, and Detection of Digital Watermarks in Digital Data", published as 2007-0011458 A1 01-11-2007, cited herein as P39.	X

DATE:	EXAMINER'S SIGNATURE:
-------	-----------------------

Printed: March 20, 2015 (12:02pm)

Path: Y:\Clients\SCOT Scott A Moskowitz and Wistaria Trading,

Inc\SCOT0014-4\Drafts\ReferenceCitationList_SCOT0014-4_3-12-2015.wpd

37 CFR 1.98(a)(1)(i) APPLICATION & ATTORNEY DOCKET: 11/895,388 / SCOT0014-4

37 CFR 1.98(a)(1)(iii): THIS IS AN INFORMATION DISCLOSURE STATEMENT

EXAMINER INITIAL	REF. NO. (L series)	REFERENCE NUMBER (L Series)	PUB. DATE	INCLUDE IN SEQUENCE: Name of first author (in CAPITAL LETTERS), Title in quotation marks, name of publication, date or publication, page numbers, publisher, city of publication, and country of publication NOTE - For US patent applications listed herein, if a	REFERENCES CITED AND CONSIDERED BY EXAMINER IN PARENT CASE IDENTIFIED BY PLACEMENT OF "X"
	18	L- 018	N/A	U.S. Appl. No. 11/599,964, filed Nov. 15, 2006, entitled "Optimization Methods for the Insertion, Protection, and Detection of Digital Watermarks in Digital Data", published as 2008-0046742 A1 02-21-2008, cited herein as P58.	X
	19	L- 019	N/A	U.S. Appl. No. 11/599,838, filed Nov. 15, 2006, entitled "Optimization Methods for the Insertion, Protection, and Detection of Digital Watermarks in Digital Data", published as 2007-0226506 A1 09-27-2007, cited herein as P47.	X
	20	L- 020	N/A	U.S. Appl. No. 10/369,344, filed Feb. 18, 2003, entitled "Optimization Methods for the Insertion, Protection, and Detection of Digital Watermarks in Digitized Data", published as 2003-0219143 A1 11-27-2003, cited herein as P14.	X
	21	L- 021	N/A	U.S. Appl. No. 11/482,654, filed Jul. 7, 2006, entitled "Optimization Methods for the Insertion, Protection, and Detection of Digital Watermarks in Digitized Data", published as 2006-0285722 A1 12-21-2006, cited herein as P38.	X
	22	L- 022	N/A	U.S. Appl. No. 09/594,719, filed Jun. 16, 2000, entitled "Utilizing Data Reduction in Steganographic and Cryptographic Systems", published as 7,123,718 10-17-2006, cited herein as U255.	X
	23	L- 023	N/A	U.S. Appl. No. 11/519,467, filed Sep. 12, 2006, entitled "Utilizing Data Reduction in Steganographic and Cryptographic Systems", published as 2007-0064940 A1 03-22-2007, cited herein as P41.	X
	24	L- 024	N/A	U.S. Appl. No. 09/731,040, filed Dec. 7, 2000, entitled "Systems, Methods And Devices For Trusted Transactions", 2002-0010684 A1 01-24-2002, cited herein as P3.	X
	25	L- 025	N/A	U.S. Appl. No. 11/512,701, filed Aug. 29, 2006, entitled "Systems, Methods And Devices For Trusted Transactions", published as 2007-0028113 A1 02-01-2007, cited herein as P40.	X

DATE:	EXAMINER'S SIGNATURE:
-------	-----------------------

Printed: March 20, 2015 (12:02pm)

Path: Y:\Clients\SCOT Scott A Moskowitz and Wistaria Trading,

Inc\SCOT0014-4\Drafts\ReferenceCitationList_SCOT0014-4_3-12-2015.wpd

37 CFR 1.98(a)(1)(i) APPLICATION & ATTORNEY DOCKET: 11/895,388 / SCOT0014-4

37 CFR 1.98(a)(1)(iii): THIS IS AN INFORMATION DISCLOSURE STATEMENT

EXAMINER INITIAL	REF. NO. (L series)	REFERENCE NUMBER (L Series)	PUB. DATE	INCLUDE IN SEQUENCE: Name of first author (in CAPITAL LETTERS), Title in quotation marks, name of publication, date or publication, page numbers, publisher, city of publication, and country of publication NOTE - For US patent applications listed herein, if a	REFERENCES CITED AND CONSIDERED BY EXAMINER IN PARENT CASE IDENTIFIED BY PLACEMENT OF "X"
	26	L- 026	N/A	U.S. Appl. No. 10/049,101, filed Feb. 8, 2002, entitled "A Secure Personal Content Server", published as 7,475,246 01-06-2009, cited herein as U277.	X
	27	L- 027	N/A	PCT Application No. PCT/US00/21189, filed Aug. 4, 2000, entitled, "A Secure Personal Content Server", Pub. No.: WO/2001/018628 ; Publication Date: 15.03.2001, cited herein as F21.	X
	28	L- 028	N/A	U.S. Appl. No. 09/657,181, filed Sep. 7, 2000, entitled "Method and Device For Monitoring And Analyzing Signals", published as 7,346,472 03-18-2008, cited herein as U271.	X
	29	L- 029	N/A	U.S. Appl. No. 10/805,484, filed Mar. 22, 2004, entitled "Method And Device For Monitoring And Analyzing Signals", published as 2004-0243540 A1 12-02-2004, cited herein as P27.	X
	30	L- 030	N/A	U.S. Appl. No. 09/956,262, filed Sep. 20, 2001, entitled "Improved Security Based on Subliminal and Supraliminal Channels For Data Objects", published as 2002-0056041 A1 05-09-2002, cited herein as P05	X
	31	L- 031	N/A	U.S. Appl. No. 11/518,806, filed Sep. 11, 2006, entitled "Improved Security Based on Subliminal and Supraliminal Channels For Data Objects", 2008-0028222 A1 01-31-2008, cited herein as P57.	X
	32	L- 032	N/A	U.S. Appl. No. 11/026,234, filed Dec. 30, 2004, entitled "Z-Transform Implementation of Digital Watermarks" , published as 2005-0135615 A1 06-23-2005, cited herein as P28.	X
	33	L- 033	N/A	U.S. Appl. No. 11/592,079, filed Nov. 2, 2006, entitled "Linear Predictive Coding Implementation of Digital Watermarks", published as 2007-0079131 A1 04-05-2007, cited herein as P42.	X

DATE:	EXAMINER'S SIGNATURE:
-------	-----------------------

Printed: March 20, 2015 (12:02pm)

Path: Y:\Clients\SCOT Scott A Moskowitz and Wistaria Trading,

Inc\SCOT0014-4\Drafts\ReferenceCitationList_SCOT0014-4_3-12-2015.wpd

37 CFR 1.98(a)(1)(i) APPLICATION & ATTORNEY DOCKET: 11/895,388 / SCOT0014-4

37 CFR 1.98(a)(1)(iii): THIS IS AN INFORMATION DISCLOSURE STATEMENT

EXAMINER INITIAL	REF. NO. (L series)	REFERENCE NUMBER (L Series)	PUB. DATE	INCLUDE IN SEQUENCE: Name of first author (in CAPITAL LETTERS), Title in quotation marks, name of publication, date or publication, page numbers, publisher, city of publication, and country of publication NOTE - For US patent applications listed herein, if a	REFERENCES CITED AND CONSIDERED BY EXAMINER IN PARENT CASE IDENTIFIED BY PLACEMENT OF "X"
	34	L- 034	N/A	U.S. Appl. No. 09/731,039, filed Dec. 7, 2000, entitled "System and Methods for Permitting Open Access to Data Objects and for Securing Data within the Data Objects", published as 2002-0071556 A1 06-13-2002, cited herein as P06.	X
	35	L- 035	N/A	U.S. Appl. No. 11/647,861, filed Dec. 29, 2006, entitled "System and Methods for Permitting Open Access to Data Objects and for Securing Data within the Data Objects", published as 2007-0110240 A1 05-17-2007, cited herein as P44.	X
	36	L- 036	1996	Schneier, Bruce, Applied Cryptography, 2nd Ed., John Wiley & Sons, pp. 9-10, 1996.	X
	37	L- 037	1997	Menezes, Alfred J., Handbook of Applied Cryptography, CRC Press, p. 46, 1997.	X
	38	L- 038	1997	Merriam-Webster's Collegiate Dictionary, 10th Ed., Merriam Webster, Inc., p. 207.	X
	39	L- 039	1984	Brealy, et al., Principles of Corporate Finance, "Appendix A--Using Option Valuation Models", 1984, pp. 448-449.	X
	40	L- 040	2001	Copeland, et al., Real Options: A Practitioner's Guide, 2001 pp. 106-107, 201-202, 204-208.	X
	41	L- 041	1995	Sarkar, M. "An Assessment of Pricing Mechanisms for the Internet-A Regulatory Imperative", presented MIT Workshop on Internet Economics, Mar. 1995 http://www.press.vmich.edu/ieep/works/SarkAsses.html on.	X
	42	L- 042	1995	Crawford, D.W. "Pricing Network Usage: A Market for Bandwidth of Market Communication?" presented MIT Workshop on Internet Economics, Mar. 1995 http://www.press.vmich.edu/ieep/works/CrawMarket.html on March.	X
	43	L- 043	1988	Low, S.H., "Equilibrium Allocation and Pricing of Variable Resources Among User-Suppliers", 1988. http://www.citeseer.nj.nec.com/366503.html .	X

DATE:	EXAMINER'S SIGNATURE:
-------	-----------------------

Printed: March 20, 2015 (12:02pm)

Path: Y:\Clients\SCOT Scott A Moskowitz and Wistaria Trading,

Inc\SCOT0014-4\Drafts\ReferenceCitationList_SCOT0014-4_3-12-2015.wpd

37 CFR 1.98(a)(1)(i) APPLICATION & ATTORNEY DOCKET: 11/895,388 / SCOT0014-4

37 CFR 1.98(a)(1)(iii): THIS IS AN INFORMATION DISCLOSURE STATEMENT

EXAMINER INITIAL	REF. NO. (L series)	REFERENCE NUMBER (L Series)	PUB. DATE	INCLUDE IN SEQUENCE: Name of first author (in CAPITAL LETTERS), Title in quotation marks, name of publication, date or publication, page numbers, publisher, city of publication, and country of publication NOTE - For US patent applications listed herein, if a	REFERENCES CITED AND CONSIDERED BY EXAMINER IN PARENT CASE IDENTIFIED BY PLACEMENT OF "X"
	44	L- 044	1995	Caronni, Germano, "Assuring Ownership Rights for Digital Images", published proceeds of reliable IT systems, v15 '95, H.H. Bruggemann and W. Gerhardt-Hackel (Ed) Viewing Publishing Company Germany 1995.	X
	45	L- 045	1996	Zhao, Jian. "A WWW Service to Embed and Prove Digital Copyright Watermarks", Proc. of the European conf. on Multimedia Applications, Services & Techniques Louvain-La-Neuve Belgium May 1996.	X
	46	L- 046	1996	Gruhl, Daniel et al., Echo Hiding. In Proceeding of the Workshop on Information Hiding. No. 1174 in Lecture Notes in Computer Science, Cambridge, England (May/Jun. 1996).	X
	47	L- 047	1995	Oomen, A.W.J. et al., A Variable Bit Rate Buried Data Channel for Compact Disc, J.AudioEng. Sc., vol. 43, No. 1/2, pp. 23-28 (1995).	X
	48	L- 048	1992	Ten Kate, W. et al., A New Surround-Stereo-Surround Coding Techniques, J. Audio Eng.Soc., vol. 40,No. 5,pp. 376-383 (1992).	X
	49	L- 049	1993	Gerzon, Michael et al., A High Rate Buried Data Channel for Audio CD, presentation notes, Audio Engineering Soc. 94th Convention (1993).	X
	50	L- 050	1988	Sklar, Bernard, Digital Communications, pp. 601-603 (1988).	X
	51	L- 051	1984	Jayant, N.S. et al., Digital Coding of Waveforms, Prentice Hall Inc., Englewood Cliffs, NJ, pp. 486-509 (1984)	X
	52	L- 052	1995	Bender, Walter R. et al., Techniques for Data Hiding, SPIE Int. Soc. Opt. Eng., vol. 2420, pp. 164-173, 1995.	X
	53	L- 053	1995	Zhao, Jian et al., Embedding Robust Labels into Images for Copyright Protection, (xp 000571976), pp. 242-251, 1995.	X
	54	L- 054	1997	Menezes, Alfred J., Handbook of Applied Cryptography, CRC Press, p. 175, 1997.	X

DATE:	EXAMINER'S SIGNATURE:
-------	-----------------------

Printed: March 20, 2015 (12:02pm)

Path: Y:\Clients\SCOT Scott A Moskowitz and Wistaria Trading,

Inc\SCOT0014-4\Drafts\ReferenceCitationList_SCOT0014-4_3-12-2015.wpd

37 CFR 1.98(a)(1)(i) APPLICATION & ATTORNEY DOCKET: 11/895,388 / SCOT0014-4

37 CFR 1.98(a)(1)(iii): THIS IS AN INFORMATION DISCLOSURE STATEMENT

EXAMINER INITIAL	REF. NO. (L series)	REFERENCE NUMBER (L Series)	PUB. DATE	INCLUDE IN SEQUENCE: Name of first author (in CAPITAL LETTERS), Title in quotation marks, name of publication, date or publication, page numbers, publisher, city of publication, and country of publication NOTE - For US patent applications listed herein, if a	REFERENCES CITED AND CONSIDERED BY EXAMINER IN PARENT CASE IDENTIFIED BY PLACEMENT OF "X"
	55	L- 055	1994	Schneier, Bruce, Applied Cryptography, 1st Ed., pp. 67-68, 1994.	X
	56	L- 056	1990	Ten Kate, W. et al., "Digital Audio Carrying Extra Information", IEEE, CH 2847-2/90/0000-1097, (1990).	X
	57	L- 057	1994	Van Schyndel, et al., "A digital Watermark," IEEE Int'l Computer Processing Conference, Austin, TX, Nov. 13-16, 1994, pp. 86-90.	X
	58	L- 058	1996	Smith, et al. "Modulation and Information Hiding in Images", Springer Verlag, 1st Int'l Workshop, Cambridge, UK, May 30-Jun. 1, 1996, pp. 207-227.	X
	59	L- 059	1997	Kutter, Martin et al., "Digital Signature of Color Images Using Amplitude Modulation", SPIE-E197, vol. 3022, pp. 518-527.	X
	60	L- 060	1997	Puate, Joan et al., "Using Fractal Compression Scheme to Embed a Digital Signature into an Image", SPIE-96 Proceedings, vol. 2915, Mar. 1997, pp. 108-118.	X
	61	L- 061	1996	Swanson, Mitchell D., et al., "Transparent Robust Image Watermarking", Proc. of the 1996 IEEE Int'l Conf. on Image Processing, vol. 111, 1996, pp. 211-214.	X
	62	L- 062	1996	Swanson, Mitchell D., et al. "Robust Data Hiding for Images", 7th IEEE Digital Signal Processing Workshop, Leon, Norway. Sep. 1-4, 1996, pp. 37-40.	X
	63	L- 063	Unknown	Zhao, Jian et al., "Embedding Robust Labels into Images for Copyright Protection", Proceeding of the Know Right '95 Conference, pp. 242-251.	X
	64	L- 064	1995	Koch, E., et al., "Towards Robust and Hidden Image Copyright Labeling", 1995 IEEE Workshop on Nonlinear Signal and Image Processing, Jun. 1995 Neos Marmaras pp. 4.	X
	65	L- 065	1995	Van Schyndel, et al., "Towards a Robust Digital Watermark", Second Asian Image Processing Conference, Dec. 6-8, 1995, Singapore, vol. 2, pp. 504-508.	X

DATE:	EXAMINER'S SIGNATURE:
-------	-----------------------

Printed: March 20, 2015 (12:02pm)

Path: Y:\Clients\SCOT Scott A Moskowitz and Wistaria Trading,

Inc\SCOT0014-4\Drafts\ReferenceCitationList_SCOT0014-4_3-12-2015.wpd

37 CFR 1.98(a)(1)(i) APPLICATION & ATTORNEY DOCKET: 11/895,388 / SCOT0014-4

37 CFR 1.98(a)(1)(iii): THIS IS AN INFORMATION DISCLOSURE STATEMENT

EXAMINER INITIAL	REF. NO. (L series)	REFERENCE NUMBER (L Series)	PUB. DATE	INCLUDE IN SEQUENCE: Name of first author (in CAPITAL LETTERS), Title in quotation marks, name of publication, date or publication, page numbers, publisher, city of publication, and country of publication NOTE - For US patent applications listed herein, if a	REFERENCES CITED AND CONSIDERED BY EXAMINER IN PARENT CASE IDENTIFIED BY PLACEMENT OF "X"
	66	L- 066	1995	Tirkel,A.Z., "A Two-Dimensional Digital Watermark", DICTA '95, Univ. of Queensland, Brisbane, Dec. 5-8, 1995, pp. 7.	X
	67	L- 067	1996	Tirkel,A.Z., "Image Watermarking--A Spread Spectrum Application", ISSSTA '96, Sep. 1996, Mainz, German, pp. 6.	X
	68	L- 068	1996	O'Ruanaidh, et al. "Watermarking Digital Images for Copyright Protection", IEEE Proceedings, vol. 143, No. 4, Aug. 1996, pp. 250-256.	X
	69	L- 069	Unknown	Cox, et al., Secure Spread Spectrum Watermarking for Multimedia, NEC Research Institute, Techinal Report 95-10, pp. 33.	X
	70	L- 070	1969	Kahn, D., "The Code Breakers", The MacMillan Company, 1969, pp. xIII, 81-83, 513, 515, 522-526, 863.	X
	71	L- 071	1997	Boney, et al., Digital Watermarks for Audio Signals, EVSIPCO, 96, pp. 473-480 (3/14/1997).	X
	72	L- 072	1996	Dept. of Electrical Engineering, Del Ft University of Technology, Del ft The Netherlands, Cr.C. Langelaar et al., "Copy Protection for Multimedia Data based on Labeling Techniques", Jul. 1996 9 pp.	X
	73	L- 073	Unknown	F. Hartung, et al., "Digital Watermarking of Raw and Compressed Video", SPIE vol. 2952, pp. 205-213.	X
	74	L- 074	1996	Craver, et al., "Can Invisible Watermarks Resolve Rightful Ownerships?", IBM Research Report, RC 20509 (Jul. 25, 1996) 21 pp.	X
	75	L- 075	1988	Press, et al., "Numerical Recipes in C", Cambridge Univ. Press, 1988, pp. 398-417.	X
	76	L- 076	1995	Pohlmann, Ken C., "Principles of Digital Audio", 3rd Ed., 1995, pp. 32-37, 40-48:138, 147-149, 332, 333, 364, 499-501, 508-509, 564-571.	X
	77	L- 077	1991	Pohlmann, Ken C., "Principles of Digital Audio", 2nd Ed., 1991, pp. 1-9, 19-25, 30-33, 41-48, 54-57, 86-107, 375-387.	X

DATE:	EXAMINER'S SIGNATURE:
-------	-----------------------

Printed: March 20, 2015 (12:02pm)

Path: Y:\Clients\SCOT Scott A Moskowitz and Wistaria Trading,

Inc\SCOT0014-4\Drafts\ReferenceCitationList_SCOT0014-4_3-12-2015.wpd

37 CFR 1.98(a)(1)(i) APPLICATION & ATTORNEY DOCKET: 11/895,388 / SCOT0014-4

37 CFR 1.98(a)(1)(iii): THIS IS AN INFORMATION DISCLOSURE STATEMENT

EXAMINER INITIAL	REF. NO. (L series)	REFERENCE NUMBER (L Series)	PUB. DATE	INCLUDE IN SEQUENCE: Name of first author (in CAPITAL LETTERS), Title in quotation marks, name of publication, date or publication, page numbers, publisher, city of publication, and country of publication NOTE - For US patent applications listed herein, if a	REFERENCES CITED AND CONSIDERED BY EXAMINER IN PARENT CASE IDENTIFIED BY PLACEMENT OF "X"
	78	L- 078	1994	Schneier, Bruce, Applied Cryptography, John Wiley & Sons, Inc., New York, 1994, pp. 68, 69, 387-392, 1-57, 273-275, 321-324.	X
	79	L- 079	1996	Boney, et al., Digital Watermarks for Audio Signals, Proceedings of the International Conf. on Multimedia Computing and Systems, Jun. 17-23, 1996 Hiroshima, Japan, 0-8186-7436-9196, pp. 473-480.	X
	80	L- 080	1998	Johnson, et al., "Transform Permuted Watermarking for Copyright Protection of Digital Video", IEEE Globecom 1998, Nov. 8-12, 1998, New York New York vol. 2 1998 pp. 684-689 (ISBN 0-7803-4985-7).	X
	81	L- 081	1996	Rivest, et al., "Pay Word and Micromint: Two Simple Micropayment Schemes," MIT Laboratory for Computer Science, Cambridge, MA, May 7, 1996 pp. 1-18.	X
	82	L- 082	1996	Bender, et al., "Techniques for Data Hiding", IBM Systems Journal, (1996) vol. 35, Nos. 3 & 4, 1996, pp. 313-336.	X
	83	L- 083	2003	Moskowitz, "Bandwith as Currency", IEEE Multimedia, Jan.-Mar. 2003, pp. 14-21.	X
	84	L- 084	2006	Moskowitz, Multimedia Security Technologies for Digital Rights Management, 2006, Academic Press, "Introduction--Digital Rights Management" pp. 3-22.	X
	85	L- 085	2001	Rivest, et al., "PayWord and Micromint: Two Simple Micropayment Schemes," MIT Laboratory for Computer Science, Cambridge, MA, Apr. 27, 2001, pp. 1-18.	X
	86	L- 086	2000	Tomsich, et al., "Towards a secure and de-centralized digital watermarking infrastructure for the protection of Intellectual Property", in Electronic Commerce and Web Technologies, Proceedings (ECWEB)(2000).	X
	87	L- 087	2002	Moskowitz, "What is Acceptable Quality in the Application of Digital Watermarking: Trade-offs of Security; Robustness and Quality", IEEE Computer Society Proceedings of ITCC 2002 Apr. 10, 2002 pp. 80-84.	X

DATE:	EXAMINER'S SIGNATURE:
-------	-----------------------

Printed: March 20, 2015 (12:02pm)

Path: Y:\Clients\SCOT Scott A Moskowitz and Wistaria Trading,

Inc\SCOT0014-4\Drafts\ReferenceCitationList_SCOT0014-4_3-12-2015.wpd

37 CFR 1.98(a)(1)(i) APPLICATION & ATTORNEY DOCKET: 11/895,388 / SCOT0014-4

37 CFR 1.98(a)(1)(iii): THIS IS AN INFORMATION DISCLOSURE STATEMENT

EXAMINER INITIAL	REF. NO. (L series)	REFERENCE NUMBER (L Series)	PUB. DATE	INCLUDE IN SEQUENCE: Name of first author (in CAPITAL LETTERS), Title in quotation marks, name of publication, date or publication, page numbers, publisher, city of publication, and country of publication NOTE - For US patent applications listed herein, if a	REFERENCES CITED AND CONSIDERED BY EXAMINER IN PARENT CASE IDENTIFIED BY PLACEMENT OF "X"
	88	L- 088	2006	Lemma, et al. "Secure Watermark Embedding through Partial Encryption", International Workshop on Digital Watermarking ("IWDW" 2006). Springer Lecture Notes in Computer Science 2006 (to appear) 13.	X
	89	L- 089	2002	Kocher, et al., "Self Protecting Digital Content", Technical Report from the CRI Content Security Research Initiative, Cryptography Research, Inc. 2002-2003 14 pages.	X
	90	L- 090	1995	Sirbu, M. et al., "Net Bill: An Internet Commerce System Optimized for Network Delivered Services", Digest of Papers of the Computer Society Computer Conference (Spring) Mar. 5, 1995 pp. 20-25 vol. CONF40.	X
	91	L- 091	1998	Schunter, M. et al., "A Status Report on the SEMPER framework for Secure Electronic Commerce", Computer Networks and ISDN Systems, Sep. 30, 1998, pp. 1501-1510 vol. 30 No. 16-18 NL North Holland.	X
	92	L- 092	1999	Konrad, K. et al., "Trust and Electronic Commerce--more than a technical problem," Proceedings of the 18th IEEE Symposium on Reliable Distributed Systems Oct. 19-22, 1999, pp. 360-365 Lausanne.	X
	93	L- 093	1998	Kini, et al., "Trust in Electronic Commerce: Definition and Theoretical Considerations", Proceedings of the 31st Hawaii Int'l Conf on System Sciences (Cat. No. 98TB100216). Jan. 6-9, 1998. pp. 51-61. Los.	X
	94	L- 094	1997	Steinauer D. D., et al., "Trust and Traceability in Electronic Commerce", Standard View, Sep. 1997, pp. 118-124, vol. 5 No. 3, ACM, USA.	X
	95	L- 095	1999	Hartung, et al. "Multimedia Watermarking Techniques", Proceedings of the IEEE, Special Issue, Identification & Protection of Multimedia Information, pp. 1079-1107 Jul. 1999 vol. 87 No. 7 IEEE.	X
	96	L- 096	N/A	European Search Report & European Search Opinion in EP07112420	X
	97	L- 097	2006	STAIND (The Singles 1996-2006), Warner Music--Atlantic, Pre-Release CD image, 2006, 1 page.	X

DATE:	EXAMINER'S SIGNATURE:
-------	-----------------------

Printed: March 20, 2015 (12:02pm)

Path: Y:\Clients\SCOT Scott A Moskowitz and Wistaria Trading,

Inc\SCOT0014-4\Drafts\ReferenceCitationList_SCOT0014-4_3-12-2015.wpd

37 CFR 1.98(a)(1)(i) APPLICATION & ATTORNEY DOCKET: 11/895,388 / SCOT0014-4

37 CFR 1.98(a)(1)(iii): THIS IS AN INFORMATION DISCLOSURE STATEMENT

EXAMINER INITIAL	REF. NO. (L series)	REFERENCE NUMBER (L Series)	PUB. DATE	INCLUDE IN SEQUENCE: Name of first author (in CAPITAL LETTERS), Title in quotation marks, name of publication, date or publication, page numbers, publisher, city of publication, and country of publication NOTE - For US patent applications listed herein, if a	REFERENCES CITED AND CONSIDERED BY EXAMINER IN PARENT CASE IDENTIFIED BY PLACEMENT OF "X"
	98	L- 098		DUPLICATE OF L-97, DELETED BY 11/16/2010 by RAN.	X
	99	L- 099	2003	Radiohead ("Hail To The Thief"), EMI Music Group--Capitol, Pre-Release CD image, 2003, 1 page.	X
	100	L- 0100	N/A	DUPLICATE OF L-4, DELETED BY RN UPON REVIEW ON 11/18/2010. RAN	X
	101	L- 0101	N/A	U.S. Appl. No. 60/169,274, filed Dec. 7, 1999, entitled "Systems, Methods And Devices For Trusted Transactions".	X
	102	L- 0102		DUPLICATE OF L-22, DELETED BY RN UPON REVIEW ON 11/16/2010. RAN	X
	103	L- 0103		DUPLICATE OF L-27, DELETED BY RN UPON REVIEW ON 11/16/2010. RAN	X
	104	L- 0104	N/A	U.S. Appl. No. 60/234,199, filed Sep. 20, 2000, "Improved Security Based on Subliminal and Supraliminal Channels For Data Objects".	X
	105	L- 0105	N/A	U.S. Appl. No. 09/671,739, filed Sep. 29, 2000, entitled "Method And Device For Monitoring And Analyzing Signals".	X
	106	L- 0106		DUPLICATE OF L-34, DELETED BY RN UPON REVIEW ON 11/16/2010. RAN	X
	107	L- 0107		DUPLICATE OF L-24, DELETED BY RN UPON REVIEW ON 11/16/2010. RAN	X
	108	L- 0108		DUPLICATE OF L-57, DELETED BY RN UPON REVIEW ON 11/16/2010. RAN	X
	109	L- 0109		DUPLICATE OF L-58, DELETED BY RN UPON REVIEW ON 11/16/2010. RAN	X
	110	L- 0110		DUPLICATE OF L-59, DELETED BY RN UPON REVIEW ON 11/16/2010. RAN	X
	111	L- 0111		DUPLICATE OF L-61, DELETED BY RN UPON REVIEW ON 11/16/2010. RAN	X

DATE:	EXAMINER'S SIGNATURE:
-------	-----------------------

Printed: March 20, 2015 (12:02pm)

Path: Y:\Clients\SCOT Scott A Moskowitz and Wistaria Trading,

Inc\SCOT0014-4\Drafts\ReferenceCitationList_SCOT0014-4_3-12-2015.wpd

37 CFR 1.98(a)(1)(i) APPLICATION & ATTORNEY DOCKET: 11/895,388 / SCOT0014-4

37 CFR 1.98(a)(1)(iii): THIS IS AN INFORMATION DISCLOSURE STATEMENT

EXAMINER INITIAL	REF. NO. (L series)	REFERENCE NUMBER (L Series)	PUB. DATE	INCLUDE IN SEQUENCE: Name of first author (in CAPITAL LETTERS), Title in quotation marks, name of publication, date or publication, page numbers, publisher, city of publication, and country of publication NOTE - For US patent applications listed herein, if a	REFERENCES CITED AND CONSIDERED BY EXAMINER IN PARENT CASE IDENTIFIED BY PLACEMENT OF "X"
	112	L- 0112		DUPLICATE OF L-62, DELETED BY RN UPON REVIEW ON 11/16/2010. RAN	X
	113	L- 0113		DUPLICATE OF L-63, DELETED BY RN UPON REVIEW ON 11/16/2010. RAN	X
	114	L- 0114		DUPLICATE OF L-65, DELETED BY RN UPON REVIEW ON 11/16/2010. RAN	X
	115	L- 0115	Unknown	Tirkel, A.Z., "A Two-Dimensional Digital Watermark", Scientific Technology, 686, 14, date unknown. (citation revised upon review on 11/16/10 by RAN.)	X
	116	L- 0116		DUPLICATE OF L-65, DELETED BY RN UPON REVIEW ON 11/16/2010. RAN	X
	117	L- 0117		DUPLICATE OF L-68, DELETED BY RN UPON REVIEW ON 11/16/2010. RAN	X
	118	L- 0118		DUPLICATE OF L-69, DELETED BY RN UPON REVIEW ON 11/16/2010. RAN	X
	119	L- 0119		DUPLICATE OF L-70, DELETED BY RN UPON REVIEW ON 11/16/2010. RAN	X
	120	L- 0120		DUPLICATE OF L-71, DELETED BY RN UPON REVIEW ON 11/16/2010. RAN	X
	121	L- 0121		DUPLICATE OF L-72, DELETED BY RN UPON REVIEW ON 11/16/2010. RAN	X
	122	L- 0122		DUPLICATE OF L-73, DELETED BY RN UPON REVIEW ON 11/16/2010. RAN	X
	123	L- 0123		DUPLICATE OF L-74, DELETED BY RN UPON REVIEW ON 11/16/2010. RAN	X
	124	L- 0124		DUPLICATE OF L-75, DELETED BY RN UPON REVIEW ON 11/16/2010. RAN	X
	125	L- 0125		DUPLICATE OF L-076, REMOVED. RN. 11/16/2010	X
	126	L- 0126		DUPLICATE OF L-77, REMOVED. RN. 11/16/2010	X

DATE:	EXAMINER'S SIGNATURE:
-------	-----------------------

Printed: March 20, 2015 (12:02pm)

Path: Y:\Clients\SCOT Scott A Moskowitz and Wistaria Trading,

Inc\SCOT0014-4\Drafts\ReferenceCitationList_SCOT0014-4_3-12-2015.wpd

37 CFR 1.98(a)(1)(i) APPLICATION & ATTORNEY DOCKET: 11/895,388 / SCOT0014-4

37 CFR 1.98(a)(1)(iii): THIS IS AN INFORMATION DISCLOSURE STATEMENT

EXAMINER INITIAL	REF. NO. (L series)	REFERENCE NUMBER (L Series)	PUB. DATE	INCLUDE IN SEQUENCE: Name of first author (in CAPITAL LETTERS), Title in quotation marks, name of publication, date or publication, page numbers, publisher, city of publication, and country of publication NOTE - For US patent applications listed herein, if a	REFERENCES CITED AND CONSIDERED BY EXAMINER IN PARENT CASE IDENTIFIED BY PLACEMENT OF "X"
	127	L- 0127		DUPLICATE OF L-78, REMOVED. RN. 11/16/2010	X
	128	L- 0128		DUPLICATE OF L-79, REMOVED. RN. 11/16/2010	X
	129	L- 0129		EP0581317A2, MOVED TO FOREIGN PATENT PUBS as F-028	X
	130	L- 0130		DUPLICATE OF L-52, REMOVED. RN. 11/16/2010	X
	131	L- 0131		DUPLICATE OF L-36, REMOVED. RN. 11/16/2010	X
	132	L- 0132		DUPLICATE OF L-38, REMOVED. RN. 11/16/2010.	X
	133	L- 0133		DUPLICATE OF L-37, REMOVED. RN. 11/16/2010	X
	134	L- 0134		DUPLICATE OF L-36, REMOVED. RN. 11/16/2010	X
	135	L- 0135		DUPLICATE OF L-37, REMOVED. RN. 11/16/2010	X
	136	L- 0136		DUPLICATE OF L-38, REMOVED. RN. 11/16/2010	X
	137	L- 0137		DUPLICATE OF L-39, REMOVED. RN. 11/16/2010	X
	138	L- 0138		DUPLICATE OF L-40, REMOVED. RN. 11/16/2010	X
	139	L- 0139		DUPLICATE OF L-41, REMOVED. RN. 11/16/2010	X
	140	L- 0140		DUPLICATE OF L-42, REMOVED. RN. 11/16/2010	X
	141	L- 0141		DUPLICATE OF L-43, REMOVED. RN. 11/16/2010	X
	142	L- 0142		DUPLICATE OF L-44, REMOVED. RN. 11/16/2010	X
	143	L- 0143		DUPLICATE OF L-45, REMOVED. RN. 11/16/2010.	X
	144	L- 0144		DUPLICATE OF L-46, REMOVED. RN. 11/16/2010.	X
	145	L- 0145		DUPLICATE OF L-47, REMOVED. RN. 11/16/2010	X
	146	L- 0146		DUPLICATE OF L-48, REMOVED. RN. 11/16/2010	X

DATE:	EXAMINER'S SIGNATURE:
-------	-----------------------

Printed: March 20, 2015 (12:02pm)

Path: Y:\Clients\SCOT Scott A Moskowitz and Wistaria Trading,

Inc\SCOT0014-4\Drafts\ReferenceCitationList_SCOT0014-4_3-12-2015.wpd

37 CFR 1.98(a)(1)(i) APPLICATION & ATTORNEY DOCKET: 11/895,388 / SCOT0014-4

37 CFR 1.98(a)(1)(iii): THIS IS AN INFORMATION DISCLOSURE STATEMENT

EXAMINER INITIAL	REF. NO. (L series)	REFERENCE NUMBER (L Series)	PUB. DATE	INCLUDE IN SEQUENCE: Name of first author (in CAPITAL LETTERS), Title in quotation marks, name of publication, date or publication, page numbers, publisher, city of publication, and country of publication NOTE - For US patent applications listed herein, if a	REFERENCES CITED AND CONSIDERED BY EXAMINER IN PARENT CASE IDENTIFIED BY PLACEMENT OF "X"
	147	L- 0147		DUPLICATE OF L-49, REMOVED. RN. 11/16/2010	X
	148	L- 0148		DUPLICATE OF L-50, REMOVED. RN. 11/16/2010	X
	149	L- 0149		DUPLICATE OF L-51, REMOVED. RN. 11/16/2010	X
	150	L- 0150		DUPLICATE OF L-52, REMOVED. RN. 11/16/2010	X
	151	L- 0151		DUPLICATE OF L-63, REMOVED. RN. 11/16/2010	X
	152	L- 0152		DUPLICATE OF L-54, REMOVED. RN. 11/16/2010	X
	153	L- 0153		DUPLICATE OF L-55, REMOVED. RN. 11/16/2010.	X
	154	L- 0154		DUPLICATE OF L-80, REMOVED. RN. 11/16/2010.	X
	155	L- 0155	N/A	PCT International Search Report in PCT/US95/08159.	X
	156	L- 0156	N/A	PCT International Search Report in PCT/US96/10257.	X
	157	L- 0157	N/A	Supplementary European Search Report in EP 96919405.	X
	158	L- 0158	N/A	PCT International Search Report in PCT/US97/00651.	X
	159	L- 0159	N/A	PCT International Search Report in PCT/US97/00652	X
	160	L- 0160	N/A	PCT International Search Report in PCT/US97/11455.	X
	161	L- 0161		PCT International Search Report in PCT/US99/07262.	X
	162	L- 0162		PCT International Search Report in PCT/US00/06522	X
	163	L- 0163		Supplementary European Search Report in EP00919398	X
	164	L- 0164		PCT International Search Report in PCT/US00/18411.	X
	165	L- 0165		PCT International Search Report in PCT/US00/18411.	X
	166	L- 0166		PCT International Search Report in PCT/US00/33126	X
	167	L- 0167		PCT International Search Report in PCT/US00/21189	X
	168	L- 0168		Delaigle, J.-F., et al. "Digital Watermarking," Proceedings of the SPIE, vol. 2659, Feb 1, 1996, pp. 99-110.	X

DATE:	EXAMINER'S SIGNATURE:
-------	-----------------------

Printed: March 20, 2015 (12:02pm)

Path: Y:\Clients\SCOT Scott A Moskowitz and Wistaria Trading,

Inc\SCOT0014-4\Drafts\ReferenceCitationList_SCOT0014-4_3-12-2015.wpd

37 CFR 1.98(a)(1)(i) APPLICATION & ATTORNEY DOCKET: 11/895,388 / SCOT0014-4

37 CFR 1.98(a)(1)(iii): THIS IS AN INFORMATION DISCLOSURE STATEMENT

EXAMINER INITIAL	REF. NO. (L series)	REFERENCE NUMBER (L Series)	PUB. DATE	INCLUDE IN SEQUENCE: Name of first author (in CAPITAL LETTERS), Title in quotation marks, name of publication, date or publication, page numbers, publisher, city of publication, and country of publication NOTE - For US patent applications listed herein, if a	REFERENCES CITED AND CONSIDERED BY EXAMINER IN PARENT CASE IDENTIFIED BY PLACEMENT OF "X"
	169	L- 0169	1996	Schneider, M., et al. "A Robust Content Based Digital Signature for Image Authentication," Proceedings of the International Conference on Image Processing (IC. Lausanne) Sep. 16-19, 1996, pp. 227-230, IEEE ISBN.	X
	170	L- 0170	1997	Cox, I. J., et al. "Secure Spread Spectrum Watermarking for Multimedia," IEEE Transactions on Image Processing, vol. 6 No. 12, Dec. 1, 1997, pp. 1673-1686.	X
	171	L- 0171	1998	Wong, Ping Wah. "A Public Key Watermark for Image Verification and Authentication," IEEE International Conference on Image Processing, vol. 1 Oct. 4-7, 1998, pp. 455-459.	X
	172	L- 0172	1998	Fabien A.P. Petitcolas, Ross J. Anderson and Markkus G. Kuhn, "Attacks on Copyright Marking Systems," LNCS, vol. 1525, Apr. 14-17, 1998, pp. 218-238 ISBN: 3-540-65386-4.	X
	173	L- 0173	1996	Ross Anderson, "Stretching the Limits of Steganography," LNCS, vol. 1174, May/Jun. 1996, 10 pages, ISBN: 3-540-61996-8.	X
	174	L- 0174	1997	Joseph J.K. O'Ruanaidh and Thierry Pun, "Rotation, Scale and Translation Invariant Digital Image Watermarking", pre-publication, Summer 1997 4 pages.	X
	175	L- 0175	1997	Joseph J.K. O'Ruanaidh and Thierry Pun, "Rotation, Scale and Translation Invariant Digital Image Watermarking", Submitted to Signal Processing Aug. 21, 1997, 19 pages.	X
	176	L- 0176	2008	OASIS (Dig Out Your Soul), Big Brother Recordings Ltd, Promotional CD image, 2008, 1 page.	X
	177	L- 0177	1998	Rivest, R. "Chaffing and Winnowing: Confidentiality without Encryption", MIT Lab for Computer Science, http://people.csail.mit.edu/rivest/Chaffing.txt Apr. 24, 1998, 9 pp.	X
	178	L- 0178	2003	PortalPlayer, PP5002 digital media management system-on-chip, May 1, 2003, 4 pp.	X

DATE:	EXAMINER'S SIGNATURE:
-------	-----------------------

Printed: March 20, 2015 (12:02pm)

Path: Y:\Clients\SCOT Scott A Moskowitz and Wistaria Trading,

Inc\SCOT0014-4\Drafts\ReferenceCitationList_SCOT0014-4_3-12-2015.wpd

37 CFR 1.98(a)(1)(i) APPLICATION & ATTORNEY DOCKET: 11/895,388 / SCOT0014-4

37 CFR 1.98(a)(1)(iii): THIS IS AN INFORMATION DISCLOSURE STATEMENT

EXAMINER INITIAL	REF. NO. (L series)	REFERENCE NUMBER (L Series)	PUB. DATE	INCLUDE IN SEQUENCE: Name of first author (in CAPITAL LETTERS), Title in quotation marks, name of publication, date or publication, page numbers, publisher, city of publication, and country of publication NOTE - For US patent applications listed herein, if a	REFERENCES CITED AND CONSIDERED BY EXAMINER IN PARENT CASE IDENTIFIED BY PLACEMENT OF "X"
	179	L- 0179	2001	VeriDisc, "The Search for a Rational Solution to Digital Rights Management (DRM)", http://64.244.235.240/news/whitepaper./docs/veridisc.sub.--white.sub.--paper.pdf , 2001, 15 pp.	X
	180	L- 0180	2008	Cayre, et al., "Kerckhoff's-Based Embedding Security Classes for WOA Data Hiding", IEEE Transactions on Information Forensics and Security, vol. 3 No. 1, Mar. 2008, 15 pp.	X
	181	L- 0181	1999	Wayback Machine, dated Jan. 17, 1999, http://web.archive.org/web/19990117020420/http://www.netzero.com/ , accessed on Feb. 19, 2008.	X
	182	L- 0182	1997	Namgoong, H., "An Integrated Approach to Legacy Data for Multimedia Applications", Proceedings of the 23rd EUROMICRO Conference, vol., Issue 1-4, Sep. 1997, pp. 387-391.	X
	183	L- 0183	2007	Wayback Machine, dated Aug. 26, 2007, http://web.archive.org/web/20070826151732/http://www.screenplaysmag.com/t-abid/96/articleType/ArticleView/articleId/495/Default.aspx/ .	X
	184	L- 0184	2009	"YouTube Copyright Policy: Video Identification tool--YouTube Help", accessed Jun. 4, 2009, http://www.google.com/support/youtube/bin/answer.py?hl=en&answer=83766 , 3 pp.	X
	185	L- 0185	N/A	U.S. Appl. No. 12/665,002, filed Dec. 22, 2009, entitled "Method for Combining Transfer Function with Predetermined Key Creation", published as 20100182570 A1 07-22-2010, P76.	X
	186	L- 0186	N/A	U.S. Appl. No. 12/592,331, filed Nov. 23, 2009, entitled "Optimization Methods for the Insertion, Protection, and Detection of Digital Watermarks in Digital Data", published as 20100077220 A1 03-25-2010, P77.	X
	187	L- 0187	N/A	U.S. Appl. No. 12/590,553, filed Nov. 10, 2009, entitled "Optimization Methods for the Insertion, Protection, and Detection of Digital Watermarks in Digital Data", published as 20100077219 A1 03-25-2010, P78.	X

DATE:	EXAMINER'S SIGNATURE:
-------	-----------------------

Printed: March 20, 2015 (12:02pm)

Path: Y:\Clients\SCOT Scott A Moskowitz and Wistaria Trading,

Inc\SCOT0014-4\Drafts\ReferenceCitationList_SCOT0014-4_3-12-2015.wpd

37 CFR 1.98(a)(1)(i) APPLICATION & ATTORNEY DOCKET: 11/895,388 / SCOT0014-4

37 CFR 1.98(a)(1)(iii): THIS IS AN INFORMATION DISCLOSURE STATEMENT

EXAMINER INITIAL	REF. NO. (L series)	REFERENCE NUMBER (L Series)	PUB. DATE	INCLUDE IN SEQUENCE: Name of first author (in CAPITAL LETTERS), Title in quotation marks, name of publication, date or publication, page numbers, publisher, city of publication, and country of publication NOTE - For US patent applications listed herein, if a	REFERENCES CITED AND CONSIDERED BY EXAMINER IN PARENT CASE IDENTIFIED BY PLACEMENT OF "X"
	188	L- 0188	N/A	U.S. Appl. No. 12/590,681, filed Nov. 12, 2009, entitled "Optimization Methods for the Insertion, Protection, and Detection of Digital Watermarks in Digital Data", published as 20100064140 A1 03-11-2010, P79.	X
	189	L- 0189	N/A	U.S. Appl. No. 12/655,036, filed Dec. 22, 2009, entitled "Utilizing Data Reduction in Steganographic and Cryptographic Systems", published as 20100153734 A1 06-17-2010, P80 .	X
	190	L- 0190	N/A	U.S. Appl. No. 12/655,357, filed Dec. 22, 2009, entitled "Method And Device For Monitoring And Analyzing Signals", published as 20100106736 A1 04-29-2010, P81.	X
	191	L- 0191	N/A	PCT Application No. PCT/US95/08159, filed Jun. 26, 1995, entitled, "Digital Information Commodities Exchange with Virtual Menuing", published as WO/1997/001892; Publication Date: 16.01.1997, F24.	X
	192	L- 0192	N/A	PCT Application No. PCT/US96/10257, filed Jun. 7, 1996, entitled "Steganographic Method and Device"--corresponding to--EPO Application No. 96919405.9, entitled "Steganographic Method and Device", published as WO/1996/042151; Publication Date: 27.12.1996; F19.	X
	193	L- 0193	N/A	PCT Application No. PCT/US97/00651, filed Jan. 16, 1997, entitled, "Method for Stega-Cipher Protection of Computer Code", published as WO/1997/026732; Publication Date: 24.07.1997.	X
	194	L- 0194	N/A	PCT Application No. PCT/US97/00652, filed Jan. 17, 1997, entitled, "Method for an Encrypted Digital Watermark", published as WO/1997/026733; Publication Date: 24.07.1997	X
	195	L- 0195	N/A	PCT Application No. PCT/US97/11455, filed Jul. 2, 1997, entitled, "Optimization Methods for the Insertion, Protection and Detection of Digital Watermarks in Digitized Data", published as WO/1998/002864; Publication Date: 22.01.1998	X

DATE:	EXAMINER'S SIGNATURE:
-------	-----------------------

Printed: March 20, 2015 (12:02pm)

Path: Y:\Clients\SCOT Scott A Moskowitz and Wistaria Trading,

Inc\SCOT0014-4\Drafts\ReferenceCitationList_SCOT0014-4_3-12-2015.wpd

37 CFR 1.98(a)(1)(i) APPLICATION & ATTORNEY DOCKET: 11/895,388 / SCOT0014-4

37 CFR 1.98(a)(1)(iii): THIS IS AN INFORMATION DISCLOSURE STATEMENT

EXAMINER INITIAL	REF. NO. (L series)	REFERENCE NUMBER (L Series)	PUB. DATE	INCLUDE IN SEQUENCE: Name of first author (in CAPITAL LETTERS), Title in quotation marks, name of publication, date or publication, page numbers, publisher, city of publication, and country of publication NOTE - For US patent applications listed herein, if a	REFERENCES CITED AND CONSIDERED BY EXAMINER IN PARENT CASE IDENTIFIED BY PLACEMENT OF "X"
	196	L- 0196	N/A	PCT Application No. PCT/US99/07262, filed Apr. 2, 1999, entitled, "Multiple Transform Utilization and Applications for Secure Digital Watermarking", published as WO/1999/052271; Publication Date: 14.10.1999.	X
	197	L- 0197	N/A	PCT Application No. PCT/US00/06522, filed Mar. 14, 2000, entitled, "Utilizing Data Reduction in Steganographic and Cryptographic Systems", published as WO/2000/057643; Publication Date: 28.09.2000.	X
	198	L- 0198	N/A	PCT Application No. PCT/US00/18411, filed Jul. 5, 2000, entitled, "Copy Protection of Digital Data Combining Steganographic and Cryptographic Techniques"	X
	199	L- 0199	N/A	PCT Application No. PCT/US00/33126, filed Dec. 7, 2000, entitled "Systems, Methods and Devices for Trusted Transactions", published as WO/2001/043026; Publication Date: 14.06.2001.	X
	200	L- 0200	N/A	EPO Divisional Patent Application No. 07112420.0, entitled "Steganographic Method and Device" corresponding to PCT Application No. PCT/US96/10257, published as WO/1996/042151, 12/27/1996, cited herein above as F019.	X
	201	L- 0201	N/A	US Provisional Application 60/222,023 filed July 31, 2007 entitled "Method and apparatus for recognizing sound and signals in high noise and distortion"	X
	202	L- 0202	N/A	US Application 11/458,639 filed July 19, 2006 entitled "Methods and Systems for Inserting Watermarks in Digital Signals", published as 20060251291 A1 11-09-2006, P82.	X
	203	L- 0203	1995	"Techniques for Data Hiding in Audio Files," by Morimoto, 1995	X
	204	L- 0204	1998	Howe, Dennis July 13, 1998 http://foi.doc.org/steganography	X
	205	L- 0205	N/A	CSG, Computer Support Group and CSGNetwork.com 1973 http://www.csgnetwork.com/glossarys.html	X

DATE:	EXAMINER'S SIGNATURE:
-------	-----------------------

Printed: March 20, 2015 (12:02pm)

Path: Y:\Clients\SCOT Scott A Moskowitz and Wistaria Trading,

Inc\SCOT0014-4\Drafts\ReferenceCitationList_SCOT0014-4_3-12-2015.wpd

37 CFR 1.98(a)(1)(i) APPLICATION & ATTORNEY DOCKET: 11/895,388 / SCOT0014-4

37 CFR 1.98(a)(1)(iii): THIS IS AN INFORMATION DISCLOSURE STATEMENT

EXAMINER INITIAL	REF. NO. (L series)	REFERENCE NUMBER (L Series)	PUB. DATE	INCLUDE IN SEQUENCE: Name of first author (in CAPITAL LETTERS), Title in quotation marks, name of publication, date or publication, page numbers, publisher, city of publication, and country of publication NOTE - For US patent applications listed herein, if a	REFERENCES CITED AND CONSIDERED BY EXAMINER IN PARENT CASE IDENTIFIED BY PLACEMENT OF "X"
	206	L- 0206	2010	QuinStreet Inc. 2010 What is steganography?-A word definition from the Webopedia Computer Dictionary http://www.webopedia.com/terms/steganography.html	X
	207	L- 0207	2000	Graham, Robert August 21, 2000 "Hacking Lexicon" http://robertgraham.com/pubs/hacking-dict.html	X
	208	L- 0208	2010	Farkex, Inc 2010 "Steganography definition of steganography in the Free Online Encyclopedia" http://encyclopedia2.thefreedictionary.com/steganography	X
	209	L- 0209	1989	Horowitz, et al., The Art of Eletronics. 2 nd Ed., 1989, pp7	X
	210	L- 0210	2004	Jimmy eat world ("futures"), Interscope Records, Pre-Release CD image, 2004, 1 page.	X
	211	L- 0211	2001	Aerosmith ("Just Push Play"), Pre-Release CD image, 2001, 1 page.	X
	212	L- 0212	2002	Phil Collins(Testify) Atlantic, Pre-Release CD image, 2002, 1 page.	X
	213	L- 0213	1998	U. are U. Reviewer's Guide (U are U Software, 1998)	
	214	L- 0214	1998	U. are U. wins top honors! - Marketing Flyer (U. are U. Software, 1998).	
	215	L- 0215	1998	Digital Persona, Inc., <u>U. are U. Fingerprint Recognition System: User Guide</u> (Version 1.0, 1998).	
	216	L- 0216	1998	Digital Persona White Paper pp 8-9 published April 15, 1998.	
	217	L- 0217	2000	Digital Persona, Inc., "Digital Persona Releases U. are. U Pro Fingerprint Security Systems for Windows NT, 2000, '98, '95", (2000, February)	
	218	L- 0218	2011	SonicWall, Inc. 2011 "The Network Security SonicOS Platform-Deep Packet Inspection" http://www.sonicwall.com/us/en/products/Deep_Packet_Inspection.html	

DATE:	EXAMINER'S SIGNATURE:
-------	-----------------------

Printed: March 20, 2015 (12:02pm)

Path: Y:\Clients\SCOT Scott A Moskowitz and Wistaria Trading,

Inc\SCOT0014-4\Drafts\ReferenceCitationList_SCOT0014-4_3-12-2015.wpd

37 CFR 1.98(a)(1)(i) APPLICATION & ATTORNEY DOCKET: 11/895,388 / SCOT0014-4

37 CFR 1.98(a)(1)(iii): THIS IS AN INFORMATION DISCLOSURE STATEMENT

EXAMINER INITIAL	REF. NO. (L series)	REFERENCE NUMBER (L Series)	PUB. DATE	INCLUDE IN SEQUENCE: Name of first author (in CAPITAL LETTERS), Title in quotation marks, name of publication, date or publication, page numbers, publisher, city of publication, and country of publication NOTE - For US patent applications listed herein, if a	REFERENCES CITED AND CONSIDERED BY EXAMINER IN PARENT CASE IDENTIFIED BY PLACEMENT OF "X"
	219	L- 0219	2011	Rick Merritt, PARC hosts summit on content-centric nets, EETimes, Aug. 12, 2011, http://www.eetimes.com/electronics-news/4218741/PARC-hosts-summit-on-content-centric-nets	
	220	L- 0220	2011	Afanasyev, et. al., Communications of the ACM: Privacy Preserving Network Forensics 2011	
	221	L- 0221	2008	SonicWall, Inc., 2008 "The Advantages of a Multi-core Architecture In Network Security Appliances" http://www.sonicwall.com/downloads/WP-ENG-010_Multicore...	
	222	L- 0222	2013	Voip-Pal.Com Inc's Lawful Intercept Patent Application Receives the Allowance for Issuance as a Patent, http://finance.yahoo.com/news/voip-pal-com-inc-lawful-133000133.html	
	223	L- 0223	2013	Deep Content Inspection - Wikipedia, the free encyclopedia, http://en.wikipedia.org/wiki/Deep_content_inspection (last visited Apr. 4, 2013)	
	224	L- 0224	2009	Dexter, et. al, "Multi-view Synchronization of Human Actions and Dynamic Scenes" pp 1-11, 2009	
	225	L- 0225	2011	Kudrle, et al., "Fingerprinting for Solving A/V Synchronization Issues within Broadcast Environments", 2011	
	226	L- 0226	2010	Junego, et. al., "View-Independent Action Recognition from Temporal Self-Similarities", 2011	
	227	L- 0227	2009	Dexter, et al., "Multi-view Synchronization Of Image Sequences", 2009	
	228	L- 0228	2013	Blue Spike, LLC. v. Texas Instruments, Inc et. al, (No: 6:12-CV-499-MHS), Audible Magic Corporations's amended Answer (E.D. TX filed 7/15/2013) (Document 885 page ID 9581), (PACER)	
	229	L- 0229	2006	Moskowitz, "Introduction-Digital Rights Management," Multimedia Security Technologies for Digital Rights Management (2006), Elsevier	

DATE:	EXAMINER'S SIGNATURE:
-------	-----------------------

Printed: March 20, 2015 (12:02pm)

Path: Y:\Clients\SCOT Scott A Moskowitz and Wistaria Trading,

Inc\SCOT0014-4\Drafts\ReferenceCitationList_SCOT0014-4_3-12-2015.wpd

37 CFR 1.98(a)(1)(i) APPLICATION & ATTORNEY DOCKET: 11/895,388 / SCOT0014-4

37 CFR 1.98(a)(1)(iii): THIS IS AN INFORMATION DISCLOSURE STATEMENT

EXAMINER INITIAL	REF. NO. (L series)	REFERENCE NUMBER (L Series)	PUB. DATE	INCLUDE IN SEQUENCE: Name of first author (in CAPITAL LETTERS), Title in quotation marks, name of publication, date or publication, page numbers, publisher, city of publication, and country of publication NOTE - For US patent applications listed herein, if a	REFERENCES CITED AND CONSIDERED BY EXAMINER IN PARENT CASE IDENTIFIED BY PLACEMENT OF "X"
	230	L- 0230	1999	George, Mercy; Chouinard, Jean-Yves; Georgana, Nicolas. Digital Watermarking of Images and video using Direct Sequence Spread Spectrum Techniques. 1999 IEEE Canadian Conference on Electrical and Computer Engineering Vol. 1. Pub. Date: 1999 Relevant pages 116-121. http://ieeexplore.ieee.org/stamp/stamp.jsp?tp=arnumber=807181	
	231	L- 0231	4/4/2014	Shazam Entertainment Limited's Amended Answer to Blue Spike, LLC's complaint and counterclaims against Blue Spike LLC, Blue Spike, Inc and Scott A. Moskowitz , Shazam Entertainment Ltd v. Blue Spike, LLC, Blue Spike, Inc, and Scott Moskowitz (E.D.T.X Dist Ct.) Case No. 6:12-CV-00499-MHS	
	232	L- 0232	4/4/2014	Audible Magic Corporation's Second Amended Answer to Blue Spike LLC's Original Complaint for patent infringement and counterclaims against Blue Spike LLC, Blue Spike, Inc and Scott Moskowitz. Blue Spike LLC v. Texas Instruments, Audible Magic Corporation (E.D.T.X Dist Ct.) Case No. 6:12-CV-499-MHS	
	233	L- 0233	12/19/2011	Shrivastava, et.al. , "Data-Driven Visual Similarity for Cross-Domain Image Matching", 2011 ACM Transaction of Graphics (TOG), ACM SIGGRAPH Asia vol. 30 number 6, http://graphics.cs.cmu.edu/projects/crossDomainMatching/	
	234	L- 0234	12/6/2011	Spice, Byron, "Carnegie Mellon Researchers Develop Computerized Method for Finding Similar Images in Photos, Paintings, Sketches", Carnegie Mellon News, Dec 6, 2011, Carnegie Mellon University. http://www.cmu.edu/news/stories/archives/2011/december/dec6_matchingimages.html	
	235	L- 0235	10/16/2014	Memorandum Opinion and Order, Blue Spike LLC v. Texas Instruments, Inc. et al., (E.D.T.X Dist Ct), Case No. 6:12-CV-0499-MHS-CMC (Doc#1831 PageID#27507)	

DATE:	EXAMINER'S SIGNATURE:
-------	-----------------------

Printed: March 20, 2015 (12:02pm)

Path: Y:\Clients\SCOT Scott A Moskowitz and Wistaria Trading,

Inc\SCOT0014-4\Drafts\ReferenceCitationList_SCOT0014-4_3-12-2015.wpd

37 CFR 1.98(a)(1)(i) APPLICATION & ATTORNEY DOCKET: 11/895,388 / SCOT0014-4

37 CFR 1.98(a)(1)(iii): THIS IS AN INFORMATION DISCLOSURE STATEMENT

EXAMINER INITIAL	REF. NO. (L series)	REFERENCE NUMBER (L Series)	PUB. DATE	INCLUDE IN SEQUENCE: Name of first author (in CAPITAL LETTERS), Title in quotation marks, name of publication, date or publication, page numbers, publisher, city of publication, and country of publication NOTE - For US patent applications listed herein, if a	REFERENCES CITED AND CONSIDERED BY EXAMINER IN PARENT CASE IDENTIFIED BY PLACEMENT OF "X"
	236	L- 0236	10/16/2014	Memorandum Opinion and Order, Blue Spike LLC v. Texas Instruments, Inc. et al., (E.D.T.X Dist Ct), Case No. 6:12-CV-0499-MHS-CMC (Doc#1834 PageID#27597)	
	237	L- 0237	1989	Yu, Che-Fn, "Access Control and Authorization Plan for Customer Control of Network Services", IEEE GLOBECOM 1989 Pub 1989. pgs 862-869. http://ieeexplore.ieee.org/stamp/stamp.jsp?tp=&arnumber=64085	
	238	L- 0238	1996	Jaeger, Trent; Prakash, Atul; Rubin, Aviel D, "A System Architecture for Flexible Control of Downloaded Executable Content." Proceedings of the Fifth International Workshop on Object-Oriented in Operating Systems. Pub 1996, pgs 14-18. http://ieeexplore.ieee.org/stamp/stamp.jsp?tp=&arnumber=557855	
	239	L- 0239	5/2011	"Activate Your Product Through The Online License Management System (LMS)", May 2011 Juniper Networks, Inc., USA	
	240	L- 0240	5/2011	"Activate Your Software Capacity and/or Features", May 2011, Juniper Networks, USA	
	241	L- 0241	5/2011	"Download and Activate Your Software", May 2011, Juniper Networks, Inc., USA	
	242	L- 0242	9/2009	"Electronic Fulfillment of Feature, Capacity and Subscription License Activation Keys via the License Management System (LMS)", September 2009, Juniper Networks, Inc., USA	

DATE:	EXAMINER'S SIGNATURE:
-------	-----------------------

Printed: March 20, 2015 (12:02pm)

Path: Y:\Clients\SCOT Scott A Moskowitz and Wistaria Trading,

Inc\SCOT0014-4\Drafts\ReferenceCitationList_SCOT0014-4_3-12-2015.wpd

37 CFR 1.98(a)(1)(i) APPLICATION & ATTORNEY DOCKET: 11/895,388 / SCOT0014-4

37 CFR 1.98(a)(1)(iii): THIS IS AN INFORMATION DISCLOSURE STATEMENT

EXAMINER INITIAL	REF. NO. (L series)	REFERENCE NUMBER (L Series)	PUB. DATE	INCLUDE IN SEQUENCE: Name of first author (in CAPITAL LETTERS), Title in quotation marks, name of publication, date or publication, page numbers, publisher, city of publication, and country of publication NOTE - For US patent applications listed herein, if a	REFERENCES CITED AND CONSIDERED BY EXAMINER IN PARENT CASE IDENTIFIED BY PLACEMENT OF "X"
	243	L- 0243	7/2009	"Juniper Networks License Management System (LMS) FAQ", July 2009, Juniper Networks, Inc., USA	
	244	L- 0244	12/2014	"License Activation Keys", Dec14, 2014, http://www.juniper.net/generate_license/	
	245	L- 0245	3/2014	"License code and configuration key reference [AX 2012]", Mar 25, 2014, Microsoft http://technet.microsoft.com/en-us/library/hh378074.aspx	
	246	L- 0246	12/2014	"License Codes", Dec 14, 2014, Oracle http://www.oracle.com/us/support/licensecodes/index.html	
	247	L- 0247	12/2014	"PeopleSoft Enterprise: License Codes", Dec 14, 2014, http://www.oracle.com/us/support/licensecodes/peoplesoft-enterprise/index.html	
	248	L- 0248	12/2014	"Primavera License Key Files", Dec 14, 2014, http://www.oracle.com/us/support/licensecodes/primavera/index.html	
	249	L- 0249	12/2014	"Siebel License Keys", Dec 14, 2014, http://www.oracle.com/us/support/licensecodes/siebel/index.html	
	250	L- 0250	03/2009	"How to transfer a license activation key to an RMA replacement device", March 2009, Juniper Networks, Inc. USA	

DATE:	EXAMINER'S SIGNATURE:
-------	-----------------------

Printed: March 20, 2015 (12:02pm)

Path: Y:\Clients\SCOT Scott A Moskowitz and Wistaria Trading,

Inc\SCOT0014-4\Drafts\ReferenceCitationList_SCOT0014-4_3-12-2015.wpd

37 CFR 1.98(a)(1)(i) APPLICATION & ATTORNEY DOCKET: 11/895,388 / SCOT0014-4

37 CFR 1.98(a)(1)(iii): THIS IS AN INFORMATION DISCLOSURE STATEMENT

EXAMINER INITIAL	REF. NO. (L series)	REFERENCE NUMBER (L Series)	PUB. DATE	INCLUDE IN SEQUENCE: Name of first author (in CAPITAL LETTERS), Title in quotation marks, name of publication, date of publication, page numbers, publisher, city of publication, and country of publication NOTE - For US patent applications listed herein, if a	REFERENCES CITED AND CONSIDERED BY EXAMINER IN PARENT CASE IDENTIFIED BY PLACEMENT OF "X"
	251	L- 0251	12/2014	"How to register a license key in My VMware (2011177)", Dec 14, 2014, http://kb.vmware.com/selfservice/microsites/search.do?cmd=displayKC&docType=ex&bbid=TSEBB_1334428459608&url=&stateId=1%200%20462914399&dialogID=462898852&docTypeID=DT_KB_1_1&externalId=2011177&sliceId=1&rflid=	
	252	L- 0252	7/2001	CHAUSSEE, "Inside Windows Product Activation", July 2001, http://www.licenturion.com/xp	
	253	L- 0253	12/2014	"How to generate and validate a software key license", Dec 14, 2014, Stack Overflow, http://stackoverflow.com/questions/599837/how-to-generate-and-validate-a-software-license-key	
	254	L- 0254	7/2005	DONSW, "License Key Generation", Jul 2005, Code Project, http://www.codeproject.com/articles/11012/License-Key-Generation	
	255	L- 0255	12/2004	"How are Software License Keys generated?", Dec 14, 2014, Stack Overflow, http://stackoverflow.com/questions/3002067/how-are-software-license-keys-generated	
	256	L- 0256	3/2015	Decision on Appeal, USPTO PTAB Appeal No. 2012-011854 for application 11/895,388 issued March 12, 2015.	

DATE:	EXAMINER'S SIGNATURE:
-------	-----------------------

Electronic Patent Application Fee Transmittal

Application Number:	11895388			
Filing Date:	24-Aug-2007			
Title of Invention:	Data protection method and device			
First Named Inventor/Applicant Name:	Scott A. Moskowitz			
Filer:	Richard A. Neifeld/Jamaal Evans			
Attorney Docket Number:	SCOT0014-4			
Filed as Large Entity				
Filing Fees for Utility under 35 USC 111(a)				
Description	Fee Code	Quantity	Amount	Sub-Total in USD(\$)
Basic Filing:				
Pages:				
Claims:				
Miscellaneous-Filing:				
Petition:				
Patent-Appeals-and-Interference:				
Post-Allowance-and-Post-Issuance:				
Extension-of-Time:				

Description	Fee Code	Quantity	Amount	Sub-Total in USD(\$)
Miscellaneous:				
Submission- Information Disclosure Stmt	1806	1	180	180
Total in USD (\$)				180

Electronic Acknowledgement Receipt

EFS ID:	21831399
Application Number:	11895388
International Application Number:	
Confirmation Number:	2103
Title of Invention:	Data protection method and device
First Named Inventor/Applicant Name:	Scott A. Moskowitz
Customer Number:	31518
Filer:	Richard A. Neifeld/Jamaal Evans
Filer Authorized By:	Richard A. Neifeld
Attorney Docket Number:	SCOT0014-4
Receipt Date:	20-MAR-2015
Filing Date:	24-AUG-2007
Time Stamp:	12:23:37
Application Type:	Utility under 35 USC 111(a)

Payment information:

Submitted with Payment	yes
Payment Type	Credit Card
Payment was successfully received in RAM	\$ 180
RAM confirmation Number	9542
Deposit Account	
Authorized User	

The Director of the USPTO is hereby authorized to charge indicated fees and credit any overpayment as follows:

--	--	--	--	--	--

File Listing:

Document Number	Document Description	File Name	File Size(Bytes)/ Message Digest	Multi Part /.zip	Pages (if appl.)
1		IDS_SCOT0014-4_3-12-2015.pdf	47948 6ff0ae96162bb25ec4920aea46e80ec321820ed6	yes	11

Multipart Description/PDF files in .zip description					
Document Description		Start	End		
Transmittal Letter		1	1		
Information Disclosure Statement (IDS) Form (SB08)		2	11		

Warnings:

Information:

2	Information Disclosure Statement (IDS) Form (SB08)	ReferenceCitationList_SCOT0014-4_3-12-2015.pdf	221415 65bb91e512a0315440089bec70d5cf00a7ea95d	no	49
---	--	--	---	----	----

Warnings:

Information:

This is not an USPTO supplied IDS fillable form

3	Non Patent Literature	L213_UareUReviewersGuide_1998.pdf	182348 c5068bf0bac7590384a57ebba310498b1d79a5e2	no	4
---	-----------------------	-----------------------------------	--	----	---

Warnings:

Information:

4	Non Patent Literature	L214_MarketingFlyer1_1998-1999.pdf	2636798 6da3c324298bb657c393568b6efde125c016377a	no	1
---	-----------------------	------------------------------------	---	----	---

Warnings:

Information:

5	Non Patent Literature	L215_UAreU_UserGuideVer1_1998.pdf	3790512 7b6e371f3d6670e314f8829a36899bedda38300	no	4
---	-----------------------	-----------------------------------	--	----	---

Warnings:

The page size in the PDF is too large. The pages should be 8.5 x 11 or A4. If this PDF is submitted, the pages will be resized upon entry into the Image File Wrapper and may affect subsequent processing

Information:

6	Non Patent Literature	L216_DigitalPersonaWhitePaper_1998.pdf	1159549 ec26e8fe5b2da2f77b4484b7dc7aa2c1a4869c19	no	2
Warnings:					
Information:					
7	Non Patent Literature	L217_DigitalPersonaReleasesUareU_2000.pdf	1456215 8d85a71346502a6dcfb6113f5e6786427f005591	no	3
Warnings:					
Information:					
8	Non Patent Literature	L218_SonicWall.pdf	194875 90c2fb1abf0adb0418d194fe7788658a34b9745f	no	2
Warnings:					
Information:					
9	Non Patent Literature	L219_Merritt.pdf	800054 29a38f14a9b9fe482a539527c58bc72e4ef3669b	no	2
Warnings:					
Information:					
10	Non Patent Literature	L220_Afanasyev.pdf	2864802 05b8967aa87fa3b7f9f0d5dd810aa75e16e731c6	no	10
Warnings:					
Information:					
11	Non Patent Literature	L221_SonicWall.pdf	619632 1eb038e9a153c98a801c81ef2917846467071526	no	6
Warnings:					
Information:					
12	Non Patent Literature	L222_YahooFinance.pdf	160450 0c4ac4a89cf3ce92444936d1d714a5522131dda3	no	3
Warnings:					
Information:					
13	Non Patent Literature	L223_Wikipedia_DeepContentInspection.pdf	100220 d24184e7ca99bb60429a10aa053097857543a82	no	6
Warnings:					
Information:					
14	Non Patent Literature	L224_Dexter.pdf	2167746 bd93d34abf1309074c1b0e19dd08bcb8eed4318a	no	11
Warnings:					
Information:					

15	Non Patent Literature	L225_Kudrle.pdf	1775588 a503c9701e10084a5423a7d4966c01864074ef38	no	12
Warnings:					
Information:					
16	Non Patent Literature	L226_Junego.pdf	11621069 651d02ab9d911e0b538ff55c5ad6412a63c078a	no	13
Warnings:					
Information:					
17	Non Patent Literature	L227_Dexter.pdf	2167738 38257fa8681f92939b1fc340ccae83e9a0ea15c	no	11
Warnings:					
Information:					
18	Non Patent Literature	L228_AmendedAnswer_8-1-2013.pdf	13054629 fb05afe0de121eeb7f6a97653fb6c46526cde6d8	no	43
Warnings:					
Information:					
19	Non Patent Literature	L229_Moskowitz.pdf	3730187 4d977a490f62f66469ed54ed320c13fc4fbb6636	no	22
Warnings:					
Information:					
20	Non Patent Literature	L230_George_4-8-2014f.pdf	1103522 00f36ce2f8e1cc2cdd2ac244f7025a5074465ade	no	6
Warnings:					
Information:					
21	Non Patent Literature	L231_1397ShazamAmendedAnswerandCounterclaims.pdf	227094 4f430285ae3a9c3b44f23d70b2f05ada2b208393	no	34
Warnings:					
Information:					
22	Non Patent Literature	L232_1404AudibleMagicsrevisedcounterclaims2.pdf	23016516 8f64ef78137e5e9316af17eb68c3eb0ea7324ad8	no	45
Warnings:					
Information:					
23	Non Patent Literature	L233_Shrivastava.pdf	1831456 dfe713ba48d851a4abec12c8e5305a8ff2e4f319	no	3
Warnings:					
Information:					

24	Non Patent Literature	L234_Spice.pdf	3950092 0101af5507c3fc60499859af79c07c18d22429ab	no	2
Warnings:					
Information:					
25	Non Patent Literature	L235-MemoOpinionOrder.pdf	11094629 0c0913f4c3eaa741a6c5173853c36e663ab85a8d	no	69
Warnings:					
Information:					
26	Non Patent Literature	L236-MemoOpinionOrder.pdf	4906781 02b39dd93104c28d62440c76ae40587dfee279e	no	31
Warnings:					
Information:					
27	Non Patent Literature	L237_Jaeger.pdf	456055 7816ac5b9207b57cc15fbc188fe3581020045cf	no	5
Warnings:					
Information:					
28	Non Patent Literature	L238_Yu.pdf	562337 f9baaedc98def25bea5705866e21f7b0a447353f	no	8
Warnings:					
Information:					
29	Non Patent Literature	L239_JuniperNetworks.pdf	899613 b0120a420799b453b8545d74c1c93fe328d2ec3	no	1
Warnings:					
Information:					
30	Non Patent Literature	L240_JuniperNetworks.pdf	673665 60a655362a22c1311adb839cf37176ae79c6c50c	no	1
Warnings:					
Information:					
31	Non Patent Literature	L241_JuniperNetworks.pdf	991217 930cea5418563c7c903b5e77693d08a00876e5f3	no	1
Warnings:					
Information:					
32	Non Patent Literature	L242_JuniperNetworksf.pdf	4232093 e7c24d0817875a4daaecad4fb24063a1a3ecf40	no	6
Warnings:					
Information:					

33	Non Patent Literature	L243_JuniperNetworksf.pdf	2661813 dd96d428ad4653c127424b789c6e0e7ed b0fc97	no	4
Warnings:					
Information:					
34	Non Patent Literature	L244_JuniperNetworksf.pdf	716670 90ec79e4b1afb08ba0932c037f791e12afb0 5d47	no	2
Warnings:					
Information:					
35	Non Patent Literature	L245_Microsoft.pdf	1233691 e72fe09ee36a76e17b6e0d51f25c12c0023b 241e	no	3
Warnings:					
Information:					
36	Non Patent Literature	L246_Oracle.pdf	423712 37ad68efefdb44c1ba7e49d3c7810fa8c1bc b05c	no	1
Warnings:					
Information:					
37	Non Patent Literature	L247_Peoplesoft.pdf	1122398 d448a9b331ad8dc7d7c7626c8e70e3b0b5c 1eaa7	no	4
Warnings:					
Information:					
38	Non Patent Literature	L248_Primavera.pdf	457243 dea7d7b430f3ceaf608bc9bd7fa8beb7ac6f 92d	no	2
Warnings:					
Information:					
39	Non Patent Literature	L249_Siebel.pdf	301068 9a96a24b7c86b358ad2b9b54e2a0b4bf1a7 bd72a	no	1
Warnings:					
Information:					
40	Non Patent Literature	L250_Juniper.pdf	1378497 e692d0c2dafdacb7a3bc13a7faafe22d8a6a 6431	no	2
Warnings:					
Information:					
41	Non Patent Literature	L251_VMWaref.pdf	567765 ad1ff95a6b55280b90148cf03c67ffe6614d fe3	no	2
Warnings:					
Information:					

42	Non Patent Literature	L252_Chaussee.pdf	6316904 7be510e2e4655684e53ede2dc4ac10ebac26a800	no	11
Warnings:					
Information:					
43	Non Patent Literature	L253-StackOverflow.pdf	2251704 6aacf7205e4f96b6ca298d43f8231cb03c5e482	no	6
Warnings:					
Information:					
44	Non Patent Literature	L254_Donsw.pdf	3088190 f48421ce2ee67cd2363cdcfaab7fb09e762aad18	no	5
Warnings:					
Information:					
45	Non Patent Literature	L255_StackOverflow.pdf	3280298 fb69fe9d0d1f55f23b02d8cb67a2b1d9f5be6a77	no	7
Warnings:					
Information:					
46	Non Patent Literature	L-256_PatentBoardDecision_SCOT0014-4_3-12-2015.pdf	1627405 0c5fbb75536999f10337a509a44f337b73f678df	no	11
Warnings:					
Information:					
47	Fee Worksheet (SB06)	fee-info.pdf	30656 b1afe259f57204fec5822ba7bb832d928054bd97	no	2
Warnings:					
Information:					
Total Files Size (in bytes):				128154859	

This Acknowledgement Receipt evidences receipt on the noted date by the USPTO of the indicated documents, characterized by the applicant, and including page counts, where applicable. It serves as evidence of receipt similar to a Post Card, as described in MPEP 503.

New Applications Under 35 U.S.C. 111

If a new application is being filed and the application includes the necessary components for a filing date (see 37 CFR 1.53(b)-(d) and MPEP 506), a Filing Receipt (37 CFR 1.54) will be issued in due course and the date shown on this Acknowledgement Receipt will establish the filing date of the application.

National Stage of an International Application under 35 U.S.C. 371

If a timely submission to enter the national stage of an international application is compliant with the conditions of 35 U.S.C. 371 and other applicable requirements a Form PCT/DO/EO/903 indicating acceptance of the application as a national stage submission under 35 U.S.C. 371 will be issued in addition to the Filing Receipt, in due course.

New International Application Filed with the USPTO as a Receiving Office

If a new international application is being filed and the international application includes the necessary components for an international filing date (see PCT Article 11 and MPEP 1810), a Notification of the International Application Number and of the International Filing Date (Form PCT/RO/105) will be issued in due course, subject to prescriptions concerning national security, and the date shown on this Acknowledgement Receipt will establish the international filing date of the application.

NEIFELD REF: SCOT0014-4
CLIENT REF: SCOT0014-4
US Application and filing date: 11/895,388
USPTO CONF. NO: 2103
Inventor: MOSKOWITZ, Scott
Title: DATA PROTECTION METHOD AND DEVICE
Examiner/ArtUnit: OKEKE, Izunna/2432
ENTITY STATUS: SMALL
Priority claims and PCT Intl data:
Application 11/895,388 is a Division of 10/602,777 filed 6-25-2003 patented 7,664,263
Application 10/602,77 is a Continuation of 09/046,627 filed 3-24-1998 patented 6,598,162
Application 09/046,627 is a Continuation in Part of 08/587,943 filed 1-17-1996 patented 5,745,569

37 CFR 1.7(c) FILING RECEIPT AND TRANSMITTAL LETTER WITH AUTHORIZATION TO CHARGE DEPOSIT ACCOUNT

1. **FOR 35 USC 371 NATIONAL STAGE FILINGS, ONLY, THE COMMISSIONER IS HEREBY AUTHORIZED TO CHARGE ANY FEES WHICH MAY BE REQUIRED, OR CREDIT ANY OVERPAYMENT, TO DEPOSIT ACCOUNT NUMBER 50-2106.**

2. **FEES (PAID HEREWITH BY EFS CREDIT CARD SUBMISSION) \$: 180.00**

3. **THE FOLLOWING DOCUMENTS ARE SUBMITTED HEREWITH:**
37 CFR 1.97 INFORMATION DISCLOSURE STATEMENT
37 CFR 1.98 REFERENCE CITATION LIST CITING REFERENCES U01-U406; P01-P098; F01-F29; and L01-L256
COPIES OF REFERENCES: L213-L256

4. **FOR INTERNAL NEIFELD IP LAW, PC USE ONLY**
Disbursements: PClaw BankAcct, G/L: **6, 5010**
PCLAW BILLING REFERENCE: SCOT0001
Check#, Entry date, Amount: 2235, 3/19/2015, \$180.00
Service Fees: Amount/CreditAtty/Entry date/Services: \$600/BTM/RVM/3-19-2015/IDS filing

INITIALS OF PERSON WHO **ENTERED** ACCOUNTING DATA: BTM
ATTORNEY SIGNATURE (AUTHORIZING DEPOSIT ACCOUNT)

DATE: 3/19/2015 SIGNATURE: /BruceMargulies/
PRINTED NAME: Bruce T. Margulies

Printed: March 20, 2015 (12:01pm)
Y:\Clients\SCOT Scott A Moskowitz and Wistaria Trading, Inc\SCOT0014-4\Drafts\IDS_SCOT0014-4_3-12-2015.wpd

Neifeld Docket No: SCOT0014-4

Application/Patent No: 11/895,388

USPTO CONFIRMATION NO: 2103

File/Issue Date: 8/24/2007

Inventor/title: Moskowitz/ Data protection method and device

Examiner/ArtUnit: Izunna OKEKE/2432

ENTITY STATUS: SMALL (CONVERT UPON ALLOWANCE TO LARGE)

Priority: Application No. 09/046,627 (which issued July 22, 2003, as U.S. Patent No. 6,598,162)

**37 CFR 1.7(c) FILING RECEIPT AND TRANSMITTAL LETTER WITH
AUTHORIZATION TO CHARGE DEPOSIT ACCOUNT**

1. **THE COMMISSIONER IS HEREBY AUTHORIZED TO CHARGE ANY FEES WHICH MAY BE REQUIRED, OR CREDIT ANY OVERPAYMENT, TO DEPOSIT ACCOUNT NUMBER 50-2106.**

2. **FEES (PAID HEREWITH BY EFS CREDIT CARD SUBMISSION) \$ 0**

A. **CLAIMS FEES**

B. **OTHER FEES**

3. **THE FOLLOWING DOCUMENTS ARE SUBMITTED HEREWITH:**

Request for Status

4. **FOR INTERNAL NEIFELD IP LAW, PC USE ONLY**

acct/ck/No/date/amnt: 6/

Firm charge:

INITIALS OF PERSON WHO **ENTERED** ACCOUNTING DATA: RAN

ATTORNEY SIGNATURE (AUTHORIZING DEPOSIT ACCOUNT)

5/29/2015

/RichardNeifeld#35,299/

RICHARD NEIFELD, REG. NO. 35,299

ATTORNEY OF RECORD

Printed: May 29, 2015 (5:02pm)

Y:\Clients\SCOT Scott A Moskowitz and Wistaria Trading,

Inc\SCOT0014-4\Drafts>StatusRequest_SCOT0014-4_5-29-2015.wpd

SUMMARY OF FACTS AND REQUEST FOR STATUS

Examiner Okeke called the undersigned on or about 5/27/2015 requesting status on this application. The undersigned noted that the appeal was successful in part and no time was running against the applicant. The examiner noted that his online version of the MPEP was inoperative and he would have to get back to the undersigned. As of 5/29/2015, 4 PM, the undersigned has not heard back. The undersigned requests status on action on this application.

The remainder of these remarks are guidance for the examiner taken from the MPEP, and facts from this application.

The Notice of Appeal was filed 3/12/2012. MPEP 1214.03, states that ¶ 12.292 should be used if the Notice of Appeal was filed after 1/23/2012. ¶ 12.292 reads as follows:

¶ 12.292 Examiner Sustained in Part - Requirement of Rewriting Dependent Claims (At Least One Allowed Claim)

The Patent Trial and Appeal Board affirmed the rejection(s) against independent claim(s) [1], but reversed all rejections against claim(s) [2] dependent thereon. The independent claim(s) is/are cancelled by the examiner in accordance with MPEP § 1214.06. Applicant is given a ONE MONTH TIME PERIOD from the mailing date of this letter in which to present the dependent claim(s) in independent form. NO EXTENSIONS OF TIME UNDER 37 CFR 1.136 WILL BE GRANTED. Failure to comply will result in cancellation of the dependent claims and the application will be allowed with claim(s) [3]. Prosecution is otherwise closed.

Examiner Note:

- 1 For use if the notice of appeal was filed on or after January 23, 2012.
2. In bracket 1, enter the independent claim number(s) for which the Board affirmed the rejection(s).
3. In bracket 2, enter the dependent claim number(s) for which the Board reversed the rejection(s).
4. In bracket 3, enter the claim number(s) of the allowed claims.

This section applies because (1) there were claims allowed prior to and during the appeal (in that the examiner withdrew rejections of certain claims) and dependent claims are allowed (rejection reversed) for which their independent claims are not allowed (rejection affirmed).

Pursuant to MPEP 1214.03 and form ¶ 12.292 you should either issue an action consistent with the information above, setting a ONE MONTH TIME PERIOD from the mailing date for the applicant to amend the claims as noted above. Alternatively in order to expedite issuance I authorize you to take that action yourself. Specifically, I authorized you to amend the allowed dependent claims (those for which you withdrew the rejection and those for which the Board reversed the rejection) to place those claims in independent form, and to cancel the claims for which the Board sustained a rejection. I summarize below the status of allowed and rejected claims.

The decision on appeal, page 2, states that:

Appellant appeals under 35 U.S.C. § 134(a) from a rejection of claims 32, 33, 35--44, 52, 53, 55-57, and 59-64. Claims 1-31 and 46-51 are canceled. Claims 34, 45, 54, and 58 are objected to, but are otherwise indicated as being allowable if rewritten in independent form with all parent claim recitations. Ans. 2. We have jurisdiction over the pending claims under 35 U.S.C. § 6(b).
We AFFIRM-IN-PART.

The decision on appeal, page 11, states that:

The rejection of claims 32, 33, 35, 37, 39, 52, 53, 55-57, 59, and 63-64 under 35 U.S.C. § 103(a) is affirmed.

The rejection of claims 36, 38, 40--44, and 60-62 under 35 U.S.C. § 103(a) is reversed.

The Final Office action dated 9-20-2011, Office Action Summary page, specified that claims 32-45 and 52-64 were pending and rejected. However, the examiner's answer dated 8/8/2012, page 2, withdrew the rejections of claims 34, 45, 54, and 58.

Therefore, the rejections of claims 34, 45, 54, and 58 have been withdrawn and the rejections of claims 36, 38, 40--44, and 60-62 were reversed.

The appeal brief, claims appendix, at appeal brief page 114, shows the following claim status and dependency;

1-31 Canceled.

32 I, rejected
33-37, 38 depend from 31 (34, 36, 38 allowed)
37 depends from 35, rejected

40 I, allowed
41-42, 45 depend from 40 (41-42, 45 all allowed)
43 depends from 41, allowed
44 depends from 43, allowed
46-51 Canceled

52. I, rejected
53-54, 56-57 depend from 52 (54 allowed)
55 depends from 53, rejected

58 I, allowed
59 I, rejected
60 depends from 59, allowed
61 I, allowed

- 62 I, allowed
- 63 I, rejected
- 64 I, rejected

Allowed dependent claims 34, 36, 38 depend from rejected base claim 32 and need to be rewritten in independent form.
Allowed dependent claims 41-42, 45, and 43 and 44, depend from allowed claim 40 and do not need to be rewritten in independent form.
Allowed dependent claim 54 depends from rejected independent claim 52 and needs to be rewritten in independent form.
Allowed dependent claim 60 depends from rejected independent claim 59 and needs to be rewritten in independent form.
The rejected claims should be canceled.

Truly, /Richard Neifeld/
RICHARD NEIFELD, REG. NO. 35,299
ATTORNEY OF RECORD

ran
Date/TimeCode: May 29, 2015 (5:02pm)
Y:\Clients\SCOT Scott A Moskowitz and Wistaria Trading,
Inc\SCOT0014-4\Drafts>StatusRequest_SCOT0014-4_5-29-2015.wpd

Electronic Acknowledgement Receipt

EFS ID:	22488019
Application Number:	11895388
International Application Number:	
Confirmation Number:	2103
Title of Invention:	Data protection method and device
First Named Inventor/Applicant Name:	Scott A. Moskowitz
Customer Number:	31518
Filer:	Richard A. Neifeld
Filer Authorized By:	
Attorney Docket Number:	SCOT0014-4
Receipt Date:	29-MAY-2015
Filing Date:	24-AUG-2007
Time Stamp:	17:09:07
Application Type:	Utility under 35 USC 111(a)

Payment information:

Submitted with Payment	no
------------------------	----

File Listing:

Document Number	Document Description	File Name	File Size(Bytes)/ Message Digest	Multi Part /.zip	Pages (if appl.)
1	Request for status of Application	StatusRequest_SCOT0014-4_5-29-2015.pdf	91614 <small>a0f9d52c70d12147a4a754fa07e523d71053ed7f</small>	no	4

Warnings:

Information:

This Acknowledgement Receipt evidences receipt on the noted date by the USPTO of the indicated documents, characterized by the applicant, and including page counts, where applicable. It serves as evidence of receipt similar to a Post Card, as described in MPEP 503.

New Applications Under 35 U.S.C. 111

If a new application is being filed and the application includes the necessary components for a filing date (see 37 CFR 1.53(b)-(d) and MPEP 506), a Filing Receipt (37 CFR 1.54) will be issued in due course and the date shown on this Acknowledgement Receipt will establish the filing date of the application.

National Stage of an International Application under 35 U.S.C. 371

If a timely submission to enter the national stage of an international application is compliant with the conditions of 35 U.S.C. 371 and other applicable requirements a Form PCT/DO/EO/903 indicating acceptance of the application as a national stage submission under 35 U.S.C. 371 will be issued in addition to the Filing Receipt, in due course.

New International Application Filed with the USPTO as a Receiving Office

If a new international application is being filed and the international application includes the necessary components for an international filing date (see PCT Article 11 and MPEP 1810), a Notification of the International Application Number and of the International Filing Date (Form PCT/RO/105) will be issued in due course, subject to prescriptions concerning national security, and the date shown on this Acknowledgement Receipt will establish the international filing date of the application.



UNITED STATES PATENT AND TRADEMARK OFFICE

UNITED STATES DEPARTMENT OF COMMERCE
United States Patent and Trademark Office
Address: COMMISSIONER FOR PATENTS
P.O. Box 1450
Alexandria, Virginia 22313-1450
www.uspto.gov

NOTICE OF ALLOWANCE AND FEE(S) DUE

31518 7590 06/04/2015
NEIFELD IP LAW, PC
4813-B EISENHOWER AVENUE
ALEXANDRIA, VA 22304

EXAMINER

OKEKE, IZUNNA

ART UNIT PAPER NUMBER

2432

DATE MAILED: 06/04/2015

Table with 5 columns: APPLICATION NO., FILING DATE, FIRST NAMED INVENTOR, ATTORNEY DOCKET NO., CONFIRMATION NO.

11/895,388 08/24/2007 Scott A. Moskowitz SCOT0014-4 2103

TITLE OF INVENTION: Data protection method and device

Table with 7 columns: APPLN. TYPE, ENTITY STATUS, ISSUE FEE DUE, PUBLICATION FEE DUE, PREV. PAID ISSUE FEE, TOTAL FEE(S) DUE, DATE DUE

nonprovisional SMALL \$480 \$0 \$0 \$480 09/04/2015

THE APPLICATION IDENTIFIED ABOVE HAS BEEN EXAMINED AND IS ALLOWED FOR ISSUANCE AS A PATENT. PROSECUTION ON THE MERITS IS CLOSED. THIS NOTICE OF ALLOWANCE IS NOT A GRANT OF PATENT RIGHTS. THIS APPLICATION IS SUBJECT TO WITHDRAWAL FROM ISSUE AT THE INITIATIVE OF THE OFFICE OR UPON PETITION BY THE APPLICANT. SEE 37 CFR 1.313 AND MPEP 1308.

THE ISSUE FEE AND PUBLICATION FEE (IF REQUIRED) MUST BE PAID WITHIN THREE MONTHS FROM THE MAILING DATE OF THIS NOTICE OR THIS APPLICATION SHALL BE REGARDED AS ABANDONED. THIS STATUTORY PERIOD CANNOT BE EXTENDED. SEE 35 U.S.C. 151. THE ISSUE FEE DUE INDICATED ABOVE DOES NOT REFLECT A CREDIT FOR ANY PREVIOUSLY PAID ISSUE FEE IN THIS APPLICATION. IF AN ISSUE FEE HAS PREVIOUSLY BEEN PAID IN THIS APPLICATION (AS SHOWN ABOVE), THE RETURN OF PART B OF THIS FORM WILL BE CONSIDERED A REQUEST TO REAPPLY THE PREVIOUSLY PAID ISSUE FEE TOWARD THE ISSUE FEE NOW DUE.

HOW TO REPLY TO THIS NOTICE:

I. Review the ENTITY STATUS shown above. If the ENTITY STATUS is shown as SMALL or MICRO, verify whether entitlement to that entity status still applies.

If the ENTITY STATUS is the same as shown above, pay the TOTAL FEE(S) DUE shown above.

If the ENTITY STATUS is changed from that shown above, on PART B - FEE(S) TRANSMITTAL, complete section number 5 titled "Change in Entity Status (from status indicated above)".

For purposes of this notice, small entity fees are 1/2 the amount of undiscounted fees, and micro entity fees are 1/2 the amount of small entity fees.

II. PART B - FEE(S) TRANSMITTAL, or its equivalent, must be completed and returned to the United States Patent and Trademark Office (USPTO) with your ISSUE FEE and PUBLICATION FEE (if required). If you are charging the fee(s) to your deposit account, section "4b" of Part B - Fee(s) Transmittal should be completed and an extra copy of the form should be submitted. If an equivalent of Part B is filed, a request to reapply a previously paid issue fee must be clearly made, and delays in processing may occur due to the difficulty in recognizing the paper as an equivalent of Part B.

III. All communications regarding this application must give the application number. Please direct all communications prior to issuance to Mail Stop ISSUE FEE unless advised to the contrary.

IMPORTANT REMINDER: Utility patents issuing on applications filed on or after Dec. 12, 1980 may require payment of maintenance fees. It is patentee's responsibility to ensure timely payment of maintenance fees when due.

PART B - FEE(S) TRANSMITTAL

**Complete and send this form, together with applicable fee(s), to: Mail Mail Stop ISSUE FEE
 Commissioner for Patents
 P.O. Box 1450
 Alexandria, Virginia 22313-1450
 or Fax (571)-273-2885**

INSTRUCTIONS: This form should be used for transmitting the ISSUE FEE and PUBLICATION FEE (if required). Blocks 1 through 5 should be completed where appropriate. All further correspondence including the Patent, advance orders and notification of maintenance fees will be mailed to the current correspondence address as indicated unless corrected below or directed otherwise in Block 1, by (a) specifying a new correspondence address; and/or (b) indicating a separate "FEE ADDRESS" for maintenance fee notifications.

CURRENT CORRESPONDENCE ADDRESS (Note: Use Block 1 for any change of address)

31518 7590 06/04/2015
 NEIFELD IP LAW, PC
 4813-B EISENHOWER AVENUE
 ALEXANDRIA, VA 22304

Note: A certificate of mailing can only be used for domestic mailings of the Fee(s) Transmittal. This certificate cannot be used for any other accompanying papers. Each additional paper, such as an assignment or formal drawing, must have its own certificate of mailing or transmission.

Certificate of Mailing or Transmission

I hereby certify that this Fee(s) Transmittal is being deposited with the United States Postal Service with sufficient postage for first class mail in an envelope addressed to the Mail Stop ISSUE FEE address above, or being facsimile transmitted to the USPTO (571) 273-2885, on the date indicated below.

_____ (Depositor's name)
_____ (Signature)
_____ (Date)

APPLICATION NO.	FILING DATE	FIRST NAMED INVENTOR	ATTORNEY DOCKET NO.	CONFIRMATION NO.
11/895,388	08/24/2007	Scott A. Moskowitz	SCOT0014-4	2103

TITLE OF INVENTION: Data protection method and device

APPLN. TYPE	ENTITY STATUS	ISSUE FEE DUE	PUBLICATION FEE DUE	PREV. PAID ISSUE FEE	TOTAL FEE(S) DUE	DATE DUE
nonprovisional	SMALL	\$480	\$0	\$0	\$480	09/04/2015

EXAMINER	ART UNIT	CLASS-SUBCLASS
OKEKE, IZUNNA	2432	713-176000

<p>1. Change of correspondence address or indication of "Fee Address" (37 CFR 1.363).</p> <p><input type="checkbox"/> Change of correspondence address (or Change of Correspondence Address Form PTO/SB/122) attached.</p> <p><input type="checkbox"/> "Fee Address" indication (or "Fee Address" Indication form PTO/SB/47; Rev 03-02 or more recent) attached. Use of a Customer Number is required.</p>	<p>2. For printing on the patent front page, list</p> <p>(1) The names of up to 3 registered patent attorneys or agents OR, alternatively, 1 _____</p> <p>(2) The name of a single firm (having as a member a registered attorney or agent) and the names of up to 2 registered patent attorneys or agents. If no name is listed, no name will be printed. 2 _____</p> <p>3 _____</p>
---	---

3. ASSIGNEE NAME AND RESIDENCE DATA TO BE PRINTED ON THE PATENT (print or type)

PLEASE NOTE: Unless an assignee is identified below, no assignee data will appear on the patent. If an assignee is identified below, the document has been filed for recordation as set forth in 37 CFR 3.11. Completion of this form is NOT a substitute for filing an assignment.

(A) NAME OF ASSIGNEE _____ (B) RESIDENCE: (CITY and STATE OR COUNTRY) _____

Please check the appropriate assignee category or categories (will not be printed on the patent) : Individual Corporation or other private group entity Government

<p>4a. The following fee(s) are submitted:</p> <p><input type="checkbox"/> Issue Fee</p> <p><input type="checkbox"/> Publication Fee (No small entity discount permitted)</p> <p><input type="checkbox"/> Advance Order - # of Copies _____</p>	<p>4b. Payment of Fee(s): (Please first reapply any previously paid issue fee shown above)</p> <p><input type="checkbox"/> A check is enclosed.</p> <p><input type="checkbox"/> Payment by credit card. Form PTO-2038 is attached.</p> <p><input type="checkbox"/> The director is hereby authorized to charge the required fee(s), any deficiency, or credits any overpayment, to Deposit Account Number _____ (enclose an extra copy of this form).</p>
---	---

5. **Change in Entity Status** (from status indicated above)

Applicant certifying micro entity status. See 37 CFR 1.29

Applicant asserting small entity status. See 37 CFR 1.27

Applicant changing to regular undiscounted fee status.

NOTE: Absent a valid certification of Micro Entity Status (see forms PTO/SB/15A and 15B), issue fee payment in the micro entity amount will not be accepted at the risk of application abandonment.

NOTE: If the application was previously under micro entity status, checking this box will be taken to be a notification of loss of entitlement to micro entity status.

NOTE: Checking this box will be taken to be a notification of loss of entitlement to small or micro entity status, as applicable.

NOTE: This form must be signed in accordance with 37 CFR 1.31 and 1.33. See 37 CFR 1.4 for signature requirements and certifications.

Authorized Signature _____ Date _____

Typed or printed name _____ Registration No. _____



UNITED STATES PATENT AND TRADEMARK OFFICE

UNITED STATES DEPARTMENT OF COMMERCE
United States Patent and Trademark Office
Address: COMMISSIONER FOR PATENTS
P.O. Box 1450
Alexandria, Virginia 22313-1450
www.uspto.gov

Table with 5 columns: APPLICATION NO., FILING DATE, FIRST NAMED INVENTOR, ATTORNEY DOCKET NO., CONFIRMATION NO.

31518 7590 06/04/2015
NEIFELD IP LAW, PC
4813-B EISENHOWER AVENUE
ALEXANDRIA, VA 22304

EXAMINER

OKEKE, IZUNNA

ART UNIT PAPER NUMBER

2432

DATE MAILED: 06/04/2015

Determination of Patent Term Adjustment under 35 U.S.C. 154 (b)
(Applications filed on or after May 29, 2000)

The Office has discontinued providing a Patent Term Adjustment (PTA) calculation with the Notice of Allowance.

Section 1(h)(2) of the AIA Technical Corrections Act amended 35 U.S.C. 154(b)(3)(B)(i) to eliminate the requirement that the Office provide a patent term adjustment determination with the notice of allowance. See Revisions to Patent Term Adjustment, 78 Fed. Reg. 19416, 19417 (Apr. 1, 2013). Therefore, the Office is no longer providing an initial patent term adjustment determination with the notice of allowance. The Office will continue to provide a patent term adjustment determination with the Issue Notification Letter that is mailed to applicant approximately three weeks prior to the issue date of the patent, and will include the patent term adjustment on the patent. Any request for reconsideration of the patent term adjustment determination (or reinstatement of patent term adjustment) should follow the process outlined in 37 CFR 1.705.

Any questions regarding the Patent Term Extension or Adjustment determination should be directed to the Office of Patent Legal Administration at (571)-272-7702. Questions relating to issue and publication fee payments should be directed to the Customer Service Center of the Office of Patent Publication at 1-(888)-786-0101 or (571)-272-4200.

OMB Clearance and PRA Burden Statement for PTOL-85 Part B

The Paperwork Reduction Act (PRA) of 1995 requires Federal agencies to obtain Office of Management and Budget approval before requesting most types of information from the public. When OMB approves an agency request to collect information from the public, OMB (i) provides a valid OMB Control Number and expiration date for the agency to display on the instrument that will be used to collect the information and (ii) requires the agency to inform the public about the OMB Control Number's legal significance in accordance with 5 CFR 1320.5(b).

The information collected by PTOL-85 Part B is required by 37 CFR 1.311. The information is required to obtain or retain a benefit by the public which is to file (and by the USPTO to process) an application. Confidentiality is governed by 35 U.S.C. 122 and 37 CFR 1.14. This collection is estimated to take 12 minutes to complete, including gathering, preparing, and submitting the completed application form to the USPTO. Time will vary depending upon the individual case. Any comments on the amount of time you require to complete this form and/or suggestions for reducing this burden, should be sent to the Chief Information Officer, U.S. Patent and Trademark Office, U.S. Department of Commerce, P.O. Box 1450, Alexandria, Virginia 22313-1450. DO NOT SEND FEES OR COMPLETED FORMS TO THIS ADDRESS. SEND TO: Commissioner for Patents, P.O. Box 1450, Alexandria, Virginia 22313-1450. Under the Paperwork Reduction Act of 1995, no persons are required to respond to a collection of information unless it displays a valid OMB control number.

Privacy Act Statement

The Privacy Act of 1974 (P.L. 93-579) requires that you be given certain information in connection with your submission of the attached form related to a patent application or patent. Accordingly, pursuant to the requirements of the Act, please be advised that: (1) the general authority for the collection of this information is 35 U.S.C. 2(b)(2); (2) furnishing of the information solicited is voluntary; and (3) the principal purpose for which the information is used by the U.S. Patent and Trademark Office is to process and/or examine your submission related to a patent application or patent. If you do not furnish the requested information, the U.S. Patent and Trademark Office may not be able to process and/or examine your submission, which may result in termination of proceedings or abandonment of the application or expiration of the patent.

The information provided by you in this form will be subject to the following routine uses:

1. The information on this form will be treated confidentially to the extent allowed under the Freedom of Information Act (5 U.S.C. 552) and the Privacy Act (5 U.S.C. 552a). Records from this system of records may be disclosed to the Department of Justice to determine whether disclosure of these records is required by the Freedom of Information Act.
2. A record from this system of records may be disclosed, as a routine use, in the course of presenting evidence to a court, magistrate, or administrative tribunal, including disclosures to opposing counsel in the course of settlement negotiations.
3. A record in this system of records may be disclosed, as a routine use, to a Member of Congress submitting a request involving an individual, to whom the record pertains, when the individual has requested assistance from the Member with respect to the subject matter of the record.
4. A record in this system of records may be disclosed, as a routine use, to a contractor of the Agency having need for the information in order to perform a contract. Recipients of information shall be required to comply with the requirements of the Privacy Act of 1974, as amended, pursuant to 5 U.S.C. 552a(m).
5. A record related to an International Application filed under the Patent Cooperation Treaty in this system of records may be disclosed, as a routine use, to the International Bureau of the World Intellectual Property Organization, pursuant to the Patent Cooperation Treaty.
6. A record in this system of records may be disclosed, as a routine use, to another federal agency for purposes of National Security review (35 U.S.C. 181) and for review pursuant to the Atomic Energy Act (42 U.S.C. 218(c)).
7. A record from this system of records may be disclosed, as a routine use, to the Administrator, General Services, or his/her designee, during an inspection of records conducted by GSA as part of that agency's responsibility to recommend improvements in records management practices and programs, under authority of 44 U.S.C. 2904 and 2906. Such disclosure shall be made in accordance with the GSA regulations governing inspection of records for this purpose, and any other relevant (i.e., GSA or Commerce) directive. Such disclosure shall not be used to make determinations about individuals.
8. A record from this system of records may be disclosed, as a routine use, to the public after either publication of the application pursuant to 35 U.S.C. 122(b) or issuance of a patent pursuant to 35 U.S.C. 151. Further, a record may be disclosed, subject to the limitations of 37 CFR 1.14, as a routine use, to the public if the record was filed in an application which became abandoned or in which the proceedings were terminated and which application is referenced by either a published application, an application open to public inspection or an issued patent.
9. A record from this system of records may be disclosed, as a routine use, to a Federal, State, or local law enforcement agency, if the USPTO becomes aware of a violation or potential violation of law or regulation.

Notice of Allowability	Application No. 11/895,388	Applicant(s) MOSKOWITZ, SCOTT A.	
	Examiner IZUNNA OKEKE	Art Unit 2432	AIA (First Inventor to File) Status No

-- The MAILING DATE of this communication appears on the cover sheet with the correspondence address--

All claims being allowable, PROSECUTION ON THE MERITS IS (OR REMAINS) CLOSED in this application. If not included herewith (or previously mailed), a Notice of Allowance (PTOL-85) or other appropriate communication will be mailed in due course. **THIS NOTICE OF ALLOWABILITY IS NOT A GRANT OF PATENT RIGHTS.** This application is subject to withdrawal from issue at the initiative of the Office or upon petition by the applicant. See 37 CFR 1.313 and MPEP 1308.

1. This communication is responsive to 03/12/2015.
 A declaration(s)/affidavit(s) under **37 CFR 1.130(b)** was/were filed on _____.
2. An election was made by the applicant in response to a restriction requirement set forth during the interview on _____; the restriction requirement and election have been incorporated into this action.
3. The allowed claim(s) is/are 34,36,38,40-45,54,58 and 60-62. As a result of the allowed claim(s), you may be eligible to benefit from the **Patent Prosecution Highway** program at a participating intellectual property office for the corresponding application. For more information, please see http://www.uspto.gov/patents/init_events/pph/index.jsp or send an inquiry to PPHfeedback@uspto.gov.
4. Acknowledgment is made of a claim for foreign priority under 35 U.S.C. § 119(a)-(d) or (f).

Certified copies:

- a) All b) Some *c) None of the:
 1. Certified copies of the priority documents have been received.
 2. Certified copies of the priority documents have been received in Application No. _____.
 3. Copies of the certified copies of the priority documents have been received in this national stage application from the International Bureau (PCT Rule 17.2(a)).

* Certified copies not received: _____.

Applicant has THREE MONTHS FROM THE "MAILING DATE" of this communication to file a reply complying with the requirements noted below. Failure to timely comply will result in ABANDONMENT of this application.

THIS THREE-MONTH PERIOD IS NOT EXTENDABLE.

5. CORRECTED DRAWINGS (as "replacement sheets") must be submitted.
 including changes required by the attached Examiner's Amendment / Comment or in the Office action of Paper No./Mail Date _____.
Identifying indicia such as the application number (see 37 CFR 1.84(c)) should be written on the drawings in the front (not the back) of each sheet. Replacement sheet(s) should be labeled as such in the header according to 37 CFR 1.121(d).
6. DEPOSIT OF and/or INFORMATION about the deposit of BIOLOGICAL MATERIAL must be submitted. Note the attached Examiner's comment regarding REQUIREMENT FOR THE DEPOSIT OF BIOLOGICAL MATERIAL.

Attachment(s)

- | | |
|---|---|
| <ol style="list-style-type: none"> 1. <input type="checkbox"/> Notice of References Cited (PTO-892) 2. <input checked="" type="checkbox"/> Information Disclosure Statements (PTO/SB/08),
Paper No./Mail Date <u>03/20/2015</u> 3. <input type="checkbox"/> Examiner's Comment Regarding Requirement for Deposit of Biological Material 4. <input type="checkbox"/> Interview Summary (PTO-413),
Paper No./Mail Date _____. | <ol style="list-style-type: none"> 5. <input checked="" type="checkbox"/> Examiner's Amendment/Comment 6. <input checked="" type="checkbox"/> Examiner's Statement of Reasons for Allowance 7. <input type="checkbox"/> Other _____. |
|---|---|

/IZUNNA OKEKE/
Primary Examiner, Art Unit 2432

DETAILED ACTION

1. The present application is being examined under the pre-AIA first to invent provisions.

EXAMINER'S AMENDMENT

2. An examiner's amendment to the record appears below. Should the changes and/or additions be unacceptable to applicant, an amendment may be filed as provided by 37 CFR 1.312. To ensure consideration of such an amendment, it **MUST** be submitted no later than the payment of the issue fee.

The application has been amended as follows: Claims 32, 33, 35, 37, 39, 46-53, 55-57, 59, 63 and 64 are canceled. Claims 34, 36, 38, 54 and 60 are amended.

Claim 32. (Canceled)

Claim 33. (Canceled)

Claim 34. (Currently Amended) A computer-based method for modifying software, comprising: receiving, in a computer having a processor and memory, software, wherein said software provides a specified functionality; embedding a watermark into said software, using said computer, said watermark encoding at least one first license code, thereby resulting in a first license code encoded watermarked software; and wherein said first license code encoded watermarked software is configured to query a user for personalization information during its installation.

Claim 35. (Canceled)

Claim 36. (Currently Amended) A computer-based method for modifying software, comprising: receiving, in a computer having a processor and memory, software, wherein said software provides a specified functionality; embedding a watermark into said software, using

said computer, said watermark encoding at least one first license code, thereby resulting in a first license code encoded watermarked software; wherein said watermark is accessible with a key; and said key enables said first license code encoded watermarked software to provide said specified functionality.

Claim 37. (Canceled)

Claim 38. (Currently Amended) A computer-based method for modifying software, comprising: receiving, in a computer having a processor and memory, software, wherein said software provides a specified functionality; embedding a watermark into said software, using said computer, said watermark encoding at least one first license code, thereby resulting in a first license code encoded watermarked software; and wherein the step of embedding the software with a watermark is performed during execution of the software.

Claim 39. (Canceled)

Claims 46-53. (Canceled)

Claim 54. (Currently Amended) A computer-based system for modifying software, comprising: a computer having a processor and memory; wherein said computer is programmed to receive software that provides a specified functionality when installed on a computer system; wherein said computer is programmed to embed a watermark into said software; wherein said watermark encodes at least one first license code, thereby resulting in a first license code encoded watermarked software; and wherein said first license code encoded watermarked software is designed to prompt for entry of licensing information and only provides a certain functionality if licensing information entered in response to said prompt comprises at least one of said at least one first license code encoded in said watermark.

Claims 55-57. (Canceled)

Claim 59. (Canceled)

Claim 60. (Currently Amended) A method for encoding software code using a computer having a processor and memory, comprising: storing a software code in said memory; wherein said software code comprises a first code resource and provides a specified underlying functionality when installed on a computer system; and encoding, by said computer using at least a first license key and an encoding algorithm, said software code, to form a first license key encoded software code; and wherein, when installed on a computer system, said first license key encoded software code will provide said specified underlying functionality only after receipt of said first license key.

Claim 63. (Canceled)

Claim 64. (Canceled)

Allowable Subject Matter

3. Claims 34, 36, 38, 40-45, 54, 58 and 60-62 are allowed.
4. The following is an examiner's statement of reasons for allowance:

The primary reason for allowance of the claims is the limitation of querying for personalization information during the installation of the watermarked software and accessing the watermark using a key which is determined from the personalization information. The watermark containing executable object code which is accessible using the key represent an improvement over the prior art that uses purely informational watermarks.

Any comments considered necessary by applicant must be submitted no later than the payment of the issue fee and, to avoid processing delays, should preferably accompany the issue

fee. Such submissions should be clearly labeled "Comments on Statement of Reasons for Allowance."

Conclusion

Any inquiry concerning this communication or earlier communications from the examiner should be directed to IZUNNA OKEKE whose telephone number is (571)270-3854. The examiner can normally be reached on Monday - Thursday.

If attempts to reach the examiner by telephone are unsuccessful, the examiner's supervisor, Gilberto Barron can be reached on (571) 272-3799. The fax phone number for the organization where this application or proceeding is assigned is 571-273-8300.

Information regarding the status of an application may be obtained from the Patent Application Information Retrieval (PAIR) system. Status information for published applications may be obtained from either Private PAIR or Public PAIR. Status information for unpublished applications is available through Private PAIR only. For more information about the PAIR system, see <http://pair-direct.uspto.gov>. Should you have questions on access to the Private PAIR system, contact the Electronic Business Center (EBC) at 866-217-9197 (toll-free). If you would like assistance from a USPTO Customer Service Representative or access to the automated information system, call 800-786-9199 (IN USA OR CANADA) or 571-272-1000.

/IZUNNA OKEKE/
Primary Examiner, Art Unit 2432

Search Notes 	Application/Control No. 11895388	Applicant(s)/Patent Under Reexamination MOSKOWITZ, SCOTT A.
	Examiner IZUNNA OKEKE	Art Unit 2432

CPC- SEARCHED		
Symbol	Date	Examiner
H04L63/0428	5/31/2015	IO
H04L2209/608	5/31/2015	IO
H04L2209/60	5/31/2015	IO

CPC COMBINATION SETS - SEARCHED		
Symbol	Date	Examiner

US CLASSIFICATION SEARCHED			
Class	Subclass	Date	Examiner

SEARCH NOTES		
Search Notes	Date	Examiner
Updated Text Search (See History)	5/31/2015	IO
Updated Keyword + Classification Search (See History)	5/31/2015	IO
Search (713/165, 713/176, 713/161, 380/201, 380/228, 380/229) (See History)	5/31/2015	IO
NPL Database Search (Google Scholar Database Search and INSPEC Database Search)	5/31/2015	IO
Inventor Name Search for Double Patenting Issues	5/31/2015	IO

INTERFERENCE SEARCH			
US Class/ CPC Symbol	US Subclass / CPC Group	Date	Examiner
	PG-PUB Text Search (See Interference Search History)	5/31/2015	IO
	UPAD Text Search (SEe Interference Search History)	5/31/2015	IO

--	--

Index of Claims 	Application/Control No. 11895388	Applicant(s)/Patent Under Reexamination MOSKOWITZ, SCOTT A.
	Examiner IZUNNA OKEKE	Art Unit 2432

✓	Rejected	-	Cancelled	N	Non-Elected	A	Appeal
=	Allowed	÷	Restricted	I	Interference	O	Objected

<input type="checkbox"/> Claims renumbered in the same order as presented by applicant		<input type="checkbox"/> CPA		<input type="checkbox"/> T.D.		<input type="checkbox"/> R.1.47	
CLAIM		DATE					
Final	Original	03/22/2010	11/11/2010	03/17/2011	09/08/2011	05/31/2015	
	32	✓	✓	✓	✓	-	
	33	✓	✓	✓	✓	-	
1	34	✓	✓	✓	✓	=	
	35	✓	✓	✓	✓	-	
2	36	✓	✓	✓	✓	=	
	37	✓	✓	✓	✓	-	
3	38	✓	✓	✓	✓	=	
	39	✓	✓	✓	✓	-	
4	40	✓	✓	✓	✓	=	
5	41	✓	✓	✓	✓	=	
6	42	✓	✓	✓	✓	=	
7	43	✓	✓	✓	✓	=	
8	44	✓	✓	✓	✓	=	
9	45	✓	✓	✓	✓	=	
	52	✓	✓	✓	✓	-	
	53	✓	✓	✓	✓	-	
10	54	✓	✓	✓	✓	=	
	55	✓	✓	✓	✓	-	
	56	✓	✓	✓	✓	-	
	57	✓	✓	✓	✓	-	
11	58	✓	✓	✓	✓	=	
	59	✓	✓	✓	✓	-	
12	60		✓	✓	✓	=	
13	61		✓	✓	✓	=	
14	62		✓	✓	✓	=	
	63		✓	✓	✓	-	
	64		✓	✓	✓	-	

Printed: March 20, 2015 (12:02pm)

Path: Y:\Clients\SCOT Scott A Moskowitz and Wistaria Trading,

Inc\SCOT0014-4\Drafts\ReferenceCitationList_SCOT0014-4_3-12-2015.wpd

37 CFR 1.98(a)(1)(i) APPLICATION & ATTORNEY DOCKET: 11/895,388 / SCOT0014-4

37 CFR 1.98(a)(1)(iii): THIS IS AN INFORMATION DISCLOSURE STATEMENT

LISTING OF UNITED STATES PATENTS - U series

EXAMINER INITIALS	REFERENCE NUMBER (U SERIES)	PATENT NUMBER	ISSUE DATE	NAME OF PATENTEE OR APPLICANT	REFERENCES CITED AND CONSIDERED BY EXAMINER IN PARENT CASE IDENTIFIED BY PLACEMENT OF "X"
	U 01	3947825	March 1976	Cassada	X
	U 02	3984624	October 1976	Waggener	X
	U 03	3986624	October 1976	Cates, Jr. et al.	X
	U 04	4038596	July 1977	Lee	X
	U 05	4200770	April 1980	Hellman et al.	X
	U 06	4218582	August 1980	Hellman et al.	X
	U 07	4339134	July 1982	Macheel	X
	U 08	4390898	June 1983	Bond et al.	X
	U 09	4405829	September 1983	Rivest et al.	X
	U 010	4424414	January 1984	Hellman et al.	X
	U 011	4528588	July 1985	Lofberg	X
	U 012	4672605	June 1987	Hustig et al.	X
	U 013	4748668	May 1988	Shamir et al.	X
	U 014	4789928	December 1988	Fujisaki	X
	U 015	4827508	May 1989	Shear	X
	U 016	4876617	October 1989	Best et al.	X
	U 017	4896275	January 1990	Jackson	X
	U 018	4908873	March 1990	Philibert et al.	X
	U 019	4939515	July 1990	Adelson	X
	U 020	4969204	November 1990	Melnychuk et al.	X
	U 021	4972471	November 1990	Gross et al.	X
	U 022	4977594	December 1990	Shear	X

DATE:	EXAMINER'S SIGNATURE:
-------	-----------------------

ALL REFERENCES CONSIDERED EXCEPT WHERE LINED THROUGH. //I.O./

Printed: March 20, 2015 (12:02pm)

Path: Y:\Clients\SCOT Scott A Moskowitz and Wistaria Trading,

Inc\SCOT0014-4\Drafts\ReferenceCitationList_SCOT0014-4_3-12-2015.wpd

37 CFR 1.98(a)(1)(i) APPLICATION & ATTORNEY DOCKET: 11/895,388 / SCOT0014-4

37 CFR 1.98(a)(1)(iii): THIS IS AN INFORMATION DISCLOSURE STATEMENT

EXAMINER INITIALS	REFERENCE NUMBER (U SERIES)	PATENT NUMBER	ISSUE DATE	NAME OF PATENTEE OR APPLICANT	REFERENCES CITED AND CONSIDERED BY EXAMINER IN PARENT CASE IDENTIFIED BY PLACEMENT OF "X"
	U 023	4979210	December 1990	Nagata et al.	X
	U 024	4980782	December 1990	Ginkel	X
	U 025	5050213	September 1991	Shear	X
	U 026	5073925	December 1991	Nagata et al.	X
	U 027	5077665	December 1991	Silverman et al.	X
	U 028	5113437	May 1992	Best et al.	X
	U 029	5136581	August 1992	Muehrcke	X
	U 030	5136646	August 1992	Haber et al.	X
	U 031	5136647	August 1992	Haber et al.	X
	U 032	5142576	August 1992	Nadan	X
	U 033	5161210	November 1992	Druyvesteyn et al.	X
	U 034	5210820	May 1993	Kenyon	X
	U 035	5243423	September 1993	DeJean et al.	X
	U 036	5243515	September 1993	Lee	X
	U 037	5287407	February 1994	Holmes	X
	U 038	5319735	June 1994	Preuss et al.	X
	U 039	5341429	August 1994	Stringer et al.	X
	U 040	5341477	August 1994	Pitkin et al.	X
	U 041	5363448	November 1994	Koopman et al.	X
	U 042	5365586	November 1994	Indeck et al.	X
	U 043	5369707	November 1994	Follendore, III	X
	U 044	5379345	January 1995	Greenberg	X
	U 045	5394324	February 1995	Clearwater	X

DATE:	EXAMINER'S SIGNATURE:
-------	-----------------------

ALL REFERENCES CONSIDERED EXCEPT WHERE LINED THROUGH. //I.O./

Printed: March 20, 2015 (12:02pm)

Path: Y:\Clients\SCOT Scott A Moskowitz and Wistaria Trading,

Inc\SCOT0014-4\Drafts\ReferenceCitationList_SCOT0014-4_3-12-2015.wpd

37 CFR 1.98(a)(1)(i) APPLICATION & ATTORNEY DOCKET: 11/895,388 / SCOT0014-4

37 CFR 1.98(a)(1)(iii): THIS IS AN INFORMATION DISCLOSURE STATEMENT

EXAMINER INITIALS	REFERENCE NUMBER (U SERIES)	PATENT NUMBER	ISSUE DATE	NAME OF PATENTEE OR APPLICANT	REFERENCES CITED AND CONSIDERED BY EXAMINER IN PARENT CASE IDENTIFIED BY PLACEMENT OF "X"
	U 046	5398285	March 1995	Borgelt et al.	X
	U 047	5406627	April 1995	Thompson et al.	X
	U 048	5408505	April 1995	Indeck et al.	X
	U 049	5410598	April 1995	Shear	X
	U 050	5412718	May 1995	Narasimhalv et al.	X
	U 051	5418713	May 1995	Allen	X
	U 052	5428606	June 1995	Moskowitz	X
	U 053	5450490	September 1995	Jensen et al.	X
	U 054	5469536	November 1995	Blank	X
	U 055	5471533	November 1995	Wang et al.	X
	U 056	5478990	December 1995	Montanari et al.	X
	U 057	5479210	December 1995	Cawley et al.	X
	U 058	5487168	January 1996	Geiner et al.	X
	U 059	5493677	February 1996	Balogh et al.	X
	U 060	5497419	March 1996	Hill	X
	U 061	5506795	April 1996	Yamakawa	X
	U 062	5513126	April 1996	Harkins et al.	X
	U 063	5513261	April 1996	Maher	X
	U 064	5530739	June 1996	Okada	X
	U 065	5530751	June 1996	Morris	X
	U 066	5530759	June 1996	Braudaway et al.	X
	U 067	5539735	July 1996	Moskowitz	X
	U 068	5548579	August 1996	Lebrun et al.	X

DATE:	EXAMINER'S SIGNATURE:
-------	-----------------------

ALL REFERENCES CONSIDERED EXCEPT WHERE LINED THROUGH. //I.O./

Printed: March 20, 2015 (12:02pm)

Path: Y:\Clients\SCOT Scott A Moskowitz and Wistaria Trading,

Inc\SCOT0014-4\Drafts\ReferenceCitationList_SCOT0014-4_3-12-2015.wpd

37 CFR 1.98(a)(1)(i) APPLICATION & ATTORNEY DOCKET: 11/895,388 / SCOT0014-4

37 CFR 1.98(a)(1)(iii): THIS IS AN INFORMATION DISCLOSURE STATEMENT

EXAMINER INITIALS	REFERENCE NUMBER (U SERIES)	PATENT NUMBER	ISSUE DATE	NAME OF PATENTEE OR APPLICANT	REFERENCES CITED AND CONSIDERED BY EXAMINER IN PARENT CASE IDENTIFIED BY PLACEMENT OF "X"
	U 069	5568570	October 1996	Rabbani	X
	U 070	5579124	November 1996	Aijala et al.	X
	U 071	5581703	December 1996	Baugher et al.	X
	U 072	5583488	December 1996	Sala et al.	X
	U 073	5598470	January 1997	Cooper et al.	X
	U 074	5606609	February 1997	Houser et al.	X
	U 075	5613004	March 1997	Cooperman et al.	X
	U 076	5617119	April 1997	Briggs et al.	X
	U 077	5625690	April 1997	Michel et al.	X
	U 078	5629980	May 1997	Stefik et al.	X
	U 079	5633932	May 1997	Davis et al.	X
	U 080	5634040	May 1997	Her et al.	X
	U 081	5636276	June 1997	Brugger	X
	U 082	5636292	June 1997	Rhoads	X
	U 083	5640569	June 1997	Miller et al.	X
	U 084	5646997	July 1997	Barton	X
	U 085	5657461	August 1997	Harkins et al.	X
	U 086	5659726	August 1997	Sandford, II et al.	X
	U 087	5664018	September 1997	Leighton	X
	U 088	5673316	September 1997	Auerbach et al.	X
	U 089	5677952	October 1997	Blakely et al.	X
	U 090	5680462	October 1997	Miller et al.	X
	U 091	5687236	November 1997	Moskowitz et al.	X

DATE:	EXAMINER'S SIGNATURE:
-------	-----------------------

ALL REFERENCES CONSIDERED EXCEPT WHERE LINED THROUGH. //I.O./

Printed: March 20, 2015 (12:02pm)

Path: Y:\Clients\SCOT Scott A Moskowitz and Wistaria Trading,

Inc\SCOT0014-4\Drafts\ReferenceCitationList_SCOT0014-4_3-12-2015.wpd

37 CFR 1.98(a)(1)(i) APPLICATION & ATTORNEY DOCKET: 11/895,388 / SCOT0014-4

37 CFR 1.98(a)(1)(iii): THIS IS AN INFORMATION DISCLOSURE STATEMENT

EXAMINER INITIALS	REFERENCE NUMBER (U SERIES)	PATENT NUMBER	ISSUE DATE	NAME OF PATENTEE OR APPLICANT	REFERENCES CITED AND CONSIDERED BY EXAMINER IN PARENT CASE IDENTIFIED BY PLACEMENT OF "X"
	U 092	5689587	November 1997	Bender et al.	X
	U 093	5696828	December 1997	Koopman, Jr.	X
	U 094	5719937	February 1998	Warren et al.	X
	U 095	5721788	February 1998	Powell et al.	X
	U 096	5734752	March 1998	Knox	X
	U 097	5737416	April 1998	Cooper et al.	X
	U 098	5737733	April 1998	Eller	X
	U 099	5740244	April 1998	Indeck et al.	X
	U 0100	5745569	April 1998	Moskowitz et al.	X
	U 0101	5748783	May 1998	Rhoads	X
	U 0102	5751811	May 1998	Magnotti et al.	X
	U 0103	5754697	May 1998	Fu et al.	X
	U 0104	5757923	May 1998	Koopman, Jr.	X
	U 0105	5765152	June 1998	Erickson	X
	U 0106	5768396	June 1998	Sone	X
	U 0107	5774452	June 1998	Wolosewicz	X
	U 0108	5790677	August 1998	Fox et al.	X
	U 0109	5799083	August 1998	Brothers et al.	X
	U 0110	5809139	September 1998	Grirod et al.	X
	U 0111	5809160	September 1998	Powell et al.	X
	U 0112	5822432	October 1998	Moskowitz et al.	X
	U 0113	5828325	October 1998	Wolosewicz et al.	X

DATE:	EXAMINER'S SIGNATURE:
-------	-----------------------

ALL REFERENCES CONSIDERED EXCEPT WHERE LINED THROUGH. //I.O./

Printed: March 20, 2015 (12:02pm)

Path: Y:\Clients\SCOT Scott A Moskowitz and Wistaria Trading,

Inc\SCOT0014-4\Drafts\ReferenceCitationList_SCOT0014-4_3-12-2015.wpd

37 CFR 1.98(a)(1)(i) APPLICATION & ATTORNEY DOCKET: 11/895,388 / SCOT0014-4

37 CFR 1.98(a)(1)(iii): THIS IS AN INFORMATION DISCLOSURE STATEMENT

EXAMINER INITIALS	REFERENCE NUMBER (U SERIES)	PATENT NUMBER	ISSUE DATE	NAME OF PATENTEE OR APPLICANT	REFERENCES CITED AND CONSIDERED BY EXAMINER IN PARENT CASE IDENTIFIED BY PLACEMENT OF "X"
	U 0114	5832119	November 1998	Rhoads	X
	U 0115	5848155	December 1998	Cox	X
	U 0116	5850481	December 1998	Rhoads	X
	U 0117	5859920	January 1999	Daly et al.	X
	U 0118	5860099	January 1999	Milios et al.	X
	U 0119	5862260	January 1999	Rhoads	X
	U 0120	5870474	February 1999	Wasilewski et al.	X
	U 0121	5884033	March 1999	Duvall et al.	X
	U 0122	5889868	March 1999	Moskowitz et al.	X
	U 0123	5893067	April 1999	Bender et al.	X
	U 0124	5894521	April 1999	Conley	X
	U 0125	5903721	May 1999	Sixtus	X
	U 0126	5905800	May 1999	Moskowitz et al.	X
	U 0127	5905975	May 1999	Ausubel	X
	U 0128	5912972	June 1999	Barton	X
	U 0129	5915027	June 1999	Cox et al.	X
	U 0130	5917915	June 1999	Hirose	X
	U 0131	5918223	June 1999	Blum	X
	U 0132	5920900	July 1999	Poole et al.	X
	U 0133	5923763	July 1999	Walker et al.	X
	U 0134	5930369	July 1999	Cox et al.	X
	U 0135	5930377	July 1999	Powell et al	. X
	U 0136	5940134	August 1999	Wirtz	X

DATE:	EXAMINER'S SIGNATURE:
-------	-----------------------

ALL REFERENCES CONSIDERED EXCEPT WHERE LINED THROUGH. //I.O./

Printed: March 20, 2015 (12:02pm)

Path: Y:\Clients\SCOT Scott A Moskowitz and Wistaria Trading,

Inc\SCOT0014-4\Drafts\ReferenceCitationList_SCOT0014-4_3-12-2015.wpd

37 CFR 1.98(a)(1)(i) APPLICATION & ATTORNEY DOCKET: 11/895,388 / SCOT0014-4

37 CFR 1.98(a)(1)(iii): THIS IS AN INFORMATION DISCLOSURE STATEMENT

EXAMINER INITIALS	REFERENCE NUMBER (U SERIES)	PATENT NUMBER	ISSUE DATE	NAME OF PATENTEE OR APPLICANT	REFERENCES CITED AND CONSIDERED BY EXAMINER IN PARENT CASE IDENTIFIED BY PLACEMENT OF "X"
	U 0137	5943422	August 1999	Van Wie et al.	X
	U 0138	5963909	October 1999	Warren et al.	X
	U 0139	5973731	October 1999	Schwab	X
	U 0140	5974141	October 1999	Saito	X
	U 0141	5991426	November 1999	Cox et al.	X
	U 0142	5999217	December 1999	Berners-Lee	X
	U 0143	6009176	December 1999	Gennaro et al.	X
	U 0144	6029126	February 2000	Malvar	X
	U 0145	6041316	March 2000	Allen	X
	U 0146	6044471	March 2000	Colvin	X
	U 0147	6049838	April 2000	Miller et al.	X
	U 0148	6051029	April 2000	Paterson et al.	X
	U 0149	6061793	May 2000	Tewfik et al.	X
	U 0150	6069914	May 2000	Cox	X
	U 0151	6078664	June 2000	Moskowitz et al.	X
	U 0152	6081251	June 2000	Sakai et al.	X
	U 0153	6081587	June 2000	Reyes et al.	X
	U 0154	6088455	July 2000	Logan et al.	X
	U 0155	6131162	October 2000	Yoshiura et al.	X
	U 0156	6141753	October 2000	Zhao et al.	X
	U 0157	6141754	October 2000	Choy	X
	U 0158	6154571	November 2000	Cox et al.	X
	U 0159	6192138	February 2001	Yamadaji	X

DATE:	EXAMINER'S SIGNATURE:
-------	-----------------------

ALL REFERENCES CONSIDERED EXCEPT WHERE LINED THROUGH. //I.O./

Printed: March 20, 2015 (12:02pm)

Path: Y:\Clients\SCOT Scott A Moskowitz and Wistaria Trading,

Inc\SCOT0014-4\Drafts\ReferenceCitationList_SCOT0014-4_3-12-2015.wpd

37 CFR 1.98(a)(1)(i) APPLICATION & ATTORNEY DOCKET: 11/895,388 / SCOT0014-4

37 CFR 1.98(a)(1)(iii): THIS IS AN INFORMATION DISCLOSURE STATEMENT

EXAMINER INITIALS	REFERENCE NUMBER (U SERIES)	PATENT NUMBER	ISSUE DATE	NAME OF PATENTEE OR APPLICANT	REFERENCES CITED AND CONSIDERED BY EXAMINER IN PARENT CASE IDENTIFIED BY PLACEMENT OF "X"
	U 0160	6199058	March 2001	Wong et al.	X
	U 0161	6205249	March 2001	Moskowitz	X
	U 0162	6208745	March 2001	Florenio et al.	X
	U 0163	6230268	May 2001	Miwa et al.	X
	U 0164	6233347	May 2001	Chen et al.	X
	U 0165	6233684	May 2001	Stefik et al.	X
	U 0166	6240121	May 2001	Senoh	X
	U 0167	6263313	July 2001	Milstead et al.	X
	U 0168	6272634	August 2001	Tewfik et al.	X
	U 0169	6275988	August 2001	Nagashima et al.	X
	U 0170	6278780	August 2001	Shimada	X
	U 0171	6278791	August 2001	Honsinger et al.	X
	U 0172	6282300	August 2001	Bloom et al.	X
	U 0173	6282650	August 2001	Davis	X
	U 0174	6285775	September 2001	Wu et al.	X
	U 0175	6301663	October 2001	Kato et al.	X
	U 0176	6310962	October 2001	Chung et al.	X
	U 0177	6330335	December 2001	Rhoads	X
	U 0178	6330672	December 2001	Shur	X
	U 0179	6345100	February 2002	Levine	X
	U 0180	6351765	February 2002	Pietropaolo et al.	X
	U 0181	6363483	March 2002	Keshav	X
	U 0182	6373892	April 2002	Ichien et al.	X

DATE:	EXAMINER'S SIGNATURE:
-------	-----------------------

ALL REFERENCES CONSIDERED EXCEPT WHERE LINED THROUGH. //I.O./

Printed: March 20, 2015 (12:02pm)

Path: Y:\Clients\SCOT Scott A Moskowitz and Wistaria Trading,

Inc\SCOT0014-4\Drafts\ReferenceCitationList_SCOT0014-4_3-12-2015.wpd

37 CFR 1.98(a)(1)(i) APPLICATION & ATTORNEY DOCKET: 11/895,388 / SCOT0014-4

37 CFR 1.98(a)(1)(iii): THIS IS AN INFORMATION DISCLOSURE STATEMENT

EXAMINER INITIALS	REFERENCE NUMBER (U SERIES)	PATENT NUMBER	ISSUE DATE	NAME OF PATENTEE OR APPLICANT	REFERENCES CITED AND CONSIDERED BY EXAMINER IN PARENT CASE IDENTIFIED BY PLACEMENT OF "X"
	U 0183	6373960	April 2002	Conover et al.	X
	U 0184	6374036	April 2002	Ryan et al.	X
	U 0185	6377625	April 2002	Kim	X
	U 0186	6381618	April 2002	Jones et al.	X
	U 0187	6381747	April 2002	Wonfor et al.	X
	U 0188	6385329	May 2002	Sharma et al.	X
	U 0189	6389538	May 2002	Gruse et al.	X
	U 0190	6405203	June 2002	Collart	X
	U 0191	6415041	July 2002	Oami et al.	X
	U 0192	6425081	July 2002	Iwamura	X
	U 0193	6430301	August 2002	Petrovic	X
	U 0194	6430302	August 2002	Rhoads	X
	U 0195	6442283	August 2002	Tewfik et al.	X
	U 0196	6446211	September 2002	Colvin	X
	U 0197	6453252	September 2002	Laroche	X
	U 0198	6457058	September 2002	Ullum et al.	X
	U 0199	6463468	October 2002	Buch et al.	X
	U 0200	6484264	November 2002	Colvin	X
	U 0201	6493457	December 2002	Quackenbush	X
	U 0202	6502195	December 2002	Colvin	X
	U 0203	6522767	February 2003	Moskowitz et al.	X
	U 0204	6522769	February 2003	Rhoads et al.	X
	U 0205	6523113	February 2003	Wehrenberg	X

DATE:	EXAMINER'S SIGNATURE:
-------	-----------------------

ALL REFERENCES CONSIDERED EXCEPT WHERE LINED THROUGH. //I.O./

Printed: March 20, 2015 (12:02pm)

Path: Y:\Clients\SCOT Scott A Moskowitz and Wistaria Trading,

Inc\SCOT0014-4\Drafts\ReferenceCitationList_SCOT0014-4_3-12-2015.wpd

37 CFR 1.98(a)(1)(i) APPLICATION & ATTORNEY DOCKET: 11/895,388 / SCOT0014-4

37 CFR 1.98(a)(1)(iii): THIS IS AN INFORMATION DISCLOSURE STATEMENT

EXAMINER INITIALS	REFERENCE NUMBER (U SERIES)	PATENT NUMBER	ISSUE DATE	NAME OF PATENTEE OR APPLICANT	REFERENCES CITED AND CONSIDERED BY EXAMINER IN PARENT CASE IDENTIFIED BY PLACEMENT OF "X"
	U 0206	6530021	March 2003	Epstein et al.	X
	U 0207	6532284	March 2003	Walker et al.	X
	U 0208	6539475	March 2003	Cox et al.	X
	U 0209	6557103	April 2003	Boncelet, Jr. et al.	X
	U 0210	6584125	June 2003	Katto	X
	U 0211	6587837	July 2003	Spagna et al.	X
	U 0212	6598162	July 2003	Moskowitz	X
	U 0213	6606393	August 2003	Xie et al.	X
	U 0214	6647424	November 2003	Pearson et al.	X
	U 0215	6658010	December 2003	Enns et al.	X
	U 0216	6665489	December 2003	Collart	X
	U 0217	6668246	December 2003	Yeung et al.	X
	U 0218	6668325	December 2003	Collberg et al	X
	U 0219	6687683	February 2004	Harada et al.	X
	U 0220	6725372	April 2004	Lewis et al	X
	U 0221	6754822	June 2004	Zhao	X
	U 0222	6775772	August 2004	Binding et al.	X
	U 0223	6784354	August 2004	Lu et al.	X
	U 0224	6785815	August 2004	Serret-Avila et al.	X
	U 0225	6785825	August 2004	Colvin	X
	U 0226	6792548	September 2004	Colvin	X
	U 0227	6792549	September 2004	Colvin	X
	U 0228	6795925	September 2004	Colvin	X

DATE:	EXAMINER'S SIGNATURE:
-------	-----------------------

ALL REFERENCES CONSIDERED EXCEPT WHERE LINED THROUGH. //I.O./

Printed: March 20, 2015 (12:02pm)

Path: Y:\Clients\SCOT Scott A Moskowitz and Wistaria Trading,

Inc\SCOT0014-4\Drafts\ReferenceCitationList_SCOT0014-4_3-12-2015.wpd

37 CFR 1.98(a)(1)(i) APPLICATION & ATTORNEY DOCKET: 11/895,388 / SCOT0014-4

37 CFR 1.98(a)(1)(iii): THIS IS AN INFORMATION DISCLOSURE STATEMENT

EXAMINER INITIALS	REFERENCE NUMBER (U SERIES)	PATENT NUMBER	ISSUE DATE	NAME OF PATENTEE OR APPLICANT	REFERENCES CITED AND CONSIDERED BY EXAMINER IN PARENT CASE IDENTIFIED BY PLACEMENT OF "X"
	U 0229	6799277	September 2004	Colvin	X
	U 0230	6813717	November 2004	Colvin	X
	U 0231	6813718	November 2004	Colvin	X
	U 0232	6823455	November 2004	Macy et al.	X
	U 0233	6834308	December 2004	Ikezoye et al.	X
	U 0234	6842862	January 2005	Chow et al.	X
	U 0235	6853726	February 2005	Moskowitz et al.	X
	U 0236	6857078	February 2005	Colvin	X
	U 0237	6931534	August 2005	Jandel et al.	X
	U 0238	6966002	November 2005	Torrubia-Saez	X
	U 0239	6983337	November 2005	Wold	X
	U 0240	6977894	December 2005	Achilles et al.	X
	U 0241	6978370	December 2005	Kocher	X
	U 0242	6986063	January 2006	Colvin	X
	U 0243	7007166	February 2006	Moskowitz et al.	X
	U 0244	7020285	March 2006	Kirovski et al.	X
	U 0245	7035409	April 2006	Moskowitz	X
	U 0246	7043050	May 2006	Yuval	X
	U 0247	7046808	May 2006	Metois et al.	X
	U 0248	7050396	May 2006	Cohen et al.	X
	U 0249	7051208	May 2006	Venkatesan et al.	X
	U 0250	7058570	June 2006	Yu et al.	X
	U 0251	7093295	August 2006	Saito	X

DATE:	EXAMINER'S SIGNATURE:
-------	-----------------------

ALL REFERENCES CONSIDERED EXCEPT WHERE LINED THROUGH. //I.O./

Printed: March 20, 2015 (12:02pm)

Path: Y:\Clients\SCOT Scott A Moskowitz and Wistaria Trading,

Inc\SCOT0014-4\Drafts\ReferenceCitationList_SCOT0014-4_3-12-2015.wpd

37 CFR 1.98(a)(1)(i) APPLICATION & ATTORNEY DOCKET: 11/895,388 / SCOT0014-4

37 CFR 1.98(a)(1)(iii): THIS IS AN INFORMATION DISCLOSURE STATEMENT

EXAMINER INITIALS	REFERENCE NUMBER (U SERIES)	PATENT NUMBER	ISSUE DATE	NAME OF PATENTEE OR APPLICANT	REFERENCES CITED AND CONSIDERED BY EXAMINER IN PARENT CASE IDENTIFIED BY PLACEMENT OF "X"
	U 0252	7095874	August 2006	Moskowitz et al	. X
	U 0253	7103184	September 2006	Jian	X
	U 0254	7107451	September 2006	Moskowitz	X
	U 0255	7123718	October 2006	Moskowitz et al.	X
	U 0256	7127615	October 2006	Moskowitz	X
	U 0257	7150003	December 2006	Naumovich et al.	X
	U 0258	7152162	December 2006	Moskowitz et al.	X
	U 0259	7159116	January 2007	Moskowitz	X
	U 0260	7162642	January 2007	Schumann et al.	X
	U 0261	7177429	February 2007	Moskowitz et al.	X
	U 0262	7177430	February 2007	Kim	X
	U 0263	7206649	April 2007	Kirovski et al.	X
	U 0264	7231524	June 2007	Bums	X
	U 0265	7233669.	June 2007	Candalore	X
	U 0266	7240210	July 2007	Michak et al.	X
	U 0267	7266697	September 2007	Kirovski et al	. X
	U 0268	7287275	October 2007	Moskowitz	X
	U 0269	7289643	October 2007	Brunk et al.	X
	U 0270	7343492	March 2008	Moskowitz et al.	X
	U 0271	7346472	March 2008	Moskowitz et al.	X
	U 0272	7362775	April 2008	Moskowitz	X
	U 0273	7363278	April 2008	Schmelzer et al.	X
	U 0274	7409073	August 2008	Moskowitz et al.	X

DATE:	EXAMINER'S SIGNATURE:
-------	-----------------------

ALL REFERENCES CONSIDERED EXCEPT WHERE LINED THROUGH. //I.O./

Printed: March 20, 2015 (12:02pm)

Path: Y:\Clients\SCOT Scott A Moskowitz and Wistaria Trading,

Inc\SCOT0014-4\Drafts\ReferenceCitationList_SCOT0014-4_3-12-2015.wpd

37 CFR 1.98(a)(1)(i) APPLICATION & ATTORNEY DOCKET: 11/895,388 / SCOT0014-4

37 CFR 1.98(a)(1)(iii): THIS IS AN INFORMATION DISCLOSURE STATEMENT

EXAMINER INITIALS	REFERENCE NUMBER (U SERIES)	PATENT NUMBER	ISSUE DATE	NAME OF PATENTEE OR APPLICANT	REFERENCES CITED AND CONSIDERED BY EXAMINER IN PARENT CASE IDENTIFIED BY PLACEMENT OF "X"
	U 0275	7457962	November 2008	Moskowitz	X
	U 0276	7460994	December 2008	Herre et al.	X
	U 0277	7475246	January 2009	Moskowitz	X
	U 0278	7530102	May 2009	Moskowitz	X
	U 0279	7532725	May 2009	Moskowitz et al.	X
	U 0280	7568100	July 2009	Moskowitz et al.	X
	U 0281	7647502	January 2010	Moskowitz	X
	U 0282	7647503	January 2010	Moskowitz	X
	U 0283	7779261	August 2010	Moskowitz	X
	U 0284	6990453	January 2006	Wang	X
	U 0285	6081597	June 2000	Hoffstein	X
	U 0286	7035049	Apr 2006	Yamamoto	X
	U 0287	7664263	Feb 2010	Moskowitz	X
	U 0288	7286451	Oct 2007	Wirtz	X
	U 0289	6385324	May 2002	Koppen	X
	U 0290	6674858	Jan 2004	Kimura	X
	U 0291	6148333	Nov 2000	Guedalia	X
	U 0292	6418421	Jun 2002	Hurtado	X
	U 0293	6385596	May 2002	Wiser	X
	U 0294	6226618	May 2001	Downs	X
	U 0295	6957330	Oct 2005	Hughes	X
	U 0296	5842213	Nov 1998	Odom	X
	U 0297	5818818	Oct 1998	Soumiya	X

DATE:	EXAMINER'S SIGNATURE:
-------	-----------------------

ALL REFERENCES CONSIDERED EXCEPT WHERE LINED THROUGH. //I.O./

Receipt date: 03/20/2015

11895388 - GAU: 2432

Printed: March 20, 2015 (12:02pm)

Path: Y:\Clients\SCOT Scott A Moskowitz and Wistaria Trading,

Inc\SCOT0014-4\Drafts\ReferenceCitationList_SCOT0014-4_3-12-2015.wpd

37 CFR 1.98(a)(1)(i) APPLICATION & ATTORNEY DOCKET: 11/895,388 / SCOT0014-4

37 CFR 1.98(a)(1)(iii): THIS IS AN INFORMATION DISCLOSURE STATEMENT

EXAMINER INITIALS	REFERENCE NUMBER (U SERIES)	PATENT NUMBER	ISSUE DATE	NAME OF PATENTEE OR APPLICANT	REFERENCES CITED AND CONSIDERED BY EXAMINER IN PARENT CASE IDENTIFIED BY PLACEMENT OF "X"
	U 0298	6590996	Jun 2003	Reed	X
	U 0299	5949055	Sept 1999	Fleet	X
	U 0300	6067622	May 2000	Moore	X
	U 0301	7761712	Jun 2010	Moskowitz	X
	U 0302	7743001	Jun 2010	Vermeulen	X
	U 0303	6865747	Mar 2005	Mercier	
	U 0304	6611599	Aug 2003	Natarajan	
	U 0305	6480937	Nov 2002	Vorbach	
	U 0306	6398245	Jun 2002	Gruse	
	U 0307	6950941	Sept 2005	Lee	
	U 0308	6983058	Jan 2006	Fukuoka	
	U 0309	5675653	Oct 1997	Nelson	
	U 0310	6804453	Oct 2004	Sasamoto	
	U 0311	6178405	Jan 2001	Ouyang	
	U 0312	5839100	Nov 1998	Wegener	
	U 0313	5781184	Jul 1998	Wasserman	
	U 0314	5617506	Apr 1997	Burk	
	U 0315	5327520	Jul 1994	Chen	
	U 0316	5111530	May 1992	Kutaragi	
	U 0317	7095715	Aug 2006	Buckman	
	U 0318	6173322	Jan 2001	Hu	
	U 0319	5754938	May 1998	Herz	
	U 0320	6035398	Mar 2000	Bjorn	

DATE:	EXAMINER'S SIGNATURE:
-------	-----------------------

ALL REFERENCES CONSIDERED EXCEPT WHERE LINED THROUGH. //I.O./

Printed: March 20, 2015 (12:02pm)

Path: Y:\Clients\SCOT Scott A Moskowitz and Wistaria Trading,

Inc\SCOT0014-4\Drafts\ReferenceCitationList_SCOT0014-4_3-12-2015.wpd

37 CFR 1.98(a)(1)(i) APPLICATION & ATTORNEY DOCKET: 11/895,388 / SCOT0014-4

37 CFR 1.98(a)(1)(iii): THIS IS AN INFORMATION DISCLOSURE STATEMENT

EXAMINER INITIALS	REFERENCE NUMBER (U SERIES)	PATENT NUMBER	ISSUE DATE	NAME OF PATENTEE OR APPLICANT	REFERENCES CITED AND CONSIDERED BY EXAMINER IN PARENT CASE IDENTIFIED BY PLACEMENT OF "X"
	U 0321	5901178	May 1999	Lee	
	U 0322	8214175	July 2012	Moskowitz	
	U 0323	8265278	Sept 2012	Moskowitz	
	U 0324	8161286	Nov 2010	Moskowitz	
	U 0325	8307213	Jan 2011	Moskowitz	
	U 0326	8121343	May 2012	Moskowitz	
	U 0327	5437050	Jul 1995	Lamb	
	U 0328	5123045	Jun 1992	Ostrovsky	
	U 0329	7310815	Dec 2007	Yanovsky	
	U 0330	8179846	May 2012	Dolganow	
	U 0331	7719966	May 2010	Luft	
	U 0332	7630379	Dec 2009	Morishita	
	U 0333	5949973	Sept 1999	Yarom	
	U 0334	8400566	Mar. 2013	Terry	
	U 0335	5649284	July 1997	Yoshinobu	
	U 0336	7444506	Oct 2008	Datta	
	U 0337	6480963	Oct 2002	Tachibana	
	U 0338	6510513	Jan 2003	Darrow	
	U 0339	5189411	Feb 1993	Collar	
	U 0340	5293633	Mar 1994	Robbins	
	U 0341	4633462	Dec 1986	Stifle	
	U 0342	5103461	Mar 1992	Cain	
	U 0343	6272535	Aug 2001	Iwamura	

DATE:	EXAMINER'S SIGNATURE:
-------	-----------------------

ALL REFERENCES CONSIDERED EXCEPT WHERE LINED THROUGH. //I.O./

Printed: March 20, 2015 (12:02pm)

Path: Y:\Clients\SCOT Scott A Moskowitz and Wistaria Trading,

Inc\SCOT0014-4\Drafts\ReferenceCitationList_SCOT0014-4_3-12-2015.wpd

37 CFR 1.98(a)(1)(i) APPLICATION & ATTORNEY DOCKET: 11/895,388 / SCOT0014-4

37 CFR 1.98(a)(1)(iii): THIS IS AN INFORMATION DISCLOSURE STATEMENT

EXAMINER INITIALS	REFERENCE NUMBER (U SERIES)	PATENT NUMBER	ISSUE DATE	NAME OF PATENTEE OR APPLICANT	REFERENCES CITED AND CONSIDERED BY EXAMINER IN PARENT CASE IDENTIFIED BY PLACEMENT OF "X"
	U 0344	6029195	Feb 2000	Herz	
	U 0345	8095949	Jan 2012	Hendricks	
	U 0346	5297032	Mar 1994	Trojan	
	U 0347	5644727	Jul 1997	Atkins	
	U 0348	5721781	Feb 1998	Deo	
	U 0349	5822436	Oct 1998	Rhoads	
	U 0350	5845266	Dec 1998	Lupien	
	U 0351	5864827	Jan 1999	Wilson	
	U 0352	5875437	Feb 1999	Atkins	
	U 0353	5892900	Apr 1999	Ginter	
	U 0354	6108722	Aug 2000	Troeller	
	U 0355	6029146	Feb 2000	Hawkins	
	U 0356	6032957	Mar 2000	Kiyosaki	
	U 0357	6134535	Oct 2000	Belzberg	
	U 0358	6185683	Feb 2001	Ginter	
	U 0359	6233566	May 2001	Levine	
	U 0360	6253193	Jun 2001	Ginter	
	U 0361	6272474	Aug 2001	Garcia	
	U 0362	6317728	Nov 2001	Kane	
	U 0363	6363488	Mar 2002	Ginter	
	U 0364	6389402	May 2002	Ginter	
	U 0365	6427140	Jul 2002	Ginter	
	U 0366	6484153	Nov 2002	Walker	

DATE:	EXAMINER'S SIGNATURE:
-------	-----------------------

ALL REFERENCES CONSIDERED EXCEPT WHERE LINED THROUGH. //I.O./

Printed: March 20, 2015 (12:02pm)

Path: Y:\Clients\SCOT Scott A Moskowitz and Wistaria Trading,

Inc\SCOT0014-4\Drafts\ReferenceCitationList_SCOT0014-4_3-12-2015.wpd

37 CFR 1.98(a)(1)(i) APPLICATION & ATTORNEY DOCKET: 11/895,388 / SCOT0014-4

37 CFR 1.98(a)(1)(iii): THIS IS AN INFORMATION DISCLOSURE STATEMENT

EXAMINER INITIALS	REFERENCE NUMBER (U SERIES)	PATENT NUMBER	ISSUE DATE	NAME OF PATENTEE OR APPLICANT	REFERENCES CITED AND CONSIDERED BY EXAMINER IN PARENT CASE IDENTIFIED BY PLACEMENT OF "X"
	U 0367	6556976	Aug 1987	Callen	
	U 0368	6574608	Jun 2003	Dahod	
	U 0369	6601044	Jul 2003	Wallman	
	U 0370	6594643	Jul 2003	Freeny	
	U 0371	6618188	Sep 2003	Haga	
	U 0372	6778968	Aug 2004	Gulati	
	U 0373	6839686	Jan 2005	Galant	
	U 0374	6856867	Feb 2005	Woolston	
	U 0375	6876982	Apr 2005	Lancaster	
	U 0376	7003480	Feb 2006	Fox	
	U 0377	5822436	Oct 1998	Rhoads	
	U 0378	6324649	Nov 2001	Eyres	
	U 0379	5375055	Dec 1994	Togher	
	U 0380	6018722	Jan 2000	Ray	
	U 0381	6138239	Oct 2000	Veil	
	U 0382	6484153	Nov 2002	Walker	
	U 0383	6615188	Aug 2004	Breen	
	U 0384	6856967	Jan 2005	Woolston	
	U 0385	5790783	Aug 1998	Lee	
	U 0386	6650761	Nov 2003	Rodriguez	
	U 0387	6735702	May 2004	Yavatkar	
	U 0388	6792424	Sept 2004	Burns	
	U 0389	4790564	Dec 1988	Larcher	

DATE:	EXAMINER'S SIGNATURE:
-------	-----------------------

ALL REFERENCES CONSIDERED EXCEPT WHERE LINED THROUGH. //I.O./

Printed: March 20, 2015 (12:02pm)

Path: Y:\Clients\SCOT Scott A Moskowitz and Wistaria Trading,

Inc\SCOT0014-4\Drafts\ReferenceCitationList_SCOT0014-4_3-12-2015.wpd

37 CFR 1.98(a)(1)(i) APPLICATION & ATTORNEY DOCKET: 11/895,388 / SCOT0014-4

37 CFR 1.98(a)(1)(iii): THIS IS AN INFORMATION DISCLOSURE STATEMENT

EXAMINER INITIALS	REFERENCE NUMBER (U SERIES)	PATENT NUMBER	ISSUE DATE	NAME OF PATENTEE OR APPLICANT	REFERENCES CITED AND CONSIDERED BY EXAMINER IN PARENT CASE IDENTIFIED BY PLACEMENT OF "X"
	U 0390	6111517	Aug 2000	Atick	
	U 0391	5164992	Nov 1992	Turk	
	U 0392	6674877	Jan 2004	Jojie	
	U 0393	5291560	Mar 1994	Daugman	
	U 0394	8492633	Jul 2013	Ellis	
	U 0395	7672838	Mar 2010	Ellis	
	U 0396	7254538	Aug 2007	Ellis	
	U 0397	7812241	Oct 2010	Ellis	
	U 0398	7672916	Mar 2010	Poliner	
	U 0399	5991431	Nov 1999	Borza	
	U 0400	4529870	Jul 1985	Chaum	
	U 0401	6704451	Mar 2004	Hekstra	
	U 0402	6532298	Mar 2003	Cambier	
	U 0403	8949619	Feb 2015	Parry	
	U 0404	4855584	Aug 1989	Tomiyama	
	U 0405	4749354	Jun 1988	Kerman	
	U 0406	5570339	Oct 1996	Nagano	

DATE:	EXAMINER'S SIGNATURE:
-------	-----------------------

ALL REFERENCES CONSIDERED EXCEPT WHERE LINED THROUGH. //I.O./

Printed: March 20, 2015 (12:02pm)

Path: Y:\Clients\SCOT Scott A Moskowitz and Wistaria Trading,

Inc\SCOT0014-4\Drafts\ReferenceCitationList_SCOT0014-4_3-12-2015.wpd

37 CFR 1.98(a)(1)(i) APPLICATION & ATTORNEY DOCKET: 11/895,388 / SCOT0014-4

37 CFR 1.98(a)(1)(iii): THIS IS AN INFORMATION DISCLOSURE STATEMENT

LISTING OF UNITED STATES PUBLISHED APPLICATIONS - P Series

EXAMINER INITIALS	REFERENCE NUMBER (P SERIES)	PUBLICATION NUMBER	PUBLICATION DATE	NAME OF PATENTEE OR APPLICANT	REFERENCES CITED AND CONSIDERED BY EXAMINER IN PARENT CASE IDENTIFIED BY PLACEMENT OF "X"
	P 01	20010010078	July 2001	Moskowitz	X
	P 02	20010043594	November 2001	Ogawa et al.	X
	P 03	20020010684	January 2002	Moskowitz	X
	P 04	20020026343	February 2002	Duenke	X
	P 05	20020056041	May 2002	Moskowitz	X
	P 06	20020071556	June 2002	Moskowitz et al.	X
	P 07	20020073043	June 2002	Herman et al.	X
	P 08	20020097873	July 2002	Petrovic	X
	P 09	20020103883	August 2002	Haverstock et al.	X
	P 010	20020161741	October 2002	Wang et al.	X
	P 011	20030126445	July 2003	Wehrenberg	X
	P 012	20030133702	July 2003	Collart	X
	P 013	20030200439	October 2003	Moskowitz	X
	P 014	20030219143	November 2003	Moskowitz et al.	X
	P 015	20040028222	February 2004	Sewell et al.	X
	P 016	20040037449	February 2004	Davis et al.	X
	P 017	20040049695	March 2004	Choi et al.	X
	P 018	20040059918	March 2004	Xu	X
	P 019	20040083369	April 2004	Erlingsson et al.	X
	P 020	20040086119	May 2004	Moskowitz	X
	P 021	20040093521	May 2004	Hamadeh et al.	X
	P 022	20040117628	June 2004	Colvin	X

DATE:	EXAMINER'S SIGNATURE:
-------	-----------------------

ALL REFERENCES CONSIDERED EXCEPT WHERE LINED THROUGH. //I.O./

Printed: March 20, 2015 (12:02pm)

Path: Y:\Clients\SCOT Scott A Moskowitz and Wistaria Trading,

Inc\SCOT0014-4\Drafts\ReferenceCitationList_SCOT0014-4_3-12-2015.wpd

37 CFR 1.98(a)(1)(i) APPLICATION & ATTORNEY DOCKET: 11/895,388 / SCOT0014-4

37 CFR 1.98(a)(1)(iii): THIS IS AN INFORMATION DISCLOSURE STATEMENT

EXAMINER INITIALS	REFERENCE NUMBER (P SERIES)	PUBLICATION NUMBER	PUBLICATION DATE	NAME OF PATENTEE OR APPLICANT	REFERENCES CITED AND CONSIDERED BY EXAMINER IN PARENT CASE IDENTIFIED BY PLACEMENT OF "X"
	P 023	20040117664	June 2004	Colvin	X
	P 024	20040125983	July 2004	Reed et al.	X
	P 025	20040128514.	July 2004	Rhoads	X
	P 026	20040225894	November 2004	Colvin	X
	P 027	20040243540	December 2004	Moskowitz et al.	X
	P 028	20050135615	June 2005	Moskowitz et al.	X
	P 029	20050160271	July 2005	Brundage et al.	X
	P 030	20050177727	August 2005	Moskowitz et al.	X
	P 031	20050246554	November 2005	Batson	X
	P 032	20060005029	January 2006	Petrovic et al.	X
	P 033	20060013395	January 2006	Brundage et al.	X
	P 034	20060013451	January 2006	Haitsma	X
	P 035	20060041753	February 2006	Haitsma	X
	P 036	20060101269	May 2006	Moskowitz et al.	X
	P 037	20060140403	June 2006	Moskowitz	X
	P 038	20060285722	December 2006	Moskowitz et al.	X
	P 039	20070011458	January 2007	Moskowitz	X
	P 040	20070028113	February 2007	Moskowitz	X
	P 041	20070064940	March 2007	Moskowitz et al.	X
	P 042	20070079131.	April 2007	Moskowitz et al.	X
	P 043	20070083467	April 2007	Lindahl et al.	X
	P 044	20070110240	May 2007	Moskowitz et al.	X
	P 045	20070113094	May 2007	Moskowitz et al.	X

DATE:	EXAMINER'S SIGNATURE:
-------	-----------------------

ALL REFERENCES CONSIDERED EXCEPT WHERE LINED THROUGH. //I.O./

Receipt date: 03/20/2015

11895388 - GAU: 2432

Printed: March 20, 2015 (12:02pm)

Path: Y:\Clients\SCOT Scott A Moskowitz and Wistaria Trading,

Inc\SCOT0014-4\Drafts\ReferenceCitationList_SCOT0014-4_3-12-2015.wpd

37 CFR 1.98(a)(1)(i) APPLICATION & ATTORNEY DOCKET: 11/895,388 / SCOT0014-4

37 CFR 1.98(a)(1)(iii): THIS IS AN INFORMATION DISCLOSURE STATEMENT

EXAMINER INITIALS	REFERENCE NUMBER (P SERIES)	PUBLICATION NUMBER	PUBLICATION DATE	NAME OF PATENTEE OR APPLICANT	REFERENCES CITED AND CONSIDERED BY EXAMINER IN PARENT CASE IDENTIFIED BY PLACEMENT OF "X"
	P 046	20070127717	June 2007	Herre et al.	X
	P 047	20070226506	September 2007	Moskowitz	X
	P 048	20070253594	November 2007	Lu et al.	X
	P 049	20070294536	December 2007	Moskowitz et al.	X
	P 050	20070300072	December 2007	Moskowitz	X
	P 051	20070300073	December 2007	Moskowitz	X
	P 052	20080005571	January 2008	Moskowitz	X
	P 053	20080005572	January 2008	Moskowitz	X
	P 054	20080016365	January 2008	Moskowitz	X
	P 055	20080022113	January 2008	Moskowitz	X
	P 056	20080022114	January 2008	Moskowitz	X
	P 057	20080028222	January 2008	Moskowitz	X
	P 058	20080046742	February 2008	Moskowitz	X
	P 059	20080075277	March 2008	Moskowitz et al.	X
	P 060	20080109417	May 2008	Moskowitz	X
	P 061	20080133927	June 2008	Moskowitz et al.	X
	P 062	20080151934	June 2008	Moskowitz et al.	X
	P 063	20090037740	February 2009	Moskowitz	X
	P 064	20090089427	April 2009	Moskowitz et al.	X
	P 065	20090190754	July 2009	Moskowitz et al.	X
	P 066	20090210711	August 2009	Moskowitz	X
	P 067	20090220074	September 2009	Moskowitz et al.	X
	P 068	20100002904	January 2010	Moskowitz	X

DATE:	EXAMINER'S SIGNATURE:
-------	-----------------------

ALL REFERENCES CONSIDERED EXCEPT WHERE LINED THROUGH. //I.O./

Printed: March 20, 2015 (12:02pm)

Path: Y:\Clients\SCOT Scott A Moskowitz and Wistaria Trading,

Inc\SCOT0014-4\Drafts\ReferenceCitationList_SCOT0014-4_3-12-2015.wpd

37 CFR 1.98(a)(1)(i) APPLICATION & ATTORNEY DOCKET: 11/895,388 / SCOT0014-4

37 CFR 1.98(a)(1)(iii): THIS IS AN INFORMATION DISCLOSURE STATEMENT

EXAMINER INITIALS	REFERENCE NUMBER (P SERIES)	PUBLICATION NUMBER	PUBLICATION DATE	NAME OF PATENTEE OR APPLICANT	REFERENCES CITED AND CONSIDERED BY EXAMINER IN PARENT CASE IDENTIFIED BY PLACEMENT OF "X"
	P 069	20100005308	January 2010	Moskowitz	X
	P 070	20100098251	Apr 2010	Moskowitz	X
	P 071	20100220861	Sept 2010	Moskowitz	X
	P 072	20100202607	Aug 2010	Moskowitz	X
	P 073	20020047873	June 2002	Petrovic	X
	P 074	20020009208	Jan 2002	Alattar	X
	P 075	20010029580	October 2001	Moskowitz	X
	P 076	20100182570	July 2010	Chota	X
	P 077	20100077220	March 2010	Moskowitz	X
	P 078	20100077219	March 2010	Moskowitz	X
	P 079	20100064140	March 2010	Moskowitz	X
	P 080	20100153734	June 2010	Moskowitz	X
	P 081	20100106736	April 2010	Moskowitz	X
	P 082	20060251291	November 2006	Rhoads	X
	P 083	20030002862	January 2003	Rodriguez	
	P 084	20030005780	May 2003	Hansen	
	P 085	20020152179	Oct 2002	Racov	
	P 086	20030027549	Feb 2003	Kiel	
	P 087	20020057651	May 2002	Roberts	
	P 088	20110069864	March 2011	Moskowitz	
	P 089	20100313033	Dec 2010	Moskowitz	
	P 090	20110019691	Jan 2011	Moskowitz	
	P 091	20030023852	Jan. 2003	Wold	

DATE:	EXAMINER'S SIGNATURE:
-------	-----------------------

ALL REFERENCES CONSIDERED EXCEPT WHERE LINED THROUGH. //I.O./

Printed: March 20, 2015 (12:02pm)

Path: Y:\Clients\SCOT Scott A Moskowitz and Wistaria Trading,

Inc\SCOT0014-4\Drafts\ReferenceCitationList_SCOT0014-4_3-12-2015.wpd

37 CFR 1.98(a)(1)(i) APPLICATION & ATTORNEY DOCKET: 11/895,388 / SCOT0014-4

37 CFR 1.98(a)(1)(iii): THIS IS AN INFORMATION DISCLOSURE STATEMENT

EXAMINER INITIALS	REFERENCE NUMBER (P SERIES)	PUBLICATION NUMBER	PUBLICATION DATE	NAME OF PATENTEE OR APPLICANT	REFERENCES CITED AND CONSIDERED BY EXAMINER IN PARENT CASE IDENTIFIED BY PLACEMENT OF "X"
	P 092	20030033321	Feb 2003	Schrempp	
	P 093	20130145058	June 2013	Shuholm	
	P 094	20120057012	Mar. 2012	Sitrick	
	P 095	20110128445	Jun 2011	Carrieres	
	P 096	20020188570	Dec 2002	Holliman	
	P 097	20020069174	Jun 2002	Fox	
	P 098	20130226957	Feb 27 2013	Ellis	

DATE:	EXAMINER'S SIGNATURE:
-------	-----------------------

ALL REFERENCES CONSIDERED EXCEPT WHERE LINED THROUGH. //I.O./

Printed: March 20, 2015 (12:02pm)

Path: Y:\Clients\SCOT Scott A Moskowitz and Wistaria Trading,

Inc\SCOT0014-4\Drafts\ReferenceCitationList_SCOT0014-4_3-12-2015.wpd

37 CFR 1.98(a)(1)(i) APPLICATION & ATTORNEY DOCKET: 11/895,388 / SCOT0014-4

37 CFR 1.98(a)(1)(iii): THIS IS AN INFORMATION DISCLOSURE STATEMENT

LISTING OF FOREIGN AND INTERNATIONAL PATENT DOCUMENTS - F Series

EXAMINER INITIALS	REFERENCE NUMBER (F SERIES)	PUBLICATION NUMBER	PUBLICATION DATE	COUNTRY OR REGION	PAGE/LINE AND FIGURE/ELEMENT OF RELEVANT MATERIAL	REFERENCES CITED AND CONSIDERED BY EXAMINER IN PARENT CASE IDENTIFIED BY PLACEMENT OF "X"
	F 01-	EP0372601	Jun., 1990	EP		X
	F 02-	EP0565947	Oct., 1993	EP		X
	F 03-	EP0581317	Feb., 1994	EP		X
	F 04-	EP0649261	Apr., 1995	EP		X
	F 05-	EP0651554	May., 1995	EP		X
	F 06-	EP1354276	Dec., 2007	EP		X
	F 07-	NL 1005523	Sep., 1998	NL		X
	F 08-	WO 9514289	May., 1995	WO		X
	F 09-	WO 9629795	Sep., 1996	WO		X
	F 010-	WO 9724833	Jul., 1997	WO		X
	F 011-	WO 9744736	Nov., 1997	WO		X
	F 012-	WO9837513	Aug., 1998	WO		X
	F 013-	WO 9952271	Oct., 1999	WO		X
	F 014-	WO 9962044	Dec., 1999	WO		X
	F 015-	WO 9963443	Dec., 1999	WO		X
	F 016-	WO9726733	Jan. 1997	WO		X
	F 017-	WO98002864	Jul. 1997	WO		X
	F 018-	WO 0057643	Sept 2000	WO		X
	F 019-	WO 9642151	Dec 1996	WO		X
	F 020-	EP0872073	July 1996	EP		X
	F 021-	WO0118628	March 2001	WO		X
	F 022-	WO0143026	June 2001	WO		X

DATE:	EXAMINER'S SIGNATURE:
-------	-----------------------

ALL REFERENCES CONSIDERED EXCEPT WHERE LINED THROUGH. //I.O./

Receipt date: 03/20/2015

11895388 - GAU: 2432

Printed: March 20, 2015 (12:02pm)

Path: Y:\Clients\SCOT Scott A Moskowitz and Wistaria Trading,

Inc\SCOT0014-4\Drafts\ReferenceCitationList_SCOT0014-4_3-12-2015.wpd

37 CFR 1.98(a)(1)(i) APPLICATION & ATTORNEY DOCKET: 11/895,388 / SCOT0014-4

37 CFR 1.98(a)(1)(iii): THIS IS AN INFORMATION DISCLOSURE STATEMENT

EXAMINER INITIALS	REFERENCE NUMBER (F SERIES)	PUBLICATION NUMBER	PUBLICATION DATE	COUNTRY OR REGION	PAGE/LINE AND FIGURE/ELEMENT OF RELEVANT MATERIAL	REFERENCES CITED AND CONSIDERED BY EXAMINER IN PARENT CASE IDENTIFIED BY PLACEMENT OF "X"
	F 023-	WO0203385	Jan 2002	WO		X
	F 024-	WO9701892	June 1995	WO		X
	F 025-	WO9726732	July 1997	WO		X
	F 026-	WO9802864	Jan 1998	WO		X
	F 027-	EP1547337	Mar 2006	EP		X
	F 028-	EP0581317A2	Feb 1994	EP		X
	F 029-	WO023385A1	Oct 2002	WO		X

DATE:	EXAMINER'S SIGNATURE:
-------	-----------------------

ALL REFERENCES CONSIDERED EXCEPT WHERE LINED THROUGH. //I.O./

Printed: March 20, 2015 (12:02pm)

Path: Y:\Clients\SCOT Scott A Moskowitz and Wistaria Trading,

Inc\SCOT0014-4\Drafts\ReferenceCitationList_SCOT0014-4_3-12-2015.wpd

37 CFR 1.98(a)(1)(i) APPLICATION & ATTORNEY DOCKET: 11/895,388 / SCOT0014-4

37 CFR 1.98(a)(1)(iii): THIS IS AN INFORMATION DISCLOSURE STATEMENT

LISTING OF NON PATENT LITERATURE - L Series

EXAMINER INITIAL	REF. NO. (L series)	REFERENCE NUMBER (L Series)	PUB. DATE	INCLUDE IN SEQUENCE: Name of first author (in CAPITAL LETTERS), Title in quotation marks, name of publication, date or publication, page numbers, publisher, city of publication, and country of publication NOTE - For US patent applications listed herein, if a	REFERENCES CITED AND CONSIDERED BY EXAMINER IN PARENT CASE IDENTIFIED BY PLACEMENT OF "X"
	1	L- 01	N/A	US. Appl. No. 08/999,766, filed Jul. 23, 1997, entitled "Steganographic Method and Device", published as 7568100 07-28-2009, cited as U280.	X
	2	L- 02	N/A	EPO Application No. 96919405.9, entitled "Steganographic Method and Device"; published as EP0872073 (A2), 10-21-1998, cited herein as F20.	X
	3	L- 03	N/A	U.S. Appl. No. 11/050,779, filed Feb. 7, 2005, entitled "Steganographic Method and Device", published as 20050177727 A1 08-11-2005, cited herein as P30.	X
	4	L- 04	N/A	U.S. Appl. No. 08/674,726, filed Jul. 2, 1996, entitled "Exchange Mechanisms for Digital Information Packages with Bandwidth Securitization, Multichannel Digital Watermarks, and Key Management", published as 7362775 04-22-2008, cited herein as U272 .	X
	5	L- 05	N/A	U.S. Appl. No. 09/545,589, filed Apr. 7, 2000, entitled "Method and System for Digital Watermarking", published as 7007166 02-28-2006, cited herein as U243	X
	6	L- 06	N/A	U.S. Appl. No. 11/244,213, filed Oct. 5, 2005, entitled "Method and System for Digital Watermarking", published as 2006-0101269 A1 05-11-2006, cited herein as P36	X
	7	L- 07	N/A	U.S. Appl. No. 11/649,026, filed Jan. 3, 2007, entitled "Method and System for Digital Watermarking", published as 2007-0113094 A1 05-17-2007, cited herein as P45.	X
	8	L- 08	N/A	U.S. Appl. No. 09/046,627, filed Mar. 24, 1998, entitled "Method for Combining Transfer Function with Predetermined Key Creation", published as 6,598,162 07-22-2003, cited herein as U212.	X
	9	L- 09	N/A	U.S. Appl. No. 10/602,777, filed Jun. 25, 2003, entitled "Method for Combining Transfer Function with Predetermined Key Creation", published as 2004-0086119 A1 05-06-2004, cited herein P20.	X

DATE:	EXAMINER'S SIGNATURE:
-------	-----------------------

ALL REFERENCES CONSIDERED EXCEPT WHERE LINED THROUGH. //I.O./

Printed: March 20, 2015 (12:02pm)

Path: Y:\Clients\SCOT Scott A Moskowitz and Wistaria Trading,

Inc\SCOT0014-4\Drafts\ReferenceCitationList_SCOT0014-4_3-12-2015.wpd

37 CFR 1.98(a)(1)(i) APPLICATION & ATTORNEY DOCKET: 11/895,388 / SCOT0014-4

37 CFR 1.98(a)(1)(iii): THIS IS AN INFORMATION DISCLOSURE STATEMENT

EXAMINER INITIAL	REF. NO. (L series)	REFERENCE NUMBER (L Series)	PUB. DATE	INCLUDE IN SEQUENCE: Name of first author (in CAPITAL LETTERS), Title in quotation marks, name of publication, date or publication, page numbers, publisher, city of publication, and country of publication NOTE - For US patent applications listed herein, if a	REFERENCES CITED AND CONSIDERED BY EXAMINER IN PARENT CASE IDENTIFIED BY PLACEMENT OF "X"
	10	L- 010	N/A	U.S. Appl. No. 09/053,628, filed Apr. 2, 1998, entitled "Multiple Transform Utilization and Application for Secure Digital Watermarking", 6,205,249 03-20-2001, cited herein as U161.	X
	11	L- 011	N/A	U.S. Appl. No. 09/644,098, filed Aug. 23, 2000, entitled "Multiple Transform Utilization and Application for Secure Digital Watermarking", published as 7,035,409 04-25-2006, cited herein as U245.	X
	12	L- 012	N/A	Jap. App. No. 2000-542907, entitled "Multiple Transform Utilization and Application for Secure Digital Watermarking"; which is a JP national stage of PCT/US1999/007262, published as WO/1999/052271, 10/14/1999, F13 here in above..	X
	13	L- 013	N/A	U.S. Appl. No. 09/767,733, filed Jan. 24, 2001 entitled "Multiple Transform Utilization and Application for Secure Digital Watermarking", published as 2001-0010078 A1 07-26-2001, cited herein as P1.	X
	14	L- 014	N/A	U.S. Appl. No. 11/358,874, filed Feb. 21, 2006, entitled "Multiple Transform Utilization and Application for Secure Digital Watermarking", published as 2006-0140403 A1 06-29-2006, cited herein as P37.	X
	15	L- 015	N/A	U.S. Appl. No. 10/417,231, filed Apr. 17, 2003, entitled "Methods, Systems And Devices For Packet Watermarking And Efficient Provisioning Of Bandwidth", published as 2003-0200439 A1 10-23-2003, cited herein as P13,	X
	16	L- 016	N/A	U.S. Appl. No. 09/789,711, filed Feb. 22, 2001, entitled "Optimization Methods for the Insertion, Protection, and Detection of Digital Watermarks in Digital Data", published as 2001-0029580 A1 10-11-2001, cited herein as P75.	X
	17	L- 017	N/A	U.S. Appl. No. 11/497,822, filed Aug. 2, 2006, entitled "Optimization Methods for the Insertion, Protection, and Detection of Digital Watermarks in Digital Data", published as 2007-0011458 A1 01-11-2007, cited herein as P39.	X

DATE:	EXAMINER'S SIGNATURE:
-------	-----------------------

ALL REFERENCES CONSIDERED EXCEPT WHERE LINED THROUGH. //I.O./

Printed: March 20, 2015 (12:02pm)

Path: Y:\Clients\SCOT Scott A Moskowitz and Wistaria Trading,

Inc\SCOT0014-4\Drafts\ReferenceCitationList_SCOT0014-4_3-12-2015.wpd

37 CFR 1.98(a)(1)(i) APPLICATION & ATTORNEY DOCKET: 11/895,388 / SCOT0014-4

37 CFR 1.98(a)(1)(iii): THIS IS AN INFORMATION DISCLOSURE STATEMENT

EXAMINER INITIAL	REF. NO. (L series)	REFERENCE NUMBER (L Series)	PUB. DATE	INCLUDE IN SEQUENCE: Name of first author (in CAPITAL LETTERS), Title in quotation marks, name of publication, date or publication, page numbers, publisher, city of publication, and country of publication NOTE - For US patent applications listed herein, if a	REFERENCES CITED AND CONSIDERED BY EXAMINER IN PARENT CASE IDENTIFIED BY PLACEMENT OF "X"
	18	L- 018	N/A	U.S. Appl. No. 11/599,964, filed Nov. 15, 2006, entitled "Optimization Methods for the Insertion, Protection, and Detection of Digital Watermarks in Digital Data", published as 2008-0046742 A1 02-21-2008, cited herein as P58.	X
	19	L- 019	N/A	U.S. Appl. No. 11/599,838, filed Nov. 15, 2006, entitled "Optimization Methods for the Insertion, Protection, and Detection of Digital Watermarks in Digital Data", published as 2007-0226506 A1 09-27-2007, cited herein as P47.	X
	20	L- 020	N/A	U.S. Appl. No. 10/369,344, filed Feb. 18, 2003, entitled "Optimization Methods for the Insertion, Protection, and Detection of Digital Watermarks in Digitized Data", published as 2003-0219143 A1 11-27-2003, cited herein as P14.	X
	21	L- 021	N/A	U.S. Appl. No. 11/482,654, filed Jul. 7, 2006, entitled "Optimization Methods for the Insertion, Protection, and Detection of Digital Watermarks in Digitized Data", published as 2006-0285722 A1 12-21-2006, cited herein as P38.	X
	22	L- 022	N/A	U.S. Appl. No. 09/594,719, filed Jun. 16, 2000, entitled "Utilizing Data Reduction in Steganographic and Cryptographic Systems", published as 7,123,718 10-17-2006, cited herein as U255.	X
	23	L- 023	N/A	U.S. Appl. No. 11/519,467, filed Sep. 12, 2006, entitled "Utilizing Data Reduction in Steganographic and Cryptographic Systems", published as 2007-0064940 A1 03-22-2007, cited herein as P41.	X
	24	L- 024	N/A	U.S. Appl. No. 09/731,040, filed Dec. 7, 2000, entitled "Systems, Methods And Devices For Trusted Transactions", 2002-0010684 A1 01-24-2002, cited herein as P3.	X
	25	L- 025	N/A	U.S. Appl. No. 11/512,701, filed Aug. 29, 2006, entitled "Systems, Methods And Devices For Trusted Transactions", published as 2007-0028113 A1 02-01-2007, cited herein as P40.	X

DATE:	EXAMINER'S SIGNATURE:
-------	-----------------------

ALL REFERENCES CONSIDERED EXCEPT WHERE LINED THROUGH. //I.O./

Printed: March 20, 2015 (12:02pm)

Path: Y:\Clients\SCOT Scott A Moskowitz and Wistaria Trading,

Inc\SCOT0014-4\Drafts\ReferenceCitationList_SCOT0014-4_3-12-2015.wpd

37 CFR 1.98(a)(1)(i) APPLICATION & ATTORNEY DOCKET: 11/895,388 / SCOT0014-4

37 CFR 1.98(a)(1)(iii): THIS IS AN INFORMATION DISCLOSURE STATEMENT

EXAMINER INITIAL	REF. NO. (L series)	REFERENCE NUMBER (L Series)	PUB. DATE	INCLUDE IN SEQUENCE: Name of first author (in CAPITAL LETTERS), Title in quotation marks, name of publication, date or publication, page numbers, publisher, city of publication, and country of publication NOTE - For US patent applications listed herein, if a	REFERENCES CITED AND CONSIDERED BY EXAMINER IN PARENT CASE IDENTIFIED BY PLACEMENT OF "X"
	26	L- 026	N/A	U.S. Appl. No. 10/049,101, filed Feb. 8, 2002, entitled "A Secure Personal Content Server", published as 7,475,246 01-06-2009, cited herein as U277.	X
	27	L- 027	N/A	PCT Application No. PCT/US00/21189, filed Aug. 4, 2000, entitled, "A Secure Personal Content Server", Pub. No.: WO/2001/018628 ; Publication Date: 15.03.2001, cited herein as F21.	X
	28	L- 028	N/A	U.S. Appl. No. 09/657,181, filed Sep. 7, 2000, entitled "Method and Device For Monitoring And Analyzing Signals", published as 7,346,472 03-18-2008, cited herein as U271.	X
	29	L- 029	N/A	U.S. Appl. No. 10/805,484, filed Mar. 22, 2004, entitled "Method And Device For Monitoring And Analyzing Signals", published as 2004-0243540 A1 12-02-2004, cited herein as P27.	X
	30	L- 030	N/A	U.S. Appl. No. 09/956,262, filed Sep. 20, 2001, entitled "Improved Security Based on Subliminal and Supraliminal Channels For Data Objects", published as 2002-0056041 A1 05-09-2002, cited herein as P05	X
	31	L- 031	N/A	U.S. Appl. No. 11/518,806, filed Sep. 11, 2006, entitled "Improved Security Based on Subliminal and Supraliminal Channels For Data Objects", 2008-0028222 A1 01-31-2008, cited herein as P57.	X
	32	L- 032	N/A	U.S. Appl. No. 11/026,234, filed Dec. 30, 2004, entitled "Z-Transform Implementation of Digital Watermarks" , published as 2005-0135615 A1 06-23-2005, cited herein as P28.	X
	33	L- 033	N/A	U.S. Appl. No. 11/592,079, filed Nov. 2, 2006, entitled "Linear Predictive Coding Implementation of Digital Watermarks", published as 2007-0079131 A1 04-05-2007, cited herein as P42.	X

DATE:	EXAMINER'S SIGNATURE:
-------	-----------------------

ALL REFERENCES CONSIDERED EXCEPT WHERE LINED THROUGH. //I.O./

Printed: March 20, 2015 (12:02pm)

Path: Y:\Clients\SCOT Scott A Moskowitz and Wistaria Trading,

Inc\SCOT0014-4\Drafts\ReferenceCitationList_SCOT0014-4_3-12-2015.wpd

37 CFR 1.98(a)(1)(i) APPLICATION & ATTORNEY DOCKET: 11/895,388 / SCOT0014-4

37 CFR 1.98(a)(1)(iii): THIS IS AN INFORMATION DISCLOSURE STATEMENT

EXAMINER INITIAL	REF. NO. (L series)	REFERENCE NUMBER (L Series)	PUB. DATE	INCLUDE IN SEQUENCE: Name of first author (in CAPITAL LETTERS), Title in quotation marks, name of publication, date or publication, page numbers, publisher, city of publication, and country of publication NOTE - For US patent applications listed herein, if a	REFERENCES CITED AND CONSIDERED BY EXAMINER IN PARENT CASE IDENTIFIED BY PLACEMENT OF "X"
	34	L- 034	N/A	U.S. Appl. No. 09/731,039, filed Dec. 7, 2000, entitled "System and Methods for Permitting Open Access to Data Objects and for Securing Data within the Data Objects", published as 2002-0071556 A1 06-13-2002, cited herein as P06.	X
	35	L- 035	N/A	U.S. Appl. No. 11/647,861, filed Dec. 29, 2006, entitled "System and Methods for Permitting Open Access to Data Objects and for Securing Data within the Data Objects", published as 2007-0110240 A1 05-17-2007, cited herein as P44.	X
	36	L- 036	1996	Schneier, Bruce, Applied Cryptography, 2nd Ed., John Wiley & Sons, pp. 9-10, 1996.	X
	37	L- 037	1997	Menezes, Alfred J., Handbook of Applied Cryptography, CRC Press, p. 46, 1997.	X
	38	L- 038	1997	Merriam-Webster's Collegiate Dictionary, 10th Ed., Merriam Webster, Inc., p. 207.	X
	39	L- 039	1984	Brealy, et al., Principles of Corporate Finance, "Appendix A--Using Option Valuation Models", 1984, pp. 448-449.	X
	40	L- 040	2001	Copeland, et al., Real Options: A Practitioner's Guide, 2001 pp. 106-107, 201-202, 204-208.	X
	41	L- 041	1995	Sarkar, M. "An Assessment of Pricing Mechanisms for the Internet-A Regulatory Imperative", presented MIT Workshop on Internet Economics, Mar. 1995 http://www.press.vmich.edu/iep/works/SarkAsses.html on.	X
	42	L- 042	1995	Crawford, D.W. "Pricing Network Usage: A Market for Bandwidth of Market Communication?" presented MIT Workshop on Internet Economics, Mar. 1995 http://www.press.vmich.edu/iep/works/CrawMarket.html on March.	X
	43	L- 043	1988	Low, S.H., "Equilibrium Allocation and Pricing of Variable Resources Among User-Suppliers", 1988. http://www.citeseer.nj.nec.com/366503.html .	X

DATE:	EXAMINER'S SIGNATURE:
-------	-----------------------

ALL REFERENCES CONSIDERED EXCEPT WHERE LINED THROUGH. //I.O./

Printed: March 20, 2015 (12:02pm)

Path: Y:\Clients\SCOT Scott A Moskowitz and Wistaria Trading,

Inc\SCOT0014-4\Drafts\ReferenceCitationList_SCOT0014-4_3-12-2015.wpd

37 CFR 1.98(a)(1)(i) APPLICATION & ATTORNEY DOCKET: 11/895,388 / SCOT0014-4

37 CFR 1.98(a)(1)(iii): THIS IS AN INFORMATION DISCLOSURE STATEMENT

EXAMINER INITIAL	REF. NO. (L series)	REFERENCE NUMBER (L Series)	PUB. DATE	INCLUDE IN SEQUENCE: Name of first author (in CAPITAL LETTERS), Title in quotation marks, name of publication, date or publication, page numbers, publisher, city of publication, and country of publication NOTE - For US patent applications listed herein, if a	REFERENCES CITED AND CONSIDERED BY EXAMINER IN PARENT CASE IDENTIFIED BY PLACEMENT OF "X"
	44	L- 044	1995	Caronni, Germano, "Assuring Ownership Rights for Digital Images", published proceeds of reliable IT systems, v15 '95, H.H. Bruggemann and W. Gerhardt-Hackel (Ed) Viewing Publishing Company Germany 1995.	X
	45	L- 045	1996	Zhao, Jian. "A WWW Service to Embed and Prove Digital Copyright Watermarks", Proc. of the European conf. on Multimedia Applications, Services & Techniques Louvain-La-Neuve Belgium May 1996.	X
	46	L- 046	1996	Gruhl, Daniel et al., Echo Hiding. In Proceeding of the Workshop on Information Hiding. No. 1174 in Lecture Notes in Computer Science, Cambridge, England (May/Jun. 1996).	X
	47	L- 047	1995	Oomen, A.W.J. et al., A Variable Bit Rate Buried Data Channel for Compact Disc, J.AudioEng. Sc., vol. 43, No. 1/2, pp. 23-28 (1995).	X
	48	L- 048	1992	Ten Kate, W. et al., A New Surround-Stereo-Surround Coding Techniques, J. Audio Eng.Soc., vol. 40,No. 5,pp. 376-383 (1992).	X
	49	L- 049	1993	Gerzon, Michael et al., A High Rate Buried Data Channel for Audio CD, presentation notes, Audio Engineering Soc. 94th Convention (1993).	X
	50	L- 050	1988	Sklar, Bernard, Digital Communications, pp. 601-603 (1988).	X
	51	L- 051	1984	Jayant, N.S. et al., Digital Coding of Waveforms, Prentice Hall Inc., Englewood Cliffs, NJ, pp. 486-509 (1984)	X
	52	L- 052	1995	Bender, Walter R. et al., Techniques for Data Hiding, SPIE Int. Soc. Opt. Eng., vol. 2420, pp. 164-173, 1995.	X
	53	L- 053	1995	Zhao, Jian et al., Embedding Robust Labels into Images for Copyright Protection, (xp 000571976), pp. 242-251, 1995.	X
	54	L- 054	1997	Menezes, Alfred J., Handbook of Applied Cryptography, CRC Press, p. 175, 1997.	X

DATE:	EXAMINER'S SIGNATURE:
-------	-----------------------

ALL REFERENCES CONSIDERED EXCEPT WHERE LINED THROUGH. //I.O./

Printed: March 20, 2015 (12:02pm)

Path: Y:\Clients\SCOT Scott A Moskowitz and Wistaria Trading,

Inc\SCOT0014-4\Drafts\ReferenceCitationList_SCOT0014-4_3-12-2015.wpd

37 CFR 1.98(a)(1)(i) APPLICATION & ATTORNEY DOCKET: 11/895,388 / SCOT0014-4

37 CFR 1.98(a)(1)(iii): THIS IS AN INFORMATION DISCLOSURE STATEMENT

EXAMINER INITIAL	REF. NO. (L series)	REFERENCE NUMBER (L Series)	PUB. DATE	INCLUDE IN SEQUENCE: Name of first author (in CAPITAL LETTERS), Title in quotation marks, name of publication, date or publication, page numbers, publisher, city of publication, and country of publication NOTE - For US patent applications listed herein, if a	REFERENCES CITED AND CONSIDERED BY EXAMINER IN PARENT CASE IDENTIFIED BY PLACEMENT OF "X"
	55	L- 055	1994	Schneier, Bruce, Applied Cryptography, 1st Ed., pp. 67-68, 1994.	X
	56	L- 056	1990	Ten Kate, W. et al., "Digital Audio Carrying Extra Information", IEEE, CH 2847-2/90/0000-1097, (1990).	X
	57	L- 057	1994	Van Schyndel, et al., "A digital Watermark," IEEE Int'l Computer Processing Conference, Austin, TX, Nov. 13-16, 1994, pp. 86-90.	X
	58	L- 058	1996	Smith, et al. "Modulation and Information Hiding in Images", Springer Verlag, 1st Int'l Workshop, Cambridge, UK, May 30-Jun. 1, 1996, pp. 207-227.	X
	59	L- 059	1997	Kutter, Martin et al., "Digital Signature of Color Images Using Amplitude Modulation", SPIE-E197, vol. 3022, pp. 518-527.	X
	60	L- 060	1997	Puate, Joan et al., "Using Fractal Compression Scheme to Embed a Digital Signature into an Image", SPIE-96 Proceedings, vol. 2915, Mar. 1997, pp. 108-118.	X
	61	L- 061	1996	Swanson, Mitchell D., et al., "Transparent Robust Image Watermarking", Proc. of the 1996 IEEE Int'l Conf. on Image Processing, vol. 111, 1996, pp. 211-214.	X
	62	L- 062	1996	Swanson, Mitchell D., et al. "Robust Data Hiding for Images", 7th IEEE Digital Signal Processing Workshop, Leon, Norway. Sep. 1-4, 1996, pp. 37-40.	X
	63	L- 063	Unknown	Zhao, Jian et al., "Embedding Robust Labels into Images for Copyright Protection", Proceeding of the Know Right '95 Conference, pp. 242-251.	X
	64	L- 064	1995	Koch, E., et al., "Towards Robust and Hidden Image Copyright Labeling", 1995 IEEE Workshop on Nonlinear Signal and Image Processing, Jun. 1995 Neos Marmaras pp. 4.	X
	65	L- 065	1995	Van Schyndel, et al., "Towards a Robust Digital Watermark", Second Asian Image Processing Conference, Dec. 6-8, 1995, Singapore, vol. 2, pp. 504-508.	X

DATE:	EXAMINER'S SIGNATURE:
-------	-----------------------

ALL REFERENCES CONSIDERED EXCEPT WHERE LINED THROUGH. //I.O./

Printed: March 20, 2015 (12:02pm)

Path: Y:\Clients\SCOT Scott A Moskowitz and Wistaria Trading,

Inc\SCOT0014-4\Drafts\ReferenceCitationList_SCOT0014-4_3-12-2015.wpd

37 CFR 1.98(a)(1)(i) APPLICATION & ATTORNEY DOCKET: 11/895,388 / SCOT0014-4

37 CFR 1.98(a)(1)(iii): THIS IS AN INFORMATION DISCLOSURE STATEMENT

EXAMINER INITIAL	REF. NO. (L series)	REFERENCE NUMBER (L Series)	PUB. DATE	INCLUDE IN SEQUENCE: Name of first author (in CAPITAL LETTERS), Title in quotation marks, name of publication, date or publication, page numbers, publisher, city of publication, and country of publication NOTE - For US patent applications listed herein, if a	REFERENCES CITED AND CONSIDERED BY EXAMINER IN PARENT CASE IDENTIFIED BY PLACEMENT OF "X"
	66	L- 066	1995	Tirkel,A.Z., "A Two-Dimensional Digital Watermark", DICTA '95, Univ. of Queensland, Brisbane, Dec. 5-8, 1995, pp. 7.	X
	67	L- 067	1996	Tirkel,A.Z., "Image Watermarking--A Spread Spectrum Application", ISSSTA '96, Sep. 1996, Mainz, German, pp. 6.	X
	68	L- 068	1996	O'Ruanaidh, et al. "Watermarking Digital Images for Copyright Protection", IEEE Proceedings, vol. 143, No. 4, Aug. 1996, pp. 250-256.	X
	69	L- 069	Unknown	Cox, et al., Secure Spread Spectrum Watermarking for Multimedia, NEC Research Institute, Techinal Report 95-10, pp. 33.	X
	70	L- 070	1969	Kahn, D., "The Code Breakers", The MacMillan Company, 1969, pp. xIII, 81-83, 513, 515, 522-526, 863.	X
	71	L- 071	1997	Boney, et al., Digital Watermarks for Audio Signals, EVSIPCO, 96, pp. 473-480 (3/14/1997).	X
	72	L- 072	1996	Dept. of Electrical Engineering, Del Ft University of Technology, Del ft The Netherlands, Cr.C. Langelaar et al., "Copy Protection for Multimedia Data based on Labeling Techniques", Jul. 1996 9 pp.	X
	73	L- 073	Unknown	F. Hartung, et al., "Digital Watermarking of Raw and Compressed Video", SPIE vol. 2952, pp. 205-213.	X
	74	L- 074	1996	Craver, et al., "Can Invisible Watermarks Resolve Rightful Ownerships?", IBM Research Report, RC 20509 (Jul. 25, 1996) 21 pp.	X
	75	L- 075	1988	Press, et al., "Numerical Recipes in C", Cambridge Univ. Press, 1988, pp. 398-417.	X
	76	L- 076	1995	Pohlmann, Ken C., "Principles of Digital Audio", 3rd Ed., 1995, pp. 32-37, 40-48:138, 147-149, 332, 333, 364, 499-501, 508-509, 564-571.	X
	77	L- 077	1991	Pohlmann, Ken C., "Principles of Digital Audio", 2nd Ed., 1991, pp. 1-9, 19-25, 30-33, 41-48, 54-57, 86-107, 375-387.	X

DATE:	EXAMINER'S SIGNATURE:
-------	-----------------------

ALL REFERENCES CONSIDERED EXCEPT WHERE LINED THROUGH. //I.O./

Printed: March 20, 2015 (12:02pm)

Path: Y:\Clients\SCOT Scott A Moskowitz and Wistaria Trading,

Inc\SCOT0014-4\Drafts\ReferenceCitationList_SCOT0014-4_3-12-2015.wpd

37 CFR 1.98(a)(1)(i) APPLICATION & ATTORNEY DOCKET: 11/895,388 / SCOT0014-4

37 CFR 1.98(a)(1)(iii): THIS IS AN INFORMATION DISCLOSURE STATEMENT

EXAMINER INITIAL	REF. NO. (L series)	REFERENCE NUMBER (L Series)	PUB. DATE	INCLUDE IN SEQUENCE: Name of first author (in CAPITAL LETTERS), Title in quotation marks, name of publication, date or publication, page numbers, publisher, city of publication, and country of publication NOTE - For US patent applications listed herein, if a	REFERENCES CITED AND CONSIDERED BY EXAMINER IN PARENT CASE IDENTIFIED BY PLACEMENT OF "X"
	78	L- 078	1994	Schneier, Bruce, Applied Cryptography, John Wiley & Sons, Inc., New York, 1994, pp. 68, 69, 387-392, 1-57, 273-275, 321-324.	X
	79	L- 079	1996	Boney, et al., Digital Watermarks for Audio Signals, Proceedings of the International Conf. on Multimedia Computing and Systems, Jun. 17-23, 1996 Hiroshima, Japan, 0-8186-7436-9196, pp. 473-480.	X
	80	L- 080	1998	Johnson, et al., "Transform Permuted Watermarking for Copyright Protection of Digital Video", IEEE Globecom 1998, Nov. 8-12, 1998, New York New York vol. 2 1998 pp. 684-689 (ISBN 0-7803-4985-7).	X
	81	L- 081	1996	Rivest, et al., "Pay Word and Micromint: Two Simple Micropayment Schemes," MIT Laboratory for Computer Science, Cambridge, MA, May 7, 1996 pp. 1-18.	X
	82	L- 082	1996	Bender, et al., "Techniques for Data Hiding", IBM Systems Journal, (1996) vol. 35, Nos. 3 & 4, 1996, pp. 313-336.	X
	83	L- 083	2003	Moskowitz, "Bandwith as Currency", IEEE Multimedia, Jan.-Mar. 2003, pp. 14-21.	X
	84	L- 084	2006	Moskowitz, Multimedia Security Technologies for Digital Rights Management, 2006, Academic Press, "Introduction--Digital Rights Management" pp. 3-22.	X
	85	L- 085	2001	Rivest, et al., "PayWord and Micromint: Two Simple Micropayment Schemes," MIT Laboratory for Computer Science, Cambridge, MA, Apr. 27, 2001, pp. 1-18.	X
	86	L- 086	2000	Tomsich, et al., "Towards a secure and de-centralized digital watermarking infrastructure for the protection of Intellectual Property", in Electronic Commerce and Web Technologies, Proceedings (ECWEB)(2000).	X
	87	L- 087	2002	Moskowitz, "What is Acceptable Quality in the Application of Digital Watermarking: Trade-offs of Security; Robustness and Quality", IEEE Computer Society Proceedings of ITCC 2002 Apr. 10, 2002 pp. 80-84.	X

DATE:	EXAMINER'S SIGNATURE:
-------	-----------------------

ALL REFERENCES CONSIDERED EXCEPT WHERE LINED THROUGH. //I.O./

Printed: March 20, 2015 (12:02pm)

Path: Y:\Clients\SCOT Scott A Moskowitz and Wistaria Trading,

Inc\SCOT0014-4\Drafts\ReferenceCitationList_SCOT0014-4_3-12-2015.wpd

37 CFR 1.98(a)(1)(i) APPLICATION & ATTORNEY DOCKET: 11/895,388 / SCOT0014-4

37 CFR 1.98(a)(1)(iii): THIS IS AN INFORMATION DISCLOSURE STATEMENT

EXAMINER INITIAL	REF. NO. (L series)	REFERENCE NUMBER (L Series)	PUB. DATE	INCLUDE IN SEQUENCE: Name of first author (in CAPITAL LETTERS), Title in quotation marks, name of publication, date or publication, page numbers, publisher, city of publication, and country of publication NOTE - For US patent applications listed herein, if a	REFERENCES CITED AND CONSIDERED BY EXAMINER IN PARENT CASE IDENTIFIED BY PLACEMENT OF "X"
	88	L- 088	2006	Lemma, et al. "Secure Watermark Embedding through Partial Encryption", International Workshop on Digital Watermarking ("IWDW" 2006). Springer Lecture Notes in Computer Science 2006 (to appear) 13.	X
	89	L- 089	2002	Kocher, et al., "Self Protecting Digital Content", Technical Report from the CRI Content Security Research Initiative, Cryptography Research, Inc. 2002-2003 14 pages.	X
	90	L- 090	1995	Sirbu, M. et al., "Net Bill: An Internet Commerce System Optimized for Network Delivered Services", Digest of Papers of the Computer Society Computer Conference (Spring) Mar. 5, 1995 pp. 20-25 vol. CONF40.	X
	91	L- 091	1998	Schunter, M. et al., "A Status Report on the SEMPER framework for Secure Electronic Commerce", Computer Networks and ISDN Systems, Sep. 30, 1998, pp. 1501-1510 vol. 30 No. 16-18 NL North Holland.	X
	92	L- 092	1999	Konrad, K. et al., "Trust and Electronic Commerce--more than a technical problem," Proceedings of the 18th IEEE Symposium on Reliable Distributed Systems Oct. 19-22, 1999, pp. 360-365 Lausanne.	X
	93	L- 093	1998	Kini, et al., "Trust in Electronic Commerce: Definition and Theoretical Considerations", Proceedings of the 31st Hawaii Int'l Conf on System Sciences (Cat. No. 98TB100216). Jan. 6-9, 1998. pp. 51-61. Los.	X
	94	L- 094	1997	Steinauer D. D., et al., "Trust and Traceability in Electronic Commerce", Standard View, Sep. 1997, pp. 118-124, vol. 5 No. 3, ACM, USA.	X
	95	L- 095	1999	Hartung, et al. "Multimedia Watermarking Techniques", Proceedings of the IEEE, Special Issue, Identification & Protection of Multimedia Information, pp. 1079-1107 Jul. 1999 vol. 87 No. 7 IEEE.	X
	96	L- 096	N/A	European Search Report & European Search Opinion in EP07112420	X
	97	L- 097	2006	STAIND (The Singles 1996-2006), Warner Music--Atlantic, Pre-Release CD image, 2006, 1 page.	X

DATE:	EXAMINER'S SIGNATURE:
-------	-----------------------

ALL REFERENCES CONSIDERED EXCEPT WHERE LINED THROUGH. //I.O./

Printed: March 20, 2015 (12:02pm)

Path: Y:\Clients\SCOT Scott A Moskowitz and Wistaria Trading,

Inc\SCOT0014-4\Drafts\ReferenceCitationList_SCOT0014-4_3-12-2015.wpd

37 CFR 1.98(a)(1)(i) APPLICATION & ATTORNEY DOCKET: 11/895,388 / SCOT0014-4

37 CFR 1.98(a)(1)(iii): THIS IS AN INFORMATION DISCLOSURE STATEMENT

EXAMINER INITIAL	REF. NO. (L series)	REFERENCE NUMBER (L Series)	PUB. DATE	INCLUDE IN SEQUENCE: Name of first author (in CAPITAL LETTERS), Title in quotation marks, name of publication, date or publication, page numbers, publisher, city of publication, and country of publication NOTE - For US patent applications listed herein, if a	REFERENCES CITED AND CONSIDERED BY EXAMINER IN PARENT CASE IDENTIFIED BY PLACEMENT OF "X"
	98	L- 098		DUPLICATE OF L-97, DELETED BY 11/16/2010 by RAN.	X
	99	L- 099	2003	Radiohead ("Hail To The Thief"), EMI Music Group--Capitol, Pre-Release CD image, 2003, 1 page.	X
	100	L- 0100	N/A	DUPLICATE OF L-4, DELETED BY RN UPON REVIEW ON 11/18/2010. RAN	X
	101	L- 0101	N/A	U.S. Appl. No. 60/169,274, filed Dec. 7, 1999, entitled "Systems, Methods And Devices For Trusted Transactions".	X
	102	L- 0102		DUPLICATE OF L-22, DELETED BY RN UPON REVIEW ON 11/16/2010. RAN	X
	103	L- 0103		DUPLICATE OF L-27, DELETED BY RN UPON REVIEW ON 11/16/2010. RAN	X
	104	L- 0104	N/A	U.S. Appl. No. 60/234,199, filed Sep. 20, 2000, "Improved Security Based on Subliminal and Supraliminal Channels For Data Objects".	X
	105	L- 0105	N/A	U.S. Appl. No. 09/671,739, filed Sep. 29, 2000, entitled "Method And Device For Monitoring And Analyzing Signals".	X
	106	L- 0106		DUPLICATE OF L-34, DELETED BY RN UPON REVIEW ON 11/16/2010. RAN	X
	107	L- 0107		DUPLICATE OF L-24, DELETED BY RN UPON REVIEW ON 11/16/2010. RAN	X
	108	L- 0108		DUPLICATE OF L-57, DELETED BY RN UPON REVIEW ON 11/16/2010. RAN	X
	109	L- 0109		DUPLICATE OF L-58, DELETED BY RN UPON REVIEW ON 11/16/2010. RAN	X
	110	L- 0110		DUPLICATE OF L-59, DELETED BY RN UPON REVIEW ON 11/16/2010. RAN	X
	111	L- 0111		DUPLICATE OF L-61, DELETED BY RN UPON REVIEW ON 11/16/2010. RAN	X

DATE:	EXAMINER'S SIGNATURE:
-------	-----------------------

ALL REFERENCES CONSIDERED EXCEPT WHERE LINED THROUGH. //I.O./

Printed: March 20, 2015 (12:02pm)

Path: Y:\Clients\SCOT Scott A Moskowitz and Wistaria Trading,

Inc\SCOT0014-4\Drafts\ReferenceCitationList_SCOT0014-4_3-12-2015.wpd

37 CFR 1.98(a)(1)(i) APPLICATION & ATTORNEY DOCKET: 11/895,388 / SCOT0014-4

37 CFR 1.98(a)(1)(iii): THIS IS AN INFORMATION DISCLOSURE STATEMENT

EXAMINER INITIAL	REF. NO. (L series)	REFERENCE NUMBER (L Series)	PUB. DATE	INCLUDE IN SEQUENCE: Name of first author (in CAPITAL LETTERS), Title in quotation marks, name of publication, date or publication, page numbers, publisher, city of publication, and country of publication NOTE - For US patent applications listed herein, if a	REFERENCES CITED AND CONSIDERED BY EXAMINER IN PARENT CASE IDENTIFIED BY PLACEMENT OF "X"
	112	L- 0112		DUPLICATE OF L-62, DELETED BY RN UPON REVIEW ON 11/16/2010. RAN	X
	113	L- 0113		DUPLICATE OF L-63, DELETED BY RN UPON REVIEW ON 11/16/2010. RAN	X
	114	L- 0114		DUPLICATE OF L-65, DELETED BY RN UPON REVIEW ON 11/16/2010. RAN	X
	115	L- 0115	Unknown	Tirkel, A.Z., "A Two-Dimensional Digital Watermark", Scientific Technology, 686, 14, date unknown. (citation revised upon review on 11/16/10 by RAN.)	X
	116	L- 0116		DUPLICATE OF L-65, DELETED BY RN UPON REVIEW ON 11/16/2010. RAN	X
	117	L- 0117		DUPLICATE OF L-68, DELETED BY RN UPON REVIEW ON 11/16/2010. RAN	X
	118	L- 0118		DUPLICATE OF L-69, DELETED BY RN UPON REVIEW ON 11/16/2010. RAN	X
	119	L- 0119		DUPLICATE OF L-70, DELETED BY RN UPON REVIEW ON 11/16/2010. RAN	X
	120	L- 0120		DUPLICATE OF L-71, DELETED BY RN UPON REVIEW ON 11/16/2010. RAN	X
	121	L- 0121		DUPLICATE OF L-72, DELETED BY RN UPON REVIEW ON 11/16/2010. RAN	X
	122	L- 0122		DUPLICATE OF L-73, DELETED BY RN UPON REVIEW ON 11/16/2010. RAN	X
	123	L- 0123		DUPLICATE OF L-74, DELETED BY RN UPON REVIEW ON 11/16/2010. RAN	X
	124	L- 0124		DUPLICATE OF L-75, DELETED BY RN UPON REVIEW ON 11/16/2010. RAN	X
	125	L- 0125		DUPLICATE OF L-076, REMOVED. RN. 11/16/2010	X
	126	L- 0126		DUPLICATE OF L-77, REMOVED. RN. 11/16/2010	X

DATE:	EXAMINER'S SIGNATURE:
-------	-----------------------

ALL REFERENCES CONSIDERED EXCEPT WHERE LINED THROUGH. //I.O./

Printed: March 20, 2015 (12:02pm)

Path: Y:\Clients\SCOT Scott A Moskowitz and Wistaria Trading,

Inc\SCOT0014-4\Drafts\ReferenceCitationList_SCOT0014-4_3-12-2015.wpd

37 CFR 1.98(a)(1)(i) APPLICATION & ATTORNEY DOCKET: 11/895,388 / SCOT0014-4

37 CFR 1.98(a)(1)(iii): THIS IS AN INFORMATION DISCLOSURE STATEMENT

EXAMINER INITIAL	REF. NO. (L series)	REFERENCE NUMBER (L Series)	PUB. DATE	INCLUDE IN SEQUENCE: Name of first author (in CAPITAL LETTERS), Title in quotation marks, name of publication, date or publication, page numbers, publisher, city of publication, and country of publication NOTE - For US patent applications listed herein, if a	REFERENCES CITED AND CONSIDERED BY EXAMINER IN PARENT CASE IDENTIFIED BY PLACEMENT OF "X"
	127	L- 0127		DUPLICATE OF L-78, REMOVED. RN. 11/16/2010	X
	128	L- 0128		DUPLICATE OF L-79, REMOVED. RN. 11/16/2010	X
	129	L- 0129		EP0581317A2, MOVED TO FOREIGN PATENT PUBS as F-028	X
	130	L- 0130		DUPLICATE OF L-52, REMOVED. RN. 11/16/2010	X
	131	L- 0131		DUPLICATE OF L-36, REMOVED. RN. 11/16/2010	X
	132	L- 0132		DUPLICATE OF L-38, REMOVED. RN. 11/16/2010.	X
	133	L- 0133		DUPLICATE OF L-37, REMOVED. RN. 11/16/2010	X
	134	L- 0134		DUPLICATE OF L-36, REMOVED. RN. 11/16/2010	X
	135	L- 0135		DUPLICATE OF L-37, REMOVED. RN. 11/16/2010	X
	136	L- 0136		DUPLICATE OF L-38, REMOVED. RN. 11/16/2010	X
	137	L- 0137		DUPLICATE OF L-39, REMOVED. RN. 11/16/2010	X
	138	L- 0138		DUPLICATE OF L-40, REMOVED. RN. 11/16/2010	X
	139	L- 0139		DUPLICATE OF L-41, REMOVED. RN. 11/16/2010	X
	140	L- 0140		DUPLICATE OF L-42, REMOVED. RN. 11/16/2010	X
	141	L- 0141		DUPLICATE OF L-43, REMOVED. RN. 11/16/2010	X
	142	L- 0142		DUPLICATE OF L-44, REMOVED. RN. 11/16/2010	X
	143	L- 0143		DUPLICATE OF L-45, REMOVED. RN. 11/16/2010.	X
	144	L- 0144		DUPLICATE OF L-46, REMOVED. RN. 11/16/2010.	X
	145	L- 0145		DUPLICATE OF L-47, REMOVED. RN. 11/16/2010	X
	146	L- 0146		DUPLICATE OF L-48, REMOVED. RN. 11/16/2010	X

DATE:	EXAMINER'S SIGNATURE:
-------	-----------------------

ALL REFERENCES CONSIDERED EXCEPT WHERE LINED THROUGH. //I.O./

Printed: March 20, 2015 (12:02pm)

Path: Y:\Clients\SCOT Scott A Moskowitz and Wistaria Trading,

Inc\SCOT0014-4\Drafts\ReferenceCitationList_SCOT0014-4_3-12-2015.wpd

37 CFR 1.98(a)(1)(i) APPLICATION & ATTORNEY DOCKET: 11/895,388 / SCOT0014-4

37 CFR 1.98(a)(1)(iii): THIS IS AN INFORMATION DISCLOSURE STATEMENT

EXAMINER INITIAL	REF. NO. (L series)	REFERENCE NUMBER (L Series)	PUB. DATE	INCLUDE IN SEQUENCE: Name of first author (in CAPITAL LETTERS), Title in quotation marks, name of publication, date or publication, page numbers, publisher, city of publication, and country of publication NOTE - For US patent applications listed herein, if a	REFERENCES CITED AND CONSIDERED BY EXAMINER IN PARENT CASE IDENTIFIED BY PLACEMENT OF "X"
	147	L- 0147		DUPLICATE OF L-49, REMOVED. RN. 11/16/2010	X
	148	L- 0148		DUPLICATE OF L-50, REMOVED. RN. 11/16/2010	X
	149	L- 0149		DUPLICATE OF L-51, REMOVED. RN. 11/16/2010	X
	150	L- 0150		DUPLICATE OF L-52, REMOVED. RN. 11/16/2010	X
	151	L- 0151		DUPLICATE OF L-63, REMOVED. RN. 11/16/2010	X
	152	L- 0152		DUPLICATE OF L-54, REMOVED. RN. 11/16/2010	X
	153	L- 0153		DUPLICATE OF L-55, REMOVED. RN. 11/16/2010.	X
	154	L- 0154		DUPLICATE OF L-80, REMOVED. RN. 11/16/2010.	X
	155	L- 0155	N/A	PCT International Search Report in PCT/US95/08159.	X
	156	L- 0156	N/A	PCT International Search Report in PCT/US96/10257.	X
	157	L- 0157	N/A	Supplementary European Search Report in EP 96919405.	X
	158	L- 0158	N/A	PCT International Search Report in PCT/US97/00651.	X
	159	L- 0159	N/A	PCT International Search Report in PCT/US97/00652	X
	160	L- 0160	N/A	PCT International Search Report in PCT/US97/11455.	X
	161	L- 0161		PCT International Search Report in PCT/US99/07262.	X
	162	L- 0162		PCT International Search Report in PCT/US00/06522	X
	163	L- 0163		Supplementary European Search Report in EP00919398	X
	164	L- 0164		PCT International Search Report in PCT/US00/18411.	X
	165	L- 0165		PCT International Search Report in PCT/US00/18411.	X
	166	L- 0166		PCT International Search Report in PCT/US00/33126	X
	167	L- 0167		PCT International Search Report in PCT/US00/21189	X
	168	L- 0168		Delaigle, J.-F., et al. "Digital Watermarking," Proceedings of the SPIE, vol. 2659, Feb 1, 1996, pp. 99-110.	X

DATE:	EXAMINER'S SIGNATURE:
-------	-----------------------

ALL REFERENCES CONSIDERED EXCEPT WHERE LINED THROUGH. //I.O./

Printed: March 20, 2015 (12:02pm)

Path: Y:\Clients\SCOT Scott A Moskowitz and Wistaria Trading,

Inc\SCOT0014-4\Drafts\ReferenceCitationList_SCOT0014-4_3-12-2015.wpd

37 CFR 1.98(a)(1)(i) APPLICATION & ATTORNEY DOCKET: 11/895,388 / SCOT0014-4

37 CFR 1.98(a)(1)(iii): THIS IS AN INFORMATION DISCLOSURE STATEMENT

EXAMINER INITIAL	REF. NO. (L series)	REFERENCE NUMBER (L Series)	PUB. DATE	INCLUDE IN SEQUENCE: Name of first author (in CAPITAL LETTERS), Title in quotation marks, name of publication, date or publication, page numbers, publisher, city of publication, and country of publication NOTE - For US patent applications listed herein, if a	REFERENCES CITED AND CONSIDERED BY EXAMINER IN PARENT CASE IDENTIFIED BY PLACEMENT OF "X"
	169	L- 0169	1996	Schneider, M., et al. "A Robust Content Based Digital Signature for Image Authentication," Proceedings of the International Conference on Image Processing (IC. Lausanne) Sep. 16-19, 1996, pp. 227-230, IEEE ISBN.	X
	170	L- 0170	1997	Cox, I. J., et al. "Secure Spread Spectrum Watermarking for Multimedia," IEEE Transactions on Image Processing, vol. 6 No. 12, Dec. 1, 1997, pp. 1673-1686.	X
	171	L- 0171	1998	Wong, Ping Wah. "A Public Key Watermark for Image Verification and Authentication," IEEE International Conference on Image Processing, vol. 1 Oct. 4-7, 1998, pp. 455-459.	X
	172	L- 0172	1998	Fabien A.P. Petitcolas, Ross J. Anderson and Markkus G. Kuhn, "Attacks on Copyright Marking Systems," LNCS, vol. 1525, Apr. 14-17, 1998, pp. 218-238 ISBN: 3-540-65386-4.	X
	173	L- 0173	1996	Ross Anderson, "Stretching the Limits of Steganography," LNCS, vol. 1174, May/Jun. 1996, 10 pages, ISBN: 3-540-61996-8.	X
	174	L- 0174	1997	Joseph J.K. O'Ruanaidh and Thierry Pun, "Rotation, Scale and Translation Invariant Digital Image Watermarking", pre-publication, Summer 1997 4 pages.	X
	175	L- 0175	1997	Joseph J.K. O'Ruanaidh and Thierry Pun, "Rotation, Scale and Translation Invariant Digital Image Watermarking", Submitted to Signal Processing Aug. 21, 1997, 19 pages.	X
	176	L- 0176	2008	OASIS (Dig Out Your Soul), Big Brother Recordings Ltd, Promotional CD image, 2008, 1 page.	X
	177	L- 0177	1998	Rivest, R. "Chaffing and Winnowing: Confidentiality without Encryption", MIT Lab for Computer Science, http://people.csail.mit.edu/rivest/Chaffing.txt Apr. 24, 1998, 9 pp.	X
	178	L- 0178	2003	PortalPlayer, PP5002 digital media management system-on-chip, May 1, 2003, 4 pp.	X

DATE:	EXAMINER'S SIGNATURE:
-------	-----------------------

ALL REFERENCES CONSIDERED EXCEPT WHERE LINED THROUGH. //I.O./

Printed: March 20, 2015 (12:02pm)

Path: Y:\Clients\SCOT Scott A Moskowitz and Wistaria Trading,

Inc\SCOT0014-4\Drafts\ReferenceCitationList_SCOT0014-4_3-12-2015.wpd

37 CFR 1.98(a)(1)(i) APPLICATION & ATTORNEY DOCKET: 11/895,388 / SCOT0014-4

37 CFR 1.98(a)(1)(iii): THIS IS AN INFORMATION DISCLOSURE STATEMENT

EXAMINER INITIAL	REF. NO. (L series)	REFERENCE NUMBER (L Series)	PUB. DATE	INCLUDE IN SEQUENCE: Name of first author (in CAPITAL LETTERS), Title in quotation marks, name of publication, date or publication, page numbers, publisher, city of publication, and country of publication NOTE - For US patent applications listed herein, if a	REFERENCES CITED AND CONSIDERED BY EXAMINER IN PARENT CASE IDENTIFIED BY PLACEMENT OF "X"
	179	L- 0179	2001	VeriDisc, "The Search for a Rational Solution to Digital Rights Management (DRM)", http://64.244.235.240/news/whitepaper./docs/veridisc.sub.--white.sub.--paper.pdf , 2001, 15 pp.	X
	180	L- 0180	2008	Cayre, et al., "Kerckhoff's-Based Embedding Security Classes for WOA Data Hiding", IEEE Transactions on Information Forensics and Security, vol. 3 No. 1, Mar. 2008, 15 pp.	X
	181	L- 0181	1999	Wayback Machine, dated Jan. 17, 1999, http://web.archive.org/web/19990117020420/http://www.netzero.com/ , accessed on Feb. 19, 2008.	X
	182	L- 0182	1997	Namgoong, H., "An Integrated Approach to Legacy Data for Multimedia Applications", Proceedings of the 23rd EUROMICRO Conference, vol., Issue 1-4, Sep. 1997, pp. 387-391.	X
	183	L- 0183	2007	Wayback Machine, dated Aug. 26, 2007, http://web.archive.org/web/20070826151732/http://www.screenplaysmag.com/t-abid/96/articleType/ArticleView/articleId/495/Default.aspx/ .	X
	184	L- 0184	2009	"YouTube Copyright Policy: Video Identification tool--YouTube Help", accessed Jun. 4, 2009, http://www.google.com/support/youtube/bin/answer.py?hl=en&answer=83766 , 3 pp.	X
	185	L- 0185	N/A	U.S. Appl. No. 12/665,002, filed Dec. 22, 2009, entitled "Method for Combining Transfer Function with Predetermined Key Creation", published as 20100182570 A1 07-22-2010, P76.	X
	186	L- 0186	N/A	U.S. Appl. No. 12/592,331, filed Nov. 23, 2009, entitled "Optimization Methods for the Insertion, Protection, and Detection of Digital Watermarks in Digital Data", published as 20100077220 A1 03-25-2010, P77.	X
	187	L- 0187	N/A	U.S. Appl. No. 12/590,553, filed Nov. 10, 2009, entitled "Optimization Methods for the Insertion, Protection, and Detection of Digital Watermarks in Digital Data", published as 20100077219 A1 03-25-2010, P78.	X

DATE:	EXAMINER'S SIGNATURE:
-------	-----------------------

ALL REFERENCES CONSIDERED EXCEPT WHERE LINED THROUGH. //I.O./

Printed: March 20, 2015 (12:02pm)

Path: Y:\Clients\SCOT Scott A Moskowitz and Wistaria Trading,

Inc\SCOT0014-4\Drafts\ReferenceCitationList_SCOT0014-4_3-12-2015.wpd

37 CFR 1.98(a)(1)(i) APPLICATION & ATTORNEY DOCKET: 11/895,388 / SCOT0014-4

37 CFR 1.98(a)(1)(iii): THIS IS AN INFORMATION DISCLOSURE STATEMENT

EXAMINER INITIAL	REF. NO. (L series)	REFERENCE NUMBER (L Series)	PUB. DATE	INCLUDE IN SEQUENCE: Name of first author (in CAPITAL LETTERS), Title in quotation marks, name of publication, date or publication, page numbers, publisher, city of publication, and country of publication NOTE - For US patent applications listed herein, if a	REFERENCES CITED AND CONSIDERED BY EXAMINER IN PARENT CASE IDENTIFIED BY PLACEMENT OF "X"
	188	L- 0188	N/A	U.S. Appl. No. 12/590,681, filed Nov. 12, 2009, entitled "Optimization Methods for the Insertion, Protection, and Detection of Digital Watermarks in Digital Data", published as 20100064140 A1 03-11-2010, P79.	X
	189	L- 0189	N/A	U.S. Appl. No. 12/655,036, filed Dec. 22, 2009, entitled "Utilizing Data Reduction in Steganographic and Cryptographic Systems", published as 20100153734 A1 06-17-2010, P80 .	X
	190	L- 0190	N/A	U.S. Appl. No. 12/655,357, filed Dec. 22, 2009, entitled "Method And Device For Monitoring And Analyzing Signals", published as 20100106736 A1 04-29-2010, P81.	X
	191	L- 0191	N/A	PCT Application No. PCT/US95/08159, filed Jun. 26, 1995, entitled, "Digital Information Commodities Exchange with Virtual Menuing", published as WO/1997/001892; Publication Date: 16.01.1997, F24.	X
	192	L- 0192	N/A	PCT Application No. PCT/US96/10257, filed Jun. 7, 1996, entitled "Steganographic Method and Device"--corresponding to--EPO Application No. 96919405.9, entitled "Steganographic Method and Device", published as WO/1996/042151; Publication Date: 27.12.1996; F19.	X
	193	L- 0193	N/A	PCT Application No. PCT/US97/00651, filed Jan. 16, 1997, entitled, "Method for Stega-Cipher Protection of Computer Code", published as WO/1997/026732; Publication Date: 24.07.1997.	X
	194	L- 0194	N/A	PCT Application No. PCT/US97/00652, filed Jan. 17, 1997, entitled, "Method for an Encrypted Digital Watermark", published as WO/1997/026733; Publication Date: 24.07.1997	X
	195	L- 0195	N/A	PCT Application No. PCT/US97/11455, filed Jul. 2, 1997, entitled, "Optimization Methods for the Insertion, Protection and Detection of Digital Watermarks in Digitized Data", published as WO/1998/002864; Publication Date: 22.01.1998	X

DATE:	EXAMINER'S SIGNATURE:
-------	-----------------------

ALL REFERENCES CONSIDERED EXCEPT WHERE LINED THROUGH. //I.O./

Printed: March 20, 2015 (12:02pm)

Path: Y:\Clients\SCOT Scott A Moskowitz and Wistaria Trading,

Inc\SCOT0014-4\Drafts\ReferenceCitationList_SCOT0014-4_3-12-2015.wpd

37 CFR 1.98(a)(1)(i) APPLICATION & ATTORNEY DOCKET: 11/895,388 / SCOT0014-4

37 CFR 1.98(a)(1)(iii): THIS IS AN INFORMATION DISCLOSURE STATEMENT

EXAMINER INITIAL	REF. NO. (L series)	REFERENCE NUMBER (L Series)	PUB. DATE	INCLUDE IN SEQUENCE: Name of first author (in CAPITAL LETTERS), Title in quotation marks, name of publication, date or publication, page numbers, publisher, city of publication, and country of publication NOTE - For US patent applications listed herein, if a	REFERENCES CITED AND CONSIDERED BY EXAMINER IN PARENT CASE IDENTIFIED BY PLACEMENT OF "X"
	196	L- 0196	N/A	PCT Application No. PCT/US99/07262, filed Apr. 2, 1999, entitled, "Multiple Transform Utilization and Applications for Secure Digital Watermarking", published as WO/1999/052271; Publication Date: 14.10.1999.	X
	197	L- 0197	N/A	PCT Application No. PCT/US00/06522, filed Mar. 14, 2000, entitled, "Utilizing Data Reduction in Steganographic and Cryptographic Systems", published as WO/2000/057643; Publication Date: 28.09.2000.	X
	198	L- 0198	N/A	PCT Application No. PCT/US00/18411, filed Jul. 5, 2000, entitled, "Copy Protection of Digital Data Combining Steganographic and Cryptographic Techniques"	X
	199	L- 0199	N/A	PCT Application No. PCT/US00/33126, filed Dec. 7, 2000, entitled "Systems, Methods and Devices for Trusted Transactions", published as WO/2001/043026; Publication Date: 14.06.2001.	X
	200	L- 0200	N/A	EPO Divisional Patent Application No. 07112420.0, entitled "Steganographic Method and Device" corresponding to PCT Application No. PCT/US96/10257, published as WO/1996/042151, 12/27/1996, cited herein above as F019.	X
	201	L- 0201	N/A	US Provisional Application 60/222,023 filed July 31, 2007 entitled "Method and apparatus for recognizing sound and signals in high noise and distortion"	X
	202	L- 0202	N/A	US Application 11/458,639 filed July 19, 2006 entitled "Methods and Systems for Inserting Watermarks in Digital Signals", published as 20060251291 A1 11-09-2006, P82.	X
	203	L- 0203	1995	"Techniques for Data Hiding in Audio Files," by Morimoto, 1995	X
	204	L- 0204	1998	Howe, Dennis July 13, 1998 http://foi.doc.org/steganography	X
	205	L- 0205	N/A	CSG, Computer Support Group and CSGNetwork.com 1973 http://www.csghnetwork.com/glossarys.html	X

DATE:	EXAMINER'S SIGNATURE:
-------	-----------------------

ALL REFERENCES CONSIDERED EXCEPT WHERE LINED THROUGH. //I.O./

Printed: March 20, 2015 (12:02pm)

Path: Y:\Clients\SCOT Scott A Moskowitz and Wistaria Trading,

Inc\SCOT0014-4\Drafts\ReferenceCitationList_SCOT0014-4_3-12-2015.wpd

37 CFR 1.98(a)(1)(i) APPLICATION & ATTORNEY DOCKET: 11/895,388 / SCOT0014-4

37 CFR 1.98(a)(1)(iii): THIS IS AN INFORMATION DISCLOSURE STATEMENT

EXAMINER INITIAL	REF. NO. (L series)	REFERENCE NUMBER (L Series)	PUB. DATE	INCLUDE IN SEQUENCE: Name of first author (in CAPITAL LETTERS), Title in quotation marks, name of publication, date or publication, page numbers, publisher, city of publication, and country of publication NOTE - For US patent applications listed herein, if a	REFERENCES CITED AND CONSIDERED BY EXAMINER IN PARENT CASE IDENTIFIED BY PLACEMENT OF "X"
	206	L- 0206	2010	QuinStreet Inc. 2010 What is steganography?-A word definition from the Webopedia Computer Dictionary http://www.webopedia.com/terms/steganography.html	X
	207	L- 0207	2000	Graham, Robert August 21, 2000 "Hacking Lexicon" http://robertgraham.com/pubs/hacking-dict.html	X
	208	L- 0208	2010	Farkex, Inc 2010 "Steganography definition of steganography in the Free Online Encyclopedia" http://encyclopedia2.thefreedictionary.com/steganography	X
	209	L- 0209	1989	Horowitz, et al., The Art of Eletronics. 2 nd Ed., 1989, pp7	X
	210	L- 0210	2004	Jimmy eat world ("futures"), Interscope Records, Pre-Release CD image, 2004, 1 page.	X
	211	L- 0211	2001	Aerosmith ("Just Push Play"), Pre-Release CD image, 2001, 1 page.	X
	212	L- 0212	2002	Phil Collins(Testify) Atlantic, Pre-Release CD image, 2002, 1 page.	X
	213	L- 0213	1998	U. are U. Reviewer's Guide (U are U Software, 1998)	
	214	L- 0214	1998	U. are U. wins top honors! - Marketing Flyer (U. are U. Software, 1998).	
	215	L- 0215	1998	Digital Persona, Inc., <u>U. are U. Fingerprint Recognition System: User Guide</u> (Version 1.0, 1998).	
	216	L- 0216	1998	Digital Persona White Paper pp 8-9 published April 15, 1998.	
	217	L- 0217	2000	Digital Persona, Inc., "Digital Persona Releases U. are. U Pro Fingerprint Security Systems for Windows NT, 2000, '98, '95", (2000, February)	
	218	L- 0218	2011	SonicWall, Inc. 2011 "The Network Security SonicOS Platform-Deep Packet Inspection" http://www.sonicwall.com/us/en/products/Deep_Packet_Inspction.html	

DATE:	EXAMINER'S SIGNATURE:
-------	-----------------------

ALL REFERENCES CONSIDERED EXCEPT WHERE LINED THROUGH. //I.O./

Printed: March 20, 2015 (12:02pm)

Path: Y:\Clients\SCOT Scott A Moskowitz and Wistaria Trading,

Inc\SCOT0014-4\Drafts\ReferenceCitationList_SCOT0014-4_3-12-2015.wpd

37 CFR 1.98(a)(1)(i) APPLICATION & ATTORNEY DOCKET: 11/895,388 / SCOT0014-4

37 CFR 1.98(a)(1)(iii): THIS IS AN INFORMATION DISCLOSURE STATEMENT

EXAMINER INITIAL	REF. NO. (L series)	REFERENCE NUMBER (L Series)	PUB. DATE	INCLUDE IN SEQUENCE: Name of first author (in CAPITAL LETTERS), Title in quotation marks, name of publication, date or publication, page numbers, publisher, city of publication, and country of publication NOTE - For US patent applications listed herein, if a	REFERENCES CITED AND CONSIDERED BY EXAMINER IN PARENT CASE IDENTIFIED BY PLACEMENT OF "X"
	219	L- 0219	2011	Rick Merritt, PARC hosts summit on content-centric nets, EETimes, Aug. 12, 2011, http://www.eetimes.com/electronics-news/4218741/PARC-hosts-summit-on-content-centric-nets	
	220	L- 0220	2011	Afanasyev, et. al., Communications of the ACM: Privacy Preserving Network Forensics 2011	
	221	L- 0221	2008	SonicWall, Inc., 2008 "The Advantages of a Multi-core Architecture In Network Security Appliances" http://www.sonicwall.com/downloads/WP-ENG-010_Multicore...	
	222	L- 0222	2013	Voip-Pal.Com Inc's Lawful Intercept Patent Application Receives the Allowance for Issuance as a Patent, http://finance.yahoo.com/news/voip-pal-com-inc-lawful-133000133.html	
	223	L- 0223	2013	Deep Content Inspection - Wikipedia, the free encyclopedia, http://en.wikipedia.org/wiki/Deep_content_inspection (last visited Apr. 4, 2013)	
	224	L- 0224	2009	Dexter, et. al, "Multi-view Synchronization of Human Actions and Dynamic Scenes" pp 1-11, 2009	
	225	L- 0225	2011	Kudrle, et al., "Fingerprinting for Solving A/V Synchronization Issues within Broadcast Environments", 2011	
	226	L- 0226	2010	Junego, et. al., "View-Independent Action Recognition from Temporal Self-Similarities", 2011	
	227	L- 0227	2009	Dexter, et al., "Multi-view Synchronization Of Image Sequences", 2009	
	228	L- 0228	2013	Blue Spike, LLC. v. Texas Instruments, Inc et. al, (No: 6:12-CV-499-MHS), Audible Magic Corporations's amended Answer (E.D. TX filed 7/15/2013) (Document 885 page ID 9581), (PACER)	
	229	L- 0229	2006	Moskowitz, "Introduction-Digital Rights Management," Multimedia Security Technologies for Digital Rights Management (2006), Elsevier	

DATE:	EXAMINER'S SIGNATURE:
-------	-----------------------

ALL REFERENCES CONSIDERED EXCEPT WHERE LINED THROUGH. //I.O./

Printed: March 20, 2015 (12:02pm)

Path: Y:\Clients\SCOT Scott A Moskowitz and Wistaria Trading,

Inc\SCOT0014-4\Drafts\ReferenceCitationList_SCOT0014-4_3-12-2015.wpd

37 CFR 1.98(a)(1)(i) APPLICATION & ATTORNEY DOCKET: 11/895,388 / SCOT0014-4

37 CFR 1.98(a)(1)(iii): THIS IS AN INFORMATION DISCLOSURE STATEMENT

EXAMINER INITIAL	REF. NO. (L series)	REFERENCE NUMBER (L Series)	PUB. DATE	INCLUDE IN SEQUENCE: Name of first author (in CAPITAL LETTERS), Title in quotation marks, name of publication, date or publication, page numbers, publisher, city of publication, and country of publication NOTE - For US patent applications listed herein, if a	REFERENCES CITED AND CONSIDERED BY EXAMINER IN PARENT CASE IDENTIFIED BY PLACEMENT OF "X"
	230	L- 0230	1999	George, Mercy; Chouinard, Jean-Yves; Georgana, Nicolas. Digital Watermarking of Images and video using Direct Sequence Spread Spectrum Techniques. 1999 IEEE Canadian Conference on Electrical and Computer Engineering Vol. 1. Pub. Date: 1999 Relevant pages 116-121. http://ieeexplore.ieee.org/stamp/stamp.jsp?tp=arnumber=807181	
	231	L- 0231	4/4/2014	Shazam Entertainment Limited's Amended Answer to Blue Spike, LLC's complaint and counterclaims against Blue Spike LLC, Blue Spike, Inc and Scott A. Moskowitz , Shazam Entertainment Ltd v. Blue Spike, LLC, Blue Spike, Inc, and Scott Moskowitz (E.D.T.X Dist Ct.) Case No. 6:12-CV-00499-MHS	
	232	L- 0232	4/4/2014	Audible Magic Corporation's Second Amended Answer to Blue Spike LLC's Original Complaint for patent infringement and counterclaims against Blue Spike LLC, Blue Spike, Inc and Scott Moskowitz. Blue Spike LLC v. Texas Instruments, Audible Magic Corporation (E.D.T.X Dist Ct.) Case No. 6:12-CV-499-MHS	
	233	L- 0233	12/19/2011	Shrivastava, et.al. , "Data-Driven Visual Similarity for Cross-Domain Image Matching", 2011 ACM Transaction of Graphics (TOG), ACM SIGGRAPH Asia vol. 30 number 6, http://graphics.cs.cmu.edu/projects/crossDomainMatching/	
	234	L- 0234	12/6/2011	Spice, Byron, "Carnegie Mellon Researchers Develop Computerized Method for Finding Similar Images in Photos, Paintings, Sketches", Carnegie Mellon News, Dec 6, 2011, Carnegie Mellon University. http://www.cmu.edu/news/stories/archives/2011/december/dec6_matchingimages.html	
	235	L- 0235	10/16/2014	Memorandum Opinion and Order, Blue Spike LLC v. Texas Instruments, Inc. et al., (E.D.T.X Dist Ct), Case No. 6:12-CV-0499-MHS-CMC (Doc#1831 PageID#27507)	

DATE:	EXAMINER'S SIGNATURE:
-------	-----------------------

ALL REFERENCES CONSIDERED EXCEPT WHERE LINED THROUGH. //I.O./

Printed: March 20, 2015 (12:02pm)

Path: Y:\Clients\SCOT Scott A Moskowitz and Wistaria Trading,

Inc\SCOT0014-4\Drafts\ReferenceCitationList_SCOT0014-4_3-12-2015.wpd

37 CFR 1.98(a)(1)(i) APPLICATION & ATTORNEY DOCKET: 11/895,388 / SCOT0014-4

37 CFR 1.98(a)(1)(iii): THIS IS AN INFORMATION DISCLOSURE STATEMENT

EXAMINER INITIAL	REF. NO. (L series)	REFERENCE NUMBER (L Series)	PUB. DATE	INCLUDE IN SEQUENCE: Name of first author (in CAPITAL LETTERS), Title in quotation marks, name of publication, date or publication, page numbers, publisher, city of publication, and country of publication NOTE - For US patent applications listed herein, if a	REFERENCES CITED AND CONSIDERED BY EXAMINER IN PARENT CASE IDENTIFIED BY PLACEMENT OF "X"
	236	L- 0236	10/16/2014	Memorandum Opinion and Order, Blue Spike LLC v. Texas Instruments, Inc. et al., (E.D.T.X Dist Ct), Case No. 6:12-CV-0499-MHS-CMC (Doc#1834 PageID#27597)	
	237	L- 0237	1989	Yu, Che-Fn, "Access Control and Authorization Plan for Customer Control of Network Services", IEEE GLOBECOM 1989 Pub 1989. pgs 862-869. http://ieeexplore.ieee.org/stamp/stamp.jsp?tp=&arnumber=64085	
	238	L- 0238	1996	Jaeger, Trent; Prakash, Atul; Rubin, Aviel D, "A System Architecture for Flexible Control of Downloaded Executable Content." Proceedings of the Fifth International Workshop on Object-Oriented in Operating Systems. Pub 1996, pgs 14-18. http://ieeexplore.ieee.org/stamp/stamp.jsp?tp=&arnumber=557855	
	239	L- 0239	5/2011	"Activate Your Product Through The Online License Management System (LMS)", May 2011 Juniper Networks, Inc., USA	
	240	L- 0240	5/2011	"Activate Your Software Capacity and/or Features", May 2011, Juniper Networks, USA	
	241	L- 0241	5/2011	"Download and Activate Your Software", May 2011, Juniper Networks, Inc., USA	
	242	L- 0242	9/2009	"Electronic Fulfillment of Feature, Capacity and Subscription License Activation Keys via the License Management System (LMS)", September 2009, Juniper Networks, Inc., USA	

DATE:	EXAMINER'S SIGNATURE:
-------	-----------------------

ALL REFERENCES CONSIDERED EXCEPT WHERE LINED THROUGH. //I.O./

Printed: March 20, 2015 (12:02pm)

Path: Y:\Clients\SCOT Scott A Moskowitz and Wistaria Trading,

Inc\SCOT0014-4\Drafts\ReferenceCitationList_SCOT0014-4_3-12-2015.wpd

37 CFR 1.98(a)(1)(i) APPLICATION & ATTORNEY DOCKET: 11/895,388 / SCOT0014-4

37 CFR 1.98(a)(1)(iii): THIS IS AN INFORMATION DISCLOSURE STATEMENT

EXAMINER INITIAL	REF. NO. (L series)	REFERENCE NUMBER (L Series)	PUB. DATE	INCLUDE IN SEQUENCE: Name of first author (in CAPITAL LETTERS), Title in quotation marks, name of publication, date or publication, page numbers, publisher, city of publication, and country of publication NOTE - For US patent applications listed herein, if a	REFERENCES CITED AND CONSIDERED BY EXAMINER IN PARENT CASE IDENTIFIED BY PLACEMENT OF "X"
	243	L- 0243	7/2009	"Juniper Networks License Management System (LMS) FAQ", July 2009, Juniper Networks, Inc., USA	
	244	L- 0244	12/2014	"License Activation Keys", Dec14, 2014, http://www.juniper.net/generate_license/	
	245	L- 0245	3/2014	"License code and configuration key reference [AX 2012]", Mar 25, 2014, Microsoft http://technet.microsoft.com/en-us/library/hh378074.aspx	
	246	L- 0246	12/2014	"License Codes", Dec 14, 2014, Oracle http://www.oracle.com/us/support/licensecodes/index.html	
	247	L- 0247	12/2014	"PeopleSoft Enterprise: License Codes", Dec 14, 2014, http://www.oracle.com/us/support/licensecodes/peoplesoft-enterprise/index.html	
	248	L- 0248	12/2014	"Primavera License Key Files", Dec 14, 2014, http://www.oracle.com/us/support/licensecodes/primavera/index.html	
	249	L- 0249	12/2014	"Siebel License Keys", Dec 14, 2014, http://www.oracle.com/us/support/licensecodes/siebel/index.html	
	250	L- 0250	03/2009	"How to transfer a license activation key to an RMA replacement device", March 2009, Juniper Networks, Inc. USA	

DATE:	EXAMINER'S SIGNATURE:
-------	-----------------------

ALL REFERENCES CONSIDERED EXCEPT WHERE LINED THROUGH. //I.O./

Printed: March 20, 2015 (12:02pm)

Path: Y:\Clients\SCOT Scott A Moskowitz and Wistaria Trading,

Inc\SCOT0014-4\Drafts\ReferenceCitationList_SCOT0014-4_3-12-2015.wpd

37 CFR 1.98(a)(1)(i) APPLICATION & ATTORNEY DOCKET: 11/895,388 / SCOT0014-4

37 CFR 1.98(a)(1)(iii): THIS IS AN INFORMATION DISCLOSURE STATEMENT

EXAMINER INITIAL	REF. NO. (L series)	REFERENCE NUMBER (L Series)	PUB. DATE	INCLUDE IN SEQUENCE: Name of first author (in CAPITAL LETTERS), Title in quotation marks, name of publication, date or publication, page numbers, publisher, city of publication, and country of publication NOTE - For US patent applications listed herein, if a	REFERENCES CITED AND CONSIDERED BY EXAMINER IN PARENT CASE IDENTIFIED BY PLACEMENT OF "X"
	251	L- 0251	12/2014	"How to register a license key in My VMware (2011177)", Dec 14, 2014, http://kb.vmware.com/selfservice/microsites/search.do?cmd=displayKC&docType=ex&bbid=TSEBB_1334428459608&url=&stateId=1%200%20462914399&dialogID=462898852&docTypeID=DT_KB_1_1&externalId=2011177&sliceId=1&rflid=	
	252	L- 0252	7/2001	CHAUSSEE, "Inside Windows Product Activation", July 2001, http://www.licenturion.com/xp	
	253	L- 0253	12/2014	"How to generate and validate a software key license", Dec 14, 2014, Stack Overflow, http://stackoverflow.com/questions/599837/how-to-generate-and-validate-a-software-license-key	
	254	L- 0254	7/2005	DONSW, "License Key Generation", Jul 2005, Code Project, http://www.codeproject.com/articles/11012/License-Key-Generation	
	255	L- 0255	12/2004	"How are Software License Keys generated?", Dec 14, 2014, Stack Overflow, http://stackoverflow.com/questions/3002067/how-are-software-license-keys-generated	
	256	L- 0256	3/2015	Decision on Appeal, USPTO PTAB Appeal No. 2012-011854 for application 11/895,388 issued March 12, 2015.	

DATE: /tuzna Okeke/	EXAMINER'S SIGNATURE: 05/31/2015
---------------------	----------------------------------

ALL REFERENCES CONSIDERED EXCEPT WHERE LINED THROUGH. //I.O./

NEIFELD REF: SCOT0014-4
 CLIENT REF: SCOT0014-4
 Application/Patent No: 11/895,388
 USPTO CONF. NO: 2103
 Inventor: MOSKOWITZ, Scott
 Title: DATA PROTECTION METHOD AND DEVICE
 Examiner/ArtUnit: OKEKE, Izunna/2432
 ENTITY STATUS: SMALL
 Priority claims and PCT Intl data:
 Application 11/895,388 is a Division of 10/602,777 filed 6-25-2003 patented 7,664,263
 Application 10/602,77 is a Continuation of 09/046,627 filed 3-24-1998 patented 6,598,162
 Application 09/046,627 is a Continuation in Part of 08/587,943 filed 1-17-1996 patented 5,745,569

37 CFR 1.97 INFORMATION DISCLOSURE STATEMENT

This application is:
 ___ within 3 months of the US or 371 national stage filing date;
 ___ before first action on the merits (no fee required);
XXX after first action on the merits and before final action (1.17(P) fee required);
 ___ after final action;
 ___ after notice of allowance and before payment of the issue fee; or
 ___ after payment of the issue fee.

XXX The applicant is paying herewith the fee for obtaining consideration of an IDS filed after a first action on the merits.

IDENTIFICATION OF REFERENCES CITED IN APPLICATIONS TO WHICH 11/895,388 CLAIMS CONTINUING STATUS

REGARDING CITED REFERENCES

This IDS is an attempt to compile all references previously cited in Scott Moskowitz's cases. Upon compilation, some of the reference citations were vague, and some were to filed patent applications instead of published documents. This IDS attempts to account for each item to provide all citations to the examiner.

References previously cited and considered by the examiner in application 11/895,388(SCOT0014-4) are identified by placement of an "X" in the far right column.

CITED US PATENTS AND US PATENT APPLICATION PUBLICATIONS

Most pending Scott Moskowitz cases claim 35 USC 120 priority to prior cases containing a large number of cited US patents and published US applications. The citations list herein should incorporate all of those documents and may incorporate any additional documents found in other patent applications in patent families not linked by 35 USC 120 to this application. Since no US patent or US published applications need to be filed in order for the examiner to

ALL REFERENCES CONSIDERED EXCEPT WHERE LINED THROUGH. //I.O./

consider citations thereto; the applicant may attempt to correlate the US patents and publications cited herein to those already of record due to citations in applications to which this application claims priority, if the examiner so requests.

FOREIGN PATENT REFERENCES

The IDS cites foreign patent references identified herewith as F001- F029 .

The table below identifies F references cited in this application or an application to which this application claims 35 USC 120 priority.

DOCKET NO	APPLICATION NUMBER	CITED F REFERENCES
SCOT0014-4	11/895,388	F01-F029

Accordingly, the following F references are not yet of record and are submitted herewith: n/a

NON PATENT LITERATURE REFERENCES

The IDS cites foreign patent references identified herewith as L001- L256.

The table below identifies L references cited in this application or in an application to which this application claims 35 USC 120 priority.

DOCKET NO	APPLICATION NUMBER	CITED L REFERENCES
SCOT0014-4	11/895,388	L1-L212
	L reference citations of patent applications as filed for which a subsequent publication of the application is identified and cited herein.	L01-L35; L185-L200; L202
	L reference citation numbers that have no associated citation; original citation was a duplicate of some other citation.	L98, L100, L102; L103; L106-L114; L116-L154

References previously cited, applications for which a subsequent publication is cited, and reference numbers having no associated reference: L1-L212

Accordingly, the following L references are not yet of record and are submitted herewith: L213-L256

MASTER LIST OF RELATED CASES IN WHICH THE SAME INFORMATION MAY BE CITED

DOCKET REFERENCE	APPLICATION	FILING DATE	DATE CASE ADDED TO THIS MASTER LIST OF RELATED CASES
SCOT0010-4	11/599,838	11/15/2006	10/15/2010 JRE
SCOT0010-5	11/899,662	9/7/2007	10/15/2010 JRE
SCOT0010-6	10/369,344	2/18/2003	08/1/2011 JRE
SCOT0010-7	11/482,654	7/7/2006	08/1/2011 JRE
SCOT0010-8	12/215,812	6/30/2008	10/15/2010 JRE
SCOT0010-10	12/901,568	10/10/2010	11/4/2010 JRE
SCOT0010-11	11/497,822	8/2/2006	08/1/2011 JRE
SCOT0010-12	12/217,834	7/9/2008	11/8/2010 JRE
SCOT0010-13	11/897,790	8/31/2007	08/1/2011 JRE
SCOT0010-14	12/462,799	8/10/2009	12/15/2010 JRE
SCOT0010-16	11/899,661	9/7/2007	08/1/2011 JRE
SCOT0010-17	12/590,681	11/19/2009	12/15/2010 JRE
SCOT0010-18	11/897,791	8/31/2007	08/1/2011 JRE
SCOT0010-19	12/590,553	11/10/2009	08/1/2011 JRE
SCOT0010-20	12/592,331	11/23/2009	08/1/2011 JRE
SCOT0010-21	11/599,964	11/15/2006	08/1/2011 JRE
SCOT0010-22	13/212,264	8/18/2011	1/11/2012 JRE
SCOT0011-1	08/674,726	7/2/1996	08/1/2011 JRE
SCOT0011-2	09/545,589	4/7/2000	1/11/2012 JRE
SCOT0011-3	11/244,213	10/5/2005	1/11/2012 JRE
SCOT0011-4	12/009,914	1/23/2008	10/15/2010 JRE
SCOT0011-5	12/005,230	12/26/2007	10/15/2010 JRE
SCOT0011-6	12/803,168	6/21/2010	10/15/2010 JRE
SCOT0011-7	11/649,026	1/3/2007	08/1/2011 JRE
SCOT0011-8	12/803,194	06/21/2010	10/15/2010 JRE
SCOT0011-9	12/892,900	9/28/2010	11/8/2010 JRE

ALL REFERENCES CONSIDERED EXCEPT WHERE LINED THROUGH. //I.O./

DOCKET REFERENCE	APPLICATION	FILING DATE	DATE CASE ADDED TO THIS MASTER LIST OF RELATED CASES
SCOT0012-1	08/489,172	6/7/1995	08/1/2011 JRE
SCOT0012-2	08/775,216	12/31/1996	01/11/2011 JRE
SCOT0012-3	08/999,766	7/23/1997	10/15/2010 JRE
SCOT0012-4	11/894,476	8/21/2007	10/15/2010 JRE
SCOT0012-5	11/050,779	2/7/2005	10/15/2010 JRE
SCOT0012-6	12/802,519	6/8/2010	11/4/2010 JRE
SCOT0012-7	12/383,916	3/30/2009	10/15/2010 JRE
SCOT0012-8	11/894,443	8/21/2007	10/15/2010 JRE
SCOT0012-9	12/913,751	10/27/2010	11/8/2010 JRE
SCOT0012-10	13/803,889	3/14/2013	4/16/2013 JRE
SCOT0013-1	08/587,943	1/17/1996	1/11/2012 JRE
SCOT0014-1	09/046,627	3/24/1998	1/11/2012 JRE
SCOT0014-2	10/602,777	6/25/2003	08/1/2011 JRE
SCOT0014-3 redocketed as SCOT0020-2	11/512,701	8/29/2006	10/15/2010 JRE
SCOT0014-4	11/895,388	8/24/2007	10/15/2010 JRE
SCOT0014-5	12/655,002	12/22/2009	08/1/2011 JRE
SCOT0014-6	13/556,420	7/24/2012	9/17/2012 JRE
SCOT0014-7	13/794,584	3/12/2013	4/16/2013 JRE
SCOT0015-1	09/731,039	12/7/2000	1/11/2012 JRE
SCOT0015-2	11/647/861	12/29/2006	1/11/2012 JRE
SCOT0015-3	12/383,879	3/30/2009	10/15/2010 JRE
SCOT0015-4	12/886,732	9/21/2010	10/15/2010 JRE
SCOT0015-5	13/572,641	8/11/2012	10/11/2012 JRE
SCOT0015-6	13/794,742	3/12/2013	4/16/2013 JRE
SCOT0016-1	10/049,101	7/23/2002	1/11/2012 JRE
SCOT0016-2	12/287,443	10/9/2008	10/15/2010 JRE
SCOT0016-3	13/413,691	3/7/2012	8/30/2012 JRE
SCOT0016-4	13/796,538	3/12/2013	4/16/2013 JRE
SCOT0017-1	09.657,181	9/7/2000	1/11/2012 JRE

ALL REFERENCES CONSIDERED EXCEPT WHERE LINED THROUGH. //I.O./

DOCKET REFERENCE	APPLICATION	FILING DATE	DATE CASE ADDED TO THIS MASTER LIST OF RELATED CASES
SCOT0017-2	12/005,229	12/26/2007	1/11/2012 JRE
SCOT0017-3	12/655,357	12/22/2009	10/15/2010 JRE
SCOT0017-4	13/035,964	2/26/2011	08/1/2011 JRE
SCOT0017-5	13/487,119	6/1/2012	4/16/2013 JRE
SCOT0017-6	13/802,384	3/13/2013	4/16/2013 JRE
SCOT0018-1	10/417/231	4/17/2003	01/11/2011 JRE
SCOT0018-2	11/900,065	9/10/2007	10/15/2010 JRE
SCOT0018-3	11/900,066	9/10/2007	1/11/2012 JRE
SCOT0018-4	12/383,289	3/23/2009	08/1/2011 JRE
SCOT0018-5	13/273,930	10/14/2011	1/11/2012 JRE
SCOT0018-6	13/551,097	7/17/2012	4/16/2013 JRE
SCOT0018-7	13/488,357	6/4/2012	9/9/2012 JRE
SCOT0018-8	13/488,395	6/4/2012	9/9/2012 JRE
SCOT0019-1	09/053,628	4/2/1998	1/11/2012 JRE
SCOT0019-2	09/644,098	8/23/2000	1/11/2012 JRE
SCOT0019-3	11/358,874	2/21/2006	1/11/2012 JRE
SCOT0019-4	12/799,894	5/4/2010	12/13/2010 JRE
SCOT0020-1	09/731,040	12/7/2000	1/11/2012 JRE
SCOT0020-2	11/512,701	8/29/2006	08/1/2011 JRE
SCOT0020-3	13/826,858	3/14/2013	4/16/2013 JRE
SCOT0020-4	13/797,744	3/12/2013	4/16/2013 JRE
SCOT0022-1	09/594,719	6/16/2000	4/16/2013 JRE
SCOT0022-2	11/519,467	9/12/2006	4/16/2013 JRE
SCOT0022-3	12/655,036	12/22/2009	08/1/2011 JRE
SCOT0022-4	13/423,650	3/19/2012	7/26/2012 JRE
SCOT0022-5	13/802,471	3/13/2013	4/16/2013 JRE
SCOT0023-1	08/772,222	12/20/1996	4/16/2013 JRE
SCOT0023-2	09/456,319	12/8/1999	4/16/2013 JRE
SCOT0023-3	11/826,234	12/30/2004	4/16/2013 JRE
SCOT0023-4	11/592,879	11/2/2006	4/16/2013 JRE

ALL REFERENCES CONSIDERED EXCEPT WHERE LINED THROUGH. //I.O./

Receipt date: 03/20/2015

11895388 - GAU: 2432

DOCKET REFERENCE	APPLICATION	FILING DATE	DATE CASE ADDED TO THIS MASTER LIST OF RELATED CASES
SCOT0023-5	12/798,959	4/14/2010	08/1/2011 JRE
SCOT0024-2	11/518,806	9/11/2006	08/1/2011 JRE
SCOT0024-3	13/429,396	3/25/2012	7/26/2012 JRE
SCOT0025-1	61/794,141	3/15/2013	4/16/2013JRE

ALL REFERENCES CONSIDERED EXCEPT WHERE LINED THROUGH. //I.O./

AS OF 1/12/2012, THE FOLLOWING TABLE COLLATES ADDITIONAL REFERENCES CITED IN ANY SCOT (SCOTT MOSKOWITZ) CASE

Date of Document Citing Reference	Atty Ref	Application Number	ID of paper in which references were cited	References checked to see if they existed in the master IDS (initials of person checking)	Reference Identifiers of New references in document, now added to master IDS
Sept 14, 2010	SCOT0 012-7	12/383,916	892	JRE	U#299
11/17/2010	ALL	N/A	Review of draft master IDS, correction to cite publications in lieu of filed applications, per RAN instructions.	JRE	P76-P82
12/9/2010	SCOT0 018-2	11/900,065	892	JRE	U303 & P83
11/30/2010	SCOT0 019-4	12/799,894	892	JRE	U304
11/21/2011	SCOT0 016-2	12/287,443	892	JRE	U305, U306 & U307
1/12/2012	SCOT0 011-8	12/803,194	892	JRE	U308
1/12/2012	SCOT0 014-5	12/655,002	892	JRE	U309
1/12/2012	SCOT0 017-4	13/035,964	892	JRE	U310-U316
1/12/2012	SCOT0 018-2	11/900,065	892	JRE	P84-P85
3/7/2012	SCOT0 018-2	11/900,065	892	JRE	P86 -P87 & U317
8/30/2012	SCOT0 016-3	13/413,691	892	JRE	U318 & U319

ALL REFERENCES CONSIDERED EXCEPT WHERE LINED THROUGH. //I.O./

9/17/2012	SCOT0014-6	13/556,420	Per RAN created CTS reminder	JRE	L212
11/26/2012	SCOT0017-4	13/035,964	Per RAN inst rec'vd 11/15/2012	JRE	U320 & L213-L217
4/16/2013	SCOT0017-4	13/035,964	Review of Patented case	JRE	U322-U326 & P88-P90
6/13/2013	SCOT0018-7	13/488,357	Per instructions received from RAN	JRE	U329-332 L218-L223
6/28/2013	SCOT0014-6	13/556,420	Per instructions received from RAN	JRE	U0333
1/21/2014			Per Instructions received from RAN on 1/7/2014	JRE	L229
2/6/2014	SCOT0017-6	13/802,384	Per instructions received from RAN on 1/30/2014	JRE	U335
4/7/2014			Per Instructions received from RAN on 4/7/2014	JRE	L231-L232
5/15/2014	SCOT0020-3	13/826,858	892 issued 4/21/2014	JRE	U379-U384
8/18/2014	SCOT0020-3	13/826,858	892 issued 8/18/2014	JRE	U385-U388
9/12/2014			Per Instructions received from RAN 9/12/2014	JRE	U389-393

10/13/2014			Per instructions received from RAN on 10/10/2014	JRE	U394-U398 and P98
10/17/2014			Per instructions received from BTM 10/17/2014	JRE	L233-L234
10/17/2014			Per instructions received from RAN (client sent references)	JRE	L235-L236
11/6/2014	SCOT0016-5	14/256,315	892	JRE	L237-L238
12/5/2014	SCOT0020-4	13/797,774	892	JRE	U399-U400
12/10/14	SCOT0017-7	14/094,987	892	JRE	U401
12/22/2014			Per BTM instructions	JRE	L239-L255
1/7/2015			Per RAN instructions	JRE	U-402
2/9/2015			Per RAN instructions	JRE	U-403
2/26/2015	SCOT0014-8	14/542,712	892	JRE	U404- U406
3/12/2015	SCOT0014-4	11/895,388	Appeal Decision	JRE	L256

NOTE: MPEP 609.02 Information Disclosure Statements in Continued Examinations or Continuing Applications [R-5] states in part that:

"2. Continuation Applications , Divisional Applications, or Continuation-In-Part Applications Filed Under 37 CFR 1.53(b)

The examiner will consider information which has been considered by the Office in a parent application when examining: (A) a continuation application filed under 37 CFR 1.53(b), (B) a divisional application filed under 37 CFR 1.53(b), or (C) a continuation-in-part application filed

under 37 CFR 1.53(b). A listing of the information need not be resubmitted in the continuing application unless the applicant desires the information to be printed on the patent"

See

<http://mpep.uspto.gov/RDMS/detail/manual/MPEP/e8r9/d0e18.xml#/manual/MPEP/e8r9/d0e53250.xml> (8/2012)

Accordingly, we are submitting only references not cited in the parent application.

Please consider the references cited herein.

Date signed: 3/19/2015

Signature: /BruceMargulies/
Printed Name: Bruce T. Margulies
Attorney of Record

JRE

Printed: March 20, 2015 (12:01pm)

Y:\Clients\SCOT Scott A Moskowitz and Wistaria Trading,
Inc\SCOT0014-4\Drafts\IDS_SCOT0014-4_3-12-2015.wpd

05/31/2015

/Izunna Okeke/

EAST Search History

EAST Search History (Prior Art)

Ref #	Hits	Search Query	DBs	Default Operator	Plurals	Time Stamp
S72	18223	713/165,176,161,167,164;380/201,228,229.ccls.	US-PGPUB; USPAT; USOCR; FPRS; EPO; JPO; DERWENT; IBM_TDB	AND	ON	2015/05/31 22:11
S73	39333	H04L63/0428;H04L2209/608;H04L2209/60.cpc.	US-PGPUB; USPAT; USOCR; FPRS; EPO; JPO; DERWENT; IBM_TDB	AND	ON	2015/05/31 22:12
S74	113	(watermark same ((software or program or application))) and (@ad<"19960117")	US-PGPUB; USPAT; USOCR; FPRS; EPO; JPO; DERWENT; IBM_TDB	AND	ON	2015/05/31 22:13
S75	2	S73 and S74	US-PGPUB; USPAT; USOCR; FPRS; EPO; JPO; DERWENT; IBM_TDB	AND	ON	2015/05/31 22:13
S76	23	(watermark near3 ((software or program or application))) and (@ad<"19960117")	US-PGPUB; USPAT; USOCR; FPRS; EPO; JPO; DERWENT; IBM_TDB	AND	ON	2015/05/31 22:13
S77	2	S73 and S76	US-PGPUB; USPAT; USOCR; FPRS; EPO; JPO; DERWENT; IBM_TDB	AND	ON	2015/05/31 22:13
S78	6	(watermark\$3 adj ((software or program or application))) and (@ad<"19960117")	US-PGPUB; USPAT; USOCR; FPRS; EPO; JPO; DERWENT; IBM_TDB	AND	ON	2015/05/31 22:13
S79	0	S73 and S78	US-PGPUB;	AND	ON	2015/05/31

EAST Search History

			USPAT; USOCR; FPRS; EPO; JPO; DERWENT; IBM_TDB			22:13
S80	11	(watermark same ((software))) and (@ad<"19960117")	US-PGPUB; USPAT; USOCR; FPRS; EPO; JPO; DERWENT; IBM_TDB	AND	ON	2015/05/31 22:13
S81	1	S73 and S80	US-PGPUB; USPAT; USOCR; FPRS; EPO; JPO; DERWENT; IBM_TDB	AND	ON	2015/05/31 22:13
S82	12	(watermark\$3 same ((software))) and (@ad<"19960117")	US-PGPUB; USPAT; USOCR; FPRS; EPO; JPO; DERWENT; IBM_TDB	AND	ON	2015/05/31 22:13
S83	1	S73 and S82	US-PGPUB; USPAT; USOCR; FPRS; EPO; JPO; DERWENT; IBM_TDB	AND	ON	2015/05/31 22:13
S84	62	(watermark with (software or program or application)) and (@ad<"19960117")	US-PGPUB; USPAT; USOCR; FPRS; EPO; JPO; DERWENT; IBM_TDB	AND	ON	2015/05/31 22:13
S85	2	S73 and S84	US-PGPUB; USPAT; USOCR; FPRS; EPO; JPO; DERWENT; IBM_TDB	AND	ON	2015/05/31 22:13
S86	114	((watermark or steganograph\$5) same ((software or program or application))) and (@ad<"19960117")	US-PGPUB; USPAT; USOCR; FPRS; EPO; JPO; DERWENT; IBM_TDB	AND	ON	2015/05/31 22:13
S87	3	S73 and S86	US-PGPUB; USPAT; USOCR; FPRS; EPO; JPO; DERWENT;	AND	ON	2015/05/31 22:13

			IBM_TDB			
S88	41	((watermark or steganograph\$5) near5 ((software or program or application))) and (@ad<"19960117")	US-PGPUB; USPAT; USOCR; FPRS; EPO; JPO; DERWENT; IBM_TDB	AND	ON	2015/05/31 22:13
S89	2	S73 and S88	US-PGPUB; USPAT; USOCR; FPRS; EPO; JPO; DERWENT; IBM_TDB	AND	ON	2015/05/31 22:13
S90	62	((watermark or steganograph\$5) with ((software or program or application))) and (@ad<"19960117")	US-PGPUB; USPAT; USOCR; FPRS; EPO; JPO; DERWENT; IBM_TDB	AND	ON	2015/05/31 22:13
S91	2	S73 and S90	US-PGPUB; USPAT; USOCR; FPRS; EPO; JPO; DERWENT; IBM_TDB	AND	ON	2015/05/31 22:13
S92	5	((watermark or steganograph\$5) with ((software))) and (@ad<"19960117")	US-PGPUB; USPAT; USOCR; FPRS; EPO; JPO; DERWENT; IBM_TDB	AND	ON	2015/05/31 22:13
S93	1	S73 and S92	US-PGPUB; USPAT; USOCR; FPRS; EPO; JPO; DERWENT; IBM_TDB	AND	ON	2015/05/31 22:13
S94	426	((watermark or steganograph\$5) and ((software or program or application))) and (@ad<"19960117")	US-PGPUB; USPAT; USOCR; FPRS; EPO; JPO; DERWENT; IBM_TDB	AND	ON	2015/05/31 22:13
S95	4	S73 and S94	US-PGPUB; USPAT; USOCR; FPRS; EPO; JPO; DERWENT; IBM_TDB	AND	ON	2015/05/31 22:13
S96	82	((watermark or steganograph\$5) and ((software))) and (@ad<"19960117")	US-PGPUB; USPAT; USOCR; FPRS;	AND	ON	2015/05/31 22:13

			EPO; JPO; DERWENT; IBM_TDB			
S97	3	S73 and S96	US-PGPUB; USPAT; USOCR; FPRS; EPO; JPO; DERWENT; IBM_TDB	AND	ON	2015/05/31 22:13
S98	81	((watermark) and ((software))) and (@ad<"19960117")	US-PGPUB; USPAT; USOCR; FPRS; EPO; JPO; DERWENT; IBM_TDB	AND	ON	2015/05/31 22:13
S99	3	S73 and S98	US-PGPUB; USPAT; USOCR; FPRS; EPO; JPO; DERWENT; IBM_TDB	AND	ON	2015/05/31 22:13
S100	41	(watermark near5 ((software or program or application))) and (@ad<"19960117")	US-PGPUB; USPAT; USOCR; FPRS; EPO; JPO; DERWENT; IBM_TDB	AND	ON	2015/05/31 22:13
S101	2	S73 and S100	US-PGPUB; USPAT; USOCR; FPRS; EPO; JPO; DERWENT; IBM_TDB	AND	ON	2015/05/31 22:13
S102	53	(watermark near5 ((code or software or program or application))) and (@ad<"19960117")	US-PGPUB; USPAT; USOCR; FPRS; EPO; JPO; DERWENT; IBM_TDB	AND	ON	2015/05/31 22:13
S103	2	S73 and S102	US-PGPUB; USPAT; USOCR; FPRS; EPO; JPO; DERWENT; IBM_TDB	AND	ON	2015/05/31 22:13
S104	64	(watermark\$3 near5 (code or software or program or application)) and (@ad<"19960117")	US-PGPUB; USPAT; USOCR; FPRS; EPO; JPO; DERWENT; IBM_TDB	AND	ON	2015/05/31 22:13
S105	2	S73 and S104	US-PGPUB; USPAT;	AND	ON	2015/05/31 22:13

EAST Search History

			USOCR; FPRS; EPO; JPO; DERWENT; IBM_TDB			
S106	110	(watermark\$3 with (code or software or program or application)) and (@ad<"19960117")	US-PGPUB; USPAT; USOCR; FPRS; EPO; JPO; DERWENT; IBM_TDB	AND	ON	2015/05/31 22:13
S107	2	S73 and S106	US-PGPUB; USPAT; USOCR; FPRS; EPO; JPO; DERWENT; IBM_TDB	AND	ON	2015/05/31 22:13
S108	12	((watermark or steganograph\$5) same ((software))) and (@ad<"19960117")	US-PGPUB; USPAT; USOCR; FPRS; EPO; JPO; DERWENT; IBM_TDB	AND	ON	2015/05/31 22:15
S109	1	S73 and S108	US-PGPUB; USPAT; USOCR; FPRS; EPO; JPO; DERWENT; IBM_TDB	AND	ON	2015/05/31 22:15
S110	7	((embed\$4 near3 watermark)) and (@ad<"19960117")	US-PGPUB; USPAT; USOCR; FPRS; EPO; JPO; DERWENT; IBM_TDB	AND	ON	2015/05/31 22:15
S111	0	S73 and S110	US-PGPUB; USPAT; USOCR; FPRS; EPO; JPO; DERWENT; IBM_TDB	AND	ON	2015/05/31 22:15
S112	10	((embed\$4 near5 watermark)) and (@ad<"19960117")	US-PGPUB; USPAT; USOCR; FPRS; EPO; JPO; DERWENT; IBM_TDB	AND	ON	2015/05/31 22:15
S113	1	S73 and S112	US-PGPUB; USPAT; USOCR; FPRS; EPO; JPO; DERWENT; IBM_TDB	AND	ON	2015/05/31 22:15

EAST Search History

S114	22	((embed\$4 or insert\$3) near5 watermark) and (@ad< "19960117")	US-PGPUB; USPAT; USOCR; FPRS; EPO; JPO; DERWENT; IBM_TDB	AND	ON	2015/05/31 22:15
S115	1	S73 and S114	US-PGPUB; USPAT; USOCR; FPRS; EPO; JPO; DERWENT; IBM_TDB	AND	ON	2015/05/31 22:15
S116	39	((electronic or digital) near5 watermark) and (@ad< "19960117")	US-PGPUB; USPAT; USOCR; FPRS; EPO; JPO; DERWENT; IBM_TDB	AND	ON	2015/05/31 22:15
S117	3	S73 and S116	US-PGPUB; USPAT; USOCR; FPRS; EPO; JPO; DERWENT; IBM_TDB	AND	ON	2015/05/31 22:15
S118	34	((electronic or digital) near3 watermark) and (@ad< "19960117")	US-PGPUB; USPAT; USOCR; FPRS; EPO; JPO; DERWENT; IBM_TDB	AND	ON	2015/05/31 22:15
S119	3	S73 and S118	US-PGPUB; USPAT; USOCR; FPRS; EPO; JPO; DERWENT; IBM_TDB	AND	ON	2015/05/31 22:15
S120	37	((embed\$4 or insert\$3) with watermark) and (@ad< "19960117")	US-PGPUB; USPAT; USOCR; FPRS; EPO; JPO; DERWENT; IBM_TDB	AND	ON	2015/05/31 22:15
S121	1	S73 and S120	US-PGPUB; USPAT; USOCR; FPRS; EPO; JPO; DERWENT; IBM_TDB	AND	ON	2015/05/31 22:15
S122	4648	(watermark near3 (software or program or application))	US-PGPUB; USPAT; USOCR; FPRS; EPO; JPO;	AND	ON	2015/05/31 22:16

			DERWENT; IBM_TDB			
S123	894	S71 and S122	US-PGPUB; USPAT; USOCR; FPRS; EPO; JPO; DERWENT; IBM_TDB	AND	ON	2015/05/31 22:16
S124	218	(watermark near3 (software or program or application)) and (@ad<"19960117" or @rlad<"19960117")	US-PGPUB; USPAT; USOCR; FPRS; EPO; JPO; DERWENT; IBM_TDB	AND	ON	2015/05/31 22:16
S125	38	S71 and S124	US-PGPUB; USPAT; USOCR; FPRS; EPO; JPO; DERWENT; IBM_TDB	AND	ON	2015/05/31 22:16
S126	23	(watermark near3 (software or program or application)) and (@ad<"19960117")	US-PGPUB; USPAT; USOCR; FPRS; EPO; JPO; DERWENT; IBM_TDB	AND	ON	2015/05/31 22:16
S127	4	S71 and S126	US-PGPUB; USPAT; USOCR; FPRS; EPO; JPO; DERWENT; IBM_TDB	AND	ON	2015/05/31 22:16

EAST Search History (Interference)

Ref #	Hits	Search Query	DBs	Default Operator	Plurals	Time Stamp
S129	2	((digital adj sample) and (encoded adj format adj information) and (degraded adj quality)).clm.	US-PGPUB; USPAT; UPAD	AND	ON	2015/05/31 22:22
S130	2	((digital adj sample) and (encoded adj format adj information) and (degraded adj quality) and (predetermined adj key)).clm.	US-PGPUB; USPAT; UPAD	AND	ON	2015/05/31 22:23
S131	1	((license adj information) and (digital adj sample) and (encoded adj format adj information) and (degraded adj quality) and (predetermined adj key)).clm.	US-PGPUB; USPAT; UPAD	AND	ON	2015/05/31 22:23
S132	1	((installation with software) and (license adj information) and (digital adj sample) and (encoded adj format adj information) and (degraded adj quality) and (predetermined adj key)).clm.	US-PGPUB; USPAT; UPAD	AND	ON	2015/05/31 22:23
S133	1	((installation with software) and (license adj	US-	AND	ON	2015/05/31

EAST Search History

		information) and (digital adj sample) and (degraded adj quality) and (predetermined adj key)).clm.	PGPUB; USPAT; UPAD			22:24
S134	1	((watermarked adj software) and (installation with software) and (license adj information) and (digital adj sample) and (degraded adj quality) and (predetermined adj key)).clm.	US-PGPUB; USPAT; UPAD	AND	ON	2015/05/31 22:24
S135	1	((watermarked adj software) and (installation with software) and (digital adj sample) and (degraded adj quality) and (predetermined adj key)).clm.	US-PGPUB; USPAT; UPAD	AND	ON	2015/05/31 22:24

5/ 31/ 2015 11:54:58 PM

C:\ Users\ iokeke\ Documents\ EAST\ Workspaces\ 11895388.wsp

Issue Classification 	Application/Control No. 11895388	Applicant(s)/Patent Under Reexamination MOSKOWITZ, SCOTT A.	
	Examiner IZUNNA OKEKE	Art Unit 2432	

CPC					
Symbol				Type	Version
G06F	21		10	F	2013-01-01
G06F	21		125	I	2013-01-01
G06F	21		16	I	2013-01-01
G06F	21		335	I	2013-01-01
G06F	2211		007	A	2013-01-01
G06F	2221		0737	A	2013-01-01
G06F	2221		2107	A	2013-01-01
G06T	1		0021	I	2013-01-01
G06T	2201		0064	A	2013-01-01
G06T	2201		0083	A	2013-01-01
H04L	9		065	I	2013-01-01
H04L	9		3236	I	2013-01-01
H04L	9		3247	I	2013-01-01
H04L	2209		605	A	2013-01-01
H04L	2209		608	A	2013-01-01

CPC Combination Sets				
Symbol	Type	Set	Ranking	Version

NONE		Total Claims Allowed:	
(Assistant Examiner)	(Date)	14	
/IZUNNA OKEKE/ Primary Examiner.Art Unit 2432	05/31/2015	O.G. Print Claim(s)	O.G. Print Figure
(Primary Examiner)	(Date)	34	1

Issue Classification 	Application/Control No. 11895388	Applicant(s)/Patent Under Reexamination MOSKOWITZ, SCOTT A.
	Examiner IZUNNA OKEKE	Art Unit 2432

US ORIGINAL CLASSIFICATION						INTERNATIONAL CLASSIFICATION														
CLASS		SUBCLASS				CLAIMED					NON-CLAIMED									
713		176				G	0	6	F	21 / 16 (2013.01.01)										
CROSS REFERENCE(S)																				
CLASS	SUBCLASS (ONE SUBCLASS PER BLOCK)																			
713	164																			

NONE		Total Claims Allowed:	
		14	
(Assistant Examiner)	(Date)	O.G. Print Claim(s)	O.G. Print Figure
/IZUNNA OKEKE/ Primary Examiner. Art Unit 2432	05/31/2015	34	1
(Primary Examiner)	(Date)		

Issue Classification 	Application/Control No. 11895388	Applicant(s)/Patent Under Reexamination MOSKOWITZ, SCOTT A.
	Examiner IZUNNA OKEKE	Art Unit 2432

<input type="checkbox"/> Claims renumbered in the same order as presented by applicant																<input type="checkbox"/> CPA		<input type="checkbox"/> T.D.		<input type="checkbox"/> R.1.47	
Final	Original	Final	Original	Final	Original	Final	Original	Final	Original	Final	Original	Final	Original	Final	Original						
	32		48		64																
	33		49																		
1	34		50																		
	35		51																		
2	36		52																		
	37		53																		
3	38	10	54																		
	39		55																		
4	40		56																		
5	41		57																		
6	42	11	58																		
7	43		59																		
8	44	12	60																		
9	45	13	61																		
	46	14	62																		
	47		63																		

NONE		Total Claims Allowed:	
		14	
(Assistant Examiner)	(Date)	O.G. Print Claim(s)	O.G. Print Figure
/IZUNNA OKEKE/ Primary Examiner.Art Unit 2432	05/31/2015	34	1
(Primary Examiner)	(Date)		

Neifeld Docket No: SCOT0014-4

Application/Patent No: 11/895,388

USPTO CONFIRMATION NO: 2103

File/Issue Date: 8/24/2007

Inventor/title: Moskowitz/ Data protection method and device

Examiner/ArtUnit: Izunna OKEKE/2432

ENTITY STATUS: SMALL (CONVERT UPON ALLOWANCE TO LARGE)

Priority: Application No. 09/046,627 (which issued July 22, 2003, as U.S. Patent No. 6,598,162)

ASSISTANT COMMISSIONER FOR PATENTS

ALEXANDRIA, VA 22313

AMENDMENT AFTER ALLOWANCE (37 CFR 1.312)

Dear Sir or Madam:

In response to the notice of allowance mailed June 4, 2015, the applicant responds as follows:

REMARKS

The Applicant requests entry of the amendments to claims 43, 44, and 58 presented with this filing. The amendments are to clarify issues relating to antecedent basis.

The Applicant respectfully requests prompt entry of this amendment.

Date 6/5/2015

Respectfully,

/BruceMargulies64175/

Bruce Margulies, REG. NO. 64,175

ATTORNEY OF RECORD

I. IN THE CLAIMS

1-33. (Canceled).

34. (Previously Presented) A computer-based method for modifying software, comprising:

receiving, in a computer having a processor and memory, software, wherein said software provides a specified functionality;

embedding a watermark into said software, using said computer, said watermark encoding at least one first license code, thereby resulting in a first license code encoded watermarked software; and

wherein said first license code encoded watermarked software is configured to query a user for personalization information during its installation.

35. (Canceled).

36. (Previously Presented) A computer-based method for modifying software, comprising:

receiving, in a computer having a processor and memory, software, wherein said software provides a specified functionality;

embedding a watermark into said software, using said computer, said watermark encoding at least one first license code, thereby resulting in a first license code encoded watermarked software;

wherein said watermark is accessible with a key; and

said key enables said first license code encoded watermarked software to provide said specified functionality.

37. (Canceled).

38. (Previously Presented) A computer-based method for modifying software, comprising:

receiving, in a computer having a processor and memory, software, wherein said software provides a specified functionality;

embedding a watermark into said software, using said computer, said watermark encoding at least one first license code, thereby resulting in a first license code encoded watermarked software; and

wherein the step of embedding the software with a watermark is performed during execution of the software.

39. (Canceled).

40. (Previously Presented) An article of manufacture comprising a machine readable medium, having thereon stored instructions adapted to be executed by a processor of a computer system, said computer system including a memory, which instructions when executed by said computer system result in a process comprising:

said computer system storing a software in said memory;

said computer system receiving licensing information as an input and using said licensing information in an algorithm to identify a watermark in said software.

41. (Previously Presented) The article of manufacture of claim 40, wherein said watermark encodes therein information defining an executable code providing a functionality of said software.

42. (Original) The article of manufacture of claim 40, wherein the watermark affects functionality of the watermarked software.

43. (Currently Amended) The article of manufacture of claim 41, wherein said instructions comprise decode instructions for said computer system to use said licensing information to generate a decode key for decoding said software.

44. (Currently Amended) The article of manufacture of claim 43, wherein said ~~identifying~~ licensing information comprises a license key, and said decode instructions instruct said computer to determine said license key from said licensing information and to generate said decode key using said license key.

45. (Previously Presented) The article of manufacture of claim 40:
wherein said watermark encodes a license key;

said instructions include a prompt to enter licensing information;
wherein said software provides a certain functionality after receipt of licensing information in response to said prompt only if said licensing information comprises a license key encoded in said watermark.

46 – 53. (Canceled).

54. (Previously Presented) A computer-based system for modifying software, comprising:
a computer having a processor and memory;
wherein said computer is programmed to receive software that provides a specified functionality when installed on a computer system;
wherein said computer is programmed to embed a watermark into said software;
wherein said watermark encodes at least one first license code, thereby resulting in a first license code encoded watermarked software; and
wherein said first license code encoded watermarked software is designed to prompt for entry of licensing information and only provides a certain functionality if licensing information entered in response to said prompt comprises at least one of said at least one first license code encoded in said watermark.

55 – 57. (Canceled).

58. (Currently Amended) A method for licensed software use, the method comprising:
loading a software product on a computer, said computer comprising a processor, memory, an input, and an output, so that said computer is programmed to execute said software product;
said software product outputting a prompt for input of license information; and
said software product using license information entered via said input in response to said prompt in a routine designed to decode a first license code encoded in said software product.

59. (Canceled).

60. (Previously Presented) A method for encoding software code using a computer having a processor and memory, comprising:
storing a software code in said memory;
wherein said software code comprises a first code resource and provides a specified underlying functionality when installed on a computer system; and
encoding, by said computer using at least a first license key and an encoding algorithm, said software code, to form a first license key encoded software code; and
wherein, when installed on a computer system, said first license key encoded software code will provide said specified underlying functionality only after receipt of said first license key.

61. (Previously Presented) A method for encoding software code using a computer having a processor and memory, comprising:
storing a software code in said memory;
wherein said software code comprises a first code resource and provides a specified underlying functionality when installed on a computer system; and
modifying, by said computer, using a first license key and an encoding algorithm, said software code, to form a modified software code; and
wherein said modifying comprises encoding said first code resource to form an encoded first code resource;
wherein said modified software code comprises said encoded first code resource, and a decode resource for decoding said encoded first code resource;
wherein said decode resource is configured to decode said encoded first code resource upon receipt of said first license key.

62. (Previously Presented) A method for encoding software code using a computer having a processor and memory, comprising:
storing a software code in said memory;
wherein said software code defines software code interrelationships between code resources that result in a specified underlying functionality when installed on a computer system;
and
encoding, by said computer using at least a first license key and an encoding algorithm, said software code, to form a first license key encoded software code in which at least one of said software code interrelationships are encoded.

63-64. (Canceled).

Printed: June 5, 2015 (8:34pm)
Y:\Clients\SCOT Scott A Moskowitz and Wistaria Trading,
Inc\SCOT0014-4\Drafts\AmendmentAfterAllowance_SCOT0014-4_6-5-2015.wpd

Electronic Acknowledgement Receipt

EFS ID:	22556603
Application Number:	11895388
International Application Number:	
Confirmation Number:	2103
Title of Invention:	Data protection method and device
First Named Inventor/Applicant Name:	Scott A. Moskowitz
Customer Number:	31518
Filer:	Bruce Talbot Margulies
Filer Authorized By:	
Attorney Docket Number:	SCOT0014-4
Receipt Date:	05-JUN-2015
Filing Date:	24-AUG-2007
Time Stamp:	20:45:30
Application Type:	Utility under 35 USC 111(a)

Payment information:

Submitted with Payment	no
------------------------	----

File Listing:

Document Number	Document Description	File Name	File Size(Bytes)/ Message Digest	Multi Part /.zip	Pages (if appl.)
1		AmendmentAfterAllowance_S COT0014-4_6-5-2015c.pdf	51551 <small>46eb8072dbd2312405fb199816e43f4cae7 6650a</small>	yes	9

Multipart Description/PDF files in .zip description		
Document Description	Start	End
Transmittal Letter	1	1
Amendment after Notice of Allowance (Rule 312)	2	2
Claims	3	9

Warnings:

Information:

Total Files Size (in bytes):	51551
-------------------------------------	-------

This Acknowledgement Receipt evidences receipt on the noted date by the USPTO of the indicated documents, characterized by the applicant, and including page counts, where applicable. It serves as evidence of receipt similar to a Post Card, as described in MPEP 503.

New Applications Under 35 U.S.C. 111

If a new application is being filed and the application includes the necessary components for a filing date (see 37 CFR 1.53(b)-(d) and MPEP 506), a Filing Receipt (37 CFR 1.54) will be issued in due course and the date shown on this Acknowledgement Receipt will establish the filing date of the application.

National Stage of an International Application under 35 U.S.C. 371

If a timely submission to enter the national stage of an international application is compliant with the conditions of 35 U.S.C. 371 and other applicable requirements a Form PCT/DO/EO/903 indicating acceptance of the application as a national stage submission under 35 U.S.C. 371 will be issued in addition to the Filing Receipt, in due course.

New International Application Filed with the USPTO as a Receiving Office

If a new international application is being filed and the international application includes the necessary components for an international filing date (see PCT Article 11 and MPEP 1810), a Notification of the International Application Number and of the International Filing Date (Form PCT/RO/105) will be issued in due course, subject to prescriptions concerning national security, and the date shown on this Acknowledgement Receipt will establish the international filing date of the application.

Neifeld Docket No: SCOT0014-4

Application/Patent No: 11/895,388

USPTO CONFIRMATION NO: 2103

File/Issue Date: 8/24/2007

Inventor/title: Moskowitz/ Data protection method and device

Examiner/ArtUnit: Izunna OKEKE/2432

ENTITY STATUS: SMALL (CONVERT UPON ALLOWANCE TO LARGE)

Priority: Application No. 09/046,627 (which issued July 22, 2003, as U.S. Patent No. 6,598,162)

1. **37 CFR 1.25(b) SELECTED AUTHORIZATION TO CHARGE UNDERPAYMENT AND REFUND OVERPAYMENTS TO DEPOSIT ACCOUNT 50-2106.** The undersigned is an authorized signor for deposit account 50-2106 and authorizes charges for applications filed by Neifeld IP Law, PC, specified in 37 CFR 1.16 (national filing, search, exam fees); in 37 CFR 1.17 (processing, including petition fees); and 37 CFR 1.18 (post allowance, including issue fees) *except that*: the undersigned does not authorize charges for invention claims (specified in 1.16(h); (I); and (k)). The undersigned authorizes charges for a 35 USC 371 national stage entry of a PCT international application identified in 37 CFR 1.492(a)-(c) and (h)-(j), but not (d)-(g) (all fees other than invention claims fees).

2. **FEES (PAID HEREWITH BY EFS CREDIT CARD SUBMISSION) \$:0**

3. **THE FOLLOWING DOCUMENTS ARE SUBMITTED HEREWITH:**
37 CFR 1.312 AMENDMENT AFTER ALLOWANCE (8 pages)

4. **FOR INTERNAL NEIFELD IP LAW, PC USE ONLY**

Disbursements: None.

Service Fees: None.

INITIALS OF PERSON WHO **ENTERED** ACCOUNTING DATA:

ATTORNEY SIGNATURE (AUTHORIZING DEPOSIT ACCOUNT)

DATE: 6/5/2015

SIGNATURE: /BruceMargulies/

Printed: June 5, 2015 (8:34pm)

BRUCE MARGULIES, REG. NO. 64175

Y:\Clients\SCOT Scott A Moskowitz and Wistaria Trading,

Inc\SCOT0014-4\Drafts\AmendmentAfterAllowance_SCOT0014-4_6-5-2015.wpd

PART B - FEE(S) TRANSMITTAL

**Complete and send this form, together with applicable fee(s), to: Mail Mail Stop ISSUE FEE
 Commissioner for Patents
 P.O. Box 1450
 Alexandria, Virginia 22313-1450
 or Fax (571)-273-2885**

INSTRUCTIONS: This form should be used for transmitting the ISSUE FEE and PUBLICATION FEE (if required). Blocks 1 through 5 should be completed where appropriate. All further correspondence including the Patent, advance orders and notification of maintenance fees will be mailed to the current correspondence address as indicated unless corrected below or directed otherwise in Block 1, by (a) specifying a new correspondence address; and/or (b) indicating a separate "FEE ADDRESS" for maintenance fee notifications.

CURRENT CORRESPONDENCE ADDRESS (Note: Use Block 1 for any change of address)

31518 7590 06/04/2015
 NEIFELD IP LAW, PC
 4813-B EISENHOWER AVENUE
 ALEXANDRIA, VA 22304

Note: A certificate of mailing can only be used for domestic mailings of the Fee(s) Transmittal. This certificate cannot be used for any other accompanying papers. Each additional paper, such as an assignment or formal drawing, must have its own certificate of mailing or transmission.

Certificate of Mailing or Transmission

I hereby certify that this Fee(s) Transmittal is being deposited with the United States Postal Service with sufficient postage for first class mail in an envelope addressed to the Mail Stop ISSUE FEE address above, or being facsimile transmitted to the USPTO (571) 273-2885, on the date indicated below.

(Depositor's name)
(Signature)
(Date)

APPLICATION NO.	FILING DATE	FIRST NAMED INVENTOR	ATTORNEY DOCKET NO.	CONFIRMATION NO.
11/895,388	08/24/2007	Scott A. Moskowitz	SCOT0014-4	2103

TITLE OF INVENTION: Data protection method and device

APPLN. TYPE	ENTITY STATUS	ISSUE FEE DUE	PUBLICATION FEE DUE	PREV. PAID ISSUE FEE	TOTAL FEE(S) DUE	DATE DUE
nonprovisional	SMALL Large	\$480 \$960	\$0	\$0	\$480 \$960	09/04/2015

EXAMINER	ART UNIT	CLASS-SUBCLASS
OKEKE, IZUNNA	2432	713-176000

<p>1. Change of correspondence address or indication of "Fee Address" (37 CFR 1.363).</p> <p><input type="checkbox"/> Change of correspondence address (or Change of Correspondence Address Form PTO/SB/122) attached.</p> <p><input type="checkbox"/> "Fee Address" indication (or "Fee Address" Indication form PTO/SB/47; Rev 03-02 or more recent) attached. Use of a Customer Number is required.</p>	<p>2. For printing on the patent front page, list</p> <p>(1) The names of up to 3 registered patent attorneys or agents OR, alternatively, 1 <u>Neifeld IP Law, PC</u></p> <p>(2) The name of a single firm (having as a member a registered attorney or agent) and the names of up to 2 registered patent attorneys or agents. If no name is listed, no name will be printed. 2 _____</p> <p>3 _____</p>
---	---

3. ASSIGNEE NAME AND RESIDENCE DATA TO BE PRINTED ON THE PATENT (print or type)

PLEASE NOTE: Unless an assignee is identified below, no assignee data will appear on the patent. If an assignee is identified below, the document has been filed for recordation as set forth in 37 CFR 3.11. Completion of this form is NOT a substitute for filing an assignment.

(A) NAME OF ASSIGNEE _____ (B) RESIDENCE: (CITY and STATE OR COUNTRY) _____

Please check the appropriate assignee category or categories (will not be printed on the patent): Individual Corporation or other private group entity Government

<p>4a. The following fee(s) are submitted:</p> <p><input checked="" type="checkbox"/> Issue Fee</p> <p><input type="checkbox"/> Publication Fee (No small entity discount permitted)</p> <p><input checked="" type="checkbox"/> Advance Order - # of Copies <u>three</u></p>	<p>4b. Payment of Fee(s): (Please first reapply any previously paid issue fee shown above)</p> <p><input type="checkbox"/> A check is enclosed.</p> <p><input checked="" type="checkbox"/> Payment by credit card. Form PTO 208 is attached. xxxxxxxxxx by EFS authorization.</p> <p><input checked="" type="checkbox"/> The director is hereby authorized to charge the required fee(s), any deficiency, or credits any overpayment, to Deposit Account Number <u>50-2106</u> (enclose an extra copy of this form).</p>
--	--

5. Change in Entity Status (from status indicated above)

Applicant certifying micro entity status. See 37 CFR 1.29

Applicant asserting small entity status. See 37 CFR 1.27

Applicant changing to regular undiscounted fee status.

NOTE: Absent a valid certification of Micro Entity Status (see forms PTO/SB/15A and 15B), issue fee payment in the micro entity amount will not be accepted at the risk of application abandonment.

NOTE: If the application was previously under micro entity status, checking this box will be taken to be a notification of loss of entitlement to micro entity status.

NOTE: Checking this box will be taken to be a notification of loss of entitlement to small or micro entity status, as applicable.

NOTE: This form must be signed in accordance with 37 CFR 1.31 and 1.33. See 37 CFR 1.4 for signature requirements and certifications.

Authorized Signature /BruceMargulies/ Date 6/11/2015

Typed or printed name Bruce T. Margulies Registration No. 64,175

Electronic Patent Application Fee Transmittal

Application Number:	11895388			
Filing Date:	24-Aug-2007			
Title of Invention:	Data protection method and device			
First Named Inventor/Applicant Name:	Scott A. Moskowitz			
Filer:	Bruce Talbot Margulies			
Attorney Docket Number:	SCOT0014-4			
Filed as Large Entity				
Filing Fees for Utility under 35 USC 111(a)				
Description	Fee Code	Quantity	Amount	Sub-Total in USD(\$)
Basic Filing:				
Pages:				
Claims:				
Miscellaneous-Filing:				
Petition:				
Patent-Appeals-and-Interference:				
Post-Allowance-and-Post-Issuance:				
Utility Appl Issue Fee	1501	1	960	960

Description	Fee Code	Quantity	Amount	Sub-Total in USD(\$)
Extension-of-Time:				
Miscellaneous:				
Printed Copy of Patent - No Color	8001	3	3	9
Total in USD (\$)				969

Electronic Acknowledgement Receipt

EFS ID:	22598522
Application Number:	11895388
International Application Number:	
Confirmation Number:	2103
Title of Invention:	Data protection method and device
First Named Inventor/Applicant Name:	Scott A. Moskowitz
Customer Number:	31518
Filer:	Bruce Talbot Margulies
Filer Authorized By:	
Attorney Docket Number:	SCOT0014-4
Receipt Date:	11-JUN-2015
Filing Date:	24-AUG-2007
Time Stamp:	10:27:04
Application Type:	Utility under 35 USC 111(a)

Payment information:

Submitted with Payment	yes
Payment Type	Credit Card
Payment was successfully received in RAM	\$ 969
RAM confirmation Number	10110
Deposit Account	
Authorized User	

The Director of the USPTO is hereby authorized to charge indicated fees and credit any overpayment as follows:

File Listing:

Document Number	Document Description	File Name	File Size(Bytes)/ Message Digest	Multi Part /.zip	Pages (if appl.)
1		FilingOfIssueFeeTransmittal_SCOT0014-4_6-11-2015c.pdf	193970 feb799a602a3c51a2fafcdea20384e02df883496	yes	2

Multipart Description/PDF files in .zip description

Document Description	Start	End
Transmittal Letter	1	1
Issue Fee Payment (PTO-85B)	2	2

Warnings:

Information:

2	Fee Worksheet (SB06)	fee-info.pdf	32347 7821ab47fbc0d84cc8d03a360a59c85725de0cc5	no	2
---	----------------------	--------------	---	----	---

Warnings:

Information:

Total Files Size (in bytes): 226317

This Acknowledgement Receipt evidences receipt on the noted date by the USPTO of the indicated documents, characterized by the applicant, and including page counts, where applicable. It serves as evidence of receipt similar to a Post Card, as described in MPEP 503.

New Applications Under 35 U.S.C. 111

If a new application is being filed and the application includes the necessary components for a filing date (see 37 CFR 1.53(b)-(d) and MPEP 506), a Filing Receipt (37 CFR 1.54) will be issued in due course and the date shown on this Acknowledgement Receipt will establish the filing date of the application.

National Stage of an International Application under 35 U.S.C. 371

If a timely submission to enter the national stage of an international application is compliant with the conditions of 35 U.S.C. 371 and other applicable requirements a Form PCT/DO/EO/903 indicating acceptance of the application as a national stage submission under 35 U.S.C. 371 will be issued in addition to the Filing Receipt, in due course.

New International Application Filed with the USPTO as a Receiving Office

If a new international application is being filed and the international application includes the necessary components for an international filing date (see PCT Article 11 and MPEP 1810), a Notification of the International Application Number and of the International Filing Date (Form PCT/RO/105) will be issued in due course, subject to prescriptions concerning national security, and the date shown on this Acknowledgement Receipt will establish the international filing date of the application.

NEIFELD REF: SCOT0014-4

Neifeld Docket No: SCOT0014-4

Application/Patent No: 11/895,388

USPTO CONFIRMATION NO: 2103

File/Issue Date: 8/24/2007

Inventor/title: Moskowitz/ Data protection method and device

Examiner/ArtUnit: Izunna OKEKE/2432

ENTITY STATUS: LARGE

Priority: Application No. 09/046,627, which issued July 22, 2003, as U.S. Patent No. 6,598,162

1. 37 CFR 1.25(b) SELECTED AUTHORIZATION TO CHARGE

UNDERPAYMENT AND REFUND OVERPAYMENTS TO DEPOSIT ACCOUNT 50-

2106. The undersigned is an authorized signor for deposit account 50-2106 and authorizes charges for applications filed by Neifeld IP Law, PC, specified in 37 CFR 1.16 (national filing, search, exam fees); in 37 CFR 1.17 (processing, including petition fees); and 37 CFR 1.18 (post allowance, including issue fees) *except that*: the undersigned does not authorize charges for invention claims (specified in 1.16(h); (I); and (k)). The undersigned authorizes charges for a 35 USC 371 national stage entry of a PCT international application identified in 37 CFR 1.492(a)-(c) and (h)-(j), but not (d)-(g) (all fees other than invention claims fees).

2. FEES (PAID HEREWITH BY EFS CREDIT CARD SUBMISSION) \$: 969

2501 1.18(a)(1) Utility issue fee \$960

Printed copy of patent w/o color, delivery by USPS, USPTO Box, or electronic means 3.00; 3 at 3.00 per or 9.00 total

3. THE FOLLOWING DOCUMENTS ARE SUBMITTED HEREWITH:

Part B - Fee(s) Transmittal (1 page)

4. FOR INTERNAL NEIFELD IP LAW, PC USE ONLY

Disbursements: BankAcct#6, G/L 5010, check, amount, and entry date: 2271, 969, 6/11/2015

PClaw billing matter: [SCOT0001]

Service Fees: Amount/CreditAtty/entry date/Services:

\$400/BTM/6/11/2015/Firm charge for paying gov. fee.

INITIALS OF PERSON WHO **ENTERED** ACCOUNTING DATA: BTM

ATTORNEY SIGNATURE (AUTHORIZING DEPOSIT ACCOUNT)

DATE: 6/11/2015

SIGNATURE: /BruceMargulies/

PRINTED NAME: BruceMargulies Reg. #64,175

Printed: June 11, 2015 (10:04am)

Y:\Clients\SCOT Scott A Moskowitz and Wistaria Trading,

Inc\SCOT0014-4\Drafts\FilingOfIssueFeeTransmittal_SCOT0014-4_6-11-2015.wpd

Neifeld Docket No: SCOT0014-4

Application/Patent No: 11/895,388

USPTO CONFIRMATION NO: 2103

File/Issue Date: 8/24/2007

Inventor/title: Moskowitz/ Data protection method and device

Examiner/ArtUnit: Izunna OKEKE/2432

ENTITY STATUS: SMALL (CONVERT UPON ALLOWANCE TO LARGE)

Priority: Application No. 09/046,627 (which issued July 22, 2003, as U.S. Patent No. 6,598,162)

ASSISTANT COMMISSIONER FOR PATENTS

ALEXANDRIA, VA 22313

AMENDMENT AFTER ALLOWANCE (37 CFR 1.312)

OK TO ENTER: /I.O./
06/10/2015

Dear Sir or Madam:

In response to the notice of allowance mailed June 4, 2015, the applicant responds as follows:



UNITED STATES PATENT AND TRADEMARK OFFICE

UNITED STATES DEPARTMENT OF COMMERCE
United States Patent and Trademark Office
Address: COMMISSIONER FOR PATENTS
P.O. Box 1450
Alexandria, Virginia 22313-1450
www.uspto.gov

APPLICATION NO.	FILING DATE	FIRST NAMED INVENTOR	ATTORNEY DOCKET NO.	CONFIRMATION NO.
11/895,388	08/24/2007	Scott A. Moskowitz	SCOT0014-4	2103
31518	7590	06/15/2015	EXAMINER	
NEIFELD IP LAW, PC 4813-B EISENHOWER AVENUE ALEXANDRIA, VA 22304			OKEKE, IZUNNA	
			ART UNIT	PAPER NUMBER
			2432	
			NOTIFICATION DATE	DELIVERY MODE
			06/15/2015	ELECTRONIC

Please find below and/or attached an Office communication concerning this application or proceeding.

The time period for reply, if any, is set in the attached communication.

Notice of the Office communication was sent electronically on above-indicated "Notification Date" to the following e-mail address(es):

general@neifeld.com
rneifeld@neifeld.com
rhahl@neifeld.com

Response to Rule 312 Communication	Application No. 11/895,388	Applicant(s) MOSKOWITZ, SCOTT A.
	Examiner IZUNNA OKEKE	Art Unit 2432

-- The MAILING DATE of this communication appears on the cover sheet with the correspondence address --

1. The amendment filed on 05 June 2015 under 37 CFR 1.312 has been considered, and has been:
- a) entered.
 - b) entered as directed to matters of form not affecting the scope of the invention.
 - c) disapproved because the amendment was filed after the payment of the issue fee.
Any amendment filed after the date the issue fee is paid must be accompanied by a petition under 37 CFR 1.313(c)(1) and the required fee to withdraw the application from issue.
 - d) disapproved. See explanation below.
 - e) entered in part. See explanation below.

/IZUNNA OKEKE/
Primary Examiner, Art Unit 2432



UNITED STATES PATENT AND TRADEMARK OFFICE

UNITED STATES DEPARTMENT OF COMMERCE
United States Patent and Trademark Office
Address: COMMISSIONER FOR PATENTS
P.O. Box 1450
Alexandria, Virginia 22313-1450
www.uspto.gov

Table with 7 columns: APPLICATION NUMBER, FILING or 371(c) DATE, GRP ART UNIT, FIL FEE REC'D, ATTY.DOCKET.NO, TOT CLAIMS, IND CLAIMS. Row 1: 11/895,388, 08/24/2007, 2432, 1577, SCOT0014-4, 31, 5

CONFIRMATION NO. 2103
CORRECTED FILING RECEIPT

31518
NEIFELD IP LAW, PC
4813-B EISENHOWER AVENUE
ALEXANDRIA, VA 22304



Date Mailed: 06/15/2015

Receipt is acknowledged of this non-provisional patent application. The application will be taken up for examination in due course. Applicant will be notified as to the results of the examination. Any correspondence concerning the application must include the following identification information: the U.S. APPLICATION NUMBER, FILING DATE, NAME OF APPLICANT, and TITLE OF INVENTION. Fees transmitted by check or draft are subject to collection. Please verify the accuracy of the data presented on this receipt. If an error is noted on this Filing Receipt, please submit a written request for a Filing Receipt Correction. Please provide a copy of this Filing Receipt with the changes noted thereon. If you received a "Notice to File Missing Parts" for this application, please submit any corrections to this Filing Receipt with your reply to the Notice. When the USPTO processes the reply to the Notice, the USPTO will generate another Filing Receipt incorporating the requested corrections

Inventor(s) Scott A. Moskowitz, Sunny Isles Beach, FL;
Applicant(s) Scott A. Moskowitz, Sunny Isles Beach, FL;

Power of Attorney: The patent practitioners associated with Customer Number 31518

Domestic Priority data as claimed by applicant
This application is a DIV of 10/602,777 06/25/2003 PAT 7664263
which is a CON of 09/046,627 03/24/1998 PAT 6598162

Foreign Applications for which priority is claimed (You may be eligible to benefit from the Patent Prosecution Highway program at the USPTO. Please see http://www.uspto.gov for more information.) - None.
Foreign application information must be provided in an Application Data Sheet in order to constitute a claim to foreign priority. See 37 CFR 1.55 and 1.76.

If Required, Foreign Filing License Granted: 09/13/2007

The country code and number of your priority application, to be used for filing abroad under the Paris Convention, is US 11/895,388

Projected Publication Date: Not Applicable

Non-Publication Request: No

Early Publication Request: No

** SMALL ENTITY **

Title

Data protection method and device

Preliminary Class

713

Statement under 37 CFR 1.55 or 1.78 for AIA (First Inventor to File) Transition Applications:

PROTECTING YOUR INVENTION OUTSIDE THE UNITED STATES

Since the rights granted by a U.S. patent extend only throughout the territory of the United States and have no effect in a foreign country, an inventor who wishes patent protection in another country must apply for a patent in a specific country or in regional patent offices. Applicants may wish to consider the filing of an international application under the Patent Cooperation Treaty (PCT). An international (PCT) application generally has the same effect as a regular national patent application in each PCT-member country. The PCT process **simplifies** the filing of patent applications on the same invention in member countries, but **does not result** in a grant of "an international patent" and does not eliminate the need of applicants to file additional documents and fees in countries where patent protection is desired.

Almost every country has its own patent law, and a person desiring a patent in a particular country must make an application for patent in that country in accordance with its particular laws. Since the laws of many countries differ in various respects from the patent law of the United States, applicants are advised to seek guidance from specific foreign countries to ensure that patent rights are not lost prematurely.

Applicants also are advised that in the case of inventions made in the United States, the Director of the USPTO must issue a license before applicants can apply for a patent in a foreign country. The filing of a U.S. patent application serves as a request for a foreign filing license. The application's filing receipt contains further information and guidance as to the status of applicant's license for foreign filing.

Applicants may wish to consult the USPTO booklet, "General Information Concerning Patents" (specifically, the section entitled "Treaties and Foreign Patents") for more information on timeframes and deadlines for filing foreign patent applications. The guide is available either by contacting the USPTO Contact Center at 800-786-9199, or it can be viewed on the USPTO website at <http://www.uspto.gov/web/offices/pac/doc/general/index.html>.

For information on preventing theft of your intellectual property (patents, trademarks and copyrights), you may wish to consult the U.S. Government website, <http://www.stopfakes.gov>. Part of a Department of Commerce initiative, this website includes self-help "toolkits" giving innovators guidance on how to protect intellectual property in specific countries such as China, Korea and Mexico. For questions regarding patent enforcement issues, applicants may call the U.S. Government hotline at 1-866-999-HALT (1-866-999-4258).

**LICENSE FOR FOREIGN FILING UNDER
Title 35, United States Code, Section 184
Title 37, Code of Federal Regulations, 5.11 & 5.15**

GRANTED

The applicant has been granted a license under 35 U.S.C. 184, if the phrase "IF REQUIRED, FOREIGN FILING LICENSE GRANTED" followed by a date appears on this form. Such licenses are issued in all applications where the conditions for issuance of a license have been met, regardless of whether or not a license may be required as set forth in 37 CFR 5.15. The scope and limitations of this license are set forth in 37 CFR 5.15(a) unless an earlier license has been issued under 37 CFR 5.15(b). The license is subject to revocation upon written notification. The date indicated is the effective date of the license, unless an earlier license of similar scope has been granted under 37 CFR 5.13 or 5.14.

This license is to be retained by the licensee and may be used at any time on or after the effective date thereof unless it is revoked. This license is automatically transferred to any related applications(s) filed under 37 CFR 1.53(d). This license is not retroactive.

The grant of a license does not in any way lessen the responsibility of a licensee for the security of the subject matter as imposed by any Government contract or the provisions of existing laws relating to espionage and the national security or the export of technical data. Licensees should apprise themselves of current regulations especially with respect to certain countries, of other agencies, particularly the Office of Defense Trade Controls, Department of State (with respect to Arms, Munitions and Implements of War (22 CFR 121-128)); the Bureau of Industry and Security, Department of Commerce (15 CFR parts 730-774); the Office of Foreign Assets Control, Department of Treasury (31 CFR Parts 500+) and the Department of Energy.

NOT GRANTED

No license under 35 U.S.C. 184 has been granted at this time, if the phrase "IF REQUIRED, FOREIGN FILING LICENSE GRANTED" DOES NOT appear on this form. Applicant may still petition for a license under 37 CFR 5.12, if a license is desired before the expiration of 6 months from the filing date of the application. If 6 months has lapsed from the filing date of this application and the licensee has not received any indication of a secrecy order under 35 U.S.C. 181, the licensee may foreign file the application pursuant to 37 CFR 5.15(b).

SelectUSA

The United States represents the largest, most dynamic marketplace in the world and is an unparalleled location for business investment, innovation, and commercialization of new technologies. The U.S. offers tremendous resources and advantages for those who invest and manufacture goods here. Through SelectUSA, our nation works to promote and facilitate business investment. SelectUSA provides information assistance to the international investor community; serves as an ombudsman for existing and potential investors; advocates on behalf of U.S. cities, states, and regions competing for global investment; and counsels U.S. economic development organizations on investment attraction best practices. To learn more about why the United States is the best country in the world to develop technology, manufacture products, deliver services, and grow your business, visit <http://www.SelectUSA.gov> or call +1-202-482-6800.

PTO/SB/08B (04-07)

Approved for use through 09/30/2007. OMB 0651-0031

U.S. Patent and Trademark Office, U.S. DEPARTMENT OF COMMERCE

Under the Paperwork Reduction Act of 1995, no persons are required to respond to a collection of information unless it contains a valid OMB control number.

Substitute for form 1449/PTO

Complete if Known



INFORMATION DISCLOSURE STATEMENT BY APPLICANT

(Use as many sheets as necessary)

Application Number	11/895,388
Filing Date	August 24, 2007
First Named Inventor	Scott A. MOSKOWITZ
Art Unit	2132
Examiner Name	NA
Attorney Docket Number	80391.0003CONT2

NON PATENT LITERATURE DOCUMENTS			
Examiner Initials*	Cite No. ¹	Include name of the author (in CAPITAL LETTERS), title of the article (when appropriate), title of the item (book, magazine, journal, serial, symposium, catalog, etc.), date, page(s), volume-issue number(s), publisher, city and/or country where published.	T ²
		PCT International Search Report, completed Sept. 13, 1995; authorized officer Huy D. Vu (PCT/US95/08159) (2 pages)	
		PCT International Search Report, completed June 11, 1996; authorized officer Salvatore Cangialosi (PCT/US96/10257) (4 pages)	
		Supplementary European Search Report, completed Mar. 5, 2004; authorized officer J. Hazel (EP 96 91 9405) (1 page)	
		PCT International Search Report, completed April 4, 1997; authorized officer Bernarr Earl Gregory (PCT/US97/00651) (1 page)	
		PCT International Search Report, completed May 6, 1997; authorized officer Salvatore Cangialosi (PCT/US97/00652) (3 pages)	
		PCT International Search Report, completed Oct. 23, 1997; authorized officer David Cain (PCT/US97/11455) (1 page)	
		PCT International Search Report, completed July 12, 1999; authorized officer R. Hubeau (PCT/US99/07262) (3 pages)	
		PCT International Search Report, completed June 30, 2000; authorized officer Paul E. Callahan (PCT/US00/06522) (7 pages)	
		Supplementary European Search Report, completed June 27, 2002; authorized officer M. Schoeyer (EP 00 91 9398) (1 page)	
		PCT International Search Report, date of mailing Mar. 15, 2001; authorized officer Marja Brouwers (PCT/US00/18411) (5 pages)	

Examiner Signature	/Izunna Okeke/	Date Considered	07/08/2015
--------------------	----------------	-----------------	------------

*EXAMINER: Initial if reference considered, whether or not citation is in conformance with MPEP 609. Draw line through citation if not in conformance and not considered. Include copy of this form with next communication to applicant.

¹ Applicant's unique citation designation number (optional). ² Applicant is to place a check mark here if English language Translation is attached.

This collection of information is required by 37 CFR 1.98. The information is required to obtain or retain a benefit by the public which is to file (and by the USPTO to process) an application. Confidentiality is governed by 35 U.S.C. 122 and 37 CFR 1.14. This collection is estimated to take 2 hours to complete, including gathering, preparing, and submitting the completed application form to the USPTO. Time will vary depending upon the individual case. Any comments on the amount of time you require to complete this form and/or suggestions for reducing this burden, should be sent to the Chief Information Officer, U.S. Patent and Trademark Office, P.O. Box 1450, Alexandria, VA 22313-1450. DO NOT SEND FEES OR COMPLETED FORMS TO THIS ADDRESS. SEND TO: Commissioner for Patents, P.O. Box 1450, Alexandria, VA 22313-1450.

If you need assistance in completing the form, call 1-800-PTO-9192 (1-800-786-9199) and select option 2. ALL REFERENCES CONSIDERED EXCEPT WHERE LINED THROUGH. /I.O./

PTO/SB/08B (04-07)

Approved for use through 09/30/2007. OMB 0651-0031
U.S. Patent and Trademark Office; U.S. DEPARTMENT OF COMMERCE

Under the Paperwork Reduction Act of 1995, no persons are required to respond to a collection of information unless it contains a valid OMB control number.

Substitute for form 1449/PTO		Complete if Known	
INFORMATION DISCLOSURE STATEMENT BY APPLICANT <i>(Use as many sheets as necessary)</i>		Application Number	11/895,388
		Filing Date	August 24, 2007
		First Named Inventor	Scott A. MOSKOWITZ
		Art Unit	2132
		Examiner Name	NA
		Examiner Name	80391.0003CONT2
Sheet	2	of	9
		Attorney Docket Number	

NON PATENT LITERATURE DOCUMENTS			
Examiner Initials*	Cite No. ¹	Include name of the author (in CAPITAL LETTERS), title of the article (when appropriate), title of the item (book, magazine, journal, serial, symposium, catalog, etc.), date, page(s), volume-issue number(s), publisher, city and/or country where published.	T ²
		PCT International Search Report, completed July 20, 2001; authorized officer A. Sigolo (PCT/US00/18411) (5 pages)	
		PCT International Search Report, completed March 20, 2001; authorized officer P. Corcoran (PCT/US00/33126) (6 pages)	
		PCT International Search Report, completed January 26, 2001; authorized officer Gilberto Barron (PCT/US00/21189) (3 pages)	

Examiner Signature	/Azunna Okeke/	Date Considered	07/08/2015
--------------------	----------------	-----------------	------------

*EXAMINER: Initial if reference considered, whether or not citation is in conformance with MPEP 609. Draw line through citation if not in conformance and not considered. Include copy of this form with next communication to applicant.
¹ Applicant's unique citation designation number (optional). ² Applicant is to place a check mark here if English language Translation is attached.
 This collection of information is required by 37 CFR 1.98. The information is required to obtain or retain a benefit by the public which is to file (and by the USPTO to process) an application. Confidentiality is governed by 35 U.S.C. 122 and 37 CFR 1.14. This collection is estimated to take 2 hours to complete, including gathering, preparing, and submitting the completed application form to the USPTO. Time will vary depending upon the individual case. Any comments on the amount of time you require to complete this form and/or suggestions for reducing this burden, should be sent to the Chief Information Officer, U.S. Patent and Trademark Office, P.O. Box 1450, Alexandria, VA 22313-1450. DO NOT SEND FEES OR COMPLETED FORMS TO THIS ADDRESS. SEND TO: Commissioner for Patents, P.O. Box 1450, Alexandria, VA 22313-1450.

If you need assistance in completing the form, call 1-800-PTO-9199 (1-800-786-9199) and select option 2.
 ALL REFERENCES CONSIDERED EXCEPT WHERE LINED THROUGH. /I.O./

PTO/SB/08B (09-06)
 Approved for use through 03/31/2007. OMB 0651-0031
 U.S. Patent and Trademark Office; U.S. DEPARTMENT OF COMMERCE

Under the Paperwork Reduction Act of 1995, no persons are required to respond to a collection of information unless it contains a valid OMB control number.

Substitute for form 1449/PTO		Complete if Known	
INFORMATION DISCLOSURE STATEMENT BY APPLICANT (Use as many sheets as necessary)		Application Number	11/895,388
		Filing Date	August 24, 2007
		First Named Inventor	Scott A. MOSKOWITZ
		Art Unit	2132
		Examiner Name	NA
		Attorney Docket Number	80391.0003CONT2
Sheet	3	of	9

NON PATENT LITERATURE DOCUMENTS			
Examiner Initials*	Cite No. ¹	Include name of the author (in CAPITAL LETTERS), title of the article (when appropriate), title of the item (book, magazine, journal, serial, symposium, catalog, etc.), date, page(s), volume-issue number(s), publisher, city and/or country where published.	T ²
		Schneier, Bruce, Applied Cryptography, 2nd Ed., John Wiley & Sons, pp. 9-10, 1996	
		Menezes, Alfred J., Handbook of Applied Cryptography, CRC Press, p. 46, 1997	
		Merriam-Webster's Collegiate Dictionary, 10th Ed., Merriam Webster, Inc., p.207	
		Brealy, et al., Principles of Corporate Finance, "Appendix A-Using Option Valuation Models", 1984, pp. 448-449	
		Copeland, et al., Real Options:A Practioner's Guide, 2001 pp. 106-107, 201-202, 204-208.	
		Sarkar, M. "An Assessment of Pricing Mechanisms for the Internet-A Regulatory Imperative", presented MIT Workshop on Internet Economics, Mar. 1995 http://www.press.umich.edu/ien/works/SarkAsses.html on	
		Crawford, D.W. "Pricing Network Usage:A Market for Bandwidth of Market Communication?" presented MIT Workshop on Internet Economics, Mar. 1995 http://www.press.umich.edu/ien/works/CrawMarket.html on March	
		LOW, S.H., "Equilibrium Allocation and Pricing of Variable Resources Among User-Suppliers", 1988. http://www.citesear.nj.nec.com/366503.html	
		Caronni, Germano, "Assuring Ownership Rights for Digital Images", published proceeds of reliable IT systems, v15 '95, H.H. Bruggemann and W. Gerhardt-Hackel (Ed.) Viewing Publishing Company, Germany, 1995	
		Zhao, Jian. "A WWW Service to Embed and Prove Digital Copyright Watermarks", Proc. of the european conf. on Multimedia Applications, Services & Techniques Louvain-La-Neuve, Belgium, May 1996	

Examiner Signature	/zunna Okeke/	Date Considered	07/08/2015
--------------------	---------------	-----------------	------------

*EXAMINER: Initial if reference considered, whether or not citation is in conformance with MPEP 609. Draw line through citation if not in conformance and not considered. Include copy of this form with next communication to applicant.
 1 Applicant's unique citation designation number (optional). 2 Applicant is to place a check mark here if English language Translation is attached.
 This collection of information is required by 37 CFR 1.98. The information is required to obtain or retain a benefit by the public which is to file (and by the USPTO to process) an application. Confidentiality is governed by 35 U.S.C. 122 and 37 CFR 1.14. This collection is estimated to take 2 hours to complete, including gathering, preparing, and submitting the completed application form to the USPTO. Time will vary depending upon the individual case. Any comments on the amount of time you require to complete this form and/or suggestions for reducing this burden, should be sent to the Chief Information Officer, U.S. Patent and Trademark Office, P.O. Box 1450, Alexandria, VA 22313-1450. DO NOT SEND FEES OR COMPLETED FORMS TO THIS ADDRESS. SEND TO: Commissioner for Patents, P.O. Box 1450, Alexandria, VA 22313-1450.

If you need assistance in completing the form, call 1-800-PTO-9199 (1-800-786-9199) and select option 2.
 ALL REFERENCES CONSIDERED EXCEPT WHERE LINED THROUGH. /I.O./

PTO/SB/08B (09-06)
 Approved for use through 03/31/2007. OMB 0651-0031
 U.S. Patent and Trademark Office; U.S. DEPARTMENT OF COMMERCE

Under the Paperwork Reduction Act of 1995, no persons are required to respond to a collection of information unless it contains a valid OMB control number.

Substitute for form 1449/PTO INFORMATION DISCLOSURE STATEMENT BY APPLICANT (Use as many sheets as necessary)		Complete if Known	
		Application Number	11/895,388
		Filing Date	August 24, 2007
		First Named Inventor	Scott A. MOSKOWITZ
		Art Unit	2132
		Examiner Name	NA
Sheet <u>4</u>	of <u>9</u>	Attorney Docket Number	80391.0003CONT2

NON PATENT LITERATURE DOCUMENTS			
Examiner Initials*	Cite No. ¹	Include name of the author (in CAPITAL LETTERS), title of the article (when appropriate), title of the item (book, magazine, journal, serial, symposium, catalog, etc.), date, page(s), volume-issue number(s), publisher, city and/or country where published.	T ²
		Gruhl, Daniel et al., Echo Hiding. In Proceeding of the Workshop on Information Hiding. No. 1174 in Lecture Notes in Computer Science, Cambridge, England (May/June 1996)	
		Oomen, A.W.J. et al., A Variable Bit Rate Buried Data Channel for Compact Disc, J.Audio Eng.Sc., Vol.43, No.1/2, pp. 23-28 (1995).	
		Ten Kate, W. et al., A New Surround-Stereo-Surround Coding Techniques, J. Audio Eng.Soc., Vol. 40, No. 5, pp. 376-383 (1992)	
		Gerzon, Michael et al., A High Rate Buried Data Channel for Audio CD, presentation notes, Audio Engineering Soc. 94th Convention (1993).	
		Sklar, Bernard, Digital Communications, pp. 601-603 (1988)	
		Jayant, N.S. et al., Digital Coding of Waveforms, Prentice Hall Inc., Englewood Cliffs, NJ, pp. 486-509 (1984)	
		Bender, Walter R. et al., Techniques for Data Hiding, SPIE Int. Soc. Opt. Eng., Vol. 2420, pp. 164-173, 1995.	
		Zhao, Jian et al., Embedding Robust Labels into Images for Copyright Protection, (xp 000571976), pp. 242-251, 1995.	
		Menezes, Alfred J., Handbook of Applied Cryptography, CRC Press, p. 175, 1997.	
		Schneier, Bruce, Applied Cryptography, 1st Ed., pp. 67-68, 1994.	

Examiner Signature	/Azunna Okeke/	Date Considered	07/08/2015
--------------------	----------------	-----------------	------------

*EXAMINER: Initial if reference considered, whether or not citation is in conformance with MPEP 609. Draw line through citation if not in conformance and not considered. Include copy of this form with next communication to applicant.

¹ Applicant's unique citation designation number (optional). ² Applicant is to place a check mark here if English language Translation is attached. This collection of information is required by 37 CFR 1.98. The information is required to obtain or retain a benefit by the public which is to file (and by the USPTO to process) an application. Confidentiality is governed by 35 U.S.C. 122 and 37 CFR 1.14. This collection is estimated to take 2 hours to complete, including gathering, preparing, and submitting the completed application form to the USPTO. Time will vary depending upon the individual case. Any comments on the amount of time you require to complete this form and/or suggestions for reducing this burden, should be sent to the Chief Information Officer, U.S. Patent and Trademark Office, P.O. Box 1450, Alexandria, VA 22313-1450. DO NOT SEND FEES OR COMPLETED FORMS TO THIS ADDRESS. SEND TO: Commissioner for Patents, P.O. Box 1450, Alexandria, VA 22313-1450.

If you need assistance in completing the form, call 1-800-PTO-9199 (1-800-786-9199) and select option 2.

ALL REFERENCES CONSIDERED EXCEPT WHERE LINED THROUGH. /I.O./

Under the Paperwork Reduction Act of 1995, no persons are required to respond to a collection of information unless it contains a valid OMB control number.

Substitute for form 1449/PTO		Complete if Known	
INFORMATION DISCLOSURE STATEMENT BY APPLICANT <i>(Use as many sheets as necessary)</i>		Application Number	11/895,388
		Filing Date	August 24, 2007
		First Named Inventor	Scott A. MOSKOWITZ
		Art Unit	2132
		Examiner Name	NA
		Attorney Docket Number	80391.0003CONT2
Sheet	5	of	9

NON PATENT LITERATURE DOCUMENTS			
Examiner Initials*	Cite No. ¹	Include name of the author (in CAPITAL LETTERS), title of the article (when appropriate), title of the item (book, magazine, journal, serial, symposium, catalog, etc.), date, page(s), volume-issue number(s), publisher, city and/or country where published.	T ²
		ten Kate, W. et al., "Digital Audio Carrying Extra Information", IEEE, CH 2847-2/90/0000-1097, (1990)	
		van Schyndel, et al. A digital Watermark, IEEE Int'l Computer Processing Conference, Austin, TX, Nov 13-16, 1994, pp. 86-90	
		Smith, et al. Modulation and Information Hiding in Images, Springer Verlag, 1st Int'l Workshop, Cambridge, UK, May 30-June 1, 1996, pp. 207-227	
		Kutter, Martin et al., Digital Signature of Color Images Using Amplitude Modulation, SPIE-E197, vol. 3022, pp. 518-527	
		Puate, Joan et al., Using Fractal Compression Scheme to Embed a Digital Signature into an Image, SPIE-96 Proceedings, vol. 2915, Mar. 1997, pp. 108-118.	
		Swanson, Mitchell D., et al., Transparent Robust Image Watermarking, Proc. of the 1996 IEEE Int'l Conf. on Image Processing, Vol. 111, 1996, pp. 211-214	
		Swanson, Mitchell D., et al. Robust Data Hiding for Images, 7th IEEE Digital Signal Processing Workshop, Leon, Norway. Sept. 1-4, 1996, pp. 37-40	
		Zhao, Jian et al., Embedding Robust Labels into Images for Copyright Protection, Proceeding of the Know Right '95 Conference, pp. 242-251.	
		Koch, E. et al. Towards Robust and Hidden Image Copyright Labeling, 1995 IEEE Workshop on Nonlinear Signal and Image Processing, Jun. 1995, Neos Marmaras, pp. 4	
		Van Schyndel, et al., Towards a Robust Digital Watermark, Second Asian Image Processing Conference, Dec. 6-8, 1995, Singapore, Vol. 2, pp. 504-508	

Examiner Signature	/Izunna Okeke/	Date Considered	07/08/2015
--------------------	----------------	-----------------	------------

*EXAMINER: Initial if reference considered, whether or not citation is in conformance with MPEP 609. Draw line through citation if not in conformance and not considered. Include copy of this form with next communication to applicant.

¹ Applicant's unique citation designation number (optional). ² Applicant is to place a check mark here if English language Translation is attached. This collection of information is required by 37 CFR 1.98. The information is required to obtain or retain a benefit by the public which is to file (and by the USPTO to process) an application. Confidentiality is governed by 35 U.S.C. 122 and 37 CFR 1.14. This collection is estimated to take 2 hours to complete, including gathering, preparing, and submitting the completed application form to the USPTO. Time will vary depending upon the individual case. Any comments on the amount of time you require to complete this form and/or suggestions for reducing this burden, should be sent to the Chief Information Officer, U.S. Patent and Trademark Office, P.O. Box 1450, Alexandria, VA 22313-1450. DO NOT SEND FEES OR COMPLETED FORMS TO THIS ADDRESS. SEND TO: Commissioner for Patents, P.O. Box 1450, Alexandria, VA 22313-1450.

If you need assistance in completing the form, call 1-800-PTO-9199 (1-800-786-9199) and select option 2.

ALL REFERENCES CONSIDERED EXCEPT WHERE LINED THROUGH. /I.O./

Under the Paperwork Reduction Act of 1995, no persons are required to respond to a collection of information unless it contains a valid OMB control number.

Substitute for form 1449/PTO		Complete if Known	
		Application Number	11/895,388
INFORMATION DISCLOSURE STATEMENT BY APPLICANT (Use as many sheets as necessary)		Filing Date	August 24, 2007
		First Named Inventor	Scott A. MOSKOWITZ
		Art Unit	2132
		Examiner Name	NA
		Attorney Docket Number	80391.0003CONT2
		Sheet	6

NON PATENT LITERATURE DOCUMENTS			
Examiner Initials*	Cite No. ¹	Include name of the author (in CAPITAL LETTERS), title of the article (when appropriate), title of the item (book, magazine, journal, serial, symposium, catalog, etc.), date, page(s), volume-issue number(s), publisher, city and/or country where published.	T ²
		Tirkel, A.Z., A Two-Dimensional Digital Watermark, DICTA '95, Univ. of Queensland, Brisbane, Dec. 5-8, 1995, pp. 7	
		Tirkel, A.Z., Image Watermarking-A Spread Spectrum Application, ISSSTA '96, Sept. 96, Mainz, German, pp. 6.	
		O'Ruanaidh, et al. Watermarking Digital Images for Copyright Protection, IEEE Proceedings, Vol. 143, No. 4, Aug. 96, pp. 250-256.	
		Cox, et al., Secure Spread Spectrum Watermarking for Multimedia, NEC Research Institute, Techinal Report 95-10, pp. 33	
		Kahn, D., The Code Breakers, The MacMillan Company, 1969, pp. xiii, 81-83, 513, 515, 522-526, 863.	
		Boney, et al., Digital Watermarks for Audio Signals, EVSIPCO, 96, pp. 473-480.	
		Dept. of Electrical Engineering, Del Ft University of Technology, Del ft The Netherlands, G.C. Langelaar et al., Copy Protection for Multimedia Data based on Labeling Techniques, July 1996, 9 pp.	
		F. Hartung, et al., Digital Watermarking of Raw and Compressed Video, SPIE Vol. 2952, pp. 205-213.	
		Craver, et al., Can Invisible Watermarks Resolve Rightful Ownerships? IBM Research Report, RC 20509 (July 25, 1996) 21 pp.	
		Press, et al., Numerical Recipes In C, Cambridge Univ. Press, 1988, pp. 398-417.	

Examiner Signature	/Izunna Okeke/	Date Considered	07/08/2015
---------------------------	----------------	------------------------	------------

*EXAMINER: Initial if reference considered, whether or not citation is in conformance with MPEP 609. Draw line through citation if not in conformance and not considered. Include copy of this form with next communication to applicant.
 1 Applicant's unique citation designation number (optional). 2 Applicant is to place a check mark here if English language Translation is attached.
 This collection of information is required by 37 CFR 1.98. The information is required to obtain or retain a benefit by the public which is to file (and by the USPTO to process) an application. Confidentiality is governed by 35 U.S.C. 122 and 37 CFR 1.14. This collection is estimated to take 2 hours to complete, including gathering, preparing, and submitting the completed application form to the USPTO. Time will vary depending upon the individual case. Any comments on the amount of time you require to complete this form and/or suggestions for reducing this burden, should be sent to the Chief Information Officer, U.S. Patent and Trademark Office, P.O. Box 1450, Alexandria, VA 22313-1450. DO NOT SEND FEES OR COMPLETED FORMS TO THIS ADDRESS. SEND TO: Commissioner for Patents, P.O. Box 1450, Alexandria, VA 22313-1450.

If you need assistance in completing the form, call 1-800-PTO-9199 (1-800-786-9199) and select option 2.
 ALL REFERENCES CONSIDERED EXCEPT WHERE LINED THROUGH. /I.O./

PTO/SB/08B (09-06)

Approved for use through 03/31/2007. OMB 0651-0031

U.S. Patent and Trademark Office; U.S. DEPARTMENT OF COMMERCE

Under the Paperwork Reduction Act of 1995, no persons are required to respond to a collection of information unless it contains a valid OMB control number.

Substitute for form 1449/PTO		Complete if Known	
INFORMATION DISCLOSURE STATEMENT BY APPLICANT <i>(Use as many sheets as necessary)</i>		Application Number	11/895,388
		Filing Date	August 24, 2007
		First Named Inventor	Scott A. MOSKOWITZ
		Art Unit	2132
		Examiner Name	NA
		Attorney Docket Number	80391.0003CONT2
Sheet	7	of	9

NON PATENT LITERATURE DOCUMENTS			
Examiner Initials*	Cite No. ¹	Include name of the author (in CAPITAL LETTERS), title of the article (when appropriate), title of the item (book, magazine, journal, serial, symposium, catalog, etc.), date, page(s), volume-issue number(s), publisher, city and/or country where published.	T ²
		Pohlmann, Ken C., Principles of Digital Audio, 3rd Ed., 1995, pp. 32-37, 40-48, 138, 147-149, 332, 333, 364, 499-501, 508-509, 564-571.	
		Pohlmann, Ken C., Principles of Digital Audio, 2nd Ed., 1991, pp. 1-9, 19-25, 30-33, 41-48, 54-57, 86-107, 375-387.	
		Schneier, Bruce, Applied Cryptography, John Wiley & Sons, inc., New York, 1994, pp. 68, 69, 387-392, 1-57, 273-275, 321-324.	
		Boney, et al., Digital Watermarks for Audio Signals, Proceedings of the International Conf. on Multimedia Computing and Systems, June 17-23, 1996, Hiroshima, Japan. 0-8186-7436-9/96, pp. 473-480.	
		Johnson, et al., Transform Permuted Watermarking for Copyright Protection of Digital Video, IEEE Globecom 1998, Nov 8-12, 1998, New York, New York. Vol. 2, 1998, pp. 684-689 (ISBN 0-7803-4985-7)	
		Rivest, et al., "Pay Word and Micromint: Two Simple Micropayment Schemes," MIT Laboratory for Computer Science, Cambridge, MA, May 7, 1996, pp. 1-18.	
		Bender, et al., Techniques for Data Hiding, IBM Systems Journal, Vol. 35, Nos 3 & 4, 1996, pp. 313-336.	
		Moskowitz, Bandwith as Currency, IEEE Multimedia, Jan-Mar 2003, pp. 14-21.	
		Moskowitz, Multimedia Security Technologies for Digital Rights Management, 2006, Academic Press, "Introduction-Digital Rights Management" pp. 3-22	

Examiner Signature	/Izunna Okeke/	Date Considered	07/08/2015
--------------------	----------------	-----------------	------------

*EXAMINER: Initial if reference considered, whether or not citation is in conformance with MPEP 609. Draw line through citation if not in conformance and not considered. Include copy of this form with next communication to applicant.

¹ Applicant's unique citation designation number (optional). ² Applicant is to place a check mark here if English language Translation is attached. This collection of information is required by 37 CFR 1.98. The information is required to obtain or retain a benefit by the public which is to file (and by the USPTO to process) an application. Confidentiality is governed by 35 U.S.C. 122 and 37 CFR 1.14. This collection is estimated to take 2 hours to complete, including gathering, preparing, and submitting the completed application form to the USPTO. Time will vary depending upon the individual case. Any comments on the amount of time you require to complete this form and/or suggestions for reducing this burden, should be sent to the Chief Information Officer, U.S. Patent and Trademark Office, P.O. Box 1450, Alexandria, VA 22313-1450. DO NOT SEND FEES OR COMPLETED FORMS TO THIS ADDRESS. SEND TO: Commissioner for Patents, P.O. Box 1450, Alexandria, VA 22313-1450.

If you need assistance in completing the form, call 1-800-PTO-9199 (1-800-786-9199), and select option 2. ALL REFERENCES CONSIDERED EXCEPT WHERE LINED THROUGH. /I.O./

PTO/SB/08B (09-06)
 Approved for use through 03/31/2007. OMB 0651-0031
 U.S. Patent and Trademark Office; U.S. DEPARTMENT OF COMMERCE

Under the Paperwork Reduction Act of 1995, no persons are required to respond to a collection of information unless it contains a valid OMB control number.

Substitute for form 1449/PTO		Complete if Known	
INFORMATION DISCLOSURE STATEMENT BY APPLICANT (Use as many sheets as necessary)		Application Number	
		Filing Date	11/895,388
		First Named Inventor	August 24, 2007
		Art Unit	Scott A. MOSKOWITZ
		Examiner Name	2132
		Attorney Docket Number	NA
Sheet	8	of	9
			80391.0003CONT2

NON PATENT LITERATURE DOCUMENTS			
Examiner Initials*	Cite No. ¹	Include name of the author (in CAPITAL LETTERS), title of the article (when appropriate), title of the item (book, magazine, journal, serial, symposium, catalog, etc.), date, page(s), volume-issue number(s), publisher, city and/or country where published.	T ²
		Tomsich, et al., "Towards a secure and de-centralized digital watermarking infrastructure for the protection of Intellectual Property", in <i>Electronic Commerce and Web Technologies, Proceedings (ECWEB)</i>	
		Moskowitz, "What is Acceptable Quality in the Application of Digital Watermarking: Trade-offs of Security, Robustness and Quality", <i>IEEE Computer Society Proceedings of ITCC 2002 April 10 2002 pp 80-84</i>	
		Lemma, et al. "Secure Watermark Embedding through Partial Encryption", <i>International Workshop on Digital Watermarking ("IWDW" 2006), Springer Lecture Notes in Computer Science, 2006. (to appear) 13</i>	
		Kocher, et al., "Self Protecting Digital Content", Technical Report from the <i>ORI Content Security Research Initiative, Cryptography Research, Inc. 2002-2003. 14 pages.</i>	
		Sirbu, M. et al., "Net Bill: An Internet Commerce System Optimized for Network Delivered Services", <i>Digest of Papers of the Computer Society Computer Conference (Spring) 5 March 1995 pp 20-25 vol. CONF40.</i>	
		Schunter, M. et al., "A Status Report on the SEMPER framework for Secure Electronic Commerce", <i>Computer Networks and ISDN Systems, 30 Sept 1998 pp 1501-1510 Vol 30 No 16-18 NL North Holland</i>	
		Konrad, K. et al., "Trust and Electronic Commerce-more than a technical problem," <i>Proceedings of the 18th IEEE Symposium on Reliable Distributed Systems 19-22 October 1999 pp 360-365 Lausanne</i>	
		Kini, a. et al., "Trust in Electronic Commerce: Definition and Theoretical Considerations", <i>Proceedings of the 31st Hawaii Intl Conf on System Sciences (Cat. No. 98TB100216). 6-9 January 1998 pp 51-61. Los</i>	
		Steinauer D. D., et al., "Trust and Traceability in Electronic Commerce", <i>Standard View, Sept 1997, pp 118-124, vol. 5 No. 3, ACM, USA</i>	
		Hartung, et al. "Multimedia Watermarking Techniques", <i>Proceedings of the IEEE, Special Issue, Identification & Protection of Multimedia Information, pp 1079-1107, July 1999 Vol 87 No 7 IEEE</i>	

Examiner Signature	/Izunna Okeke/	Date Considered	07/08/2015
--------------------	----------------	-----------------	------------

*EXAMINER: Initial if reference considered, whether or not citation is in conformance with MPEP 609. Draw line through citation if not in conformance and not considered. Include copy of this form with next communication to applicant.
¹ Applicant's unique citation designation number (optional). ² Applicant is to place a check mark here if English language Translation is attached.
 This collection of information is required by 37 CFR 1.98. The information is required to obtain or retain a benefit by the public which is to file (and by the USPTO to process) an application. Confidentiality is governed by 35 U.S.C. 122 and 37 CFR 1.14. This collection is estimated to take 2 hours to complete, including gathering, preparing, and submitting the completed application form to the USPTO. Time will vary depending upon the individual case. Any comments on the amount of time you require to complete this form and/or suggestions for reducing this burden, should be sent to the Chief Information Officer, U.S. Patent and Trademark Office, P.O. Box 1450, Alexandria, VA 22313-1450. DO NOT SEND FEES OR COMPLETED FORMS TO THIS ADDRESS. SEND TO: Commissioner for Patents, P.O. Box 1450, Alexandria, VA 22313-1450.

If you need assistance in completing the form, call 1-800-PTO-9199 (1-800-786-9199), and select option 2.
 ALL REFERENCES CONSIDERED EXCEPT WHERE LINED THROUGH. /I.O./

PTO/SB/08B (10-07)
 Approved for use through 10/31/2007. OMB 0651-0031
 U.S. Patent and Trademark Office; U.S. DEPARTMENT OF COMMERCE

Under the Paperwork Reduction Act of 1995, no persons are required to respond to a collection of information unless it contains a valid OMB control number.

Substitute for form 1449/PTO		Complete if Known	
INFORMATION DISCLOSURE STATEMENT BY APPLICANT (Use as many sheets as necessary)		Application Number	11/895,388
		Filing Date	August 24, 2007
		First Named Inventor	Scott A. MOSKOWITZ
		Art Unit	2132
		Examiner Name	NA
		Attorney Docket Number	80391.0003CONT2
Sheet	9	of	9

NON PATENT LITERATURE DOCUMENTS			
Examiner Initials*	Cite No. ¹	Include name of the author (in CAPITAL LETTERS), title of the article (when appropriate), title of the item (book, magazine, journal, serial, symposium, catalog, etc.), date, page(s), volume-issue number(s), publisher, city and/or country where published.	T ²
		Rivest, et al., PayWord and MicroMint: Two simple micropayment schemes, MIT Laboratory for Computer Science, Cambridge, MA 02139, April 27, 2001, pp. 1-18.	
		Horowitz, et al., The Art of Electronics, 2nd Ed., 1989, pp.7.	
		Delaigle, J.-F., et al. "Digital Watermarking," Proceedings of the SPIE, vol. 2659, Feb 1, 1996, pp. 99-110 (Abstract).	
		Schneider, M., et al. "Robust Content Based Digital Signature for Image Authentication," Proceedings of the International Conference on Image Processing (IC. Lausanne) Sept. 16-19, 1996, pp. 227-230. IEEE ISBN:	
		Cox, I. J., et al. "Secure Spread Spectrum Watermarking for Multimedia," IEEE Transactions on Image Processing, Vol. 6 No. 12, Dec. 1, 1997, pp. 1673-1686.	
		Wong, Ping Wah. "A Public Key Watermark for Image Verification and Authentication," IEEE International Conference on Image Processing, Vol. 1 Oct 4-7 1998, pp. 455-459.	
		Fabien A.P. Petitcolas, Ross J. Anderson and Markkus G. Kuhn, "Attacks on Copyright Marking Systems," LNCS, Vol. 1525, April 14-17, 1998, pp. 218-238. ISBN: 3-540-65386-4	
		Ross Anderson, "Stretching the Limits of Steganography," LNCS, Vol. 1174, May/June 1996, 10 pages, ISBN: 3-540-61996-8.	
		Joseph J.K. O'Ruanaidh and Thierry Pun. "Rotation, Scale and Translation Invariant Digital Image Watermarking", pre-publication, Summer 1997, 4 pages.	
		Joseph J.K. O'Ruanaidh and Thierry Pun, "Rotation, Scale and Translation Invariant Digital Image Watermarking", Submitted to Signal Processing, August 21, 1997, 19 pages.	

Examiner Signature	/Izunna Okeke/	Date Considered	07/08/2015
--------------------	----------------	-----------------	------------

*EXAMINER: Initial if reference considered, whether or not citation is in conformance with MPEP 609. Draw line through citation if not in conformance and not considered. Include copy of this form with next communication to applicant.
 1 Applicant's unique citation designation number (optional). 2 Applicant is to place a check mark here if English language Translation is attached.
 This collection of information is required by 37 CFR 1.98. The information is required to obtain or retain a benefit by the public which is to file (and by the USPTO to process) an application. Confidentiality is governed by 35 U.S.C. 122 and 37 CFR 1.14. This collection is estimated to take 2 hours to complete, including gathering, preparing, and submitting the completed application form to the USPTO. Time will vary depending upon the individual case. Any comments on the amount of time you require to complete this form and/or suggestions for reducing this burden, should be sent to the Chief Information Officer, U.S. Patent and Trademark Office, P.O. Box 1450, Alexandria, VA 22313-1450. DO NOT SEND FEES OR COMPLETED FORMS TO THIS ADDRESS. SEND TO: Commissioner for Patents, P.O. Box 1450, Alexandria, VA 22313-1450.

If you need assistance in completing the form, call 1-800-PTO-9199 (1-800-786-9199) and select option 2.

ALL REFERENCES CONSIDERED EXCEPT WHERE LINED THROUGH. /I.O./

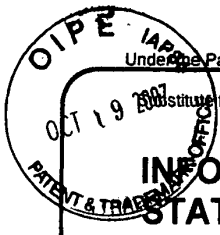

Under the Paperwork Reduction Act of 1995, no persons are required to respond to a collection of information unless it contains a valid OMB control number.

PTO/SB/08A (09-06)

Approved for use through 03/31/2007. OMB 0651-0031
U.S. Patent and Trademark Office; U.S. DEPARTMENT OF COMMERCE

Substitute for form 1449/PTO

INFORMATION DISCLOSURE STATEMENT BY APPLICANT

(Use as many sheets as necessary)

Sheet 1 of 12

Application Number		11/895,388
Filing Date		August 24, 2007
First Named Inventor		Scott A. MOSKOWITZ
Art Unit		2132
Examiner Name		NA
Attorney Docket Numb		80391.0003CONT2

Complete if Known

U. S. PATENT DOCUMENTS					
Examiner Initials*	Cite No. ¹	Document Number	Publication Date	Name of Patentee or Applicant of Cited Document	Pages, Columns, Lines, Where Relevant Passages or Relevant Figures Appear
		Number-Kind Code ² (if known)	MM-DD-YYYY		
		US-4,939,515	07/03/1990	Adelson	
		US-5,161,210	11/03/1992	Druyvesteyn, et. al.	
		US-5,450,490	09/12/1995	Jensen et. al.	
		US-5,530,751	06/25/1996	Morris	
		US-5,579,124	11/26/1996	Aijala et. al.	
		US-5,721,788	02/24/1998	Powell et. al.	
		US-5,828,325	10/27/1998	Wolose Wicz et. al.	
		US-5,912,972	06/15/1999	Barton	
		US-5,930,377	07/27/1999	Powell et. al.	
		US-5,583,488	12/10/1996	Sala et. al.	
		US-5,748,783	05/05/1998	Rhoads	
		US-6,330,672	12/11/2001	Shur	
		US-5,243,423	09/07/1993	DeJean et. al.	
		US-5,319,735	06/07/1994	Preuss et. al.	
		US-5,113,437	05/12/1992	Best et. al.	
		US-4,876,617	10/24/1989	Best et. al.	
		US-5,379,345	01/03/1995	Greenberg	
		US-5,646,997	07/08/1997	Barton	
		US-4,672,605	06/09/1987	Hustig et. al.	

FOREIGN PATENT DOCUMENTS						
Examiner Initials*	Cite No. ¹	Foreign Patent Document	Publication Date	Name of Patentee or Applicant of Cited Document	Pages, Columns, Lines, Where Relevant Passages Or Relevant Figures Appear	T ⁶
		Country Code ³ Number ⁴ Kind Code ⁵ (if known)	MM-DD-YYYY			
		European Patent No. EP0565947A1	10/20/1993	Kuusama, Juha		
		WO 95/14289	05/26/1995	Rhoads, Geoffrey		
		European Patent No. 0581317A2	02/02/1994	Powell, Robert et. al.		
		European Patent No. 0372601A1	06/13/1990	Druyvesteyn, Wm. et. al.		
		W098/37513	08/27/1998	Biggar, Michael et. al.		
		European Patent No. 0651554A	05/03/1995	Eastman Kodak Co.		

Examiner Signature	/Izunna Okeke/	Date Considered	07/08/2015
--------------------	----------------	-----------------	------------

¹EXAMINER: Initial if reference considered, whether or not citation is in conformance with MPEP 609. Draw line through citation if not in conformance and not considered. Include copy of this form with next communication to applicant. ² Applicant's unique citation designation number (optional). ³ See Kinds Codes of USPTO Patent Documents at www.uspto.gov or MPEP 901.04. ⁴ Enter Office that issued the document, by the two-letter code (WIPO Standard ST.3). ⁵ For Japanese patent documents, the indication of the year of the reign of the Emperor must precede the serial number of the patent document. ⁶ Kind of document by the appropriate symbols as indicated on the document under WIPO Standard ST.16 if possible. ⁷ Applicant is to place a check mark here if English language Translation is attached.

This collection of information is required by 37 CFR 1.97 and 1.98. The information is required to obtain or retain a benefit by the public which is to file (and by the USPTO to process) an application. Confidentiality is governed by 35 U.S.C. 122 and 37 CFR 1.14. This collection is estimated to take 2 hours to complete, including gathering, preparing, and submitting the completed application form to the USPTO. Time will vary depending upon the individual case. Any comments on the amount of time you require to complete this form and/or suggestions for reducing this burden, should be sent to the Chief Information Officer, U.S. Patent and Trademark Office, P.O. Box 1450, Alexandria, VA 22313-1450. DO NOT SEND FEES OR COMPLETED FORMS TO THIS ADDRESS. SEND TO: Commissioner for Patents, P.O. Box 1450, Alexandria, VA 22313-1450.

If you need assistance in completing the form, call 1-800-PTO-9199 (1-800-786-9199) and select option 2.

ALL REFERENCES CONSIDERED EXCEPT WHERE LINED THROUGH. /I.O./

PTO/SB/08A (09-06)

Approved for use through 03/31/2007. OMB 0651-0031
U.S. Patent and Trademark Office; U.S. DEPARTMENT OF COMMERCE

Under the Paperwork Reduction Act of 1995, no persons are required to respond to a collection of information unless it contains a valid OMB control number.

Substitute for form 1449/PTO <h2 style="text-align: center;">INFORMATION DISCLOSURE STATEMENT BY APPLICANT</h2> <p style="text-align: center;">(Use as many sheets as necessary)</p>		Complete if Known Application Number Filing Date First Named Inventor Art Unit Examiner Name Attorney Docket Number	
		11/895,388 August 24, 2007 Scott A. MOSKOWITZ 2132 NA 80391.0003CONT2	
Sheet	2	of	12

U. S. PATENT DOCUMENTS					
Examiner Initials*	Cite No. ¹	Document Number	Publication Date MM-DD-YYYY	Name of Patentee or Applicant of Cited Document	Pages, Columns, Lines, Where Relevant Passages or Relevant Figures Appear
		Number-Kind Code ² (if known)			
		US-4,748,668	05/31/1998	Shamir, et.al.	
		US-4,789,928	12/06/1988	Fujisaki	
		US-4,908,873	03/13/1990	Philibert, et.al.	
		US-4,980,782	12/25/1990	Ginkel	
		US-5,073,925	12/17/1991	Nagata, et.al.	
		US-5,243,515	09/07/1993	Lee	
		US-5,287,407	02/15/1994	Holmes	
		US-5,428,606	06/27/1995	Moskowitz	
		US-5,365,586	11/15/1994	Indeck, et.al.	
		US-5,394,324	02/28/1995	Clearwater	
		US-5,408,505	04/18/1995	Indeck, et.al.	
		US-5,412,718	05/02/1995	Narasimhalv, et.al	
		US-5,487,168	01/23/1996	Geiner, et.al.	
		US-5,493,677	02/20/1996	Balogh, et.al	
		US-5,530,759	06/25/1996	Braudaway, et.al	
		US-5,606,609	02/25/1997	Houser, et.al.	
		US-5,613,004	03/18/1997	Cooperman, et.al.	
		US-5,617,119	04/01/1997	Briggs, et.al	
		US-			

FOREIGN PATENT DOCUMENTS						
Examiner Initials*	Cite No. ¹	Foreign Patent Document	Publication Date MM-DD-YYYY	Name of Patentee or Applicant of Cited Document	Pages, Columns, Lines, Where Relevant Passages Or Relevant Figures Appear	T ⁶
		Country Code ³ Number ⁴ Kind Code ⁵ (if known)				
		WO 99/62044	12/02/1999	Handel, Theodore et.al		
		WIPO 96/29795	09/26/1996	Micali		
		WIPO 97/24833	07/10/1997	Micali		
		EP 0649261	04/19/1995	Enari		
		NL 100523	09/1998			

Examiner Signature	/Izunna Okeke/	Date Considered	07/08/2015
--------------------	----------------	-----------------	------------

¹EXAMINER: Initial if reference considered, whether or not citation is in conformance with MPEP 609. Draw line through citation if not in conformance and not considered. Include copy of this form with next communication to applicant. ²Applicant's unique citation designation number (optional). ³See Kinds Codes of USPTO Patent Documents at www.uspto.gov or MPEP 901.04. ⁴Enter Office that issued the document, by the two-letter code (WIPO Standard ST.3). ⁵For Japanese patent documents, the indication of the year of the reign of the Emperor must precede the serial number of the patent document. ⁶Kind of document by the appropriate symbols as indicated on the document under WIPO Standard ST.16 if possible. ⁷Applicant is to place a check mark here if English language Translation is attached.

This collection of information is required by 37 CFR 1.97 and 1.98. The information is required to obtain or retain a benefit by the public which is to file (and by the USPTO to process) an application. Confidentiality is governed by 35 U.S.C. 122 and 37 CFR 1.14. This collection is estimated to take 2 hours to complete, including gathering, preparing, and submitting the completed application form to the USPTO. Time will vary depending upon the individual case. Any comments on the amount of time you require to complete this form and/or suggestions for reducing this burden, should be sent to the Chief Information Officer, U.S. Patent and Trademark Office, P.O. Box 1450, Alexandria, VA 22313-1450. DO NOT SEND FEES OR COMPLETED FORMS TO THIS ADDRESS. SEND TO: Commissioner for Patents, P.O. Box 1450, Alexandria, VA 22313-1450.

If you need assistance in completing the form, call 1-800-PTO-9199 (1-800-786-9199) and select option 2.

ALL REFERENCES CONSIDERED EXCEPT WHERE LINED THROUGH. /I.O./

Under the Paperwork Reduction Act of 1995, no persons are required to respond to a collection of information unless it contains a valid OMB control number.

Substitute for form 1449/PTO <h2 style="text-align: center;">INFORMATION DISCLOSURE STATEMENT BY APPLICANT</h2> <p style="text-align: center;"><i>(Use as many sheets as necessary)</i></p>	<p style="text-align: center;">Complete if Known</p> <table border="1" style="width:100%; border-collapse: collapse;"> <tr> <td>Application Number</td> <td>11/895,388</td> </tr> <tr> <td>Filing Date</td> <td>August 24, 2007</td> </tr> <tr> <td>First Named Inventor</td> <td>Scott A. MOSKOWITZ</td> </tr> <tr> <td>Art Unit</td> <td>2132</td> </tr> <tr> <td>Examiner Name</td> <td>NA</td> </tr> <tr> <td>Attorney Docket Number</td> <td>80391.0003CONT2</td> </tr> </table>	Application Number	11/895,388	Filing Date	August 24, 2007	First Named Inventor	Scott A. MOSKOWITZ	Art Unit	2132	Examiner Name	NA	Attorney Docket Number	80391.0003CONT2
Application Number	11/895,388												
Filing Date	August 24, 2007												
First Named Inventor	Scott A. MOSKOWITZ												
Art Unit	2132												
Examiner Name	NA												
Attorney Docket Number	80391.0003CONT2												
Sheet <u>3</u> of <u>12</u>													

U. S. PATENT DOCUMENTS					
Examiner Initials*	Cite No. ¹	Document Number	Publication Date MM-DD-YYYY	Name of Patentee or Applicant of Cited Document	Pages, Columns, Lines, Where Relevant Passages or Relevant Figures Appear
		Number-Kind Code ² (if known)			
		US-4,528,588	07/09/1985	Lofberg	
		US-5,832,119	11/03/1998	Rhoads	
		US-5,859,920	01/12/1999	Daly et.al	
		US-4,979,210	12/18/1990	Nagata et.al	
		US-5,774,452	06/30/1998	Wolosewicz	
		US-4,405,829	09/20/1983	Rivest et.al	
		US-6,330,335	12/11/2001	Rhoads	
		US-3,986,624	10/19/1976	Cates Jr. et.al	
		US-5,363,448	11/08/1994	Koopman et.al	
		US-5,568,570	10/22/1996	Rabbani	
		US-5,636,292	06/03/1997	Rhoads	
		US-4,972,471	11/20/1990	Gross et.al.	
		US-5,893,067	04/06/1999	Bender et.al.	
		US-5,689,587	11/18/1997	Bender et.al.	
		US-3,984,624	10/05/1976	Waggener	
		US-4,038,596	07/26/1977	Lee	
		US-4,200,770	04/29/1980	Hellman, et.al.	
		US-4,218,582	08/19/1980	Hellman, et.al.	
		US-4,424,414	01/03/1984	Hellman, et.al.	

FOREIGN PATENT DOCUMENTS						
Examiner Initials*	Cite No. ¹	Foreign Patent Document	Publication Date MM-DD-YYYY	Name of Patentee or Applicant of Cited Document	Pages, Columns, Lines, Where Relevant Passages Or Relevant Figures Appear	T ⁶
		Country Code ³ Number ⁴ Kind Code ⁵ (if known)				
		WO 9744736	11/27/1997	Wehrenberg		
		WO 9952271	10/14/1999	Moskowitz		
		WO 9963443	12/09/1999	Ho,Anthony Tung Shuen		

Examiner Signature	/Izunna Okeke/	Date Considered	07/08/2015
--------------------	----------------	-----------------	------------

*EXAMINER: Initial if reference considered, whether or not citation is in conformance with MPEP 609. Draw line through citation if not in conformance and not considered. Include copy of this form with next communication to applicant. ¹ Applicant's unique citation designation number (optional). ² See Kinds Codes of USPTO Patent Documents at www.uspto.gov or MPEP 901.04. ³ Enter Office that issued the document, by the two-letter code (WIPO Standard ST.3). ⁴ For Japanese patent documents, the indication of the year of the reign of the Emperor must precede the serial number of the patent document. ⁵ Kind of document by the appropriate symbols as indicated on the document under WIPO Standard ST.16 if possible. ⁶ Applicant is to place a check mark here if English language Translation is attached.

This collection of information is required by 37 CFR 1.97 and 1.98. The information is required to obtain or retain a benefit by the public which is to file (and by the USPTO to process) an application. Confidentiality is governed by 35 U.S.C. 122 and 37 CFR 1.14. This collection is estimated to take 2 hours to complete, including gathering, preparing, and submitting the completed application form to the USPTO. Time will vary depending upon the individual case. Any comments on the amount of time you require to complete this form and/or suggestions for reducing this burden, should be sent to the Chief Information Officer, U.S. Patent and Trademark Office, P.O. Box 1450, Alexandria, VA 22313-1450. DO NOT SEND FEES OR COMPLETED FORMS TO THIS ADDRESS. SEND TO: Commissioner for Patents, P.O. Box 1450, Alexandria, VA 22313-1450.

If you need assistance in completing the form, call 1-800-PTO-9199 (1-800-786-9199) and select option 2.

ALL REFERENCES CONSIDERED EXCEPT WHERE LINED THROUGH. /I.O./

PTO/SB/08A (09-06)

Approved for use through 03/31/2007. OMB 0651-0031
U.S. Patent and Trademark Office; U.S. DEPARTMENT OF COMMERCE

Under the Paperwork Reduction Act of 1995, no persons are required to respond to a collection of information unless it contains a valid OMB control number.

Substitute for form 1449/PTO		Complete if Known	
INFORMATION DISCLOSURE STATEMENT BY APPLICANT <i>(Use as many sheets as necessary)</i>		Application Number	11/895,388
		Filing Date	August 24, 2007
		First Named Inventor	Scott A. MOSKOWITZ
		Art Unit	2132
		Examiner Name	NA
		Attorney Docket Number	80391.0003CONT2
Sheet	4	of	12

U. S. PATENT DOCUMENTS					
Examiner Initials*	Cite No. ¹	Document Number	Publication Date MM-DD-YYYY	Name of Patentee or Applicant of Cited Document	Pages, Columns, Lines, Where Relevant Passages or Relevant Figures Appear
		Number-Kind Code ² (if known)			
		US-5,640,569	06/17/1997	Miller, et. al.	
		US-5,659,726	08/19/1997	Sandford, II, et. al.	
		US-5,664,018	09/02/1997	Leighton	
		US-5,687,236	11/11/1997	Moskowitz, et. al.	
		US-5,734,752	03/31/1998	Knox	
		US-5,745,569	04/28/1998	Moskowitz, et. al.	
		US-5,506,795	04/09/1996	Yamakawa	
		US-5,680,462	10/21/1997	Miller, et. al.	
		US-5,696,828	12/09/1997	Koopman, Jr.	
		US-5,740,244	04/14/1998	Indeck, et. al.	
		US-5,751,811	05/12/1998	Koopman, Jr.	
		US-5,757,923	05/26/1998	Koopman, Jr.	
		US-5,889,868	03/30/1999	Moskowitz, et. al.	
		US-6,208,745	03/27/2001	Florenio, et. al.	
		US-6,285,775	09/04/2001	Wu, et. al.	
		US-6,385,329	05/07/2002	Sharma, et. al.	
		US-6,530,021	03/04/2003	Epstein, et. al.	
		US-6,425,081	07/23/2002	Iwamura	
		US-			

FOREIGN PATENT DOCUMENTS						
Examiner Initials*	Cite No. ¹	Foreign Patent Document	Publication Date MM-DD-YYYY	Name of Patentee or Applicant of Cited Document	Pages, Columns, Lines, Where Relevant Passages Or Relevant Figures Appear	T ⁶
		Country Code ³ Number ⁴ Kind Code ⁵ (if known)				

Examiner Signature	/Izunna Okeke/	Date Considered	07/08/2015
--------------------	----------------	-----------------	------------

*EXAMINER: Initial if reference considered, whether or not citation is in conformance with MPEP 609. Draw line through citation if not in conformance and not considered. Include copy of this form with next communication to applicant. ¹ Applicant's unique citation designation number (optional). ² See Kinds Codes of USPTO Patent Documents at www.uspto.gov or MPEP 901.04. ³ Enter Office that issued the document, by the two-letter code (WIPO Standard ST.3). ⁴ For Japanese patent documents, the indication of the year of the reign of the Emperor must precede the serial number of the patent document. ⁵ Kind of document by the appropriate symbols as indicated on the document under WIPO Standard ST.16 if possible. ⁶ Applicant is to place a check mark here if English language Translation is attached.

This collection of information is required by 37 CFR 1.97 and 1.98. The information is required to obtain or retain a benefit by the public which is to file (and by the USPTO to process) an application. Confidentiality is governed by 35 U.S.C. 122 and 37 CFR 1.14. This collection is estimated to take 2 hours to complete, including gathering, preparing, and submitting the completed application form to the USPTO. Time will vary depending upon the individual case. Any comments on the amount of time you require to complete this form and/or suggestions for reducing this burden, should be sent to the Chief Information Officer, U.S. Patent and Trademark Office, P.O. Box 1450, Alexandria, VA 22313-1450. DO NOT SEND FEES OR COMPLETED FORMS TO THIS ADDRESS. SEND TO: Commissioner for Patents, P.O. Box 1450, Alexandria, VA 22313-1450.

If you need assistance in completing the form, call 1-800-PTO-9199 (1-800-786-9199) and select option 2.

ALL REFERENCES CONSIDERED EXCEPT WHERE LINED THROUGH. /I.O./

PTO/SB/08A (09-06)

Approved for use through 03/31/2007. OMB 0651-0031

U.S. Patent and Trademark Office; U.S. DEPARTMENT OF COMMERCE

Under the Paperwork Reduction Act of 1995, no persons are required to respond to a collection of information unless it contains a valid OMB control number.

<p>Substitute for form 1449/PTO</p> <h2 style="text-align: center; margin: 10px 0;">INFORMATION DISCLOSURE STATEMENT BY APPLICANT</h2> <p style="text-align: center; font-size: small;">(Use as many sheets as necessary)</p>	<p style="text-align: center; font-weight: bold; margin: 0;">Complete if Known</p> <table style="width: 100%; border-collapse: collapse;"> <tr><td style="border: 1px solid black; padding: 2px;">Application Number</td><td style="padding: 2px;">11/895,388</td></tr> <tr><td style="border: 1px solid black; padding: 2px;">Filing Date</td><td style="padding: 2px;">August 24, 2007</td></tr> <tr><td style="border: 1px solid black; padding: 2px;">First Named Inventor</td><td style="padding: 2px;">Scott A. MOSKOWITZ</td></tr> <tr><td style="border: 1px solid black; padding: 2px;">Art Unit</td><td style="padding: 2px;">2132</td></tr> <tr><td style="border: 1px solid black; padding: 2px;">Examiner Name</td><td style="padding: 2px;">NA</td></tr> <tr><td style="border: 1px solid black; padding: 2px;">Attorney Docket Number</td><td style="padding: 2px;">80391.0003CONT2</td></tr> </table>	Application Number	11/895,388	Filing Date	August 24, 2007	First Named Inventor	Scott A. MOSKOWITZ	Art Unit	2132	Examiner Name	NA	Attorney Docket Number	80391.0003CONT2
Application Number	11/895,388												
Filing Date	August 24, 2007												
First Named Inventor	Scott A. MOSKOWITZ												
Art Unit	2132												
Examiner Name	NA												
Attorney Docket Number	80391.0003CONT2												

U. S. PATENT DOCUMENTS					
Examiner Initials*	Cite No. ¹	Document Number	Publication Date MM-DD-YYYY	Name of Patentee or Applicant of Cited Document	Pages, Columns, Lines, Where Relevant Passages or Relevant Figures Appear
		Number-Kind Code ² (if known)			
		US-6,522,769	02/18/2003	Rhoads, et.al.	
		US-2005/0160271	07/21/2005	Brundage, et.al	
		US-6,665,489	12/16/2003	Collart	
		US-2004/0128514	07/01/2004	Rhoads	
		US-2004/0037449	02/26/2004	Davis, et.al.	
		US-6,823,455	11/23/2004	Macy, et.al.	
		US-2003/0133702	07/17/2003	Collart	
		US-6,668,246	12/23/2003	Yeung, et.al.	
		US-6,405,203	06/11/2002	Collart	
		US-6,141,754	10/31/2000	Choy	
		US-6,493,457	12/10/2002	Quackenbush	
		US-5,629,980	05/13/1997	Stefik, et.al.	
		US-5,943,422	08/24/1999	Van Wie, et.al.	
		US-5,636,276	06/03/1997	Brugger	
		US-5,341,429	08/23/1994	Stringer, et.al.	
		US-6,754,822	06/22/2004	Zhao	
		US-6,131,162	10/10/2000	Yoshiura et.al.	
		US-7,058,570	06/06/2006	Yu, et.al.	
		US-			

FOREIGN PATENT DOCUMENTS						
Examiner Initials*	Cite No. ¹	Foreign Patent Document	Publication Date MM-DD-YYYY	Name of Patentee or Applicant of Cited Document	Pages, Columns, Lines, Where Relevant Passages Or Relevant Figures Appear	T ⁶
		Country Code ³ Number ⁴ Kind Code ⁵ (if known)				

Examiner Signature: /Izunna Okeke/	Date Considered: 07/08/2015
------------------------------------	-----------------------------

*EXAMINER: Initial if reference considered, whether or not citation is in conformance with MPEP 609. Draw line through citation if not in conformance and not considered. Include copy of this form with next communication to applicant. ¹ Applicant's unique citation designation number (optional). ² See Kinds Codes of USPTO Patent Documents at www.uspto.gov or MPEP 901.04. ³ Enter Office that issued the document, by the two-letter code (WIPO Standard ST.3). ⁴ For Japanese patent documents, the indication of the year of the reign of the Emperor must precede the serial number of the patent document. ⁵ Kind of document by the appropriate symbols as indicated on the document under WIPO Standard ST.16 if possible. ⁶ Applicant is to place a check mark here if English language Translation is attached.

This collection of information is required by 37 CFR 1.97 and 1.98. The information is required to obtain or retain a benefit by the public which is to file (and by the USPTO to process) an application. Confidentiality is governed by 35 U.S.C. 122 and 37 CFR 1.14. This collection is estimated to take 2 hours to complete, including gathering, preparing, and submitting the completed application form to the USPTO. Time will vary depending upon the individual case. Any comments on the amount of time you require to complete this form and/or suggestions for reducing this burden, should be sent to the Chief Information Officer, U.S. Patent and Trademark Office, P.O. Box 1450, Alexandria, VA 22313-1450. DO NOT SEND FEES OR COMPLETED FORMS TO THIS ADDRESS. SEND TO: Commissioner for Patents, P.O. Box 1450, Alexandria, VA 22313-1450.

If you need assistance in completing the form, call 1-800-PTO-9199 (1-800-786-9199) and select option 2.

ALL REFERENCES CONSIDERED EXCEPT WHERE LINED THROUGH. /I.O./

Under the Paperwork Reduction Act of 1995, no persons are required to respond to a collection of information unless it contains a valid OMB control number.

Substitute for form 1449/PTO		Complete if Known	
INFORMATION DISCLOSURE STATEMENT BY APPLICANT <i>(Use as many sheets as necessary)</i>		Application Number	11/895,388
		Filing Date	August 24, 2007
		First Named Inventor	Scott A. MOSKOWITZ
		Art Unit	2132
		Examiner Name	NA
		Attorney Docket Number	80391.0003CONT2
Sheet	6	of	12

U. S. PATENT DOCUMENTS					
Examiner Initials*	Cite No. ¹	Document Number	Publication Date MM-DD-YYYY	Name of Patentee or Applicant of Cited Document	Pages, Columns, Lines, Where Relevant Passages or Relevant Figures Appear
		Number-Kind Code ² (if known)			
		US-5,930,369	07/27/1999	Cox, et. al.	
		US-6,415,041	07/02/2002	Oami, et. al.	
		US-6,141,753	10/31/2000	Zhao, et. al.	
		US-2002/0097873	07/25/2002	Petrovic	
		US-6,785,815	08/31/2004	Serret-Avila, et. al.	
		US-6,523,113	02/18/2003	Wehrenberg	
		US-6,233,347	05/15/2001	Chen, et. al.	
		US-6,233,684	05/15/2001	Stefik, et. al.	
		US-2006/0013395	01/19/2006	Brundage, et. al.	
		US-7,043,050	05/09/2006	Yuval	
		US-5,809,160	09/15/1998	Powell, et. al.	
		US-6,272,634	08/07/2001	Tewfik, et. al.	
		US-6,282,650	08/28/2001	Davis	
		US-6,557,103	04/29/2003	Boncelet, Jr., et. al.	
		US-2003/0126445	07/03/2003	Wehrenberg	
		US-6,978,370	12/20/2005	Kocher	
		US-2006/0005029	01/05/2006	Petrovic, et. al.	
		US-6,278,791	08/21/2001	Honsinger, et. al.	
		US-			

FOREIGN PATENT DOCUMENTS						
Examiner Initials*	Cite No. ¹	Foreign Patent Document	Publication Date MM-DD-YYYY	Name of Patentee or Applicant of Cited Document	Pages, Columns, Lines, Where Relevant Passages Or Relevant Figures Appear	T ⁶
		Country Code ³ Number ⁴ Kind Code ⁵ (if known)				

Examiner Signature	/Izunna Okeke/	Date Considered	07/08/2015
--------------------	----------------	-----------------	------------

*EXAMINER: Initial if reference considered, whether or not citation is in conformance with MPEP 609. Draw line through citation if not in conformance and not considered. Include copy of this form with next communication to applicant. ¹ Applicant's unique citation designation number (optional). ² See Kinds Codes of USPTO Patent Documents at www.uspto.gov or MPEP 901.04. ³ Enter Office that issued the document, by the two-letter code (WIPO Standard ST.3). ⁴ For Japanese patent documents, the indication of the year of the reign of the Emperor must precede the serial number of the patent document. ⁵ Kind of document by the appropriate symbols as indicated on the document under WIPO Standard ST.16 if possible. ⁶ Applicant is to place a check mark here if English language Translation is attached.

This collection of information is required by 37 CFR 1.97 and 1.98. The information is required to obtain or retain a benefit by the public which is to file (and by the USPTO to process) an application. Confidentiality is governed by 35 U.S.C. 122 and 37 CFR 1.14. This collection is estimated to take 2 hours to complete, including gathering, preparing, and submitting the completed application form to the USPTO. Time will vary depending upon the individual case. Any comments on the amount of time you require to complete this form and/or suggestions for reducing this burden, should be sent to the Chief Information Officer, U.S. Patent and Trademark Office, P.O. Box 1450, Alexandria, VA 22313-1450. DO NOT SEND FEES OR COMPLETED FORMS TO THIS ADDRESS. SEND TO: Commissioner for Patents, P.O. Box 1450, Alexandria, VA 22313-1450.

If you need assistance in completing the form, call 1-800-PTO-9199 (1-800-786-9199) and select option 2.

ALL REFERENCES CONSIDERED EXCEPT WHERE LINED THROUGH. /I.O./

Under the Paperwork Reduction Act of 1995, no persons are required to respond to a collection of information unless it contains a valid OMB control number.

Substitute for form 1449/PTO <h2 style="text-align: center; margin: 0;">INFORMATION DISCLOSURE STATEMENT BY APPLICANT</h2> <p style="text-align: center; font-size: small;">(Use as many sheets as necessary)</p>	<p style="text-align: center; font-weight: bold; margin: 0;">Complete if Known</p> <table style="width: 100%; border-collapse: collapse;"> <tr> <td style="border-bottom: 1px solid black; width: 40%;">Application Number</td> <td>11/895,388</td> </tr> <tr> <td style="border-bottom: 1px solid black;">Filing Date</td> <td>August 24, 2007</td> </tr> <tr> <td style="border-bottom: 1px solid black;">First Named Inventor</td> <td>Scott A. MOSKOWITZ</td> </tr> <tr> <td style="border-bottom: 1px solid black;">Art Unit</td> <td>2132</td> </tr> <tr> <td style="border-bottom: 1px solid black;">Examiner Name</td> <td>NA</td> </tr> <tr> <td style="border-bottom: 1px solid black;">Attorney Docket Number</td> <td>80391.0003CONT2</td> </tr> </table>	Application Number	11/895,388	Filing Date	August 24, 2007	First Named Inventor	Scott A. MOSKOWITZ	Art Unit	2132	Examiner Name	NA	Attorney Docket Number	80391.0003CONT2
Application Number	11/895,388												
Filing Date	August 24, 2007												
First Named Inventor	Scott A. MOSKOWITZ												
Art Unit	2132												
Examiner Name	NA												
Attorney Docket Number	80391.0003CONT2												
Sheet <u>7</u> of <u>12</u>													

U. S. PATENT DOCUMENTS					
Examiner Initials*	Cite No. ¹	Document Number	Publication Date MM-DD-YYYY	Name of Patentee or Applicant of Cited Document	Pages, Columns, Lines, Where Relevant Passages or Relevant Figures Appear
		Number-Kind Code ² (if known)			
		US-6,598,162	07/22/2003	Moskowitz	
		US-6,275,988	08/14/2001	Nagashima, et al.	
		US-6,051,029	04/18/2000	Paterson, et al.	
		US-5,917,915	06/29/1999	Hirose	
		US-6,775,772	08/10/2004	Binding, et al.	
		US-6,668,246	12/23/2003	Yeung, et al.	
		US-6,351,765	02/26/2002	Pietro Paolo, et al.	
		US-6,049,838	04/11/2000	Miller, et al.	
		US-5,398,285	03/14/1995	Borgelt, et al.	
		US-5,737,733	04/07/1998	Eller	
		US-2002/0103883	08/01/2002	Haverstock, et al.	
		US-5,673,316	09/30/1997	Auerbach, et al.	
		US-6,647,424	11/11/2003	Pearson, et al.	
		US-6,977,894	12/20/2005	Achilles, et al.	
		US-6,453,252	09/17/2002	Laroche	
		US-5,077,665	12/31/1991	Silverman, et al.	
		US-5,136,581	08/04/1992	Muehrcke	
		US-5,341,477	08/23/1994	Pitkin, et al.	
		US-5,581,703	12/03/1996	Baugher, et al.	

FOREIGN PATENT DOCUMENTS						
Examiner Initials*	Cite No. ¹	Foreign Patent Document	Publication Date MM-DD-YYYY	Name of Patentee or Applicant of Cited Document	Pages, Columns, Lines, Where Relevant Passages Or Relevant Figures Appear	T ⁶
		Country Code ³ Number ⁴ Kind Code ⁵ (if known)				

Examiner Signature	/Izunna Okeke/	Date Considered	07/08/2015
--------------------	----------------	-----------------	------------

*EXAMINER: Initial if reference considered, whether or not citation is in conformance with MPEP 609. Draw line through citation if not in conformance and not considered. Include copy of this form with next communication to applicant. ¹ Applicant's unique citation designation number (optional). ² See Kinds Codes of USPTO Patent Documents at www.uspto.gov or MPEP 901.04. ³ Enter Office that issued the document, by the two-letter code (WIPO Standard ST.3). ⁴ For Japanese patent documents, the indication of the year of the reign of the Emperor must precede the serial number of the patent document. ⁵ Kind of document by the appropriate symbols as indicated on the document under WIPO Standard ST.16 if possible. ⁶ Applicant is to place a check mark here if English language Translation is attached.

This collection of information is required by 37 CFR 1.97 and 1.98. The information is required to obtain or retain a benefit by the public which is to file (and by the USPTO to process) an application. Confidentiality is governed by 35 U.S.C. 122 and 37 CFR 1.14. This collection is estimated to take 2 hours to complete, including gathering, preparing, and submitting the completed application form to the USPTO. Time will vary depending upon the individual case. Any comments on the amount of time you require to complete this form and/or suggestions for reducing this burden, should be sent to the Chief Information Officer, U.S. Patent and Trademark Office, P.O. Box 1450, Alexandria, VA 22313-1450. DO NOT SEND FEES OR COMPLETED FORMS TO THIS ADDRESS. SEND TO: Commissioner for Patents, P.O. Box 1450, Alexandria, VA 22313-1450.

If you need assistance in completing the form, call 1-800-PTO-9199 (1-800-786-9199) and select option 2.

ALL REFERENCES CONSIDERED EXCEPT WHERE LINED THROUGH. /I.O./

PTO/SB/08A (09-06)

Approved for use through 03/31/2007. OMB 0651-0031
U.S. Patent and Trademark Office; U.S. DEPARTMENT OF COMMERCE

Under the Paperwork Reduction Act of 1995, no persons are required to respond to a collection of information unless it contains a valid OMB control number.

Substitute for form 1449/PTO <h2 style="text-align: center; margin: 0;">INFORMATION DISCLOSURE STATEMENT BY APPLICANT</h2> <p style="text-align: center; font-size: small;">(Use as many sheets as necessary)</p>	<p style="text-align: center; font-weight: bold; margin: 0;">Complete if Known</p> <table style="width: 100%; border-collapse: collapse;"> <tr> <td style="border-bottom: 1px solid black; width: 40%;">Application Number</td> <td>11/895,388</td> </tr> <tr> <td style="border-bottom: 1px solid black;">Filing Date</td> <td>August 24, 2007</td> </tr> <tr> <td style="border-bottom: 1px solid black;">First Named Inventor</td> <td>Scott A. MOSKOWITZ</td> </tr> <tr> <td style="border-bottom: 1px solid black;">Art Unit</td> <td>2132</td> </tr> <tr> <td style="border-bottom: 1px solid black;">Examiner Name</td> <td>NA</td> </tr> <tr> <td style="border-bottom: 1px solid black;">Attorney Docket Number</td> <td>80391.0003CONT2</td> </tr> </table>	Application Number	11/895,388	Filing Date	August 24, 2007	First Named Inventor	Scott A. MOSKOWITZ	Art Unit	2132	Examiner Name	NA	Attorney Docket Number	80391.0003CONT2
Application Number	11/895,388												
Filing Date	August 24, 2007												
First Named Inventor	Scott A. MOSKOWITZ												
Art Unit	2132												
Examiner Name	NA												
Attorney Docket Number	80391.0003CONT2												
Sheet <u>8</u> of <u>12</u>													

U. S. PATENT DOCUMENTS					
Examiner Initials*	Cite No. ¹	Document Number	Publication Date MM-DD-YYYY	Name of Patentee or Applicant of Cited Document	Pages, Columns, Lines, Where Relevant Passages or Relevant Figures Appear
		Number-Kind Code ² (if known)			
		US-5,548,579	08/20/1996	Lebrun, et al.	
		US-5,905,975	05/18/1999	Ausubel	
		US-6,457,058	09/24/2002	Ullum et al.	
		US-6,381,618	04/30/2002	Jones et al.	
		US-2002/0026343	02/28/2002	Duenke	
		US-6,230,268	05/08/2001	Miwa et al.	
		US-6,199,058	03/06/2001	Wong et al.	
		US-5,920,900	07/06/1999	Poole et al.	
		US-5,884,033	03/16/1999	Duvall et al.	
		US-5,478,990	12/26/1995	Montanari et al.	
		US-6,430,302	08/06/2002	Rhoads	
		US-6,725,372	04/20/2004	Lewis et al.	
		US-6,606,393	08/12/2003	Xie et al.	
		US-6,584,125	06/24/2003	Katto	
		US-6,442,283	08/27/2002	Tewfik et al.	
		US-6,377,625	04/23/2002	Kim	
		US-6,282,300	08/28/2001	Bloom et al.	
		US-6,205,249	03/20/2001	Moskowitz	
		US-6,029,126	02/22/2000	Malvar	

FOREIGN PATENT DOCUMENTS						
Examiner Initials*	Cite No. ¹	Foreign Patent Document	Publication Date MM-DD-YYYY	Name of Patentee or Applicant of Cited Document	Pages, Columns, Lines, Where Relevant Passages Or Relevant Figures Appear	* ⁶
		Country Code ³ *Number ⁴ *Kind Code ⁵ (if known)				

Examiner Signature	/izunna Okeke/	Date Considered	07/08/2015
--------------------	----------------	-----------------	------------

*EXAMINER: Initial if reference considered, whether or not citation is in conformance with MPEP 609. Draw line through citation if not in conformance and not considered. Include copy of this form with next communication to applicant. ¹ Applicant's unique citation designation number (optional). ² See Kinds Codes of USPTO Patent Documents at www.uspto.gov or MPEP 901.04. ³ Enter Office that issued the document, by the two-letter code (WIPO Standard ST.3). ⁴ For Japanese patent documents, the indication of the year of the reign of the Emperor must precede the serial number of the patent document. ⁵ Kind of document by the appropriate symbols as indicated on the document under WIPO Standard ST.16 if possible. ⁶ Applicant is to place a check mark here if English language Translation is attached.

This collection of information is required by 37 CFR 1.97 and 1.98. The information is required to obtain or retain a benefit by the public which is to file (and by the USPTO to process) an application. Confidentiality is governed by 35 U.S.C. 122 and 37 CFR 1.14. This collection is estimated to take 2 hours to complete, including gathering, preparing, and submitting the completed application form to the USPTO. Time will vary depending upon the individual case. Any comments on the amount of time you require to complete this form and/or suggestions for reducing this burden, should be sent to the Chief Information Officer, U.S. Patent and Trademark Office, P.O. Box 1450, Alexandria, VA 22313-1450. DO NOT SEND FEES OR COMPLETED FORMS TO THIS ADDRESS. SEND TO: Commissioner for Patents, P.O. Box 1450, Alexandria, VA 22313-1450.

If you need assistance in completing the form, call 1-800-PTO-9199 (1-800-786-9199) and select option 2.

ALL REFERENCES CONSIDERED EXCEPT WHERE LINED THROUGH. /I.O./

PTO/SB/08A (09-06)

Approved for use through 03/31/2007. OMB 0651-0031

U.S. Patent and Trademark Office; U.S. DEPARTMENT OF COMMERCE

Under the Paperwork Reduction Act of 1995, no persons are required to respond to a collection of information unless it contains a valid OMB control number.

Substitute for form 1449/PTO <h2 style="text-align: center; margin: 0;">INFORMATION DISCLOSURE STATEMENT BY APPLICANT</h2> <p style="text-align: center; font-size: small;">(Use as many sheets as necessary)</p>	<p style="text-align: center; font-weight: bold; margin: 0;">Complete if Known</p> <table style="width: 100%; border-collapse: collapse;"> <tr> <td style="border: 1px solid black; padding: 2px;">Application Number</td> <td style="padding: 2px;">11/895,388</td> </tr> <tr> <td style="border: 1px solid black; padding: 2px;">Filing Date</td> <td style="padding: 2px;">August 24, 2007</td> </tr> <tr> <td style="border: 1px solid black; padding: 2px;">First Named Inventor</td> <td style="padding: 2px;">Scott A. MOSKOWITZ</td> </tr> <tr> <td style="border: 1px solid black; padding: 2px;">Art Unit</td> <td style="padding: 2px;">2132</td> </tr> <tr> <td style="border: 1px solid black; padding: 2px;">Examiner Name</td> <td style="padding: 2px;">NA</td> </tr> <tr> <td style="border: 1px solid black; padding: 2px;">Attorney Docket Number</td> <td style="padding: 2px;">80391.0003CONT2</td> </tr> </table>	Application Number	11/895,388	Filing Date	August 24, 2007	First Named Inventor	Scott A. MOSKOWITZ	Art Unit	2132	Examiner Name	NA	Attorney Docket Number	80391.0003CONT2
Application Number	11/895,388												
Filing Date	August 24, 2007												
First Named Inventor	Scott A. MOSKOWITZ												
Art Unit	2132												
Examiner Name	NA												
Attorney Docket Number	80391.0003CONT2												
Sheet <u>9</u> of <u>12</u>													

U. S. PATENT DOCUMENTS					
Examiner Initials*	Cite No. ¹	Document Number	Publication Date MM-DD-YYYY	Name of Patentee or Applicant of Cited Document	Pages, Columns, Lines, Where Relevant Passages or Relevant Figures Appear
		Number-Kind Code ² (if known)			
		US-5,754,697	05/19/1998	Fu et al.	
		US-5,479,210	12/26/1995	Cawley et al.	
		US-3,947,825	03/30/1976	Cassada	
		US-5,903,721	05/11/1999	Sixtus	
		US-5,790,677	08/04/1998	Fox et al.	
		US-5,243,515	09/07/1993	Clearwater	
		US-4,339,134	07/13/1982	Macheel	
		US-4,827,508	05/02/1989	Shear	
		US-4,896,275	01/23/1990	Jackson	
		US-4,977,594	12/11/1990	Shear	
		US-5,050,213	09/17/1991	Shear	
		US-5,369,707	11/29/1994	Follendore, III	
		US-5,406,627	04/11/1995	Thompson et al.	
		US-5,410,598	04/25/1995	Shear	
		US-5,469,536	11/21/1995	Blank	
		US-5,497,419	03/05/1996	Hill	
		US-5,513,261	04/30/1996	Maher	
		US-5,530,739	06/25/1996	Okada	
		US-5,598,470	01/28/1997	Cooper et al.	

FOREIGN PATENT DOCUMENTS						
Examiner Initials*	Cite No. ¹	Foreign Patent Document	Publication Date MM-DD-YYYY	Name of Patentee or Applicant of Cited Document	Pages, Columns, Lines, Where Relevant Passages Or Relevant Figures Appear	T ⁶
		Country Code ³ Number ⁴ Kind Code ⁵ (if known)				

Examiner Signature	/izunna Okeke/	Date Considered	07/08/2015
-----------------------	----------------	--------------------	------------

*EXAMINER: Initial if reference considered, whether or not citation is in conformance with MPEP 609. Draw line through citation if not in conformance and not considered. Include copy of this form with next communication to applicant. ¹ Applicant's unique citation designation number (optional). ² See Kinds Codes of USPTO Patent Documents at www.uspto.gov or MPEP 901.04. ³ Enter Office that issued the document, by the two-letter code (WIPO Standard ST.3). ⁴ For Japanese patent documents, the indication of the year of the reign of the Emperor must precede the serial number of the patent document. ⁵ Kind of document by the appropriate symbols as indicated on the document under WIPO Standard ST.16 if possible. ⁶ Applicant is to place a check mark here if English language Translation is attached.

This collection of information is required by 37 CFR 1.97 and 1.98. The information is required to obtain or retain a benefit by the public which is to file (and by the USPTO to process) an application. Confidentiality is governed by 35 U.S.C. 122 and 37 CFR 1.14. This collection is estimated to take 2 hours to complete, including gathering, preparing, and submitting the completed application form to the USPTO. Time will vary depending upon the individual case. Any comments on the amount of time you require to complete this form and/or suggestions for reducing this burden, should be sent to the Chief Information Officer, U.S. Patent and Trademark Office, P.O. Box 1450, Alexandria, VA 22313-1450. DO NOT SEND FEES OR COMPLETED FORMS TO THIS ADDRESS. SEND TO: Commissioner for Patents, P.O. Box 1450, Alexandria, VA 22313-1450.

If you need assistance in completing the form, call 1-800-PTO-9199 (1-800-786-9199) and select option 2.

ALL REFERENCES CONSIDERED EXCEPT WHERE LINED THROUGH. /I.O./

PTO/SB/08A (09-06)
 Approved for use through 03/31/2007. OMB 0651-0031
 U.S. Patent and Trademark Office; U.S. DEPARTMENT OF COMMERCE

Under the Paperwork Reduction Act of 1995, no persons are required to respond to a collection of information unless it contains a valid OMB control number.

Substitute for form 1449/PTO <h2 style="text-align: center; margin: 0;">INFORMATION DISCLOSURE STATEMENT BY APPLICANT</h2> <p style="text-align: center; font-size: small;">(Use as many sheets as necessary)</p>	<p style="text-align: right; font-weight: bold; margin: 0;">Complete if Known</p> <table border="1" style="width: 100%; border-collapse: collapse;"> <tr><td style="width: 40%;">Application Number</td><td>11/895,388</td></tr> <tr><td>Filing Date</td><td>August 24, 2007</td></tr> <tr><td>First Named Inventor</td><td>Scott A. MOSKOWITZ</td></tr> <tr><td>Art Unit</td><td>2132</td></tr> <tr><td>Examiner Name</td><td>NA</td></tr> <tr><td>Attorney Docket Num</td><td>80391.0003CONT2</td></tr> </table>	Application Number	11/895,388	Filing Date	August 24, 2007	First Named Inventor	Scott A. MOSKOWITZ	Art Unit	2132	Examiner Name	NA	Attorney Docket Num	80391.0003CONT2
Application Number	11/895,388												
Filing Date	August 24, 2007												
First Named Inventor	Scott A. MOSKOWITZ												
Art Unit	2132												
Examiner Name	NA												
Attorney Docket Num	80391.0003CONT2												
Sheet <u>10</u> of <u>12</u>													

U. S. PATENT DOCUMENTS					
Examiner Initials*	Cite No. ¹	Document Number	Publication Date	Name of Patentee or Applicant of Cited Document	Pages, Columns, Lines, Where Relevant Passages or Relevant Figures Appear
		Number-Kind Code ² (if known)	MM-DD-YYYY		
		US-5,625,690	04/29/1997	Michel et al.	
		US-5,633,932	05/27/1997	Davis et al.	
		US-5,719,937	02/17/1998	Warren et al.	
		US-5,737,416	04/07/1998	Cooper et al.	
		US-5,765,152	06/09/1998	Erickson	
		US-5,799,083	08/25/1998	Brothers et al.	
		US-5,973,731	10/26/1999	Schwab	
		US-5,894,521	04/13/1999	Conley	
		US-5,905,800	05/18/1999	Moskowitz et al.	
		US-5,963,909	10/05/1999	Warren et al.	
		US-5,974,141	10/26/1999	Saito	
		US-5,999,217	12/07/1999	Berners-Lee	
		US-6,041,316	03/21/2000	Allen	
		US-6,081,251	06/27/2000	Sakai et al.	
		US-6,278,780	08/21/2001	Shimada	
		US-6,301,663	10/09/2001	Kato et al.	
		US-6,240,121	05/29/2001	Senoh	
		US-			
		US-			

FOREIGN PATENT DOCUMENTS						
Examiner Initials*	Cite No. ¹	Foreign Patent Document	Publication Date	Name of Patentee or Applicant of Cited Document	Pages, Columns, Lines, Where Relevant Passages Or Relevant Figures Appear	T ⁶
		Country Code ³ -Number ⁴ -Kind Code ⁵ (if known)	MM-DD-YYYY			

Examiner Signature	/Izunna Okeke/	Date Considered	07/08/2015
--------------------	----------------	-----------------	------------

*EXAMINER: Initial if reference considered, whether or not citation is in conformance with MPEP 609. Draw line through citation if not in conformance and not considered. Include copy of this form with next communication to applicant. ¹ Applicant's unique citation designation number (optional). ² See Kinds Codes of USPTO Patent Documents at www.uspto.gov or MPEP 901.04. ³ Enter Office that issued the document, by the two-letter code (WIPO Standard ST.3). ⁴ For Japanese patent documents, the indication of the year of the reign of the Emperor must precede the serial number of the patent document. ⁵ Kind of document by the appropriate symbols as indicated on the document under WIPO Standard ST.16 if possible. ⁶ Applicant is to place a check mark here if English language Translation is attached.

This collection of information is required by 37 CFR 1.97 and 1.98. The information is required to obtain or retain a benefit by the public which is to file (and by the USPTO to process) an application. Confidentiality is governed by 35 U.S.C. 122 and 37 CFR 1.14. This collection is estimated to take 2 hours to complete, including gathering, preparing, and submitting the completed application form to the USPTO. Time will vary depending upon the individual case. Any comments on the amount of time you require to complete this form and/or suggestions for reducing this burden, should be sent to the Chief Information Officer, U.S. Patent and Trademark Office, P.O. Box 1450, Alexandria, VA 22313-1450. DO NOT SEND FEES OR COMPLETED FORMS TO THIS ADDRESS. SEND TO: Commissioner for Patents, P.O. Box 1450, Alexandria, VA 22313-1450.

If you need assistance in completing the form, call 1-800-PTO-9199 (1-800-786-9199) and select option 2.

ALL REFERENCES CONSIDERED EXCEPT WHERE LINED THROUGH. /I.O./

PTO/SB/08A (10-07)
Approved for use through 10/31/2007. OMB 0651-0031
U.S. Patent and Trademark Office; U.S. DEPARTMENT OF COMMERCE

Under the Paperwork Reduction Act of 1995, no persons are required to respond to a collection of information unless it contains a valid OMB control number.

Substitute for form 1449/PTO		Complete if Known	
INFORMATION DISCLOSURE STATEMENT BY APPLICANT <i>(Use as many sheets as necessary)</i>		Application Number	11/895,388
		Filing Date	August 24, 2007
		First Named Inventor	Scott A. MOSKOWITZ
		Art Unit	2132
		Examiner Name	NA
Sheet <u>11</u> of <u>12</u>	Attorney Docket Numl	80391.0003CONT2	

U. S. PATENT DOCUMENTS					
Examiner Initials*	Cite No. ¹	Document Number	Publication Date MM-DD-YYYY	Name of Patent Applicant of Cited Document	Relevant Passages or Relevant Figures Appear
		Number-Kind Code ² (if known)			
		US- 6,088,455	07/11/2000	Logan et al.	
		US- 5,634,040	05/27/1997	Her et al.	
		US- 6,381,747	04/30/2002	Wonfor et al.	
		US- 4,969,204	11/06/1990	Melnychuck et al.	
		US- 6,966,002	11/15/2005	Torrubia-Saez	
		US- 6,263,313	07/17/2001	Milstead, et al.	
		US- 7,093,295	08/15/2006	Saito	
		US- 6,587,837	07/01/2003	Spagna et al.	
		US- 6,931,534	08/16/2005	Jandel et al.	
		US- 2004/0049695	03/11/2004	Choi et al.	
		US- 2004/0083369	04/29/2004	Erlingsson et al.	
		US- 5,677,952	10/14/1997	Blakely et al.	
		US- 5,768,396	06/16/1998	Sone	
		US- 7,266,697	09/04/2007	Kirovski et al.	
		US- 5,136,646	08/04/1992	Haber et al.	
		US- 5,136,647	08/04/1992	Haber et al.	
		US- 7,206,649	04/17/2007	Kirovski et al.	
		US- 6,532,284	03/11/2003	Walker et al.	
		US- 7,020,285	03/28/2006	Kirovski et al.	

FOREIGN PATENT DOCUMENTS						
Examiner Initials*	Cite No. ¹	Foreign Patent Document	Publication Date MM-DD-YYYY	Name of Patentee or Applicant of Cited Document	Pages, Columns, Lines, Where Relevant Passages Or Relevant Figures Appear	T ⁶
		Country Code ³ Number ⁴ Kind Code ⁵ (if known)				

Examiner Signature	/Izunna Okeke/	Date Considered	07/08/2015
--------------------	----------------	-----------------	------------

*EXAMINER: Initial if reference considered, whether or not citation is in conformance with MPEP 609. Draw line through citation if not in conformance and not considered. Include copy of this form with next communication to applicant. ¹ Applicant's unique citation designation number (optional). ² See Kinds Codes of USPTO Patent Documents at www.uspto.gov or MPEP 901.04. ³ Enter Office that issued the document, by the two-letter code (WIPO Standard ST.3). ⁴ For Japanese patent documents, the indication of the year of the reign of the Emperor must precede the serial number of the patent document. ⁵ Kind of document by the appropriate symbols as indicated on the document under WIPO Standard ST.16 if possible. ⁶ Applicant is to place a check mark here if English language Translation is attached.

This collection of information is required by 37 CFR 1.97 and 1.98. The information is required to obtain or retain a benefit by the public which is to file (and by the USPTO to process) an application. Confidentiality is governed by 35 U.S.C. 122 and 37 CFR 1.14. This collection is estimated to take 2 hours to complete, including gathering, preparing, and submitting the completed application form to the USPTO. Time will vary depending upon the individual case. Any comments on the amount of time you require to complete this form and/or suggestions for reducing this burden, should be sent to the Chief Information Officer, U.S. Patent and Trademark Office, P.O. Box 1450, Alexandria, VA 22313-1450. DO NOT SEND FEES OR COMPLETED FORMS TO THIS ADDRESS. SEND TO: Commissioner for Patents, P.O. Box 1450, Alexandria, VA 22313-1450.

If you need assistance in completing the form, call 1-800-PTO-9199 (1-800-786-9199) and select option 2.

ALL REFERENCES CONSIDERED EXCEPT WHERE LINED THROUGH. /I.O./

PTO/SB/08A (10-07)

Approved for use through 10/31/2007. OMB 0651-0031

U.S. Patent and Trademark Office
Under the Paperwork Reduction Act of 1995, no persons are required to respond to a collection of information unless it displays this identification number.

Substitute for form 1449/PTO

INFORMATION DISCLOSURE STATEMENT BY APPLICANT

(Use as many sheets as necessary)

Application Number
Filing Date
First Named Inventor
Art Unit
Examiner Name
Attorney Docket Num

11/895,388
August 24, 2007
Scott A. MOSKOWITZ
2132
NA
80391.0003CONT2

Sheet 12 of 12

U. S. PATENT DOCUMENTS

Examiner Initials*	Cite No. ¹	Document Number	Publication Date MM-DD-YYYY	Name of Patentee or Applicant of Cited Document	Pages, Columns, Lines, Where Relevant Passages or Relevant Figures Appear
		Number-Kind Code ² (if known)			
		US- 7,046,808	05/12/2006	Metois et al.	
		US- 6,430,301	08/06/2002	Petrovic	
		US- 2004/0059918	03/25/2004	Xu	
		US- 6,345,100	02/05/2002	Levine	
		US- 2004/0093521	05/13/2004	Hamadeh et al.	
		US- 2007/0083467	04/12/2007	Lindahl et al.	
		US- 7,231,524	06/12/2007	Burns	
		US- 2005/0246554	11/03/2005	Batson	
		US- 6,668,325	02/23/2003	Collberg et al.	
		US- 7,050,396	05/23/2006	Cohen et al.	
		US- 6,842,862	01/11/2005	Chow et al.	
		US- 7,051,208	05/23/2006	Venkatesan et al.	
		US- 7,240,210	07/03/2007	Michak et al.	
		US- 7,150,003	12/12/2006	Naumovich et al.	
		US-			
		US-			
		US-			
		US-			
		US-			

FOREIGN PATENT DOCUMENTS

Examiner Initials*	Cite No. ¹	Foreign Patent Document	Publication Date MM-DD-YYYY	Name of Patentee or Applicant of Cited Document	Pages, Columns, Lines, Where Relevant Passages Or Relevant Figures Appear	T ⁶
		Country Code ³ Number ⁴ Kind Code ⁵ (if known)				

Examiner Signature: /Izunna Okeke/ Date Considered: 07/08/2015

*EXAMINER: Initial if reference considered, whether or not citation is in conformance with MPEP 609. Draw line through citation if not in conformance and not considered. Include copy of this form with next communication to applicant. ¹ Applicant's unique citation designation number (optional). ² See Kinds Codes of USPTO Patent Documents at www.uspto.gov or MPEP 901.04. ³ Enter Office that issued the document, by the two-letter code (WIPO Standard ST.3). ⁴ For Japanese patent documents, the indication of the year of the reign of the Emperor must precede the serial number of the patent document. ⁵ Kind of document by the appropriate symbols as indicated on the document under WIPO Standard ST.16 if possible. ⁶ Applicant is to place a check mark here if English language Translation is attached.

This collection of information is required by 37 CFR 1.97 and 1.98. The information is required to obtain or retain a benefit by the public which is to file (and by the USPTO to process) an application. Confidentiality is governed by 35 U.S.C. 122 and 37 CFR 1.14. This collection is estimated to take 2 hours to complete, including gathering, preparing, and submitting the completed application form to the USPTO. Time will vary depending upon the individual case. Any comments on the amount of time you require to complete this form and/or suggestions for reducing this burden, should be sent to the Chief Information Officer, U.S. Patent and Trademark Office, P.O. Box 1450, Alexandria, VA 22313-1450. DO NOT SEND FEES OR COMPLETED FORMS TO THIS ADDRESS. SEND TO: Commissioner for Patents, P.O. Box 1450, Alexandria, VA 22313-1450.

If you need assistance in completing the form, call 1-800-PTO-9199 (1-800-786-9199) and select option 2.

ALL REFERENCES CONSIDERED EXCEPT WHERE LINED THROUGH. /I.O./

Receipt date: 03/20/2015

11895388 - GAU: 2432

Printed: March 20, 2015 (12:02pm)

Path: Y:\Clients\SCOT Scott A Moskowitz and Wistaria Trading,

Inc\SCOT0014-4\Drafts\ReferenceCitationList_SCOT0014-4_3-12-2015.wpd

37 CFR 1.98(a)(1)(i) APPLICATION & ATTORNEY DOCKET: 11/895,388 / SCOT0014-4

37 CFR 1.98(a)(1)(iii): THIS IS AN INFORMATION DISCLOSURE STATEMENT

Change(s) applied
to document,
/E.M.S./
6/16/2015

EXAMINER INITIALS	REFERENCE NUMBER (F SERIES)	PUBLICATION NUMBER	PUBLICATION DATE	COUNTRY OR REGION	PAGE/LINE AND FIGURE/ELEMENT OF RELEVANT MATERIAL	REFERENCES CITED AND CONSIDERED BY EXAMINER IN PARENT CASE IDENTIFIED BY PLACEMENT OF "X"
	F 023-	WO0203385	Jan 2002	WO		X
	F 024-	WO9701892	June 1995	WO	01/16/1997	X
	F 025-	WO9726732	July 1997	WO		X
	F 026-	WO9802864	Jan 1998	WO		X
	F 027-	EP1547337	Mar 2006	EP		X
	F 028-	EP0581317A2	Feb 1994	EP		X
	F 029-	WO023385A1	Oct 2002	WO		X

DATE:	EXAMINER'S SIGNATURE:
-------	-----------------------

ALL REFERENCES CONSIDERED EXCEPT WHERE LINED THROUGH. //I.O./

Printed: November 19, 2010 (12:45pm)

Path: Y:\Clients\SCOT Scott A Moskowitz and Wistaria Trading, Inc\SCOT0014-4\Drafts\IDS_SCOT00014-4_11-19-2010.wpd

37 CFR 1.98(a)(1)(i) APPLICATION:

37 CFR 1.98(a)(1)(iii): THIS IS AN INFORMATION DISCLOSURE STATEMENT

Change(s) applied
to document,
/E.M.S./
6/16/2015

EXAMINER INITIALS	REFERENCE NUMBER (F SERIES)	PUBLICATION NUMBER	PUBLICATION DATE	COUNTRY OR REGION	PAGE/LINE AND FIGURE/ELEMENT OF RELEVANT MATERIAL	ENGLISH LANGUAGE TRANSLATION ATTACHED? (YES OR NO) AND/OR IDENTIFICATION OF PRIORITY APPLICATION IN WHICH REFERENCE IS CITED
	F 021-	WO0118628	March 2001	WO		
	F 022-	WO0143026	June 2001	WO		
	F 023-	WO0203385	Jan 2002	WO		
	F 024-	WO9701892	June 1995	WO	01/16/1997	
	F 025-	WO9726732	July 1997	WO		
	F 026-	WO9802864	Jan 1998	WO		
	F 027-	EP1547337	Mar 2006	EP		
	F 028-	EP0581317A2	Feb 1994	EP		
	F 029-	WO023385A1	Oct 2002	WO		

DATE: 03/17/2011	EXAMINER'S SIGNATURE: /Izunna Okeke/
------------------	--------------------------------------

ALL REFERENCES CONSIDERED EXCEPT WHERE LINED THROUGH. //I.O./

Printed: March 20, 2015 (12:02pm)

Path: Y:\Clients\SCOT Scott A Moskowitz and Wistaria Trading,

Inc\SCOT0014-4\Drafts\ReferenceCitationList_SCOT0014-4_3-12-2015.wpd

37 CFR 1.98(a)(1)(i) APPLICATION & ATTORNEY DOCKET: 11/895,388 / SCOT0014-4

37 CFR 1.98(a)(1)(iii): THIS IS AN INFORMATION DISCLOSURE STATEMENT

EXAMINER INITIAL	REF. NO. (L series)	REFERENCE NUMBER (L Series)	PUB. DATE	INCLUDE IN SEQUENCE: Name of first author (in CAPITAL LETTERS), Title in quotation marks, name of publication, date or publication, page numbers, publisher, city of publication, and country of publication NOTE - For US patent applications listed herein, if a	REFERENCES CITED AND CONSIDERED BY EXAMINER IN PARENT CASE IDENTIFIED BY PLACEMENT OF "X"
	196	L- 0196	N/A	PCT Application No. PCT/US99/07262, filed Apr. 2, 1999, entitled, "Multiple Transform Utilization and Applications for Secure Digital Watermarking", published as WO/1999/052271; Publication Date: 14.10.1999.	X
	197	L- 0197	N/A	PCT Application No. PCT/US00/06522, filed Mar. 14, 2000, entitled, "Utilizing Data Reduction in Steganographic and Cryptographic Systems", published as WO/2000/057643; Publication Date: 28.09.2000.	X
	198	L- 0198	N/A	PCT Application No. PCT/US00/18411, filed Jul. 5, 2000, entitled, "Copy Protection of Digital Data Combining Steganographic and Cryptographic Techniques"	X
	199	L- 0199	N/A	PCT Application No. PCT/US00/33126, filed Dec. 7, 2000, entitled "Systems, Methods and Devices for Trusted Transactions", published as WO/2001/043026; Publication Date: 14.06.2001.	X
	200	L- 0200	N/A	EPO Divisional Patent Application No. 07112420.0, entitled "Steganographic Method and Device" corresponding to PCT Application No. PCT/US96/10257, published as WO/1996/042151, 12/27/1996, cited herein above as F019.	X
	201	L- 0201	N/A	US Provisional Application 60/222,023 filed July 31, 2007 entitled "Method and apparatus for recognizing sound and signals in high noise and distortion"	X
	202	L- 0202	N/A	US Application 11/458,639 filed July 19, 2006 entitled "Methods and Systems for Inserting Watermarks in Digital Signals", published as 20060251291 A1 11-09-2006, P82.	X Rhoads
	203	L- 0203	1995	"Techniques for Data Hiding in Audio Files," by Morimoto, 1995	X
	204	L- 0204	1998	Howe, Dennis July 13, 1998 http://foi.doc.org/steganography	X
	205	L- 0205	N/A	CSG, Computer Support Group and CSGNetwork.com 1973 http://www.csgnetwork.com/glossarys.html	X

Change(s) applied to document, /D.D./ 6/27/2015

DATE:	EXAMINER'S SIGNATURE:
-------	-----------------------

ALL REFERENCES CONSIDERED EXCEPT WHERE LINED THROUGH. //I.O./

Printed: March 20, 2015 (12:02pm)

Path: Y:\Clients\SCOT Scott A Moskowitz and Wistaria Trading,

Inc\SCOT0014-4\Drafts\ReferenceCitationList_SCOT0014-4_3-12-2015.wpd

37 CFR 1.98(a)(1)(i) APPLICATION & ATTORNEY DOCKET: 11/895,388 / SCOT0014-4

37 CFR 1.98(a)(1)(iii): THIS IS AN INFORMATION DISCLOSURE STATEMENT

EXAMINER INITIAL	REF. NO. (L series)	REFERENCE NUMBER (L Series)	PUB. DATE	INCLUDE IN SEQUENCE: Name of first author (in CAPITAL LETTERS), Title in quotation marks, name of publication, date or publication, page numbers, publisher, city of publication, and country of publication NOTE - For US patent applications listed herein, if a	REFERENCES CITED AND CONSIDERED BY EXAMINER IN PARENT CASE IDENTIFIED BY PLACEMENT OF "X"
	188	L- 0188	N/A	U.S. Appl. No. 12/590,681, filed Nov. 12, 2009, entitled "Optimization Methods for the Insertion, Protection, and Detection of Digital Watermarks in Digital Data", published as 20100064140 A1 03-11-2010, P79.	X Moskowitz
	189	L- 0189	N/A	U.S. Appl. No. 12/655,036, filed Dec. 22, 2009, entitled "Utilizing Data Reduction in Steganographic and Cryptographic Systems", published as 20100153734 A1 06-17-2010, P80. Moskowitz; Scott A.; et al.	X
	190	L- 0190	N/A	U.S. Appl. No. 12/655,357, filed Dec. 22, 2009, entitled "Method And Device For Monitoring And Analyzing Signals", published as 20100106736 A1 04-29-2010, P81.	X Moskowitz et al.
Change(s) applied to document, /D.D./ 6/27/2015	191	L- 0191	N/A	PCT Application No. PCT/US95/08159, filed Jun. 26, 1995, entitled, "Digital Information Commodities Exchange with Virtual Menuing", published as WO/1997/001892; Publication Date: 16.01.1997, F24.	X
	192	L- 0192	N/A	PCT Application No. PCT/US96/10257, filed Jun. 7, 1996, entitled "Steganographic Method and Device"--corresponding to--EPO Application No. 96919405.9, entitled "Steganographic Method and Device", published as WO/1996/042151; Publication Date: 27.12.1996; F19.	X
	193	L- 0193	N/A	PCT Application No. PCT/US97/00651, filed Jan. 16, 1997, entitled, "Method for Stega-Cipher Protection of Computer Code", published as WO/1997/026732; Publication Date: 24.07.1997.	X
	194	L- 0194	N/A	PCT Application No. PCT/US97/00652, filed Jan. 17, 1997, entitled, "Method for an Encrypted Digital Watermark", published as WO/1997/026733; Publication Date: 24.07.1997	X
	195	L- 0195	N/A	PCT Application No. PCT/US97/11455, filed Jul. 2, 1997, entitled, "Optimization Methods for the Insertion, Protection and Detection of Digital Watermarks in Digitized Data", published as WO/1998/002864; Publication Date: 22.01.1998	X

DATE:	EXAMINER'S SIGNATURE:
-------	-----------------------

ALL REFERENCES CONSIDERED EXCEPT WHERE LINED THROUGH. //I.O./

Printed: March 20, 2015 (12:02pm)

Path: Y:\Clients\SCOT Scott A Moskowitz and Wistaria Trading,

Inc\SCOT0014-4\Drafts\ReferenceCitationList_SCOT0014-4_3-12-2015.wpd

37 CFR 1.98(a)(1)(i) APPLICATION & ATTORNEY DOCKET: 11/895,388 / SCOT0014-4

37 CFR 1.98(a)(1)(iii): THIS IS AN INFORMATION DISCLOSURE STATEMENT

EXAMINER INITIAL	REF. NO. (L series)	REFERENCE NUMBER (L Series)	PUB. DATE	INCLUDE IN SEQUENCE: Name of first author (in CAPITAL LETTERS), Title in quotation marks, name of publication, date or publication, page numbers, publisher, city of publication, and country of publication NOTE - For US patent applications listed herein, if a	REFERENCES CITED AND CONSIDERED BY EXAMINER IN PARENT CASE IDENTIFIED BY PLACEMENT OF "X"
	179	L- 0179	2001	VeriDisc, "The Search for a Rational Solution to Digital Rights Management (DRM)", http://64.244.235.240/news/whitepaper/docs/veridisc.sub.--white.sub.--paper.pdf , 2001, 15 pp.	X
	180	L- 0180	2008	Cayre, et al., "Kerckhoff's-Based Embedding Security Classes for WOA Data Hiding", IEEE Transactions on Information Forensics and Security, vol. 3 No. 1, Mar. 2008, 15 pp.	X
	181	L- 0181	1999	Wayback Machine, dated Jan. 17, 1999, http://web.archive.org/web/19990117020420/http://www.netzero.com/ , accessed on Feb. 19, 2008.	X
	182	L- 0182	1997	Namgoong, H., "An Integrated Approach to Legacy Data for Multimedia Applications", Proceedings of the 23rd EUROMICRO Conference, vol., Issue 1-4, Sep. 1997, pp. 387-391.	X
	183	L- 0183	2007	Wayback Machine, dated Aug. 26, 2007, http://web.archive.org/web/20070826151732/http://www.screenplaysmag.com/t-abid/96/articleType/ArticleView/articleId/495/Default.aspx/ .	X
	184	L- 0184	2009	"YouTube Copyright Policy: Video Identification tool--YouTube Help", accessed Jun. 4, 2009, http://www.google.com/support/youtube/bin/answer.py?hl=en&answer=83766 , 3 pp.	X
	185	L- 0185	N/A	U.S. Appl. No. 12/665,002, filed Dec. 22, 2009, entitled "Method for Combining Transfer Function with Predetermined Key Creation", published as 20100182570 A1 07-22-2010, P76. <u>Matsumoto; Chota; et al.</u>	X
	186	L- 0186	N/A	U.S. Appl. No. 12/592,331, filed Nov. 23, 2009, entitled "Optimization Methods for the Insertion, Protection, and Detection of Digital Watermarks in Digital Data", published as 20100077220 A1 03-25-2010, P77. <u>Moskowitz</u>	X
	187	L- 0187	N/A	U.S. Appl. No. 12/590,553, filed Nov. 10, 2009, entitled "Optimization Methods for the Insertion, Protection, and Detection of Digital Watermarks in Digital Data", published as 20100077219 A1 03-25-2010, P78. <u>Moskowitz</u>	X

Change(s) applied to document, /D.D./ 6/27/2015

DATE:	EXAMINER'S SIGNATURE:
-------	-----------------------

ALL REFERENCES CONSIDERED EXCEPT WHERE LINED THROUGH. /I.O./

Printed: March 20, 2015 (12:02pm)

Path: Y:\Clients\SCOT Scott A Moskowitz and Wistaria Trading,

Inc\SCOT0014-4\Drafts\ReferenceCitationList_SCOT0014-4_3-12-2015.wpd

37 CFR 1.98(a)(1)(i) APPLICATION & ATTORNEY DOCKET: 11/895,388 / SCOT0014-4

37 CFR 1.98(a)(1)(iii): THIS IS AN INFORMATION DISCLOSURE STATEMENT

Change(s) applied
to document,
/D.D./
6/27/2015

EXAMINER INITIAL	REF. NO. (L series)	REFERENCE NUMBER (L Series)	PUB. DATE	INCLUDE IN SEQUENCE: Name of first author (in CAPITAL LETTERS), Title in quotation marks, name of publication, date or publication, page numbers, publisher, city of publication, and country of publication NOTE - For US patent applications listed herein, if a	REFERENCES CITED AND CONSIDERED BY EXAMINER IN PARENT CASE IDENTIFIED BY PLACEMENT OF "X"
	34	L- 034	N/A	U.S. Appl. No. 09/731,039, filed Dec. 7, 2000, entitled "System and Methods for Permitting Open Access to Data Objects and for Securing Data within the Data Objects", published as 2002-0071556 A1 06-13-2002, cited herein as Moskowitz et al.	X
	35	L- 035	N/A	U.S. Appl. No. 11/647,861, filed Dec. 29, 2006, entitled "System and Methods for Permitting Open Access to Data Objects and for Securing Data within the Data Objects", published as 2007-0110240 A1 05-17-2007, cited herein as Moskowitz et al.	X
	36	L- 036	1996	Schneier, Bruce, Applied Cryptography, 2nd Ed., John Wiley & Sons, pp. 9-10, 1996.	X
	37	L- 037	1997	Menezes, Alfred J., Handbook of Applied Cryptography, CRC Press, p. 46, 1997.	X
	38	L- 038	1997	Merriam-Webster's Collegiate Dictionary, 10th Ed., Merriam Webster, Inc., p. 207.	X
	39	L- 039	1984	Brealy, et al., Principles of Corporate Finance, "Appendix A--Using Option Valuation Models", 1984, pp. 448-449.	X
	40	L- 040	2001	Copeland, et al., Real Options: A Practitioner's Guide, 2001 pp. 106-107, 201-202, 204-208.	X
	41	L- 041	1995	Sarkar, M. "An Assessment of Pricing Mechanisms for the Internet-A Regulatory Imperative", presented MIT Workshop on Internet Economics, Mar. 1995 http://www.press.vmich.edu/ieep/works/SarkAsses.html on.	X
	42	L- 042	1995	Crawford, D.W. "Pricing Network Usage: A Market for Bandwidth of Market Communication?" presented MIT Workshop on Internet Economics, Mar. 1995 http://www.press.vmich.edu/ieep/works/CrawMarket.html on March.	X
	43	L- 043	1988	Low, S.H., "Equilibrium Allocation and Pricing of Variable Resources Among User-Suppliers", 1988. http://www.citeseer.nj.nec.com/366503.html .	X

DATE:	EXAMINER'S SIGNATURE:
-------	-----------------------

ALL REFERENCES CONSIDERED EXCEPT WHERE LINED THROUGH. /I.O./

Printed: March 20, 2015 (12:02pm)

Path: Y:\Clients\SCOT Scott A Moskowitz and Wistaria Trading,

Inc\SCOT0014-4\Drafts\ReferenceCitationList_SCOT0014-4_3-12-2015.wpd

37 CFR 1.98(a)(1)(i) APPLICATION & ATTORNEY DOCKET: 11/895,388 / SCOT0014-4

37 CFR 1.98(a)(1)(iii): THIS IS AN INFORMATION DISCLOSURE STATEMENT

Change(s) applied
to document,
/D.D./
6/27/2015

EXAMINER INITIAL	REF. NO. (L series)	REFERENCE NUMBER (L Series)	PUB. DATE	INCLUDE IN SEQUENCE: Name of first author (in CAPITAL LETTERS), Title in quotation marks, name of publication, date or publication, page numbers, publisher, city of publication, and country of publication NOTE - For US patent applications listed herein, if a	REFERENCES CITED AND CONSIDERED BY EXAMINER IN PARENT CASE IDENTIFIED BY PLACEMENT OF "X"
	26	L- 026	N/A	U.S. Appl. No. 10/049,101, filed Feb. 8, 2002, entitled "A Secure Personal Content Server", published as 7,475,246 01-06-2009, cited herein as U277. Moskowitz, et al.	X
	27	L- 027	N/A	PCT Application No. PCT/US00/21189, filed Aug. 4, 2000, entitled, "A Secure Personal Content Server", Pub. No.: WO/2001/018628 ; Publication Date: 15.03.2001, cited herein as F21.	X
	28	L- 028	N/A	U.S. Appl. No. 09/657,181, filed Sep. 7, 2000, entitled "Method and Device For Monitoring And Analyzing Signals", published as 7,346,472 03-18-2008, cited herein as U271. Moskowitz, et al.	X
	29	L- 029	N/A	U.S. Appl. No. 10/805,484, filed Mar. 22, 2004, entitled "Method And Device For Monitoring And Analyzing Signals", published as 2004-0243540 A1 12-02-2004, cited herein as P27. Moskowitz, et al.	X
	30	L- 030	N/A	U.S. Appl. No. 09/956,262, filed Sep. 20, 2001, entitled "Improved Security Based on Subliminal and Supraliminal Channels For Data Objects", published as 2002-0056041 A1 05-09-2002, cited herein as P05 Moskowitz	X
	31	L- 031	N/A	U.S. Appl. No. 11/518,806, filed Sep. 11, 2006, entitled "Improved Security Based on Subliminal and Supraliminal Channels For Data Objects", 2008-0028222 A1 01-31-2008, cited herein as P57. Moskowitz	X
	32	L- 032	N/A	U.S. Appl. No. 11/026,234, filed Dec. 30, 2004, entitled "Z-Transform Implementation of Digital Watermarks", published as 2005-0135615 A1 06-23-2005, cited herein as P28. Moskowitz et al.	X
	33	L- 033	N/A	U.S. Appl. No. 11/592,079, filed Nov. 2, 2006, entitled "Linear Predictive Coding Implementation of Digital Watermarks", published as 2007-0079131 A1 04-05-2007, cited herein as P42. Moskowitz et al.	X

DATE:	EXAMINER'S SIGNATURE:
-------	-----------------------

ALL REFERENCES CONSIDERED EXCEPT WHERE LINED THROUGH. /I.O./

Printed: March 20, 2015 (12:02pm)

Path: Y:\Clients\SCOT Scott A Moskowitz and Wistaria Trading,

Inc\SCOT0014-4\Drafts\ReferenceCitationList_SCOT0014-4_3-12-2015.wpd

37 CFR 1.98(a)(1)(i) APPLICATION & ATTORNEY DOCKET: 11/895,388 / SCOT0014-4

37 CFR 1.98(a)(1)(iii): THIS IS AN INFORMATION DISCLOSURE STATEMENT

Change(s) applied
to document,
/D.D./
6/27/2015

EXAMINER INITIAL	REF. NO. (L series)	REFERENCE NUMBER (L Series)	PUB. DATE	INCLUDE IN SEQUENCE: Name of first author (in CAPITAL LETTERS), Title in quotation marks, name of publication, date or publication, page numbers, publisher, city of publication, and country of publication NOTE - For US patent applications listed herein, if a	REFERENCES CITED AND CONSIDERED BY EXAMINER IN PARENT CASE IDENTIFIED BY PLACEMENT OF "X"
	18	L- 018	N/A	U.S. Appl. No. 11/599,964, filed Nov. 15, 2006, entitled "Optimization Methods for the Insertion, Protection, and Detection of Digital Watermarks in Digital Data", published as 2008-0046742 A1 02-21-2008, cited herein as P58.	X Moskowitz
	19	L- 019	N/A	U.S. Appl. No. 11/599,838, filed Nov. 15, 2006, entitled "Optimization Methods for the Insertion, Protection, and Detection of Digital Watermarks in Digital Data", published as 2007-0226506 A1 09-27-2007, cited herein as P47.	X Moskowitz
	20	L- 020	N/A	U.S. Appl. No. 10/369,344, filed Feb. 18, 2003, entitled "Optimization Methods for the Insertion, Protection, and Detection of Digital Watermarks in Digitized Data", published as 2003-0219143 A1 11-27-2003, cited herein as P14. Moskowitz	X
	21	L- 021	N/A	U.S. Appl. No. 11/482,654, filed Jul. 7, 2006, entitled "Optimization Methods for the Insertion, Protection, and Detection of Digital Watermarks in Digitized Data", published as 2006-0285722 A1 12-21-2006, cited herein as P38. Moskowitz et al.	X
	22	L- 022	N/A	U.S. Appl. No. 09/594,719, filed Jun. 16, 2000, entitled "Utilizing Data Reduction in Steganographic and Cryptographic Systems", published as 7,123,718 10-17-2006, cited herein as U255. Moskowitz, et al.	X
	23	L- 023	N/A	U.S. Appl. No. 11/519,467, filed Sep. 12, 2006, entitled "Utilizing Data Reduction in Steganographic and Cryptographic Systems", published as 2007-0064940 A1 03-22-2007, cited herein as P41. Moskowitz et al.	X
	24	L- 024	N/A	U.S. Appl. No. 09/731,040, filed Dec. 7, 2000, entitled "Systems, Methods And Devices For Trusted Transactions", 2002-0010684 A1 01-24-2002, cited herein as P3.	X Moskowitz
	25	L- 025	N/A	U.S. Appl. No. 11/512,701, filed Aug. 29, 2006, entitled "Systems, Methods And Devices For Trusted Transactions", published as 2007-0028113 A1 02-01-2007, cited herein as P40. Moskowitz	X

DATE:	EXAMINER'S SIGNATURE:
-------	-----------------------

ALL REFERENCES CONSIDERED EXCEPT WHERE LINED THROUGH. //I.O./

Printed: March 20, 2015 (12:02pm)

Path: Y:\Clients\SCOT Scott A Moskowitz and Wistaria Trading,

Inc\SCOT0014-4\Drafts\ReferenceCitationList_SCOT0014-4_3-12-2015.wpd

37 CFR 1.98(a)(1)(i) APPLICATION & ATTORNEY DOCKET: 11/895,388 / SCOT0014-4

37 CFR 1.98(a)(1)(iii): THIS IS AN INFORMATION DISCLOSURE STATEMENT

Change(s) applied
to document,
/D.D./
6/27/2015

EXAMINER INITIAL	REF. NO. (L series)	REFERENCE NUMBER (L Series)	PUB. DATE	INCLUDE IN SEQUENCE: Name of first author (in CAPITAL LETTERS), Title in quotation marks, name of publication, date or publication, page numbers, publisher, city of publication, and country of publication NOTE - For US patent applications listed herein, if a	REFERENCES CITED AND CONSIDERED BY EXAMINER IN PARENT CASE IDENTIFIED BY PLACEMENT OF "X"
	10	L- 010	N/A	U.S. Appl. No. 09/053,628, filed Apr. 2, 1998, entitled "Multiple Transform Utilization and Application for Secure Digital Watermarking", 6,205,249 03-20-2001, cited herein as U161. <i>Moskowitz</i>	X
	11	L- 011	N/A	U.S. Appl. No. 09/644,098, filed Aug. 23, 2000, entitled "Multiple Transform Utilization and Application for Secure Digital Watermarking", published as 7,035,409 04-25-2006, cited herein as U245. <i>Moskowitz</i>	X
	12	L- 012	N/A	Jap. App. No. 2000-542907, entitled "Multiple Transform Utilization and Application for Secure Digital Watermarking"; which is a JP national stage of PCT/US1999/007262, published as WO/1999/052271, 10/14/1999, F13 here in above..	X
	13	L- 013	N/A	U.S. Appl. No. 09/767,733, filed Jan. 24, 2001 entitled "Multiple Transform Utilization and Application for Secure Digital Watermarking", published as 2001-0010078 A1 07-26-2001, cited herein as P1. <i>Moskowitz</i>	X
	14	L- 014	N/A	U.S. Appl. No. 11/358,874, filed Feb. 21, 2006, entitled "Multiple Transform Utilization and Application for Secure Digital Watermarking", published as 2006-0140403 A1 06-29-2006, cited herein as P37. <i>Moskowitz</i>	X
	15	L- 015	N/A	U.S. Appl. No. 10/417,231, filed Apr. 17, 2003, entitled "Methods, Systems And Devices For Packet Watermarking And Efficient Provisioning Of Bandwidth", published as 2003-0200439 A1 10-23-2003, cited herein as P13, <i>Moskowitz</i>	X
	16	L- 016	N/A	U.S. Appl. No. 09/789,711, filed Feb. 22, 2001, entitled "Optimization Methods for the Insertion, Protection, and Detection of Digital Watermarks in Digital Data", published as 2001-0029580 A1 10-11-2001, cited herein as P75. <i>Moskowitz</i>	X
	17	L- 017	N/A	U.S. Appl. No. 11/497,822, filed Aug. 2, 2006, entitled "Optimization Methods for the Insertion, Protection, and Detection of Digital Watermarks in Digital Data", published as 2007-0011458 A1 01-11-2007, cited herein as P39. <i>Moskowitz</i>	X

DATE:	EXAMINER'S SIGNATURE:
-------	-----------------------

ALL REFERENCES CONSIDERED EXCEPT WHERE LINED THROUGH. //I.O./

Printed: March 20, 2015 (12:02pm)

Path: Y:\Clients\SCOT Scott A Moskowitz and Wistaria Trading,

Inc\SCOT0014-4\Drafts\ReferenceCitationList_SCOT0014-4_3-12-2015.wpd

37 CFR 1.98(a)(1)(i) APPLICATION & ATTORNEY DOCKET: 11/895,388 / SCOT0014-4

37 CFR 1.98(a)(1)(iii): THIS IS AN INFORMATION DISCLOSURE STATEMENT

LISTING OF NON PATENT LITERATURE - L Series

EXAMINER INITIAL	REF. NO. (L series)	REFERENCE NUMBER (L Series)	PUB. DATE	INCLUDE IN SEQUENCE: Name of first author (in CAPITAL LETTERS), Title in quotation marks, name of publication, date or publication, page numbers, publisher, city of publication, and country of publication NOTE - For US patent applications listed herein, if a	REFERENCES CITED AND CONSIDERED BY EXAMINER IN PARENT CASE IDENTIFIED BY PLACEMENT OF "X"
	1	L- 01	N/A	US. Appl. No. 08/999,766, filed Jul. 23, 1997, entitled "Steganographic Method and Device", published as 7568100 07-28-2009, cited as U280. Moskowitz,	X et al.
	2	L- 02	N/A	EPO Application No. 96919405.9, entitled "Steganographic Method and Device"; published as EP0872073 (A2), 10-21-1998, cited herein as F20.	X
	3	L- 03	N/A	U.S. Appl. No. 11/050,779, filed Feb. 7, 2005, entitled "Steganographic Method and Device", published as 20050177727 A1 08-11-2005, cited herein as P30.	X Moskowitz et al.
	4	L- 04	N/A	U.S. Appl. No. 08/674,726, filed Jul. 2, 1996, entitled "Exchange Mechanisms for Digital Information Packages with Bandwidth Securitization, Multichannel Digital Watermarks, and Key Management", published as 7362775 04-22-2008, cited herein as U272 .	X Moskowitz
	5	L- 05	N/A	U.S. Appl. No. 09/545,589, filed Apr. 7, 2000, entitled "Method and System for Digital Watermarking", published as 7007166 02-28-2006, cited herein as U243	X Moskowitz, et al.
	6	L- 06	N/A	U.S. Appl. No. 11/244,213, filed Oct. 5, 2005, entitled "Method and System for Digital Watermarking", published as 2006-0101269 A1 05-11-2006, cited herein as P36	X Moskowitz et al.
	7	L- 07	N/A	U.S. Appl. No. 11/649,026, filed Jan. 3, 2007, entitled "Method and System for Digital Watermarking", published as 2007-0113094 A1 05-17-2007, cited herein as P45.	X Moskowitz et al.
Change(s) applied to document /D.D./ 6/27/2015	8	L- 08	N/A	U.S. Appl. No. 09/046,627, filed Mar. 24, 1998, entitled "Method for Combining Transfer Function with Predetermined Key Creation", published as 6,598,162 07-22-2003, cited herein as U212.	X Moskowitz
	9	L- 09	N/A	U.S. Appl. No. 10/602,777, filed Jun. 25, 2003, entitled "Method for Combining Transfer Function with Predetermined Key Creation", published as 2004-0086119 A1 05-06-2004, cited herein P20.	X Moskowitz

DATE:	EXAMINER'S SIGNATURE:
-------	-----------------------

ALL REFERENCES CONSIDERED EXCEPT WHERE LINED THROUGH. //I.O./

Receipt date: 03/20/2015

11895388 - GAU: 2432

Printed: March 20, 2015 (12:02pm)

Path: Y:\Clients\SCOT Scott A Moskowitz and Wistaria Trading,

Inc\SCOT0014-4\Drafts\ReferenceCitationList_SCOT0014-4_3-12-2015.wpd

37 CFR 1.98(a)(1)(i) APPLICATION & ATTORNEY DOCKET: 11/895,388 / SCOT0014-4

37 CFR 1.98(a)(1)(iii): THIS IS AN INFORMATION DISCLOSURE STATEMENT

LISTING OF FOREIGN AND INTERNATIONAL PATENT DOCUMENTS - F Series

EXAMINER INITIALS	REFERENCE NUMBER (F SERIES)	PUBLICATION NUMBER	PUBLICATION DATE	COUNTRY OR REGION	PAGE/LINE AND FIGURE/ELEMENT OF RELEVANT MATERIAL	REFERENCES CITED AND CONSIDERED BY EXAMINER IN PARENT CASE IDENTIFIED BY PLACEMENT OF "X"
	F 01-	EP0372601	Jun., 1990	EP		X
	F 02-	EP0565947	Oct., 1993	EP		X
	F 03-	EP0581317	Feb., 1994	EP		X
	F 04-	EP0649261	Apr., 1995	EP		X
	F 05-	EP0651554	May., 1995	EP		X
	F 06-	EP1354276	Dec., 2007	EP		X
	F 07-	NL 1005523	Sep., 1998	NL		X
	F 08-	WO 9514289	May., 1995	WO		X
	F 09-	WO 9629795	Sep., 1996	WO		X
	F 010-	WO 9724833	Jul., 1997	WO		X
	F 011-	WO 9744736	Nov., 1997	WO		X
	F 012-	WO9837513	Aug., 1998	WO		X
	F 013-	WO 9952271	Oct., 1999	WO		X
	F 014-	WO 9962044	Dec., 1999	WO		X
	F 015-	WO 9963443	Dec., 1999	WO		X
	F 016-	WO9726733	Jan. 1997	WO		X
	F 017-	WO98002864	Jul. 1997	WO	1998-01	X
	F 018-	WO 0057643	Sept 2000	WO		X
	F 019-	WO 9642151	Dec 1996	WO		X
	F 020-	EP0872073	July 1996	EP		X
	F 021-	WO0118628	March 2001	WO		X
	F 022-	WO0143026	June 2001	WO		X

Change(s) applied to document, /D.D./ 6/27/2015

DATE:	EXAMINER'S SIGNATURE:
-------	-----------------------

ALL REFERENCES CONSIDERED EXCEPT WHERE LINED THROUGH. //I.O./

Receipt date: 03/20/2015

11895388 - GAU: 2432

Printed: March 20, 2015 (12:02pm)

Path: Y:\Clients\SCOT Scott A Moskowitz and Wistaria Trading,

Inc\SCOT0014-4\Drafts\ReferenceCitationList_SCOT0014-4_3-12-2015.wpd

37 CFR 1.98(a)(1)(i) APPLICATION & ATTORNEY DOCKET: 11/895,388 / SCOT0014-4

37 CFR 1.98(a)(1)(iii): THIS IS AN INFORMATION DISCLOSURE STATEMENT

Change(s) applied

to document

/D.D./

6/27/2015

EXAMINER INITIALS	REFERENCE NUMBER (P SERIES)	PUBLICATION NUMBER	PUBLICATION DATE	NAME OF PATENTEE OR APPLICANT	REFERENCES CITED AND CONSIDERED BY EXAMINER IN PARENT CASE IDENTIFIED BY PLACEMENT OF "X"
	P 069	20100005308	January 2010	Moskowitz	X
	P 070	20100098251	Apr 2010	Moskowitz	X
	P 071	20100220861	Sept 2010	Moskowitz	X
	P 072	20100202607	Aug 2010	Moskowitz	X
20020097873	P 073	20020047873	June 2002	Petrovic	X
	P 074	20020009208	Jan 2002	Alattar	X
	P 075	20010029580	October 2001	Moskowitz	X
Matsumoto; et al.	P 076	20100182570	July 2010	Chota	X
	P 077	20100077220	March 2010	Moskowitz	X
	P 078	20100077219	March 2010	Moskowitz	X
	P 079	20100064140	March 2010	Moskowitz	X
	P 080	20100153734	June 2010	Moskowitz	X
	P 081	20100106736	April 2010	Moskowitz	X
	P 082	20060251291	November 2006	Rhoads	X
	P 083	20030002862	January 2003	Rodriguez	
	P 084	20030005780	May 2003	Hansen	January 9, 2003
	P 085	20020152179	Oct 2002	Racov	
	P 086	20030027549	Feb 2003	Kiel	
	P 087	20020057651	May 2002	Roberts	
	P 088	20110069864	March 2011	Moskowitz	
	P 089	20100313033	Dec 2010	Moskowitz	
	P 090	20110019691	Jan 2011	Moskowitz	
	P 091	20030023852	Jan. 2003	Wold	

07-2002

Matsumoto; et al.

January 9, 2003

DATE:	EXAMINER'S SIGNATURE:
-------	-----------------------

ALL REFERENCES CONSIDERED EXCEPT WHERE LINED THROUGH. //I.O./

Receipt date: 03/20/2015

11895388 - GAU: 2432

Printed: March 20, 2015 (12:02pm)

Path: Y:\Clients\SCOT Scott A Moskowitz and Wistaria Trading,

Inc\SCOT0014-4\Drafts\ReferenceCitationList_SCOT0014-4_3-12-2015.wpd

37 CFR 1.98(a)(1)(i) APPLICATION & ATTORNEY DOCKET: 11/895,388 / SCOT0014-4

37 CFR 1.98(a)(1)(iii): THIS IS AN INFORMATION DISCLOSURE STATEMENT

Change(s) applied
to document,
/D.D./
6/27/2015

EXAMINER INITIALS	REFERENCE NUMBER (U SERIES)	PATENT NUMBER	ISSUE DATE	NAME OF PATENTEE OR APPLICANT	REFERENCES CITED AND CONSIDERED BY EXAMINER IN PARENT CASE IDENTIFIED BY PLACEMENT OF "X"
	U 0367	6556976	Aug 1987	Callen	
	U 0368	6574608	Jun 2003	Dahod	
	U 0369	6601044	Jul 2003	Wallman	
	U 0370	6594643	Jul 2003	Freeny	
	U 0371	6618188	Sep 2003	Haga	
	U 0372	6778968	Aug 2004	Gulati	
	U 0373	6839686	Jan 2005	Galant	
	U 0374	6856867	Feb 2005	Woolston	6,856,967
	U 0375	6876982	Apr 2005	Lancaster	
	U 0376	7003480	Feb 2006	Fox	
	U 0377	5822436	Oct 1998	Rhoads	
	U 0378	6324649	Nov 2001	Eyres	
	U 0379	5375055	Dec 1994	Togher	
	U 0380	6018722	Jan 2000	Ray	
	U 0381	6138239	Oct 2000	Veil	
	U 0382	6484153	Nov 2002	Walker	
	U 0383	6615188	Aug 2004	Breen	September 2, 2003
	U 0384	6856967	Jan 2005	Woolston	
	U 0385	5790783	Aug 1998	Lee	
	U 0386	6650761	Nov 2003	Rodriguez	
	U 0387	6735702	May 2004	Yavatkar	
	U 0388	6792424	Sept 2004	Burns	
	U 0389	4790564	Dec 1988	Larcher	

DATE:	EXAMINER'S SIGNATURE:
-------	-----------------------

ALL REFERENCES CONSIDERED EXCEPT WHERE LINED THROUGH. //I.O./

Receipt date: 03/20/2015

11895388 - GAU: 2432

Printed: March 20, 2015 (12:02pm)

Path: Y:\Clients\SCOT Scott A Moskowitz and Wistaria Trading,

Inc\SCOT0014-4\Drafts\ReferenceCitationList_SCOT0014-4_3-12-2015.wpd

37 CFR 1.98(a)(1)(i) APPLICATION & ATTORNEY DOCKET: 11/895,388 / SCOT0014-4

37 CFR 1.98(a)(1)(iii): THIS IS AN INFORMATION DISCLOSURE STATEMENT

Change(s) applied
to document,
/D.D./
6/27/2015

EXAMINER INITIALS	REFERENCE NUMBER (U SERIES)	PATENT NUMBER	ISSUE DATE	NAME OF PATENTEE OR APPLICANT	REFERENCES CITED AND CONSIDERED BY EXAMINER IN PARENT CASE IDENTIFIED BY PLACEMENT OF "X"
	U 0321	5901178	May 1999	Lee	
	U 0322	8214175	July 2012	Moskowitz	
	U 0323	8265278	Sept 2012	Moskowitz	
	U 0324	8161286	Nov 2010	Moskowitz	April 17, 2012
	U 0325	8307213	Jan 2011	Moskowitz	November 6, 2012
	U 0326	8121343	May 2012	Moskowitz	February 2, 2012
	U 0327	5437050	Jul 1995	Lamb	
	U 0328	5123045	Jun 1992	Ostrovsky	
	U 0329	7310815	Dec 2007	Yanovsky	
	U 0330	8179846	May 2012	Dolganow	
	U 0331	7719966	May 2010	Luft	
	U 0332	7630379	Dec 2009	Morishita	
	U 0333	5949973	Sept 1999	Yarom	
	U 0334	8400566	Mar. 2013	Terry	
	U 0335	5649284	July 1997	Yoshinobu	
	U 0336	7444506	Oct 2008	Datta	
	U 0337	6480963	Oct 2002	Tachibana	November 12, 2002
	U 0338	6510513	Jan 2003	Darrew	Danieli
	U 0339	5189411	Feb 1993	Collar	
	U 0340	5293633	Mar 1994	Robbins	
	U 0341	4633462	Dec 1986	Stifle	
	U 0342	5103461	Mar 1992	Cain	Tymes April 7, 1992
	U 0343	6272535	Aug 2001	Iwamura	

DATE:	EXAMINER'S SIGNATURE:
-------	-----------------------

ALL REFERENCES CONSIDERED EXCEPT WHERE LINED THROUGH. //I.O./

Receipt date: 03/20/2015

11895388 - GAU: 2432

Printed: March 20, 2015 (12:02pm)

Path: Y:\Clients\SCOT Scott A Moskowitz and Wistaria Trading, Inc\SCOT0014-4\Drafts\ReferenceCitationList_SCOT0014-4_3-12-2015.wpd

37 CFR 1.98(a)(1)(i) APPLICATION & ATTORNEY DOCKET: 11/895,388 / SCOT0014-4

37 CFR 1.98(a)(1)(iii): THIS IS AN INFORMATION DISCLOSURE STATEMENT

Change(s) applied to document, /D.D./ 6/27/2015

07-2010

EXAMINER INITIALS	REFERENCE NUMBER (U SERIES)	PATENT NUMBER	ISSUE DATE	NAME OF PATENTEE OR APPLICANT	REFERENCES CITED AND CONSIDERED BY EXAMINER IN PARENT CASE IDENTIFIED BY PLACEMENT OF "X"
	U 0298	6590996	Jun 2003	Reed	X
	U 0299	5949055	Sept 1999	Fleet	X
	U 0300	6067622	May 2000	Moore	X
	U 0301	7761712	Jun 2010	Moskowitz	X
	U 0302	7743001	Jun 2010	Vermeulen	X
	U 0303	6865747	Mar 2005	Mercier	
	U 0304	6611599	Aug 2003	Natarajan	
	U 0305	6480937	Nov 2002	Vorbach	
	U 0306	6398245	Jun 2002	Gruse	
	U 0307	6950941	Sept 2005	Lee	
	U 0308	6983058	Jan 2006	Fukuoka	
	U 0309	5675653	Oct 1997	Nelson	
	U 0310	6804453	Oct 2004	Sasamoto	
	U 0311	6178405	Jan 2001	Ouyang	
	U 0312	5839100	Nov 1998	Wegener	
	U 0313	5781184	Jul 1998	Wasserman	
	U 0314	5617506	Apr 1997	Burk	
	U 0315	5327520	Jul 1994	Chen	
	U 0316	5111530	May 1992	Kutaragi	
	U 0317	7095715	Aug 2006	Buckman	
	U 0318	6173322	Jan 2001	Hu	
	U 0319	5754938	May 1998	Herz	
	U 0320	6035398	Mar 2000	Bjorn	

DATE:	EXAMINER'S SIGNATURE:
-------	-----------------------

ALL REFERENCES CONSIDERED EXCEPT WHERE LINED THROUGH. //I.O./

Receipt date: 03/20/2015

11895388 - GAU: 2432

Printed: March 20, 2015 (12:02pm)

Path: Y:\Clients\SCOT Scott A Moskowitz and Wistaria Trading,

Inc\SCOT0014-4\Drafts\ReferenceCitationList_SCOT0014-4_3-12-2015.wpd

37 CFR 1.98(a)(1)(i) APPLICATION & ATTORNEY DOCKET: 11/895,388 / SCOT0014-4

37 CFR 1.98(a)(1)(iii): THIS IS AN INFORMATION DISCLOSURE STATEMENT

EXAMINER INITIALS	REFERENCE NUMBER (U SERIES)	PATENT NUMBER	ISSUE DATE	NAME OF PATENTEE OR APPLICANT	REFERENCES CITED AND CONSIDERED BY EXAMINER IN PARENT CASE IDENTIFIED BY PLACEMENT OF "X"
	U 0275	7457962	November 2008	Moskowitz	X
	U 0276	7460994	December 2008	Herre et al.	X
	U 0277	7475246	January 2009	Moskowitz	X
	U 0278	7530102	May 2009	Moskowitz	X
	U 0279	7532725	May 2009	Moskowitz et al.	X
	U 0280	7568100	July 2009	Moskowitz et al.	X
	U 0281	7647502	January 2010	Moskowitz	X
	U 0282	7647503	January 2010	Moskowitz	X
	U 0283	7779261	August 2010	Moskowitz	X
	U 0284	6990453	January 2006	Wang	X
	U 0285	6081597	June 2000	Hoffstein	X
	U 0286	7035049	Apr 2006	Yamamoto	X
	U 0287	7664263	Feb 2010	Moskowitz	X
	U 0288	7286451	Oct 2007	Wirtz	X
	U 0289	6385324	May 2002	Koppen	X
	U 0290	6674858	Jan 2004	Kimura	X
	U 0291	6148333	Nov 2000	Guedalia	X
	U 0292	6418421	Jan 2002	Hurtado	X
	U 0293	6385596	May 2002	Wiser	X
	U 0294	6226618	May 2001	Downs	X
	U 0295	6957330	Oct 2005	Hughes	X
	U 0296	5842213	Nov 1998	Odom	X
	U 0297	5818818	Oct 1998	Soumiya	X

Change(s) applied to document, /D.D./ 6/27/2015

July 9, 2002

DATE:	EXAMINER'S SIGNATURE:
-------	-----------------------

ALL REFERENCES CONSIDERED EXCEPT WHERE LINED THROUGH. //I.O./

Receipt date: 03/20/2015

11895388 - GAU: 2432

Printed: March 20, 2015 (12:02pm)

Path: Y:\Clients\SCOT Scott A Moskowitz and Wistaria Trading,

Inc\SCOT0014-4\Drafts\ReferenceCitationList_SCOT0014-4_3-12-2015.wpd

37 CFR 1.98(a)(1)(i) APPLICATION & ATTORNEY DOCKET: 11/895,388 / SCOT0014-4

37 CFR 1.98(a)(1)(iii): THIS IS AN INFORMATION DISCLOSURE STATEMENT

EXAMINER INITIALS	REFERENCE NUMBER (U SERIES)	PATENT NUMBER	ISSUE DATE	NAME OF PATENTEE OR APPLICANT	REFERENCES CITED AND CONSIDERED BY EXAMINER IN PARENT CASE IDENTIFIED BY PLACEMENT OF "X"
	U 0229	6799277	September 2004	Colvin	X
	U 0230	6813717	November 2004	Colvin	X
	U 0231	6813718	November 2004	Colvin	X
	U 0232	6823455	November 2004	Macy et al.	X
	U 0233	6834308	December 2004	Ikezoye et al.	X
	U 0234	6842862	January 2005	Chow et al.	X
	U 0235	6853726	February 2005	Moskowitz et al.	X
	U 0236	6857078	February 2005	Colvin	X
	U 0237	6931534	August 2005	Jandel et al.	X
	U 0238	6966002	November 2005	Torrubia-Saez	X
	U 0239	6983337	November 2005	Wold	X
	U 0240	6977894	December 2005	Achilles et al.	X
	U 0241	6978370	December 2005	Kocher	X
	U 0242	6986063	January 2006	Colvin	X
	U 0243	7007166	February 2006	Moskowitz et al.	X
	U 0244	7020285	March 2006	Kirovski et al.	X
	U 0245	7035409	April 2006	Moskowitz	X
	U 0246	7043050	May 2006	Yuval	X
	U 0247	7046808	May 2006	Metois et al.	X
	U 0248	7050396	May 2006	Cohen et al.	X
	U 0249	7051208	May 2006	Venkatesan et al.	X
	U 0250	7058570	June 2006	Yu et al.	X
	U 0251	7093295	August 2006	Saito	X

Change(s) applied to document, /D.D./ 6/27/2015

6,968,337

DATE:	EXAMINER'S SIGNATURE:
-------	-----------------------

ALL REFERENCES CONSIDERED EXCEPT WHERE LINED THROUGH. //I.O./

Printed: November 19, 2010 (12:45pm)

Path: Y:\Clients\SCOT Scott A Moskowitz and Wistaria Trading, Inc\SCOT0014-4\Drafts\IDS_SCOT00014-4_11-19-2010.wpd

37 CFR 1.98(a)(1)(i) APPLICATION:

37 CFR 1.98(a)(1)(iii): THIS IS AN INFORMATION DISCLOSURE STATEMENT

EXAMINER INITIALS	REF. NO. (L series)	REFERENCE NUMBER (L Series)	PUB. DATE	INCLUDE IN SEQUENCE: Name of first author (in CAPITAL LETTERS), Title in quotation marks, name of publication, date or publication, page numbers, publisher, city of publication, and country of publication NOTE - For US patent applications listed herein, if a publication of the application is identified, Applicant is citing the listed publication and not submitting a copy of the cited application as filed. The examiner is invited to inspect the IFW as desired to view any application as filed.	ENGLISH LANGUAGE TRANSLATION ATTACHED? (YES OR NO) AND/OR OR IDENTIFICATION OF PRIORITY APPLICATION IN WHICH REFERENCE IS CITED
	201	L- 0201	N/A	US Provisional Application 60/222,023 filed July 31, 2007 entitled "Method and apparatus for recognizing sound and signals in high noise and distortion"	
	202	L- 0202	N/A	US Application 11/458,639 filed July 19, 2006 entitled "Methods and Systems for Inserting Watermarks in Digital Signals", published as 2006-0251291 A1 11-09-2006. Rhoads; Geoffrey B.	
	203	L- 0203	1995	"Techniques for Data Hiding in Audio Files," by Morimoto, 1995	
	204	L- 0204	1998	Howe, Dennis July 13, 1998 http://foldoc.org/steganography	
	205	L- 0205	N/A	CSG, Computer Support Group and CSGNetwork.com 1973 http://www.csgnetwork.com/glossarys.html	
	206	L- 0206	2010	QuinStreet Inc. 2010 What is steganography?-A word definition from the Webopedia Computer Dictionary http://www.webopedia.com/terms/steganography.html	
	207	L- 0207	2000	Graham, Robert August 21, 2000 "Hacking Lexicon" http://robertgraham.com/pubs/hacking-dict.html	

Change(s) applied

to document,

/D.D./

6/27/2015

DATE: 03/17/2011	EXAMINER'S SIGNATURE: /Izunna Okeke/
------------------	--------------------------------------

ALL REFERENCES CONSIDERED EXCEPT WHERE LINED THROUGH. //I.O./

Printed: November 19, 2010 (12:45pm)

Path: Y:\Clients\SCOT Scott A Moskowitz and Wistaria Trading, Inc\SCOT0014-4\Drafts\IDS_SCOT00014-4_11-19-2010.wpd

37 CFR 1.98(a)(1)(i) APPLICATION:

37 CFR 1.98(a)(1)(iii): THIS IS AN INFORMATION DISCLOSURE STATEMENT

Change(s) applied
to document
/D.D./
6/27/2015

EXAMINER INITIALS	REF. NO. (L series)	REFERENCE NUMBER (L Series)	PUB. DATE	INCLUDE IN SEQUENCE: Name of first author (in CAPITAL LETTERS), Title in quotation marks, name of publication, date or publication, page numbers, publisher, city of publication, and country of publication NOTE - For US patent applications listed herein, if a publication of the application is identified, Applicant is citing the listed publication and not submitting a copy of the cited application as filed. The examiner is invited to inspect the IFW as desired to view any application as filed.	ENGLISH LANGUAGE TRANSLATION ATTACHED? (YES OR NO) AND/OR OR IDENTIFICATION OF PRIORITY APPLICATION IN WHICH REFERENCE IS CITED
	185	L- 0185	N/A	U.S. Appl. No. 12/665,002, filed Dec. 22, 2009, entitled "Method for Combining Transfer Function with Predetermined Key Creation", published as 2010-0182570 A1 07-22-2010. Matsumoto; Chota; et al.	
	186	L- 0186	N/A	U.S. Appl. No. 12/592,331, filed Nov. 23, 2009, entitled "Optimization Methods for the Insertion, Protection, and Detection of Digital Watermarks in Digital Data", published as 2010-0077220 A1 03-25-2010.	Moskowitz; Scott A.
	187	L- 0187	N/A	U.S. Appl. No. 12/590,553, filed Nov. 10, 2009, entitled "Optimization Methods for the Insertion, Protection, and Detection of Digital Watermarks in Digital Data", published as 2010-0077219 A1 03-25-2010.	Moskowitz; Scott A.
	188	L- 0188	N/A	U.S. Appl. No. 12/590,681, filed Nov. 12, 2009, entitled "Optimization Methods for the Insertion, Protection, and Detection of Digital Watermarks in Digital Data", published as 2010-0064140 A1 03-11-2010.	Moskowitz; Scott A.
	189	L- 0189	N/A	U.S. Appl. No. 12/655,036, filed Dec. 22, 2009, entitled "Utilizing Data Reduction in Steganographic and Cryptographic Systems", published as 2010-0153734 A1 06-17-2010.	Moskowitz; Scott A.; et al.
	190	L- 0190	N/A	U.S. Appl. No. 12/655,357, filed Dec. 22, 2009, entitled "Method And Device For Monitoring And Analyzing Signals", published as 2010-0106736 A1 04-29-2010.	Moskowitz; Scott A.; et al.

DATE: 03/17/2011	EXAMINER'S SIGNATURE: /Izunna Okeke/
------------------	--------------------------------------

ALL REFERENCES CONSIDERED EXCEPT WHERE LINED THROUGH. /I.O./

Printed: November 19, 2010 (12:45pm)

Path: Y:\Clients\SCOT Scott A Moskowitz and Wistaria Trading, Inc\SCOT0014-4\Drafts\IDS_SCOT00014-4_11-19-2010.wpd

37 CFR 1.98(a)(1)(i) APPLICATION:

37 CFR 1.98(a)(1)(iii): THIS IS AN INFORMATION DISCLOSURE STATEMENT

Change(s) applied to document, /D.D./ 6/27/2015

EXAMINER INITIALS	REF. NO. (L series)	REFERENCE NUMBER (L Series)	PUB. DATE	INCLUDE IN SEQUENCE: Name of first author (in CAPITAL LETTERS), Title in quotation marks, name of publication, date or publication, page numbers, publisher, city of publication, and country of publication NOTE - For US patent applications listed herein, if a publication of the application is identified, Applicant is citing the listed publication and not submitting a copy of the cited application as filed. The examiner is invited to inspect the IFW as desired to view any application as filed.	ENGLISH LANGUAGE TRANSLATION ATTACHED? (YES OR NO) AND/OR OR IDENTIFICATION OF PRIORITY APPLICATION IN WHICH REFERENCE IS CITED
	35	L- 035	N/A	U.S. Appl. No. 11/647,861, filed Dec. 29, 2006, entitled "System and Methods for Permitting Open Access to Data Objects and for Securing Data within the Data Objects", published as 2007-0110240 A1 05-17-2007.	Moskowitz; Scott A.; et al.
	36	L- 036	1996	Schneier, Bruce, Applied Cryptography, 2nd Ed., John Wiley & Sons, pp. 9-10, 1996.	
	37	L- 037	1997	Menezes, Alfred J., Handbook of Applied Cryptography, CRC Press, p. 46, 1997.	
	38	L- 038	1997	Merriam-Webster's Collegiate Dictionary, 10th Ed., Merriam Webster, Inc., p. 207.	
	39	L- 039	1984	Brealy, et al., Principles of Corporate Finance, "Appendix A--Using Option Valuation Models", 1984, pp. 448-449.	
	40	L- 040	2001	Copeland, et al., Real Options: A Practitioner's Guide, 2001 pp. 106-107, 201-202, 204-208.	
	41	L- 041	1995	Sarkar, M. "An Assessment of Pricing Mechanisms for the Internet-A Regulatory Imperative", presented MIT Workshop on Internet Economics, Mar. 1995 http://www.press.vmich.edu/iep/works/SarkAsses.html	

DATE: 03/17/2011	EXAMINER'S SIGNATURE: /Izunna Okeke/
------------------	--------------------------------------

ALL REFERENCES CONSIDERED EXCEPT WHERE LINED THROUGH. /I.O./

Printed: November 19, 2010 (12:45pm)

Path: Y:\Clients\SCOT Scott A Moskowitz and Wistaria Trading, Inc\SCOT0014-4\Drafts\IDS_SCOT00014-4_11-19-2010.wpd

37 CFR 1.98(a)(1)(i) APPLICATION:

37 CFR 1.98(a)(1)(iii): THIS IS AN INFORMATION DISCLOSURE STATEMENT

Change(s) applied to document, /D.D./ 6/27/2015

EXAMINER INITIALS	REF. NO. (L series)	REFERENCE NUMBER (L Series)	PUB. DATE	INCLUDE IN SEQUENCE: Name of first author (in CAPITAL LETTERS), Title in quotation marks, name of publication, date or publication, page numbers, publisher, city of publication, and country of publication NOTE - For US patent applications listed herein, if a publication of the application is identified, Applicant is citing the listed publication and not submitting a copy of the cited application as filed. The examiner is invited to inspect the IFW as desired to view any application as filed.	ENGLISH LANGUAGE TRANSLATION ATTACHED? (YES OR NO) AND/OR OR IDENTIFICATION OF PRIORITY APPLICATION IN WHICH REFERENCE IS CITED
	29	L- 029	N/A	U.S. Appl. No. 10/805,484, filed Mar. 22, 2004, entitled "Method And Device For Monitoring And Analyzing Signals", published as 2004-0243540 A1 12-02-2004.	Moskowitz, Scott A.; et al.
	30	L- 030	N/A	U.S. Appl. No. 09/956,262, filed Sep. 20, 2001, entitled "Improved Security Based on Subliminal and Supraliminal Channels For Data Objects", published as 2002-0056041 A1 05-09-2002	Moskowitz, Scott A.
	31	L- 031	N/A	U.S. Appl. No. 11/518,806, filed Sep. 11, 2006, entitled "Improved Security Based on Subliminal and Supraliminal Channels For Data Objects", 2008-0028222 A1 01-31-2008 .	Moskowitz, Scott A.
	32	L- 032	N/A	U.S. Appl. No. 11/026,234, filed Dec. 30, 2004, entitled "Z-Transform Implementation of Digital Watermarks", published as 2005-0135615 A1 06-23-2005.	Moskowitz, Scott A.; et al.
	33	L- 033	N/A	U.S. Appl. No. 11/592,079, filed Nov. 2, 2006, entitled "Linear Predictive Coding Implementation of Digital Watermarks", published as 2007-0079131 A1 04-05-2007.	Moskowitz, Scott A.; et al.
	34	L- 034	N/A	U.S. Appl. No. 09/731,039, filed Dec. 7, 2000, entitled "System and Methods for Permitting Open Access to Data Objects and for Securing Data within the Data Objects", published as 2002-0071556 A1 06-13-2002	Moskowitz, Scott A.; et al.

DATE: 03/17/2011	EXAMINER'S SIGNATURE: /Izunna Okeke/
------------------	--------------------------------------

ALL REFERENCES CONSIDERED EXCEPT WHERE LINED THROUGH. //I.O./

Printed: November 19, 2010 (12:45pm)

Path: Y:\Clients\SCOT Scott A Moskowitz and Wistaria Trading, Inc\SCOT0014-4\Drafts\IDS_SCOT00014-4_11-19-2010.wpd

37 CFR 1.98(a)(1)(i) APPLICATION:

37 CFR 1.98(a)(1)(iii): THIS IS AN INFORMATION DISCLOSURE STATEMENT

EXAMINER INITIALS	REF. NO. (L series)	REFERENCE NUMBER (L Series)	PUB. DATE	INCLUDE IN SEQUENCE: Name of first author (in CAPITAL LETTERS), Title in quotation marks, name of publication, date or publication, page numbers, publisher, city of publication, and country of publication NOTE - For US patent applications listed herein, if a publication of the application is identified, Applicant is citing the listed publication and not submitting a copy of the cited application as filed. The examiner is invited to inspect the IFW as desired to view any application as filed.	ENGLISH LANGUAGE TRANSLATION ATTACHED? (YES OR NO) AND/OR OR IDENTIFICATION OF PRIORITY APPLICATION IN WHICH REFERENCE IS CITED
	23	L- 023	N/A	U.S. Appl. No. 11/519,467, filed Sep. 12, 2006, entitled "Utilizing Data Reduction in Steganographic and Cryptographic Systems", published as 2007-0064940 A1 03-22-2007.	Moskowitz, Scott A.; et al.
	24	L- 024	N/A	U.S. Appl. No. 09/731,040, filed Dec. 7, 2000, entitled "Systems, Methods And Devices For Trusted Transactions", 2002-0010684 A1 01-24-2002.	Moskowitz, Scott A.
	25	L- 025	N/A	U.S. Appl. No. 11/512,701, filed Aug. 29, 2006, entitled "Systems, Methods And Devices For Trusted Transactions", published as 2007-0028113 A1 02-01-2007.	Moskowitz, Scott A.
	26	L- 026	N/A	U.S. Appl. No. 10/049,101, filed Feb. 8, 2002, entitled "A Secure Personal Content Server", published as 7,475,246 01-06-2009.	Moskowitz, et al.
	27	L- 027	N/A	PCT Application No. PCT/US00/21189, filed Aug. 4, 2000, entitled, "A Secure Personal Content Server", Pub. No.: WO018628 ; Publication Date: 15.03.2001, F21 here in above.	
	28	L- 028	N/A	U.S. Appl. No. 09/657,181, filed Sep. 7, 2000, entitled "Method and Device For Monitoring And Analyzing Signals", published as 7,346,472 03-18-2008.	Moskowitz, et al.

Change(s) applied to document /D.D./ 6/27/2015

DATE: 03/17/2011	EXAMINER'S SIGNATURE: /Izunna Okeke/
------------------	--------------------------------------

ALL REFERENCES CONSIDERED EXCEPT WHERE LINED THROUGH. //I.O./

Printed: November 19, 2010 (12:45pm)

Path: Y:\Clients\SCOT Scott A Moskowitz and Wistaria Trading, Inc\SCOT0014-4\Drafts\IDS_SCOT00014-4_11-19-2010.wpd

37 CFR 1.98(a)(1)(i) APPLICATION:

37 CFR 1.98(a)(1)(iii): THIS IS AN INFORMATION DISCLOSURE STATEMENT

EXAMINER INITIALS	REF. NO. (L series)	REFERENCE NUMBER (L Series)	PUB. DATE	INCLUDE IN SEQUENCE: Name of first author (in CAPITAL LETTERS), Title in quotation marks, name of publication, date or publication, page numbers, publisher, city of publication, and country of publication NOTE - For US patent applications listed herein, if a publication of the application is identified, Applicant is citing the listed publication and not submitting a copy of the cited application as filed. The examiner is invited to inspect the IFW as desired to view any application as filed.	ENGLISH LANGUAGE TRANSLATION ATTACHED? (YES OR NO) AND/OR OR IDENTIFICATION OF PRIORITY APPLICATION IN WHICH REFERENCE IS CITED
	18	L- 018	N/A	U.S. Appl. No. 11/599,964, filed Nov. 15, 2006, entitled "Optimization Methods for the Insertion, Protection, and Detection of Digital Watermarks in Digital Data", published as 2008-0046742 A1 02-21-2008.	Moskowitz, Scott A.
	19	L- 019	N/A	U.S. Appl. No. 11/599,838, filed Nov. 15, 2006, entitled "Optimization Methods for the Insertion, Protection, and Detection of Digital Watermarks in Digital Data", published as 2007-0226506 A1 09-27-2007	Moskowitz, Scott A.
	20	L- 020	N/A	U.S. Appl. No. 10/369,344, filed Feb. 18, 2003, entitled "Optimization Methods for the Insertion, Protection, and Detection of Digital Watermarks in Digitized Data", published as 2003-0219143 A1 11-27-2003.	Moskowitz, Scott A.; et al.
	21	L- 021	N/A	U.S. Appl. No. 11/482,654, filed Jul. 7, 2006, entitled "Optimization Methods for the Insertion, Protection, and Detection of Digital Watermarks in Digitized Data", published as 2006-0285722 A1 12-21-2006.	Moskowitz, Scott A.; et al.
	22	L- 022	N/A	U.S. Appl. No. 09/594,719, filed Jun. 16, 2000, entitled "Utilizing Data Reduction in Steganographic and Cryptographic Systems", published as 7,123,718 10-17-2006 .	Moskowitz, et al.

Change(s) applied to document, /D.D./ 6/27/2015

DATE: 03/17/2011	EXAMINER'S SIGNATURE: /Izunna Okeke/
------------------	--------------------------------------

ALL REFERENCES CONSIDERED EXCEPT WHERE LINED THROUGH. //I.O./

Printed: November 19, 2010 (12:45pm)

Path: Y:\Clients\SCOT Scott A Moskowitz and Wistaria Trading, Inc\SCOT0014-4\Drafts\IDS_SCOT00014-4_11-19-2010.wpd

37 CFR 1.98(a)(1)(i) APPLICATION:

37 CFR 1.98(a)(1)(iii): THIS IS AN INFORMATION DISCLOSURE STATEMENT

Change(s) applied
to document,
/D.D./
6/27/2015

EXAMINER INITIALS	REF. NO. (L series)	REFERENCE NUMBER (L Series)	PUB. DATE	INCLUDE IN SEQUENCE: Name of first author (in CAPITAL LETTERS), Title in quotation marks, name of publication, date or publication, page numbers, publisher, city of publication, and country of publication NOTE - For US patent applications listed herein, if a publication of the application is identified, Applicant is citing the listed publication and not submitting a copy of the cited application as filed. The examiner is invited to inspect the IFW as desired to view any application as filed.	ENGLISH LANGUAGE TRANSLATION ATTACHED? (YES OR NO) AND/OR OR IDENTIFICATION OF PRIORITY APPLICATION IN WHICH REFERENCE IS CITED
	13	L- 013	N/A	U.S. Appl. No. 09/767,733, filed Jan. 24, 2001, entitled "Multiple Transform Utilization and Application for Secure Digital Watermarking", published as 2001-0010078 A1 07-26-2001.	Moskowitz, Scott A.
	14	L- 014	N/A	U.S. Appl. No. 11/358,874, filed Feb. 21, 2006, entitled "Multiple Transform Utilization and Application for Secure Digital Watermarking", published as 2006-0140403 A1 06-29-2006	Moskowitz; Scott A.
	15	L- 015	N/A	U.S. Appl. No. 10/417,231, filed Apr. 17, 2003, entitled "Methods, Systems And Devices For Packet Watermarking And Efficient Provisioning Of Bandwidth", published as 2003-0200439 A1 10-23-2003	Moskowitz, Scott A.
	16	L- 016	N/A	U.S. Appl. No. 09/789,711, filed Feb. 22, 2001, entitled "Optimization Methods for the Insertion, Protection, and Detection of Digital Watermarks in Digital Data", published as 2001-0029580 A1 10-11-2001.	Moskowitz, Scott A.
	17	L- 017	N/A	U.S. Appl. No. 11/497,822, filed Aug. 2, 2006, entitled "Optimization Methods for the Insertion, Protection, and Detection of Digital Watermarks in Digital Data", published as 2007-0011458 A1 01-11-2007	Moskowitz; Scott A.

DATE: 03/17/2011	EXAMINER'S SIGNATURE: /Izunna Okeke/
------------------	--------------------------------------

ALL REFERENCES CONSIDERED EXCEPT WHERE LINED THROUGH. //I.O./

Printed: November 19, 2010 (12:45pm)

Path: Y:\Clients\SCOT Scott A Moskowitz and Wistaria Trading, Inc\SCOT0014-4\Drafts\IDS_SCOT00014-4_11-19-2010.wpd

37 CFR 1.98(a)(1)(i) APPLICATION:

37 CFR 1.98(a)(1)(iii): THIS IS AN INFORMATION DISCLOSURE STATEMENT

Change(s) applied
to document,
/D.D./
6/27/2015

EXAMINER INITIALS	REF. NO. (L series)	REFERENCE NUMBER (L Series)	PUB. DATE	INCLUDE IN SEQUENCE: Name of first author (in CAPITAL LETTERS), Title in quotation marks, name of publication, date or publication, page numbers, publisher, city of publication, and country of publication NOTE - For US patent applications listed herein, if a publication of the application is identified, Applicant is citing the listed publication and not submitting a copy of the cited application as filed. The examiner is invited to inspect the IFW as desired to view any application as filed.	ENGLISH LANGUAGE TRANSLATION ATTACHED? (YES OR NO) AND/OR OR IDENTIFICATION OF PRIORITY APPLICATION IN WHICH REFERENCE IS CITED
	7	L- 07	N/A	U.S. Appl. No. 11/649,026, filed Jan. 3, 2007, entitled "Method and System for Digital Watermarking", published as 2007-0113094 A1 05-17-2007.	Moskowitz, Scott A.; et al.
	8	L- 08	N/A	U.S. Appl. No. 09/046,627, filed Mar. 24, 1998, entitled "Method for Combining Transfer Function with Predetermined Key Creation", published as 6,598,162 07-22-2003 .	Moskowitz
	9	L- 09	N/A	U.S. Appl. No. 10/602,777, filed Jun. 25, 2003, entitled "Method for Combining Transfer Function with Predetermined Key Creation", published as 2004-0086119 A1 05-06-2004	Moskowitz, Scott A.
	10	L- 010	N/A	U.S. Appl. No. 09/053,628, filed Apr. 2, 1998, entitled "Multiple Transform Utilization and Application for Secure Digital Watermarking", 6,205,249 03-20-2001	Moskowitz
	11	L- 011	N/A	U.S. Appl. No. 09/644,098, filed Aug. 23, 2000, entitled "Multiple Transform Utilization and Application for Secure Digital Watermarking", published as 7,035,409 04-25-2006	Moskowitz
	12	L- 012	N/A	Jap. App. No. 2000-542907, entitled "Multiple Transform Utilization and Application for Secure Digital Watermarking", JP national stage of PCT/US1999/007262, published as WO99052271, 10/14/1999, F13 here in above.	

DATE: 03/17/2011	EXAMINER'S SIGNATURE: /Izunna Okeke/
------------------	--------------------------------------

ALL REFERENCES CONSIDERED EXCEPT WHERE LINED THROUGH. /I.O./

Printed: November 19, 2010 (12:45pm)

Path: Y:\Clients\SCOT Scott A Moskowitz and Wistaria Trading, Inc\SCOT0014-4\Drafts\IDS_SCOT00014-4_11-19-2010.wpd

37 CFR 1.98(a)(1)(i) APPLICATION:

37 CFR 1.98(a)(1)(iii): THIS IS AN INFORMATION DISCLOSURE STATEMENT

LISTING OF NON PATENT LITERATURE - O Series

Change(s) applied
to document
/D.D./
6/27/2015

EXAMINER INITIALS	REF. NO. (L series)	REFERENCE NUMBER (L Series)	PUB. DATE	INCLUDE IN SEQUENCE: Name of first author (in CAPITAL LETTERS), Title in quotation marks, name of publication, date or publication, page numbers, publisher, city of publication, and country of publication NOTE - For US patent applications listed herein, if a publication of the application is identified, Applicant is citing the listed publication and not submitting a copy of the cited application as filed. The examiner is invited to inspect the IFW as desired to view any application as filed.	ENGLISH LANGUAGE TRANSLATION ATTACHED? (YES OR NO) AND/OR OR IDENTIFICATION OF PRIORITY APPLICATION IN WHICH REFERENCE IS CITED
	1	L- 01	7/28/2009	US. Appl. No. 08/999,766, filed Jul. 23, 1997, entitled "Steganographic Method and Device", published as 7,568,100 07-28-2009.	Moskowitz, et al.
	2	L- 02	N/A	EPO Application No. 96919405.9, entitled "Steganographic Method and Device"; published as EP0872073 (A2), published 10-21-1998.	
	3	L- 03	8/11/2005	U.S. Appl. No. 11/050,779, filed Feb. 7, 2005, entitled "Steganographic Method and Device", published as 20050177727 A1 08-11-2005. Moskowitz, Scott A.; et al.	
	4	L- 04	4/22/2008	U.S. Appl. No. 08/674,726, filed Jul. 2, 1996, entitled "Exchange Mechanisms for Digital Information Packages with Bandwidth Securitization, Multichannel Digital Watermarks, and Key Management", published as 7,362,775 04-22-2008 .	Moskowitz
	5	L- 05	N/A	U.S. Appl. No. 09/545,589, filed Apr. 7, 2000, entitled "Method and System for Digital Watermarking", published as 7,007,166 02-28-2006	Moskowitz, et al.
	6	L- 06	N/A	U.S. Appl. No. 11/244,213, filed Oct. 5, 2005, entitled "Method and System for Digital Watermarking", published as 2006-0101269 A1 05-11-2006	Moskowitz; Scott A.; et al.

DATE: 03/17/2011	EXAMINER'S SIGNATURE: /Izunna Okeke/
------------------	--------------------------------------

ALL REFERENCES CONSIDERED EXCEPT WHERE LINED THROUGH. /I.O./

Receipt date: 11/19/2010

11895388 - GAU: 2432

Printed: November 19, 2010 (12:45pm)

Path: Y:\Clients\SCOT Scott A Moskowitz and Wistaria Trading, Inc\SCOT0014-4\Drafts\IDS_SCOT00014-4_11-19-2010.wpd

37 CFR 1.98(a)(1)(i) APPLICATION:

37 CFR 1.98(a)(1)(iii): THIS IS AN INFORMATION DISCLOSURE STATEMENT

EXAMINER INITIALS	REFERENCE NUMBER (P SERIES)	PUBLICATION NUMBER	PUBLICATION DATE	NAME OF PATENTEE OR APPLICANT	PAGE/LINE AND FIGURE/ELEMENT OF RELEVANT MATERIAL AND/OR IDENTIFICATION OF PRIORITY APPLICATION IN WHICH REFERENCE CITED
	P 064	20090089427	April 2009	Moskowitz et al.	
	P 065	20090190754	July 2009	Moskowitz et al.	
	P 066	20090210711	August 2009	Moskowitz	
	P 067	20090220074	September 2009	Moskowitz et al.	
	P 068	20100002904	January 2010	Moskowitz	
	P 069	20100005308	January 2010	Moskowitz	
	P 070	20100098251	Apr 2010	Moskowitz	
	P 071	20100220861	Sept 2010	Moskowitz	
	P 072	20100202607	Aug 2010	Moskowitz	
	P 073	20020047873	June 2002	Petrovic	20020097873
	P 074	20020009208	Jan 2002	Alattar	
	P 075	20010029580	October 2001	Moskowitz	
	P 076	20100182570	July 2010	Chote	Matsumoto ; et al.
	P 077	20100077220	March 2010	Moskowitz	
	P 078	20100077219	March 2010	Moskowitz	
	P 079	20100064140	March 2010	Moskowitz	
	P 080	20100153734	June 2010	Moskowitz	
	P 081	20100106736	April 2010	Moskowitz	
	P 082	20060251291	November 2006	Rhoads	

Change(s) applied to document, /D.D./ 6/27/2015

07-2002

DATE: 03/17/2011	EXAMINER'S SIGNATURE: /Izunna Okeke/
------------------	--------------------------------------

ALL REFERENCES CONSIDERED EXCEPT WHERE LINED THROUGH. /I.O./

Receipt date: 11/19/2010

11895388 - GAU: 2432

Printed: November 19, 2010 (12:45pm)

Path: Y:\Clients\SCOT Scott A Moskowitz and Wistaria Trading, Inc\SCOT0014-4\Drafts\IDS_SCOT00014-4_11-19-2010.wpd

37 CFR 1.98(a)(1)(i) APPLICATION:

37 CFR 1.98(a)(1)(iii): THIS IS AN INFORMATION DISCLOSURE STATEMENT

EXAMINER INITIALS	REFERENCE NUMBER (U SERIES)	PATENT NUMBER	ISSUE DATE	NAME OF PATENTEE OR APPLICANT	PAGE/LINE AND FIGURE/ELEMENT OF RELEVANT MATERIAL AND/OR IDENTIFICATION OF PRIORITY APPLICATION IN WHICH REFERENCE IS CITED
	U 0291	6148333	Nov 2000	Guedalia	
	U 0292	6418421	Jun 2002	Hurtado	
	U 0293	6385596	May 2002	Wiser	
	U 0294	6226618	May 2001	Downs	
	U 0295	6957330	Oct 2005	Hughes	
	U 0296	5842213	Nov 1998	Odom	
	U 0297	5818818	Oct 1998	Soumiya	
	U 0298	6590996	Jun 2003	Reed	
	U 0299	5949055	Sept 1999	Fleet	
	U 0300	6067622	May 2000	Moore	
	U 0301	7761712	Jun 2010	Moskowitz	July 20, 2010
	U 0302	7743001	Jun 2010	Vermeulen	

Change(s) applied to document,

/D.D./
6/27/2015

DATE: 03/17/2011	EXAMINER'S SIGNATURE: /Izunna Okeke/
------------------	--------------------------------------

ALL REFERENCES CONSIDERED EXCEPT WHERE LINED THROUGH. //I.O./

Printed: November 19, 2010 (12:45pm)

Path: Y:\Clients\SCOT Scott A Moskowitz and Wistaria Trading, Inc\SCOT0014-4\Drafts\IDS_SCOT00014-4_11-19-2010.wpd

37 CFR 1.98(a)(1)(i) APPLICATION:

37 CFR 1.98(a)(1)(iii): THIS IS AN INFORMATION DISCLOSURE STATEMENT

EXAMINER INITIALS	REFERENCE NUMBER (U SERIES)	PATENT NUMBER	ISSUE DATE	NAME OF PATENTEE OR APPLICANT	PAGE/LINE AND FIGURE/ELEMENT OF RELEVANT MATERIAL AND/OR IDENTIFICATION OF PRIORITY APPLICATION IN WHICH REFERENCE IS CITED
	U 0228	6795925	September 2004	Colvin	
	U 0229	6799277	September 2004	Colvin	
	U 0230	6813717	November 2004	Colvin	
	U 0231	6813718	November 2004	Colvin	
	U 0232	6823455	November 2004	Macy et al.	
	U 0233	6834308	December 2004	Ikezoye et al.	
	U 0234	6842862	January 2005	Chow et al.	
	U 0235	6853726	February 2005	Moskowitz et al.	
	U 0236	6857078	February 2005	Colvin	
	U 0237	6931534	August 2005	Jandel et al.	
	U 0238	6966002	November 2005	Torrubia-Saez	
	U 0239	6983337	November 2005	Wold	6,968,337
	U 0240	6977894	December 2005	Achilles et al.	
	U 0241	6978370	December 2005	Kocher	
	U 0242	6986063	January 2006	Colvin	
	U 0243	7007166	February 2006	Moskowitz et al.	
	U 0244	7020285	March 2006	Kirovski et al.	
	U 0245	7035409	April 2006	Moskowitz	
	U 0246	7043050	May 2006	Yuval	
	U 0247	7046808	May 2006	Metois et al.	
	U 0248	7050396	May 2006	Cohen et al.	

Change(s) applied to document, /D.D./ 6/27/2015

DATE: 03/17/2011	EXAMINER'S SIGNATURE: /Izunna Okeke/
------------------	--------------------------------------

ALL REFERENCES CONSIDERED EXCEPT WHERE LINED THROUGH. /I.O./

Receipt date: 09/08/2009

11895388 - GAU: 2432

PTO/SB/08a (07-09)

Approved for use through 07/31/2012. OMB 0651-0031

U.S. Patent and Trademark Office; U.S. DEPARTMENT OF COMMERCE

Under the Paperwork Reduction Act of 1995, no persons are required to respond to a collection of information unless it contains a valid OMB control number.

Substitute for form 1449/PTO		Complete if Known	
INFORMATION DISCLOSURE STATEMENT BY APPLICANT <i>(Use as many sheets as necessary)</i>		Application Number	11/894,388
		Filing Date	Aug 21, 2007
		First Named Inventor	Scott A Moskowitz
		Art Unit	2432
		Examiner Name	NA
		Attorney Docket Number	80391.0003 WNTZ
Sheet	4	of	4

U. S. PATENT DOCUMENTS					
Examiner Initials*	Cite No. ¹	Document Number	Publication Date MM-DD-YYYY	Name of Patentee or Applicant of Cited Document	Pages, Columns, Lines, Where Relevant Passages or Relevant Figures Appear
		Number-Kind Code ² (if known)			
		US-5,748,783	05/05/1998	Rhoads	
		US-5,850,481	12/15/1998	Rhoads	
		US-5,860,099	01/12/1999	Milios et al.	
		US-6,363,483	03/26/2002	Keshav	
		US-7,162,642	01/09/2007	Schumann et al.	
		US-6,834,308	12/21/2004	Ikezoey et al.	
		US-6,968,337	11/22/2005	Wold	6,968,337
		US-7,363,278	04/22/2008	Schmelzer et al.	
		US-2002/0073043	06/13/2002	Herman et al.	
		US-2004/0125983	07/01/2004	Reed et al.	
		US-2002/0161741	10/31/2002	Wang et al.	
		US-7,289,643	10/30/2007	Brunk et al.	
		US-7,286,451	10/23/2007	Wirtz et al.	
		US-			
		US-			
		US-			
		US-			
		US-			
		US-			

Change(s) applied
to document,
/D.D./
6/27/2015

FOREIGN PATENT DOCUMENTS						
Examiner Initials*	Cite No. ¹	Foreign Patent Document	Publication Date MM-DD-YYYY	Name of Patentee or Applicant of Cited Document	Pages, Columns, Lines, Where Relevant Passages Or Relevant Figures Appear	T ⁶
		Country Code ³ -Number ⁴ -Kind Code ⁵ (if known)				

Examiner Signature	/Izunna Okeke/	Date Considered	03/22/2010
--------------------	----------------	-----------------	------------

*EXAMINER: Initial if reference considered, whether or not citation is in conformance with MPEP 609. Draw line through citation if not in conformance and not considered. Include copy of this form with next communication to applicant. ¹ Applicant's unique citation designation number (optional). ² See Kinds Codes of USPTO Patent Documents at www.uspto.gov or MPEP 901.04. ³ Enter Office that issued the document, by the two-letter code (WIPO Standard ST.3). ⁴ For Japanese patent documents, the indication of the year of the reign of the Emperor must precede the serial number of the patent document. ⁵ Kind of document by the appropriate symbols as indicated on the document under WIPO Standard ST.16 if possible. ⁶ Applicant is to place a check mark here if English language Translation is attached.

This collection of information is required by 37 CFR 1.97 and 1.98. The information is required to obtain or retain a benefit by the public which is to file (and by the USPTO to process) an application. Confidentiality is governed by 35 U.S.C. 122 and 37 CFR 1.14. This collection is estimated to take 2 hours to complete, including gathering, preparing, and submitting the completed application form to the USPTO. Time will vary depending upon the individual case. Any comments on the amount of time you require to complete this form and/or suggestions for reducing this burden, should be sent to the Chief Information Officer, U.S. Patent and Trademark Office, P.O. Box 1450, Alexandria, VA 22313-1450. DO NOT SEND FEES OR COMPLETED FORMS TO THIS ADDRESS. SEND TO: Commissioner for Patents, P.O. Box 1450, Alexandria, VA 22313-1450.

If you need assistance in completing the form, call 1-800-PTO-9199 (1-800-786-9199) and select option 2.

ALL REFERENCES CONSIDERED EXCEPT WHERE LINED THROUGH. /I.O./

Receipt date: 10/19/2007

11895388 - GAU: 2432

PTO/SB/08A (09-06)

Approved for use through 03/31/2007. OMB 0651-0031

U.S. Patent and Trademark Office; U.S. DEPARTMENT OF COMMERCE

Under the Paperwork Reduction Act of 1995, no persons are required to respond to a collection of information unless it contains a valid OMB control number.

Substitute for form 1449/PTO		Complete if Known	
INFORMATION DISCLOSURE STATEMENT BY APPLICANT <i>(Use as many sheets as necessary)</i>		Application Number	11/895,388
		Filing Date	August 24, 2007
		First Named Inventor	Scott A. MOSKOWITZ
		Art Unit	2132
		Examiner Name	NA
		Attorney Docket Number	80391.0003CONT2
Sheet	9	of	12

U. S. PATENT DOCUMENTS

Examiner Initials*	Cite No. ¹	Document Number	Publication Date MM-DD-YYYY	Name of Patentee or Applicant of Cited Document	Pages, Columns, Lines, Where Relevant Passages or Relevant Figures Appear
		Number-Kind Code ² (if known)			
		US-5,754,697	05/19/1998	Fu et al.	
		US-5,479,210	12/26/1995	Cawley et al.	
		US-3,947,825	03/30/1976	Cassada	
		US-5,903,721	05/11/1999	Sixtus	
		US-5,790,677	08/04/1998	Fox et al.	
		US-5,243,515	09/07/1993	Clearwater Lee	
		US-4,339,134	07/13/1982	Macheel	
		US-4,827,508	05/02/1989	Shear	
		US-4,896,275	01/23/1990	Jackson	
		US-4,977,594	12/11/1990	Shear	
		US-5,050,213	09/17/1991	Shear	
		US-5,369,707	11/29/1994	Follendore, III	
		US-5,406,627	04/11/1995	Thompson et al.	
		US-5,410,598	04/25/1995	Shear	
		US-5,469,536	11/21/1995	Blank	
		US-5,497,419	03/05/1996	Hill	
		US-5,513,261	04/30/1996	Maher	
		US-5,530,739	06/25/1996	Okada	
		US-5,598,470	01/28/1997	Cooper et al.	

Change(s) applied to document, /D.D./ 6/27/2015

FOREIGN PATENT DOCUMENTS

Examiner Initials*	Cite No. ¹	Foreign Patent Document	Publication Date MM-DD-YYYY	Name of Patentee or Applicant of Cited Document	Pages, Columns, Lines, Where Relevant Passages Or Relevant Figures Appear	T ⁶
		Country Code ³ Number ⁴ Kind Code ⁵ (if known)				

Examiner Signature	/Izunna Okeke/	Date Considered	03/31/2010
--------------------	----------------	-----------------	------------

*EXAMINER: Initial if reference considered, whether or not citation is in conformance with MPEP 609. Draw line through citation if not in conformance and not considered. Include copy of this form with next communication to applicant. ¹ Applicant's unique citation designation number (optional). ² See Kinds Codes of USPTO Patent Documents at www.uspto.gov or MPEP 901.04. ³ Enter Office that issued the document, by the two-letter code (WIPO Standard ST.3). ⁴ For Japanese patent documents, the indication of the year of the reign of the Emperor must precede the serial number of the patent document. ⁵ Kind of document by the appropriate symbols as indicated on the document under WIPO Standard ST.16 if possible. ⁶ Applicant is to place a check mark here if English language Translation is attached.

This collection of information is required by 37 CFR 1.97 and 1.98. The information is required to obtain or retain a benefit by the public which is to file (and by the USPTO to process) an application. Confidentiality is governed by 35 U.S.C. 122 and 37 CFR 1.14. This collection is estimated to take 2 hours to complete, including gathering, preparing, and submitting the completed application form to the USPTO. Time will vary depending upon the individual case. Any comments on the amount of time you require to complete this form and/or suggestions for reducing this burden, should be sent to the Chief Information Officer, U.S. Patent and Trademark Office, P.O. Box 1450, Alexandria, VA 22313-1450. DO NOT SEND FEES OR COMPLETED FORMS TO THIS ADDRESS. SEND TO: Commissioner for Patents, P.O. Box 1450, Alexandria, VA 22313-1450.

If you need assistance in completing the form, call 1-800-PTO-9199 (1-800-786-9199) and select option 2.

ALL REFERENCES CONSIDERED EXCEPT WHERE LINED THROUGH. /I.O./

Receipt date: 10/19/2007

11895388 - GAU: 2432

PTO/SB/08A (09-06)

Approved for use through 03/31/2007. OMB 0651-0031
U.S. Patent and Trademark Office; U.S. DEPARTMENT OF COMMERCE

Under the Paperwork Reduction Act of 1995, no persons are required to respond to a collection of information unless it contains a valid OMB control number.

Substitute for form 1449/PTO		Complete if Known	
INFORMATION DISCLOSURE STATEMENT BY APPLICANT <i>(Use as many sheets as necessary)</i>		Application Number	11/895,388
		Filing Date	August 24, 2007
		First Named Inventor	Scott A. MOSKOWITZ
		Art Unit	2132
		Examiner Name	NA
		Attorney Docket Number	80391.0003CONT2
Sheet	4	of	12

U. S. PATENT DOCUMENTS					
Examiner Initials*	Cite No. ¹	Document Number	Publication Date MM-DD-YYYY	Name of Patentee or Applicant of Cited Document	Pages, Columns, Lines, Where Relevant Passages or Relevant Figures Appear
		Number-Kind Code ² (if known)			
		US-5,640,569	06/17/1997	Miller, et al.	
		US-5,659,726	08/19/1997	Sandford, II, et al.	
		US-5,664,018	09/02/1997	Leighton	
		US-5,687,236	11/11/1997	Moskowitz, et al.	
		US-5,734,752	03/31/1998	Knox	
		US-5,745,569	04/28/1998	Moskowitz, et al.	
		US-5,506,795	04/09/1996	Yamakawa	
		US-5,680,462	10/21/1997	Miller, et al.	
		US-5,696,828	12/09/1997	Koopman, Jr.	
		US-5,740,244	04/14/1998	ndeck, et al.	
		US-5,751,811	05/12/1998	Koopman, Jr.	Magnotti, et al.
		US-5,757,923	05/26/1998	Koopman, Jr.	
		US-5,889,868	03/30/1999	Moskowitz, et al.	
		US-6,208,745	03/27/2001	Florenio, et al.	
		US-6,285,775	09/04/2001	Wu, et al.	
		US-6,385,329	05/07/2002	Sharma, et al.	
		US-6,530,021	03/04/2003	Epstein, et al.	
		US-6,425,081	07/23/2002	Iwamura	
		US-			

Change(s) applied to document, /D.D./ 6/27/2015

FOREIGN PATENT DOCUMENTS						
Examiner Initials*	Cite No. ¹	Foreign Patent Document	Publication Date MM-DD-YYYY	Name of Patentee or Applicant of Cited Document	Pages, Columns, Lines, Where Relevant Passages Or Relevant Figures Appear	T ⁶
		Country Code ³ Number ⁴ Kind Code ⁵ (if known)				

Examiner Signature	/Izunna Okeke/	Date Considered	03/31/2010
--------------------	----------------	-----------------	------------

*EXAMINER: Initial if reference considered, whether or not citation is in conformance with MPEP 609. Draw line through citation if not in conformance and not considered. Include copy of this form with next communication to applicant. ¹ Applicant's unique citation designation number (optional). ² See Kinds Codes of USPTO Patent Documents at www.uspto.gov or MPEP 901.04. ³ Enter Office that issued the document, by the two-letter code (WIPO Standard ST.3). ⁴ For Japanese patent documents, the indication of the year of the reign of the Emperor must precede the serial number of the patent document. ⁵ Kind of document by the appropriate symbols as indicated on the document under WIPO Standard ST.16 if possible. ⁶ Applicant is to place a check mark here if English language Translation is attached.

This collection of information is required by 37 CFR 1.97 and 1.98. The information is required to obtain or retain a benefit by the public which is to file (and by the USPTO to process) an application. Confidentiality is governed by 35 U.S.C. 122 and 37 CFR 1.14. This collection is estimated to take 2 hours to complete, including gathering, preparing, and submitting the completed application form to the USPTO. Time will vary depending upon the individual case. Any comments on the amount of time you require to complete this form and/or suggestions for reducing this burden, should be sent to the Chief Information Officer, U.S. Patent and Trademark Office, P.O. Box 1450, Alexandria, VA 22313-1450. DO NOT SEND FEES OR COMPLETED FORMS TO THIS ADDRESS. SEND TO: Commissioner for Patents, P.O. Box 1450, Alexandria, VA 22313-1450.

If you need assistance in completing the form, call 1-800-PTO-9199 (1-800-786-9199) and select option 2.

ALL REFERENCES CONSIDERED EXCEPT WHERE LINED THROUGH. /I.O./

Receipt date: 10/19/2007

11895388 - GAU: 2432

App. No. 11895388

Information Disclosure Statement / C.F.R. § 1.78 dated October 17, 2007

Change(s) applied
to document, _____

/D.D./

6/27/2015

- _____ U.S. Patent No. 7,123,718, issued October 17, 2006, entitled, "Utilizing Data Reduction in Steganographic and Cryptographic Systems"; Moskowitz, et al.
- _____ U.S. Patent No. 7,127,615, issued October 24, 2006, "Improved Security Based on Subliminal and Supraliminal Channels for Data Objects"; Moskowitz
- _____ U.S. Patent No. 7,152,162, issued December 19, 2006, entitled "Z-Transform Implementation of Digital Watermarks"; Moskowitz, et al.
- _____ U.S. Patent No. 7,159,116, issued January 2, 2007, entitled "Systems, Methods and Devices for Trusted Transactions"; Moskowitz
- _____ U.S. Patent No. 7,177,429, issued February 13, 2007, entitled "System and Methods for Permitting Open Access to Data Objects and for Securing Data within the Data Objects" Moskowitz, et al.

EXAMINER: Please initial if reference is considered, whether or not the citation is in conformance with MPEP § 609. Draw line through citation if not in conformance and not considered. Please include copy of this form with next communication to the applicant.

Receipt date: 10/19/2007

11895388 - GAU: 2432

App. No. 11/895,388

Information Disclosure Statement / C.F.R. § 1.78 dated October 17, 2007

Change(s) applied
to document,

/D.D./

6/27/2015

- _____ U.S. Patent No. 5,822,432, issued October 13, 1998, entitled "Method for Human Assisted Random Key Generation and Application for Digital Watermark System"; Moskowitz, et al.
- _____ U.S. Patent No. 5,889,868, issued ~~July 2, 1996~~, entitled "Optimization Methods for the Insertion, Protection, and Detection of Digital Watermarks in Digitized Data"; Moskowitz, et al. March 30, 1999
- _____ U.S. Patent No. 5,905,800, issued May 18, 1999, entitled "Method & System for Digital Watermarking"; Moskowitz, et al.
- _____ U.S. Patent No. 6,078,664, issued June 20, 2000, entitled "Z-Transform Implementation of Digital Watermarks"; Moskowitz, et al.
- _____ U.S. Patent No. 6,205,249, issued March 20, 2001, entitled "Multiple Transform Utilization and Application for Secure Digital Watermarking"; Moskowitz
- _____ U.S. Patent No. 6,522,767, issued February 18, 2003, entitled "Optimization Methods for the Insertion, Protection, and Detection of Digital Watermarks in Digitized Data"; Moskowitz, et al.
- _____ U.S. Patent No. 6,598,162, issued July 22, 2003, entitled "Method for Combining Transfer Function with Predetermined Key Creation"; Moskowitz
- _____ U.S. Patent No. 6,853,726, issued February 8, 2005, entitled "Z-Transform Implementation of Digital Watermarks"; Moskowitz, et al.
- _____ U.S. Patent No. 7,007,166, issued February 28, 2006, entitled "Method & System for Digital Watermarking"; Moskowitz, et al.
- _____ U.S. Patent No. 7,035,049, issued April 25, 2006, entitled "Multiple Transform Utilization and Application for Secure Digital Watermarking"; Yamamoto, et al.
- _____ U.S. Patent No. 7,095,874, issued August 22, 2006, entitled "Optimization Methods for the Insertion, Protection, and Detection of Digital Watermarks in Digitized Data"; Moskowitz, et al.
- _____ U.S. Patent No. 7,107,451, issued September 12, 2006, entitled "Optimization Methods for the Insertion, Protection, and Detection of Digital Watermarks in Digital Data"; Moskowitz

EXAMINER: Please initial if reference is considered, whether or not the citation is in conformance with MPEP § 609. Draw line through citation if not in conformance and not considered. Please include copy of this form with next communication to the applicant.

Receipt date: 10/19/2007

11895388 - GAU: 2432

App. No. 11/895,388

Information Disclosure Statement / C.F.R. § 1.78 dated October 17, 2007

Change(s) applied
to document,

/D.D./

6/27/2015

- _____ Channels For Data Objects" -- Publication No. 20020056041 -- May 9, 2002 (issued as U.S. Patent No. 7,127,615); Moskowitz October 24, 2006
- _____ U.S. Patent Application No. 11/518,806, filed September 11, 2006, entitled "Improved Security Based on Subliminal and Supraliminal Channels For Data Objects";
- _____ U.S. Patent Application No. 11/026,234, filed December 30, 2004, entitled "Z-Transform Implementation of Digital Watermarks" -- Publication No. 20050135615 -- June 23, 2005 (issued as U.S. Patent No. 7,152,162); Moskowitz, et al. December 19, 2006
- _____ U.S. Patent Application No. 11/592,079, filed November 2, 2006, entitled "Linear Predictive Coding Implementation of Digital Watermarks" -- Publication No. 20070079131 -- April 5, 2007; Moskowitz; Scott A.; et al.
- _____ U.S. Patent Application No. 09/731,039, filed December 7, 2000, entitled "System and Methods for Permitting Open Access to Data Objects and for Securing Data within the Data Objects" -- Publication No. 20020071556 -- June 13, 2002 (issued as U.S. Patent No. 7,177,429); Moskowitz, et al. February 13, 2007
- _____ U.S. Patent Application No. 11/647,861, filed December 29, 2006, entitled "System and Methods for Permitting Open Access to Data Objects and for Securing Data within the Data Objects" -- Publication No. 20070110240 -- April 5, 2007; Moskowitz; Scott A.; et al. May 17, 2007
- _____ U.S. Patent No. 5,428,606, issued June 27, 1995, entitled "Digital Commodities Exchange"; Moskowitz
- _____ U.S. Patent No. 5,539,735, issued July 23, 1996, entitled "Digital Information Commodities Exchange"; Moskowitz
- _____ U.S. Patent No. 5,613,004, issued March 18, 1997, entitled "Steganographic Method and Device"; Cooperman, et al.
- _____ U.S. Patent No. 5,687,236, issued November 11, 1997, entitled "Steganographic Method and Device"; Moskowitz, et al.
- _____ U.S. Patent No. 5,745,569, issued April 28, 1998, entitled "Method for Stega-Protection of Computer Code"; Moskowitz, et al.

EXAMINER: Please initial if reference is considered, whether or not the citation is in conformance with MPEP § 609. Draw line through citation if not in conformance and not considered. Please include copy of this form with next communication to the applicant.

Receipt date: 10/19/2007

11895388 - GAU: 2432

App. No. 11/895,388

Information Disclosure Statement / C.F.R. § 1.78 dated October 17, 2007

Change(s) applied
to document,

/D.D./
6/27/2015

- _____ U.S. Patent Application No. 11/482,654, filed July 7, 2006, entitled "Optimization Methods for the Insertion, Protection, and Detection of Digital Watermarks in Digitized Data" -- Publication No. 20060285722 -- December 21, 2006; Moskowitz; Scott A.; et al.
- _____ U.S. Patent Application No. 09/594,719, filed June 16, 2000, entitled "Utilizing Data Reduction in Steganographic and Cryptographic Systems" (issued as U.S. Patent 7,123,718); Moskowitz, et al. October 17, 2006
- _____ U.S. Patent Application No. 11/519,467, filed September 12, 2006, entitled "Utilizing Data Reduction in Steganographic and Cryptographic Systems" -- Publication No. 20070064940 -- March 22, 2007; Moskowitz; Scott A.; et al.
- _____ U.S. Patent Application No 09/731,040, filed December 7, 2000, entitled "Systems, Methods And Devices For Trusted Transactions" -- Publication No. 20020010684 -- January 24, 2002 (issued as U.S. Patent 7,159,116); Moskowitz January 2, 2007
- _____ U.S. Patent Application No 11/512,701, filed August 29, 2006, entitled "Systems, Methods And Devices For Trusted Transactions" -- Publication No. 20070028113 -- February 1, 2007; Moskowitz; Scott A.
- _____ U.S. Patent Application No. 10/049,101, filed February 8, 2002, entitled "A Secure Personal Content Server" (which claims priority to International Application No. PCT/US00/21189, filed August 4, 2000, which claims priority to U.S. Patent Application No. 60/147,134, filed August 4, 1999, and to U.S. Patent Application No. 60/213,489, filed June 23, 2000);
- _____ U.S. Patent Application No. 09/657,181, filed September 7, 2000, entitled "Method And Device For Monitoring And Analyzing Signals";
- _____ U.S. Patent Application No. 10/805,484, filed March 22, 2004, entitled "Method And Device For Monitoring And Analyzing Signals"(which claims priority to U.S. Patent Application No. 09/671,739, filed September 29, 2000, which is a CIP of U.S. Patent Application No. 09/657,181) -- Publication No. 20040243540 -- December 2, 2004; Moskowitz, Scott A.; et al.
- _____ U.S. Patent Application No. 09/956,262, filed September 20, 2001, entitled "Improved Security Based on Subliminal and Supraliminal

EXAMINER: Please initial if reference is considered, whether or not the citation is in conformance with MPEP § 609. Draw line through citation if not in conformance and not considered. Please include copy of this form with next communication to the applicant.

Change(s) applied
to document,

/D.D./
6/27/2015

- _____ "Digital Watermarks in Digital Data" – Publication No. 20010010078 -
October 11, 2001 (issued as U.S. Patent No. 7,107,451); Moskowitz September 12, 2006
- _____ U.S. Patent Application No. 11/497,822, filed August 2, 2006, entitled
"Optimization Methods for the Insertion, Protection, and Detection of
Digital Watermarks in Digital Data" – Publication No. 20070011458 –
January 11, 2007; Moskowitz; Scott A.
- _____ U.S. Patent Application No. 11/599,964, filed November 15, 2006, entitled
"Optimization Methods for the Insertion, Protection, and Detection of
Digital Watermarks in Digital Data";
- _____ U.S. Patent Application No. 11/599,838, filed November 15, 2006, entitled
"Optimization Methods for the Insertion, Protection, and Detection of
Digital Watermarks in Digital Data" – Publication No. 20070226506 –
September 27, 2007; Moskowitz; Scott A.
- _____ U.S. Patent Application No. 11/897,790, filed August 31, 2007, entitled
"Optimization Methods for the Insertion, Protection, and Detection of
Digital Watermarks in Digital Data";
- _____ U.S. Patent Application No. 11/897,791, filed August 31, 2007, entitled
"Optimization Methods for the Insertion, Protection, and Detection of
Digital Watermarks in Digital Data";
- _____ U.S. Patent Application No. 11/899,661, filed September 7, 2007, entitled
"Optimization Methods for the Insertion, Protection, and Detection of
Digital Watermarks in Digital Data";
- _____ U.S. Patent Application No. 11/899,662, filed September 7, 2007, entitled
"Optimization Methods for the Insertion, Protection, and Detection of
Digital Watermarks in Digital Data";
- _____ U.S. Patent Application No. 10/369,344, filed February 18, 2003, entitled
"Optimization Methods for the Insertion, Protection, and Detection of
Digital Watermarks in Digitized Data" – Publication No. 20030219143 –
November 27, 2003 (issued as U.S. Patent No. 7,095,874);
Moskowitz, et al. August 22, 2006

EXAMINER: Please initial if reference is considered, whether or not the citation is in conformance with MPEP § 609. Draw line through citation if not in conformance and not considered. Please include copy of this form with next communication to the applicant.

- _____ U.S. Patent Application 10/602,777, filed June 25, 2003, entitled "Method for Combining Transfer Function with Predetermined Key Creation" – Publication No. 20040086119 – May 6, 2004; Moskowitz, Scott A.
- _____ U.S. Patent Application 11/895,388, filed August 24, 2007, entitled "Data Protection Method and Device";
- _____ U.S. Patent Application No. 09/053,628, filed April 2, 1998, entitled "Multiple Transform Utilization and Application for Secure Digital Watermarking" (issued as U.S. Patent No. 6,205,249);
- _____ U.S. Patent Application No. 09/644,098, filed August 23, 2000, entitled "Multiple Transform Utilization and Application for Secure Digital Watermarking" (issued as U.S. Patent No. 7,035,409);
- _____ U.S. Patent Application No. 09/767,733, filed January 24, 2001, entitled "Multiple Transform Utilization and Application for Secure Digital Watermarking" – Publication No. 20010010078 - July 26, 2001; Moskowitz, Scott A.
- _____ U.S. Patent Application No. 11/358,874, filed February 21, 2006, entitled "Multiple Transform Utilization and Application for Secure Digital Watermarking" – Publication No. 20060140403 – June 29, 2006; Moskowitz, Scott A.
- _____ U.S. Patent Application No. 10/417,231, filed April 17, 2003, entitled "Methods, Systems And Devices For Packet Watermarking And Efficient Provisioning Of Bandwidth" – Publication No. 20030200439 – October 23, 2003; Moskowitz, Scott A.
- _____ U.S. Patent Application No. 11/900,065, filed September 10, 2007, entitled "Methods, Systems And Devices For Packet Watermarking And Efficient Provisioning Of Bandwidth";
- _____ U.S. Patent Application No. 11/900,066, filed September 10, 2007, entitled "Methods, Systems And Devices For Packet Watermarking And Efficient Provisioning Of Bandwidth";
- _____ U.S. Patent Application No. 09/789,711, filed February 22, 2001, entitled "Optimization Methods for the Insertion, Protection, and Detection of

Change(s) applied to document, /D.D./ 6/27/2015

EXAMINER: Please initial if reference is considered, whether or not the citation is in conformance with MPEP § 609. Draw line through citation if not in conformance and not considered. Please include copy of this form with next communication to the applicant.

U.S. PATENT DOCUMENTS

EXAMINER'S

INITIALS:

_____ U.S. Patent Application No. 08/999,766, filed July 23, 1997, entitled "Steganographic Method and Device";

_____ U.S. Patent Application No. 11/894,443, filed August 21, 2007, entitled "Steganographic Method and Device";

_____ U.S. Patent Application No. 11/894,476, filed August 21, 2007, entitled "Steganographic Method and Device";

_____ U.S. Patent Application No. 11/050,779, filed February 7, 2005, entitled "Steganographic Method and Device" – Publication No. 20050177727 – August 11, 2005; Moskowitz, Scott A.; et al.

Change(s) applied
to document,
/D.D./
6/27/2015

_____ U.S. Patent Application No. 08/674,726, filed July 2, 1996, entitled "Exchange Mechanisms for Digital Information Packages with Bandwidth Securitization, Multichannel Digital Watermarks, and Key Management";

_____ U.S. Patent Application No. 09/545,589, filed April 7, 2000, entitled "Method and System for Digital Watermarking" (issued as U.S. Patent No. 7,007,166); Moskowitz, et al. February 28, 2006

_____ U.S. Patent Application No. 11/244,213, filed October 5, 2005, entitled "Method and System for Digital Watermarking" – Publication No. 20060101269 – May 11, 2006; Moskowitz, Scott A.; et al.

_____ U.S. Patent Application No. 11/649,026, filed January 3, 2007, entitled "Method and System for Digital Watermarking" – Publication No. 20070113094 – May 17, 2007; Moskowitz, Scott A.; et al.

_____ U.S. Patent Application No. 09/046,627, filed March 24, 1998, entitled "Method for Combining Transfer Function with Predetermined Key Creation" (issued as U.S. Patent No. 6,598,162); Moskowitz July 22, 2003

EXAMINER: Please initial if reference is considered, whether or not the citation is in conformance with MPEP § 609. Draw line through citation if not in conformance and not considered. Please include copy of this form with next communication to the applicant.



UNITED STATES PATENT AND TRADEMARK OFFICE

UNITED STATES DEPARTMENT OF COMMERCE
United States Patent and Trademark Office
Address: COMMISSIONER FOR PATENTS
P.O. Box 1450
Alexandria, Virginia 22313-1450
www.uspto.gov

APPLICATION NO.	ISSUE DATE	PATENT NO.	ATTORNEY DOCKET NO.	CONFIRMATION NO.
11/895,388	08/11/2015	9104842	SCOT0014-4	2103

31518 7590 07/22/2015
NEIFELD IP LAW, PC
4813-B EISENHOWER AVENUE
ALEXANDRIA, VA 22304

ISSUE NOTIFICATION

The projected patent number and issue date are specified above.

Determination of Patent Term Adjustment under 35 U.S.C. 154 (b)
(application filed on or after May 29, 2000)

The Patent Term Adjustment is 1965 day(s). Any patent to issue from the above-identified application will include an indication of the adjustment on the front page.

If a Continued Prosecution Application (CPA) was filed in the above-identified application, the filing date that determines Patent Term Adjustment is the filing date of the most recent CPA.

Applicant will be able to obtain more detailed information by accessing the Patent Application Information Retrieval (PAIR) WEB site (<http://pair.uspto.gov>).

Any questions regarding the Patent Term Extension or Adjustment determination should be directed to the Office of Patent Legal Administration at (571)-272-7702. Questions relating to issue and publication fee payments should be directed to the Application Assistance Unit (AAU) of the Office of Data Management (ODM) at (571)-272-4200.

APPLICANT(s) (Please see PAIR WEB site <http://pair.uspto.gov> for additional applicants):

Scott A. Moskowitz, Sunny Isles Beach, FL;

The United States represents the largest, most dynamic marketplace in the world and is an unparalleled location for business investment, innovation, and commercialization of new technologies. The USA offers tremendous resources and advantages for those who invest and manufacture goods here. Through SelectUSA, our nation works to encourage and facilitate business investment. To learn more about why the USA is the best country in the world to develop technology, manufacture products, and grow your business, visit SelectUSA.gov.

AO 120 (Rev. 08/10)

TO: Mail Stop 8 Director of the U.S. Patent and Trademark Office P.O. Box 1450 Alexandria, VA 22313-1450	REPORT ON THE FILING OR DETERMINATION OF AN ACTION REGARDING A PATENT OR TRADEMARK
---	---

In Compliance with 35 U.S.C. § 290 and/or 15 U.S.C. § 1116 you are hereby advised that a court action has been filed in the U.S. District Court Eastern District of Texas on the following
 Trademarks or Patents. (the patent action involves 35 U.S.C. § 292.):

DOCKET NO. 6:17-cv-0016	DATE FILED 1/6/2017	U.S. DISTRICT COURT Eastern District of Texas
PLAINTIFF Blue Spike, PLLC		DEFENDANT JUNIPER NETWORKS, INC.
PATENT OR TRADEMARK NO.	DATE OF PATENT OR TRADEMARK	HOLDER OF PATENT OR TRADEMARK
1 9021602	Apr 28, 2015	Blue Spike LLC
2 9104842	Aug 11, 2015	Blue Spike LLC
3		
4		
5		

In the above—entitled case, the following patent(s)/ trademark(s) have been included:

DATE INCLUDED	INCLUDED BY <input type="checkbox"/> Amendment <input type="checkbox"/> Answer <input type="checkbox"/> Cross Bill <input type="checkbox"/> Other Pleading	
PATENT OR TRADEMARK NO.	DATE OF PATENT OR TRADEMARK	HOLDER OF PATENT OR TRADEMARK
1		
2		
3		
4		
5		

In the above—entitled case, the following decision has been rendered or judgement issued:

DECISION/JUDGEMENT

CLERK	(BY) DEPUTY CLERK	DATE
-------	-------------------	------

Copy 1—Upon initiation of action, mail this copy to Director Copy 3—Upon termination of action, mail this copy to Director
 Copy 2—Upon filing document adding patent(s), mail this copy to Director Copy 4—Case file copy

Print

Save As...

Reset