

20427 U.S. PTO
111804

CHOATE, HALL & STEWART
A PARTNERSHIP INCLUDING PROFESSIONAL CORPORATIONS
EXCHANGE PLACE
53 STATE STREET
BOSTON, MASSACHUSETTS 02109-2891
TELEPHONE (617) 248-5000
FACSIMILE (617) 248-4000

19587 U.S. PTO
10/991774
111804

Mail Stop Patent Application
Commissioner for Patents
P.O. Box 1450
Alexandria, VA 22313-1450

Express Mail No.: EV196632874US
Attorney Docket No.: 0492611-0598
Date Filed: November 18, 2004

CERTIFICATE OF MAILING

"Express Mail" mailing label number EV 196632874 US

Date of Deposit: November 18, 2004

I hereby certify that this correspondence is being deposited with the United States Postal Service as "*Express Mail Post Office to Address*" service under 37 CFR 1.10 on the date indicated above and is addressed to: Commissioner for Patents, P.O. Box 1450, Alexandria, VA 22313-1450

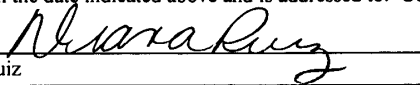
Diana Ruiz

UTILITY PATENT APPLICATION TRANSMITTAL

(for new nonprovisional applications under 37 C.F.R. § 1.53(b))

Dear Sir:

Please find enclosed a patent application and papers as follows for:

Inventor(s):

<u>Given Name (first and middle)</u>	<u>Family Name or Surname</u>	<u>Residence (City and State or Foreign Country)</u>
DANIEL R.	COHN	CHESTNUT HILL, MASSACHUSETTS
LESLIE	BROMBERG	SHARON, MASSACHUSETTS
JOHN B.	HEYWOOD	NEWTON, MASSACHUSETTS

Title of the Invention: **FUEL MANAGEMENT SYSTEM FOR VARIABLE ETHANOL
OCTANE ENHANCEMENT OF GASOLINE ENGINES**

A) APPLICATION ELEMENTS:

- 1) **Fee Transmittal Form** (original and duplicate submitted for fee processing)
- 2) **Applicant Claims Small Entity Status** (see 37 C.F.R. § 1.27)
 - a) Statement Verifying Small Entity Status (optional)

- 3) **Specification** TOTAL PAGES: 14
 Cover Page
 Descriptive Title of the Invention
 Background of the Invention
 Summary of the Invention
 Brief Description of the Drawing (if filed)
 Description of the Preferred Embodiment
 Claim(s) (3 pgs.)
 Abstract of the Invention (1 pg.)
- 4) **Drawing(s)** (35 U.S.C. § 113) TOTAL SHEETS: 3
a) Formal Drawings (if checked)
- 5) **Oath or Declaration** TOTAL PAGES: _____
a) Newly Executed (original or copy)
b) Copy from a prior application (37 C.F.R. § 1.63(d))-for continuation/divisional application
i) Deletion of inventor(s): Signed Statement deleting inventor(s) named in the prior application, see 37 C.F.R. §§ 1.63(d)(2) and 1.33(b).
c) Unexecuted
- 6) **Application Data Sheet**. See 37 C.F.R. § 1.76.
- 7) **CD-ROM or CD-R in duplicate, large table or Computer Program (Appendix)**
- 8) **Nucleotide and/or Amino Acid Sequence Submission** (if applicable, all are necessary)
a) Computer Readable Form (CRF)
b) Specification Sequence Listing on:
i) CD-ROM or CD-R (2 copies); or
ii) Paper
c) Statements verifying identity of above copies

B) ACCOMPANYING APPLICATION PARTS:

- 9) **Assignment Papers** (cover sheet & document(s))
- 10) **37 C.F.R. § 3.73(b) Statement** (when there is an assignee)
- 11) **Power of Attorney**
- 12) **English Translation Document** (if applicable)
- 13) **Information Disclosure Statement (IDS)/PTO-1449**
- 14) **Copies of IDS Citations**
- 15) **Preliminary Amendment**
- 16) **Return Receipt Postcard (MPEP 503)** (specifically itemized)
- 17) **Certified Copy of Priority Document(s)** (if foreign priority is claimed)
- 18) **Nonpublication Request under 35 U.S.C. § 122(b)(2)(B)(i)**
- 19) **OTHER:** (if applicable, specified below)

C) FOR CONTINUING APPLICATIONS: (the appropriate box is checked, and certain information is provided below and in a preliminary amendment)

- continuation divisional continuation-in-part (CIP)

of prior application no.: _____
filed: _____
examiner: _____
group/art unit: _____

for continuation or divisional applications only: The entire disclosure of the prior application, from which an oath or declaration is supplied as detailed above, is considered a part of the disclosure of the accompanying continuation or divisional application and is hereby incorporated by reference.

D.) PRIORITY CLAIM(S):

This application claims the benefit under 35 U.S.C. § 120 of any United States application(s) or PCT international application(s) designating the United States of America listed below:

<u>Application Serial No.</u>	<u>Filing date</u>	<u>Status (patented, pending, abandoned)</u>
-------------------------------	--------------------	--

This application claims the benefit under 35 U.S.C. § 119(e) of any United States provisional application(s) listed below:

<u>Application Serial No.</u>	<u>Filing date</u>	<u>Status (pending, expired, abandoned)</u>
-------------------------------	--------------------	---

E) METHOD OF PAYMENT OF FILING FEES FOR THIS APPLICATION:

- Applicant claims small entity status 37 C.F.R. § 1.27.
- A check for \$422.00 is enclosed to cover the filing fees.
- The commissioner is hereby authorized to charge filing fees or to credit any overpayment to deposit account number 03-1721.

Basic Filing Fee (Small Entity)	\$395.00
Additional Fees:	
Total Number of Claims in excess of 20: (23 – 20) x \$9	\$27.00
Number of Independent Claims in excess of 3:(2 – 3) x \$43	\$0.00
Multiple Dependent Claims \$150:	<u>\$0.00</u>
Total Filing Fee:	\$422.00

F) CORRESPONDENCE ADDRESS:

- Customer Number: 24280

Respectfully Submitted,



Sam Pasternack
Registration No. 29,576

CHOATE, HALL & STEWART
53 State Street
Exchange Place
Boston, MA 02109
Phone: (617) 248-5000
Fax: (617) 248-4000

Express Mail No.: EV196632874US
Attorney Docket: 0492611-0598
Date Filed: November 18, 2004

JOINT

**APPLICATION
FOR
UNITED STATES LETTERS PATENT**

TO THE ASSISTANT COMMISSIONER FOR PATENTS:

BE IT KNOWN, that we,

Daniel R. Cohn, Chestnut Hill, Massachusetts

Leslie Bromberg, Sharon, Massachusetts

John B. Heywood, Newton, Massachusetts

have invented certain new and useful improvements in **Fuel Management System for Variable Ethanol Octane Enhancement of Gasoline Engines** of which the following is a specification:

Attorney Docket No.: 0492611-0598
Express Mail No. EV196632874US
Date of Filing: November 18, 2004
Customer Number: 24280

Fuel Management System for Variable Ethanol Octane Enhancement of Gasoline Engines

Background of the Invention

This invention relates to spark ignition gasoline engines utilizing an antiknock agent
5 which is a liquid fuel with a higher octane number than gasoline such as ethanol to improve
engine efficiency.

It is known that the efficiency of spark ignition (SI) gasoline engines can be increased by
high compression ratio operation and particularly by engine downsizing. The engine downsizing
is made possible by the use of substantial pressure boosting from either turbocharging or
10 supercharging. Such pressure boosting makes it possible to obtain the same performance in a
significantly smaller engine. See, J. Stokes, *et al.*, "A Gasoline Engine Concept For Improved
Fuel Economy – The Lean-Boost System," SAE Paper 2001-01-2902. The use of these
techniques to increase engine efficiency, however, is limited by the onset of engine knock.
Knock is the undesired detonation of fuel and can severely damage an engine. If knock can be
15 prevented, then high compression ratio operation and high pressure boosting can be used to
increase engine efficiency by up to twenty-five percent.

Octane number represents the resistance of a fuel to knocking but the use of higher
octane gasoline only modestly alleviates the tendency to knock. For example, the difference
between regular and premium gasoline is typically six octane numbers. That is significantly less
20 than is needed to realize fully the efficiency benefits of high compression ratio or turbocharged
operation. There is thus a need for a practical means for achieving a much higher level of octane
enhancement so that engines can be operated much more efficiently.

It is known to replace a portion of gasoline with small amounts of ethanol added at the
refinery. Ethanol has a blending octane number (ON) of 110 (versus 95 for premium gasoline)
25 (see J.B. Heywood, "Internal Combustion Engine Fundamentals," McGraw Hill, 1988, p. 477)
and is also attractive because it is a renewable energy, biomass-derived fuel, but the small
amounts of ethanol that have heretofore been added to gasoline have had a relatively small
impact on engine performance. Ethanol is much more expensive than gasoline and the amount
of ethanol that is readily available is much smaller than that of gasoline because of the relatively
30 limited amount of biomass that is available for its production. An object of the present invention

is to minimize the amount of ethanol or other antiknock agent that is used to achieve a given level of engine efficiency increase. By restricting the use of ethanol to the relatively small fraction of time in an operating cycle when it is needed to prevent knock in a higher load regime and by minimizing its use at these times, the amount of ethanol that is required can be limited to
5 a relatively small fraction of the fuel used by the spark ignition gasoline engine.

Summary of the Invention

In one aspect, the invention is a fuel management system for efficient operation of a spark ignition gasoline engine including a source of an antiknock agent such as ethanol. An injector directly injects the ethanol into a cylinder of the engine and a fuel management system
10 controls injection of the antiknock agent into the cylinder to control knock with minimum use of the antiknock agent. A preferred antiknock agent is ethanol. Ethanol has a high heat of vaporization so that there is substantial cooling of the air-fuel charge to the cylinder when it is injected directly into the engine. This cooling effect reduces the octane requirement of the engine by a considerable amount in addition to the improvement in knock resistance from the
15 relatively high octane number of ethanol. Methanol, tertiary butyl alcohol, MTBE, ETBE, and TAME may also be used. Wherever ethanol is used herein it is to be understood that other antiknock agents are contemplated.

The fuel management system uses a fuel management control system that may use a microprocessor that operates in an open loop fashion on a predetermined correlation between
20 octane number enhancement and fraction of fuel provided by the antiknock agent. To conserve the ethanol, it is preferred that it be added only during portions of a drive cycle requiring knock resistance and that its use be minimized during these times. Alternatively, the gasoline engine may include a knock sensor that provides a feedback signal to a fuel management microprocessor system to minimize the amount of the ethanol added to prevent knock in a closed
25 loop fashion.

In one embodiment the injectors stratify the ethanol to provide non-uniform deposition within a cylinder. For example, the ethanol may be injected proximate to the cylinder walls and swirl can create a ring of ethanol near the walls.

In another embodiment of this aspect of the invention, the system includes a measure of
30 the amount of the antiknock agent such as ethanol in the source containing the antiknock agent to control turbocharging, supercharging or spark retard when the amount of ethanol is low.

The direct injection of ethanol provides substantially a 13°C drop in temperature for every ten percent of fuel energy provided by ethanol. An instantaneous octane enhancement of at least 4 octane numbers may be obtained for every 20 percent of the engine's energy coming from the ethanol.

5

Brief Description of the Drawing

Fig. 1 is a block diagram of one embodiment of the invention disclosed herein.

Fig. 2 is a graph of the drop in temperature within a cylinder as a function of the fraction of energy provided by ethanol.

10 **Fig. 3** is a schematic illustration of the stratification of cooler ethanol charge using direct injection and swirl motion for achieving thermal stratification.

Fig. 4 is a schematic illustration showing ethanol stratified in an inlet manifold.

Fig. 5 is a block diagram of an embodiment of the invention in which the fuel management microprocessor is used to control a turbocharger and spark retard based upon the amount of ethanol in a fuel tank.

15

Description of the Preferred Embodiment

With reference first to **Fig. 1**, a spark ignition gasoline engine **10** includes a knock sensor **12** and a fuel management microprocessor system **14**. The fuel management microprocessor system **14** controls the direct injection of an antiknock agent such as ethanol from an ethanol tank **16**. The fuel management microprocessor system **14** also controls the delivery of gasoline from a gasoline tank **18** into engine manifold **20**. A turbocharger **22** is provided to improve the torque and power density of the engine **10**. The amount of ethanol injection is dictated either by a predetermined correlation between octane number enhancement and fraction of fuel that is provided by ethanol in an open loop system or by a closed loop control system that uses a signal from the knock sensor **12** as an input to the fuel management microprocessor **14**. In both situations, the fuel management processor **14** will minimize the amount of ethanol added to a cylinder while still preventing knock. It is also contemplated that the fuel management microprocessor system **14** could provide a combination of open and closed loop control.

As show in **Fig. 1** it is preferred that ethanol be directly injected into the engine **10**. Direct injection substantially increases the benefits of ethanol addition and decreases the required

amount of ethanol. Recent advances in fuel injector and electronic control technology allows fuel injection directly into a spark ignition engine rather than into the manifold 20. Because ethanol has a high heat of vaporization there will be substantial cooling when it is directly injected into the engine 10. This cooling effect further increases knock resistance by a
5 considerable amount. In the embodiment of Fig. 1 port fuel injection of the gasoline in which the gasoline is injected into the manifold rather than directly injected into the cylinder is preferred because it is advantageous in obtaining good air/fuel mixing and combustion stability that are difficult to obtain with direct injection.

Ethanol has a heat of vaporization of 840kJ/kg, while the heat of vaporization of gasoline
10 is about 350kJ/kg. The attractiveness of ethanol increases when compared with gasoline on an energy basis, since the lower heating value of ethanol is 26.9MJ/kg while for gasoline it is about 44MJ/kg. Thus, the heat of vaporization per Joule of combustion energy is 0.031 for ethanol and 0.008 for gasoline. That is, for equal amounts of energy the required heat of vaporization of ethanol is about four times higher than that of gasoline. The ratio of the heat of vaporization per
15 unit air required for stoichiometric combustion is about 94 kJ/kg of air for ethanol and 24 kJ/kg of air for gasoline, or a factor of four smaller. Thus, the net effect of cooling the air charge is about four times lower for gasoline than for ethanol (for stoichiometric mixtures wherein the amount of air contains oxygen that is just sufficient to combust all of the fuel).

In the case of ethanol direct injection according to one aspect of the invention, the charge
20 is directly cooled. The amount of cooling due to direct injection of ethanol is shown in Fig. 2. It is assumed that the air/fuel mixture is stoichiometric without exhaust gas recirculation (EGR), and that gasoline makes up the rest of the fuel. It is further assumed that only the ethanol contributes to charge cooling. Gasoline is vaporized in the inlet manifold and does not contribute to cylinder charge cooling. The direct ethanol injection provides about 13°C of
25 cooling for each 10% of the fuel energy provided by ethanol. It is also possible to use direct injection of gasoline as well as direct injection of ethanol. However, under certain conditions there can be combustion stability issues.

The temperature decrement because of the vaporization energy of the ethanol decreases with lean operation and with EGR, as the thermal capacity of the cylinder charge increases. If

the engine operates at twice the stoichiometric air/fuel ratio, the numbers indicated in **Fig. 2** decrease by about a factor of 2 (the contribution of the ethanol itself and the gasoline is relatively modest). Similarly, for a 20% EGR rate, the cooling effect of the ethanol decreases by about 25%.

5 The octane enhancement effect can be estimated from the data in **Fig. 2**. Direct injection of gasoline results in approximately a five octane number decrease in the octane number required by the engine, as discussed by Stokes, *et al.* Thus the contribution is about five octane numbers per 30K drop in charge temperature. As ethanol can decrease the charge temperature by about 120K, then the decrease in octane number required by the engine due to the drop in temperature,
10 for 100% ethanol, is twenty octane numbers. Thus, when 100% of the fuel is provided by ethanol, the octane number enhancement is approximately thirty-five octane numbers with a twenty octane number enhancement coming from direct injection cooling and a fifteen octane number enhancement coming from the octane number of ethanol. From the above considerations, it can be projected that even if the octane enhancement from direct cooling is
15 significantly lower, a total octane number enhancement of at least 4 octane numbers should be achievable for every 20% of the total fuel energy that is provided by ethanol.

 Alternatively the ethanol and gasoline can be mixed together and then port injected through a single injector per cylinder, thereby decreasing the number of injectors that would be used. However, the air charge cooling benefit from ethanol would be lost.

20 Alternatively the ethanol and gasoline can be mixed together and then port fuel injected using a single injector per cylinder, thereby decreasing the number of injectors that would be used. However, the substantial air charge cooling benefit from ethanol would be lost. The volume of fuel between the mixing point and the port fuel injector should be minimized in order to meet the demanding dynamic octane-enhancement requirements of the engine.

25 Relatively precise determinations of the actual amount of octane enhancement from given amounts of direct ethanol injection can be obtained from laboratory and vehicle tests in addition to detailed calculations. These correlations can be used by the fuel management microprocessor system 14.

An additional benefit of using ethanol for octane enhancement is the ability to use it in a mixture with water. Such a mixture can eliminate the need for the costly and energy consuming water removal step in producing pure ethanol that must be employed when ethanol is added to gasoline at a refinery. Moreover, the water provides an additional cooling (due to vaporization) that further increases engine knock resistance. In contrast the present use of ethanol as an additive to gasoline at the refinery requires that the water be removed from the ethanol.

Since unlike gasoline, ethanol is not a good lubricant and the ethanol fuel injector can stick and not open, it is desirable to add a lubricant to the ethanol. The lubricant will also denature the ethanol and make it unattractive for human consumption.

Further decreases in the required ethanol for a given amount of octane enhancement can be achieved with stratification (non-uniform deposition) of the ethanol addition. Direct injection can be used to place the ethanol near the walls of the cylinder where the need for knock reduction is greatest. The direct injection may be used in combination with swirl. This stratification of the ethanol in the engine further reduces the amount of ethanol needed to obtain a given amount of octane enhancement. Because only the ethanol is directly injected and because it is stratified both by the injection process and by thermal centrifugation, the ignition stability issues associated with gasoline direct injection (GDI) can be avoided.

It is preferred that ethanol be added to those regions that make up the end-gas and are prone to auto-ignition. These regions are near the walls of the cylinder. Since the end-gas contains on the order of 25% of the fuel, substantial decrements in the required amounts of ethanol can be achieved by stratifying the ethanol.

In the case of the engine 10 having substantial organized motion (such as swirl), the cooling will result in forces that thermally stratify the discharge (centrifugal separation of the regions at different density due to different temperatures). The effect of ethanol addition is to increase gas density since the temperature is decreased. With swirl the ethanol mixture will automatically move to the zone where the end-gas is, and thus increase the anti-knock effectiveness of the injected ethanol. The swirl motion is not affected much by the compression stroke and thus survives better than tumble-like motion that drives turbulence towards top-dead-center (TDC) and then dissipates. It should be pointed out that relatively modest swirls result in

large separating (centrifugal) forces. A 3m/s swirl motion in a 5cm radius cylinder generates accelerations of about 200m/s^2 , or about 20g's.

Fig. 3 illustrates ethanol direct injection and swirl motion for achieving thermal stratification. Ethanol is predominantly on an outside region which is the end-gas region. Fig. 4 illustrates a possible stratification of the ethanol in an inlet manifold with swirl motion and thermal centrifugation maintaining stratification in the cylinder. In this case of port injection of ethanol, however, the advantage of substantial charge cooling may be lost.

With reference again to Fig. 2, the effect of ethanol addition all the way up to 100% ethanol injection is shown. At the point that the engine is 100% direct ethanol injected, there may be issues of engine stability when operating with only stratified ethanol injection that need to be addressed. In the case of stratified operation it may also be advantageous to stratify the injection of gasoline in order to provide a relatively uniform equivalence ratio across the cylinder (and therefore lower concentrations of gasoline in the regions where the ethanol is injected). This situation can be achieved, as indicated in Fig. 4, by placing fuel in the region of the inlet manifold that is void of ethanol.

The ethanol used in the invention can either be contained in a separate tank from the gasoline or may be separated from a gasoline/ethanol mixture stored in one tank.

The instantaneous ethanol injection requirement and total ethanol consumption over a drive cycle can be estimated from information about the drive cycle and the increase in torque (and thus increase in compression ratio, engine power density, and capability for downsizing) that is desired. A plot of the amount of operating time spent at various values of torque and engine speed in FTP and US06 drive cycles can be used. It is necessary to enhance the octane number at each point in the drive cycle where the torque is greater than permitted for knock free operation with gasoline alone. The amount of octane enhancement that is required is determined by the torque level.

A rough illustrative calculation shows that only a small amount of ethanol might be needed over the drive cycle. Assume that it is desired to increase the maximum torque level by a factor of two relative to what is possible without direct injection ethanol octane enhancement.

Information about the operating time for the combined FTP and US06 cycles shows that approximately only 10 percent of the time is spent at torque levels above 0.5 maximum torque and less than 1 percent of the time is spent above 0.9 maximum torque. Conservatively assuming that 100 % ethanol addition is needed at maximum torque and that the energy fraction of ethanol addition that is required to prevent knock decreases linearly to zero at 50 percent of maximum torque, the energy fraction provided by ethanol is about 30 percent. During a drive cycle about 20 percent of the total fuel energy is consumed at greater than 50 percent of maximum torque since during the 10 percent of the time that the engine is operated in this regime, the amount of fuel consumed is about twice that which is consumed below 50 percent of maximum torque. The amount of ethanol energy consumed during the drive cycle is thus roughly around 6 percent (30 percent x 0.2) of the total fuel energy.

In this case then, although 100% ethanol addition was needed at the highest value of torque, only 6% addition was needed averaged over the drive cycle. The ethanol is much more effectively used by varying the level of addition according to the needs of the drive cycle. Because of the lower heat of combustion of ethanol, the required amount of ethanol would be about 9% of the weight of the gasoline fuel or about 9% of the volume (since the densities of ethanol and gasoline are comparable). A separate tank with a capacity of about 1.8 gallons would then be required in automobiles with twenty gallon gasoline tanks. The stored ethanol content would be about 9% of that of gasoline by weight, a number not too different from present-day reformulated gasoline. Stratification of the ethanol addition could reduce this amount by more than a factor of two. An on-line ethanol distillation system might alternatively be employed but would entail elimination or reduction of the increase torque and power available from turbocharging.

Because of the relatively small amount of ethanol and present lack of an ethanol fueling infrastructure, it is important that the ethanol vehicle be operable if there is no ethanol on the vehicle. The engine system can be designed such that although the torque and power benefits would be lower when ethanol is not available, the vehicle could still be operable by reducing or eliminating turbocharging capability and/or by increasing spark retard so as to avoid knock. As shown in Fig. 5, the fuel management microprocessor system 14 uses ethanol fuel level in the ethanol tank 16 as an input to control the turbocharger 22 (or supercharger or spark retard, not

shown). As an example, with on-demand ethanol octane enhancement, a 4-cylinder engine can produce in the range of 280 horsepower with appropriate turbocharging or supercharging but could also be drivable with an engine power of 140 horsepower without the use of ethanol according to the invention.

5 The impact of a small amount of ethanol upon fuel efficiency through use in a higher efficiency engine can greatly increase the energy value of the ethanol. For example, gasoline consumption could be reduced by 20% due to higher efficiency engine operation from use of a high compression ratio, strongly turbocharged operation and substantial engine downsizing. The energy value of the ethanol, including its value in direct replacement of gasoline (5% of the
10 energy of the gasoline), is thus roughly equal to 25% of the gasoline that would have been used in a less efficient engine without any ethanol. The 5% gasoline equivalent energy value of ethanol has thus been leveraged up to a 25% gasoline equivalent value. Thus, ethanol can cost roughly up to five times that of gasoline on an energy basis and still be economically attractive. The use of ethanol as disclosed herein can be a much greater value use than in other ethanol
15 applications.

 Although the above discussion has featured ethanol as an exemplary anti-knock agent, the same approach can be applied to other high octane fuel and fuel additives with high vaporization energies such as methanol (with higher vaporization energy per unit fuel), and other anti-knock agents such as tertiary butyl alcohol, or ethers such as methyl tertiary butyl ether
20 (MTBE), ethyl tertiary butyl ether (ETBE), or tertiary amyl methyl ether (TAME).

 It is recognized that modifications and variations of the invention disclosed herein will be apparent to those of ordinary skill in the art and it is intended that all such modifications and variations be included within the scope of the appended claims.

 What is claimed is:

- 1 1. Fuel management system for efficient operation of a spark ignition gasoline engine
2 comprising:
3 a gasoline engine;
4 a source of an anti-knock agent;
5 an injector for direct injection of the anti-knock agent into a cylinder of the engine; and
6 a fuel management control system for controlling injection of the anti-knock agent into
7 the cylinder to control knock.
- 8 2. The system of claim 1 wherein the injectors stratify the anti-knock agent to provide non-
9 uniform deposition within a cylinder.
- 10 3. The system of claim 2 wherein the anti-knock agent is deposited near the walls of the
11 cylinder.
- 12 4. The system of claim 2 wherein the stratification is obtained through direct injection and
13 charge swirl.
- 14 5. The system of claim 1 wherein the anti-knock agent is selected from the group consisting
15 of ethanol, methanol, tertiary butyl alcohol, MTBE, ETBE and TAME.
- 16 6. The system of claim 1 wherein the fuel management system includes a microprocessor
17 that operates in an open loop fashion on a predetermined correlation between octane
18 number enhancement and fraction of fuel provided by the anti-knock agent.
- 19 7. The system of claim 1 wherein the gasoline engine includes a knock sensor providing a
20 feedback signal to a fuel management microprocessor to minimize the amount of the anti-
21 knock agent added to prevent knock in a closed loop fashion.
- 22 8. The system of claim 1 wherein the anti-knock agent is ethanol.
- 23 9. The system of claim 8 wherein the ethanol is mixed with water.

- 1 10. The system of claim 8 wherein the ethanol is mixed with a lubricant.
- 2 11. The system of claim 1 wherein the engine has substantial organized motion such as swirl.
- 3 12. The system of claim 1 wherein the system includes a measure of the amount of anti-
4 knock agent in the source to control turbocharging, supercharging or spark retard when
5 the amount of anti-knock agent is low.
- 6 13. The system of claim 1 wherein the anti-knock agent is added only during portions of a
7 drive cycle requiring knock resistance.
- 8 14. The system of claim 1 wherein gasoline is port injected into the engine.
- 9 15. The system of claim 1 wherein the gasoline is directly injected into the cylinder.
- 10 16. The system of claim 8 wherein the direct injection of ethanol provides substantially a
11 13°C drop in temperature for every 10% of fuel energy provided by the ethanol.
- 12 17. The system of claim 1 wherein the fuel management system substantially minimizes the
13 amount of anti-knock agent used over a drive cycle.
- 14 18. The system of claim 8 wherein an octane enhancement of at least 4 octane numbers is
15 obtained when 20% of the fuel energy in a cylinder comes from ethanol.
- 16 19. The system of claim 1 wherein turbocharging or supercharging are reduced or eliminated
17 and/or spark retard is increased when the anti-knock agent is not available.
- 18 20. The system of claim 8 wherein ethanol is injected proximate to a cylinder wall and swirl
19 creates a ring of ethanol.
- 20 21. Fuel management system for efficient operation of a spark ignition engine comprising:
21 a gasoline engine;
22 a source of anti-knock agent;
23 a means for port fuel injection of the anti-knock agent; and

1 a fuel management control system for controlling injection of the anti-knock agent into
2 the cylinder to control knock.

3 22. The system of claim 21 wherein the ethanol and gasoline are mixed together and then
4 port injected.

5 23. The system of claim 21 wherein the port injection is stratified.

6

Abstract of the Disclosure

Fuel management system for efficient operation of a spark ignition gasoline engine. Injectors inject an anti-knock agent such as ethanol directly into a cylinder of the engine. A fuel management microprocessor system controls injection of the anti-knock agent so as to control knock and minimize that amount of the anti-knock agent that is used in a drive cycle. It is preferred that the anti-knock agent is ethanol. The use of ethanol can be further minimized by injection in a non-uniform manner within a cylinder. The ethanol injection suppresses knock so that higher compression ratio and/or engine downsizing from increased turbocharging or supercharging can be used to increase the efficiency of the engine.

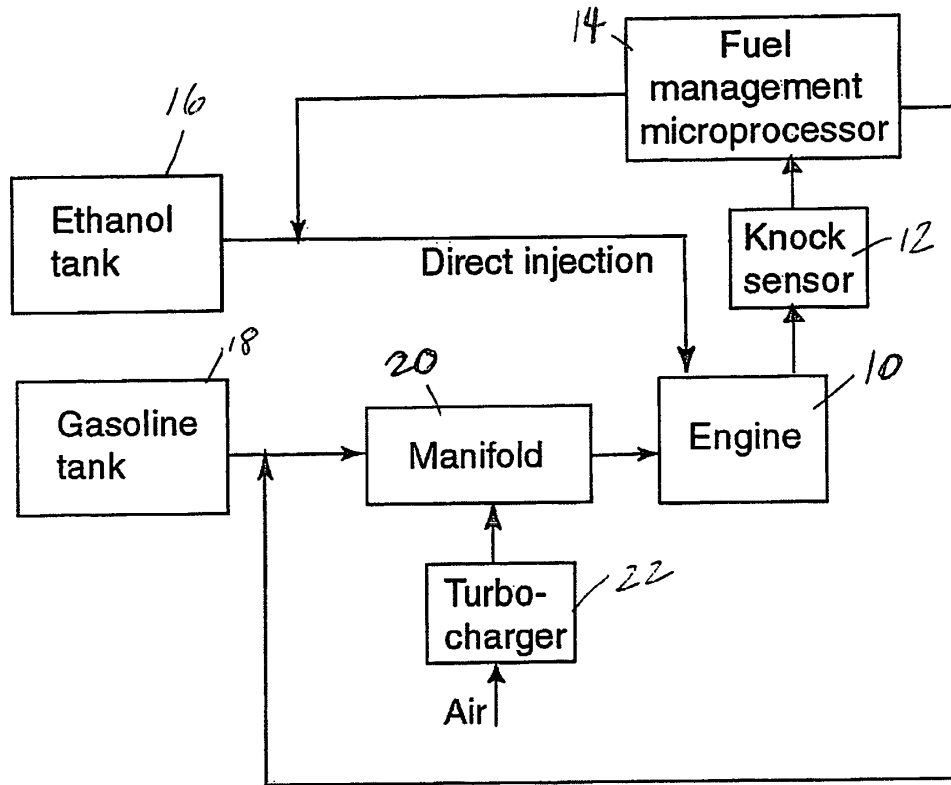

FIG. 1

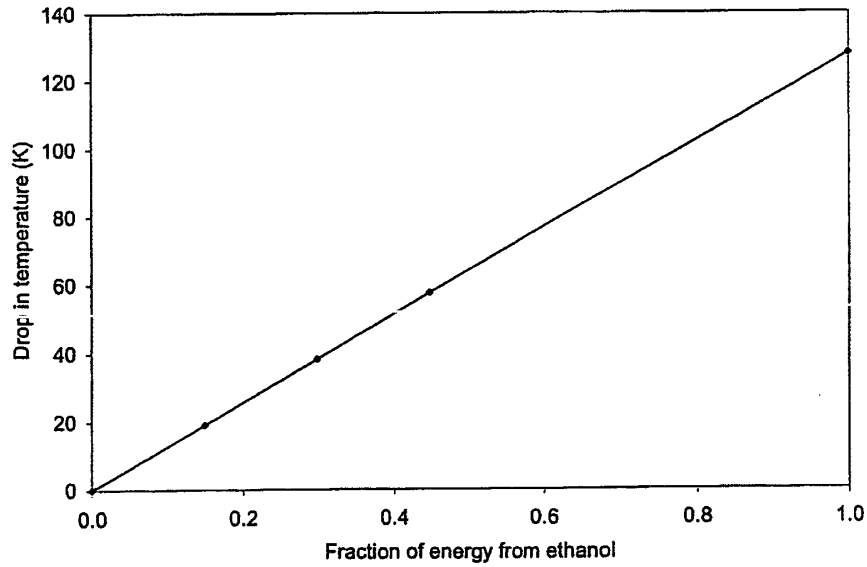
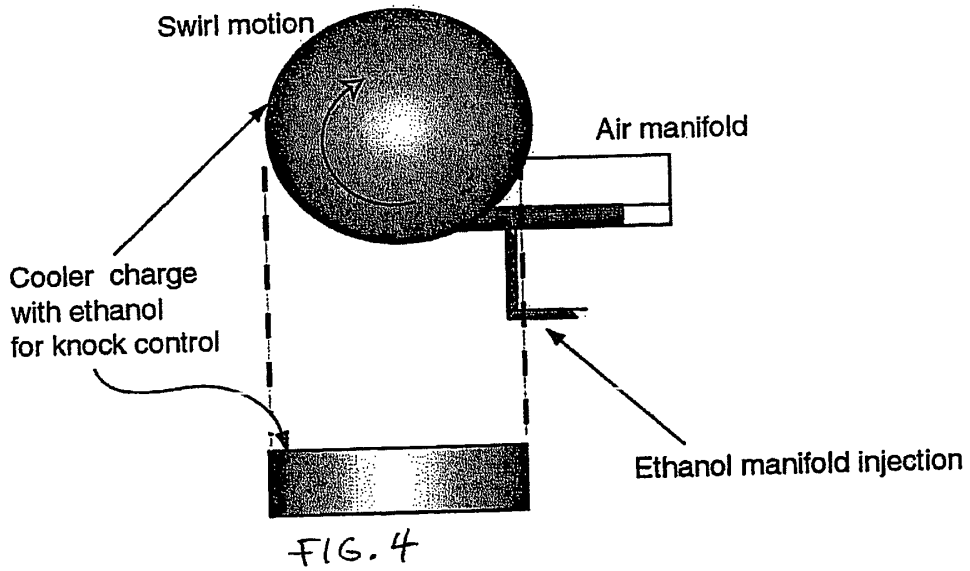
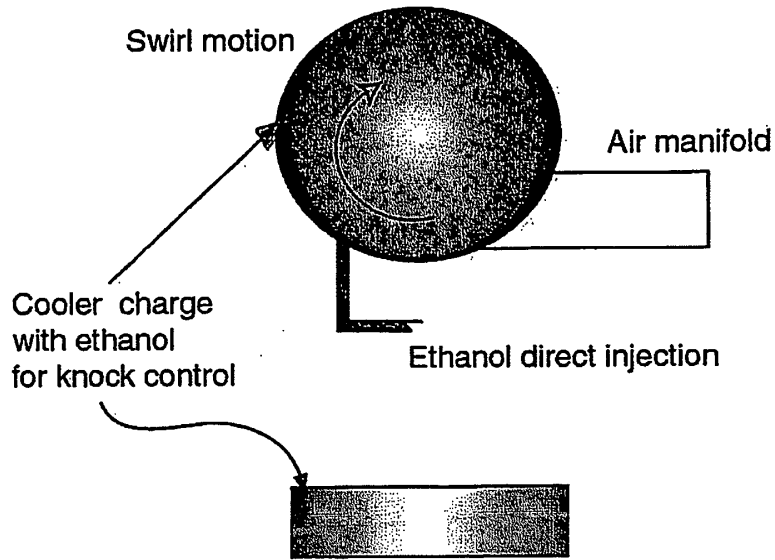

FIG. 2



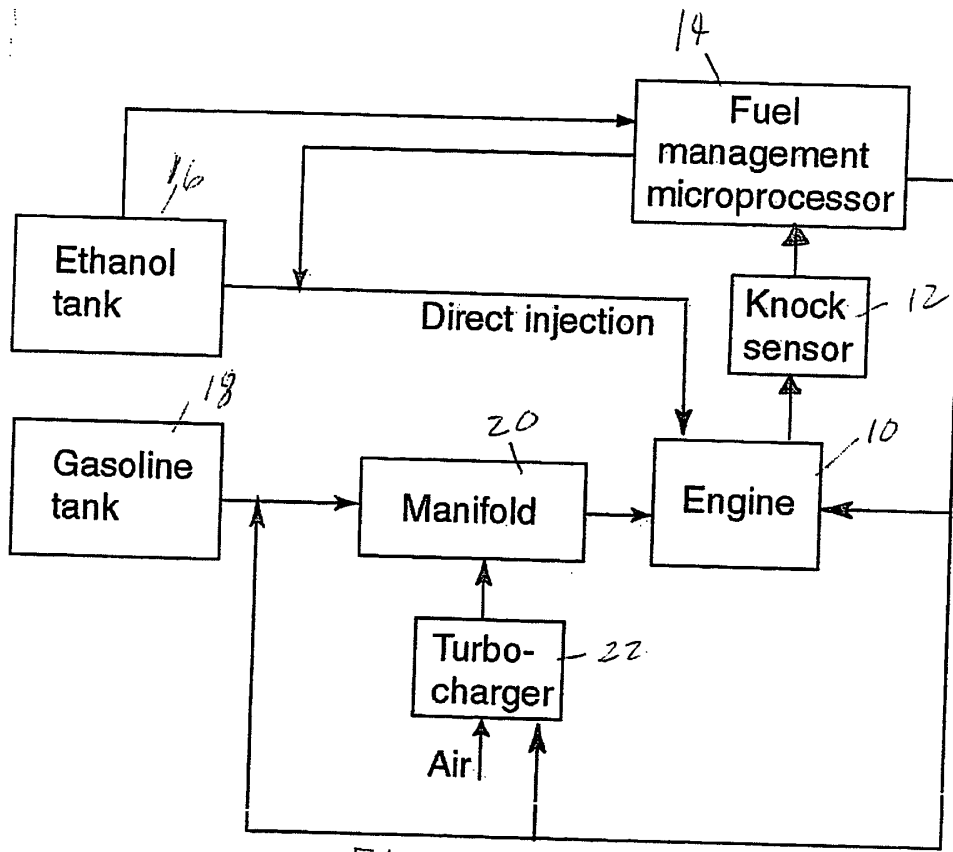

FIG. 5

PATENT APPLICATION SERIAL NO. _____

U.S. DEPARTMENT OF COMMERCE
PATENT AND TRADEMARK OFFICE
FEE RECORD SHEET

11/22/2004 SZEWDIE1 00000001 10991774

01 FC:2001	395.00 OP
02 FC:2202	27.00 OP

PTO-1556
(5/87)

*U.S. Government Printing Office: 2002 — 489-267/69033

PATENT APPLICATION FEE DETERMINATION RECORD
Effective October 1, 2004

Application or Docket Number

10991774

CLAIMS AS FILED - PART I

	(Column 1)	(Column 2)
TOTAL CLAIMS	23	
FOR	NUMBER FILED	NUMBER EXTRA
TOTAL CHARGEABLE CLAIMS	23 minus 20 =	* 3
INDEPENDENT CLAIMS	2 minus 3 =	*
MULTIPLE DEPENDENT CLAIM PRESENT <input type="checkbox"/>		

* If the difference in column 1 is less than zero, enter "0" in column 2

SMALL ENTITY TYPE

OR OTHER THAN SMALL ENTITY

RATE	FEE
BASIC FEE	395.00
X\$ 9=	27
X44=	
+150=	
TOTAL	422

RATE	FEE
BASIC FEE	790.00
X\$18=	
X88=	
+300=	
TOTAL	

CLAIMS AS AMENDED - PART II

	(Column 1)	(Column 2)	(Column 3)
AMENDMENT A	CLAIMS REMAINING AFTER AMENDMENT		HIGHEST NUMBER PREVIOUSLY PAID FOR
	Total	*	Minus
	Independent	*	Minus
FIRST PRESENTATION OF MULTIPLE DEPENDENT CLAIM <input type="checkbox"/>			

1 21

SMALL ENTITY OR

OTHER THAN SMALL ENTITY

RATE	ADDITIONAL FEE
X\$ 9=	
X44=	
+150=	
TOTAL ADDIT. FEE	

RATE	ADDITIONAL FEE
X\$18=	
X88=	
+300=	
TOTAL ADDIT. FEE	

	(Column 1)	(Column 2)	(Column 3)
AMENDMENT B	CLAIMS REMAINING AFTER AMENDMENT		HIGHEST NUMBER PREVIOUSLY PAID FOR
	Total	*	Minus
	Independent	*	Minus
FIRST PRESENTATION OF MULTIPLE DEPENDENT CLAIM <input type="checkbox"/>			

RATE	ADDITIONAL FEE
X\$ 9=	
X44=	
+150=	
TOTAL ADDIT. FEE	

RATE	ADDITIONAL FEE
X\$18=	
X88=	
+300=	
TOTAL ADDIT. FEE	

	(Column 1)	(Column 2)	(Column 3)
AMENDMENT C	CLAIMS REMAINING AFTER AMENDMENT		HIGHEST NUMBER PREVIOUSLY PAID FOR
	Total	*	Minus
	Independent	*	Minus
FIRST PRESENTATION OF MULTIPLE DEPENDENT CLAIM <input type="checkbox"/>			

RATE	ADDITIONAL FEE
X\$ 9=	
X44=	
+150=	
TOTAL ADDIT. FEE	

RATE	ADDITIONAL FEE
X\$18=	
X88=	
+300=	
TOTAL ADDIT. FEE	

* If the entry in column 1 is less than the entry in column 2, write "0" in column 3.
 ** If the "Highest Number Previously Paid For" IN THIS SPACE is less than 20, enter "20."
 *** If the "Highest Number Previously Paid For" IN THIS SPACE is less than 3, enter "3."
 The "Highest Number Previously Paid For" (Total or Independent) is the highest number found in the appropriate box in column 1.



AMENDMENT TRANSMITTAL LETTER	Docket Number 0492611-0598
-------------------------------------	-------------------------------

Application Number 10/991,774	Filing Date November 18, 2004	Examiner To Be Assigned	Group Art Unit To Be Assigned
----------------------------------	----------------------------------	----------------------------	----------------------------------

Invention Title
FUEL MANAGEMENT SYSTEM FOR VARIABLE ETHANOL OCTANE ENHANCEMENT OF GASOLINE ENGINES

TO THE COMMISSIONER FOR PATENTS

Transmitted herewith is an amendment in the above-identified application, including:

- (X) Preliminary Amendment
- (X) Return Postcard

CLAIMS AS AMENDED

	(1)		(2)	(3)		
	CLAIMS REMAINING AFTER AMENDMENT		HIGHEST NUMBER PREVIOUSLY PAID FOR	PRESENT NUMBER EXTRA	RATE	FEE
TOTAL CLAIMS	53		20	33	x \$ 50	\$1,650
INDEPENDENT CLAIMS	2	Minus	3	0	x \$200	\$
MULTIPLE DEPENDENT CLAIM ADDED					\$360	\$
					TOTAL	\$1,650
If applicant has small entity status under 37 CFR 1.9 and 1.27, then divide total fee by 2, and enter amount here.				SMALL ENTITY TOTAL		\$ 825

* If the entry in column 1 is less than the entry in column 2, write "0" in column 3.
 ** If the highest number previously paid for IN THIS SPACE is less than 20, enter "20."
 *** If the highest number previously paid for IN THIS SPACE is less than 3, enter "3."
 The "highest number previously paid for" (total or independent) is the highest number found in the appropriate box in column 1.

- () Please charge **Deposit Account Number 03-1721** in the amount of \$_____. A duplicate copy of this sheet is enclosed.
- (X) A check in the amount of \$825.00 to cover the filing fee is enclosed.
- (X) Please credit any overpayment and/or charge any additional filing fees required under 37 CFR §§ 1.16 and 1.17 to our **Deposit Account Number 03-1721**.

I hereby certify that this correspondence is being deposited with the United States Postal Service as first class mail in an envelope addressed to: Mail Stop Amendment, Commissioner for Patents, P.O. Box 1450, Alexandria, VA 22313-1450, on December 22, 2004.

Cathy A. O'Brien
Cathy A. O'Brien

Sam Pasternack
 Sam Pasternack, Reg. No. 29,576
 December 22, 2004
 Date



JPW

THE UNITED STATES PATENT AND TRADEMARK OFFICE

Applicant:	Daniel R. Cohn, et al.	:	
		:	
Serial No.:	10/991,774	:	Examiner: To Be Assigned
		:	
Filed:	November 18, 2004	:	Art Unit: To Be Assigned
		:	
For:	FUEL MANAGEMENT SYSTEM FOR VARIABLE ETHANOL OCTANE ENHANCEMENT OF GASOLINE ENGINES	:	Atty. Docket: 0492611-0598
		:	
		:	

Certificate of Mailing

I hereby certify that the foregoing document is being deposited with the United States Postal Service, postage prepaid, in an envelope addressed to Mail Stop Amendment, Commissioner for Patents, P.O. Box 1450, Alexandria, VA 22313-1450 on December 22, 2004.

Name: Cathy A. O'Brien

PRELIMINARY AMENDMENT

Mail Stop Amendment
Commissioner for Patents
P.O. Box 1450
Alexandria, VA 22313-1450

Sir:

Please preliminary amend the above-identified application as follows.

Amendments to the Specification begin on page 2 of this paper.

Amendments to the Claims are reflected in the listing of claims which begin on page 3 of this paper.

Remarks/Arguments begin on page 8 of this paper.

12/29/2004 HALI11 00000027 10991774
01 FC:2202 825.00 OP

3781330v1



AMENDMENT TRANSMITTAL LETTER	Docket Number 0492611-0598
-------------------------------------	-------------------------------

Application Number 10/991,774	Filing Date November 18, 2004	Examiner To Be Assigned	Group Art Unit To Be Assigned
----------------------------------	----------------------------------	----------------------------	----------------------------------

Invention Title
FUEL MANAGEMENT SYSTEM FOR VARIABLE ETHANOL OCTANE ENHANCEMENT OF GASOLINE ENGINES

TO THE COMMISSIONER FOR PATENTS

Transmitted herewith is an amendment in the above-identified application, including:

- (X) Preliminary Amendment
- (X) Return Postcard

CLAIMS AS AMENDED

	(1)		(2)	(3)		
	CLAIMS REMAINING AFTER AMENDMENT		HIGHEST NUMBER PREVIOUSLY PAID FOR	PRESENT NUMBER EXTRA	RATE	FEE
TOTAL CLAIMS	53		20	33	x \$ 50	\$1,650
INDEPENDENT CLAIMS	2	Minus	3	0	x \$200	\$
MULTIPLE DEPENDENT CLAIM ADDED					\$360	\$
					TOTAL	\$1,650
If applicant has small entity status under 37 CFR 1.9 and 1.27, then divide total fee by 2, and enter amount here.				SMALL ENTITY TOTAL		\$ 825

* If the entry in column 1 is less than the entry in column 2, write "0" in column 3.
 ** If the highest number previously paid for IN THIS SPACE is less than 20, enter "20."
 *** If the highest number previously paid for IN THIS SPACE is less than 3, enter "3."
 The "highest number previously paid for" (total or independent) is the highest number found in the appropriate box in column 1.

- () Please charge **Deposit Account Number 03-1721** in the amount of \$_____. A duplicate copy of this sheet is enclosed.
- (X) A check in the amount of \$825.00 to cover the filing fee is enclosed.
- (X) Please credit any overpayment and/or charge any additional filing fees required under 37 CFR §§ 1.16 and 1.17 to our **Deposit Account Number 03-1721**.

I hereby certify that this correspondence is being deposited with the United States Postal Service as first class mail in an envelope addressed to: Mail Stop Amendment, Commissioner for Patents, P.O. Box 1450, Alexandria, VA 22313-1450, on December 22, 2004.

Cathy A. O'Brien
Cathy A. O'Brien

Sam Pasternack
 Sam Pasternack, Reg. No. 29,576
 December 22, 2004
 Date



JPW

THE UNITED STATES PATENT AND TRADEMARK OFFICE

Applicant:	Daniel R. Cohn, et al.	:	
		:	
Serial No.:	10/991,774	:	Examiner: To Be Assigned
		:	
Filed:	November 18, 2004	:	Art Unit: To Be Assigned
		:	
For:	FUEL MANAGEMENT SYSTEM FOR VARIABLE ETHANOL OCTANE ENHANCEMENT OF GASOLINE ENGINES	:	Atty. Docket: 0492611-0598
		:	
		:	

Certificate of Mailing

I hereby certify that the foregoing document is being deposited with the United States Postal Service, postage prepaid, in an envelope addressed to Mail Stop Amendment, Commissioner for Patents, P.O. Box 1450, Alexandria, VA 22313-1450 on December 22, 2004.

Name: Cathy A. O'Brien

PRELIMINARY AMENDMENT

Mail Stop Amendment
Commissioner for Patents
P.O. Box 1450
Alexandria, VA 22313-1450

Sir:

Please preliminary amend the above-identified application as follows.

Amendments to the Specification begin on page 2 of this paper.

Amendments to the Claims are reflected in the listing of claims which begin on page 3 of this paper.

Remarks/Arguments begin on page 8 of this paper.

12/29/2004 HALI11 00000027 10991774
01 FC:2202 825.00 OP

3781330v1

AMENDMENTS TO THE SPECIFICATION

Please delete the paragraph beginning at page 6, line 17, which starts “Alternatively the ethanol.”

AMENDMENTS TO THE CLAIMS:

This listing of claims will replace all prior versions and listing of claims in the above-referenced application.

Listing of Claims:

1. (currently amended) Fuel management system for ~~efficient~~ operation of a spark ignition gasoline engine comprising:
 - a gasoline engine;
 - a source of an anti-knock agent;
 - an injector for direct injection of the anti-knock agent into a cylinder of the engine; and
 - a fuel management control system for controlling injection of the anti-knock agent into the cylinder to control knock.

2. (currently amended) The system of claim 1 wherein the injectors ~~stratify~~ deposit the anti-knock agent to provide non-uniform deposition within a cylinder.

3. (original) The system of claim 2 wherein the anti-knock agent is deposited near the walls of the cylinder.

4. (currently amended) The system of claim 2 wherein the ~~stratification~~ non-uniform deposition is obtained through direct injection and charge swirl.

5. (original) The system of claim 1 wherein the anti-knock agent is selected from the group consisting of ethanol, methanol, tertiary butyl alcohol, MTBE, ETBE and TAME.

6. (currently amended) The system of claim 1 wherein the fuel management system includes a microprocessor that operates in an open loop fashion on a predetermined correlation between required octane number enhancement and fraction of fuel provided by the anti-knock agent.

7. (original) The system of claim 1 wherein the gasoline engine includes a knock sensor providing a feedback signal to a fuel management microprocessor to minimize the amount of the anti-knock agent added to prevent knock in a closed loop fashion.

8. (original) The system of claim 1 wherein the anti-knock agent is ethanol.

9. (original) The system of claim 8 wherein the ethanol is mixed with water.
10. (original) The system of claim 8 wherein the ethanol is mixed with a lubricant.
11. (original) The system of claim 1 wherein the engine has substantial organized motion such as swirl.
12. (original) The system of claim 1 wherein the system includes a measure of the amount of anti-knock agent in the source to control turbocharging, supercharging or spark retard when the amount of anti-knock agent is low.
13. (original) The system of claim 1 wherein the anti-knock agent is added only during portions of a drive cycle requiring knock resistance.
14. (original) The system of claim 1 wherein gasoline is port injected into the engine.
15. (original) The system of claim 1 wherein the gasoline is directly injected into the cylinder.
16. (original) The system of claim 8 wherein the direct injection of ethanol provides substantially a 13°C drop in temperature for every 10% of fuel energy provided by the ethanol.
17. (original) The system of claim 1 wherein the fuel management system substantially minimizes the amount of anti-knock agent used over a drive cycle.
18. (original) The system of claim 8 wherein an octane enhancement of at least 4 octane numbers is obtained when 20% of the fuel energy in a cylinder comes from ethanol.
19. (original) The system of claim 1 wherein turbocharging or supercharging are reduced or eliminated and/or spark retard is increased when the anti-knock agent is not available.
20. (original) The system of claim 8 wherein ethanol is injected proximate to a cylinder wall and swirl creates a ring of ethanol.
- 21-23. (cancelled)

24. (new) The system of claim 8 wherein the engine is operated with substantially a stoichiometric air/fuel ratio.
25. (new) The system of claim 8 wherein the ethanol is added only during portions of the drive cycle requiring knock resistance and its use is minimized during those times.
26. (new) The system of claim 8 wherein the ethanol is separated from a gasoline/ethanol mixture.
27. (new) The system of claim 8 wherein torque of the engine at which knock occurs can be increased by at least a factor of two by the direct injection of ethanol.
28. (new) The system of claim 8 wherein horsepower of a given size engine can be at least doubled by using ethanol octane enhancement.
29. (new) The system of claim 8 wherein gasoline consumption is reduced by at least 20% due to higher efficiency engine operation.
30. (new) Fuel management system for operation of a spark ignition gasoline engine comprising:
 - a gasoline engine;
 - a source of ethanol;
 - an injector for direct injection of the ethanol into a cylinder of the engine; and
 - a fuel management control system for controlling injection of the ethanol into the cylinder when engine torque is above a selected fraction of maximum torque.
31. (new) The system of claim 30 wherein torque levels at which the ethanol is directly injected are those where knock would occur absent the ethanol injection.
32. (new) The system of claim 30 wherein the fraction of total fuel provided by the directly injected ethanol increases with increasing torque.
33. (new) The system of claim 30 wherein gasoline is port fuel injected.
34. (new) The system of claim 30 wherein up to and including substantially 100% of the fuel can be provided by the ethanol.
35. (new) The system of claim 30 wherein octane number is enhanced with increasing torque.
36. (new) The system of claim 30 wherein an octane enhancement of more than 20 octane numbers is achieved.

37. (new) The system of claim 30 wherein the fuel management system includes a microprocessor that operates in an open loop fashion on a predetermined correlation between the required octane number enhancement and fraction of fuel provided by the ethanol.
38. (new) The system of claim 30 wherein the gasoline engine includes a knock sensor providing a feedback signal to a fuel management microprocessor to minimize the amount of the ethanol added to prevent knock in a closed loop fashion.
39. (new) The system of claim 30 wherein the injector provides non-uniform deposition of the ethanol within a cylinder.
40. (new) The system of claim 39 wherein the ethanol is deposited near the walls of the cylinder.
41. (new) The system of claim 39 wherein the non-uniform deposition is obtained through direct injection and charge swirl.
42. (new) The system of claim 30 wherein the ethanol is mixed with water.
43. (new) The system of claim 30 wherein the ethanol is mixed with a lubricant.
44. (new) The system of claim 30 wherein the engine has substantial organized motion such as swirl.
45. (new) The system of claim 30 wherein the system includes a measure of the amount of ethanol available to control turbocharging, supercharging or spark retard when the amount of ethanol is low.
46. (new) The system of claim 30 wherein the gasoline is directly injected into the cylinder.
47. (new) The system of claim 30 wherein the direct injection of ethanol provides substantially a 13°C drop in temperature for every 10% of the fuel energy provided by the ethanol.
48. (new) The system of claim 30 wherein the fuel management system substantially minimizes the amount of ethanol used over a drive cycle.
49. (new) The system of claim 30 wherein an octane enhancement of at least four octane numbers is obtained when 20% of the fuel energy in a cylinder comes from ethanol.
50. (new) The system of claim 30 wherein turbocharging or supercharging are reduced or eliminated and/or spark retard is increased when ethanol is not available.
51. (new) The system of claim 30 wherein the engine is operated with substantially a stoichiometric fuel/air ratio.

52. (new) The system of claim 30 wherein the ethanol is separated from a gasoline/ethanol mixture.
53. (new) The system of claim 30 wherein the engine can be operated with only gasoline and knock can be avoided by reducing the maximum torque and horsepower relative to values when ethanol is directly injected into the cylinder.
54. (new) The system of claim 53 wherein the horsepower is reduced by at least a factor of two.
55. (new) The system of claim 30 wherein the fuel management microprocessor control system uses ethanol level in the ethanol tank as an input to control a turbocharger, supercharger or spark retard.
56. (new) The system of claim 55 wherein the turbocharger, supercharger or spark retard is adjusted to prevent knock.

REMARKS

The specification has been amended to delete two sentences that had been inadvertently duplicated.

It is requested that the claims amended herein be introduced into the application. No new matter is being introduced by these amended claims in that support is found throughout the application. Specific support for the new claim language will now be provided.

Support for claim 24 may be found in the specification at page 5, line 21. The language of claim 25 is supported at page 3, beginning at line 21. Support for claim 26 may be found at page 8, line 17. Claim 27 is supported at page 8, last line. Claim 28 is supported at page 10, lines 1-4. Claim 29 is supported at page 10, line 7.

The language of claim 30 is supported in the specification at page 3, line 3 and at page 9 beginning at line 3. Similarly, claim 31 is also supported at page 3, line 3.

Claim 32 is supported at page 9, beginning at line 3. Claim 36 is supported at page 6, line 10. The remaining claims are modeled on claims as originally filed.

Claim 53 is supported at page 9, line 26. Claim 54 is supported at page 10 beginning at line 1. Support for claims 55 and 56 may be found on page 9 at line 28.

It is requested that these claims be entered into the patent application and be examined in due course.

Respectfully submitted,



Sam Pasternack
Registration No. 29,576

Date: December 22, 2004

Patent Department
CHOATE, HALL & STEWART
Exchange Place
53 State Street
Boston, MA 02109-2804
Tel: (617) 248-5000
Fax: (617) 248-4000

PATENT APPLICATION FEE DETERMINATION RECORD
Effective October 1, 2004

Application or Docket Number

10991774

CLAIMS AS FILED - PART I

	(Column 1)	(Column 2)
TOTAL CLAIMS	23	
FOR	NUMBER FILED	NUMBER EXTRA
TOTAL CHARGEABLE CLAIMS	23 minus 20=	3
INDEPENDENT CLAIMS	2 minus 3 =	
MULTIPLE DEPENDENT CLAIM PRESENT <input type="checkbox"/>		

* If the difference in column 1 is less than zero, enter "0" in column 2

SMALL ENTITY TYPE OR OTHER THAN SMALL ENTITY

RATE	FEE	OR	RATE	FEE
BASIC FEE	395.00	OR	BASIC FEE	790.00
X\$ 9=	27	OR	X\$18=	
X44=		OR	X88=	
+150=		OR	+300=	
TOTAL	422	OR	TOTAL	

CLAIMS AS AMENDED - PART II

	(Column 1)	(Column 2)	(Column 3)
AMENDMENT A	CLAIMS REMAINING AFTER AMENDMENT	HIGHEST NUMBER PREVIOUSLY PAID FOR	PRESENT EXTRA
	6-27-04		
Total	53	Minus	** 23 = 33
Independent	2	Minus	*** 2 = 0
FIRST PRESENTATION OF MULTIPLE DEPENDENT CLAIM <input type="checkbox"/>			

1 21

SMALL ENTITY OR OTHER THAN SMALL ENTITY

RATE	ADDITIONAL FEE	OR	RATE	ADDITIONAL FEE
X\$ 9=	825	OR	X\$18=	
X44=		OR	X88=	
+150=		OR	+300=	
TOTAL ADDIT. FEE	825	OR	TOTAL ADDIT. FEE	

	(Column 1)	(Column 2)	(Column 3)
AMENDMENT B	CLAIMS REMAINING AFTER AMENDMENT	HIGHEST NUMBER PREVIOUSLY PAID FOR	PRESENT EXTRA
Total		Minus	** =
Independent		Minus	*** =
FIRST PRESENTATION OF MULTIPLE DEPENDENT CLAIM <input type="checkbox"/>			

RATE	ADDITIONAL FEE	OR	RATE	ADDITIONAL FEE
X\$ 9=		OR	X\$18=	
X44=		OR	X88=	
+150=		OR	+300=	
TOTAL ADDIT. FEE		OR	TOTAL ADDIT. FEE	

	(Column 1)	(Column 2)	(Column 3)
AMENDMENT C	CLAIMS REMAINING AFTER AMENDMENT	HIGHEST NUMBER PREVIOUSLY PAID FOR	PRESENT EXTRA
Total		Minus	** =
Independent		Minus	*** =
FIRST PRESENTATION OF MULTIPLE DEPENDENT CLAIM <input type="checkbox"/>			

RATE	ADDITIONAL FEE	OR	RATE	ADDITIONAL FEE
X\$ 9=		OR	X\$18=	
X44=		OR	X88=	
+150=		OR	+300=	
TOTAL ADDIT. FEE		OR	TOTAL ADDIT. FEE	

* If the entry in column 1 is less than the entry in column 2, write "0" in column 3.
 ** If the "Highest Number Previously Paid For" IN THIS SPACE is less than 20, enter "20."
 *** If the "Highest Number Previously Paid For" IN THIS SPACE is less than 3, enter "3."
 The "Highest Number Previously Paid For" (Total or Independent) is the highest number shown in the appropriate box in column 1.



UNITED STATES PATENT AND TRADEMARK OFFICE

UNITED STATES DEPARTMENT OF COMMERCE
United States Patent and Trademark Office
Address: COMMISSIONER FOR PATENTS
P.O. Box 1450
Alexandria, Virginia 22313-1450
www.uspto.gov

APPLICATION NUMBER	FILING OR 371 (c) DATE	FIRST NAMED APPLICANT	ATTORNEY DOCKET NUMBER
10/991,774	11/18/2004	Daniel R. Cohn	0492611-0598

24280
CHOATE, HALL & STEWART LLP
EXCHANGE PLACE
53 STATE STREET
BOSTON, MA 02109

CONFIRMATION NO. 8282

FORMALITIES LETTER



OC000000015308213

Date Mailed: 03/01/2005

NOTICE TO FILE MISSING PARTS OF NONPROVISIONAL APPLICATION

FILED UNDER 37 CFR 1.53(b)

Filing Date Granted

Items Required To Avoid Abandonment:

An application number and filing date have been accorded to this application. The item(s) indicated below, however, are missing. Applicant is given **TWO MONTHS** from the date of this Notice within which to file all required items and pay any fees required below to avoid abandonment. Extensions of time may be obtained by filing a petition accompanied by the extension fee under the provisions of 37 CFR 1.136(a).

- The oath or declaration is missing.
A properly signed oath or declaration in compliance with 37 CFR 1.63, identifying the application by the above Application Number and Filing Date, is required.
- To avoid abandonment, a late filing fee or oath or declaration surcharge as set forth in 37 CFR 1.16(e) of \$65 for a small entity in compliance with 37 CFR 1.27, must be submitted with the missing items identified in this letter.

SUMMARY OF FEES DUE:

Total additional fee(s) required for this application is **\$65** for a Small Entity

- **\$65** Late oath or declaration Surcharge.

Replies should be mailed to: Mail Stop Missing Parts
Commissioner for Patents
P.O. Box 1450
Alexandria VA 22313-1450

*A copy of this notice **MUST** be returned with the reply.*



Customer Service Center
Initial Patent Examination Division (703) 308-1202

PART 3 - OFFICE COPY



IFW

UNITED STATES PATENT AND TRADEMARK OFFICE

UNITED STATES DEPARTMENT OF COMMERCE
United States Patent and Trademark Office
Address: COMMISSIONER FOR PATENTS
P.O. Box 1450
Alexandria, Virginia 22313-1450
www.uspto.gov

APPLICATION NUMBER	FILING OR 371 (e) DATE	FIRST NAMED APPLICANT	ATTORNEY DOCKET NUMBER
10/991,774	11/18/2004	Daniel R. Cohn	0492611-0598

24280
CHOATE, HALL & STEWART LLP
EXCHANGE PLACE
53 STATE STREET
BOSTON, MA 02109

CONFIRMATION NO. 8282

FORMALITIES LETTER



OC000000015308213

03/22/2005 HDEMESS1 00000003 10991774

01 FC:2051

65.00 OP

Date Mailed: 03/01/2005

NOTICE TO FILE MISSING PARTS OF NONPROVISIONAL APPLICATION

FILED UNDER 37 CFR 1.53(b)

Filing Date Granted

Items Required To Avoid Abandonment:

An application number and filing date have been accorded to this application. The item(s) indicated below, however, are missing. Applicant is given **TWO MONTHS** from the date of this Notice within which to file all required items and pay any fees required below to avoid abandonment. Extensions of time may be obtained by filing a petition accompanied by the extension fee under the provisions of 37 CFR 1.136(a).

- The oath or declaration is missing.
A properly signed oath or declaration in compliance with 37 CFR 1.63, identifying the application by the above Application Number and Filing Date, is required.
- To avoid abandonment, a late filing fee or oath or declaration surcharge as set forth in 37 CFR 1.16(e) of \$65 for a small entity in compliance with 37 CFR 1.27, must be submitted with the missing items identified in this letter.

SUMMARY OF FEES DUE:

Total additional fee(s) required for this application is **\$65** for a Small Entity

- **\$65** Late oath or declaration Surcharge.

Replies should be mailed to: Mail Stop Missing Parts
Commissioner for Patents
P.O. Box 1450
Alexandria VA 22313-1450

*A copy of this notice **MUST** be returned with the reply.*

[Handwritten signature]

Customer Service Center

Initial Patent Examination Division (703) 308-1202

PART 2 - COPY TO BE RETURNED WITH RESPONSE



IN THE UNITED STATES PATENT AND TRADEMARK OFFICE

Applicant:	Cohn, <i>et al.</i>	:	
		:	
Serial No.:	10/991,774	:	Examiner: Not Yet Assigned
		:	
Filed:	November 18, 2004	:	Art Unit: 1714
		:	
For:	FUEL MANAGEMENT SYSTEM	:	Atty. Docket: 0492611-0598
	FOR VARIABLE ETHANOL	:	
	OCTANE ENHANCEMENT OF	:	
	GASOLINE ENGINES	:	

Certificate of Mailing

I hereby certify that the foregoing document is being deposited with the United States Postal Service, postage prepaid, first class mail, in an envelope addressed to Mail Stop Missing Parts, Commissioner for Patents, P.O. Box 1450, Alexandria, VA 22313-1450 on this 17th day of March, 2005.

Name: Cathy A. O'Brien

RESPONSE TO NOTICE TO FILE MISSING PARTS

Mail Stop Missing Parts
Commissioner for Patents
P.O. Box 1450
Alexandria, VA 22313-1450

Sir:

In response to the Notice to File Missing Parts mailed March 1, 2005 for the above-referenced patent application under 35 U.S.C. 371, Applicant respectfully submits the following:

1. An executed Declaration;
2. Appointment of Attorney;
3. Establishing Right of Assignee to Take Action (37 CFR § 3.73(b));
4. A copy of the Notice to File Missing Parts;

3879637v1

5. A check in the amount of \$65.00 to cover the missing parts surcharge for a small entity;

6. Return postcard.

Although we believe that we have appropriately provided for any fees due in connection with this submission, the Commissioner is authorized to credit any overpayment or charge any deficiencies to/from our **Deposit Account No. 03-1721**. A duplicate copy of this form is being submitted.

Should there be any questions after reviewing this paper, the Examiner is invited to contact the undersigned at (617) 248-5143.

Respectfully submitted,
CHOATE, HALL & STEWART LLP

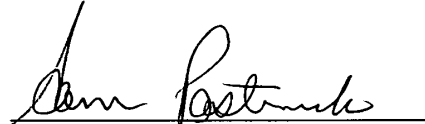

Sam Pasternack
Registration No. 29,576

Date: March 17, 2005

Patent Group
CHOATE, HALL & STEWART LLP
Exchange Place
53 State Street
Boston, MA 02109-2804
Tel: (617) 248-5000
Fax: (617) 248-4000



DECLARATION

As a below named inventor, I hereby declare that:

My residence, post office address and citizenship are as stated below next to my name,

I believe I am an original, first and joint inventor of the subject matter which is claimed and for which a patent is sought on the invention entitled:

FUEL MANAGEMENT SYSTEM FOR VARIABLE ETHANOL OCTANE ENHANCEMENT OF GASOLINE ENGINES

the specification of which (I authorize Choate, Hall & Stewart to check one of the following three choices, and fill in the blanks, if applicable):

_____ is attached hereto

X was filed on November 18, 2004 as Application Serial No. 10/991,774 and amended on _____ (if applicable).

_____ was filed as PCT international application No. _____, on _____ and was amended under PCT Article 19 on _____ (if applicable).

I hereby state that I have reviewed and understood the contents of the above-identified specification, including the claims, as amended by any amendment referred to above.

I acknowledged the duty to disclose information which is material to the examination of this application in accordance with Title 37, Code of Federal Regulations, §1.56.

I hereby claim foreign priority benefits under Title 35, United States Code, §119 of any foreign application(s) for patent or inventor's certificate listed below and have also identified below any foreign application for patent or inventor's certificate having a filing date before that of the application on which priority is claimed:

Table with 4 columns: Prior Foreign Application(s), Priority Claimed, (Number), (Country), (Day/Month/Year/Filed), Yes, No. Two rows of empty fields for data entry.

I hereby claim the benefit under Title 35, United States Code, §120 of any United States application(s) or PCT international application(s) designating the United States of America listed below and, insofar as the subject matter of each of the claims of this application is not disclosed in the prior United States application in the manner provided by the first paragraph of Title 35, United States Code, §112, I acknowledge the duty to disclose material information as defined in Title 37, Code of Federal Regulations, §1.56 which became available between the filing date of the prior application and the national or PCT international filing date of this application:

_____	_____	_____
(Application Serial No.)	(filing date)	(status-patented, pending, abandoned)

_____	_____	_____
(Application Serial No.)	(filing date)	(status-patented, pending, abandoned)

PCT Applications designating the United States:

_____	_____	_____
(PCT Appl. No.)	(U.S.S.N.)	(status-patented, pending, abandoned)

I hereby claim the benefit under Title 35, United States Code, §119(e) of any United States provisional application(s) listed below and, insofar as the subject matter of each of the claims of this application is not disclosed in the prior United States application in the manner provided by the first paragraph of Title 35, United States Code, §112, I acknowledge the duty to disclose information which is material to patentability as defined in Title 37, Code of Federal Regulations, §1.56 which became available between the filing date of the prior application and the national filing date of this application.

Provisional Application(s):

_____	_____	_____
(Application Serial No.)	(filing date)	(status)

_____	_____	_____
(Application Serial No.)	(filing date)	(status)

I hereby declare that all statements made herein of my own knowledge are true and that all statements made on information and belief are believed to be true; and further that these statements were made with the knowledge that willful false statements and the like so made are punishable by fine or imprisonment, or both, under Section 1001 of Title 18 of the United State Code and that such willful false statements may jeopardize the validity of the application or any patents issued thereon.

Full name of first inventor Daniel R. Cohn

Inventor's signature Daniel R. Cohn Date: 2/7/05

Residence 26 Walnut St Chestnut Hill MA 02467

Citizenship _____

Post Office Address Technology Licensing Office, Massachusetts Institute of Technology,
Five Cambridge Center, Kendall Square, Room NE25-230, Cambridge, MA 02142-1493

Full name of second inventor Leslie Bromberg

Inventor's signature Leslie Bromberg Date: 2/7/05

Residence 176 Wilshire Dr Sharon MA 02067

Citizenship US

Post Office Address Technology Licensing Office, Massachusetts Institute of Technology,
Five Cambridge Center, Kendall Square, Room NE25-230, Cambridge, MA 02142-1493

Full name of third inventor John B. Heywood

Inventor's signature John B. Heywood Date: 2/7/05

Residence 218 Mill Street, Newton MA 02460

Citizenship USA

Post Office Address Technology Licensing Office, Massachusetts Institute of Technology,
Five Cambridge Center, Kendall Square, Room NE25-230, Cambridge, MA 02142-1493



ATTORNEY DOCKET NO. 0492611-0598

IN THE UNITED STATES PATENT AND TRADEMARK OFFICE

Applicant: Cohn, *et al.* Examiner:
Serial No.: 10/991,774 Art Unit: 1714
Filing Date: November 18, 2004
Title: FUEL MANAGEMENT SYSTEM FOR VARIABLE ETHANOL
OCTANE ENHANCEMENT OF GASOLINE ENGINES

Commissioner For Patents
P. O. Box 1450
Alexandria, VA 22313-1450

APPOINTMENT OF ATTORNEY

The undersigned hereby appoints the attorneys/agents associated with Customer Number 24280 as its attorneys and agents for prosecution of matters relating to the above-identified patent application and to conduct all business in the United States Patent and Trademark Office.

All correspondence should be sent to:

Patent Department
Attn: Sam Pasternack
Choate, Hall & Stewart LLP
Exchange Place, 53 State Street
Boston, Massachusetts 02109

Respectfully submitted,

Name: Karin K. Rivard

Title: Assistant Director/Counsel, Tech. Lic. Office
On behalf of Massachusetts Institute of
Technology

Dated: Dec. 6, 2004



ATTORNEY DOCKET NO. 0492611-0598
IN THE UNITED STATES PATENT AND TRADEMARK OFFICE

Applicant: Cohn, *et al.* Examiner: TBA
Serial No.: 10/991,774 Art Unit: 1714
Filing Date: November 18, 2004
Title: FUEL MANAGEMENT SYSTEM FOR VARIABLE ETHANOL
OCTANE ENHANCEMENT OF GASOLINE ENGINES

Commissioner For Patents
P. O. Box 1450
Alexandria, VA 22313-1450

Sir:

ESTABLISHING RIGHT OF ASSIGNEE TO TAKE ACTION
(37 CFR § 3.73(b))

The inventors of the above-referenced United States patent application have assigned their entire right, title, and interest in the inventions disclosed therein according to the following table:

Inventor	Assignee
Daniel R. Cohn	MASSACHUSETTS INSTITUTE OF TECHNOLOGY
Leslie Bromberg	MASSACHUSETTS INSTITUTE OF TECHNOLOGY
John B. Heywood	MASSACHUSETTS INSTITUTE OF TECHNOLOGY

Thus, the Assignee of the inventors' entire right, title, and interest is:

MASSACHUSETTS INSTITUTE OF TECHNOLOGY

According to 37 CFR § 3.73(b), the Assignee is entitled to take action relating to the application in the Patent and Trademark Office if the Assignee establishes ownership to the satisfaction of the Commissioner.

Ownership by the assignee is established as follows (I authorize Choate, Hall & Stewart to check one of the following two choices, and fill in the blanks, if applicable):

___ documents already recorded in the PTO on _____.

Reel _____ Frame _____; and

___ documents separately submitted for recordal to the PTO (a copy of these documents is attached).

STATEMENT

I, person(s) authorized to sign on behalf of the Assignee, have reviewed the evidentiary documents referred to above and certify that, to the best of my knowledge and belief, title is mine/ours as Assignee who seeks to take further action.

Name/Title	Assignee	Date
Signature: <u><i>Karin K. Rivard</i></u> Name: <u>Karin K. Rivard</u> Title: <u>Assistant Director/Counsel</u>	MASSACHUSETTS INSTITUTE OF TECHNOLOGY Tech. Lic. Office	<u>Dec. 6,</u> <u>2004</u>

UNITED STATES PATENT AND TRADEMARK OFFICE

 COMMISSIONER FOR PATENTS
 UNITED STATES PATENT AND TRADEMARK OFFICE
 WASHINGTON, D.C. 20231
 www.uspto.gov

APPLICATION NUMBER	FILING DATE	FIRST NAMED APPLICANT	ATTORNEY DOCKET NUMBER
10/991,774	11/18/2004	Daniel R. Cohn	0492611-0598

 24280
 CHOATE, HALL & STEWART LLP
 EXCHANGE PLACE
 53 STATE STREET
 BOSTON, MA 02109

CONFIRMATION NO. 8282

OC000000015626244

Date Mailed:

3-31-05

NOTICE OF INFORMAL APPLICATION

This application is considered to be informal since it does not comply with the regulations for the reason(s) indicated below. The period within to correct the informalities noted below and avoid abandonment is set in the accompanying Office action.

Items Required To Avoid Processing Delays:

The item(s) indicated below are also required and should be submitted with any reply to this notice to avoid further processing delays.

A new oath or declaration, identifying this application number is required. The oath or declaration does not comply with 37 CFR 1.63 in that it:

- does not identify the citizenship of each inventor.

*A copy of this notice **MUST** be returned with the reply.*

Office of Initial Patent Examination (703) 308-1202

PART 1 - ATTORNEY/APPLICANT COPY

rfa



IN THE UNITED STATES PATENT AND TRADEMARK OFFICE

Applicant:	Cohn, <i>et al.</i>	:	
Serial No.:	10/991,774	:	Examiner: Not Yet Assigned
Filed:	November 18, 2004	:	Art Unit: 1714
For:	FUEL MANAGEMENT SYSTEM FOR VARIABLE ETHANOL OCTANE ENHANCEMENT OF GASOLINE ENGINES	:	Atty. Docket: 0492611-0598

Certificate of Mailing

I hereby certify that the foregoing document is being deposited with the United States Postal Service, postage prepaid, first class mail, in an envelope addressed to Mail Stop Amendment, Commissioner for Patents, P.O. Box 1450, Alexandria, VA 22313-1450 on this 4th day of April, 2005.

 Name: Cathy A. O'Brien

INFORMATION DISCLOSURE STATEMENT

Mail Stop Amendment
Commissioner for Patents
P.O. Box 1450
Alexandria, VA 22313-1450

Sir:

Submitted herewith on Form PTO-1449 is a listing of documents known to Applicant and/or their attorney in compliance with the requirements of 37 C.F.R. § 1.56. Copies of the documents are also being submitted.

In accordance with 37 C.F.R. 1.97, Applicant does not believe any fees are due in connection with submission of this Information Disclosure Statement since this Information Disclosure Statement is being filed before the mailing date of a first office action on the merits.

The Examiner is respectfully requested to initial the space adjacent to each document on the PTO-1449 form and return a copy of the PTO-1449 form to confirm that these documents have been considered by the Examiner and made of record in this application.

Although we believe that we have appropriately provided for any fees due in connection with this submission, the Commissioner is authorized to credit any overpayment or charge any deficiencies to/from our **Deposit Account No. 03-1721**. A duplicate copy of this form is being submitted.

Should there be any questions after reviewing this paper, the Examiner is invited to contact the undersigned at (617) 248-5143.

Respectfully submitted,
CHOATE, HALL & STEWART LLP

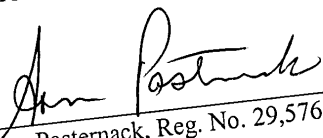
Sam Pasternack, Reg. No. 29,576

Patent Group
CHOATE, HALL & STEWART LLP
Exchange Place
53 State Street
Boston, MA 02109
Tel: (617) 248-5000
Fax: (617) 248-4000

Date: April 4, 2005

Customer Number 24280



Substitute for form 1449A/PTO INFORMATION DISCLOSURE STATEMENT BY APPLICANT (Use as many sheets as necessary)				<i>Complete if Known</i>		
				Application Number	10/991,774	
Sheet		1	of	2	Attorney Docket Number	0492611-0598
				Examiner Name	Not Yet Assigned	
				First Named Inventor	Daniel R. Cohn, et al.	
				Filing Date	November 18, 2004	
				Art Unit	1714	

U.S. PATENT DOCUMENTS					
Examiner Initials*	Cite No. ¹	Document Number	Publication Date MM-DD-YYYY	Name of Patentee or Applicant of Cited Document	Pages, Columns, Lines, Where Relevant Passages or Relevant Figures Appear
		Number-Kind Code ² (if known)			
		US-6,508,233	1/21/2003	Blake R. Suhre, et al.	
		US-6,076,487	6/20/2000	Joseph W. Wulff, et al.	
		US-6,575,147	6/10/2003	Joseph W. Wulff, et al.	
		US-			
		US-			
		US-			
		US-			
		US-			
		US-			
		US-			
		US-			
		US-			

FOREIGN PATENT DOCUMENTS						
Examiner Initials*	Cite No. ¹	Foreign Patent Document	Publication Date MM-DD-YYYY	Name of Patentee or Applicant of Cited Document	Pages, Columns, Lines, Where Relevant Passages or Relevant Figures Appear	T ⁶
		Country Code ³ Number ⁴ Kind Code ⁵ (if known)				
						<input type="checkbox"/>
						<input type="checkbox"/>
						<input type="checkbox"/>
						<input type="checkbox"/>
						<input type="checkbox"/>

Examiner Signature	Date Considered
--------------------	-----------------

*EXAMINER: Initial if reference considered, whether or not citation is in conformance with MPEP 609. Draw line through citation if not in conformance and not considered. Include copy of this form with next communication to applicant. ¹ Applicant's unique citation designation number (optional). ² See Kinds Codes of USPTO Patent Documents at www.uspto.gov or MPEP 901.04. ³ Enter Office that issued the document, by the two-letter code (WIPO Standard ST.3.) ⁴ For Japanese patent documents, the indication of the year of the reign of the Emperor must precede the serial number of the patent document. ⁵ Kind of document by the appropriate symbols as indicated on the document under WIPO Standard ST. 16 if possible. ⁶ Applicant is to place a check mark here if English language Translation is attached.

This collection of information is required by 37 CFR 1.97 and 1.98. The information is required to obtain or retain a benefit by the public which is to file (and by the USPTO to process) an application. Confidentiality is governed by 35 U.S.C. 122 and 37 CFR 1.14. This collection is estimated to take 2 hours to complete, including gathering, preparing, and submitting the completed application form to the USPTO. Time will vary depending upon the individual case. Any comments on the amount of time you require to complete this form and/or suggestions for reducing this burden, should be sent to the Chief Information Officer, U.S. Patent and Trademark Office, U.S. Department of Commerce, P.O. Box 1450, Alexandria, VA 22313-1450. DO NOT SEND FEES OR COMPLETED FORMS TO THIS ADDRESS. SEND TO: Commissioner for Patents, P.O. Box 1450, Alexandria, VA 22313-1450.

If you need assistance in completing the form, call 1-800-PTO-9199 and select option 2.

Substitute for form 1449B/PTO INFORMATION DISCLOSURE STATEMENT BY APPLICANT (Use as many sheets as necessary)			<i>Complete if Known</i>		
			Application Number	10/991,774	
			Filing Date	November 18, 2004	
			First Named Inventor	Daniel R. Cohn, et al.	
			Art Unit	1714	
			Examiner Name	Not Yet Assigned	
Sheet	2	of	2	Attorney Docket Number	0492611-0598

NON-PATENT LITERATURE DOCUMENTS			
Examiner Initials*	Cite No. ¹	Include name of the author (in CAPITAL LETTERS), title of the article (when appropriate), title of the item (book, magazine, journal, serial, symposium, catalog, etc.), date, page(s), volume-issue number(s), publisher, city and/or country where published.	T ²
	A	A. MODAK and L.S. CARETTO, Engine Cooling by Direct Injection of Cooling Water, Society of Automotive Engineers, Inc. 700887	<input type="checkbox"/>
	B	JULIAN A. LoRUSSO and HARRY A. CIKANEK, Direct Injection Ignition Assisted Alcohol Engine, Society of Automotive Engineers, Inc. 880495, International Congress and Exposition in Detroit Michigan (February 29-March 4, 1998)	<input type="checkbox"/>
	C	BÖRJE GRANDIN, HANS-ERIK ÅNGSTRÖM, PER STÅLHAMMAR and ERIC OLOFSSON, Knock Suppression in a Turbocharged SI Engine by Using Cooled EGR, Society of Automotive Engineers, Inc. 982476, International Fall Fuels and Lubricants Meeting and Exposition in San Francisco, California (October 19-22, 1998)	<input type="checkbox"/>
	D	BÖRJE GRANDIN and HANS-ERIK ÅNGSTRÖM, Replacing Fuel Enrichment in a Turbo Charged SI Engine: Lean Burn or Cooled EGR, Society of Automotive Engineers, Inc. 199-01-3505	<input type="checkbox"/>
	E	C. STAN, R. TROEGER, S. GUENTHER, A. STANCIU, L. MARTORANO, C. TARANTINO and R. LENSİ, Internal Mixture Formation and Combustion – from Gasoline to Ethanol, Society of Automotive Engineers, Inc. 2001-01-1207	<input type="checkbox"/>
			<input type="checkbox"/>
			<input type="checkbox"/>
			<input type="checkbox"/>
			<input type="checkbox"/>
			<input type="checkbox"/>

Examiner Signature	Date Considered
--------------------	-----------------

*EXAMINER: Initial if reference considered, whether or not citation is in conformance with MPEP 609. Draw line through citation if not considered. Include copy of this form with next communication to applicant.

¹ Applicant's unique citation designation number (optional). ² Applicant is to place a check mark here if English language Translation is attached.

This collection of information is required by 37 CFR 1.97 and 1.98. The information is required to obtain or retain a benefit by the public which is to file (and by the USPTO to process) an application. Confidentiality is governed by 35 U.S.C. 122 and 37 CFR 1.14. This collection is estimated to take 2 hours to complete, including gathering, preparing, and submitting the completed application form to the USPTO. Time will vary depending upon the individual case. Any comments on the amount of time you require to complete this form and/or suggestions for reducing this burden, should be sent to the Chief Information Officer, U.S. Patent and Trademark Office, U.S. Department of Commerce, P.O. Box 1450, Alexandria, VA 22313-1450. DO NOT SEND FEES OR COMPLETED FORMS TO THIS ADDRESS. SEND TO: Commissioner for Patents, P.O. Box 1450, Alexandria, VA 22313-1450.

If you need assistance in completing the form, call 1-800-PTO-9199 and select option 2.

3833833v1



UNITED STATES PATENT AND TRADEMARK OFFICE

UNITED STATES DEPARTMENT OF COMMERCE
United States Patent and Trademark Office
Address: COMMISSIONER FOR PATENTS
P.O. Box 1450
Alexandria, Virginia 22313-1450
www.uspto.gov

APPLICATION NUMBER	PATENT NUMBER	GROUP ART UNIT	FILE WRAPPER LOCATION
10/991,774		1714	

Correspondence Address / Fee Address Change

The following fields have been set to Customer Number 24280 on 10/06/2005

- Correspondence Address
- Maintenance Fee Address

The address of record for Customer Number 24280 is:

CHOATE, HALL & STEWART LLP
TWO INTERNATIONAL PLACE
BOSTON, MA 02110

**=> IFW: Scan as Doc Code: SRNT <=
Doc Date: 4/10/06**

TC 3700 Inventor Search Program

See attached inventor searches for applications and/or patents to help resolve questions of overlapping subject matter. These searches are provided as an initial examination aid: examiners should perform updated or expanded PALM or EAST inventors searches as appropriate.

Serial Number: 10/991774

**1.) See attached printout of inventors listed in
PALM**

**2.) See attached EAST Inventor Search
Printout shows Inventor search terms**

Day : Monday
Date: 4/10/2006

Time: 14:06:41

PALM INTRANET

Inventor Information for 10/991774

Inventor Name	City	State/Country
COHN, DANIEL R.	CHESTNUT HILL	MASSACHUSETTS
BROMBERG, LESLIE	SHARON	MASSACHUSETTS
HEYWOOD, JOHN B.	NEWTON	MASSACHUSETTS

-

Search Another: Application#
 or Patent#

PCT / /
 or PG PUBS #

Attorney Docket #

Bar Code #

To go back use Back button on your browser toolbar.

Back to [PALM](#) | [ASSIGNMENT](#) | [OASIS](#) | [Home page](#)

US 20060002382 A1	20060105	System and method for establishing calls over dynamic virtual circuit connections in an ATM network	370/356	370/522	Cohn; Daniel M.
US 20050274104 A1	20051215	Optimum regeneration of diesel particulate filters and NOx traps using fuel reformers	60/275	60/286; 60/301	Bromberg, Leslie et al.
US 20050214179 A1	20050929	Low current plasmatron fuel converter having enlarged volume discharges	422/186		Rabinovich, Alexander et al.
US 20050210877 A1	20050929	Wide dynamic range multistage plasmatron reformer system	60/643		Rabinovich, Alexander et al.
US 20050205775 A1	20050922	Plasma ion mobility spectrometer	250/290	250/292; 250/294	Bromberg, Leslie et al.
US 20050165128 A1	20050728	Responsive biomedical composites	523/105	524/555	Cohn, Daniel et al.
US 20050095302 A1	20050505	Novel polymeric compositions exhibiting reverse thermal gellation properties	424/501		Cohn, Daniel et al.
US 20050087436 A1	20050428	Apparatus and method for operating a fuel reformer so as to purge soot therefrom	204/172	431/3	Smaling, Rudolf M. et al.
US 20050069573 A1	20050331	Responsive polymeric system	424/426		Cohn, Daniel et al.
US 20050019230 A1	20050127	Plasmatron-catalyst system	422/186	429/19	Bromberg, Leslie et al.
US 20050008609 A1	20050113	Multi-component reverse thermo-sensitive polymeric systems	424/78.1		Cohn, Daniel et al.
US 20040250790 A1	20041216	High compression ratio, high power density homogeneous charge compression ignition engines using hydrogen and carbon monoxide to enhance auto-ignition	123/300		Heywood, John B. et al.

		resistance			
US 20040202592 A1	20041014	Plasmatron fuel converter having decoupled air flow control	422/186.04	204/168	Rabinovich, Alexander et al.
US 20040156819 A1	N/A, Contact help desk				Cohn, Daniel et al.
US 20040099226 A1	20040527	Homogeneous charge compression ignition control utilizing plasmatron fuel converter technology	123/3		Bromberg, Leslie et al.
US 20040065274 A1	20040408	High compression ratio, hydrogen enhanced engine system	123/1A	123/568.11; 123/585	Cohn, Daniel R. et al.
US 20040035395 A1	20040226	Hydrogen and carbon monoxide enhanced knock resistance in spark ignition gasoline engines	123/435	123/198A	Heywood, John B. et al.
US 20030221949 A1	20031204	Low current plasmatron fuel converter having enlarged volume discharges	204/164	422/186.04	Rabinovich, Alexander et al.
US 20030195162 A1	20031016	Genetic marker for spondyloepimetaphyseal dysplasia	514/44	435/6; 435/91.2; 536/23.2; 536/24.3	Cohn, Daniel H. et al.
US 20030187148 A1	20031002	Novel polymeric compositions exhibiting reverse thermal gellation properties	525/408		Cohn, Daniel et al.
US 20030089337 A1	20030515	High compression ratio, hydrogen enhanced gasoline engine system	123/435	123/1A; 123/568.11	Cohn, Daniel R. et al.
US 20030082235 A1	20030501	Novel reverse thermo-sensitive block copolymers	424/486		Cohn, Daniel et al.
US 20030042231 A1	20030306	Symbiotic solid waste - gaseous waste conversion system for high-efficiency electricity production	219/121.37	110/346; 219/121.48	Surma, Jeffrey E. et al.
US 20020194835	20021226	Emission abatement system utilizing	60/275	60/295; 60/301	Bromberg, Leslie et al.

A1		particulate traps			
US 20020012618 A1	20020131	Plasmatron-catalyst system	422/190	422/191; 422/192; 422/211; 48/117; 48/127.9; 48/61	Bromberg, Leslie et al.
US 20010009662 A1	20010726	Novel polymeric compositions	424/78.17	525/450	Cohn, Daniel et al.
US 6981472 B2	20060103	Homogeneous charge compression ignition control utilizing plasmatron fuel converter technology	123/3	123/27GE; 123/525	Bromberg; Leslie et al.
US 6981055 B1	20051227	Method and system for optimizing routing through multiple available internet route providers	709/238	370/401; 709/239	Ahuja; Abha et al.
US 6881386 B2	20050419	Low current plasmatron fuel converter having enlarged volume discharges	422/186.04	123/3; 422/186.22; 422/186.25; 422/186.28	Rabinovich; Alexander et al.
US 6870012 B2	20050322	Chain-extended peo/ppo/peo block copolymer, optionally with polyester blocks, combined with cellular or bioactive material	525/408	424/174.1; 424/176.1; 424/280.1; 424/94.1; 514/772.7; 525/403	Cohn; Daniel et al.
US 6818428 B1	20041116	3-phosphoadenosine-5-phosphosulfate (PAPS) synthetase proteins and methods for treating osteoarthritic disorders	435/194	424/192.1; 435/252.3; 435/320.1; 536/23.2	Cohn; Daniel H. et al.
US 6793899 B2	20040921	Plasmatron-catalyst system	422/188	422/189; 422/190; 422/198; 422/211; 429/17; 429/19; 48/127.9; 48/DIG.8	Bromberg; Leslie et al.
US 6737604 B2	20040518	Symbiotic solid waste--gaseous waste conversion system for	219/121.37	110/346; 219/121.48	Surma; Jeffrey E. et al.

		high-efficiency electricity production			
US 6718753 B2	20040413	Emission abatement system utilizing particulate traps	60/275		Bromberg; Leslie et al.
US 6696499 B1	20040224	Methods and compositions for reducing or eliminating post-surgical adhesion formation	514/772.1	525/408; 525/424; 525/43; 525/449; 525/454	Cohn; Daniel et al.
US 6655324 B2	20031202	High compression ratio, hydrogen enhanced gasoline engine system	123/1A	123/304; 123/431; 123/568.11; 123/DIG.12	Cohn; Daniel R. et al.
US 6621395 B1	20030916	Methods of charging superconducting materials	335/216	505/879	Bromberg; Leslie
US 6579951 B1	20030617	Chain-extended or crosslinked polyethylene oxide/polypropylene oxide/polyethylene oxide block polymer with optional polyester blocks	525/408	525/403	Cohn; Daniel et al.
US 6560958 B1	20030513	Emission abatement system	60/275	60/286; 60/295; 60/301	Bromberg; Leslie et al.
US 6322757 B1	20011127	Low power compact plasma fuel converter	422/186.04	123/3; 422/186.22; 422/186.28	Cohn; Daniel R. et al.
US 6226516 B1	20010501	Method for invoking dynamically modifiable subscriber services and an intelligent telecommunication network incorporating the same	455/433	379/201.05; 379/207.02; 379/913; 455/414.1	Gupta; Rohit et al.
US 6211249 B1	20010403	Polyester polyether block copolymers	514/772.1	525/408; 525/424; 525/430; 525/449; 525/454	Cohn; Daniel et al.
US 6167064 A	20001226	Method and system in an intelligent communications network for a	370/522	370/410; 455/553.1	Cohn; Daniel et al.

		programmable call control utilizing removable configurable control mechanisms			
US 6160238 A	20001212	Tunable molten oxide pool assisted plasma-melter vitrification systems	219/121.37	110/242; 110/250; 219/121.53; 219/121.54; 219/121.57; 373/22; 373/25; 588/311; 588/314; 588/316; 588/405; 588/406; 588/407; 588/408; 588/409; 588/410; 588/412; 588/413; 588/414; 588/900	Titus; Charles H. et al.
US 6136333 A	20001024	Methods and compositions for reducing or eliminating post-surgical adhesion formation	424/423	424/426; 424/444; 424/486; 424/497; 424/78.17	Cohn; Daniel et al.
US 6127645 A	20001003	Tunable, self-powered arc plasma-melter electro conversion system for waste treatment and resource recovery	219/121.36	110/242; 110/250; 219/121.37; 219/121.53; 219/121.54; 219/121.57; 373/22; 373/25; 588/311; 588/316; 588/405; 588/406; 588/407; 588/408; 588/409; 588/410; 588/412;	Titus; Charles H. et al.

				588/413; 588/414	
US 6081329 A	20000627	Compact trace element sensor which utilizes microwave generated plasma and which is portable by an individual	356/316	333/99PL	Cohn; Daniel R. et al.
US 6066825 A	20000523	Methods and apparatus for low NO.sub.x emissions during the production of electricity from waste treatment systems	219/121.36	110/246; 219/121.37; 219/121.44; 373/18; 588/900	Titus; Charles H. et al.
US 6037560 A	20000314	Enhanced tunable plasma-melter vitrification systems	219/121.37	110/346; 219/121.36; 219/121.52; 219/121.54; 373/18; 588/311; 588/405; 588/406; 588/410	Titus; Charles H. et al.
US 5908564 A	19990601	Tunable, self-powered arc plasma-melter electro conversion system for waste treatment and resource recovery	219/121.36	110/250; 110/346; 219/121.37; 219/121.38; 373/18; 588/900	Titus; Charles H. et al.
US 5887554 A	19990330	Rapid response plasma fuel converter systems	123/3	123/DIG.12	Cohn; Daniel R. et al.
US 5852927 A	19981229	Integrated plasmatron-turbine system for the production and utilization of hydrogen-rich gas	60/780	290/52; 60/39.48	Cohn; Daniel R. et al.
US 5847353 A	19981208	Methods and apparatus for low NO.sub.x emissions during the production of electricity from waste treatment systems	219/121.36	110/246; 219/121.37; 219/121.44; 373/18; 588/900	Titus; Charles H. et al.
US 5825485 A	19981020	Compact trace element sensor which utilizes microwave generated plasma and which is	356/316	333/99PL	Cohn; Daniel R. et al.

		portable by an individual			
US 5798497 A	19980825	Tunable, self-powered integrated arc plasma-melter vitrification system for waste treatment and resource recovery	219/121.37	110/242; 110/250; 219/121.43; 219/121.53; 219/121.54; 219/121.57; 373/22; 373/25	Titus; Charles H. et al.
US 5785426 A	19980728	Self-calibrated active pyrometer for furnace temperature measurements	374/126	374/122; 374/128; 374/130; 374/131; 374/9	Woskov; Paul P. et al.
US 5756957 A	19980526	Tunable molten oxide pool assisted plasma-melter vitrification systems	588/311	110/250; 110/346; 219/121.36; 219/121.57; 219/121.59; 588/314; 588/318; 588/405; 588/406; 588/407; 588/408; 588/409; 588/412; 75/10.1; 75/10.19	Titus; Charles H. et al.
US 5711958 A	19980127	Methods for reducing or eliminating post-surgical adhesion formation	424/423	128/898; 424/424; 424/425; 424/78.06; 514/772.1; 514/772.7	Cohn; Daniel et al.
US 5671045 A	19970923	Microwave plasma monitoring system for the elemental composition analysis of high temperature process streams	356/316	333/99PL	Woskov; Paul P. et al.
US 5666891 A	19970916	ARC plasma-melter electro conversion system for waste treatment and resource recovery	110/250	110/346; 219/121.17; 219/121.38	Titus; Charles H. et al.
US 5573339 A	19961112	Active radiometer for	374/126	374/128;	Woskov; Paul

		self-calibrated furnace temperature measurements		374/131; 374/141	P. et al.
US 5479254 A	19951226	Continuous, real time microwave plasma element sensor	356/316	333/99PL	Woskov; Paul P. et al.
US 5437250 A	19950801	Plasmatron-internal combustion engine system	123/3	123/DIG.12	Rabinovich; Alexander et al.
US 5425332 A	19950620	Plasmatron-internal combustion engine system	123/3	123/DIG.12	Rabinovich; Alexander et al.
US 5409784 A	19950425	Plasmatron-fuel cell system for generating electricity	429/13	180/65.3; 429/21; 429/9	Bromberg; Leslie et al.
US 5256854 A	19931026	Tunable plasma method and apparatus using radio frequency heating and electron beam irradiation	219/121.52	110/242; 110/244; 219/121.21; 219/121.43; 219/121.59; 250/492.21	Bromberg; Leslie et al.
US 5231073 A	19930727	Microwave/far infrared cavities and waveguides using high temperature superconductors	505/475	264/322; 505/410; 505/480; 505/702; 505/704; 505/728; 505/729; 505/740; 505/741	Cohn; Daniel R. et al.
US 5100992 A	19920331	Polyurethane-based polymeric materials and biomedical articles and pharmaceutical compositions utilizing the same	528/26	424/501; 528/28; 528/59; 528/65; 604/19; 604/289; 604/290; 604/327; 604/403; 604/73; 604/8	Cohn; Daniel et al.
US 4968945 A	19901106	Open tube resonator test setup for conductivity measurements	324/633	324/636; 324/653; 324/708	Woskov; Paul P. et al.
US 4918049 A	19900417	Microwave/far infrared cavities and waveguides using high temperature	505/210	315/4; 333/21R; 333/227;	Cohn; Daniel R. et al.

		superconductors		333/238; 333/239; 333/99S; 505/701	
US 4826945 A	19890502	Biodegradable polymeric materials based on polyether glycols, processes for the preparation thereof and surgical articles made therefrom	424/423	424/443; 424/497; 424/78.06; 428/423.7; 428/480; 525/450; 528/76; 604/19	Cohn; Daniel et al.
US 4330761 A	19820518	High power gas laser	372/4	372/59	Cohn; Daniel R. et al.

EAST Search History

Ref #	Hits	Search Query	DBs	Default Operator	Plurals	Time Stamp
L1	194	(anti-knock or antiknock) adj agent\$1 and internal adj combustion adj engine and ethanol	US-PGPUB; USPAT; USOCR; EPO; JPO; DERWENT; IBM_TDB	OR	OFF	2006/04/18 08:31



UNITED STATES PATENT AND TRADEMARK OFFICE

UNITED STATES DEPARTMENT OF COMMERCE
United States Patent and Trademark Office
Address: COMMISSIONER FOR PATENTS
P.O. Box 1450
Alexandria, Virginia 22313-1450
www.uspto.gov

APPLICATION NO.	FILING DATE	FIRST NAMED INVENTOR	ATTORNEY DOCKET NO.	CONFIRMATION NO.
10/991,774	11/18/2004	Daniel R. Cohn	0492611-0598	8282
24280	7590	04/25/2006	EXAMINER	
CHOATE, HALL & STEWART LLP			ALI, HYDER	
TWO INTERNATIONAL PLACE			ART UNIT	
BOSTON, MA 02110			PAPER NUMBER	
			3747	

DATE MAILED: 04/25/2006

Please find below and/or attached an Office communication concerning this application or proceeding.

Office Action Summary	Application No.	Applicant(s)	
	10/991,774	COHN ET AL.	
	Examiner	Art Unit	
	HYDER ALI	3747	

-- The MAILING DATE of this communication appears on the cover sheet with the correspondence address --
Period for Reply

A SHORTENED STATUTORY PERIOD FOR REPLY IS SET TO EXPIRE 3 MONTH(S) OR THIRTY (30) DAYS, WHICHEVER IS LONGER, FROM THE MAILING DATE OF THIS COMMUNICATION.

- Extensions of time may be available under the provisions of 37 CFR 1.136(a). In no event, however, may a reply be timely filed after SIX (6) MONTHS from the mailing date of this communication.
- If NO period for reply is specified above, the maximum statutory period will apply and will expire SIX (6) MONTHS from the mailing date of this communication.
- Failure to reply within the set or extended period for reply will, by statute, cause the application to become ABANDONED (35 U.S.C. § 133). Any reply received by the Office later than three months after the mailing date of this communication, even if timely filed, may reduce any earned patent term adjustment. See 37 CFR 1.704(b).

Status

- 1) Responsive to communication(s) filed on ____.
- 2a) This action is **FINAL**. 2b) This action is non-final.
- 3) Since this application is in condition for allowance except for formal matters, prosecution as to the merits is closed in accordance with the practice under *Ex parte Quayle*, 1935 C.D. 11, 453 O.G. 213.

Disposition of Claims

- 4) Claim(s) 1-20 and 24-56 is/are pending in the application.
 4a) Of the above claim(s) _____ is/are withdrawn from consideration.
- 5) Claim(s) _____ is/are allowed.
- 6) Claim(s) 1-20 and 24-56 is/are rejected.
- 7) Claim(s) _____ is/are objected to.
- 8) Claim(s) _____ are subject to restriction and/or election requirement.

Application Papers

- 9) The specification is objected to by the Examiner.
- 10) The drawing(s) filed on 18 November 2004 is/are: a) accepted or b) objected to by the Examiner.
 Applicant may not request that any objection to the drawing(s) be held in abeyance. See 37 CFR 1.85(a).
 Replacement drawing sheet(s) including the correction is required if the drawing(s) is objected to. See 37 CFR 1.121(d).
- 11) The oath or declaration is objected to by the Examiner. Note the attached Office Action or form PTO-152.

Priority under 35 U.S.C. § 119

- 12) Acknowledgment is made of a claim for foreign priority under 35 U.S.C. § 119(a)-(d) or (f).
 a) All b) Some * c) None of:
1. Certified copies of the priority documents have been received.
 2. Certified copies of the priority documents have been received in Application No. _____.
 3. Copies of the certified copies of the priority documents have been received in this National Stage application from the International Bureau (PCT Rule 17.2(a)).

* See the attached detailed Office action for a list of the certified copies not received.

Attachment(s)

- | | |
|---|---|
| 1) <input checked="" type="checkbox"/> Notice of References Cited (PTO-892) | 4) <input type="checkbox"/> Interview Summary (PTO-413)
Paper No(s)/Mail Date. _____ |
| 2) <input type="checkbox"/> Notice of Draftsperson's Patent Drawing Review (PTO-948) | 5) <input type="checkbox"/> Notice of Informal Patent Application (PTO-152) |
| 3) <input checked="" type="checkbox"/> Information Disclosure Statement(s) (PTO-1449 or PTO/SB/08)
Paper No(s)/Mail Date <u>4/6/05</u> . | 6) <input type="checkbox"/> Other: _____ |

DETAILED ACTION

Inventorship

This application currently names joint inventors. In considering patentability of the claims under 35 U.S.C. 103(a), the examiner presumes that the subject matter of the various claims was commonly owned at the time any inventions covered therein were made absent any evidence to the contrary. Applicant is advised of the obligation under 37 CFR 1.56 to point out the inventor and invention dates of each claim that was not commonly owned at the time a later invention was made in order for the examiner to consider the applicability of 35 U.S.C. 103(c) and potential 35 U.S.C. 102(e), (f) or (g) prior art under 35 U.S.C. 103(a).

Claim Objections

Claims 11 and 44 are objected to because of the following informalities: the limitation "substantial organized motion such as swirl" should read "substantial organized swirl motion". Appropriate correction is required.

Claim Rejections - 35 USC § 103

The following is a quotation of 35 U.S.C. 103(a) which forms the basis for all obviousness rejections set forth in this Office action:

(a) A patent may not be obtained though the invention is not identically disclosed or described as set forth in section 102 of this title, if the differences between the subject matter sought to be patented and the prior art are such that the subject matter as a whole would have been obvious at the time the invention was made to a person having ordinary skill in the art to which said subject matter pertains. Patentability shall not be negated by the manner in which the invention was made.

1. Claims 1-20,24-29 are rejected under 35 U.S.C. 103(a) as being unpatentable over Takeda (US 4,480,616) in view of Cantwell et al (US 3,106,194).

Takeda discloses fuel management system for operation of a spark ignition gasoline engine comprising: a gasoline engine ; a source of an anti-knock agent 18; an injector 16 for injection of the anti-knock agent into the engine; and a fuel management control system 24 for controlling injection of the anti-knock agent into the engine to control knock.

Takeda does not disclose direct injection of the anti-knock agent into a cylinder of the engine.

Cantwell et al discloses direct injection of the anti-knock agent into a cylinder 18 of the engine 20.

It would have been obvious to one of ordinary skill in the art at the time of the invention was made to modify the invention of Takeda by employing direct injection of the anti-knock agent into a cylinder 18 of the engine 20 as taught by Cantwell in order to provide Takeda engine capable of direct injection of the anti-knock agent into a cylinder of the engine.

With regard to claim 2, Cantwell et al discloses wherein the injectors 16 deposit the anti-knock agent to provide non-uniform deposition within a cylinder 18.

With regard to claim 3, Cantwell et al discloses wherein the anti-knock agent is deposited near the walls of the cylinder 18.

With regard to claim 4, Cantwell et al discloses wherein the non-uniform deposition is obtained through direct injection and charge swirl.

With regard to claim 5, Takeda discloses anti-knock agent is alcohol.

With regard to claim 6, Takeda discloses wherein the fuel management system 24 includes a microprocessor that operates in an open loop fashion on a predetermined correlation between required octane number enhancement and fraction of fuel provided by the anti-knock agent.

With regard to claim 7, wherein the gasoline engine includes a knock sensors providing a feedback signal to a fuel management microprocessor to minimize the amount of the anti-knock agent added to prevent knock in a closed loop fashion (optional design choice).

With regard to claim 8, Takeda discloses anti-knock agent is alcohol such as ethanol.

With regard to claim 9, Takeda discloses alcohol such as ethanol is mixed with water.

With regard to claim 10, wherein the ethanol is mixed with a lubricant (optional design choice).

With regard to claim 11, Takeda discloses engine has substantial organized swirl motion.

With regard to claim 12, Takeda discloses wherein the system includes a measure of the amount of anti-knock agent in the source to control turbocharging, supercharging or spark retard when the amount of anti-knock agent is low.

With regard to claim 13, Takeda discloses wherein the anti-knock agent is added only during portions of a drive cycle requiring knock resistance.

With regard to claim 14, Cantwell et al discloses wherein gasoline is port injected into the engine.

Art Unit: 3747

With regard to claim 15, Cantwell et al discloses wherein the gasoline is directly injected into the cylinder.

With regard to claim 16, wherein the direct injection of ethanol provides substantially a 13 degrees Celsius drop in temperature for every 10% of fuel energy provided by the ethanol (optional design choice).

With regard to claim 17, Takeda discloses wherein the fuel management system substantially minimizes the amount of anti-knock agent used over a drive cycle.

With regard to claim 18, wherein an octane enhancement of at least 4 octane numbers is obtained when 20% of the fuel energy in a cylinder comes from ethanol (optional design choice).

With regard to claim 19, wherein turbocharging or supercharging are reduced or eliminated and/or spark retard is increased when the anti-knock agent is not available (optional design choice).

With regard to claim 20, Takeda discloses wherein alcohol (ethanol) is injected proximate to a cylinder wall and swirl creates a ring of alcohol (ethanol).

With regard to claim 24, Takeda discloses wherein the engine is operated with substantially a stoichiometric air/fuel ratio.

With regard to claim 25, Takeda discloses wherein the alcohol such as ethanol is added only during portions of the drive cycle requiring knock resistance and its use is minimized during those times.

With regard to claim 26, Takeda discloses wherein the ethanol is separated from a gasoline/alcohol (ethanol) mixture.

With regard to claim 27, wherein torque of the engine at which knock occurs can be increased by at least a factor of two by the direct injection of ethanol.

With regard to claim 28, wherein horsepower of a given size engine can be at least doubled by using alcohol (ethanol) octane enhancement.

With regard to claim 29, wherein gasoline consumption is reduced by at least 20% due to higher efficiency engine operation.

2. Claims 30-56 are rejected under 35 U.S.C. 103(a) as being unpatentable over Takeda (US 4,480,616) in view of Krauja et al (US 4,721,081).

Takeda discloses fuel management system for operation of a spark ignition gasoline engine comprising: a gasoline engine; a source of alcohol (may be ethanol); an injector for injection of the alcohol (may be ethanol) into the engine; and a fuel management control system 24 for controlling injection of the alcohol (may be ethanol) into the cylinder when engine torque is above a selected fraction of maximum torque.

Takeda does not disclose an injector for direct injection of the ethanol into a cylinder of the engine.

Krauja et al discloses an injector 22 for direct injection of the ethanol into a cylinder of the engine 14.

It would have been obvious to one of ordinary skill in the art at the time of the invention was made to modify the invention of Takeda by employing direct injection of the ethanol into a cylinder of the engine 14 as taught by Krauja et al in order to provide Takeda engine capable of direct injection of the alcohol (ethanol) into a cylinder of the engine.

With regard to claim 31, wherein torque levels at which the alcohol (ethanol) is directly injected are those where knock would occur absent the ethanol injection.

With regard to claim 32, wherein the fraction of total fuel provided by the directly injected ethanol increases with increasing torque.

With regard to claim 33, Takeda discloses wherein gasoline is port fuel injected.

With regard to claim 34, Krauja et al discloses wherein up to and including substantially 100% of the fuel can be provided by the ethanol.

With regard to claim 35, wherein octane number is enhanced with increasing torque.

With regard to claim 36, wherein an octane enhancement of more than 20 octane numbers is achieved (optional design choice).

With regard to claim 37, Takeda discloses wherein the fuel management system 24 includes a microprocessor that operates in an open loop fashion on a predetermined correlation between required octane number enhancement and fraction of fuel provided by the alcohol (ethanol).

With regard to claim 38, wherein the gasoline engine includes a knock sensors providing a feedback signal to a fuel management microprocessor to minimize the amount of the anti-knock agent added to prevent knock in a closed loop fashion (optional design choice).

With regard to claim 39, Krauja et al discloses wherein the injectors 22 provide non-uniform deposition of the ethanol within a cylinder.

With regard to claim 40, Krauja et al discloses wherein the ethanol is deposited near the walls of the cylinder.

Art Unit: 3747

With regard to claim 41, Krauja et al discloses wherein the non-uniform deposition is obtained through direct injection and charge swirl.

With regard to claim 42, wherein alcohol (ethanol) mixed with water.

With regard to claim 43, wherein the ethanol is mixed with a lubricant (optional design choice).

With regard to claim 44, Takeda discloses engine has substantial organized swirl motion.

With regard to claim 45, Takeda discloses wherein the system includes a measure of the amount of anti-knock agent in the source to control turbocharging, supercharging or spark retard when the amount of alcohol (ethanol) is low.

With regard to claim 46, wherein the gasoline is directly injected into the cylinder (optional design choice).

With regard to claim 47, wherein the direct injection of ethanol provides substantially a 13 degrees Celsius drop in temperature for every 10% of fuel energy provided by the ethanol (optional design choice).

With regard to claim 48, Takeda discloses wherein the fuel management system substantially minimizes the amount of alcohol (ethanol) used over a drive cycle.

With regard to claim 49, wherein an octane enhancement of at least 4 octane numbers is obtained when 20% of the fuel energy in a cylinder comes from ethanol (optional design choice).

With regard to claim 50, wherein turbocharging or supercharging are reduced or eliminated and/or spark retard is increased when the anti-knock agent is not available (optional design choice).

Art Unit: 3747

With regard to claim 51, Takeda discloses wherein the engine is operated with substantially a stoichiometric air/fuel ratio.

With regard to claim 52, Takeda discloses wherein the ethanol is separated from a gasoline/alcohol (ethanol) mixture.

With regard to claim 53, wherein the engine can be operated with only gasoline and knock can be avoided by reducing the maximum torque and horsepower relative to values when alcohol (ethanol) is directly injected into the cylinder.

With regard to claim 54, wherein the horsepower is reduced by at least a factor of two.

With regard to claim 55, wherein the fuel management microprocessor control system uses alcohol (ethanol) level in the ethanol tank as an input to control a turbocharger, supercharger or spark retard.

With regard to claim 56, wherein the turbocharger, supercharger or spark retard is adjusted to prevent knock.

Conclusion

Any inquiry concerning this communication or earlier communications from the examiner should be directed to HYDER ALI whose telephone number is (571) 272-4836. The examiner can normally be reached on M-F (8:30-5:00). The fax phone number for the organization where this application or proceeding is assigned is 571-273-8300. Information regarding the status of an application may be obtained from the Patent Application Information Retrieval (PAIR) system. Status information for published applications may be obtained from either Private PAIR or Public PAIR. Status information for unpublished applications is available through Private PAIR only. For more information about the PAIR system, see <http://pair-direct.uspto.gov>. Should you have questions on access to the Private PAIR system, contact the Electronic Business Center (EBC) at 866-217-9197 (toll-free).

Hyder Ali
ha

Stephen K. Cronin
Primary Examiner
SPE 3747



Substitute for form 1449A/PTO INFORMATION DISCLOSURE STATEMENT BY APPLICANT (Use as many sheets as necessary)			<i>Complete if Known</i>		
			Application Number	10/991,774	
			Filing Date	November 18, 2004	
			First Named Inventor	Daniel R. Cohn, et al.	
			Art Unit	1714	
			Examiner Name	Not Yet Assigned	
Sheet	1	of	2	Attorney Docket Number	0492611-0598

U.S. PATENT DOCUMENTS					
Examiner Initials*	Cite No. ¹	Document Number	Publication Date MM-DD-YYYY	Name of Patentee or Applicant of Cited Document	Pages, Columns, Lines, Where Relevant Passages or Relevant Figures Appear
		Number-Kind Code ² (if known)			
HA		US-6,508,233	1/21/2003	Blake R. Suhre, et al.	_____
HA		US-6,076,487	6/20/2000	Joseph W. Wulff, et al.	_____
HA		US-6,575,147	6/10/2003	Joseph W. Wulff, et al.	_____
		US-			
		US-			
		US-			
		US-			
		US-			
		US-			
		US-			
		US-			

FOREIGN PATENT DOCUMENTS						
Examiner Initials*	Cite No. ¹	Foreign Patent Document	Publication Date MM-DD-YYYY	Name of Patentee or Applicant of Cited Document	Pages, Columns, Lines, Where Relevant Passages or Relevant Figures Appear	T ⁶
		Country Code ² -Number ³ -Kind Code ⁴ (if known)				
						<input type="checkbox"/>
						<input type="checkbox"/>
						<input type="checkbox"/>
						<input type="checkbox"/>
						<input type="checkbox"/>

Examiner Signature	<i>Hyden AG</i>	Date Considered	4/17/06
--------------------	-----------------	-----------------	---------

*EXAMINER: Initial if reference considered, whether or not citation is in conformance with MPEP 609. Draw line through citation if not in conformance and not considered. Include copy of this form with next communication to applicant. ¹ Applicant's unique citation designation number (optional). ² See Kinds Codes of USPTO Patent Documents at www.uspto.gov or MPEP 901.04. ³ Enter Office that issued the document, by the two-letter code (WIPO Standard ST.3.) ⁴ For Japanese patent documents, the indication of the year of the reign of the Emperor must precede the serial number of the patent document. ⁵ Kind of document by the appropriate symbols as indicated on the document under WIPO Standard ST. 16 if possible. ⁶ Applicant is to place a check mark here if English language Translation is attached.

This collection of information is required by 37 CFR 1.97 and 1.98. The information is required to obtain or retain a benefit by the public which is to file (and by the USPTO to process) an application. Confidentiality is governed by 35 U.S.C. 122 and 37 CFR 1.14. This collection is estimated to take 2 hours to complete, including gathering, preparing, and submitting the completed application form to the USPTO. Time will vary depending upon the individual case. Any comments on the amount of time you require to complete this form and/or suggestions for reducing this burden, should be sent to the Chief Information Officer, U.S. Patent and Trademark Office, U.S. Department of Commerce, P.O. Box 1450, Alexandria, VA 22313-1450. DO NOT SEND FEES OR COMPLETED FORMS TO THIS ADDRESS. SEND TO: Commissioner for Patents, P.O. Box 1450, Alexandria, VA 22313-1450.

If you need assistance in completing the form, call 1-800-PTO-9199 and select option 2.

Substitute for form 1449B/PTO INFORMATION DISCLOSURE STATEMENT BY APPLICANT (Use as many sheets as necessary)			<i>Complete if Known</i>		
			Application Number	10/991,774	
			Filing Date	November 18, 2004	
			First Named Inventor	Daniel R. Cohn, et al.	
			Art Unit	1714	
			Examiner Name	Not Yet Assigned	
Sheet	2	of	2	Attorney Docket Number	0492611-0598

NON-PATENT LITERATURE DOCUMENTS			
Examiner Initials*	Cite No. ¹	Include name of the author (in CAPITAL LETTERS), title of the article (when appropriate), title of the item (book, magazine, journal, serial, symposium, catalog, etc.), date, page(s), volume-issue number(s), publisher, city and/or country where published.	T ²
HA	A	A. MODAK and L.S. CARETTO, Engine Cooling by Direct Injection of Cooling Water, Society of Automotive Engineers, Inc. 700887	<input checked="" type="checkbox"/>
HA	B	JULIAN A. LoRUSSO and HARRY A. CIKANEK, Direct Injection Ignition Assisted Alcohol Engine, Society of Automotive Engineers, Inc. 880495, International Congress and Exposition in Detroit Michigan (February 29-March 4, 1998)	<input checked="" type="checkbox"/>
HA	C	BÖRJE GRANDIN, HANS-ERIK ÅNGSTRÖM, PER STÅLHAMMAR and ERIC OLOFSSON, Knock Suppression in a Turbocharged SI Engine by Using Cooled EGR, Society of Automotive Engineers, Inc. 982476, International Fall Fuels and Lubricants Meeting and Exposition in San Francisco, California (October 19-22, 1998)	<input checked="" type="checkbox"/>
HA	D	BÖRJE GRANDIN and HANS-ERIK ÅNGSTRÖM, Replacing Fuel Enrichment in a Turbo Charged SI Engine: Lean Burn or Cooled EGR, Society of Automotive Engineers, Inc. 199-01-3505	<input checked="" type="checkbox"/>
HA	E	C. STAN, R. TROEGER, S. GUENTHER, A. STANCIU, L. MARTORANO, C. TARANTINO and R. LENSI, Internal Mixture Formation and Combustion - from Gasoline to Ethanol, Society of Automotive Engineers, Inc. 2001-01-1207	<input checked="" type="checkbox"/>
			<input type="checkbox"/>
			<input type="checkbox"/>
			<input type="checkbox"/>
			<input type="checkbox"/>
			<input type="checkbox"/>

Examiner Signature	Hyder Ali	Date Considered	4/17/06
--------------------	-----------	-----------------	---------

*EXAMINER: Initial if reference considered, whether or not citation is in conformance with MPEP 609. Draw line through citation if not considered. Include copy of this form with next communication to applicant.

¹ Applicant's unique citation designation number (optional). ² Applicant is to place a check mark here if English language Translation is attached.

This collection of information is required by 37 CFR 1.97 and 1.98. The information is required to obtain or retain a benefit by the public which is to file (and by the USPTO to process) an application. Confidentiality is governed by 35 U.S.C. 122 and 37 CFR 1.14. This collection is estimated to take 2 hours to complete, including gathering, preparing, and submitting the completed application form to the USPTO. Time will vary depending upon the individual case. Any comments on the amount of time you require to complete this form and/or suggestions for reducing this burden, should be sent to the Chief Information Officer, U.S. Patent and Trademark Office, U.S. Department of Commerce, P.O. Box 1450, Alexandria, VA 22313-1450. DO NOT SEND FEES OR COMPLETED FORMS TO THIS ADDRESS. SEND TO: Commissioner for Patents, P.O. Box 1450, Alexandria, VA 22313-1450.

If you need assistance in completing the form, call 1-800-PTO-9199 and select option 2.

3833833v1

Notice of References Cited	Application/Control No. 10/991,774	Applicant(s)/Patent Under Reexamination COHN ET AL.	
	Examiner HYDER ALI	Art Unit 3747	Page 1 of 1

U.S. PATENT DOCUMENTS

*	Document Number Country Code-Number-Kind Code	Date MM-YYYY	Name	Classification
*	A US-4,480,616	11-1984	Takeda, Keiso	123/406.52
*	B US-3,106,194	10-1963	CANTWELL JR EDWARD N; et. al.	123/1A
*	C US-4,721,081	01-1988	Krauja et al.	123/298
	D US-			
	E US-			
	F US-			
	G US-			
	H US-			
	I US-			
	J US-			
	K US-			
	L US-			
	M US-			

FOREIGN PATENT DOCUMENTS

*	Document Number Country Code-Number-Kind Code	Date MM-YYYY	Country	Name	Classification
	N				
	O				
	P				
	Q				
	R				
	S				
	T				

NON-PATENT DOCUMENTS

*	Document Number Country Code-Number-Kind Code	Date MM-YYYY	Country	Name	Classification
	Include as applicable: Author, Title Date, Publisher, Edition or Volume, Pertinent Pages)				
	U				
	V				
	W				
	X				

*A copy of this reference is not being furnished with this Office action. (See MPEP § 707.05(a).)
Dates in MM-YYYY format are publication dates. Classifications may be US or foreign.



UNITED STATES PATENT AND TRADEMARK OFFICE

UNITED STATES DEPARTMENT OF COMMERCE
 United States Patent and Trademark Office
 Address: COMMISSIONER FOR PATENTS
 P.O. Box 1450
 Alexandria, Virginia 22313-1450
 www.uspto.gov



Bib Data Sheet

CONFIRMATION NO. 8282

SERIAL NUMBER 10/991,774	FILING DATE 11/18/2004 RULE	CLASS 123	GROUP ART UNIT 3747	ATTORNEY DOCKET NO. 0492611-0598	
APPLICANTS Daniel R. Cohn, Chestnut Hill, MA; Leslie Bromberg, Sharon, MA; John B. Heywood, Newton, MA; ** CONTINUING DATA ***** NONE ** FOREIGN APPLICATIONS ***** NONE IF REQUIRED, FOREIGN FILING LICENSE GRANTED ** SMALL ENTITY ** ** 03/01/2005					
Foreign Priority claimed <input type="checkbox"/> yes <input checked="" type="checkbox"/> no	35 USC 119 (a-d) conditions met <input checked="" type="checkbox"/> yes <input type="checkbox"/> no	STATE OR COUNTRY MA	SHEETS DRAWING 3	TOTAL CLAIMS 56	INDEPENDENT CLAIMS 2
Verified and Acknowledged Examiner's Signature: <i>H. S. A.</i>	Met after Allowance Initials: <i>HA</i>				
ADDRESS 24280 CHOATE, HALL & STEWART LLP TWO INTERNATIONAL PLACE BOSTON, MA 02110					
TITLE Fuel management system for variable ethanol octane enhancement of gasoline engines					
FILING FEE RECEIVED 1312	FEES: Authority has been given in Paper No. _____ to charge/credit DEPOSIT ACCOUNT No. _____ for following:		<input type="checkbox"/> All Fees <input type="checkbox"/> 1.16 Fees (Filing) <input type="checkbox"/> 1.17 Fees (Processing Ext. of time) <input type="checkbox"/> 1.18 Fees (Issue) <input type="checkbox"/> Other _____ <input type="checkbox"/> Credit		

Index of Claims



Application/Control No.

10/991,774

Examiner

HYDER ALI

Applicant(s)/Patent under Reexamination

COHN ET AL.

Art Unit

3747

√	Rejected
=	Allowed

-	(Through numeral) Cancelled
+	Restricted

N	Non-Elected
I	Interference

A	Appeal
O	Objected

Claim		Date						
Final	Original							
		4/18/06						
1	✓							
2								
3								
4								
5								
6								
7								
8								
9								
10								
11								
12								
13								
14								
15								
16								
17								
18								
19								
20	✓							
21								
22								
23								
24	✓							
25								
26								
27								
28								
29								
30								
31								
32								
33								
34								
35								
36								
37								
38								
39								
40								
41								
42								
43								
44								
45								
46								
47								
48								
49	✓							
50	✓							

Claim		Date						
Final	Original							
		4/18/06						
51	✓							
52								
53								
54								
55								
56	✓							
57								
58								
59								
60								
61								
62								
63								
64								
65								
66								
67								
68								
69								
70								
71								
72								
73								
74								
75								
76								
77								
78								
79								
80								
81								
82								
83								
84								
85								
86								
87								
88								
89								
90								
91								
92								
93								
94								
95								
96								
97								
98								
99								
100								

Claim		Date						
Final	Original							
101								
102								
103								
104								
105								
106								
107								
108								
109								
110								
111								
112								
113								
114								
115								
116								
117								
118								
119								
120								
121								
122								
123								
124								
125								
126								
127								
128								
129								
130								
131								
132								
133								
134								
135								
136								
137								
138								
139								
140								
141								
142								
143								
144								
145								
146	/							
147								
148								
149								
150								

Search Notes



Application/Control No.

10/991,774

Examiner

HYDER ALI

Applicant(s)/Patent under Reexamination

COHN ET AL.

Art Unit

3747

SEARCHED

Class	Subclass	Date	Examiner
123	1A	4/17/2006	HA
123	198A	4/17/2006	HA
123	525	4/17/2006	HA
123	25A	4/17/2006	HA
123	25J	4/17/2006	HA

INTERFERENCE SEARCHED

Class	Subclass	Date	Examiner

**SEARCH NOTES
(INCLUDING SEARCH STRATEGY)**

	DATE	EXMR
SEARCHED EAST SEE EAST SEARCH PRINT OUT.	4/17/2006	HA



IN THE UNITED STATES PATENT AND TRADEMARK OFFICE

Applicant:	Cohn, et al.	:	
Serial No.:	10/991,774	:	Examiner: Ali, Hyder
Filed:	November 18, 2004	:	Art Unit: 3747
For:	FUEL MANAGEMENT SYSTEM FOR VARIABLE ETHANOL OCTANE ENHANCEMENT OF GASOLINE ENGINES	:	Atty. Docket: 0492611-0598

CERTIFICATE OF MAILING

I hereby certify that the foregoing document is being deposited with the United States Postal Service, postage prepaid, in an envelope addressed to Mail Stop Amendment, Commissioner for Patents, P.O. Box 1450, Alexandria, VA 22313-1450 on July 6, 2006.

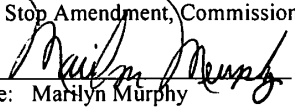
Name: Marilyn Murphy

AMENDMENT AND RESPONSE TO OFFICE ACTION

Mail Stop Amendment
Commissioner for Patents
P.O. Box 1450
Alexandria, VA 22313-1450

Sir:

In response to the Office Action mailed April 25, 2006, please amend the application as follows:

Amendments to the Claims are reflected in the listing of claims which begin on page 2 of this paper.

Remarks begin on page 7 of this paper.

It is not believed that extensions of time or fees for net addition of claims are required, beyond those which may otherwise be provided for in documents accompanying this paper. However, in the event that additional extensions of time are necessary, then such extensions of time are hereby petitioned under 37 C.F.R. § 1.136(a), and any fees required for consideration of this paper (including fees for net addition of claims) are authorized to be charged in the Amendment Transmittal Letter filed herewith.

4099747v1

AMENDMENTS TO THE CLAIMS:

This listing of claims will replace all prior versions and listing of claims in the above-referenced application.

Listing of Claims:

1. (currently amended) Fuel management system for operation of a spark ignition gasoline engine comprising:
 - a gasoline engine;
 - a source of ~~an~~ a liquid fuel anti-knock agent;
 - an injector for direct injection of the liquid fuel anti-knock agent into a cylinder of the engine for vaporization in the cylinder to provide charge cooling; and
 - a fuel management control system including a microprocessor for controlling injection of the liquid fuel anti-knock agent into the cylinder to control knock wherein the fuel management control system microprocessor substantially minimizes the amount of anti-knock agent used over a drive cycle.
2. (previously presented) The system of claim 1 wherein the injectors deposit the anti-knock agent to provide non-uniform deposition within a cylinder.
3. (original) The system of claim 2 wherein the anti-knock agent is deposited near the walls of the cylinder.
4. (previously presented) The system of claim 2 wherein the non-uniform deposition is obtained through direct injection and charge swirl.
5. (original) The system of claim 1 wherein the anti-knock agent is selected from the group consisting of ethanol, methanol, tertiary butyl alcohol, MTBE, ETBE and TAME.
6. (previously presented) The system of claim 1 wherein the fuel management system includes a microprocessor that operates in an open loop fashion on a predetermined correlation between required octane number enhancement and fraction of fuel provided by the anti-knock agent.

7. (original) The system of claim 1 wherein the gasoline engine includes a knock sensor providing a feedback signal to a fuel management microprocessor to minimize the amount of the anti-knock agent added to prevent knock in a closed loop fashion.
8. (original) The system of claim 1 wherein the anti-knock agent is ethanol.
9. (original) The system of claim 8 wherein the ethanol is mixed with water.
10. (original) The system of claim 8 wherein the ethanol is mixed with a lubricant.
11. (original) The system of claim 1 wherein the engine has substantial organized motion such as swirl.
12. (original) The system of claim 1 wherein the system includes a measure of the amount of anti-knock agent in the source to control turbocharging, supercharging or spark retard when the amount of anti-knock agent is low.
13. (original) The system of claim 1 wherein the anti-knock agent is added only during portions of a drive cycle requiring knock resistance.
14. (original) The system of claim 1 wherein gasoline is port injected into the engine.
15. (original) The system of claim 1 wherein the gasoline is directly injected into the cylinder.
16. (original) The system of claim 8 wherein the direct injection of ethanol provides substantially a 13°C drop in temperature for every 10% of fuel energy provided by the ethanol.
17. (canceled)
18. (original) The system of claim 8 wherein an octane enhancement of at least 4 octane numbers is obtained when 20% of the fuel energy in a cylinder comes from ethanol.
19. (original) The system of claim 1 wherein turbocharging or supercharging are reduced or eliminated and/or spark retard is increased when the anti-knock agent is not available.

20. (original) The system of claim 8 wherein ethanol is injected proximate to a cylinder wall and swirl creates a ring of ethanol.

21-23. (cancelled)

24. (previously presented) The system of claim 8 wherein the engine is operated with substantially a stoichiometric air/fuel ratio.

25. (previously presented) The system of claim 8 wherein the ethanol is added only during portions of the drive cycle requiring knock resistance and its use is minimized during those times.

26. (previously presented) The system of claim 8 wherein the ethanol is separated from a gasoline/ethanol mixture.

27. (previously presented) The system of claim 8 wherein torque of the engine at which knock occurs can be increased by at least a factor of two by the direct injection of ethanol.

28. (previously presented) The system of claim 8 wherein horsepower of a given size engine can be at least doubled by using ethanol octane enhancement.

29. (previously presented) The system of claim 8 wherein gasoline consumption is reduced by at least 20% due to higher efficiency engine operation.

30. (currently amended) Fuel management system for operation of a spark ignition gasoline engine comprising:

a gasoline engine;

a source of liquid ethanol;

an injector for direct injection of the liquid ethanol into a cylinder of the engine for vaporization in the cylinder to provide charge cooling; and

a fuel management control system for controlling injection of the liquid ethanol into the cylinder when engine torque is above a selected fraction of maximum torque to control knock.

31. (previously presented) The system of claim 30 wherein torque levels at which the ethanol is directly injected are those where knock would occur absent the ethanol injection.

32. (previously presented) The system of claim 30 wherein the fraction of total fuel provided by the directly injected ethanol increases with increasing torque.
33. (previously presented) The system of claim 30 wherein gasoline is port fuel injected.
34. (previously presented) The system of claim 30 wherein up to and including substantially 100% of the fuel can be provided by the ethanol.
35. (previously presented) The system of claim 30 wherein octane number is enhanced with increasing torque.
36. (previously presented) The system of claim 30 wherein an octane enhancement of more than 20 octane numbers is achieved.
37. (previously presented) The system of claim 30 wherein the fuel management system includes a microprocessor that operates in an open loop fashion on a predetermined correlation between the required octane number enhancement and fraction of fuel provided by the ethanol.
38. (previously presented) The system of claim 30 wherein the gasoline engine includes a knock sensor providing a feedback signal to a fuel management microprocessor to minimize the amount of the ethanol added to prevent knock in a closed loop fashion.
39. (previously presented) The system of claim 30 wherein the injector provides non-uniform deposition of the ethanol within a cylinder.
40. (previously presented) The system of claim 39 wherein the ethanol is deposited near the walls of the cylinder.
41. (previously presented) The system of claim 39 wherein the non-uniform deposition is obtained through direct injection and charge swirl.
42. (previously presented) The system of claim 30 wherein the ethanol is mixed with water.
43. (previously presented) The system of claim 30 wherein the ethanol is mixed with a lubricant.
44. (previously presented) The system of claim 30 wherein the engine has substantial organized motion such as swirl.
45. (previously presented) The system of claim 30 wherein the system includes a measure of the amount of ethanol available to control turbocharging, supercharging or spark retard when the amount of ethanol is low.

46. (previously presented) The system of claim 30 wherein the gasoline is directly injected into the cylinder.
47. (previously presented) The system of claim 30 wherein the direct injection of ethanol provides substantially a 13°C drop in temperature for every 10% of the fuel energy provided by the ethanol.
48. (previously presented) The system of claim 30 wherein the fuel management system substantially minimizes the amount of ethanol used over a drive cycle.
49. (previously presented) The system of claim 30 wherein an octane enhancement of at least four octane numbers is obtained when 20% of the fuel energy in a cylinder comes from ethanol.
50. (previously presented) The system of claim 30 wherein turbocharging or supercharging are reduced or eliminated and/or spark retard is increased when ethanol is not available.
51. (previously presented) The system of claim 30 wherein the engine is operated with substantially a stoichiometric fuel/air ratio.
52. (previously presented) The system of claim 30 wherein the ethanol is separated from a gasoline/ethanol mixture.
53. (previously presented) The system of claim 30 wherein the engine can be operated with only gasoline and knock can be avoided by reducing the maximum torque and horsepower relative to values when ethanol is directly injected into the cylinder.
54. (previously presented) The system of claim 53 wherein the horsepower is reduced by at least a factor of two.
55. (previously presented) The system of claim 30 wherein the fuel management microprocessor control system uses ethanol level in the ethanol tank as an input to control a turbocharger, supercharger or spark retard.
56. (previously presented) The system of claim 55 wherein the turbocharger, supercharger or spark retard is adjusted to prevent knock.

REMARKS

Re-examination and reconsideration of the rejections are hereby requested.

First of all, the inventors, Daniel Cohn, Leslie Bromberg, and John Heywood, and the undersigned attorney wish to thank Examiner Ali for according them a telephone interview of sufficient length to discuss fully the issues in this prosecution. At the beginning of the interview, Dr. Cohn briefly described the present technology. Dr. Cohn explained that the knock limit in a gasoline engine can be greatly extended by the direct injection of an appropriate liquid fuel anti-knock agent such as ethanol into a cylinder of the engine. The liquid fuel anti-knock agent vaporizes in the cylinder providing a substantial charge cooling effect. The cooling effect along with a higher octane number of an anti-knock agent such as ethanol extends the knock limit so that more aggressive turbo charging can be used and/or the engine can operate at a higher compression ratio without knock. In this way, substantial fuel can be saved because smaller engines can be used. Dr. Cohn explained that the change of state of the liquid fuel anti-knock agent from liquid to gas provides the predominant effect for extending the knock limit. Dr. Cohn also pointed out that in order to achieve commercial attractiveness it is important to obtain a large knock suppression effect in order to justify the inconvenience of using two tanks and two fuels. He further explained that for the same reason it was important to minimize the amount of the liquid fuel anti-knock agent, such as ethanol, that is used over the drive cycle.

At this point in the interview the rejections and references were discussed. The applicants proposed amending claim 1 to recite a liquid fuel anti-knock agent for vaporization in the cylinder to emphasize the importance of direct injection of a liquid fuel anti-knock agent. As to U.S. Patent No. 4,480,616 to Takeda, applicants pointed out that this patent teaches introducing liquid alcohol into the intake manifold of an engine. Professor Heywood explained that the alcohol would vaporize before entering the combustion chamber so could not provide the evaporative cooling as set forth in the claims as amended herein. Thus, Takeda teaches neither direct injection nor the introduction of a liquid fuel into the combustion chamber.

U.S. Patent No. 3,106,194 to Cantwell was discussed next. It was pointed out to the Examiner that alkali metal compounds are vaporized and then introduced into the engine. These alkali metal compounds are not a fuel and are not introduced in the liquid state. The Examiner pointed to Cantwell at column 1 at line 32 suggesting that water is “an auxiliary fuel.” Professor Heywood explained that water cannot be considered a fuel notwithstanding Cantwell’s characterization. In any event, Cantwell teaches nothing beyond introducing a vaporized material into the combustion chamber rather than a liquid that would not provide the change-of-state cooling effect. Next, the applicant discussed the Krauja et al. reference, U.S. Patent No. 4,721,081. This patent teaches a modified compression ignition engine for use either with 100% ethanol or with gasoline. This reference does not teach the introduction of any anti-knock agent, but rather is designed to operate on 100% ethanol.

The Examiner maintained his position that the references in combination meet the limitations in claim 1. The applicant disagreed suggesting that the examiner was making an impermissible hindsight reconstruction based on the teachings in the present application. No agreement was reached.

The applicant then addressed many of the dependent claims pointing out that the Examiner had no basis for the rejections. At this point, the Examiner indicated that he should have made a restriction requirement when he issued the office action because of a large number of embodiments. The Examiner stated that he would likely give a restriction requirement in the next office action. The undersigned attorney urged the Examiner not to issue a restriction requirement at this time suggesting that the attendant substantial delays could have a serious adverse effect upon the applicant. The undersigned attorney suggested that it would be unfair to penalize the applicant by a post office action reversal in the Examiner’s decision as to which claims he would consider. Applicants urged that if the independent claims were not allowable, that the Examiner should consider allowing the dependent claims that are clearly not met by the prior art.

During the interview, the examiner cited two new references, U.S. Patent No. 3,089,470 to Payne, and U.S. Patent No. 4,182,278 to Coakwell. The undersigned attorney has now had an

opportunity to review these references carefully and it is quite clear that the Payne reference does not suggest introducing a liquid fuel into an engine. The Examiner's attention is directed to column 3 beginning at line 15 wherein Payne states that the liquid auto-ignition suppressant "is preferably water" but that it is "to be clearly understood that any other liquid preparation suitable to suppress auto-ignition" is contemplated. The Examiner asserted that this section suggests injecting a liquid fuel. Applicants respectfully disagree. The Examiner has not shown that "any other liquid preparation to suppress auto-ignition" includes any liquid fuel.

As to the Coakwell patent, this reference teaches the addition of hydrogen peroxide to provide additional oxygen. The Examiner's attention is directed to Coakwell at column 9 beginning at line 7 where it is stated that the additional oxygen from the hydrogen peroxide "makes it possible to achieve combustion with leaner mixtures, to save fuel and to reduce air pollution by achieving more complete combustion." Thus, it is quite clear that the hydrogen peroxide is being introduced to provide free oxygen. Hydrogen peroxide is not itself a fuel.

Although Applicants and the Examiner continue to disagree about the patentability of the independent claims, claim 1 has been amended herein to incorporate the limitation of originally filed claim 17 and claim 17 has been cancelled. Thus claim 1 now includes the limitation "wherein the fuel management control system microprocessor substantially minimizes the amount of anti-knock agent used over a drive cycle." This amendment is being introduced in an effort to move prosecution forward. The specification speaks to the importance of minimizing the amount of anti-knock agent used over a drive cycle. For example, the specification beginning on the last line of page 2 states "An object of the present invention is to minimize the amount of ethanol or other anti-knock agent that is used to achieve a given level of engine efficiency increase. By restricting the use of ethanol to the relatively small fraction of time in an operating cycle when it is needed to prevent knock in a high load regime and by minimizing its use at these times, the amount of ethanol that is required can be limited to a relatively small fraction of the fuel used by the spark ignition gasoline engine." Moreover, page 3, beginning on line 23 of the specification states "Alternatively, the gasoline engine may include a knock sensor that provides a feedback signal to the fuel management microprocessor system to minimize the amount of ethanol added to prevent knock in a close loop fashion."

Claim 1 as amended herein (with the limitation of originally filed claim 17) has been examined and the Examiner rejected claim 17 as being unpatentable over Takeda in view of Cantwell. The Examiner states on page 5 of the Office Action “With regard to claim 17, Takeda discloses wherein the fuel management systems substantially minimizes the amount of anti-knock agent used over a drive cycle.” The undersigned attorney and the inventors herein have reviewed Takeda carefully and can find no teaching whatsoever that the fuel management system substantially minimizes the amount of anti-knock agent used over a drive cycle. The Applicant remains puzzled at this assertion by the Examiner since Takeda is totally silent in this regard. Further, the undersigned attorney has reviewed all of the references of record including Payne and Coakwell and can find no teaching of a fuel management system that substantially minimizes the amount of anti-knock agent used over a drive cycle. It is urged that claim 1, as amended herein, is clearly in condition for allowance and reconsideration is requested. Claims 2-16, 18-20 and 24-29 ultimately depend from amended claim 1 and are therefore also allowable.

Independent claim 30 has been amended herein to recite a source of liquid ethanol for vaporization in the cylinder to provide charge cooling and to control knock. Claim 30 as originally filed included the limitation of a fuel management control system for controlling injection of the ethanol “when engine torque is above a selected fraction of maximum torque.” During the interview, Applicant pointed out that this limitation is not present in the prior art. In the Office Action, the Examiner asserts that this limitation is disclosed by Takeda. Again, the undersigned attorney and the inventors have reviewed Takeda carefully and can find no teaching that injection is controlled “when engine torque is above a selected fraction of maximum torque.” Such a teaching, in fact, is totally lacking in Takeda. It is urged that the Examiner review Takeda again and remove this rejection or describe with specificity where and how Takeda provides such a teaching.

During the interview, many of the dependent claims were discussed. For example, claim 4 states that non-uniform deposition is obtained through direct injection and charge swirl. The Examiner states, without support, that Cantwell meets this limitation. In fact, a careful review of Cantwell reveals no teaching whatsoever concerning charge swirl. The Examiner is asked to

remove the rejection of claim 4 or to explain with specificity where and how Cantwell discloses charge swirl.

Dependent claim 6 includes the limitation “wherein the fuel management system includes a microprocessor that operates in an open-loop fashion on a predetermined correlation between required octane number enhancement and fraction of fuel provided by the anti-knock agent.” The Examiner asserts, again without support, that Takeda discloses such a limitation. The Examiner is asked to remove the rejection of claim 6 or provide, with specificity, those portions of Takeda that support the Examiner’s position.

Claim 7 requires that the gasoline engine include a knock sensor to provide a feedback signal to minimize the amount of anti-knock agent added to prevent knock in a closed-loop fashion. The Examiner rejects this claim as “optional design choice”. Reconsideration is requested. Claim 10 recites that the ethanol is mixed with a lubricant. As to this important limitation the Examiner again asserts that it is just an optional design choice. A careful review of the references of record shows no teaching or suggestion of adding a lubricant to the ethanol. Reconsideration is requested. Claim 11 adds the limitation “wherein the engine has substantial organized motion such as swirl.” The Examiner asserts, without specifics, that “Takeda discloses engine has substantial organized swirl motion” and a careful review of Takeda shows that it is lacking in any such teaching. The Examiner is asked to remove this rejection of claim 11 or explain with specificity how and where Takeda discloses the organized swirl motion limitation.

Claim 12 includes the limitation “wherein the system includes a measure of the amount of anti-knock agent in the source to control turbocharging, supercharging or spark retard when the amount of anti-knock agent is low.” The Examiner asserts that Takeda discloses this limitation. A careful review of Takeda indicates no teaching of such limitation. The Examiner is asked to point out where in Takeda this limitation is taught or suggested.

Claim 19 states that the turbocharging or supercharging are reduced or eliminated and/or spark retard is increased when the anti-knock agent is not available. The Examiner appears to conclude that Takeda includes this limitation. It is submitted that such limitation is not disclosed in Takeda. Claim 20 states that the ethanol is injected so that swirl creates a ring of ethanol. The Examiner, without support, states that Takeda discloses that swirl creates a ring of alcohol. Takeda provides no such teaching. Reconsideration is requested.

As another example of an unfounded rejection, Claim 26 states that the ethanol is separated from a gasoline/ethanol mixture. The Examiner, without support, states that Takeda discloses this limitation. It is submitted that Takeda clearly does not teach or suggest this limitation. With regard to claim 27, the Examiner asserts that Takeda teaches that the torque at which knock occurs can be increased by at least a factor of two by the direct injection of ethanol. It is submitted that such a teaching is lacking in Takeda. The Examiner also, without support, contends that Takeda teaches that horsepower of a given size engine can be at least doubled by using alcohol octane enhancement. It is submitted that Takeda provides no such teaching. The Examiner also states that the limitation in claim 29 concerning the gasoline consumption being reduced by at least 20% is also taught in Takeda. There is no such teaching in Takeda.

The Examiner has rejected the dependent claims depending from claim 30 with similarly sweeping, and unsupported, assertions about the prior art. The Examiner is asked either to remove the rejections of these dependent claims or provide a detailed set of specifics as to how the references meet the limitations in the claims depending claim 30.

In summary, in order to advance prosecution, the limitation of claim 17 has been introduced into claim 1. Claim 30 has been amended to provide more specificity. For the reasons discussed in detail above, it is submitted that the pending claims, as amended herein, are in condition for allowance. Early favorable action is requested.

Respectfully submitted,
CHOATE, HALL & STEWART LLP

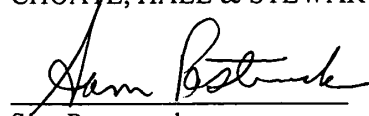

Sam Pasternack
Registration No. 29,576

Date: July 6, 2006

Patent Department
CHOATE, HALL & STEWART
Two International Place
Boston, MA 02110
Tel: (617) 248-5000
Fax: (617) 248-4000



ATTORNEY DOCKET NO.: 0492611-0598 (MIT 11381)

IN THE UNITED STATES PATENT AND TRADEMARK OFFICE

Applicant: Cohn, et al. Examiner: Ali, Hyder
Serial No.: 10,991,774 Art Unit: 3747
Filing Date: November 18, 2004
Title: FUEL MANAGEMENT SYSTEM FOR VARIABLE ETHANOL OCTANE
ENHANCEMENT OF GASOLINE ENGINES

Commissioner for Patents
P.O. Box 1450
Alexandria, VA 22313-1450

Sir:

Supplemental Information Disclosure Statement

Pursuant to the duty of disclosure under 37 C.F.R. §§1.56, 1.97 and 1.98, Applicant requests consideration of this Information Disclosure Statement.

Type of Statement

The present Information Disclosure Statement is:

- An *original* Information Disclosure Statement; or
- A *supplemental* Information Disclosure Statement.

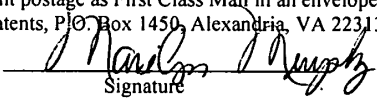
Certificate of Mailing	
I certify that this correspondence is being deposited with the United States Postal Service with sufficient postage as First Class Mail in an envelope addressed to Commissioner for Patents, P.O. Box 1450, Alexandria, VA 22313-1450.	
<u>7/6/06</u> Date	 Signature
_____ Marilyn Murphy Typed or Printed Name of person signing certificate	

07/11/2006 YPOLITE1 00000002 10991774
01 FC:1806 180.00 0P

Compliance with 37 CFR § 1.97

The present Information Disclosure Statement is being filed:

- Pursuant to 37 CFR § 1.97(b); no fee or certification is required:
 - Within three months of the filing date of a national application other than a continued prosecution application under § 1.53(d);
 - Within three months of the date of entry of the national stage as set forth in § 1.491 in an international application;
 - Before the mailing of a first Office action on the merits; or
 - Before the mailing of a first Office action after the filing of a request for continued examination under § 1.114.

Pursuant to 37 CFR § 1.97(c) after the dates listed above but before the mailing date of any of a final action under § 1.113, a notice of allowance under § 1.311, or an action that otherwise closes prosecution in the application; Applicant hereby *either*:

- Certifies that *either*:
 - each item of information contained in the information disclosure statement was first cited in any communication from a foreign patent office in a counterpart foreign application not more than three months prior to the filing of the information disclosure statement; or
 - That no item of information contained in the information disclosure statement was cited in a communication from a foreign patent office in a counterpart foreign application, and, to the knowledge of the person signing the certification after making

reasonable inquiry, no item of information contained in the information disclosure statement was known to any individual designated in § 1.56(c) more than three months prior to the filing of the information disclosure statement.; or

Includes herewith the fee set forth in § 1.17(p).

Pursuant to 37 CFR § 1.97(d), after the mailing date of any final action under § 1.113, a notice of allowance under § 1.311, or an action that otherwise closes prosecution in the application; Applicant hereby *both*:

Certifies that *either*:

each item of information contained in the information disclosure statement was first cited in any communication from a foreign patent office in a counterpart foreign application not more than three months prior to the filing of the information disclosure statement; or

That no item of information contained in the information disclosure statement was cited in a communication from a foreign patent office in a counterpart foreign application, and, to the knowledge of the person signing the certification after making reasonable inquiry, no item of information contained in the information disclosure statement was known to any individual designated in § 1.56(c) more than three months prior to the filing of the information disclosure statement.; and

Includes herewith the fee set forth in § 1.17(p).

Content of the Information Disclosure Statement

Applicant hereby makes of record in the above-identified application the reference(s) listed on the attached form PTO-1449 (modified). The order of presentation of the references should not be construed as an indication of the importance of the references.

Applicant includes copies of references as indicated below:

- A copy of each cited reference not indicated with an asterisk is included;

- Copies of references indicated with an asterisk on the attached form PTO-1449 are not included pursuant to 37 CFR § 1.98(d) because they were previously provided to the United States Patent Office in an Information Disclosure Statement that complies with 37 CFR § 1.98(a)-(c) and was submitted in the following patent application that is relied upon in the present case for an earlier effective filing date under 35 USC § 120:

Serial Number	Filing Date	Status

- Copies of English translations of one or more non-English references are included.

Applicant hereby makes the following additional information of record in the above-identified application:

Applicant certifies that the Information Disclosure Statement *either*:

- Does not contain non-English language citations;
- Does contain non-English language citations, of which the following is a concise explanation:

- Includes one or more translations of a non-English citation.

Remarks

The submission of this Information Disclosure Statement should not be construed as a representation that a search has been made.

The submission of this Information Disclosure Statement shall not be construed to be an admission that the information cited in the statement is, or is considered to be, material to patentability as defined in § 1.56(b) .

The submission of this Information Disclosure Statement shall not be construed as a representation that the information cited in the Statement is, or is considered to be, in fact, prior art as defined by 35 U.S.C. §102.

It is respectfully requested that:

1. The Examiner consider completely the cited information, along with any other information, in reaching a determination concerning the patentability of the present claims;
2. The enclosed form PTO-1449 be signed by the Examiner to evidence that the cited patent(s) and publication(s) has (have) been fully considered by the Patent and Trademark Office during the examination of this application; and
3. The citations for the patent(s) and publication(s) be printed on any patent which issues from this application.

Notwithstanding any statements by Applicants, the Examiner is urged to form his or her own conclusions regarding the relevance of the cited reference(s).

Respectfully submitted,

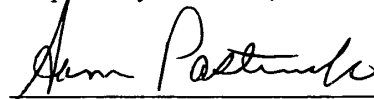

Sam Pasternack
Registration No.: 29,576

Dated: July 6, 2006

CHOATE, HALL & STEWART
2 International Place
Boston, Massachusetts 02110
(617) 248-5000
(617) 248-4000

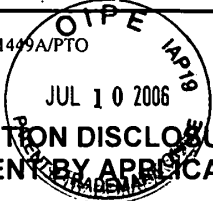
Substitute for form 1449A/PTO  INFORMATION DISCLOSURE STATEMENT BY APPLICANT (Use as many sheets as necessary)			<i>Complete if Known</i>	
			Application Number	10/991,774
			Filing Date	November 18, 2004
			First Named Inventor	Daniel R. Cohn, et al.
			Art Unit	1714
			Examiner Name	Ali, Hyder
Sheet	1	of	Attorney Docket Number	0492611-0598

U.S. PATENT DOCUMENTS					
Examiner Initials*	Cite No. ¹	Document Number	Publication Date MM-DD-YYYY	Name of Patentee or Applicant of Cited Document	Pages, Columns, Lines, Where Relevant Passages or Relevant Figures Appear
		Number-Kind Code ² (if known)			
		US 6,990,956 B2	01/31/2006	Niimi	

FOREIGN PATENT DOCUMENTS						
Examiner Initials*	Cite No. ¹	Foreign Patent Document	Publication Date MM-DD-YYYY	Name of Patentee or Applicant of Cited Document	Pages, Columns, Lines, Where Relevant Passages or Relevant Figures Appear	T ⁶
		Country Code ³ -Number ⁴ -Kind Code ⁵ (if known)				
						<input type="checkbox"/>
						<input type="checkbox"/>
						<input type="checkbox"/>
						<input type="checkbox"/>
						<input type="checkbox"/>

Examiner Signature		Date Considered	
--------------------	--	-----------------	--

*EXAMINER: Initial if reference considered, whether or not citation is in conformance with MPEP 609. Draw line through citation if not in conformance and not considered. Include copy of this form with next communication to applicant. ¹ Applicant's unique citation designation number (optional). ² See Kinds Codes of USPTO Patent Documents at www.uspto.gov or MPEP 901.04. ³ Enter Office that issued the document, by the two-letter code (WIPO Standard ST.3.) ⁴ For Japanese patent documents, the indication of the year of the reign of the Emperor must precede the serial number of the patent document. ⁵ Kind of document by the appropriate symbols as indicated on the document under WIPO Standard ST. 16 if possible. ⁶ Applicant is to place a check mark here if English language Translation is attached.

This collection of information is required by 37 CFR 1.97 and 1.98. The information is required to obtain or retain a benefit by the public which is to file (and by the USPTO to process) an application. Confidentiality is governed by 35 U.S.C. 122 and 37 CFR 1.14. This collection is estimated to take 2 hours to complete, including gathering, preparing, and submitting the completed application form to the USPTO. Time will vary depending upon the individual case. Any comments on the amount of time you require to complete this form and/or suggestions for reducing this burden, should be sent to the Chief Information Officer, U.S. Patent and Trademark Office, U.S. Department of Commerce, P.O. Box 1450, Alexandria, VA 22313-1450. DO NOT SEND FEES OR COMPLETED FORMS TO THIS ADDRESS. SEND TO: Commissioner for Patents, P.O. Box 1450, Alexandria, VA 22313-1450.

If you need assistance in completing the form, call 1-800-PTO-9199 and select option 2.

IFW



ATTORNEY'S DOCKET NUMBER: 0492611-0598

IN THE UNITED STATES PATENT AND TRADEMARK OFFICE

Applicant:	Cohn, et al.	Examiner:	Ali, Hyder
Serial No.:	10/991,774	Art Unit:	3747
Filing Date:	November 18, 2004	Conf. No.:	8282
Title:	FUEL MANAGEMENT SYSTEM FOR VARIABLE ETHANOL OCTANE ENHANCEMENT OF GASOLINE ENGINES		

Mail Stop Amendment
 Commissioner for Patents
 P.O. Box 1450
 Alexandria, VA 22313-1450

Certificate of Mailing	
I certify that this correspondence is being deposited with the United States Postal Service with sufficient postage as First Class Mail in an envelope addressed to Mail Stop Amendment, Commissioner for Patents, P.O. Box 1450, Alexandria, VA 22313-1450	
July 6, 2006	<i>Marilyn Murphy</i>
Date	Signature
Marilyn Murphy	
Typed or Printed Name of person signing certificate	

Sir:

TRANSMITTAL LETTER

Enclosed **for filing** in the above-referenced patent application, please find the following documents:

- 1) Amendment and Response to Office Action Mailed on April 25, 2006 (13 pages);
- 2) Form 1449a(PTO) (1 page);
- 3) Supplemental Information Disclosure Statement; (6 Pages)
- 4) Credit Card Form for Payment in the amount of \$180.00 (1 page);
- 5) Return-Receipt postcard (1 page).

Please charge any additional fees associated with this filing, or apply any credits, to our Deposit Account No. 03-1721.

Respectfully submitted,
CHOATE, HALL & STEWART LLP

Sam Pasternack

Sam Pasternack
Registration No. 29,576

Date: July 6, 2006
 Patent Department
 CHOATE, HALL & STEWART
 Two International Place
 Boston, MA 02110
 Tel: (617) 248-5000
 Fax: (617) 248-4000

U.S.S.N: 10/991,774

PATENT APPLICATION FEE DETERMINATION RECORD
Effective October 1, 2004

Application or Docket Number

10991774

CLAIMS AS FILED - PART I

	(Column 1)	(Column 2)
TOTAL CLAIMS	23	
FOR	NUMBER FILED	NUMBER EXTRA
TOTAL CHARGEABLE CLAIMS	23 minus 20 =	3
INDEPENDENT CLAIMS	2 minus 3 =	
MULTIPLE DEPENDENT CLAIM PRESENT	<input type="checkbox"/>	

* If the difference in column 1 is less than zero, enter "0" in column 2

SMALL ENTITY TYPE OR OTHER THAN SMALL ENTITY

RATE	FEE	OR	RATE	FEE
BASIC FEE	395.00	OR	BASIC FEE	790.00
X\$ 9=	27	OR	X\$18=	
X44=		OR	X88=	
+150=		OR	+300=	
TOTAL	422	OR	TOTAL	

CLAIMS AS AMENDED - PART II

	(Column 1)	(Column 2)	(Column 3)
AMENDMENT A	CLAIMS REMAINING AFTER AMENDMENT	HIGHEST NUMBER PREVIOUSLY PAID FOR	PRESENT EXTRA
Total	53	Minus 23	= 33
Independent	2	Minus 3	= 0
FIRST PRESENTATION OF MULTIPLE DEPENDENT CLAIM	<input type="checkbox"/>		

1 21

SMALL ENTITY OR OTHER THAN SMALL ENTITY

RATE	ADDITIONAL FEE	OR	RATE	ADDITIONAL FEE
X\$ 9=	825	OR	X\$18=	
X44=		OR	X88=	
+150=		OR	+300=	
TOTAL ADDIT. FEE	825	OR	TOTAL ADDIT. FEE	

7-10-06

	(Column 1)	(Column 2)	(Column 3)
AMENDMENT B	CLAIMS REMAINING AFTER AMENDMENT	HIGHEST NUMBER PREVIOUSLY PAID FOR	PRESENT EXTRA
Total	52	Minus 53	= -
Independent	3	Minus 3	= -
FIRST PRESENTATION OF MULTIPLE DEPENDENT CLAIM	<input type="checkbox"/>		

RATE	ADDITIONAL FEE	OR	RATE	ADDITIONAL FEE
X\$ 9=		OR	X\$18=	
X44=		OR	X88=	
+150=		OR	+300=	
TOTAL ADDIT. FEE		OR	TOTAL ADDIT. FEE	

	(Column 1)	(Column 2)	(Column 3)
AMENDMENT C	CLAIMS REMAINING AFTER AMENDMENT	HIGHEST NUMBER PREVIOUSLY PAID FOR	PRESENT EXTRA
Total		Minus	=
Independent		Minus	=
FIRST PRESENTATION OF MULTIPLE DEPENDENT CLAIM	<input type="checkbox"/>		

RATE	ADDITIONAL FEE	OR	RATE	ADDITIONAL FEE
X\$ 9=		OR	X\$18=	
X44=		OR	X88=	
+150=		OR	+300=	
TOTAL ADDIT. FEE		OR	TOTAL ADDIT. FEE	

* If the entry in column 1 is less than the entry in column 2, write "0" in column 3.
 ** If the "Highest Number Previously Paid For" IN THIS SPACE is less than 20, enter "20."
 *** If the "Highest Number Previously Paid For" IN THIS SPACE is less than 3, enter "3."
 The "Highest Number Previously Paid For" (Total or Independent) is the highest number in the appropriate box in column 1.



UNITED STATES PATENT AND TRADEMARK OFFICE

UNITED STATES DEPARTMENT OF COMMERCE
United States Patent and Trademark Office
Address: COMMISSIONER FOR PATENTS
P.O. Box 1450
Alexandria, Virginia 22313-1450
www.uspto.gov

APPLICATION NO.	FILING DATE	FIRST NAMED INVENTOR	ATTORNEY DOCKET NO.	CONFIRMATION NO.
10/991,774	11/18/2004	Daniel R. Cohn	0492611-0598	8282
24280	7590	09/27/2006	EXAMINER	
CHOATE, HALL & STEWART LLP TWO INTERNATIONAL PLACE BOSTON, MA 02110			ALI, HYDER	
			ART UNIT	PAPER NUMBER
			3747	

DATE MAILED: 09/27/2006

Please find below and/or attached an Office communication concerning this application or proceeding.

Office Action Summary	Application No. 10/991,774	Applicant(s) COHN ET AL.	
	Examiner HYDER ALI	Art Unit 3747	

-- The MAILING DATE of this communication appears on the cover sheet with the correspondence address --
Period for Reply

A SHORTENED STATUTORY PERIOD FOR REPLY IS SET TO EXPIRE 3 MONTH(S) OR THIRTY (30) DAYS, WHICHEVER IS LONGER, FROM THE MAILING DATE OF THIS COMMUNICATION.

- Extensions of time may be available under the provisions of 37 CFR 1.136(a). In no event, however, may a reply be timely filed after SIX (6) MONTHS from the mailing date of this communication.
- If NO period for reply is specified above, the maximum statutory period will apply and will expire SIX (6) MONTHS from the mailing date of this communication.
- Failure to reply within the set or extended period for reply will, by statute, cause the application to become ABANDONED (35 U.S.C. § 133). Any reply received by the Office later than three months after the mailing date of this communication, even if timely filed, may reduce any earned patent term adjustment. See 37 CFR 1.704(b).

Status

- 1) Responsive to communication(s) filed on 10 July 2006.
2a) This action is **FINAL**. 2b) This action is non-final.
3) Since this application is in condition for allowance except for formal matters, prosecution as to the merits is closed in accordance with the practice under *Ex parte Quayle*, 1935 C.D. 11, 453 O.G. 213.

Disposition of Claims

- 4) Claim(s) 1-16, 18-20 and 24-56 is/are pending in the application.
4a) Of the above claim(s) _____ is/are withdrawn from consideration.
5) Claim(s) _____ is/are allowed.
6) Claim(s) 1-16, 18-20 and 24-56 is/are rejected.
7) Claim(s) _____ is/are objected to.
8) Claim(s) _____ are subject to restriction and/or election requirement.

Application Papers

- 9) The specification is objected to by the Examiner.
10) The drawing(s) filed on 18 November 2004 is/are: a) accepted or b) objected to by the Examiner.
Applicant may not request that any objection to the drawing(s) be held in abeyance. See 37 CFR 1.85(a).
Replacement drawing sheet(s) including the correction is required if the drawing(s) is objected to. See 37 CFR 1.121(d).
11) The oath or declaration is objected to by the Examiner. Note the attached Office Action or form PTO-152.

Priority under 35 U.S.C. § 119

- 12) Acknowledgment is made of a claim for foreign priority under 35 U.S.C. § 119(a)-(d) or (f).
a) All b) Some * c) None of:
1. Certified copies of the priority documents have been received.
2. Certified copies of the priority documents have been received in Application No. _____.
3. Copies of the certified copies of the priority documents have been received in this National Stage application from the International Bureau (PCT Rule 17.2(a)).
* See the attached detailed Office action for a list of the certified copies not received.

Attachment(s)

- | | |
|--|---|
| 1) <input checked="" type="checkbox"/> Notice of References Cited (PTO-892) | 4) <input type="checkbox"/> Interview Summary (PTO-413)
Paper No(s)/Mail Date. _____ |
| 2) <input type="checkbox"/> Notice of Draftsperson's Patent Drawing Review (PTO-948) | 5) <input type="checkbox"/> Notice of Informal Patent Application |
| 3) <input checked="" type="checkbox"/> Information Disclosure Statement(s) (PTO/SB/08)
Paper No(s)/Mail Date <u>7/10/06</u> . | 6) <input type="checkbox"/> Other: _____ |

DETAILED ACTION

Inventorship

This application currently names joint inventors. In considering patentability of the claims under 35 U.S.C. 103(a), the examiner presumes that the subject matter of the various claims was commonly owned at the time any inventions covered therein were made absent any evidence to the contrary. Applicant is advised of the obligation under 37 CFR 1.56 to point out the inventor and invention dates of each claim that was not commonly owned at the time a later invention was made in order for the examiner to consider the applicability of 35 U.S.C. 103(c) and potential 35 U.S.C. 102(e), (f) or (g) prior art under 35 U.S.C. 103(a).

Claim Objections

The subject matter of independent claim 30 such as "engine torque is above a selected fraction of maximum torque" must be shown or cancelled.

The subject matter of claim 2, such as "the injectors deposit the anti-knock agent to provide non-uniform deposition within a cylinder" must be shown or cancelled.

The subject matter of claim 3, such as "the anti-knock agent is deposited near the walls of the cylinder" must be shown or cancelled.

The subject matter of claim 9, such as "ethanol is mixed with water" must be shown or cancelled.

The subject matter of claim 10, such as "ethanol is mixed with a lubricant" must be shown or cancelled.

The subject matter of claim 11, such as “the engine has substantial organized motion such as swirl” **should read** “the engine has substantial organized motion”.

The subject matter of claim 15, such as “the gasoline is directly injected into the cylinder” must be shown or cancelled.

The subject matter of dependent claims 12,19,45,50,55,56 such as “turbocharging and /or supercharging” is not clear because independent claims 1 and 30 are not a turbocharged and/or supercharged engine.

The subject matter of claim 20, such as “swirl creates a ring of ethanol” must be shown or cancelled.

The subject matter of claim 53,54, such as “torque and/or horsepower” must be shown or cancelled.

Claim Rejections - 35 USC § 103

The following is a quotation of 35 U.S.C. 103(a) which forms the basis for all obviousness rejections set forth in this Office action:

(a) A patent may not be obtained though the invention is not identically disclosed or described as set forth in section 102 of this title, if the differences between the subject matter sought to be patented and the prior art are such that the subject matter as a whole would have been obvious at the time the invention was made to a person having ordinary skill in the art to which said subject matter pertains. Patentability shall not be negated by the manner in which the invention was made.

1. Claims 1-3,5,7,8,12-16,18,19,24-36,38-40,45-56 are rejected under 35 U.S.C. 103(a) as being unpatentable over Watanabe et al (US 6,513,505) in view of Jessel (US 4,541,383).

Watanabe et al discloses fuel management system for operation of a spark ignition gasoline engine comprising: a gasoline engine; a source of a liquid fuel anti-knock agent

9; an injector 2 for direct injection of the liquid fuel anti-knock agent into a cylinder of the engine for vaporization in the cylinder to provide charge cooling; and a fuel management control system 30 including a microprocessor for controlling injection of the liquid fuel anti-knock agent into the cylinder; wherein the fuel management control system microprocessor substantially minimizes (**See Fig. 4 for the control of the duty ratio D of the control valve 15 when $D=D_0$ which is maximum 100% alcohol; when $D=D_1$ which is smaller than 100% alcohol; when $D=D_2$ which is also smaller than 100% alcohol. See Fig. 5 for a routine for calculating the duty ratio D of the control valve 15. This routine is executed every predetermined time by interruption. Col. 5, lines 45-66 and col. 6, lines 1-27**) the amount of anti-knock agent used over a drive cycle.

Assuming it is not inherent in the **Watanabe et al** patent that injecting anti-knock agent into the engine is for controlling engine knock during heavy load and/or during low rpm and/or when engine torque is above a selected fraction of maximum torque to control knock.

Also assuming control of the duty ratio D in the **Watanabe et al** patent is not for minimizing anti-knock agent.

Jessel discloses operating engines by injecting small, but effective, quantities of anti-knock agent into the engine in response both to detected knock and engine load conditions. When knock is detected, such small quantities of anti-knock agent are injected at rates and for time periods dependent upon the engine load condition, as measured by a quantity representative of mass airflow to the engine. **See col. 1, lines**

12-18. Jessel discloses a system for modulating or regulating the amount of anti-knock additive in relation to actual engine load condition causing engine knock. **See col. 2, lines 27-30. Jessel** discloses alcohol injector 48; controller 32; manifold pressure sensor 37; knock detector 30. Jessel also discloses a fuel management control system for controlling injection of the liquid ethanol into the cylinder when engine torque is above a selected fraction of maximum torque to control knock.

It would have been obvious to a person having an ordinary skill in the art to modify **Watanabe et al** by employing operating engines by injecting small, but effective, quantities of anti-knock agent into the engine in response both to detected knock and engine load conditions as taught by **Jessel**. Motivation to do so would have been to minimize anti-knock agent during the drive cycle while preventing engine knocking.

With regard to claim 2, Watanabe et al discloses the injectors will deposit the anti-knock agent to provide non-uniform deposition within cylinders.

With regard to claim 3, Watanabe et al discloses the anti-knock agent is deposited near the walls of the cylinders.

With regard to claim 5, Watanabe et al discloses anti-knock agent is alcohol.

With regard to claim 7, Jessel discloses wherein the gasoline engine includes a knock sensor 30 providing a feedback signal to a fuel management microprocessor to minimize the amount of the anti-knock agent added to prevent knock in a closed loop fashion.

With regard to claim 8, Watanabe et al discloses anti-knock agent is alcohol such as ethanol.

With regard to claims 12,19,45,50,55,56 wherein turbocharging or supercharging are reduced or eliminated and/or spark retard is increased when the anti-knock agent is not available **(inherently and necessary present in Watanabe et al patent and/or Jessel patent and/or obvious matter of design choice and/or turbocharging or supercharging should be cancelled because independents claims 1,30 are not turbocharged and/or supercharged engine).**

With regard to claim 13, Jessel discloses the high octane fuel is added only during portions of a drive cycle requiring knock resistance.

With regard to claim 14, Jessel discloses wherein gasoline is port injected into the engine.

With regard to claim 15, Watanabe et al discloses wherein the gasoline is directly injected into the cylinder.

With regard to claims 16 and 47, wherein the direct injection of ethanol provides substantially a 13 degrees Celsius drop in temperature for every 10% of fuel energy provided by the ethanol (optional design choice if it is not inherently and necessary present in Watanabe et al patent).

With regard to claim 48, Jessel discloses wherein the fuel management system substantially minimizes the amount of anti-knock agent used over a drive cycle.

With regard to claims 18 and 49, wherein an octane enhancement of at least 4 octane numbers is obtained when 20% of the fuel energy in a cylinder comes from ethanol (optional design choice if it is not inherently and necessary present in Jessel patent and/or Watanabe et al patent).

With regard to claims 24,51, Watanabe et al and Jessel both discloses wherein the engine is operated with substantially a stoichiometric air/fuel ratio.

With regard to claim 25, Jessel discloses wherein the alcohol such as ethanol is added only during portions of the drive cycle requiring knock resistance and its use is minimized during those times.

With regard to claims 26,52, Watanabe et al discloses wherein the ethanol is separated from a gasoline/alcohol (ethanol) mixture.

With regard to claim 27, wherein torque of the engine at which knock occurs can be increased by at least a factor of two by the direct injection of ethanol (optional design choice if it is not inherently and necessary present in Watanabe et al patent).

With regard to claim 28, wherein horsepower of a given size engine can be at least doubled by using alcohol (ethanol) octane enhancement (optional design choice if it is not inherently and necessary present in Watanabe et al patent).

With regard to claim 29, wherein gasoline consumption is reduced by at least 20% due to higher efficiency engine operation (optional design choice if it is not inherently and necessary present in Watanabe et al patent).

With regard to claim 30, **as discussed above**, Jessel discloses injecting ethanol into the engine when engine torque is above a selected fraction of maximum torque to control knock and Watanabe et al discloses direct injection of the ethanol into the cylinder of an engine.

With regard to claim 31, Jessel discloses wherein torque levels at which the ethanol is directly injected are those where knock would occur absent the ethanol injection.

With regard to claim 32, combining the teaching of Watanabe et al and Jessel discloses wherein the fraction of total fuel provided by the directly injected ethanol increases with increasing torque.

With regard to claim 33, Jessel discloses wherein gasoline is port fuel injected.

With regard to claim 34, both Watanabe et al and Jessel discloses wherein up to and including substantially 100% of the fuel can be **(intended use and/or functional language)** provided by the ethanol.

With regard to claim 35, both Watanabe et al and Jessel discloses wherein octane number is enhanced with increasing torque.

With regard to claim 36, wherein an octane enhancement of more than 20 octane numbers is achieved (optional design choice if it is not disclose by Watanabe et al patent and/or Jessel patent).

With regard to claim 38, Jessel wherein the gasoline engine includes a knock sensor 30 providing a feedback signal to a fuel management microprocessor to minimize the amount of the anti-knock agent added to prevent knock in a closed loop fashion.

With regard to claim 39, Watanabe et al discloses wherein the injectors 2 provide non-uniform deposition of the ethanol within a cylinder.

With regard to claim 40, Watanabe et al discloses wherein the ethanol is deposited near the walls of the cylinder.

With regard to claim 46, Watanabe et al discloses wherein the gasoline is directly injected into the cylinder.

With regard to claim 53, Watanabe et al discloses wherein the engine can be operated with only gasoline and knock can be avoided by reducing the maximum torque and horsepower relative to values when alcohol (ethanol) is directly injected into the cylinder.

With regard to claim 54, both Watanabe et al and Jessel discloses wherein the horsepower is reduced by at least a factor of two.

2. Claims 4,11,20,41,44 are rejected under 35 U.S.C. 103(a) as being unpatentable over Watanabe et al (US 6,513,505) in view of Jessel (US 4,541,383) as applied to claims 1-3,5,7,8,12-16,18,19,24-36,38-40,45-56 above, and further in view of Nakakita et al (US 6,799,551).

Watanabe et al in view of Jessel does not disclose swirl in the combustion chamber. Nakakita et al discloses as shown in FIG. 2 a state of the vertically stratified intake gas charge consisting of the swirl flows of the first and second intake gases 11,12 of different compositions. See col. 5, lines 5-10.

It would have been obvious to one of ordinary skill in the art at the time of the invention was made to further modify the invention of Watanabe et al by employing swirl in the combustion chamber as taught by Nakakita et al in order to provide Watanabe et al engine combustion chamber with non-uniform deposition of fuel.

3. Claims 6,37 are rejected under 35 U.S.C. 103(a) as being unpatentable over Watanabe et al (US 6,513,505) in view of Jessel (US 4,541,383) as applied to

claims 1-3,5,7,8,12-16,18,19,24-36,38-40,45-56 above, and further in view of Uhl et al (US 6,892,691).

Watanabe et al in view of Jessel does not disclose control apparatus with a microprocessor which has a program stored in a storage medium, which program is suited to carry out the entire control (**open loop**) of the engine.

Uhl et al discloses control apparatus 16 with a microprocessor which has a program stored in a storage medium, which program is suited to carry out the entire control (open loop) of the engine 1. See col. 3, lines 31-55.

It would have been obvious to one of ordinary skill in the art at the time of the invention was made to further modify the invention of Watanabe et al by employing open loop control as taught by Uhl et al in order to provide Watanabe et al engine control apparatus with a microprocessor which has a program stored in a storage medium, which program is suited to carry out the entire control (open loop) of the engine.

4. Claims 9,10,42,43 are rejected under 35 U.S.C. 103(a) as being unpatentable over Watanabe et al (US 6,513,505) in view of Jessel (US 4,541,383) as applied to claims 1-3,5,7,12-16,18,19,24-36,38-40,45-56 above, and further in view of Fosseen (US 4,958,598).

Watanabe et al in view of Jessel does not disclose ethanol is mixed with water as claimed in claims 9 and/or 42 and/or ethanol is mixed with lubricant as claimed in claims 10 and/or 43.

Fosseen discloses a mixture of water and ethanol, in the ratio to provide approximately

an eighty proof mixture, and a small amount of water-soluble oil, is held in a reservoir or fuel tank.. **See col. 2, lines 34-37.**

It would have been obvious to one of ordinary skill in the art at the time of the invention was made to further modify the invention of Watanabe et al by employing ethanol is mixed with water and/or oil as taught by Fosseen in order to replace the ethanol of Watanabe et al patent with a mixture of ethanol and water and/or mixture of ethanol, water and oil.

Response to Arguments

Applicant's arguments with respect to claims 1-16,18-20,24-56 have been considered but are moot in view of the new ground(s) of rejection.

Conclusion

Applicant's amendment necessitated the new ground(s) of rejection presented in this Office action. Accordingly, **THIS ACTION IS MADE FINAL.** See MPEP § 706.07(a). Applicant is reminded of the extension of time policy as set forth in 37 CFR 1.136(a).

A shortened statutory period for reply to this final action is set to expire THREE MONTHS from the mailing date of this action. In the event a first reply is filed within TWO MONTHS of the mailing date of this final action and the advisory action is not mailed until after the end of the THREE-MONTH shortened statutory period, then the shortened statutory period will expire on the date the advisory action is mailed, and any extension fee pursuant to 37 CFR 1.136(a) will be calculated from the mailing date of

Art Unit: 3747

the advisory action. In no event, however, will the statutory period for reply expire later than SIX MONTHS from the date of this final action.

Any inquiry concerning this communication or earlier communications from the examiner should be directed to HYDER ALI whose telephone number is (571) 272-4836. The examiner can normally be reached on M-F (8:30-5:00). The fax phone number for the organization where this application or proceeding is assigned is 571-273-8300. Information regarding the status of an application may be obtained from the Patent Application Information Retrieval (PAIR) system. Status information for published applications may be obtained from either Private PAIR or Public PAIR. Status information for unpublished applications is available through Private PAIR only. For more information about the PAIR system, see <http://pair-direct.uspto.gov>. Should you have questions on access to the Private PAIR system, contact the Electronic Business Center (EBC) at 866-217-9197 (toll-free).



ha

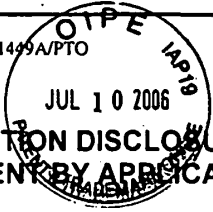

STEPHEN K. CRONIN
SUPERVISORY PATENT EXAMINER

Substitute for form 1449A/PTO  INFORMATION DISCLOSURE STATEMENT BY APPLICANT (Use as many sheets as necessary)			<i>Complete if Known</i>	
			Application Number	10/991,774
			Filing Date	November 18, 2004
			First Named Inventor	Daniel R. Cohn, et al.
			Art Unit	1714
			Examiner Name	Ali, Hyder
Sheet	1	of	Attorney Docket Number	0492611-0598

U.S. PATENT DOCUMENTS					
Examiner Initials*	Cite No. ¹	Document Number	Publication Date MM-DD-YYYY	Name of Patentee or Applicant of Cited Document	Pages, Columns, Lines, Where Relevant Passages or Relevant Figures Appear
		Number-Kind Code ² (if known)			
HA		US 6,990,956 B2	01/31/2006	Niimi	

FOREIGN PATENT DOCUMENTS						
Examiner Initials*	Cite No. ¹	Foreign Patent Document	Publication Date MM-DD-YYYY	Name of Patentee or Applicant of Cited Document	Pages, Columns, Lines, Where Relevant Passages or Relevant Figures Appear	T ⁶
		Country Code ³ -Number ⁴ -Kind Code ⁵ (if known)				
						<input type="checkbox"/>
						<input type="checkbox"/>
						<input type="checkbox"/>
						<input type="checkbox"/>
						<input type="checkbox"/>

Examiner Signature	/Hyder Ali/	Date Considered	07/21/2006
--------------------	-------------	-----------------	------------

*EXAMINER: Initial if reference considered, whether or not citation is in conformance with MPEP 609. Draw line through citation if not in conformance and not considered. Include copy of this form with next communication to applicant. ¹ Applicant's unique citation designation number (optional). ² See Kinds Codes of USPTO Patent Documents at www.uspto.gov or MPEP 901.04. ³ Enter Office that issued the document, by the two-letter code (WIPO Standard ST.3.) ⁴ For Japanese patent documents, the indication of the year of the reign of the Emperor must precede the serial number of the patent document. ⁵ Kind of document by the appropriate symbols as indicated on the document under WIPO Standard ST. 16 if possible. ⁶ Applicant is to place a check mark here if English language Translation is attached.

This collection of information is required by 37 CFR 1.97 and 1.98. The information is required to obtain or retain a benefit by the public which is to file (and by the USPTO to process) an application. Confidentiality is governed by 35 U.S.C. 122 and 37 CFR 1.14. This collection is estimated to take 2 hours to complete, including gathering, preparing, and submitting the completed application form to the USPTO. Time will vary depending upon the individual case. Any comments on the amount of time you require to complete this form and/or suggestions for reducing this burden, should be sent to the Chief Information Officer, U.S. Patent and Trademark Office, U.S. Department of Commerce, P.O. Box 1450, Alexandria, VA 22313-1450. DO NOT SEND FEES OR COMPLETED FORMS TO THIS ADDRESS. SEND TO: Commissioner for Patents, P.O. Box 1450, Alexandria, VA 22313-1450.

If you need assistance in completing the form, call 1-800-PTO-9199 and select option 2.

Notice of References Cited	Application/Control No. 10/991,774	Applicant(s)/Patent Under Reexamination COHN ET AL.	
	Examiner HYDER ALI	Art Unit 3747	Page 1 of 1

U.S. PATENT DOCUMENTS

*	Document Number Country Code-Number-Kind Code	Date MM-YYYY	Name	Classification
*	A US-6,513,505	02-2003	Watanabe et al.	123/525
*	B US-4,541,383	09-1985	Jessel, Alfred J.	123/435
*	C US-6,799,551	10-2004	Nakakita et al.	123/295
*	D US-6,892,691	05-2005	Uhl et al.	123/198A
*	E US-4,958,598	09-1990	Fosseen, Dwayne	123/1A
	F US-			
	G US-			
	H US-			
	I US-			
	J US-			
	K US-			
	L US-			
	M US-			

FOREIGN PATENT DOCUMENTS

*	Document Number Country Code-Number-Kind Code	Date MM-YYYY	Country	Name	Classification
	N				
	O				
	P				
	Q				
	R				
	S				
	T				

NON-PATENT DOCUMENTS

*	Document Number Country Code-Number-Kind Code	Date MM-YYYY	Country	Name	Classification
	Include as applicable: Author, Title Date, Publisher, Edition or Volume, Pertinent Pages)				
	U				
	V				
	W				
	X				

*A copy of this reference is not being furnished with this Office action. (See MPEP § 707.05(a).)
Dates in MM-YYYY format are publication dates. Classifications may be US or foreign.



UNITED STATES PATENT AND TRADEMARK OFFICE

UNITED STATES DEPARTMENT OF COMMERCE
 United States Patent and Trademark Office
 Address: COMMISSIONER FOR PATENTS
 P.O. Box 1450
 Alexandria, Virginia 22313-1450
 www.uspto.gov



Bib Data Sheet

CONFIRMATION NO. 8282

SERIAL NUMBER 10/991,774	FILING DATE 11/18/2004 RULE	CLASS 123	GROUP ART UNIT 3747	ATTORNEY DOCKET NO. 0492611-0598	
APPLICANTS Daniel R. Cohn, Chestnut Hill, MA; Leslie Bromberg, Sharon, MA; John B. Heywood, Newton, MA; ** CONTINUING DATA ***** NONE ** FOREIGN APPLICATIONS ***** NONE IF REQUIRED, FOREIGN FILING LICENSE GRANTED ** SMALL ENTITY ** ** 03/01/2005					
Foreign Priority claimed <input type="checkbox"/> yes <input checked="" type="checkbox"/> no	35 USC 119 (a-d) conditions met <input checked="" type="checkbox"/> yes <input type="checkbox"/> no	STATE OR COUNTRY MA	SHEETS DRAWING 3	TOTAL CLAIMS 56	INDEPENDENT CLAIMS 2
Verified and Acknowledged Examiner's Signature: <i>H. A. M.</i> Initials: <i>HA</i>		ADDRESS 24280 CHOATE, HALL & STEWART LLP TWO INTERNATIONAL PLACE BOSTON, MA 02110			
TITLE Fuel management system for variable ethanol octane enhancement of gasoline engines					
FILING FEE RECEIVED 1312	FEES: Authority has been given in Paper No. _____ to charge/credit DEPOSIT ACCOUNT No. _____ for following:		<input type="checkbox"/> All Fees <input type="checkbox"/> 1.16 Fees (Filing) <input type="checkbox"/> 1.17 Fees (Processing Ext. of time) <input type="checkbox"/> 1.18 Fees (Issue) <input type="checkbox"/> Other _____ <input type="checkbox"/> Credit		

<http://neo:8000/PrexServlet/PrexAction?serviceName=BibDataSheet&Action=display&brow...> 4/17/06

Search Notes



Application/Control No.

10/991,774

Examiner

HYDER ALI

Applicant(s)/Patent under Reexamination

COHN ET AL.

Art Unit

3747

SEARCHED

Class	Subclass	Date	Examiner
123	1A	4/17/2006	HA
123	198A	4/17/2006	HA
123	525	4/17/2006	HA
123	25A	4/17/2006	HA
123	25J	4/17/2006	HA
123	435	9/19/06	HA
123	575	9/19/06	HA
123	406.29	9/19/06	HA
123	406.47	9/19/06	HA
UPDATED		9/19/06	HA

INTERFERENCE SEARCHED

Class	Subclass	Date	Examiner

**SEARCH NOTES
(INCLUDING SEARCH STRATEGY)**

	DATE	EXMR
SEARCHED EAST SEE EAST SEARCH PRINT OUT.	4/17/2006	HA

Index of Claims



Application/Control No.

10/991,774

Examiner

HYDER ALI

Applicant(s)/Patent under Reexamination

COHN ET AL.

Art Unit

3747

✓	Rejected
=	Allowed

-	(Through numeral) Cancelled
+	Restricted

N	Non-Elected
I	Interference

A	Appeal
O	Objected

Claim		Date			
Final	Original				
	1	✓	✓		
	2	✓	✓		
	3	✓	✓		
	4	✓	✓		
	5	✓	✓		
	6	✓	✓		
	7	✓	✓		
	8	✓	✓		
	9	✓	✓		
	10	✓	✓		
	11	✓	✓		
	12	✓	✓		
	13	✓	✓		
	14	✓	✓		
	15	✓	✓		
	16	✓	✓		
	17	✓	✓		
	18	✓	✓		
	19	✓	✓		
	20	✓	✓		
	21	✓	✓		
	22	✓	✓		
	23	✓	✓		
	24	✓	✓		
	25	✓	✓		
	26	✓	✓		
	27	✓	✓		
	28	✓	✓		
	29	✓	✓		
	30	✓	✓		
	31	✓	✓		
	32	✓	✓		
	33	✓	✓		
	34	✓	✓		
	35	✓	✓		
	36	✓	✓		
	37	✓	✓		
	38	✓	✓		
	39	✓	✓		
	40	✓	✓		
	41	✓	✓		
	42	✓	✓		
	43	✓	✓		
	44	✓	✓		
	45	✓	✓		
	46	✓	✓		
	47	✓	✓		
	48	✓	✓		
	49	✓	✓		
	50	✓	✓		

Claim		Date			
Final	Original				
	51	✓	✓		
	52	✓	✓		
	53	✓	✓		
	54	✓	✓		
	55	✓	✓		
	56	✓	✓		
	57	✓	✓		
	58	✓	✓		
	59	✓	✓		
	60	✓	✓		
	61	✓	✓		
	62	✓	✓		
	63	✓	✓		
	64	✓	✓		
	65	✓	✓		
	66	✓	✓		
	67	✓	✓		
	68	✓	✓		
	69	✓	✓		
	70	✓	✓		
	71	✓	✓		
	72	✓	✓		
	73	✓	✓		
	74	✓	✓		
	75	✓	✓		
	76	✓	✓		
	77	✓	✓		
	78	✓	✓		
	79	✓	✓		
	80	✓	✓		
	81	✓	✓		
	82	✓	✓		
	83	✓	✓		
	84	✓	✓		
	85	✓	✓		
	86	✓	✓		
	87	✓	✓		
	88	✓	✓		
	89	✓	✓		
	90	✓	✓		
	91	✓	✓		
	92	✓	✓		
	93	✓	✓		
	94	✓	✓		
	95	✓	✓		
	96	✓	✓		
	97	✓	✓		
	98	✓	✓		
	99	✓	✓		
	100	✓	✓		

Claim		Date			
Final	Original				
	101				
	102				
	103				
	104				
	105				
	106				
	107				
	108				
	109				
	110				
	111				
	112				
	113				
	114				
	115				
	116				
	117				
	118				
	119				
	120				
	121				
	122				
	123				
	124				
	125				
	126				
	127				
	128				
	129				
	130				
	131				
	132				
	133				
	134				
	135				
	136				
	137				
	138				
	139				
	140				
	141				
	142				
	143				
	144				
	145				
	146				
	147				
	148				
	149				
	150				



CHOATE HALL & STEWART LLP

RECEIVED
CENTRAL FAX CENTER

NOV 30 2006

Fax

Recipient	Company	Fax	Phone
Commissioner for Patents	USPTO	571-273-8300	571-272-2600
From	Sam Pasternack	Number of Pages	9 (including fax cover sheet)
Date	November 30, 2006	Client Number	0492611-0598
Phone	617-248-5000	Operator	Elizabeth Burke
		Time Sent	

Comments Applicant: Cohn, et al. Examiner: Hyder Ali
 Serial No.: 10/991,774 Art Unit: 3747
 Filing Date: November 18, 2004
 Title: **FUEL MANAGEMENT SYSTEM FOR VARIABLE ETHANOL
 OCTANE ENHANCEMENT OF GASOLINE ENGINES**

Transmitted herewith for filing in the above-referenced application, please find the following documents:

- 1) Amendment After Final Action (8 pages); and
- 2) This Transmittal (1 page).

Applicants believe no fees are due at this time. However, Please charge any additional fees or credit any overpayments to our Deposit Account No. 03-1721.

Kindly acknowledge receipt of the attached documents by return facsimile transmission.

Thank you for your kind attention to this request.

Respectfully Submitted,

Sam Pasternack
Reg. No. 29,576

Return by Inter-office Mail Hold for pick-up

Two International Place | Boston MA 02110 | t 617-248-5000 | f 617-248-4000 | choate.com
4149692v1

RECEIVED
CENTRAL FAX CENTER

NOV 30 2006

Attorney Docket No: 0492611-0598

IN THE UNITED STATES PATENT AND TRADEMARK OFFICE

Applicant: Cohn, et al. Examiner: Hyder Ali
Serial No.: 10/991,774 Art Unit: 3747
Filing Date: November 18, 2004

Title: **FUEL MANAGEMENT SYSTEM FOR VARIABLE ETHANOL
OCTANE ENHANCEMENT OF GASOLINE ENGINES**

Commissioner for Patents
P.O. Box 1450
Alexandria, VA 22313-1450

Sir:

Certificate of Facsimile Transmission	
I certify that this correspondence is being transmitted via facsimile to (mail stop if applicable) Commissioner for Patents, P.O. Box 1450, Alexandria, VA 22313-1450, via facsimile no. 571-273-8300	
November 30, 2006	
Date	Signature
Elizabeth Burke Typed or Printed Name of person signing certificate	

AMENDMENT AFTER FINAL ACTION

In response to the Office Action mailed September 27, 2006 finally rejecting the pending claims, it is requested that this amendment be entered and the application allowed:

Amendments to the Claims are reflected in the listing of claims that begins on page 2 of this paper.

Remarks begin on page 7 of this paper.

Amendment to the Claims

Claims 1-56 cancelled.

Claim 57. (New) A turbocharged, spark ignition engine which uses port fuel injection of gasoline from a first source in addition to direct fuel injection of liquid denatured ethanol from a second source comprising:

a spark ignition engine;

a turbocharger;

means for port fuel injection of gasoline from the first source;

means for direct fuel injection of liquid denatured ethanol from the second source;

wherein during part of engine operating time, the engine is powered both by gasoline that is port fuel injected and ethanol that is directly injected; and

wherein during part of the operating time the instantaneous ethanol energy fraction is at least 20%; and

wherein the ethanol is directly injected in an amount such that the evaporative cooling of the fuel/air charge by the directly injected ethanol combined with the higher octane number of the ethanol enhances the octane number by at least 20 octane numbers; and

a fuel management system including a microprocessor which increases the ethanol energy fraction with increasing torque so that it is sufficient to prevent knock; and

wherein the fuel management system uses closed loop control with information from a knock detector to vary the ethanol energy fraction when the instantaneous ethanol fraction is at least 20%; and

wherein the fuel management system minimizes the ethanol use by using information from the knock detector; and

wherein the turbocharged direct injection spark ignition engine is operated at a substantially stoichiometric air/fuel ratio; and

wherein the fuel management microprocessor uses information about the ethanol level in the second source to control the turbocharger; and

wherein the turbocharging is eliminated or reduced when there is no ethanol in the second source; and

Page 2 of 8

4149358v1

wherein a vehicle with this spark ignition engine can be operated on port fuel injected gasoline alone without knock.

Claim 58. (New) A turbocharged, spark ignition engine which uses port fuel injection of gasoline from a first source in addition to direct fuel injection of liquid denatured ethanol from a second source comprising:

a spark ignition engine;

a turbocharger;

means for port fuel injection of gasoline from the first source;

means for direct fuel injection of liquid denatured ethanol from the second source;

wherein during part of the engine operating time, the engine is powered both by gasoline that is port fuel injected and ethanol that is directly injected; and

wherein during part of the operating time the instantaneous ethanol energy fraction is at least 20%; and

wherein the ethanol is directly injected in such an amount that the evaporative cooling of the fuel/air charge by the directly injected ethanol combined with the higher octane number of the ethanol enhances the octane number by at least 20 octane numbers; and

a fuel management system including a microprocessor which increases the ethanol energy fraction with increasing torque so that it is sufficient to prevent knock; and

wherein the fuel management system uses the combination of open loop control using a look up table and closed loop control using a knock detector to vary the ethanol energy fraction; and

wherein the fuel management system minimizes the ethanol use by using information from the knock detector; and

wherein the turbocharged direct injection spark ignition engine is operated at a substantially stoichiometric air/fuel ratio; and

wherein the fuel management microprocessor uses information about the level of ethanol in the second source to control the turbocharger; and

and further wherein the turbocharging is eliminated or reduced when there is no ethanol in the second source; and

wherein a vehicle using this engine can be operated on port fueled gasoline alone without knock; and

further wherein liquid ethanol is directly injected in an amount such that the turbocharged spark ignition engine is operated without knock at a horsepower level which is at least twice the horsepower level without knock as is the case when it is when operated with port fuel injected gasoline alone.

Claim 59. (New) A turbocharged, spark ignition engine which uses port fuel injection of gasoline from a first source in addition to direct fuel injection of liquid denatured ethanol from a second source comprising:

a spark ignition engine;

a turbocharger;

means for port fuel injection of gasoline from the first source;

means for direct injection of liquid denatured ethanol from the second source;

wherein during part of the engine operating time, the engine is powered both by gasoline that is port fuel injected and ethanol that is directly injected; and

wherein during part of the operating time the instantaneous ethanol energy fraction is at least 20%; and

wherein the ethanol is directly injected in an amount such that the evaporative cooling of the fuel/air charge by the directly injected ethanol combined with the higher octane number of the ethanol enhances the octane number by at least 20 octane numbers; and

a fuel management system including a microprocessor which increases the ethanol energy fraction with increasing torque so that it is sufficient to prevent knock; and

wherein the fuel management system uses the combination of open loop control using a look up table and closed loop control using a knock detector to vary the ethanol energy fraction; and

wherein the fuel management system minimizes ethanol use by using information from the knock detector; and

wherein the turbocharged direct injection spark ignition engine is operated at a substantially stoichiometric air/fuel ratio; and

wherein the fuel management system microprocessor uses information about the level of ethanol in the second source to control the turbocharger;

Page 4 of 8

4149358v1

and further wherein the turbocharging is eliminated or reduced when there is no ethanol in the second source; and

wherein a vehicle using this engine can be operated on port fueled gasoline alone without knock; and

wherein the fuel management microprocessor uses information about the level of the ethanol in the second source to control spark retard; and

where the spark retard is increased when there is no ethanol in the second source; and

further wherein liquid ethanol is directly injected in an amount such that the turbocharged spark ignition engine is operated without knock at a horsepower level which is at least twice the horsepower level without knock than is the case when it is when operated with port fuel injected gasoline alone.

Claim 60. (New) A turbocharged spark ignition engine which uses port fuel injection of gasoline from a first source in addition to direct injection of liquid denatured ethanol from a second source comprising:

a spark ignition engine;

a turbocharger;

means for port fuel injection of gasoline from the first source;

means for direct injection of liquid denatured ethanol from the second source;

wherein during part of the engine operating time, the engine is powered by a fuel that consists of both gasoline that is port fuel injected and ethanol that is directly injected; and

wherein under some operating conditions the instantaneous ethanol energy fraction is at least 20%; and

wherein the ethanol is directly injected in an amount such that the evaporative cooling of the fuel/air charge by the directly injected ethanol combined with the higher octane number of the ethanol enhances the octane number by at least 20 octane numbers; and

a fuel management system including a microprocessor which increases the ethanol energy fraction with increasing torque so that it is sufficient to prevent knock; and

wherein the fuel management system uses a combination of open loop control with a look up table and closed loop control using a knock sensor to control the ethanol energy fraction; and

wherein the open loop control uses a predetermined correlation between a required octane enhancement and the fraction of the fuel provided by ethanol;

wherein the fuel management system minimizes the ethanol use by using information from the knock sensor; and

wherein the turbocharged direct injection spark ignition engine is operated at a substantially stoichiometric air /fuel ratio;

wherein the fuel management microprocessor uses information about the level of ethanol in the second source to control the turbocharger;

and further wherein the turbocharging is eliminated or reduced when there is no ethanol in the second source; and

wherein a vehicle using this spark ignition engine can be operated on port fueled gasoline alone without knock; and

wherein the fuel management microprocessor uses information about the level of the ethanol in the second source to control spark retard; and

wherein the spark retard is increased when there is no ethanol in the second source; and

wherein the fuel management system includes a measure of the ethanol in the second source to control turbocharging when the amount of ethanol is low; and

wherein the fuel management system includes a measure of the ethanol in the second source to control spark retard when the amount of ethanol is low;

further wherein liquid ethanol is directly injected in an amount such that the turbocharged spark ignition engine operates without knock at a horsepower level which is at least twice the horsepower level without knock which is the case when operated with port fuel injected gasoline alone; and

wherein the engine can be operated on the denatured ethanol alone; and

wherein the ethanol fraction needed to prevent knock is reduced by concentrating the ethanol in regions that make up the end -gas and are prone to auto-ignition;

wherein the ethanol is injected so as to place the ethanol near the walls of the engine cylinder; and

wherein swirl is used to create a ring of ethanol near the walls of the cylinder; and

wherein the ethanol is mixed with a lubricant.

Remarks

It is requested that the foregoing Amendment be entered and considered.

The undersigned attorney and one of the inventors, Dr. Daniel Cohn, wish to thank examiner Ali for according them a telephone interview of sufficient length to discuss this application and a related application. The undersigned also wishes to thank examiner Cronin for a short telephone interview to address a potential 35 USC §112, 2nd paragraph issue. It is submitted that the foregoing Amendments place this application into condition for allowance.

During the interview with examiner Ali, applicants discussed Claims 57-60 forming this Amendment in relation to the cited prior art. The applicants pointed out that many of the limitations in the newly presented claims distinguish over the prior art. For example, applicants pointed out that the claims now require "means for port fuel injection of gasoline from the first source" and "means for direct fuel injection of liquid denatured alcohol from the second source." The applicants pointed out that none of the prior art references, alone or in combination, teach or suggest the combination of port fuel injection of gasoline along with direct fuel injection of liquid denatured ethanol. Other limitations that distinguish these claims from the prior art were also mentioned.

After examiner Ali asked questions concerning the teachings in the prior art, he indicated that these claims distinguish over the references. At this point, examiner Ali indicated that there could be 35 USC §112, 2nd paragraph issues raised by the claims. Examiner Ali suggested that we discuss any potential 112, 2nd paragraph, issues with his supervisor, Mr. Cronin.

During a telephone interview with Mr. Cronin, Applicant agreed that the preamble was not as clear as it could be. The undersigned suggested changing the beginning of the preamble to recite "a turbocharged spark ignition engine." The undersigned proposed making the first limitation consistent with the preamble by reciting a spark ignition engine. Examiner Cronin stated that those changes would eliminate the 35 USC §112, 2nd paragraph issues.

In response to the telephone interviews, pending Claims 1-56 have been cancelled herein and replaced with new claims 57-60. Based on the telephone interviews with examiners Ali and Cronin, it is submitted that these claims are in condition for allowance and early favorable action is requested.

Page 7 of 8

4149358v1

Respectfully submitted,
CHOATE, HALL & STEWART LLP

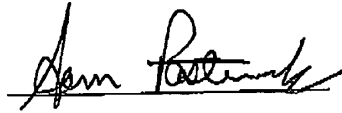

Sam Pasternack
Registration No. 29,576

Patent Department
CHOATE, HALL & STEWART, LLP
Two International Place
Boston, MA 02110
Tel: (617) 248-5000
Fax: (617) 248-4000

Dated: November 30, 2006

Page 8 of 8

4149358v1

PATENT APPLICATION FEE DETERMINATION RECORD
Effective October 1, 2004

Application or Docket Number

10991774

CLAIMS AS FILED - PART I

(Column 1) (Column 2)

TOTAL CLAIMS	23	
FOR	NUMBER FILED	NUMBER EXTRA
TOTAL CHARGEABLE CLAIMS	23 minus 20 =	3
INDEPENDENT CLAIMS	2 minus 3 =	
MULTIPLE DEPENDENT CLAIM PRESENT <input type="checkbox"/>		

* If the difference in column 1 is less than zero, enter "0" in column 2

SMALL ENTITY TYPE OR

OTHER THAN SMALL ENTITY

RATE	FEE
BASIC FEE	395.00
X59=	27
X44=	
+150=	
TOTAL	422

RATE	FEE
BASIC FEE	790.00
X518=	
X88=	
+300=	
TOTAL	

CLAIMS AS AMENDED - PART II

(Column 1) (Column 2) (Column 3)

AMENDMENT A 12/27/04

	CLAIMS REMAINING AFTER AMENDMENT		HIGHEST NUMBER PREVIOUSLY PAID FOR	PRESENT EXTRA
Total	53	Minus	23	33
Independent	2	Minus	2	0
FIRST PRESENTATION OF MULTIPLE DEPENDENT CLAIM <input type="checkbox"/>				

SMALL ENTITY OR

OTHER THAN SMALL ENTITY

RATE	ADDITIONAL FEE
X59=	825
X44=	
+150=	
TOTAL ADDIT. FEE	825

RATE	ADDITIONAL FEE
X518=	
X88=	
+300=	
TOTAL ADDIT. FEE	

1 21

7-10-06

(Column 1) (Column 2) (Column 3)

AMENDMENT B

	CLAIMS REMAINING AFTER AMENDMENT		HIGHEST NUMBER PREVIOUSLY PAID FOR	PRESENT EXTRA
Total	52	Minus	53	-
Independent	3	Minus	3	-
FIRST PRESENTATION OF MULTIPLE DEPENDENT CLAIM <input type="checkbox"/>				

RATE	ADDITIONAL FEE
X59=	
X44=	
+150=	
TOTAL ADDIT. FEE	

RATE	ADDITIONAL FEE
X518=	
X88=	
+300=	
TOTAL ADDIT. FEE	

11-30-06

(Column 1) (Column 2) (Column 3)

AMENDMENT C

	CLAIMS REMAINING AFTER AMENDMENT		HIGHEST NUMBER PREVIOUSLY PAID FOR	PRESENT EXTRA
Total	4	Minus		
Independent	4	Minus		
FIRST PRESENTATION OF MULTIPLE DEPENDENT CLAIM <input type="checkbox"/>				

RATE	ADDITIONAL FEE
X59=	
X44=	
+150=	
TOTAL ADDIT. FEE	

RATE	ADDITIONAL FEE
X518=	
X88=	
+300=	
TOTAL ADDIT. FEE	

* If the entry in column 1 is less than the entry in column 2, write "0" in column 3.
 ** If the "Highest Number Previously Paid For" IN THIS SPACE is less than 20, enter "20."
 *** If the "Highest Number Previously Paid For" IN THIS SPACE is less than 3, enter "3."
 The "Highest Number Previously Paid For" (Total or Independent) is the highest number entered in the appropriate box in column 1.



UNITED STATES PATENT AND TRADEMARK OFFICE

UNITED STATES DEPARTMENT OF COMMERCE
United States Patent and Trademark Office
Address: COMMISSIONER FOR PATENTS
P.O. Box 1450
Alexandria, Virginia 22313-1450
www.uspto.gov

APPLICATION NO.	FILING DATE	FIRST NAMED INVENTOR	ATTORNEY DOCKET NO.	CONFIRMATION NO.
10/991,774	11/18/2004	Daniel R. Cohn	0492611-0598	8282

24280 7590 12/19/2006
CHOATE, HALL & STEWART LLP
TWO INTERNATIONAL PLACE
BOSTON, MA 02110

EXAMINER

ALI, HYDER

ART UNIT	PAPER NUMBER
3747	

MAIL DATE	DELIVERY MODE
12/19/2006	PAPER

Please find below and/or attached an Office communication concerning this application or proceeding.

Advisory Action Before the Filing of an Appeal Brief	Application No. 10/991,774	Applicant(s) COHN ET AL.	
	Examiner HYDER ALI	Art Unit 3747	

--The MAILING DATE of this communication appears on the cover sheet with the correspondence address --

THE REPLY FILED 30 November 2006 FAILS TO PLACE THIS APPLICATION IN CONDITION FOR ALLOWANCE.

1. The reply was filed after a final rejection, but prior to or on the same day as filing a Notice of Appeal. To avoid abandonment of this application, applicant must timely file one of the following replies: (1) an amendment, affidavit, or other evidence, which places the application in condition for allowance; (2) a Notice of Appeal (with appeal fee) in compliance with 37 CFR 41.31; or (3) a Request for Continued Examination (RCE) in compliance with 37 CFR 1.114. The reply must be filed within one of the following time periods:

- a) The period for reply expires _____ months from the mailing date of the final rejection.
- b) The period for reply expires on: (1) the mailing date of this Advisory Action, or (2) the date set forth in the final rejection, whichever is later. In no event, however, will the statutory period for reply expire later than SIX MONTHS from the mailing date of the final rejection.

Examiner Note: If box 1 is checked, check either box (a) or (b). ONLY CHECK BOX (b) WHEN THE FIRST REPLY WAS FILED WITHIN TWO MONTHS OF THE FINAL REJECTION. See MPEP 706.07(f).

Extensions of time may be obtained under 37 CFR 1.136(a). The date on which the petition under 37 CFR 1.136(a) and the appropriate extension fee have been filed is the date for purposes of determining the period of extension and the corresponding amount of the fee. The appropriate extension fee under 37 CFR 1.17(a) is calculated from: (1) the expiration date of the shortened statutory period for reply originally set in the final Office action; or (2) as set forth in (b) above, if checked. Any reply received by the Office later than three months after the mailing date of the final rejection, even if timely filed, may reduce any earned patent term adjustment. See 37 CFR 1.704(b).

NOTICE OF APPEAL

2. The Notice of Appeal was filed on _____. A brief in compliance with 37 CFR 41.37 must be filed within two months of the date of filing the Notice of Appeal (37 CFR 41.37(a)), or any extension thereof (37 CFR 41.37(e)), to avoid dismissal of the appeal. Since a Notice of Appeal has been filed, any reply must be filed within the time period set forth in 37 CFR 41.37(a).

AMENDMENTS

- 3. The proposed amendment(s) filed after a final rejection, but prior to the date of filing a brief, will not be entered because
 - (a) They raise new issues that would require further consideration and/or search (see NOTE below);
 - (b) They raise the issue of new matter (see NOTE below);
 - (c) They are not deemed to place the application in better form for appeal by materially reducing or simplifying the issues for appeal; and/or
 - (d) They present additional claims without canceling a corresponding number of finally rejected claims.

NOTE: Claims 57-60 constitute new issue. (See 37 CFR 1.116 and 41.33(a)).

4. The amendments are not in compliance with 37 CFR 1.121. See attached Notice of Non-Compliant Amendment (PTOL-324).

5. Applicant's reply has overcome the following rejection(s): _____.

6. Newly proposed or amended claim(s) _____ would be allowable if submitted in a separate, timely filed amendment canceling the non-allowable claim(s).

7. For purposes of appeal, the proposed amendment(s): a) will not be entered, or b) will be entered and an explanation of how the new or amended claims would be rejected is provided below or appended.

The status of the claim(s) is (or will be) as follows:

Claim(s) allowed: _____.

Claim(s) objected to: _____.

Claim(s) rejected: 1-16, 18-20 and 24-56.

Claim(s) withdrawn from consideration: _____.

AFFIDAVIT OR OTHER EVIDENCE

8. The affidavit or other evidence filed after a final action, but before or on the date of filing a Notice of Appeal will not be entered because applicant failed to provide a showing of good and sufficient reasons why the affidavit or other evidence is necessary and was not earlier presented. See 37 CFR 1.116(e).

9. The affidavit or other evidence filed after the date of filing a Notice of Appeal, but prior to the date of filing a brief, will not be entered because the affidavit or other evidence failed to overcome all rejections under appeal and/or appellant fails to provide a showing a good and sufficient reasons why it is necessary and was not earlier presented. See 37 CFR 41.33(d)(1).

10. The affidavit or other evidence is entered. An explanation of the status of the claims after entry is below or attached.

REQUEST FOR RECONSIDERATION/OTHER

11. The request for reconsideration has been considered but does NOT place the application in condition for allowance because: _____.

12. Note the attached Information Disclosure Statement(s). (PTO/SB/08) Paper No(s). _____

13. Other: PTO-413 (Interview Summary).

Hyder ALI

STEPHEN K. CRONIN
SUPERVISORY PATENT EXAMINER

Interview Summary	Application No. 10/991,774	Applicant(s) COHN ET AL.	
	Examiner HYDER ALI	Art Unit 3747	

All participants (applicant, applicant's representative, PTO personnel):

- (1) HYDER ALI. (3) Dr. Daniel Cohn.
(2) Sam Pasternack. (4) _____.

Date of Interview: 27 November 2006.

Type: a) Telephonic b) Video Conference
c) Personal [copy given to: 1) applicant 2) applicant's representative]

Exhibit shown or demonstration conducted: d) Yes e) No.
If Yes, brief description: _____.

Claim(s) discussed: Proposed amendments claims 57-60.

Identification of prior art discussed: Art of record Jessel (US 4,541,383) and Watanabe et al (US 6,513,505).

Agreement with respect to the claims f) was reached. g) was not reached. h) N/A.

Substance of Interview including description of the general nature of what was agreed to if an agreement was reached, or any other comments: Examiner Ali indicated that there could be 35 USC 112, 2nd paragraph issues raised by the proposed amendments claims 57-60.

(A fuller description, if necessary, and a copy of the amendments which the examiner agreed would render the claims allowable, if available, must be attached. Also, where no copy of the amendments that would render the claims allowable is available, a summary thereof must be attached.)

THE FORMAL WRITTEN REPLY TO THE LAST OFFICE ACTION MUST INCLUDE THE SUBSTANCE OF THE INTERVIEW. (See MPEP Section 713.04). If a reply to the last Office action has already been filed, APPLICANT IS GIVEN A NON-EXTENDABLE PERIOD OF THE LONGER OF ONE MONTH OR THIRTY DAYS FROM THIS INTERVIEW DATE, OR THE MAILING DATE OF THIS INTERVIEW SUMMARY FORM, WHICHEVER IS LATER, TO FILE A STATEMENT OF THE SUBSTANCE OF THE INTERVIEW. See Summary of Record of Interview requirements on reverse side or on attached sheet.

Examiner Note: You must sign this form unless it is an Attachment to a signed Office action.

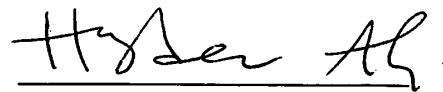

Examiner's signature, if required

Summary of Record of Interview Requirements

Manual of Patent Examining Procedure (MPEP), Section 713.04, Substance of Interview Must be Made of Record

A complete written statement as to the substance of any face-to-face, video conference, or telephone interview with regard to an application must be made of record in the application whether or not an agreement with the examiner was reached at the interview.

Title 37 Code of Federal Regulations (CFR) § 1.133 Interviews Paragraph (b)

In every instance where reconsideration is requested in view of an interview with an examiner, a complete written statement of the reasons presented at the interview as warranting favorable action must be filed by the applicant. An interview does not remove the necessity for reply to Office action as specified in §§ 1.111, 1.135. (35 U.S.C. 132)

37 CFR §1.2 Business to be transacted in writing.

All business with the Patent or Trademark Office should be transacted in writing. The personal attendance of applicants or their attorneys or agents at the Patent and Trademark Office is unnecessary. The action of the Patent and Trademark Office will be based exclusively on the written record in the Office. No attention will be paid to any alleged oral promise, stipulation, or understanding in relation to which there is disagreement or doubt.

The action of the Patent and Trademark Office cannot be based exclusively on the written record in the Office if that record is itself incomplete through the failure to record the substance of interviews.

It is the responsibility of the applicant or the attorney or agent to make the substance of an interview of record in the application file, unless the examiner indicates he or she will do so. It is the examiner's responsibility to see that such a record is made and to correct material inaccuracies which bear directly on the question of patentability.

Examiners must complete an Interview Summary Form for each interview held where a matter of substance has been discussed during the interview by checking the appropriate boxes and filling in the blanks. Discussions regarding only procedural matters, directed solely to restriction requirements for which interview recordation is otherwise provided for in Section 812.01 of the Manual of Patent Examining Procedure, or pointing out typographical errors or unreadable script in Office actions or the like, are excluded from the interview recordation procedures below. Where the substance of an interview is completely recorded in an Examiners Amendment, no separate Interview Summary Record is required.

The Interview Summary Form shall be given an appropriate Paper No., placed in the right hand portion of the file, and listed on the "Contents" section of the file wrapper. In a personal interview, a duplicate of the Form is given to the applicant (or attorney or agent) at the conclusion of the interview. In the case of a telephone or video-conference interview, the copy is mailed to the applicant's correspondence address either with or prior to the next official communication. If additional correspondence from the examiner is not likely before an allowance or if other circumstances dictate, the Form should be mailed promptly after the interview rather than with the next official communication.

The Form provides for recordation of the following information:

- Application Number (Series Code and Serial Number)
- Name of applicant
- Name of examiner
- Date of interview
- Type of interview (telephonic, video-conference, or personal)
- Name of participant(s) (applicant, attorney or agent, examiner, other PTO personnel, etc.)
- An indication whether or not an exhibit was shown or a demonstration conducted
- An identification of the specific prior art discussed
- An indication whether an agreement was reached and if so, a description of the general nature of the agreement (may be by attachment of a copy of amendments or claims agreed as being allowable). Note: Agreement as to allowability is tentative and does not restrict further action by the examiner to the contrary.
- The signature of the examiner who conducted the interview (if Form is not an attachment to a signed Office action)

It is desirable that the examiner orally remind the applicant of his or her obligation to record the substance of the interview of each case. It should be noted, however, that the Interview Summary Form will not normally be considered a complete and proper recordation of the interview unless it includes, or is supplemented by the applicant or the examiner to include, all of the applicable items required below concerning the substance of the interview.

A complete and proper recordation of the substance of any interview should include at least the following applicable items:

- 1) A brief description of the nature of any exhibit shown or any demonstration conducted,
- 2) an identification of the claims discussed,
- 3) an identification of the specific prior art discussed,
- 4) an identification of the principal proposed amendments of a substantive nature discussed, unless these are already described on the Interview Summary Form completed by the Examiner,
- 5) a brief identification of the general thrust of the principal arguments presented to the examiner,
(The identification of arguments need not be lengthy or elaborate. A verbatim or highly detailed description of the arguments is not required. The identification of the arguments is sufficient if the general nature or thrust of the principal arguments made to the examiner can be understood in the context of the application file. Of course, the applicant may desire to emphasize and fully describe those arguments which he or she feels were or might be persuasive to the examiner.)
- 6) a general indication of any other pertinent matters discussed, and
- 7) if appropriate, the general results or outcome of the interview unless already described in the Interview Summary Form completed by the examiner.

Examiners are expected to carefully review the applicant's record of the substance of an interview. If the record is not complete and accurate, the examiner will give the applicant an extendable one month time period to correct the record.

Examiner to Check for Accuracy

If the claims are allowable for other reasons of record, the examiner should send a letter setting forth the examiner's version of the statement attributed to him or her. If the record is complete and accurate, the examiner should place the indication, "Interview Record OK" on the paper recording the substance of the interview along with the date and the examiner's initials.

RECEIVED
CENTRAL FAX CENTER

NOV 30 2006

Attorney Docket No: 0492611-0598

IN THE UNITED STATES PATENT AND TRADEMARK OFFICE

Applicant: Cohn, et al. Examiner: Hyder Ali
Serial No.: 10/991,774 Art Unit: 3747
Filing Date: November 18, 2004

Title: **FUEL MANAGEMENT SYSTEM FOR VARIABLE ETHANOL
OCTANE ENHANCEMENT OF GASOLINE ENGINES**

Commissioner for Patents
P.O. Box 1450
Alexandria, VA 22313-1450

Sir:

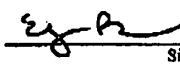
Certificate of Facsimile Transmission	
I certify that this correspondence is being transmitted via facsimile to (mail stop if applicable) Commissioner for Patents, P.O. Box 1450, Alexandria, VA 22313-1450, via facsimile no. 571-273-8300	
November 30, 2006 Date	 Signature
Elizabeth Burke Typed or Printed Name of person signing certificate	

AMENDMENT AFTER FINAL ACTION

In response to the Office Action mailed September 27, 2006 finally rejecting the pending claims, it is requested that this amendment be entered and the application allowed:

Amendments to the Claims are reflected in the listing of claims that begins on page 2 of this paper.

Remarks begin on page 7 of this paper.

*Do not enter
HA
12/12/06*

Page 1 of 8

4149358v1

Index of Claims



Application/Control No.

10/991,774

Examiner

HYDER ALI

Applicant(s)/Patent under Reexamination

COHN ET AL.

Art Unit

3747

✓	Rejected
∥	Allowed

-	(Through numeral) Cancelled
+	Restricted

N	Non-Elected
I	Interference

A	Appeal
O	Objected

Claim		Date	
Final	Original		
	1	4/18/08	9/19/08
	2		
	3		
	4		
	5		
	6		
	7		
	8		
	9		
	10		
	11		
	12		
	13		
	14		
	15		
	16		
	17		
	18		
	19		
	20		
	21		
	22		
	23		
	24		
	25		
	26		
	27		
	28		
	29		
	30		
	31		
	32		
	33		
	34		
	35		
	36		
	37		
	38		
	39		
	40		
	41		
	42		
	43		
	44		
	45		
	46		
	47		
	48		
	49		
	50		

Claim		Date	
Final	Original		
	51	7/18/08	9/19/08
	52		
	53		
	54		
	55		
	56		
	57		
	58		
	59		
	60		
	61		
	62		
	63		
	64		
	65		
	66		
	67		
	68		
	69		
	70		
	71		
	72		
	73		
	74		
	75		
	76		
	77		
	78		
	79		
	80		
	81		
	82		
	83		
	84		
	85		
	86		
	87		
	88		
	89		
	90		
	91		
	92		
	93		
	94		
	95		
	96		
	97		
	98		
	99		
	100		

Claim		Date	
Final	Original		
	101		
	102		
	103		
	104		
	105		
	106		
	107		
	108		
	109		
	110		
	111		
	112		
	113		
	114		
	115		
	116		
	117		
	118		
	119		
	120		
	121		
	122		
	123		
	124		
	125		
	126		
	127		
	128		
	129		
	130		
	131		
	132		
	133		
	134		
	135		
	136		
	137		
	138		
	139		
	140		
	141		
	142		
	143		
	144		
	145		
	146		
	147		
	148		
	149		
	150		

Search Notes



Application/Control No.

10/991,774

Examiner

HYDER ALI

Applicant(s)/Patent under Reexamination

COHN ET AL.

Art Unit

3747

SEARCHED

Class	Subclass	Date	Examiner
123	1A	4/17/2006	HA
123	198A	4/17/2006	HA
123	525	4/17/2006	HA
123	25A	4/17/2006	HA
123	25J	4/17/2006	HA
123	435	9/19/06	HA
123	575	9/19/06	HA
123	406.29	9/19/06	HA
123	406.47	9/19/06	HA
UPDATED		9/19/06	HA
UPDATED		12/12/06	HA

**SEARCH NOTES
(INCLUDING SEARCH STRATEGY)**

	DATE	EXMR
SEARCHED EAST SEE EAST SEARCH PRINT OUT.	4/17/2006	HA

INTERFERENCE SEARCHED

Class	Subclass	Date	Examiner



UNITED STATES PATENT AND TRADEMARK OFFICE

UNITED STATES DEPARTMENT OF COMMERCE
 United States Patent and Trademark Office
 Address COMMISSIONER FOR PATENTS
 P.O. Box 1450
 Alexandria, Virginia 22313-1450
 www.uspto.gov



Bib Data Sheet

CONFIRMATION NO. 8282

SERIAL NUMBER 10/991,774	FILING DATE 11/18/2004 RULE	CLASS 123	GROUP ART UNIT 3747	ATTORNEY DOCKET NO. 0492611-0598	
APPLICANTS Daniel R. Cohn, Chestnut Hill, MA; Leslie Bromberg, Sharon, MA; John B. Heywood, Newton, MA; ** CONTINUING DATA ***** NONE ** FOREIGN APPLICATIONS ***** NONE IF REQUIRED, FOREIGN FILING LICENSE GRANTED ** SMALL ENTITY ** ** 03/01/2005					
Foreign Priority claimed 35 USC 119 (e-d) conditions met	<input type="checkbox"/> yes <input checked="" type="checkbox"/> no <input type="checkbox"/> yes <input checked="" type="checkbox"/> no Met after Allowance Verified and Acknowledged Examiner's Signature: <i>H. A. A.</i> Initials: <i>H.A.</i>	STATE OR COUNTRY MA	SHEETS DRAWING 3	TOTAL CLAIMS 56	INDEPENDENT CLAIMS 2
ADDRESS 24280 CHOATE, HALL & STEWART LLP TWO INTERNATIONAL PLACE BOSTON, MA 02110					
TITLE Fuel management system for variable ethanol octane enhancement of gasoline engines					
FILING FEE RECEIVED 1312	FEES: Authority has been given in Paper No. _____ to charge/credit DEPOSIT ACCOUNT No. _____ for following:		<input type="checkbox"/> All Fees <input type="checkbox"/> 1.16 Fees (Filing) <input type="checkbox"/> 1.17 Fees (Processing Ext. of time) <input type="checkbox"/> 1.18 Fees (Issue) <input type="checkbox"/> Other _____ <input type="checkbox"/> Credit		

<http://neo:8000/PrexServlet/PrexAction?serviceName=BibDataSheet&Action=display&brow...> 4/17/06

**REQUEST FOR CONTINUED EXAMINATION(RCE)TRANSMITTAL
(Submitted Only via EFS-Web)**

Application Number	10/991,774	Filing Date	2004-11-18	Docket Number (if applicable)	0492611-0598	Art Unit	3747
First Named Inventor	Daniel R. Cohn			Examiner Name	HYDER ALI		

This is a Request for Continued Examination (RCE) under 37 CFR 1.114 of the above-identified application.

Request for Continued Examination (RCE) practice under 37 CFR 1.114 does not apply to any utility or plant application filed prior to June 8, 1995, or to any design application. The Instruction Sheet for this form is located at WWW.USPTO.GOV

SUBMISSION REQUIRED UNDER 37 CFR 1.114

Note: If the RCE is proper, any previously filed unentered amendments and amendments enclosed with the RCE will be entered in the order in which they were filed unless applicant instructs otherwise. If applicant does not wish to have any previously filed unentered amendment(s) entered, applicant must request non-entry of such amendment(s).

Previously submitted. If a final Office action is outstanding, any amendments filed after the final Office action may be considered as a submission even if this box is not checked.

Consider the arguments in the Appeal Brief or Reply Brief previously filed on 2006-11-30

Other _____

Enclosed

Amendment/Reply

Information Disclosure Statement (IDS)

Affidavit(s)/ Declaration(s)

Other _____

MISCELLANEOUS

Suspension of action on the above-identified application is requested under 37 CFR 1.103(c) for a period of months _____
(Period of suspension shall not exceed 3 months; Fee under 37 CFR 1.17(i) required)

Other _____

FEES

The RCE fee under 37 CFR 1.17(e) is required by 37 CFR 1.114 when the RCE is filed.

The Director is hereby authorized to charge any underpayment of fees, or credit any overpayments, to Deposit Account No 031721

SIGNATURE OF APPLICANT, ATTORNEY, OR AGENT REQUIRED

Patent Practitioner Signature

Applicant Signature

Under the Paperwork Reduction Act of 1995, no persons are required to respond to a collection of information unless it contains a valid OMB control number.

Signature of Registered U.S. Patent Practitioner			
Signature	/SamPasternack/	Date (YYYY-MM-DD)	2007-03-09
Name	Sam Pasternack	Registration Number	29576

This collection of information is required by 37 CFR 1.114. The information is required to obtain or retain a benefit by the public which is to file (and by the USPTO to process) an application. Confidentiality is governed by 35 U.S.C. 122 and 37 CFR 1.11 and 1.14. This collection is estimated to take 12 minutes to complete, including gathering, preparing, and submitting the completed application form to the USPTO. Time will vary depending upon the individual case. Any comments on the amount of time you require to complete this form and/or suggestions for reducing this burden, should be sent to the Chief Information Officer, U.S. Patent and Trademark Office, U.S. Department of Commerce, P.O. Box 1450, Alexandria, VA 22313-1450.

If you need assistance in completing the form, call 1-800-PTO-9199 and select option 2.

Privacy Act Statement

The Privacy Act of 1974 (P.L. 93-579) requires that you be given certain information in connection with your submission of the attached form related to a patent application or patent. Accordingly, pursuant to the requirements of the Act, please be advised that: (1) the general authority for the collection of this information is 35 U.S.C. 2(b)(2); (2) furnishing of the information solicited is voluntary; and (3) the principal purpose for which the information is used by the U.S. Patent and Trademark Office is to process and/or examine your submission related to a patent application or patent. If you do not furnish the requested information, the U.S. Patent and Trademark Office may not be able to process and/or examine your submission, which may result in termination of proceedings or abandonment of the application or expiration of the patent.

The information provided by you in this form will be subject to the following routine uses:

1. The information on this form will be treated confidentially to the extent allowed under the Freedom of Information Act (5 U.S.C. 552) and the Privacy Act (5 U.S.C. 552a). Records from this system of records may be disclosed to the Department of Justice to determine whether the Freedom of Information Act requires disclosure of these records.
2. A record from this system of records may be disclosed, as a routine use, in the course of presenting evidence to a court, magistrate, or administrative tribunal, including disclosures to opposing counsel in the course of settlement negotiations.
3. A record in this system of records may be disclosed, as a routine use, to a Member of Congress submitting a request involving an individual, to whom the record pertains, when the individual has requested assistance from the Member with respect to the subject matter of the record.
4. A record in this system of records may be disclosed, as a routine use, to a contractor of the Agency having need for the information in order to perform a contract. Recipients of information shall be required to comply with the requirements of the Privacy Act of 1974, as amended, pursuant to 5 U.S.C. 552a(m).
5. A record related to an International Application filed under the Patent Cooperation Treaty in this system of records may be disclosed, as a routine use, to the International Bureau of the World Intellectual Property Organization, pursuant to the Patent Cooperation Treaty.
6. A record in this system of records may be disclosed, as a routine use, to another federal agency for purposes of National Security review (35 U.S.C. 181) and for review pursuant to the Atomic Energy Act (42 U.S.C. 218(c)).
7. A record from this system of records may be disclosed, as a routine use, to the Administrator, General Services, or his/her designee, during an inspection of records conducted by GSA as part of that agency's responsibility to recommend improvements in records management practices and programs, under authority of 44 U.S.C. 2904 and 2906. Such disclosure shall be made in accordance with the GSA regulations governing inspection of records for this purpose, and any other relevant (i.e., GSA or Commerce) directive. Such disclosure shall not be used to make determinations about individuals.
8. A record from this system of records may be disclosed, as a routine use, to the public after either publication of the application pursuant to 35 U.S.C. 122(b) or issuance of a patent pursuant to 35 U.S.C. 151. Further, a record may be disclosed, subject to the limitations of 37 CFR 1.14, as a routine use, to the public if the record was filed in an application which became abandoned or in which the proceedings were terminated and which application is referenced by either a published application, an application open to public inspections or an issued patent.
9. A record from this system of records may be disclosed, as a routine use, to a Federal, State, or local law enforcement agency, if the USPTO becomes aware of a violation or potential violation of law or regulation.

Electronic Patent Application Fee Transmittal

Application Number:	10991774			
Filing Date:	18-Nov-2004			
Title of Invention:	Fuel management system for variable ethanol octane enhancehment of gasoline engines			
First Named Inventor/Applicant Name:	Daniel R. Cohn			
Filer:	Sam Pasternack/Elizabeth Burke			
Attorney Docket Number:	0492611-0598			
Filed as Small Entity				
Utility Filing Fees				
Description	Fee Code	Quantity	Amount	Sub-Total in USD(\$)
Basic Filing:				
Pages:				
Claims:				
Miscellaneous-Filing:				
Petition:				
Patent-Appeals-and-Interference:				
Post-Allowance-and-Post-Issuance:				
Extension-of-Time:				

Description	Fee Code	Quantity	Amount	Sub-Total in USD(\$)
Miscellaneous:				
Request for continued examination	2801	1	395	395
Total in USD (\$)				395

Electronic Acknowledgement Receipt

EFS ID:	1579892
Application Number:	10991774
International Application Number:	
Confirmation Number:	8282
Title of Invention:	Fuel management system for variable ethanol octane enhancehment of gasoline engines
First Named Inventor/Applicant Name:	Daniel R. Cohn
Customer Number:	24280
Filer:	Sam Pasternack/Elizabeth Burke
Filer Authorized By:	Sam Pasternack
Attorney Docket Number:	0492611-0598
Receipt Date:	09-MAR-2007
Filing Date:	18-NOV-2004
Time Stamp:	15:24:39
Application Type:	Utility

Payment information:

Submitted with Payment	yes
Payment was successfully received in RAM	\$395
RAM confirmation Number	207
Deposit Account	

File Listing:

Document Number	Document Description	File Name	File Size(Bytes)	Multi Part /.zip	Pages (if appl.)
-----------------	----------------------	-----------	------------------	------------------	------------------

1	Request for Continued Examination (RCE)	MIT0598RCE.pdf	644650	no	3
Warnings:					
Information:					
2	Fee Worksheet (PTO-06)	fee-info.pdf	8204	no	2
Warnings:					
Information:					
Total Files Size (in bytes):			652854		
<p>This Acknowledgement Receipt evidences receipt on the noted date by the USPTO of the indicated documents, characterized by the applicant, and including page counts, where applicable. It serves as evidence of receipt similar to a Post Card, as described in MPEP 503.</p> <p><u>New Applications Under 35 U.S.C. 111</u> If a new application is being filed and the application includes the necessary components for a filing date (see 37 CFR 1.53(b)-(d) and MPEP 506), a Filing Receipt (37 CFR 1.54) will be issued in due course and the date shown on this Acknowledgement Receipt will establish the filing date of the application.</p> <p><u>National Stage of an International Application under 35 U.S.C. 371</u> If a timely submission to enter the national stage of an international application is compliant with the conditions of 35 U.S.C. 371 and other applicable requirements a Form PCT/DO/EO/903 indicating acceptance of the application as a national stage submission under 35 U.S.C. 371 will be issued in addition to the Filing Receipt, in due course.</p> <p><u>New International Application Filed with the USPTO as a Receiving Office</u> If a new international application is being filed and the international application includes the necessary components for an international filing date (see PCT Article 11 and MPEP 1810), a Notification of the International Application Number and of the International Filing Date (Form PCT/RO/105) will be issued in due course, subject to prescriptions concerning national security, and the date shown on this Acknowledgement Receipt will establish the international filing date of the application.</p>					

Document code: WFEE

United States Patent and Trademark Office
Sales Receipt for Accounting Date: 03/15/2007

LFULTON SALE #00000003 Mailroom Dt: 03/09/2007 031721 10991774
01 FC : 2201 100.00 DA

Document code: WFEE

United States Patent and Trademark Office
Sales Receipt for Accounting Date: 03/15/2007

LFULTON SALE #00000002 Mailroom Dt: 03/09/2007 031721 10991774
01 FC : 2253 510.00 DA

RECEIVED
CENTRAL FAX CENTER

NOV 30 2006

Attorney Docket No: 0492611-0598

IN THE UNITED STATES PATENT AND TRADEMARK OFFICE

Applicant: Cohn, et al. Examiner: Hyder Ali
Serial No.: 10/991,774 Art Unit: 3747
Filing Date: November 18, 2004

Title: **FUEL MANAGEMENT SYSTEM FOR VARIABLE ETHANOL
OCTANE ENHANCEMENT OF GASOLINE ENGINES**

*J.P.
11/14/06
Entered by RCE*

Commissioner for Patents
P.O. Box 1450
Alexandria, VA 22313-1450

Sir:

Certificate of Facsimile Transmission	
I certify that this correspondence is being transmitted via facsimile to (mail stop if applicable) Commissioner for Patents, P.O. Box 1450, Alexandria, VA 22313-1450, via facsimile no. 571-273-8300	
November 30, 2006 Date	<i>[Signature]</i> Signature
Elizabeth Burke Typed or Printed Name of person signing certificate	

AMENDMENT AFTER FINAL ACTION

In response to the Office Action mailed September 27, 2006 finally rejecting the pending claims, it is requested that this amendment be entered and the application allowed:

Amendments to the Claims are reflected in the listing of claims that begins on page 2 of this paper.

Remarks begin on page 7 of this paper.

PATENT APPLICATION FEE DETERMINATION RECORD
Effective October 1, 2003

Application or Docket Number

1d/991774

3/9/7

CLAIMS AS FILED - PART I

	(Column 1)	(Column 2)
TOTAL CLAIMS		
FOR <i>2CE</i>	NUMBER FILED	NUMBER EXTRA
TOTAL CHARGEABLE CLAIMS	4 minus 20 =	0
INDEPENDENT CLAIMS	4 minus 3 =	1
MULTIPLE DEPENDENT CLAIM PRESENT <input type="checkbox"/>		

~~FEE 575.00~~
If the difference in column 1 is less than zero, enter "0" in column 2.

CLAIMS AS AMENDED - PART II

	(Column 1)	(Column 2)	(Column 3)
AMENDMENT A	CLAIMS REMAINING AFTER AMENDMENT	HIGHEST NUMBER PREVIOUSLY PAID FOR	PRESENT EXTRA
	Total	Minus	** =
	Independent	Minus	*** =
FIRST PRESENTATION OF MULTIPLE DEPENDENT CLAIM <input type="checkbox"/>			

	(Column 1)	(Column 2)	(Column 3)
AMENDMENT B	CLAIMS REMAINING AFTER AMENDMENT	HIGHEST NUMBER PREVIOUSLY PAID FOR	PRESENT EXTRA
	Total	Minus	** =
	Independent	Minus	*** =
FIRST PRESENTATION OF MULTIPLE DEPENDENT CLAIM <input type="checkbox"/>			

	(Column 1)	(Column 2)	(Column 3)
AMENDMENT C	CLAIMS REMAINING AFTER AMENDMENT	HIGHEST NUMBER PREVIOUSLY PAID FOR	PRESENT EXTRA
	Total	Minus	** =
	Independent	Minus	*** =
FIRST PRESENTATION OF MULTIPLE DEPENDENT CLAIM <input type="checkbox"/>			

- * If the entry in column 1 is less than the entry in column 2, write "0" in column 3.
 - ** If the "Highest Number Previously Paid For" IN THIS SPACE is less than 20, enter "20."
 - *** If the "Highest Number Previously Paid For" IN THIS SPACE is less than 3, enter "3."
- The "Highest Number Previously Paid For" (Total or Independent) is the highest number found in the appropriate box in column 1.

SMALL ENTITY TYPE

OR OTHER THAN SMALL ENTITY

RATE	FEE
BASIC FEE	395.00
X\$ 9=	
X43=	100.00
+145=	
TOTAL	495.00

RATE	FEE
BASIC FEE	770.00
X\$18=	
X86=	
+290=	
TOTAL	

SMALL ENTITY

OR OTHER THAN SMALL ENTITY

RATE	ADDITIONAL FEE
X\$ 9=	
X43=	
+145=	
TOTAL ADDIT. FEE	

RATE	ADDITIONAL FEE
X\$18=	
X86=	
+290=	
TOTAL ADDIT. FEE	

RATE	ADDITIONAL FEE
X\$ 9=	
X43=	
+145=	
TOTAL ADDIT. FEE	

RATE	ADDITIONAL FEE
X\$18=	
X86=	
+290=	
TOTAL ADDIT. FEE	

RATE	ADDITIONAL FEE
X\$ 9=	
X43=	
+145=	
TOTAL ADDIT. FEE	

RATE	ADDITIONAL FEE
X\$18=	
X86=	
+290=	
TOTAL ADDIT. FEE	



UNITED STATES PATENT AND TRADEMARK OFFICE

UNITED STATES DEPARTMENT OF COMMERCE
United States Patent and Trademark Office
Address: COMMISSIONER FOR PATENTS
P.O. Box 1450
Alexandria, Virginia 22313-1450
www.uspto.gov

APPLICATION NO.	FILING DATE	FIRST NAMED INVENTOR	ATTORNEY DOCKET NO.	CONFIRMATION NO.
10/991,774	11/18/2004	Daniel R. Cohn	0492611-0598	8282

24280 7590 05/25/2007
CHOATE, HALL & STEWART LLP
TWO INTERNATIONAL PLACE
BOSTON, MA 02110

EXAMINER

ALI, HYDER

ART UNIT	PAPER NUMBER
----------	--------------

3747

MAIL DATE	DELIVERY MODE
-----------	---------------

05/25/2007

PAPER

Please find below and/or attached an Office communication concerning this application or proceeding.

The time period for reply, if any, is set in the attached communication.

Office Action Summary	Application No. 10/991,774	Applicant(s) COHN ET AL.	
	Examiner HYDER ALI	Art Unit 3747	

-- The MAILING DATE of this communication appears on the cover sheet with the correspondence address --

Period for Reply

A SHORTENED STATUTORY PERIOD FOR REPLY IS SET TO EXPIRE 3 MONTH(S) OR THIRTY (30) DAYS, WHICHEVER IS LONGER, FROM THE MAILING DATE OF THIS COMMUNICATION.

- Extensions of time may be available under the provisions of 37 CFR 1.136(a). In no event, however, may a reply be timely filed after SIX (6) MONTHS from the mailing date of this communication.
- If NO period for reply is specified above, the maximum statutory period will apply and will expire SIX (6) MONTHS from the mailing date of this communication.
- Failure to reply within the set or extended period for reply will, by statute, cause the application to become ABANDONED (35 U.S.C. § 133). Any reply received by the Office later than three months after the mailing date of this communication, even if timely filed, may reduce any earned patent term adjustment. See 37 CFR 1.704(b).

Status

- 1) Responsive to communication(s) filed on 09 March 2007.
- 2a) This action is **FINAL**. 2b) This action is non-final.
- 3) Since this application is in condition for allowance except for formal matters, prosecution as to the merits is closed in accordance with the practice under *Ex parte Quayle*, 1935 C.D. 11, 453 O.G. 213.

Disposition of Claims

- 4) Claim(s) 57-60 is/are pending in the application.
4a) Of the above claim(s) _____ is/are withdrawn from consideration.
- 5) Claim(s) 59 and 60 is/are allowed.
- 6) Claim(s) 57 and 58 is/are rejected.
- 7) Claim(s) _____ is/are objected to.
- 8) Claim(s) _____ are subject to restriction and/or election requirement.

Application Papers

- 9) The specification is objected to by the Examiner.
- 10) The drawing(s) filed on 18 November 2004 is/are: a) accepted or b) objected to by the Examiner.
Applicant may not request that any objection to the drawing(s) be held in abeyance. See 37 CFR 1.85(a).
Replacement drawing sheet(s) including the correction is required if the drawing(s) is objected to. See 37 CFR 1.121(d).
- 11) The oath or declaration is objected to by the Examiner. Note the attached Office Action or form PTO-152.

Priority under 35 U.S.C. § 119

- 12) Acknowledgment is made of a claim for foreign priority under 35 U.S.C. § 119(a)-(d) or (f).
a) All b) Some * c) None of:
1. Certified copies of the priority documents have been received.
2. Certified copies of the priority documents have been received in Application No. _____.
3. Copies of the certified copies of the priority documents have been received in this National Stage application from the International Bureau (PCT Rule 17.2(a)).

* See the attached detailed Office action for a list of the certified copies not received.

Attachment(s)

- | | |
|--|---|
| 1) <input type="checkbox"/> Notice of References Cited (PTO-892) | 4) <input type="checkbox"/> Interview Summary (PTO-413)
Paper No(s)/Mail Date. _____ |
| 2) <input type="checkbox"/> Notice of Draftsperson's Patent Drawing Review (PTO-948) | 5) <input type="checkbox"/> Notice of Informal Patent Application |
| 3) <input type="checkbox"/> Information Disclosure Statement(s) (PTO/SB/08)
Paper No(s)/Mail Date _____ | 6) <input type="checkbox"/> Other: _____ |

DETAILED ACTION

Inventorship

This application currently names joint inventors. In considering patentability of the claims under 35 U.S.C. 103(a), the examiner presumes that the subject matter of the various claims was commonly owned at the time any inventions covered therein were made absent any evidence to the contrary. Applicant is advised of the obligation under 37 CFR 1.56 to point out the inventor and invention dates of each claim that was not commonly owned at the time a later invention was made in order for the examiner to consider the applicability of 35 U.S.C. 103(c) and potential 35 U.S.C. 102(e), (f) or (g) prior art under 35 U.S.C. 103(a).

Oath/Declaration Objection

Oath/Declaration is objected to because the oath/declaration duty to disclose statement is improper.

The oath or declaration is defective. A new oath or declaration in compliance with 37 CFR 1.67(a) identifying this application by application number and filing date is required. See MPEP §§ 602.01 and 602.02.

The oath or declaration is defective because:
It does not state that the person making the oath or declaration acknowledges the duty to disclose to the Office all information known to the person to be material to patentability as defined in 37 CFR 1.56.

Double Patenting

The nonstatutory double patenting rejection is based on a judicially created doctrine grounded in public policy (a policy reflected in the statute) so as to prevent the unjustified or improper timewise extension of the "right to exclude" granted by a patent

and to prevent possible harassment by multiple assignees. A nonstatutory obviousness-type double patenting rejection is appropriate where the conflicting claims are not identical, but at least one examined application claim is not patentably distinct from the reference claim(s) because the examined application claim is either anticipated by, or would have been obvious over, the reference claim(s). See, e.g., *In re Berg*, 140 F.3d 1428, 46 USPQ2d 1226 (Fed. Cir. 1998); *In re Goodman*, 11 F.3d 1046, 29 USPQ2d 2010 (Fed. Cir. 1993); *In re Longi*, 759 F.2d 887, 225 USPQ 645 (Fed. Cir. 1985); *In re Van Ornum*, 686 F.2d 937, 214 USPQ 761 (CCPA 1982); *In re Vogel*, 422 F.2d 438, 164 USPQ 619 (CCPA 1970); and *In re Thorington*, 418 F.2d 528, 163 USPQ 644 (CCPA 1969).

A timely filed terminal disclaimer in compliance with 37 CFR 1.321(c) or 1.321(d) may be used to overcome an actual or provisional rejection based on a nonstatutory double patenting ground provided the conflicting application or patent either is shown to be commonly owned with this application, or claims an invention made as a result of activities undertaken within the scope of a joint research agreement.

Effective January 1, 1994, a registered attorney or agent of record may sign a terminal disclaimer. A terminal disclaimer signed by the assignee must fully comply with 37 CFR 3.73(b).

Claims 57 and 58 are provisionally rejected on the ground of nonstatutory obviousness-type double patenting as being unpatentable over claims 77-85 of copending Application No. 11/100026. Although the conflicting claims are not identical, they are not patentably distinct from each other because they have the same structure and scope.

This is a provisional obviousness-type double patenting rejection because the conflicting claims have not in fact been patented.

Allowable Subject Matter

Claims 59 and 60 are allowed.

Conclusion

Any inquiry concerning this communication or earlier communications from the examiner should be directed to HYDER ALI whose telephone number is (571) 272-4836. The examiner can normally be reached on M-F (8:30-5:00).

If attempts to reach the examiner by telephone are unsuccessful, the examiner's supervisor, Stephen Kirk Cronin can be reached on (571) 272-4536. The fax phone number for the organization where this application or proceeding is assigned is 571-273-8300.

Information regarding the status of an application may be obtained from the Patent Application Information Retrieval (PAIR) system. Status information for published applications may be obtained from either Private PAIR or Public PAIR. Status information for unpublished applications is available through Private PAIR only. For more information about the PAIR system, see <http://pair-direct.uspto.gov>. Should you have questions on access to the Private PAIR system, contact the Electronic Business Center (EBC) at 866-217-9197 (toll-free). If you would like assistance from a USPTO Customer Service Representative or access to the automated information system, call 800-786-9199 (IN USA OR CANADA) or 571-272-1000.

Hyler Al.

ha

Tony M. Argenbright
Tony M. Argenbright
Primary Examiner
Art Unit 3747



UNITED STATES PATENT AND TRADEMARK OFFICE

UNITED STATES DEPARTMENT OF COMMERCE
 United States Patent and Trademark Office
 Address: COMMISSIONER FOR PATENTS
 P.O. Box 1450
 Alexandria, Virginia 22313-1450
 www.uspto.gov



Bib Data Sheet

CONFIRMATION NO. 8282

SERIAL NUMBER 10/991,774	FILING OR 371(c) DATE 11/18/2004	CLASS 123	GROUP ART UNIT 3747	ATTORNEY DOCKET NO. 0492611-0598
RULE				

APPLICANTS
 Daniel R. Cohn, Chestnut Hill, MA;
 Leslie Bromberg, Sharon, MA;
 John B. Heywood, Newton, MA;

** CONTINUING DATA ***** NONE

** FOREIGN APPLICATIONS ***** NONE

IF REQUIRED, FOREIGN FILING LICENSE GRANTED SMALL ENTITY ****
 ** 03/01/2005

Foreign Priority claimed <input type="checkbox"/> yes <input checked="" type="checkbox"/> no	STATE OR COUNTRY MA	SHEETS DRAWING 3	TOTAL CLAIMS 56	INDEPENDENT CLAIMS 2
35 USC 119 (a-d) conditions met <input type="checkbox"/> yes <input checked="" type="checkbox"/> no <input type="checkbox"/> Met after Allowance				
Verified and Acknowledged	<i>Hyde M.</i> Examiner's Signature	<i>HA</i> Initials		

ADDRESS
24280

TITLE
Fuel management system for variable ethanol octane enhancehment of gasoline engines

FILING FEE RECEIVED 1412	FEES: Authority has been given in Paper No. _____ to charge/credit DEPOSIT ACCOUNT No. _____ for following:	<input type="checkbox"/> All Fees
		<input type="checkbox"/> 1.16 Fees (Filing)
		<input type="checkbox"/> 1.17 Fees (Processing Ext. of time)
		<input type="checkbox"/> 1.18 Fees (Issue)
		<input type="checkbox"/> Other _____
		<input type="checkbox"/> Credit

RECEIVED
CENTRAL FAX CENTER
NOV 30 2006

Attorney Docket No: 0492611-0598

IN THE UNITED STATES PATENT AND TRADEMARK OFFICE

Applicant: Cohn, et al. Examiner: Hyder Ali
Serial No.: 10/991,774 Art Unit: 3747
Filing Date: November 18, 2004

Title: **FUEL MANAGEMENT SYSTEM FOR VARIABLE ETHANOL
OCTANE ENHANCEMENT OF GASOLINE ENGINES**

*J.F.
2/14/07
Entered by RCE*

Commissioner for Patents
P.O. Box 1450
Alexandria, VA 22313-1450

Sir:

Certificate of Facsimile Transmission	
I certify that this correspondence is being transmitted via facsimile to (mail stop if applicable) Commissioner for Patents, P.O. Box 1450, Alexandria, VA 22313-1450, via facsimile no. 571-273-4300	
November 18, 2006 Date	<i>[Signature]</i> Signature
Eileenbeth Burke Typed or Printed Name of person signing certificate	

AMENDMENT AFTER FINAL ACTION

In response to the Office Action mailed September 27, 2006 finally rejecting the pending claims, it is requested that this amendment be entered and the application allowed:

Amendments to the Claims are reflected in the listing of claims that begins on page 2 of this paper.

Remarks begin on page 7 of this paper.

Okay to enter

HA

05/16/07

Index of Claims



Application/Control No.

10/991,774

Examiner

HYDER ALI

Applicant(s)/Patent under Reexamination

COHN ET AL.

Art Unit

3747

✓	Rejected
□	Allowed

-	(Through numeral) Canceled
+	Restricted

N	Non-Elected
I	Interference

A	Appeal
O	Objected

Claim		Date	
Final	Original		
	1		
	2		
	3		
	4		
	5		
	6		
	7		
	8		
	9		
	10		
	11		
	12		
	13		
	14		
	15		
	16		
	17		
	18		
	19		
	20		
	21		
	22		
	23		
	24		
	25		
	26		
	27		
	28		
	29		
	30		
	31		
	32		
	33		
	34		
	35		
	36		
	37		
	38		
	39		
	40		
	41		
	42		
	43		
	44		
	45		
	46		
	47		
	48		
	49		
	50		

Claim		Date	
Final	Original		
	51		
	52		
	53		
	54		
	55		
	56		
	57		
	58		
	59		
	60		
	61		
	62		
	63		
	64		
	65		
	66		
	67		
	68		
	69		
	70		
	71		
	72		
	73		
	74		
	75		
	76		
	77		
	78		
	79		
	80		
	81		
	82		
	83		
	84		
	85		
	86		
	87		
	88		
	89		
	90		
	91		
	92		
	93		
	94		
	95		
	96		
	97		
	98		
	99		
	100		

Claim		Date	
Final	Original		
	101		
	102		
	103		
	104		
	105		
	106		
	107		
	108		
	109		
	110		
	111		
	112		
	113		
	114		
	115		
	116		
	117		
	118		
	119		
	120		
	121		
	122		
	123		
	124		
	125		
	126		
	127		
	128		
	129		
	130		
	131		
	132		
	133		
	134		
	135		
	136		
	137		
	138		
	139		
	140		
	141		
	142		
	143		
	144		
	145		
	146		
	147		
	148		
	149		
	150		

Search Notes



Application/Control No.

10/991,774

Examiner

HYDER ALI

Applicant(s)/Patent under Reexamination

COHN ET AL.

Art Unit

3747

SEARCHED

Class	Subclass	Date	Examiner
123	1A	4/17/2008	HA
123	198A	4/17/2008	HA
123	525	4/17/2008	HA
123	25A	4/17/2008	HA
123	25J	4/17/2008	HA
123	435	9/19/06	HA
123	575	9/19/06	HA
123	406.29	9/19/06	HA
123	406.47	9/19/06	HA
UPDATED		9/19/06	HA
UPDATED		12/12/06	HA
UPDATED		5/16/07	HA

INTERFERENCE SEARCHED

Class	Subclass	Date	Examiner

**SEARCH NOTES
(INCLUDING SEARCH STRATEGY)**

	DATE	EXMR
SEARCHED EAST SEE EAST SEARCH PRINT OUT.	4/17/2008	HA

ATTORNEY DOCKET NO. 0492611-0598

IN THE UNITED STATES PATENT AND TRADEMARK OFFICE

Applicant: Cohn, *et al.*

Serial No.: 10/991,774

Examiner: ALI, HYDER

Filed: November 18, 2004

Art Unit: 1714

For: FUEL MANAGEMENT SYSTEM FOR VARIABLE ETHANOL OCTANE
ENHANCEMENT OF GASOLINE ENGINES

RESPONSE TO OFFICE ACTION

In response to the office action mailed May 25, 2007 please consider the following remarks:

REMARKS

Reexamination and reconsideration of the rejections are hereby requested.

Claims 57-60 are pending in this application. Claims 57 and 58 stand rejected on the ground of non-statutory obviousness-type double patentee. Claim 59 and 60 stand allowed.

Included herewith is a terminal disclaimer with respect to co-pending and co-owned application serial number 11/100,026 (now US Patent No. 7,225,787) It is submitted that this terminal disclaimer overcomes the obviousness-type double patenting rejection.

It is submitted that this application is in condition for allowance and early favorable action is requested.

Respectfully submitted,
CHOATE, HALL & STEWART LLP

/SamPasternack/
Sam Pasternack

Date: July 27, 2007

Patent Department
CHOATE, HALL & STEWART, LLP
Two International Place
Boston, MA 02110
Tel: (617) 248-5000
Fax: (617) 248-4000

TERMINAL DISCLAIMER TO OBTAIN A PROVISIONAL DOUBLE PATENTING REJECTION OVER A PENDING "REFERENCE" APPLICATION	Docket Number (Optional)
In re Application of: FUEL MANAGEMENT SYSTEM FOR VARIABLE ETHANOL OCTANE ENHANCEMENT OF GASOLINE ENGINES	
Application No.: 10/991,774	
Filed: November 18, 2004	
For: Daniel R. Cohn	
<p>The owner*, <u>Massachusetts Institute of Technology</u>, of <u>100</u> percent interest in the instant application hereby disclaims, except as provided below, the terminal part of the statutory term of any patent granted on the instant application which would extend beyond the expiration date of the full statutory term of any patent granted on pending reference Application Number <u>11/100,026</u>, filed on <u>04-06-2005</u>, as such term is defined in 35 U.S.C. 154 and 173, and as the term of any patent granted on said reference application may be shortened by any terminal disclaimer filed prior to the grant of any patent on the pending reference application. The owner hereby agrees that any patent so granted on the instant application shall be enforceable only for and during such period that it and any patent granted on the reference application are commonly owned. This agreement runs with any patent granted on the instant application and is binding upon the grantee, its successors or assigns.</p>	
<p>In making the above disclaimer, the owner does not disclaim the terminal part of any patent granted on the instant application that would extend to the expiration date of the full statutory term as defined in 35 U.S.C. 154 and 173 of any patent granted on said reference application, "as the term of any patent granted on said reference application may be shortened by any terminal disclaimer filed prior to the grant of any patent on the pending reference application," in the event that: any such patent: granted on the pending reference application: expires for failure to pay a maintenance fee, is held unenforceable, is found invalid by a court of competent jurisdiction, is statutorily disclaimed in whole or terminally disclaimed under 37 CFR 1.321, has all claims canceled by a reexamination certificate, is reissued, or is in any manner terminated prior to the expiration of its full statutory term as shortened by any terminal disclaimer filed prior to its grant.</p>	
Check either box 1 or 2 below, if appropriate.	
<p>1. <input type="checkbox"/> For submissions on behalf of a business/organization (e.g., corporation, partnership, university, government agency, etc.), the undersigned is empowered to act on behalf of the business/organization.</p>	
<p>I hereby declare that all statements made herein of my own knowledge are true and that all statements made on information and belief are believed to be true; and further that these statements were made with the knowledge that willful false statements and the like so made are punishable by fine or imprisonment, or both, under Section 1001 of Title 18 of the United States Code and that such willful false statements may jeopardize the validity of the application or any patent issued thereon.</p>	
<p>2. <input checked="" type="checkbox"/> The undersigned is an attorney or agent of record. Reg. No. <u>29576</u></p>	
<p><u>/SamPasternack/</u> Signature</p>	<p><u>07/27/2007</u> Date</p>
<p><u>Sam Pasternack</u> Typed or printed name</p>	
<p><u>617-248-5143</u> Telephone Number</p>	
<p><input checked="" type="checkbox"/> Terminal disclaimer fee under 37 CFR 1.20(d) is included.</p>	
<p>WARNING: Information on this form may become public. Credit card information should not be included on this form. Provide credit card information and authorization on PTO-2038.</p>	
<p>*Statement under 37 CFR 3.73(b) is required if terminal disclaimer is signed by the assignee (owner). Form PTO/SB/96 may be used for making this statement. See MPEP § 324.</p>	

This collection of information is required by 37 CFR 1.321. The information is required to obtain or retain a benefit by the public which is to file (and by the USPTO to process) an application. Confidentiality is governed by 35 U.S.C. 122 and 37 CFR 1.11 and 1.14. This collection is estimated to take 12 minutes to complete, including gathering, preparing, and submitting the completed application form to the USPTO. Time will vary depending upon the individual case. Any comments on the amount of time you require to complete this form and/or suggestions for reducing this burden, should be sent to the Chief Information Officer, U.S. Patent and Trademark Office, U.S. Department of Commerce, P.O. Box 1450, Alexandria, VA 22313-1450. DO NOT SEND FEES OR COMPLETED FORMS TO THIS ADDRESS. SEND TO: Commissioner for Patents, P.O. Box 1450, Alexandria, VA 22313-1450.

If you need assistance in completing the form, call 1-800-PTO-9199 and select option 2.

Privacy Act Statement

The **Privacy Act of 1974 (P.L. 93-579)** requires that you be given certain information in connection with your submission of the attached form related to a patent application or patent. Accordingly, pursuant to the requirements of the Act, please be advised that: (1) the general authority for the collection of this information is 35 U.S.C. 2(b)(2); (2) furnishing of the information solicited is voluntary; and (3) the principal purpose for which the information is used by the U.S. Patent and Trademark Office is to process and/or examine your submission related to a patent application or patent. If you do not furnish the requested information, the U.S. Patent and Trademark Office may not be able to process and/or examine your submission, which may result in termination of proceedings or abandonment of the application or expiration of the patent.

The information provided by you in this form will be subject to the following routine uses:

1. The information on this form will be treated confidentially to the extent allowed under the Freedom of Information Act (5 U.S.C. 552) and the Privacy Act (5 U.S.C. 552a). Records from this system of records may be disclosed to the Department of Justice to determine whether disclosure of these records is required by the Freedom of Information Act.
2. A record from this system of records may be disclosed, as a routine use, in the course of presenting evidence to a court, magistrate, or administrative tribunal, including disclosures to opposing counsel in the course of settlement negotiations.
3. A record in this system of records may be disclosed, as a routine use, to a Member of Congress submitting a request involving an individual, to whom the record pertains, when the individual has requested assistance from the Member with respect to the subject matter of the record.
4. A record in this system of records may be disclosed, as a routine use, to a contractor of the Agency having need for the information in order to perform a contract. Recipients of information shall be required to comply with the requirements of the Privacy Act of 1974, as amended, pursuant to 5 U.S.C. 552a(m).
5. A record related to an International Application filed under the Patent Cooperation Treaty in this system of records may be disclosed, as a routine use, to the International Bureau of the World Intellectual Property Organization, pursuant to the Patent Cooperation Treaty.
6. A record in this system of records may be disclosed, as a routine use, to another federal agency for purposes of National Security review (35 U.S.C. 181) and for review pursuant to the Atomic Energy Act (42 U.S.C. 218(c)).
7. A record from this system of records may be disclosed, as a routine use, to the Administrator, General Services, or his/her designee, during an inspection of records conducted by GSA as part of that agency's responsibility to recommend improvements in records management practices and programs, under authority of 44 U.S.C. 2904 and 2906. Such disclosure shall be made in accordance with the GSA regulations governing inspection of records for this purpose, and any other relevant (*i.e.*, GSA or Commerce) directive. Such disclosure shall not be used to make determinations about individuals.
8. A record from this system of records may be disclosed, as a routine use, to the public after either publication of the application pursuant to 35 U.S.C. 122(b) or issuance of a patent pursuant to 35 U.S.C. 151. Further, a record may be disclosed, subject to the limitations of 37 CFR 1.14, as a routine use, to the public if the record was filed in an application which became abandoned or in which the proceedings were terminated and which application is referenced by either a published application, an application open to public inspection or an issued patent.
9. A record from this system of records may be disclosed, as a routine use, to a Federal, State, or local law enforcement agency, if the USPTO becomes aware of a violation or potential violation of law or regulation.

Electronic Patent Application Fee Transmittal

Application Number:	10991774			
Filing Date:	18-Nov-2004			
Title of Invention:	Fuel management system for variable ethanol octane enhancehment of gasoline engines			
First Named Inventor/Applicant Name:	Daniel R. Cohn			
Filer:	Sam Pasternack/Elizabeth Burke			
Attorney Docket Number:	0492611-0598			
Filed as Small Entity				
Utility Filing Fees				
Description	Fee Code	Quantity	Amount	Sub-Total in USD(\$)
Basic Filing:				
Pages:				
Claims:				
Miscellaneous-Filing:				
Petition:				
Patent-Appeals-and-Interference:				
Post-Allowance-and-Post-Issuance:				
Statutory disclaimer	1814	1	130	130
Extension-of-Time:				

Description	Fee Code	Quantity	Amount	Sub-Total in USD(\$)
Miscellaneous:				
Total in USD (\$)				130

Electronic Acknowledgement Receipt

EFS ID:	2020280
Application Number:	10991774
International Application Number:	
Confirmation Number:	8282
Title of Invention:	Fuel management system for variable ethanol octane enhancehment of gasoline engines
First Named Inventor/Applicant Name:	Daniel R. Cohn
Customer Number:	24280
Filer:	Sam Pasternack/Elizabeth Burke
Filer Authorized By:	Sam Pasternack
Attorney Docket Number:	0492611-0598
Receipt Date:	27-JUL-2007
Filing Date:	18-NOV-2004
Time Stamp:	15:43:09
Application Type:	Utility under 35 USC 111(a)

Payment information:

Submitted with Payment	yes
Payment was successfully received in RAM	\$ 130
RAM confirmation Number	753
Deposit Account	

File Listing:

Document Number	Document Description	File Name	File Size(Bytes) /Message Digest	Multi Part /.zip	Pages (if appl.)
-----------------	----------------------	-----------	----------------------------------	------------------	------------------

1	Amendment - After Non-Final Rejection	MIT11381ResptoOA.pdf	90460 164e904c3f8bfeb0be650d73752f3ebcfb44a48d	no	2
Warnings:					
Information:					
2	Terminal Disclaimer Filed	MIT11381TD.pdf	198531 62ce0f4e0ff0dd448e57a008c899521b3c0ff864	no	2
Warnings:					
Information:					
3	Fee Worksheet (PTO-06)	fee-info.pdf	8179 1cfc20b342912e35027ac681ebb6cc160875cf63	no	2
Warnings:					
Information:					
Total Files Size (in bytes):			297170		
<p>This Acknowledgement Receipt evidences receipt on the noted date by the USPTO of the indicated documents, characterized by the applicant, and including page counts, where applicable. It serves as evidence of receipt similar to a Post Card, as described in MPEP 503.</p> <p><u>New Applications Under 35 U.S.C. 111</u> If a new application is being filed and the application includes the necessary components for a filing date (see 37 CFR 1.53(b)-(d) and MPEP 506), a Filing Receipt (37 CFR 1.54) will be issued in due course and the date shown on this Acknowledgement Receipt will establish the filing date of the application.</p> <p><u>National Stage of an International Application under 35 U.S.C. 371</u> If a timely submission to enter the national stage of an international application is compliant with the conditions of 35 U.S.C. 371 and other applicable requirements a Form PCT/DO/EO/903 indicating acceptance of the application as a national stage submission under 35 U.S.C. 371 will be issued in addition to the Filing Receipt, in due course.</p> <p><u>New International Application Filed with the USPTO as a Receiving Office</u> If a new international application is being filed and the international application includes the necessary components for an international filing date (see PCT Article 11 and MPEP 1810), a Notification of the International Application Number and of the International Filing Date (Form PCT/RO/105) will be issued in due course, subject to prescriptions concerning national security, and the date shown on this Acknowledgement Receipt will establish the international filing date of the application.</p>					

PATENT APPLICATION FEE DETERMINATION RECORD
Effective October 1, 2004

Application or Docket Number

10991774

CLAIMS AS FILED - PART I

	(Column 1)	(Column 2)
TOTAL CLAIMS	23	
FOR	NUMBER FILED	NUMBER EXTRA
TOTAL CHARGEABLE CLAIMS	23 minus 20 =	3
INDEPENDENT CLAIMS	2 minus 3 =	0
MULTIPLE DEPENDENT CLAIM PRESENT <input type="checkbox"/>		

* If the difference in column 1 is less than zero, enter "0" in column 2

SMALL ENTITY TYPE OR OTHER THAN SMALL ENTITY

RATE	FEE	OR	RATE	FEE
BASIC FEE	395.00		BASIC FEE	790.00
X\$ 9=	27		X\$18=	
X44=	0		X88=	
+150=	0		+300=	
TOTAL	422		TOTAL	

7/27/09 **CLAIMS AS AMENDED - PART II**

	(Column 1)	(Column 2)	(Column 3)
AMENDMENT A	CLAIMS REMAINING AFTER AMENDMENT	HIGHEST NUMBER PREVIOUSLY PAID FOR	PRESENT EXTRA
Total	4	23	0
Independent	4	4	0
FIRST PRESENTATION OF MULTIPLE DEPENDENT CLAIM <input type="checkbox"/>			

SMALL ENTITY OR OTHER THAN SMALL ENTITY

RATE	ADDITIONAL FEE	OR	RATE	ADDITIONAL FEE
X\$ 9=			X\$18=	
X44=			X88=	
+150=			+300=	
TOTAL ADDIT. FEE			TOTAL ADDIT. FEE	

1 21

	(Column 1)	(Column 2)	(Column 3)
AMENDMENT B	CLAIMS REMAINING AFTER AMENDMENT	HIGHEST NUMBER PREVIOUSLY PAID FOR	PRESENT EXTRA
Total	*	**	=
Independent	*	***	=
FIRST PRESENTATION OF MULTIPLE DEPENDENT CLAIM <input type="checkbox"/>			

RATE	ADDITIONAL FEE	OR	RATE	ADDITIONAL FEE
X\$ 9=			X\$18=	
X44=			X88=	
+150=			+300=	
TOTAL ADDIT. FEE			TOTAL ADDIT. FEE	

	(Column 1)	(Column 2)	(Column 3)
AMENDMENT C	CLAIMS REMAINING AFTER AMENDMENT	HIGHEST NUMBER PREVIOUSLY PAID FOR	PRESENT EXTRA
Total	*	**	=
Independent	*	***	=
FIRST PRESENTATION OF MULTIPLE DEPENDENT CLAIM <input type="checkbox"/>			

RATE	ADDITIONAL FEE	OR	RATE	ADDITIONAL FEE
X\$ 9=			X\$18=	
X44=			X88=	
+150=			+300=	
TOTAL ADDIT. FEE			TOTAL ADDIT. FEE	

* If the entry in column 1 is less than the entry in column 2, write "0" in column 3.
 ** If the "Highest Number Previously Paid For" IN THIS SPACE is less than 20, enter "20."
 *** If the "Highest Number Previously Paid For" IN THIS SPACE is less than 3, enter "3."
 The "Highest Number Previously Paid For" (Total or Independent) is the highest number found in the appropriate box in column 1.

Application Number 	Application/Control No. 10/991,774	Applicant(s)/Patent under Reexamination COHN ET AL.
Document Code - DISQ		Internal Document – DO NOT MAIL

TERMINAL DISCLAIMER	<input checked="" type="checkbox"/> APPROVED	<input type="checkbox"/> DISAPPROVED
Date Filed : 07/27/07	This patent is subject to a Terminal Disclaimer	REASONS:

Approved/Disapproved by:			
<input type="checkbox"/>	Sharon Greene Paralegal Specialist Technology Center 3700	<input type="checkbox"/>	Patricia Martin Paralegal Specialist Technology Center 3700
<input checked="" type="checkbox"/>	Jan Hurley Paralegal Specialist Technology Center 3700	<input type="checkbox"/>	Andre Robinson Paralegal Specialist Technology Center 3700

U.S. Patent and Trademark Office

EAST Search History

Ref #	Hits	Search Query	DBs	Default Operator	Plurals	Time Stamp
L1	3	turbocharger and spark adj ignition adj engine and port adj fuel adj injection and gasoline and knock and ethanol and vehicle and energy adj fraction	US-PGPUB	OR	OFF	2007/08/13 13:28
L2	1	turbocharger and spark adj ignition adj engine and port adj fuel adj injection and gasoline and knock and ethanol and vehicle and energy adj fraction	USPAT	OR	OFF	2007/08/13 13:27

Application Number 	Application/Control No. 10/991,774	Applicant(s)/Patent under Reexamination COHN ET AL.	
Document Code - DISQ		Internal Document – DO NOT MAIL	

TERMINAL DISCLAIMER	<input checked="" type="checkbox"/> APPROVED	<input type="checkbox"/> DISAPPROVED
Date Filed : 07/27/07	This patent is subject to a Terminal Disclaimer	REASONS:

Approved/Disapproved by:			
<input type="checkbox"/> Sharon Greene Paralegal Specialist Technology Center 3700	<input type="checkbox"/> Patricia Martin Paralegal Specialist Technology Center 3700	<input checked="" type="checkbox"/> Jan Hurley Paralegal Specialist Technology Center 3700	<input type="checkbox"/> Andre Robinson Paralegal Specialist Technology Center 3700

U.S. Patent and Trademark Office

Issue Classification 	Application/Control No. 10/991,774	Applicant(s)/Patent under Reexamination COHN ET AL.
	Examiner HYDER ALI	Art Unit 3747

ISSUE CLASSIFICATION										
ORIGINAL				INTERNATIONAL CLASSIFICATION						
CLASS		SUBCLASS		CLAIMED			NON-CLAIMED			
123		198 A		F	02	D	43	/00	/	
CROSS REFERENCES				F	02	D	41	/14	/	
CLASS	SUBCLASS (ONE SUBCLASS PER BLOCK)			F	02	M	25	/14	/	
123	435						/	/	/	
123	406.29						/	/	/	
							/	/	/	
							/	/	/	
							/	/	/	
<i>Hyder Ali</i> HYDER ALI 08/13/2007 (Assistant Examiner) (Date)				STEPHEN K. CRONIN SUPERVISORY PATENT EXAMINER (Primary Examiner) (Date)			Total Claims Allowed: 4			
(Legal Instruments Examiner) (Date)							O.G. Print Claim(s) 1		O.G. Print Fig. 1	

<input type="checkbox"/> Claims renumbered in the same order as presented by applicant		<input type="checkbox"/> CPA		<input type="checkbox"/> T.D.		<input type="checkbox"/> R.1.47							
Final	Original	Final	Original	Final	Original	Final	Original						
	1		31		61		91		121		151		181
	2		32		62		92		122		152		182
	3		33		63		93		123		153		183
	4		34		64		94		124		154		184
	5		35		65		95		125		155		185
	6		36		66		96		126		156		186
	7		37		67		97		127		157		187
	8		38		68		98		128		158		188
	9		39		69		99		129		159		189
	10		40		70		100		130		160		190
	11		41		71		101		131		161		191
	12		42		72		102		132		162		192
	13		43		73		103		133		163		193
	14		44		74		104		134		164		194
	15		45		75		105		135		165		195
	16		46		76		106		136		166		196
	17		47		77		107		137		167		197
	18		48		78		108		138		168		198
	19		49		79		109		139		169		199
	20		50		80		110		140		170		200
	21		51		81		111		141		171		201
	22		52		82		112		142		172		202
	23		53		83		113		143		173		203
	24		54		84		114		144		174		204
	25		55		85		115		145		175		205
	26		56		86		116		146		176		206
	27	1	57		87		117		147		177		207
	28	2	58		88		118		148		178		208
	29	3	59		89		119		149		179		209
	30	4	60		90		120		150		180		210



UNITED STATES PATENT AND TRADEMARK OFFICE

UNITED STATES DEPARTMENT OF COMMERCE
 United States Patent and Trademark Office
 Address: COMMISSIONER FOR PATENTS
 P.O. Box 1450
 Alexandria, Virginia 22313-1450
 www.uspto.gov



Bib Data Sheet

CONFIRMATION NO. 8282

SERIAL NUMBER 10/991,774	FILING OR 371(c) DATE 11/18/2004	CLASS 123	GROUP ART UNIT 3747	ATTORNEY DOCKET NO. 0492611-0598	
RULE					
APPLICANTS Daniel R. Cohn, Chestnut Hill, MA; Leslie Bromberg, Sharon, MA; John B. Heywood, Newton, MA;					
** CONTINUING DATA ***** NONE					
** FOREIGN APPLICATIONS ***** NONE					
IF REQUIRED, FOREIGN FILING LICENSE GRANTED ** SMALL ENTITY ** ** 03/01/2005					
Foreign Priority claimed 35 USC 119 (a-d) conditions met	<input type="checkbox"/> yes <input checked="" type="checkbox"/> no <input type="checkbox"/> yes <input checked="" type="checkbox"/> no <input type="checkbox"/> Met after	STATE OR COUNTRY MA	SHEETS DRAWING 3	TOTAL CLAIMS 56	INDEPENDENT CLAIMS 2
Verified and Acknowledged	Examiner's Signature: <u>Hyde M.</u> Allowance	Initials: <u>HA</u>			
ADDRESS 24280					
TITLE Fuel management system for variable ethanol octane enhancement of gasoline engines					
FILING FEE RECEIVED 1412	FEES: Authority has been given in Paper No. _____ to charge/credit DEPOSIT ACCOUNT No. _____ for following:		<input type="checkbox"/> All Fees <input type="checkbox"/> 1.16 Fees (Filing) <input type="checkbox"/> 1.17 Fees (Processing Ext. of time) <input type="checkbox"/> 1.18 Fees (Issue) <input type="checkbox"/> Other _____ <input type="checkbox"/> Credit		

<http://neo:8000/PrexServlet/PrexAction?serviceName=BibDataSheet&Action=display&brow...> 5/16/07

Index of Claims



Application/Control No.	Applicant(s)/Patent under Reexamined	
10/891,774	COHN ET AL.	
Examiner	Art Unit	
HYDER ALI	3747	

√ Rejected	— (Through numeral) Cancelled	N Non-Elected	A Appeal
= Allowed	◊ Restricted	I Interference	O Objected

Claim		Date	
Final	Original		
1			
2			
3			
4			
5			
6			
7			
8			
9			
10			
11			
12			
13			
14			
15			
16			
17			
18			
19			
20			
21			
22			
23			
24			
25			
26			
27			
28			
29			
30			
31			
32			
33			
34			
35			
36			
37			
38			
39			
40			
41			
42			
43			
44			
45			
46			
47			
48			
49			

Claim		Date	
Final	Original		
50			
51			
52			
53			
54			
55			
56			
57			
58			
59			
60			
61			
62			
63			
64			
65			
66			
67			
68			
69			
70			
71			
72			
73			
74			
75			
76			
77			
78			
79			
80			
81			
82			
83			
84			
85			
86			
87			
88			
89			
90			
91			
92			
93			
94			
95			
96			
97			
98			
99			
100			

Claim		Date	
Final	Original		
101			
102			
103			
104			
105			
106			
107			
108			
109			
110			
111			
112			
113			
114			
115			
116			
117			
118			
119			
120			
121			
122			
123			
124			
125			
126			
127			
128			
129			
130			
131			
132			
133			
134			
135			
136			
137			
138			
139			
140			
141			
142			
143			
144			
145			
146			
147			
148			
149			
150			

Search Notes



Application/Control No.	Applicant(s)/Patent under Reexamination	
10/991,774	COHN ET AL.	
Examiner	Art Unit	
HYDER ALI	3747	

SEARCHED			
Class	Subclass	Date	Examiner
123	1A	4/17/2008	HA
123	1B8A	4/17/2008	HA
123	525	4/17/2008	HA
123	25A	4/17/2008	HA
123	25J	4/17/2008	HA
123	435	9/19/06	HA
123	575	9/19/06	HA
123	406.29	9/19/06	HA
123	406.47	9/19/06	HA
UPDATED		9/19/06	HA
UPDATED		12/14/06	HA
UPDATED		5/16/07	HA
UPDATED		8/13/07	HA

INTERFERENCE SEARCHED			
Class	Subclass	Date	Examiner
Interference Search history Printout.		8/13/07	HA

SEARCH NOTES (INCLUDING SEARCH STRATEGY)		
	DATE	EXMR
SEARCHED EAST SEE EAST SEARCH PRINT OUT.	4/17/2008	HA



UNITED STATES PATENT AND TRADEMARK OFFICE

UNITED STATES DEPARTMENT OF COMMERCE
United States Patent and Trademark Office
Address: COMMISSIONER FOR PATENTS
P.O. Box 1450
Alexandria, Virginia 22313-1450
www.uspto.gov

NOTICE OF ALLOWANCE AND FEE(S) DUE

24280 7590 08/16/2007
CHOATE, HALL & STEWART LLP
TWO INTERNATIONAL PLACE
BOSTON, MA 02110

EXAMINER

ALI, HYDER

ART UNIT PAPER NUMBER

3747

DATE MAILED: 08/16/2007

Table with 5 columns: APPLICATION NO., FILING DATE, FIRST NAMED INVENTOR, ATTORNEY DOCKET NO., CONFIRMATION NO.
10/991,774 11/18/2004 Daniel R. Cohn 0492611-0598 8282

TITLE OF INVENTION: FUEL MANAGEMENT SYSTEM FOR VARIABLE ETHANOL OCTANE ENHANCEMENT OF GASOLINE ENGINES

Table with 7 columns: APPLN. TYPE, SMALL ENTITY, ISSUE FEE DUE, PUBLICATION FEE DUE, PREV. PAID ISSUE FEE, TOTAL FEE(S) DUE, DATE DUE
nonprovisional YES \$700 \$300 \$0 \$1000 11/16/2007

THE APPLICATION IDENTIFIED ABOVE HAS BEEN EXAMINED AND IS ALLOWED FOR ISSUANCE AS A PATENT. PROSECUTION ON THE MERITS IS CLOSED. THIS NOTICE OF ALLOWANCE IS NOT A GRANT OF PATENT RIGHTS. THIS APPLICATION IS SUBJECT TO WITHDRAWAL FROM ISSUE AT THE INITIATIVE OF THE OFFICE OR UPON PETITION BY THE APPLICANT. SEE 37 CFR 1.313 AND MPEP 1308.

THE ISSUE FEE AND PUBLICATION FEE (IF REQUIRED) MUST BE PAID WITHIN THREE MONTHS FROM THE MAILING DATE OF THIS NOTICE OR THIS APPLICATION SHALL BE REGARDED AS ABANDONED. THIS STATUTORY PERIOD CANNOT BE EXTENDED. SEE 35 U.S.C. 151. THE ISSUE FEE DUE INDICATED ABOVE DOES NOT REFLECT A CREDIT FOR ANY PREVIOUSLY PAID ISSUE FEE IN THIS APPLICATION. IF AN ISSUE FEE HAS PREVIOUSLY BEEN PAID IN THIS APPLICATION (AS SHOWN ABOVE), THE RETURN OF PART B OF THIS FORM WILL BE CONSIDERED A REQUEST TO REAPPLY THE PREVIOUSLY PAID ISSUE FEE TOWARD THE ISSUE FEE NOW DUE.

HOW TO REPLY TO THIS NOTICE:

I. Review the SMALL ENTITY status shown above.

If the SMALL ENTITY is shown as YES, verify your current SMALL ENTITY status:

- A. If the status is the same, pay the TOTAL FEE(S) DUE shown above.
B. If the status above is to be removed, check box 5b on Part B - Fee(s) Transmittal and pay the PUBLICATION FEE (if required) and twice the amount of the ISSUE FEE shown above, or

If the SMALL ENTITY is shown as NO:

- A. Pay TOTAL FEE(S) DUE shown above, or
B. If applicant claimed SMALL ENTITY status before, or is now claiming SMALL ENTITY status, check box 5a on Part B - Fee(s) Transmittal and pay the PUBLICATION FEE (if required) and 1/2 the ISSUE FEE shown above.

II. PART B - FEE(S) TRANSMITTAL, or its equivalent, must be completed and returned to the United States Patent and Trademark Office (USPTO) with your ISSUE FEE and PUBLICATION FEE (if required). If you are charging the fee(s) to your deposit account, section "4b" of Part B - Fee(s) Transmittal should be completed and an extra copy of the form should be submitted. If an equivalent of Part B is filed, a request to reapply a previously paid issue fee must be clearly made, and delays in processing may occur due to the difficulty in recognizing the paper as an equivalent of Part B.

III. All communications regarding this application must give the application number. Please direct all communications prior to issuance to Mail Stop ISSUE FEE unless advised to the contrary.

IMPORTANT REMINDER: Utility patents issuing on applications filed on or after Dec. 12, 1980 may require payment of maintenance fees. It is patentee's responsibility to ensure timely payment of maintenance fees when due.

PART B - FEE(S) TRANSMITTAL

Complete and send this form, together with applicable fee(s), to: **Mail** **Mail Stop ISSUE FEE
Commissioner for Patents
P.O. Box 1450
Alexandria, Virginia 22313-1450**
or **Fax** **(571)-273-2885**

INSTRUCTIONS: This form should be used for transmitting the ISSUE FEE and PUBLICATION FEE (if required). Blocks 1 through 5 should be completed where appropriate. All further correspondence including the Patent, advance orders and notification of maintenance fees will be mailed to the current correspondence address as indicated unless corrected below or directed otherwise in Block 1, by (a) specifying a new correspondence address; and/or (b) indicating a separate "FEE ADDRESS" for maintenance fee notifications.

CURRENT CORRESPONDENCE ADDRESS (Note: Use Block 1 for any change of address)

24280 7590 08/16/2007
CHOATE, HALL & STEWART LLP
TWO INTERNATIONAL PLACE
BOSTON, MA 02110

Note: A certificate of mailing can only be used for domestic mailings of the Fee(s) Transmittal. This certificate cannot be used for any other accompanying papers. Each additional paper, such as an assignment or formal drawing, must have its own certificate of mailing or transmission.

Certificate of Mailing or Transmission

I hereby certify that this Fee(s) Transmittal is being deposited with the United States Postal Service with sufficient postage for first class mail in an envelope addressed to the Mail Stop ISSUE FEE address above, or being facsimile transmitted to the USPTO (571) 273-2885, on the date indicated below.

(Depositor's name)
(Signature)
(Date)

APPLICATION NO.	FILING DATE	FIRST NAMED INVENTOR	ATTORNEY DOCKET NO.	CONFIRMATION NO.
10/991,774	11/18/2004	Daniel R. Cohn	0492611-0598	8282

TITLE OF INVENTION: FUEL MANAGEMENT SYSTEM FOR VARIABLE ETHANOL OCTANE ENHANCEMENT OF GASOLINE ENGINES

APPLN. TYPE	SMALL ENTITY	ISSUE FEE DUE	PUBLICATION FEE DUE	PREV. PAID ISSUE FEE	TOTAL FEE(S) DUE	DATE DUE
nonprovisional	YES	\$700	\$300	\$0	\$1000	11/16/2007

EXAMINER	ART UNIT	CLASS-SUBCLASS
ALI, HYDER	3747	123-19800A

<p>1. Change of correspondence address or indication of "Fee Address" (37 CFR 1.363).</p> <p><input type="checkbox"/> Change of correspondence address (or Change of Correspondence Address form PTO/SB/122) attached.</p> <p><input type="checkbox"/> "Fee Address" indication (or "Fee Address" Indication form PTO/SB/47; Rev 03-02 or more recent) attached. Use of a Customer Number is required.</p>	<p>2. For printing on the patent front page, list</p> <p>(1) the names of up to 3 registered patent attorneys or agents OR, alternatively, _____ 1</p> <p>(2) the name of a single firm (having as a member a registered attorney or agent) and the names of up to 2 registered patent attorneys or agents. If no name is listed, no name will be printed. _____ 2</p> <p>_____ 3</p>
---	---

3. ASSIGNEE NAME AND RESIDENCE DATA TO BE PRINTED ON THE PATENT (print or type)

PLEASE NOTE: Unless an assignee is identified below, no assignee data will appear on the patent. If an assignee is identified below, the document has been filed for recordation as set forth in 37 CFR 3.11. Completion of this form is NOT a substitute for filing an assignment.

(A) NAME OF ASSIGNEE _____ (B) RESIDENCE: (CITY and STATE OR COUNTRY) _____

Please check the appropriate assignee category or categories (will not be printed on the patent) : Individual Corporation or other private group entity Government

<p>4a. The following fee(s) are submitted:</p> <p><input type="checkbox"/> Issue Fee</p> <p><input type="checkbox"/> Publication Fee (No small entity discount permitted)</p> <p><input type="checkbox"/> Advance Order - # of Copies _____</p>	<p>4b. Payment of Fee(s): (Please first reapply any previously paid issue fee shown above)</p> <p><input type="checkbox"/> A check is enclosed.</p> <p><input type="checkbox"/> Payment by credit card. Form PTO-2038 is attached.</p> <p><input type="checkbox"/> The Director is hereby authorized to charge the required fee(s), any deficiency, or credit any overpayment, to Deposit Account Number _____ (enclose an extra copy of this form).</p>
---	--

5. Change in Entity Status (from status indicated above)

a. Applicant claims SMALL ENTITY status. See 37 CFR 1.27. b. Applicant is no longer claiming SMALL ENTITY status. See 37 CFR 1.27(g)(2).

NOTE: The Issue Fee and Publication Fee (if required) will not be accepted from anyone other than the applicant; a registered attorney or agent; or the assignee or other party in interest as shown by the records of the United States Patent and Trademark Office.

Authorized Signature _____ Date _____

Typed or printed name _____ Registration No. _____

This collection of information is required by 37 CFR 1.311. The information is required to obtain or retain a benefit by the public which is to file (and by the USPTO to process) an application. Confidentiality is governed by 35 U.S.C. 122 and 37 CFR 1.14. This collection is estimated to take 12 minutes to complete, including gathering, preparing, and submitting the completed application form to the USPTO. Time will vary depending upon the individual case. Any comments on the amount of time you require to complete this form and/or suggestions for reducing this burden, should be sent to the Chief Information Officer, U.S. Patent and Trademark Office, U.S. Department of Commerce, P.O. Box 1450, Alexandria, Virginia 22313-1450. DO NOT SEND FEES OR COMPLETED FORMS TO THIS ADDRESS. SEND TO: Commissioner for Patents, P.O. Box 1450, Alexandria, Virginia 22313-1450.

Under the Paperwork Reduction Act of 1995, no persons are required to respond to a collection of information unless it displays a valid OMB control number.



UNITED STATES PATENT AND TRADEMARK OFFICE

UNITED STATES DEPARTMENT OF COMMERCE
United States Patent and Trademark Office
Address: COMMISSIONER FOR PATENTS
P.O. Box 1450
Alexandria, Virginia 22313-1450
www.uspto.gov

APPLICATION NO.	FILING DATE	FIRST NAMED INVENTOR	ATTORNEY DOCKET NO.	CONFIRMATION NO.
10/991,774	11/18/2004	Daniel R. Cohn	0492611-0598	8282
24280	7590	08/16/2007	EXAMINER	
CHOATE, HALL & STEWART LLP TWO INTERNATIONAL PLACE BOSTON, MA 02110			ALI, HYDER	
			ART UNIT	PAPER NUMBER
			3747	
DATE MAILED: 08/16/2007				

Determination of Patent Term Adjustment under 35 U.S.C. 154 (b)
(application filed on or after May 29, 2000)

The Patent Term Adjustment to date is 25 day(s). If the issue fee is paid on the date that is three months after the mailing date of this notice and the patent issues on the Tuesday before the date that is 28 weeks (six and a half months) after the mailing date of this notice, the Patent Term Adjustment will be 25 day(s).

If a Continued Prosecution Application (CPA) was filed in the above-identified application, the filing date that determines Patent Term Adjustment is the filing date of the most recent CPA.

Applicant will be able to obtain more detailed information by accessing the Patent Application Information Retrieval (PAIR) WEB site (<http://pair.uspto.gov>).

Any questions regarding the Patent Term Extension or Adjustment determination should be directed to the Office of Patent Legal Administration at (571)-272-7702. Questions relating to issue and publication fee payments should be directed to the Customer Service Center of the Office of Patent Publication at 1-(888)-786-0101 or (571)-272-4200.

ED

Notice of Allowability	Application No.	Applicant(s)	
	10/991,774	COHN ET AL.	
	Examiner	Art Unit	
	HYDER ALI	3747	

-- The MAILING DATE of this communication appears on the cover sheet with the correspondence address--

All claims being allowable, PROSECUTION ON THE MERITS IS (OR REMAINS) CLOSED in this application. If not included herewith (or previously mailed), a Notice of Allowance (PTOL-85) or other appropriate communication will be mailed in due course. **THIS NOTICE OF ALLOWABILITY IS NOT A GRANT OF PATENT RIGHTS.** This application is subject to withdrawal from issue at the initiative of the Office or upon petition by the applicant. See 37 CFR 1.313 and MPEP 1308.

1. This communication is responsive to Arguments/Remarks filed on 07/27/2007.
2. The allowed claim(s) is/are 57-60.
3. Acknowledgment is made of a claim for foreign priority under 35 U.S.C. § 119(a)-(d) or (f).
 - a) All b) Some* c) None of the:
 1. Certified copies of the priority documents have been received.
 2. Certified copies of the priority documents have been received in Application No. _____.
 3. Copies of the certified copies of the priority documents have been received in this national stage application from the International Bureau (PCT Rule 17.2(a)).

* Certified copies not received: _____.

Applicant has THREE MONTHS FROM THE "MAILING DATE" of this communication to file a reply complying with the requirements noted below. Failure to timely comply will result in ABANDONMENT of this application. **THIS THREE-MONTH PERIOD IS NOT EXTENDABLE.**

4. A SUBSTITUTE OATH OR DECLARATION must be submitted. Note the attached EXAMINER'S AMENDMENT or NOTICE OF INFORMAL PATENT APPLICATION (PTO-152) which gives reason(s) why the oath or declaration is deficient.
 5. CORRECTED DRAWINGS (as "replacement sheets") must be submitted.
 - (a) including changes required by the Notice of Draftsperson's Patent Drawing Review (PTO-948) attached
 - 1) hereto or 2) to Paper No./Mail Date _____.
 - (b) including changes required by the attached Examiner's Amendment / Comment or in the Office action of Paper No./Mail Date _____.
- Identifying indicia such as the application number (see 37 CFR 1.84(c)) should be written on the drawings in the front (not the back) of each sheet. Replacement sheet(s) should be labeled as such in the header according to 37 CFR 1.121(d).
6. DEPOSIT OF and/or INFORMATION about the deposit of BIOLOGICAL MATERIAL must be submitted. Note the attached Examiner's comment regarding REQUIREMENT FOR THE DEPOSIT OF BIOLOGICAL MATERIAL.

Attachment(s)

- | | |
|--|--|
| 1. <input type="checkbox"/> Notice of References Cited (PTO-892) | 5. <input type="checkbox"/> Notice of Informal Patent Application |
| 2. <input type="checkbox"/> Notice of Draftsperson's Patent Drawing Review (PTO-948) | 6. <input type="checkbox"/> Interview Summary (PTO-413),
Paper No./Mail Date _____. |
| 3. <input type="checkbox"/> Information Disclosure Statements (PTO/SB/08),
Paper No./Mail Date _____ | 7. <input checked="" type="checkbox"/> Examiner's Amendment/Comment |
| 4. <input type="checkbox"/> Examiner's Comment Regarding Requirement for Deposit
of Biological Material | 8. <input type="checkbox"/> Examiner's Statement of Reasons for Allowance |
| | 9. <input type="checkbox"/> Other _____. |

Hyder Ali

EXAMINER'S AMENDMENT

An examiner's amendment to the record appears below. Should the changes and/or additions be unacceptable to applicant, an amendment may be filed as provided by 37 CFR 1.312. To ensure consideration of such an amendment, it MUST be submitted no later than the payment of the issue fee.

The application has been amended as follows:

Oath/Declaration Objection

Oath/Declaration is objected to because the oath/declaration duty to disclose statement is improper.

The oath or declaration is defective. A new oath or declaration in compliance with 37 CFR 1.67(a) identifying this application by application number and filing date is required. See MPEP §§ 602.01 and 602.02.

The oath or declaration is defective because:

It does not state that the person making the oath or declaration acknowledges the duty to disclose to the Office all information known to the person to be material to patentability as defined in 37 CFR 1.56.

Any inquiry concerning this communication or earlier communications from the examiner should be directed to HYDER ALI whose telephone number is (571) 272-4836. The examiner can normally be reached on M-F (8:30-5:00).

If attempts to reach the examiner by telephone are unsuccessful, the examiner's supervisor, Stephen Kirk Cronin can be reached on (571) 272-4536. The fax phone number for the organization where this application or proceeding is assigned is 571-273-8300.

Information regarding the status of an application may be obtained from the Patent Application Information Retrieval (PAIR) system. Status information for published applications may be obtained from either Private PAIR or Public PAIR. Status information for unpublished applications is available through Private PAIR only. For more information about the PAIR system, see <http://pair-direct.uspto.gov>. Should you have questions on access to the Private PAIR system, contact the Electronic Business Center (EBC) at 866-217-9197 (toll-free). If you would like assistance from a USPTO Customer Service Representative or access to the automated information system, call 800-786-9199 (IN USA OR CANADA) or 571-272-1000.

ha

STEPHEN K. CRONIN
SUPERVISORY PATENT EXAMINER

PART B - FEE(S) TRANSMITTAL

Complete and send this form, together with applicable fee(s), to: **Mail** Mail Stop ISSUE FEE
Commissioner for Patents
P.O. Box 1450
Alexandria, Virginia 22313-1450
or Fax (571)-273-2885

INSTRUCTIONS: This form should be used for transmitting the ISSUE FEE and PUBLICATION FEE (if required). Blocks 1 through 5 should be completed where appropriate. All further correspondence including the Patent, advance orders and notification of maintenance fees will be mailed to the current correspondence address as indicated unless corrected below or directed otherwise in Block 1, by (a) specifying a new correspondence address; and/or (b) indicating a separate "FEE ADDRESS" for maintenance fee notifications.

CURRENT CORRESPONDENCE ADDRESS (Note: Use Block 1 for any change of address)

24280 7590 08/16/2007

CHOATE, HALL & STEWART LLP
TWO INTERNATIONAL PLACE
BOSTON, MA 02110

Note: A certificate of mailing can only be used for domestic mailings of the Fee(s) Transmittal. This certificate cannot be used for any other accompanying papers. Each additional paper, such as an assignment or formal drawing, must have its own certificate of mailing or transmission.

Certificate of Mailing or Transmission

I hereby certify that this Fee(s) Transmittal is being deposited with the United States Postal Service with sufficient postage for first class mail in an envelope addressed to the Mail Stop ISSUE FEE address above, or being facsimile transmitted to the USPTO (571) 273-2885, on the date indicated below.

(Depositor's name)
(Signature)
(Date)

APPLICATION NO.	FILING DATE	FIRST NAMED INVENTOR	ATTORNEY DOCKET NO.	CONFIRMATION NO.
10/991,774	11/18/2004	Daniel R. Cohn	0492611-0598	8282

TITLE OF INVENTION: FUEL MANAGEMENT SYSTEM FOR VARIABLE ETHANOL OCTANE ENHANCEMENT OF GASOLINE ENGINES

APPLN. TYPE	SMALL ENTITY	ISSUE FEE DUE	PUBLICATION FEE DUE	PREV. PAID ISSUE FEE	TOTAL FEE(S) DUE	DATE DUE
nonprovisional	YES	\$700	\$300	\$0	\$1000	11/16/2007

EXAMINER	ART UNIT	CLASS-SUBCLASS
ALI, HYDER	3747	123-19800A

1. Change of correspondence address or indication of "Fee Address" (37 CFR 1.563).
 Change of correspondence address (or Change of Correspondence Address form PTO/SB/122) attached.
 "Fee Address" indication (or "Fee Address" Indication form PTO/SB/47; Rev 03-02 or more recent) attached. Use of a Customer Number is required.

2. For printing on the patent front page, list
 (1) the names of up to 3 registered patent attorneys or agents OR, alternatively,
 (2) the name of a single firm (having as a member a registered attorney or agent) and the names of up to 2 registered patent attorneys or agents. If no name is listed, no name will be printed.

1 Sam Pasternack
 2 Choate Hall & Stewart, LLP
 3 _____

3. ASSIGNEE NAME AND RESIDENCE DATA TO BE PRINTED ON THE PATENT (print or type)

PLEASE NOTE: Unless an assignee is identified below, no assignee data will appear on the patent. If an assignee is identified below, the document has been filed for recordation as set forth in 37 CFR 3.11. Completion of this form is NOT a substitute for filing an assignment.

(A) NAME OF ASSIGNEE

(B) RESIDENCE: (CITY AND STATE OR COUNTRY)

Massachusetts Institute of Technology

Cambridge, Massachusetts

Please check the appropriate assignee category or categories (will not be printed on the patent) : Individual Corporation or other private group entity Government

4a. The following fee(s) are submitted:

- Issue Fee
 Publication Fee (No small entity discount permitted)
 Advance Order - # of Copies _____

4b. Payment of Fee(s): (Please first reapply any previously paid issue fee shown above)

- A check is enclosed.
 Payment by credit card. Form PTO-2038 is attached.
 The Director is hereby authorized to charge the required fee(s), any deficiency, or credit any overpayment, to Deposit Account Number 03-1721 (enclose an extra copy of this form).

5. Change in Entity Status (from status indicated above)

- a. Applicant claims SMALL ENTITY status. See 37 CFR 1.27. b. Applicant is no longer claiming SMALL ENTITY status. See 37 CFR 1.27(g)(2).

NOTE: The Issue Fee and Publication Fee (if required) will not be accepted from anyone other than the applicant; a registered attorney or agent; or the assignee or other party in interest as shown by the records of the United States Patent and Trademark Office.

Authorized Signature /SamPasternack/
 Typed or printed name Sam Pasternack

Date November 15, 2007
 Registration No. 29,576

This collection of information is required by 37 CFR 1.311. The information is required to obtain or retain a benefit by the public which is to file (and by the USPTO to process) an application. Confidentiality is governed by 35 U.S.C. 122 and 37 CFR 1.14. This collection is estimated to take 12 minutes to complete, including gathering, preparing, and submitting the completed application form to the USPTO. Time will vary depending upon the individual case. Any comments on the amount of time you require to complete this form and/or suggestions for reducing this burden, should be sent to the Chief Information Officer, U.S. Patent and Trademark Office, U.S. Department of Commerce, P.O. Box 1450, Alexandria, Virginia 22313-1450. DO NOT SEND FEES OR COMPLETED FORMS TO THIS ADDRESS. SEND TO: Commissioner for Patents, P.O. Box 1450, Alexandria, Virginia 22313-1450.

Under the Paperwork Reduction Act of 1995, no persons are required to respond to a collection of information unless it displays a valid OMB control number.

DECLARATION

As a below named inventor, I hereby declare that:

My residence, post office address and citizenship are as stated below next to my name,

I believe I am the original, first and sole inventor (if only one name is listed below) or an original, first and joint inventor (if plural names are listed below) of the subject matter which is claimed and for which a patent is sought on the invention entitled:

**FUEL MANAGEMENT SYSTEM FOR VARIABLE ETHANOL OCTANE
ENHANCEMENT OF GASOLINE ENGINES**

the specification of which:

_____ is attached hereto;

X was filed on November 18, 2004 as Application Serial No. 10/991,774 and amended on _____ (if applicable); or

_____ was filed as PCT international application No. _____, on _____ and was amended under PCT Article 19 on _____ (if applicable).

I hereby state that I have reviewed and understood the contents of the above-identified specification, including the claims, as amended by any amendment referred to above.

I acknowledged the duty to disclose information which is material to the examination of this application in accordance with Title 37, Code of Federal Regulations, §1.56.

I hereby claim foreign priority benefits under Title 35, United States Code, §119 of any foreign application(s) for patent or inventor's certificate listed below and have also identified below any foreign application for patent or inventor's certificate having a filing date before that of the application on which priority is claimed:

Prior Foreign Application(s):

<i>Number</i>	<i>Country</i>	<i>Filing Date</i>	<i>Status</i>	<i>Priority Claimed (Y/N)</i>

I hereby claim the benefit under Title 35, United States Code, §120 of any United States application(s) or PCT international application(s) designating the United States of America listed

below and, insofar as the subject matter of each of the claims of this application is not disclosed in the prior United States application in the manner provided by the first paragraph of Title 35, United States Code, §112, I acknowledge the duty to disclose material information as defined in Title 37, Code of Federal Regulations, §1.56 which became available between the filing date of the prior application and the national or PCT international filing date of this application:

Prior US National Application(s) Application(s) and PCT Applications Designating the US:

Number	Country	Filing Date	Status	Priority Claimed (Y/N)

I hereby claim the benefit under Title 35, United States Code, §119(e) of any United States provisional application(s) listed below and, insofar as the subject matter of each of the claims of this application is not disclosed in the prior United States application in the manner provided by the first paragraph of Title 35, United States Code, §112, I acknowledge the duty to disclose information which is material to patentability as defined in Title 37, Code of Federal Regulations, §1.56 which became available between the filing date of the prior application and the national filing date of this application.

Prior US Provisional Application(s):

Number	Country	Filing Date	Status	Priority Claimed (Y/N)

I hereby declare that all statements made herein of my own knowledge are true and that all statements made on information and belief are believed to be true; and further that these statements were made with the knowledge that willful false statements and the like so made are punishable by fine or imprisonment, or both, under Section 1001 of Title 18 of the United States Code and that such willful false statements may jeopardize the validity of the application or any patents issued thereon.

Name:	Daniel R. Cohn		
Signature:	<i>Daniel R. Cohn</i>	Date:	Nov. 19, 2007
Residence Address:	600 Memorial Dr. Apt 11-22B Cambridge, MA 02142	Citizenship:	USA
Correspondence Address:	Same as above		

Name:	Leslie Bromberg		
Signature:	<i>Leslie Bromberg</i>	Date:	11/15/07
Residence Address:	176 WILSHIRE DR, SHARON MA	Citizenship:	US
Correspondence Address:			

Name:	John B. Heywood		
Signature:		Date:	
Residence Address:		Citizenship:	
Correspondence Address:			

Name:	Leslie Bromberg		
Signature:		Date:	
Residence Address:		Citizenship:	
Correspondence Address:			

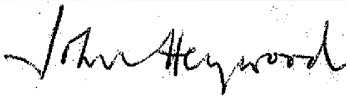
Name:	John B. Heywood		
Signature:		Date:	11/01/2007
Residence Address:	218 Mill Street Newton, Massachusetts 02460	Citizenship:	USA
Correspondence Address:	MIT, Department of Mechanical Engineering 77 Massachusetts Avenue, 3-340 Cambridge, MA 02139		

Electronic Patent Application Fee Transmittal

Application Number:	10991774			
Filing Date:	18-Nov-2004			
Title of Invention:	FUEL MANAGEMENT SYSTEM FOR VARIABLE ETHANOL OCTANE ENHANCEMENT OF GASOLINE ENGINES			
First Named Inventor/Applicant Name:	Daniel R. Cohn			
Filer:	Sam Pasternack/Elisabeth Dunkle			
Attorney Docket Number:	0492611-0598			
Filed as Small Entity				
Utility Filing Fees				
Description	Fee Code	Quantity	Amount	Sub-Total in USD(\$)
Basic Filing:				
Pages:				
Claims:				
Miscellaneous-Filing:				
Publ. Fee- early, voluntary, or normal	1504	1	300	300
Petition:				
Patent-Appeals-and-Interference:				
Post-Allowance-and-Post-Issuance:				
Utility Appl issue fee	2501	1	720	720

Description	Fee Code	Quantity	Amount	Sub-Total in USD(\$)
Extension-of-Time:				
Miscellaneous:				
Total in USD (\$)				1020

Electronic Acknowledgement Receipt

EFS ID:	2470567
Application Number:	10991774
International Application Number:	
Confirmation Number:	8282
Title of Invention:	FUEL MANAGEMENT SYSTEM FOR VARIABLE ETHANOL OCTANE ENHANCEMENT OF GASOLINE ENGINES
First Named Inventor/Applicant Name:	Daniel R. Cohn
Customer Number:	24280
Filer:	Sam Pasternack/Elisabeth Dunkle
Filer Authorized By:	Sam Pasternack
Attorney Docket Number:	0492611-0598
Receipt Date:	15-NOV-2007
Filing Date:	18-NOV-2004
Time Stamp:	15:47:29
Application Type:	Utility under 35 USC 111(a)

Payment information:

Submitted with Payment	yes
Payment Type	Credit Card
Payment was successfully received in RAM	\$ 1020
RAM confirmation Number	1167
Deposit Account	
Authorized User	

File Listing:

Document Number	Document Description	File Name	File Size(Bytes) /Message Digest	Multi Part /.zip	Pages (if appl.)
-----------------	----------------------	-----------	----------------------------------	------------------	------------------

1	Issue Fee Payment (PTO-85B)	IssueFeeTrans.pdf	136900 c3cd1bb389db44f1cd255f94a2b1811ecb9aaafaa	no	1
Warnings:					
Information:					
2	Oath or Declaration filed	Declaration.pdf	197104 59e6fd88df9816bc8933d9a2677cf883c1ec0430	no	4
Warnings:					
Information:					
3	Fee Worksheet (PTO-06)	fee-info.pdf	8344 8377dff58d47551cc9b1293a1a32349735227810	no	2
Warnings:					
Information:					
Total Files Size (in bytes):				342348	
<p>This Acknowledgement Receipt evidences receipt on the noted date by the USPTO of the indicated documents, characterized by the applicant, and including page counts, where applicable. It serves as evidence of receipt similar to a Post Card, as described in MPEP 503.</p> <p><u>New Applications Under 35 U.S.C. 111</u> If a new application is being filed and the application includes the necessary components for a filing date (see 37 CFR 1.53(b)-(d) and MPEP 506), a Filing Receipt (37 CFR 1.54) will be issued in due course and the date shown on this Acknowledgement Receipt will establish the filing date of the application.</p> <p><u>National Stage of an International Application under 35 U.S.C. 371</u> If a timely submission to enter the national stage of an international application is compliant with the conditions of 35 U.S.C. 371 and other applicable requirements a Form PCT/DO/EO/903 indicating acceptance of the application as a national stage submission under 35 U.S.C. 371 will be issued in addition to the Filing Receipt, in due course.</p> <p><u>New International Application Filed with the USPTO as a Receiving Office</u> If a new international application is being filed and the international application includes the necessary components for an international filing date (see PCT Article 11 and MPEP 1810), a Notification of the International Application Number and of the International Filing Date (Form PCT/RO/105) will be issued in due course, subject to prescriptions concerning national security, and the date shown on this Acknowledgement Receipt will establish the international filing date of the application.</p>					



UNITED STATES PATENT AND TRADEMARK OFFICE

UNITED STATES DEPARTMENT OF COMMERCE
United States Patent and Trademark Office
Address: COMMISSIONER FOR PATENTS
P.O. Box 1450
Alexandria, Virginia 22313-1450
www.uspto.gov

APPLICATION NO.	ISSUE DATE	PATENT NO.	ATTORNEY DOCKET NO.	CONFIRMATION NO.
10/991,774	01/01/2008	7314033	0492611-0598	8282

24280 7590 12/12/2007
CHOATE, HALL & STEWART LLP
TWO INTERNATIONAL PLACE
BOSTON, MA 02110

ISSUE NOTIFICATION

The projected patent number and issue date are specified above.

Determination of Patent Term Adjustment under 35 U.S.C. 154 (b)
(application filed on or after May 29, 2000)

The Patent Term Adjustment is 0 day(s). Any patent to issue from the above-identified application will include an indication of the adjustment on the front page.

If a Continued Prosecution Application (CPA) was filed in the above-identified application, the filing date that determines Patent Term Adjustment is the filing date of the most recent CPA.

Applicant will be able to obtain more detailed information by accessing the Patent Application Information Retrieval (PAIR) WEB site (<http://pair.uspto.gov>).

Any questions regarding the Patent Term Extension or Adjustment determination should be directed to the Office of Patent Legal Administration at (571)-272-7702. Questions relating to issue and publication fee payments should be directed to the Customer Service Center of the Office of Patent Publication at (571)-272-4200.

APPLICANT(s) (Please see PAIR WEB site <http://pair.uspto.gov> for additional applicants):

Daniel R. Cohn, Chestnut Hill, MA;
Leslie Bromberg, Sharon, MA;
John B. Heywood, Newton, MA;

Approved for use through 07/31/2012. OMB 0651-0031
U.S. Patent and Trademark Office; U.S. DEPARTMENT OF COMMERCE

Under the Paperwork Reduction Act of 1995, no persons are required to respond to a collection of information unless it displays a valid OMB control number.

STATEMENT UNDER 37 CFR 3.73(b)

Applicant/Patent Owner: Daniel R. Cohn et al.

Application No./Patent No.: 10991774/7314033

Filed/Issue Date: 11/18/2004 / 01/01/2008

Titled: **COMPENSATION FOR MEASUREMENT UNCERTAINTY DUE TO ATMOSPHERIC EFFECTS**

Massachusetts Institute of Technology, a non-profit

(Name of Assignee)

(Type of Assignee, e.g., corporation, partnership, university, government agency, etc.)

states that it is:

- 1. the assignee of the entire right, title, and interest in;
- 2. an assignee of less than the entire right, title, and interest in (The extent (by percentage) of its ownership interest is _____ %); or
- 3. the assignee of an undivided interest in the entirety of (a complete assignment from one of the joint inventors was made) the patent application/patent identified above, by virtue of either:

A. An assignment from the inventor(s) of the patent application/patent identified above. The assignment was recorded in the United States Patent and Trademark Office at Reel 016336, Frame 0049, or for which a copy therefore is attached.

OR

B. A chain of title from the inventor(s), of the patent application/patent identified above, to the current assignee as follows:

1. From: _____ To: _____

The document was recorded in the United States Patent and Trademark Office at Reel _____, Frame _____, or for which a copy thereof is attached.

2. From: _____ To: _____

The document was recorded in the United States Patent and Trademark Office at Reel _____, Frame _____, or for which a copy thereof is attached.

3. From: _____ To: _____

The document was recorded in the United States Patent and Trademark Office at Reel _____, Frame _____, or for which a copy thereof is attached.

Additional documents in the chain of title are listed on a supplemental sheet(s).

As required by 37 CFR 3.73(b)(1)(i), the documentary evidence of the chain of title from the original owner to the assignee was, or concurrently is being, submitted for recordation pursuant to 37 CFR 3.11.

(NOTE: A separate copy (i.e., a true copy of the original assignment document(s)) must be submitted to Assignment Division in accordance with 37 CFR Part 3, to record the assignment in the records of the USPTO. See MPEP 302.08]

The undersigned (whose title is supplied below) is authorized to act on behalf of the assignee.

Signature

01/14/2010
Date

Daniel O'Brien
Printed or Typed Name

IP Manager
Title

This collection of information is required by 37 CFR 3.73(b). The information is required to obtain or retain a benefit by the public which is to file (and by the USPTO to process) an application. Confidentiality is governed by 35 U.S.C. 122 and 37 CFR 1.11 and 1.14. This collection is estimated to take 12 minutes to complete, including gathering, preparing, and submitting the completed application form to the USPTO. Time will vary depending upon the individual case. Any comments on the amount of time you require to complete this form and/or suggestions for reducing this burden, should be sent to the Chief Information Officer, U.S. Patent and Trademark Office, U.S. Department of Commerce, P.O. Box 1450, Alexandria, VA 22313-1450. DO NOT SEND FEES OR COMPLETED FORMS TO THIS ADDRESS. SEND TO: Commissioner for Patents, P.O. Box 1460, Alexandria, VA 22313-1460.

if you need assistance in completing the form, call 1-800-PTO-9199 and select option 2.

Jan 14 2010 4:12PM

Technology Licensing Office 617 258 6790

RECEIVED
CENTRAL FAX CENTER

JAN 14 2010

Massachusetts Institute of Technology
Five Cambridge Center, Kendall Square
Building NE25-230
Cambridge, MA 02142-1493
Phone: 617-253-6966
Fax: 617-258-6790
<http://web.mit.edu/tlo>



Fax

To:	U.S. Patent and Trademark Office	From:	Maureen Joyce, Patent Docket Manager
Fax:	(571) 273-8300	Pages:	3
Phone:	(571) 272-1000	Date:	01/14/2010
Re:	Change of Correspondence Address	cc:	

Urgent For Review Please Comment Please Reply Please Recycle

• **Comments:** Attached is an updated Fee Address Indication Form and corresponding 3.73(b) Form for patent number 7,314,033. Please update at your earliest convenience.

Thank you!

Page 1 of 3