



US006311214B1

(12) **United States Patent**  
**Rhoads**

(10) **Patent No.:** **US 6,311,214 B1**  
(45) **Date of Patent:** **\*Oct. 30, 2001**

(54) **LINKING OF COMPUTERS BASED ON OPTICAL SENSING OF DIGITAL DATA**

(75) Inventor: **Geoffrey B. Rhoads**, West Linn, OR (US)

(73) Assignee: **Digimarc Corporation**, Tualatin, OR (US)

(\* ) Notice: Subject to any disclaimer, the term of this patent is extended or adjusted under 35 U.S.C. 154(b) by 0 days.

This patent is subject to a terminal disclaimer.

(21) Appl. No.: **09/342,689**

(22) Filed: **Jun. 29, 1999**

**Related U.S. Application Data**

(63) Continuation-in-part of application No. 09/130,624, filed on Aug. 6, 1998, which is a continuation of application No. 08/508,083, filed on Jul. 27, 1995, now Pat. No. 5,841,978, and a continuation-in-part of application No. 09/314,648, filed on May 19, 1999, which is a continuation-in-part of application No. 09/292,569, filed on Apr. 15, 1999.

(60) Provisional application No. 60/134,782, filed on May 19, 1999.

(51) **Int. Cl.<sup>7</sup>** ..... **G06F 13/00**

(52) **U.S. Cl.** ..... **709/217; 709/313; 380/4**

(58) **Field of Search** ..... **709/217, 219, 709/227, 230, 250, 313, 328, 329; 380/4, 9, 49**

(56) **References Cited**

**U.S. PATENT DOCUMENTS**

4,947,028 8/1990 Gorog .

5,053,956 10/1991 Donald et al. .  
5,262,860 11/1993 Fitzpatrick et al. .  
5,288,976 2/1994 Citron et al. .  
5,385,371 1/1995 Izawa .  
5,463,209 10/1995 Figh et al. .  
5,495,581 2/1996 Tsai .

(List continued on next page.)

**FOREIGN PATENT DOCUMENTS**

0493091 7/1992 (EP) .  
WO95/14289 5/1995 (WO) .  
WO95/20291 7/1995 (WO) .  
WO96/27259 9/1996 (WO) .  
WO96/36163 11/1996 (WO) .  
WO97/02522 1/1997 (WO) .  
WO97/43736 11/1997 (WO) .  
WO98/03923 1/1998 (WO) .  
WO98/51036 11/1998 (WO) .  
WO99/57623 11/1999 (WO) .

**OTHER PUBLICATIONS**

U.S. application No. 60/000,442, Hudetz, filed Jun. 22, 1995.

(List continued on next page.)

*Primary Examiner*—Viet D. Vu

(74) *Attorney, Agent, or Firm*—William Y. Conwell; Digimarc Corporation

(57) **ABSTRACT**

A printed object, such as an item of postal mail, a book, printed advertising, a business card, product packaging, etc., is steganographically encoded with plural-bit data. When such an object is presented to an optical sensor, the plural-bit data is decoded and used to establish a link to an internet address corresponding to that object.

**23 Claims, 2 Drawing Sheets**

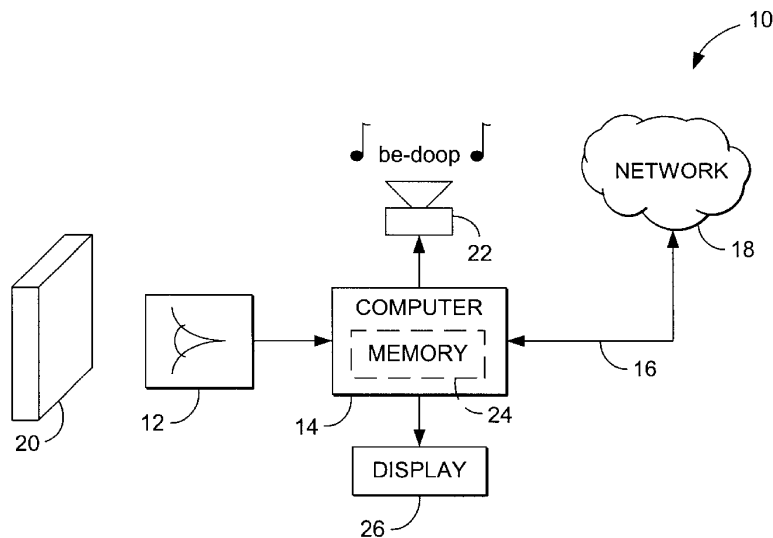

## U.S. PATENT DOCUMENTS

5,496,071	3/1996	Walsh .	
5,530,852	6/1996	Meske, Jr. et al. .	
5,613,004	3/1997	Cooperman et al. .	
5,640,193	6/1997	Wellner .	
5,659,164	8/1997	Schmid et al. .	
5,673,316	9/1997	Auerbach et al. .	
5,721,788	2/1998	Powell et al. .	
5,742,845	4/1998	Wagner .	
5,761,606	6/1998	Wolzien .	
5,761,686	6/1998	Bloomberg .	
5,774,664	6/1998	Hidary et al. .	
5,774,666	6/1998	Portuesi .	
5,778,102	7/1998	Sandford, II et al. .	
5,804,803	9/1998	Cragun et al. .	
5,809,317	9/1998	Kogan et al. .	
5,818,441	10/1998	Throckmorton et al. .	
5,822,432	10/1998	Moskowitz et al. .	
5,838,458	11/1998	Tsai .	
5,848,413	* 12/1998	Wolff .....	707/10
5,857,038	1/1999	Owada et al. .	
5,872,589	2/1999	Morales .	
5,892,900	4/1999	Ginter et al. .	
5,900,608	5/1999	Iida .	
5,903,729	5/1999	Reber et al. .	
5,905,248	* 5/1999	Russell et al. ....	235/462.27
5,913,210	6/1999	Call .	
5,915,027	6/1999	Cox et al. .	
5,918,214	6/1999	Perkowski .	
5,932,863	8/1999	Rathus et al. .	
5,933,829	8/1999	Durst et al. .	
5,938,726	8/1999	Reber et al. .	
5,940,595	8/1999	Reber et al. .	
5,978,773	11/1999	Hudetz et al. .	
5,986,651	11/1999	Reber et al. .	
6,012,102	1/2000	Shachar .	
6,052,486	4/2000	Knowlton et al. .	

6,081,827	6/2000	Reber et al. .
6,098,106	8/2000	Philyaw et al. .
6,108,656	8/2000	Durst et al. .
6,148,331	11/2000	Parry .

## OTHER PUBLICATIONS

IBM Technical Disclosure Bulletin 96A 61092, published Jan. 1, 1996.

"Distributing Uniform Resource Locators as Bar Code Images," IBM Technical Disclosure Bulletin, No. 39, No. 1, pp. 167-168, 96A 60059, published Jan. 1, 1996.

Frequently Asked Questions about Digimarc Signature Technology, Aug. 1, 1995, 9 pages.

Bartlett, et al., "An Overview of HighWater FBI Technology," Posted on Internet Mar. 22, 1996, 12 pages.

Digimarc presentation at RSA Conference, Jan. 1996, 4 pages.

"Digital Watermarks What Are They?" Digimarc Corporation, 1997.

Seybold Report on Internet Publishing, vol. 1, No. 4, Dec. 1996.

Seybold Report on Publishing Systems, vol. 25, No. 6, 1996.

Bethoney, "A Lasting Way For Artists To Leave Their Mark," PCWeek, Dec. 11, 1996.

Digital Media Monthly, Aug., 1996 (excerpt re Highwater FBI).

Digimarc Press Releases (various), 1996-1998.

Simone, "A Digita Watermark for Images," PC Magazine Dec. 18, 1996.

"Copyright Protection for Digital Images, Digital Fingerprinting from FBI," Highwater FBI brochure, 1995, 4 pages.

"Highwater FBI Limited Presentation, Image Copyright Protection Software," FBI Ltd brochure, Jul. 1995, 17 pages.

\* cited by examiner

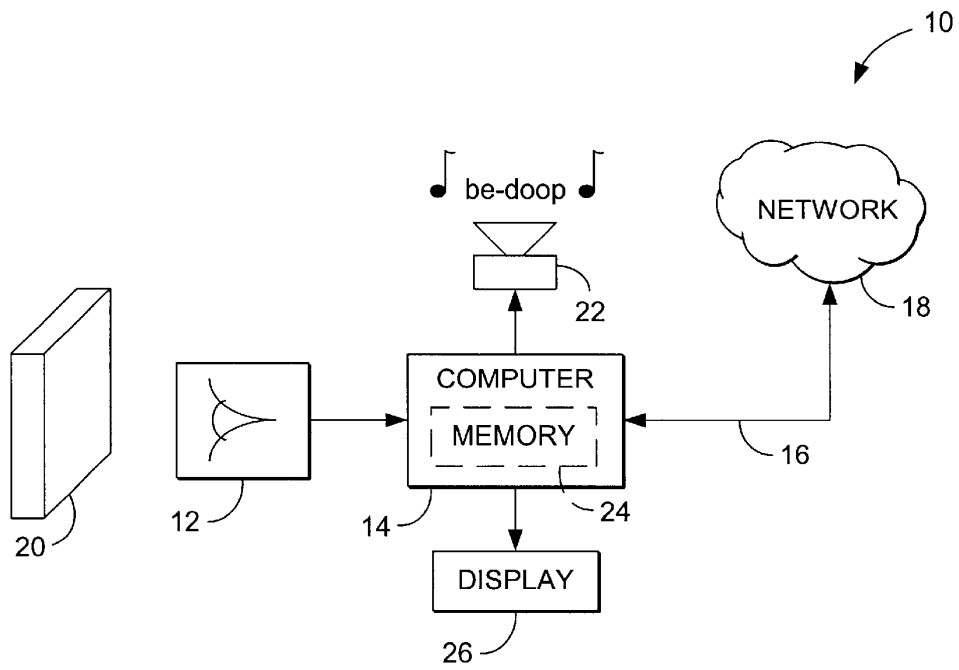

FIG. 1

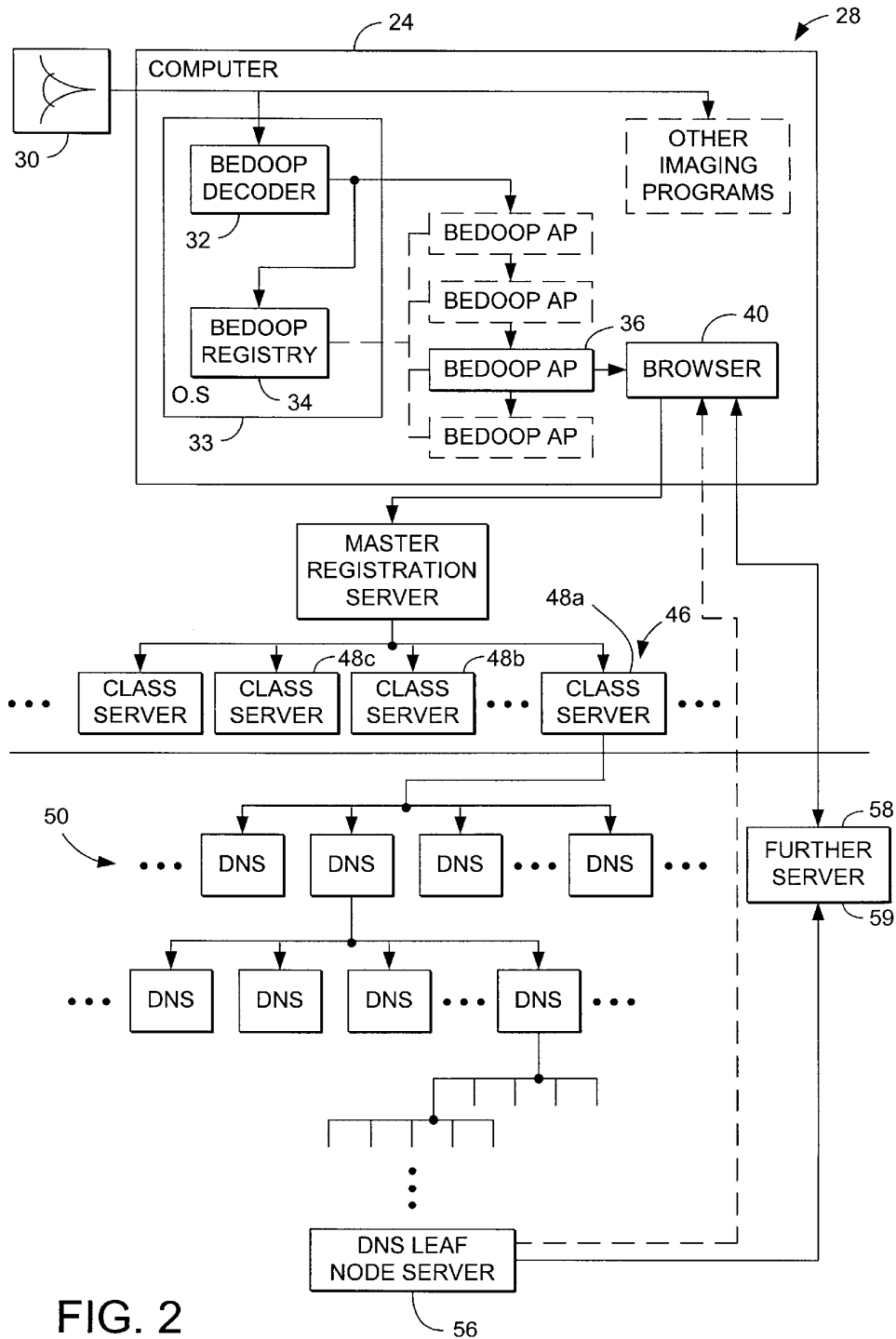

FIG. 2

## LINKING OF COMPUTERS BASED ON OPTICAL SENSING OF DIGITAL DATA

### RELATED APPLICATION DATA

This application is a continuation-in-part of copending application Ser. No. 09/130,624, filed Aug. 6, 1998, which is a continuation of application Ser. No. 08/508,083 filed on Jul. 27, 1995, (now U.S. Pat. No. 5,841,978). This application is also a continuation-in part of copending application Ser. No. 09/314,648, filed May 19, 1999 (attached as Appendix A). This application is also a continuation-in-part of copending provisional application 60/134,782, also filed May 19, 1999 (attached as Appendix B). This application is also a continuation-in-part of copending application Ser. No. 09/292,569, filed Apr. 15, 1999, which claims priority to application Ser. No. 60/082,228, filed Apr. 16, 1998.

### FIELD OF THE INVENTION

The present invention relates optical user interfaces that sense digitally-encoded objects. The invention further relates to systems using such optical interfaces to control computers, and to navigate over or act as portals on networks.

### BACKGROUND AND SUMMARY OF THE INVENTION

“Bedoop.” That might be the sound that someone might hear as they lazily place a magazine advertisement in front of their desktop camera. Magically, the marketing and sales web site associated with the ad is displayed on their computer. More information? Want to buy now? Look at the full product line? No problem.

“Bedoop.” That might be the same sound when that same someone places their credit card in front of their desktop camera. Instantly, the product displayed on the web page is purchased. Behind the scenes, a secure purchase link is initiated, transmitting all requisite information to the vendor. Twist the credit card clockwise and the purchaser chooses overnight delivery.

So goes an exemplary embodiment of the invention further described in this application. Though this example is rather specific, it nevertheless alludes to an indescribably vast array of applications possible when a digital camera or other optical sensing device is turned into a general purpose user interface device with an intuitive power that very well might rival the mouse and the keyboard.

The centerpiece of the invention is that an object or paper product so-scanned contains digital information that can be quickly read and acted upon by an appropriately configured device, computer or appliance. The preferred embodiment envisions that this digital information is aesthetically hidden on objects. These objects have been previously and proactively marked with the digital information, using any of the broad ranges of printing and processing techniques which are available on the market and which are widely described in the open literature and patent literature surrounding digital watermarking.

Be this as it may, though the invention concentrates on flat object applications wherein the digital information is often imperceptibly integrated into the object, it is certainly not meant to be so limited. Objects can be three dimensional in nature and the information more visually overt and/or pre-existing (i.e., not “pro-actively” embedded, or not even be “digital,” per se). Different implementation considerations attach to these variants. Likewise, though the bulk of this

disclosure concentrates on objects which have some form of digital message attached thereto, some aspects of the invention may apply to objects which have no such thing, where the prior arts of pattern recognition and gestural input can be borrowed in combination with this invention to effect yet a broader array of applications.

“Bedoop.” The sound that a refrigerator might make, outfitted with a simple camera/processor unit/net connection, as the ten year old holds up the empty milk carton and a ping goes out to the local grocery store, adding the item to an accumulating delivery list. The sound that might be heard echoing over and over inside Internet cafes as heretofore computerphobes take their first skeptical steps onto the world wide web. The sound heard at the fast food counter as the repeat customer holds up their sandwich card ticking off their latest meal, hoping for the sirens to go off for a \$500 prize given to the lucky customer of the week. Blue sky scenarios abound.

This invention is therefore about powerful new user interfaces to computers involving optical input. These new user interfaces extend into the everyday world in ways that a mouse and keyboard never could. By enabling everyday objects to communicate their identities and functions to ever-attendant devices, not only will the world wide web be given an entirely new dimension, but basic home and office computing may be in store for some fundamental advances as well.

These and a great many other features of the present invention will be more readily apparent from the following detailed description, which proceeds with reference to the accompanying drawings.

### BRIEF DESCRIPTION OF THE DRAWINGS

FIG. 1 is a block diagram showing one embodiment of the present invention.

FIG. 2 is another block diagram showing an embodiment of the present invention.

### DETAILED DESCRIPTION

Basically, the technology detailed in this disclosure may be regarded as enhanced systems by which users can interact with computer-based devices. Their simple nature, and adaptability for use with everyday objects (e.g., milk cartons), makes the disclosed technology well suited for countless applications.

Due to the great range and variety of subject matter detailed in this disclosure, an orderly presentation is difficult to achieve. As will be evident, many of the topical sections presented below are both founded on, and foundational to, other sections. For want of a better rationale, the sections are presented below in a more or less random order. It should be recognized that both the general principles and the particular details from each section find application in other sections as well. To prevent the length of this disclosure from ballooning out of control, the various permutations and combinations of the features of the different sections are not exhaustively detailed. The inventors intend to explicitly teach such combinations/permutations, but practicality requires that the detailed synthesis be left to those who ultimately implement systems in accordance with such teachings.

#### Basic Principles—Refrigerators and Clutter

Referring to FIG. 1, a basic embodiment 10 of the present invention includes an optical sensor 12, a computer 14, and a network connection 16 to the internet 18. The illustrated optical sensor 12 is a digital camera having a resolution of

# Explore Litigation Insights

Docket Alarm provides insights to develop a more informed litigation strategy and the peace of mind of knowing you're on top of things.

## Real-Time Litigation Alerts



Keep your litigation team up-to-date with **real-time alerts** and advanced team management tools built for the enterprise, all while greatly reducing PACER spend.

Our comprehensive service means we can handle Federal, State, and Administrative courts across the country.

## Advanced Docket Research



With over 230 million records, Docket Alarm's cloud-native docket research platform finds what other services can't. Coverage includes Federal, State, plus PTAB, TTAB, ITC and NLRB decisions, all in one place.

Identify arguments that have been successful in the past with full text, pinpoint searching. Link to case law cited within any court document via Fastcase.

## Analytics At Your Fingertips



Learn what happened the last time a particular judge, opposing counsel or company faced cases similar to yours.

Advanced out-of-the-box PTAB and TTAB analytics are always at your fingertips.

## API

Docket Alarm offers a powerful API (application programming interface) to developers that want to integrate case filings into their apps.

## LAW FIRMS

Build custom dashboards for your attorneys and clients with live data direct from the court.

Automate many repetitive legal tasks like conflict checks, document management, and marketing.

## FINANCIAL INSTITUTIONS

Litigation and bankruptcy checks for companies and debtors.

## E-DISCOVERY AND LEGAL VENDORS

Sync your system to PACER to automate legal marketing.