



[54] **METHOD FOR TRAFFIC MANAGEMENT, TRAFFIC PRIORITIZATION, ACCESS CONTROL, AND PACKET FORWARDING IN A DATAGRAM COMPUTER NETWORK**

[75] Inventors: **David R. Cheriton; Andreas V. Bechtolsheim**, both of Palo Alto, Calif.

[73] Assignee: **Cisco Systems, Inc.**, San Jose, Calif.

[\*] Notice: This patent issued on a continued prosecution application filed under 37 CFR 1.53(d), and is subject to the twenty year patent term provisions of 35 U.S.C. 154(a)(2).

[21] Appl. No.: **08/581,134**

[22] Filed: **Dec. 29, 1995**

[51] **Int. Cl.<sup>7</sup>** ..... **H04L 12/56**

[52] **U.S. Cl.** ..... **370/392; 370/397; 370/400**

[58] **Field of Search** ..... 370/230, 231, 370/235, 236, 237, 395, 392, 397, 401, 402, 403, 412, 399, 407, 400

[56] **References Cited**

**U.S. PATENT DOCUMENTS**

Re. 33,900 4/1992 Howson .  
4,131,767 12/1978 Weinstein .

(List continued on next page.)

**FOREIGN PATENT DOCUMENTS**

0 384 758 2/1990 European Pat. Off. .  
0 384 758 A2 8/1990 European Pat. Off. .  
0 431 751 A1 11/1990 European Pat. Off. .  
0 567 217 A2 10/1993 European Pat. Off. .  
WO93/07569 4/1993 WIPO .  
WO93/07692 4/1993 WIPO .  
WO94/01828 1/1994 WIPO .  
WO 95/20850 8/1995 WIPO .  
WO95/20850 8/1995 WIPO .

**OTHER PUBLICATIONS**

William Stallings, Data and Computer Communications, PP: 329-333, Prentice Hall, Upper Saddle River, New Jersey 07458.

Allen, M., "Novell IPX Over Various WAN Media (IPXW AN)," Network Working Group, RFC 1551, Dec. 1993, pp. 1-22.

(List continued on next page.)

*Primary Examiner*—Min Jung  
*Attorney, Agent, or Firm*—Oblon, Spivak, McClelland, Maier & Neustadt, P.C.

[57] **ABSTRACT**

The invention provides an enhanced datagram packet switched computer network. The invention processes network datagram packets in network devices as separate flows, based on the source-destination address pair in the datagram packet. As a result, the network can control and manage each flow of datagrams in a segregated fashion. The processing steps that can be specified for each flow include traffic management, flow control, packet forwarding, access control, and other network management functions. The ability to control network traffic on a per flow basis allows for the efficient handling of a wide range and a large variety of network traffic, as is typical in large-scale computer networks, including video and multimedia traffic. The amount of buffer resources and bandwidth resources assigned to each flow can be individually controlled by network management. In the dynamic operation of the network, these resources can be varied based on actual network traffic loading and congestion encountered. The invention also teaches an enhanced datagram packet switched computer network which can selectively control flows of datagram packets entering the network and traveling between network nodes. This new network access control method also interoperates with existing media access control protocols, such as used in the Ethernet or 802.3 local area network. An aspect of the invention is that it does not require any changes to existing network protocols or network applications.

**6 Claims, 6 Drawing Sheets**

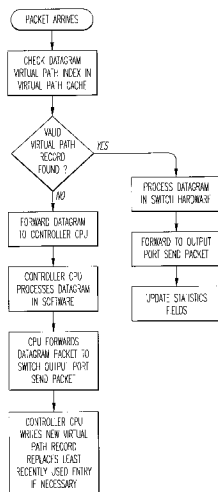

U.S. PATENT DOCUMENTS					
4,161,719	7/1979	Parikh et al. .	5,243,596	9/1993	Port et al. .
4,316,284	2/1982	Howson .	5,245,614	9/1993	Gutman et al. .... 370/477
4,397,020	8/1983	Howson .	5,247,516	9/1993	Bernstein et al. .
4,419,728	12/1983	Larson .	5,249,178	9/1993	Kurano et al. .
4,424,565	1/1984	Larson .	5,253,251	10/1993	Aramaki .
4,437,087	3/1984	Petr .	5,255,291	10/1993	Holden et al. .
4,438,511	3/1984	Baran .	5,260,933	11/1993	Rouse .
4,439,763	3/1984	Limb .	5,260,978	11/1993	Fleischer et al. .
4,445,213	4/1984	Baugh et al. .	5,268,592	12/1993	Bellamy et al. .
4,446,555	5/1984	Devault et al. .	5,268,900	12/1993	Hluchyj et al. .
4,456,957	6/1984	Schieltz .	5,271,004	12/1993	Proctor et al. .
4,464,658	8/1984	Thelen .	5,274,631	12/1993	Bhardwaj .
4,499,576	2/1985	Fraser .	5,274,635	12/1993	Rahman et al. .
4,506,358	3/1985	Montgomery .	5,274,643	12/1993	Fisk .
4,507,760	3/1985	Fraser .	5,280,470	1/1994	Buhrke et al. .
4,532,626	7/1985	Flores et al. .	5,280,480	1/1994	Pitt et al. .
4,644,532	2/1987	George et al. .	5,280,500	1/1994	Mazzola et al. .
4,646,287	2/1987	Larson et al. .	5,283,783	2/1994	Nguyen et al. .
4,677,423	6/1987	Benvenuto et al. .	5,287,103	2/1994	Kasprzyk et al. .
4,679,189	7/1987	Olson et al. .... 370/60	5,287,453	2/1994	Roberts ..... 395/200
4,679,227	7/1987	Hughes-Hartogs .	5,291,482	3/1994	McHarg et al. .
4,723,267	2/1988	Jones et al. .	5,305,311	4/1994	Lyles .
4,731,816	3/1988	Hughes-Hartogs .	5,307,343	4/1994	Bostica et al. .
4,750,136	6/1988	Arpin et al. .	5,309,437	5/1994	Perlman et al. .... 370/85.13
4,757,495	7/1988	Decker et al. .	5,311,509	5/1994	Heddes et al. .
4,763,191	8/1988	Gordon et al. .	5,313,454	5/1994	Bustini et al. .
4,769,810	9/1988	Eckberg, Jr. et al. .	5,313,582	5/1994	Hendel et al. .
4,769,811	9/1988	Eckberg, Jr. et al. .	5,317,562	5/1994	Nardin et al. .
4,771,425	9/1988	Baran et al. .	5,319,644	6/1994	Liang .
4,819,228	4/1989	Baran et al. .	5,327,421	7/1994	Hiller et al. .
4,827,411	5/1989	Arrowood et al. .	5,331,637	7/1994	Francis et al. .
4,833,706	5/1989	Hughes-Hartogs .	5,335,224	8/1994	Cole et al. .... 370/235
4,835,737	5/1989	Herrig et al. .	5,345,445	9/1994	Hiller et al. .
4,879,551	11/1989	Georgiou et al. .	5,345,446	9/1994	Hiller et al. .
4,893,306	1/1990	Chao et al. .	5,359,592	10/1994	Corbalis et al. .
4,903,261	2/1990	Baran et al. .	5,361,250	11/1994	Nguyen et al. .
4,922,486	5/1990	Lidinsky et al. .	5,361,256	11/1994	Doeringer et al. .
4,933,937	6/1990	Konishi .	5,361,259	11/1994	Hunt et al. .
4,960,310	10/1990	Cushing .	5,365,524	11/1994	Hiller et al. .
4,962,497	10/1990	Ferenc et al. .	5,367,517	11/1994	Cidon et al. .
4,962,532	10/1990	Kasirai et al. .	5,371,852	12/1994	Attanasio et al. .
4,965,772	10/1990	Daniel et al. .	5,386,567	1/1995	Lien et al. .
4,970,678	11/1990	Sladowski et al. .	5,390,170	2/1995	Sawant et al. .
4,979,118	12/1990	Kheradpir ..... 364/436	5,390,175	2/1995	Hiller et al. .
4,980,897	12/1990	Decker et al. .	5,394,394	2/1995	Crowther et al. .
4,991,169	2/1991	Davis et al. .	5,394,402	2/1995	Ross .
5,003,595	3/1991	Collins et al. .	5,400,325	3/1995	Chatwani et al. .
5,014,265	5/1991	Hahne et al. .	5,408,469	4/1995	Opher et al. .
5,020,058	5/1991	Holden et al. .	5,416,842	5/1995	Aziz .
5,033,076	7/1991	Jones et al. .	5,422,880	6/1995	Heitkamp et al. .
5,054,034	10/1991	Hughes-Hartogs .	5,422,882	6/1995	Hiller et al. .
5,059,925	10/1991	Weisbloom .	5,423,002	6/1995	Hart .
5,072,449	12/1991	Enns et al. .	5,426,636	6/1995	Hiller et al. .
5,088,032	2/1992	Bosack .	5,426,637	6/1995	Derby et al. .... 370/401
5,095,480	3/1992	Fenner ..... 370/94.1	5,428,607	6/1995	Hiller et al. .
5,115,431	5/1992	Williams et al. .	5,430,715	7/1995	Corbalis et al. .
5,128,945	7/1992	Enns et al. .	5,430,729	7/1995	Rahnema .
5,136,580	8/1992	Vidlock et al. .	5,432,784	7/1995	Ozveren ..... 370/235
5,166,930	11/1992	Bruff et al. .	5,442,457	8/1995	Najafi .
5,199,049	3/1993	Wilson .	5,442,630	8/1995	Gagliardi et al. .
5,206,886	4/1993	Bingham .	5,452,297	9/1995	Hiller et al. .
5,208,811	5/1993	Kashio et al. .	5,473,599	12/1995	Li et al. .
5,212,686	5/1993	Joy et al. .	5,473,607	12/1995	Hausman et al. .
5,224,099	6/1993	Corbalis et al. .	5,477,541	12/1995	White et al. .
5,226,120	7/1993	Brown et al. .	5,485,455	1/1996	Dobbins et al. .
5,228,062	7/1993	Bingham .	5,490,140	2/1996	Abensour et al. .
5,229,994	7/1993	Balzano et al. .	5,490,258	2/1996	Fenner ..... 395/401
5,237,564	8/1993	Lespagnol et al. .	5,491,687	2/1996	Christensen et al. .
5,241,682	8/1993	Bryant et al. .	5,491,804	2/1996	Heath et al. .
5,243,342	9/1993	Kattemalavadi et al. .	5,497,368	3/1996	Reijnierse et al. .
			5,499,238	3/1996	Shon ..... 370/399
			5,504,747	4/1996	Swasey .

5,509,006	4/1996	Wilford et al. .	
5,517,494	5/1996	Green .	
5,519,704	5/1996	Farinacci et al. .	
5,519,858	5/1996	Walton et al. ....	395/600
5,526,489	6/1996	Nilakantan et al. .	
5,530,963	6/1996	Moore et al. .	
5,535,195	7/1996	Lee .	
5,539,734	7/1996	Burwell et al. .	
5,541,911	7/1996	Nilakantan et al. .	
5,546,370	8/1996	Ishikawa .	
5,555,244	9/1996	Gupta et al. .	
5,561,669	10/1996	Lenney et al. .	
5,583,862	12/1996	Callon .	
5,592,470	1/1997	Rudrapatna et al. .	
5,598,581	1/1997	Daines et al. .	
5,600,798	2/1997	Chenrukuri et al. .	
5,604,868	2/1997	Komine et al. .	
5,608,726	3/1997	Virgile .	
5,617,417	4/1997	Sathe et al. .	
5,617,421	4/1997	Chin et al. .	
5,630,125	5/1997	Zellweger .....	395/614
5,632,021	5/1997	Jennings et al. .	
5,634,010	5/1997	Ciscon et al. .	
5,638,359	6/1997	Peltola et al. .	
5,644,718	7/1997	Belove et al. .	
5,659,684	8/1997	Giovanoni et al. .	
5,666,353	9/1997	Klausmeier et al. .	
5,673,265	9/1997	Gupta et al. .	
5,678,006	10/1997	Valizadeh et al. .	
5,680,116	10/1997	Hashimoto et al. .	
5,684,797	11/1997	Aznar et al. ....	370/390
5,689,506	11/1997	Chiussi et al. ....	370/388
5,694,390	12/1997	Yamato et al. .	
5,748,186	5/1998	Raman .....	345/302
5,748,617	5/1998	McLain, Jr. .	
5,802,054	9/1998	Bellenger .	
5,835,710	11/1998	Nagami et al. .	
5,856,981	1/1999	Voelker .	
5,892,924	4/1999	Lyon et al. ....	395/200.75
5,903,559	5/1999	Acharya et al. .	

## OTHER PUBLICATIONS

Becker, D., "3c589.c: A 3c589 Etherlink3 ethernet driver for linux," becker@CESDIS.gsfc.nasa.gov, May 3, 1994, pp. 1-13.

Chowdhury, et al., "Alternative Bandwidth Allocation Algorithms for Packet Video in ATM Networks," INFOCOM 1992, pp. 1061-1068.

Doeringer, W., "Routing on Longest-Matching Prefixes," IEEE/ACM Transactions in Networking, vol. 4, No. 1, Feb. 1996, pp. 86-97.

Esaki, et al., "Datagram Delivery in an ATM-Internet," 2334b IEICE Transactions on Communications, Mar. 1994, No. 3, Tokyo, Japan.

IBM Corporation, "Method and Apparatus for the Statistical Multiplexing of Voice, Data and Image Signals," IBM Technical Disclosure Bulletin, No. 6, Nov. 1992, pp. 409-411.

Pei, et al., "Putting Routing Tables in Silicon," IEEE Network Magazine, Jan. 1992, pp. 42-50.

Perkins, D., "Requirements for an Internet Standard Point-to-Point Protocol," Network Working Group, RFC 1547, Dec. 1993, pp. 1-19.

Simpson, W., "The Point-to-Point Protocol (PPP)," Network Working Group, RFC 1548, Dec. 1993, pp. 1-53.

Tsuchiya, P.F., "A Search Algorithm for Table Entries with Non-Contiguous Wildcarding," Abstract, Bellcore.

Zhang, et al., "Rate-Controlled Static-Priority Queueing," INFOCOM 1993, pp. 227-236.

Chowdhury, et al. "Alternative Bandwidth Allocation", 1992, IEEE Infocom '92, pp. 1061-1068.

Zhang, et al. "Rate-Controlled Static-Priority Queueing", 1993, IEEE, pp. 227-236.

IBM, "Method and Apparatus for the Statistical Multiplexing of Voice, Data, and Image Signals", Nov., 1992, IBM Technical Data Bulletin n6 Nov. 1992, pp. 409-411.

Esaki, et al., "Datagram Delivery in an ATM-Internet," IEICE Transactions on Communications vol. E77-B, No. 3, (1994) Mar., Tokyo, Japan.

Doeringer, et al., "Routing on Longest-Matching Prefixes," IEEE Transactions on Networking, vol. 4, No. 1, Feb. 1996, pp. 86-97.

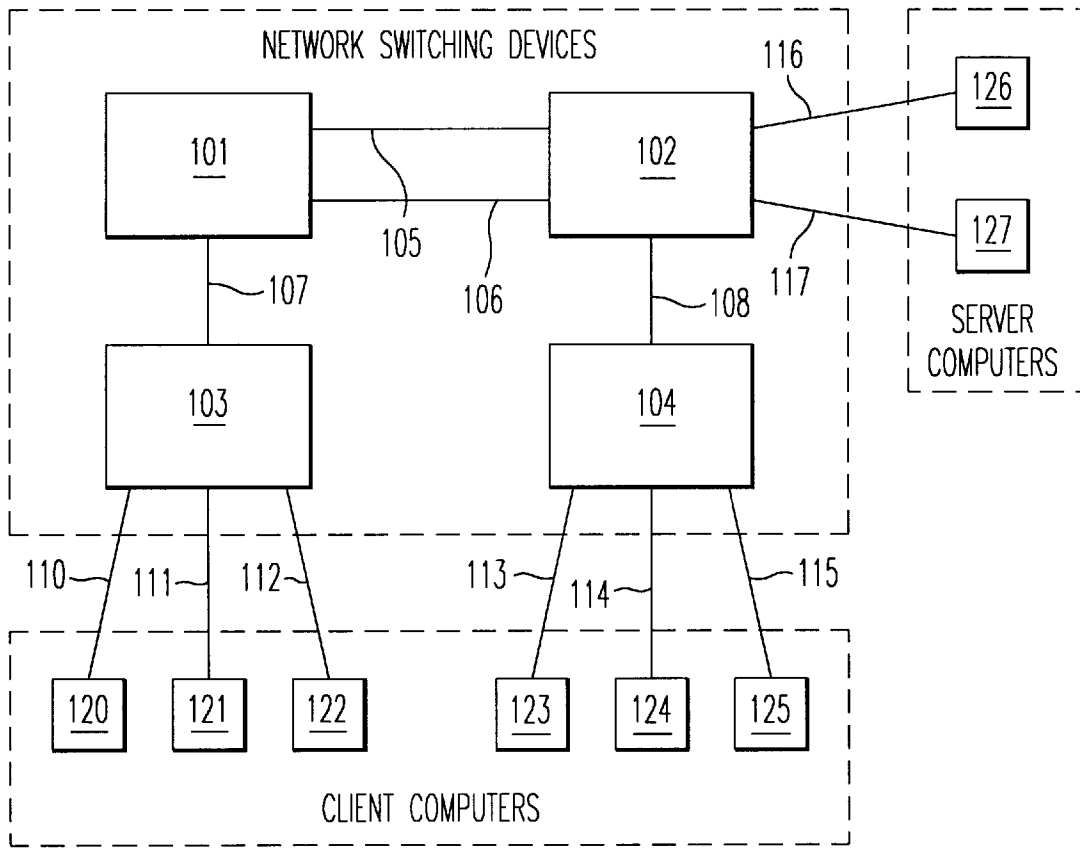

FIG. 1

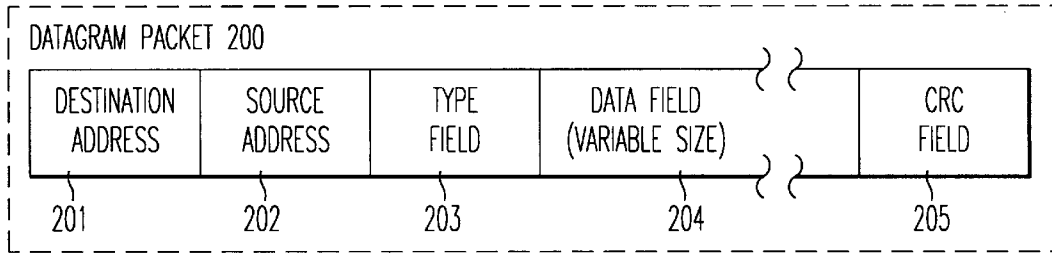

FIG. 2

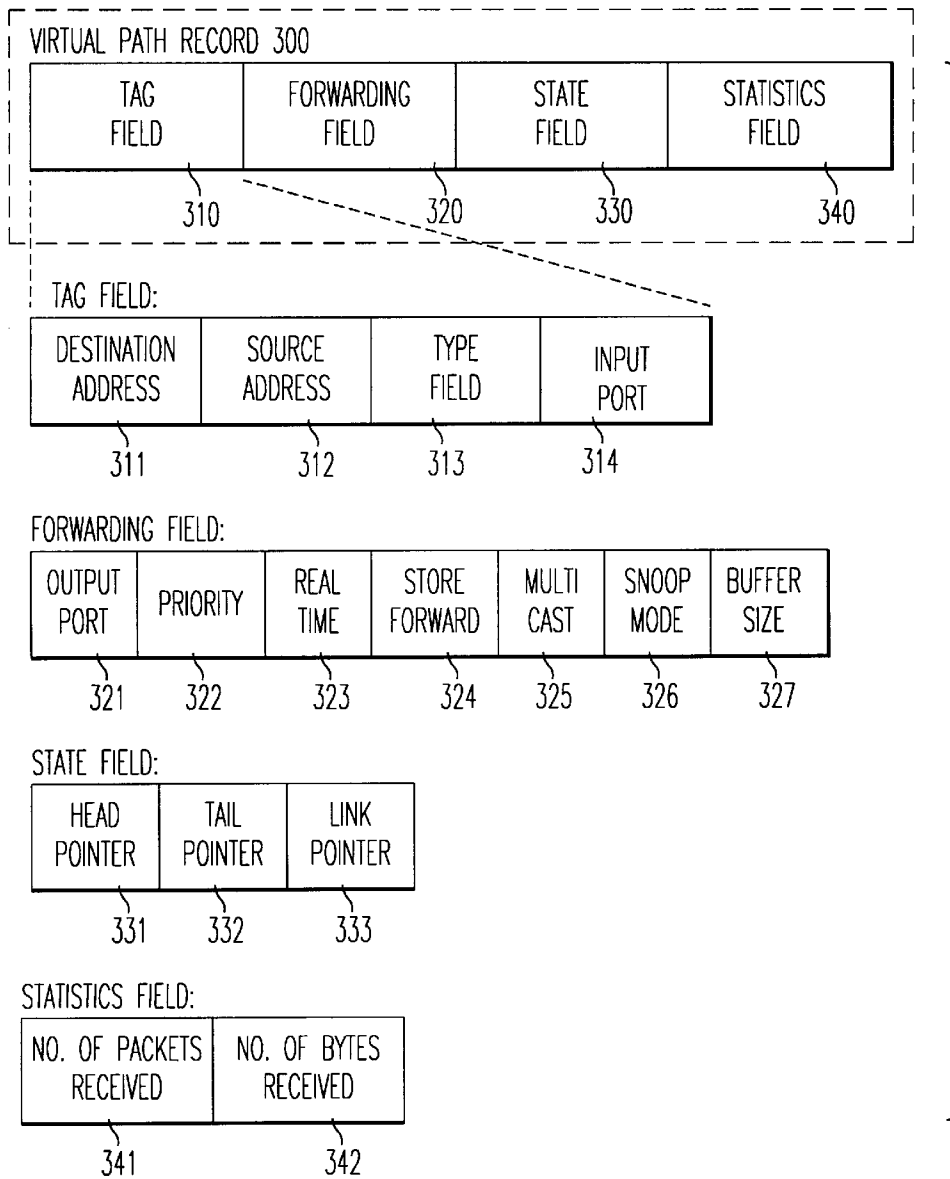

FIG. 3

# Explore Litigation Insights

Docket Alarm provides insights to develop a more informed litigation strategy and the peace of mind of knowing you're on top of things.

## Real-Time Litigation Alerts



Keep your litigation team up-to-date with **real-time alerts** and advanced team management tools built for the enterprise, all while greatly reducing PACER spend.

Our comprehensive service means we can handle Federal, State, and Administrative courts across the country.

## Advanced Docket Research



With over 230 million records, Docket Alarm's cloud-native docket research platform finds what other services can't. Coverage includes Federal, State, plus PTAB, TTAB, ITC and NLRB decisions, all in one place.

Identify arguments that have been successful in the past with full text, pinpoint searching. Link to case law cited within any court document via Fastcase.

## Analytics At Your Fingertips



Learn what happened the last time a particular judge, opposing counsel or company faced cases similar to yours.

Advanced out-of-the-box PTAB and TTAB analytics are always at your fingertips.

## API

Docket Alarm offers a powerful API (application programming interface) to developers that want to integrate case filings into their apps.

## LAW FIRMS

Build custom dashboards for your attorneys and clients with live data direct from the court.

Automate many repetitive legal tasks like conflict checks, document management, and marketing.

## FINANCIAL INSTITUTIONS

Litigation and bankruptcy checks for companies and debtors.

## E-DISCOVERY AND LEGAL VENDORS

Sync your system to PACER to automate legal marketing.