

generated by said video cameras and selected for storage.

372. Video data storage apparatus according to claim 370, wherein said third printed circuit board has mounted thereon an integrated circuit processing device for  
5 applying a moving image content analysis algorithm to said digitized fields of video information.

373. Video data storage apparatus according to claim 370, further comprising archive means, operatively connected to said microprocessor, for recording on a  
10 removable recording medium video data copied from said hard disk.

374. Video data storage apparatus, comprising:  
a video information source for outputting at least one stream of video data fields;  
15 storage means for storing said video data fields in the form of compressed video data;  
a housing;  
a motherboard mounted in said housing, said motherboard having mounted thereon a microprocessor for  
20 controlling storage of said compressed video data by said storage means;  
a second printed circuit board mounted in said housing and connected to said motherboard;  
a first digital signal processing integrated  
25 circuit (DSP-IC), mounted on said second printed circuit board, for exchanging data with said microprocessor and for applying a data compression algorithm to said at least one stream of video data fields; and  
at least one other DSP-IC mounted on said second  
30 printed circuit board, for processing said at least one stream of video data fields;  
said first DSP-IC transmitting command messages to, and receiving status messages from, said at least one other DSP-IC.

35 375. Video data storage apparatus according to claim 374, wherein:

said second printed circuit board has mounted thereon display processing circuitry for applying scaling

processing and overlay mixing to said at least one stream of video data fields; and

said at least one other DSP-IC mounted on said second printed circuit board includes:

5 a second DSP-IC for controlling said display processing circuitry, and

a third DSP-IC for applying a moving image content analysis algorithm to said at least one stream of video data fields.

10 376. Video data storage apparatus according to claim 375, wherein said data exchanged between said microprocessor and said first DSP-IC includes parameter data transmitted from said microprocessor to said first DSP-IC, said parameter data for constraining execution by  
15 said third DSP-IC of said moving image content analysis algorithm, said first DSP-IC transmitting said parameter data to said third DSP-IC.

377. Video data storage apparatus according to claim 374, said first DSP-IC comparing predetermined portions of  
20 said video data fields with corresponding portions of a reference video data field to determine whether said predetermined portions are to be stored by said storage means.

378. Video data storage apparatus according to claim  
25 377, further including a JPEG integrated circuit, mounted on said second printed circuit board, for applying video data compression processing, in accordance with the JPEG compression standard to said reference video data field and to said predetermined portions of video data fields  
30 which said first DSP-IC determines are to be stored by said storage means.

379. Video data storage apparatus according to claim 374, wherein said storage means includes a hard disk within said housing.

35 380. A printed circuit board for a video data storage apparatus, the printed circuit board having means for receiving at least one stream of video data fields and having mounted thereon:

a first digital signal processing integrated circuit (DSP-IC) for applying a data compression algorithm to said at least one stream of video data fields;

5 a second DSP-IC for controlling scaling and overlay mixing processes applied to said at least one stream of video data fields; and

a third DSP-IC for applying a moving image content analysis algorithm to said at least one stream of video data fields.

10 381. A printed circuit board according to claim 380, wherein said first DSP-IC transmits command messages to, and receives status messages from, each of said second and third DSP-IC's.

15 382. A printed circuit board according to claim 381, wherein said first DSP-IC exchanges data with a microprocessor not located on said printed circuit board.

383. A structure for supporting a plurality of recording medium drive units in a video data storage apparatus, the structure comprising:

20 a base member for supporting at least one of said drive units;

a second member, supported on said base member, for supporting at least a second one of said drive units; and

25 a third member, supported on said second member, for securing said at least second one of said drive units on said second member.

30 384. A structure according to claim 383, wherein said third member is shaped and sized to support at least a third one of said plurality of drive units.

385. A structure according to claim 384, wherein each of said base member, said second member and said third member is shaped and sized to support at least two of said drive units.

35 386. A structure according to claim 385, wherein each of said second member and said third member is shaped and sized to support two standard hard disk drive units.

387. A structure according to claim 383, wherein said

base member includes a substantially planar and horizontal bottom plate and two vertical end walls emerging upwardly and integrally from respective opposite side edges of said bottom plate.

5           388. A structure according to claim 387, wherein said second member is substantially planar.

          389. A structure according to claim 388, wherein one of said vertical end walls of said base member has a pair of slots formed therein, and said second member has a pair  
10 of hinge-tabs formed thereon at respective positions that correspond to respective positions of said slots on said base member, each of said hinge-tabs for pivotally engaging a respective one of said slots.

          390. A structure according to claim 389, wherein each  
15 of said base member, said second member and said third member has a respective attachment tab formed thereon, each of the attachment tabs having a hole formed therein for accommodating a fastener, said base member, said second member and said third member being positioned with  
20 respect to each other so that the three holes in the attachment tabs are aligned to permit simultaneous insertion of the fastener through all three holes.

          391. A structure according to claim 388, wherein said second member has a pad mounted on a lower surface of said  
25 second member, said pad for pressing against a drive unit supported on said base member.

          392. A structure according to claim 391, wherein said third member includes a substantially planar and horizontal top plate and two vertical end walls emerging  
30 downwardly and integrally from respective opposite side edges of said top plate.

          393. A structure according to claim 392, wherein said top plate of said third member has a pad mounted on a lower surface of said top plate, said pad on said top  
35 plate for pressing against a drive unit supported on said second member.

          394. A multiple record medium drive unit assembly for use in a video data storage apparatus, the assembly

comprising:

a base member;

a pair of record medium drive units mounted on said base member;

5 a second support member positioned above said drive units and supported on said base member;

a third record medium drive unit mounted on said second support member;

10 a third support member supported on said second support member; and

means for securing said base member, said second support member and said third support member to each other.

15 395. An assembly according to claim 394, further comprising a fourth record medium drive unit supported on said second support member.

396. An assembly according to claim 395, further comprising a fifth record medium drive unit supported on said third support member.

20 397. An assembly according to claim 396, further comprising a sixth recording medium drive unit supported on said third support member.

25 398. An assembly according to claim 394, further comprising a fourth record medium drive unit supported on said third support member.

399. An assembly according to claim 394, wherein one of said pair of drive units mounted on said base member is for driving a removable recording medium.

30 400. An assembly according to claim 399, wherein said other one of said pair of drive units is a floppy disk drive and the third drive unit is a hard disk drive.

401. An assembly according to claim 400, wherein said removable recording medium is a digital audio tape.

35 402. An assembly according to claim 400, wherein said removable recording medium is a DVD.

403. An assembly according to claim 400, wherein said removable recording medium is a writable optical disk.

404. An assembly according to claim 400, wherein said

removable recording medium is a magneto-optical disk.

405. A video data storage apparatus, comprising:  
source means for providing video data;  
first storage means including a first  
5 storage medium for storing said video data provided by  
said source means;

second storage means including a second  
storage medium on which video data provided by said source  
means has been recorded;

10 third storage means including a third  
storage medium for storing video data to be archived; and  
control means for controlling said first  
storage means to store said video data provided by said  
source means, while controlling said second and third  
15 storage means to transfer said video data recorded on said  
second storage medium from said second storage medium to  
said third storage medium.

406. Apparatus according to claim 405, wherein said  
first storage medium is a first hard disk, said second  
20 storage medium is a second hard disk, and said third  
storage medium is a magnetic tape.

407. Apparatus according to claim 406, wherein said  
third storage means is a helical-scan tape recorder.

408. Apparatus according to claim 407, wherein said  
25 third storage means records said video data to be archived  
on said third storage medium in accordance with a standard  
format for digital audio tape recording.

409. Apparatus according to claim 405, wherein said  
source means includes a plurality of video cameras, each  
30 generating a respective sequence of frames of video  
signals, and conversion means for converting the  
respective sequences of frames of video signals into  
respective sequences of frames of digital video data.

410. Apparatus according to claim 409, further  
35 comprising index generating means for generating, with  
respect to the frames of digital video data, index data  
indicative of respective times at which the frames of  
digital video data were generated, the ones of the

plurality of cameras which generated the frames of digital video data, and locations on said first storage medium at which said frames of digital video data are recorded.

411. Apparatus according to claim 410, wherein said  
5 index data generated by said index data generating means further includes data indicative of events represented by the sequences of frames of digital video data.

412. Apparatus according to claim 410, further  
10 comprising means for receiving signals indicative of alarm conditions, and wherein said index data generated by said index data generating means further includes data indicative of said alarm conditions.

413. Apparatus according to claim 410, further  
15 comprising fourth storage means including a fourth storage medium for storing said index data generated by said index data generating means.

414. Apparatus according to claim 413, wherein said fourth storage medium is a hard disk.

415. Apparatus according to claim 413, wherein said  
20 control means controls said fourth storage means to read out said index data from said fourth storage medium.

416. Apparatus according to claim 415, wherein said  
25 control means controls said third storage means to record on said third storage medium the index data read out from said fourth storage medium.

417. Apparatus according to claim 413, wherein said  
control means controls said first storage means to record on said first storage medium the index data generated by said index data generating means.

30 418. Apparatus according to claim 405, wherein said control means determines what portion of said first storage medium remains available for storing said video data provided by said source means and determines what quantity of the video data recorded on said second storage  
35 medium remains to be transferred to said third storage medium, said control means comparing said available proportion of said first storage medium and said quantity of video data remaining to be transferred from said second

storage medium, and said control means selecting, on the basis of a result of said comparison, a storage rate at which said first storage means stores on said first storage medium said video data provided by said source means.

419. Apparatus according to claim 418, wherein said storage rate selected by said control means is a frame rate at which said first storage means stores on said first storage medium frames of said video data provided by said source means.

420. A method of archiving video data stored in a video data storage apparatus, the apparatus including a plurality of video cameras, first and second video data storage hard disks, an index data storage hard disk, an archive recording medium and a drive unit for the archive recording medium, the method comprising the steps of:

(a) storing on said first video data storage hard disk video data representative of dynamic video signal streams generated by said video cameras, while storing on said index data storage hard disk index data indicative of times of recording and sources of the video data being stored on said first video data storage hard disk;

(b) concurrently with step (a), recording on said archive recording medium all video data stored on said second video data storage hard disk and index data stored on said index data storage hard disk and indicative of times of recording and sources of the video data stored on said second video data storage hard disk; and

(c) after completion of step (b),  
(i) storing on said second video data storage hard disk video data representative of dynamic video signal streams generated by said video cameras; and  
(ii) concurrently with step (c)(i), recording on said archive recording medium index data



5 stored on said index data storage hard disk and indicative of times of recording and sources of the video data stored on said first video data storage hard disk during step (a) and also storing on said archive recording medium said video data stored on said first video data storage hard disk during step (a).

10 421. A method according to claim 420, wherein step (c) is performed immediately upon completion of step (b).

15 422. A method according to claim 420, wherein step (c) is deferred after completion of step (b), until a predetermined quantity of video data has been stored on said first video data storage hard disk.

20 423. An apparatus for storing and retrieving video data, comprising:

a plurality of video cameras generating respective sequences of video signals;

a first hard disk for selectively storing video data corresponding to the video signals generated by said video cameras, and for selectively outputting the video data stored on said first hard disk;

25 a second hard disk for selectively storing video data corresponding to the video signals generated by said video cameras, and for selectively outputting the video data stored on said second hard disk;

30 an archive medium drive unit for selectively recording on an archive recording medium video data stored on and outputted from said first and second hard disks;

35 display means for selectively displaying an image corresponding to video data stored on and outputted from said first and second hard disks; and

control means for controlling said first and second hard disks, said archive medium drive unit and

said display means, said control means selectively performing recording operations in which video data corresponding to the video signals generated by said video cameras is recorded on a selected one of said hard disks, 5 playback operations in which said display means displays an image corresponding to video data read from a selected one of said hard disks, and archiving operations in which video data outputted from a selected one of said hard disks is recorded on said archive recording medium, at 10 least some of said recording, playback and archiving operations exhibiting dynamic variations in a quantity of video data involved in said operations, said control means having a finite processing capacity and allocating its said processing capacity so as to give priority to said 15 recording operations relative to said playback operations and so as to give priority to said playback operations relative to said archiving operations.

424. Apparatus according to claim 423, wherein said archive medium drive unit operates in accordance with a 20 standard digital audio tape (DAT) format.

425. Apparatus according to claim 423, wherein said archive medium drive unit is selected from a group consisting of a writable optical disk drive, a DVD drive, a magneto-optical disk drive, and a removable hard disk 25 drive.

426. A video data storage apparatus, comprising:  
video information source means for providing a sequence of frames of video data;  
primary storage means including a storage 30 medium for storing video data provided by said video information source means;  
archive storage means for storing video data to be archived; and  
control means for controlling said primary 35 storage means to store said video data provided by said video information source means at a storage rate selected by said control means, said control means also controlling said primary storage means and said archive storage means

to transfer to said archive storage means video data stored by said primary storage means, said control means calculating a first time for completion of transferring of a predetermined quantity of stored video data from said primary storage means to said archive storage means, and calculating a second time for completion of storing on said primary storage means of a predetermined number of fields of video data to be provided by said video information source means, said control means comparing said calculated first and second times and, on the basis of a result of said comparison, selecting said storage rate at which said primary storage means stores said video data provided by said video information source means.

427. Apparatus according to claim 426, wherein, if said first time is earlier than said second time, said control means selects a first field rate at which said primary storage means stores said video data provided by said video information source means, and if said second time is earlier than said first time, said control means selects a second field rate at which said primary storage means stores said video data provided by said video information source means, said second field rate being slower than said first field rate.

428. Apparatus according to claim 426, wherein said primary storage means includes a first storage medium on which video data currently provided by said video information source means is being stored and a second storage medium from which previously stored video data is currently being transferred to said archive storage means.

429. Apparatus according to claim 428, wherein said first storage medium is a first hard disk, said second storage medium is a second hard disk, and said archive storage means includes a magnetic recording tape on which is recorded the video data transferred from said second hard disk.

430. Video information storage apparatus, comprising:  
a plurality of video cameras each for generating a respective stream of video information;

a housing;

storage means fixedly mounted in said housing for storing the streams of video information;

archive means for driving a recording medium  
5 that is removable from said housing, said archive means being operated to copy onto a sequence of removable recording media video information sequentially stored on said storage means; and

means for generating removable media data and  
10 for recording said removable media data on said storage means, said removable media data including data corresponding to each of a plurality of said removable recording media upon which said video information was copied, said data corresponding to each removable  
15 recording medium including data indicative of the video cameras by which and the times at which the video information copied on the recording medium was generated.

431. Video information storage apparatus according to claim 430, wherein said storage means includes a first  
20 hard disk and a second hard disk, said video information being stored on, and copied onto said removable media from, said first hard disk, and said removable media data being recorded on said second hard disk.

432. Video information storage apparatus according to  
25 claim 430, wherein said storage means includes a hard disk on which said removable media data is recorded and from which said video information is copied onto said removable media.

433. Video information storage apparatus according to  
30 claim 430, wherein said archive means includes a digital audio tape deck.

434. A closed-circuit video surveillance system, comprising:

a plurality of video cameras;

35 selection means for selecting one or more of said video cameras;

display means for displaying video images generated by ones of said video cameras selected by said

selection means; and

control means for controlling said display means, said control means causing said display means to display a plurality of symbols each representative of a  
5 respective one of said video cameras, said control means also causing said display means to display an indication in association with at least one of said symbols to indicate that the camera or cameras corresponding to said  
at least one of said symbols have been selected by said  
10 selection means.

435. A closed-circuit video surveillance system according to claim 434, wherein said control means causes said display means to display the video images generated by the selected video camera or cameras in a first portion  
15 of a display screen and to display said symbols representative of said plurality of video cameras in a second portion of said display screen.

436. A closed-circuit video surveillance system according to claim 435, wherein said symbols  
20 representative of said plurality of video cameras are buttons on which a cursor is selectively positioned to select corresponding ones of said video cameras.

437. A closed-circuit video surveillance system according to claim 436, wherein said second portion of  
25 said display screen is displaced downwardly from said first position of said display screen.

438. A method of indicating a display status of video cameras selected for display from among a plurality of video cameras included in a closed-circuit video  
30 surveillance system, the method comprising the steps of:

displaying in a window on a display screen images generated by one or more of said cameras, said one or more of said cameras having been selected for display;

displaying, outside of said window on said  
35 display screen, a plurality of symbols each corresponding to a respective one of said plurality of video cameras included in said closed-circuit video surveillance system; and

displaying one or more indicia for indicating which one or ones of said plurality of video cameras have been selected for display, each of said one or more indicia being displayed in proximity to one of said symbols which corresponds to a video camera selected for display.

439. A closed-circuit video surveillance system, comprising:

a plurality of video cameras;

display-selection means for display-selecting one or more of said video cameras;

display means including a display screen for displaying respective streams of video images generated by ones of said video cameras display-selected by said display-selection means, each respective displayed stream of video images being displayed in a respective display window on said display screen;

record-selection means for record-selecting one or more of said video cameras;

recording means for recording video information corresponding to the video images generated by ones of said video cameras record-selected by said record-selection means; and

control means for controlling said display means, said control means causing said display means to display a record-enable indicia at a border of each said display window, said record-enable indicia for indicating whether the display-selected video camera corresponding to the respective display window is currently record-selected by said record selection means.

440. A closed-circuit video surveillance system according to claim 439, wherein said display means simultaneously displays in respective display windows the video image streams generated by a plurality of display-selected cameras, said display means simultaneously displaying a respective record-enable indicia at a respective border of each of said simultaneously-displayed display windows.

441. A closed-circuit video surveillance system according to claim 440, wherein said display means simultaneously displays four display windows each corresponding to a respective display-selected video  
5 camera.

442. A closed-circuit video surveillance system according to claim 441, wherein said display means simultaneously displays nine display windows each corresponding to a respective display-selected video  
10 camera.

443. A closed-circuit video surveillance system according to claim 439, wherein said recording means records the video information corresponding to the video images generated by each of said record-selected video  
15 cameras according to a respective selected one of a plurality of recording modes, said plurality of recording modes including a first recording mode in which images generated by the respective record-selected camera are continuously recorded at intervals that do not exceed a  
20 maximum interval, and a second recording mode in which images generated by the respective record-selected camera are only recorded in response to detection of an alarm condition, the record-enable indicia displayed for each video camera that is both record- and display-selected  
25 being displayed in a first state when the first recording mode is currently selected for the respective video camera, and being displayed in a second state different from the first state when the second recording mode is currently selected for the respective video camera.

444. A closed-circuit video surveillance system according to claim 439, wherein said recording means includes at least one hard disk on which is recorded the video information corresponding to the video images generated by said record-selected video cameras.  
30

445. A method of indicating a recording status with respect to video cameras included in a closed-circuit video surveillance system, the method comprising the steps of:  
35

displaying in a window on a display screen a dynamic image generated by one of said video cameras;

displaying at a border of said window a record-  
enable indicia to indicate whether signals output by said  
5 one of said video cameras have been selected for  
recording.

446. A method according to claim 445, further  
comprising the step of simultaneously displaying, in  
respective windows, a plurality of image streams each  
10 generated by a respective one of said video cameras, each  
of said windows having a border at which a respective  
record-enable indicia is provided to indicate whether  
signals of the respective video camera have been selected  
for recording.

15 447. In a closed-circuit video surveillance system  
including a video camera, a method of automatically  
diagnosing the video camera, comprising the steps of:

storing a reference image generated by the video  
camera;

20 analyzing the stored reference image to form  
reference parameters indicative of characteristics of the  
stored reference image;

storing the reference parameters;

25 automatically and periodically operating the  
video camera to generate comparison images;

storing and analyzing the comparison images to  
generate comparison parameters indicative of  
characteristics of the respective comparison images; and

30 comparing the comparison parameters with the  
stored reference parameters;

at least one of said comparison images being  
generated at least five days after said reference image  
was stored.

448. A method according to claim 447, wherein at  
35 least one of said comparison images is generated at least  
100 days after said reference image was stored.

449. A method according to claim 447, wherein said  
reference parameters include a color histogram and a



spatial frequency distribution.

450. A method according to step 447, wherein said step of periodically operating the video camera to generate said comparison images is performed weekly.

5 451. Apparatus for automatically diagnosing a video camera included in a closed-circuit video surveillance system, the apparatus comprising:

means for storing a reference image generated by the video camera;

10 means for analyzing the stored reference image to form reference parameters indicative of characteristics of the stored reference image;

means for storing the reference parameters;

calendar means for generating calendar signals;

15 diagnosis operation means, responsive to said calendar signals, for automatically and periodically operating the video camera to generate comparison images;

20 means for storing and analyzing the comparison images to generate comparison parameters indicative of characteristics of the respective comparison images; and

means for comparing the comparison parameters with the stored reference parameters;

25 said diagnosis operation means causing said video camera to generate at least one of said comparison images at least five days after said reference image was stored.

30 452. A method of displaying status information relating to a video surveillance system, the system including at least one hard disk for storing in digital form video image information generated by a plurality of video cameras, the system further including an archive storage device for driving a removable recording medium and copying video image information onto the removable recording medium from the hard disk, the method comprising  
35 the steps of:

displaying on a display screen first information indicative of unused recording space available on said at least one hard disk; and

displaying on said display screen second information indicative of unused recording space available on said removable recording medium.

453. A method according to claim 452, wherein said  
5 first and second information is displayed in the form of numeric characters.

454. A method according to claim 452, wherein said first and second information is displayed in the form of first and second graphic display elements, respectively.

10 455. A method according to claim 452, further comprising the step of displaying additional information indicative of a number of alarm events with respect to which alarm information has been stored in said video surveillance system, and said alarm information has been  
15 reviewed, within a predetermined period of time.

456. A method according to claim 452, further comprising the step of displaying additional information indicative of a number of alarm events with respect to which alarm information has been stored in said video  
20 surveillance system, and said alarm information has not been reviewed.

457. A method according to claim 452, further comprising the steps of:

25 displaying first additional information indicative of how many video cameras are connected to said video surveillance system; and

30 displaying second additional information indicative of a number of said video cameras which are currently selected for recording by said video surveillance system.

458. A method according to claim 452, wherein said video surveillance system includes means for selecting one of a plurality of display configurations in which one or more streams of video images, each generated by a  
35 respective video camera, are displayed in respective windows on said display screen, the method further comprising:

displaying additional information indicative of

the one of said plurality of display configurations which is currently selected by said means for selecting.

459. A video surveillance system, comprising:

a plurality of video cameras;

5 at least one hard disk for storing in digital form video image information generated by said video cameras;

archive means for driving a removable recording medium;

10 means for copying video image information from said hard disk onto said removable recording medium; and  
a display screen for displaying first information indicative of unused recording space available on said at least one hard disk, and for displaying second  
15 information indicative of unused recording space available on said removable recording medium.

460. A video surveillance system according to claim 459, wherein said display screen displays said first and second information in the form of numeric characters.

20 461. A video surveillance system according to claim 459, wherein said display screen displays said first and second information in the form of first and second graphic display elements, respectively.

462. Video data storage apparatus for simultaneously  
25 recording a plurality of streams of video images each generated by a respective video camera, comprising:

a plurality of video cameras;

a housing having a front panel;

30 storage means disposed within the housing for storing video information generated by the video cameras;

display means including a display screen for displaying the video information generated by the video cameras;

35 control means disposed within the housing for receiving the video information generated by the video cameras and transmitting the video information to the storage means and to the display means;

a plurality of manually-operable switches,

mounted in a layout pattern on the front panel of the housing, for inputting respective command signals to the control means; and

5 cursor means for transmitting signals to the control means to control positioning of a cursor on said display screen;

10 wherein the control means controls the display means to display a plurality of switch areas on the display screen in accordance with the switch layout pattern on the front panel, each of said switch areas on the display screen corresponding to one of the switches on the front panel and being actuatable by the cursor means to generate a command signal which is the same as the command signal generated by actuation of the corresponding  
15 switch on the front panel.

463. Video data storage apparatus according to claim 462, wherein said switches on the front panel include camera selection switches, each corresponding to one of said video cameras, for selecting the respective video  
20 camera so that the video information generated by the camera is displayed by the display means, said switch areas on the display screen including camera switch areas corresponding to said camera selection switches on the front panel.

25 464. Video data storage apparatus according to claim 463, wherein said switches on the front panel include a circular jog-shuttle switch manually rotatable by a user to generate command signals for controlling playback and display of video information stored by the storage means,  
30 said switch areas on the display screen including a circular switch area corresponding to the jog-shuttle switch on the front panel, said circular switch area having a control point actuatable by the cursor means for controlling playback and display of the video information  
35 stored by the storage means.

465. Video data storage apparatus according to claim 463, further comprising a plurality of light-emitting diodes (LEDs) mounted on the front panel, each adjacent to

a respective one of said camera selection switches, for indicating that the respective video camera is selected for display, and said display screen displaying adjacent to each of said camera switch areas a camera selection  
5 indication corresponding to a respective one of the LEDs on the front panel.

466. Video data storage apparatus according to claim 462, wherein said switches on the front panel include a circular jog-shuttle switch manually rotatable by a user  
10 to generate command signals for controlling playback and display of video information stored by the storage means, said switch areas on the display screen including a circular switch area corresponding to the jog-shuttle switch on the front panel, said circular switch area  
15 having a control point actuatable by the cursor means for controlling playback and display of the video information stored by the storage means.

467. A method of processing fields of video data, comprising the steps of:  
20 dividing each of said fields of video data into a plurality of rectangular data blocks, each said data block consisting of an  $n \times m$  array of picture elements, where  $n$  and  $m$  are positive integers greater than 1;  
comparing each said data block with a  
25 corresponding data block in a preceding field to generate comparison data;  
performing a data compression algorithm with respect to said data blocks on the basis of said comparison data; and  
30 performing a data analysis algorithm with respect to said data blocks on the basis of said comparison data.

468. A method according to claim 467, wherein said step of performing a data compression algorithm includes  
35 applying an orthogonal transform to said data blocks to produce coefficient data, and quantizing said coefficient data.

469. A method according to claim 467, wherein said

step of performing said data analysis algorithm includes detecting moving objects represented by said fields of video data.

470. A method according to claim 467, wherein  $n = m$   
5 = 8.

471. Video information storage and analysis apparatus, comprising:

video information source means for generating a dynamic sequence of video data frames;

10 compression means for applying a data compression algorithm to said dynamic sequence of video data frames to form compressed video data;

display means for displaying a dynamic image which corresponds to said dynamic sequence of video data  
15 frames;

analysis means for receiving said dynamic sequence of video data frames and performing a moving image content analysis algorithm with respect to the received dynamic sequence of video data frames; and

20 signal transmission means for simultaneously transmitting said dynamic sequence of video data frames from said video information source means to all three of said compression means, said display means and said analysis means.

25 472. Apparatus according to claim 471, wherein said video information source means includes a video camera.

473. Apparatus according to claim 472, wherein said video camera generates a dynamic analog video signal, and said video information source means further includes  
30 conversion means for converting said dynamic analog video signal into said dynamic sequence of video data frames.

474. Apparatus according to claim 471, wherein said compression means applies an orthogonal transform to said dynamic sequence of video data frames.

35 475. Apparatus according to claim 471, further comprising storage means for receiving and storing said compressed video data formed by said compression means.

476. Apparatus according to claim 475, wherein said

storage means includes a hard disk.

477. Apparatus according to claim 471, wherein said display means includes an NTSC monitor.

478. Apparatus according to claim 471, wherein said  
5 display means includes an SVGA monitor.

479. Apparatus according to claim 471, wherein said display means includes an NTSC monitor and an SVGA monitor.

480. Apparatus for storing video data, comprising:  
10 a plurality of source means each for providing a respective stream of video signals;

difference means for detecting differences between successive frames in each of said streams of video signals and for generating difference data indicative of  
15 the detected differences;

compression means for processing said difference data to form compression-encoded data representative of said streams of video signals; and

storage means for storing said compression-  
20 encoded data formed by said compression means.

481. Apparatus according to claim 480, further comprising analysis means for processing said difference data in accordance with a moving image content analysis algorithm to form analysis data indicative of respective  
25 characteristics of said streams of video signals.

482. Apparatus according to claim 481, wherein said storage means also stores said analysis data formed by said analysis means.

483. Apparatus according to claim 480, wherein said  
30 difference means includes means for storing data indicative of at least one frame of each of said streams of video signals.

484. Apparatus according to claim 483, wherein said difference means further includes comparison means for  
35 comparing data representative of an incoming frame of said streams of video signals with said stored data indicative of at least one frame of a corresponding one of said streams of video signals.

485. Apparatus for storing video data, comprising:  
a plurality of source means each for providing  
a respective stream of video signals;

5 difference means for detecting differences  
between successive frames in each of said streams of video  
signals and for generating difference data indicative of  
the detected differences;

analysis means for processing said difference  
data in accordance with a moving image content analysis  
10 algorithm to form analysis data indicative of respective  
characteristics of said streams of video signals; and

storage means for storing said analysis data  
formed by said analysis means.

486. Apparatus according to claim 485, wherein said  
15 difference means includes means for storing data  
indicative of at least one field of each of said streams  
of video signals.

487. Apparatus according to claim 486, wherein said  
difference means further includes comparison means for  
20 comparing data representative of an incoming field of said  
streams of video signals with said stored data indicative  
of at least one field of a corresponding one of said  
streams of video signals.

488. Apparatus for storing and displaying video  
25 information, comprising:

a first video camera for generating first video  
information;

a second video camera for generating second  
video information;

30 recording means for recording, on a first  
occasion, first and second video information  
simultaneously generated by said first and second video  
cameras on said first occasion;

storage means for storing the recorded first and  
35 second video information;

means for retrieving from said storage means and  
displaying, on a second occasion later in time than said  
first occasion, the first video information generated on



said first occasion by said first video camera;

selection means actuatable by a user of the apparatus on said second occasion for selecting said second video camera while said first video information  
5 generated on said first occasion by said first camera is being displayed;

search means, responsive to selection of said second video camera by said selection means while said first video information generated on said first occasion  
10 by said first video camera is being displayed, for searching said storage means to locate said second video information generated by said second video camera on said first occasion and stored on said storage means; and

means for displaying the located second video  
15 information.

489. Apparatus according to claim 488, further comprising a housing in which said storage means is enclosed, said housing including a front panel;

said selection means including a button, located  
20 on said front panel and corresponding to said second video camera.

490. Apparatus according to claim 489, wherein said means for retrieving and displaying includes a display screen on which is displayed said first video information  
25 generated by said first video camera on said first occasion, said display screen displaying simultaneously with said first video information a selection area corresponding to said second video camera, said selection means including means for positioning a cursor on said  
30 selection area to actuate said selection means to select said second video camera.

491. Apparatus according to claim 488, wherein said means for retrieving and displaying includes a display screen on which is displayed said first video information  
35 generated by said first video camera on said first occasion, said display screen displaying simultaneously with said first video information a selection area corresponding to said second video camera, said selection

means including means for positioning a cursor on said selection area to actuate said selection means to select said second video camera.

492. Apparatus according to claim 488, wherein said  
5 storage means includes a hard disk.

493. Apparatus according to claim 492, wherein said recording means records both said first video information and said second video information on said hard disk on said first occasion.

10 494. A method of retrieving and displaying video information, comprising the steps of:

displaying first video information, said first video information having been generated by a first video camera and stored on a recording medium on a first  
15 occasion prior to a time at which said displaying step is being performed;

while said displaying step is being performed, selecting a second video camera;

20 in response to said selection of said second video camera, automatically retrieving second video information generated by said second video camera and stored on a recording medium on said first occasion; and

displaying said retrieved second video information.

25 495. A method according to claim 494, wherein said selecting step includes actuating a switch located on a front panel of a video information storage device.

496. A method according to claim 495, wherein said selecting step includes positioning a cursor in a  
30 selection location displayed on a display screen.

497. A method of analyzing video information, comprising the steps of:

receiving an analog video signal which represents a dynamic sequence of images;

35 digitizing the received analog video signal to form a sequence of digitized video data fields which represent the dynamic sequence of images;

transmitting on a video bus the sequence of

digitized video data fields according to a timing sequence which includes a vertical blanking interval between each two adjacent video data fields;

receiving the sequence of digitized video data  
5 fields which were transmitted according to said timing sequence; and

applying a moving image content analysis  
algorithm to each received video data field during the  
vertical blanking interval which follows receipt of the  
10 video data field.

498. A method according to claim 497, wherein said  
transmitting step includes transmitting on said video bus  
video data corresponding to lines of each of said  
digitized video data fields, interspersed with data  
15 corresponding to two-dimensional pixel blocks of the  
respective digitized video data field.

499. Video information analysis apparatus,  
comprising:

means for receiving an analog video signal which  
20 represents a dynamic sequence of images;

means for digitizing the received analog video  
signal to form a sequence of digitized video data fields  
which represent the dynamic sequence of images;

a multi-bit parallel data bus;

25 transmission means for transmitting on said data  
bus the sequence of digitized video data fields formed by  
said means for digitizing, said transmission means  
transmitting the sequence of digitized video data fields  
according to a timing sequence which includes a vertical  
30 blanking interval between each two adjacent video data  
fields;

means for receiving the sequence of digitized  
video data fields which were transmitted on said data bus  
according to said timing sequence; and

35 means for applying a moving image content  
analysis algorithm to each received video data field  
during the vertical blanking interval which follows  
receipt of the video data field.

500. Video information analysis apparatus according to claim 499, wherein said transmission means transmits on said data bus video data corresponding to lines of each of said digitized video data fields, interspersed with video data corresponding to two-dimensional pixel blocks of the  
5 respective digitized video data field.

501. Apparatus for storing and analyzing video information, comprising:

10 a video camera for generating a sequence of video fields;

means for comparing predetermined portions of a present field of said sequence of video fields with a reference field of said sequence of video fields to form comparison statistics, said reference field having  
15 preceded the present field in said sequence of video fields;

compression means for comparing said comparison statistics with a first threshold, and for selectively discarding said predetermined portions of the present  
20 field on the basis of the comparing of the comparison statistics with the first threshold;

storage means for storing the predetermined portions of the present field which were not discarded by said compression means; and

25 analysis means for comparing said comparison statistics with a second threshold, different from said first threshold, to generate analysis statistics, and for analyzing the sequence of video fields, on the basis of said analysis statistics, to detect moving objects  
30 represented by said sequence of video fields.

502. Apparatus according to claim 501, wherein said storage means stores data indicative of results of the analysis performed by said analysis means.

503. Apparatus according to claim 501, wherein said  
35 predetermined portions of the present field are  $m \times n$  groups of pixels of the present field, where  $m$  and  $n$  are integers greater than one.

504. Apparatus according to claim 503, wherein  $m = n$

= 8.

505. Apparatus according to claim 501, further comprising JPEG means for applying to said predetermined portions of the present field not discarded by said  
5 compression means a data compression algorithm in accordance with the JPEG standard, to form transform-encoded video data to be stored by said storage means.

506. A method of storing and analyzing video information, comprising:

10           generating a sequence of video fields;  
              comparing predetermined portions of a present field of said sequence of video fields with a reference field of said sequence of video fields to form comparison statistics, said reference field having preceded the  
15 present field in said sequence of video fields;  
              comparing said comparison statistics with a first threshold and selectively discarding said predetermined portions of the present field on the basis of the comparing of the comparison statistics with the  
20 first threshold;  
              storing the predetermined portions of the present field which were not discarded;  
              comparing the comparison statistics with a second threshold, different from said first threshold; and  
25           analyzing the sequence of video fields, on the basis of said analysis statistics, to detect moving objects represented by said sequence of video fields.

507. A method according to claim 506, further comprising the steps of storing data indicative of results  
30 of the analysis performed by said analysis means.

508. A method according to claim 506, further comprising the steps of applying to the predetermined portions of the present field which were not discarded a data compression algorithm in accordance with the JPEG  
35 standard.

509. Video information storage apparatus, comprising:  
              a video camera for generating a first stream of dynamic images;

a record medium drive unit including a record medium for storing data representing said first stream of dynamic images, data representing a second stream of dynamic images having previously been stored on said  
5 record medium;

display means for displaying a selected one of said first stream of images and said second stream of images; and

control means for controlling said record medium  
10 drive unit and said display means so that data representing said first stream of dynamic images is being recorded on said record medium while said second stream of dynamic images is simultaneously played back from said record medium and displayed by said display means.

15 510. Video information storage apparatus according to claim 509, wherein said second stream of dynamic images was generated by said video camera which generates said first stream of dynamic images.

20 511. Video information storage apparatus according to claim 509, wherein said second stream of dynamic images was generated by a second video camera different from the video camera which generates said first stream of dynamic images.

25 512. Video information storage apparatus according to claim 509, wherein data representing a third stream of dynamic images, different from said first and second streams, has been stored on said record medium, and further comprising output means for transmitting data reproduced from said record medium to a remote device;  
30 said control means controlling said record medium drive unit and said output means so that said data representing said third stream of dynamic images is reproduced from said record medium and transmitted to said remote device by said output means, simultaneously with said recording  
35 of said first stream of dynamic images and said displaying of said second stream of images.

513. Video information storage apparatus according to claim 509, further comprising archive means for receiving

video data reproduced by said record medium drive unit and for recording the received video data on a removable recording medium.

514. Video information storage apparatus according to  
5 claim 513, wherein said video data to be recorded on the removable recording medium is reproduced by said record medium drive unit simultaneously with said recording of said first stream of dynamic images and said displaying of said second stream of images.

10 515. Video information storage apparatus according to claim 509, wherein said record medium is selected from a group consisting of a hard disk, a DVD, a writable optical disk, and a magneto-optical disk.

516. A method of storing and displaying video images,  
15 comprising the steps of:

(a) generating a stream of dynamic images and storing on a hard disk data representative of said stream of dynamic images;

(b) after step (a), generating and storing on  
20 said hard disk another stream of dynamic images; and

(c) simultaneously with step (b), reproducing from said hard disk and displaying said stream of dynamic images generated and stored during step (a).

517. A method according to claim 516, further  
25 comprising the steps of:

(d) prior to step (b), generating and recording on said hard disk still another stream of dynamic images; and

(e) simultaneously with step (b), reproducing  
30 from said hard disk and transmitting to a remote device said stream of dynamic images generated and stored during step (d).

518. A method according to claim 516, further comprising the step of:

35 (d) simultaneously with step (b), storing on a removable recording medium video data reproduced from said hard disk.

519. A method of storing and retrieving video

information, comprising the steps of:

generating a first sequence of dynamic video images on a first occasion and recording the first sequence of video images on a recording medium;

5 generating a second sequence of dynamic video images on a second occasion that is later than said first occasion, and recording the second sequence of video images on the recording medium; and

10 simultaneously reproducing from the recording medium both the first and second sequences of video images.

520. A method according to claim 519, further comprising the step of simultaneously displaying both of the reproduced first and second sequences of video images.

15 521. A method according to claim 520, wherein the reproduced first and second sequences of video images are displayed in respective display windows on the same display screen.

20 522. A method according to claim 521, wherein the reproduced first and second sequences of video images are displayed on different respective display screens.

25 523. A method according to claim 519, wherein the first sequence of video images is generated using a first video camera, and the second sequence of video images is generated using a second video camera that is different from said first video camera.

524. A method according to claim 519, wherein both of the first and second sequences of video images are generated using the same video camera.

30 525. A method according to claim 519, wherein said recording medium is a hard disk.

526. Apparatus for recording and retrieving video information, comprising:

a recording medium;

35 first means for generating a first sequence of dynamic video images on a first occasion and recording the first sequence of video images on the recording medium;

second means for generating a second sequence of



dynamic video images on a second occasion that is later than said first occasion, and recording the second sequence of video images on the recording medium; and

5 third means for simultaneously reproducing from the recording medium both the first and second sequences of video images.

527. Apparatus according to claim 526, further comprising display means for simultaneously displaying both of the first and second sequences simultaneously reproduced by said third means.

528. Apparatus according to claim 527, wherein said display means includes a display screen on which the reproduced first and second sequences are displayed simultaneously in respective display windows.

529. Apparatus according to claim 527, wherein said display means includes a first display screen on which the reproduced first sequence of video images is displayed and a second display screen, separate from said first display screen, on which the reproduced second sequence of video images is displayed.

530. Apparatus according to claim 526, wherein said first means includes a first video camera which generates said first sequence of video images and said second means includes a second video camera which generates said second sequence of video images.

531. Apparatus according to claim 526, wherein a single video camera is used to generate both of said first and second sequences of video images.

532. Apparatus according to claim 526, wherein said recording medium is a hard disk.

533. A method of storing and retrieving video information, comprising the steps of:

35 storing on a recording medium a plurality of segments of video information, each segment of video information having been generated at a different respective period of time;

inputting a first parameter signal indicative of a first one of said periods of time;

displaying the segment of video information generated during the period of time indicated by the first parameter signal; and,

while performing said displaying step, inputting  
5 a second parameter signal indicative of a second one of said periods of time and also displaying the segment of video information generated during the period of time indicated by the second parameter signal.

534. A video information analysis apparatus,  
10 comprising:

storage means for storing a video information data base;

analysis means for analyzing video information in the data base in accordance with a  
15 predetermined analysis algorithm, said predetermined analysis algorithm for assigning to respective portions of said video information analysis scores each indicative of a degree to which the respective portion of said video information represents a predetermined analysis feature,  
20 each said analysis score being a value within a predetermined range of values comprising at least three values.

535. A video information analysis apparatus according to claim 534, wherein said range of values comprises at  
25 least eight values.

536. A video information analysis apparatus according to claim 535, wherein said range of values comprises at least one hundred values.

537. A video information analysis apparatus according  
30 to claim 534, further comprising:

selection means for selecting a specific one of said range of values; and

search means for identifying portions of said video information having analysis scores greater than  
35 or equal to said selected one of said range of values.

538. A video information storage apparatus, comprising:

means for receiving video information;

means for analyzing the received video information to detect a predetermined feature in the received video information, and for generating a detection signal indicative of the detected feature;

5 memory means for storing the received video information; and

means for storing the detection signal as an index signal in association with the stored video information.

10 539. Apparatus according to claim 538, wherein the memory means includes means for storing the received video information in the form of digital data.

540. Apparatus according to claim 539, wherein the stored video information is in the form of plural frames  
15 of video data, each frame of video data having header data stored in association with the frame of video data, and said index signal is included in said header data.

541. Apparatus according to claim 538, further comprising:

20 means for reading the stored index signal; and

means for retrieving from the memory means a selected portion of the stored video information in accordance with the index signal read by the means for  
25 reading.

542. A video information storage apparatus, comprising:

storage means for storing video information;

30 means for retrieving the stored video information from the storage means;

means for analyzing the retrieved video information to detect a predetermined feature in the retrieved video information, and for generating a  
35 detection signal indicative of the detected feature; and

means for transmitting the detection signal to the storage means to store the detection signal as an index signal in association with the stored video

information.

543. Apparatus according to claim 542, wherein the storage means includes means for storing the video information in the form of digital data.

5 544. Apparatus according to claim 543, wherein the stored video information is in the form of plural frames of video data, each frame of video data having header data stored in association with the frame of video data, and said index signal is included in said header data.

10 545. Apparatus according to claim 542, further comprising:

means for reading the stored index signal;

and

15 means for retrieving from the storage means a selected portion of the stored video information in accordance with the index signal read by the means for reading.

546. A method of operating an apparatus for storing and retrieving video data, the method comprising the steps  
20 of:

storing a plurality of frames of video data on a first hard disk;

25 storing index data on said first hard disk, said index data including data indicative of respective times at which said frames of video data were generated and respective locations on said first hard disk at which said frames of video data are stored; and

storing said index data on a second hard disk.

30 547. A method according to claim 546, further comprising the steps of searching for a desired frame of the video data stored on the first hard disk on the basis of index data read out from the second hard disk.

35 548. A method according to claim 546, further comprising the step of storing on said second hard disk a quantity of video data read out from said first hard disk.

549. A method according to claim 546, wherein said video data stored on said first hard disk includes video

data representative of respective streams of video signals generated by a plurality of cameras, and said index data stored on said first and second hard disks includes data indicative of respective cameras by which said frames of video data stored on said first hard disk were generated.

5 550. A method according to claim 546, wherein said index data stored on said first and second hard disks includes data indicative of characteristics of said video data stored on said first hard disk, said characteristics of said video data having been detected by applying a video data analysis algorithm to said video data.

10 551. A method according to claim 550, wherein said video data analysis algorithm was applied to said video data before said video data was stored on said first hard disk.

15 552. A method according to claim 550, wherein said video data analysis algorithm was applied to said video data after said video data was stored on said first hard disk.

20 553. A method according to claim 546, wherein said index data stored on said first and second hard disks includes data indicative of alarm conditions detected at times when respective portions of the video data stored on said first hard disk were generated.

25 554. A video data storage apparatus, comprising:  
a video data source for providing a dynamic stream of video data frames;

a data memory device for storing the dynamic stream of video data frames provided by the video data source; and

30 control means for designating a main portion of said data memory device, said main portion for recording said dynamic stream of video data frames at a first frame rate, said control means also designating a buffer portion of said data memory device, said buffer portion for recording said dynamic stream of video data frames at a second frame rate that is higher than said first frame rate.

555. A video data storage apparatus according to claim 554, wherein said data memory device comprises a hard disk.

556. A video data storage apparatus according to claim 554, further comprising detection means for detecting an alarm condition, and wherein said control means designates said buffer portion of said data memory device by maintaining a pointer indicative of where said buffer portion is located in said data memory device, and said control means responds to detection of said alarm condition by said detection means by changing a value of said pointer, whereby said buffer portion is moved to a new location in said data memory device.

557. A data storage medium on which is stored video data representing a plurality of video image frames, frame identification data indicative of respective times at which said video image frames were generated, and characteristic data indicative of respective characteristics of the video image frames represented by said video data, said respective characteristics having been detected by applying an image analysis algorithm to said video data.

558. A data storage medium according to claim 557, wherein said characteristic data includes first subdata indicative of a type of characteristic represented by said characteristic data, and second subdata indicative of a degree to which a respective video image frame exhibits said type of characteristic represented by said characteristic data.

559. A data storage medium according to claim 557, wherein said image analysis algorithm was applied to said video data before said video data was stored on the storage medium.

560. A data storage medium according to claim 557, wherein said image analysis algorithm was applied to said video data by reading said video data from the storage medium.

561. A data storage medium according to claim 557,

wherein said characteristic data includes first characteristic data generated by applying a first image analysis algorithm to said video data, and second characteristic data generated by applying a second image analysis algorithm, different from said first image analysis algorithm, to said video data.

562. A data storage medium according to claim 561, wherein said first image analysis algorithm was applied to said video data before said video data was stored on the storage medium, and said second image analysis algorithm was applied to said video data after reading said video data from the storage medium.

563. A data storage medium according to claim 557, on which is also stored data indicative of an alarm condition detected at a time at which at least one of said video image frames was generated.

564. A data storage medium according to claim 557, on which is also stored data indicative of audio signals generated at times when said video image frames were generated.

565. A data storage medium according to claim 557, wherein said video data represents respective streams of video image frames generated by a plurality of video cameras, and there is also stored on the storage medium data identifying the respective one of said plurality of video cameras which generated each of the video image frames.

566. A data storage medium according to claim 557, comprising a hard disk.

567. A data storage medium according to claim 557, comprising a magnetic tape.

568. A data storage medium according to claim 567, wherein said video data is recorded in a plurality of parallel oblique recording tracks on said magnetic tape.

569. A video information storage apparatus, comprising:

a video camera for generating a stream of dynamic images;

storage means for storing respective video data portions each of which represents an image from said stream of dynamic images, each said video data portion including header data;

5 means for moving the video camera to change a field of view of the video camera; and

control means for providing control signals to said means for moving to control movement of the video camera;

10 said control means being connected to said storage means to provide to said storage means signals indicative of times when said control means is causing said camera to be moved;

said storage means responding to said signals provided to said storage means from said control means, by including a motion signal in the header data included in the video data portions corresponding to images generated at said times when said camera is moved, said motion signal indicating that the respective image was taken by said camera when said camera was moving.

20 570. A video information storage apparatus according to claim 569, further comprising:

means for retrieving the stored video data portions from the storage means;

25 analysis means for analyzing the retrieved video data portions to detect a predetermined feature in the images represented by the retrieved video data portions, and for generating a detection signal indicative of the detected feature;

30 means for transmitting the detection signal to the storage means to store the detection signal as an index signal in association with the stored video data portions; and

35 inhibit means for reading the movement signal included in the header data of respective ones of the stored video data portions and for inhibiting the analysis means from analyzing the respective ones of the stored video data portions.



571. A video information storage apparatus according to claim 570, wherein said index signal is included in the header data corresponding to the stored video data portions with respect to which the predetermined feature  
5 was detected by the analysis means.

572. A video information storage apparatus according to claim 570, wherein the predetermined feature detected by said analysis means is a moving object represented by the stream of dynamic images.

10 573. A method of storing and indexing video information, comprising the steps of:

using a movable video camera to generate a stream of dynamic images;

15 storing video data representing the stream of dynamic images; and

storing indexing data in association with the stored video data, said stored indexing data including movement data indicating, as to each image represented by the stored video data, whether the respective image was  
20 generated at a time when the camera was being moved.

574. A method according to claim 573, further comprising the steps of:

reading the movement data; and

25 on the basis of the read movement data, selectively analyzing the stored video data to detect a predetermined feature represented by the stored video data.

575. A method of transmitting and displaying video information, comprising the steps of:

30 receiving a plurality of streams of video information each generated by a respective video camera;

transmitting said plural streams of video information to display means field by field; and

35 displaying each of said plural streams of video information in a respective display window on a display screen;

wherein said transmitting step includes appending, to each field of each of said plural streams of

video information, header data which includes data indicative of the one of said display windows in which the field is to be displayed.

576. A method according to claim 575, wherein the appended header data includes data for identifying the one of said video cameras which generated the field.

577. Apparatus for transmitting and displaying video information, comprising:

means for receiving a plurality of streams of video information each generated by a respective video camera;

display means for simultaneously displaying each of said plural streams of video information in a respective display window on a display screen;

means for appending, to each field of said received plural stream of video information, header data which includes data indicative of the one of said display windows in which the respective field is to be displayed; and

means for transmitting the received fields of video information, with the appended header data, to the display means.

578. Apparatus according to claim 577, wherein said means for transmitting includes a multi-bit parallel data bus.

579. Apparatus according to claim 577, wherein the appended header data includes data for identifying the one of said video cameras which generated the field.

580. Apparatus according to claim 577, wherein said display means simultaneously displays four video information streams in respective windows on said display screen.

581. Apparatus according to claim 580, wherein said display means simultaneously displays nine video information streams in respective windows on said display screen.

582. Apparatus according to claim 581, wherein said display means simultaneously displays sixteen video

information streams in respective windows on said display screen.

583. A method of storing video information, comprising the steps of:

5 recording plural fields of video data on a recording medium, each of said fields of video data representing a respective image;

10 recording on said recording medium, in association with each of said fields of video data, header data including data indicative of a source of the image represented by the respective field;

reproducing from the recording medium the recorded fields of video data;

15 processing at least one of the header data and the reproduced fields of video data to obtain a processing result; and

20 on the basis of said processing result, recording process result data on said recording medium in the header data for at least one of said reproduced fields of video data.

584. A method according to claim 583, wherein said processing step includes applying a moving image content analysis algorithm to the reproduced fields of video data.

25 585. A method according to claim 584, wherein said moving image content analysis algorithm is for detecting moving objects represented by the reproduced fields of video data, and said process result is data indicative of detection of a moving object.

30 586. A method according to claim 583, wherein said recording medium is a hard disk.

587. A method according to claim 583, wherein said header data includes data for identifying a camera which generated the respective field of video data, and data indicative of a time at which the field of video data was  
35 generated.

588. Apparatus for storing video data, comprising:  
means for recording plural fields of video data on a recording medium, each of said fields of video data

representing a respective image;

means for recording on said recording medium, in association with each of said fields of video data, header data including data indicative of a source of the image  
5 represented by the respective field;

means for reproducing from the recording medium the recorded fields of video data;

processing means for processing at least one of the header data and the reproduced fields of video data,  
10 to generate process result data; and

means, responsive to said processing means, for recording the process result data on said recording medium in the header data for at least one of said reproduced fields of video data.

15 589. Apparatus according to claim 588, wherein said processing means includes analysis means for applying a moving image content analysis algorithm to the reproduced fields of video data.

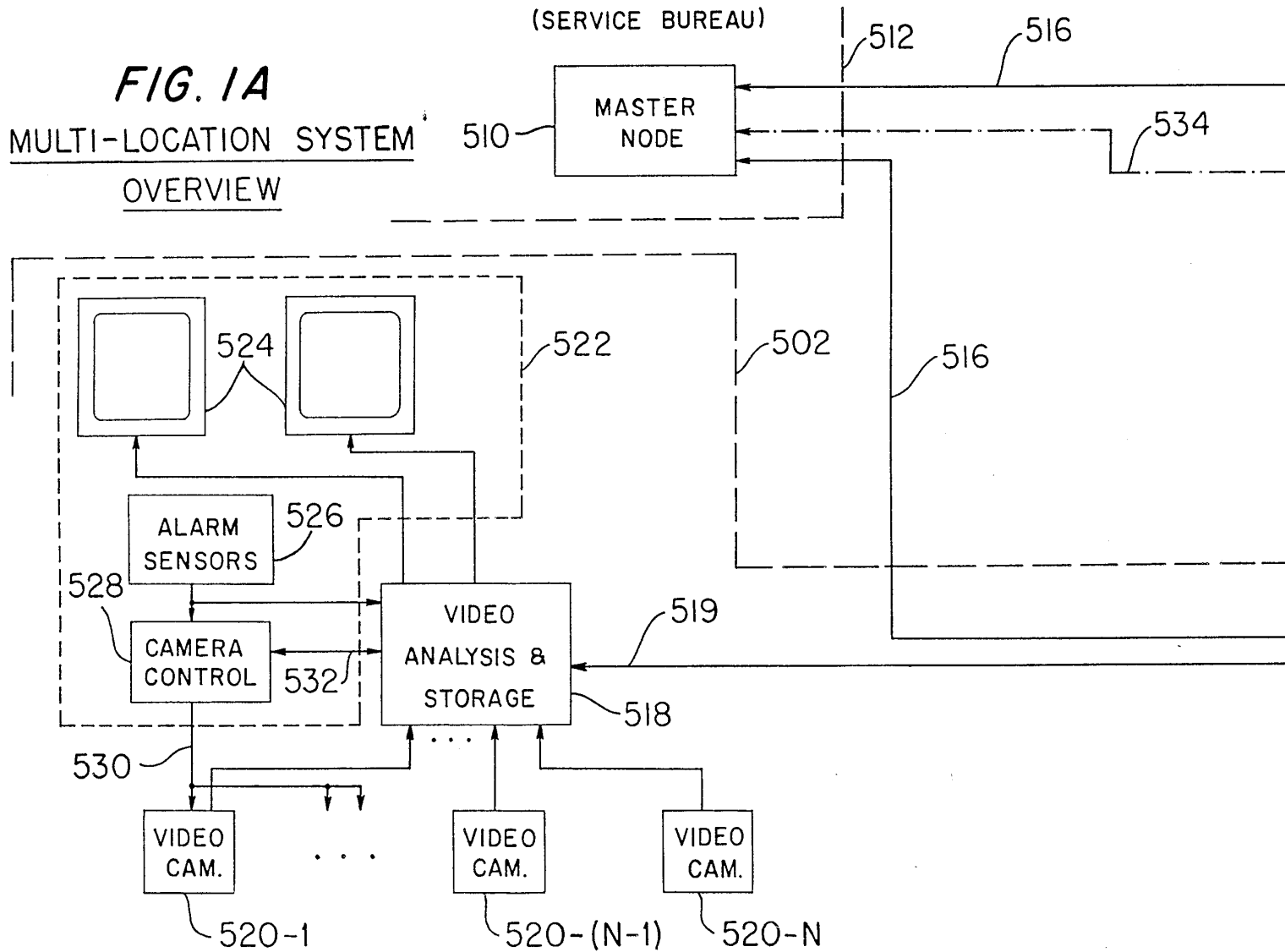
20 590. Apparatus according to claim 56, wherein said moving image content analysis algorithm applied by said analysis means is for detecting moving objects represented by the reproduced fields of video data, and said process result data generated by said processing means is data indicative of detection of a moving object.

25 591. Apparatus according to claim 588, wherein said recording medium is a hard disk.

30 592. Apparatus according to claim 588, wherein said header data includes data for identifying a camera which generated the respective field of video data, and data indicative of a time at which the field of video data was generated.

35

**FIG. 1A**  
**MULTI-LOCATION SYSTEM**  
**OVERVIEW**

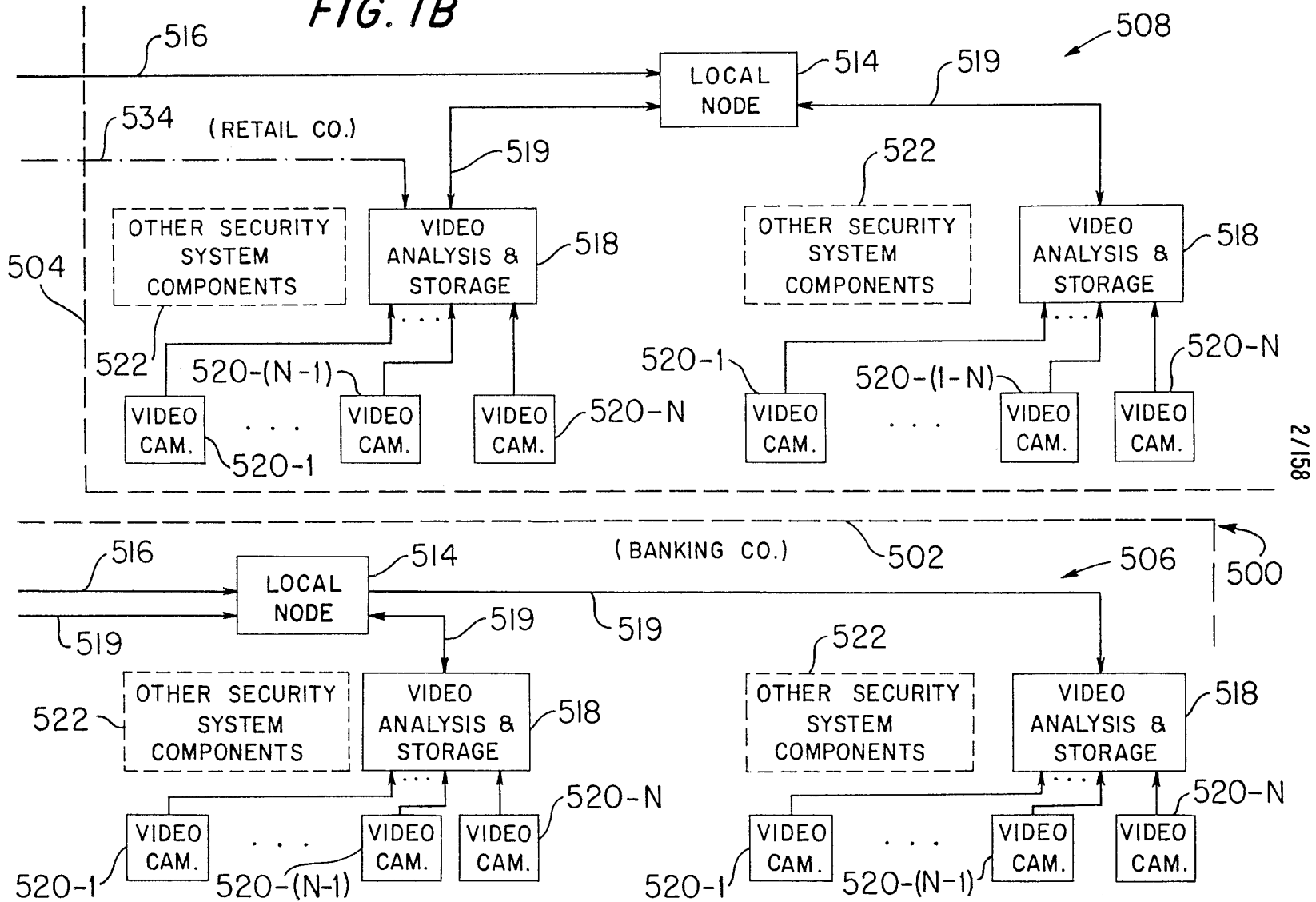


I/158

WO 98/19450

PCT/US97/17886

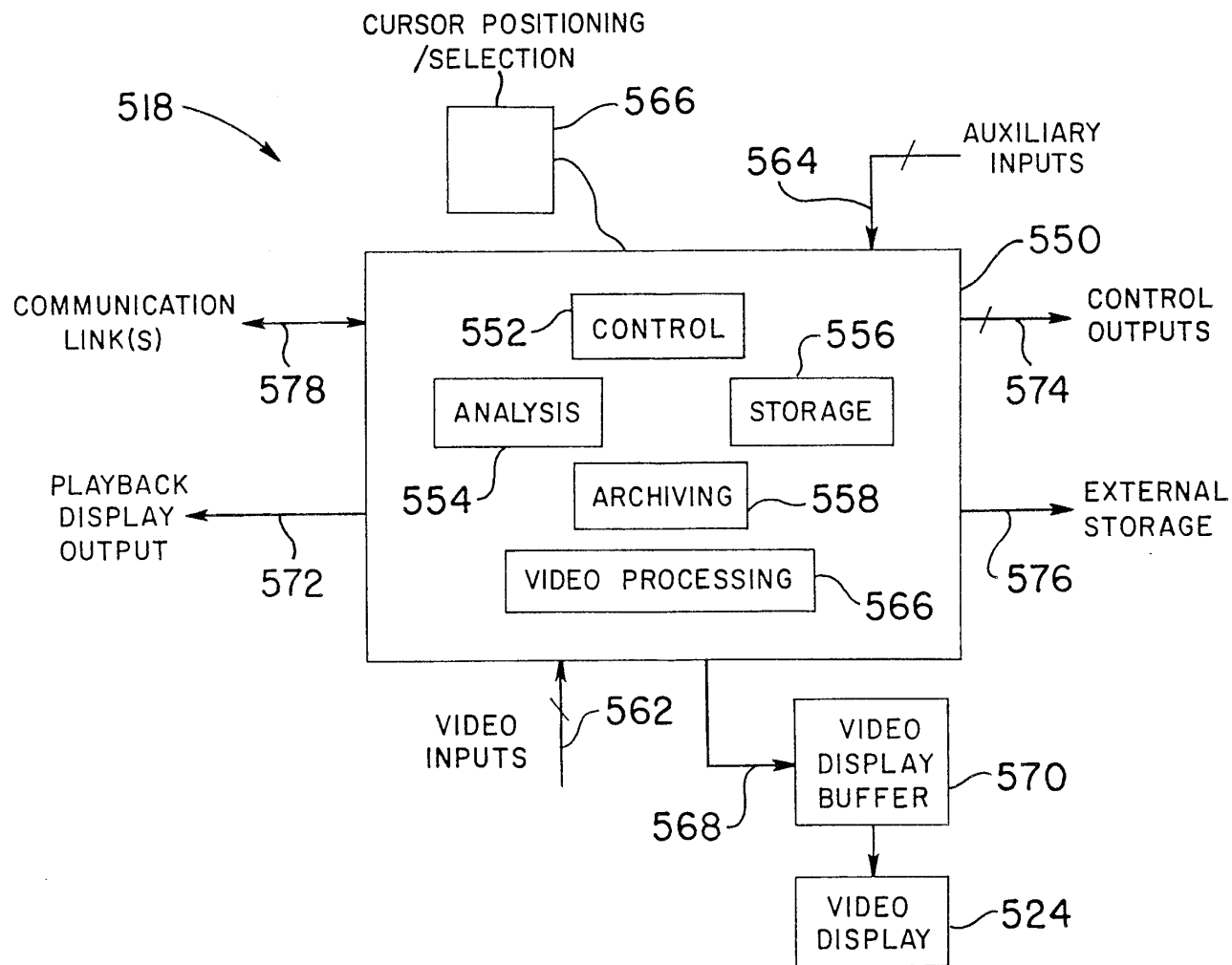
**FIG. 1B**



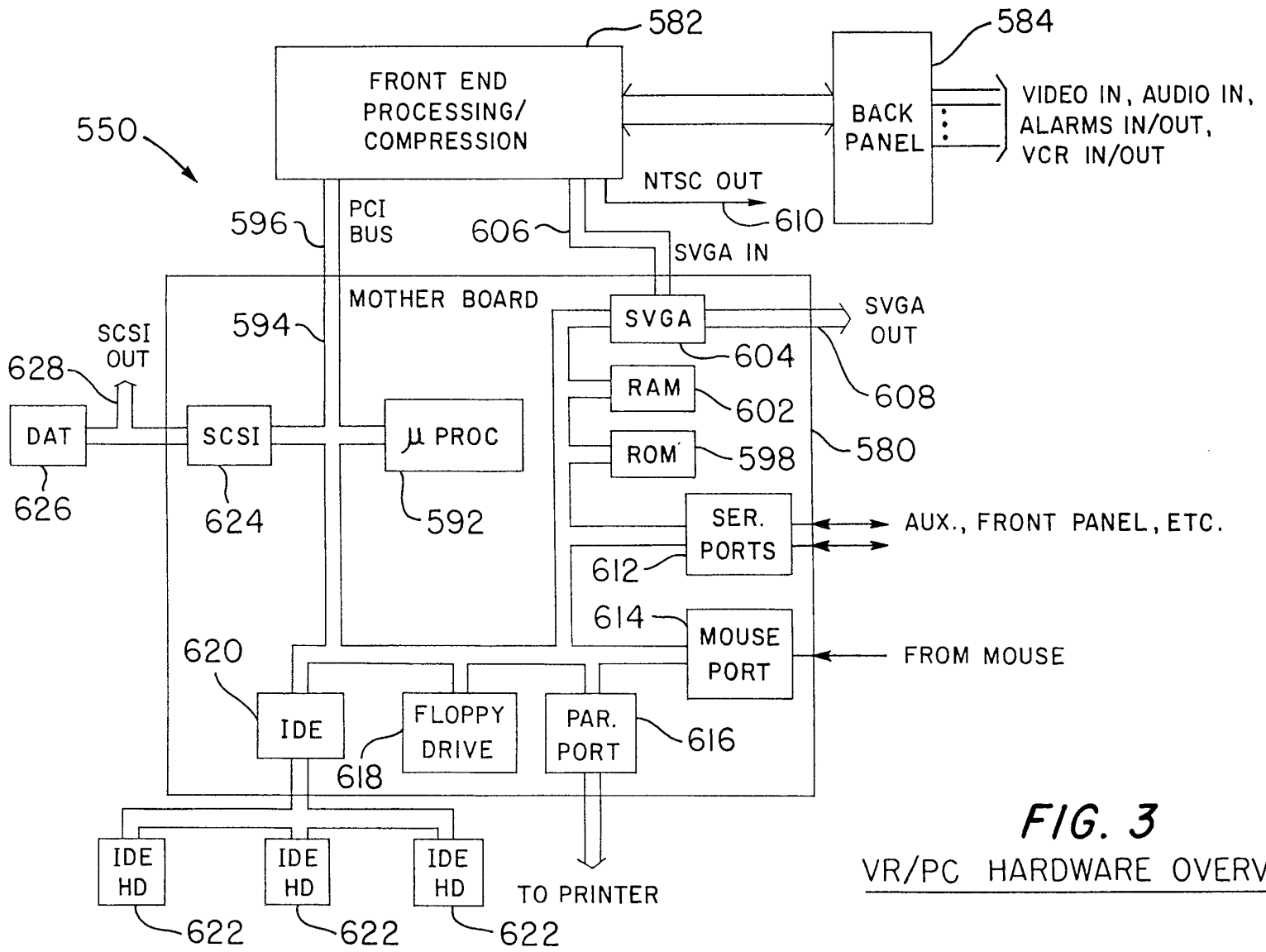
WO 98/19450

2/158

PCT/US97/17886

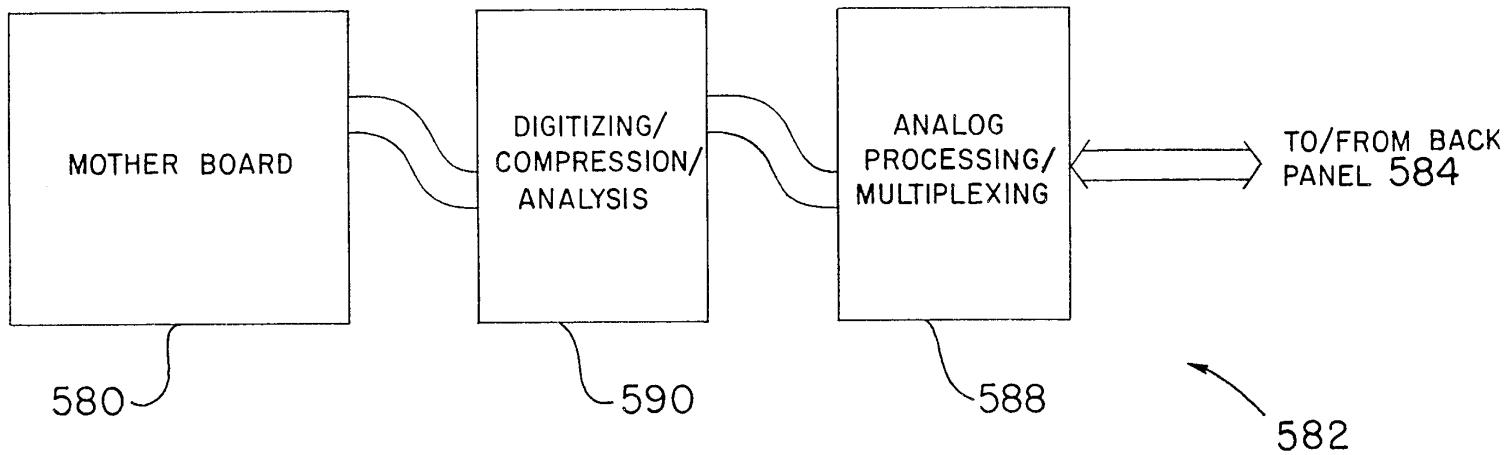


**FIG. 2**  
VIDEO ANALYSIS & STORAGE



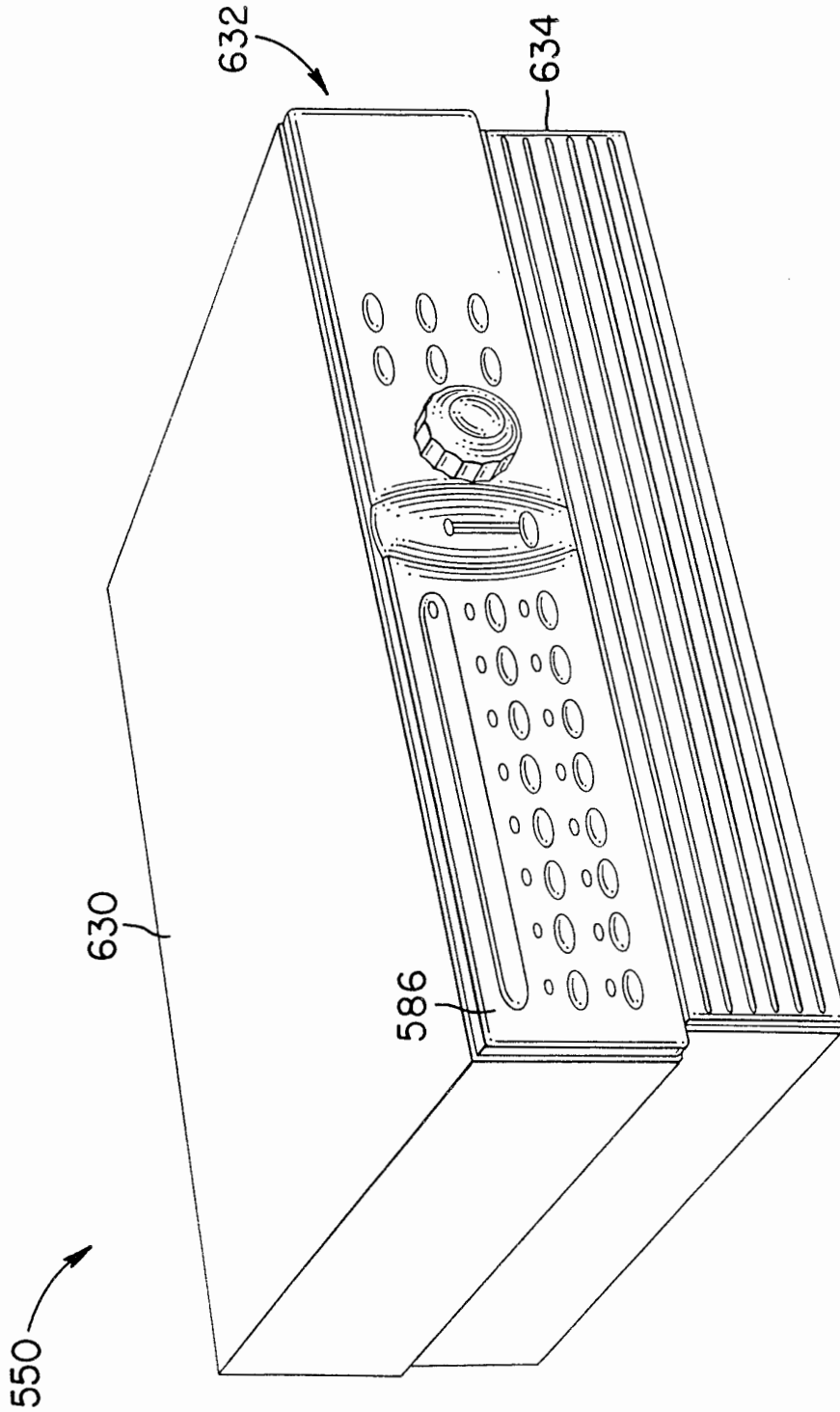
**FIG. 3**  
VR/PC HARDWARE OVERVIEW



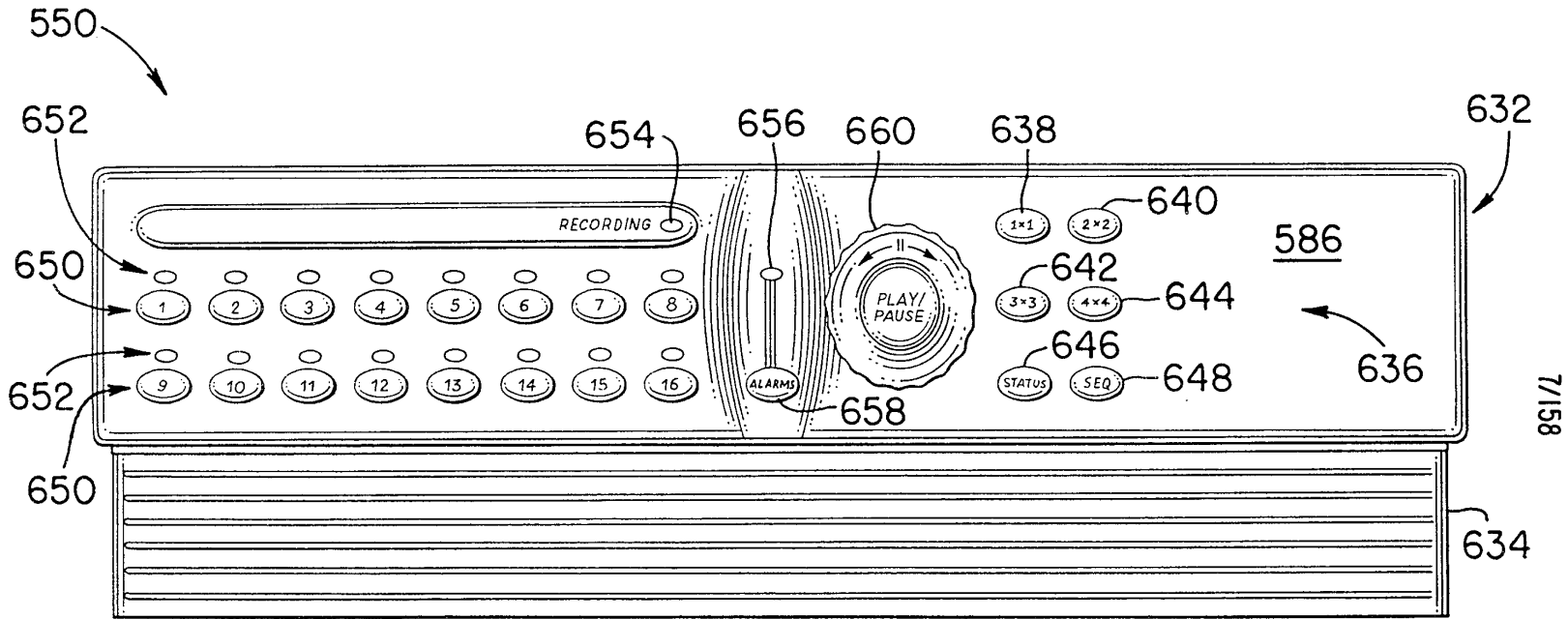


**FIG. 4**  
CIRCUIT BOARD ARCHITECTURE

6/158

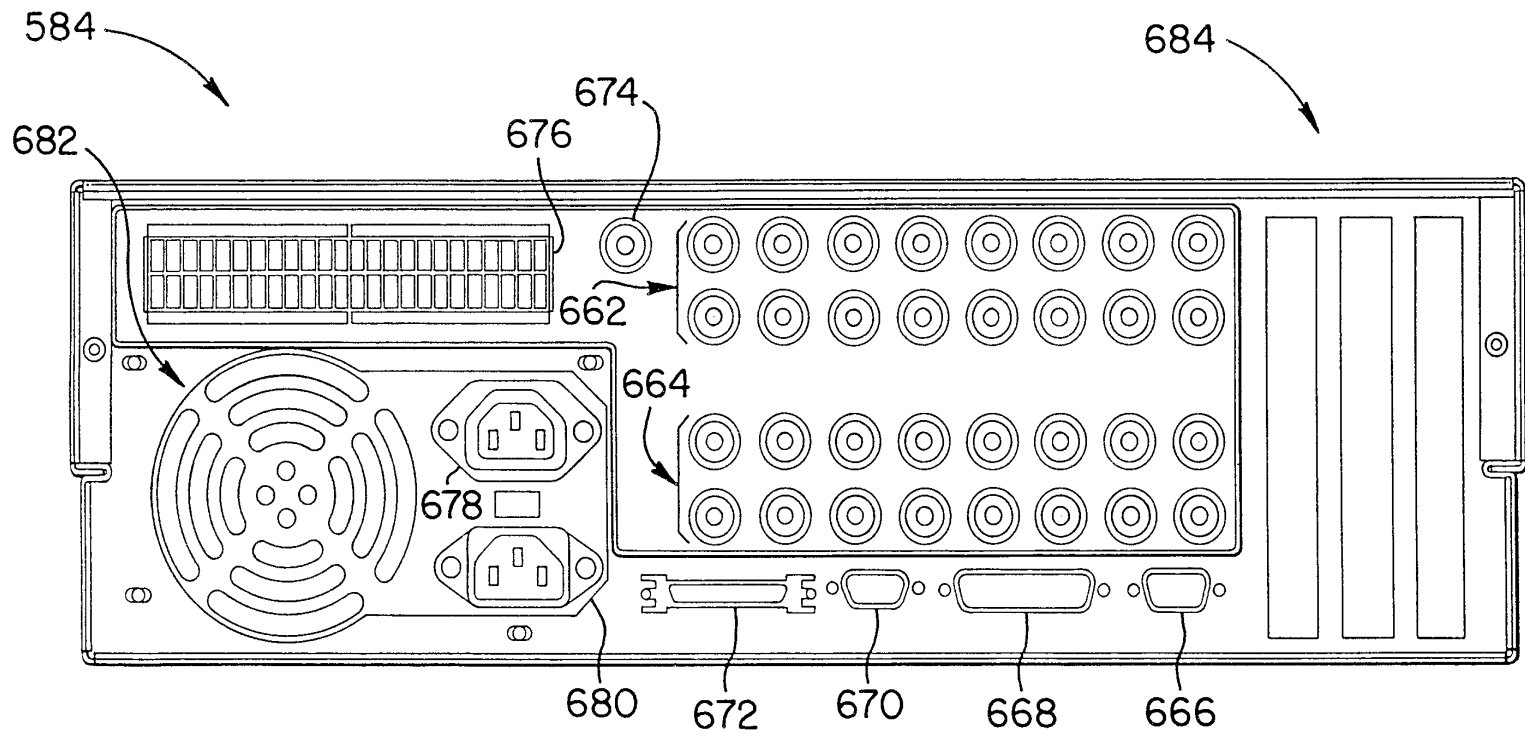


**FIG. 5**  
VR/PC

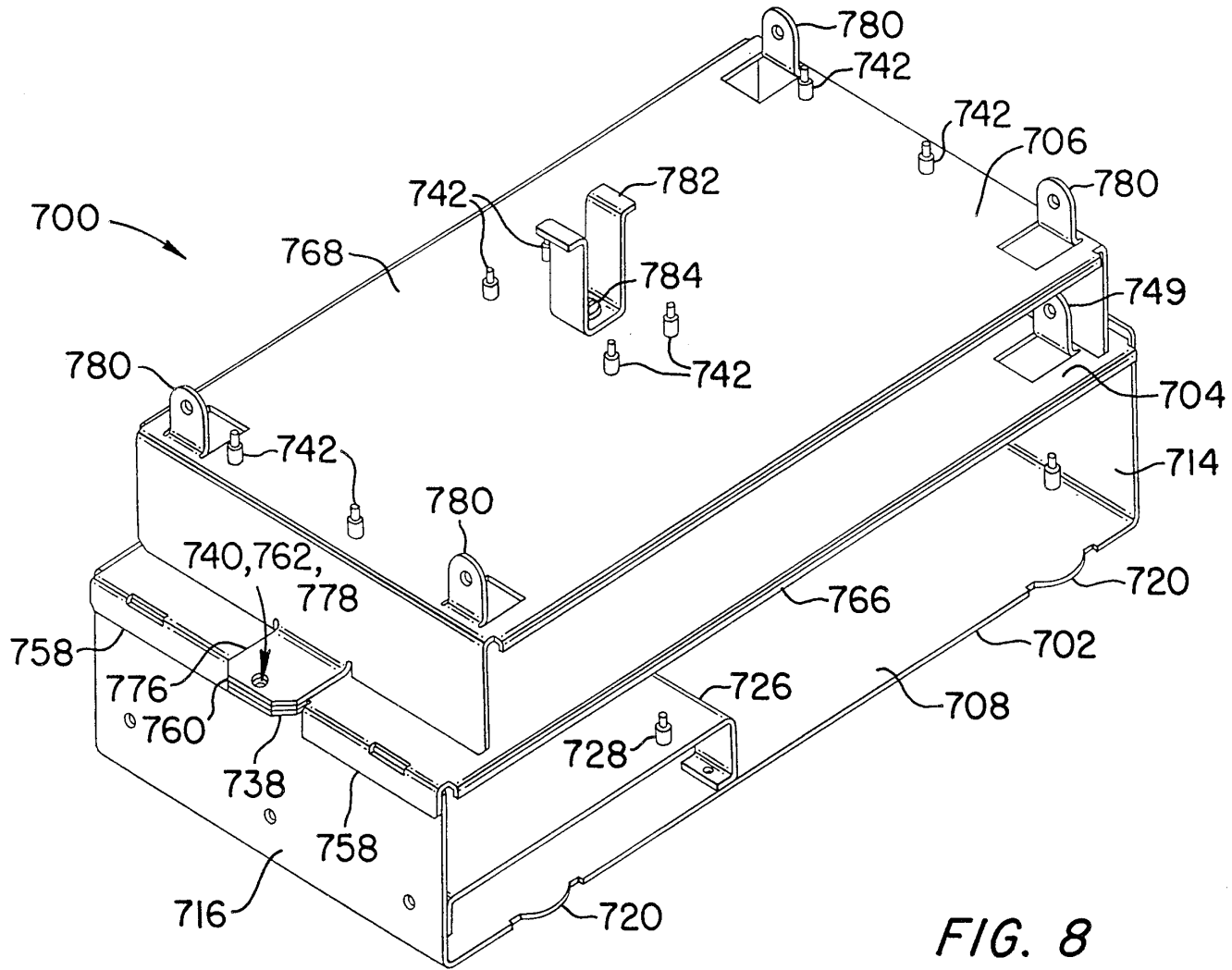


7/158

**FIG. 6**  
FRONT PANEL



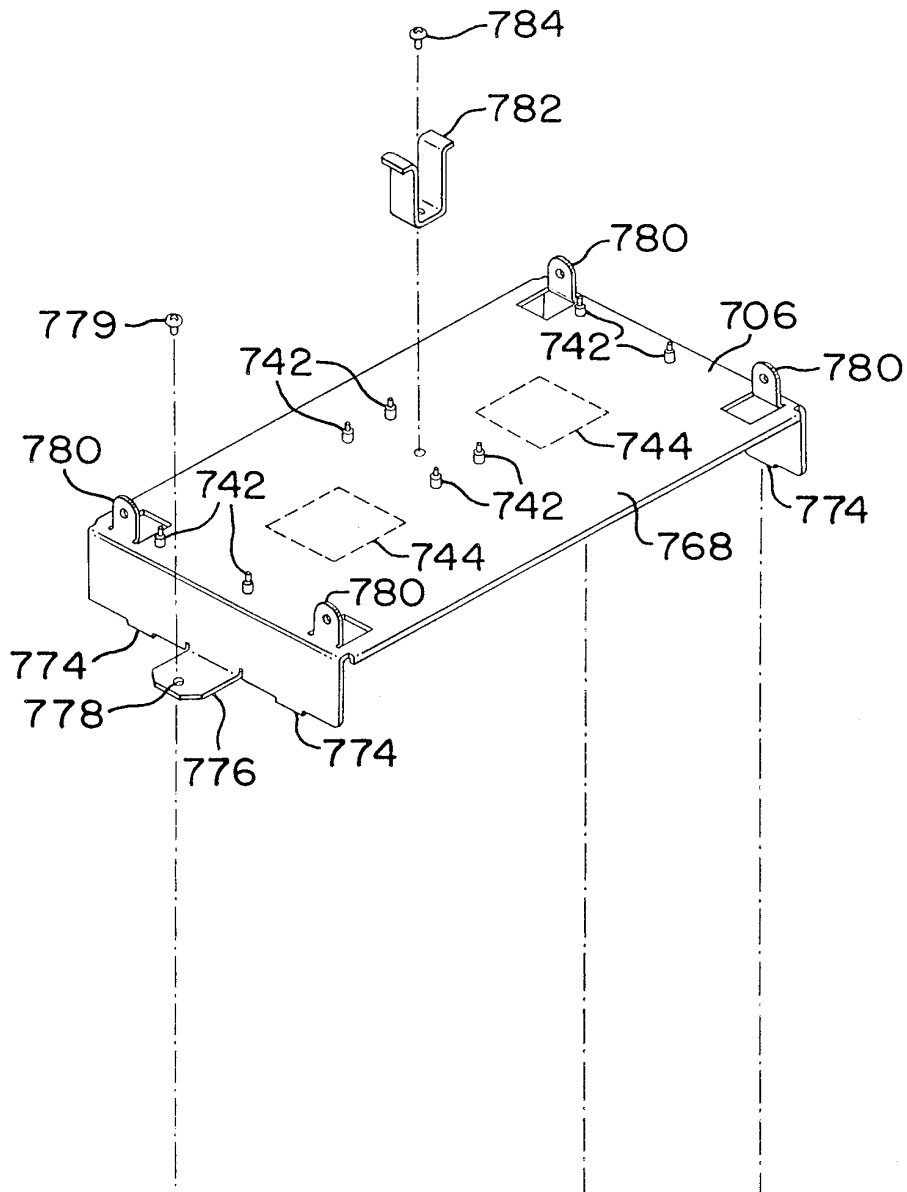
**FIG. 7**  
REAR ELEVATION



**FIG. 8**  
MEDIA DRIVE SUPPORT ASSEMBLY

10/158

**FIG. 9A**  
**MEDIA DRIVE**  
**SUPPORT ASSEMBLY**



11/158

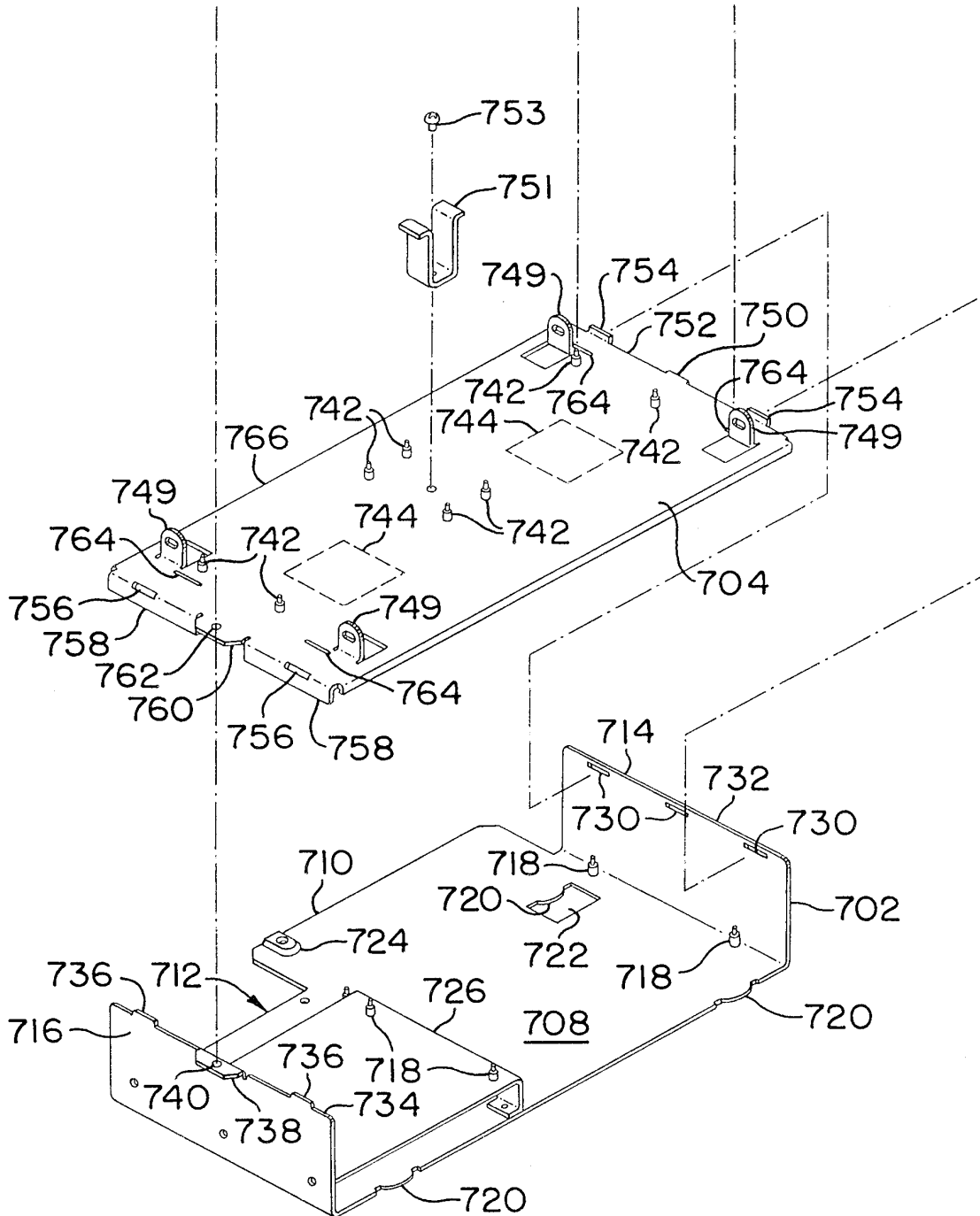
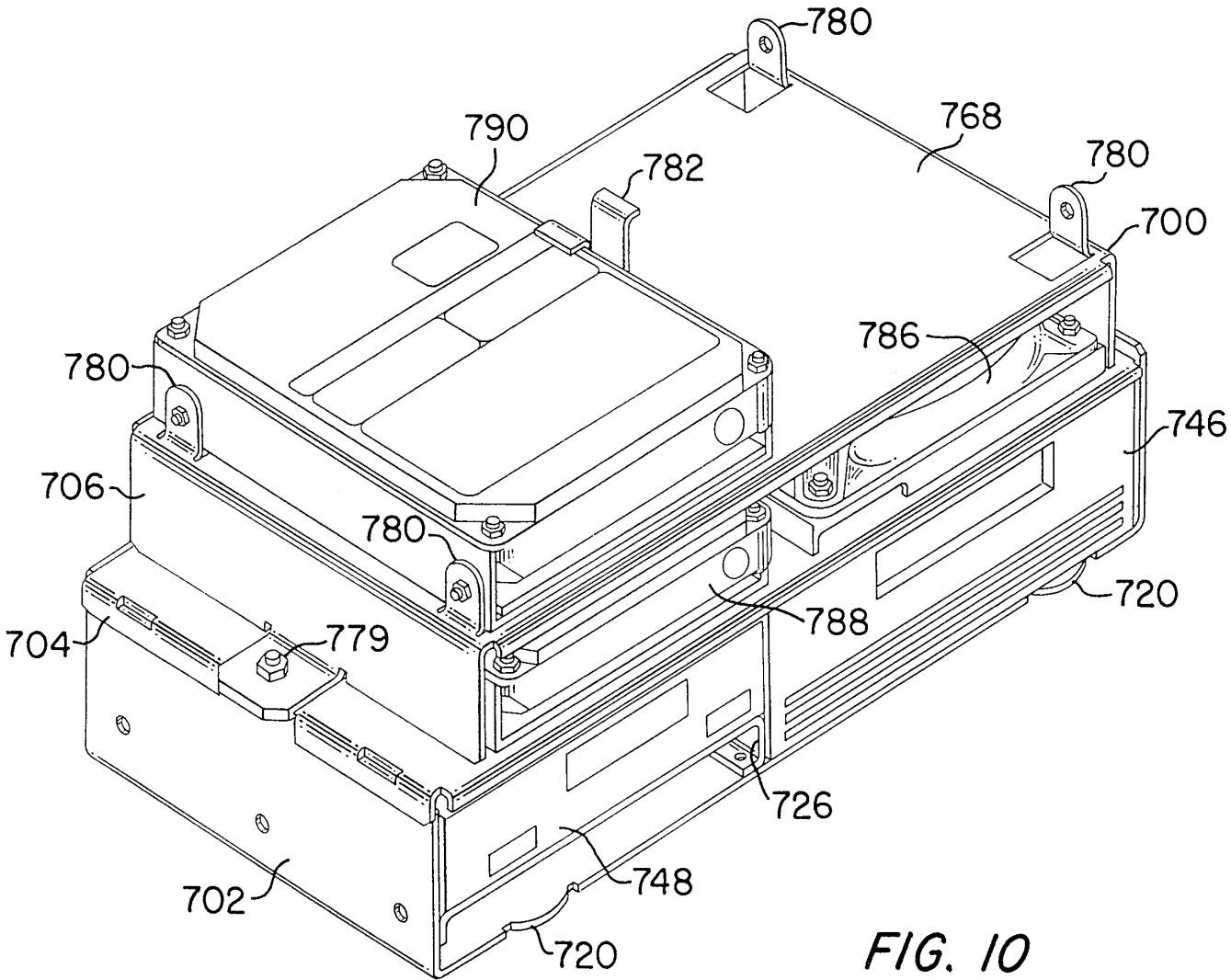
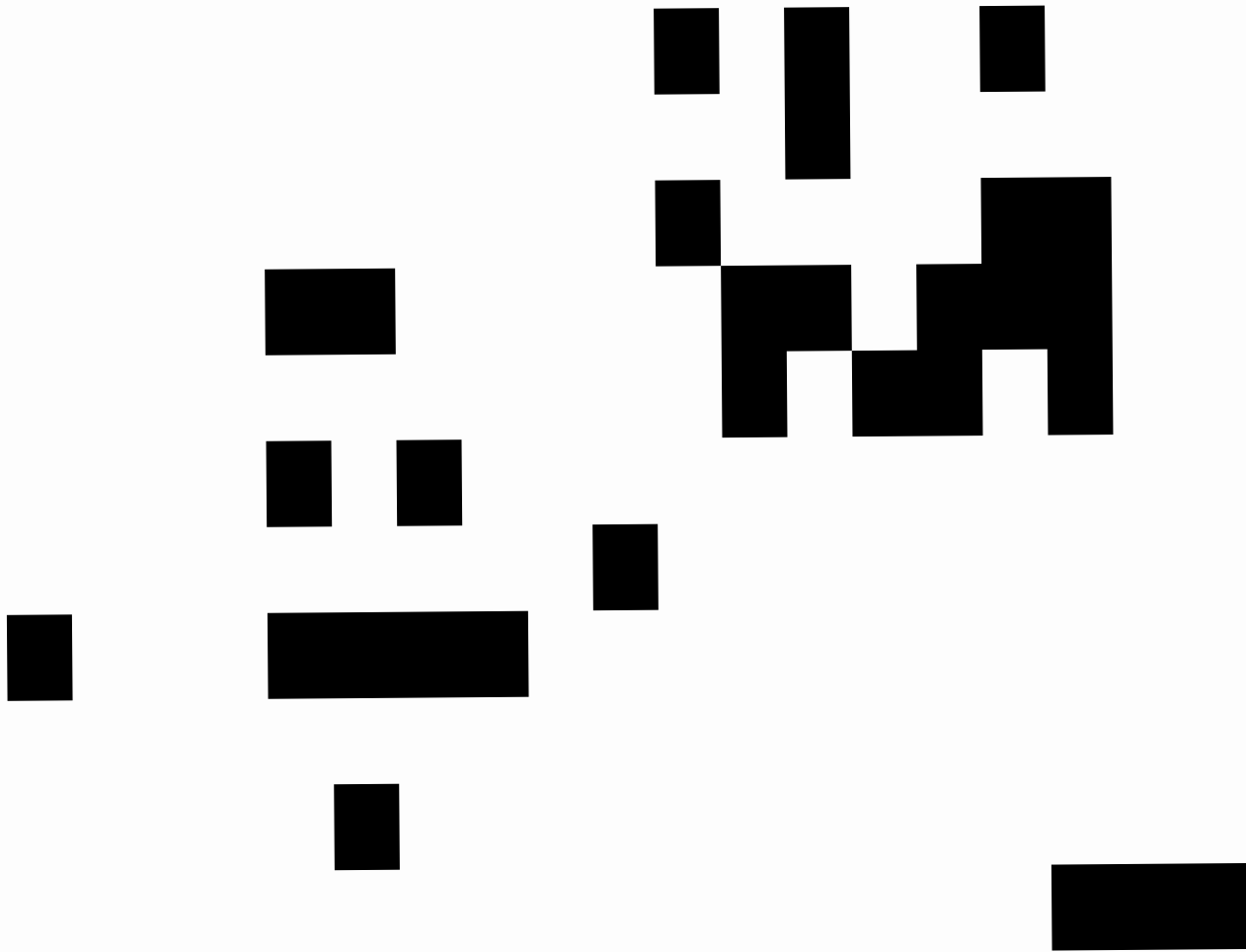


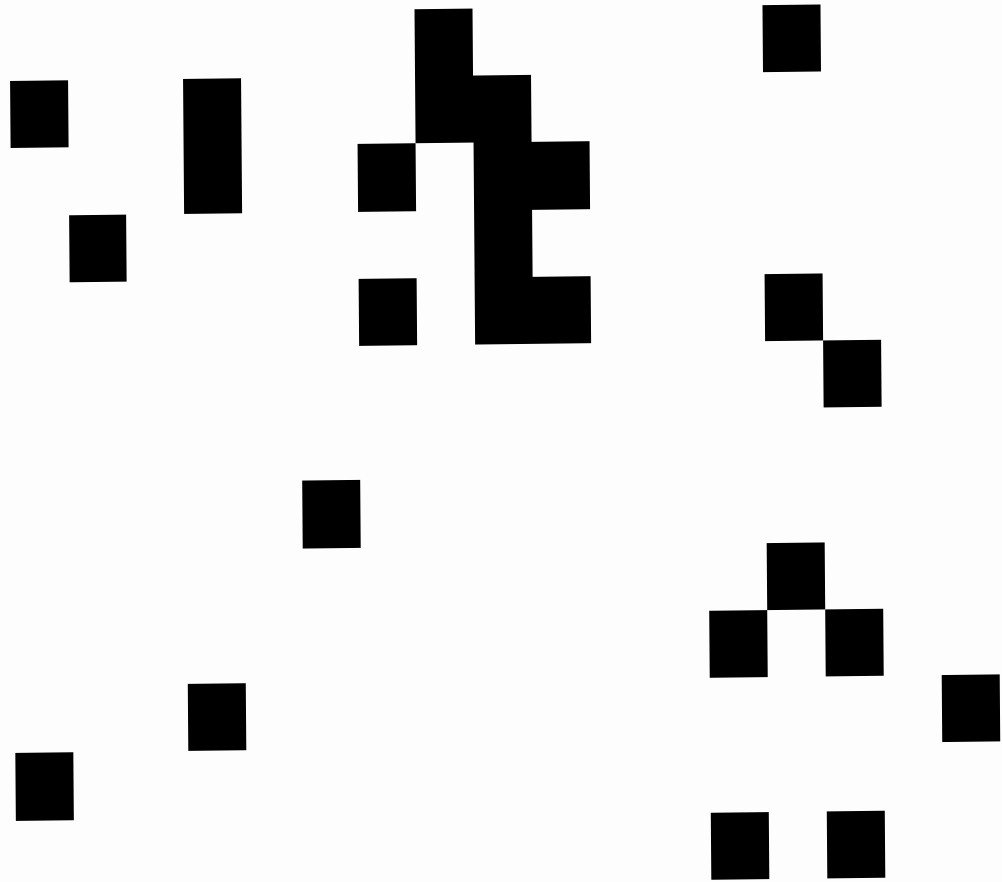
FIG. 9B

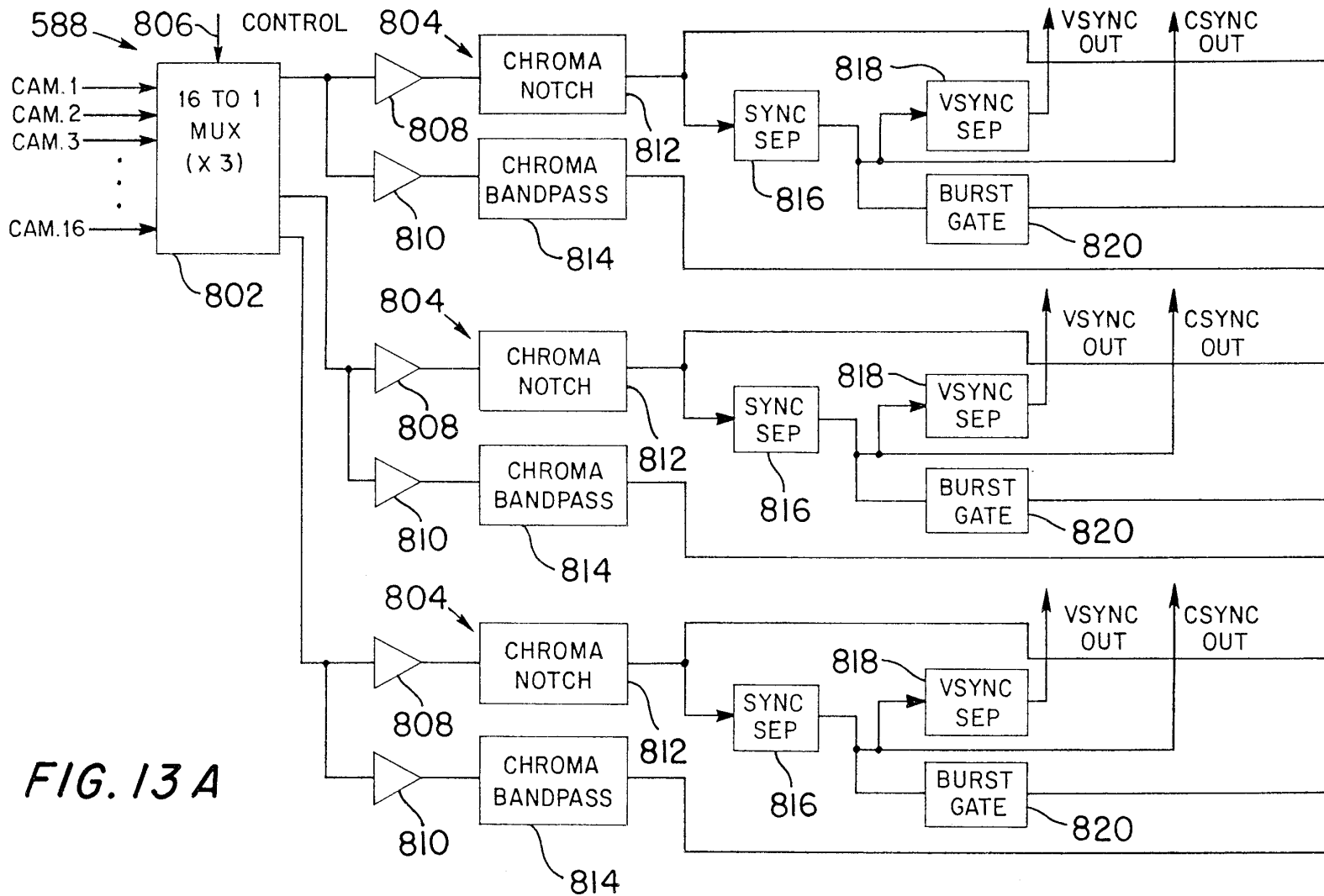


**FIG. 10**  
**MEDIA DRIVE ASSEMBLY**





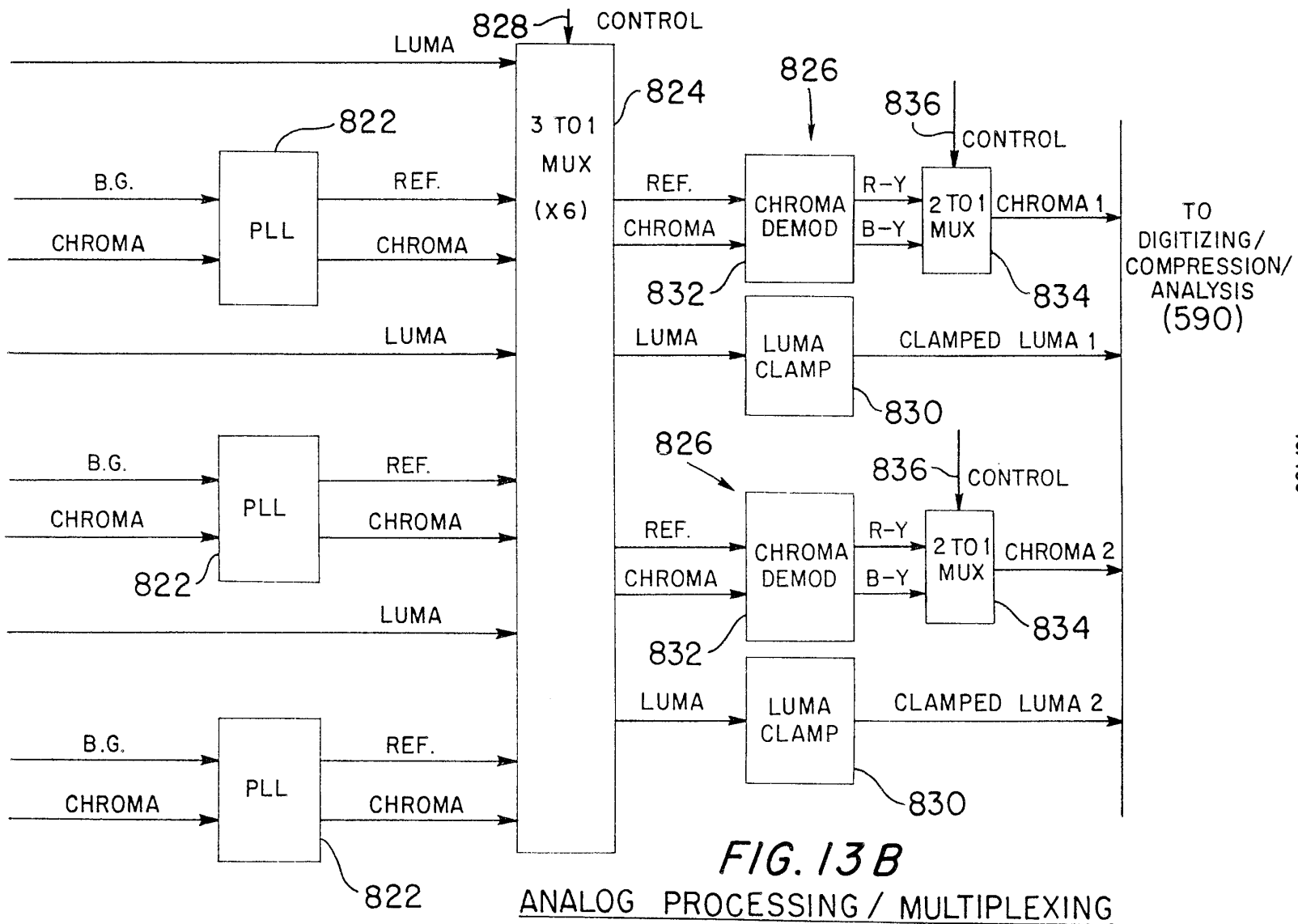


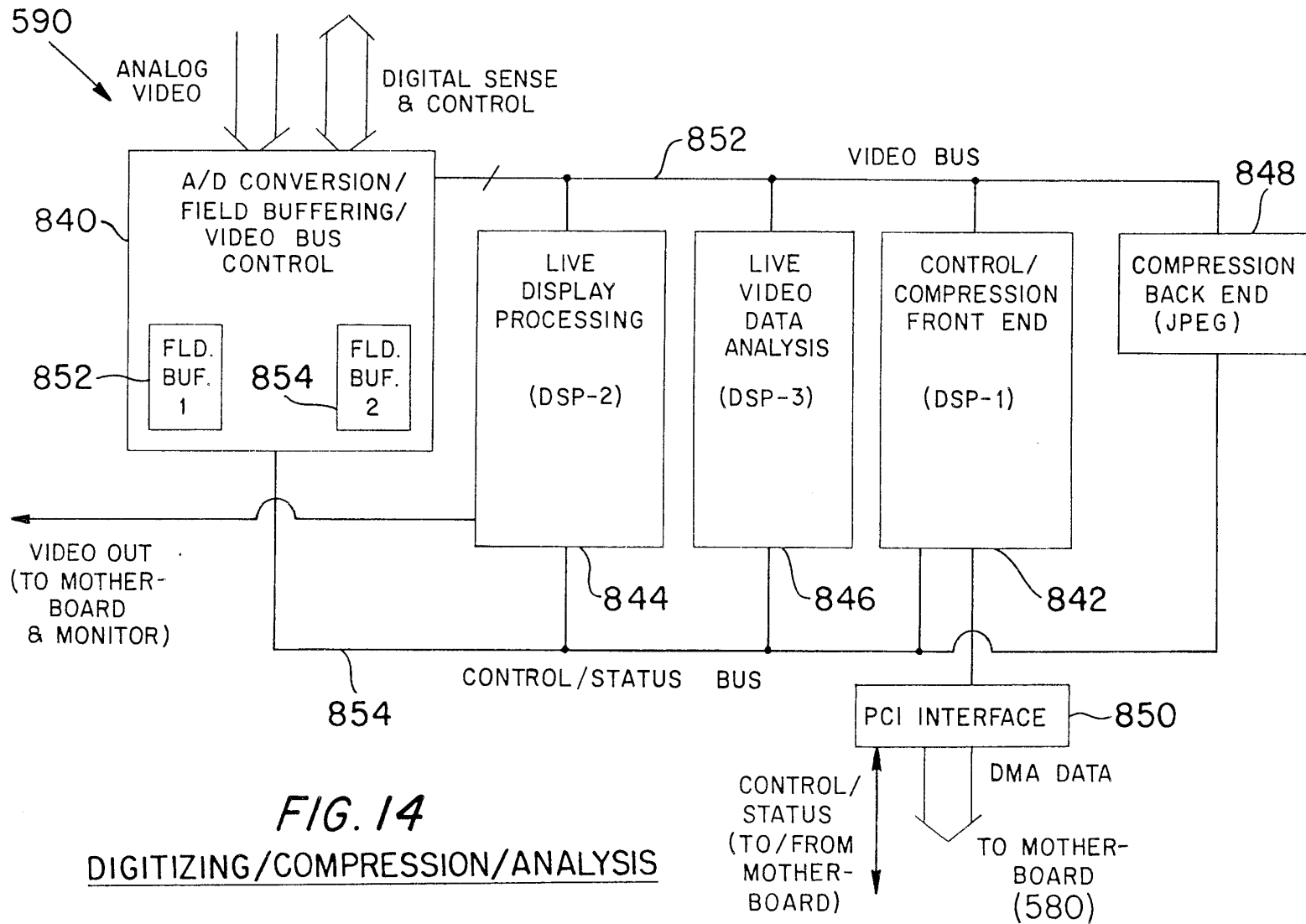


WO 98/19450

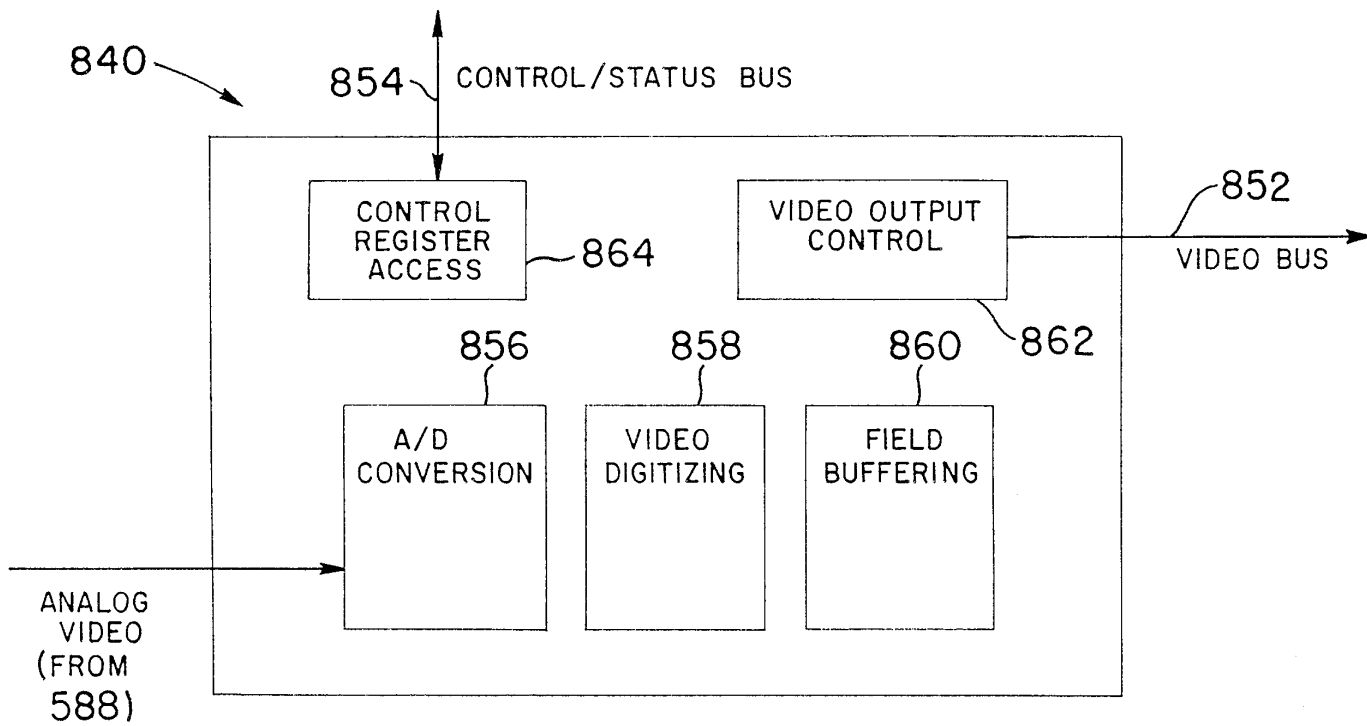
15/158

PCT/US97/17886

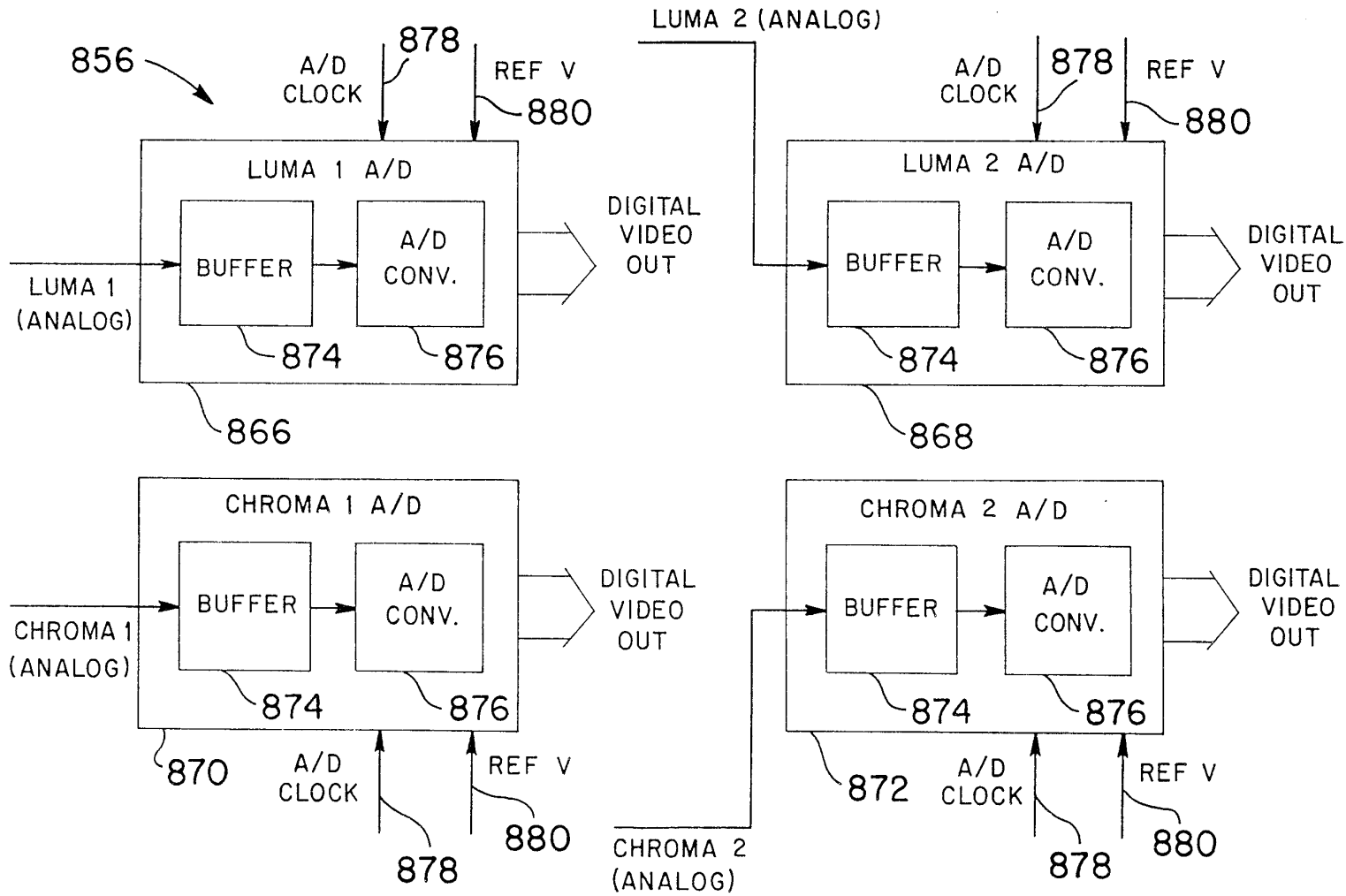




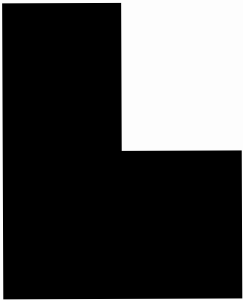
**FIG. 14**  
DIGITIZING/COMPRESSION/ANALYSIS



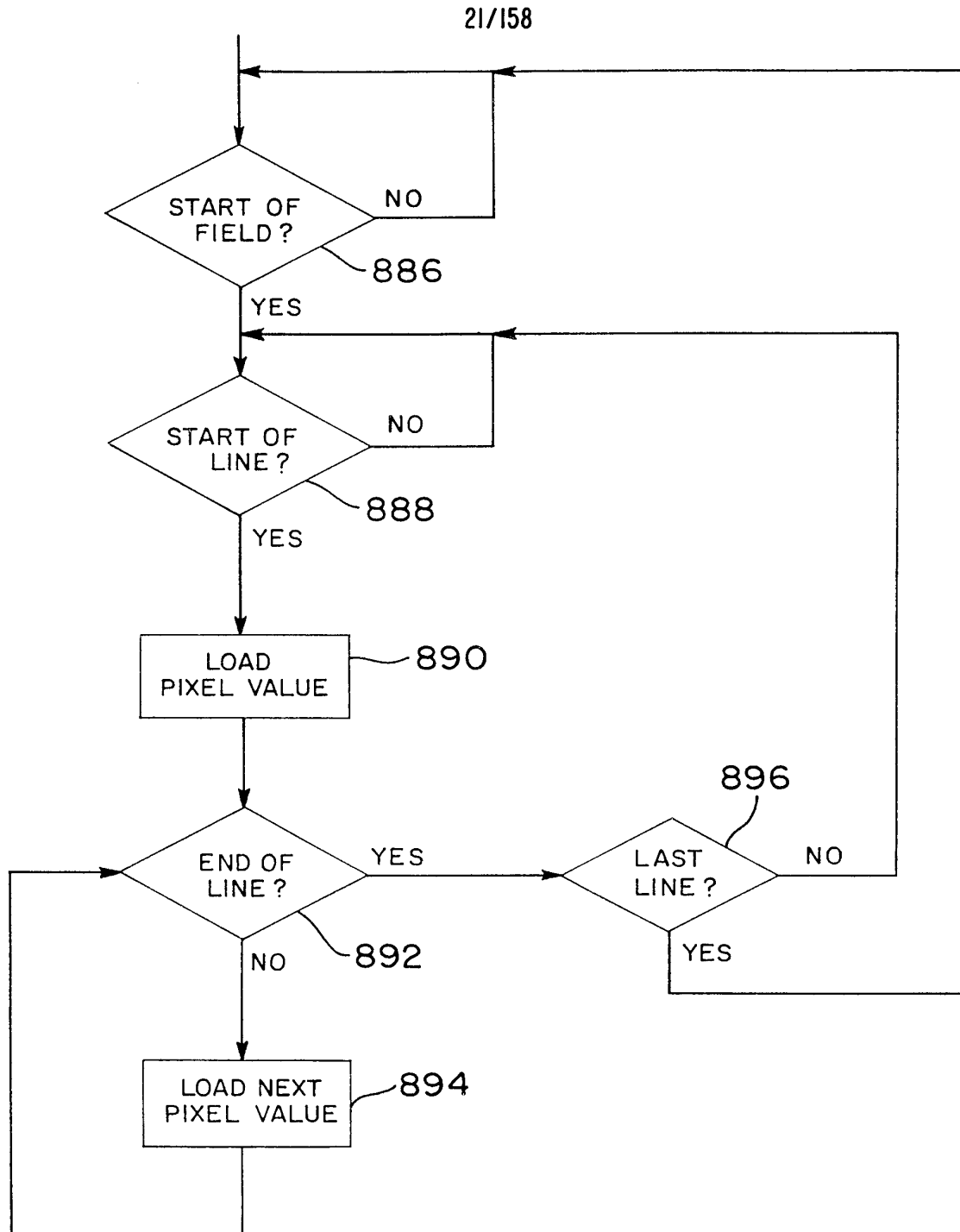
**FIG. 15**  
A/D CONVERSION/FIELD BUFFERING/VIDEO BUS CONTROL



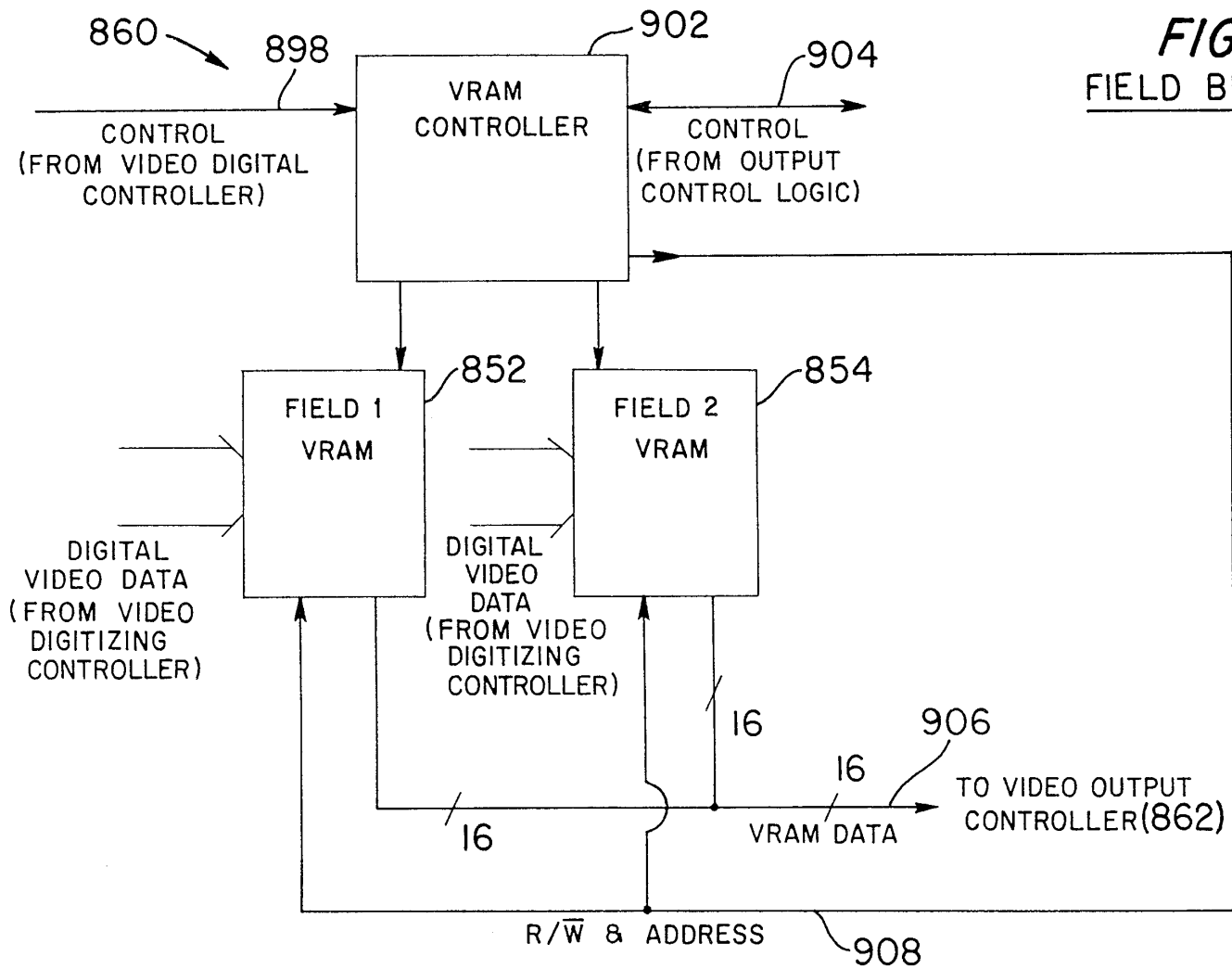
**FIG. 16**  
**A/D CONVERSION**



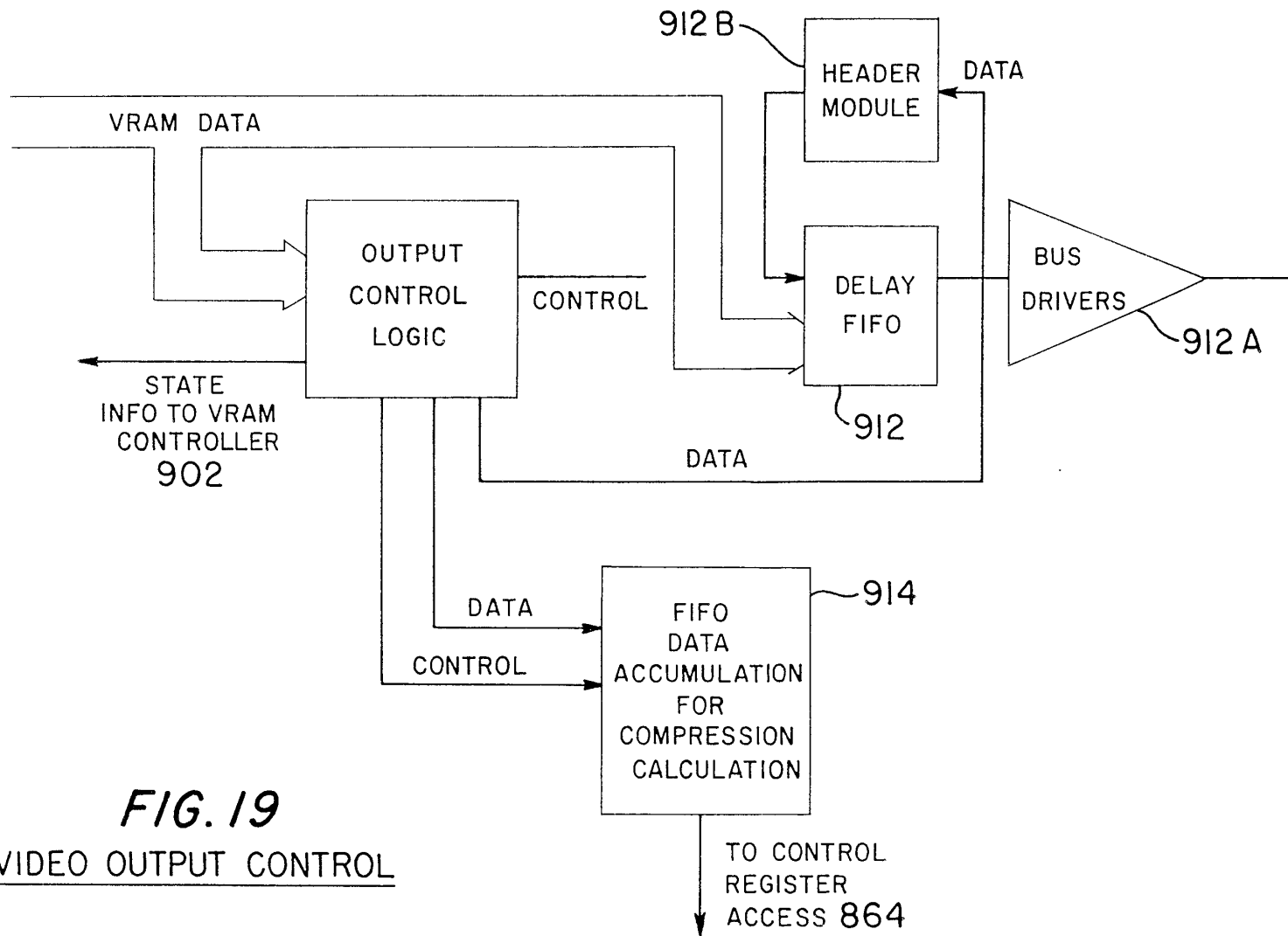




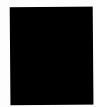
**FIG. 17 A**  
CONTROLLER LOGIC  
(VIDEO DIGITIZING CONTROLLER)



**FIG. 18**  
**FIELD BUFFERING**



**FIG. 19**  
VIDEO OUTPUT CONTROL





[REDACTED]

[REDACTED]

[REDACTED]

[REDACTED]

[REDACTED]

[REDACTED]

[REDACTED]

[REDACTED]

[REDACTED]

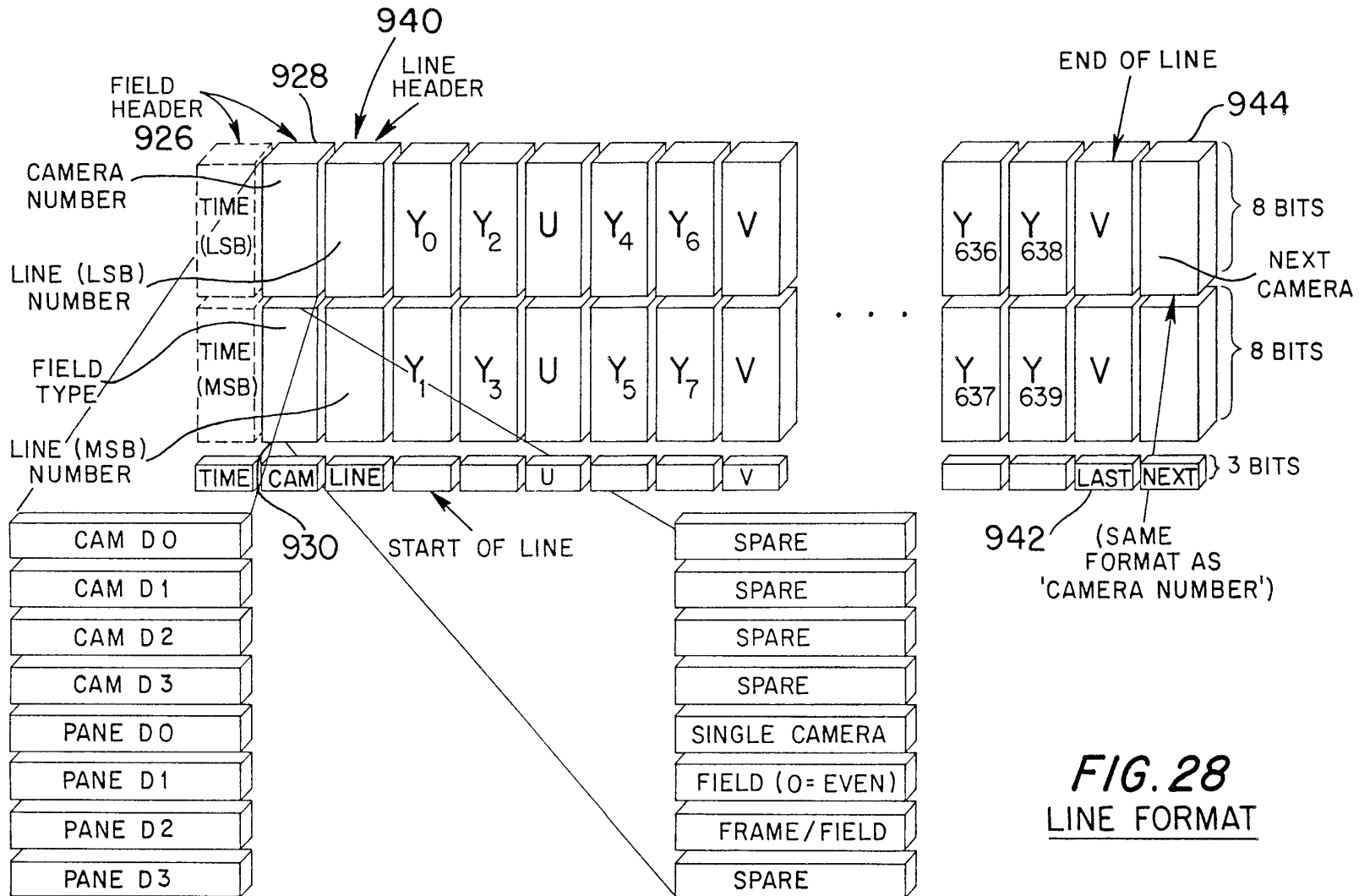
[REDACTED]

[REDACTED]

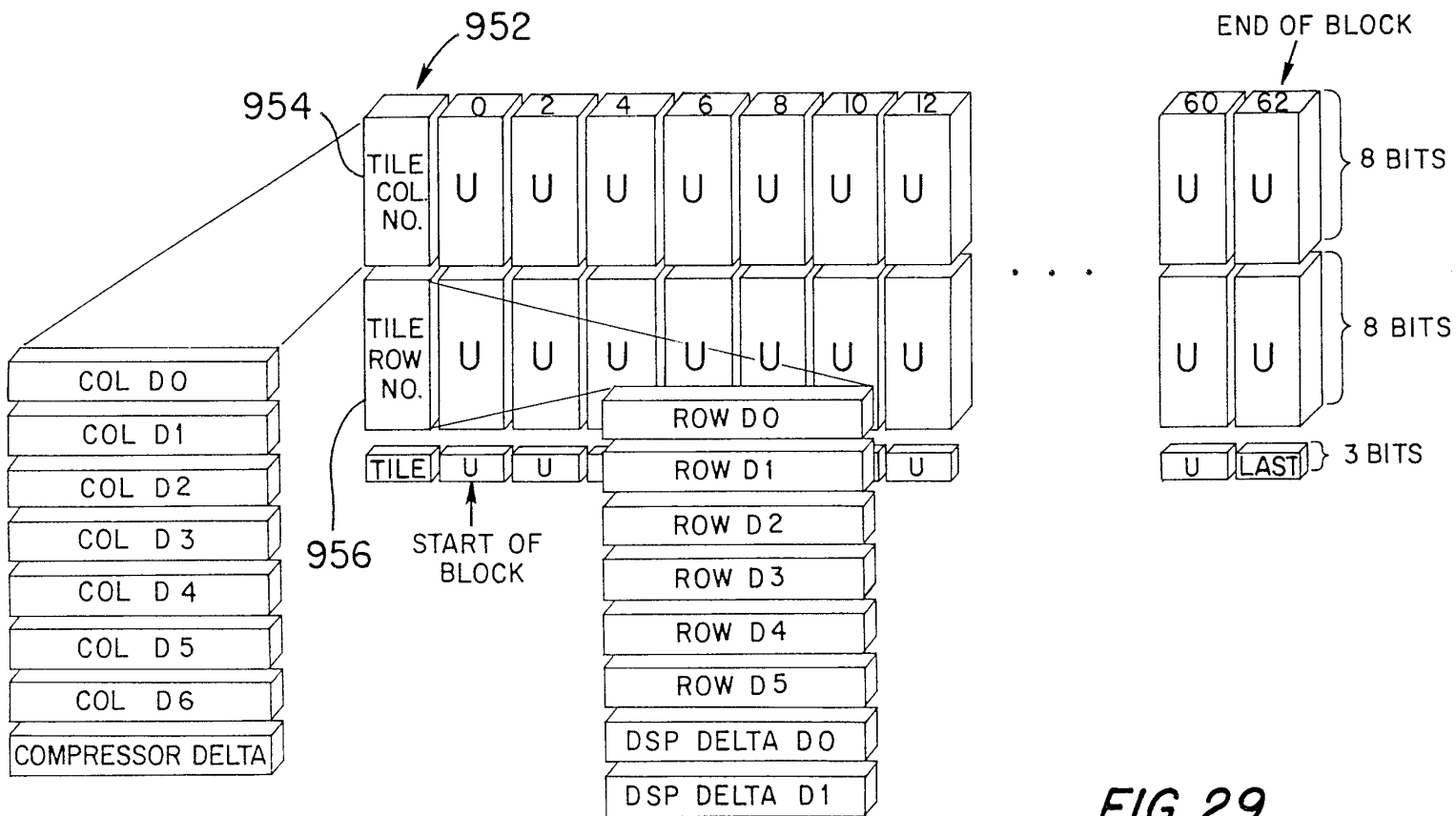
[REDACTED]

[REDACTED]

[REDACTED]

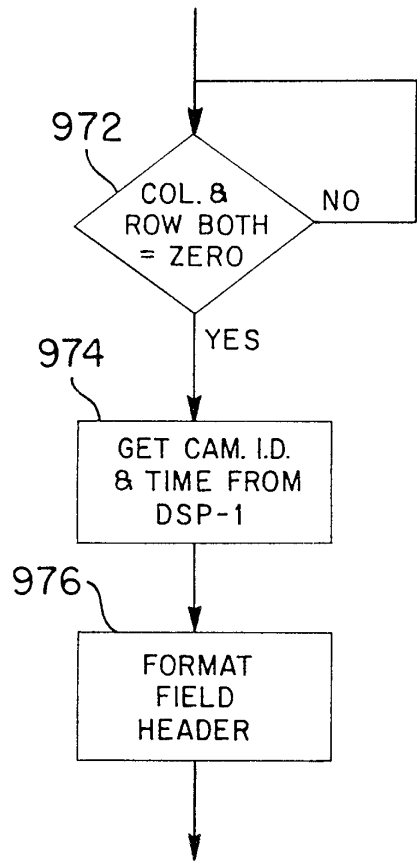


**FIG. 28**  
**LINE FORMAT**

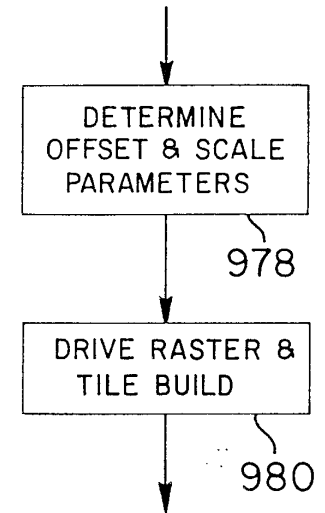


**FIG. 29**  
**TILE FORMAT**

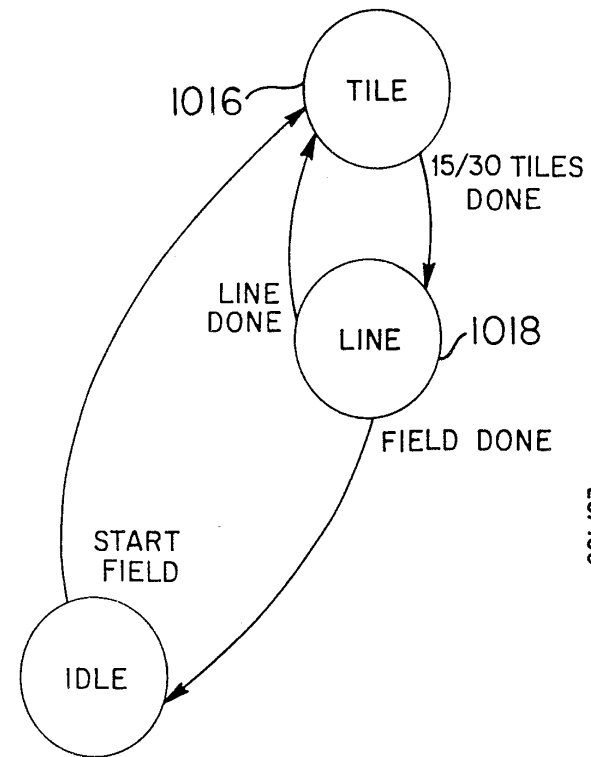




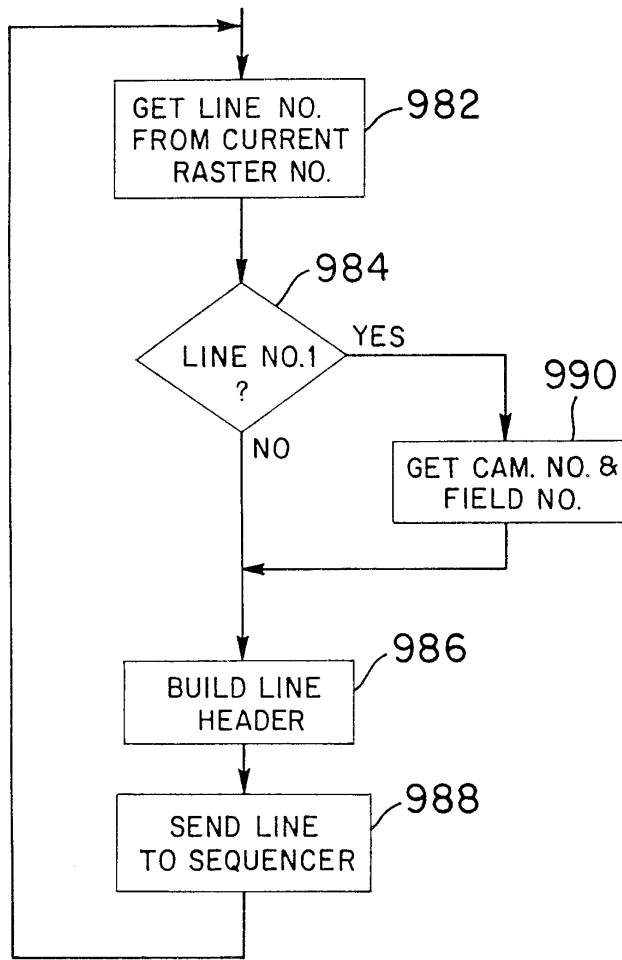
**FIG. 31A**  
BUILD FIELD HEADER



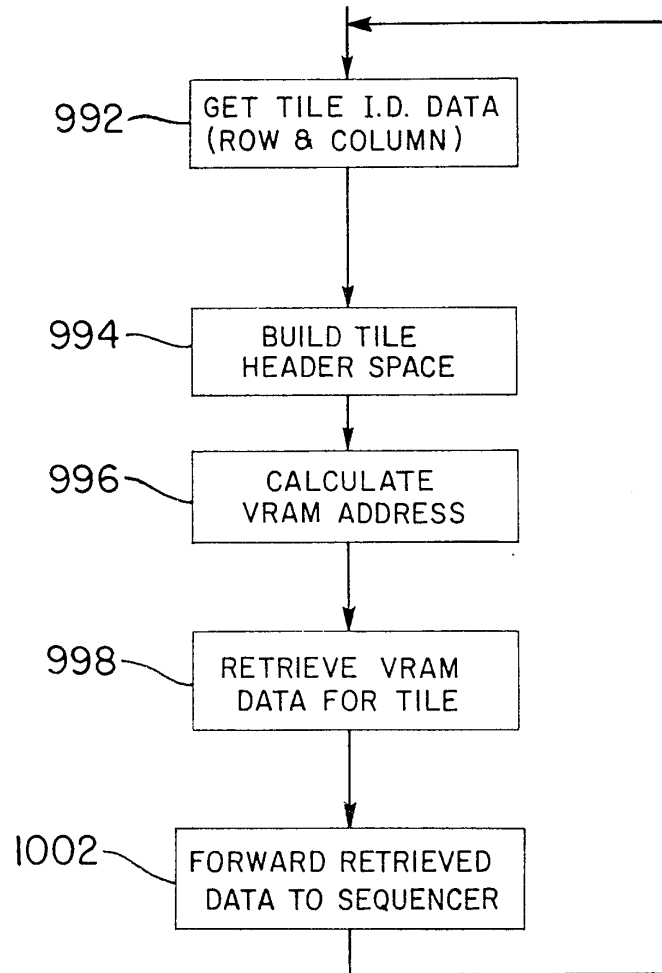
**FIG. 31B**  
HEADER TRANS-LATE LOGIC



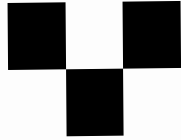
**FIG. 35**  
CONTROLLING STATE MACHINE  
(VIDEO BUS CONTROL)

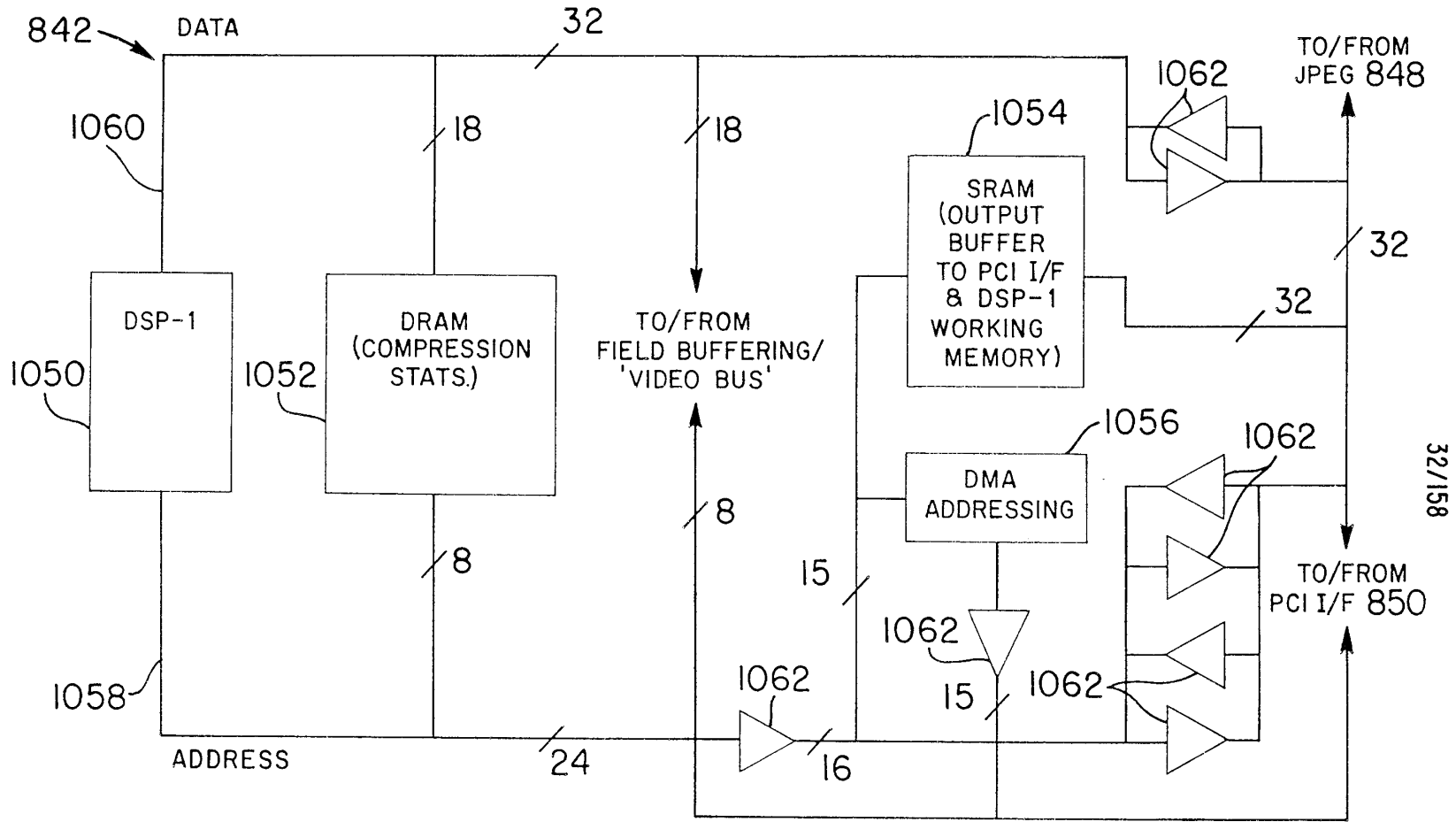


**FIG. 32**  
RASTER BUILD LOGIC

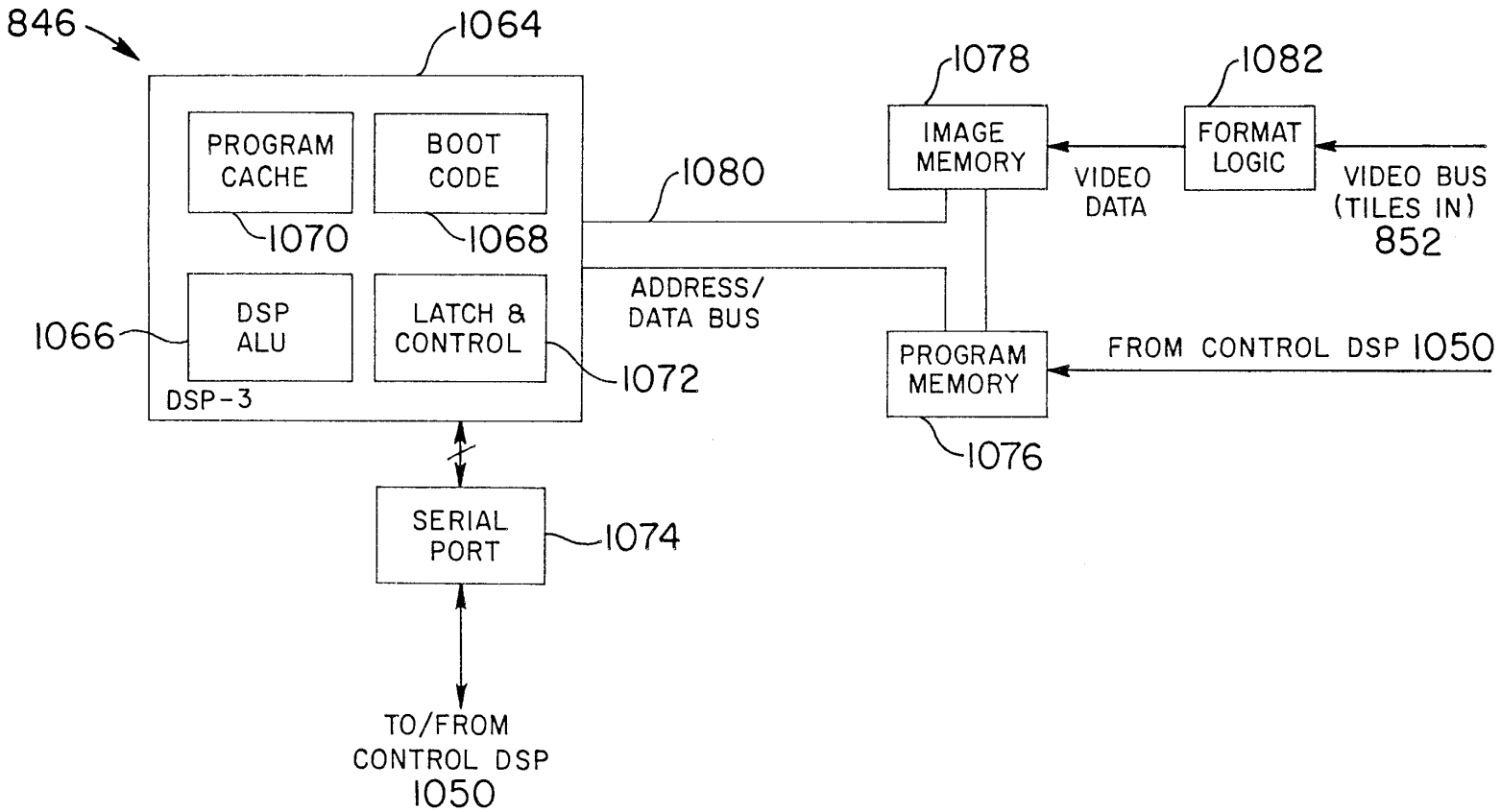


**FIG. 33**  
TILE BUILD LOGIC



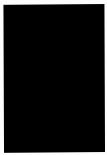


**FIG. 36**  
CONTROL/COMPRESSION FRONT END

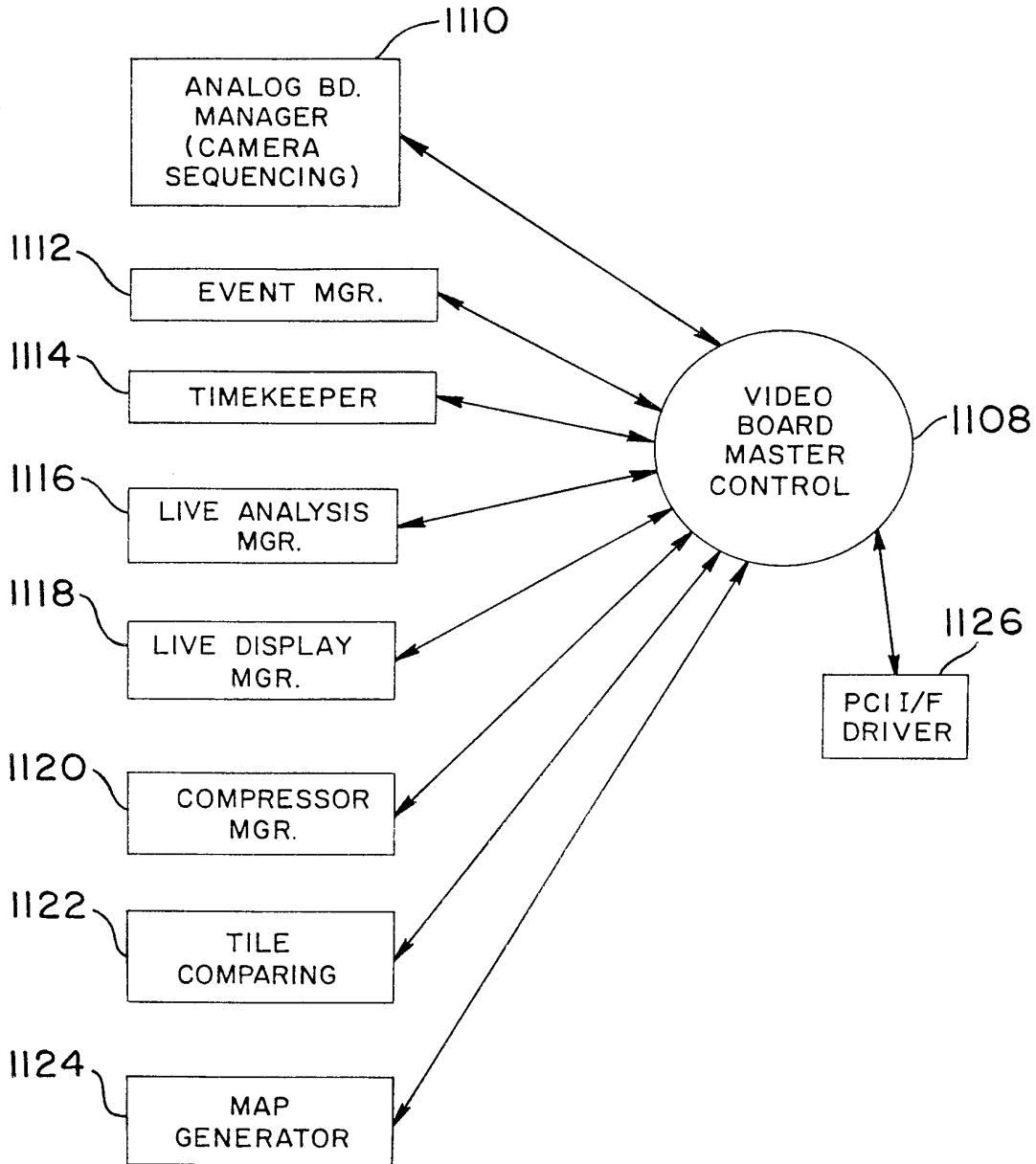


33/158

**FIG. 37**  
LIVE VIDEO DATA ANALYSIS

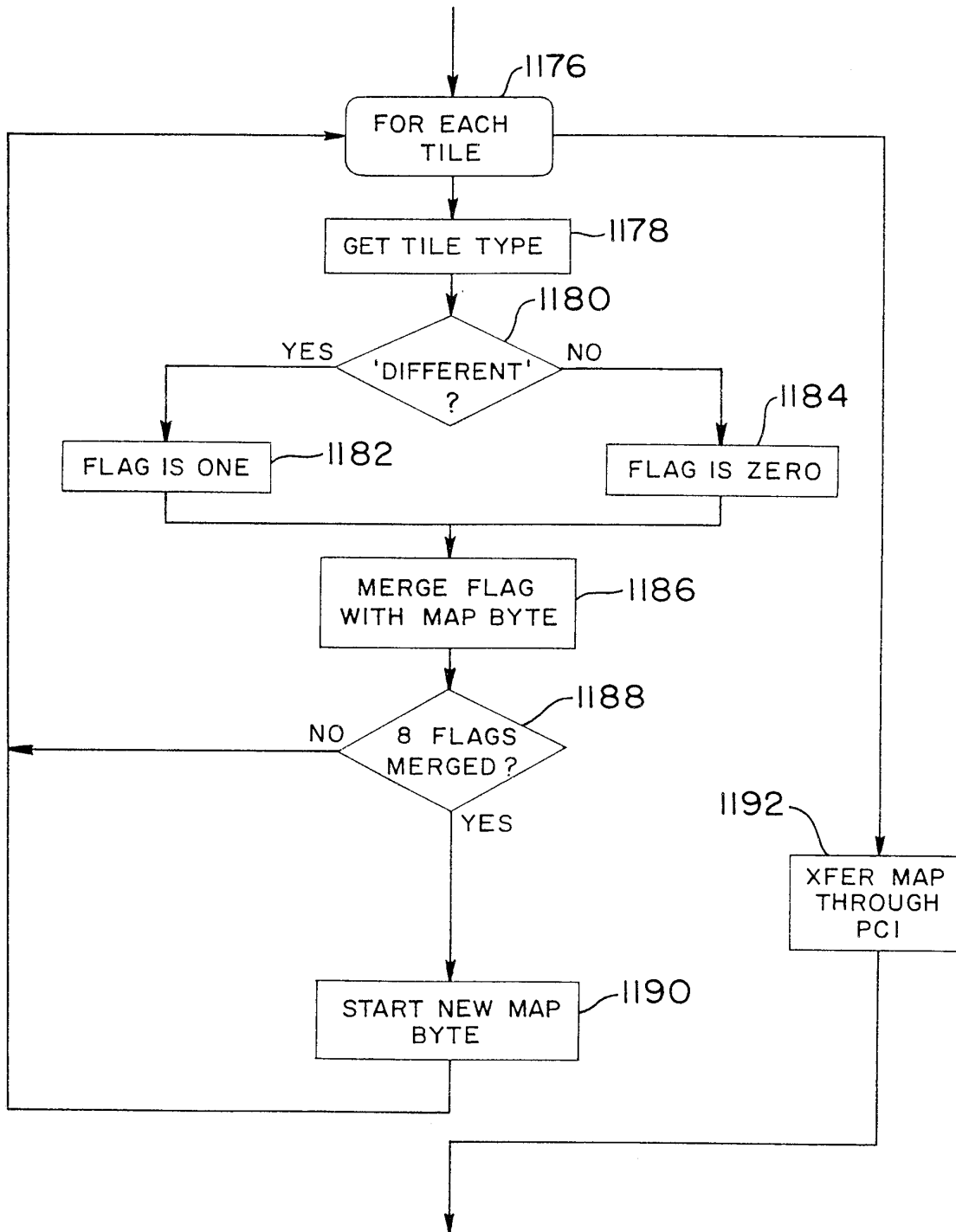


35/158



**FIG. 39**  
DSP-1 (VIDEO BOARD CONTROLLER)  
SOFTWARE OVERVIEW

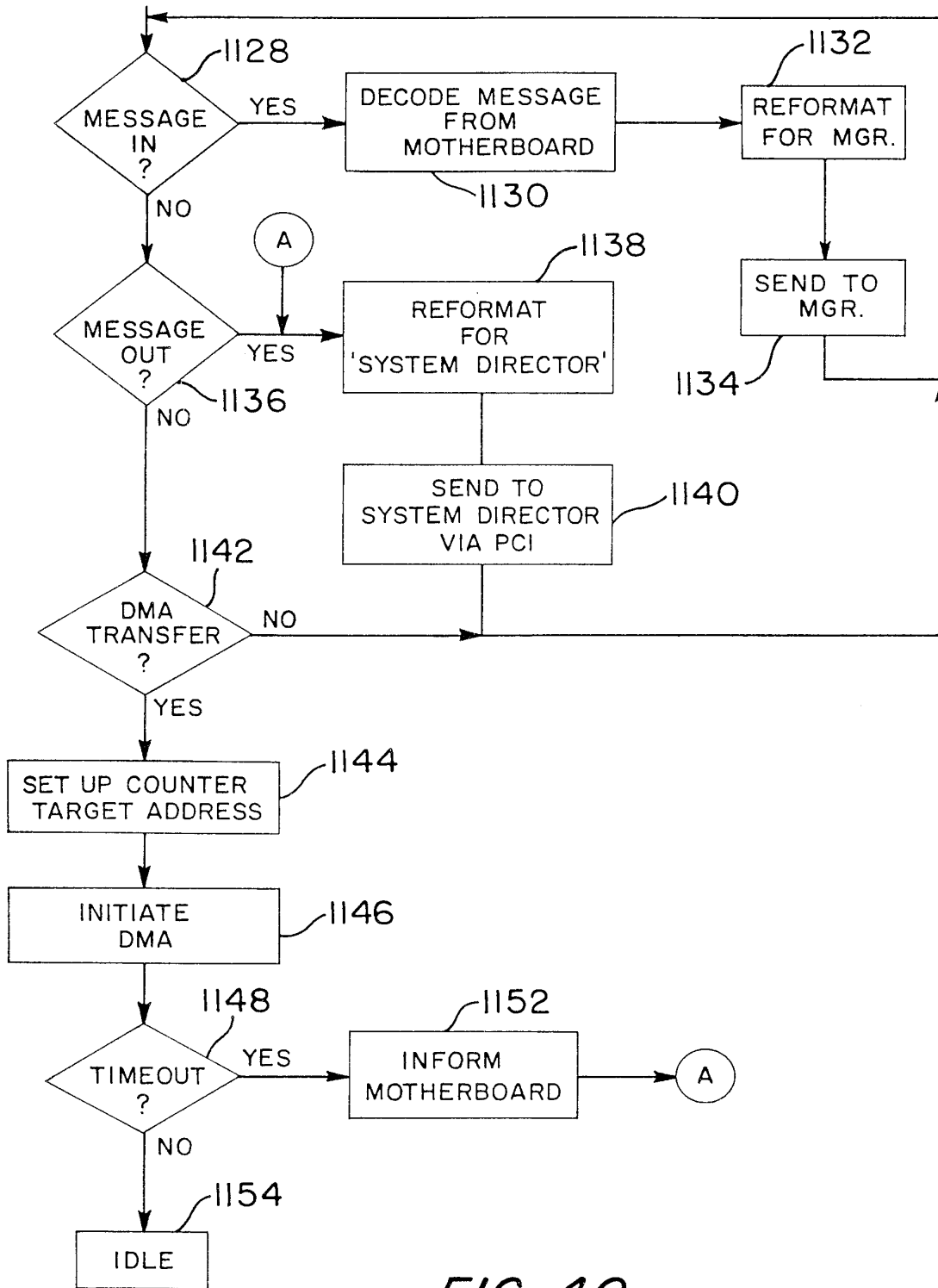
36/158



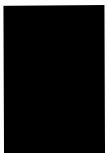
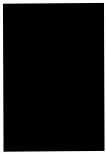
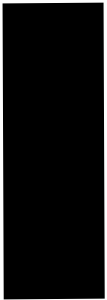
**FIG. 39A**  
MAP GENERATOR



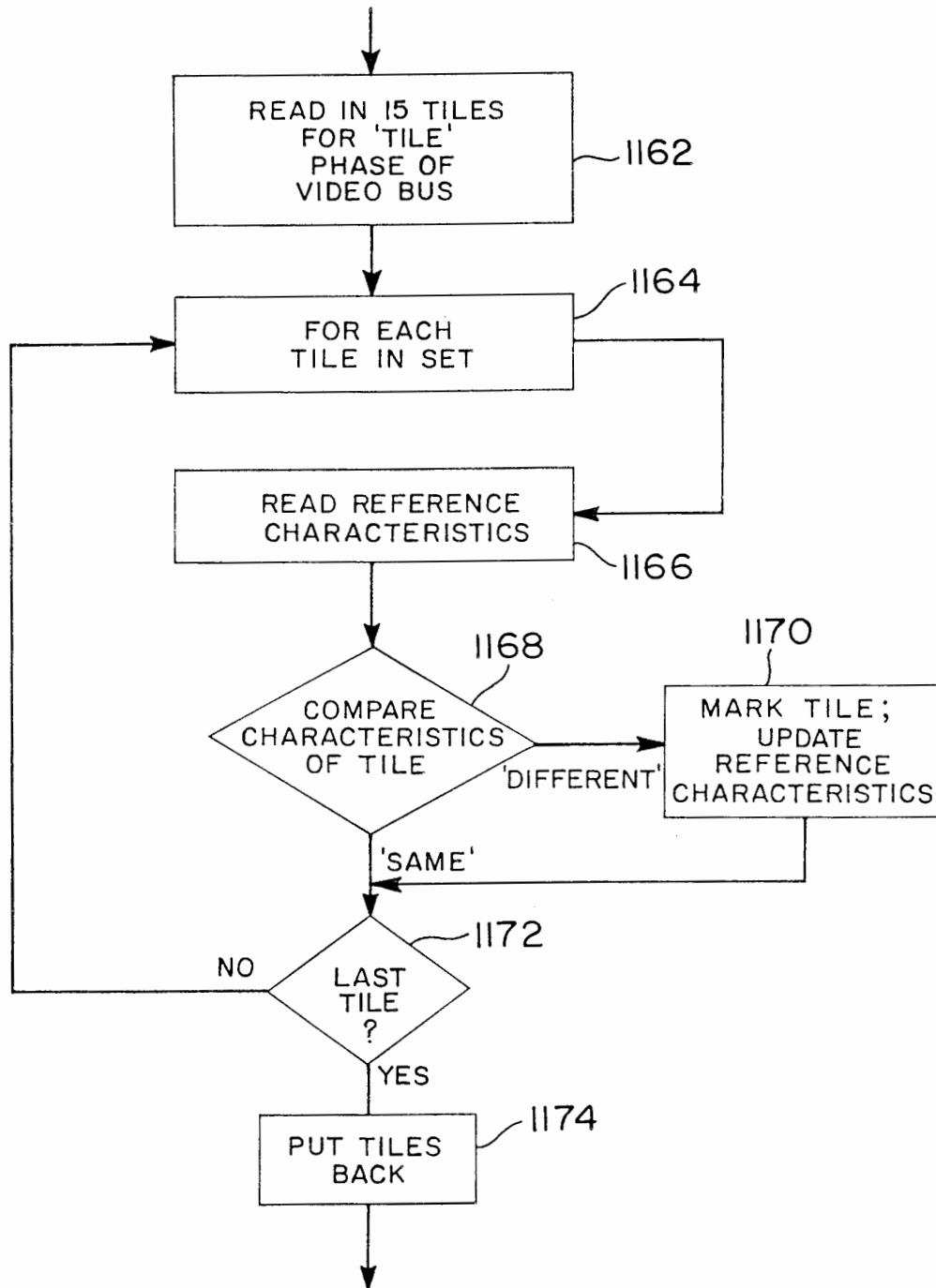
37/158



**FIG. 40**  
PCI INTERFACE DRIVER

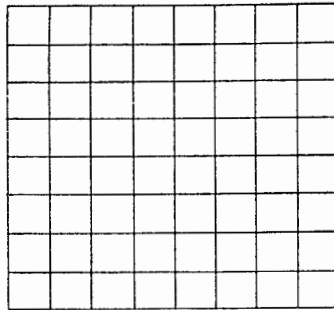


39/158

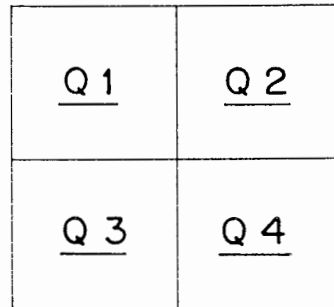


**FIG. 42**  
TILE COMPARING

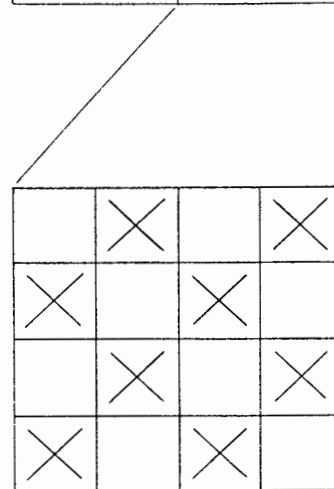
40/158



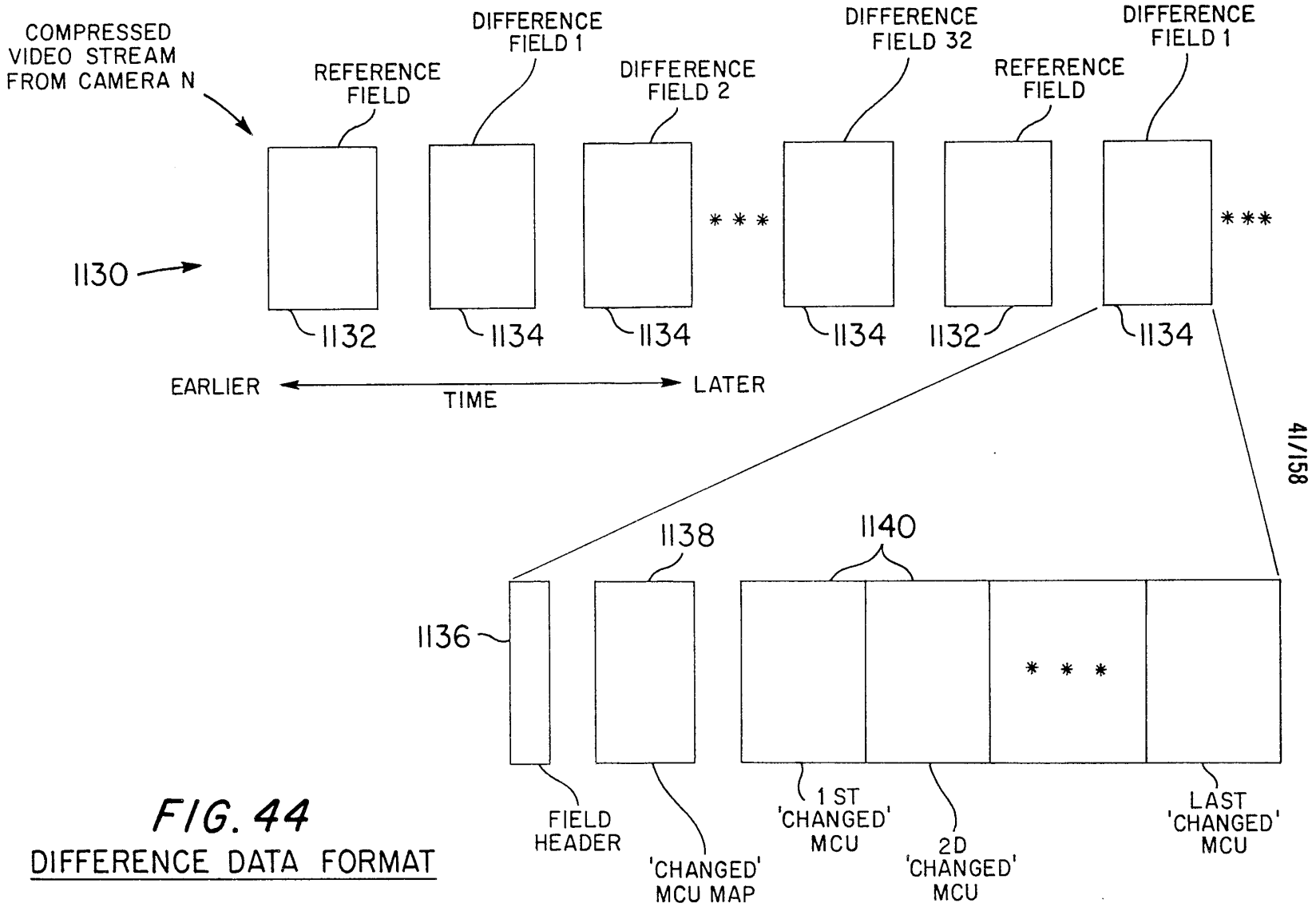
**FIG. 43A**  
TILE



**FIG. 43B**  
TILE QUADRANTS

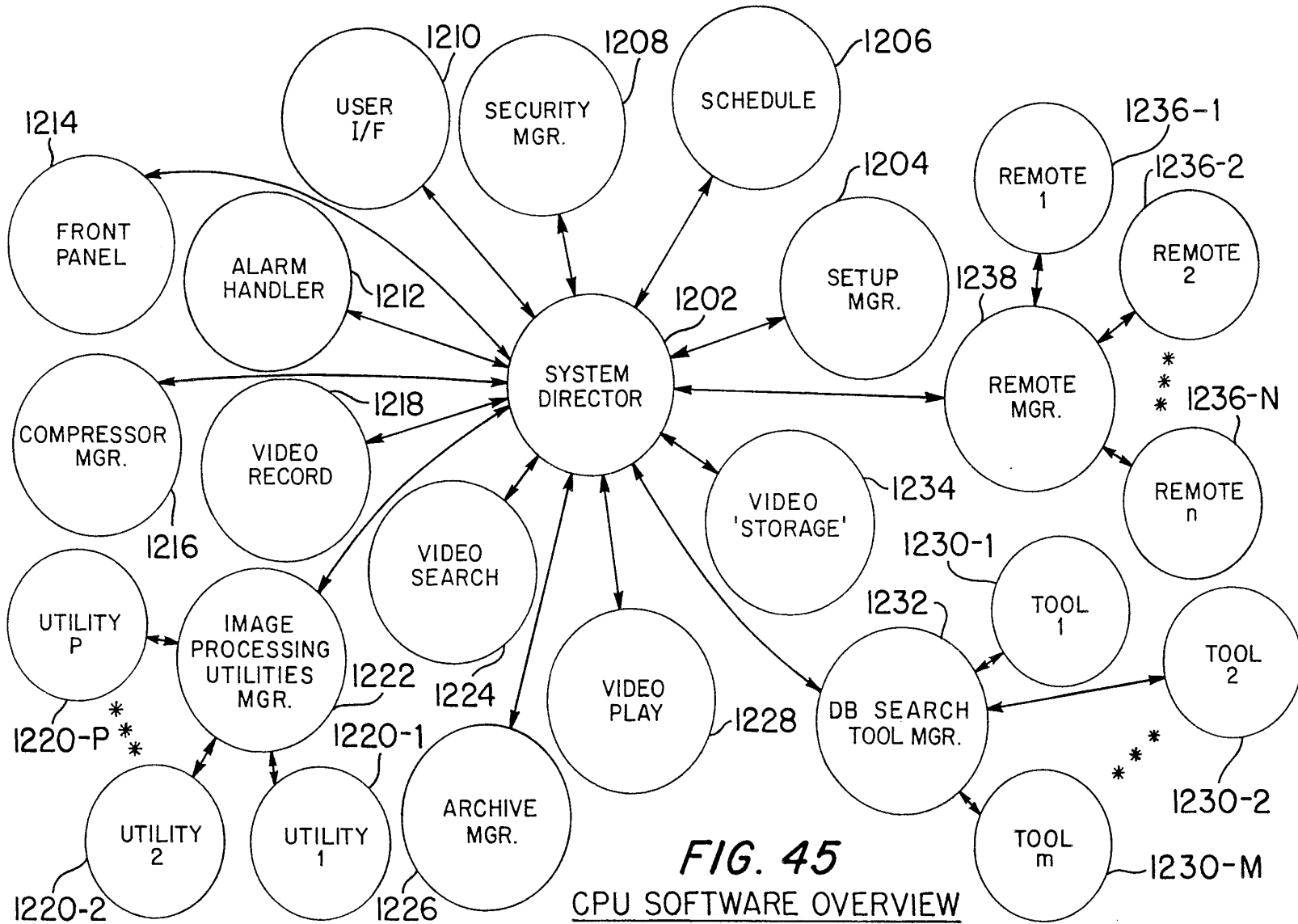


**FIG. 43C**  
'CHECKER-BOARD'  
SUBSAMPLING

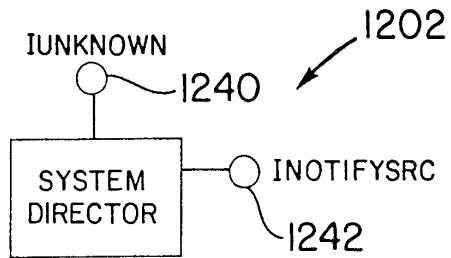


**FIG. 44**  
DIFFERENCE DATA FORMAT

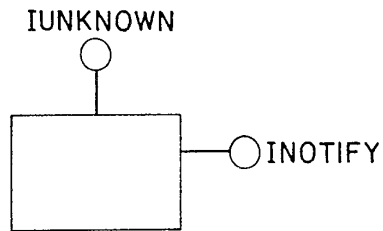
42/158



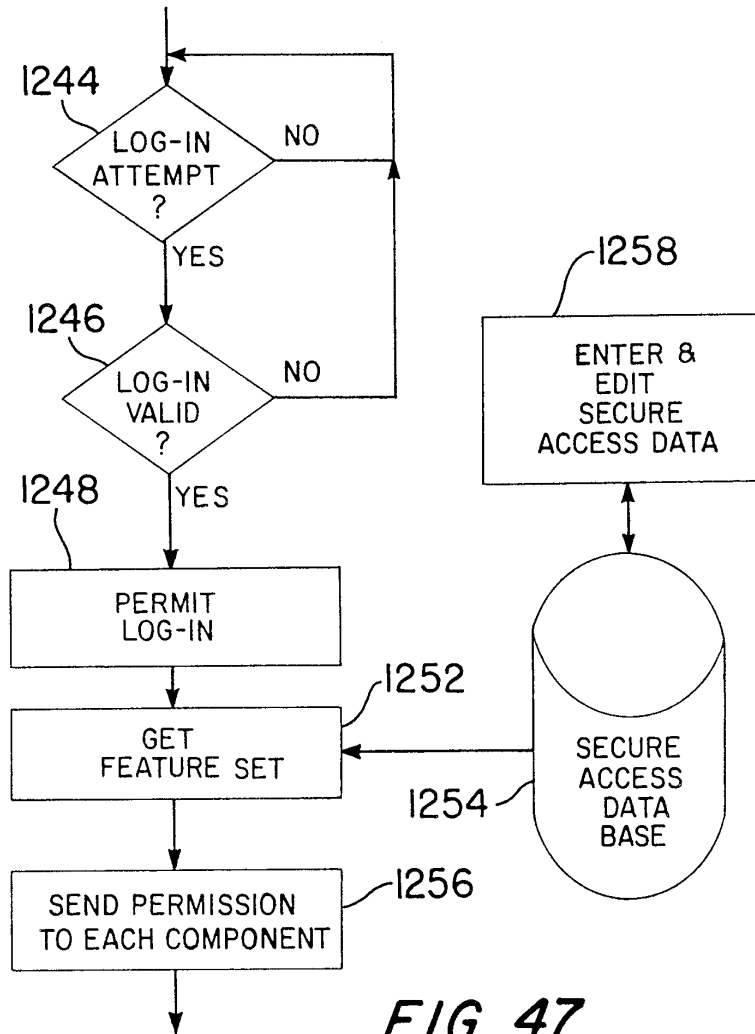
**FIG. 45**  
CPU SOFTWARE OVERVIEW



**FIG. 46A**  
SYSTEM DIRECTOR OBJECT

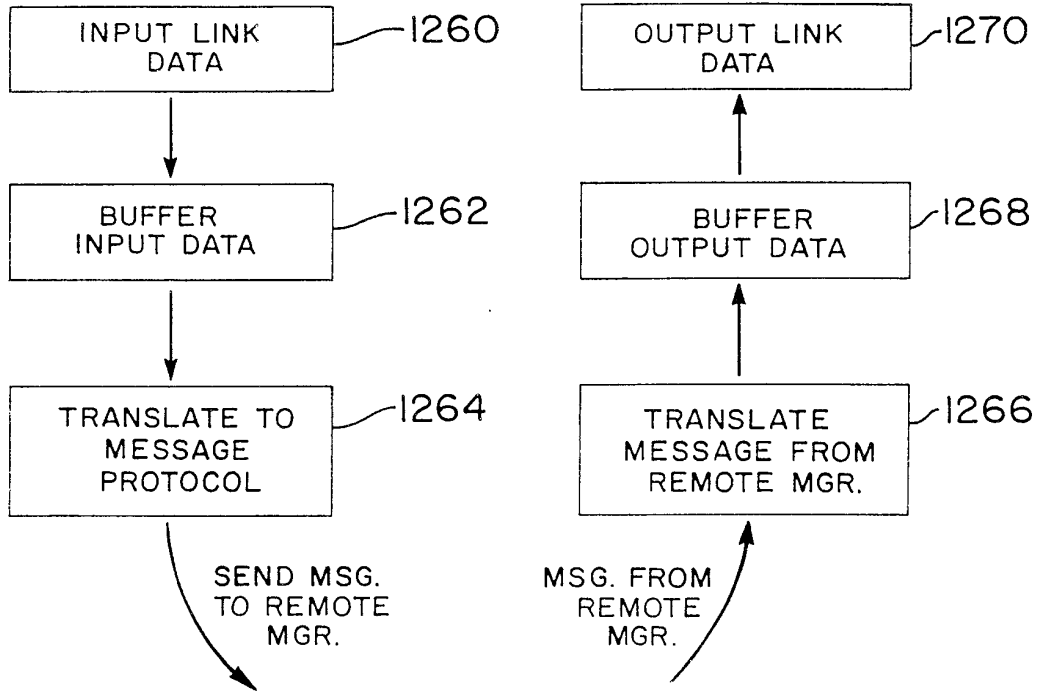


**FIG. 46B**  
OTHER S/W COMPONENTS

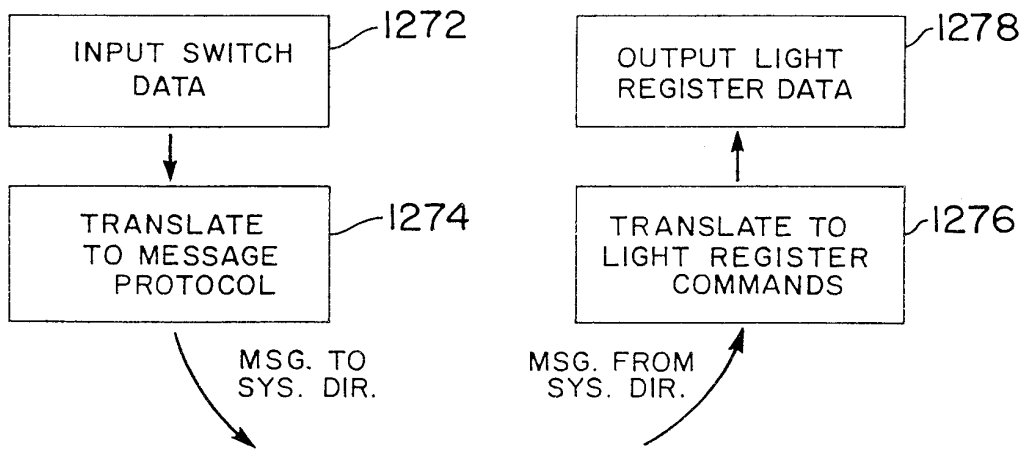


**FIG. 47**  
SECURITY MGR.

44/158

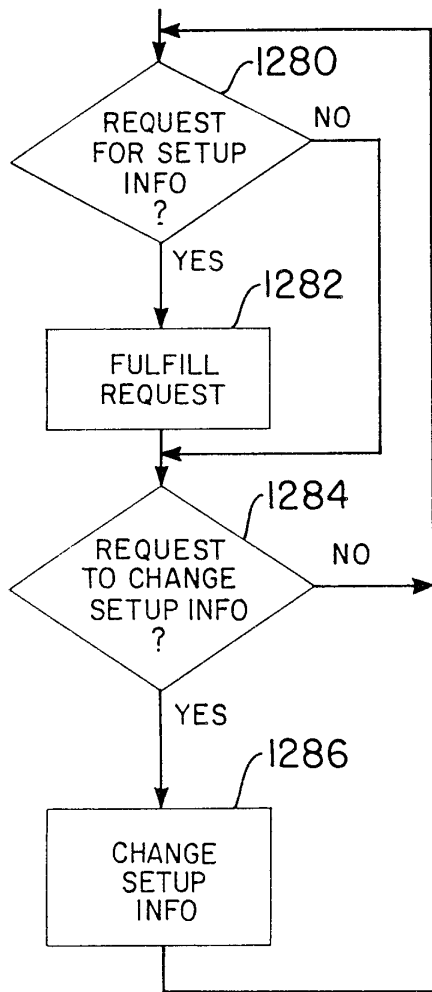


**FIG. 48**  
REMOTE OBJECT INSTANCE

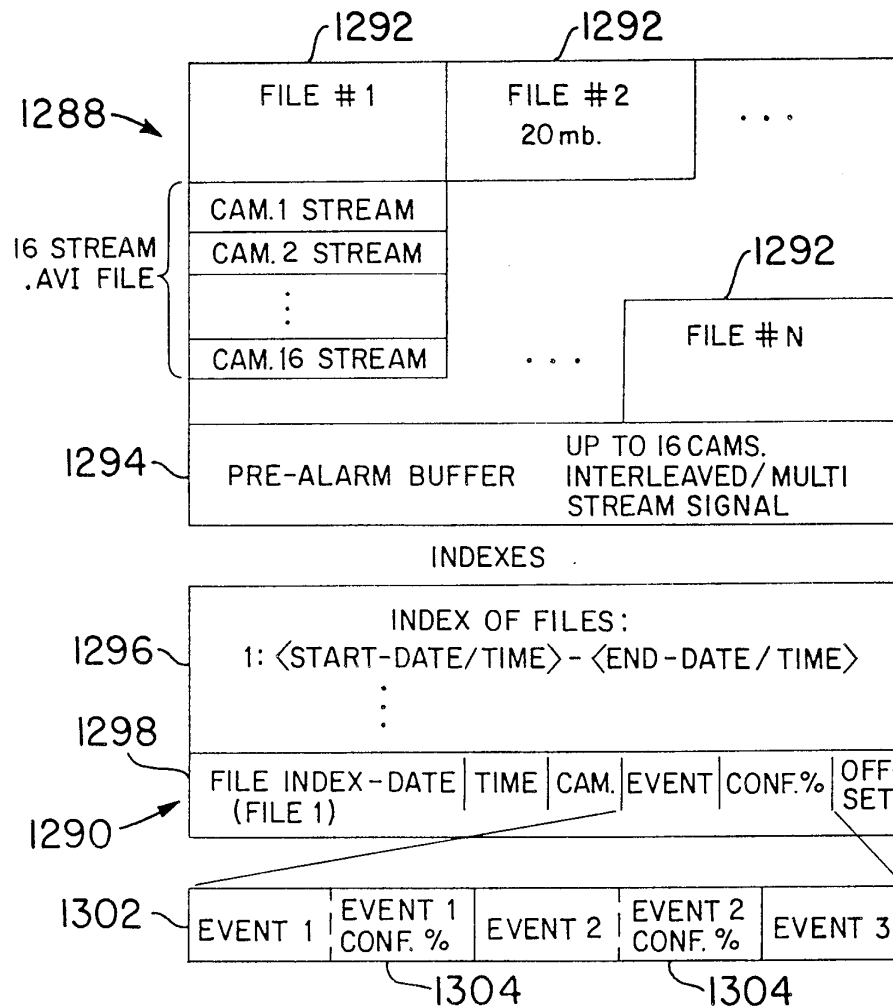


**FIG. 49**  
FRONT PANEL  
(SOFTWARE OBJECT)





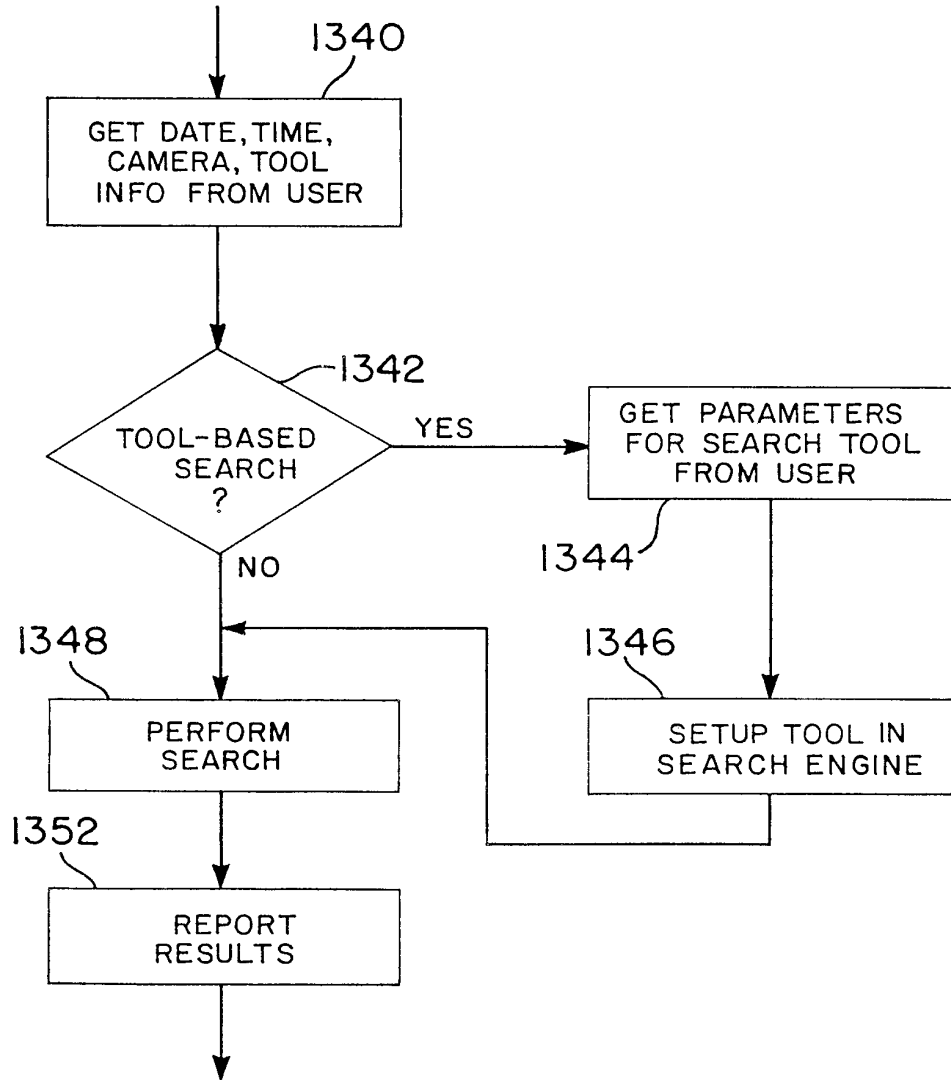
**FIG. 50**  
**SETUP MGR.**



**FIG. 51**  
**VIDEO DATA FORMAT ON DISK**

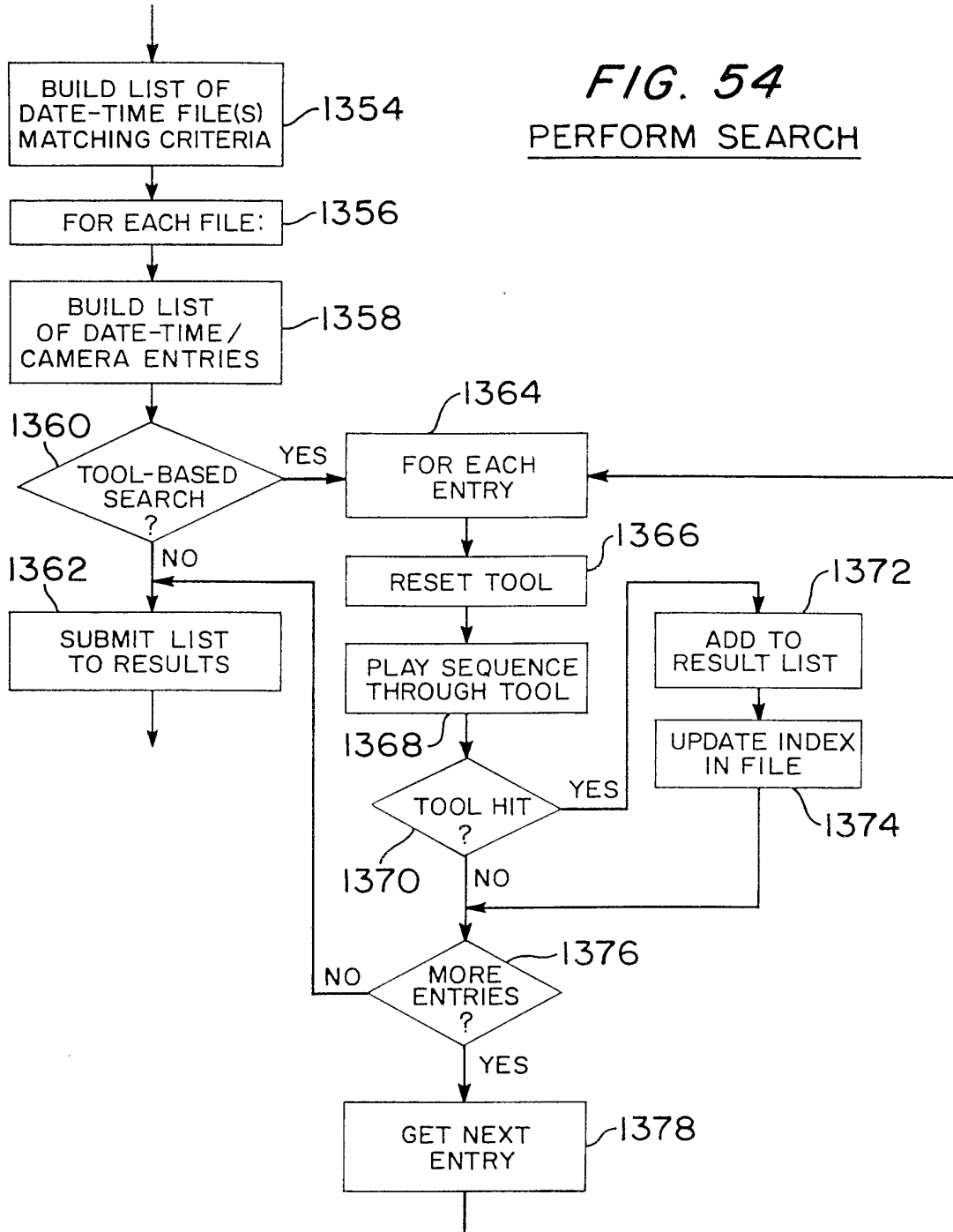


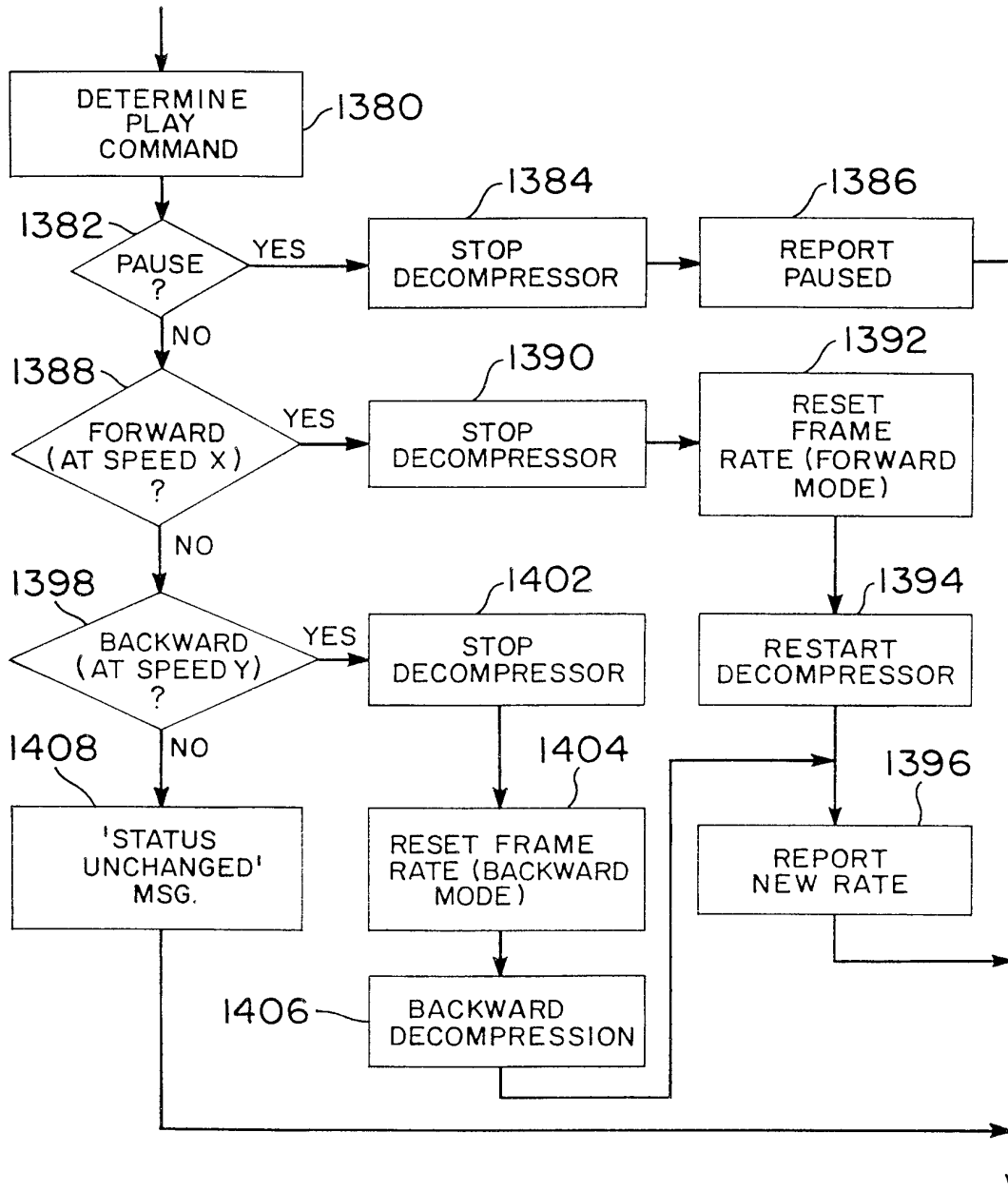
47/158



**FIG. 53**  
VIDEO SEARCH

**FIG. 54**  
PERFORM SEARCH

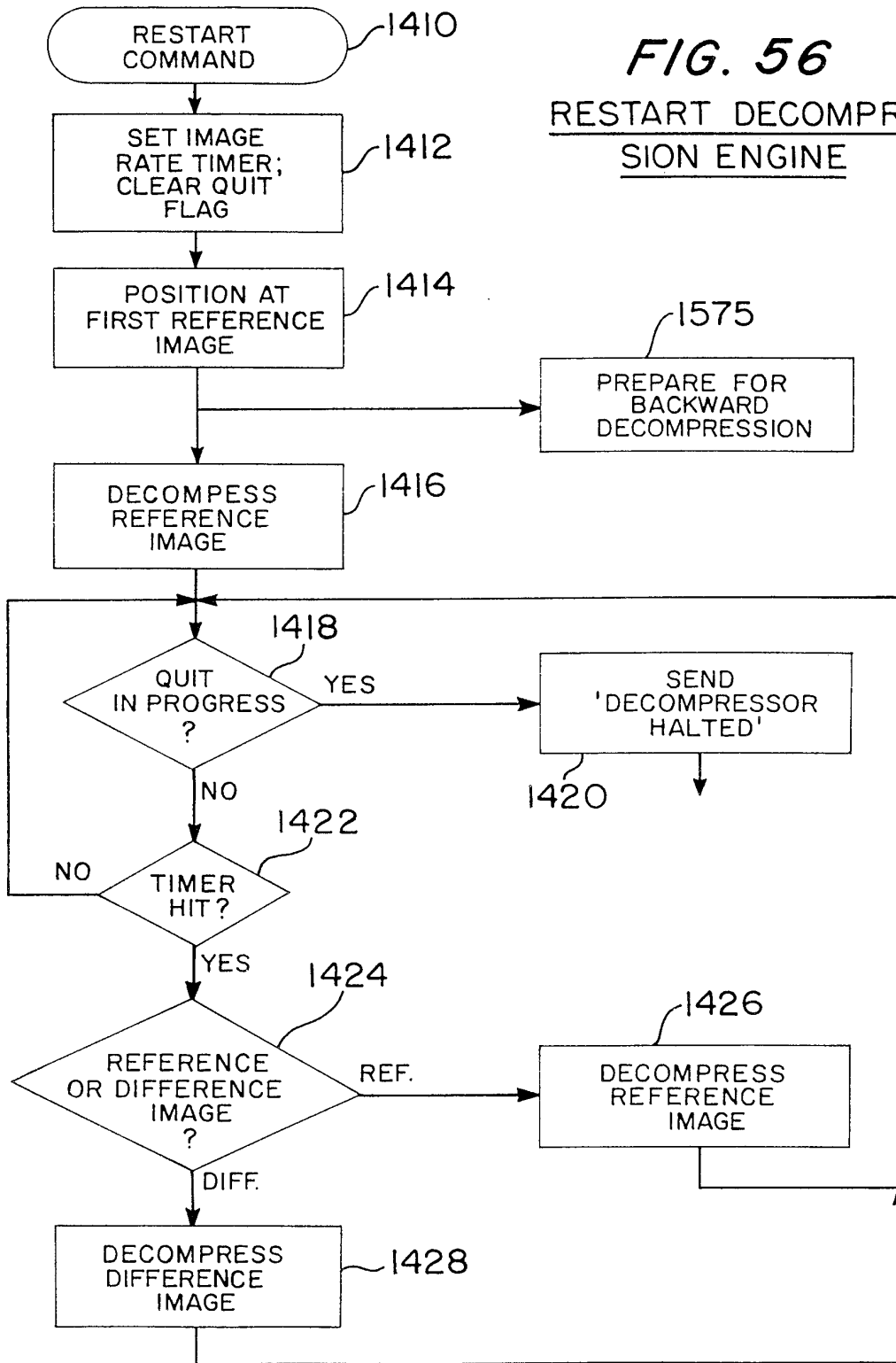


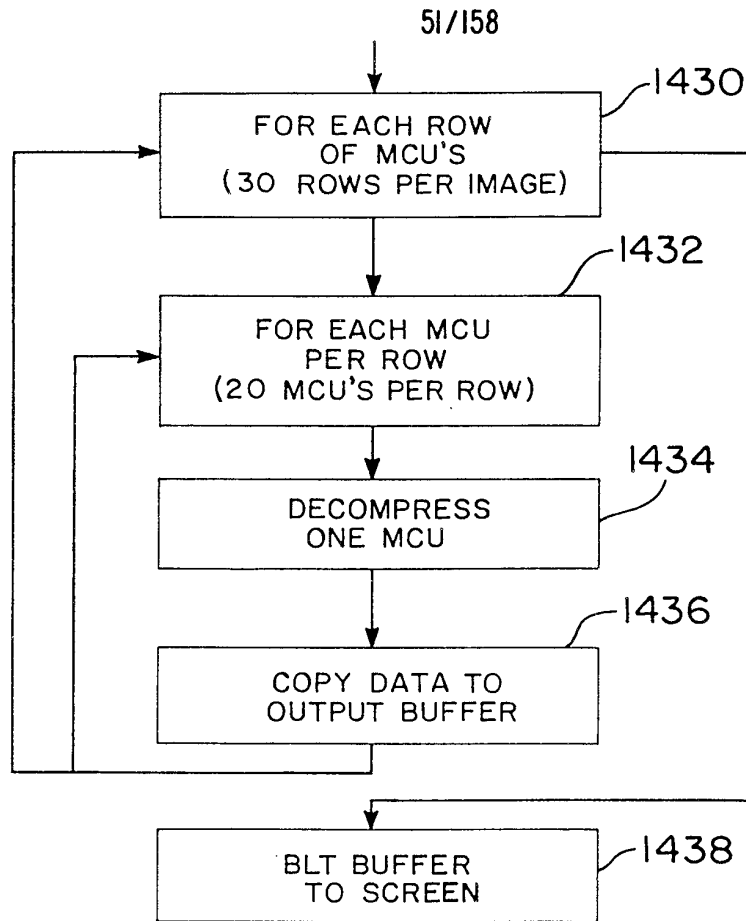


**FIG. 55**  
VIDEO PLAY

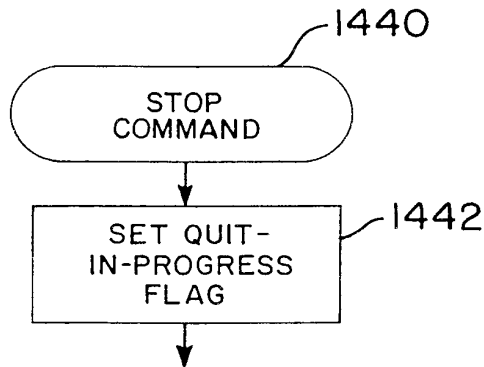
50/158

**FIG. 56**  
RESTART DECOMPRESSION ENGINE

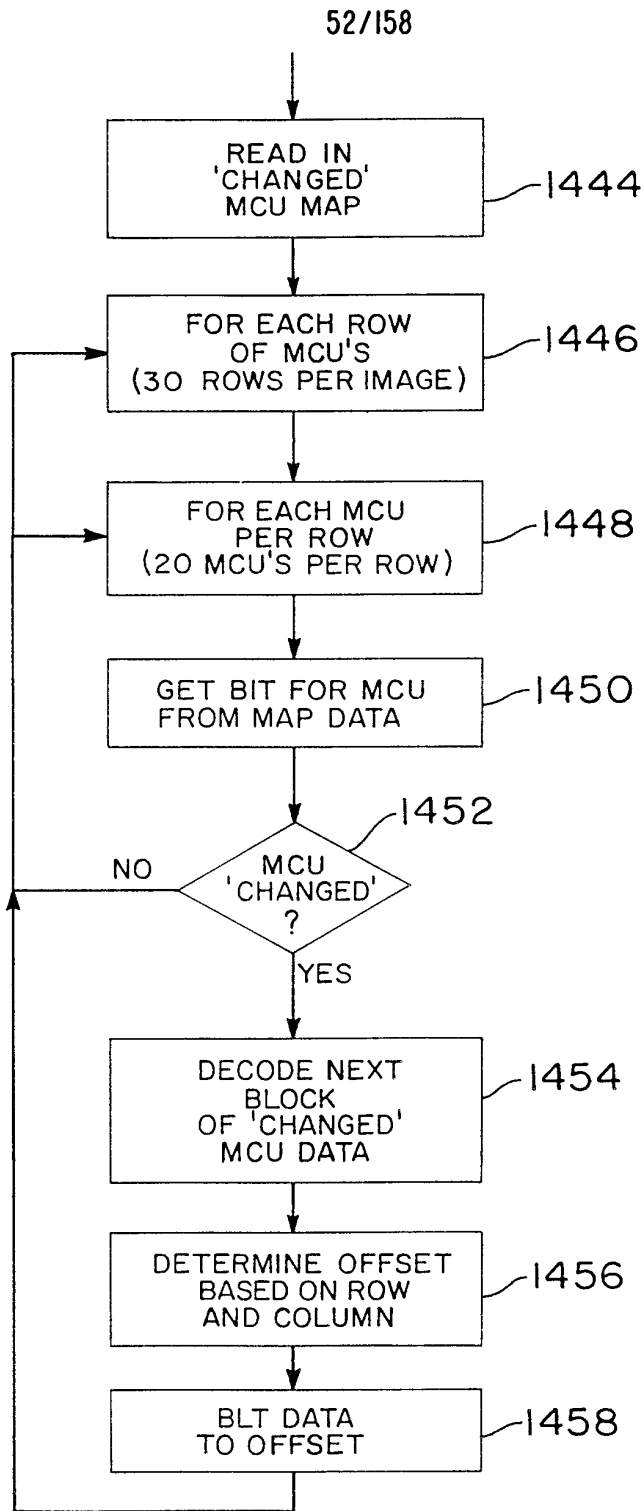




**FIG. 57**  
DECOMPRESS REFERENCE IMAGE



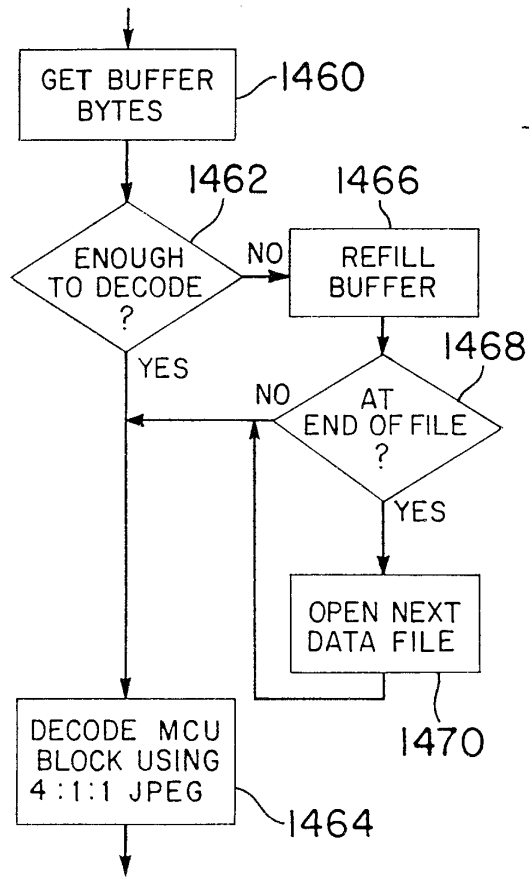
**FIG. 58**  
STOP DECOMPRESSOR



**FIG. 59**

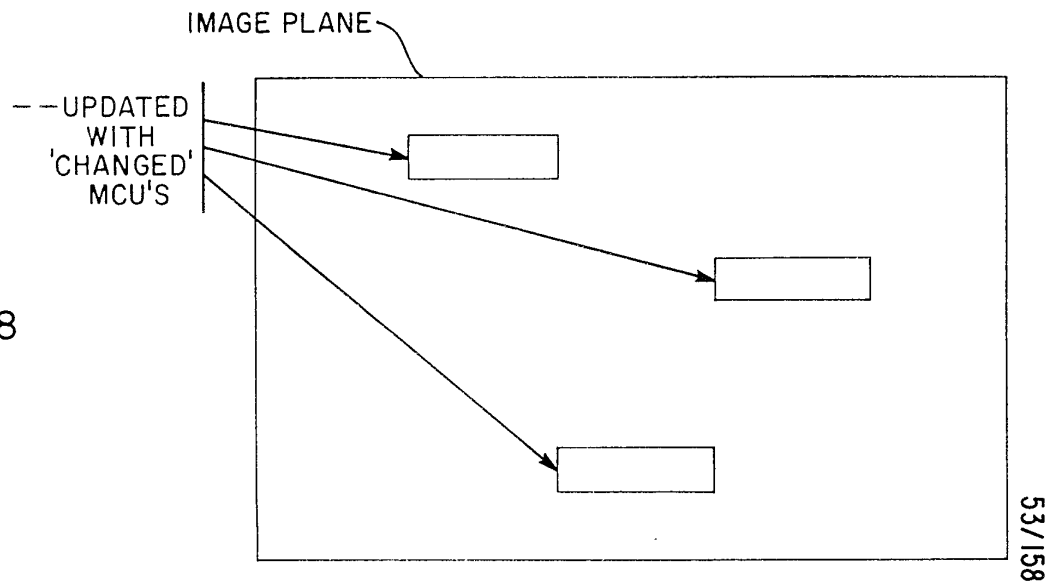
DECOMPRESS DIFFERENCE IMAGE





**FIG. 60**

DECODE 'CHANGED' MCU BLOCK



**FIG. 61**

DECOMPRESSION USES 'POSTAGE STAMPS'

54/158

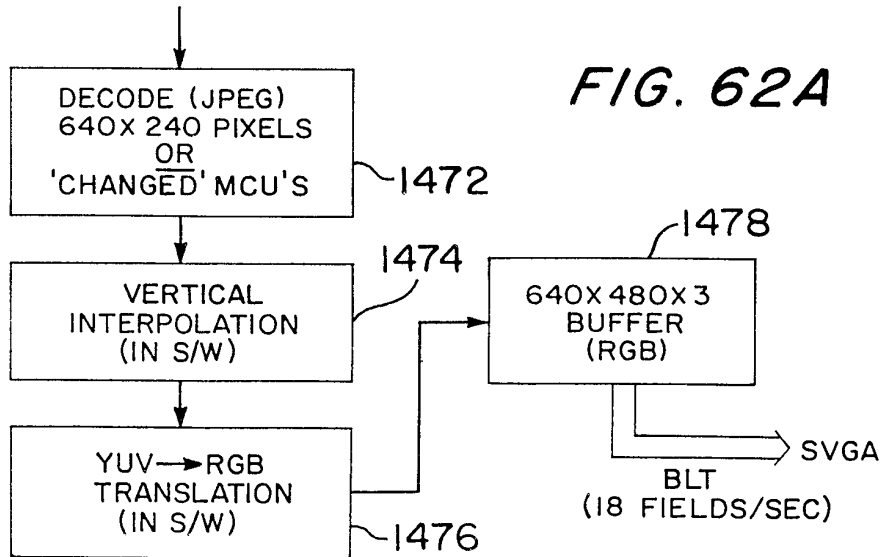


FIG. 62A

VIDEO DATA REFRESH – PLAYBACK

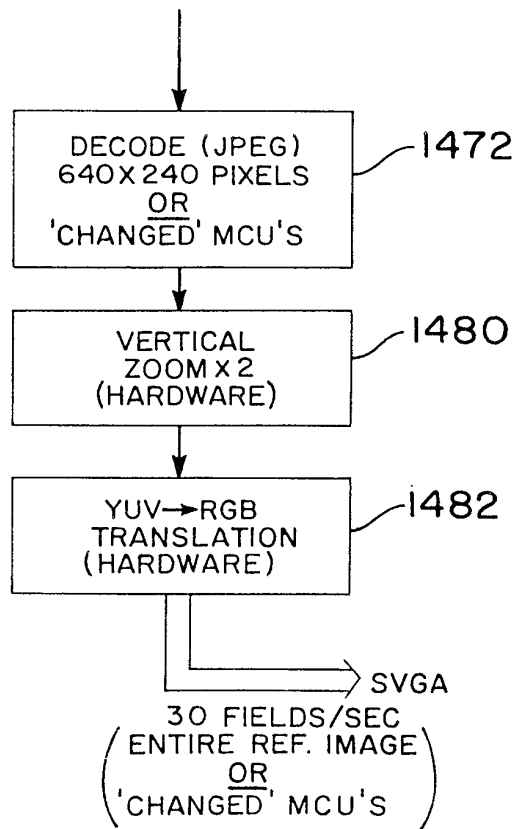
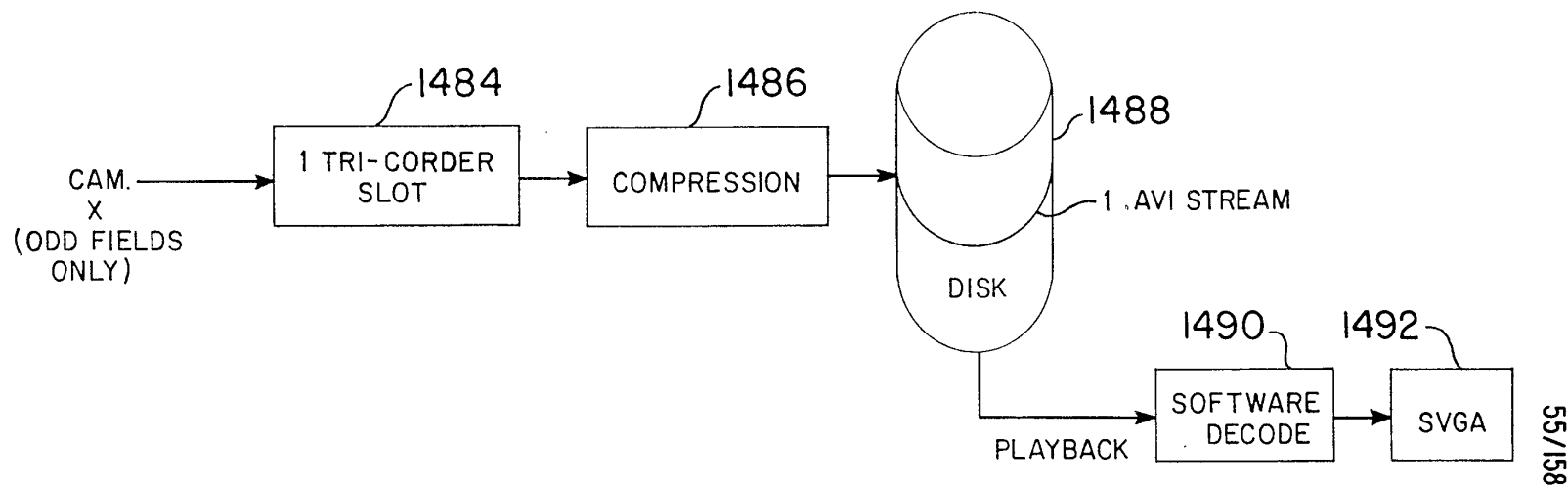


FIG. 62B



**FIG. 63A**

VERTICAL RESOLUTION  
OPTIONS-PLAYBACK

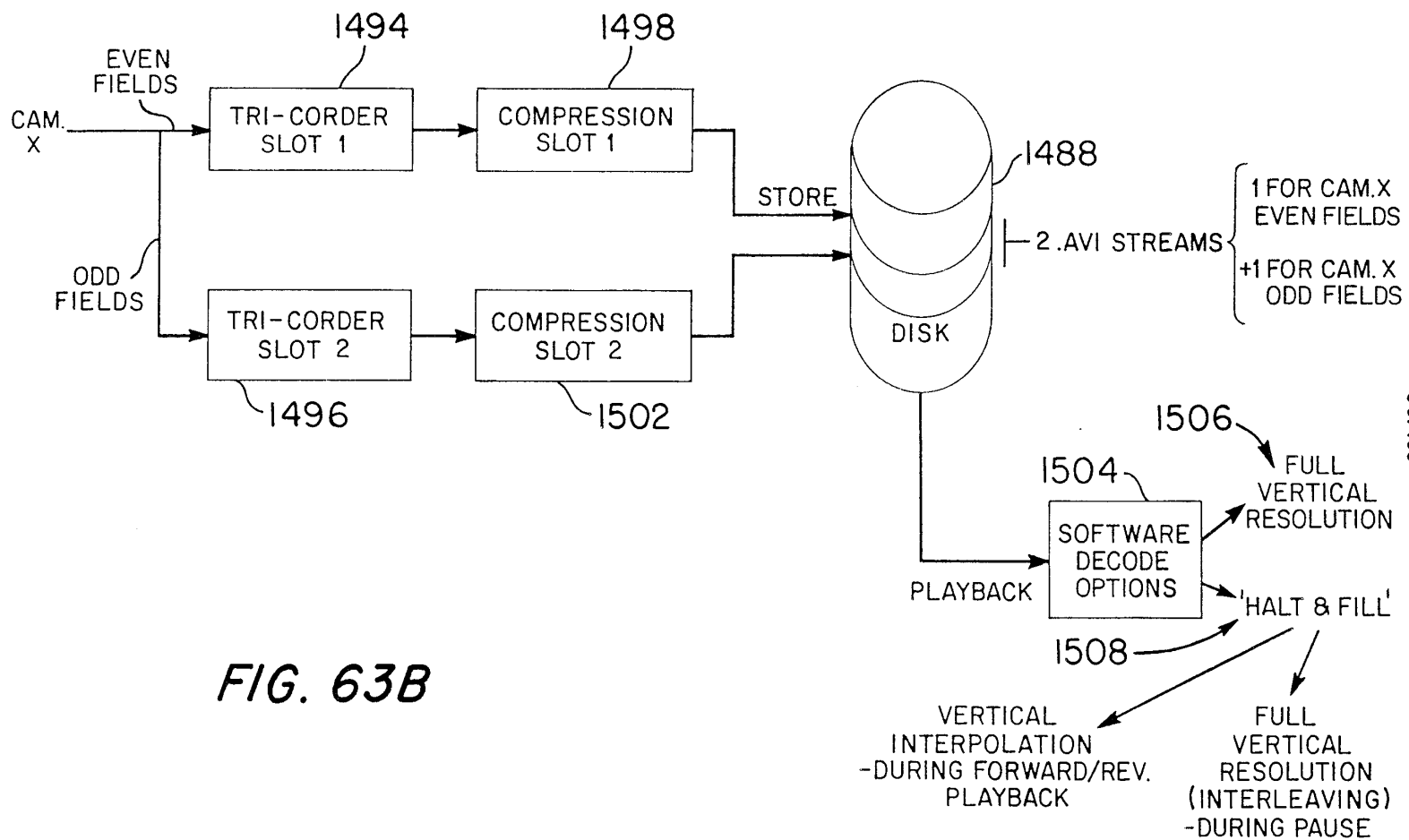
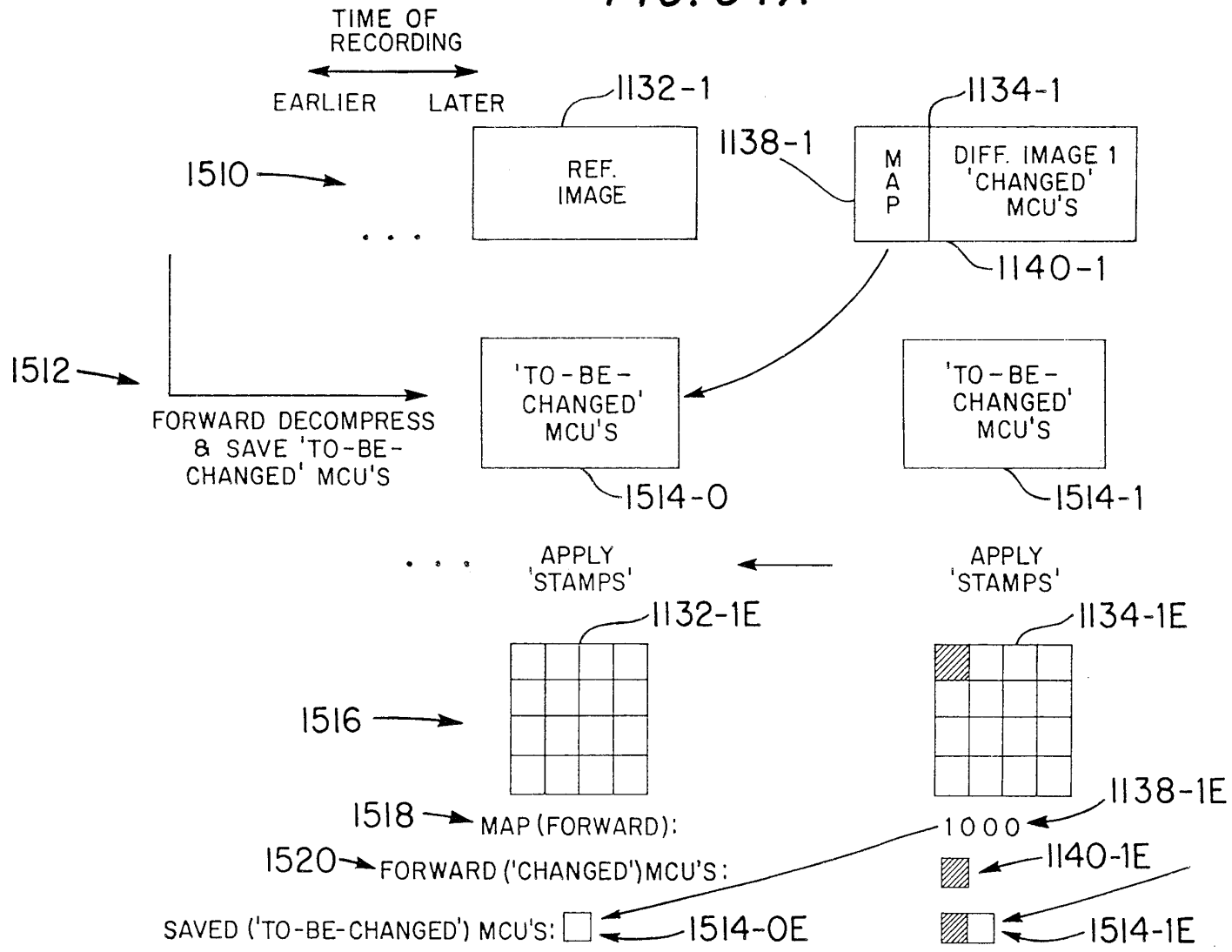


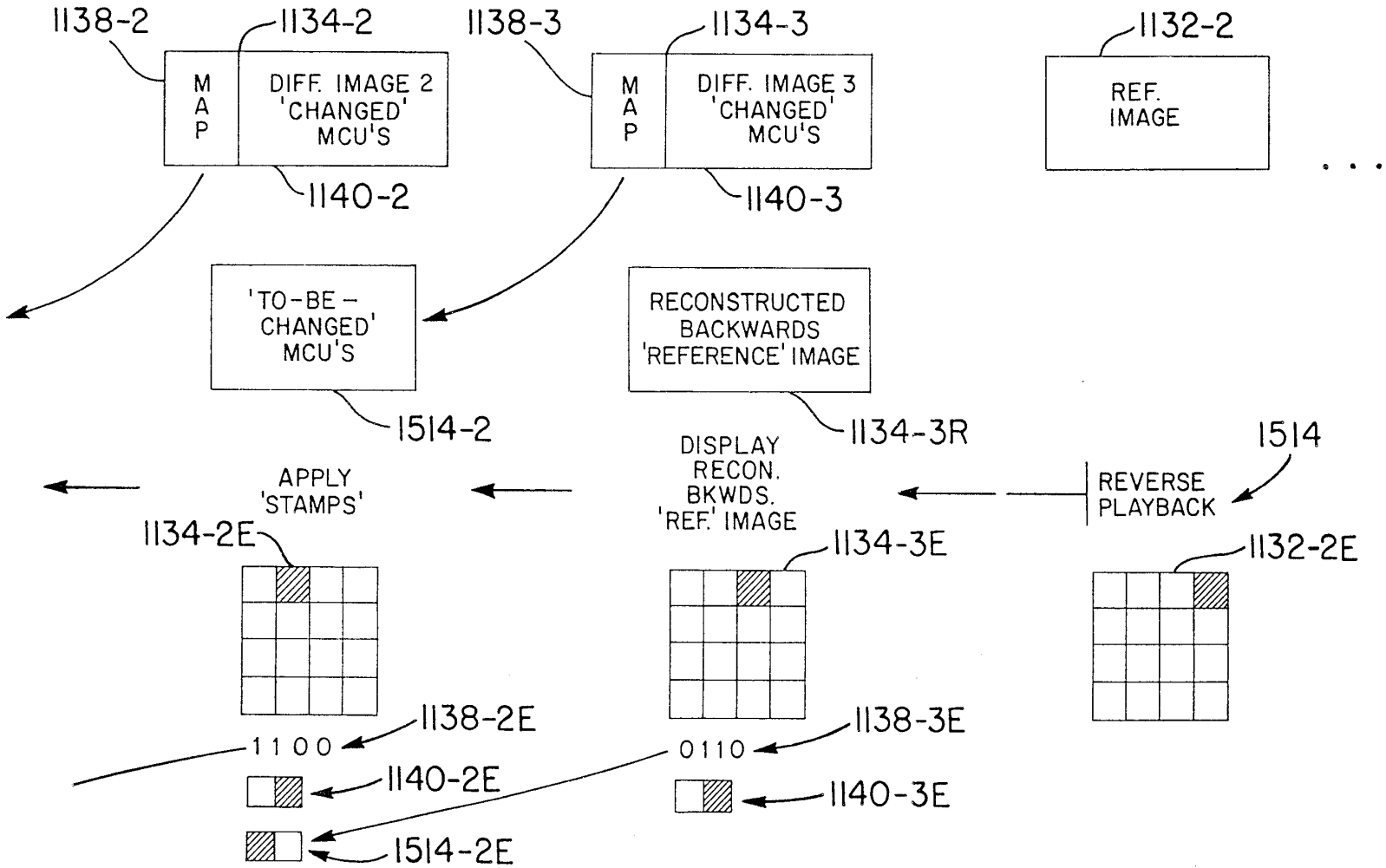
FIG. 63B

FIG. 64A



**FIG. 64B**

PICTORIAL ILLUSTRATION OF BACKWARDS DECOMPRESSION

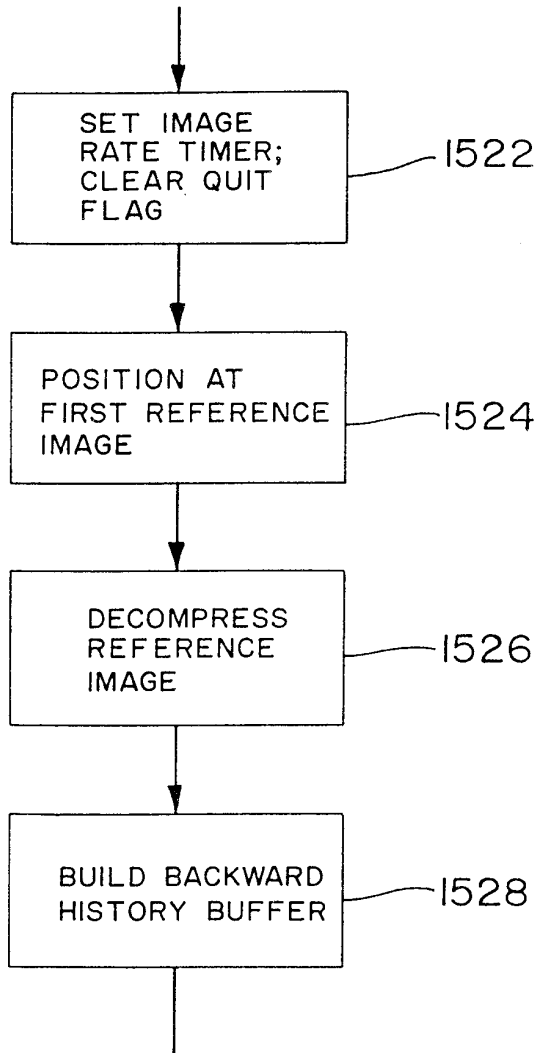


WO 98/19450

58/158

PCT/US97/17886

59/158



**FIG. 65A**  
BACKWARD DECOMPRESSION

60/158

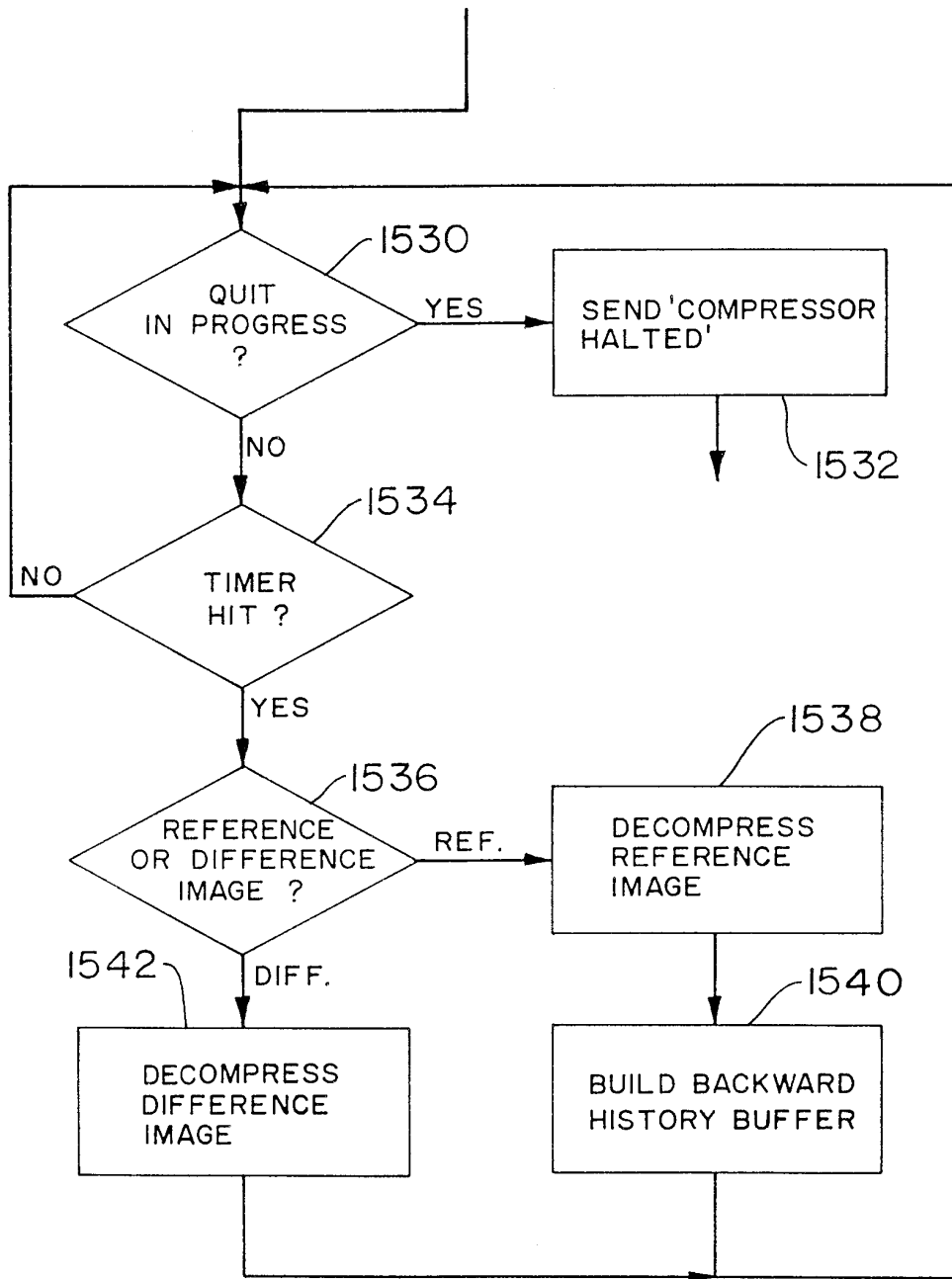
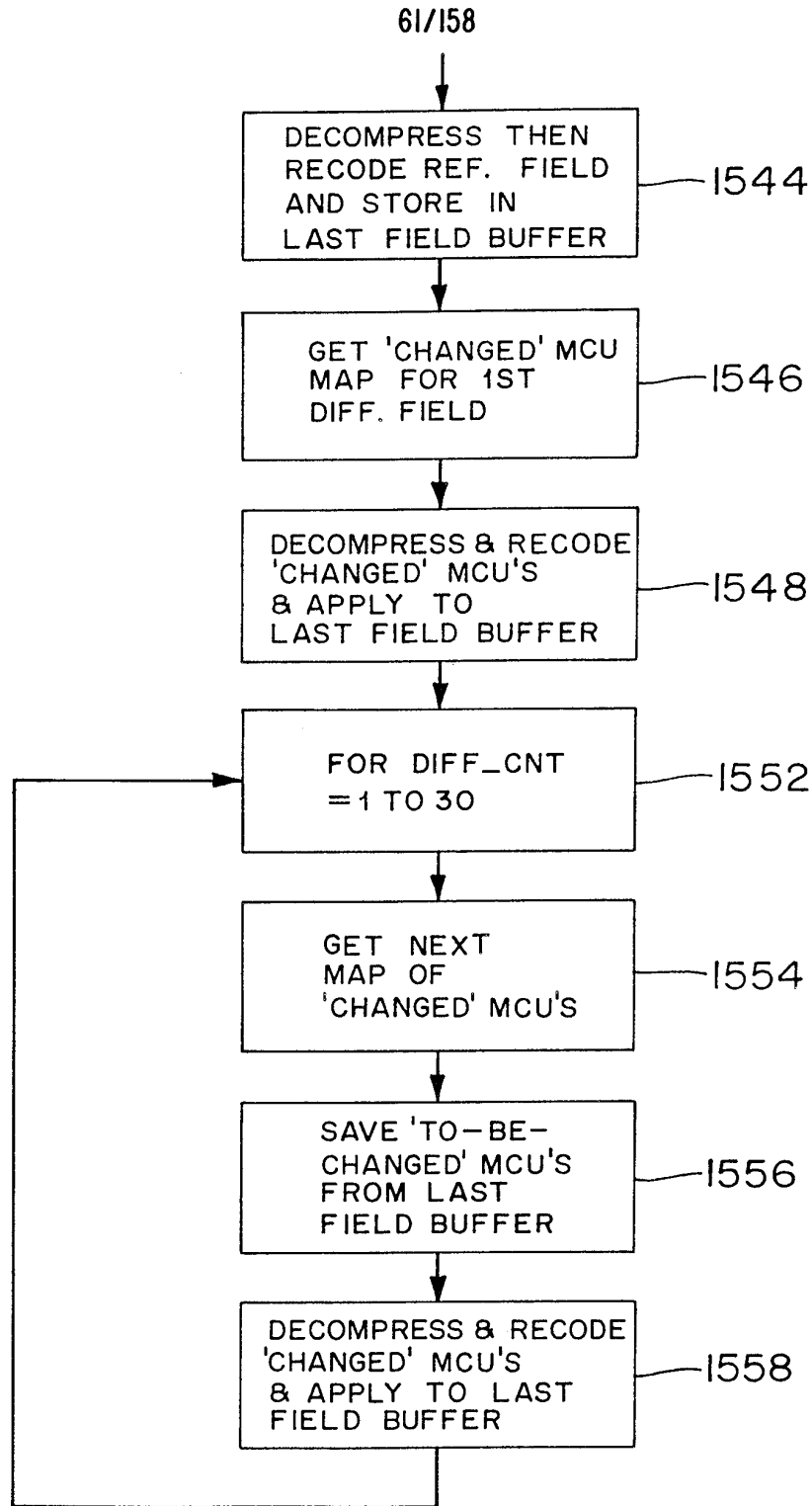
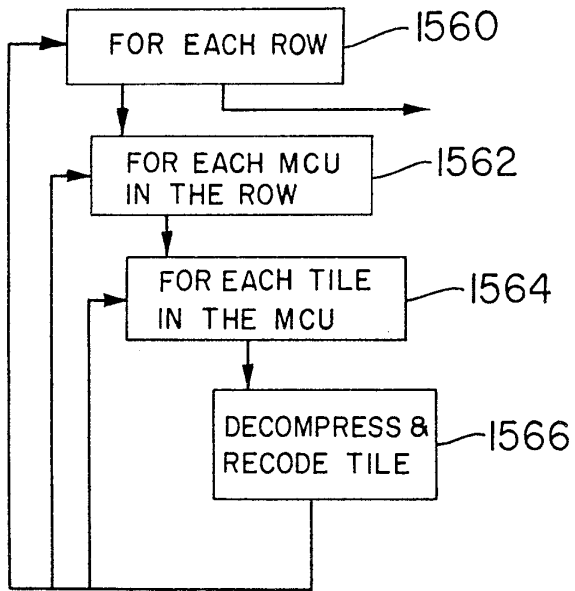


FIG. 65B

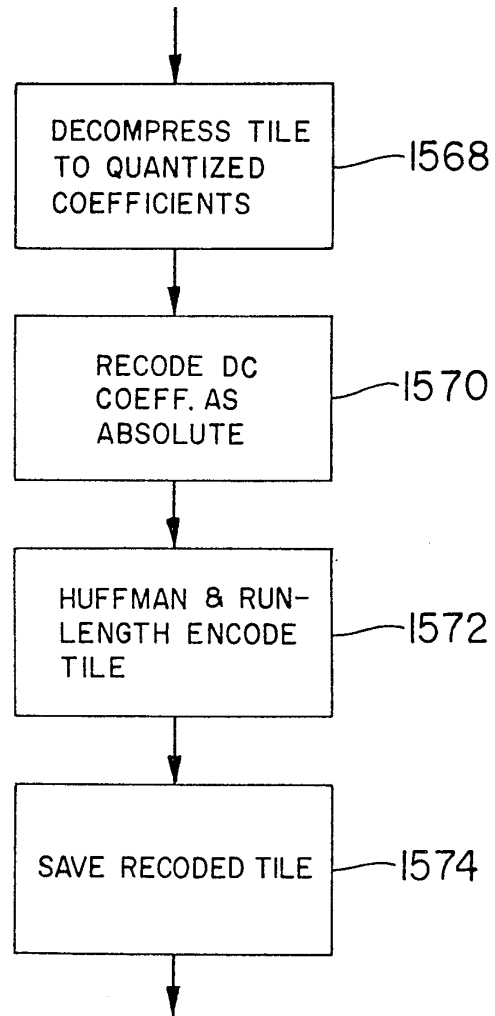




**FIG. 66** BUILD BACKWARD HISTORY BUFFER

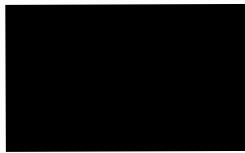


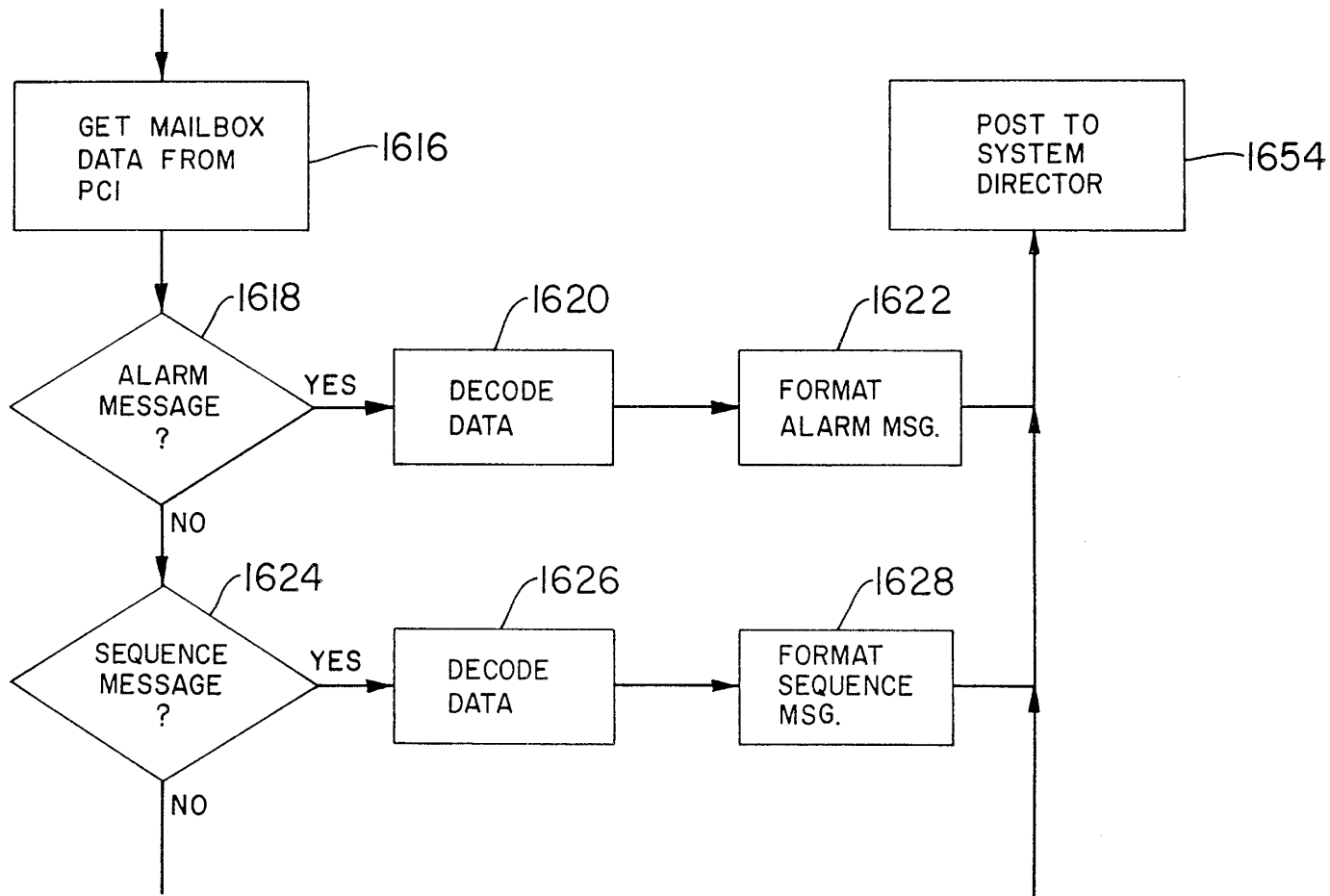
**FIG. 67**  
DECOMPRESS/RECODE  
REF. FIELD



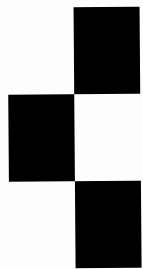
**FIG. 68**  
DECOMPRESS & RECODE TILE

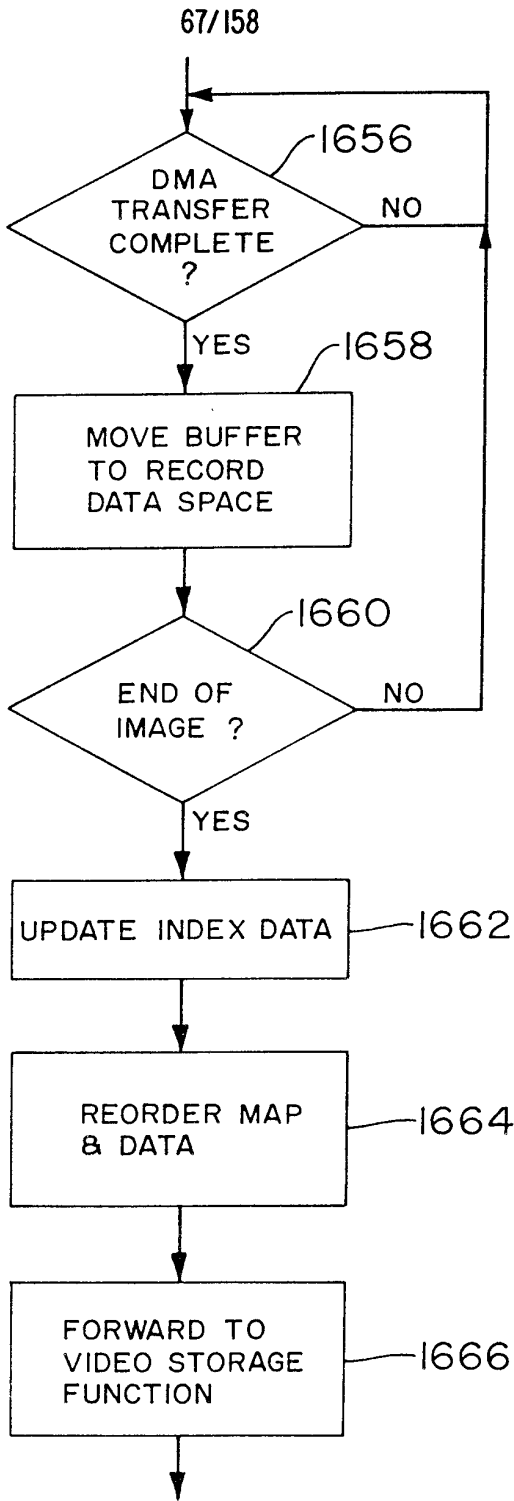




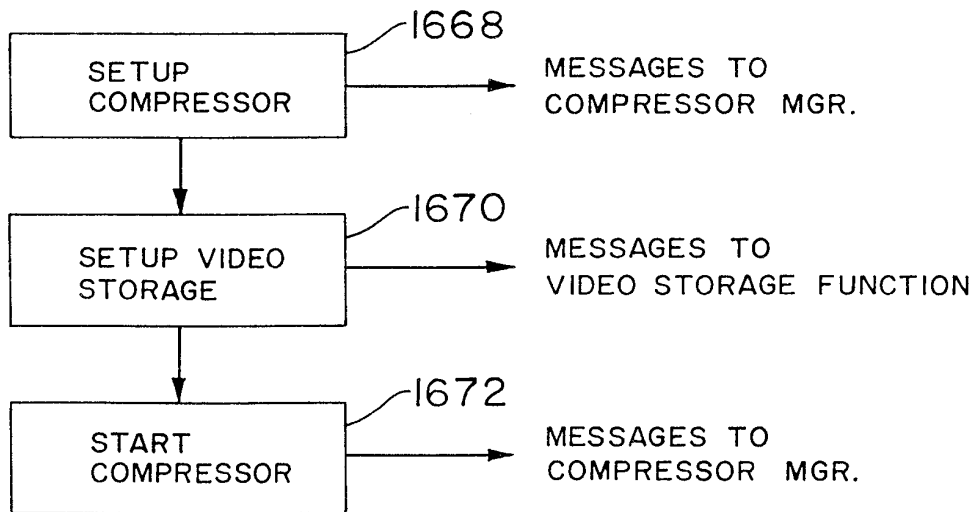
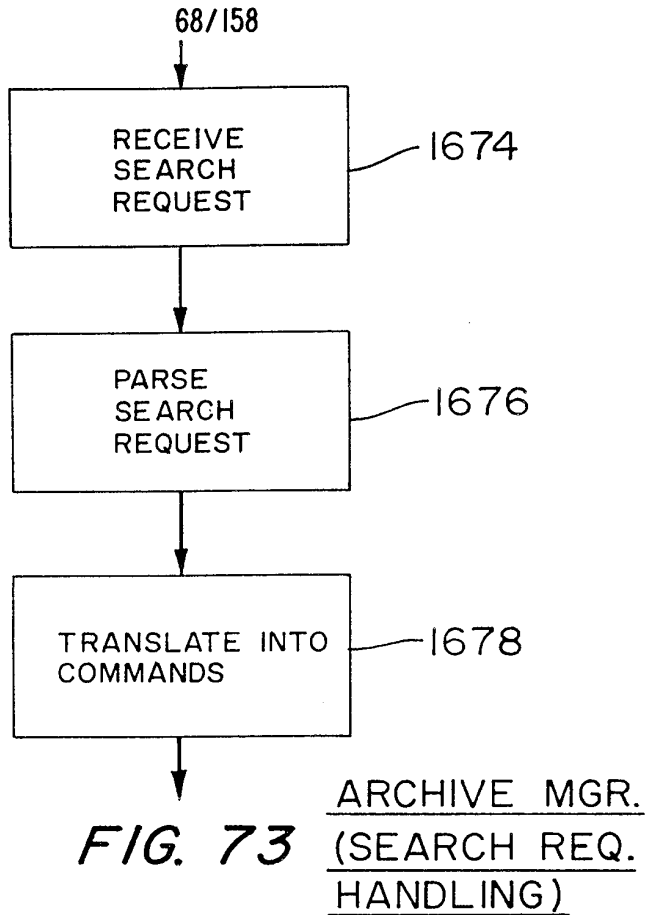


**FIG. 70A**  
COMPRESSOR MGR.  
(STATUS MSG. HANDLING)



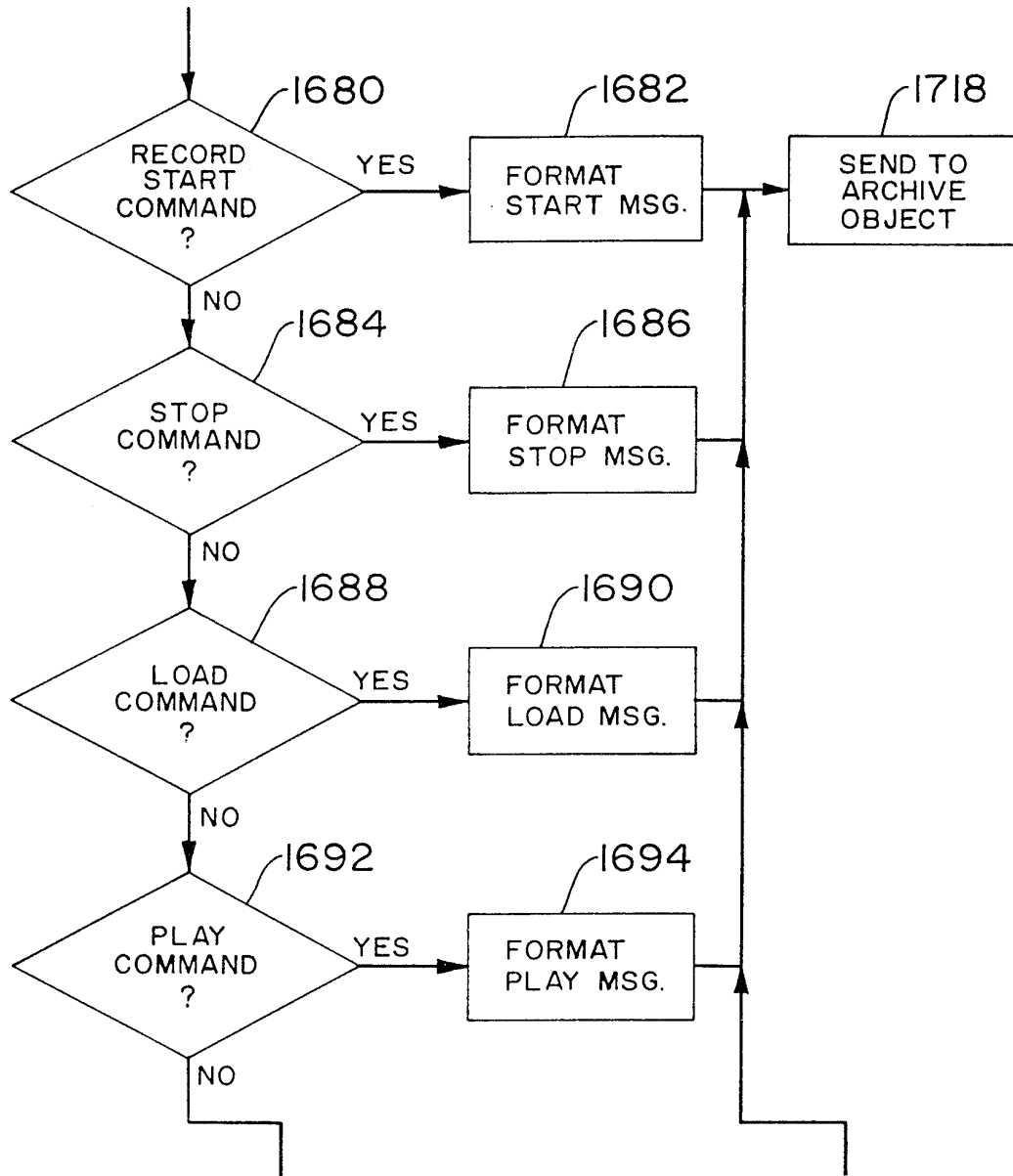


**FIG. 71**  
COMPRESSOR MGR.  
(VIDEO DATA HANDLING)



**FIG. 72**  
VIDEO RECORD FUNCTION





**FIG. 74A**  
ARCHIVE MGR.  
(COMMAND HANDLING)

70/158

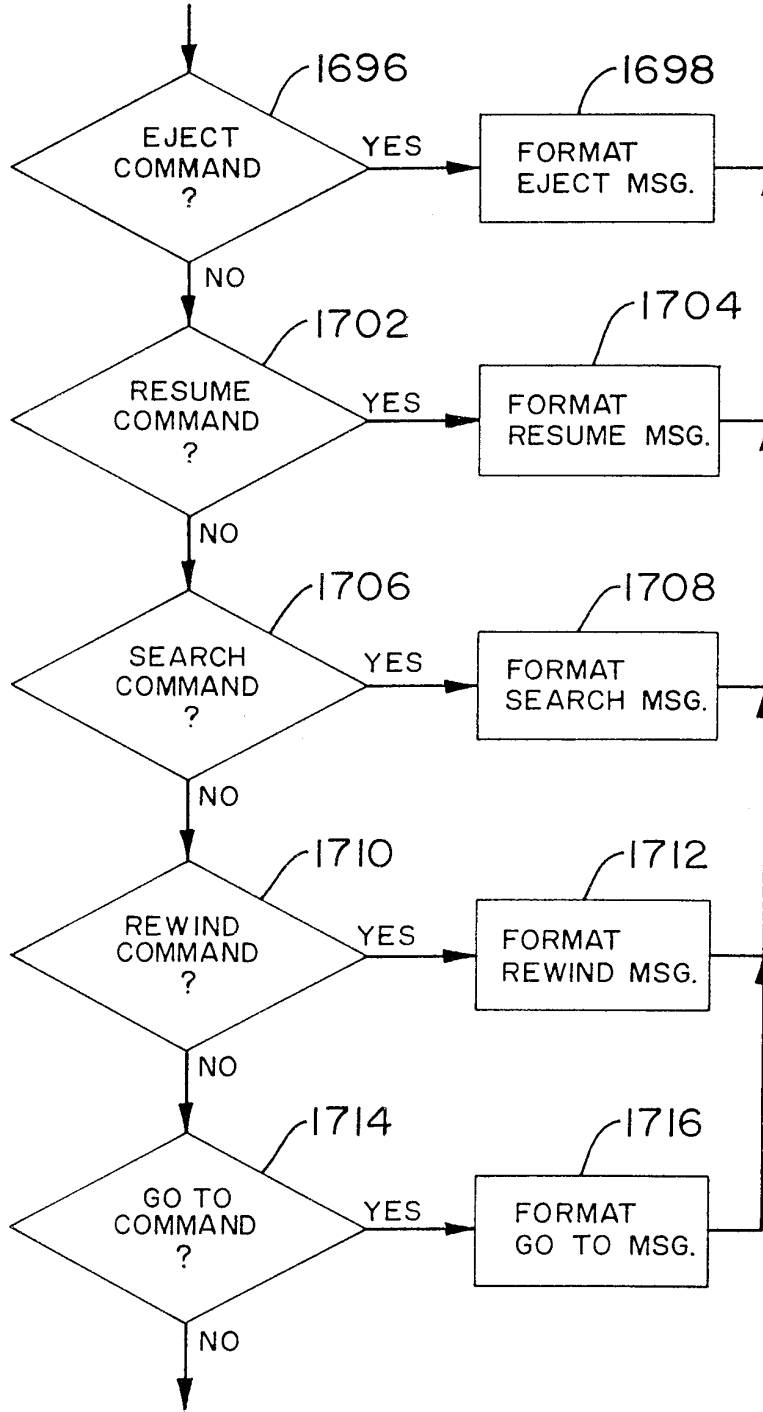
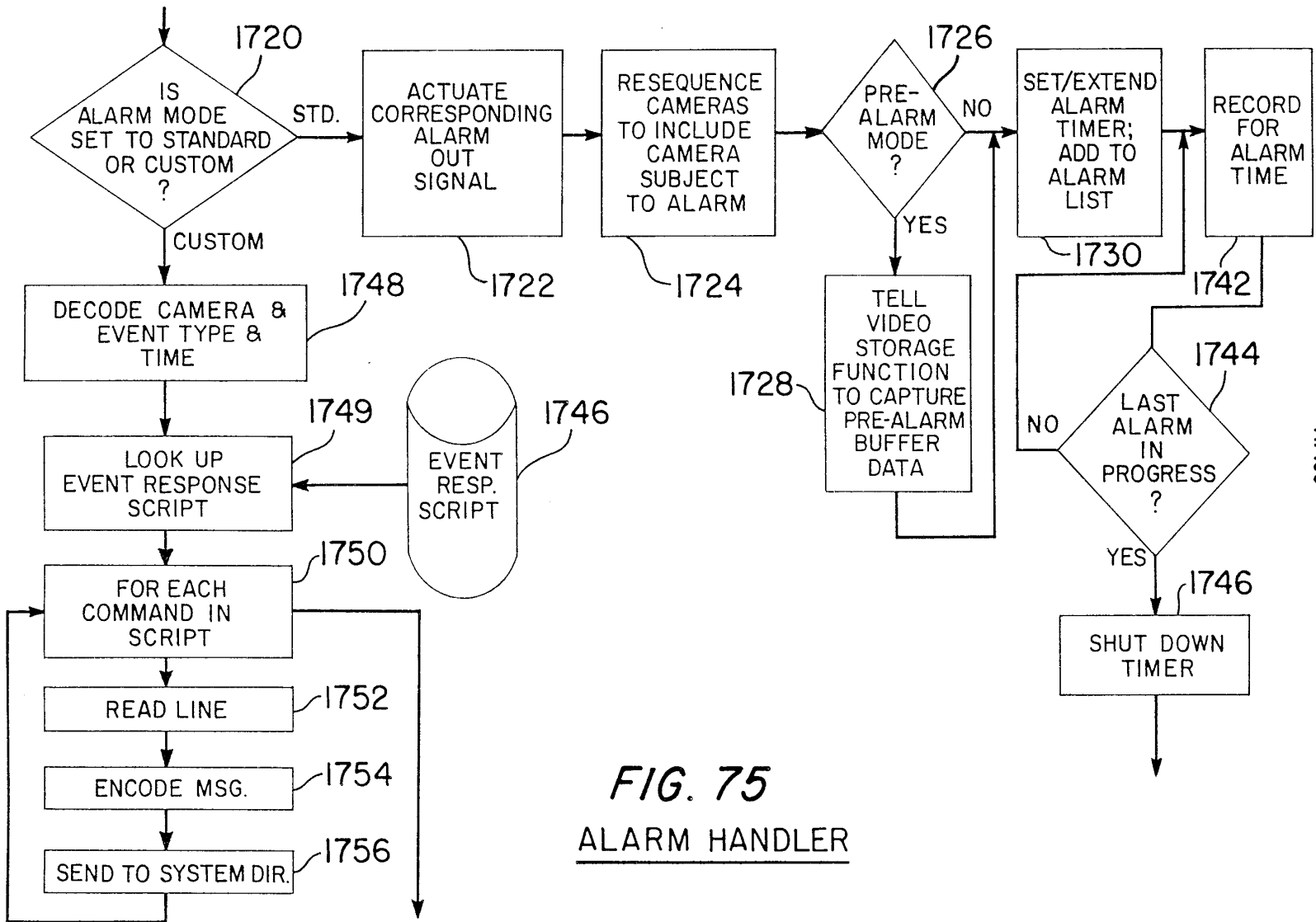
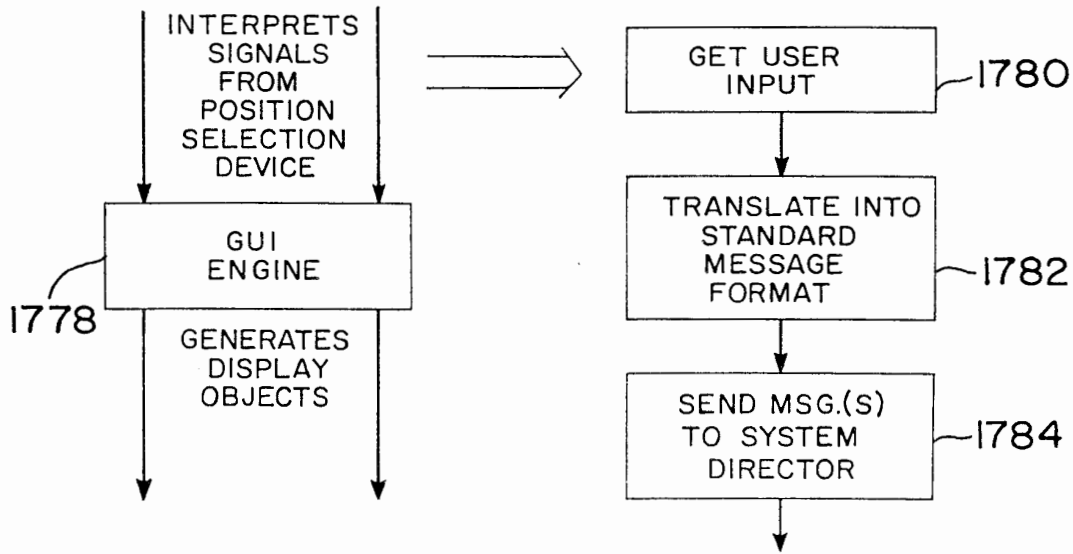


FIG. 74B

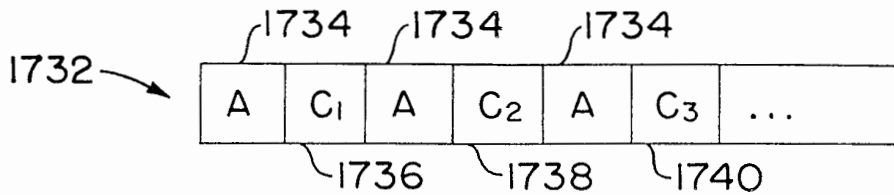


**FIG. 75**  
ALARM HANDLER

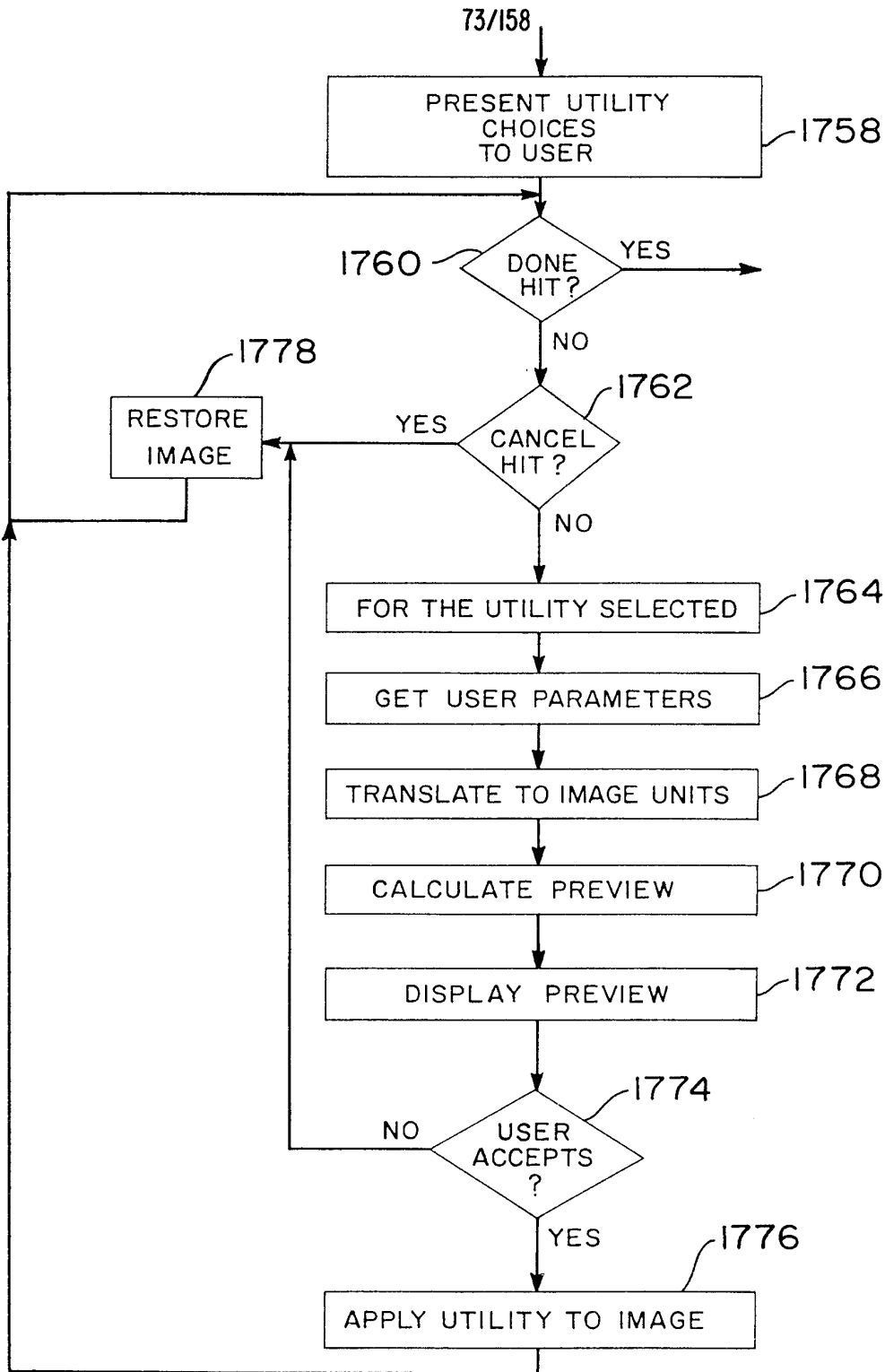
72/158



**FIG. 78**  
USER INTERFACE



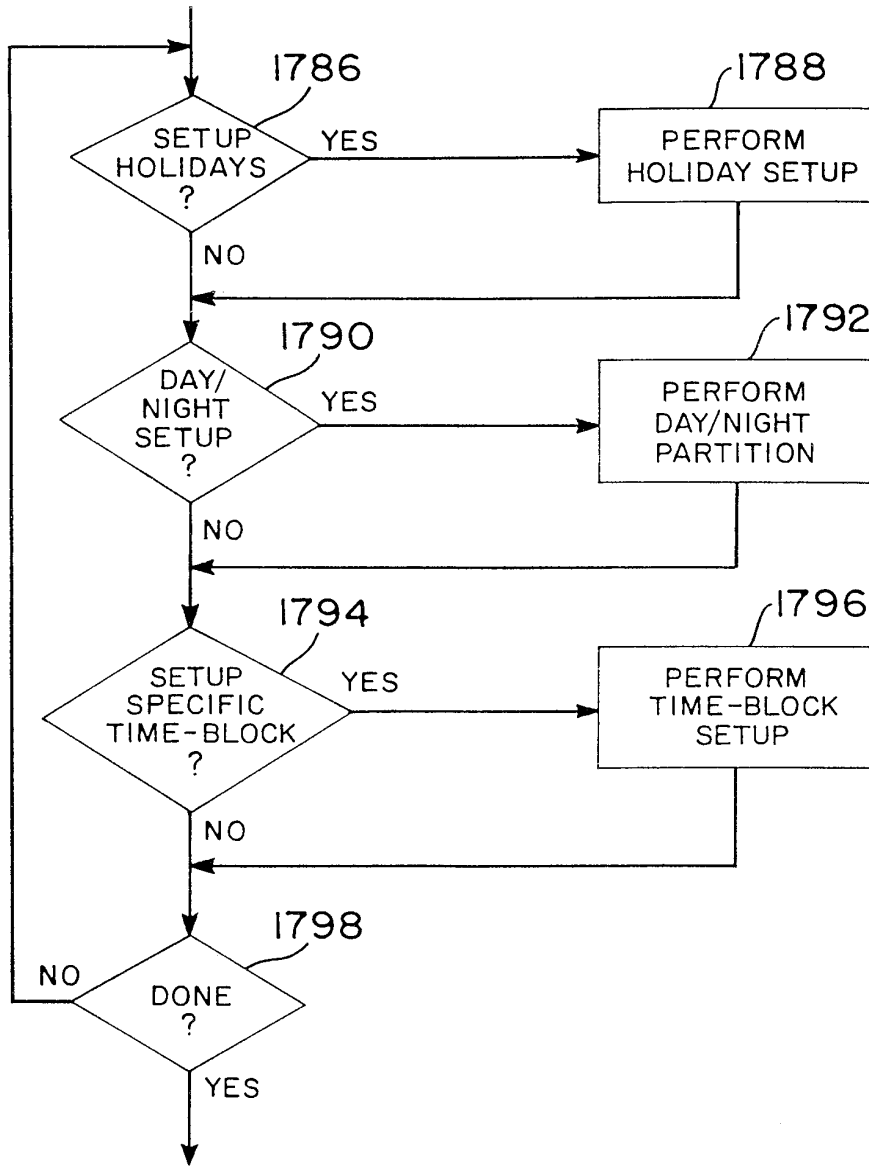
**FIG. 76**  
STANDARD FIELD  
RECORDING SEQUENCE FOR ALARM  
CONDITION



**FIG. 77**

IMAGE PROCESSING UTILITIES MGR.

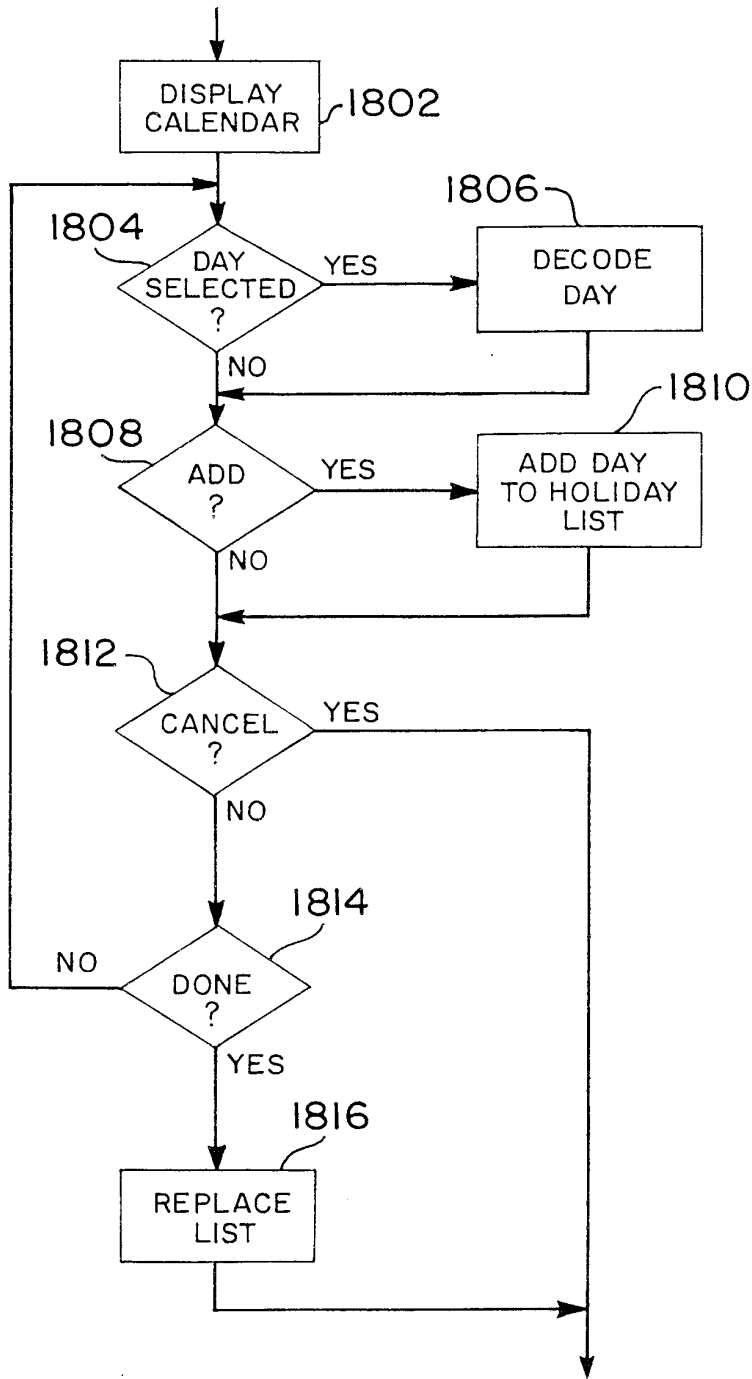
74/158



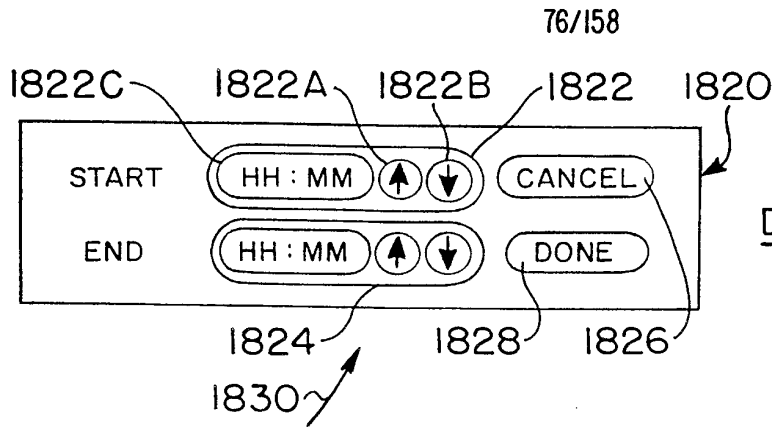
**FIG. 79**

SCHEDULING: SETUP: MAIN OPTIONS

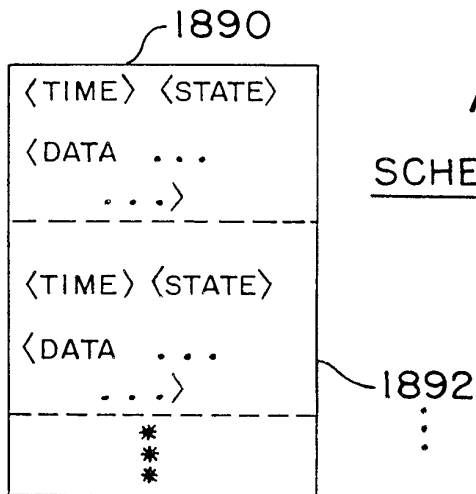
75/158



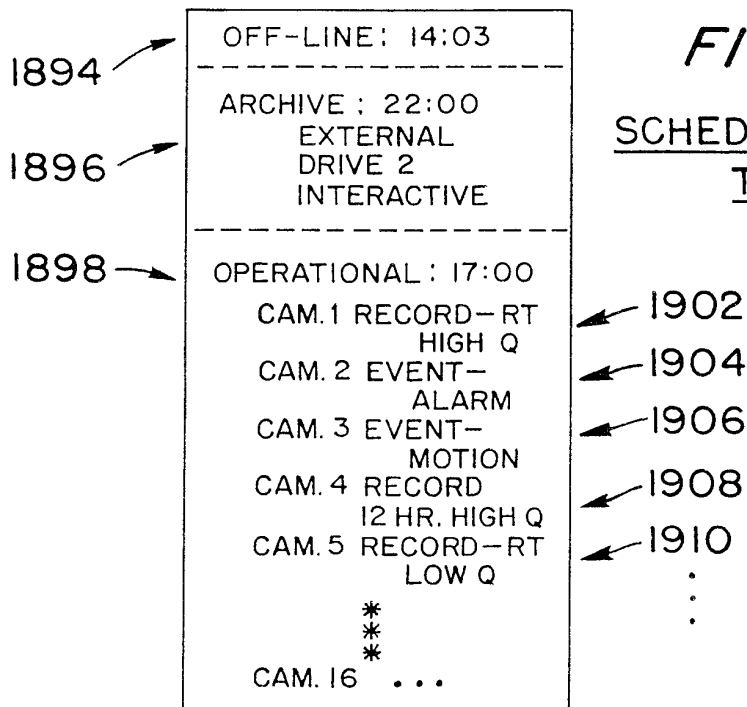
**FIG. 80**  
SCHEDULING: HOLIDAY SETUP



**FIG. 81**  
DAY/NIGHT PARTITION



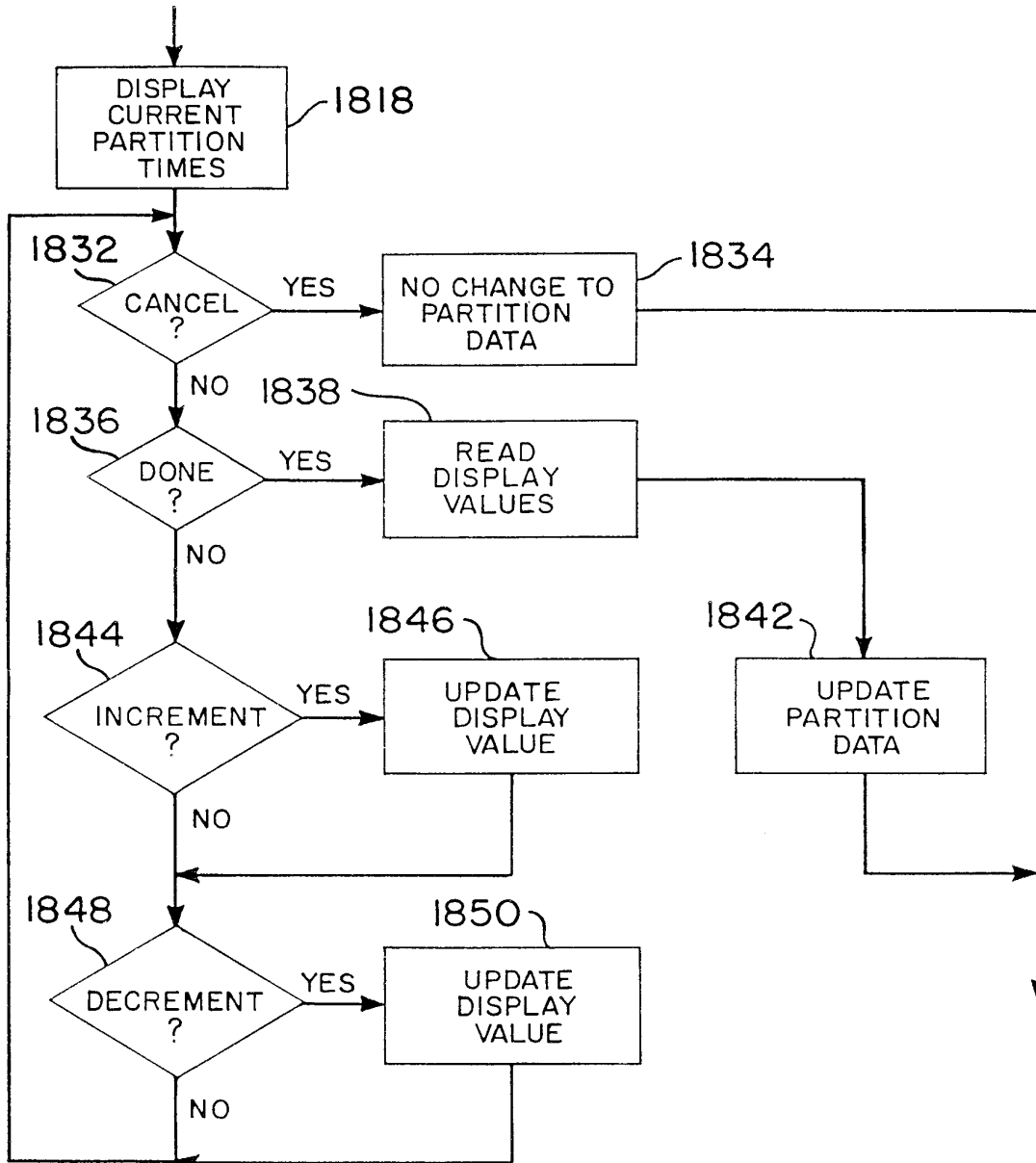
**FIG. 85**  
SCHEDULE QUEUE



**FIG. 86**  
SCHEDULE SCRIPT/TABLE



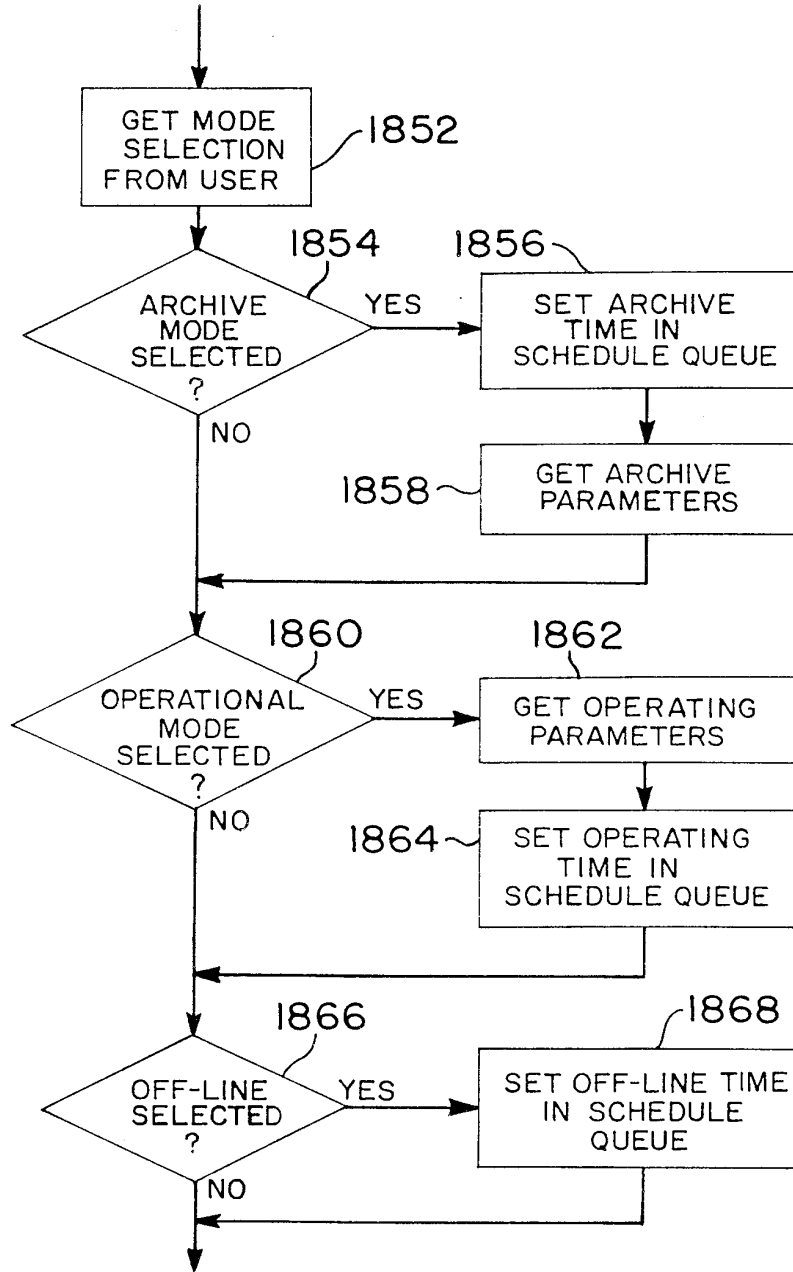
77/158



**FIG. 82**

DAY/NIGHT PARTITION

78/158



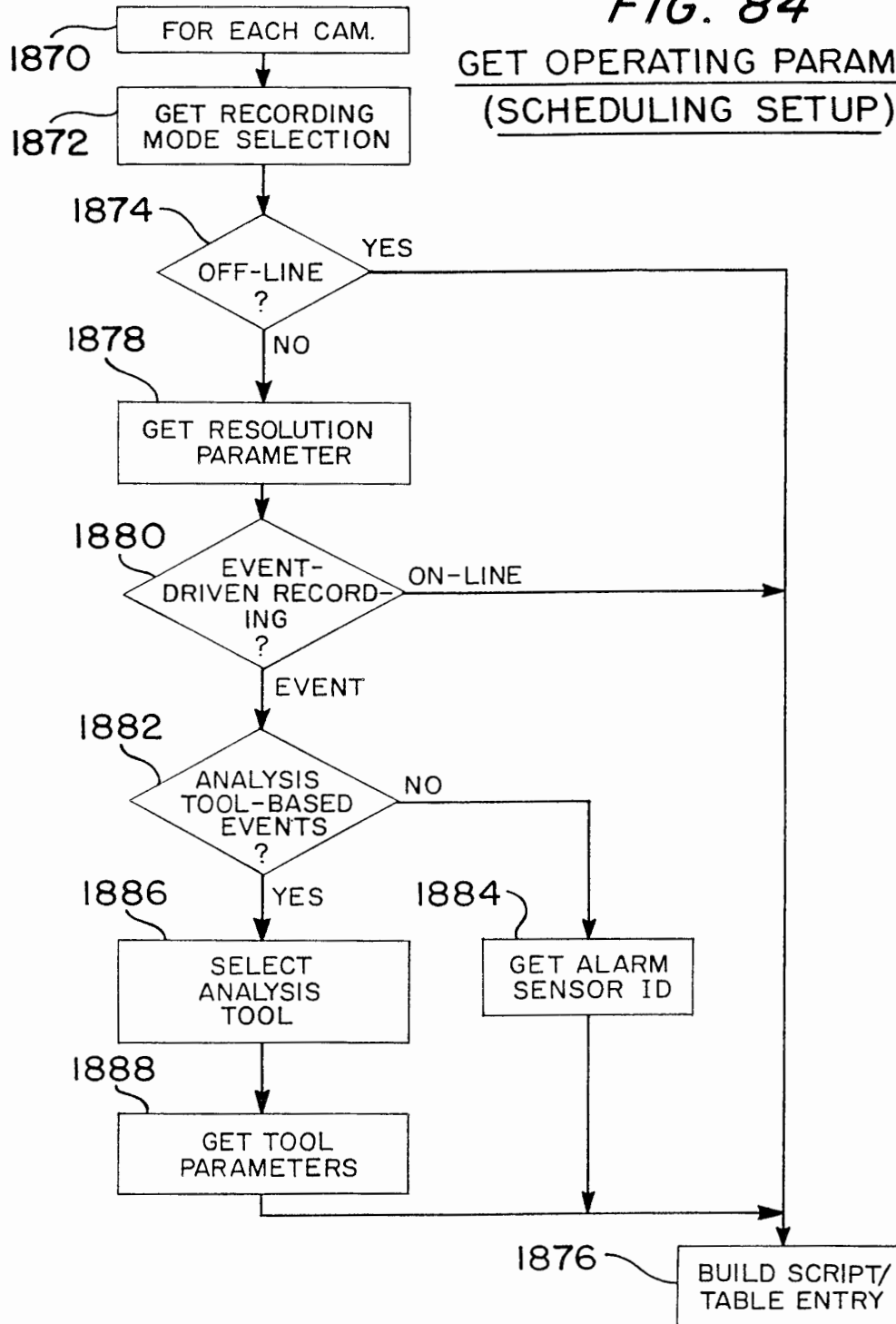
**FIG. 83**

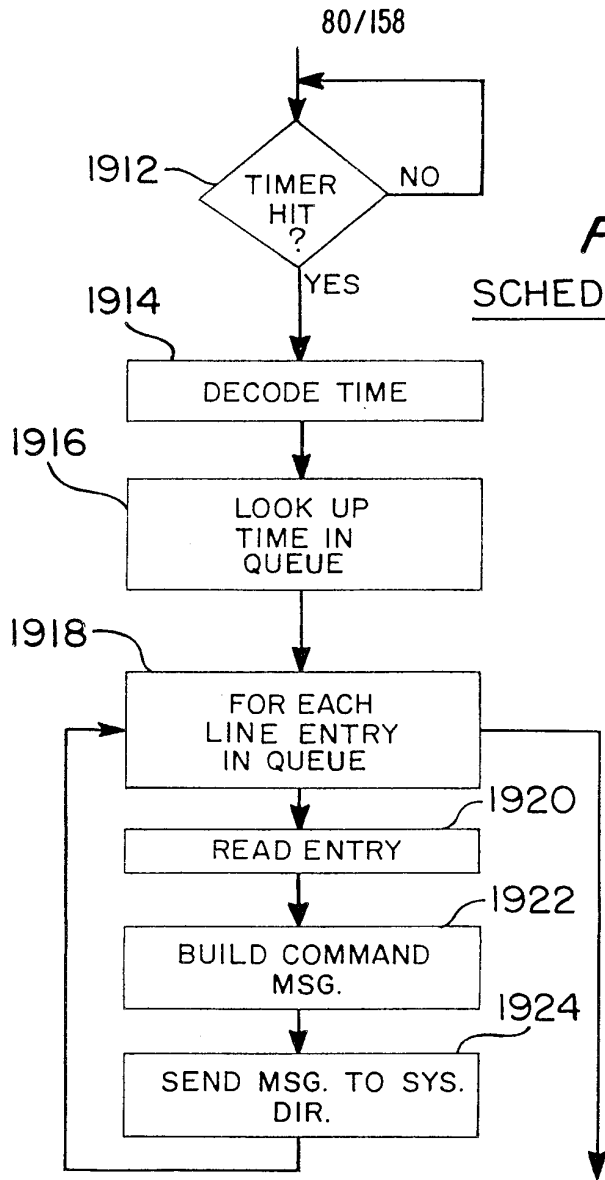
SCHEDULING SETUP: OPTION SELECTION

79/158

**FIG. 84**

GET OPERATING PARAMETERS  
(SCHEDULING SETUP)



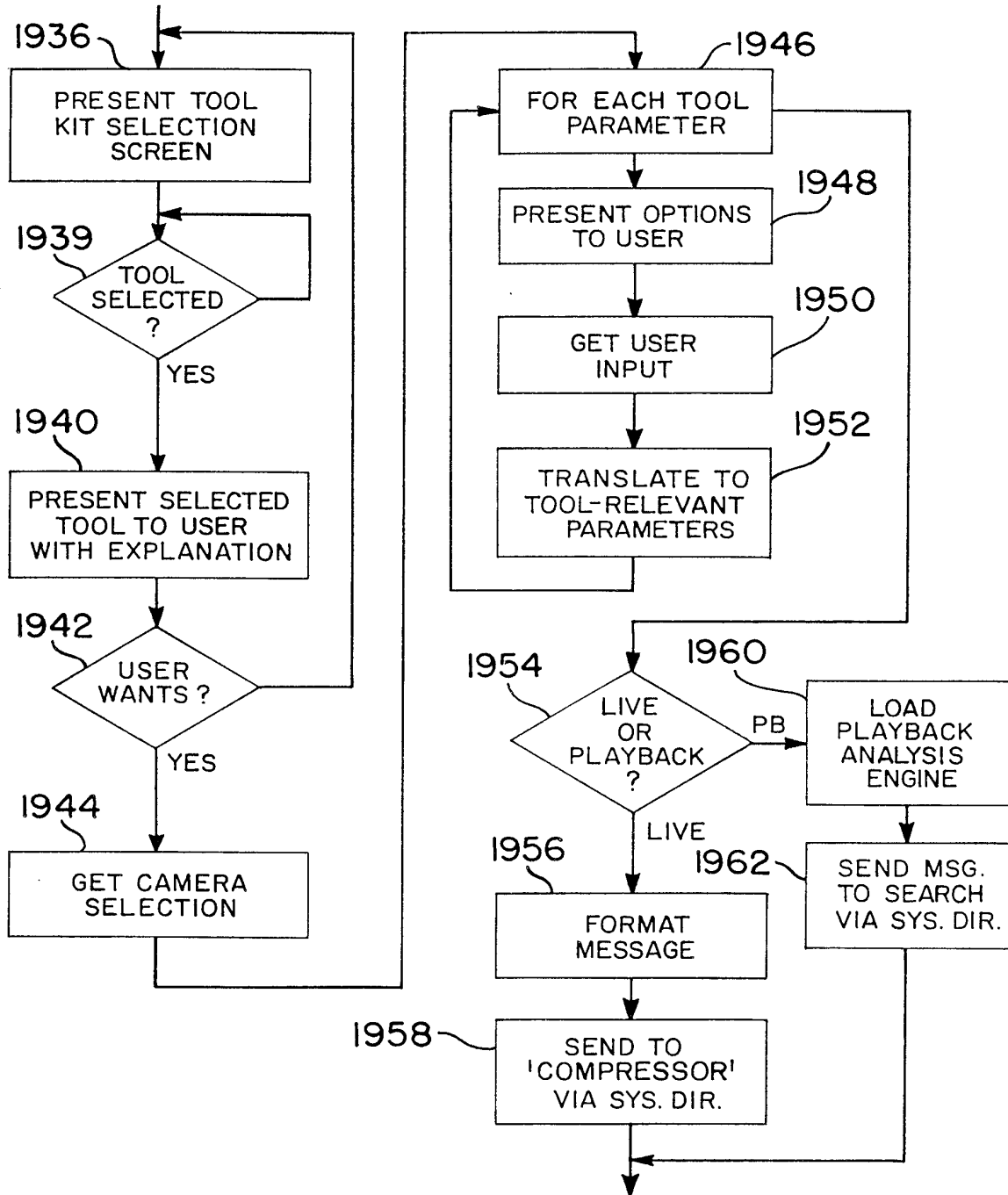


**FIG. 87**  
SCHEDULE EXECUTION

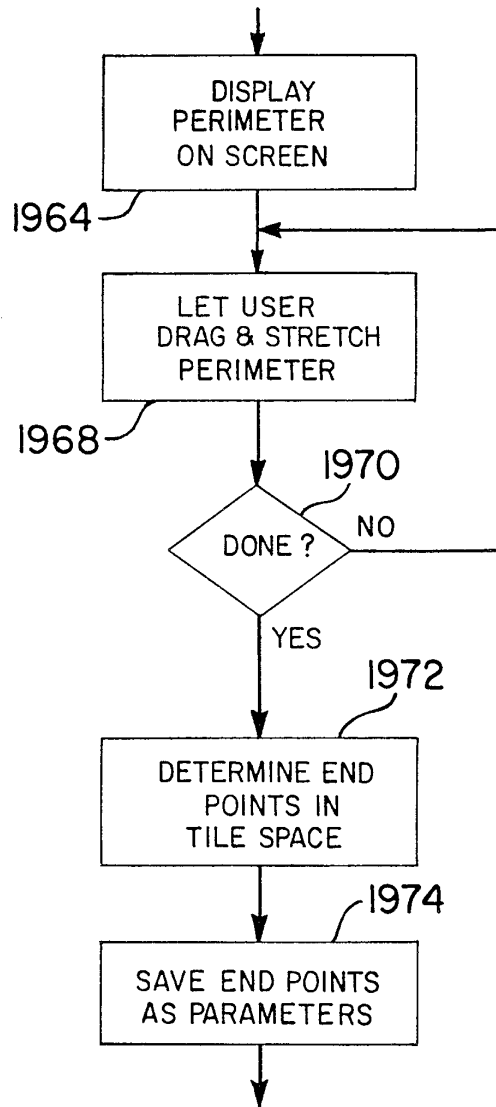
**FIG. 88**  
IMAGE ANALYSIS TOOLS-OVERVIEW

1926		1932		1934
USER I/F		EXECUTION		RESULTS / CONSEQUENCES
1928	SELECT TOOL	SETUP TOOL	- LIVE - PLAYBACK	
1930				

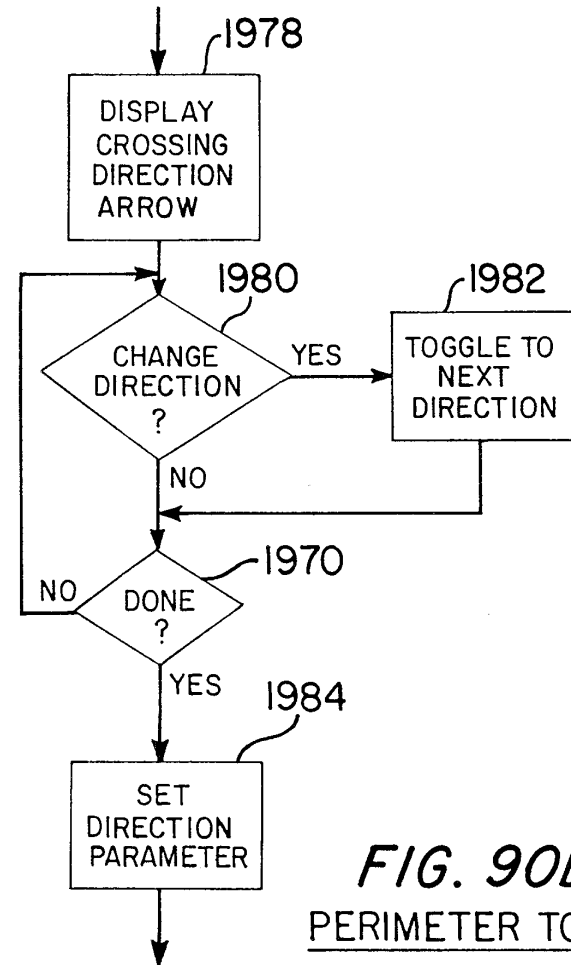
81/158



**FIG. 89**  
SELECT & SETUP ANALYSIS TOOL



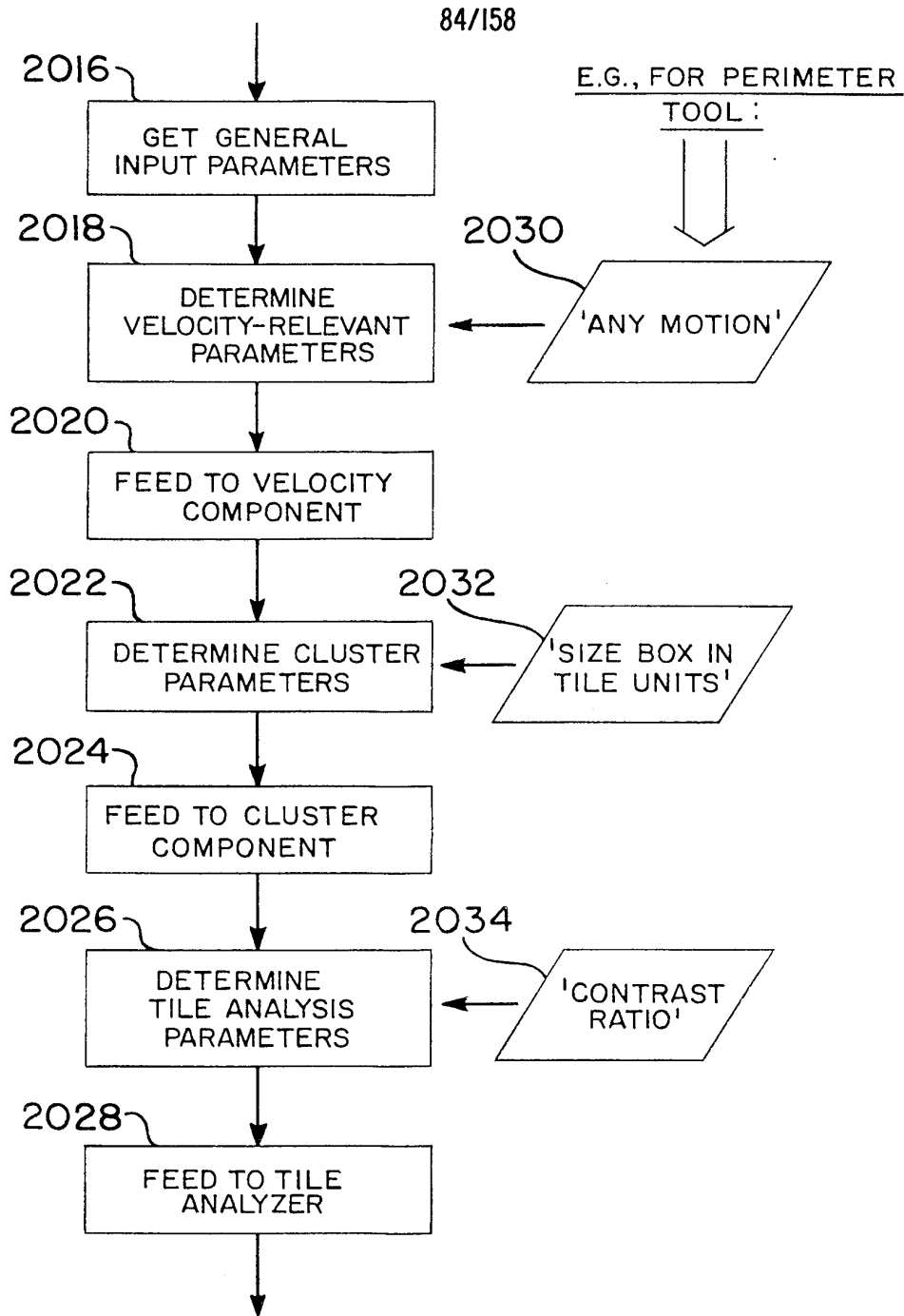
**FIG. 90A**  
PERIMETER TOOL:  
PARAMETER SETTING:  
PERIMETER SIZE  
& LOCATION



**FIG. 90B**  
PERIMETER TOOL:  
PARAMETER SETTING:  
CROSSING DIRECTION

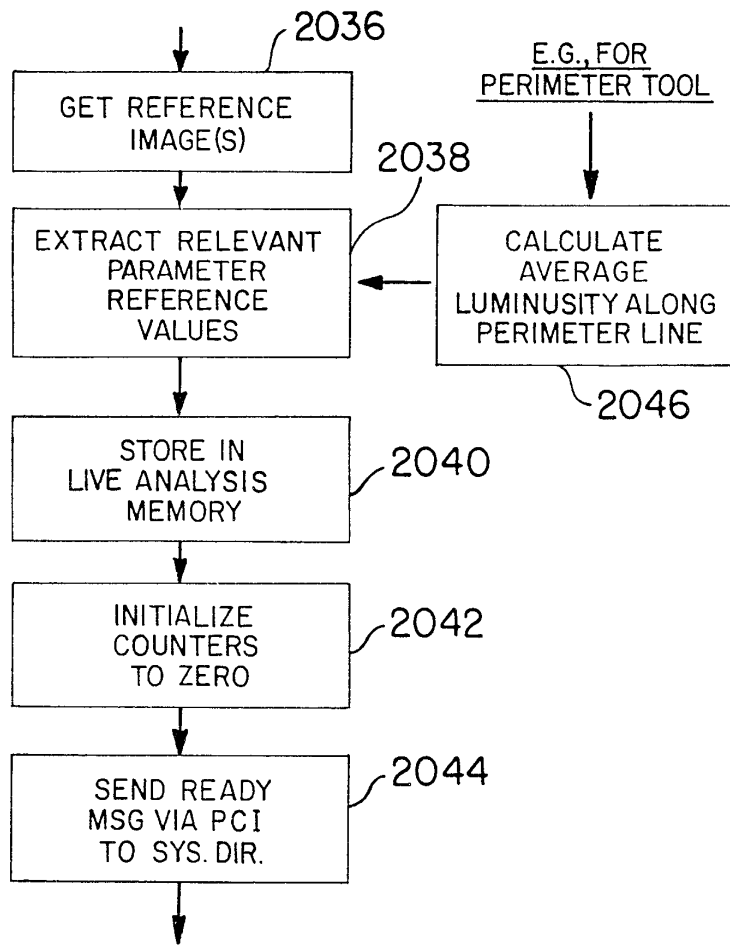
[REDACTED]

[REDACTED]

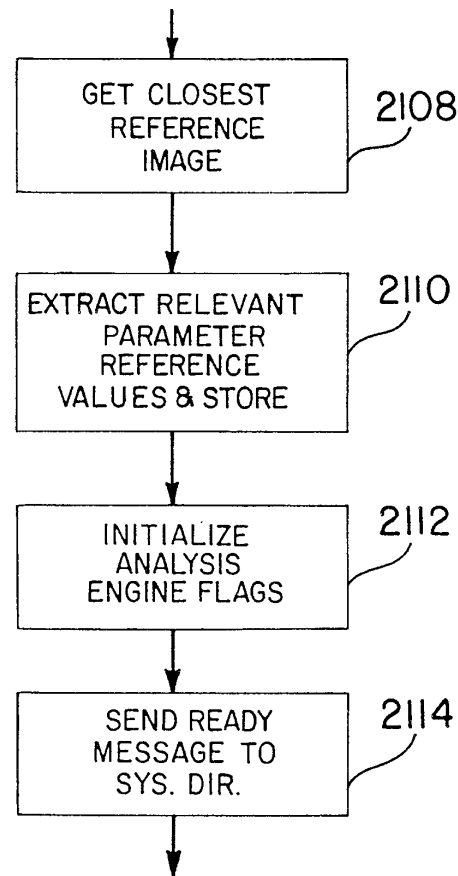


**FIG. 91**  
LOADING ANALYSIS ENGINE

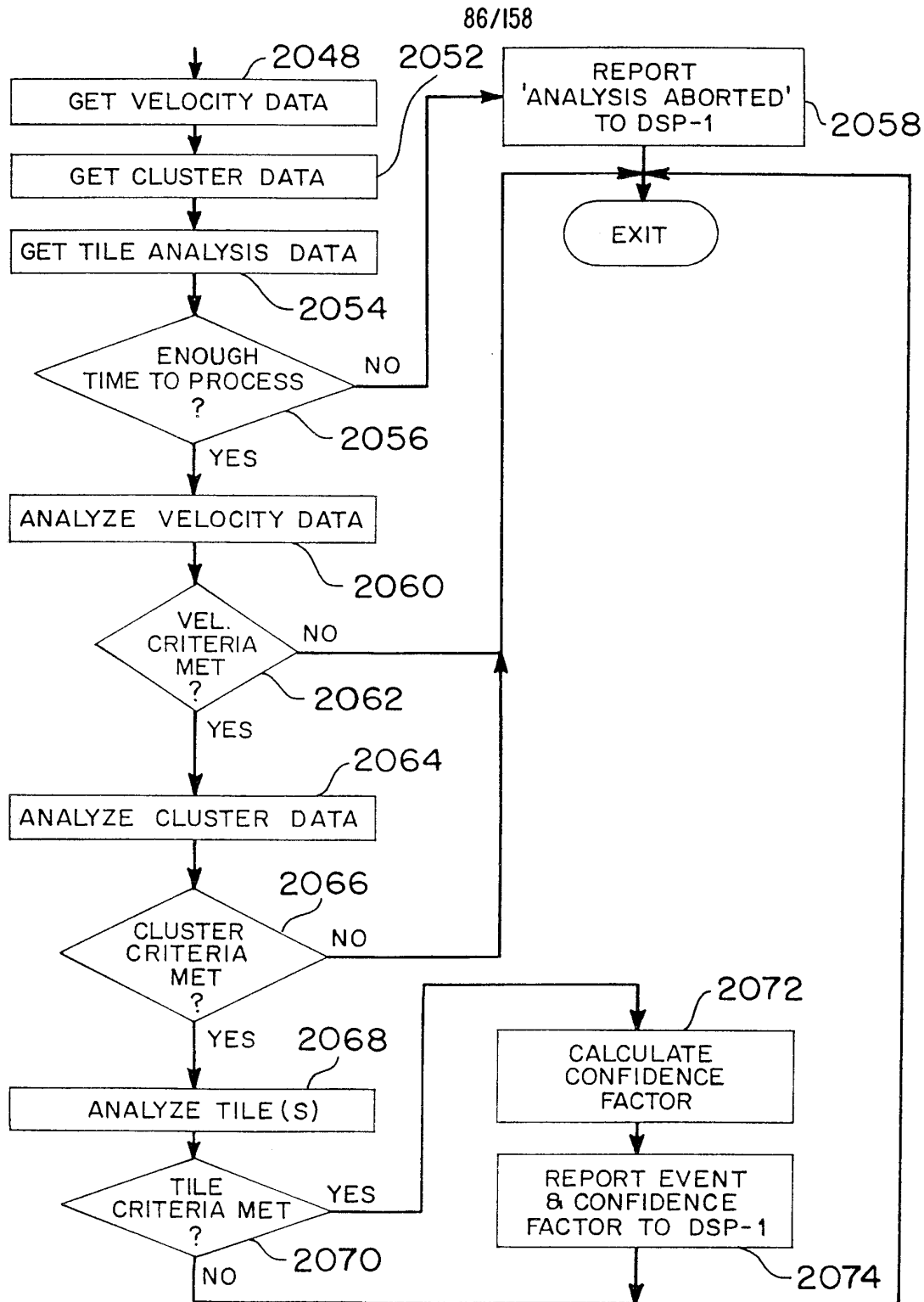




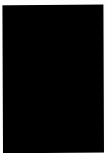
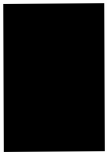
**FIG. 92**  
INITIALIZE LIVE ANALYSIS

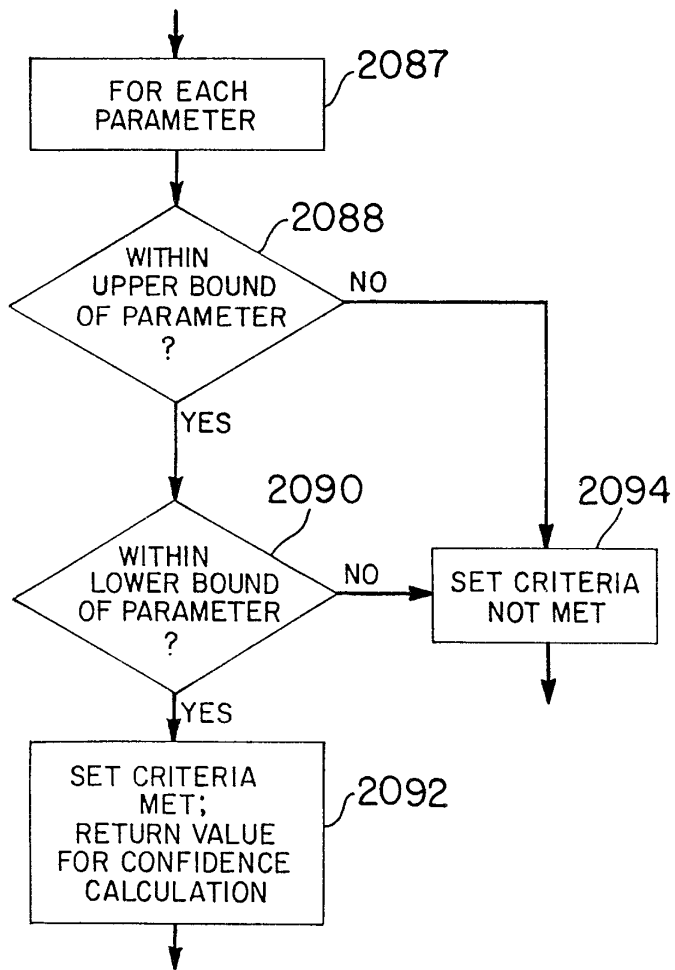


**FIG. 94**  
INITIALIZE  
SEARCH ANALYSIS

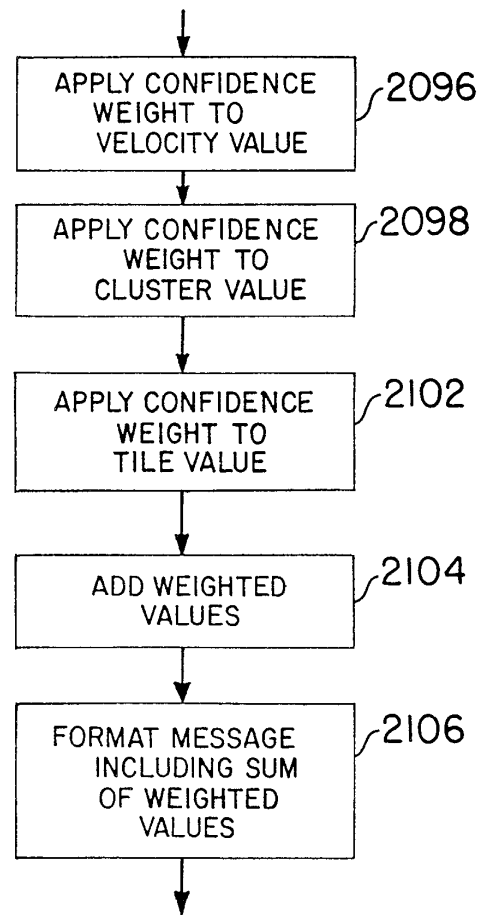


**FIG. 93A**  
**LIVE ANALYSIS OPERATION (PERIMETER TOOL)**

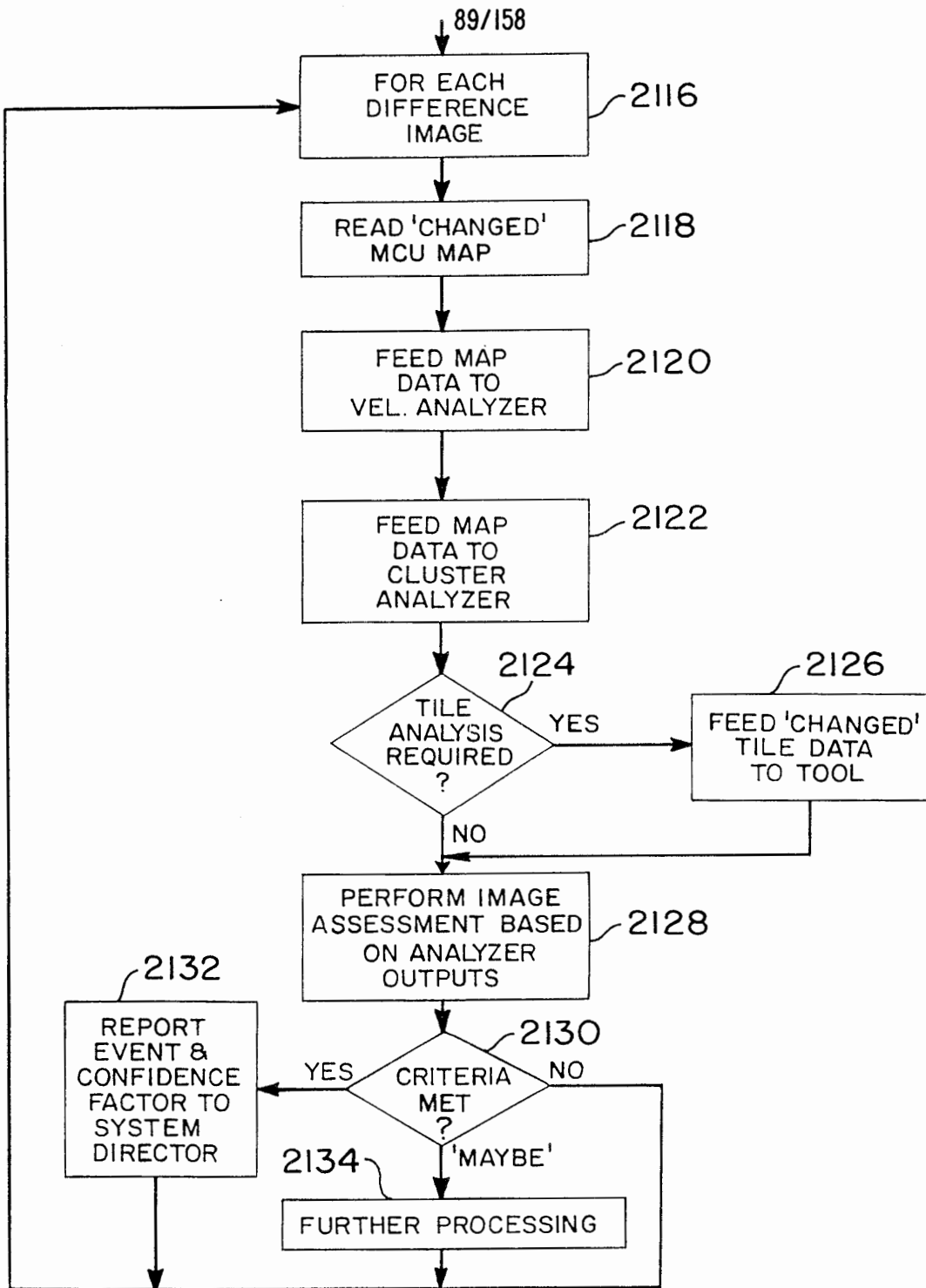




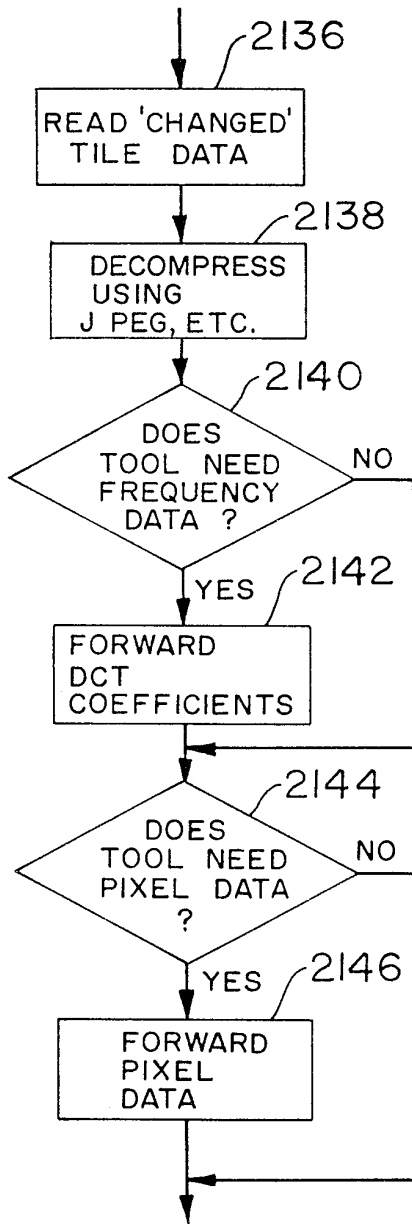
**FIG. 93D**  
CRITERIA MET?



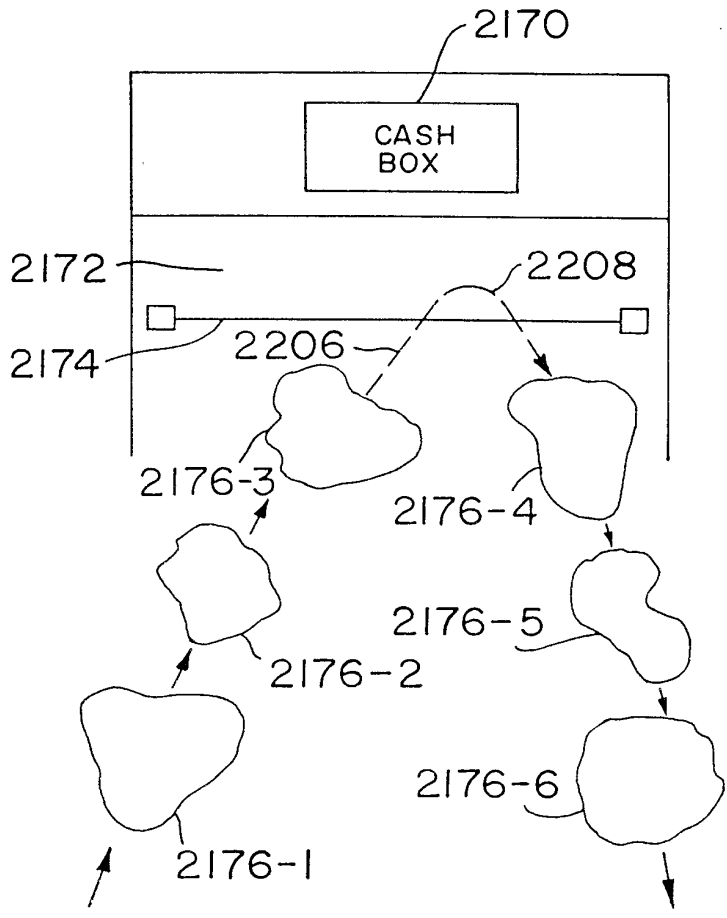
**FIG. 93E**  
CONFIDENCE FACTOR  
CALCULATION



**FIG. 95A**  
PLAYBACK ANALYSIS OPERATION

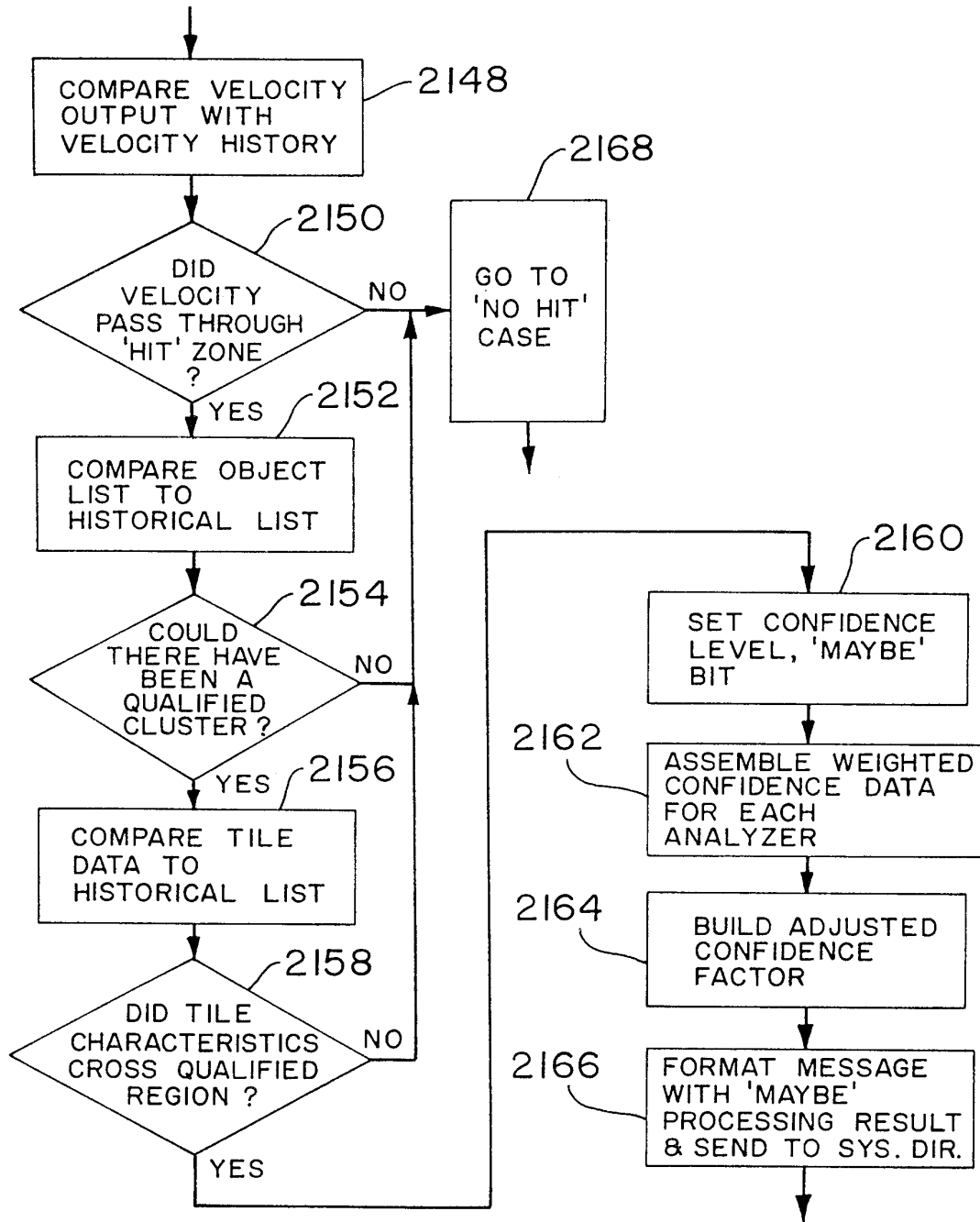


**FIG. 95B**  
FEED 'CHANGED'  
TILE DATA

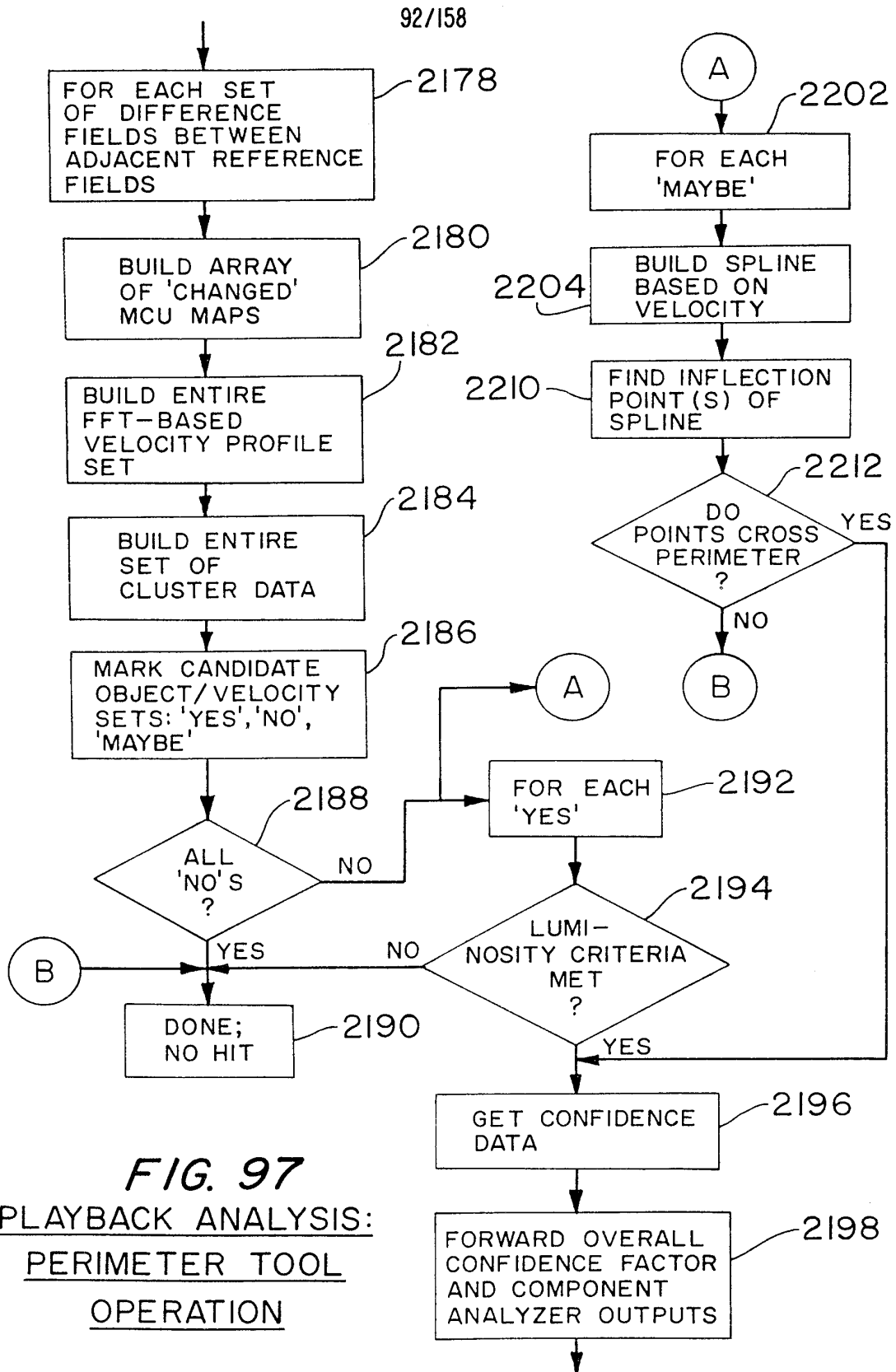


**FIG. 96**  
PLAYBACK ANALYSIS--  
CURVE-FITTING EXAMPLE

9/158

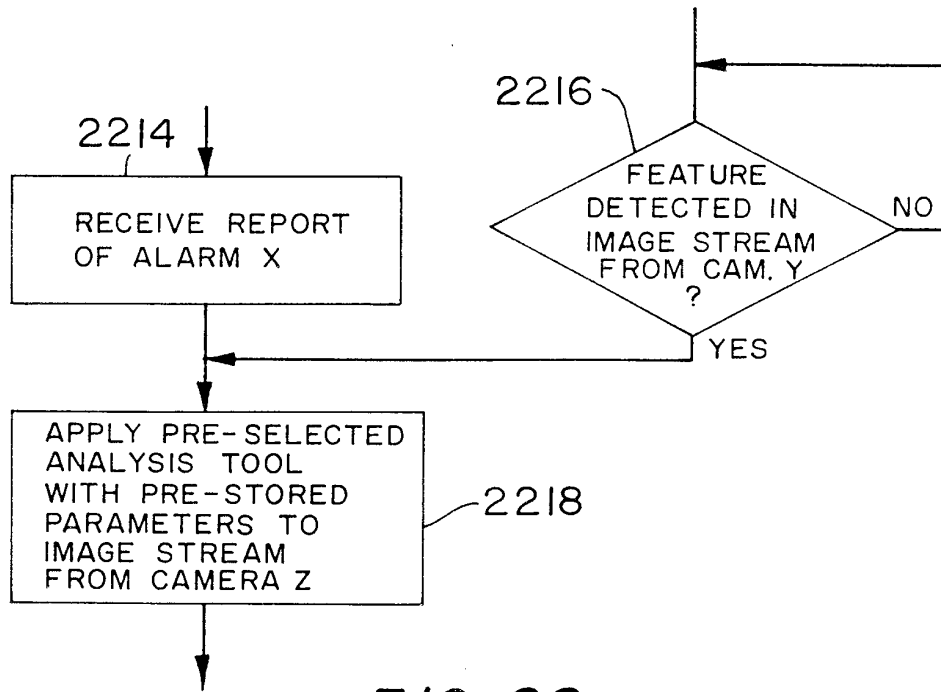


**FIG. 95C**  
PROCESSING  
THE 'MAYBE' CASE





93/158

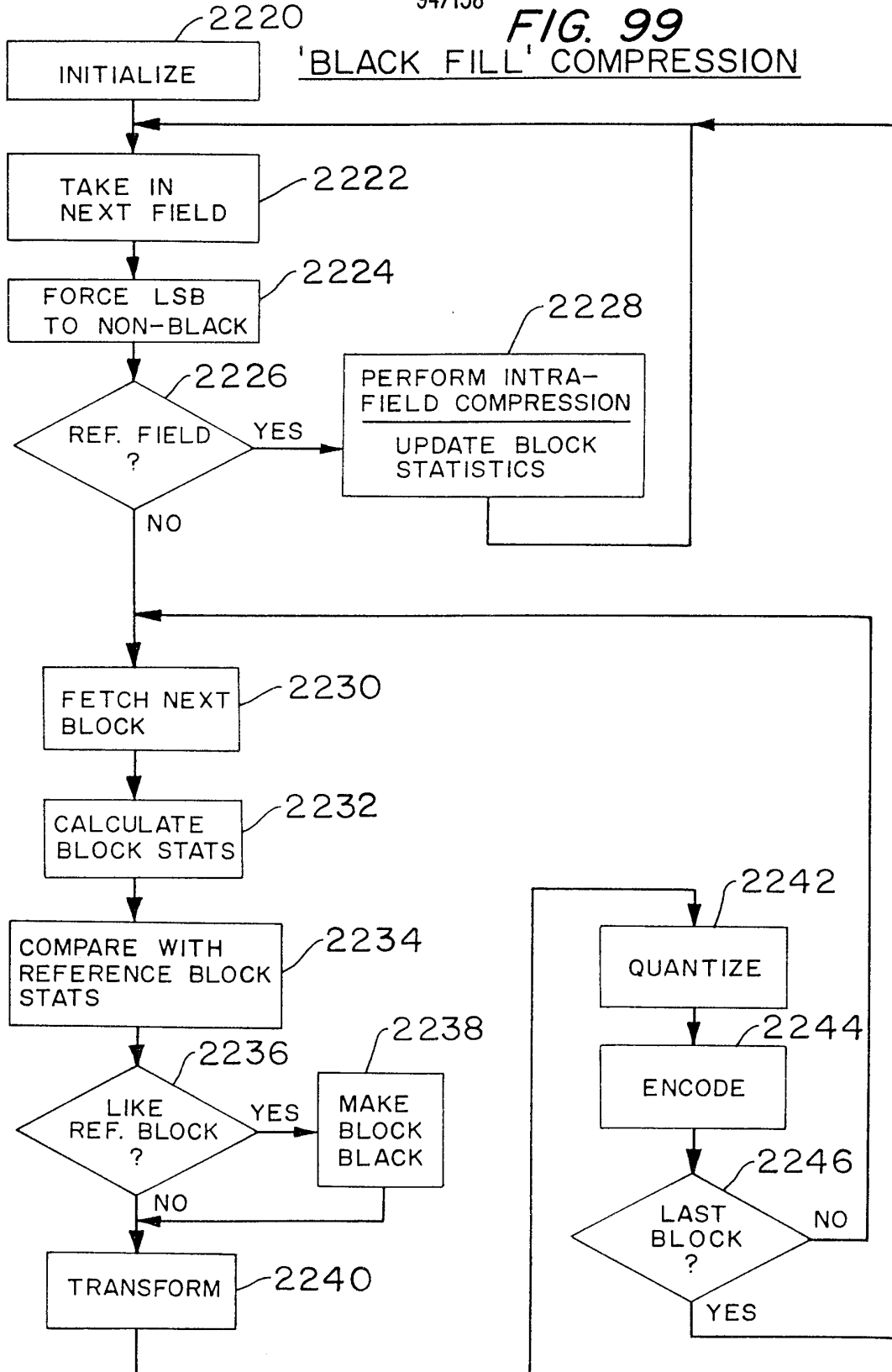


**FIG. 98**  
EVENT-ACTUATED  
LIVE ANALYSIS TOOL

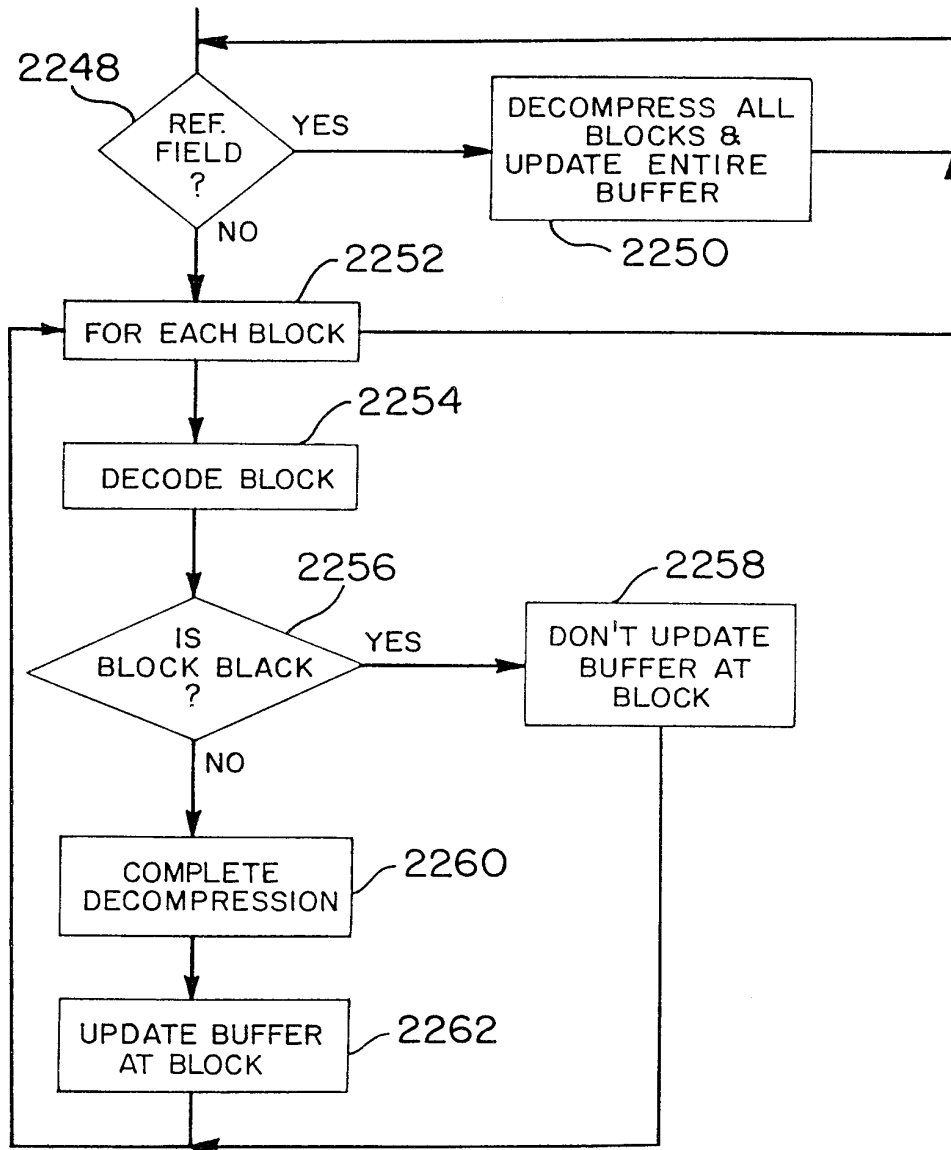
94/158

FIG. 99

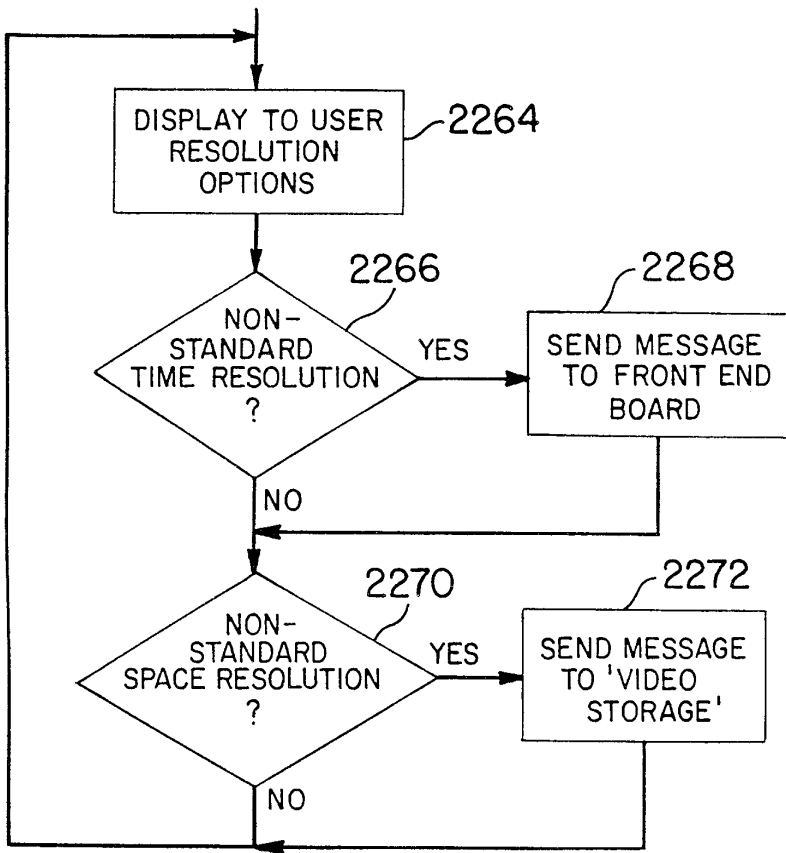
'BLACK FILL' COMPRESSION



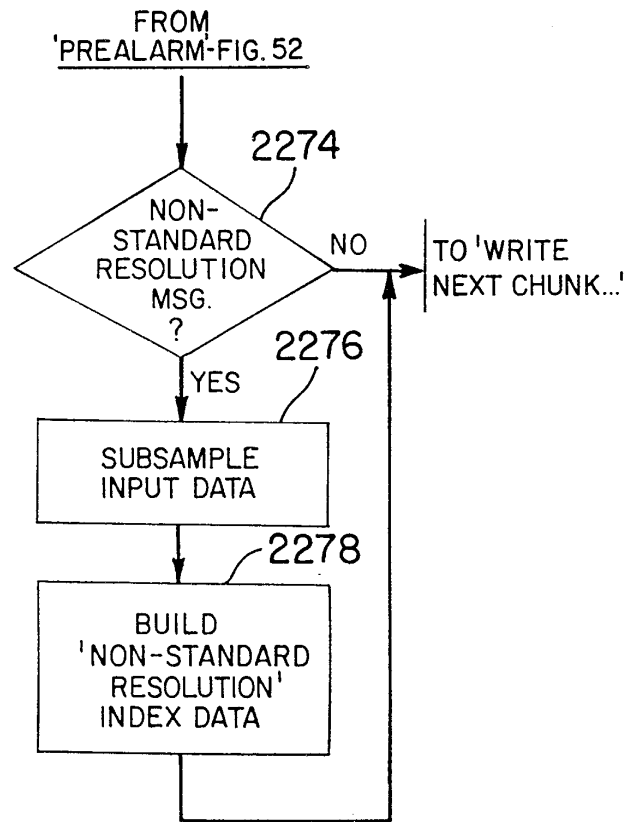
95/158



**FIG. 100**  
'BLACK FILL' DECOMPRESSION

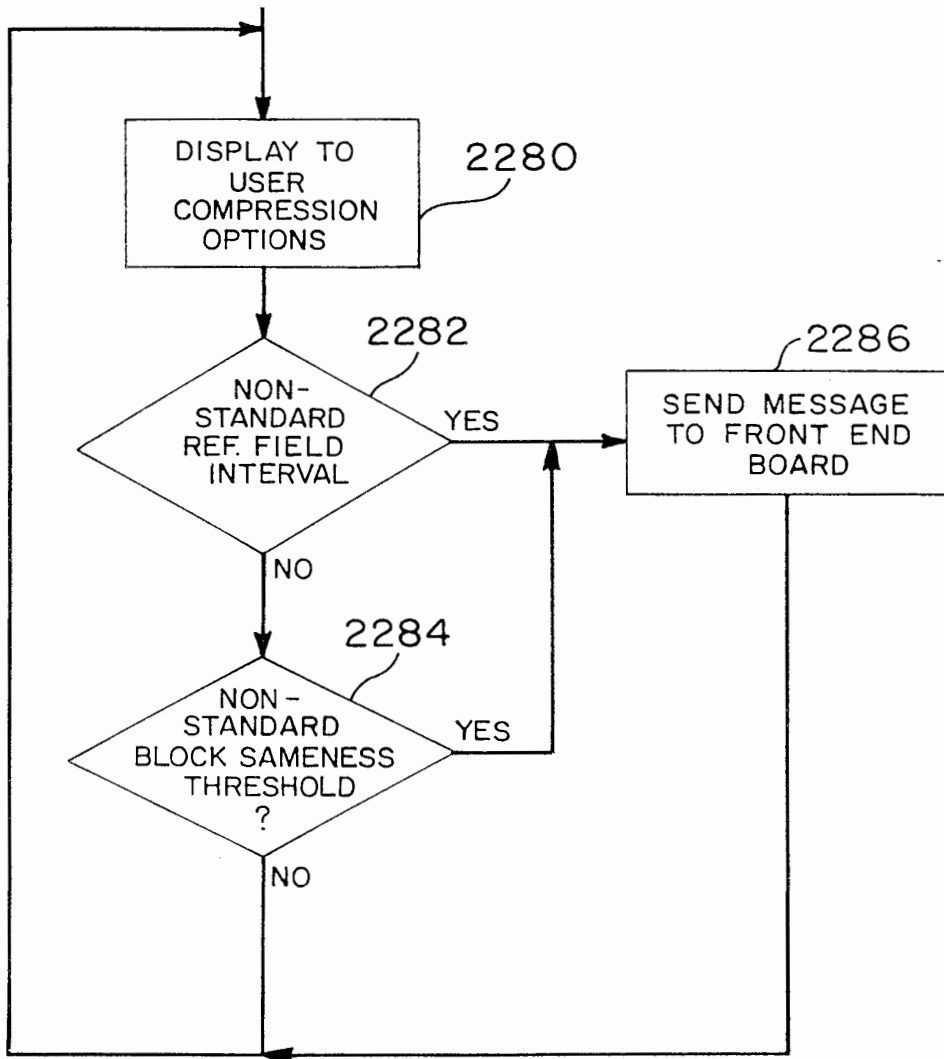


**FIG. 10IA**  
VIDEO RESOLUTION – SETUP



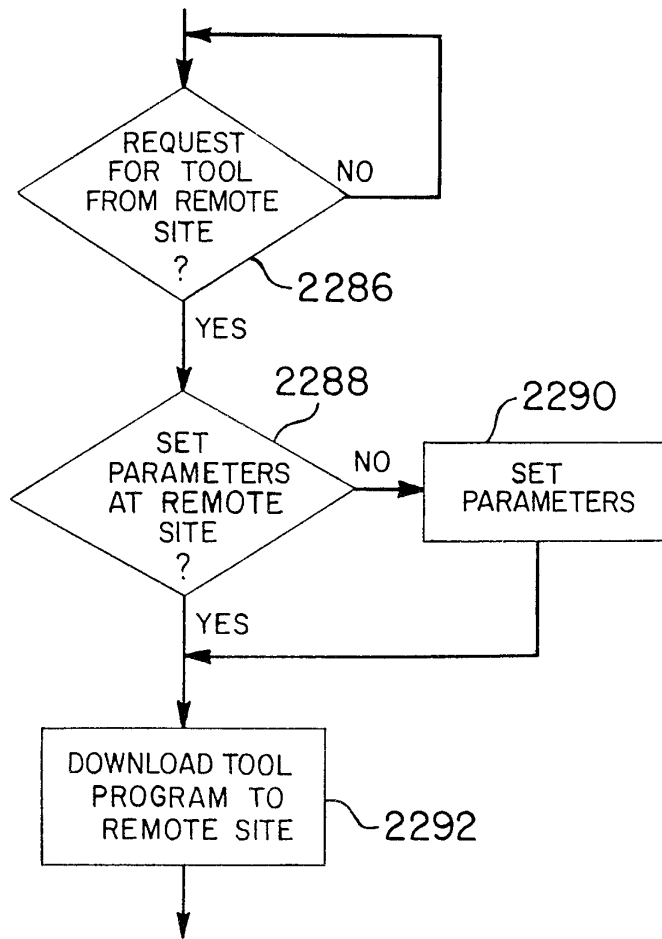
**FIG. 10IB**  
VIDEO RESOLUTION – OPERATION

97/158

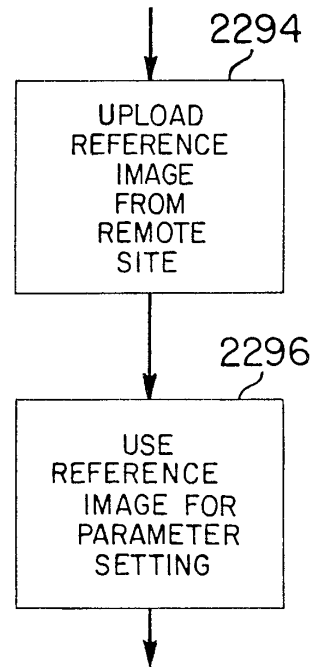


**FIG. 102**

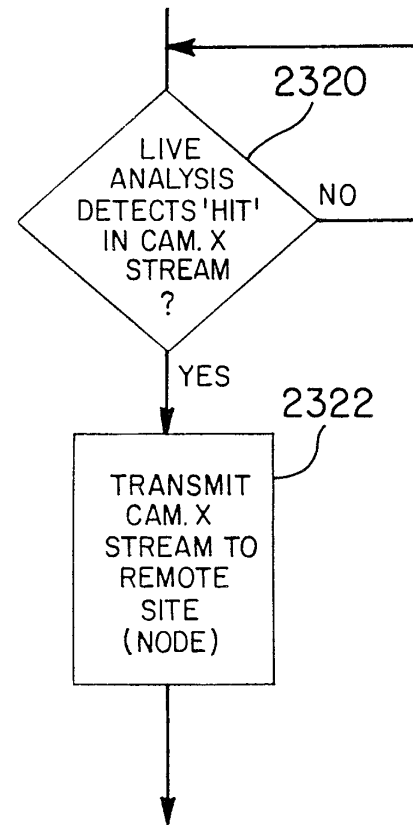
SETTING COMPRESSION PARAMETERS



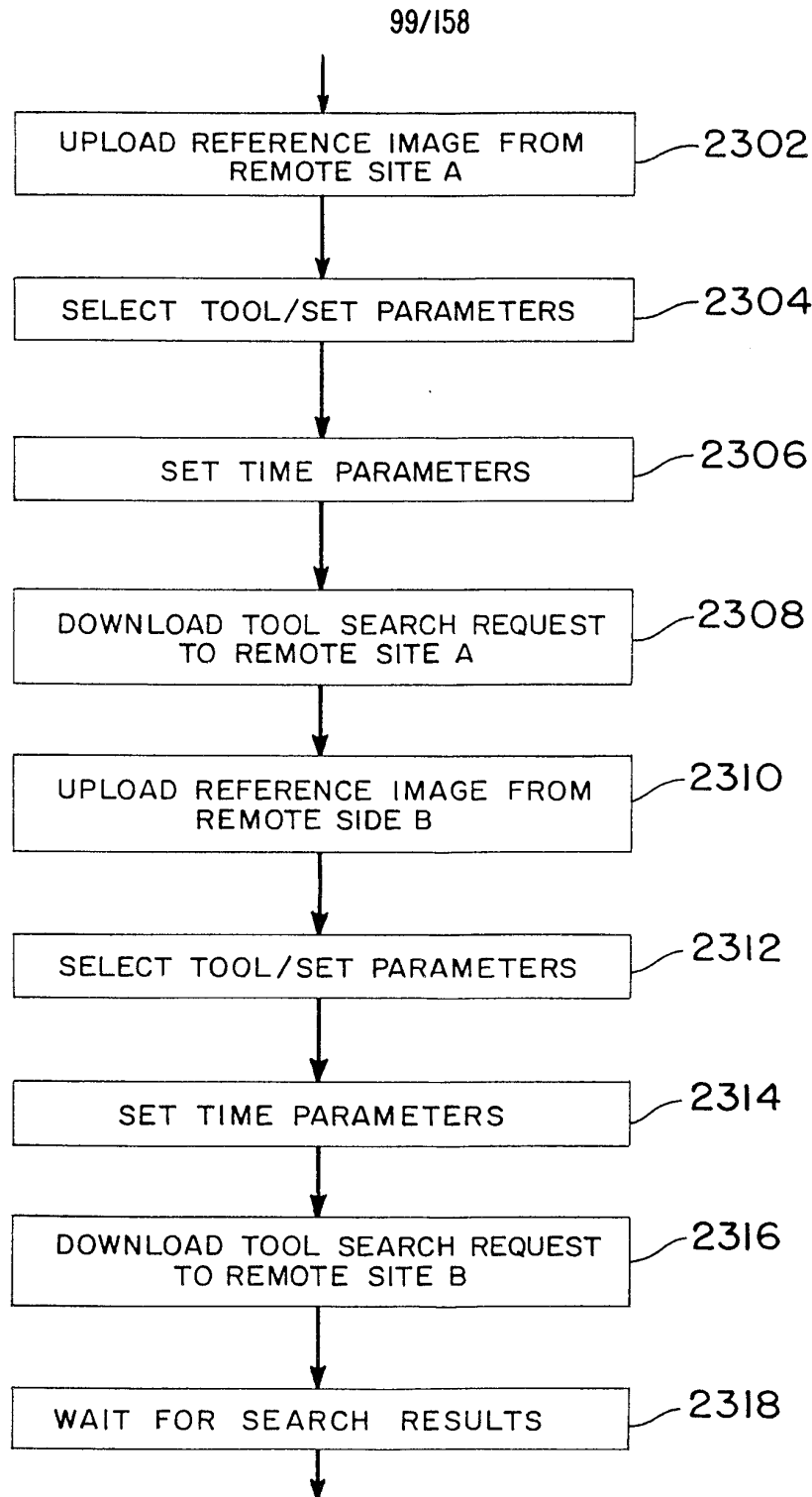
**FIG. 103A**  
DOWNLOADING SEARCH TOOLS ON REQUEST



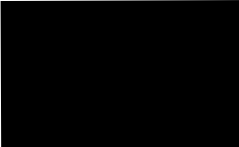
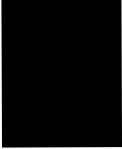
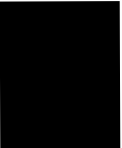
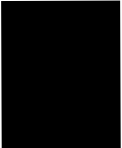
**FIG. 103B**  
DOWNLOADING SEARCH TOOLS: 'SET PARAMETERS'



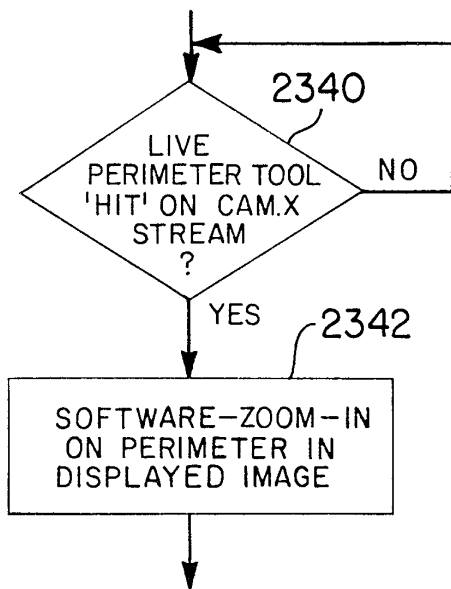
**FIG. 104**  
SOFT-ALARM-ACTUATED STORAGE



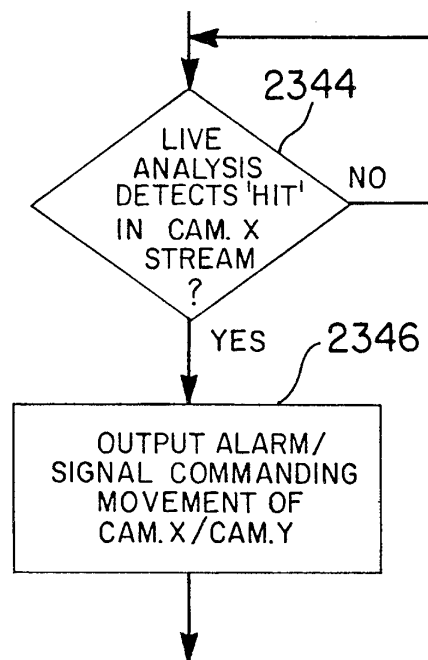
**FIG. 103C**  
DOWNLOADING SEARCH TOOLS TO MULTIPLE SITES



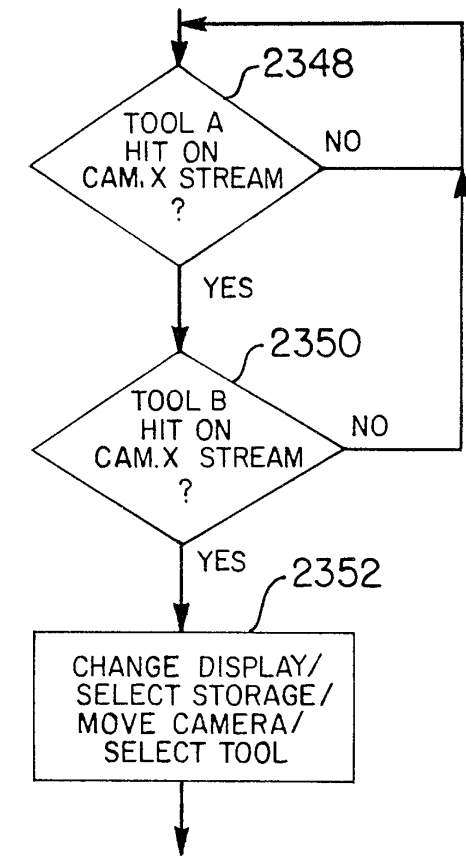




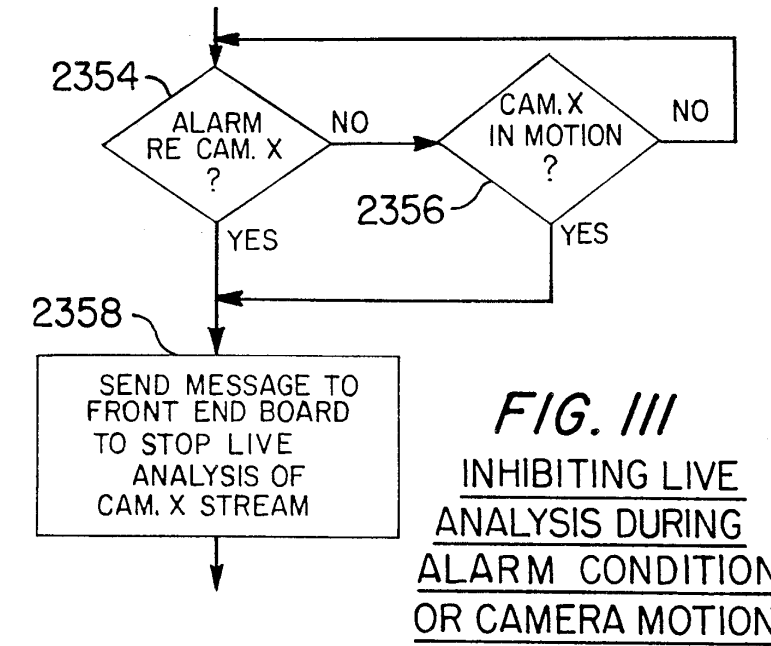
**FIG. 108**  
SOFT-ALARM-ACTUATED  
ZOOM-IN



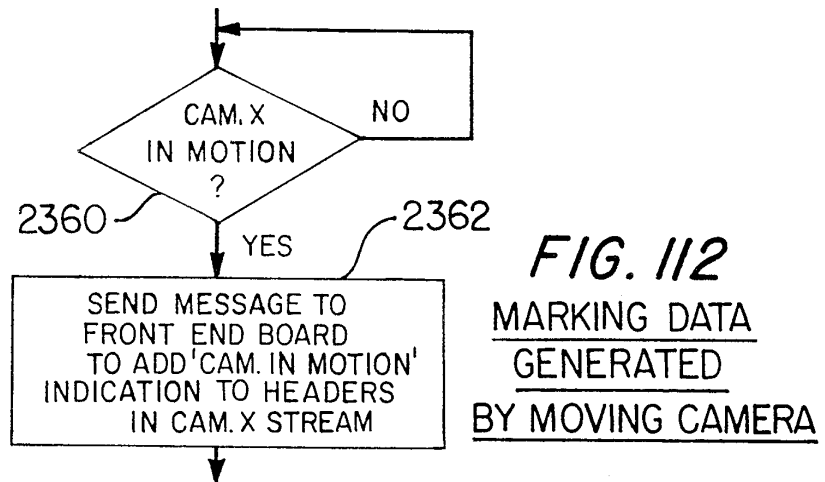
**FIG. 109**  
SOFT-ALARM-ACTUATED  
CAMERA TARGETING



**FIG. 110**  
SYSTEM RESPONSE  
TO HITS BY  
MULTIPLE TOOLS



**FIG. 111**  
INHIBITING LIVE  
ANALYSIS DURING  
ALARM CONDITION  
OR CAMERA MOTION



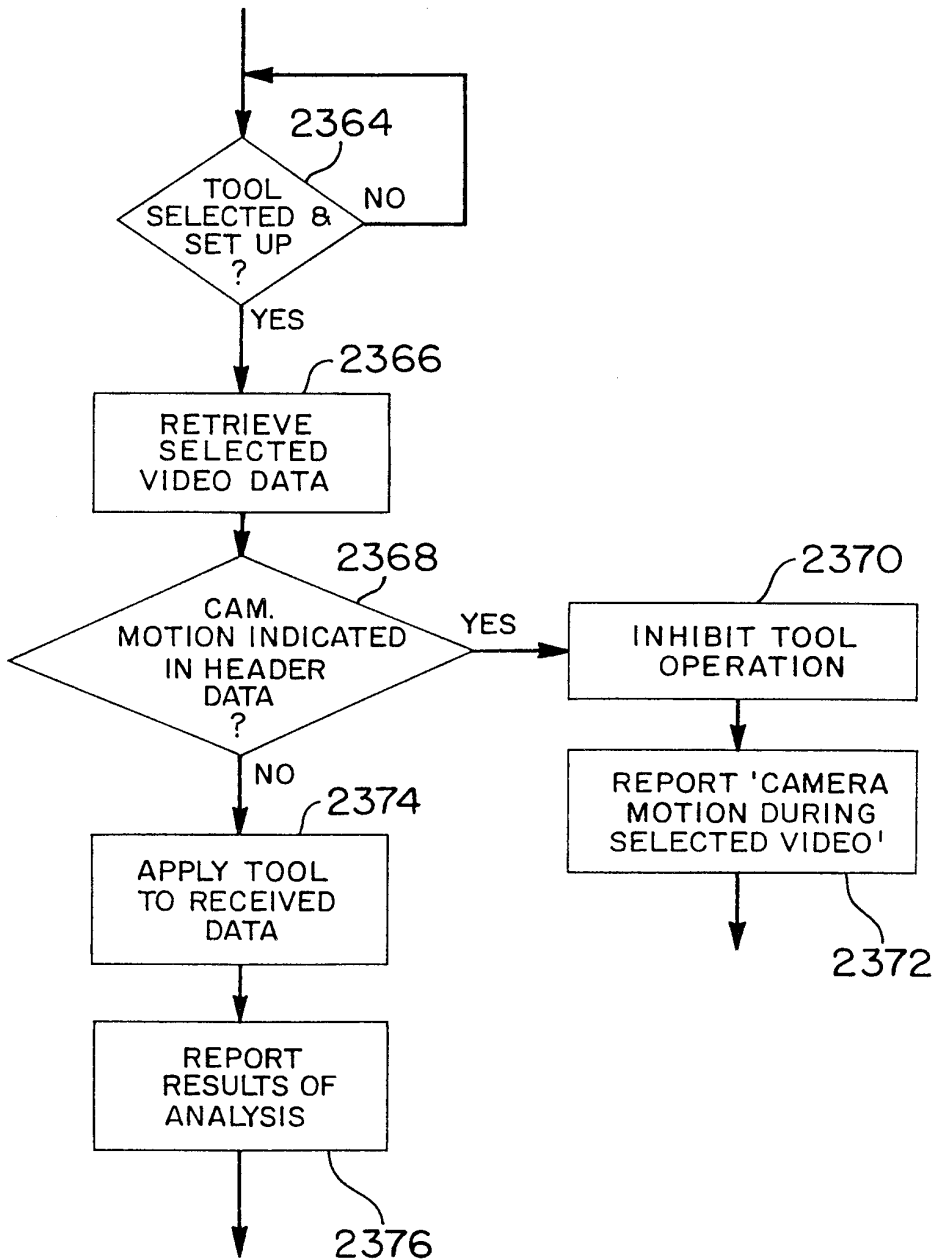
**FIG. 112**  
MARKING DATA  
GENERATED  
BY MOVING CAMERA

WO 98/19450

102/158

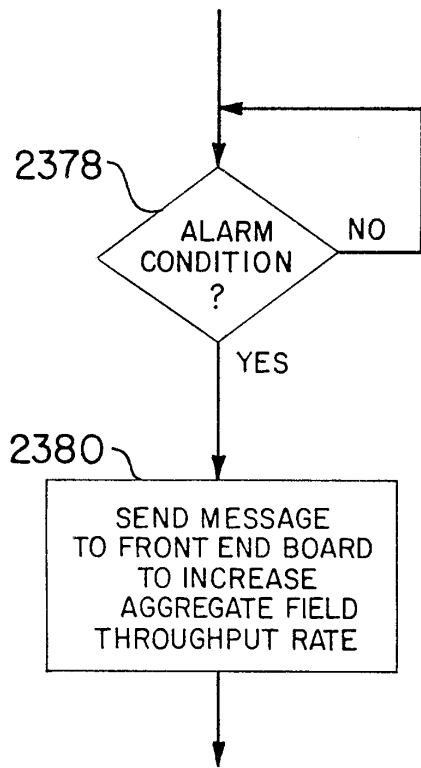
PCT/US97/17886

103/158



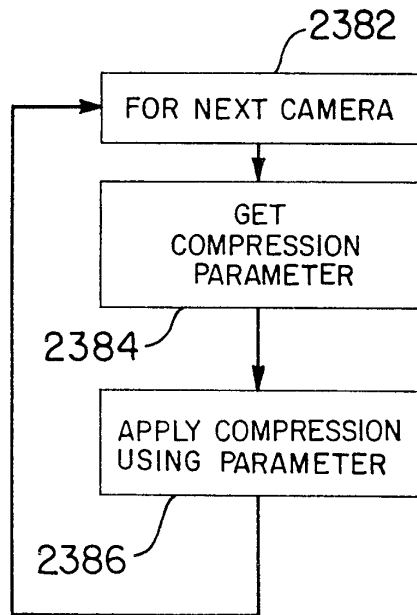
**FIG. 112A**

INHIBITING PLAYBACK ANALYSIS OF DATA GENERATED BY MOVING CAMERA



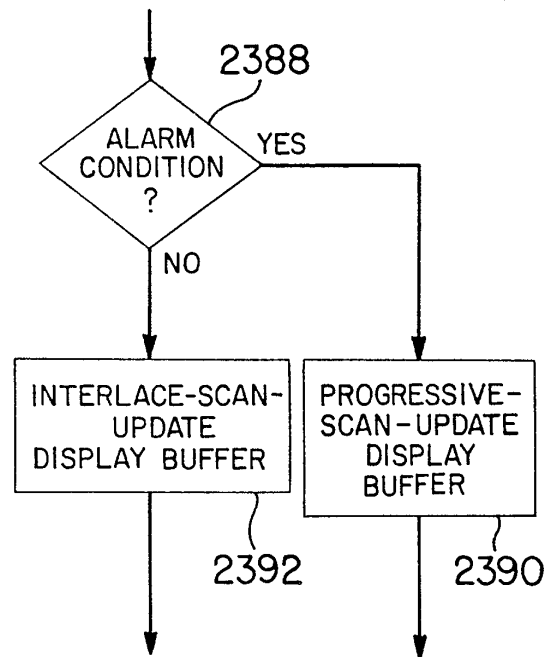
**FIG. 113**

ALARM-ACTUATED INCREASE  
IN AGGREGATE FIELD CAPTURE  
RATE



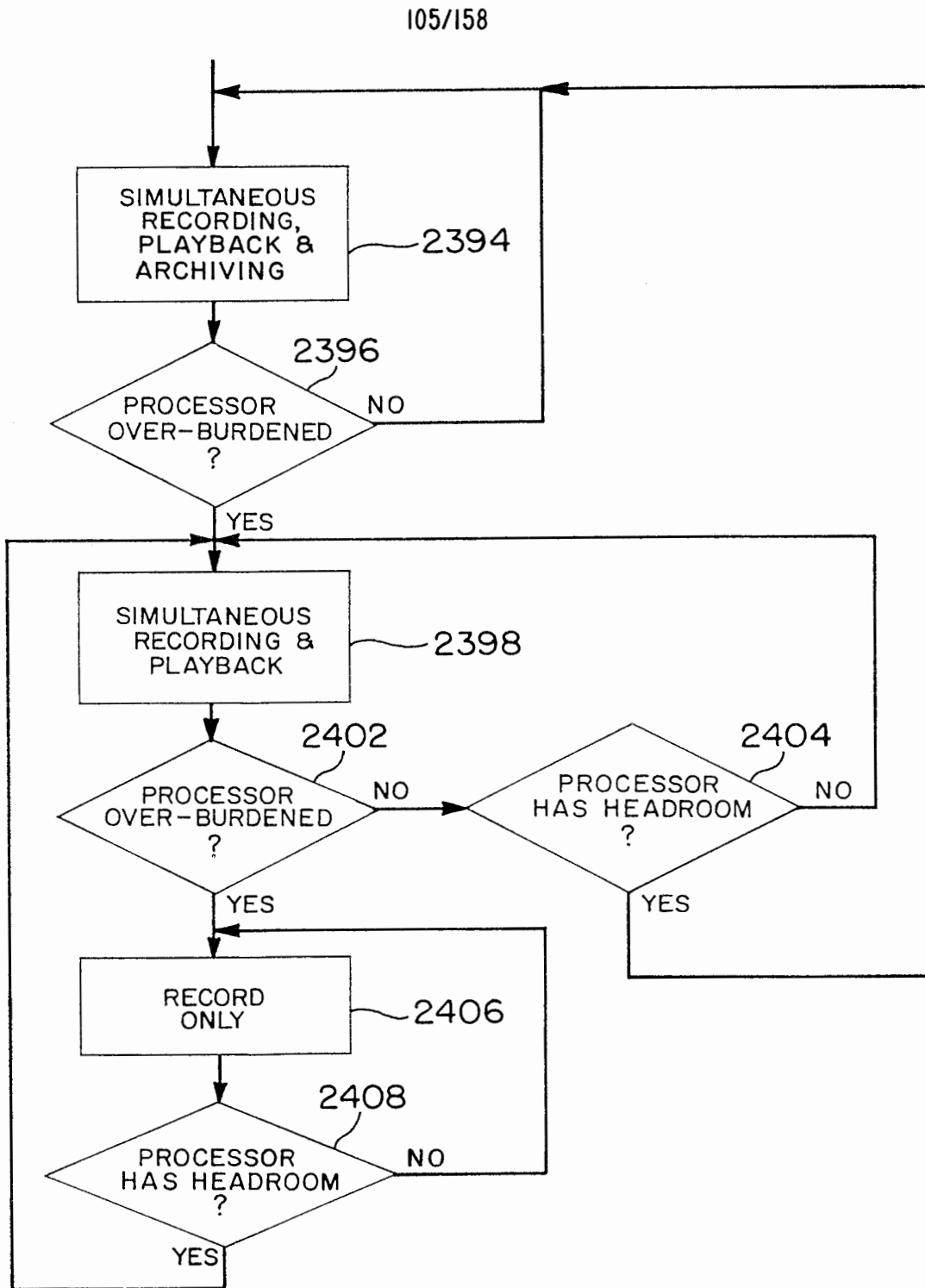
**FIG. 114**

VARYING  
COMPRESSION  
STREAM-BY-  
STREAM



**FIG. 115**

EVENT-SENSITIVE  
DISPLAY BUFFER  
UPDATING



**FIG. 116**

PRIORITIZING AMONG RECORDING/PLAYBACK/  
ARCHIVING

[REDACTED]

[REDACTED]

[REDACTED]

[REDACTED]

[REDACTED]

[REDACTED]

[REDACTED]

[REDACTED]

[REDACTED]

[REDACTED]

[REDACTED]

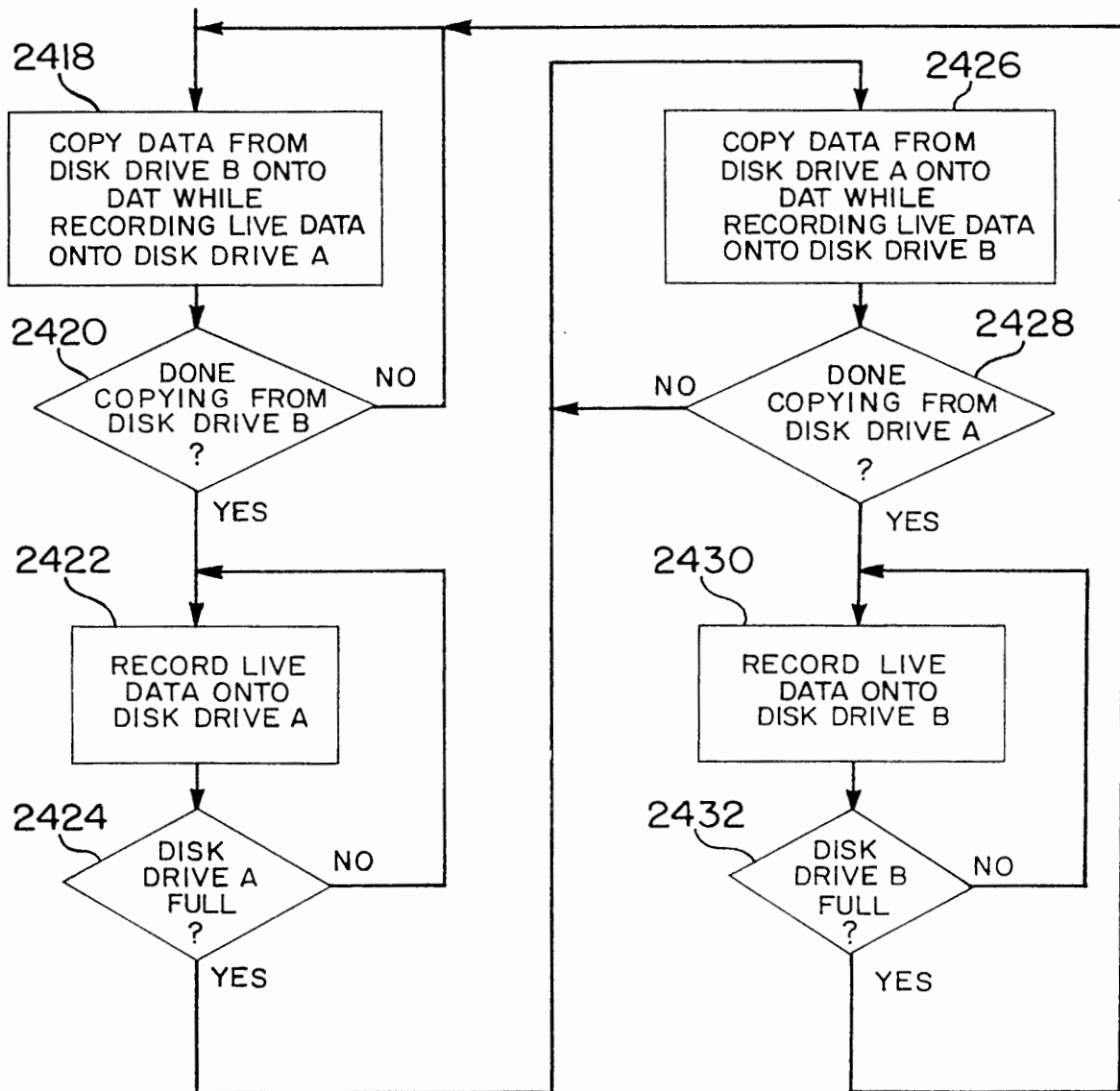
[REDACTED]

[REDACTED]

[REDACTED]

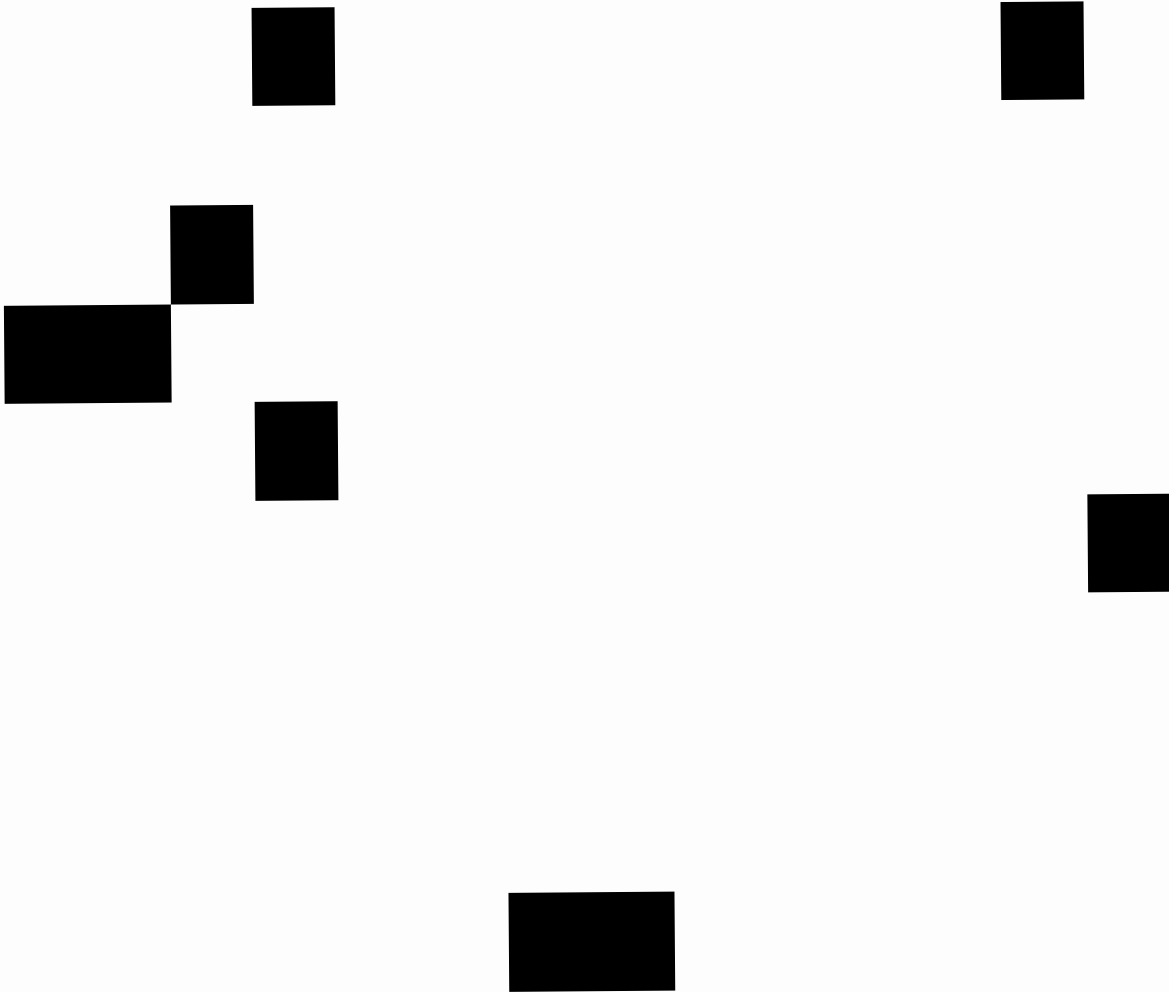
[REDACTED]

107/158

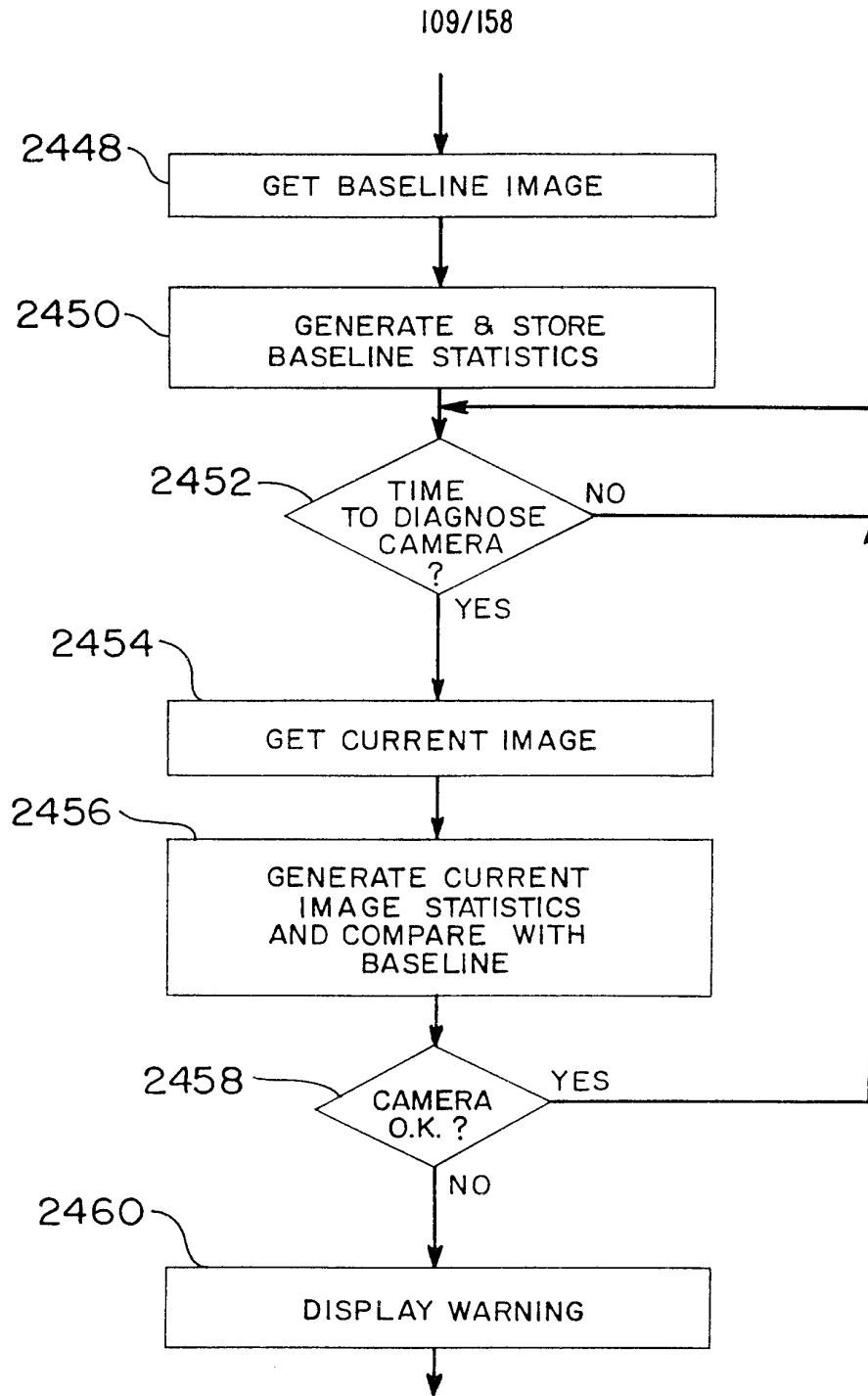


**FIG. 117B**

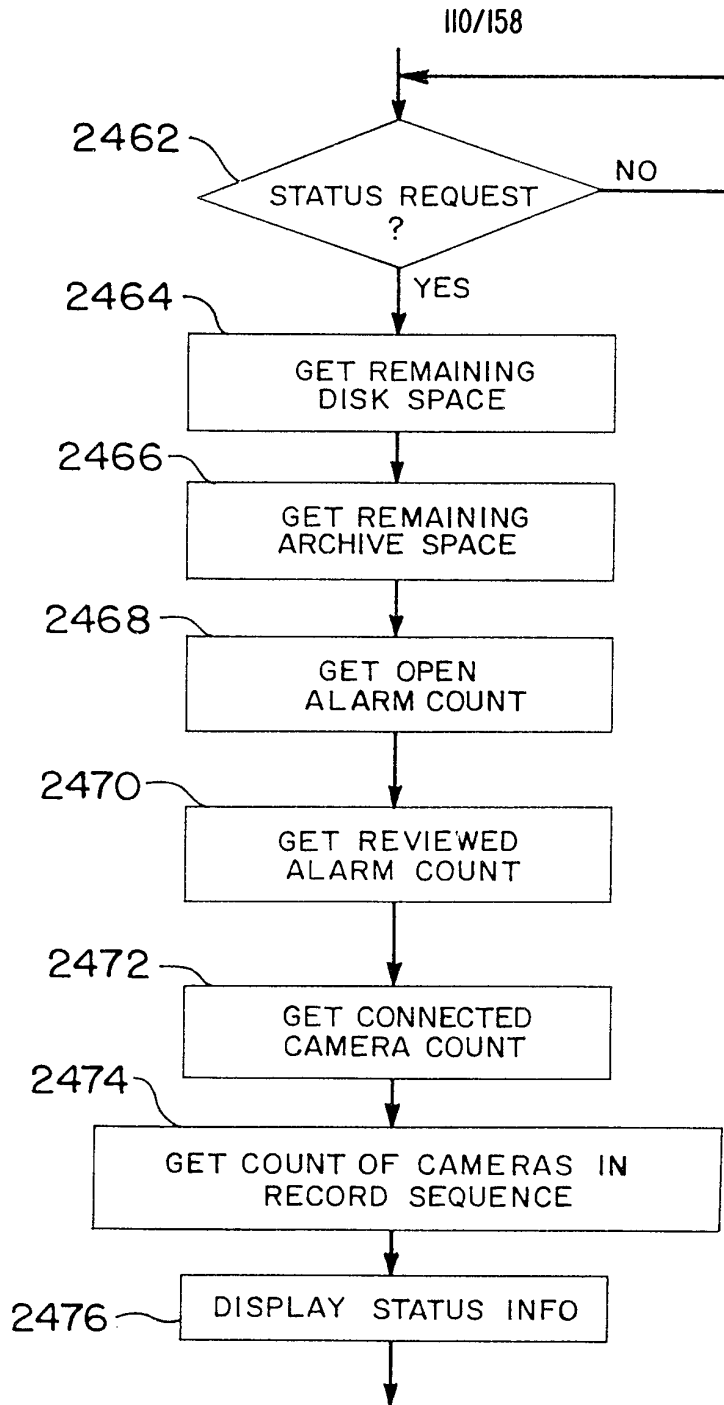
ARCHIVING SEQUENCE (ALTERNATIVE)







**FIG. 120**  
**CAMERA AUTO-DIAGNOSIS**



**FIG. 121**

BUILD STATUS DISPLAY

[REDACTED]

[REDACTED]

[REDACTED]

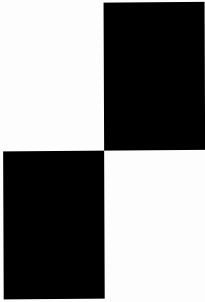
[REDACTED]

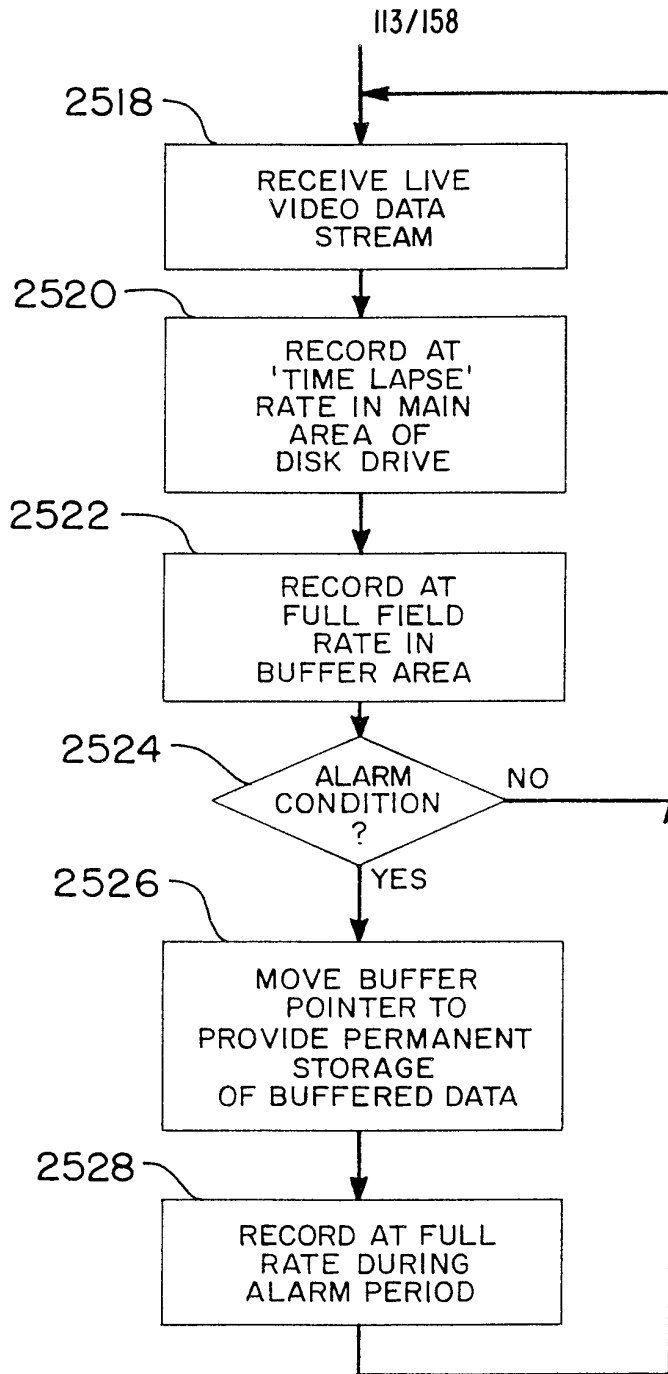
[REDACTED]

[REDACTED]

[REDACTED]

[REDACTED]





**FIG. 126**

FULL-RATE PRE-ALARM BUFFERING DURING TIME-LAPSE RECORDING





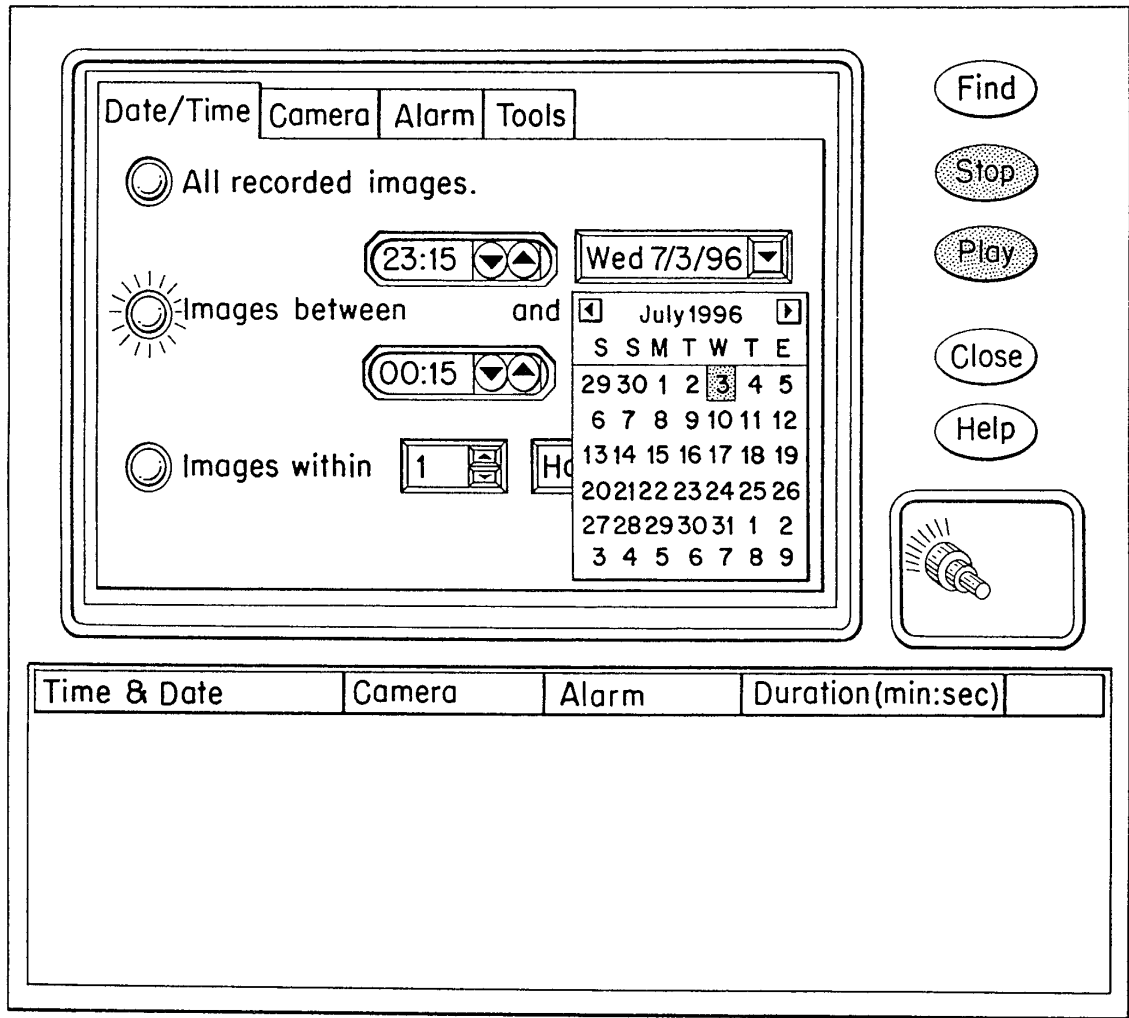


FIG. 130



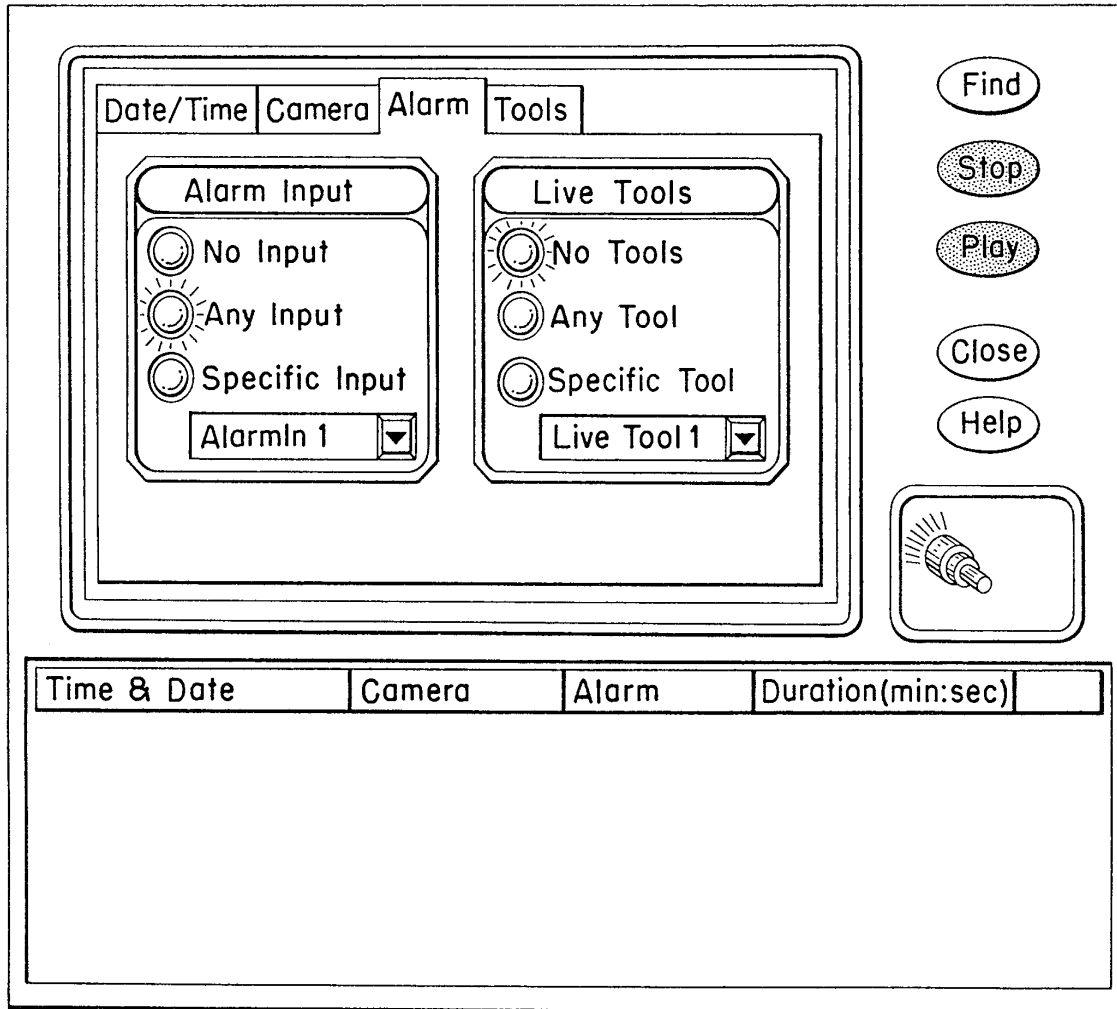
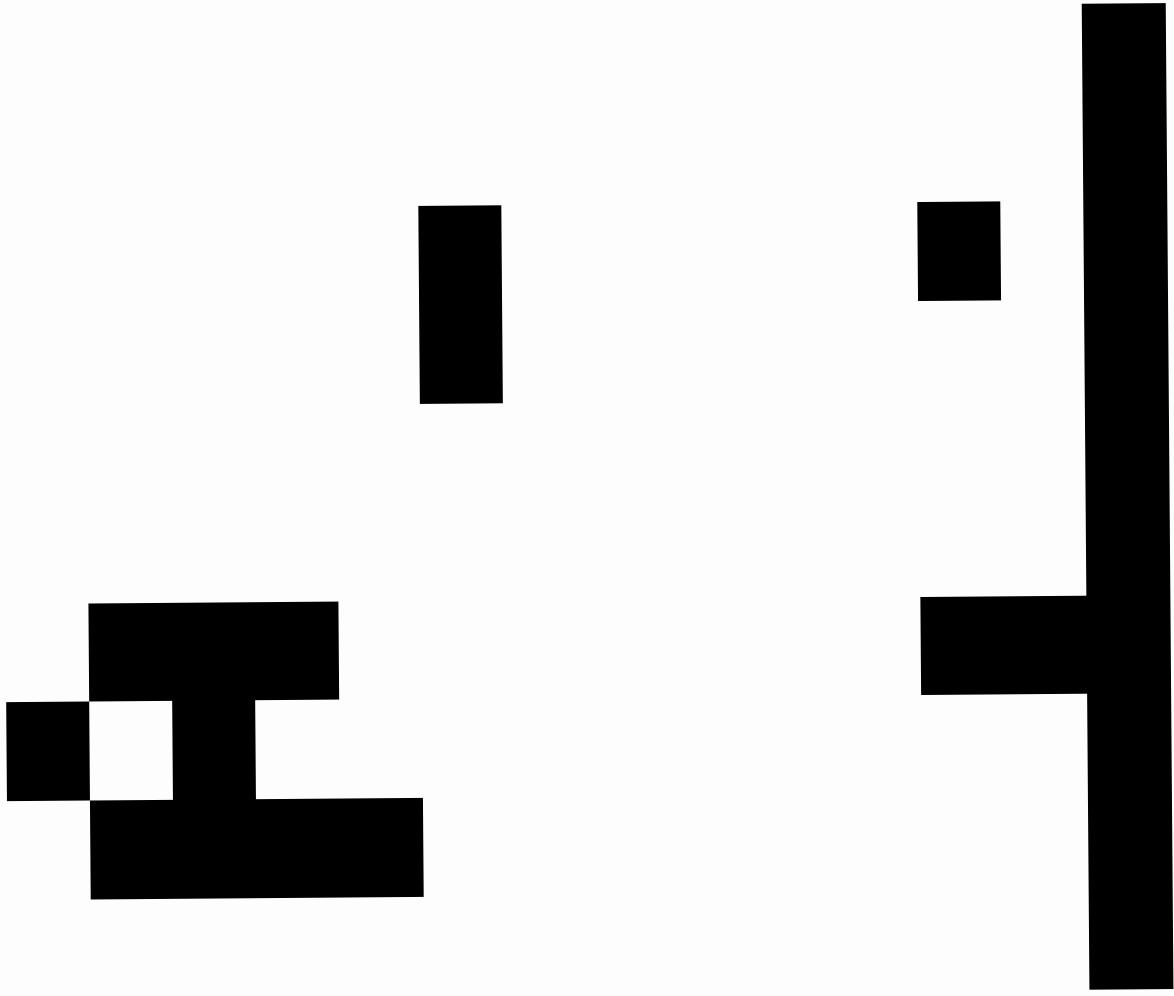
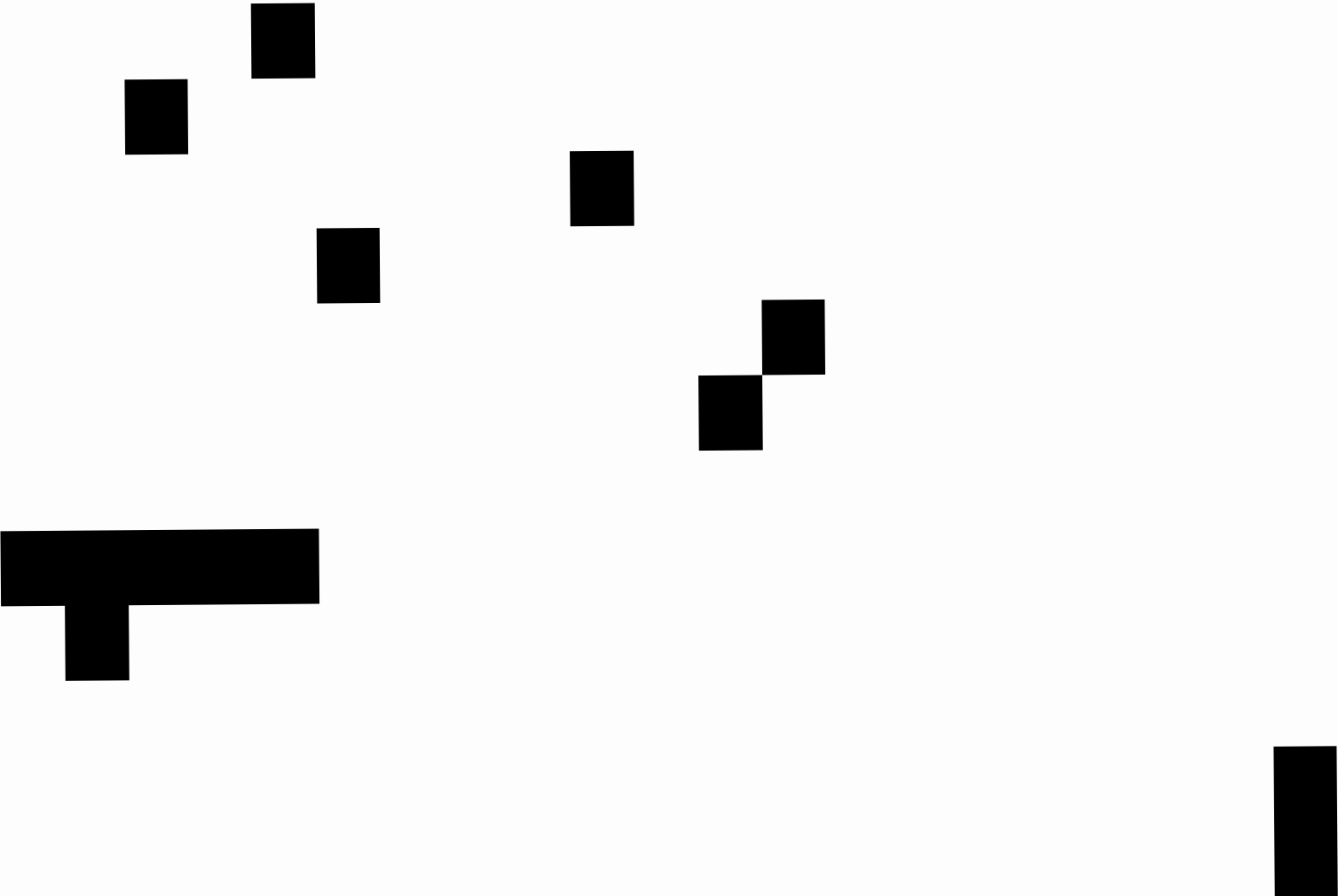
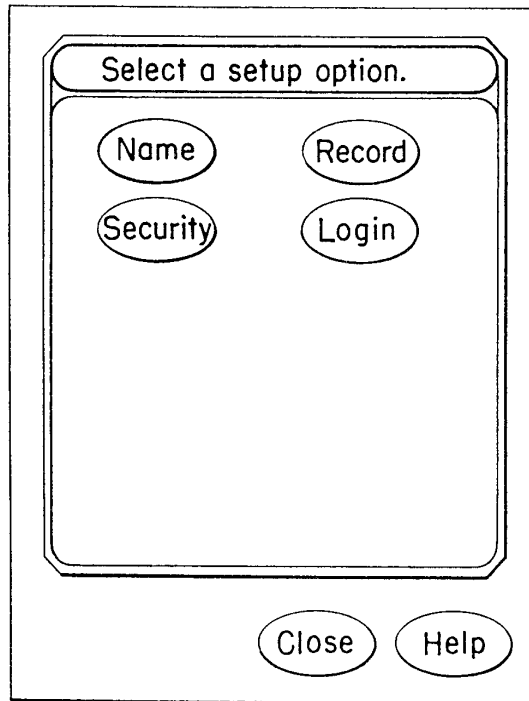


FIG. 131







*FIG. 134*

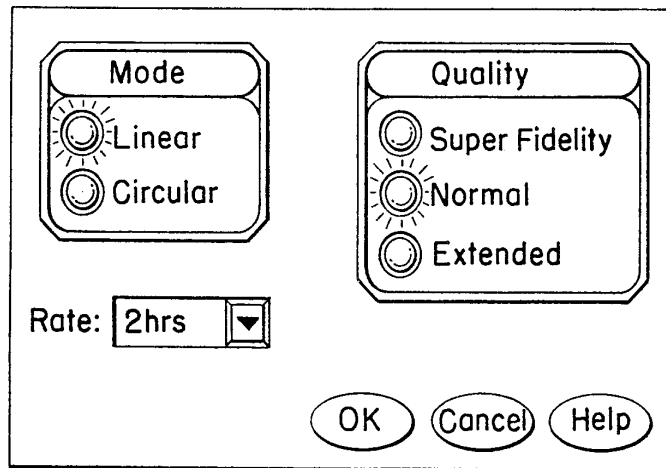


FIG. 135

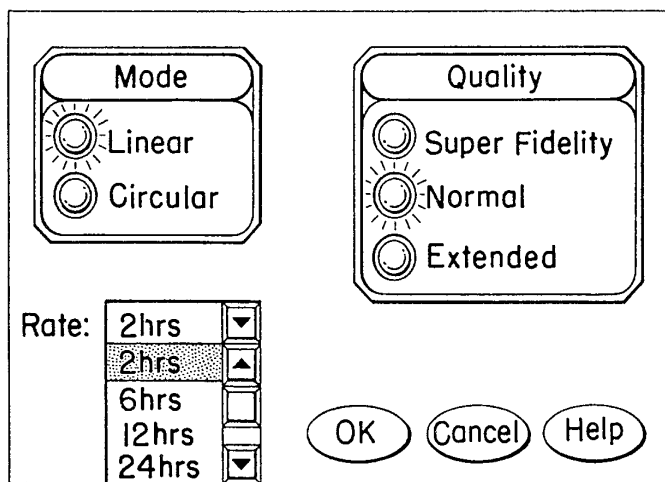
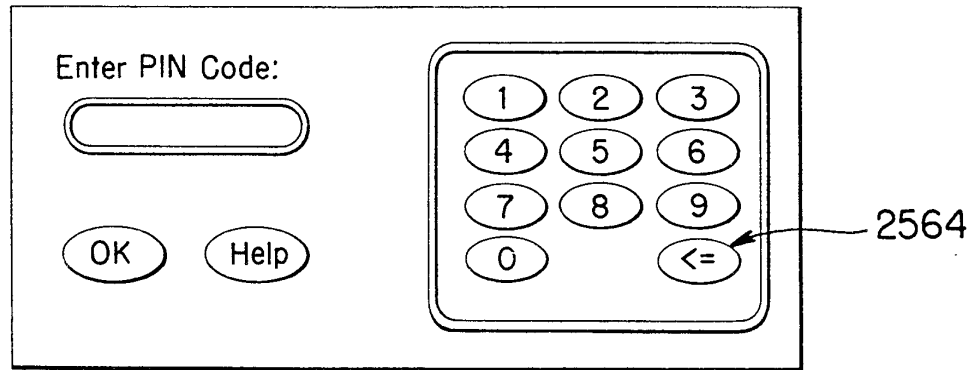


FIG. 136



123/158

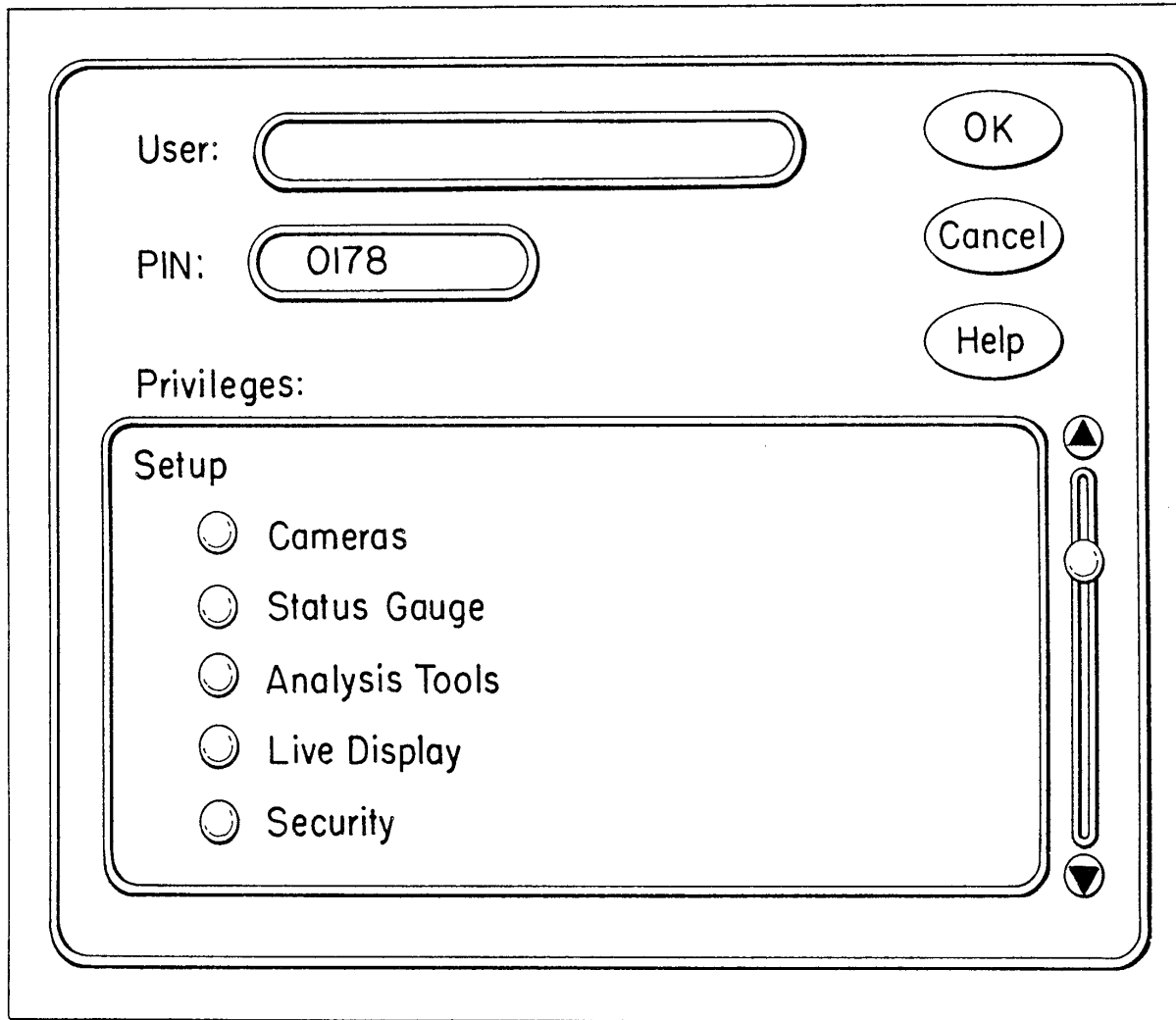
FIG. 137

[REDACTED]

[REDACTED]

[REDACTED]





**FIG. 139**

125/158

[REDACTED]

[REDACTED]

[REDACTED]

[REDACTED]

[REDACTED]

[REDACTED]



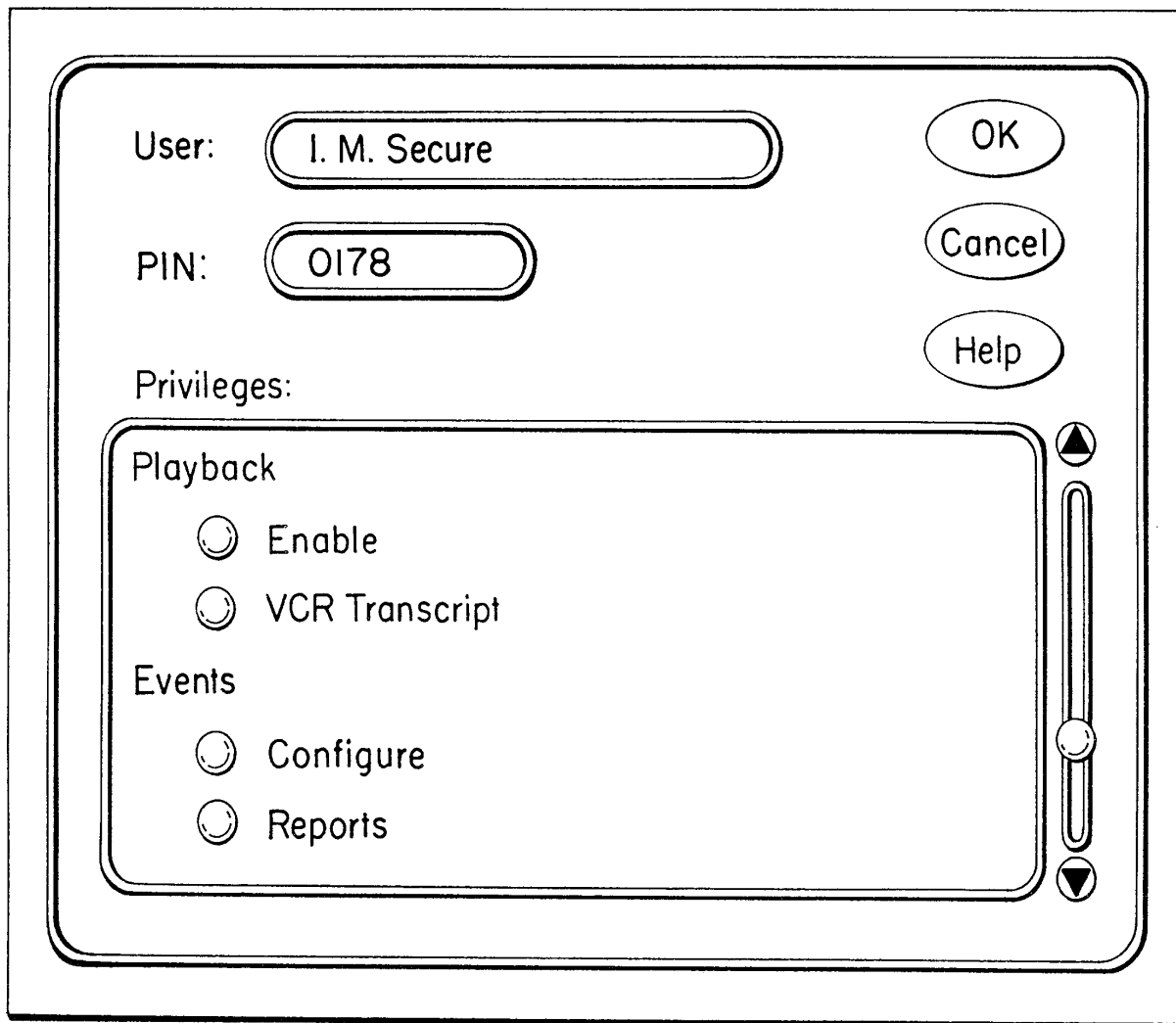


FIG. 142

128/158





[REDACTED]

[REDACTED]

[REDACTED]

[REDACTED]

[REDACTED]

[REDACTED]

[REDACTED]

[REDACTED]

[REDACTED]

[REDACTED]

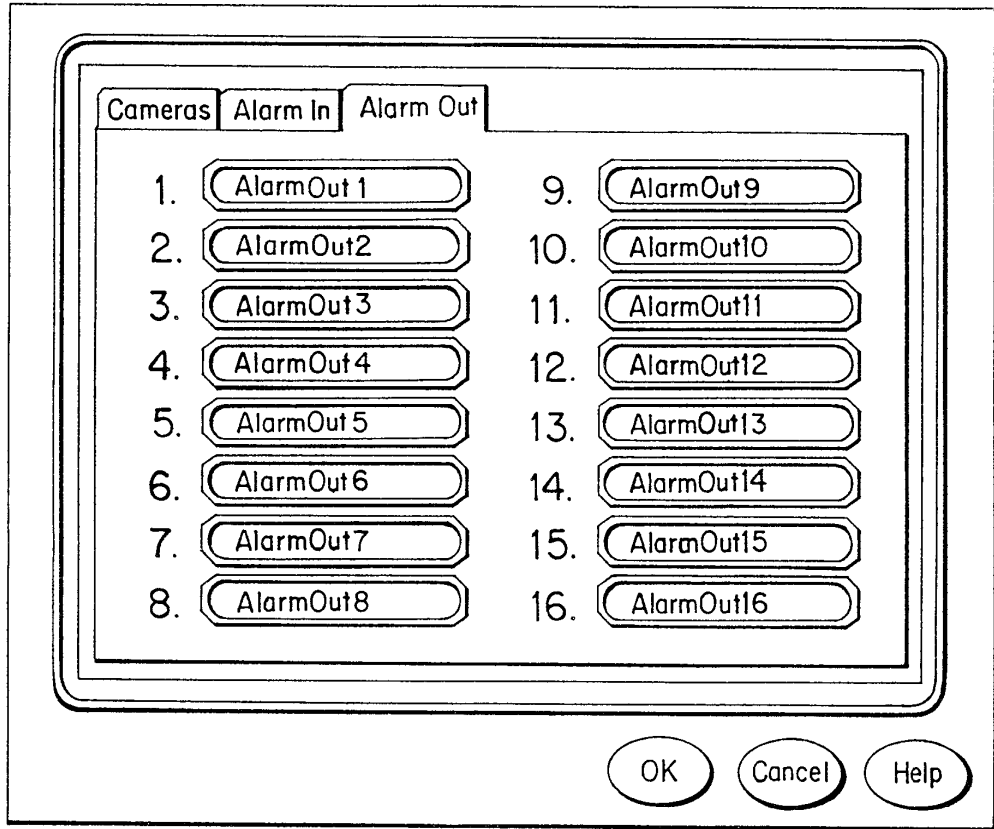


FIG. 146

132/158



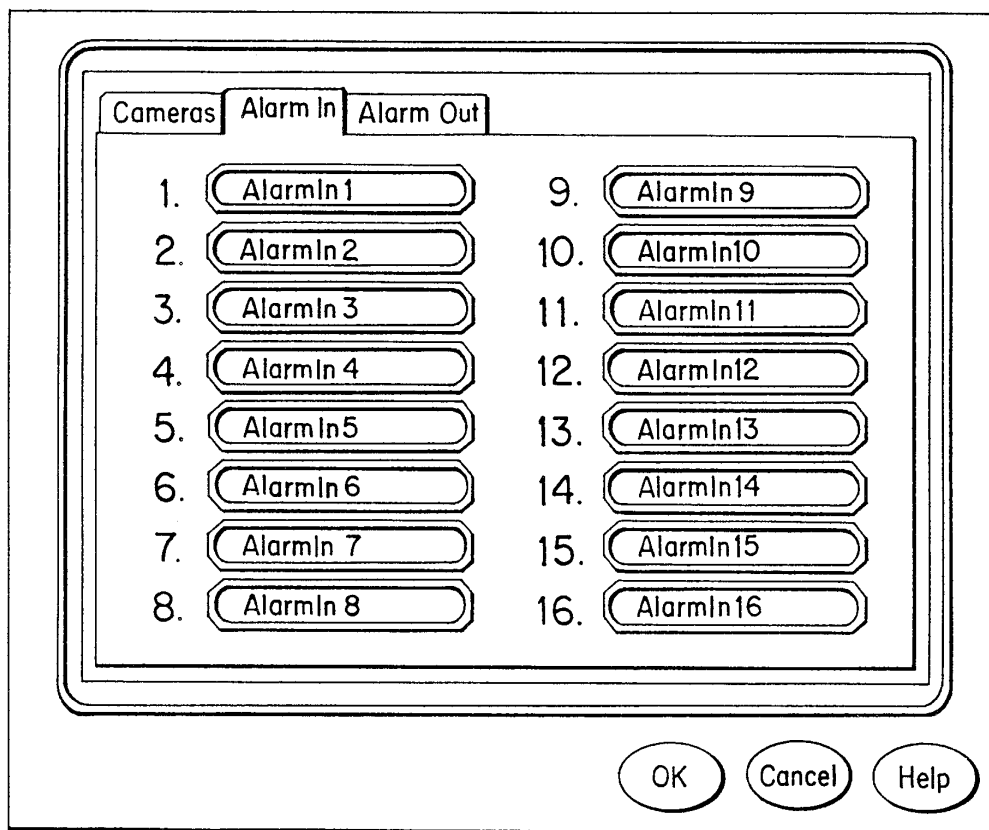


FIG. 147

133/158

[REDACTED]

[REDACTED]

[REDACTED]

[REDACTED]

[REDACTED]

[REDACTED]

[REDACTED]

[REDACTED]

[REDACTED]

[REDACTED]

[REDACTED]

[REDACTED]

[REDACTED]

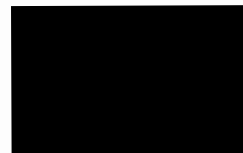
[REDACTED]

[REDACTED]

[REDACTED]

[REDACTED]

[REDACTED]



[REDACTED]

[REDACTED]

[REDACTED]

[REDACTED]

[REDACTED]

[REDACTED]

[REDACTED]

[REDACTED]

[REDACTED]

[REDACTED]

[REDACTED]

[REDACTED]

[REDACTED]

[REDACTED]

[REDACTED]

[REDACTED]

[REDACTED]

[REDACTED]

[REDACTED]

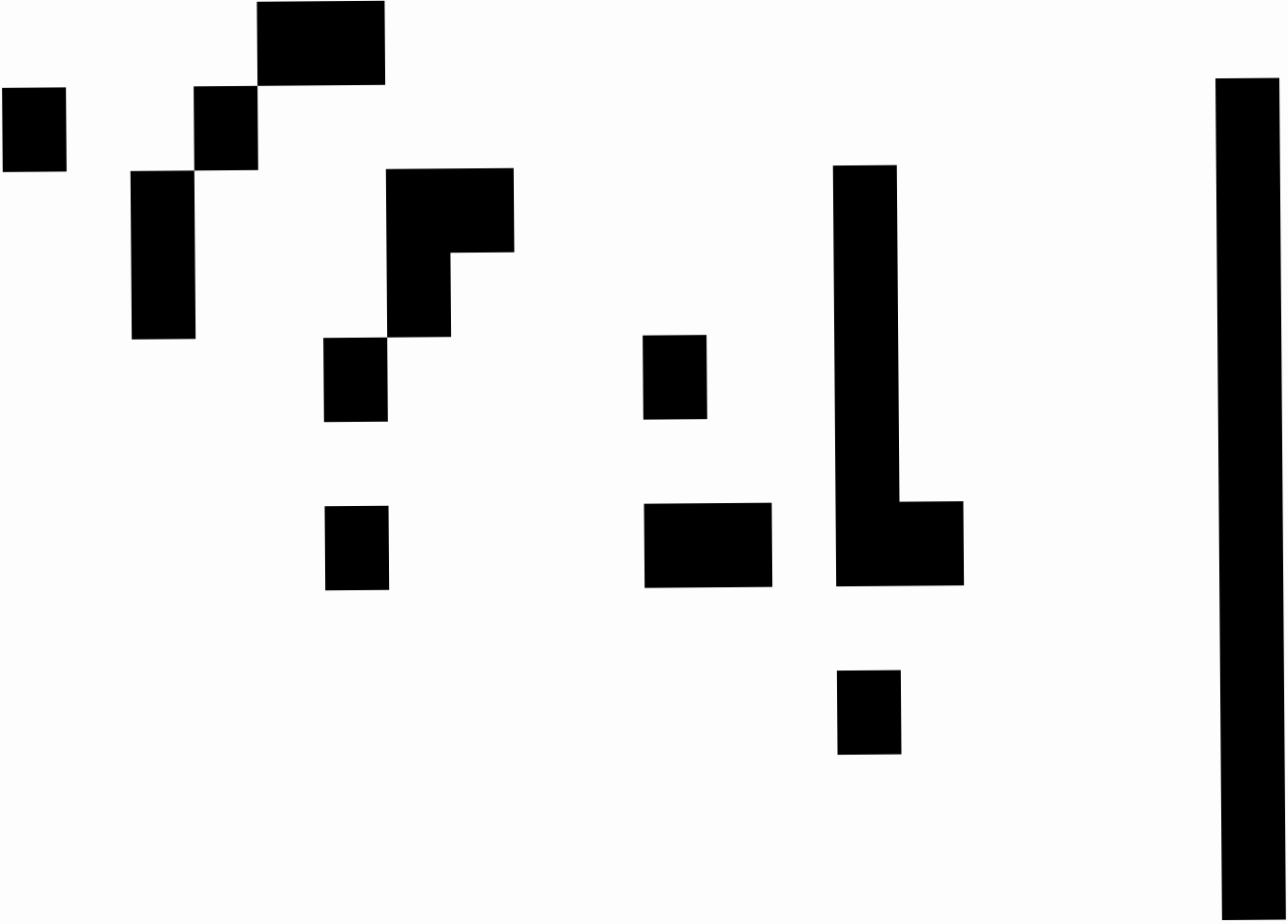
[REDACTED]

[REDACTED]

[REDACTED]

[REDACTED]

[REDACTED]



[REDACTED]

[REDACTED]

[REDACTED]

[REDACTED]

[REDACTED]

[REDACTED]

[REDACTED]

[REDACTED]

[REDACTED]



[REDACTED]

[REDACTED]

[REDACTED]

[REDACTED]

[REDACTED]

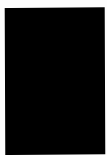
[REDACTED]

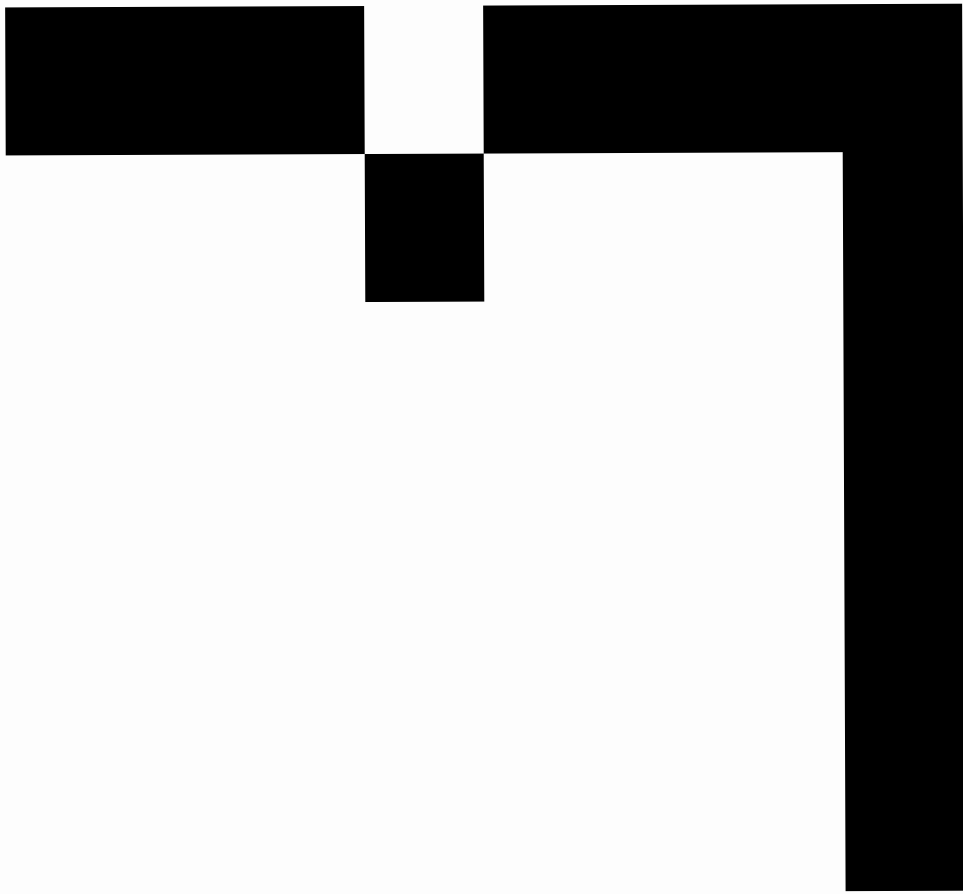
[REDACTED]

[REDACTED]

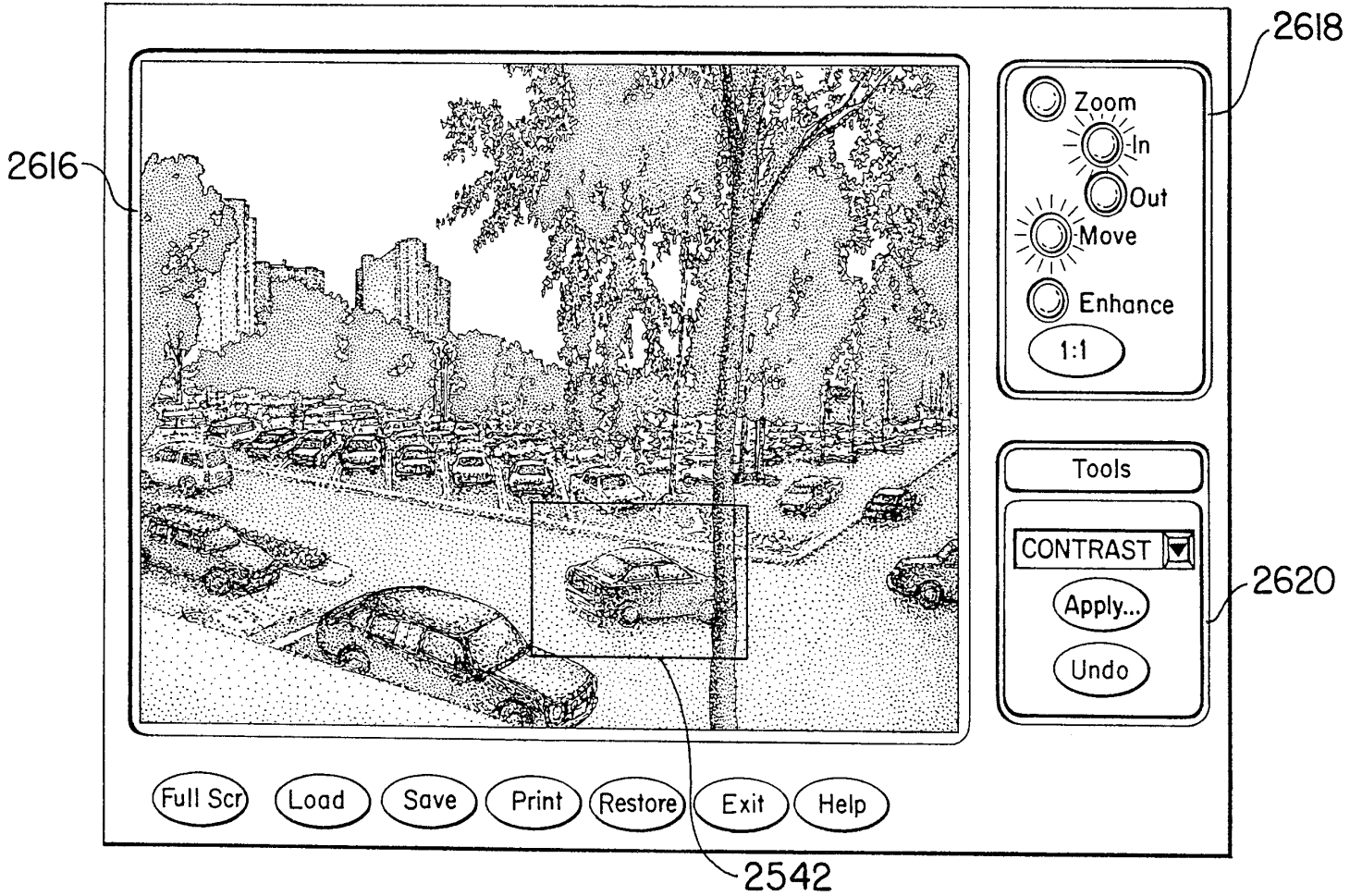
[REDACTED]











**FIG. 161**  
IMAGE PROCESSING UTILITY SCREEN

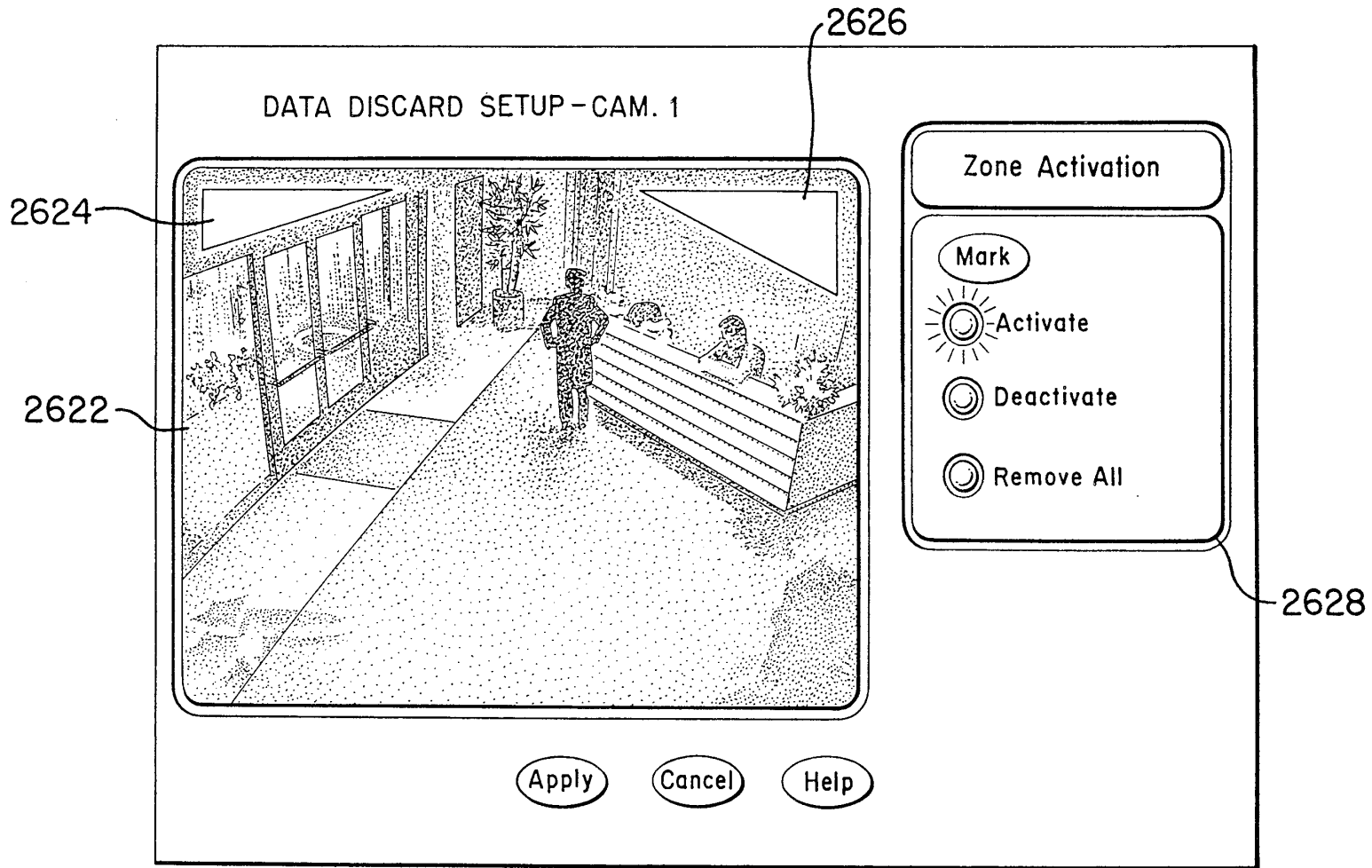
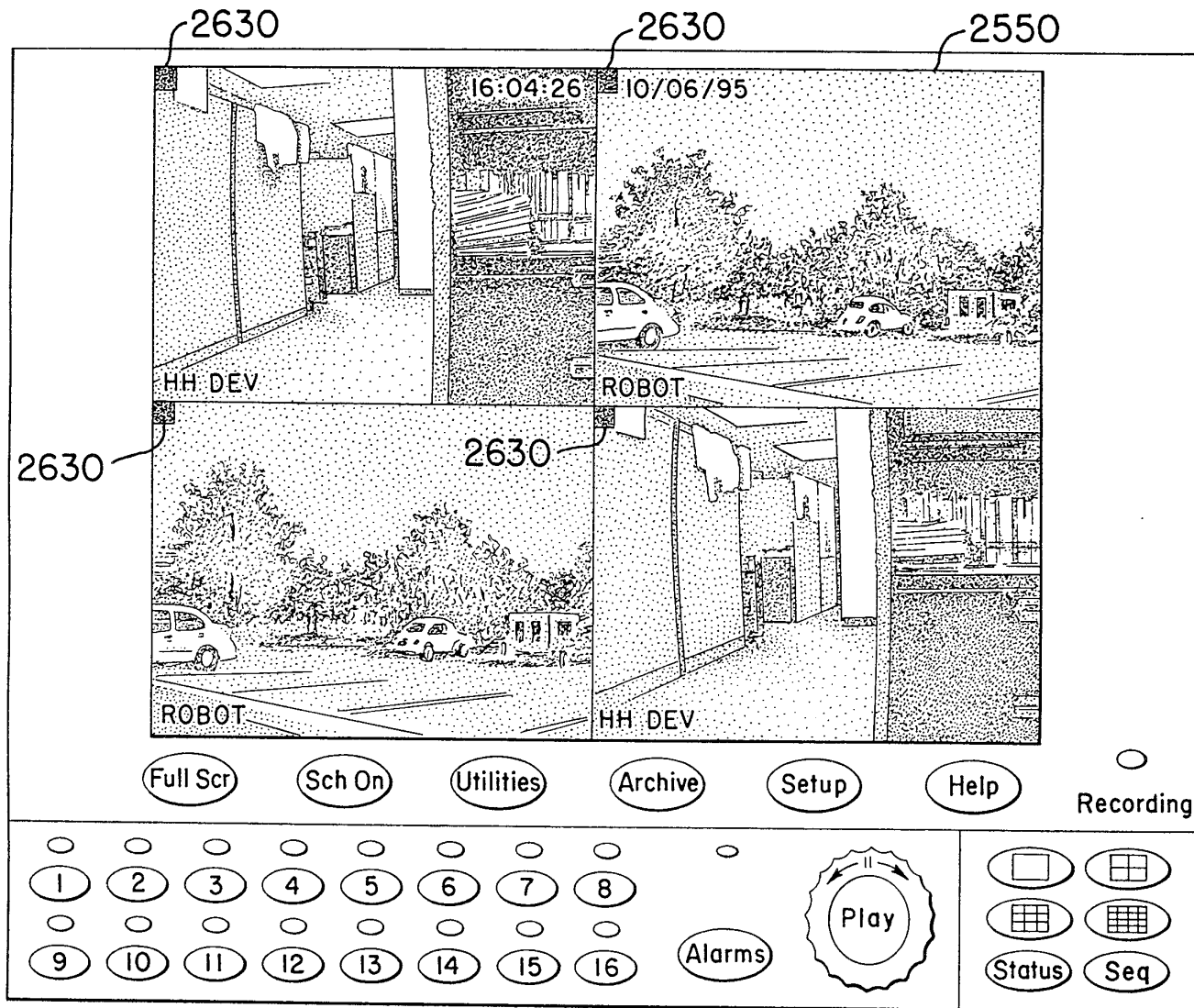


FIG. 162



WO 98/19450

148/158

PCT/US97/17886

FIG. 163





[REDACTED]

[REDACTED]

[REDACTED]

[REDACTED]

[REDACTED]

[REDACTED]

[REDACTED]

[REDACTED]

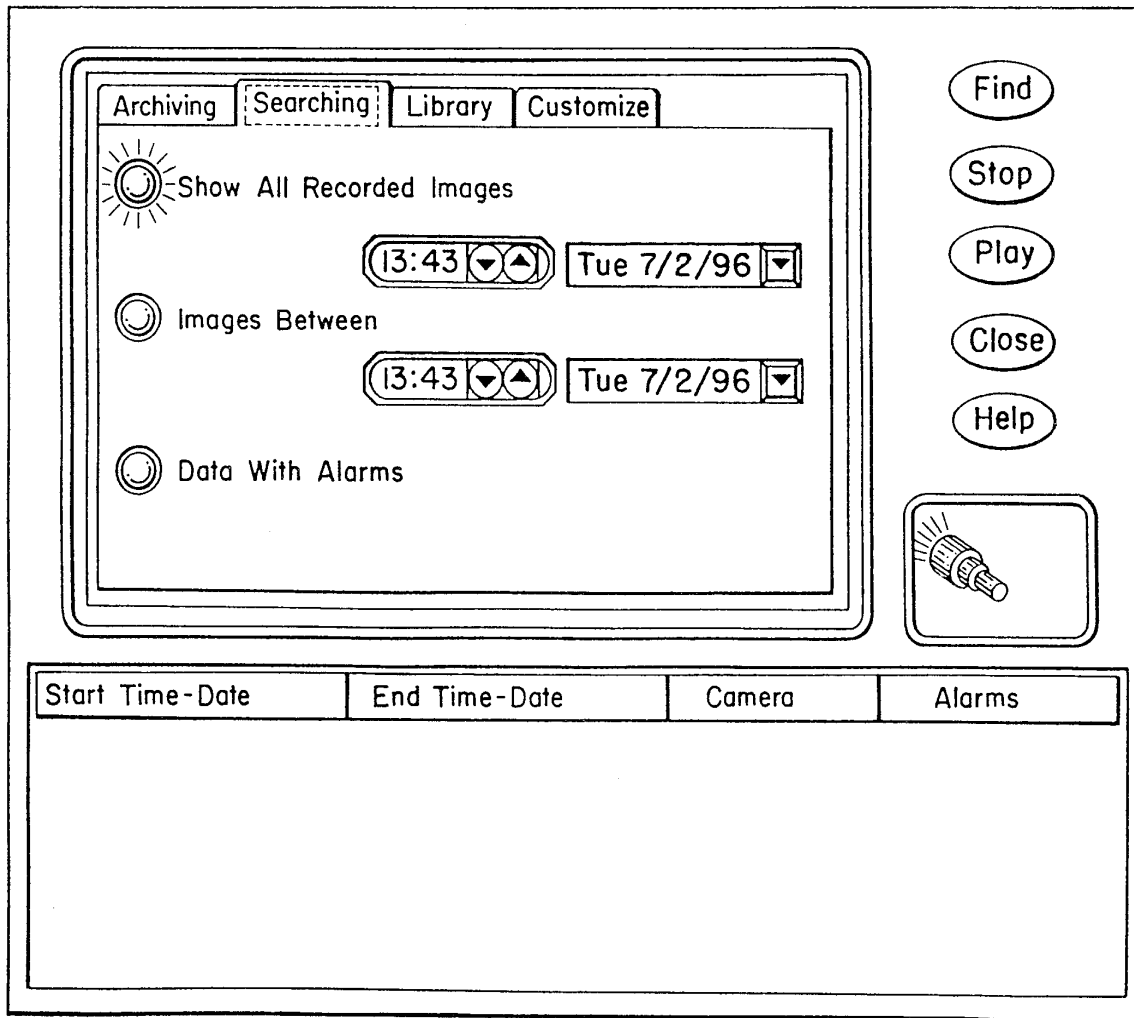


FIG. 166

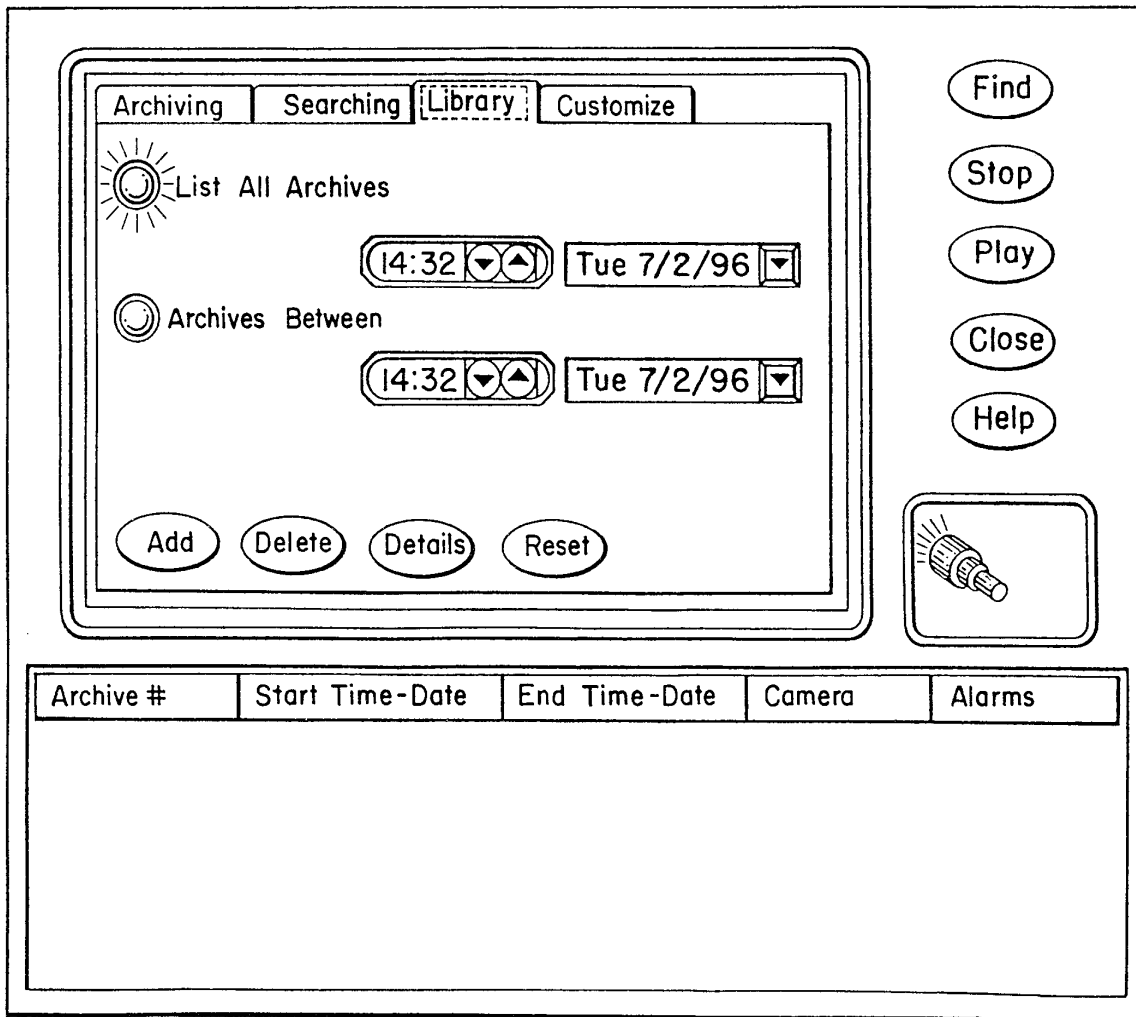


FIG. 167

152/158

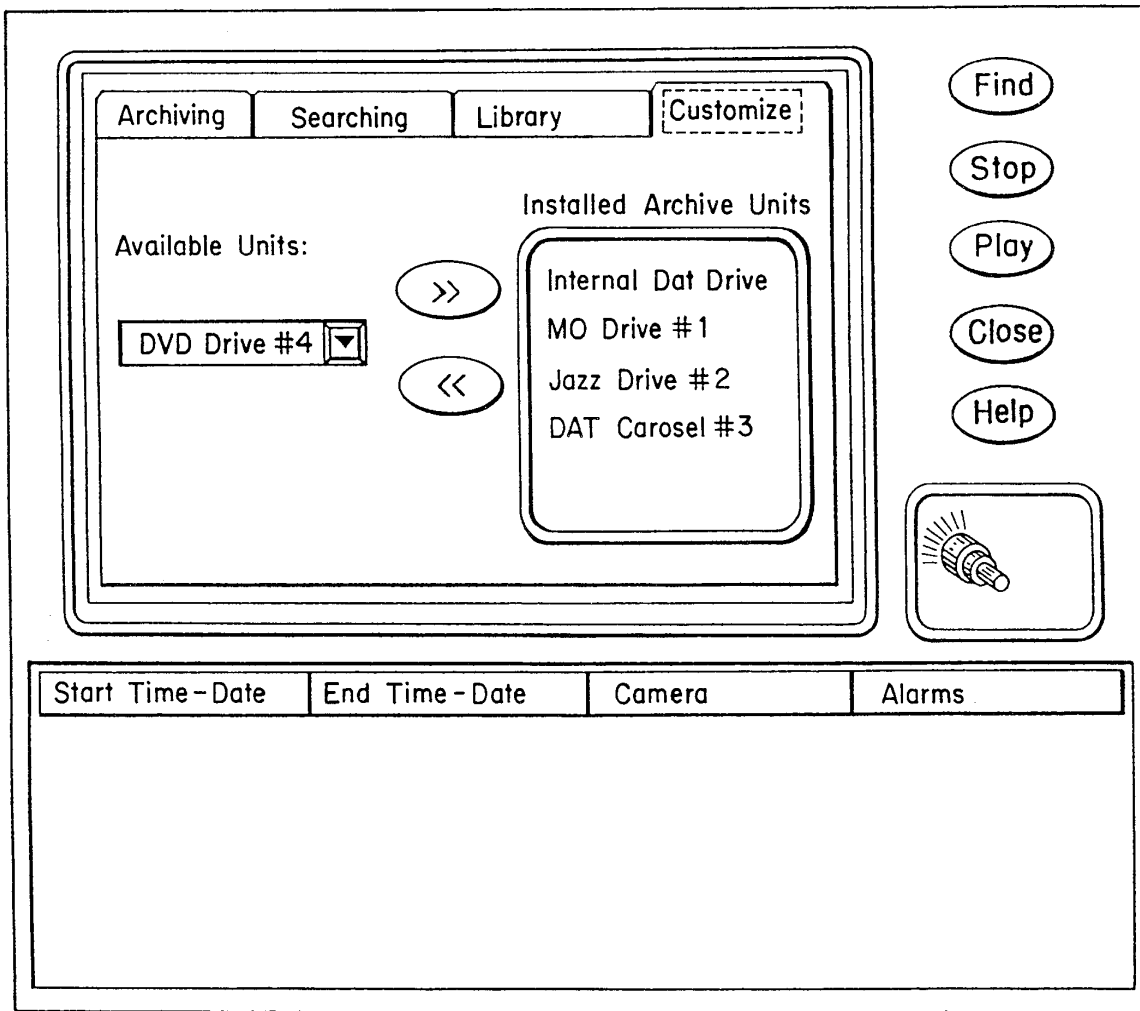


FIG. 168

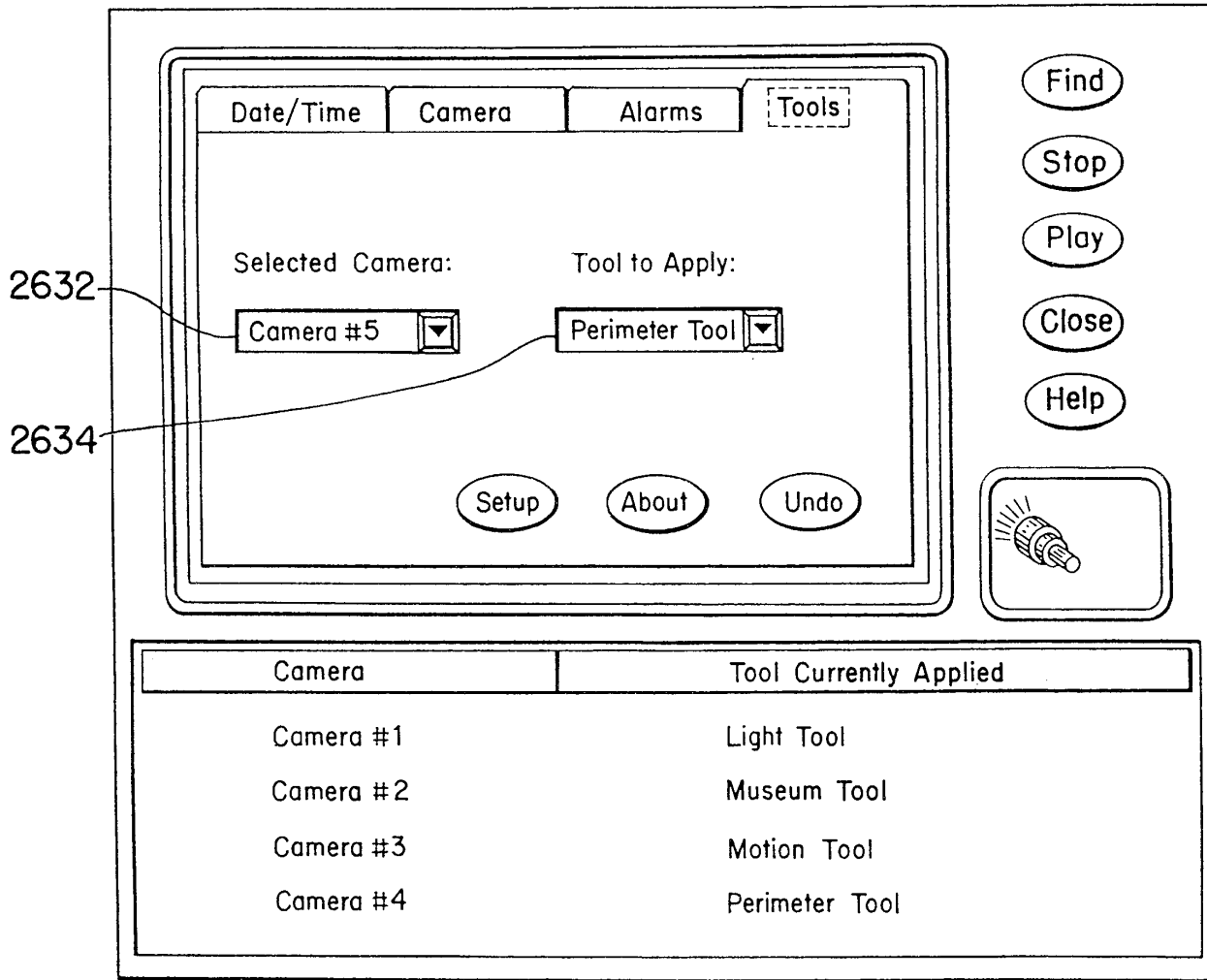
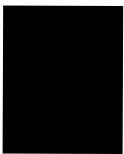
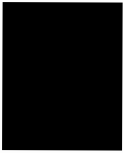


FIG. 169



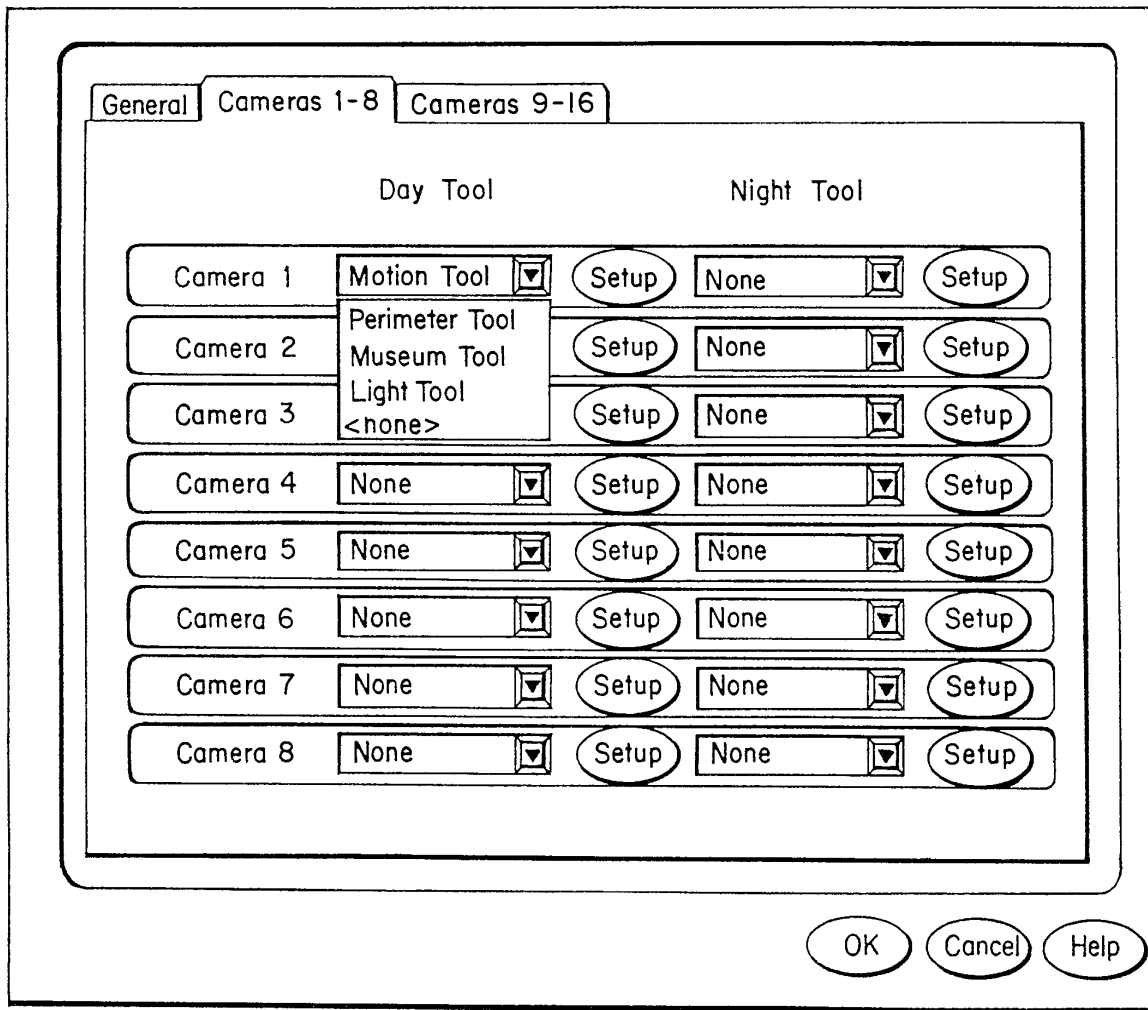
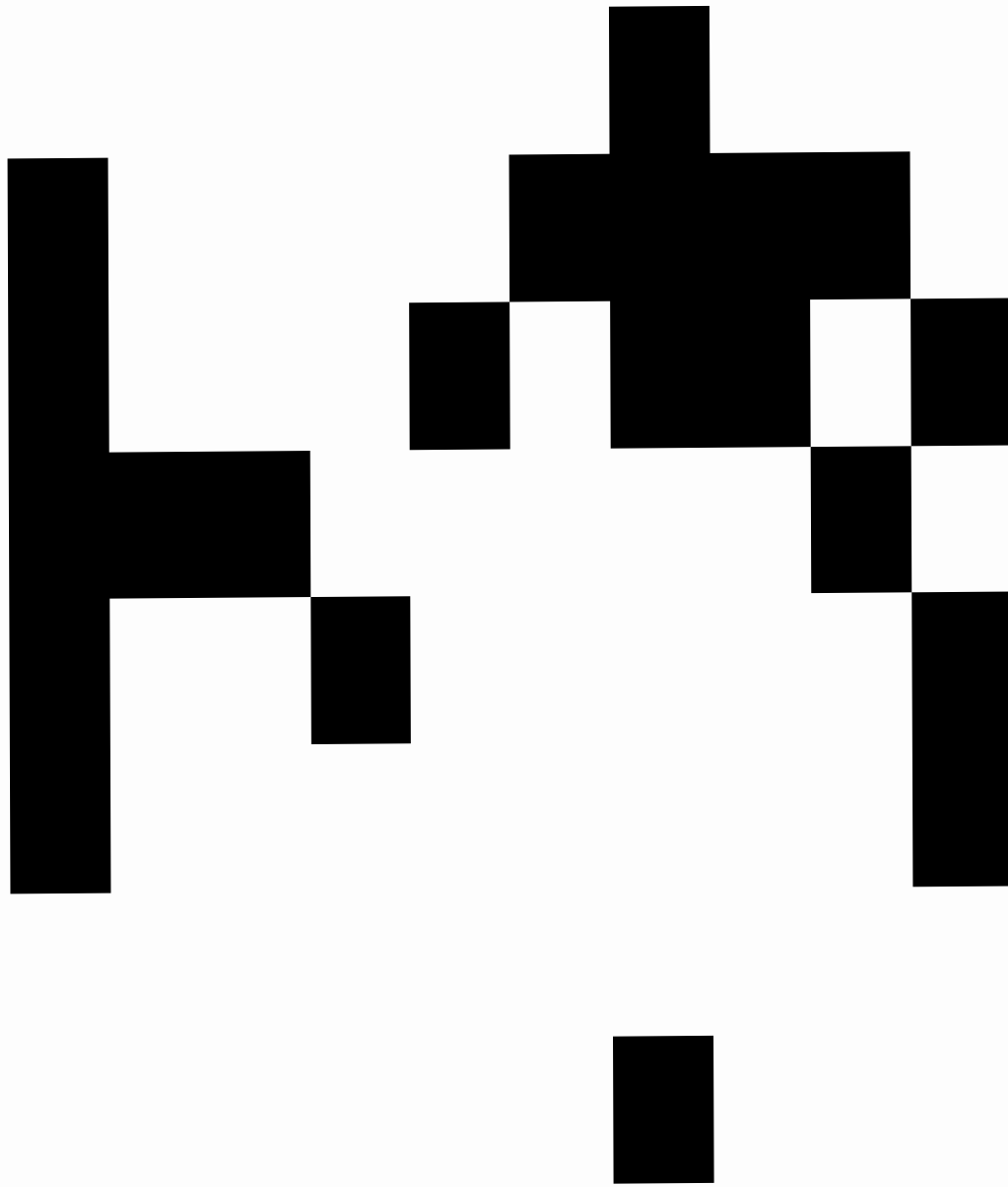



FIG. 171





158/158

**Sensormatic  
Video Digital Recorder**



Date:	08/28/96	Alarm:	On	System:	Local
Time:	16:22:24	Print Date:	08/28/96	ID:	4444
Camera:	Driveway	Print Time:	16:22:24		

2640

2642

**FIG. 173**

## Electronic Patent Application Fee Transmittal

<b>Application Number:</b>	14876276			
<b>Filing Date:</b>	06-Oct-2015			
<b>Title of Invention:</b>	Video Data Compression Systems			
<b>First Named Inventor/Applicant Name:</b>	James J. FALLON			
<b>Filer:</b>	Michael V. Messinger/William Flanigen			
<b>Attorney Docket Number:</b>	3421.005000C			
Filed as Large Entity				
<b>Filing Fees for Utility under 35 USC 111(a)</b>				
<b>Description</b>	<b>Fee Code</b>	<b>Quantity</b>	<b>Amount</b>	<b>Sub-Total in USD(\$)</b>
<b>Basic Filing:</b>				
<b>Pages:</b>				
<b>Claims:</b>				
<b>Miscellaneous-Filing:</b>				
<b>Petition:</b>				
<b>Patent-Appeals-and-Interference:</b>				
<b>Post-Allowance-and-Post-Issuance:</b>				
<b>Extension-of-Time:</b>				

Description	Fee Code	Quantity	Amount	Sub-Total in USD(\$)
<b>Miscellaneous:</b>				
Submission- Information Disclosure Stmt	1806	1	180	180
<b>Total in USD (\$)</b>				<b>180</b>

## Electronic Acknowledgement Receipt

<b>EFS ID:</b>	24786023
<b>Application Number:</b>	14876276
<b>International Application Number:</b>	
<b>Confirmation Number:</b>	3403
<b>Title of Invention:</b>	Video Data Compression Systems
<b>First Named Inventor/Applicant Name:</b>	James J. FALLON
<b>Customer Number:</b>	26111
<b>Filer:</b>	Michael V. Messinger/William Flanigen
<b>Filer Authorized By:</b>	Michael V. Messinger
<b>Attorney Docket Number:</b>	3421.005000C
<b>Receipt Date:</b>	01-FEB-2016
<b>Filing Date:</b>	06-OCT-2015
<b>Time Stamp:</b>	18:11:58
<b>Application Type:</b>	Utility under 35 USC 111(a)

### Payment information:

Submitted with Payment	yes
Payment Type	Credit Card
Payment was successfully received in RAM	\$180
RAM confirmation Number	5264
Deposit Account	
Authorized User	

The Director of the USPTO is hereby authorized to charge indicated fees and credit any overpayment as follows:

<b>File Listing:</b>					
<b>Document Number</b>	<b>Document Description</b>	<b>File Name</b>	<b>File Size(Bytes)/ Message Digest</b>	<b>Multi Part /.zip</b>	<b>Pages (if appl.)</b>
1		3421005000C_3SIDS.pdf	1927599 c0e49b4df8a68d1acb88f02af7249852cb7e8b20	yes	13
<b>Multipart Description/PDF files in .zip description</b>					
	<b>Document Description</b>		<b>Start</b>	<b>End</b>	
	Miscellaneous Incoming Letter		1	1	
	Transmittal Letter		2	8	
	Information Disclosure Statement (IDS) Form (SB08)		9	13	
<b>Warnings:</b>					
<b>Information:</b>					
2	Foreign Reference	FP1_WO9819450.pdf	22639052 da7f8e2949dd076dc6e47142bebdd627b96606ea	no	521
<b>Warnings:</b>					
<b>Information:</b>					
3	Non Patent Literature	NPL1_Adoption_of_Magistrate_Judge_Report_01212016.pdf	161998 d72f1f2313f10cc1a1b96bea1bf573319e690f64	no	4
<b>Warnings:</b>					
<b>Information:</b>					
4	Non Patent Literature	NPL2_Invalidity_Contentions_1_2042015.pdf	421088 abb1939b11ee040510aaf52f669dbbd83b2884c1	no	138
<b>Warnings:</b>					
<b>Information:</b>					
5	Non Patent Literature	NPL3_Invalidity_Contentions_A_Exhibits_12042015.pdf	4755869 63b47dccc842ed7a3deb7bb0e9c625db23bdc3cd	no	743
<b>Warnings:</b>					
<b>Information:</b>					
6	Non Patent Literature	NPL4_Invalidity_Contentions_B_Exhibits_12042015.pdf	5963669 8beb07705c7616246b1ccd35c9e13542489bf56d	no	506

<b>Warnings:</b>					
<b>Information:</b>					
7	Non Patent Literature	NPL5_Invalidity_Contentions_C_Exhibits_12042015.pdf	13073654 67d8813b18f6bd52fb4477f67a895fb0ddc2d8f3	no	1445
<b>Warnings:</b>					
<b>Information:</b>					
8	Non Patent Literature	NPL6_Invalidity_Contentions_D_Exhibits_12042015.pdf	7235650 fb67c9dc76a8d7aee54513e35b560398a510bce0	no	1052
<b>Warnings:</b>					
<b>Information:</b>					
9	Non Patent Literature	NPL7_Invalidity_Contentions_E_Exhibits_12042015.pdf	12056354 11fcb9db81409882ed6c51aa21ee9f70fb0650fb	no	1205
<b>Warnings:</b>					
<b>Information:</b>					
10	Non Patent Literature	NPL8_Katz_1996.pdf	1104369 4c332a4db25dc225ce0eecd2c4e6490aebdce73	no	6
<b>Warnings:</b>					
<b>Information:</b>					
11	Non Patent Literature	NPL9_Prov_Appl_60100671.pdf	1715416 06e70e86cf1ed0348220893935a013b66e824a47	no	50
<b>Warnings:</b>					
<b>Information:</b>					
12	Non Patent Literature	NPL10_Welch_1984.pdf	6610422 15957c2a8dc85e5066e393da9ab70883876521ea	no	12
<b>Warnings:</b>					
<b>Information:</b>					
13	Non Patent Literature	NPL11_iMatix_Internet_Archive_05201998.pdf	125152 146558cdf223dc9942eb746e35ef997ddb8356e	no	1
<b>Warnings:</b>					
<b>Information:</b>					
14	Non Patent Literature	NPL12_iMatix_Internet_Archive_01101998.pdf	109142 a9486edbb3b68c177982e24fb1c63caae92bdd5	no	1
<b>Warnings:</b>					
<b>Information:</b>					
15	Non Patent Literature	NPL13_iMatix_Internet_Archive_01091998.pdf	109415 6cb3ac922228fc9800a4a6fd6d5d9a0c833f3ab	no	1

<b>Warnings:</b>					
<b>Information:</b>					
16	Non Patent Literature	NPL14_iMatix_Internet_Archiv e_10141997.pdf	100532 178cd8a1a11fc94a32d406b172c0e84aa4f9 4a01	no	1
<b>Warnings:</b>					
<b>Information:</b>					
17	Non Patent Literature	NPL15_iMatix_Internet_Archiv e_06291997.pdf	171740 bf3f39cbf088f9beab00d587863a420be09b a407	no	2
<b>Warnings:</b>					
<b>Information:</b>					
18	Non Patent Literature	NPL16_iMatix_Internet_Archiv e_04161997.pdf	161919 335471069489cdba0218af88ffc66fdffe075 48c	no	2
<b>Warnings:</b>					
<b>Information:</b>					
19	Non Patent Literature	NPL17_iMatix_Internet_Archiv e_12211996.pdf	177877 c585d641ca9169ae392d4eeb2f54417e3d6 0f62	no	2
<b>Warnings:</b>					
<b>Information:</b>					
20	Non Patent Literature	NPL18_iMatix_Internet_Archiv e_11061996.pdf	187844 f415e86b5589a6f5ded0deb70816403b95f 8a812	no	2
<b>Warnings:</b>					
<b>Information:</b>					
21	Non Patent Literature	NPL19_Legacy_iMatix_Newslet ter_091998.pdf	682811 1dc18f1fd3ebf5d92f7b86f7e60328a4446e 87bd	no	9
<b>Warnings:</b>					
<b>Information:</b>					
22	Non Patent Literature	NPL20_Legacy_iMatix_Newslet ter_041998.pdf	674363 1e5149a6a9c00d148a4bd8ee66e398981b8 03744	no	8
<b>Warnings:</b>					
<b>Information:</b>					
23	Non Patent Literature	NPL21_Legacy_iMatix_Newslet ter_011998.pdf	578206 81624ac1a5cc1ec2ae0f693313d64c47101 9ad3	no	7
<b>Warnings:</b>					
<b>Information:</b>					
24	Non Patent Literature	NPL22_Legacy_iMatix_Newslet ter_081997.pdf	581593 baa35df686477292f70f2a90639fb34d3dfa 6d4f	no	8



<b>Warnings:</b>					
<b>Information:</b>					
25	Non Patent Literature	NPL23_Legacy_iMatix_Newsletter_061997.pdf	456074 f64a685ce38b1fb3d5308baf1c9d29909151f552	no	6
<b>Warnings:</b>					
<b>Information:</b>					
26	Non Patent Literature	NPL24_Legacy_iMatix_Newsletter_021997.pdf	660568 3bf48a453b58d6f777dca69241c7e7d028ce3e0	no	9
<b>Warnings:</b>					
<b>Information:</b>					
27	Non Patent Literature	NPL25_SEAS_UPenn_Internet_Archive_10051999.pdf	263635 0ff6c7c6f60a46e34b7a70aa3697384d4a72270	no	2
<b>Warnings:</b>					
<b>Information:</b>					
28	Non Patent Literature	NPL26_SEAS_UPenn_Internet_Archive_01182000.pdf	258314 ae019ef577c30323bf85c63dcbefae4dfa57333	no	2
<b>Warnings:</b>					
<b>Information:</b>					
29	Non Patent Literature	NPL27_SEAS_UPenn_Internet_Archive_01192000.pdf	555784 17edc7aa101c7276d782ef93c138c99b6454d170	no	4
<b>Warnings:</b>					
<b>Information:</b>					
30	Non Patent Literature	NPL28_XMill_Internet_Archive_03102000.pdf	596277 a06ed58c636f2802008bad1ec56d80d90ba6daa7c	no	12
<b>Warnings:</b>					
<b>Information:</b>					
31	Non Patent Literature	NPL29_XMill_Internet_Archive_08312000.pdf	103641 7896e5fc136f377348e1250e8a73662d389a88ea	no	2
<b>Warnings:</b>					
<b>Information:</b>					
32	Non Patent Literature	NPL30_XMill_Internet_Archive_09252000.pdf	31732 0b5810b62e532fc754685c46daf4e4088696aa94	no	1
<b>Warnings:</b>					
<b>Information:</b>					
33	Non Patent Literature	NPL31_Liefke_2000.pdf	2263308 05cff9351aed6913c1d9c2f1300adcb9bf6f3262	no	26

<b>Warnings:</b>					
<b>Information:</b>					
34	Non Patent Literature	NPL32_XMill_UM_1999.pdf	48426 938a9dad6778c340352472fa5a5232831c32ab9	no	16
<b>Warnings:</b>					
<b>Information:</b>					
35	Fee Worksheet (SB06)	fee-info.pdf	30303 1d7624e312e72b8baa49b5e7cf6cd43f45d2d89	no	2
<b>Warnings:</b>					
<b>Information:</b>					
<b>Total Files Size (in bytes):</b>				86593796	
<p><b>This Acknowledgement Receipt evidences receipt on the noted date by the USPTO of the indicated documents, characterized by the applicant, and including page counts, where applicable. It serves as evidence of receipt similar to a Post Card, as described in MPEP 503.</b></p> <p><b><u>New Applications Under 35 U.S.C. 111</u></b>  <b>If a new application is being filed and the application includes the necessary components for a filing date (see 37 CFR 1.53(b)-(d) and MPEP 506), a Filing Receipt (37 CFR 1.54) will be issued in due course and the date shown on this Acknowledgement Receipt will establish the filing date of the application.</b></p> <p><b><u>National Stage of an International Application under 35 U.S.C. 371</u></b>  <b>If a timely submission to enter the national stage of an international application is compliant with the conditions of 35 U.S.C. 371 and other applicable requirements a Form PCT/DO/EO/903 indicating acceptance of the application as a national stage submission under 35 U.S.C. 371 will be issued in addition to the Filing Receipt, in due course.</b></p> <p><b><u>New International Application Filed with the USPTO as a Receiving Office</u></b>  <b>If a new international application is being filed and the international application includes the necessary components for an international filing date (see PCT Article 11 and MPEP 1810), a Notification of the International Application Number and of the International Filing Date (Form PCT/RO/105) will be issued in due course, subject to prescriptions concerning national security, and the date shown on this Acknowledgement Receipt will establish the international filing date of the application.</b></p>					

MICHAEL V. MESSINGER  
DIRECTOR  
(202) 772-8667  
MIKEM@SKGF.COM



February 1, 2016

Commissioner for Patents  
PO Box 1450  
Alexandria, VA 22313-1450

**Confirmation No. 3403**  
**Art Unit 2634**  
**Attn: Mail Stop Amendment**

Re: U.S. Utility Patent Application  
Application No. 14/876,276; Filing Date: October 6, 2015  
For: **Video Data Compression Systems**  
Inventors: FALLON *et al.*  
Our Ref: 3421.005000C

Commissioner:

Transmitted herewith for appropriate action are the following documents:

1. Online Credit Card Payment Authorization in the amount of \$180.00 in payment of the fee under 37 C.F.R. § 1.17(p);
2. Third Supplemental Information Disclosure Statement;
3. Form PTO/SB/08a (1 sheet) listing 18 documents (**US1-US17** and **FP1**);
4. Form PTO/SB/08b (4 sheets) listing 32 documents (**NPL1-NPL32**); and
5. Copies of cited documents (**FP1** and **NPL1-NPL32**).

***The above-listed documents are filed electronically through EFS-Web.***

In the event that extensions of time are necessary to prevent abandonment of this patent application, then such extensions of time are hereby petitioned.

Fee payment is provided through online credit card payment. The U.S. Patent and Trademark Office is hereby authorized to charge any fee deficiency, or credit any overpayment, to our Deposit Account No. 19-0036.

Respectfully submitted,

STERNE, KESSLER, GOLDSTEIN & FOX P.L.L.C.

A handwritten signature in black ink, appearing to read 'Michael V. Messinger', written over a faint, larger signature.

Michael V. Messinger  
Attorney for Applicant  
Registration No. 37,575

MVM/JXR/wcf  
Enclosures

2763247\_1.DOCX

IN THE UNITED STATES PATENT AND TRADEMARK OFFICE

Inventors: FALLON *et al.*

Applicant: Realtime Data, LLC

Application No.: 14/876,276

Filing Date: October 6, 2015

Title: **Video Data Compression Systems**

Confirmation No.: 3403

Art Unit: 2634

Examiner: BOCURE, TESFALDET

Atty. Docket: 3421.005000C

**Third Supplemental Information Disclosure Statement**

*Mail Stop Amendment*

Commissioner for Patents  
PO Box 1450  
Alexandria, VA 22313-1450

Commissioner:

Notice of Prior and Concurrent Proceedings

Applicant hereby calls to the attention of the Patent and Trademark Office the following reexamination proceedings involving patents that are commonly-assigned with the patent in the above-identified patent application:

<b>Proceeding</b>	<b>Status</b>
Inter Partes Reexamination of U.S. Patent No. 6,604,158 (Control No. 95/000,486)	Inter Partes Reexamination Certificate issued 10/10/2012
Inter Partes Reexamination of U.S. Patent No. 7,321,937 (Control No. 95/000,466)	Inter Partes Reexamination Certificate issued 05/15/2012
Inter Partes Reexamination of U.S. Patent No. 6,604,158 (Control No. 95/000,453)	Terminated
Ex Parte Reexamination of U.S. Patent No. 6,601,104 (Control No. 90/009,428)	Ex Parte Reexamination Certificate issued 02/28/2012
Inter Partes Reexamination of U.S. Patent No. 7,378,992 (Control No. 95/000,478)	Inter Partes Reexamination Certificate issued 10/04/2012
Inter Partes Reexamination of U.S. Patent No. 6,624,761 (Control No. 95/000,464)	Inter Partes Reexamination Certificate issued 06/12/2012
Inter Partes Reexamination of U.S. Patent No. 7,161,506 (Control No. 95/000,479)	Inter Partes Reexamination Certificate issued 05/22/2012

<b>Proceeding</b>	<b>Status</b>
Inter Partes Reexamination of U.S. Patent No. 7,714,747 (Control No. 95/001,517)	Appeal to the Court of Appeals for the Federal Circuit dismissed 6/4/2015
Inter Partes Reexamination of U.S. Patent No. 7,417,568 (Control No. 95/001,533)	Decision on Appeal mailed 10/29/2015
Inter Partes Reexamination of U.S. Patent No. 7,777,651 (Control No. 95/001,581)	Decision on Appeal mailed 10/29/2015
Inter Partes Reexamination of U.S. Patent No. 7,400,274 (Control No. 95/001,544)	Decision on Appeal mailed 10/29/2015

Applicant hereby calls to the attention of the Patent and Trademark Office the following reexamination proceedings filed by Cellco Partnership d/b/a Verizon Wireless, involving patents that are commonly-assigned with the patent in the above-identified patent application:

<b>Proceeding</b>	<b>Status</b>
Inter Partes Reexamination of U.S. Patent No. 7,321,937 (Control No. 95/001,922)	Inter Partes Reexamination Certificate issued 12/05/2013
Inter Partes Reexamination of U.S. Patent No. 6,604,158 (Control No. 95/001,923)	Inter Partes Reexamination Certificate issued 04/17/2015
Inter Partes Reexamination of U.S. Patent No. 7,352,300 (Control No. 95/001,924)	Inter Partes Reexamination Certificate issued 08/04/2014
Inter Partes Reexamination of U.S. Patent No. 7,395,345 (Control No. 95/001,925)	Inter Partes Reexamination Certificate issued 11/03/2014
Inter Partes Reexamination of U.S. Patent No. 7,161,506 (Control No. 95/001,926)	Inter Partes Reexamination Certificate issued 01/08/2014
Inter Partes Reexamination of U.S. Patent No. 7,415,530 (Control No. 95/001,927)	Inter Partes Reexamination Certificate issued 08/16/2013
Inter Partes Reexamination of U.S. Patent No. 7,378,992 (Control No. 95/001,928)	Inter Partes Reexamination Certificate issued 01/08/2014

Applicant invites the Examiner to review the Requests for Reexamination, issued Office Actions, replies, and any other papers in the above-identified reexamination proceedings. If the Examiner is unable to obtain copies of papers in any reexamination proceeding, copies can be

Atty. Dkt. No. 3421.005000C

provided to the Examiner upon request. Those documents which may be material that are not already of record in this patent application are listed on the accompanying Form PTO/SB/08.

Applicant hereby calls to the attention of the Patent and Trademark Office the following *inter partes* review proceedings involving patents that are commonly-assigned with the patent in the above-identified patent application:

<b>Proceeding</b>	<b>Patent</b>	<b>Status</b>
<i>Oracle America, Inc. v. Realtime Data, LLC</i> , IPR2016-00373	7,378,992	Petition filed December 22, 2015
<i>Oracle America, Inc. v. Realtime Data, LLC</i> , IPR2016-00374	8,643,513	Petition filed December 22, 2015
<i>Oracle America, Inc. v. Realtime Data, LLC</i> , IPR2016-00375	7,415,530	Petition filed December 28, 2015
<i>Oracle America, Inc. v. Realtime Data, LLC</i> , IPR2016-00376	7,415,530	Petition filed December 28, 2015
<i>Oracle America, Inc. v. Realtime Data, LLC</i> , IPR2016-00377	9,116,908	Petition filed December 28, 2015

Applicant invites the Examiner to review the petitions for *inter partes* review and any other papers in the above-identified *inter partes* review proceedings. If the Examiner is unable to obtain copies of papers in any *inter partes* review proceeding, copies can be provided to the Examiner upon request. Those documents which may be material that are not already of record in this patent application are listed on the accompanying Form PTO/SB/08.

Notice of Related Litigation

Applicant notifies the Patent and Trademark Office of the following litigation involving U.S. Patents commonly-owned with the current patent application, the subject matter of which may be related to the present patent application:

Atty. Dkt. No. 3421.005000C

No.	Case	Status
1	<i>Realtime Data LLC d/b/a IXO v. Packeteer, Inc. et al.</i> , No. 6:08-cv-00144-LED (E.D. Texas)	Dismissed

Applicant also notifies the Patent and Trademark Office of the following additional litigation involving U.S. Patents commonly-owned with the current patent application, the subject matter of which may be related to the present patent application:

No.	Case	Status
2	<i>Realtime Data LLC d/b/a IXO v. Thomson Reuters Corporation et al.</i> No. 1:11-cv-06698-RJH (S.D. New York) (transferred from E.D. Texas; 6:09-cv-00333-LED)	Case Terminated 11/9/2012; Opinion of the Court of Appeals for the Federal Circuit received 01/27/2014
3	<i>Realtime Data LLC d/b/a IXO v. Morgan Stanley et al.</i> , No. 1:11-cv-06696-RJH (S.D. New York) (transferred from E.D. Texas; 6:09-cv-00326-LED)	Case Terminated 11/9/2012; Opinion of the Court of Appeals for the Federal Circuit received 01/27/2014
4	<i>Realtime Data LLC d/b/a IXO v. CME Group Inc., et al.</i> , No. 1:11-cv-06697-RJH (S.D. New York) (transferred from E.D. Texas; No. 6:09-cv-00327-LED)	Case Terminated 11/9/2012; Opinion of the Court of Appeals for the Federal Circuit received 01/27/2014
5	<i>Chicago Board Options Exchange, Inc., v. Realtime Data LLC d/b/a IXO</i> , No. 09-cv-4486 (N.D. Ill.)	Dismissed
6	<i>Thomson Reuters Corporation v. Realtime Data, LLC d/b/a IXO</i> , No. 1:09-cv-07868-RMB (S.D.N.Y)	Consolidated with Case No. 2
7	<i>Realtime Data, LLC d/b/a IXO v. CME Group Inc., et al. (II)</i> , No. 6:10-cv-246 (E.D. Texas)	Consolidated with Case No. 4
8	<i>Realtime Data LLC d/b/a IXO v. Thomson Reuters Corporation et al. (II)</i> , No. 6:10-cv-247 (E.D. Texas)	Consolidated with Case No. 2
9	<i>Realtime Data, LLC d/b/a IXO v. Morgan Stanley, et al. (II)</i> , No. 6:10-cv-248 (E.D. Texas)	Consolidated with Case No. 3
10	<i>Realtime Data, LLC d/b/a IXO v. MetroPCS Texas, LLC et al.</i> , No. 6:10-cv-00493 (E.D. Texas)	Appeal Terminated

11	<i>Realtime Data, LLC d/b/a IXO v. Microsoft Corporation, et al.</i> , No. 4:14-cv-00827 (E.D. Texas)	Dismissed May 1, 2015
12	<i>Realtime Data, LLC d/b/a IXO v. Actian Corporation, et al.</i> , No. 6:15-cv-00463 (E.D. Texas)	Amended Complaints for Patent Infringement filed September 14, 2015
13	<i>Realtime Data, LLC d/b/a IXO v. Dropbox, Inc.</i> , No. 6:15-cv-00465 (E.D. Texas)	Transferred to the Northern District of California, January 16, 2016
14	<i>Realtime Data, LLC d/b/a IXO v. Echostar Corporation, et al.</i> , No. 6:15-cv-00466 (E.D. Texas)	Consolidated with Case No. 12
15	<i>Realtime Data, LLC d/b/a IXO v. Riverbed Technology, Inc., et al.</i> , No. 6:15-cv-00468 (E.D. Texas)	Consolidated with Case No. 12
16	<i>Realtime Data, LLC d/b/a IXO v. BMC Software, Inc.</i> , No. 6:15-cv-00464 (E.D. Texas)	Terminated October 5, 2015
17	<i>Realtime Data, LLC d/b/a IXO v. Oracle America, Inc., et al.</i> , No. 6:15-cv-00467 (E.D. Texas)	Consolidated with Case No. 12
18	<i>Realtime Data, LLC d/b/a IXO v. SAP America, Inc., et al.</i> , No. 6:15-cv-00469 (E.D. Texas)	Consolidated with Case No. 12
19	<i>Realtime Data, LLC d/b/a IXO v. Teradata Corporation, et al.</i> , No. 6:15-cv-00470 (E.D. Texas)	Transferred to the Northern District of California, January 19, 2016
20	<i>Realtime Data, LLC d/b/a IXO v. Apple, Inc.</i> , No. 6:15-cv-00885 (E.D. Texas)	Complaint filed October 6, 2015

Information Disclosure Statement

Listed on accompanying IDS Forms PTO/SB/08a equivalent and PTO/SB/08b equivalent are documents that may be considered material to the patentability of this application as defined in 37 C.F.R. §1.56, and in compliance with the duty of disclosure requirements of 37 C.F.R. §§ 1.97 and 1.98.

Atty. Dkt. No. 3421.005000C



Applicant has listed publication dates on the attached IDS Forms based on information presently available to the undersigned. However, the listed publication dates should not be construed as an admission that the information was actually published on the date indicated.

Applicant reserves the right to establish the patentability of the claimed invention over any of the information provided herewith, and/or to prove that this information may not be prior art, and/or to prove that this information may not be enabling for the teachings purportedly offered.

This statement should not be construed as a representation that a search has been made, or that information more material to the examination of the present patent application does not exist. The Examiner is specifically requested not to rely solely on the material submitted herewith.

Filing under 37 C.F.R. § 1.97(c). This Information Disclosure Statement is being filed more than three months after the U.S. filing date AND after the mailing date of the first Office Action on the merits, but before the mailing date of a Final Rejection, or Notice of Allowance, or an action that otherwise closes prosecution in the application. The required fee is provided through online credit card payment authorization in the amount of \$180.00 in payment of the fee under 37 C.F.R. § 1.17(p).

Copies of documents **FP1** and **NPL1-NPL32** are submitted. However, in accordance with 37 C.F.R. § 1.98(a)(2)(ii), no copies of the U.S. patents and patent application publications cited as documents **US1-US17** on the attached IDS Forms are submitted.

It is expected that the examiner will review the prosecution and cited art in the parent application nos. 14/733,565, filed June 8, 2015 (now pending); 14/577,286, filed December 19, 2014 (now abandoned); 14/134,933, filed December 19, 2013 (now U.S. Patent No. 8,929,442);

Atty. Dkt. No. 3421.005000C

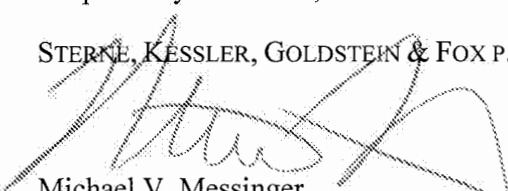
14/033,245, filed September 20, 2013 (now U.S. Patent No. 8,934,535); 13/154,239, filed June 6, 2011 (now U.S. Patent No. 8,553,759); 12/123,081, filed May 19, 2008 (now U.S. Patent No. 8,073,047); and 10/076,013, filed February 13, 2002 (now U.S. Patent No. 7,386,046), in accordance with MPEP 2001.06(b), and indicate in the next communication from the office that the art cited in the earlier prosecution history has been reviewed in connection with the present application.

It is respectfully requested that the Examiner initial and return a copy of the enclosed IDS Forms, and indicate in the official file wrapper of this patent application that the documents have been considered.

The U.S. Patent and Trademark Office is hereby authorized to charge any fee deficiency, or credit any overpayment, to our Deposit Account No. 19-0036.

Respectfully submitted,

STERNE, KESSLER, GOLDSTEIN & FOX P.L.L.C.

  
Michael V. Messinger  
Attorney for Applicant  
Registration No. 37,575

Date:

February 1, 2016

1100 New York Avenue, N.W.  
Washington, D.C. 20005-3934  
(202) 371-2600

2763240\_1.DOCX

Atty. Dkt. No. 3421.005000C



Substitute for form 1449/PTO		<b>Complete if Known</b>	
<b>FOURTH SUPPLEMENTAL INFORMATION DISCLOSURE STATEMENT BY APPLICANT</b> <i>(Use as many sheets as necessary)</i>		Application Number	14/876,276
		Filing Date	October 6, 2015
		First Named Inventor	James J. FALLON
		Art Unit	2634
		Examiner Name	BOCURE, TEFALDET
		Attorney Docket Number	3421.005000C
Sheet	1	of	14

NON PATENT LITERATURE DOCUMENTS			
Examiner Initials*	Cite No. <sup>1</sup>	Include name of the author (in CAPITAL LETTERS), title of the article (when appropriate), title of the item (book, magazine, journal, serial, symposium, catalog, etc.), date, page(s), volume-issue number(s), publisher, city and/or country where published	T <sup>2</sup>
	NPL1	Second Amended Complaint for Patent Infringement Against Riverbed Technology, Inc. and Dell, Inc., filed in Realtime Data LLC d/b/a IXO v. Actian Corporation, et al., Case No. 6:15-cv-00463-RWS-JDL (E.D. Texas), filed February 2, 2016; 37 pages.	
	NPL2	Defendant Dropbox's Answer to Plaintiff Realtime Data LLC d/b/a IXO's Amended Complaint, filed in Realtime Data LLC d/b/a IXO v. Actian Corporation, et al., Case No. 6:15-cv-00463-RWS-JDL (E.D. Texas), filed February 4, 2016; 10 pages.	
	NPL3	Defendants Echostar Corporation's and Hughes Network Systems, LLC's Answer, Affirmative Defenses, and Counterclaims to Plaintiff Realtime Data LLC d/b/a IXO's Amended Complaint, filed in Realtime Data LLC d/b/a IXO v. Actian Corporation, et al., Case No. 6:15-cv-00463-RWS-JDL (E.D. Texas), filed February 4, 2016; 23 pages.	
	NPL4	Defendants SAP America Inc. and SyBase, Inc.'s Answer, Affirmative Defenses, and Counterclaims to Plaintiff's Second Amended Complaint, filed in Realtime Data LLC d/b/a IXO v. Actian Corporation, et al., Case No. 6:15-cv-00463-RWS-JDL (E.D. Texas), filed February 4, 2016; 35 pages.	
	NPL5	Dell Inc.'s Answer, Defenses, and Counterclaims to Plaintiff's Amended Complaint, filed in Realtime Data LLC d/b/a IXO v. Actian Corporation, et al., Case No. 6:15-cv-00463-RWS-JDL (E.D. Texas), filed February 4, 2016; 28 pages.	
	NPL6	Standard Function Library (SFL) Code, Version 1.4, written March 29, 1993, revised January 2, 1997; 190 pages.	
	NPL7	Standard Function Library Documentation, written June 4, 1997, revised November 17, 1997; 1,102 pages. (Submitted in 6 parts.)	
	NPL8	Defendants Oracle America, Inc., Hewlett-Packard Company, and HP Enterprise Services, LLC's Invalidity Contentions, submitted in Realtime Data, LLC d/b/a IXO v. Actian Corporation, et al., Case No. 6:15-cv-00463-RWS-JDL (E.D. Texas), served December 4, 2015; 62 pages.	
	NPL9	Non-Confidential Exhibits A3-A4 to Defendants Oracle America, Inc., Hewlett-Packard Company, and HP Enterprise Services, LLC's Invalidity Contentions, submitted in Realtime Data, LLC d/b/a IXO v. Actian Corporation, et al., Case No. 6:15-cv-00463-RWS-JDL (E.D. Texas), served December 4, 2015; 296 pages.	
	NPL10	Non-Confidential Exhibits B3-B4 to Defendants Oracle America, Inc., Hewlett-Packard Company, and HP Enterprise Services, LLC's Invalidity Contentions, submitted in Realtime Data, LLC d/b/a IXO v. Actian Corporation, et al., Case No. 6:15-cv-00463-RWS-JDL (E.D. Texas), served December 4, 2015; 1,179 pages.	
Examiner Signature		Date Considered	

\*EXAMINER: Initial if reference considered, whether or not citation is in conformance with MPEP 609. Draw line through citation if not in conformance and not considered. Include copy of this form with next communication to applicant.

<sup>1</sup> Applicant's unique citation designation number (optional). <sup>2</sup> Applicant is to place a check mark here if English language Translation is attached.

Substitute for form 1449/PTO		<b>Complete if Known</b>	
<b>FOURTH SUPPLEMENTAL INFORMATION DISCLOSURE STATEMENT BY APPLICANT</b> <i>(Use as many sheets as necessary)</i>		Application Number	14/876,276
		Filing Date	October 6, 2015
		First Named Inventor	James J. FALLON
		Art Unit	2634
		Examiner Name	BOCURE, TESFALDET
		Attorney Docket Number	3421.005000C
Sheet	2	of	14

NON PATENT LITERATURE DOCUMENTS			
Examiner Initials*	Cite No. <sup>1</sup>	Include name of the author (in CAPITAL LETTERS), title of the article (when appropriate), title of the item (book, magazine, journal, serial, symposium, catalog, etc.), date, page(s), volume number, publisher, city and/or country where published	T <sup>2</sup>
	NPL11	Non-Confidential Exhibits C4-C7 and C9 to Defendants Oracle America, Inc., Hewlett-Packard Company, and HP Enterprise Services, LLC's Invalidation Contentions, submitted in Realtime Data, LLC d/b/a IXO v. Actian Corporation, et al., Case No. 6:15-cv-00463-RWS-JDL (E.D. Texas), served December 4, 2015; 3,029 pages.	
	NPL12	Non-Confidential Exhibits D4-D7 and D9 to Defendants Oracle America, Inc., Hewlett-Packard Company, and HP Enterprise Services, LLC's Invalidation Contentions, submitted in Realtime Data, LLC d/b/a IXO v. Actian Corporation, et al., Case No. 6:15-cv-00463-RWS-JDL (E.D. Texas), served December 4, 2015; 3,125 pages.	
	NPL13	Non-Confidential Exhibits E1-E4 to Defendants Oracle America, Inc., Hewlett-Packard Company, and HP Enterprise Services, LLC's Invalidation Contentions, submitted in Realtime Data, LLC d/b/a IXO v. Actian Corporation, et al., Case No. 6:15-cv-00463-RWS-JDL (E.D. Texas), served December 4, 2015; 1,657 pages.	
	NPL14	"Adaptive Lossless Data Compression Algorithm," ECMA Standard ECMA-222, June 1995; 20 pages.	
	NPL15	"ALDC1-40S Adaptive Lossless Data Compression," IBM Microelectronics Data Compression Technologies, May 1994; 2 pages.	
	NPL16	AMIR, ET AL., "An Application Level Video Gateway," ACM Multimedia, San Francisco, November 1995; 11 pages.	
	NPL17	ANDREWS, ET AL., "A Mean-Removed Variation of Weighted Universal Vector Quantization for Image Coding," IEEE Data Compression Conference, 1993; pp. 302-309.	
	NPL18	AX.25 Link Access Protocol for Amateur Packet Radio, Version 2.2, Tuscon Amateur Packet Radio Corporation, Revision: July 1998; 143 pages.	
	NPL19	BAKER, ET AL., "Lossless Data Compression for Short Duration 3D Frames in Positron Emission Tomography," IEEE Nuclear Science Symposium and Medical Imaging Conference, 1993; pp. 1831-1834.	
	NPL20	BASSIOUNI, ET AL., "A Scheme for Data Compression in Supercomputers," IEEE Supercomputing '88, 1988; pp. 272-278.	
Examiner Signature		Date Considered	

\*EXAMINER: Initial if reference considered, whether or not citation is in conformance with MPEP 609. Draw line through citation if not in conformance and not considered. Include copy of this form with next communication to applicant.

<sup>1</sup> Applicant's unique citation designation number (optional). <sup>2</sup> Applicant is to place a check mark here if English language Translation is attached.

Substitute for form 1449/PTO				<b>Complete if Known</b>	
<b>FOURTH SUPPLEMENTAL INFORMATION DISCLOSURE STATEMENT BY APPLICANT</b> <i>(Use as many sheets as necessary)</i>				Application Number	14/876,276
				Filing Date	October 6, 2015
				First Named Inventor	James J. FALLON
				Art Unit	2634
				Examiner Name	BOCURE, TESFALDET
Sheet	3	of	14	Attorney Docket Number	3421.005000C

NON PATENT LITERATURE DOCUMENTS			
Examiner Initials*	Cite No. <sup>1</sup>	Include name of the author (in CAPITAL LETTERS), title of the article (when appropriate), title of the item (book, magazine, journal, serial, symposium, catalog, etc.), date, page(s), volume number, publisher, city and/or country where published	T <sup>2</sup>
	NPL21	BRUCKMANN, ET AL., "Selective Medical Image Compression Using Wavelet Techniques," Journal of Computing and Information Technology, Vol. 6, No. 2 (1998); 23 pages.	
	NPL22	CHENG, ET AL., "A fast, highly reliable data compression chip and algorithm for storage systems," IBM Journal of Research and Development, Vol. 40, No. 6, November 1996; pp. 603-613.	
	NPL23	ZHANG, ET AL., "Content-based video retrieval and compression: a unified solution," IEEE Proceedings of the International Conference on Image Processing, October 1997; pp. 13-16.	
	NPL24	CRAFT, D., "A fast hardware data compression algorithm and some algorithmic extensions," IBM Journal of Research and Development, Vol. 42, No. 6, November 1998; pp. 733-745.	
	NPL25	SATTLER, M., Internet TV with CU-SeeMe, Indianapolis, IN: sams.net, 1995; 172 pages.	
	NPL26	DANSKIN, J., "Compressing The X Graphics Protocol," Dissertation, Princeton University Department of Computer Science, January 1995; 147 pages.	
	NPL27	FOX, ET AL., "Adapting to Network and Client Variability via On-Demand Dynamic Distillation," Proceedings of the Seventh International Conference on Architectural Support for Programming Languages and Operating Systems, 1996; pp. 160-170.	
	NPL28	FOX, ET AL., "Adapting to Network and Client Variability Using Infrastructural Proxies: Lessons and Perspectives," Abstract, IEEE Personal Communications, Vol. 5, No. 4, August 1998; 2 pages.	
	NPL29	BOTTOU, ET AL., "High Quality Document Image Compression with DjVu," Journal of Electronic Imaging, Vol. 7, No. 3, 1998; pp. 410-425.	
	NPL30	HOWARD, ET AL., "Parallel Lossless Image Compression Using Huffman and Arithmetic Coding," IEEE Data Compression Conference, March 1992; pp. 299-308.	

Examiner Signature		Date Considered	
-----------------------	--	--------------------	--

\*EXAMINER: Initial if reference considered, whether or not citation is in conformance with MPEP 609. Draw line through citation if not in conformance and not considered. Include copy of this form with next communication to applicant.

<sup>1</sup> Applicant's unique citation designation number (optional). <sup>2</sup> Applicant is to place a check mark here if English language Translation is attached.

Substitute for form 1449/PTO		<b>Complete if Known</b>	
<b>FOURTH SUPPLEMENTAL INFORMATION DISCLOSURE STATEMENT BY APPLICANT</b> <i>(Use as many sheets as necessary)</i>		Application Number	14/876,276
		Filing Date	October 6, 2015
		First Named Inventor	James J. FALLON
		Art Unit	2634
		Examiner Name	BOCURE, TESFALDET
		Attorney Docket Number	3421.005000C
Sheet	4	of	14

NON PATENT LITERATURE DOCUMENTS			
Examiner Initials*	Cite No. <sup>1</sup>	Include name of the author (in CAPITAL LETTERS), title of the article (when appropriate), title of the item (book, magazine, journal, serial, symposium, catalog, etc.), date, page(s), volume number, publisher, city and/or country where published	T <sup>2</sup>
	NPL31	"Hewlett-Packard Journal," Hewlett-Packard Corporation, June 1989; 84 pages.	
	NPL32	HSU, ET AL., "Automatic Synthesis of Compression Techniques for Heterogeneous Files," Software - Practice and Experience, Vol. 25, No. 10, October 1995; pp. 1097-1116.	
	NPL33	"Guide to Sharing and Partitioning IBM Tape Library Dataservers," IBM International Technical Support Organization, San Jose Center, November 1996; 276 pages. (Submitted in 2 parts.)	
	NPL34	"Add-On Options for the XpressFiles," Intelligent Compression Technologies, 1998, accessible at < <a href="http://web.archive.org/web/19980518053418/ictcompress.com/options_X.html">http://web.archive.org/web/19980518053418/ictcompress.com/options_X.html</a> >; 2 pages.	
	NPL35	"Introducing XpressFiles," Intelligent Compression Technologies, 1998, accessible at < <a href="http://web.archive.org/web/19980518053310/ictcompress.com/xpressfiles.html">http://web.archive.org/web/19980518053310/ictcompress.com/xpressfiles.html</a> >; 1 page.	
	NPL36	"The Technology Behind XpressFiles," Intelligent Compression Technologies, 1998, accessible at < <a href="http://web.archive.org/web/19980518053634/ictcompress.com/technical_X.html">http://web.archive.org/web/19980518053634/ictcompress.com/technical_X.html</a> >; 1 page.	
	NPL37	XpressFiles White Paper, Intelligent Compression Technologies, 1999; 3 pages.	
	NPL38	"XML-Xpress Product Overview," Intelligent Compression Technologies, 2001, accessible at < <a href="http://web.archive.org/web/20020818002535/www.ictcompress.com/products_xmlxpress.html">http://web.archive.org/web/20020818002535/www.ictcompress.com/products_xmlxpress.html</a> >; 2 pages.	
	NPL39	"ICT's XML-Xpress," Intelligent Compression Technologies, December 2000; 6 pages.	
	NPL40	LARMOUTH, J., "ASN. 1 Complete," Open Systems Solutions, 1999; 387 pages. (Submitted in 4 parts.)	
Examiner Signature		Date Considered	

\*EXAMINER: Initial if reference considered, whether or not citation is in conformance with MPEP 609. Draw line through citation if not in conformance and not considered. Include copy of this form with next communication to applicant.

<sup>1</sup> Applicant's unique citation designation number (optional). <sup>2</sup> Applicant is to place a check mark here if English language Translation is attached.

Substitute for form 1449/PTO		<b>Complete if Known</b>	
<b>FOURTH SUPPLEMENTAL INFORMATION DISCLOSURE STATEMENT BY APPLICANT</b> <i>(Use as many sheets as necessary)</i>		Application Number	14/876,276
		Filing Date	October 6, 2015
		First Named Inventor	James J. FALLON
		Art Unit	2634
		Examiner Name	BOCURE, TESFALDET
		Attorney Docket Number	3421.005000C
		Sheet	5 of 14

NON PATENT LITERATURE DOCUMENTS			
Examiner Initials*	Cite No. <sup>1</sup>	Include name of the author (in CAPITAL LETTERS), title of the article (when appropriate), title of the item (book, magazine, journal, serial, symposium, catalog, etc.), date, page(s), volume number, publisher, city and/or country where published	T <sup>2</sup>
	NPL41	"Magstar and IBM 3590 High Performance Tape Subsystem Technical Guide," IBM International Technical Support Organization, San Jose Center, November 1996; 287 pages. (Submitted in 2 parts.)	
	NPL42	McGREGOR, ET AL., "Performance Impact of Data Compression on Virtual Private Network Transactions," IEEE Proceedings of the 25th Annual Conference on Local Computer Networks, 2000; 11 pages.	
	NPL43	SUMMERS, B., "Official Microsoft NetMeeting Book," Redmond, WA: Microsoft Press, 1998; 374 pages. (Submitted in 5 parts.)	
	NPL44	BRITTON, ET AL., Discover Desktop Conferencing with NetMeeting 2.0, Foster City, CA: IDG Books Worldwide, Inc., 1998; 304 pages. (Submitted in 4 parts.)	
	NPL45	RANGANATHAN, N., "High-Speed VLSI Designs for Lempel-Ziv-Based Data Compression," IEEE Transactions on Circuits and Systems - II: Analog and Digital Signal Processing, Vol. 40, No. 2, February 1993; pp. 96-106.	
	NPL46	User's Guide, Sidewinder 50 AIT-1 Tape Drive, Seagate Technology, Inc., 1997; 19 pages.	
	NPL47	PROSISE, J., "Understanding Data Compression," PC Magazine, May 25, 1993; pp. 305-308.	
	NPL48	WELCH, T., Source Code, University of California, 1985; 23 pages.	
	NPL49	ABALI, ET AL., "Memory Expansion Technology (MXT): Software Support and Performance," IBM Journalist of Research and Development, Vol. 45, No. 2, March 2001; pp. 287-301.	
	NPL50	ANDERSON, ET AL., "Codec Squeezes Color Teleconferencing Through Digital Telephone Lines," Electronics, January 26, 1984; pp. 113-115.	
Examiner Signature		Date Considered	

\*EXAMINER: Initial if reference considered, whether or not citation is in conformance with MPEP 609. Draw line through citation if not in conformance and not considered. Include copy of this form with next communication to applicant.

<sup>1</sup> Applicant's unique citation designation number (optional). <sup>2</sup> Applicant is to place a check mark here if English language Translation is attached.



Substitute for form 1449/PTO		<b>Complete if Known</b>	
<b>FOURTH SUPPLEMENTAL INFORMATION DISCLOSURE STATEMENT BY APPLICANT</b> <i>(Use as many sheets as necessary)</i>		Application Number	14/876,276
		Filing Date	October 6, 2015
		First Named Inventor	James J. FALLON
		Art Unit	2634
		Examiner Name	BOCURE, TESFALDET
		Attorney Docket Number	3421.005000C
Sheet	6	of	14

NON PATENT LITERATURE DOCUMENTS			
Examiner Initials*	Cite No. <sup>1</sup>	Include name of the author (in CAPITAL LETTERS), title of the article (when appropriate), title of the item (book, magazine, journal, serial, symposium, catalog, etc.), date, page(s), volume number, publisher, city and/or country where published	T <sup>2</sup>
	NPL51	COENE, ET AL., "A Fast Route For Application of Rate-Distortion Optimal Quantization in an MPEG Encoder," IEEE Proceedings of the International Conference on Image Processing, 1996; pp. 825-828.	
	NPL52	FRANASZEK, ET AL., "Algorithms and Data Structures for Compressed-Memory Machines," IBM Journal of Research and Development, Vol. 45, No. 2, March 2001; pp. 245-258.	
	NPL53	FRANASZEK, ET AL., "On Internal Organization in Compressed Random-Access Memories," IBM Journal of Research and Development, Vol. 45, No. 2, March 2001; pp. 259-270.	
	NPL54	IBM Technical Disclosure Bulletin, Vol. 38, No. 2, February 1995; 3 pages.	
	NPL55	"IBM Boosts Your Memory," Geek.com, accessible at < <a href="http://www.geek.com/ibm-boosts-your-memory/">http://www.geek.com/ibm-boosts-your-memory/</a> >, June 26, 2000; 3 pages.	
	NPL56	"IBM Research Breakthrough Doubles Computer Memory Capacity," IBM Press Release, June 26, 2000; 3 pages.	
	NPL57	IBM Technical Disclosure Bulletin, Vol. 37, No. 2B, February 1994; 3 pages.	
	NPL58	International Search Reports directed to International Patent Application Nos. PCT/US01/03711 and PCT/US01/03712, January 28, 2001 and May 10, 2002; 9 pages.	
	NPL59	MURASHITA, ET AL., "High-Speed Statistical Compression Using Self-Organized Rules and Predetermined Code Tables," IEEE Proceedings of Data Compression Conference, 1996; p. 449.	
	NPL60	RICE, ET AL., "Lossless Coding Standards for Space Data Systems," IEEE Conference Record of the Thirtieth Asilomar Conference on Signals, Systems and Computers, 1996; pp. 577-585.	

Examiner Signature		Date Considered	
-----------------------	--	--------------------	--

\*EXAMINER: Initial if reference considered, whether or not citation is in conformance with MPEP 609. Draw line through citation if not in conformance and not considered. Include copy of this form with next communication to applicant.

<sup>1</sup> Applicant's unique citation designation number (optional). <sup>2</sup> Applicant is to place a check mark here if English language Translation is attached.

Substitute for form 1449/PTO		<b>Complete if Known</b>	
<b>FOURTH SUPPLEMENTAL INFORMATION DISCLOSURE STATEMENT BY APPLICANT</b> <i>(Use as many sheets as necessary)</i>		Application Number	14/876,276
		Filing Date	October 6, 2015
		First Named Inventor	James J. FALLON
		Art Unit	2634
		Examiner Name	BOCURE, TESFALDET
		Attorney Docket Number	3421.005000C
Sheet	7	of	14

NON PATENT LITERATURE DOCUMENTS			
Examiner Initials*	Cite No. <sup>1</sup>	Include name of the author (in CAPITAL LETTERS), title of the article (when appropriate), title of the item (book, magazine, journal, serial, symposium, catalog, etc.), date, page(s), volume number, publisher, city and/or country where published	T <sup>2</sup>
	NPL61	RICE, R., "Some Practical Universal Noiseless Coding Techniques," National Aeronautics and Space Administration, JPL Publication 79-22, 1979; 149 pages.	
	NPL62	"ServerWorks To Deliver IBM's Memory eXpansion Technology in Next-Generation Core Logic for Servers," ServerWorks press release, accessible at < <a href="http://www.serverworks.com/news/press/000627.html">http://www.serverworks.com/news/press/000627.html</a> >, June 27, 2000; 1 page.	
	NPL63	SMITH, ET AL., "Memory Expansion Technology (MXT): Competitive Impact," IBM Journal of Research and Development, Vol. 45, No. 2, March 2001; pp. 303-309.	
	NPL64	TREMAINE, ET AL., "IBM Memory Expansion Technology (MXT)," IBM Journal of Research and Development, Vol. 45, No. 2, March 2001; pp. 271-285.	
	NPL65	VENBRUX, ET AL., "A VLSI Chip Set for High-Speed Lossless Data Compression," IEEE Transactions on Circuits and Systems for Video Technology, Vol. 2, No. 4, December 1992; pp. 381-391.	
	NPL66	YEH, P., "The CCSDS Lossless Data Compression Recommendation for Space Applications," Chapter 16, Lossless Compression Handbook, SAYOOD, K., ed., Academic Press, 2003; pp. 311-326.	
	NPL67	MARTIN, J., "HP drive offers data compression," COMPUTERWORLD, May 9, 1988; p. 76.	
	NPL68	MILLMAN, H., "Image and Video Compression," COMPUTERWORLD, January 18, 1999; p. 78.	
	NPL69	"MegaRam Disc Emulator: Revolutionary, Non-rotating, Solid-state Replacement for Fixed and Moving Head Discs," Imperial Technology, Inc., October 1985; 4 pages.	
	NPL70	"MegaRam-PC: Solid-State Disk Emulator For The IBM And IBM Compatible Personal Computers," Imperial Technology, Inc., October 1985; 2 pages.	

Examiner Signature		Date Considered	
-----------------------	--	--------------------	--

\*EXAMINER: Initial if reference considered, whether or not citation is in conformance with MPEP 609. Draw line through citation if not in conformance and not considered. Include copy of this form with next communication to applicant.

<sup>1</sup> Applicant's unique citation designation number (optional). <sup>2</sup> Applicant is to place a check mark here if English language Translation is attached.

Substitute for form 1449/PTO		<b>Complete if Known</b>	
<b>FOURTH SUPPLEMENTAL INFORMATION DISCLOSURE STATEMENT BY APPLICANT</b> <i>(Use as many sheets as necessary)</i>		Application Number	14/876,276
		Filing Date	October 6, 2015
		First Named Inventor	James J. FALLON
		Art Unit	2634
		Examiner Name	BOCURE, TESFALDET
		Attorney Docket Number	3421.005000C
Sheet	8	of	14

NON PATENT LITERATURE DOCUMENTS			
Examiner Initials*	Cite No. <sup>1</sup>	Include name of the author (in CAPITAL LETTERS), title of the article (when appropriate), title of the item (book, magazine, journal, serial, symposium, catalog, etc.), date, page(s), volume number, publisher, city and/or country where published	T <sup>2</sup>
	NPL71	"MegaRam Solid State Disks," Imperial Technology, Inc., accessible via the Internet Archive at < <a href="https://web.archive.org/web/19990501183337/http://imperialtech.com/SolidState.html">https://web.archive.org/web/19990501183337/http://imperialtech.com/SolidState.html</a> >, May 1, 1999; 3 pages.	
	NPL72	"Quantum Rushmore Solid State Disk Drives," Quantum Corporation, accessible via the Internet Archive at < <a href="http://web.archive.org/web/19990508051125/http://www.quantum.com/products/ssd/">http://web.archive.org/web/19990508051125/http://www.quantum.com/products/ssd/</a> >, May 8, 1999; 3 pages.	
	NPL73	"Lucent Opts for Hi/fn Compression and Encryption In Latest Portmaster Products," PR Newswire, May 11, 1999; 2 pages.	
	NPL74	7711 to 7751 Migration Application Note, Hi/fn Network Security Processors, Application Note AN-0002-00, October 1, 1998; 8 pages.	
	NPL75	9705 Network Software Design Guide Application Note, Stac Electronics, Inc., APP-0012 Revision 1.0, May 1993; 30 pages.	
	NPL76	9705/9705A Data Compression Coprocessor Data Sheet, Hi/fn, May 1996; 87 pages.	
	NPL77	9711 to 7711 Migration Application Note, Hi/fn Network Security Processors, Application Note AN-0007-00, October 1, 1998; 7 pages.	
	NPL78	9732AM Data Compression Coprocessor Data Sheet, Hi/fn, PRS-0055 Revision 0.1, May 1999; 58 pages.	
	NPL79	BLELLOCH, G., "Algorithms in the Real World: Lecture Notes (Fall 1997)," Lecture Notes, UC Berkeley, April 23, 1998; 303 pages. (Submitted in 2 parts.)	
	NPL80	LeCUN, ET AL., "DjVu: a Compression Method for Distributing Scanned Documents in Color over the Internet," AT&T Labs-Research, January 1999; 2 pages.	

Examiner Signature	Date Considered
-----------------------	--------------------

\*EXAMINER: Initial if reference considered, whether or not citation is in conformance with MPEP 609. Draw line through citation if not in conformance and not considered. Include copy of this form with next communication to applicant.

<sup>1</sup> Applicant's unique citation designation number (optional). <sup>2</sup> Applicant is to place a check mark here if English language Translation is attached.

Substitute for form 1449/PTO		<b>Complete if Known</b>	
<b>FOURTH SUPPLEMENTAL INFORMATION DISCLOSURE STATEMENT BY APPLICANT</b> <i>(Use as many sheets as necessary)</i>		Application Number	14/876,276
		Filing Date	October 6, 2015
		First Named Inventor	James J. FALLON
		Art Unit	2634
		Examiner Name	BOCURE, TESFALDET
		Attorney Docket Number	3421.005000C
		Sheet	9

NON PATENT LITERATURE DOCUMENTS			
Examiner Initials*	Cite No. <sup>1</sup>	Include name of the author (in CAPITAL LETTERS), title of the article (when appropriate), title of the item (book, magazine, journal, serial, symposium, catalog, etc.), date, page(s), volume number, publisher, city and/or country where published	T <sup>2</sup>
	NPL81	9732A Data Compression Coprocessor Data Sheet, Hi/fn, October 1999; 50 pages.	
	NPL82	7711 Encryption Processor Data Sheet, Hi/fn Network Security Processors, June 1999; 77 pages.	
	NPL83	7751 Encryption Processor Data Sheet, Hi/fn Network Security Processors, June 1999; 84 pages.	
	NPL84	9751 Data Compression Processor Data Sheet, Hi/fn, June 1999; 66 pages.	
	NPL85	"Hi/fn Encryption Products Power Network Alchemy's Revolutionary VPN Products," Business Wire, January 26, 1999; 2 pages.	
	NPL86	"Hi/fn Provides Hardware Encryption for Xedia's New Access Point QPVN Internet Access Platform," Business Wire, October 19, 1998; 2 pages.	
	NPL87	"LZW Data Compression," Dr. Dobb's, October 1, 1989; 14 pages.	
	NPL88	"New Accelerator Chip From Hi/fn to Speed-Up Virtual Private Networks - 'VPNs'," Business Wire, January 26, 1999; 3 pages.	
	NPL89	Programming the 7711 For IPSEC Applications Application Note, Hi/fn Network Security Processors, Application Note AN-0002-00, October 1, 1998; 15 pages.	
	NPL90	FRIEND, R., "IP Payload Compression Using LZS, Request for Comments" The Internet Society, Network Working Group, Hi/fn, Inc., December 1998; 9 pages.	

Examiner Signature		Date Considered	
-----------------------	--	--------------------	--

\*EXAMINER: Initial if reference considered, whether or not citation is in conformance with MPEP 609. Draw line through citation if not in conformance and not considered. Include copy of this form with next communication to applicant.

<sup>1</sup> Applicant's unique citation designation number (optional). <sup>2</sup> Applicant is to place a check mark here if English language Translation is attached.

Substitute for form 1449/PTO		<b>Complete if Known</b>	
<b>FOURTH SUPPLEMENTAL INFORMATION DISCLOSURE STATEMENT BY APPLICANT</b> <i>(Use as many sheets as necessary)</i>		Application Number	14/876,276
		Filing Date	October 6, 2015
		First Named Inventor	James J. FALLON
		Art Unit	2634
		Examiner Name	BOCURE, TEFALDET
		Attorney Docket Number	3421.005000C
Sheet	10	of	14

NON PATENT LITERATURE DOCUMENTS			
Examiner Initials*	Cite No. <sup>1</sup>	Include name of the author (in CAPITAL LETTERS), title of the article (when appropriate), title of the item (book, magazine, journal, serial, symposium, catalog, etc.), date, page(s), volume number, publisher, city and/or country where published	T <sup>2</sup>
	NPL91	Screenshot of hifn.com, accessible via the Internet Archive at < <a href="https://web.archive.org/web/19981212025553/http://www.hifn.com/">https://web.archive.org/web/19981212025553/http://www.hifn.com/</a> >, December 12, 1998; 1 page.	
	NPL92	WIRBEL, L., "Volume shipment for Hi/fn encryption processor," Electronic Engineering Times, Issue 1005, May 4, 1998; 2 pages.	
	NPL93	"Intelligent Compression Technologies: Intelligent Compression Technologies releases XML compressor, XML-Xpress," M2 Presswire, January 30, 2001; 5 pages.	
	NPL94	Form 10 - General Form for Registration of Securities, hi/fn, inc., United States Securities and Exchange Commission, filed December 8, 1998; 387 pages. (Submitted in 3 parts.)	
	NPL95	Form S-3 - Registration Statement Under The Securities Act of 1913, hi/fn, inc., United States Securities and Exchange Commission, filed February 17, 1999; 151 pages.	
	NPL96	HP 7979A/7980A/7980XC Tape Drive User's Guide, Hewlett-Packard Corporation, HP Computer Museum, October 1988; 76 pages.	
	NPL97	7980A Tape Drive - Documentation, HP Computer Museum, accessible at < <a href="http://www.hp-museum.net/exhibit.php?hwdoc=390">http://www.hp-museum.net/exhibit.php?hwdoc=390</a> >, September 22, 2015; 1 page.	
	NPL98	The HP 7980A/7979A 1/2-inch Tape Drives, Hewlett-Packard Product Specifications, June 1, 1987; 2 pages.	
	NPL99	9145A Tape Drive - Documentation, HP Computer Museum, accessible at < <a href="http://www.hp-museum.net/exhibit.php?hwdoc=258">http://www.hp-museum.net/exhibit.php?hwdoc=258</a> >, September 22, 2015; 1 page.	
	NPL100	HP 9145A Tape Drive User's Manual, Edition 1, Hewlett-Packard Corporation, July 1988; 61 pages.	

Examiner Signature	Date Considered
-----------------------	--------------------

\*EXAMINER: Initial if reference considered, whether or not citation is in conformance with MPEP 609. Draw line through citation if not in conformance and not considered. Include copy of this form with next communication to applicant.

<sup>1</sup> Applicant's unique citation designation number (optional). <sup>2</sup> Applicant is to place a check mark here if English language Translation is attached.

Substitute for form 1449/PTO		<b>Complete if Known</b>	
<b>FOURTH SUPPLEMENTAL INFORMATION DISCLOSURE STATEMENT BY APPLICANT</b> <i>(Use as many sheets as necessary)</i>		Application Number	14/876,276
		Filing Date	October 6, 2015
		First Named Inventor	James J. FALLON
		Art Unit	2634
		Examiner Name	BOCURE, TESFALDET
		Attorney Docket Number	3421.005000C
Sheet	11	of	14

NON PATENT LITERATURE DOCUMENTS			
Examiner Initials*	Cite No. <sup>1</sup>	Include name of the author (in CAPITAL LETTERS), title of the article (when appropriate), title of the item (book, magazine, journal, serial, symposium, catalog, etc.), date, page(s), volume number, publisher, city and/or country where published	T <sup>2</sup>
	NPL101	Peripheral Products, HP Computer Museum, accessible at < <a href="http://www.hpmuseum.net/exhibit.php?class=4&amp;cat=85">http://www.hpmuseum.net/exhibit.php?class=4&amp;cat=85</a> >, September 22, 2015; 3 page.	
	NPL102	PALL, G., "Microsoft Point-To-Point Compression (MPPC) Protocol, Request for Comments," The Internet Society, Network Working Group, Hi/fn, Inc., December 1998; 9 pages.	
	NPL103	"Cisco IOS Data Compression," Cisco Systems White Paper, 1997; 10 pages.	
	NPL104	"Reference Software 7751 Encryption Processor," Hi/fn Network Security Processors, Reference Software RS-0001-00, October 1, 1998; 38 pages.	
	NPL105	Screenshot of hifn.com, accessible via the Internet Archive at < <a href="https://web.archive.org/web/19981205163011/http://www.hifn.com">https://web.archive.org/web/19981205163011/http://www.hifn.com</a> >, December 5, 1998; 1 page.	
	NPL106	TESS Record for Serial No. 78040025, filed December 20, 2000, "Typed Drawing," accessed November 10, 2015; 1 page.	
	NPL107	"Compaq Professional Workstation AP500 Key Technologies White Paper," Compaq Computer Corporation, August 1998; 21 pages.	
	NPL108	LANGDON, G., "An Introduction to Arithmetic Coding," IBM Journal of Research and Development, Vol. 28, No. 2, March 1984; pp. 135-149.	
	NPL109	"Connecting Your HP SureStore CD-Writer Plus Drive: Windows 95 and Windows NT 4.0," Hewlett-Packard Corporation, 1997; 50 pages.	
	NPL110	"Quantum Rushmore Solid State Disk Drives," Quantum Corporation, accessible via the Internet Archive at < <a href="http://web.archive.org/web/19980220122303/http://www.quantum.com/products/ssd/">http://web.archive.org/web/19980220122303/http://www.quantum.com/products/ssd/</a> >, February 20, 1998; 2 pages.	

Examiner Signature	Date Considered
-----------------------	--------------------

\*EXAMINER: Initial if reference considered, whether or not citation is in conformance with MPEP 609. Draw line through citation if not in conformance and not considered. Include copy of this form with next communication to applicant.

<sup>1</sup> Applicant's unique citation designation number (optional). <sup>2</sup> Applicant is to place a check mark here if English language Translation is attached.

Substitute for form 1449/PTO		<i>Complete if Known</i>	
<b>FOURTH SUPPLEMENTAL INFORMATION DISCLOSURE STATEMENT BY APPLICANT</b> <i>(Use as many sheets as necessary)</i>		Application Number	14/876,276
		Filing Date	October 6, 2015
		First Named Inventor	James J. FALLON
		Art Unit	2634
		Examiner Name	BOCURE, TESFALDET
		Attorney Docket Number	3421.005000C
Sheet	12	of	14

NON PATENT LITERATURE DOCUMENTS			
Examiner Initials*	Cite No. <sup>1</sup>	Include name of the author (in CAPITAL LETTERS), title of the article (when appropriate), title of the item (book, magazine, journal, serial, symposium, catalog, etc.), date, page(s), volume number, publisher, city and/or country where published	T <sup>2</sup>
	NPL111	"MegaRam Solid State Disks," Imperial Technology, Inc., accessible via the Internet Archive at < <a href="https://web.archive.org/web/19980206055558/http://imperialtech.com/SolidState.html">https://web.archive.org/web/19980206055558/http://imperialtech.com/SolidState.html</a> >, February 6, 1998; 2 pages.	
	NPL112	"Replica - The Fastest, Most Reliable Data Protection For Servers," accessible via the Internet Archive at < <a href="http://web.archive.org/web/19970226213335/http://www1.stac.com/soft/replfct.html">http://web.archive.org/web/19970226213335/http://www1.stac.com/soft/replfct.html</a> >, February 26, 1997; 4 pages.	
	NPL113	"Object Replication: A Revolutionary Advance in Distributed Data Protection and Recovery," Stac White Paper, 1999; 7 pages.	
	NPL114	"Features and Benefits for Replica," Replica for NetWare, 1999; 3 pages.	
	NPL115	DjVu 2.2 Reference Library, August 2000 (submitted on compact disc).	
	NPL116	"Replica - The Fastest, Most Reliable Data Protection for Servers," accessible via the Internet Archive at < <a href="http://web.archive.org/web/19970226213335/http://www1.stac.com/soft/replcont.html">http://web.archive.org/web/19970226213335/http://www1.stac.com/soft/replcont.html</a> >, February 26, 1997; 1 page.	
	NPL117	"Stac Products & Technology," accessible via the Internet Archive at < <a href="http://web.archive.org/web/19970226213054/http://www1.stac.com/soft/softprod.html">http://web.archive.org/web/19970226213054/http://www1.stac.com/soft/softprod.html</a> >, February 26, 1997; 1 page.	
	NPL118	"Hi/fn Product Catalog," accessible via the Internet Archive at < <a href="http://web.archive.org/19971010233632/http://www.hifn.com/products/product/index.htm">http://web.archive.org/19971010233632/http://www.hifn.com/products/product/index.htm</a> >, October 10, 1997; 1 page.	
	NPL119	"Hi/fn Products," accessible via the Internet Archive at < <a href="http://web.archive.org/19971010233115/http://www.hifn.com/products/index.htm">http://web.archive.org/19971010233115/http://www.hifn.com/products/index.htm</a> >, October 10, 1997; 1 page.	
	NPL120	"Replica Family," accessible via the Internet Archive at < <a href="http://web.archive.org/19980212174817/http://www.stac.com/replica/rep_overview.html">http://web.archive.org/19980212174817/http://www.stac.com/replica/rep_overview.html</a> >, February 12, 1998; 1 page.	
Examiner Signature		Date Considered	

\*EXAMINER: Initial if reference considered, whether or not citation is in conformance with MPEP 609. Draw line through citation if not in conformance and not considered. Include copy of this form with next communication to applicant.

<sup>1</sup> Applicant's unique citation designation number (optional). <sup>2</sup> Applicant is to place a check mark here if English language Translation is attached.

Substitute for form 1449/PTO		<b>Complete if Known</b>	
<b>FOURTH SUPPLEMENTAL INFORMATION DISCLOSURE STATEMENT BY APPLICANT</b> <i>(Use as many sheets as necessary)</i>		Application Number	14/876,276
		Filing Date	October 6, 2015
		First Named Inventor	James J. FALLON
		Art Unit	2634
		Examiner Name	BOCURE, TESFALDET
		Attorney Docket Number	3421.005000C
Sheet	13	of	14

NON PATENT LITERATURE DOCUMENTS			
Examiner Initials*	Cite No. <sup>1</sup>	Include name of the author (in CAPITAL LETTERS), title of the article (when appropriate), title of the item (book, magazine, journal, serial, symposium, catalog, etc.), date, page(s), volume number, publisher, city and/or country where published	T <sup>2</sup>
	NPL121	"Stac Web Site Cotents," accessible via the Internet Archive at < <a href="http://web.archive.org/19990827224836/http://www.stac.com/subcontents/sitemap.asp?sitemap">http://web.archive.org/19990827224836/http://www.stac.com/subcontents/sitemap.asp?sitemap</a> >, August 27, 1999; 4 pages.	
	NPL122	"Data Compression Procedures for Data Circuit Terminating Equipment (DCE) Using Error Correcting Procedures," International Telecommunication Union Recommendation V.42 bis, 1990; 29 pages.	
	NPL123	Stac, Inc., News Articles, dated March 10, 1997 to February 2, 1999; 41 pages.	
	NPL124	Orost Archive of Welch Source Code, University of California, 1985; 54 pages.	
	NPL125	Sidewinder 50 Product Manual, Rev. A, Seagate Technology, Inc., 1997; 189 pages. (Submitted in 3 parts.)	
	NPL126	Form 10-Q Quarterly Report Pursuant to Section 13 or 15(d) of the Security Exchange Act of 1934, Stac Software, Inc., filed August 13, 1999; 16 pages.	
	NPL127	"Hi/Fn™ 7711 Encryption Processor™ Shipping in Volume," PR Newswire, April 20, 1998; 2 pages.	
	NPL128	"Lucent Technologies Selects," PR Newswire, March 1, 1999; 2 pages.	
	NPL129	"Stac backs it up with Replica," INFOSTOR, May 1, 1998; 2 pages.	
	NPL130	Court Docket History for Realtime Data, LLC d/b/a IXO v. Actian Corporation, et al., Case No. 6:15-cv-00463 (E.D. Texas), downloaded February 17, 2016, 29 pages.	

Examiner Signature	Date Considered
-----------------------	--------------------

\*EXAMINER: Initial if reference considered, whether or not citation is in conformance with MPEP 609. Draw line through citation if not in conformance and not considered. Include copy of this form with next communication to applicant.

<sup>1</sup> Applicant's unique citation designation number (optional). <sup>2</sup> Applicant is to place a check mark here if English language Translation is attached.



Substitute for form 1449/PTO		<b>Complete if Known</b>	
<b>FOURTH SUPPLEMENTAL INFORMATION DISCLOSURE STATEMENT BY APPLICANT</b> <i>(Use as many sheets as necessary)</i>		Application Number	14/876,276
		Filing Date	October 6, 2015
		First Named Inventor	James J. FALLON
		Art Unit	2634
		Examiner Name	BOCURE, TESFALDET
		Attorney Docket Number	3421.005000C
Sheet	14	of	14

NON PATENT LITERATURE DOCUMENTS			
Examiner Initials*	Cite No. <sup>1</sup>	Include name of the author (in CAPITAL LETTERS), title of the article (when appropriate), title of the item (book, magazine, journal, serial, symposium, catalog, etc.), date, page(s), volume number, publisher, city and/or country where published	T <sup>2</sup>
	NPL131	Court Docket History for Realtime Data, LLC d/b/a IXO v. Dropbox, Inc., Case No. 6:15-cv-00465 (E.D. Texas), downloaded February 17, 2016, 6 pages.	
	NPL132	Court Docket History for Realtime Data, LLC d/b/a IXO v. Echostar Corporation, et al., Case No. 6:15-cv-00466 (E.D. Texas), downloaded February 17, 2016, 3 pages.	
	NPL133	Court Docket History for Realtime Data, LLC d/b/a IXO v. Riverbed Technology, Inc., et al., Case No. 6:15-cv-00468 (E.D. Texas), downloaded February 17, 2016, 3 pages.	
	NPL134	Court Docket History for Realtime Data, LLC d/b/a IXO v. BMC Software, Inc., Case No. 6:15-cv-00464 (E.D. Texas), downloaded February 17, 2016, 3 pages.	
	NPL135	Court Docket History for Realtime Data, LLC d/b/a IXO v. Oracle America, Inc., et al., Case No. 6:15-cv-00467 (E.D. Texas), downloaded February 17, 2016, 4 pages.	
	NPL136	Court Docket History for Realtime Data, LLC d/b/a IXO v. SAP America, Inc., et al., Case No. 6:15-cv-00469 (E.D. Texas), downloaded February 17, 2016, 5 pages.	
	NPL137	Court Docket History for Realtime Data, LLC d/b/a IXO v. Teradata Corporation, et al., Case No. 6:15-cv-00470 (E.D. Texas), downloaded February 17, 2016, 6 pages.	
	NPL138	Court Docket History for Realtime Data, LLC d/b/a IXO v. Apple, Inc., Case No. 6:15-cv-00885 (E.D. Texas), downloaded February 17, 2016, 6 pages.	

2774134\_1.DOCX

Examiner Signature	Date Considered	
-----------------------	--------------------	--

\*EXAMINER: Initial if reference considered, whether or not citation is in conformance with MPEP 609. Draw line through citation if not in conformance and not considered. Include copy of this form with next communication to applicant.

<sup>1</sup> Applicant's unique citation designation number (optional). <sup>2</sup> Applicant is to place a check mark here if English language Translation is attached.

## Electronic Patent Application Fee Transmittal

<b>Application Number:</b>	14876276			
<b>Filing Date:</b>	06-Oct-2015			
<b>Title of Invention:</b>	Video Data Compression Systems			
<b>First Named Inventor/Applicant Name:</b>	James J. FALLON			
<b>Filer:</b>	Michael V. Messinger/William Flanigen			
<b>Attorney Docket Number:</b>	3421.005000C			
Filed as Large Entity				
<b>Filing Fees for Utility under 35 USC 111(a)</b>				
<b>Description</b>	<b>Fee Code</b>	<b>Quantity</b>	<b>Amount</b>	<b>Sub-Total in USD(\$)</b>
<b>Basic Filing:</b>				
<b>Pages:</b>				
<b>Claims:</b>				
<b>Miscellaneous-Filing:</b>				
<b>Petition:</b>				
<b>Patent-Appeals-and-Interference:</b>				
<b>Post-Allowance-and-Post-Issuance:</b>				
<b>Extension-of-Time:</b>				

Description	Fee Code	Quantity	Amount	Sub-Total in USD(\$)
<b>Miscellaneous:</b>				
Submission- Information Disclosure Stmt	1806	1	180	180
<b>Total in USD (\$)</b>				<b>180</b>

## Electronic Acknowledgement Receipt

<b>EFS ID:</b>	25008950
<b>Application Number:</b>	14876276
<b>International Application Number:</b>	
<b>Confirmation Number:</b>	3403
<b>Title of Invention:</b>	Video Data Compression Systems
<b>First Named Inventor/Applicant Name:</b>	James J. FALLON
<b>Customer Number:</b>	26111
<b>Filer:</b>	Michael V. Messinger/William Flanigen
<b>Filer Authorized By:</b>	Michael V. Messinger
<b>Attorney Docket Number:</b>	3421.005000C
<b>Receipt Date:</b>	24-FEB-2016
<b>Filing Date:</b>	06-OCT-2015
<b>Time Stamp:</b>	15:47:36
<b>Application Type:</b>	Utility under 35 USC 111(a)

### Payment information:

Submitted with Payment	yes
Payment Type	Credit Card
Payment was successfully received in RAM	\$180
RAM confirmation Number	2258
Deposit Account	
Authorized User	

The Director of the USPTO is hereby authorized to charge indicated fees and credit any overpayment as follows:

File Listing:					
Document Number	Document Description	File Name	File Size(Bytes)/ Message Digest	Multi Part /.zip	Pages (if appl.)
1		3421005000C_4SIDS.pdf	3352683 f9c9821beaae2272a54a26e5ee3896e8a94fa1f2	yes	24
<b>Multipart Description/PDF files in .zip description</b>					
	Document Description	Start	End		
	Miscellaneous Incoming Letter	1	1		
	Transmittal Letter	2	9		
	Information Disclosure Statement (IDS) Form (SB08)	10	24		
<b>Warnings:</b>					
<b>Information:</b>					
2	Fee Worksheet (SB06)	fee-info.pdf	30303 623cac326255916873dff9d2283dff990947fd565	no	2
<b>Warnings:</b>					
<b>Information:</b>					
<b>Total Files Size (in bytes):</b>			3382986		
<p><b>This Acknowledgement Receipt evidences receipt on the noted date by the USPTO of the indicated documents, characterized by the applicant, and including page counts, where applicable. It serves as evidence of receipt similar to a Post Card, as described in MPEP 503.</b></p> <p><b><u>New Applications Under 35 U.S.C. 111</u></b>  If a new application is being filed and the application includes the necessary components for a filing date (see 37 CFR 1.53(b)-(d) and MPEP 506), a Filing Receipt (37 CFR 1.54) will be issued in due course and the date shown on this Acknowledgement Receipt will establish the filing date of the application.</p> <p><b><u>National Stage of an International Application under 35 U.S.C. 371</u></b>  If a timely submission to enter the national stage of an international application is compliant with the conditions of 35 U.S.C. 371 and other applicable requirements a Form PCT/DO/EO/903 indicating acceptance of the application as a national stage submission under 35 U.S.C. 371 will be issued in addition to the Filing Receipt, in due course.</p> <p><b><u>New International Application Filed with the USPTO as a Receiving Office</u></b>  If a new international application is being filed and the international application includes the necessary components for an international filing date (see PCT Article 11 and MPEP 1810), a Notification of the International Application Number and of the International Filing Date (Form PCT/RO/105) will be issued in due course, subject to prescriptions concerning national security, and the date shown on this Acknowledgement Receipt will establish the international filing date of the application.</p>					

MICHAEL V. MESSINGER  
DIRECTOR  
(202) 772-8667  
MIKEM@SKGF.COM



February 24, 2016

Commissioner for Patents  
PO Box 1450  
Alexandria, VA 22313-1450

Confirmation No. 3403  
Art Unit 2634  
**Attn: Mail Stop Amendment**

Re: U.S. Utility Patent Application  
Application No. 14/876,276; Filing Date: October 6, 2015  
For: **Video Data Compression Systems**  
Inventors: FALLON *et al.*  
Our Ref: 3421.005000C

Commissioner:

Transmitted herewith for appropriate action are the following documents:

1. Online Credit Card Payment Authorization in the amount of \$180.00 in payment of the fee under 37 C.F.R. § 1.17(p);
2. Fourth Supplemental Information Disclosure Statement;
3. Form PTO/SB/08a (1 sheet) listing 6 documents (US1-US6);
4. Form PTO/SB/08b (14 sheets) listing 138 documents (NPL1-NPL138).

*The above-listed documents are filed electronically through EFS-Web.*

In the event that extensions of time are necessary to prevent abandonment of this patent application, then such extensions of time are hereby petitioned.

Fee payment is provided through online credit card payment. The U.S. Patent and Trademark Office is hereby authorized to charge any fee deficiency, or credit any overpayment, to our Deposit Account No. 19-0036.

Respectfully submitted,

STERNE, KESSLER, GOLDSTEIN & FOX P.L.L.C.

A handwritten signature in black ink, appearing to read 'Michael V. Messinger', written over a faint, larger version of the same signature.

Michael V. Messinger  
Attorney for Applicant  
Registration No. 37,575

MVM/MRM/wcf  
Enclosures

2774149\_1.DOCX

IN THE UNITED STATES PATENT AND TRADEMARK OFFICE

Inventors: FALLON *et al.*

Confirmation No.: 3403

Applicant: Realtime Data, LLC

Art Unit: 2634

Application No.: 14/876,276

Examiner: BOCURE, TESHALDET

Filing Date: October 6, 2015

Atty. Docket: 3421.005000C

Title: **Video Data Compression Systems**

**Fourth Supplemental Information Disclosure Statement**

*Mail Stop Amendment*

Commissioner for Patents  
PO Box 1450  
Alexandria, VA 22313-1450

Commissioner:

Notice of Prior and Concurrent Proceedings

Applicant hereby calls to the attention of the Patent and Trademark Office the following reexamination proceedings involving patents that are commonly-assigned with the patent in the above-identified patent application:

<b>Proceeding</b>	<b>Status</b>
Inter Partes Reexamination of U.S. Patent No. 6,604,158 (Control No. 95/000,486)	Inter Partes Reexamination Certificate issued 10/10/2012
Inter Partes Reexamination of U.S. Patent No. 7,321,937 (Control No. 95/000,466)	Inter Partes Reexamination Certificate issued 05/15/2012
Inter Partes Reexamination of U.S. Patent No. 6,604,158 (Control No. 95/000,453)	Terminated
Ex Parte Reexamination of U.S. Patent No. 6,601,104 (Control No. 90/009,428)	Ex Parte Reexamination Certificate issued 02/28/2012
Inter Partes Reexamination of U.S. Patent No. 7,378,992 (Control No. 95/000,478)	Inter Partes Reexamination Certificate issued 10/04/2012
Inter Partes Reexamination of U.S. Patent No. 6,624,761 (Control No. 95/000,464)	Inter Partes Reexamination Certificate issued 06/12/2012
Inter Partes Reexamination of U.S. Patent No. 7,161,506 (Control No. 95/000,479)	Inter Partes Reexamination Certificate issued 05/22/2012

<b>Proceeding</b>	<b>Status</b>
Inter Partes Reexamination of U.S. Patent No. 7,714,747 (Control No. 95/001,517)	Appeal to the Court of Appeals for the Federal Circuit dismissed 6/4/2015
Inter Partes Reexamination of U.S. Patent No. 7,417,568 (Control No. 95/001,533)	Decision on Appeal mailed 10/29/2015
Inter Partes Reexamination of U.S. Patent No. 7,777,651 (Control No. 95/001,581)	Decision on Appeal mailed 10/29/2015
Inter Partes Reexamination of U.S. Patent No. 7,400,274 (Control No. 95/001,544)	Decision on Appeal mailed 10/29/2015

Applicant hereby calls to the attention of the Patent and Trademark Office the following reexamination proceedings filed by Cellco Partnership d/b/a Verizon Wireless, involving patents that are commonly-assigned with the patent in the above-identified patent application:

<b>Proceeding</b>	<b>Status</b>
Inter Partes Reexamination of U.S. Patent No. 7,321,937 (Control No. 95/001,922)	Inter Partes Reexamination Certificate issued 12/05/2013
Inter Partes Reexamination of U.S. Patent No. 6,604,158 (Control No. 95/001,923)	Inter Partes Reexamination Certificate issued 04/17/2015
Inter Partes Reexamination of U.S. Patent No. 7,352,300 (Control No. 95/001,924)	Inter Partes Reexamination Certificate issued 08/04/2014
Inter Partes Reexamination of U.S. Patent No. 7,395,345 (Control No. 95/001,925)	Inter Partes Reexamination Certificate issued 11/03/2014
Inter Partes Reexamination of U.S. Patent No. 7,161,506 (Control No. 95/001,926)	Inter Partes Reexamination Certificate issued 01/08/2014
Inter Partes Reexamination of U.S. Patent No. 7,415,530 (Control No. 95/001,927)	Inter Partes Reexamination Certificate issued 08/16/2013
Inter Partes Reexamination of U.S. Patent No. 7,378,992 (Control No. 95/001,928)	Inter Partes Reexamination Certificate issued 01/08/2014

Applicant invites the Examiner to review the Requests for Reexamination, issued Office Actions, replies, and any other papers in the above-identified reexamination proceedings. If the Examiner is unable to obtain copies of papers in any reexamination proceeding, copies can be

Atty. Dkt. No. 3421,005000C



provided to the Examiner upon request. Those documents which may be material that are not already of record in this patent application are listed on the accompanying Form PTO/SB/08.

Applicant hereby calls to the attention of the Patent and Trademark Office the following *inter partes* review proceedings involving patents that are commonly-assigned with the patent in the above-identified patent application:

<b>Proceeding</b>	<b>Patent</b>	<b>Status</b>
<i>Oracle America, Inc. v. Realtime Data, LLC</i> , IPR2016-00373	7,378,992	Petition filed December 22, 2015
<i>Oracle America, Inc. v. Realtime Data, LLC</i> , IPR2016-00374	8,643,513	Petition filed December 22, 2015
<i>Oracle America, Inc. v. Realtime Data, LLC</i> , IPR2016-00375	7,415,530	Petition filed December 28, 2015
<i>Oracle America, Inc. v. Realtime Data, LLC</i> , IPR2016-00376	7,415,530	Petition filed December 28, 2015
<i>Oracle America, Inc. v. Realtime Data, LLC</i> , IPR2016-00377	9,116,908	Petition filed December 28, 2015

Applicant invites the Examiner to review the petitions for *inter partes* review and any other papers in the above-identified *inter partes* review proceedings. If the Examiner is unable to obtain copies of papers in any *inter partes* review proceeding, copies can be provided to the Examiner upon request. Those documents which may be material that are not already of record in this patent application are listed on the accompanying Form PTO/SB/08.

Notice of Related Litigation

Applicant notifies the Patent and Trademark Office of the following litigation involving U.S. Patents commonly-owned with the current patent application, the subject matter of which may be related to the present patent application:

Atty. Dkt. No. 3421.005000C

No.	Case	Status
1	<i>Realtime Data LLC d/b/a IXO v. Packeteer, Inc. et al.</i> , No. 6:08-cv-00144-LED (E.D. Texas)	Dismissed

Applicant also notifies the Patent and Trademark Office of the following additional litigation involving U.S. Patents commonly-owned with the current patent application, the subject matter of which may be related to the present patent application:

No.	Case	Status
2	<i>Realtime Data LLC d/b/a IXO v. Thomson Reuters Corporation et al.</i> No. 1:11-cv-06698-RJH (S.D. New York) (transferred from E.D. Texas; 6:09-cv-00333-LED)	Case Terminated 11/9/2012; Opinion of the Court of Appeals for the Federal Circuit received 01/27/2014
3	<i>Realtime Data LLC d/b/a IXO v. Morgan Stanley et al.</i> , No. 1:11-cv-06696-RJH (S.D. New York) (transferred from E.D. Texas; 6:09-cv-00326-LED)	Case Terminated 11/9/2012; Opinion of the Court of Appeals for the Federal Circuit received 01/27/2014
4	<i>Realtime Data LLC d/b/a IXO v. CME Group Inc., et al.</i> , No. 1:11-cv-06697-RJH (S.D. New York) (transferred from E.D. Texas; No. 6:09-cv-00327-LED)	Case Terminated 11/9/2012; Opinion of the Court of Appeals for the Federal Circuit received 01/27/2014
5	<i>Chicago Board Options Exchange, Inc., v. Realtime Data LLC d/b/a IXO</i> , No. 09-cv-4486 (N.D. Ill.)	Dismissed
6	<i>Thomson Reuters Corporation v. Realtime Data, LLC d/b/a IXO</i> , No. 1:09-cv-07868-RMB (S.D.N.Y)	Consolidated with Case No. 2
7	<i>Realtime Data, LLC d/b/a IXO v. CME Group Inc., et al. (II)</i> , No. 6:10-cv-246 (E.D. Texas)	Consolidated with Case No. 4
8	<i>Realtime Data LLC d/b/a IXO v. Thomson Reuters Corporation et al. (II)</i> , No. 6:10-cv-247 (E.D. Texas)	Consolidated with Case No. 2
9	<i>Realtime Data, LLC d/b/a IXO v. Morgan Stanley, et al. (II)</i> , No. 6:10-cv-248 (E.D. Texas)	Consolidated with Case No. 3
10	<i>Realtime Data, LLC d/b/a IXO v. MetroPCS Texas, LLC et al.</i> , No. 6:10-cv-00493 (E.D. Texas)	Appeal Terminated

11	<i>Realtime Data, LLC d/b/a IXO v. Microsoft Corporation, et al.</i> , No. 4:14-cv-00827 (E.D. Texas)	Dismissed May 1, 2015
12	<i>Realtime Data, LLC d/b/a IXO v. Actian Corporation, et al.</i> , No. 6:15-cv-00463 (E.D. Texas)	Amended Complaints for Patent Infringement filed September 14, 2015
13	<i>Realtime Data, LLC d/b/a IXO v. Dropbox, Inc.</i> , No. 6:15-cv-00465 (E.D. Texas)	Dismissed February 22, 2016
14	<i>Realtime Data, LLC d/b/a IXO v. Echostar Corporation, et al.</i> , No. 6:15-cv-00466 (E.D. Texas)	Consolidated with Case No. 12; Answer to Amended Complaint filed February 4, 2016
15	<i>Realtime Data, LLC d/b/a IXO v. Riverbed Technology, Inc., et al.</i> , No. 6:15-cv-00468 (E.D. Texas)	Consolidated with Case No. 12; Second Amended Complaint for Infringement filed February 2, 2016
16	<i>Realtime Data, LLC d/b/a IXO v. BMC Software, Inc.</i> , No. 6:15-cv-00464 (E.D. Texas)	Terminated October 5, 2015
17	<i>Realtime Data, LLC d/b/a IXO v. Oracle America, Inc., et al.</i> , No. 6:15-cv-00467 (E.D. Texas)	Consolidated with Case No. 12
18	<i>Realtime Data, LLC d/b/a IXO v. SAP America, Inc., et al.</i> , No. 6:15-cv-00469 (E.D. Texas)	Consolidated with Case No. 12; Answers to Amended Complaint filed February 4, 2016
19	<i>Realtime Data, LLC d/b/a IXO v. Teradata Corporation, et al.</i> , No. 6:15-cv-00470 (E.D. Texas)	Transferred to the Northern District of California, January 19, 2016
20	<i>Realtime Data, LLC d/b/a IXO v. Apple, Inc.</i> , No. 6:15-cv-00885 (E.D. Texas)	Order Granting Motion to Stay entered February 11, 2016

Updated court docket histories for pending litigations are submitted herewith as documents NPL130-NPL138.

Information Disclosure Statement

Listed on accompanying IDS Forms PTO/SB/08a equivalent and PTO/SB/08b equivalent are documents that may be considered material to the patentability of this application as defined in 37 C.F.R. §1.56, and in compliance with the duty of disclosure requirements of 37 C.F.R. §§ 1.97 and 1.98.

Applicant has listed publication dates on the attached IDS Forms based on information presently available to the undersigned. However, the listed publication dates should not be construed as an admission that the information was actually published on the date indicated.

Applicant reserves the right to establish the patentability of the claimed invention over any of the information provided herewith, and/or to prove that this information may not be prior art, and/or to prove that this information may not be enabling for the teachings purportedly offered.

This statement should not be construed as a representation that a search has been made, or that information more material to the examination of the present patent application does not exist. The Examiner is specifically requested not to rely solely on the material submitted herewith.

Filing under 37 C.F.R. § 1.97(c). This Information Disclosure Statement is being filed more than three months after the U.S. filing date AND after the mailing date of the first Office Action on the merits, but before the mailing date of a Final Rejection, or Notice of Allowance, or an action that otherwise closes prosecution in the application. The required fee is provided through online

credit card payment authorization in the amount of \$180.00 in payment of the fee under 37 C.F.R. § 1.17(p).

In accordance with 37 C.F.R. § 1.98(a)(2)(ii), no copies of the U.S. patents and patent application publication cited as documents **US1-US6** on the attached IDS Forms are submitted.

Copies of documents **NPL1-NPL138** were cited by or submitted to the Office in an IDS that complies with 37 C.F.R. § 1.98(a)-(c) in Application No. 14/733,565, filed June 8, 2015 (now pending), which is relied upon for an earlier filing date under 35 U.S.C. § 120. Thus, copies of these documents are not attached. 37 C.F.R. § 1.98(d).

It is expected that the examiner will review the prosecution and cited art in the parent application nos. 14/733,565, filed June 8, 2015 (now pending); 14/577,286, filed December 19, 2014 (now abandoned); 14/134,933, filed December 19, 2013 (now U.S. Patent No. 8,929,442); 14/033,245, filed September 20, 2013 (now U.S. Patent No. 8,934,535); 13/154,239, filed June 6, 2011 (now U.S. Patent No. 8,553,759); 12/123,081, filed May 19, 2008 (now U.S. Patent No. 8,073,047); and 10/076,013, filed February 13, 2002 (now U.S. Patent No. 7,386,046), in accordance with MPEP 2001.06(b), and indicate in the next communication from the office that the art cited in the earlier prosecution history has been reviewed in connection with the present application.

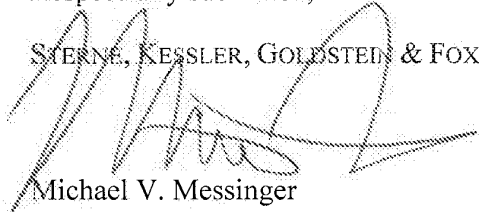
It is respectfully requested that the Examiner initial and return a copy of the enclosed IDS Forms, and indicate in the official file wrapper of this patent application that the documents have been considered.

Atty. Dkt. No. 3421.005000C

The U.S. Patent and Trademark Office is hereby authorized to charge any fee deficiency, or credit any overpayment, to our Deposit Account No. 19-0036.

Respectfully submitted,

STERNE, KESSLER, GOLDSTEIN & FOX P.L.L.C.



Michael V. Messinger  
Attorney for Applicant  
Registration No. 37,575

Date: February 24, 2016

1100 New York Avenue, N.W.  
Washington, D.C. 20005-3934  
(202) 371-2600

2774143\_1.DOCX



UNITED STATES PATENT AND TRADEMARK OFFICE

UNITED STATES DEPARTMENT OF COMMERCE  
United States Patent and Trademark Office  
Address: COMMISSIONER FOR PATENTS  
P.O. Box 1450  
Alexandria, Virginia 22313-1450  
www.uspto.gov

APPLICATION NO.	FILING DATE	FIRST NAMED INVENTOR	ATTORNEY DOCKET NO.	CONFIRMATION NO.
14/876,276	10/06/2015	James J. FALLON	3421.005000C	3403

26111 7590 03/29/2016  
STERNE, KESSLER, GOLDSSTEIN & FOX P.L.L.C.  
1100 NEW YORK AVENUE, N.W.  
WASHINGTON, DC 20005

EXAMINER
----------

BOCURE, TESFALDET

ART UNIT	PAPER NUMBER
----------	--------------

2634

MAIL DATE	DELIVERY MODE
-----------	---------------

03/29/2016

PAPER

**Please find below and/or attached an Office communication concerning this application or proceeding.**

The time period for reply, if any, is set in the attached communication.

<b>Applicant-Initiated Interview Summary</b>	<b>Application No.</b> 14/876,276	<b>Applicant(s)</b> FALLON ET AL.	
	<b>Examiner</b> TESFALDET BOCURE	<b>Art Unit</b> 2634	

All participants (applicant, applicant's representative, PTO personnel):

- (1) TESFALDET BOCURE. (3)\_\_\_\_\_.
- (2) Mr. Malek Michael (Mike), Attorney Reg. # 65211. (4)\_\_\_\_\_.

Date of Interview: 23 March 2016.

Type:  Telephonic  Video Conference  
 Personal [copy given to:  applicant  applicant's representative]

Exhibit shown or demonstration conducted:  Yes  No.  
If Yes, brief description: \_\_\_\_\_.

Issues Discussed 101 112 102 103 Others  
(For each of the checked box(es) above, please describe below the issue and detailed description of the discussion)

Claim(s) discussed: 1 and 19.

Identification of prior art discussed: none.

**Substance of Interview**

(For each issue discussed, provide a detailed description and indicate if agreement was reached. Some topics may include: identification or clarification of a reference or a portion thereof, claim interpretation, proposed amendments, arguments of any applied references etc...)

See attached detail action.

**Applicant recordation instructions:** The formal written reply to the last Office action must include the substance of the interview. (See MPEP section 713.04). If a reply to the last Office action has already been filed, applicant is given a non-extendable period of the longer of one month or thirty days from this interview date, or the mailing date of this interview summary form, whichever is later, to file a statement of the substance of the interview

**Examiner recordation instructions:** Examiners must summarize the substance of any interview of record. A complete and proper recordation of the substance of an interview should include the items listed in MPEP 713.04 for complete and proper recordation including the identification of the general thrust of each argument or issue discussed, a general indication of any other pertinent matters discussed regarding patentability and the general results or outcome of the interview, to include an indication as to whether or not agreement was reached on the issues raised.

Attachment

/TESFALDET BOCURE/  
Primary Examiner, Art Unit 2634



## Summary of Record of Interview Requirements

### Manual of Patent Examining Procedure (MPEP), Section 713.04, Substance of Interview Must be Made of Record

A complete written statement as to the substance of any face-to-face, video conference, or telephone interview with regard to an application must be made of record in the application whether or not an agreement with the examiner was reached at the interview.

### Title 37 Code of Federal Regulations (CFR) § 1.133 Interviews Paragraph (b)

In every instance where reconsideration is requested in view of an interview with an examiner, a complete written statement of the reasons presented at the interview as warranting favorable action must be filed by the applicant. An interview does not remove the necessity for reply to Office action as specified in §§ 1.111, 1.135. (35 U.S.C. 132)

#### 37 CFR §1.2 Business to be transacted in writing.

All business with the Patent or Trademark Office should be transacted in writing. The personal attendance of applicants or their attorneys or agents at the Patent and Trademark Office is unnecessary. The action of the Patent and Trademark Office will be based exclusively on the written record in the Office. No attention will be paid to any alleged oral promise, stipulation, or understanding in relation to which there is disagreement or doubt.

The action of the Patent and Trademark Office cannot be based exclusively on the written record in the Office if that record is itself incomplete through the failure to record the substance of interviews.

It is the responsibility of the applicant or the attorney or agent to make the substance of an interview of record in the application file, unless the examiner indicates he or she will do so. It is the examiner's responsibility to see that such a record is made and to correct material inaccuracies which bear directly on the question of patentability.

Examiners must complete an Interview Summary Form for each interview held where a matter of substance has been discussed during the interview by checking the appropriate boxes and filling in the blanks. Discussions regarding only procedural matters, directed solely to restriction requirements for which interview recordation is otherwise provided for in Section 812.01 of the Manual of Patent Examining Procedure, or pointing out typographical errors or unreadable script in Office actions or the like, are excluded from the interview recordation procedures below. Where the substance of an interview is completely recorded in an Examiners Amendment, no separate Interview Summary Record is required.

The Interview Summary Form shall be given an appropriate Paper No., placed in the right hand portion of the file, and listed on the "Contents" section of the file wrapper. In a personal interview, a duplicate of the Form is given to the applicant (or attorney or agent) at the conclusion of the interview. In the case of a telephone or video-conference interview, the copy is mailed to the applicant's correspondence address either with or prior to the next official communication. If additional correspondence from the examiner is not likely before an allowance or if other circumstances dictate, the Form should be mailed promptly after the interview rather than with the next official communication.

The Form provides for recordation of the following information:

- Application Number (Series Code and Serial Number)
- Name of applicant
- Name of examiner
- Date of interview
- Type of interview (telephonic, video-conference, or personal)
- Name of participant(s) (applicant, attorney or agent, examiner, other PTO personnel, etc.)
- An indication whether or not an exhibit was shown or a demonstration conducted
- An identification of the specific prior art discussed
- An indication whether an agreement was reached and if so, a description of the general nature of the agreement (may be by attachment of a copy of amendments or claims agreed as being allowable). Note: Agreement as to allowability is tentative and does not restrict further action by the examiner to the contrary.
- The signature of the examiner who conducted the interview (if Form is not an attachment to a signed Office action)

It is desirable that the examiner orally remind the applicant of his or her obligation to record the substance of the interview of each case. It should be noted, however, that the Interview Summary Form will not normally be considered a complete and proper recordation of the interview unless it includes, or is supplemented by the applicant or the examiner to include, all of the applicable items required below concerning the substance of the interview.

A complete and proper recordation of the substance of any interview should include at least the following applicable items:

- 1) A brief description of the nature of any exhibit shown or any demonstration conducted,
- 2) an identification of the claims discussed,
- 3) an identification of the specific prior art discussed,
- 4) an identification of the principal proposed amendments of a substantive nature discussed, unless these are already described on the Interview Summary Form completed by the Examiner,
- 5) a brief identification of the general thrust of the principal arguments presented to the examiner,  
(The identification of arguments need not be lengthy or elaborate. A verbatim or highly detailed description of the arguments is not required. The identification of the arguments is sufficient if the general nature or thrust of the principal arguments made to the examiner can be understood in the context of the application file. Of course, the applicant may desire to emphasize and fully describe those arguments which he or she feels were or might be persuasive to the examiner.)
- 6) a general indication of any other pertinent matters discussed, and
- 7) if appropriate, the general results or outcome of the interview unless already described in the Interview Summary Form completed by the examiner.

Examiners are expected to carefully review the applicant's record of the substance of an interview. If the record is not complete and accurate, the examiner will give the applicant an extendable one month time period to correct the record.

### Examiner to Check for Accuracy

If the claims are allowable for other reasons of record, the examiner should send a letter setting forth the examiner's version of the statement attributed to him or her. If the record is complete and accurate, the examiner should place the indication, "Interview Record OK" on the paper recording the substance of the interview along with the date and the examiner's initials.

1. The present application is being examined under the pre-AIA first to invent provisions.

***Applicant Initiated Interview Summary***

2. Applicant's representative Mr. Malek Michael (Mike), Attorney Reg. # 65211, called Examiner on 03/17/2017 and proposed to delete the claimed limitation, "for compressing video data, "in the preamble of the independent claims 1 and 19 in order to overcome the 112 2<sup>nd</sup> paragraph rejection indicated in the office action mailed on 01/28/2016. After reviewing the proposed amendment, Examiner called back on 03/23/2016 and agreed that the proposed amendment will overcome the 112 second paragraph rejection. Examiner suggests Mr. Malek that the proposed amendment would not guarantee that there would not be any applicable art to reject the claims.

Further Mr. Malek argued that the proposed amendment to the abstract filed in the preliminary amendment of 12/11/2015 reflects to the claimed invention of the instant application. The abstract was not properly indexed in the file (eDAN), where Examiner did not locate the preliminary amendment when the case was first examined. Examiner agreed that the amendment to abstract reflects the claimed invention and the objection will be withdrawn.

***Conclusion***

3. Any inquiry concerning this communication or earlier communications from the examiner should be directed to TESFALDET BOCURE whose telephone number is (571)272-3015. The examiner can normally be reached on 8:30am-to-5:00pm.

If attempts to reach the examiner by telephone are unsuccessful, the examiner's supervisor, Daniel C. Washburn can be reached on 571-272-5551. The fax phone number for the organization where this application or proceeding is assigned is 571-273-8300.

Information regarding the status of an application may be obtained from the Patent Application Information Retrieval (PAIR) system. Status information for published applications may be obtained from either Private PAIR or Public PAIR. Status information for unpublished applications is available through Private PAIR only. For more information about the PAIR system, see <http://pair-direct.uspto.gov>. Should you have questions on access to the Private PAIR system, contact the Electronic Business Center (EBC) at 866-217-9197 (toll-free). If you would like assistance from a USPTO Customer Service Representative or access to the automated information system, call 800-786-9199 (IN USA OR CANADA) or 571-272-1000.

/TESFALDET BOCURE/  
Primary Examiner, Art Unit 2634

/T. B./  
Primary Examiner, Art Unit 2634

IN THE UNITED STATES PATENT AND TRADEMARK OFFICE

Inventors: FALLON *et al.*

Applicant: Realtime Data, LLC

Application No.: 14/876,276

Filing Date: October 6, 2015

Title: **Video Data Compression Systems**

Confirmation No.: 3403

Art Unit: 2634

Examiner: BOCURE, TESFALDET

Atty. Docket: 3421.005000C

**Amendment and Reply Under 37 C.F.R. § 1.111**

***Mail Stop Amendment***

Commissioner for Patents  
PO Box 1450  
Alexandria, VA 22313-1450

Commissioner:

In reply to the Office Action dated January 28, 2016 (“Office Action”), Applicant submits the following Amendment and Remarks.

It is not believed that extensions of time are required beyond those that may otherwise be provided for in documents accompanying this paper. However, if additional extensions of time are necessary to prevent abandonment of this Application, then such extensions of time are hereby petitioned under 37 C.F.R. § 1.136(a), and any additional fees required to continue prosecution or appeal of this Application (including issue fee, fees for net addition of claims or forwarding to appeal) are hereby authorized to be charged to our Deposit Account No. 19-0036.

*Amendments to the Claims*

This listing of claims will replace all prior versions, and listings, of claims in this Application.

1. (Currently Amended) A system ~~for compressing video data~~, comprising:  
a plurality of different asymmetric data compression algorithms, wherein a first asymmetric data compression algorithm of the plurality of different asymmetric data compression algorithms is configured to compress data at a higher data compression rate than a second asymmetric data compression algorithm of the plurality of different asymmetric data compression algorithms, wherein compression rate is measured in bits per second; and  
one or more processors configured to:  
determine one or more data parameters from one or more data blocks containing video data, at least one of the one or more data parameters relating to a throughput of a communications channel; and  
select one or more asymmetric data compression algorithms from among the plurality of different asymmetric data compression algorithms based upon, at least in part, the determined one or more data parameters.

2. (Currently Amended) The system of claim 1 wherein at least one of the plurality of different asymmetric data compression algorithms is an arithmetic ~~encoder~~ algorithm.

3. (Original) The system of claim 1, wherein the throughput of the communications

channel comprises:

an actual throughput of the communications channel.

4. (Original) The system of claim 1, wherein the throughput of the communications channel comprises:

an estimated throughput of the communications channel.

5. (Original) The system of claim 1, wherein the throughput of the communications channel comprises:

an expected throughput of the communications channel.

6. (Previously Presented) The system of claim 1, wherein the one or more different asymmetric data compression algorithms are configured to compress the one or more data blocks containing video data for different data transmission rates to produce a plurality of compressed data blocks.

7. (Previously Presented) The system of claim 1, wherein at least one of the plurality of different asymmetric data compression algorithms comprises:

a lossless data compression algorithm.

8. (Original) The system of claim 1, wherein at least one of the one or more data parameters comprises:

a resolution of the one or more data blocks containing video data.

9. (Original) The system of claim 1, wherein at least one of the one or more data parameters comprises:

a data transmission rate of the one or more data blocks containing video data.

10. (Original) The system of claim 1, wherein at least one of the one or more data parameters comprises:

an attribute or a value related to a format or a syntax of video data contained in the one or more data blocks containing video data.

11. (Previously Presented) The system of claim 1, wherein the selected one or more asymmetric data compression algorithms comprise:

a content-dependent data compression algorithm.

12. (Previously Presented) The system of claim 11, wherein the content-dependent data compression algorithm comprises:

an arithmetic algorithm.

13. (Previously Presented) The system of claim 1, wherein the selected one or more asymmetric data compression algorithms are configured to perform compression in real-time or substantially real-time.

14. (Original) The system of claim 1, wherein the communications channel comprises:

a distributed network.

15. (Original) The system of claim 14, wherein the distributed network comprises:  
the Internet.

16. (Previously Presented) The system of claim 1, wherein the selected one or more asymmetric data compression algorithms are utilized to compress the one or more data blocks containing video data to create one or more compressed data blocks, and  
wherein a descriptor is associated with the one or more compressed data blocks that indicates the selected one or more asymmetric data compression algorithms.

17. (Previously Presented) The system of claim 1, wherein the selected one or more asymmetric data compression algorithms are utilized to compress the one or more data blocks containing video data to create one or more compressed data blocks, and  
wherein a descriptor indicating the selected one or more asymmetric data compression algorithms is included with the one or more compressed data blocks.

18. (Original) The system of claim 1, wherein at least one of the one or more data parameters comprises:



a video data profile.

19. (Currently Amended) A system ~~for compressing video data~~, comprising:

a plurality of data compression algorithms;

wherein at least one of the plurality of data compression algorithms comprises an asymmetric data compression algorithm, and

wherein at least one of the plurality of data compression algorithms comprises an arithmetic data compression algorithm,

wherein a first data compression algorithm of the plurality of data compression algorithms is configured to compress more bits per second of data than a second data compression algorithm of the plurality of data compression algorithms; and

one or more processors configured to:

determine one or more data parameters from one or more data blocks containing video data, at least one of the one or more data parameters relating to a throughput of a communications channel; and

select one or more data compression algorithms from among the plurality of data compression algorithms based upon, at least in part, the determined one or more data parameters.

20. (Original) The system of claim 19, wherein the throughput of the communications channel comprises:

an actual throughput of the communications channel.

21. (Original) The system of claim 19, wherein the throughput of the communications channel comprises:

an estimated or expected throughput of the communications channel.

22. (Previously Presented) The system of claim 19, wherein the selected one or more data compression algorithms are configured to compress the one or more data blocks containing video data for different data transmission rates to produce a plurality of compressed data blocks.

23. (Previously Presented) The system of claim 19, wherein at least one of the plurality of data compression algorithms comprises:

a lossless data compression algorithm.

24. (Original) The system of claim 19, wherein at least one of the one or more data parameters are related to a resolution of the one or more data blocks containing video data.

25. (Original) The system of claim 19, wherein at least one of the one or more data parameters comprises:

a data transmission rate of the one or more data blocks containing video data.

26. (Original) The system of claim 19, wherein at least one of the one or more data parameters comprises:

an attribute or a value related to a format or a syntax of video data contained in the one or more data blocks containing video data.

27. (Previously Presented) The system of claim 19, wherein the selected one or more data compression algorithms perform data compression in real-time or substantially real-time.

28. (Original) The system of claim 19, wherein the communications channel comprises:

a distributed network or the Internet.

29. (Previously Presented) The system of claim 19, wherein the one or more data blocks are compressed with the selected the one or more selected data compression algorithms to create one or more compressed data blocks, and

wherein a descriptor is associated with the one or more compressed data blocks that indicates the selected data compression algorithm.

30. (Original) The system of claim 19, wherein at least one of the one or more data parameters comprises:

a video data profile.

*Amendments to the Abstract*

1. Applicant respectfully requests the Abstract of the Disclosure as amended in the Preliminary Amendment Under 37 C.F.R. § 1.115 that was filed on December 11, 2015 be further amended as follows:

~~A system and method for compressing data is disclosed. The system and method include~~  
including one or more ~~[[of]]~~ asymmetric data compression algorithms is disclosed. A first asymmetric data compression algorithm of the one or more asymmetric data compression algorithms compresses data at a higher data compression rate than a second asymmetric data compression algorithm of the one or more asymmetric data compression algorithms. The system and method also include one or more processors that determine one or more data parameters from one or more data blocks and select one or more asymmetric data compression algorithms from among the one or more asymmetric data compression algorithms based upon, at least in part, the determined one or more data parameters.

*Remarks*

Reconsideration of this Application is respectfully requested.

Upon entry of the foregoing amendment, claims 1-30 are pending in this Application, with claims 1 and 19 being the independent claims. Claims 1, 2, and 19 are sought to be amended. Applicant reserves the right to prosecute similar or broader claims, with respect to the amended claims, in the future. The Abstract of the Disclosure as amended in the Preliminary Amendment Under 37 C.F.R. § 1.115 that was filed on December 11, 2015 is sought to be further amended. These changes are believed to introduce no new matter, and their entry is respectfully requested.

Based on the above amendment and the following remarks, Applicant respectfully requests that the Examiner reconsider all outstanding objections and rejections and that they be withdrawn.

*Statement of the Substance of the Interview*

Pursuant to 37 C.F.R. § 1.133, Applicant provides the following statement of substance of the interview. Applicant expresses their appreciation to Examiner Tesfaldet Bocure for the courtesy of telephonic interviews with Applicant's representative, Michael R. Malek, Reg. No. 65,211, on March 15, 2016 and March 21, 2016. During the interviews, an agreement was reached that the amendments to independent claims 1 and 16 presented herewith overcome the objections to claims 1-30 and the rejections to claims 1-30 under U.S.C. § 112, second paragraph, as presented in the Office Action. Furthermore, the Examiner also agreed that the Amendment to the Specification in the Preliminary Amendment Under 37 C.F.R. § 1.115 that was filed on December 11, 2015 ("Preliminary Amendment") overcomes the objection to the Specification as presented in the Office Action.

Atty. Dkt. No. 3421.005000C

***Objection to the Specification***

The Specification stands objected to because of alleged informalities. As discussed in the Statement of the Substance of the Interview above, the Examiner agreed that the Amendment to the Specification in the Preliminary Amendment overcomes this objection to the Specification. (*See*, Preliminary Amendment, p. 2) Accordingly, Applicant respectfully request the objection to the Specification be reconsidered and withdrawn.

***Objection to the Claims***

Claims 1-30 stand objected to because of alleged informalities. Without acquiescing to the merits of this allegation, Applicant has amended independent claims 1 and 19 herewith to overcome this objection for the sole purpose of advancing prosecution of this Application. As discussed in the Statement of the Substance of the Interview above, the Examiner agreed that these amendments to independent claims 1 and 19 overcome this objection. Accordingly, Applicant respectfully request the objection to claims 1-30 be reconsidered and withdrawn.

***Rejections under 35 U.S.C. § 112***

Claim 1-30 stand rejected under 35 U.S.C. § 112, second paragraph, for allegedly being indefinite. Without acquiescing to the merits of this allegation, Applicant has amended independent claims 1 and 19 herewith to overcome this rejection for the sole purpose of advancing prosecution of this Application. As discussed in the Statement of the Substance of the Interview above, the Examiner agreed that these amendments to independent claims 1 and 19 overcome this rejection.

Reply to Office Action of January 28, 2016

FALLON *et al.*  
Application No. 14/876,276

Accordingly, Applicant respectfully requests the rejection to claims 1-30 under 35 U.S.C. § 112, second paragraph, be reconsidered and withdrawn.

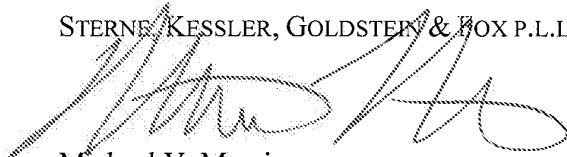
***Conclusion***

All of the stated grounds of objection and rejection have been properly traversed, accommodated, or rendered moot. Applicant therefore respectfully requests that the Examiner reconsider all presently outstanding objections and rejections and that they be withdrawn. Applicant believes that a full and complete reply has been made to the outstanding Office Action and, as such, this Application is in condition for allowance. If the Examiner believes, for any reason, that personal communication will expedite prosecution of this Application, the Examiner is invited to telephone the undersigned at the number provided.

Prompt and favorable consideration of this Amendment and Reply is respectfully requested.

Respectfully submitted,

STERNE, KESSLER, GOLDSTEIN & FOX P.L.L.C.



Michael V. Messinger  
Attorney for Applicant  
Registration No. 37,575

Date: \_\_\_\_\_

*April 12, 2016*

1100 New York Avenue, N.W.  
Washington, D.C. 20005-3934  
(202) 371-2600

2764988\_1

Atty. Dkt. No. 3421.005000C

IN THE UNITED STATES PATENT AND TRADEMARK OFFICE

Inventors: FALLON *et al.*

Applicant: Realtime Data, LLC

Application No.: 14/876,276

Filing Date: October 6, 2015

Title: **Video Data Compression Systems**

Confirmation No.: 3403

Art Unit: 2634

Examiner: BOCURE, TESFALDET

Atty. Docket: 3421.005000C

**Fifth Supplemental Information Disclosure Statement**

*Mail Stop Amendment*

Commissioner for Patents  
PO Box 1450  
Alexandria, VA 22313-1450

Commissioner:

Notice of Prior and Concurrent Proceedings

Applicant hereby calls to the attention of the Patent and Trademark Office the following reexamination proceedings involving patents that are commonly-assigned with the patent in the above-identified patent application:

<b>Proceeding</b>	<b>Status</b>
Inter Partes Reexamination of U.S. Patent No. 6,604,158 (Control No. 95/000,486)	Inter Partes Reexamination Certificate issued 10/10/2012
Inter Partes Reexamination of U.S. Patent No. 7,321,937 (Control No. 95/000,466)	Inter Partes Reexamination Certificate issued 05/15/2012
Inter Partes Reexamination of U.S. Patent No. 6,604,158 (Control No. 95/000,453)	Terminated
Ex Parte Reexamination of U.S. Patent No. 6,601,104 (Control No. 90/009,428)	Ex Parte Reexamination Certificate issued 02/28/2012
Inter Partes Reexamination of U.S. Patent No. 7,378,992 (Control No. 95/000,478)	Inter Partes Reexamination Certificate issued 10/04/2012
Inter Partes Reexamination of U.S. Patent No. 6,624,761 (Control No. 95/000,464)	Inter Partes Reexamination Certificate issued 06/12/2012
Inter Partes Reexamination of U.S. Patent No. 7,161,506 (Control No. 95/000,479)	Inter Partes Reexamination Certificate issued 05/22/2012



<b>Proceeding</b>	<b>Status</b>
Inter Partes Reexamination of U.S. Patent No. 7,714,747 (Control No. 95/001,517)	Appeal to the Court of Appeals for the Federal Circuit dismissed 6/4/2015
Inter Partes Reexamination of U.S. Patent No. 7,417,568 (Control No. 95/001,533)	Decision on Appeal mailed 10/29/2015
Inter Partes Reexamination of U.S. Patent No. 7,777,651 (Control No. 95/001,581)	Decision on Appeal mailed 10/29/2015
Inter Partes Reexamination of U.S. Patent No. 7,400,274 (Control No. 95/001,544)	Decision on Appeal mailed 10/29/2015

Applicant hereby calls to the attention of the Patent and Trademark Office the following reexamination proceedings filed by Cellco Partnership d/b/a Verizon Wireless, involving patents that are commonly-assigned with the patent in the above-identified patent application:

<b>Proceeding</b>	<b>Status</b>
Inter Partes Reexamination of U.S. Patent No. 7,321,937 (Control No. 95/001,922)	Inter Partes Reexamination Certificate issued 12/05/2013
Inter Partes Reexamination of U.S. Patent No. 6,604,158 (Control No. 95/001,923)	Inter Partes Reexamination Certificate issued 04/17/2015
Inter Partes Reexamination of U.S. Patent No. 7,352,300 (Control No. 95/001,924)	Inter Partes Reexamination Certificate issued 08/04/2014
Inter Partes Reexamination of U.S. Patent No. 7,395,345 (Control No. 95/001,925)	Inter Partes Reexamination Certificate issued 11/03/2014
Inter Partes Reexamination of U.S. Patent No. 7,161,506 (Control No. 95/001,926)	Inter Partes Reexamination Certificate issued 01/08/2014
Inter Partes Reexamination of U.S. Patent No. 7,415,530 (Control No. 95/001,927)	Inter Partes Reexamination Certificate issued 08/16/2013
Inter Partes Reexamination of U.S. Patent No. 7,378,992 (Control No. 95/001,928)	Inter Partes Reexamination Certificate issued 01/08/2014

Applicant invites the Examiner to review the Requests for Reexamination, issued Office Actions, replies, and any other papers in the above-identified reexamination proceedings. If the Examiner is unable to obtain copies of papers in any reexamination proceeding, copies can be

provided to the Examiner upon request. Those documents which may be material that are not already of record in this patent application are listed on the accompanying Form PTO/SB/08.

Applicant hereby calls to the attention of the Patent and Trademark Office the following *inter partes* review proceedings involving patents that are commonly-assigned with the patent in the above-identified patent application:

Proceeding	Patent	Status
<i>Oracle America, Inc. v. Realtime Data, LLC</i> , IPR2016-00373	7,378,992	Patent Owner Preliminary Response Filed April 7, 2016
<i>Oracle America, Inc. v. Realtime Data, LLC</i> , IPR2016-00374	8,643,513	Patent Owner Preliminary Response Filed April 8, 2016
<i>Oracle America, Inc. v. Realtime Data, LLC</i> , IPR2016-00375	7,415,530	Patent Owner Preliminary Response Filed April 11, 2016
<i>Oracle America, Inc. v. Realtime Data, LLC</i> , IPR2016-00376	7,415,530	Patent Owner Preliminary Response Filed April 11, 2016
<i>Oracle America, Inc. v. Realtime Data, LLC</i> , IPR2016-00377	9,116,908	Patent Owner Preliminary Response Filed April 11, 2016
<i>SAP America Inc., et al. v. Realtime Data, LLC d/b/a IXO</i> , IPR2016-00783	6,597,812	Petition filed April 1, 2016

Applicant invites the Examiner to review the petitions for *inter partes* review and any other papers in the above-identified *inter partes* review proceedings. If the Examiner is unable to obtain copies of papers in any *inter partes* review proceeding, copies can be provided to the Examiner upon request. Those documents which may be material that are not already of record in this patent application are listed on the accompanying Form PTO/SB/08 as documents **US1-US2** and **NPL12-NPL18**.

Atty. Dkt. No. 3421.005000C

Notice of Related Litigation

Applicant notifies the Patent and Trademark Office of the following litigation involving U.S. Patents commonly-owned with the current patent application, the subject matter of which may be related to the present patent application:

No.	Case	Status
1	<i>Realtime Data LLC d/b/a IXO v. Packeteer, Inc. et al.</i> , No. 6:08-cv-00144-LED (E.D. Texas)	Dismissed

Applicant also notifies the Patent and Trademark Office of the following additional litigation involving U.S. Patents commonly-owned with the current patent application, the subject matter of which may be related to the present patent application:

No.	Case	Status
2	<i>Realtime Data LLC d/b/a IXO v. Thomson Reuters Corporation et al.</i> No. 1:11-cv-06698-RJH (S.D. New York) (transferred from E.D. Texas; 6:09-cv-00333-LED)	Case Terminated 11/9/2012; Opinion of the Court of Appeals for the Federal Circuit received 01/27/2014
3	<i>Realtime Data LLC d/b/a IXO v. Morgan Stanley et al.</i> , No. 1:11-cv-06696-RJH (S.D. New York) (transferred from E.D. Texas; 6:09-cv-00326-LED)	Case Terminated 11/9/2012; Opinion of the Court of Appeals for the Federal Circuit received 01/27/2014
4	<i>Realtime Data LLC d/b/a IXO v. CME Group Inc., et al.</i> , No. 1:11-cv-06697-RJH (S.D. New York) (transferred from E.D. Texas; No. 6:09-cv-00327-LED)	Case Terminated 11/9/2012; Opinion of the Court of Appeals for the Federal Circuit received 01/27/2014
5	<i>Chicago Board Options Exchange, Inc., v. Realtime Data LLC d/b/a IXO</i> , No. 09-cv-4486 (N.D. Ill.)	Dismissed

6	<i>Thomson Reuters Corporation v. Realtime Data, LLC d/b/a IXO</i> , No. 1:09-cv-07868-RMB (S.D.N.Y)	Consolidated with Case No. 2
7	<i>Realtime Data, LLC d/b/a IXO v. CME Group Inc., et al. (II)</i> , No. 6:10-cv-246 (E.D. Texas)	Consolidated with Case No. 4
8	<i>Realtime Data LLC d/b/a IXO v. Thomson Reuters Corporation et al. (II)</i> , No. 6:10-cv-247 (E.D. Texas)	Consolidated with Case No. 2
9	<i>Realtime Data, LLC d/b/a IXO v. Morgan Stanley, et al. (II)</i> , No. 6:10-cv-248 (E.D. Texas)	Consolidated with Case No. 3
10	<i>Realtime Data, LLC d/b/a IXO v. MetroPCS Texas, LLC et al.</i> , No. 6:10-cv-00493 (E.D. Texas)	Appeal Terminated
11	<i>Realtime Data, LLC d/b/a IXO v. Microsoft Corporation, et al.</i> , No. 4:14-cv-00827 (E.D. Texas)	Dismissed May 1, 2015
12	<i>Realtime Data, LLC d/b/a IXO v. Actian Corporation, et al.</i> , No. 6:15-cv-00463 (E.D. Texas)	Amended Complaints for Patent Infringement filed September 14, 2015
13	<i>Realtime Data, LLC d/b/a IXO v. Dropbox, Inc.</i> , No. 6:15-cv-00465 (E.D. Texas)	Transferred to the Northern District of California, January 16, 2016; Answer to Amended Complaint filed February 4, 2016
14	<i>Realtime Data, LLC d/b/a IXO v. Echostar Corporation, et al.</i> , No. 6:15-cv-00466 (E.D. Texas)	Consolidated with Case No. 12; Answer to Amended Complaint filed February 4, 2016
15	<i>Realtime Data, LLC d/b/a IXO v. Riverbed Technology, Inc., et al.</i> , No. 6:15-cv-00468 (E.D. Texas)	Consolidated with Case No. 12; Second Amended Complaint for Infringement filed February 2, 2016
16	<i>Realtime Data, LLC d/b/a IXO v. BMC Software, Inc.</i> , No. 6:15-cv-00464 (E.D. Texas)	Terminated October 5, 2015
17	<i>Realtime Data, LLC d/b/a IXO v. Oracle America, Inc., et al.</i> , No. 6:15-cv-00467 (E.D. Texas)	Consolidated with Case No. 12

18	<i>Realtime Data, LLC d/b/a IXO v. SAP America, Inc., et al.</i> , No. 6:15-cv-00469 (E.D. Texas)	Consolidated with Case No. 12; Answers to Amended Complaint filed February 4, 2016
19	<i>Realtime Data, LLC d/b/a IXO v. Teradata Corporation, et al.</i> , No. 6:15-cv-00470 (E.D. Texas)	Transferred to the Northern District of California, January 19, 2016
20	<i>Realtime Data, LLC d/b/a IXO v. Apple, Inc.</i> , No. 6:15-cv-00885 (E.D. Texas)	Order Granting Motion to Stay entered February 11, 2016
21	<i>Realtime Data LLC d/b/a IXO v. Hewlett Packard Enterprise Co., et al.</i> , No. 6:16-cv-00086 (E.D. Texas)	Complaint filed February 26, 2016
22	<i>Realtime Data LLC d/b/a IXO v. Oracle America, Inc.</i> , No. 6:16-cv-00088 (E.D. Texas)	Complaint filed February 26, 2016
23	<i>Realtime Data LLC d/b/a IXO v. CenturyLink, Inc., et al.</i> , No. 6:16-cv-00087 (E.D. Texas)	Complaint filed February 26, 2016
24	<i>Realtime Data LLC d/b/a IXO v. Dell, Inc., et al.</i> , No. 6:16-cv-00089 (E.D. Texas)	Complaint filed February 26, 2016

Updated court dockets for pending litigations are submitted herewith as documents **NPL19-NPL22**.

Information Disclosure Statement

Listed on accompanying IDS Forms PTO/SB/08a equivalent and PTO/SB/08b equivalent are documents that may be considered material to the patentability of this application as defined in 37 C.F.R. §1.56, and in compliance with the duty of disclosure requirements of 37 C.F.R. §§ 1.97 and 1.98.

Applicant has listed publication dates on the attached IDS Forms based on information presently available to the undersigned. However, the listed publication dates should not be construed as an admission that the information was actually published on the date indicated.

Atty. Dkt. No. 3421.005000C

Applicant reserves the right to establish the patentability of the claimed invention over any of the information provided herewith, and/or to prove that this information may not be prior art, and/or to prove that this information may not be enabling for the teachings purportedly offered.

This statement should not be construed as a representation that a search has been made, or that information more material to the examination of the present patent application does not exist. The Examiner is specifically requested not to rely solely on the material submitted herewith.

Filing under 37 C.F.R. § 1.97(c). This Information Disclosure Statement is being filed more than three months after the U.S. filing date AND after the mailing date of the first Office Action on the merits, but before the mailing date of a Final Rejection, or Notice of Allowance, or an action that otherwise closes prosecution in the application. The required fee is provided through online credit card payment authorization in the amount of \$180.00 in payment of the fee under 37 C.F.R. § 1.17(p).

A copy of document **NPL11** is submitted. However, in accordance with 37 C.F.R. § 1.98(a)(2)(ii), no copies of the U.S. patents cited as documents **US1-US4** on the attached IDS Forms are submitted.

Copies of documents **NPL1-NPL10** and **NPL12-NPL22** were cited by or submitted to the Office in an IDS that complies with 37 C.F.R. § 1.98(a)-(c) in Application No. 14/733,565, filed June 8, 2015 (now pending), which is relied upon for an earlier filing date under 35 U.S.C. § 120. Thus, copies of these documents are not attached. 37 C.F.R. § 1.98(d).

It is expected that the examiner will review the prosecution and cited art in the parent application nos. 14/733,565, filed June 8, 2015 (now pending); 14/577,286, filed December 19,

2014 (now abandoned); 14/134,933, filed December 19, 2013 (now U.S. Patent No. 8,929,442); 14/033,245, filed September 20, 2013 (now U.S. Patent No. 8,934,535); 13/154,239, filed June 6, 2011 (now U.S. Patent No. 8,553,759); 12/123,081, filed May 19, 2008 (now U.S. Patent No. 8,073,047); and 10/076,013, filed February 13, 2002 (now U.S. Patent No. 7,386,046), in accordance with MPEP 2001.06(b), and indicate in the next communication from the office that the art cited in the earlier prosecution history has been reviewed in connection with the present application.

Applicant submits herewith an Office Action from the co-pending U.S. Patent Application No.:

Document **NPL11** is a copy of a Notice of Allowance mailed March 25, 2016 in the prosecution of co-pending, commonly-assigned U.S. Patent Application No. 14/733,565.

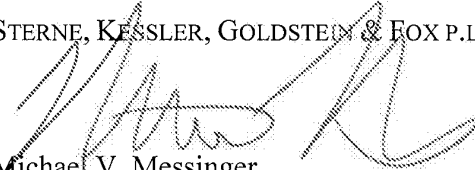
The identification of this Office Action is not to be construed as a waiver of secrecy as to that application now or upon issuance of the present application as a patent. The Examiner is respectfully requested to consider the cited application and the art cited therein during examination.

It is respectfully requested that the Examiner initial and return a copy of the enclosed IDS Forms, and indicate in the official file wrapper of this patent application that the documents have been considered.

The U.S. Patent and Trademark Office is hereby authorized to charge any fee deficiency, or credit any overpayment, to our Deposit Account No. 19-0036.

Respectfully submitted,

STERNE, KESSLER, GOLDSTEIN & FOX P.L.L.C.

  
Michael V. Messinger  
Attorney for Applicant  
Registration No. 37,575

Date: April 12, 2016

1100 New York Avenue, N.W.  
Washington, D.C. 20005-3934  
(202) 371-2600

2792811\_1.DOCX





Substitute for form 1449/PTO		<b>Complete if Known</b>	
<b>FIFTH SUPPLEMENTAL INFORMATION DISCLOSURE STATEMENT BY APPLICANT</b> <i>(Use as many sheets as necessary)</i>		Application Number	14/876,276
		Filing Date	October 6, 2015
		First Named Inventor	James J. FALLON
		Art Unit	2634
		Examiner Name	BOCURE, TESFALDET
		Attorney Docket Number	3421.005000C
Sheet	1	of	3

<b>NON PATENT LITERATURE DOCUMENTS</b>			
Examiner Initials*	Cite No. <sup>1</sup>	Include name of the author (in CAPITAL LETTERS), title of the article (when appropriate), title of the item (book, magazine, journal, serial, symposium, catalog, etc.), date, page(s), volume-issue number(s), publisher, city and/or country where published	T <sup>2</sup>
	NPL1	Dell Inc.'s Answer, Defenses, and Counterclaims to Plaintiff's Second Amended Complaint, filed in Realtime Data, LLC d/b/a IXO v. Actian Corporation, et al., Case No. 6:15-cv-00463-RWS-JDL (E.D. Tex.), filed February 19, 2016; 18 pages.	
	NPL2	Riverbed Technology's Answer, Defenses, and Counterclaims, filed in Realtime Data, LLC d/b/a IXO v. Actian Corporation, et al., Case No. 6:15-cv-00463-RWS-JDL (E.D. Tex.), filed February 19, 2016; 26 pages.	
	NPL3	Complaint for Patent Infringement Against Dell Inc., EMC Corporation, iland Internet Solutions Corporation, and Veeam Software Corporation, filed in Realtime Data d/b/a IXO v. Dell Inc., et al., Case No. 6:16-cv-00089 (E.D. Texas), filed February 26, 2016; 67 pages.	
	NPL4	Complaint for Patent Infringement Against Hewlett Packard Enterprise Co., HP Enterprise Services, LLC, and Silver Peak Systems, Inc., filed in Realtime Data d/b/a IXO v. Hewlett Packard Enterprise, Co., et al., Case No. 6:16-cv-00086 (E.D. Texas), filed February 26, 2016; 49 pages.	
	NPL5	Complaint for Patent Infringement Against CenturyLink, Inc. and Veritas Technologies LLC, filed in Realtime Data d/b/a IXO v. CenturyLink, Inc., et al., Case No. 6:16-cv-00087 (E.D. Texas), filed February 26, 2016; 46 pages.	
	NPL6	Complaint for Patent Infringement Against Oracle America, Inc., filed in Realtime Data d/b/a IXO v. Oracle America, Inc., Case No. 6:16-cv-00088 (E.D. Texas), filed February 26, 2016; 40 pages.	
	NPL7	Realtime Data LLC d/b/a IXO's Answer to Echostar Corporation's and Hughes Network Systems, LLC's Counterclaims, filed Realtime Data LLC d/b/a IXO v. Actian Corporation, et al., Case No. 6:15-cv-000463-RWS-JDL (E.D. Texas), filed February 25, 2016; 8 pages.	
	NPL8	Realtime Data LLC d/b/a IXO's Answer to SAP America Inc.'s and Sybase, Inc.'s Counterclaims, filed Realtime Data LLC d/b/a IXO v. Actian Corporation, et al., Case No. 6:15-cv-000463-RWS-JDL (E.D. Texas), filed February 25, 2016; 5 pages.	
	NPL9	Realtime Data LLC d/b/a IXO's Answer to Dell, Inc.'s Counterclaims, filed Realtime Data LLC d/b/a IXO v. Actian Corporation, et al., Case No. 6:15-cv-000463-RWS-JDL (E.D. Texas), filed February 25, 2016; 5 pages.	
	NPL10	Copy of Non-Final Office Action for U.S. Appl. No.14/853,581, mailed March 15, 2016; 5 pages.	

Examiner Signature	Date Considered
-----------------------	--------------------

\*EXAMINER: Initial if reference considered, whether or not citation is in conformance with MPEP 609. Draw line through citation if not in conformance and not considered. Include copy of this form with next communication to applicant.

<sup>1</sup> Applicant's unique citation designation number (optional). <sup>2</sup> Applicant is to place a check mark here if English language Translation is attached.

Substitute for form 1449/PTO		<b>Complete if Known</b>	
<b>FIFTH SUPPLEMENTAL INFORMATION DISCLOSURE STATEMENT BY APPLICANT</b> <i>(Use as many sheets as necessary)</i>		Application Number	14/876,276
		Filing Date	October 6, 2015
		First Named Inventor	James J. FALLON
		Art Unit	2634
		Examiner Name	BOCURE, TESFALDET
		Attorney Docket Number	3421.005000C
Sheet	2	of	3

NON PATENT LITERATURE DOCUMENTS			
Examiner Initials*	Cite No. <sup>1</sup>	Include name of the author (in CAPITAL LETTERS), title of the article (when appropriate), title of the item (book, magazine, journal, serial, symposium, catalog, etc.), date, page(s), volume number, publisher, city and/or country where published	T <sup>2</sup>
	NPL11	Copy of Notice of Allowance for U.S. Patent Appl. No. 14/733,565, mailed March 25, 2016; 8 pages.	
	NPL12	Petition for Inter Partes Review of Claims 1-4, 8, 14-17, 21 and 28 of U.S. Patent No. 6,597,812, filed in SAP America Inc., et al. v. Realtime Data, LLC d/b/a IXO, Case No. IPR2016-00783 (P.T.A.B.), filed April 1, 2016; 67 pages.	
	NPL13	Declaration of Scott Bennett, Ph.D., filed in SAP America Inc., et al. v. Realtime Data LLC d/b/a IXO, Case No. IPR2016-00783 (P.T.A.B.), filed April 1, 2016; 45 pages.	
	NPL14	Declaration of Charles D. Creusere in Support of Petition for Inter Partes Review of Claims 1-4, 8, 14-17, 21 and 28 of U.S. Patent No. 6,597,812, filed in SAP America Inc., et al. v. Realtime Data LLC d/b/a IXO, Case No. IPR2016-00783 (P.T.A.B.), filed April 1, 2016; 82 pages.	
	NPL15	NELSON, M., The Data Compression Book, 1st Edition, San Mateo, CA: M&T Books, 1992; 534 pages.	
	NPL16	RANDELL, B., "Hardware/Software Tradeoffs: A General Design Principle?", Computing Laboratory, The University of Newcastle Upon Tyne, January 25, 1985; 2 pages.	
	NPL17	Definition of "consecutive", Random House Webster's College Dictionary, 2nd Edition, New York: Random House, 1998; p. 281.	
	NPL18	ROBINSON, et al., "Results of a Prototype Television Bandwidth Compression Scheme," Proceedings of the IEEE, Vol. 55, No. 3, March 1967; pp. 356-364.	
	NPL19	Court Docket History for Realtime Data LLC d/b/a IXO v. Hewlett Packard Enterprise Co., et al., No. 6:16-cv-00086 (E.D. Texas), downloaded March 1, 2016, 2 pages.	
	NPL20	Court Docket History for Realtime Data LLC d/b/a IXO v. Oracle America, Inc., No. 6:16-cv-00088 (E.D. Texas), downloaded March 1, 2016; 2 pages.	

Examiner Signature	Date Considered
--------------------	-----------------

\*EXAMINER: Initial if reference considered, whether or not citation is in conformance with MPEP 609. Draw line through citation if not in conformance and not considered. Include copy of this form with next communication to applicant.

<sup>1</sup> Applicant's unique citation designation number (optional). <sup>2</sup> Applicant is to place a check mark here if English language Translation is attached.



## Electronic Patent Application Fee Transmittal

<b>Application Number:</b>	14876276			
<b>Filing Date:</b>	06-Oct-2015			
<b>Title of Invention:</b>	Video Data Compression Systems			
<b>First Named Inventor/Applicant Name:</b>	James J. FALLON			
<b>Filer:</b>	Michael V. Messinger/William Flanigen			
<b>Attorney Docket Number:</b>	3421.005000C			
Filed as Large Entity				
<b>Filing Fees for Utility under 35 USC 111(a)</b>				
<b>Description</b>	<b>Fee Code</b>	<b>Quantity</b>	<b>Amount</b>	<b>Sub-Total in USD(\$)</b>
<b>Basic Filing:</b>				
<b>Pages:</b>				
<b>Claims:</b>				
<b>Miscellaneous-Filing:</b>				
<b>Petition:</b>				
<b>Patent-Appeals-and-Interference:</b>				
<b>Post-Allowance-and-Post-Issuance:</b>				
<b>Extension-of-Time:</b>				

Description	Fee Code	Quantity	Amount	Sub-Total in USD(\$)
<b>Miscellaneous:</b>				
Submission- Information Disclosure Stmt	1806	1	180	180
<b>Total in USD (\$)</b>				<b>180</b>

## Electronic Acknowledgement Receipt

<b>EFS ID:</b>	25471402
<b>Application Number:</b>	14876276
<b>International Application Number:</b>	
<b>Confirmation Number:</b>	3403
<b>Title of Invention:</b>	Video Data Compression Systems
<b>First Named Inventor/Applicant Name:</b>	James J. FALLON
<b>Customer Number:</b>	26111
<b>Filer:</b>	Michael V. Messinger/William Flanigen
<b>Filer Authorized By:</b>	Michael V. Messinger
<b>Attorney Docket Number:</b>	3421.005000C
<b>Receipt Date:</b>	12-APR-2016
<b>Filing Date:</b>	06-OCT-2015
<b>Time Stamp:</b>	20:42:45
<b>Application Type:</b>	Utility under 35 USC 111(a)

### Payment information:

Submitted with Payment	yes
Payment Type	Credit Card
Payment was successfully received in RAM	\$180
RAM confirmation Number	5884
Deposit Account	
Authorized User	

The Director of the USPTO is hereby authorized to charge indicated fees and credit any overpayment as follows:

<b>File Listing:</b>					
<b>Document Number</b>	<b>Document Description</b>	<b>File Name</b>	<b>File Size(Bytes)/ Message Digest</b>	<b>Multi Part /.zip</b>	<b>Pages (if appl.)</b>
1		3421005000C_5SIDS.pdf	3266514 3e9173c8ea977fb5b192cc859923dad2273cf972	yes	27
<b>Multipart Description/PDF files in .zip description</b>					
	<b>Document Description</b>		<b>Start</b>	<b>End</b>	
	Miscellaneous Incoming Letter		1	2	
	Amendment/Req. Reconsideration-After Non-Final Reject		3	3	
	Claims		4	10	
	Abstract		11	11	
	Applicant Arguments/Remarks Made in an Amendment		12	14	
	Transmittal Letter		15	23	
	Information Disclosure Statement (IDS) Form (SB08)		24	27	
<b>Warnings:</b>					
<b>Information:</b>					
2	Non Patent Literature	NPL11_NOA_14733565_03252016.pdf	424910 72bf51aa73ba3e6bad68be339876334c07acfe1	no	8
<b>Warnings:</b>					
<b>Information:</b>					
3	Fee Worksheet (SB06)	fee-info.pdf	30302 b971bd71861ccba8de5b3223436bd12654e24569	no	2
<b>Warnings:</b>					
<b>Information:</b>					
<b>Total Files Size (in bytes):</b>			3721726		



**This Acknowledgement Receipt evidences receipt on the noted date by the USPTO of the indicated documents, characterized by the applicant, and including page counts, where applicable. It serves as evidence of receipt similar to a Post Card, as described in MPEP 503.**

**New Applications Under 35 U.S.C. 111**

**If a new application is being filed and the application includes the necessary components for a filing date (see 37 CFR 1.53(b)-(d) and MPEP 506), a Filing Receipt (37 CFR 1.54) will be issued in due course and the date shown on this Acknowledgement Receipt will establish the filing date of the application.**

**National Stage of an International Application under 35 U.S.C. 371**

**If a timely submission to enter the national stage of an international application is compliant with the conditions of 35 U.S.C. 371 and other applicable requirements a Form PCT/DO/EO/903 indicating acceptance of the application as a national stage submission under 35 U.S.C. 371 will be issued in addition to the Filing Receipt, in due course.**

**New International Application Filed with the USPTO as a Receiving Office**

**If a new international application is being filed and the international application includes the necessary components for an international filing date (see PCT Article 11 and MPEP 1810), a Notification of the International Application Number and of the International Filing Date (Form PCT/RO/105) will be issued in due course, subject to prescriptions concerning national security, and the date shown on this Acknowledgement Receipt will establish the international filing date of the application.**

MICHAEL V. MESSINGER  
DIRECTOR  
(202) 772-8667  
MIKEM@SKGF.COM



April 12, 2016

Commissioner for Patents  
PO Box 1450  
Alexandria, VA 22313-1450

**Confirmation No. 3403**  
**Art Unit 2634**  
**Attn: Mail Stop Amendment**

Re: U.S. Utility Patent Application  
Application No. 14/876,276; Filing Date: October 6, 2015  
For: **Video Data Compression Systems**  
Inventors: FALLON *et al.*  
Our Ref: 3421.005000C

Commissioner:

Transmitted herewith for appropriate action are the following documents:

1. Online Credit Card Payment Authorization in the amount of \$180.00 in payment of the fee under 37 C.F.R. § 1.17(p);
2. Amendment and Reply Under 37 C.F.R. §1.111;
3. Fifth Supplemental Information Disclosure Statement;
4. Form PTO/SB/08a (1 sheet) listing 4 documents (**US1-US4**);
5. Form PTO/SB/08b (3 sheets) listing 22 documents (**NPL1-NPL22**); and
6. A copy of the cited document (**NPL11**).

***The above-listed documents are filed electronically through EFS-Web.***

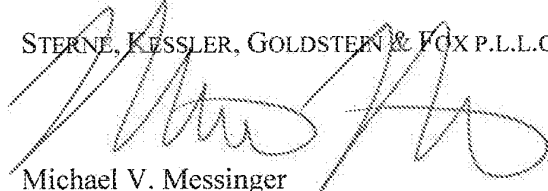
In the event that extensions of time are necessary to prevent abandonment of this patent application, then such extensions of time are hereby petitioned.

Commissioner for Patents  
April 12, 2016  
Page 2

Fee payment is provided through online credit card payment. The U.S. Patent and Trademark Office is hereby authorized to charge any fee deficiency, or credit any overpayment, to our Deposit Account No. 19-0036.

Respectfully submitted,

STERNE, KESSLER, GOLDSTEIN & FOX P.L.L.C.



Michael V. Messinger  
Attorney for Applicant  
Registration No. 37,575

MVM/MRM/wcf  
Enclosures

2792822\_1.DOCX

Under the Paperwork Reduction Act of 1995, no persons are required to respond to a collection of information unless it displays a valid OMB control number.

<b>PATENT APPLICATION FEE DETERMINATION RECORD</b> Substitute for Form PTO-875	Application or Docket Number 14/876,276	Filing Date 10/06/2015	<input type="checkbox"/> To be Mailed
---	--	---------------------------	---------------------------------------

ENTITY:  LARGE  SMALL  MICRO

**APPLICATION AS FILED – PART I**

FOR	NUMBER FILED	NUMBER EXTRA	RATE (\$)	FEE (\$)
<input type="checkbox"/> BASIC FEE (37 CFR 1.16(a), (b), or (c))	N/A	N/A	N/A	
<input type="checkbox"/> SEARCH FEE (37 CFR 1.16(k), (j), or (m))	N/A	N/A	N/A	
<input type="checkbox"/> EXAMINATION FEE (37 CFR 1.16(o), (p), or (q))	N/A	N/A	N/A	
TOTAL CLAIMS (37 CFR 1.16(i))	minus 20 =	*	X \$ =	
INDEPENDENT CLAIMS (37 CFR 1.16(h))	minus 3 =	*	X \$ =	
<input type="checkbox"/> APPLICATION SIZE FEE (37 CFR 1.16(s))	If the specification and drawings exceed 100 sheets of paper, the application size fee due is \$310 (\$155 for small entity) for each additional 50 sheets or fraction thereof. See 35 U.S.C. 41(a)(1)(G) and 37 CFR 1.16(s).			
<input type="checkbox"/> MULTIPLE DEPENDENT CLAIM PRESENT (37 CFR 1.16(j))				
* If the difference in column 1 is less than zero, enter "0" in column 2.			TOTAL	

**APPLICATION AS AMENDED – PART II**

	(Column 1)	(Column 2)	(Column 3)	PRESENT EXTRA	RATE (\$)	ADDITIONAL FEE (\$)
<b>AMENDMENT</b>	<b>04/12/2016</b>	CLAIMS REMAINING AFTER AMENDMENT	HIGHEST NUMBER PREVIOUSLY PAID FOR			
	Total (37 CFR 1.16(i))	* 30	Minus ** 30	= 0	x \$80 =	0
	Independent (37 CFR 1.16(h))	* 2	Minus *** 3	= 0	x \$420 =	0
	<input type="checkbox"/> Application Size Fee (37 CFR 1.16(s))					
<input type="checkbox"/> FIRST PRESENTATION OF MULTIPLE DEPENDENT CLAIM (37 CFR 1.16(j))						
					TOTAL ADD'L FEE	<b>0</b>

	(Column 1)	(Column 2)	(Column 3)	PRESENT EXTRA	RATE (\$)	ADDITIONAL FEE (\$)
<b>AMENDMENT</b>		CLAIMS REMAINING AFTER AMENDMENT	HIGHEST NUMBER PREVIOUSLY PAID FOR			
	Total (37 CFR 1.16(i))	*	Minus **	=	X \$ =	
	Independent (37 CFR 1.16(h))	*	Minus ***	=	X \$ =	
	<input type="checkbox"/> Application Size Fee (37 CFR 1.16(s))					
<input type="checkbox"/> FIRST PRESENTATION OF MULTIPLE DEPENDENT CLAIM (37 CFR 1.16(j))						
					TOTAL ADD'L FEE	

\* If the entry in column 1 is less than the entry in column 2, write "0" in column 3.  
 \*\* If the "Highest Number Previously Paid For" IN THIS SPACE is less than 20, enter "20".  
 \*\*\* If the "Highest Number Previously Paid For" IN THIS SPACE is less than 3, enter "3".  
 The "Highest Number Previously Paid For" (Total or Independent) is the highest number found in the appropriate box in column 1.

LIE  
/DOROTHY BELL/

This collection of information is required by 37 CFR 1.16. The information is required to obtain or retain a benefit by the public which is to file (and by the USPTO to process) an application. Confidentiality is governed by 35 U.S.C. 122 and 37 CFR 1.14. This collection is estimated to take 12 minutes to complete, including gathering, preparing, and submitting the completed application form to the USPTO. Time will vary depending upon the individual case. Any comments on the amount of time you require to complete this form and/or suggestions for reducing this burden, should be sent to the Chief Information Officer, U.S. Patent and Trademark Office, U.S. Department of Commerce, P.O. Box 1450, Alexandria, VA 22313-1450. DO NOT SEND FEES OR COMPLETED FORMS TO THIS ADDRESS. **SEND TO: Commissioner for Patents, P.O. Box 1450, Alexandria, VA 22313-1450.**

If you need assistance in completing the form, call 1-800-PTO-9199 and select option 2.



UNITED STATES PATENT AND TRADEMARK OFFICE

UNITED STATES DEPARTMENT OF COMMERCE
United States Patent and Trademark Office
Address: COMMISSIONER FOR PATENTS
P.O. Box 1450
Alexandria, Virginia 22313-1450
www.uspto.gov

NOTICE OF ALLOWANCE AND FEE(S) DUE

26111 7590 04/26/2016
STERNE, KESSLER, GOLDSTEIN & FOX P.L.L.C.
1100 NEW YORK AVENUE, N.W.
WASHINGTON, DC 20005

EXAMINER

BOCURE, TESFALDET

ART UNIT PAPER NUMBER

2634

DATE MAILED: 04/26/2016

Table with 5 columns: APPLICATION NO., FILING DATE, FIRST NAMED INVENTOR, ATTORNEY DOCKET NO., CONFIRMATION NO.
14/876,276 10/06/2015 James J. FALLON 3421.005000C 3403

TITLE OF INVENTION: Video Data Compression Systems

Table with 7 columns: APPLN. TYPE, ENTITY STATUS, ISSUE FEE DUE, PUBLICATION FEE DUE, PREV. PAID ISSUE FEE, TOTAL FEE(S) DUE, DATE DUE
nonprovisional UNDISCOUNTED \$960 \$0 \$0 \$960 07/26/2016

THE APPLICATION IDENTIFIED ABOVE HAS BEEN EXAMINED AND IS ALLOWED FOR ISSUANCE AS A PATENT. PROSECUTION ON THE MERITS IS CLOSED. THIS NOTICE OF ALLOWANCE IS NOT A GRANT OF PATENT RIGHTS. THIS APPLICATION IS SUBJECT TO WITHDRAWAL FROM ISSUE AT THE INITIATIVE OF THE OFFICE OR UPON PETITION BY THE APPLICANT. SEE 37 CFR 1.313 AND MPEP 1308.

THE ISSUE FEE AND PUBLICATION FEE (IF REQUIRED) MUST BE PAID WITHIN THREE MONTHS FROM THE MAILING DATE OF THIS NOTICE OR THIS APPLICATION SHALL BE REGARDED AS ABANDONED. THIS STATUTORY PERIOD CANNOT BE EXTENDED. SEE 35 U.S.C. 151. THE ISSUE FEE DUE INDICATED ABOVE DOES NOT REFLECT A CREDIT FOR ANY PREVIOUSLY PAID ISSUE FEE IN THIS APPLICATION. IF AN ISSUE FEE HAS PREVIOUSLY BEEN PAID IN THIS APPLICATION (AS SHOWN ABOVE), THE RETURN OF PART B OF THIS FORM WILL BE CONSIDERED A REQUEST TO REAPPLY THE PREVIOUSLY PAID ISSUE FEE TOWARD THE ISSUE FEE NOW DUE.

HOW TO REPLY TO THIS NOTICE:

I. Review the ENTITY STATUS shown above. If the ENTITY STATUS is shown as SMALL or MICRO, verify whether entitlement to that entity status still applies.

If the ENTITY STATUS is the same as shown above, pay the TOTAL FEE(S) DUE shown above.

If the ENTITY STATUS is changed from that shown above, on PART B - FEE(S) TRANSMITTAL, complete section number 5 titled "Change in Entity Status (from status indicated above)".

For purposes of this notice, small entity fees are 1/2 the amount of undiscounted fees, and micro entity fees are 1/2 the amount of small entity fees.

II. PART B - FEE(S) TRANSMITTAL, or its equivalent, must be completed and returned to the United States Patent and Trademark Office (USPTO) with your ISSUE FEE and PUBLICATION FEE (if required). If you are charging the fee(s) to your deposit account, section "4b" of Part B - Fee(s) Transmittal should be completed and an extra copy of the form should be submitted. If an equivalent of Part B is filed, a request to reapply a previously paid issue fee must be clearly made, and delays in processing may occur due to the difficulty in recognizing the paper as an equivalent of Part B.

III. All communications regarding this application must give the application number. Please direct all communications prior to issuance to Mail Stop ISSUE FEE unless advised to the contrary.

IMPORTANT REMINDER: Utility patents issuing on applications filed on or after Dec. 12, 1980 may require payment of maintenance fees. It is patentee's responsibility to ensure timely payment of maintenance fees when due.





UNITED STATES PATENT AND TRADEMARK OFFICE

UNITED STATES DEPARTMENT OF COMMERCE
United States Patent and Trademark Office
Address: COMMISSIONER FOR PATENTS
P.O. Box 1450
Alexandria, Virginia 22313-1450
www.uspto.gov

Table with 5 columns: APPLICATION NO., FILING DATE, FIRST NAMED INVENTOR, ATTORNEY DOCKET NO., CONFIRMATION NO.
14/876,276 10/06/2015 James J. FALLON 3421.005000C 3403

26111 7590 04/26/2016
STERNE, KESSLER, GOLDSTEIN & FOX P.L.L.C.
1100 NEW YORK AVENUE, N.W.
WASHINGTON, DC 20005

EXAMINER

BOCURE, TESFALDET

ART UNIT PAPER NUMBER

2634

DATE MAILED: 04/26/2016

Determination of Patent Term Adjustment under 35 U.S.C. 154 (b)
(Applications filed on or after May 29, 2000)

The Office has discontinued providing a Patent Term Adjustment (PTA) calculation with the Notice of Allowance.

Section 1(h)(2) of the AIA Technical Corrections Act amended 35 U.S.C. 154(b)(3)(B)(i) to eliminate the requirement that the Office provide a patent term adjustment determination with the notice of allowance. See Revisions to Patent Term Adjustment, 78 Fed. Reg. 19416, 19417 (Apr. 1, 2013). Therefore, the Office is no longer providing an initial patent term adjustment determination with the notice of allowance. The Office will continue to provide a patent term adjustment determination with the Issue Notification Letter that is mailed to applicant approximately three weeks prior to the issue date of the patent, and will include the patent term adjustment on the patent. Any request for reconsideration of the patent term adjustment determination (or reinstatement of patent term adjustment) should follow the process outlined in 37 CFR 1.705.

Any questions regarding the Patent Term Extension or Adjustment determination should be directed to the Office of Patent Legal Administration at (571)-272-7702. Questions relating to issue and publication fee payments should be directed to the Customer Service Center of the Office of Patent Publication at 1-(888)-786-0101 or (571)-272-4200.

## OMB Clearance and PRA Burden Statement for PTOL-85 Part B

The Paperwork Reduction Act (PRA) of 1995 requires Federal agencies to obtain Office of Management and Budget approval before requesting most types of information from the public. When OMB approves an agency request to collect information from the public, OMB (i) provides a valid OMB Control Number and expiration date for the agency to display on the instrument that will be used to collect the information and (ii) requires the agency to inform the public about the OMB Control Number's legal significance in accordance with 5 CFR 1320.5(b).

The information collected by PTOL-85 Part B is required by 37 CFR 1.311. The information is required to obtain or retain a benefit by the public which is to file (and by the USPTO to process) an application. Confidentiality is governed by 35 U.S.C. 122 and 37 CFR 1.14. This collection is estimated to take 12 minutes to complete, including gathering, preparing, and submitting the completed application form to the USPTO. Time will vary depending upon the individual case. Any comments on the amount of time you require to complete this form and/or suggestions for reducing this burden, should be sent to the Chief Information Officer, U.S. Patent and Trademark Office, U.S. Department of Commerce, P.O. Box 1450, Alexandria, Virginia 22313-1450. DO NOT SEND FEES OR COMPLETED FORMS TO THIS ADDRESS. SEND TO: Commissioner for Patents, P.O. Box 1450, Alexandria, Virginia 22313-1450. Under the Paperwork Reduction Act of 1995, no persons are required to respond to a collection of information unless it displays a valid OMB control number.

### Privacy Act Statement

**The Privacy Act of 1974 (P.L. 93-579)** requires that you be given certain information in connection with your submission of the attached form related to a patent application or patent. Accordingly, pursuant to the requirements of the Act, please be advised that: (1) the general authority for the collection of this information is 35 U.S.C. 2(b)(2); (2) furnishing of the information solicited is voluntary; and (3) the principal purpose for which the information is used by the U.S. Patent and Trademark Office is to process and/or examine your submission related to a patent application or patent. If you do not furnish the requested information, the U.S. Patent and Trademark Office may not be able to process and/or examine your submission, which may result in termination of proceedings or abandonment of the application or expiration of the patent.

The information provided by you in this form will be subject to the following routine uses:

1. The information on this form will be treated confidentially to the extent allowed under the Freedom of Information Act (5 U.S.C. 552) and the Privacy Act (5 U.S.C. 552a). Records from this system of records may be disclosed to the Department of Justice to determine whether disclosure of these records is required by the Freedom of Information Act.
2. A record from this system of records may be disclosed, as a routine use, in the course of presenting evidence to a court, magistrate, or administrative tribunal, including disclosures to opposing counsel in the course of settlement negotiations.
3. A record in this system of records may be disclosed, as a routine use, to a Member of Congress submitting a request involving an individual, to whom the record pertains, when the individual has requested assistance from the Member with respect to the subject matter of the record.
4. A record in this system of records may be disclosed, as a routine use, to a contractor of the Agency having need for the information in order to perform a contract. Recipients of information shall be required to comply with the requirements of the Privacy Act of 1974, as amended, pursuant to 5 U.S.C. 552a(m).
5. A record related to an International Application filed under the Patent Cooperation Treaty in this system of records may be disclosed, as a routine use, to the International Bureau of the World Intellectual Property Organization, pursuant to the Patent Cooperation Treaty.
6. A record in this system of records may be disclosed, as a routine use, to another federal agency for purposes of National Security review (35 U.S.C. 181) and for review pursuant to the Atomic Energy Act (42 U.S.C. 218(c)).
7. A record from this system of records may be disclosed, as a routine use, to the Administrator, General Services, or his/her designee, during an inspection of records conducted by GSA as part of that agency's responsibility to recommend improvements in records management practices and programs, under authority of 44 U.S.C. 2904 and 2906. Such disclosure shall be made in accordance with the GSA regulations governing inspection of records for this purpose, and any other relevant (i.e., GSA or Commerce) directive. Such disclosure shall not be used to make determinations about individuals.
8. A record from this system of records may be disclosed, as a routine use, to the public after either publication of the application pursuant to 35 U.S.C. 122(b) or issuance of a patent pursuant to 35 U.S.C. 151. Further, a record may be disclosed, subject to the limitations of 37 CFR 1.14, as a routine use, to the public if the record was filed in an application which became abandoned or in which the proceedings were terminated and which application is referenced by either a published application, an application open to public inspection or an issued patent.
9. A record from this system of records may be disclosed, as a routine use, to a Federal, State, or local law enforcement agency, if the USPTO becomes aware of a violation or potential violation of law or regulation.



<b>Notice of Allowability</b>	<b>Application No.</b> 14/876,276	<b>Applicant(s)</b> FALLON ET AL.	
	<b>Examiner</b> TESFALDET BOCURE	<b>Art Unit</b> 2634	<b>AIA (First Inventor to File) Status</b> No

**-- The MAILING DATE of this communication appears on the cover sheet with the correspondence address--**

All claims being allowable, PROSECUTION ON THE MERITS IS (OR REMAINS) CLOSED in this application. If not included herewith (or previously mailed), a Notice of Allowance (PTOL-85) or other appropriate communication will be mailed in due course. **THIS NOTICE OF ALLOWABILITY IS NOT A GRANT OF PATENT RIGHTS.** This application is subject to withdrawal from issue at the initiative of the Office or upon petition by the applicant. See 37 CFR 1.313 and MPEP 1308.

1.  This communication is responsive to 04/12/2016.  
 A declaration(s)/affidavit(s) under **37 CFR 1.130(b)** was/were filed on \_\_\_\_\_.
2.  An election was made by the applicant in response to a restriction requirement set forth during the interview on \_\_\_\_\_; the restriction requirement and election have been incorporated into this action.
3.  The allowed claim(s) is/are 1-30. As a result of the allowed claim(s), you may be eligible to benefit from the **Patent Prosecution Highway** program at a participating intellectual property office for the corresponding application. For more information, please see [http://www.uspto.gov/patents/init\\_events/pph/index.jsp](http://www.uspto.gov/patents/init_events/pph/index.jsp) or send an inquiry to [PPHfeedback@uspto.gov](mailto:PPHfeedback@uspto.gov).
4.  Acknowledgment is made of a claim for foreign priority under 35 U.S.C. § 119(a)-(d) or (f).

**Certified copies:**

a)  All    b)  Some    \*c)  None of the:

1.  Certified copies of the priority documents have been received.
2.  Certified copies of the priority documents have been received in Application No. \_\_\_\_\_.
3.  Copies of the certified copies of the priority documents have been received in this national stage application from the International Bureau (PCT Rule 17.2(a)).

\* Certified copies not received: \_\_\_\_\_.

Applicant has THREE MONTHS FROM THE "MAILING DATE" of this communication to file a reply complying with the requirements noted below. Failure to timely comply will result in ABANDONMENT of this application. **THIS THREE-MONTH PERIOD IS NOT EXTENDABLE.**

5.  CORRECTED DRAWINGS ( as "replacement sheets") must be submitted.  
 including changes required by the attached Examiner's Amendment / Comment or in the Office action of Paper No./Mail Date \_\_\_\_\_.  
**Identifying indicia such as the application number (see 37 CFR 1.84(c)) should be written on the drawings in the front (not the back) of each sheet. Replacement sheet(s) should be labeled as such in the header according to 37 CFR 1.121(d).**
6.  DEPOSIT OF and/or INFORMATION about the deposit of BIOLOGICAL MATERIAL must be submitted. Note the attached Examiner's comment regarding REQUIREMENT FOR THE DEPOSIT OF BIOLOGICAL MATERIAL.

**Attachment(s)**

- |  |   |
|--|---|
| 1. <input type="checkbox"/> Notice of References Cited (PTO-892)   | 5. <input checked="" type="checkbox"/> Examiner's Amendment/Comment       |
| 2. <input checked="" type="checkbox"/> Information Disclosure Statements (PTO/SB/08),<br>Paper No./Mail Date <u>2/1/16, 2/24/16 &amp; 4/2/16</u> | 6. <input type="checkbox"/> Examiner's Statement of Reasons for Allowance |
| 3. <input type="checkbox"/> Examiner's Comment Regarding Requirement for Deposit<br>of Biological Material                                       | 7. <input type="checkbox"/> Other _____.                                  |
| 4. <input type="checkbox"/> Interview Summary (PTO-413),<br>Paper No./Mail Date _____.   |   |

/TESFALDET BOCURE/  
Primary Examiner, Art Unit 2634

### **DETAILED ACTION**

1. The present application is being examined under the pre-AIA first to invent provisions.
2. This office action (Notice of Allowance) is in response to the amendment and remarks filed on 04/12/2016. The pending claims 1-30 are now allowed.

### ***Information Disclosure Statement***

3. The information disclosure statements (IDSs) submitted on 02/01/2016, 02/24/2016 and 04/12/2016 are in compliance with the provisions of 37 CFR 1.97. Accordingly, the information disclosure statement is being considered by the examiner. Attached with this correspondence are the initialed copies of the IDSs.

### ***Response to Amendment***

4. In response to the amendment and remarks filed on 04/12/2016, the following actions have been taken:
  - The objection to the specification to update the status of the parent application indicated in the office action mailed on 01/28/2016 was neither addressed nor amended. However, the above minor informality has been corrected by the Examiner's amendment as shown below.
  - The abstract of the disclosure is withdrawn because of the preliminary amendment, which was overlooked by the Examiner and as indicated in the interview summary of 3/15/2016 and 03/21/2016. Further to the abstract of the

disclosure in the amendment of 04/12/2016 has been considered by the Examiner.

- The objection to claims 1-30 indicated in the office action mailed on 01/28/2016 has been withdrawn.
- The rejection to claims 1-30 under 112 second paragraph indicated in the office action mailed on 01/28/2016 has been withdrawn.

#### **EXAMINER'S AMENDMENT**

5. An examiner's amendment to the record appears below. Should the changes and/or additions be unacceptable to applicant, an amendment may be filed as provided by 37 CFR 1.312. To ensure consideration of such an amendment, it MUST be submitted no later than the payment of the issue fee.

The application has been amended as follows:

In the Specification:

In ¶ [0001], line 3, after "December 19, 2014," ---now abandoned,---has been added.

#### **Remarks:**

6. The above Examiner's Amendment was made to update the status of the parent application S/N 14/577,286.

**Conclusion**


7. Any inquiry concerning this communication or earlier communications from the examiner should be directed to TESHALDET BOCURE whose telephone number is (571)272-3015. The examiner can normally be reached on 8:30am-to-5:00pm.

If attempts to reach the examiner by telephone are unsuccessful, the examiner's supervisor, Daniel C. Washburn can be reached on 571-272-5551. The fax phone number for the organization where this application or proceeding is assigned is 571-273-8300.

Information regarding the status of an application may be obtained from the Patent Application Information Retrieval (PAIR) system. Status information for published applications may be obtained from either Private PAIR or Public PAIR. Status information for unpublished applications is available through Private PAIR only. For more information about the PAIR system, see <http://pair-direct.uspto.gov>. Should you have questions on access to the Private PAIR system, contact the Electronic Business Center (EBC) at 866-217-9197 (toll-free). If you would like assistance from a USPTO Customer Service Representative or access to the automated information system, call 800-786-9199 (IN USA OR CANADA) or 571-272-1000.

/TESHALDET BOCURE/  
Primary Examiner, Art Unit 2634

/T. B./  
Primary Examiner, Art Unit 2634

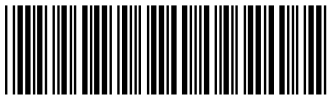
<b>Issue Classification</b> 	<b>Application/Control No.</b> 14876276	<b>Applicant(s)/Patent Under Reexamination</b> FALLON ET AL.	
	<b>Examiner</b> TESFALDET BOCURE	<b>Art Unit</b> 2634	

CPC					
Symbol				Type	Version
H04N	19		103	F	2014-11-01
H04N	19		164	I	2014-11-01
H04N	19		176	I	2014-11-01
H03M	7		30	I	2013-01-01
H03M	7		3084	I	2013-01-01
H03M	7		6094	I	2013-01-01

CPC Combination Sets				
Symbol	Type	Set	Ranking	Version

NONE		<b>Total Claims Allowed:</b>	
(Assistant Examiner)	(Date)	30	
/TESFALDET BOCURE/ Primary Examiner.Art Unit 2634	04/18/2016	O.G. Print Claim(s)	O.G. Print Figure
(Primary Examiner)	(Date)	1	1




<b>Issue Classification</b> 	<b>Application/Control No.</b> 14876276	<b>Applicant(s)/Patent Under Reexamination</b> FALLON ET AL.
	<b>Examiner</b> TESFALDET BOCURE	<b>Art Unit</b> 2634

**Claims renumbered in the same order as presented by applicant**
 **CPA**
 **T.D.**
 **R.1.47**

Final	Original	Final	Original	Final	Original	Final	Original	Final	Original	Final	Original	Final	Original	Final	Original
1	1	17	17												
2	2	18	18												
3	3	19	19												
4	4	20	20												
5	5	21	21												
6	6	22	22												
7	7	23	23												
8	8	24	24												
9	9	25	25												
10	10	26	26												
11	11	27	27												
12	12	28	28												
13	13	29	29												
14	14	30	30												
15	15														
16	16														

NONE		<b>Total Claims Allowed:</b>	
(Assistant Examiner)		30	
/TESFALDET BOCURE/ Primary Examiner. Art Unit 2634		04/18/2016	
(Primary Examiner)		O.G. Print Claim(s)	O.G. Print Figure
		1	1

<b>Search Notes</b>  	<b>Application/Control No.</b>  14876276	<b>Applicant(s)/Patent Under Reexamination</b>  FALLON ET AL.
	<b>Examiner</b>  TESFALDET BOCURE	<b>Art Unit</b>  2634

<b>CPC- SEARCHED</b>		
Symbol	Date	Examiner
((H03M7/30))   ((H03M7/3084))   ((H03M7/6094))   ((G06F15/7867))   ((G06T1/60))   ((H04N19/136).CPC.)	01/22/2016	TB
((H03M7/30))   ((H03M7/3059))   ((H03M7/3093))   ((H04L69/04))   ((H04N19/152))   ((H04N9/8042).CPC.)	01/22/2016	TB
( ( H03M7/30   H03M7/3059   H03M7/3084   H03M7/6094   H03M7/3088   H03M7/6023   H03M7/6064   H04N19/152   G11B20/00007 ).CPC.)	01/23/2016	TB
(H03M7/30 H03M7/3084 H03M7/6094 H04N19/164 H04N19/176 H04N19/103).CPC.	04/17/2016	TB
CPC Updated	04/18/2016	TB

<b>CPC COMBINATION SETS - SEARCHED</b>		
Symbol	Date	Examiner

<b>US CLASSIFICATION SEARCHED</b>			
Class	Subclass	Date	Examiner
375	240, 240.01, 240.02	01/22/2016	TB
341	50, 51, 126	01/22/2016	TB
375, 370, 348, 341, 711, 701, 381	Search ALL (\$8.ccls.)	01/22/2016	TB
375, 370, 348, 341, 711, 701, 381	Search Updated ALL	01/23/2016	TB
375, 370, 348, 341, 711, 701, 381	Search Updated ALL	04/17/2016 & 04/18/2016	TB

<b>SEARCH NOTES</b>		
Search Notes	Date	Examiner

	/TESFALDET BOCURE/ Primary Examiner.Art Unit 2634
--	--



### SEARCH NOTES

Search Notes	Date	Examiner
WEST and Inventor's Name Searched	01/22/2016	TB
See Realted parent application 14/733,565 for further presecution History	01/22/2016	TB
WEST Search Updated	01/23/2016	TB
WEST Search Updated	04/17/2016	TB
WEST Search Updated	04/18/2016	TB

### INTERFERENCE SEARCH

US Class/ CPC Symbol	US Subclass / CPC Group	Date	Examiner
375	240, 240.1	04/18/2016	TB
CPC	(H03M7/30 H03M7/3084 H03M7/6094 H04N19/164 H04N19/176 H04N19/103).CPC.	04/18/2016	TB

/TESFALDET BOCURE/  
Primary Examiner.Art Unit 2634



Substitute for form 1449/PTO		<b>Complete if Known</b>	
<b>FIFTH SUPPLEMENTAL INFORMATION DISCLOSURE STATEMENT BY APPLICANT</b> <i>(Use as many sheets as necessary)</i>		Application Number	14/876,276
		Filing Date	October 6, 2015
		First Named Inventor	James J. FALLON
		Art Unit	2634
		Examiner Name	BOCURE, TESFALDET
		Attorney Docket Number	3421.005000C
Sheet	1	of	3

NON PATENT LITERATURE DOCUMENTS			
Examiner Initials*	Cite No. <sup>1</sup>	Include name of the author (in CAPITAL LETTERS), title of the article (when appropriate), title of the item (book, magazine, journal, serial, symposium, catalog, etc.), date, page(s), volume-issue number(s), publisher, city and/or country where published	T <sup>2</sup>
	NPL1	Dell Inc.'s Answer, Defenses, and Counterclaims to Plaintiff's Second Amended Complaint, filed in Realtime Data, LLC d/b/a IXO v. Actian Corporation, et al., Case No. 6:15-cv-00463-RWS-JDL (E.D. Tex.), filed February 19, 2016; 18 pages.	
	NPL2	Riverbed Technology's Answer, Defenses, and Counterclaims, filed in Realtime Data, LLC d/b/a IXO v. Actian Corporation, et al., Case No. 6:15-cv-00463-RWS-JDL (E.D. Tex.), filed February 19, 2016; 26 pages.	
	NPL3	Complaint for Patent Infringement Against Dell Inc., EMC Corporation, iland Internet Solutions Corporation, and Veeam Software Corporation, filed in Realtime Data d/b/a IXO v. Dell Inc., et al., Case No. 6:16-cv-00089 (E.D. Texas), filed February 26, 2016; 67 pages.	
	NPL4	Complaint for Patent Infringement Against Hewlett Packard Enterprise Co., HP Enterprise Services, LLC, and Silver Peak Systems, Inc., filed in Realtime Data d/b/a IXO v. Hewlett Packard Enterprise, Co., et al., Case No. 6:16-cv-00086 (E.D. Texas), filed February 26, 2016; 49 pages.	
	NPL5	Complaint for Patent Infringement Against CenturyLink, Inc. and Veritas Technologies LLC, filed in Realtime Data d/b/a IXO v. CenturyLink, Inc., et al., Case No. 6:16-cv-00087 (E.D. Texas), filed February 26, 2016; 46 pages.	
	NPL6	Complaint for Patent Infringement Against Oracle America, Inc., filed in Realtime Data d/b/a IXO v. Oracle America, Inc., Case No. 6:16-cv-00088 (E.D. Texas), filed February 26, 2016; 40 pages.	
	NPL7	Realtime Data LLC d/b/a IXO's Answer to Echostar Corporation's and Hughes Network Systems, LLC's Counterclaims, filed Realtime Data LLC d/b/a IXO v. Actian Corporation, et al., Case No. 6:15-cv-000463-RWS-JDL (E.D. Texas), filed February 25, 2016; 8 pages.	
	NPL8	Realtime Data LLC d/b/a IXO's Answer to SAP America Inc.'s and Sybase, Inc.'s Counterclaims, filed Realtime Data LLC d/b/a IXO v. Actian Corporation, et al., Case No. 6:15-cv-000463-RWS-JDL (E.D. Texas), filed February 25, 2016; 5 pages.	
	NPL9	Realtime Data LLC d/b/a IXO's Answer to Dell, Inc.'s Counterclaims, filed Realtime Data LLC d/b/a IXO v. Actian Corporation, et al., Case No. 6:15-cv-000463-RWS-JDL (E.D. Texas), filed February 25, 2016; 5 pages.	
	NPL10	Copy of Non-Final Office Action for U.S. Appl. No.14/853,581, mailed March 15, 2016; 5 pages.	

Examiner Signature	/Tsfaldet Bocure/	Date Considered	04/18/2016
--------------------	-------------------	-----------------	------------

\*EXAMINER: Initial if reference considered, whether or not citation is in conformance with MPEP 609. Draw line through citation if not in conformance and not considered. Include copy of this form with next communication to applicant.

<sup>1</sup> Applicant's unique citation designation number (optional). <sup>2</sup> Applicant is to place a check mark here if English language Translation is attached.

**ALL REFERENCES CONSIDERED EXCEPT WHERE LINED THROUGH. /T.B./**

Substitute for form 1449/PTO		<b>Complete if Known</b>	
<b>FIFTH SUPPLEMENTAL INFORMATION DISCLOSURE STATEMENT BY APPLICANT</b> <i>(Use as many sheets as necessary)</i>		Application Number	14/876,276
		Filing Date	October 6, 2015
		First Named Inventor	James J. FALLON
		Art Unit	2634
		Examiner Name	BOCURE, TESFALDET
		Attorney Docket Number	3421.005000C
Sheet	2	of	3

NON PATENT LITERATURE DOCUMENTS			
Examiner Initials*	Cite No. <sup>1</sup>	Include name of the author (in CAPITAL LETTERS), title of the article (when appropriate), title of the item (book, magazine, journal, serial, symposium, catalog, etc.), date, page(s), volume number, publisher, city and/or country where published	T <sup>2</sup>
	NPL11	Copy of Notice of Allowance for U.S. Patent Appl. No. 14/733,565, mailed March 25, 2016; 8 pages.	
	NPL12	Petition for Inter Partes Review of Claims 1-4, 8, 14-17, 21 and 28 of U.S. Patent No. 6,597,812, filed in SAP America Inc., et al. v. Realtime Data, LLC d/b/a IXO, Case No. IPR2016-00783 (P.T.A.B.), filed April 1, 2016; 67 pages.	
	NPL13	Declaration of Scott Bennett, Ph.D., filed in SAP America Inc., et al. v. Realtime Data LLC d/b/a IXO, Case No. IPR2016-00783 (P.T.A.B.), filed April 1, 2016; 45 pages.	
	NPL14	Declaration of Charles D. Creusere in Support of Petition for Inter Partes Review of Claims 1-4, 8, 14-17, 21 and 28 of U.S. Patent No. 6,597,812, filed in SAP America Inc., et al. v. Realtime Data LLC d/b/a IXO, Case No. IPR2016-00783 (P.T.A.B.), filed April 1, 2016; 82 pages.	
	NPL15	NELSON, M., The Data Compression Book, 1st Edition, San Mateo, CA: M&T Books, 1992; 534 pages.	
	NPL16	RANDELL, B., "Hardware/Software Tradeoffs: A General Design Principle?", Computing Laboratory, The University of Newcastle Upon Tyne, January 25, 1985; 2 pages.	
	NPL17	Definition of "consecutive", Random House Webster's College Dictionary, 2nd Edition, New York: Random House, 1998; p. 281.	
	NPL18	ROBINSON, et al., "Results of a Prototype Television Bandwidth Compression Scheme," Proceedings of the IEEE, Vol. 55, No. 3, March 1967; pp. 356-364.	
	NPL19	Court Docket History for Realtime Data LLC d/b/a IXO v. Hewlett Packard Enterprise Co., et al., No. 6:16-cv-00086 (E.D. Texas), downloaded March 1, 2016, 2 pages.	
	NPL20	Court Docket History for Realtime Data LLC d/b/a IXO v. Oracle America, Inc., No. 6:16-cv-00088 (E.D. Texas), downloaded March 1, 2016; 2 pages.	

Examiner Signature	/Tesfaldet Bocure/	Date Considered	04/18/2016
-----------------------	--------------------	--------------------	------------

\*EXAMINER: Initial if reference considered, whether or not citation is in conformance with MPEP 609. Draw line through citation if not in conformance and not considered. Include copy of this form with next communication to applicant.

<sup>1</sup> Applicant's unique citation designation number (optional). <sup>2</sup> Applicant is to place a check mark here if English language Translation is attached.

**ALL REFERENCES CONSIDERED EXCEPT WHERE LINED THROUGH. /T.B./**



## WEST Search History for Application 14876276

Creation Date: 2016041809:16

### Prior Art Searches

Query	DB	Hits	Op.	Plur.	Thes.	Date
((Fallen adj James).in. or (McErlain adj Stephen).in.)	PGPB, USPT, USOC, EPAB, JPAB, DWPI, TDBD	n/a	OR	YES		04-18-2016
((Fallen).in. or (McErlain).in.)	PGPB, USPT, USOC, EPAB, JPAB, DWPI, TDBD	n/a	OR	YES		04-18-2016
(select\$4 or choos\$4) near4 ((multiple or plural\$4 or two or three or four or five) near5 encoder\$) same ((assymetric\$ or (lempel adj2 ziv)) near4 (compressing or compression))	PGPB, USPT, USOC, EPAB, JPAB, DWPI, TDBD	n/a	OR	YES		04-18-2016
(select\$4 or choos\$4) near4 ((multiple or plural\$4 or two or three or four or five) near5 encoder\$) and ((assymetric\$ or (lempel adj2 ziv)) near4 (compressing or compression))	PGPB, USPT, USOC, EPAB, JPAB, DWPI, TDBD	n/a	OR	YES		04-18-2016
((select\$4 or choos\$4) near4 ((multiple or plural\$4 or two or three or four or five) near5 encoder\$) and ((assymetric\$ or (lempel adj2 ziv)) near4 (compressing or compression)) ) and @ad<=20010213	PGPB, USPT, USOC, EPAB, JPAB, DWPI, TDBD	n/a	OR	YES		04-18-2016
((select\$4 or choos\$4) near4 ((multiple or plural\$4 or two or three or four or five) near5 encoder\$) and ((assymetric\$ or (lempel adj2 ziv)) near4	PGPB, USPT, USOC,	n/a	OR	YES		04-18-2016

<b>((compressing or compression)) ) and ( (((Fallen adj James).in. or (McErlain adj Stephen).in.) ) or (((Fallen).in. or (McErlain).in.) ) )</b>	EPAB, JPAB, DWPI, TDBD					
<b>((select\$4 or choos\$4) near4 ((multiple or plural\$4 or two or three or four or five) near5 encoder\$) and ((assymetric\$ or (lempel adj2 ziv)) near4 (compressing or compression)) ) and ( (((Fallen adj James).in. or (McErlain adj Stephen).in.) ) )</b>	PGPB, USPT, USOC, EPAB, JPAB, DWPI, TDBD	n/a	OR	YES		04-18-2016
<b>(selecting or select or choose or choosing) near4 ((compress or compression or compressing) near4 (algorithm or algorithms or mode or modes)) same ((assymetric\$4 or (lempel adj2 ziv)) near4 (compressing or compression))</b>	PGPB, USPT, USOC, EPAB, JPAB, DWPI, TDBD	n/a	OR	YES		04-18-2016
<b>((compress or compression or compressing) near4 (algorithm or algorithms or mode or modes)) same (parameter or parameters or attribute or attributes) same (assymetric \$4near4 (compressing or compression))</b>	PGPB, USPT, USOC, EPAB, JPAB, DWPI, TDBD	n/a	OR	YES		04-18-2016
<b>((compress or compression or compressing) near4 (algorithm or algorithms or mode or modes)) same (parameter or parameters or attribute or attributes) same (assymetric\$4 near4 (compressing or compression))</b>	PGPB, USPT, USOC, EPAB, JPAB, DWPI, TDBD	n/a	OR	YES		04-18-2016
<b>((compress or compression or compressing) near4 (algorithm or algorithms or mode or modes)) same (parameter or parameters or attribute or attributes) same ((fast near4 slow) near4 (compressing or compression))</b>	PGPB, USPT, USOC, EPAB, JPAB, DWPI, TDBD	n/a	OR	YES		04-18-2016
<b>((multiple or plural\$4 or two or three or four or five) near5 encoder\$) same ((assymetric\$ or (lempel adj2 ziv)) near4 (compressing or compression))</b>	PGPB, USPT, USOC, EPAB, JPAB, DWPI, TDBD	n/a	OR	YES		04-18-2016

<p>((selecting or select or choose or choosing) near4 ((compress or compression or compressing) near4 (algorithm or algorithms or mode or modes)) same ((assymmetric\$4 or (lempel adj2 ziv)) near4 (compressing or compression)) ) and (((H03M7/30)))   (((H03M7/3084)))   (((H03M7/6094)))   (((G06F15/7867)))   (((G06T1/60)))   (((H04N19/136))).CPC. )</p>	PGPB, USPT, USOC, EPAB, JPAB, DWPI, TDBD	n/a	OR	YES		04-18-2016
<p>(((multiple or plural\$4 or two or three or four or five) near5 encoder\$) same ((assymmetric\$ or (lempel adj2 ziv)) near4 (compressing or compression)) ) and (((H03M7/30)))   (((H03M7/3059)))   (((H03M7/3093)))   (((H04L69/04)))   (((H04N19/152)))   (((H04N9/8042))).CPC. )</p>	PGPB, USPT, USOC, EPAB, JPAB, DWPI, TDBD	n/a	OR	YES		04-18-2016
<p>("20010019630"   "20010031092"   "20010032128"   "20010047473"   "20010052038"   "20020037035"   "20020069354"   "20020078241"   "20020080871"   "20020097172"   "20020101367"   "20020104891"   "20020126755"   "20020169950"   "20020191692"   "20030030575"   "20030034905"   "20030058873"   "20030084238").PN.</p>	PGPB, USPT, USOC, EPAB, JPAB, DWPI, TDBD	n/a	OR	YES		04-18-2016
<p>(((375/\$8)).ccls. or ((370/\$8)).ccls. or ((348/\$8)).ccls. or ((341/\$8)).ccls. or ((711/\$8)).ccls. or ((701/\$8)).ccls. or ((381/\$8)).ccls. or ((375/382)).ccls. )</p>	PGPB, USPT, USOC, EPAB, JPAB, DWPI, TDBD	n/a	OR	YES		04-18-2016
<p>(((375/\$8)).ccls. or ((370/\$8)).ccls. or ((348/\$8)).ccls. or ((341/\$8)).ccls. or ((711/\$8)).ccls. or ((701/\$8)).ccls. or ((381/\$8)).ccls. or ((375/382)).ccls. ) and ( ((select\$4 or choos\$4) near4 ((multiple or plural\$4 or two or three or four or five) near5 encoder\$) and ((assymmetric\$ or (lempel adj2 ziv)) near4 (compressing or compression)) ) or ((selecting or select or choose or choosing) near4 ((compress or compression or compressing) near4 (algorithm or algorithms or mode or modes)) same ((assymmetric\$4 or (lempel adj2 ziv)) near4 (compressing or compression)) ) or (((multiple or plural\$4 or two or three or four or five) near5 encoder\$) same ((assymmetric\$ or (lempel adj2 ziv)) near4 (compressing or compression)) ) )</p>	PGPB, USPT, USOC, EPAB, JPAB, DWPI, TDBD	n/a	OR	YES		04-18-2016
<p>(((375/240)).ccls. or ((375/240.01)).ccls. or ((375/240.02)).ccls. or ((341/50)).ccls. or ((341/51)).ccls. or ((341/126)).ccls. ) and ( ((select\$4</p>	PGPB, USPT, USOC,	n/a	OR	YES		04-18-2016



<p>or choos\$4) near4 ((multiple or plural\$4 or two or three or four or five) near5 encoder\$) and ((assymmetric\$ or (lempel adj2 ziv)) near4 (compressing or compression)) ) or ((selecting or select or choose or choosing) near4 ((compress or compression or compressing) near4 (algorithm or algorithms or mode or modes)) same ((assymmetric\$4 or (lempel adj2 ziv)) near4 (compressing or compression)) ) or (((multiple or plural\$4 or two or three or four or five) near5 encoder\$) same ((assymmetric\$ or (lempel adj2 ziv)) near4 (compressing or compression)) ) )</p>	<p>EPAB, JPAB, DWPI, TDBD</p>					
<p>((multiple or plural\$4 or two or three or four or five) near5 encoder\$) same ((assymmetric\$3 or (lempel adj2 ziv) and (arithmetic)) near4 (compressing or compression))</p>	<p>PGPB, USPT, USOC, EPAB, JPAB, DWPI, TDBD</p>	<p>n/a</p>	<p>OR</p>	<p>YES</p>		<p>04-18-2016</p>
<p>( ((select\$4 or choos\$4) near4 ((multiple or plural\$4 or two or three or four or five) near5 encoder\$) and ((assymmetric\$ or (lempel adj2 ziv)) near4 (compressing or compression)) ) or ((selecting or select or choose or choosing) near4 ((compress or compression or compressing) near4 (algorithm or algorithms or mode or modes)) same ((assymmetric\$4 or (lempel adj2 ziv)) near4 (compressing or compression)) ) or (((multiple or plural\$4 or two or three or four or five) near5 encoder\$) same ((assymmetric\$ or (lempel adj2 ziv)) near4 (compressing or compression)) ) or (((multiple or plural\$4 or two or three or four or five) near5 encoder\$) same ((assymmetric\$3 or (lempel adj2 ziv) and (arithmetic)) near4 (compressing or compression)) ) )</p>	<p>PGPB, USPT, USOC, EPAB, JPAB, DWPI, TDBD</p>	<p>n/a</p>	<p>OR</p>	<p>YES</p>		<p>04-18-2016</p>
<p>(((select\$4 or choos\$4) near4 ((multiple or plural\$4 or two or three or four or five) near5 encoder\$) and ((assymmetric\$ or (lempel adj2 ziv)) near4 (compressing or compression)) or (selecting or select or choose or choosing) near4 ((compress or compression or compressing) near4 (algorithm or algorithms or mode or modes)) same ((assymmetric\$4 or (lempel adj2 ziv)) near4 (compressing or compression)) or ((multiple or plural\$4 or two or three or four or five) near5 encoder\$) same ((assymmetric\$ or (lempel adj2 ziv)) near4 (compressing or compression)) or ((multiple or plural\$4 or two or three or four or five) near5 encoder\$) same ((assymmetric\$3 or (lempel adj2 ziv) and (arithmetic)) near4 (compressing or compression)) ) )</p>	<p>PGPB, USPT, USOC, EPAB, JPAB, DWPI, TDBD</p>	<p>n/a</p>	<p>OR</p>	<p>YES</p>		<p>04-18-2016</p>

<p>and (arithmetic)) near4 (compressing or compression)) ) ) and (((375/240)).ccls. or ((375/240.01)).ccls. or ((375/240.02)).ccls. or ((341/50)).ccls. or ((341/51)).ccls. or ((341/126)).ccls. ) and ((select\$4 or choos\$4) near4 ((multiple or plural\$4 or two or three or four or five) near5 encoder\$) and ((assymetric\$ or (lempel adj2 ziv)) near4 (compressing or compression)) or (selecting or select or choose or choosing) near4 ((compress or compression or compressing) near4 (algorithm or algorithms or mode or modes)) same ((assymetric\$4 or (lempel adj2 ziv)) near4 (compressing or compression)) or ((multiple or plural\$4 or two or three or four or five) near5 encoder\$) same ((assymetric\$ or (lempel adj2 ziv)) near4 (compressing or compression)) ) )</p>						
<p>((select\$4 or choos\$4) near4 ((multiple or plural\$4 or two or three or four or five) near5 encoder\$) and ((assymetric\$ or (lempel adj2 ziv)) near4 (compressing or compression)) or (selecting or select or choose or choosing) near4 ((compress or compression or compressing) near4 (algorithm or algorithms or mode or modes)) same ((assymetric\$4 or (lempel adj2 ziv)) near4 (compressing or compression)) or ((multiple or plural\$4 or two or three or four or five) near5 encoder\$) same ((assymetric\$ or (lempel adj2 ziv)) near4 (compressing or compression)) or ((multiple or plural\$4 or two or three or four or five) near5 encoder\$) same ((assymetric\$3 or (lempel adj2 ziv)) and (arithmetic)) near4 (compressing or compression)) ) ) and (((375/\$8)).ccls. or ((370/\$8)).ccls. or ((348/\$8)).ccls. or ((341/\$8)).ccls. or ((711/\$8)).ccls. or ((701/\$8)).ccls. or ((381/\$8)).ccls. or ((375/382)).ccls. ) )</p>	<p>PGPB, USPT, USOC, EPAB, JPAB, DWPI, TDBD</p>	<p>n/a</p>	<p>OR</p>	<p>YES</p>		<p>04-18-2016</p>
<p>((select\$4 or choos\$4) near4 ((multiple or plural\$4 or two or three or four or five) near5 encoder\$) and ((assymetric\$ or (lempel adj2 ziv)) near4 (compressing or compression)) or (selecting or select or choose or choosing) near4 ((compress or compression or compressing) near4 (algorithm or algorithms or mode or modes)) same ((assymetric\$4 or (lempel adj2 ziv)) near4 (compressing or compression)) or ((multiple or plural\$4 or two or three or four or five) near5 encoder\$) same ((assymetric\$ or (lempel adj2 ziv)) near4 (compressing or compression)) or ((multiple or plural\$4 or two or three or four or five) near5 encoder\$) same ((assymetric\$3 or (lempel adj2 ziv))</p>	<p>PGPB, USPT, USOC, EPAB, JPAB, DWPI, TDBD</p>	<p>n/a</p>	<p>OR</p>	<p>YES</p>		<p>04-18-2016</p>

and (arithmetic) near4 (compressing or compression) ) ) and (((H03M7/30)   (H03M7/3059)   (H03M7/3084)   (H03M7/6094)   (H03M7/3088)   (H03M7/6023)   (H03M7/6064)   (H04N19/152)   (G11B20/00007)).CPC. )						
("20150334390"   "3394352"   "3490690"   "4021782"   "4032893"   "4054951"   "4127518"   "4302775"   "4325085"   "4360840"   "4386416"   "4394774"   "4464650"   "4494108"   "4499499"   "4574351"   "4626829"   "4646061"   "4682150"   "4701745").PN.	PGPB, USPT, USOC, EPAB, JPAB, DWPI, TDBD	n/a	OR	YES		04-18-2016
((("20150334390"   "3394352"   "3490690"   "4021782"   "4032893"   "4054951"   "4127518"   "4302775"   "4325085"   "4360840"   "4386416"   "4394774"   "4464650"   "4494108"   "4499499"   "4574351"   "4626829"   "4646061"   "4682150"   "4701745").PN. ) and (((select\$4 or choos\$4) near4 ((multiple or plural\$4 or two or three or four or five) near5 encoder\$) and ((assymetric\$ or (lempel adj2 ziv)) near4 (compressing or compression)) or (selecting or select or choose or choosing) near4 ((compress or compression or compressing) near4 (algorithm or algorithms or mode or modes)) same ((assymetric\$4 or (lempel adj2 ziv)) near4 (compressing or compression)) or ((multiple or plural\$4 or two or three or four or five) near5 encoder\$) same ((assymetric\$ or (lempel adj2 ziv)) near4 (compressing or compression)) or ((multiple or plural\$4 or two or three or four or five) near5 encoder\$) same ((assymetric\$3 or (lempel adj2 ziv) and (arithmetic) near4 (compressing or compression) ) )	PGPB, USPT, USOC, EPAB, JPAB, DWPI, TDBD	1	OR	YES		04-18-2016
("4558302"   "4568983"   "5046119"   "5227878"   "5333212"   "5379351"   "5379356"   "5402146"   "5408542"   "5684478"   "5870036"   "6023233"   "6092071"   "6169499"   "6215983"   "6370631"   "6404919"   "20160029018"   "5479210"   "5590317"   "5710562"   "6233017"   "6744926"   "7496586"   "5479210"   "5590317"   "5710562"   "6233017"   "6744926"   "7496586"   "3560639"   "5467134"   "5623483"   "5664226").PN.	PGPB, USPT, USOC, EPAB, JPAB, DWPI, TDBD	74	OR	YES		04-18-2016
(((select\$4 or choos\$4) near4 ((multiple or plural\$4 or two or three or four or five) near5 encoder\$) and ((assymetric\$ or (lempel adj2 ziv)) near4 (compressing or compression)) or (selecting or select or choose or choosing) near4 ((compress or compression or compressing) near4 (algorithm or	PGPB, USPT, USOC, EPAB, JPAB, DWPI,	59	OR	YES		04-18-2016

<p>algorithms or mode or modes)) same        ((asymmetric\$4 or (lempel adj2 ziv)) near4        (compressing or compression)) or ((multiple or        plural\$4 or two or three or four or five) near5        encoder\$) same ((asymmetric\$ or (lempel adj2 ziv))        near4 (compressing or compression)) or ((multiple        or plural\$4 or two or three or four or five) near5        encoder\$) same ((asymmetric\$3 or (lempel adj2 ziv)        and (arithmetic)) near4 (compressing or        compression)) ) ) and (H03M7/30   H03M7/3084          H03M7/6094   H04N19/164   HO4N19/176          H04N19/103).CPC.</p>	TDBD					
---	------	--	--	--	--	--



Substitute for form 1449/PTO		<i>Complete if Known</i>	
<b>THIRD SUPPLEMENTAL INFORMATION DISCLOSURE STATEMENT BY APPLICANT</b> <i>(Use as many sheets as necessary)</i>		Application Number	14/876,276
		Filing Date	October 6, 2015
		First Named Inventor	James J. FALLON
		Art Unit	2634
		Examiner Name	BOCURE, TESFALDET
		Attorney Docket Number	3421.005000C
Sheet	1	of	4

NON PATENT LITERATURE DOCUMENTS			
Examiner Initials*	Cite No. <sup>1</sup>	Include name of the author (in CAPITAL LETTERS), title of the article (when appropriate), title of the item (book, magazine, journal, serial, symposium, catalog, etc.), date, page(s), volume-issue number(s), publisher, city and/or country where published	T <sup>2</sup>
	NPL1	Order Adopting Report and Recommendation of United States Magistrate Judge, filed in Realtime Data, LLC d/b/a IXO v. Actian Corporation, et al., Case No. 6:15-cv-00463-RWS-JDL (E.D. Texas), filed January 21, 2016; 4 pages.	
	NPL2	Defendants' Preliminary Invalidation Contentions, submitted in Realtime Data, LLC d/b/a IXO v. Actian Corporation, et al., Case No. 6:15-cv-0063-RWS-JDL (E.D. Texas), served December 4, 2015; 138 pages.	
	NPL3	Non-Confidential Exhibits A1-A7 and A9-A10 to Defendants' Preliminary Invalidation Contentions, submitted in Realtime Data, LLC d/b/a IXO v. Actian Corporation, et al., Case No. 6:15-cv-0063-RWS-JDL (E.D. Texas), served December 4, 2015; 743 pages.	
	NPL4	Non-confidential Exhibits B1-B17 and B19 to Defendants' Preliminary Invalidation Contentions, submitted in Realtime Data, LLC d/b/a IXO v. Actian Corporation, et al., Case No. 6:15-cv-0063-RWS-JDL (E.D. Texas), served December 4, 2015; 506 pages.	
	NPL5	Non-Confidential Exhibits C1-C36 to Defendants' Preliminary Invalidation Contentions, submitted in Realtime Data, LLC d/b/a IXO v. Actian Corporation, et al., Case No. 6:15-cv-0063-RWS-JDL (E.D. Texas), served December 4, 2015; 1,445 pages.	
	NPL6	Non-Confidential Exhibits D1-D14 and D16 to Defendants' Preliminary Invalidation Contentions, submitted in Realtime Data, LLC d/b/a IXO v. Actian Corporation, et al., Case No. 6:15-cv-0063-RWS-JDL (E.D. Texas), served December 4, 2015; 1,052 pages.	
	NPL7	Non-Confidential Exhibits E1-E36 to Defendants' Preliminary Invalidation Contentions, submitted in Realtime Data, LLC d/b/a IXO v. Actian Corporation, et al., Case No. 6:15-cv-0063-RWS-JDL (E.D. Texas), served December 4, 2015; 1,205 pages.	
	NPL8	KATZ, ET AL., "The Bay Area Research Wireless Access Network (BARWAN)," Proceedings of COMPCON '96, 1996; pp. 15-20.	
	NPL9	U.S. Provisional Patent Application No. 60/100,671, "Hybrid Compression Method with Compression Ratio Control," filed September 16, 1998; 50 pages.	
	NPL10	WELCH, T., "A Technique for High-Performance Data Compression," Computer, Vol. 18, Issue 6, 1984; pp. 8-19.	

Examiner Signature	/Teskaldet Bocure/	Date Considered	04/18/2016
-----------------------	--------------------	--------------------	------------

\*EXAMINER: Initial if reference considered, whether or not citation is in conformance with MPEP 609. Draw line through citation if not in conformance and not considered. Include copy of this form with next communication to applicant.

<sup>1</sup> Applicant's unique citation designation number (optional). <sup>2</sup> Applicant is to place a check mark here if English language Translation is attached.

ALL REFERENCES CONSIDERED EXCEPT WHERE LINED THROUGH. /T.B./

Substitute for form 1449/PTO		<b>Complete if Known</b>	
<b>THIRD SUPPLEMENTAL INFORMATION DISCLOSURE STATEMENT BY APPLICANT</b> <i>(Use as many sheets as necessary)</i>		Application Number	14/876,276
		Filing Date	October 6, 2015
		First Named Inventor	James J. FALLON
		Art Unit	2634
		Examiner Name	BOCURE, TESFALDET
		Attorney Docket Number	3421.005000C
Sheet	2	of	4

NON PATENT LITERATURE DOCUMENTS			
Examiner Initials*	Cite No. <sup>1</sup>	Include name of the author (in CAPITAL LETTERS), title of the article (when appropriate), title of the item (book, magazine, journal, serial, symposium, catalog, etc.), date, page(s), volume number, publisher, city and/or country where published	T <sup>2</sup>
	NPL11	Internet Archive version of the web page <a href="http://www.imatix.com/index.htm">www.imatix.com/index.htm</a> , dated May 20, 1998, available at <a href="http://web.archive.org/web/19980520033922/http://imatix.com/index.htm">http://web.archive.org/web/19980520033922/http://imatix.com/index.htm</a> ; 1 page.	
	NPL12	Internet Archive version of the web page <a href="http://www.imatix.com/index.htm">www.imatix.com/index.htm</a> , dated January 10, 1998, available at <a href="http://web.archive.org/web/19980110141513/http://imatix.com/index.htm">http://web.archive.org/web/19980110141513/http://imatix.com/index.htm</a> ; 1 page.	
	NPL13	Internet Archive version of the web page <a href="http://www.imatix.com/">www.imatix.com/</a> , dated January 9, 1998, available at <a href="https://web.archive.org/web/19980109064903/http://imatix.com/">https://web.archive.org/web/19980109064903/http://imatix.com/</a> ; 1 page.	
	NPL14	Internet Archive version of the web page <a href="http://www.imatix.com/">www.imatix.com/</a> , dated October 14, 1997, available at <a href="https://web.archive.org/web/19971014195839/http://www.imatix.com/">https://web.archive.org/web/19971014195839/http://www.imatix.com/</a> ; 1 page.	
	NPL15	Internet Archive version of the web page <a href="http://www.imatix.com/">www.imatix.com/</a> , dated June 29, 1997, available at <a href="https://web.archive.org/web/19970629063852/http://www.imatix.com/">https://web.archive.org/web/19970629063852/http://www.imatix.com/</a> ; 2 pages.	
	NPL16	Internet Archive version of the web page <a href="http://www.imatix.com/">www.imatix.com/</a> , dated April 16, 1997, available at <a href="https://web.archive.org/web/19970416061218/http://imatix.com/">https://web.archive.org/web/19970416061218/http://imatix.com/</a> ; 2 pages.	
	NPL17	Internet Archive version of the web page <a href="http://www.imatix.com/">www.imatix.com/</a> , dated December 21, 1996, available at <a href="https://web.archive.org/web/19961221064553/http://imatix.com/">https://web.archive.org/web/19961221064553/http://imatix.com/</a> ; 2 pages.	
	NPL18	Internet Archive version of the web page <a href="http://www.imatix.com/">www.imatix.com/</a> , dated November 6, 1996, available at <a href="https://web.archive.org/web/19961106161211/http://imatix.com/">https://web.archive.org/web/19961106161211/http://imatix.com/</a> ; 2 pages.	
	NPL19	"Liberetto, The iMatix Newsletter," vol. III, issue 9, September 1998, available at <a href="http://legacy.imatix.com/html/libero/doc/news9809.txt">http://legacy.imatix.com/html/libero/doc/news9809.txt</a> ; 9 pages.	
	NPL20	"Liberetto, The iMatix Newsletter," vol. III, issue 4, April 1998, available at <a href="http://legacy.imatix.com/html/libero/doc/news9804.txt">http://legacy.imatix.com/html/libero/doc/news9804.txt</a> ; 8 pages.	

Examiner Signature	/Teskaldet Bocure/	Date Considered	04/18/2016
-----------------------	--------------------	--------------------	------------

\*EXAMINER: Initial if reference considered, whether or not citation is in conformance with MPEP 609. Draw line through citation if not in conformance and not considered. Include copy of this form with next communication to applicant.

<sup>1</sup> Applicant's unique citation designation number (optional). <sup>2</sup> Applicant is to place a check mark here if English language Translation is attached.

ALL REFERENCES CONSIDERED EXCEPT WHERE LINED THROUGH. /T.B./

Substitute for form 1449/PTO		<b>Complete if Known</b>	
<b>THIRD SUPPLEMENTAL INFORMATION DISCLOSURE STATEMENT BY APPLICANT</b> <i>(Use as many sheets as necessary)</i>		Application Number	14/876,276
		Filing Date	October 6, 2015
		First Named Inventor	James J. FALLON
		Art Unit	2634
		Examiner Name	BOCURE, TESFALDET
Sheet	3	of	4
		Attorney Docket Number	3421.005000C

NON PATENT LITERATURE DOCUMENTS			
Examiner Initials*	Cite No. <sup>1</sup>	Include name of the author (in CAPITAL LETTERS), title of the article (when appropriate), title of the item (book, magazine, journal, serial, symposium, catalog, etc.), date, page(s), volume number, publisher, city and/or country where published	T <sup>2</sup>
	NPL21	"Liberetto, The iMatix Newsletter," vol. III, issue 1, January 1998, available at <a href="http://legacy.imatix.com/html/libero/doc/news9801.txt">http://legacy.imatix.com/html/libero/doc/news9801.txt</a> ; 7 pages.	
	NPL22	"Liberetto, The iMatix Newsletter," vol. II, issue 8, August 1997, available at <a href="http://legacy.imatix.com/html/libero/doc/news9708.txt">http://legacy.imatix.com/html/libero/doc/news9708.txt</a> ; 8 pages.	
	NPL23	"Liberetto, The iMatix Newsletter," vol. II, issue 6, June 1997, available at <a href="http://legacy.imatix.com/html/libero/doc/news9706.txt">http://legacy.imatix.com/html/libero/doc/news9706.txt</a> ; 6 pages.	
	NPL24	"Liberetto, The iMatix Newsletter," vol. II, issue 2, February 1997, available at <a href="http://legacy.imatix.com/html/libero/doc/news9702.txt">http://legacy.imatix.com/html/libero/doc/news9702.txt</a> ; 9 pages.	
	NPL25	Internet Archive version of the web page <a href="http://www.seas.upenn.edu/~liefke/">www.seas.upenn.edu/~liefke/</a> , dated October 5, 1999, available at <a href="https://web.archive.org/web/19991005050552/http://www.seas.upenn.edu/~liefke/">https://web.archive.org/web/19991005050552/http://www.seas.upenn.edu/~liefke/</a> ; 2 pages.	
	NPL26	Internet Archive version of the web page <a href="http://www.seas.upenn.edu/~liefke/research.html">www.seas.upenn.edu/~liefke/research.html</a> , dated January 18, 2000, available at <a href="https://web.archive.org/web/20000118224540/http://www.seas.upenn.edu/~liefke/research.html">https://web.archive.org/web/20000118224540/http://www.seas.upenn.edu/~liefke/research.html</a> ; 2 pages.	
	NPL27	Internet Archive version of the web page <a href="http://www.seas.upenn.edu/~liefke/xmlzip.html">www.seas.upenn.edu/~liefke/xmlzip.html</a> , dated January 19, 2000, available at <a href="https://web.archive.org/web/20000119051403/http://www.seas.upenn.edu/~liefke/xmlzip.html">https://web.archive.org/web/20000119051403/http://www.seas.upenn.edu/~liefke/xmlzip.html</a> ; 4 pages.	
	NPL28	Internet Archive version of the web page <a href="http://www.research.att.com/~suciu/strudel/external/NodeExternal,internal.genoid_3.html">www.research.att.com/~suciu/strudel/external/NodeExternal,internal.genoid_3.html</a> , dated March 10, 2000, available at <a href="https://web.archive.org/web/20000310042016/http://www.research.att.com/~suciu/strudel/external/NodeExternal,internal.genoid_3.html">https://web.archive.org/web/20000310042016/http://www.research.att.com/~suciu/strudel/external/NodeExternal,internal.genoid_3.html</a> ; 12 pages.	
	NPL29	Internet Archive version of the web page <a href="http://www.research.att.com/sw/tools/xmill/">www.research.att.com/sw/tools/xmill/</a> , dated August 31, 2000, available at <a href="https://web.archive.org/web/20000831200854/http://www.research.att.com/sw/tools/xmill/">https://web.archive.org/web/20000831200854/http://www.research.att.com/sw/tools/xmill/</a> ; 2 pages.	
	NPL30	Internet Archive version of the web page <a href="http://www.research.att.com/sw/tools/xmill/download.html">www.research.att.com/sw/tools/xmill/download.html</a> , dated September 25, 2000, available at <a href="https://web.archive.org/web/20000925084557/http://www.research.att.com/sw/tools/xmill/download.html">https://web.archive.org/web/20000925084557/http://www.research.att.com/sw/tools/xmill/download.html</a> ; 1 page.	
Examiner Signature	/Tsfaldet Bocure/		Date Considered
			04/18/2016

\*EXAMINER: Initial if reference considered, whether or not citation is in conformance with MPEP 609. Draw line through citation if not in conformance and not considered. Include copy of this form with next communication to applicant.

<sup>1</sup> Applicant's unique citation designation number (optional). <sup>2</sup> Applicant is to place a check mark here if English language Translation is attached.

ALL REFERENCES CONSIDERED EXCEPT WHERE LINED THROUGH. /T.B./







Substitute for form 1449/PTO		<b>Complete if Known</b>	
<b>FOURTH SUPPLEMENTAL INFORMATION DISCLOSURE STATEMENT BY APPLICANT</b> <i>(Use as many sheets as necessary)</i>		Application Number	14/876,276
		Filing Date	October 6, 2015
		First Named Inventor	James J. FALLON
		Art Unit	2634
		Examiner Name	BOCURE, TESFALDET
		Attorney Docket Number	3421.005000C
Sheet	1	of	14

NON PATENT LITERATURE DOCUMENTS			
Examiner Initials*	Cite No. <sup>1</sup>	Include name of the author (in CAPITAL LETTERS), title of the article (when appropriate), title of the item (book, magazine, journal, serial, symposium, catalog, etc.), date, page(s), volume-issue number(s), publisher, city and/or country where published	T <sup>2</sup>
	NPL1	Second Amended Complaint for Patent Infringement Against Riverbed Technology, Inc. and Dell, Inc., filed in Realtime Data LLC d/b/a IXO v. Actian Corporation, et al., Case No. 6:15-cv-00463-RWS-JDL (E.D. Texas), filed February 2, 2016; 37 pages.	
	NPL2	Defendant Dropbox's Answer to Plaintiff Realtime Data LLC d/b/a IXO's Amended Complaint, filed in Realtime Data LLC d/b/a IXO v. Actian Corporation, et al., Case No. 6:15-cv-00463-RWS-JDL (E.D. Texas), filed February 4, 2016; 10 pages.	
	NPL3	Defendants Echostar Corporation's and Hughes Network Systems, LLC's Answer, Affirmative Defenses, and Counterclaims to Plaintiff Realtime Data LLC d/b/a IXO's Amended Complaint, filed in Realtime Data LLC d/b/a IXO v. Actian Corporation, et al., Case No. 6:15-cv-00463-RWS-JDL (E.D. Texas), filed February 4, 2016; 23 pages.	
	NPL4	Defendants SAP America Inc. and SyBase, Inc.'s Answer, Affirmative Defenses, and Counterclaims to Plaintiff's Second Amended Complaint, filed in Realtime Data LLC d/b/a IXO v. Actian Corporation, et al., Case No. 6:15-cv-00463-RWS-JDL (E.D. Texas), filed February 4, 2016; 35 pages.	
	NPL5	Dell Inc.'s Answer, Defenses, and Counterclaims to Plaintiff's Amended Complaint, filed in Realtime Data LLC d/b/a IXO v. Actian Corporation, et al., Case No. 6:15-cv-00463-RWS-JDL (E.D. Texas), filed February 4, 2016; 28 pages.	
	NPL6	Standard Function Library (SFL) Code, Version 1.4, written March 29, 1993, revised January 2, 1997; 190 pages.	
	NPL7	Standard Function Library Documentation, written June 4, 1997, revised November 17, 1997; 1,102 pages. (Submitted in 6 parts.)	
	NPL8	Defendants Oracle America, Inc., Hewlett-Packard Company, and HP Enterprise Services, LLC's Invalidity Contentions, submitted in Realtime Data, LLC d/b/a IXO v. Actian Corporation, et al., Case No. 6:15-cv-00463-RWS-JDL (E.D. Texas), served December 4, 2015; 62 pages.	
	NPL9	Non-Confidential Exhibits A3-A4 to Defendants Oracle America, Inc., Hewlett-Packard Company, and HP Enterprise Services, LLC's Invalidity Contentions, submitted in Realtime Data, LLC d/b/a IXO v. Actian Corporation, et al., Case No. 6:15-cv-00463-RWS-JDL (E.D. Texas), served December 4, 2015; 296 pages.	
	NPL10	Non-Confidential Exhibits B3-B4 to Defendants Oracle America, Inc., Hewlett-Packard Company, and HP Enterprise Services, LLC's Invalidity Contentions, submitted in Realtime Data, LLC d/b/a IXO v. Actian Corporation, et al., Case No. 6:15-cv-00463-RWS-JDL (E.D. Texas), served December 4, 2015; 1,179 pages.	
Examiner Signature	/Tesfaldet Bocure/		Date Considered 04/18/2016

\*EXAMINER: Initial if reference considered, whether or not citation is in conformance with MPEP 609. Draw line through citation if not in conformance and not considered. Include copy of this form with next communication to applicant.

<sup>1</sup> Applicant's unique citation designation number (optional). <sup>2</sup> Applicant is to place a check mark here if English language Translation is attached.

**ALL REFERENCES CONSIDERED EXCEPT WHERE LINED THROUGH. /T.B./**

Substitute for form 1449/PTO		<b>Complete if Known</b>	
<b>FOURTH SUPPLEMENTAL INFORMATION DISCLOSURE STATEMENT BY APPLICANT</b> <i>(Use as many sheets as necessary)</i>		Application Number	14/876,276
		Filing Date	October 6, 2015
		First Named Inventor	James J. FALLON
		Art Unit	2634
		Examiner Name	BOCURE, TESFALDET
		Attorney Docket Number	3421.005000C
Sheet	2	of	14

NON PATENT LITERATURE DOCUMENTS			
Examiner Initials*	Cite No. <sup>1</sup>	Include name of the author (in CAPITAL LETTERS), title of the article (when appropriate), title of the item (book, magazine, journal, serial, symposium, catalog, etc.), date, page(s), volume number, publisher, city and/or country where published	T <sup>2</sup>
	NPL11	Non-Confidential Exhibits C4-C7 and C9 to Defendants Oracle America, Inc., Hewlett-Packard Company, and HP Enterprise Services, LLC's Invalidation Contentions, submitted in Realtime Data, LLC d/b/a IXO v. Actian Corporation, et al., Case No. 6:15-cv-00463-RWS-JDL (E.D. Texas), served December 4, 2015; 3,029 pages.	
	NPL12	Non-Confidential Exhibits D4-D7 and D9 to Defendants Oracle America, Inc., Hewlett-Packard Company, and HP Enterprise Services, LLC's Invalidation Contentions, submitted in Realtime Data, LLC d/b/a IXO v. Actian Corporation, et al., Case No. 6:15-cv-00463-RWS-JDL (E.D. Texas), served December 4, 2015; 3,125 pages.	
	NPL13	Non-Confidential Exhibits E1-E4 to Defendants Oracle America, Inc., Hewlett-Packard Company, and HP Enterprise Services, LLC's Invalidation Contentions, submitted in Realtime Data, LLC d/b/a IXO v. Actian Corporation, et al., Case No. 6:15-cv-00463-RWS-JDL (E.D. Texas), served December 4, 2015; 1,657 pages.	
	NPL14	"Adaptive Lossless Data Compression Algorithm," ECMA Standard ECMA-222, June 1995; 20 pages.	
	NPL15	"ALDC1-40S Adaptive Lossless Data Compression," IBM Microelectronics Data Compression Technologies, May 1994; 2 pages.	
	NPL16	AMIR, ET AL., "An Application Level Video Gateway," ACM Multimedia, San Francisco, November 1995; 11 pages.	
	NPL17	ANDREWS, ET AL., "A Mean-Removed Variation of Weighted Universal Vector Quantization for Image Coding," IEEE Data Compression Conference, 1993; pp. 302-309.	
	NPL18	AX.25 Link Access Protocol for Amateur Packet Radio, Version 2.2, Tuscon Amateur Packet Radio Corporation, Revision: July 1998; 143 pages.	
	NPL19	BAKER, ET AL., "Lossless Data Compression for Short Duration 3D Frames in Positron Emission Tomography," IEEE Nuclear Science Symposium and Medical Imaging Conference, 1993; pp. 1831-1834.	
	NPL20	BASSIOUNI, ET AL., "A Scheme for Data Compression in Supercomputers," IEEE Supercomputing '88, 1988; pp. 272-278.	
Examiner Signature	/Teskaldet Bocure/		Date Considered 04/18/2016

\*EXAMINER: Initial if reference considered, whether or not citation is in conformance with MPEP 609. Draw line through citation if not in conformance and not considered. Include copy of this form with next communication to applicant.

<sup>1</sup> Applicant's unique citation designation number (optional). <sup>2</sup> Applicant is to place a check mark here if English language Translation is attached.

ALL REFERENCES CONSIDERED EXCEPT WHERE LINED THROUGH. /T.B./

Substitute for form 1449/PTO				<b>Complete if Known</b>	
<b>FOURTH SUPPLEMENTAL INFORMATION DISCLOSURE STATEMENT BY APPLICANT</b> <i>(Use as many sheets as necessary)</i>				Application Number	14/876,276
				Filing Date	October 6, 2015
				First Named Inventor	James J. FALLON
				Art Unit	2634
				Examiner Name	BOCURE, TESFALDET
Sheet	3	of	14	Attorney Docket Number	3421.005000C

NON PATENT LITERATURE DOCUMENTS			
Examiner Initials*	Cite No. <sup>1</sup>	Include name of the author (in CAPITAL LETTERS), title of the article (when appropriate), title of the item (book, magazine, journal, serial, symposium, catalog, etc.), date, page(s), volume number, publisher, city and/or country where published	T <sup>2</sup>
	NPL21	BRUCKMANN, ET AL., "Selective Medical Image Compression Using Wavelet Techniques," Journal of Computing and Information Technology, Vol. 6, No. 2 (1998); 23 pages.	
	NPL22	CHENG, ET AL., "A fast, highly reliable data compression chip and algorithm for storage systems," IBM Journal of Research and Development, Vol. 40, No. 6, November 1996; pp. 603-613.	
	NPL23	ZHANG, ET AL., "Content-based video retrieval and compression: a unified solution," IEEE Proceedings of the International Conference on Image Processing, October 1997; pp. 13-16.	
	NPL24	CRAFT, D., "A fast hardware data compression algorithm and some algorithmic extensions," IBM Journal of Research and Development, Vol. 42, No. 6, November 1998; pp. 733-745.	
	NPL25	SATTLER, M., Internet TV with CU-SeeMe, Indianapolis, IN: sams.net, 1995; 172 pages.	
	NPL26	DANSKIN, J., "Compressing The X Graphics Protocol," Dissertation, Princeton University Department of Computer Science, January 1995; 147 pages.	
	NPL27	FOX, ET AL., "Adapting to Network and Client Variability via On-Demand Dynamic Distillation," Proceedings of the Seventh International Conference on Architectural Support for Programming Languages and Operating Systems, 1996; pp. 160-170.	
	NPL28	FOX, ET AL., "Adapting to Network and Client Variability Using Infrastructural Proxies: Lessons and Perspectives," Abstract, IEEE Personal Communications, Vol. 5, No. 4, August 1998; 2 pages.	
	NPL29	BOTTOU, ET AL., "High Quality Document Image Compression with DjVu," Journal of Electronic Imaging, Vol. 7, No. 3, 1998; pp. 410-425.	
	NPL30	HOWARD, ET AL., "Parallel Lossless Image Compression Using Huffman and Arithmetic Coding," IEEE Data Compression Conference, March 1992; pp. 299-308.	

Examiner Signature	/Tesfaldet Bocure/	Date Considered	04/18/2016
-----------------------	--------------------	--------------------	------------

\*EXAMINER: Initial if reference considered, whether or not citation is in conformance with MPEP 609. Draw line through citation if not in conformance and not considered. Include copy of this form with next communication to applicant.

<sup>1</sup> Applicant's unique citation designation number (optional). <sup>2</sup> Applicant is to place a check mark here if English language Translation is attached.

ALL REFERENCES CONSIDERED EXCEPT WHERE LINED THROUGH. /T.B./

Substitute for form 1449/PTO		<b>Complete if Known</b>	
<b>FOURTH SUPPLEMENTAL INFORMATION DISCLOSURE STATEMENT BY APPLICANT</b> <i>(Use as many sheets as necessary)</i>		Application Number	14/876,276
		Filing Date	October 6, 2015
		First Named Inventor	James J. FALLON
		Art Unit	2634
		Examiner Name	BOCURE, TESFALDET
		Attorney Docket Number	3421.005000C
Sheet	4	of	14

NON PATENT LITERATURE DOCUMENTS			
Examiner Initials*	Cite No. <sup>1</sup>	Include name of the author (in CAPITAL LETTERS), title of the article (when appropriate), title of the item (book, magazine, journal, serial, symposium, catalog, etc.), date, page(s), volume number, publisher, city and/or country where published	T <sup>2</sup>
	NPL31	"Hewlett-Packard Journal," Hewlett-Packard Corporation, June 1989; 84 pages.	
	NPL32	HSU, ET AL., "Automatic Synthesis of Compression Techniques for Heterogeneous Files," Software - Practice and Experience, Vol. 25, No. 10, October 1995; pp. 1097-1116.	
	NPL33	"Guide to Sharing and Partitioning IBM Tape Library Dataservers," IBM International Technical Support Organization, San Jose Center, November 1996; 276 pages. (Submitted in 2 parts.)	
	NPL34	"Add-On Options for the XpressFiles," Intelligent Compression Technologies, 1998, accessible at < <a href="http://web.archive.org/web/19980518053418/ictcompress.com/options_X.html">http://web.archive.org/web/19980518053418/ictcompress.com/options_X.html</a> >; 2 pages.	
	NPL35	"Introducing XpressFiles," Intelligent Compression Technologies, 1998, accessible at < <a href="http://web.archive.org/web/19980518053310/ictcompress.com/xpressfiles.html">http://web.archive.org/web/19980518053310/ictcompress.com/xpressfiles.html</a> >; 1 page.	
	NPL36	"The Technology Behind XpressFiles," Intelligent Compression Technologies, 1998, accessible at < <a href="http://web.archive.org/web/19980518053634/ictcompress.com/technical_X.html">http://web.archive.org/web/19980518053634/ictcompress.com/technical_X.html</a> >; 1 page.	
	NPL37	XpressFiles White Paper, Intelligent Compression Technologies, 1999; 3 pages.	
	NPL38	"XML-Xpress Product Overview," Intelligent Compression Technologies, 2001, accessible at < <a href="http://web.archive.org/web/20020818002535/www.ictcompress.com/products_xmlxpress.html">http://web.archive.org/web/20020818002535/www.ictcompress.com/products_xmlxpress.html</a> >; 2 pages.	
	NPL39	"ICT's XML-Xpress," Intelligent Compression Technologies, December 2000; 6 pages.	
	NPL40	LARMOUTH, J., "ASN. 1 Complete," Open Systems Solutions, 1999; 387 pages. (Submitted in 4 parts.)	
Examiner Signature	/Tesfaldet Bocure/		Date Considered 04/18/2016

\*EXAMINER: Initial if reference considered, whether or not citation is in conformance with MPEP 609. Draw line through citation if not in conformance and not considered. Include copy of this form with next communication to applicant.

<sup>1</sup> Applicant's unique citation designation number (optional). <sup>2</sup> Applicant is to place a check mark here if English language Translation is attached.

ALL REFERENCES CONSIDERED EXCEPT WHERE LINED THROUGH. /T.B./

Substitute for form 1449/PTO		<b>Complete if Known</b>	
<b>FOURTH SUPPLEMENTAL INFORMATION DISCLOSURE STATEMENT BY APPLICANT</b> <i>(Use as many sheets as necessary)</i>		Application Number	14/876,276
		Filing Date	October 6, 2015
		First Named Inventor	James J. FALLON
		Art Unit	2634
		Examiner Name	BOCURE, TESFALDET
		Attorney Docket Number	3421.005000C
		Sheet	5

NON PATENT LITERATURE DOCUMENTS			
Examiner Initials*	Cite No. <sup>1</sup>	Include name of the author (in CAPITAL LETTERS), title of the article (when appropriate), title of the item (book, magazine, journal, serial, symposium, catalog, etc.), date, page(s), volume number, publisher, city and/or country where published	T <sup>2</sup>
	NPL41	"Magstar and IBM 3590 High Performance Tape Subsystem Technical Guide," IBM International Technical Support Organization, San Jose Center, November 1996; 287 pages. (Submitted in 2 parts.)	
	NPL42	McGREGOR, ET AL., "Performance Impact of Data Compression on Virtual Private Network Transactions," IEEE Proceedings of the 25th Annual Conference on Local Computer Networks, 2000; 11 pages.	
	NPL43	SUMMERS, B., "Official Microsoft NetMeeting Book," Redmond, WA: Microsoft Press, 1998; 374 pages. (Submitted in 5 parts.)	
	NPL44	BRITTON, ET AL., Discover Desktop Conferencing with NetMeeting 2.0, Foster City, CA: IDG Books Worldwide, Inc., 1998; 304 pages. (Submitted in 4 parts.)	
	NPL45	RANGANATHAN, N., "High-Speed VLSI Designs for Lempel-Ziv-Based Data Compression," IEEE Transactions on Circuits and Systems - II: Analog and Digital Signal Processing, Vol. 40, No. 2, February 1993; pp. 96-106.	
	NPL46	User's Guide, Sidewinder 50 AIT-1 Tape Drive, Seagate Technology, Inc., 1997; 19 pages.	
	NPL47	PROSISE, J., "Understanding Data Compression," PC Magazine, May 25, 1993; pp. 305-308.	
	NPL48	WELCH, T., Source Code, University of California, 1985; 23 pages.	
	NPL49	ABALI, ET AL., "Memory Expansion Technology (MXT): Software Support and Performance," IBM Journalist of Research and Development, Vol. 45, No. 2, March 2001; pp. 287-301.	
	NPL50	ANDERSON, ET AL., "Codec Squeezes Color Teleconferencing Through Digital Telephone Lines," Electronics, January 26, 1984; pp. 113-115.	

Examiner Signature	/Teskaldet Bocure/	Date Considered	04/18/2016
-----------------------	--------------------	--------------------	------------

\*EXAMINER: Initial if reference considered, whether or not citation is in conformance with MPEP 609. Draw line through citation if not in conformance and not considered. Include copy of this form with next communication to applicant.

<sup>1</sup> Applicant's unique citation designation number (optional). <sup>2</sup> Applicant is to place a check mark here if English language Translation is attached.

ALL REFERENCES CONSIDERED EXCEPT WHERE LINED THROUGH. /T.B./

Substitute for form 1449/PTO		<b>Complete if Known</b>	
<b>FOURTH SUPPLEMENTAL INFORMATION DISCLOSURE STATEMENT BY APPLICANT</b> <i>(Use as many sheets as necessary)</i>		Application Number	14/876,276
		Filing Date	October 6, 2015
		First Named Inventor	James J. FALLON
		Art Unit	2634
		Examiner Name	BOCURE, TESHALDET
		Attorney Docket Number	3421.005000C
Sheet	6	of	14

NON PATENT LITERATURE DOCUMENTS			
Examiner Initials*	Cite No. <sup>1</sup>	Include name of the author (in CAPITAL LETTERS), title of the article (when appropriate), title of the item (book, magazine, journal, serial, symposium, catalog, etc.), date, page(s), volume number, publisher, city and/or country where published	T <sup>2</sup>
	NPL51	COENE, ET AL., "A Fast Route For Application of Rate-Distortion Optimal Quantization in an MPEG Encoder," IEEE Proceedings of the International Conference on Image Processing, 1996; pp. 825-828.	
	NPL52	FRANASZEK, ET AL., "Algorithms and Data Structures for Compressed-Memory Machines," IBM Journal of Research and Development, Vol. 45, No. 2, March 2001; pp. 245-258.	
	NPL53	FRANASZEK, ET AL., "On Internal Organization in Compressed Random-Access Memories," IBM Journal of Research and Development, Vol. 45, No. 2, March 2001; pp. 259-270.	
	NPL54	IBM Technical Disclosure Bulletin, Vol. 38, No. 2, February 1995; 3 pages.	
	NPL55	"IBM Boosts Your Memory," Geek.com, accessible at < <a href="http://www.geek.com/ibm-boosts-your-memory/">http://www.geek.com/ibm-boosts-your-memory/</a> >, June 26, 2000; 3 pages.	
	NPL56	"IBM Research Breakthrough Doubles Computer Memory Capacity," IBM Press Release, June 26, 2000; 3 pages.	
	NPL57	IBM Technical Disclosure Bulletin, Vol. 37, No. 2B, February 1994; 3 pages.	
	NPL58	International Search Reports directed to International Patent Application Nos. PCT/US01/03711 and PCT/US01/03712, January 28, 2001 and May 10, 2002; 9 pages.	
	NPL59	MURASHITA, ET AL., "High-Speed Statistical Compression Using Self-Organized Rules and Predetermined Code Tables," IEEE Proceedings of Data Compression Conference, 1996; p. 449.	
	NPL60	RICE, ET AL., "Lossless Coding Standards for Space Data Systems," IEEE Conference Record of the Thirtieth Asilomar Conference on Signals, Systems and Computers, 1996; pp. 577-585.	

Examiner Signature	/Teshaldet Bocure/	Date Considered	04/18/2016
-----------------------	--------------------	--------------------	------------

\*EXAMINER: Initial if reference considered, whether or not citation is in conformance with MPEP 609. Draw line through citation if not in conformance and not considered. Include copy of this form with next communication to applicant.

<sup>1</sup> Applicant's unique citation designation number (optional). <sup>2</sup> Applicant is to place a check mark here if English language Translation is attached.

ALL REFERENCES CONSIDERED EXCEPT WHERE LINED THROUGH. /T.B./



Substitute for form 1449/PTO		<b>Complete if Known</b>	
<b>FOURTH SUPPLEMENTAL INFORMATION DISCLOSURE STATEMENT BY APPLICANT</b> <i>(Use as many sheets as necessary)</i>		Application Number	14/876,276
		Filing Date	October 6, 2015
		First Named Inventor	James J. FALLON
		Art Unit	2634
		Examiner Name	BOCURE, TESFALDET
		Attorney Docket Number	3421.005000C
Sheet	7	of	14

NON PATENT LITERATURE DOCUMENTS			
Examiner Initials*	Cite No. <sup>1</sup>	Include name of the author (in CAPITAL LETTERS), title of the article (when appropriate), title of the item (book, magazine, journal, serial, symposium, catalog, etc.), date, page(s), volume number, publisher, city and/or country where published	T <sup>2</sup>
	NPL61	RICE, R., "Some Practical Universal Noiseless Coding Techniques," National Aeronautics and Space Administration, JPL Publication 79-22, 1979; 149 pages.	
	NPL62	"ServerWorks To Deliver IBM's Memory eXpansion Technology in Next-Generation Core Logic for Servers," ServerWorks press release, accessible at < <a href="http://www.serverworks.com/news/press/000627.html">http://www.serverworks.com/news/press/000627.html</a> >, June 27, 2000; 1 page.	
	NPL63	SMITH, ET AL., "Memory Expansion Technology (MXT): Competitive Impact," IBM Journal of Research and Development, Vol. 45, No. 2, March 2001; pp. 303-309.	
	NPL64	TREMAINE, ET AL., "IBM Memory Expansion Technology (MXT)," IBM Journal of Research and Development, Vol. 45, No. 2, March 2001; pp. 271-285.	
	NPL65	VENBRUX, ET AL., "A VLSI Chip Set for High-Speed Lossless Data Compression," IEEE Transactions on Circuits and Systems for Video Technology, Vol. 2, No. 4, December 1992; pp. 381-391.	
	NPL66	YEH, P., "The CCSDS Lossless Data Compression Recommendation for Space Applications," Chapter 16, Lossless Compression Handbook, SAYOOD, K., ed., Academic Press, 2003; pp. 311-326.	
	NPL67	MARTIN, J., "HP drive offers data compression," COMPUTERWORLD, May 9, 1988; p. 76.	
	NPL68	MILLMAN, H., "Image and Video Compression," COMPUTERWORLD, January 18, 1999; p. 78.	
	NPL69	"MegaRam Disc Emulator: Revolutionary, Non-rotating, Solid-state Replacement for Fixed and Moving Head Discs," Imperial Technology, Inc., October 1985; 4 pages.	
	NPL70	"MegaRam-PC: Solid-State Disk Emulator For The IBM And IBM Compatible Personal Computers," Imperial Technology, Inc., October 1985; 2 pages.	

Examiner Signature	/Tesfaldet Bocure/	Date Considered	04/18/2016
-----------------------	--------------------	--------------------	------------

\*EXAMINER: Initial if reference considered, whether or not citation is in conformance with MPEP 609. Draw line through citation if not in conformance and not considered. Include copy of this form with next communication to applicant.

<sup>1</sup> Applicant's unique citation designation number (optional) <sup>2</sup> Applicant is to place a check mark here if English language Translation is attached.

ALL REFERENCES CONSIDERED EXCEPT WHERE LINED THROUGH. /T.B./

Substitute for form 1449/PTO		<i>Complete if Known</i>	
<b>FOURTH SUPPLEMENTAL INFORMATION DISCLOSURE STATEMENT BY APPLICANT</b> <i>(Use as many sheets as necessary)</i>		Application Number	14/876,276
		Filing Date	October 6, 2015
		First Named Inventor	James J. FALLON
		Art Unit	2634
		Examiner Name	BOCURE, TESFALDET
		Attorney Docket Number	3421.005000C
Sheet	8	of	14

NON PATENT LITERATURE DOCUMENTS			
Examiner Initials*	Cite No. <sup>1</sup>	Include name of the author (in CAPITAL LETTERS), title of the article (when appropriate), title of the item (book, magazine, journal, serial, symposium, catalog, etc.), date, page(s), volume number, publisher, city and/or country where published	T <sup>2</sup>
	NPL71	"MegaRam Solid State Disks," Imperial Technology, Inc., accessible via the Internet Archive at < <a href="https://web.archive.org/web/19990501183337/http://imperialtech.com/SolidState.html">https://web.archive.org/web/19990501183337/http://imperialtech.com/SolidState.html</a> >, May 1, 1999; 3 pages.	
	NPL72	"Quantum Rushmore Solid State Disk Drives," Quantum Corporation, accessible via the Internet Archive at < <a href="http://web.archive.org/web/19990508051125/http://www.quantum.com/products/ssd/">http://web.archive.org/web/19990508051125/http://www.quantum.com/products/ssd/</a> >, May 8, 1999; 3 pages.	
	NPL73	"Lucent Opts for Hi/fn Compression and Encryption In Latest Portmaster Products," PR Newswire, May 11, 1999; 2 pages.	
	NPL74	7711 to 7751 Migration Application Note, Hi/fn Network Security Processors, Application Note AN-0002-00, October 1, 1998; 8 pages.	
	NPL75	9705 Network Software Design Guide Application Note, Stac Electronics, Inc., APP-0012 Revision 1.0, May 1993; 30 pages.	
	NPL76	9705/9705A Data Compression Coprocessor Data Sheet, Hi/fn, May 1996; 87 pages.	
	NPL77	7711 to 7711 Migration Application Note, Hi/fn Network Security Processors, Application Note AN-0007-00, October 1, 1998; 7 pages.	
	NPL78	9732AM Data Compression Coprocessor Data Sheet, Hi/fn, PRS-0055 Revision 0.1, May 1999; 58 pages.	
	NPL79	BLELLOCH, G., "Algorithms in the Real World: Lecture Notes (Fall 1997)," Lecture Notes, UC Berkeley, April 23, 1998; 303 pages. (Submitted in 2 parts.)	
	NPL80	LeCUN, ET AL., "DjVu: a Compression Method for Distributing Scanned Documents in Color over the Internet," AT&T Labs-Research, January 1999; 2 pages.	

Examiner Signature	/Tefaldet Bocure/	Date Considered	04/18/2016
-----------------------	-------------------	--------------------	------------

\*EXAMINER: Initial if reference considered, whether or not citation is in conformance with MPEP 609. Draw line through citation if not in conformance and not considered. Include copy of this form with next communication to applicant.

<sup>1</sup> Applicant's unique citation designation number (optional). <sup>2</sup> Applicant is to place a check mark here if English language Translation is attached.

ALL REFERENCES CONSIDERED EXCEPT WHERE LINED THROUGH. /T.B./

Substitute for form 1449/PTO		<b>Complete if Known</b>	
<b>FOURTH SUPPLEMENTAL INFORMATION DISCLOSURE STATEMENT BY APPLICANT</b> <i>(Use as many sheets as necessary)</i>		Application Number	14/876,276
		Filing Date	October 6, 2015
		First Named Inventor	James J. FALLON
		Art Unit	2634
		Examiner Name	BOCURE, TESFALDET
		Attorney Docket Number	3421.005000C
Sheet	9	of	14

NON PATENT LITERATURE DOCUMENTS			
Examiner Initials*	Cite No. <sup>1</sup>	Include name of the author (in CAPITAL LETTERS), title of the article (when appropriate), title of the item (book, magazine, journal, serial, symposium, catalog, etc.), date, page(s), volume number, publisher, city and/or country where published	T <sup>2</sup>
	NPL81	9732A Data Compression Coprocessor Data Sheet, Hi/fn, October 1999; 50 pages.	
	NPL82	7711 Encryption Processor Data Sheet, Hi/fn Network Security Processors, June 1999; 77 pages.	
	NPL83	7751 Encryption Processor Data Sheet, Hi/fn Network Security Processors, June 1999; 84 pages.	
	NPL84	9751 Data Compression Processor Data Sheet, Hi/fn, June 1999; 66 pages.	
	NPL85	"Hi/fn Encryption Products Power Network Alchemy's Revolutionary VPN Products," Business Wire, January 26, 1999; 2 pages.	
	NPL86	"Hi/fn Provides Hardware Encryption for Xedia's New Access Point QPVN Internet Access Platform," Business Wire, October 19, 1998; 2 pages.	
	NPL87	"LZW Data Compression," Dr. Dobb's, October 1, 1989; 14 pages.	
	NPL88	"New Accelerator Chip From Hi/fn to Speed-Up Virtual Private Networks - 'VPNs'," Business Wire, January 26, 1999; 3 pages.	
	NPL89	Programming the 7711 For IPSEC Applications Application Note, Hi/fn Network Security Processors, Application Note AN-0002-00, October 1, 1998; 15 pages.	
	NPL90	FRIEND, R., "IP Payload Compression Using LZS, Request for Comments" The Internet Society, Network Working Group, Hi/fn, Inc., December 1998; 9 pages.	

Examiner Signature	/Tesfaldet Bocure/	Date Considered	04/18/2016
-----------------------	--------------------	--------------------	------------

\*EXAMINER: Initial if reference considered, whether or not citation is in conformance with MPEP 609. Draw line through citation if not in conformance and not considered. Include copy of this form with next communication to applicant.

<sup>1</sup> Applicant's unique citation designation number (optional). <sup>2</sup> Applicant is to place a check mark here if English language Translation is attached.

ALL REFERENCES CONSIDERED EXCEPT WHERE LINED THROUGH. /T.B./

Substitute for form 1449/PTO		<b>Complete if Known</b>	
<b>FOURTH SUPPLEMENTAL INFORMATION DISCLOSURE STATEMENT BY APPLICANT</b> <i>(Use as many sheets as necessary)</i>		Application Number	14/876,276
		Filing Date	October 6, 2015
		First Named Inventor	James J. FALLON
		Art Unit	2634
		Examiner Name	BOCURE, TESFALDET
		Attorney Docket Number	3421.005000C
Sheet	10	of	14

NON PATENT LITERATURE DOCUMENTS			
Examiner Initials*	Cite No. <sup>1</sup>	Include name of the author (in CAPITAL LETTERS), title of the article (when appropriate), title of the item (book, magazine, journal, serial, symposium, catalog, etc.), date, page(s), volume number, publisher, city and/or country where published	T <sup>2</sup>
	NPL91	Screenshot of hifn.com, accessible via the Internet Archive at < <a href="https://web.archive.org/web/19981212025553/http://www.hifn.com/">https://web.archive.org/web/19981212025553/http://www.hifn.com/</a> >, December 12, 1998; 1 page.	
	NPL92	WIRBEL, L., "Volume shipment for Hi/fn encryption processor," Electronic Engineering Times, Issue 1005, May 4, 1998; 2 pages.	
	NPL93	"Intelligent Compression Technologies: Intelligent Compression Technologies releases XML compressor, XML-Xpress," M2 Presswire, January 30, 2001; 5 pages.	
	NPL94	Form 10 - General Form for Registration of Securities, hi/fn, inc., United States Securities and Exchange Commission, filed December 8, 1998; 387 pages. (Submitted in 3 parts.)	
	NPL95	Form S-3 - Registration Statement Under The Securities Act of 1913, hi/fn, inc., United States Securities and Exchange Commission, filed February 17, 1999; 151 pages.	
	NPL96	HP 7979A/7980A/7980XC Tape Drive User's Guide, Hewlett-Packard Corporation, HP Computer Museum, October 1988; 76 pages.	
	NPL97	7980A Tape Drive - Documentation, HP Computer Museum, accessible at < <a href="http://www.hp-museum.net/exhibit.php?hwdoc=390">http://www.hp-museum.net/exhibit.php?hwdoc=390</a> >, September 22, 2015; 1 page.	
	NPL98	The HP 7980A/7979A 1/2-inch Tape Drives, Hewlett-Packard Product Specifications, June 1, 1987; 2 pages.	
	NPL99	9145A Tape Drive - Documentation, HP Computer Museum, accessible at < <a href="http://www.hp-museum.net/exhibit.php?hwdoc=258">http://www.hp-museum.net/exhibit.php?hwdoc=258</a> >, September 22, 2015; 1 page.	
	NPL100	HP 9145A Tape Drive User's Manual, Edition 1, Hewlett-Packard Corporation, July 1988; 61 pages.	

Examiner Signature	/Tefaldet Bocure/	Date Considered	04/18/2016
-----------------------	-------------------	--------------------	------------

\*EXAMINER: Initial if reference considered, whether or not citation is in conformance with MPEP 609. Draw line through citation if not in conformance and not considered. Include copy of this form with next communication to applicant.

<sup>1</sup> Applicant's unique citation designation number (optional). <sup>2</sup> Applicant is to place a check mark here if English language Translation is attached.

ALL REFERENCES CONSIDERED EXCEPT WHERE LINED THROUGH. /T.B./

Substitute for form 1449/PTO		<b>Complete if Known</b>	
<b>FOURTH SUPPLEMENTAL INFORMATION DISCLOSURE STATEMENT BY APPLICANT</b> <i>(Use as many sheets as necessary)</i>		Application Number	14/876,276
		Filing Date	October 6, 2015
		First Named Inventor	James J. FALLON
		Art Unit	2634
		Examiner Name	BOCURE, TESFALDET
		Attorney Docket Number	3421.005000C
Sheet	11	of	14

NON PATENT LITERATURE DOCUMENTS			
Examiner Initials*	Cite No. <sup>1</sup>	Include name of the author (in CAPITAL LETTERS), title of the article (when appropriate), title of the item (book, magazine, journal, serial, symposium, catalog, etc.), date, page(s), volume number, publisher, city and/or country where published	T <sup>2</sup>
	NPL101	Peripheral Products, HP Computer Museum, accessible at < <a href="http://www.hpmuseum.net/exhibit.php?class=4&amp;cat=85">http://www.hpmuseum.net/exhibit.php?class=4&amp;cat=85</a> >, September 22, 2015; 3 page.	
	NPL102	PALL, G., "Microsoft Point-To-Point Compression (MPPC) Protocol, Request for Comments," The Internet Society, Network Working Group, Hi/fn, Inc., December 1998; 9 pages.	
	NPL103	"Cisco IOS Data Compression," Cisco Systems White Paper, 1997; 10 pages.	
	NPL104	"Reference Software 7751 Encryption Processor," Hi/fn Network Security Processors, Reference Software RS-0001-00, October 1, 1998; 38 pages.	
	NPL105	Screenshot of hifn.com, accessible via the Internet Archive at < <a href="https://web.archive.org/web/19981205163011/http://www.hifn.com">https://web.archive.org/web/19981205163011/http://www.hifn.com</a> >, December 5, 1998; 1 page.	
	NPL106	TESS Record for Serial No. 78040025, filed December 20, 2000, "Typed Drawing," accessed November 10, 2015; 1 page.	
	NPL107	"Compaq Professional Workstation AP500 Key Technologies White Paper," Compaq Computer Corporation, August 1998; 21 pages.	
	NPL108	LANGDON, G., "An Introduction to Arithmetic Coding," IBM Journal of Research and Development, Vol. 28, No. 2, March 1984; pp. 135-149.	
	NPL109	"Connecting Your HP SureStore CD-Writer Plus Drive: Windows 95 and Windows NT 4.0," Hewlett-Packard Corporation, 1997; 50 pages.	
	NPL110	"Quantum Rushmore Solid State Disk Drives," Quantum Corporation, accessible via the Internet Archive at < <a href="http://web.archive.org/web/19980220122303/http://www.quantum.com/products/ssd/">http://web.archive.org/web/19980220122303/http://www.quantum.com/products/ssd/</a> >, February 20, 1998; 2 pages.	

Examiner Signature	/Tefaldet Bocure/	Date Considered	04/18/2016
-----------------------	-------------------	--------------------	------------

\*EXAMINER: Initial if reference considered, whether or not citation is in conformance with MPEP 609. Draw line through citation if not in conformance and not considered. Include copy of this form with next communication to applicant.

<sup>1</sup> Applicant's unique citation designation number (optional). <sup>2</sup> Applicant is to place a check mark here if English language Translation is attached.

ALL REFERENCES CONSIDERED EXCEPT WHERE LINED THROUGH. /T.B./

Substitute for form 1449/PTO		<i>Complete if Known</i>	
<b>FOURTH SUPPLEMENTAL INFORMATION DISCLOSURE STATEMENT BY APPLICANT</b> <i>(Use as many sheets as necessary)</i>		Application Number	14/876,276
		Filing Date	October 6, 2015
		First Named Inventor	James J. FALLON
		Art Unit	2634
		Examiner Name	BOCURE, TESFALDET
		Attorney Docket Number	3421.005000C
Sheet	12	of	14

NON PATENT LITERATURE DOCUMENTS			
Examiner Initials*	Cite No. <sup>1</sup>	Include name of the author (in CAPITAL LETTERS), title of the article (when appropriate), title of the item (book, magazine, journal, serial, symposium, catalog, etc.), date, page(s), volume number, publisher, city and/or country where published	T <sup>2</sup>
	NPL111	"MegaRam Solid State Disks," Imperial Technology, Inc., accessible via the Internet Archive at < <a href="https://web.archive.org/web/19980206055558/http://imperialtech.com/SolidState.html">https://web.archive.org/web/19980206055558/http://imperialtech.com/SolidState.html</a> >, February 6, 1998; 2 pages.	
	NPL112	"Replica - The Fastest, Most Reliable Data Protection For Servers," accessible via the Internet Archive at < <a href="http://web.archive.org/web/19970226213335/http://www1.stac.com/soft/replfct.html">http://web.archive.org/web/19970226213335/http://www1.stac.com/soft/replfct.html</a> >, February 26, 1997; 4 pages.	
	NPL113	"Object Replication: A Revolutionary Advance in Distributed Data Protection and Recovery," Stac White Paper, 1999; 7 pages.	
	NPL114	"Features and Benefits for Replica," Replica for NetWare, 1999; 3 pages.	
	NPL115	DjVu 2.2 Reference Library, August 2000 (submitted on compact disc).	
	NPL116	"Replica - The Fastest, Most Reliable Data Protection for Servers," accessible via the Internet Archive at < <a href="http://web.archive.org/web/19970226213335/http://www1.stac.com/soft/replcont.html">http://web.archive.org/web/19970226213335/http://www1.stac.com/soft/replcont.html</a> >, February 26, 1997; 1 page.	
	NPL117	"Stac Products & Technology," accessible via the Internet Archive at < <a href="http://web.archive.org/web/19970226213054/http://www1.stac.com/soft/softprod.html">http://web.archive.org/web/19970226213054/http://www1.stac.com/soft/softprod.html</a> >, February 26, 1997; 1 page.	
	NPL118	"Hi/fn Product Catalog," accessible via the Internet Archive at < <a href="http://web.archive.org/19971010233632/http://www.hifn.com/products/product/index.htm">http://web.archive.org/19971010233632/http://www.hifn.com/products/product/index.htm</a> >, October 10, 1997; 1 page.	
	NPL119	"Hi/fn Products," accessible via the Internet Archive at < <a href="http://web.archive.org/19971010233115/http://www.hifn.com/products/index.htm">http://web.archive.org/19971010233115/http://www.hifn.com/products/index.htm</a> >, October 10, 1997; 1 page.	
	NPL120	"Replica Family," accessible via the Internet Archive at < <a href="http://web.archive.org/19980212174817/http://www.stac.com/replica/rep_overview.html">http://web.archive.org/19980212174817/http://www.stac.com/replica/rep_overview.html</a> >, February 12, 1998; 1 page.	
Examiner Signature	/Tefaldet Bocure/		Date Considered 04/18/2016

\*EXAMINER: Initial if reference considered, whether or not citation is in conformance with MPEP 609. Draw line through citation if not in conformance and not considered. Include copy of this form with next communication to applicant.

<sup>1</sup> Applicant's unique citation designation number (optional). <sup>2</sup> Applicant is to place a check mark here if English language Translation is attached.

ALL REFERENCES CONSIDERED EXCEPT WHERE LINED THROUGH. /T.B./

Substitute for form 1449/PTO		<b>Complete if Known</b>	
<b>FOURTH SUPPLEMENTAL INFORMATION DISCLOSURE STATEMENT BY APPLICANT</b> <i>(Use as many sheets as necessary)</i>		Application Number	14/876,276
		Filing Date	October 6, 2015
		First Named Inventor	James J. FALLON
		Art Unit	2634
		Examiner Name	BOCURE, TESHALDET
		Attorney Docket Number	3421.005000C
Sheet	13	of	14

NON PATENT LITERATURE DOCUMENTS			
Examiner Initials*	Cite No. <sup>1</sup>	Include name of the author (in CAPITAL LETTERS), title of the article (when appropriate), title of the item (book, magazine, journal, serial, symposium, catalog, etc.), date, page(s), volume number, publisher, city and/or country where published	T <sup>2</sup>
	NPL121	"Stac Web Site Cotents," accessible via the Internet Archive at < <a href="http://web.archive.org/19990827224836/http://www.stac.com/subcontents/sitemap.asp?sitemap">http://web.archive.org/19990827224836/http://www.stac.com/subcontents/sitemap.asp?sitemap</a> >, August 27, 1999; 4 pages.	
	NPL122	"Data Compression Procedures for Data Circuit Terminating Equipment (DCE) Using Error Correcting Procedures," International Telecommunication Union Recommendation V.42 bis, 1990; 29 pages.	
	NPL123	Stac, Inc., News Articles, dated March 10, 1997 to February 2, 1999; 41 pages.	
	NPL124	Orost Archive of Welch Source Code, University of California, 1985; 54 pages.	
	NPL125	Sidewinder 50 Product Manual, Rev. A, Seagate Technology, Inc., 1997; 189 pages. (Submitted in 3 parts.)	
	NPL126	Form 10-Q Quarterly Report Pursuant to Section 13 or 15(d) of the Security Exchange Act of 1934, Stac Software, Inc., filed August 13, 1999; 16 pages.	
	NPL127	"Hi/Fn™ 7711 Encryption Processor™ Shipping in Volume," PR Newswire, April 20, 1998; 2 pages.	
	NPL128	"Lucent Technologies Selects," PR Newswire, March 1, 1999; 2 pages.	
	NPL129	"Stac backs it up with Replica," INFOSTOR, May 1, 1998; 2 pages.	
	NPL130	Court Docket History for Realtime Data, LLC d/b/a IXO v. Actian Corporation, et al., Case No. 6:15-cv-00463 (E.D. Texas), downloaded February 17, 2016, 29 pages.	

Examiner Signature	/Teshaldet Bocure/	Date Considered	04/18/2016
-----------------------	--------------------	--------------------	------------

\*EXAMINER: Initial if reference considered, whether or not citation is in conformance with MPEP 609. Draw line through citation if not in conformance and not considered. Include copy of this form with next communication to applicant.

<sup>1</sup> Applicant's unique citation designation number (optional). <sup>2</sup> Applicant is to place a check mark here if English language Translation is attached.

ALL REFERENCES CONSIDERED EXCEPT WHERE LINED THROUGH. /T.B./

Substitute for form 1449/PTO		<b>Complete if Known</b>	
<b>FOURTH SUPPLEMENTAL INFORMATION DISCLOSURE STATEMENT BY APPLICANT</b> <i>(Use as many sheets as necessary)</i>		Application Number	14/876,276
		Filing Date	October 6, 2015
		First Named Inventor	James J. FALLON
		Art Unit	2634
		Examiner Name	BOCURE, TESFALDET
		Attorney Docket Number	3421.005000C
Sheet	14	of	14

NON PATENT LITERATURE DOCUMENTS			
Examiner Initials*	Cite No. <sup>1</sup>	Include name of the author (in CAPITAL LETTERS), title of the article (when appropriate), title of the item (book, magazine, journal, serial, symposium, catalog, etc.), date, page(s), volume number, publisher, city and/or country where published	T <sup>2</sup>
	NPL131	Court Docket History for Realtime Data, LLC d/b/a IXO v. Dropbox, Inc., Case No. 6:15-cv-00465 (E.D. Texas), downloaded February 17, 2016, 6 pages.	
	NPL132	Court Docket History for Realtime Data, LLC d/b/a IXO v. Echostar Corporation, et al., Case No. 6:15-cv-00466 (E.D. Texas), downloaded February 17, 2016, 3 pages.	
	NPL133	Court Docket History for Realtime Data, LLC d/b/a IXO v. Riverbed Technology, Inc., et al., Case No. 6:15-cv-00468 (E.D. Texas), downloaded February 17, 2016, 3 pages.	
	NPL134	Court Docket History for Realtime Data, LLC d/b/a IXO v. BMC Software, Inc., Case No. 6:15-cv-00464 (E.D. Texas), downloaded February 17, 2016, 3 pages.	
	NPL135	Court Docket History for Realtime Data, LLC d/b/a IXO v. Oracle America, Inc., et al., Case No. 6:15-cv-00467 (E.D. Texas), downloaded February 17, 2016, 4 pages.	
	NPL136	Court Docket History for Realtime Data, LLC d/b/a IXO v. SAP America, Inc., et al., Case No. 6:15-cv-00469 (E.D. Texas), downloaded February 17, 2016, 5 pages.	
	NPL137	Court Docket History for Realtime Data, LLC d/b/a IXO v. Teradata Corporation, et al., Case No. 6:15-cv-00470 (E.D. Texas), downloaded February 17, 2016, 6 pages.	
	NPL138	Court Docket History for Realtime Data, LLC d/b/a IXO v. Apple, Inc., Case No. 6:15-cv-00885 (E.D. Texas), downloaded February 17, 2016, 6 pages.	

2774134\_1.DOCX


Examiner Signature	/Tsfaldet Bocure/	Date Considered	04/18/2016
-----------------------	-------------------	--------------------	------------

\*EXAMINER: Initial if reference considered, whether or not citation is in conformance with MPEP 609. Draw line through citation if not in conformance and not considered. Include copy of this form with next communication to applicant.

<sup>1</sup> Applicant's unique citation designation number (optional). <sup>2</sup> Applicant is to place a check mark here if English language Translation is attached.

ALL REFERENCES CONSIDERED EXCEPT WHERE LINED THROUGH. /T.B./



<b>Index of Claims</b>  	<b>Application/Control No.</b> 14876276	<b>Applicant(s)/Patent Under Reexamination</b> FALLON ET AL.
	<b>Examiner</b> TESFALDET BOCURE	<b>Art Unit</b> 2634

✓	<b>Rejected</b>	-	<b>Cancelled</b>	N	<b>Non-Elected</b>	A	<b>Appeal</b>
=	<b>Allowed</b>	÷	<b>Restricted</b>	I	<b>Interference</b>	O	<b>Objected</b>

<input checked="" type="checkbox"/> Claims renumbered in the same order as presented by applicant		<input type="checkbox"/> CPA		<input type="checkbox"/> T.D.		<input type="checkbox"/> R.1.47	
CLAIM		DATE					
Final	Original	01/23/2016	04/18/2016				
1	1	✓	=				
2	2	✓	=				
3	3	✓	=				
4	4	✓	=				
5	5	✓	=				
6	6	✓	=				
7	7	✓	=				
8	8	✓	=				
9	9	✓	=				
10	10	✓	=				
11	11	✓	=				
12	12	✓	=				
13	13	✓	=				
14	14	✓	=				
15	15	✓	=				
16	16	✓	=				
17	17	✓	=				
18	18	✓	=				
19	19	✓	=				
20	20	✓	=				
21	21	✓	=				
22	22	✓	=				
23	23	✓	=				
24	24	✓	=				
25	25	✓	=				
26	26	✓	=				
27	27	✓	=				
28	28	✓	=				
29	29	✓	=				
30	30	✓	=				

## WEST Search History for Application 14876276

Creation Date: 2016041808:24

### Prior Art Searches

Query	DB	Hits	Op.	Plur.	Thes.	Date
((Fallen adj James).in. or (McErlain adj Stephen).in.)	PGPB, USPT, USOC, EPAB, JPAB, DWPI, TDBD	n/a	OR	YES		04-18-2016
((Fallen).in. or (McErlain).in.)	PGPB, USPT, USOC, EPAB, JPAB, DWPI, TDBD	n/a	OR	YES		04-18-2016
(select\$4 or choos\$4) near4 ((multiple or plural\$4 or two or three or four or five) near5 encoder\$) same ((assymetric\$ or (lempel adj2 ziv)) near4 (compressing or compression))	PGPB, USPT, USOC, EPAB, JPAB, DWPI, TDBD	n/a	OR	YES		04-18-2016
(select\$4 or choos\$4) near4 ((multiple or plural\$4 or two or three or four or five) near5 encoder\$) and ((assymetric\$ or (lempel adj2 ziv)) near4 (compressing or compression))	PGPB, USPT, USOC, EPAB, JPAB, DWPI, TDBD	n/a	OR	YES		04-18-2016
((select\$4 or choos\$4) near4 ((multiple or plural\$4 or two or three or four or five) near5 encoder\$) and ((assymetric\$ or (lempel adj2 ziv)) near4 (compressing or compression))) and @ad<=20010213	PGPB, USPT, USOC, EPAB, JPAB, DWPI, TDBD	n/a	OR	YES		04-18-2016
((select\$4 or choos\$4) near4 ((multiple or plural\$4 or two or three or four or five) near5 encoder\$) and ((assymetric\$ or (lempel adj2 ziv)) near4	PGPB, USPT, USOC,	n/a	OR	YES		04-18-2016

<b>((compressing or compression)) ) and ( (((Fallen adj James).in. or (McErlain adj Stephen).in.) ) or (((Fallen).in. or (McErlain).in.) ) )</b>	EPAB, JPAB, DWPI, TDBD					
<b>((select\$4 or choos\$4) near4 ((multiple or plural\$4 or two or three or four or five) near5 encoder\$) and ((assymetric\$ or (lempel adj2 ziv)) near4 (compressing or compression)) ) and ( (((Fallen adj James).in. or (McErlain adj Stephen).in.) ) )</b>	PGPB, USPT, USOC, EPAB, JPAB, DWPI, TDBD	n/a	OR	YES		04-18-2016
<b>(selecting or select or choose or choosing) near4 ((compress or compression or compressing) near4 (algorithm or algorithms or mode or modes)) same ((assymetric\$4 or (lempel adj2 ziv)) near4 (compressing or compression))</b>	PGPB, USPT, USOC, EPAB, JPAB, DWPI, TDBD	n/a	OR	YES		04-18-2016
<b>((compress or compression or compressing) near4 (algorithm or algorithms or mode or modes)) same (parameter or parameters or attribute or attributes) same (assymetric \$4near4 (compressing or compression))</b>	PGPB, USPT, USOC, EPAB, JPAB, DWPI, TDBD	n/a	OR	YES		04-18-2016
<b>((compress or compression or compressing) near4 (algorithm or algorithms or mode or modes)) same (parameter or parameters or attribute or attributes) same (assymetric\$4 near4 (compressing or compression))</b>	PGPB, USPT, USOC, EPAB, JPAB, DWPI, TDBD	n/a	OR	YES		04-18-2016
<b>((compress or compression or compressing) near4 (algorithm or algorithms or mode or modes)) same (parameter or parameters or attribute or attributes) same ((fast near4 slow) near4 (compressing or compression))</b>	PGPB, USPT, USOC, EPAB, JPAB, DWPI, TDBD	n/a	OR	YES		04-18-2016
<b>((multiple or plural\$4 or two or three or four or five) near5 encoder\$) same ((assymetric\$ or (lempel adj2 ziv)) near4 (compressing or compression))</b>	PGPB, USPT, USOC, EPAB, JPAB, DWPI, TDBD	n/a	OR	YES		04-18-2016

<p>((selecting or select or choose or choosing) near4 ((compress or compression or compressing) near4 (algorithm or algorithms or mode or modes)) same ((assymetric\$4 or (lempel adj2 ziv)) near4 (compressing or compression)) ) and (((H03M7/30)))   (((H03M7/3084)))   (((H03M7/6094)))   (((G06F15/7867)))   (((G06T1/60)))   (((H04N19/136))).CPC. )</p>	PGPB, USPT, USOC, EPAB, JPAB, DWPI, TDBD	n/a	OR	YES		04-18-2016
<p>(((multiple or plural\$4 or two or three or four or five) near5 encoder\$) same ((assymetric\$ or (lempel adj2 ziv)) near4 (compressing or compression)) ) and (((H03M7/30)))   (((H03M7/3059)))   (((H03M7/3093)))   (((H04L69/04)))   (((H04N19/152)))   (((H04N9/8042))).CPC. )</p>	PGPB, USPT, USOC, EPAB, JPAB, DWPI, TDBD	n/a	OR	YES		04-18-2016
<p>("20010019630"   "20010031092"   "20010032128"   "20010047473"   "20010052038"   "20020037035"   "20020069354"   "20020078241"   "20020080871"   "20020097172"   "20020101367"   "20020104891"   "20020126755"   "20020169950"   "20020191692"   "20030030575"   "20030034905"   "20030058873"   "20030084238").PN.</p>	PGPB, USPT, USOC, EPAB, JPAB, DWPI, TDBD	n/a	OR	YES		04-18-2016
<p>(((375/\$8)).ccls. or ((370/\$8)).ccls. or ((348/\$8)).ccls. or ((341/\$8)).ccls. or ((711/\$8)).ccls. or ((701/\$8)).ccls. or ((381/\$8)).ccls. or ((375/382)).ccls. )</p>	PGPB, USPT, USOC, EPAB, JPAB, DWPI, TDBD	n/a	OR	YES		04-18-2016
<p>(((375/\$8)).ccls. or ((370/\$8)).ccls. or ((348/\$8)).ccls. or ((341/\$8)).ccls. or ((711/\$8)).ccls. or ((701/\$8)).ccls. or ((381/\$8)).ccls. or ((375/382)).ccls. ) and ( ((select\$4 or choos\$4) near4 ((multiple or plural\$4 or two or three or four or five) near5 encoder\$) and ((assymetric\$ or (lempel adj2 ziv)) near4 (compressing or compression)) ) or ((selecting or select or choose or choosing) near4 ((compress or compression or compressing) near4 (algorithm or algorithms or mode or modes)) same ((assymetric\$4 or (lempel adj2 ziv)) near4 (compressing or compression)) ) or (((multiple or plural\$4 or two or three or four or five) near5 encoder\$) same ((assymetric\$ or (lempel adj2 ziv)) near4 (compressing or compression)) ) )</p>	PGPB, USPT, USOC, EPAB, JPAB, DWPI, TDBD	n/a	OR	YES		04-18-2016
<p>(((375/240)).ccls. or ((375/240.01)).ccls. or ((375/240.02)).ccls. or ((341/50)).ccls. or ((341/51)).ccls. or ((341/126)).ccls. ) and ( ((select\$4</p>	PGPB, USPT, USOC,	n/a	OR	YES		04-18-2016

<p>or choos\$4) near4 ((multiple or plural\$4 or two or three or four or five) near5 encoder\$) and ((assymetric\$ or (lempel adj2 ziv)) near4 (compressing or compression)) ) or ((selecting or select or choose or choosing) near4 ((compress or compression or compressing) near4 (algorithm or algorithms or mode or modes)) same ((assymetric\$4 or (lempel adj2 ziv)) near4 (compressing or compression)) ) or (((multiple or plural\$4 or two or three or four or five) near5 encoder\$) same ((assymetric\$ or (lempel adj2 ziv)) near4 (compressing or compression)) ) )</p>	<p>EPAB, JPAB, DWPI, TDBD</p>					
<p>((multiple or plural\$4 or two or three or four or five) near5 encoder\$) same ((assymetric\$3 or (lempel adj2 ziv) and (arithmetic)) near4 (compressing or compression))</p>	<p>PGPB, USPT, USOC, EPAB, JPAB, DWPI, TDBD</p>	<p>n/a</p>	<p>OR</p>	<p>YES</p>		<p>04-18-2016</p>
<p>( ((select\$4 or choos\$4) near4 ((multiple or plural\$4 or two or three or four or five) near5 encoder\$) and ((assymetric\$ or (lempel adj2 ziv)) near4 (compressing or compression)) ) or ((selecting or select or choose or choosing) near4 ((compress or compression or compressing) near4 (algorithm or algorithms or mode or modes)) same ((assymetric\$4 or (lempel adj2 ziv)) near4 (compressing or compression)) ) or (((multiple or plural\$4 or two or three or four or five) near5 encoder\$) same ((assymetric\$ or (lempel adj2 ziv)) near4 (compressing or compression)) ) or (((multiple or plural\$4 or two or three or four or five) near5 encoder\$) same ((assymetric\$3 or (lempel adj2 ziv) and (arithmetic)) near4 (compressing or compression)) ) )</p>	<p>PGPB, USPT, USOC, EPAB, JPAB, DWPI, TDBD</p>	<p>n/a</p>	<p>OR</p>	<p>YES</p>		<p>04-18-2016</p>
<p>(((select\$4 or choos\$4) near4 ((multiple or plural\$4 or two or three or four or five) near5 encoder\$) and ((assymetric\$ or (lempel adj2 ziv)) near4 (compressing or compression)) or (selecting or select or choose or choosing) near4 ((compress or compression or compressing) near4 (algorithm or algorithms or mode or modes)) same ((assymetric\$4 or (lempel adj2 ziv)) near4 (compressing or compression)) or ((multiple or plural\$4 or two or three or four or five) near5 encoder\$) same ((assymetric\$ or (lempel adj2 ziv)) near4 (compressing or compression)) or ((multiple or plural\$4 or two or three or four or five) near5 encoder\$) same ((assymetric\$3 or (lempel adj2 ziv) and (arithmetic)) near4 (compressing or compression)) ) )</p>	<p>PGPB, USPT, USOC, EPAB, JPAB, DWPI, TDBD</p>	<p>n/a</p>	<p>OR</p>	<p>YES</p>		<p>04-18-2016</p>

<p>and (arithmetic)) near4 (compressing or compression)) ) ) and (((375/240)).ccls. or ((375/240.01)).ccls. or ((375/240.02)).ccls. or ((341/50)).ccls. or ((341/51)).ccls. or ((341/126)).ccls. ) and ((select\$4 or choos\$4) near4 ((multiple or plural\$4 or two or three or four or five) near5 encoder\$) and ((assymetric\$ or (lempel adj2 ziv)) near4 (compressing or compression)) or (selecting or select or choose or choosing) near4 ((compress or compression or compressing) near4 (algorithm or algorithms or mode or modes)) same ((assymetric\$4 or (lempel adj2 ziv)) near4 (compressing or compression)) or ((multiple or plural\$4 or two or three or four or five) near5 encoder\$) same ((assymetric\$ or (lempel adj2 ziv)) near4 (compressing or compression)) ) )</p>						
<p>(((select\$4 or choos\$4) near4 ((multiple or plural\$4 or two or three or four or five) near5 encoder\$) and ((assymetric\$ or (lempel adj2 ziv)) near4 (compressing or compression)) or (selecting or select or choose or choosing) near4 ((compress or compression or compressing) near4 (algorithm or algorithms or mode or modes)) same ((assymetric\$4 or (lempel adj2 ziv)) near4 (compressing or compression)) or ((multiple or plural\$4 or two or three or four or five) near5 encoder\$) same ((assymetric\$ or (lempel adj2 ziv)) near4 (compressing or compression)) or ((multiple or plural\$4 or two or three or four or five) near5 encoder\$) same ((assymetric\$3 or (lempel adj2 ziv)) and (arithmetic)) near4 (compressing or compression)) ) ) and (((375/\$8)).ccls. or ((370/\$8)).ccls. or ((348/\$8)).ccls. or ((341/\$8)).ccls. or ((711/\$8)).ccls. or ((701/\$8)).ccls. or ((381/\$8)).ccls. or ((375/382)).ccls. ) )</p>	PGPB, USPT, USOC, EPAB, JPAB, DWPI, TDBD	n/a	OR	YES		04-18-2016
<p>(((select\$4 or choos\$4) near4 ((multiple or plural\$4 or two or three or four or five) near5 encoder\$) and ((assymetric\$ or (lempel adj2 ziv)) near4 (compressing or compression)) or (selecting or select or choose or choosing) near4 ((compress or compression or compressing) near4 (algorithm or algorithms or mode or modes)) same ((assymetric\$4 or (lempel adj2 ziv)) near4 (compressing or compression)) or ((multiple or plural\$4 or two or three or four or five) near5 encoder\$) same ((assymetric\$ or (lempel adj2 ziv)) near4 (compressing or compression)) or ((multiple or plural\$4 or two or three or four or five) near5 encoder\$) same ((assymetric\$3 or (lempel adj2 ziv))</p>	PGPB, USPT, USOC, EPAB, JPAB, DWPI, TDBD	n/a	OR	YES		04-18-2016

<p>and (arithmetic)) near4 (compressing or compression)) ) and (((H03M7/30)   (H03M7/3059)   (H03M7/3084)   (H03M7/6094)   (H03M7/3088)   (H03M7/6023)   (H03M7/6064)   (H04N19/152)   (G11B20/00007)).CPC. )</p>						
<p>("20150334390"   "3394352"   "3490690"   "4021782"   "4032893"   "4054951"   "4127518"   "4302775"   "4325085"   "4360840"   "4386416"   "4394774"   "4464650"   "4494108"   "4499499"   "4574351"   "4626829"   "4646061"   "4682150"   "4701745").PN.</p>	<p>PGPB, USPT, USOC, EPAB, JPAB, DWPI, TDBD</p>	<p>n/a</p>	<p>OR</p>	<p>YES</p>		<p>04-18-2016</p>
<p>((("20150334390"   "3394352"   "3490690"   "4021782"   "4032893"   "4054951"   "4127518"   "4302775"   "4325085"   "4360840"   "4386416"   "4394774"   "4464650"   "4494108"   "4499499"   "4574351"   "4626829"   "4646061"   "4682150"   "4701745").PN. ) and (((select\$4 or choos\$4) near4 ((multiple or plural\$4 or two or three or four or five) near5 encoder\$) and ((assymetric\$ or (lempel adj2 ziv)) near4 (compressing or compression)) or (selecting or select or choose or choosing) near4 ((compress or compression or compressing) near4 (algorithm or algorithms or mode or modes)) same ((assymetric\$4 or (lempel adj2 ziv)) near4 (compressing or compression)) or ((multiple or plural\$4 or two or three or four or five) near5 encoder\$) same ((assymetric\$ or (lempel adj2 ziv)) near4 (compressing or compression)) or ((multiple or plural\$4 or two or three or four or five) near5 encoder\$) same ((assymetric\$3 or (lempel adj2 ziv) and (arithmetic)) near4 (compressing or compression)) ) )</p>	<p>PGPB, USPT, USOC, EPAB, JPAB, DWPI, TDBD</p>	<p>1</p>	<p>OR</p>	<p>YES</p>		<p>04-18-2016</p>

Under the Paperwork Reduction Act of 1995, no persons are required to respond to a collection of information unless it contains a valid OMB control number.

<b>Request for Continued Examination (RCE) Transmittal</b>  Address to: Mail Stop RCE Commissioner for Patents P.O. Box 1450 Alexandria, VA 22313-1450	Application Number	14/876,276
	Filing Date	October 6, 2015
	First Named Inventor	James J. FALLON
	Art Unit	2634
	Examiner Name	BOCURE, TESFALDET
	Attorney Docket Number	3421.005000C

**This is a Request for Continued Examination (RCE) under 37 CFR 1.114 of the above-identified application.**  
 Request for Continued Examination (RCE) practice under 37 CFR 1.114 does not apply to any utility or plant application filed prior to June 8, 1995, or to any design application. See Instruction Sheet for RCEs (not to be submitted to the USPTO) on page 2.

1. **Submission required under 37 CFR 1.114** Note: If the RCE is proper, any previously filed unentered amendments and amendments enclosed with the RCE will be entered in the order in which they were filed unless applicant instructs otherwise. If applicant does not wish to have any previously filed unentered amendment(s) entered, applicant must request non-entry of such amendment(s).

a.  Previously submitted. If a final Office action is outstanding, any amendments filed after the final Office action may be considered as a submission even if this box is not checked.

    i.  Consider the arguments in the Appeal Brief or Reply Brief previously filed on \_\_\_\_\_

    ii.  Other \_\_\_\_\_

b.  Enclosed

    i.  Amendment/Reply

    ii.  Affidavit(s)/ Declaration(s)

    iii.  Information Disclosure Statement (IDS)

    iv.  Other \_\_\_\_\_

2. **Miscellaneous**

a.  Suspension of action on the above-identified application is requested under 37 CFR 1.103(c) for a period of \_\_\_\_\_ months. (Period of suspension shall not exceed 3 months; Fee under 37 CFR 1.17(i) required)

b.  Other \_\_\_\_\_

3. **Fees** The RCE fee under 37 CFR 1.17(e) is required by 37 CFR 1.114 when the RCE is filed. The Director is hereby authorized to charge the following fees, any underpayment of fees, or credit any overpayments, to Deposit Account No. 19-0036

a.  RCE fee required under 37 CFR 1.17(e)

    ii.  Extension of time fee (37 CFR 1.136 and 1.17)

    iii.  Other \_\_\_\_\_

b.  Check in the amount of \$ \_\_\_\_\_ enclosed

c.  Payment by credit card (Form PTO-2038 enclosed)

**WARNING: Information on this form may become public. Credit card information should not be included on this form. Provide credit card information and authorization on PTO-2038.**

SIGNATURE OF APPLICANT, ATTORNEY, OR AGENT REQUIRED			
Signature		Date	10/16/2015
Name (Print/Type)	Michael V. Messinger	Registration No.	37,575

CERTIFICATE OF MAILING OR TRANSMISSION			
I hereby certify that this correspondence is being deposited with the United States Postal Service with sufficient postage as first class mail in an envelope addressed to: Mail Stop RCE, Commissioner for Patents, P. O. Box 1450, Alexandria, VA 22313-1450 or facsimile transmitted to the U.S. Patent and Trademark Office on the date shown below.			
Signature		Date	
Name (Print/Type)			

This collection of information is required by 37 CFR 1.114. The information is required to obtain or retain a benefit by the public which is to file (and by the USPTO to process) an application. Confidentiality is governed by 35 U.S.C. 122 and 37 CFR 1.11 and 1.14. This collection is estimated to take 12 minutes to complete, including gathering, preparing, and submitting the completed application form to the USPTO. Time will vary depending upon the individual case. Any comments on the amount of time you require to complete this form and/or suggestions for reducing this burden, should be sent to the Chief Information Officer, U.S. Patent and Trademark Office, U.S. Department of Commerce, P.O. Box 1450, Alexandria, VA 22313-1450. DO NOT SEND FEES OR COMPLETED FORMS TO THIS ADDRESS. **SEND TO: Mail Stop RCE, Commissioner for Patents, P.O. Box 1450, Alexandria, VA 22313-1450.**

If you need assistance in completing the form, call 1-800-PTO-9199 and select option 2.



IN THE UNITED STATES PATENT AND TRADEMARK OFFICE

Inventors: FALLON *et al.*

Confirmation No.: 3403

Applicant: Realtime Data, LLC

Art Unit: 2634

Application No.: 14/876,276

Examiner: BOCURE, TEFALDET

Filing Date: October 6, 2015

Atty. Docket: 3421.005000C

Title: **Video Data Compression Systems**

**Sixth Supplemental Information Disclosure Statement**

*Mail Stop RCE*

Commissioner for Patents  
PO Box 1450  
Alexandria, VA 22313-1450

Commissioner:

Notice of Prior and Concurrent Proceedings

Applicant hereby calls to the attention of the Patent and Trademark Office the following reexamination proceedings involving patents that are commonly-assigned with the patent in the above-identified patent application:

<b>Proceeding</b>	<b>Status</b>
Inter Partes Reexamination of U.S. Patent No. 6,604,158 (Control No. 95/000,486)	Inter Partes Reexamination Certificate issued 10/10/2012
Inter Partes Reexamination of U.S. Patent No. 7,321,937 (Control No. 95/000,466)	Inter Partes Reexamination Certificate issued 05/15/2012
Inter Partes Reexamination of U.S. Patent No. 6,604,158 (Control No. 95/000,453)	Terminated
Ex Parte Reexamination of U.S. Patent No. 6,601,104 (Control No. 90/009,428)	Ex Parte Reexamination Certificate issued 02/28/2012
Inter Partes Reexamination of U.S. Patent No. 7,378,992 (Control No. 95/000,478)	Inter Partes Reexamination Certificate issued 10/04/2012
Inter Partes Reexamination of U.S. Patent No. 6,624,761 (Control No. 95/000,464)	Inter Partes Reexamination Certificate issued 06/12/2012
Inter Partes Reexamination of U.S. Patent No. 7,161,506 (Control No. 95/000,479)	Inter Partes Reexamination Certificate issued 05/22/2012

<b>Proceeding</b>	<b>Status</b>
Inter Partes Reexamination of U.S. Patent No. 7,714,747 (Control No. 95/001,517)	Appeal to the Court of Appeals for the Federal Circuit dismissed 6/4/2015
Inter Partes Reexamination of U.S. Patent No. 7,417,568 (Control No. 95/001,533)	Decision on Appeal mailed 10/29/2015
Inter Partes Reexamination of U.S. Patent No. 7,777,651 (Control No. 95/001,581)	Decision on Appeal mailed 10/29/2015
Inter Partes Reexamination of U.S. Patent No. 7,400,274 (Control No. 95/001,544)	Decision on Appeal mailed 10/29/2015

Applicant hereby calls to the attention of the Patent and Trademark Office the following reexamination proceedings filed by Cellco Partnership d/b/a Verizon Wireless, involving patents that are commonly-assigned with the patent in the above-identified patent application:

<b>Proceeding</b>	<b>Status</b>
Inter Partes Reexamination of U.S. Patent No. 7,321,937 (Control No. 95/001,922)	Inter Partes Reexamination Certificate issued 12/05/2013
Inter Partes Reexamination of U.S. Patent No. 6,604,158 (Control No. 95/001,923)	Inter Partes Reexamination Certificate issued 04/17/2015
Inter Partes Reexamination of U.S. Patent No. 7,352,300 (Control No. 95/001,924)	Inter Partes Reexamination Certificate issued 08/04/2014
Inter Partes Reexamination of U.S. Patent No. 7,395,345 (Control No. 95/001,925)	Inter Partes Reexamination Certificate issued 11/03/2014
Inter Partes Reexamination of U.S. Patent No. 7,161,506 (Control No. 95/001,926)	Inter Partes Reexamination Certificate issued 01/08/2014
Inter Partes Reexamination of U.S. Patent No. 7,415,530 (Control No. 95/001,927)	Inter Partes Reexamination Certificate issued 08/16/2013
Inter Partes Reexamination of U.S. Patent No. 7,378,992 (Control No. 95/001,928)	Inter Partes Reexamination Certificate issued 01/08/2014

Applicant invites the Examiner to review the Requests for Reexamination, issued Office Actions, replies, and any other papers in the above-identified reexamination proceedings. If the Examiner is unable to obtain copies of papers in any reexamination proceeding, copies can be

Atty. Dkt. No. 3421.005000C

provided to the Examiner upon request. Those documents which may be material that are not already of record in this patent application are listed on the accompanying Form PTO/SB/08.

Applicant hereby calls to the attention of the Patent and Trademark Office the following *inter partes* review proceedings involving patents that are commonly-assigned with the patent in the above-identified patent application:

<b>Proceeding</b>	<b>Patent</b>	<b>Status</b>
<i>Oracle America, Inc. v. Realtime Data, LLC</i> , IPR2016-00373	7,378,992	Patent Owner Preliminary Response filed April 7, 2016
<i>Oracle America, Inc. v. Realtime Data, LLC</i> , IPR2016-00374	8,643,513	Patent Owner Preliminary Response filed April 8, 2016
<i>Oracle America, Inc. v. Realtime Data, LLC</i> , IPR2016-00375	7,415,530	Patent Owner Preliminary Response filed April 11, 2016
<i>Oracle America, Inc. v. Realtime Data, LLC</i> , IPR2016-00376	7,415,530	Patent Owner Preliminary Response filed April 11, 2016
<i>Oracle America, Inc. v. Realtime Data, LLC</i> , IPR2016-00377	9,116,908	Patent Owner Preliminary Response filed April 11, 2016
<i>SAP America Inc., et al. v. Realtime Data, LLC d/b/a IXO</i> , IPR2016-00783	6,597,812	Petition filed April 1, 2016
<i>Dell Inc., et al. v. Realtime Data, LLC</i> , IPR2016-00878	7,415,530	Petition filed April 22, 2016
<i>Dell Inc., et al. v. Realtime Data, LLC</i> , IPR2016-00972	7,415,530	Petition filed April 29, 2016
<i>Riverbed Technology, Inc. et al. v. Realtime Data, LLC</i> , IPR2016-00978	8,643,513	Petition filed April 29, 2016
<i>Riverbed Technology, Inc. et al. v. Realtime Data, LLC</i> , IPR2016-00980	7,378,992	Petition filed April 29, 2016
<i>Dell Inc., et al. v. Realtime Data, LLC</i> , IPR2016-01002	9,116,908	Petition filed May 5, 2016

Applicant invites the Examiner to review the petitions for *inter partes* review and any other papers in the above-identified *inter partes* review proceedings. If the Examiner is unable to obtain copies of papers in any *inter partes* review proceeding, copies can be provided to the Examiner upon request. Those documents which may be material that are not already of record in this patent application are listed on the accompanying Form PTO/SB/08 as documents **US1-US2, FP1-FP2,** and **NPL8-NPL19.**

Notice of Related Litigation

Applicant notifies the Patent and Trademark Office of the following litigation involving U.S. Patents commonly-owned with the current patent application, the subject matter of which may be related to the present patent application:

No.	Case	Status
1	<i>Realtime Data LLC d/b/a IXO v. Packeteer, Inc. et al.</i> , No. 6:08-cv-00144-LED (E.D. Texas)	Dismissed

Applicant also notifies the Patent and Trademark Office of the following additional litigation involving U.S. Patents commonly-owned with the current patent application, the subject matter of which may be related to the present patent application:

No.	Case	Status
2	<i>Realtime Data LLC d/b/a IXO v. Thomson Reuters Corporation et al.</i> No. 1:11-cv-06698-RJH (S.D. New York) (transferred from E.D. Texas; 6:09-cv-00333-LED)	Case Terminated 11/9/2012; Opinion of the Court of Appeals for the Federal Circuit received 01/27/2014

3	<i>Realtime Data LLC d/b/a IXO v. Morgan Stanley et al.</i> , No. 1:11-cv-06696-RJH (S.D. New York) (transferred from E.D. Texas; 6:09-cv-00326-LED)	Case Terminated 11/9/2012; Opinion of the Court of Appeals for the Federal Circuit received 01/27/2014
4	<i>Realtime Data LLC d/b/a IXO v. CME Group Inc., et al.</i> , No. 1:11-cv-06697-RJH (S.D. New York) (transferred from E.D. Texas; No. 6:09-cv-00327-LED)	Case Terminated 11/9/2012; Opinion of the Court of Appeals for the Federal Circuit received 01/27/2014
5	<i>Chicago Board Options Exchange, Inc., v. Realtime Data LLC d/b/a IXO</i> , No. 09-cv-4486 (N.D. Ill.)	Dismissed
6	<i>Thomson Reuters Corporation v. Realtime Data, LLC d/b/a IXO</i> , No. 1:09-cv-07868-RMB (S.D.N.Y)	Consolidated with Case No. 2
7	<i>Realtime Data, LLC d/b/a IXO v. CME Group Inc., et al. (II)</i> , No. 6:10-cv-246 (E.D. Texas)	Consolidated with Case No. 4
8	<i>Realtime Data LLC d/b/a IXO v. Thomson Reuters Corporation et al. (II)</i> , No. 6:10-cv-247 (E.D. Texas)	Consolidated with Case No. 2
9	<i>Realtime Data, LLC d/b/a IXO v. Morgan Stanley, et al. (II)</i> , No. 6:10-cv-248 (E.D. Texas)	Consolidated with Case No. 3
10	<i>Realtime Data, LLC d/b/a IXO v. MetroPCS Texas, LLC et al.</i> , No. 6:10-cv-00493 (E.D. Texas)	Appeal Terminated
11	<i>Realtime Data, LLC d/b/a IXO v. Microsoft Corporation, et al.</i> , No. 4:14-cv-00827 (E.D. Texas)	Dismissed May 1, 2015
12	<i>Realtime Data, LLC d/b/a IXO v. Actian Corporation, et al.</i> , No. 6:15-cv-00463 (E.D. Texas)	Amended Complaints for Patent Infringement filed September 14, 2015
13	<i>Realtime Data, LLC d/b/a IXO v. Dropbox, Inc.</i> , No. 6:15-cv-00465 (E.D. Texas)	Transferred to the Northern District of California, January 16, 2016; Answer to Amended Complaint filed February 4, 2016
14	<i>Realtime Data, LLC d/b/a IXO v. Echostar Corporation, et al.</i> , No. 6:15-cv-00466 (E.D. Texas)	Consolidated with Case No. 12; Answer to Amended Complaint filed February 4, 2016

15	<i>Realtime Data, LLC d/b/a IXO v. Riverbed Technology, Inc., et al.</i> , No. 6:15-cv-00468 (E.D. Texas)	Consolidated with Case No. 12; Second Amended Complaint for Infringement filed February 2, 2016
16	<i>Realtime Data, LLC d/b/a IXO v. BMC Software, Inc.</i> , No. 6:15-cv-00464 (E.D. Texas)	Terminated October 5, 2015
17	<i>Realtime Data, LLC d/b/a IXO v. Oracle America, Inc., et al.</i> , No. 6:15-cv-00467 (E.D. Texas)	Consolidated with Case No. 12
18	<i>Realtime Data, LLC d/b/a IXO v. SAP America, Inc., et al.</i> , No. 6:15-cv-00469 (E.D. Texas)	Consolidated with Case No. 12; Answers to Amended Complaint filed February 4, 2016
19	<i>Realtime Data, LLC d/b/a IXO v. Teradata Corporation, et al.</i> , No. 5:16-cv-01836 (N.D. Cal.) (formerly no. 6:15-cv-00470 (E.D. Texas))	Transferred to the Northern District of California, January 19, 2016
20	<i>Realtime Data, LLC d/b/a IXO v. Apple Inc.</i> , No. 6:15-cv-00885 (E.D. Texas)	Order Granting Motion to Stay entered February 11, 2016
21	<i>Realtime Data LLC d/b/a IXO v. Hewlett Packard Enterprise Co., et al.</i> , No. 6:16-cv-00086 (E.D. Texas)	Complaint filed February 26, 2016
22	<i>Realtime Data LLC d/b/a IXO v. Oracle America, Inc.</i> , No. 6:16-cv-00088 (E.D. Texas)	Complaint filed February 26, 2016
23	<i>Realtime Data LLC d/b/a IXO v. CenturyLink, Inc., et al.</i> , No. 6:16-cv-00087 (E.D. Texas)	Complaint filed February 26, 2016
24	<i>Realtime Data LLC d/b/a IXO v. Dell, Inc., et al.</i> , No. 6:16-cv-00089 (E.D. Texas)	Complaint filed February 26, 2016
25	<i>Realtime Data LLC d/b/a IXO v. Teradata Operations, Inc.</i> , No. 2:16-cv-02743 (C.D. Cal.)	Complaint filed April 21, 2016

An updated court docket for a pending litigation is submitted herewith as document **NPL20**.

Information Disclosure Statement

Listed on accompanying IDS Forms PTO/SB/08a equivalent and PTO/SB/08b equivalent are documents that may be considered material to the patentability of this application as defined in

Atty. Dkt. No. 3421.005000C

37 C.F.R. §1.56, and in compliance with the duty of disclosure requirements of 37 C.F.R. §§ 1.97 and 1.98.

Applicant has listed publication dates on the attached IDS Forms based on information presently available to the undersigned. However, the listed publication dates should not be construed as an admission that the information was actually published on the date indicated.

Applicant reserves the right to establish the patentability of the claimed invention over any of the information provided herewith, and/or to prove that this information may not be prior art, and/or to prove that this information may not be enabling for the teachings purportedly offered.

This statement should not be construed as a representation that a search has been made, or that information more material to the examination of the present patent application does not exist. The Examiner is specifically requested not to rely solely on the material submitted herewith.

Filing under 37 C.F.R. § 1.97(b). This Information Disclosure Statement is being filed before the mailing of a first Office Action after the filing of a request for continued examination under 37 C.F.R. § 1.114. No statement or fee is required.

Copies of documents **FP1-FP2** and **NPL1-NPL20** are submitted. However, in accordance with 37 C.F.R. § 1.98(a)(2)(ii), no copies of the U.S. patents and patent application publications cited as documents **US1-US4** on the attached IDS Forms are submitted.

Applicant submits herewith Office Actions from the co-pending U.S. Patent Application Nos.:

Document **NPL6** is a copy of a Notice of Allowance mailed April 26, 2016, in the prosecution of co-pending, commonly-assigned U.S. Patent Application No. 14/727,309.

Document **NPL7** is a copy of a Notice of Allowance mailed May 6, 2016, in the prosecution of co-pending, commonly-assigned U.S. Patent Application No. 14/733,565.

The identification of these Office Actions is not to be construed as a waiver of secrecy as to those applications now or upon issuance of the present application as a patent. The Examiner is respectfully requested to consider the cited applications and the art cited therein during examination.

It is expected that the examiner will review the prosecution and cited art in the parent application nos. 14/733,565, filed June 8, 2015 (now pending); 14/577,286, filed December 19, 2014 (now abandoned); 14/134,933, filed December 19, 2013 (now U.S. Patent No. 8,929,442); 14/033,245, filed September 20, 2013 (now U.S. Patent No. 8,934,535); 13/154,239, filed June 6, 2011 (now U.S. Patent No. 8,553,759); 12/123,081, filed May 19, 2008 (now U.S. Patent No. 8,073,047); and 10/076,013, filed February 13, 2002 (now U.S. Patent No. 7,386,046), in accordance with MPEP 2001.06(b), and indicate in the next communication from the office that the art cited in the earlier prosecution history has been reviewed in connection with the present application.

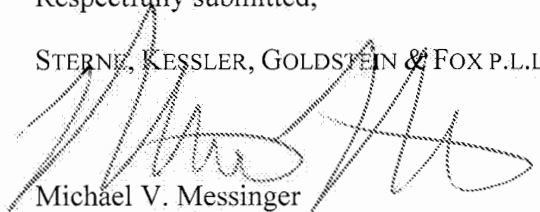
It is respectfully requested that the Examiner initial and return a copy of the enclosed IDS Forms, and indicate in the official file wrapper of this patent application that the documents have been considered.



The U.S. Patent and Trademark Office is hereby authorized to charge any fee deficiency, or credit any overpayment, to our Deposit Account No. 19-0036.

Respectfully submitted,

STERNE, KESSLER, GOLDSTEIN & FOX P.L.L.C.



Michael V. Messinger  
Attorney for Applicant  
Registration No. 37,575

Date: May 16, 2016

1100 New York Avenue, N.W.  
Washington, D.C. 20005-3934  
(202) 371-2600

2810062\_1.DOCX



Substitute for form 1449/PTO		<b>Complete if Known</b>	
<b>SIXTH SUPPLEMENTAL INFORMATION DISCLOSURE STATEMENT BY APPLICANT</b> <i>(Use as many sheets as necessary)</i>		Application Number	14/876,276
		Filing Date	October 6, 2015
		First Named Inventor	James J. FALLON
		Art Unit	2634
		Examiner Name	BOCURE, TESFALDET
		Attorney Docket Number	3421.005000C
Sheet	1	of	2

NON PATENT LITERATURE DOCUMENTS			
Examiner Initials*	Cite No. <sup>1</sup>	Include name of the author (in CAPITAL LETTERS), title of the article (when appropriate), title of the item (book, magazine, journal, serial, symposium, catalog, etc.), date, page(s), volume-issue number(s), publisher, city and/or country where published	T <sup>2</sup>
	NPL1	Joint Claim Construction and Prehearing Statement, filed in Realtime Data LLC d/b/a IXO v. Actian Corporation, et al., Case No. 6:15-cv-00463-RWS-JDL (E.D. Tex.), filed April 18, 2016; 26 pages.	
	NPL2	Complaint for Patent Infringement against Teradata Operations, Inc., filed in Realtime Data LLC d/b/a IXO v. Teradata Operations, Inc., Case No. 2:16-cv-02743 (C.D. Cal.), filed April 21, 2016; 31 pages.	
	NPL3	Defendant Oracle America, Inc.'s Answer to Realtime Data LLC's Complaint and Counterclaims, filed in Realtime Data LLC d/b/a IXO v. Oracle America, Inc., Case No. 6:16-cv-00088-RWS-JDL (E.D. Tex.), filed May 3, 2016; 22 pages.	
	NPL4	Defendants' Letter Requesting Permission to File a Motion for Partial Summary Judgment of Invalidity, filed in Realtime Data LLC d/b/a IXO v. Actian Corporation, et al., Case No. 6:15-cv-00463-RWS-JDL (E.D. Tex.) filed April 20, 2016; 6 pages.	
	NPL5	Plaintiff's Letter in Opposition to Moving Defendants' Letter Requesting Permission to File a Motion for Partial Summary Judgment, filed in Realtime Data LLC d/b/a IXO v. Actian Corporation, et al., Case No. 6:15-cv-00463-RWS-JDL (E.D. Tex.) filed May 9, 2016; 6 pages.	
	NPL6	Copy of Notice of Allowance for U.S. Pat. Appl. No. 14/727,309, mailed April 26, 2016; 7 pages.	
	NPL7	Copy of Notice of Allowance for U.S. Patent Appl. No. 14/733,565, mailed May 6, 2016; 6 pages.	
	NPL8	Petition for Inter Partes Review of U.S. Patent No. 7,415,530, filed in Dell Inc., et al. v. Realtime Data LLC d/b/a IXO, Case No. IPR2016-00878 (P.T.A.B.), filed April 22, 2016; 69 pages.	
	NPL9	Declaration of Charles D. Creusere, filed in Dell Inc., et al. v. Realtime Data LLC d/b/a IXO, Case No. IPR2016-00878 (P.T.A.B.), filed April 22, 2016; 124 pages.	
	NPL10	SOBH, et al., "A Comparison of Compressed and Uncompressed Transmission Modes," University of Pennsylvania Department of Computer and Information Science Technical Report No. MS-CIS-91-41, May 1991; 15 pages.	

Examiner Signature	Date Considered
-----------------------	--------------------

\*EXAMINER: Initial if reference considered, whether or not citation is in conformance with MPEP 609. Draw line through citation if not in conformance and not considered. Include copy of this form with next communication to applicant.

<sup>1</sup> Applicant's unique citation designation number (optional). <sup>2</sup> Applicant is to place a check mark here if English language Translation is attached.

Substitute for form 1449/PTO		<b>Complete if Known</b>	
<b>SIXTH SUPPLEMENTAL INFORMATION DISCLOSURE STATEMENT BY APPLICANT</b> <i>(Use as many sheets as necessary)</i>		Application Number	14/876,276
		Filing Date	October 6, 2015
		First Named Inventor	James J. FALLON
		Art Unit	2634
		Examiner Name	BOCURE, TESHALDET
		Attorney Docket Number	3421.005000C
Sheet	2	of	2

NON PATENT LITERATURE DOCUMENTS			
Examiner Initials*	Cite No. <sup>1</sup>	Include name of the author (in CAPITAL LETTERS), title of the article (when appropriate), title of the item (book, magazine, journal, serial, symposium, catalog, etc.), date, page(s), volume number, publisher, city and/or country where published	T <sup>2</sup>
	NPL11	9704 Data Compression Coprocessor Data Sheet, Stac Electronics, September, 1991; 56 pages.	
	NPL12	Petition for Inter Partes Review of U.S. Patent No. 8,643,513, filed in Riverbed Technology, Inc., et al. v. Realtime Data, LLC, Case No. IPR2016-00978 (P.T.A.B.), filed April 29, 2016; 65 pages.	
	NPL13	Declaration of Charles D. Creusere, Ph.D. Under 37 C.F.R. § 1.68, filed in Riverbed Technology, Inc., et al. v. Realtime Data, LLC, Case No. IPR2016-00978 (P.T.A.B.), filed April 29, 2016; 139 pages.	
	NPL14	Petition for Inter Partes Review of U.S. Patent No. 9,116,908, filed in Dell Inc. al. v. Realtime Data, LLC, Case No. IPR2016-01002 (P.T.A.B.), filed May 5, 2016; 68 pages.	
	NPL15	Declaration of Charles D. Creusere, Ph.D., filed in Dell Inc. al. v. Realtime Data, LLC, Case No. IPR2016-01002 (P.T.A.B.), filed May 5, 2016; 105 pages.	
	NPL16	Petition for Inter Partes Review of U.S. Patent No. 7,415,530, filed in Dell Inc. al. v. Realtime Data, LLC, Case No. IPR2016-00972 (P.T.A.B.), filed April 29, 2016; 69 pages.	
	NPL17	Declaration of Charles D. Creusere, Ph.D., filed in Dell Inc. al. v. Realtime Data, LLC, Case No. IPR2016-00972 (P.T.A.B.), filed April 29, 2016; 124 pages.	
	NPL18	Petition for Inter Partes Review of U.S. Patent No. 7,378,992, filed in Riverbed Technology, Inc. v. Realtime Data, LLC, Case No. IPR2016-00980 (P.T.A.B.), filed April 29, 2016; 57 pages.	
	NPL19	Declaration of Charles D. Creusere, Ph.D., filed in Dell Inc. al. v. Realtime Data, LLC, Case No. IPR2016-00980 (P.T.A.B.), filed April 29, 2016; 105 pages.	
	NPL20	Court Docket History for Realtime Data LLC d/b/a IXO v. Teradata Operations, Inc., Case No. 2:16-cv-02743 (C.D. Cal), downloaded April 26, 2016; 2 pages.	

2810041\_1.DOCX

Examiner Signature	Date Considered
-----------------------	--------------------

\*EXAMINER: Initial if reference considered, whether or not citation is in conformance with MPEP 609. Draw line through citation if not in conformance and not considered. Include copy of this form with next communication to applicant.

<sup>1</sup> Applicant's unique citation designation number (optional). <sup>2</sup> Applicant is to place a check mark here if English language Translation is attached.

## Electronic Patent Application Fee Transmittal

<b>Application Number:</b>	14876276			
<b>Filing Date:</b>	06-Oct-2015			
<b>Title of Invention:</b>	Video Data Compression Systems			
<b>First Named Inventor/Applicant Name:</b>	James J. FALLON			
<b>Filer:</b>	Michael V. Messinger/William Flanigen			
<b>Attorney Docket Number:</b>	3421.005000C			
Filed as Large Entity				
<b>Filing Fees for Utility under 35 USC 111(a)</b>				
<b>Description</b>	<b>Fee Code</b>	<b>Quantity</b>	<b>Amount</b>	<b>Sub-Total in USD(\$)</b>
<b>Basic Filing:</b>				
<b>Pages:</b>				
<b>Claims:</b>				
<b>Miscellaneous-Filing:</b>				
<b>Petition:</b>				
<b>Patent-Appeals-and-Interference:</b>				
<b>Post-Allowance-and-Post-Issuance:</b>				
<b>Extension-of-Time:</b>				

Description	Fee Code	Quantity	Amount	Sub-Total in USD(\$)
<b>Miscellaneous:</b>				
Request for Continued Examination	1801	1	1200	1200
<b>Total in USD (\$)</b>				<b>1200</b>

## Electronic Acknowledgement Receipt

<b>EFS ID:</b>	25786529
<b>Application Number:</b>	14876276
<b>International Application Number:</b>	
<b>Confirmation Number:</b>	3403
<b>Title of Invention:</b>	Video Data Compression Systems
<b>First Named Inventor/Applicant Name:</b>	James J. FALLON
<b>Customer Number:</b>	26111
<b>Filer:</b>	Michael V. Messinger/William Flanigen
<b>Filer Authorized By:</b>	Michael V. Messinger
<b>Attorney Docket Number:</b>	3421.005000C
<b>Receipt Date:</b>	16-MAY-2016
<b>Filing Date:</b>	06-OCT-2015
<b>Time Stamp:</b>	14:41:20
<b>Application Type:</b>	Utility under 35 USC 111(a)

### Payment information:

Submitted with Payment	yes
Payment Type	Credit Card
Payment was successfully received in RAM	\$1200
RAM confirmation Number	992
Deposit Account	
Authorized User	

The Director of the USPTO is hereby authorized to charge indicated fees and credit any overpayment as follows:

<b>File Listing:</b>					
<b>Document Number</b>	<b>Document Description</b>	<b>File Name</b>	<b>File Size(Bytes)/ Message Digest</b>	<b>Multi Part /.zip</b>	<b>Pages (if appl.)</b>
1	Foreign Reference	FP1_WO0046688.pdf	1674916 05f949ee977f215f4760b844b779e4a0444d5556	no	16
<b>Warnings:</b>					
<b>Information:</b>					
2	Foreign Reference	FP2_WO9739421.pdf	4120200 131adf98eae5bdd3ab06eccc8cfff4ae0ca90435	no	33
<b>Warnings:</b>					
<b>Information:</b>					
3	Non Patent Literature	NPL1_Actian_Joint_CC_04182016.pdf	243572 594759e2e8d141354c87d30586b305d82f817244	no	26
<b>Warnings:</b>					
<b>Information:</b>					
4	Non Patent Literature	NPL2_Oracle_Answer_05032016.pdf	182401 c7d0495b0c5e7202289499a273551ac0570bf9f9	no	22
<b>Warnings:</b>					
<b>Information:</b>					
5	Non Patent Literature	NPL3_Defendants_Letter_Summary_Judgment_04202016.pdf	142527 7ec4d06e20f5bd6560d330ee557e26226d643b9b	no	6
<b>Warnings:</b>					
<b>Information:</b>					
6	Non Patent Literature	NPL4_Realttime_Opposition_Defendants_Letter_Summary_Judgment_05092016.pdf	164551 0e7b6a2e87b2b8c156662b7ace888db3a90d75ef	no	6
<b>Warnings:</b>					
<b>Information:</b>					
7	Non Patent Literature	NPL5_Teradata_Operations_Complaint_04212016.pdf	306859 8f2dd01bc317afb3cfff896c54a79fe9499387c7	no	31
<b>Warnings:</b>					
<b>Information:</b>					



8	Non Patent Literature	NPL6_NOA_14727309_04262016.pdf	410266	no	7
			67b3774e4683895bd05fd4356cb75575f83558d3		
<b>Warnings:</b>					
<b>Information:</b>					
9	Non Patent Literature	NPL7_NOA_14733565_05062016.pdf	146217	no	6
			2cf6d27590c598e8e71f57f87b57c3f8accf9e16		
<b>Warnings:</b>					
<b>Information:</b>					
10	Non Patent Literature	NPL8_Petition_IPR201600878_04222016.pdf	571890	no	69
			fed97410f4430123b92737b8eb9299a7e6ae32e		
<b>Warnings:</b>					
<b>Information:</b>					
11	Non Patent Literature	NPL9_Creusere_Declaration.pdf	1157954	no	124
			1bbd0c1342b501d1734e13c7f465105c48f31678		
<b>Warnings:</b>					
<b>Information:</b>					
12	Non Patent Literature	NPL10_Sobh_1991.pdf	2676227	no	15
			89ff2fefe00cf103e2e63c93d9d01b05f2af2053		
<b>Warnings:</b>					
<b>Information:</b>					
13	Non Patent Literature	NPL11_STAC_Data_Compression_Coprocessor.pdf	10753123	no	56
			c7bf4a8f450ce91cd705f8f0a4929555d966a7		
<b>Warnings:</b>					
<b>Information:</b>					
14	Non Patent Literature	NPL12_IPR201600978_Petition.pdf	662626	no	65
			faf165924e19de09611a1703d25ddc30a9ae430c		
<b>Warnings:</b>					
<b>Information:</b>					
15	Non Patent Literature	NPL13_IPR201600978_Creusere_Declaration.pdf	1267875	no	139
			4e789c3dbd5ec22f091fb9b49d281222dfbd0bcd		
<b>Warnings:</b>					
<b>Information:</b>					
16	Non Patent Literature	NPL14_IPR201601002_Petition_05052016.pdf	686824	no	68
			c938ee4ee1dcfb4e84dfca796a1e380a3fd2b6		
<b>Warnings:</b>					
<b>Information:</b>					

17	Non Patent Literature	NPL15_IPR201601002_Creuser_e_Declaration.pdf	927635 0b9a3910606ba657ac7aa6091372b5af77f6a430	no	105
<b>Warnings:</b>					
<b>Information:</b>					
18	Non Patent Literature	NPL16_IPR201600972_Petition.pdf	557319 c9ccd727584b0d9ecccaca23d15ea921c0a82a6	no	69
<b>Warnings:</b>					
<b>Information:</b>					
19	Non Patent Literature	NPL17_IPR201500972_Creuser_e_Declaration.pdf	1177836 565c05307bab08cca3677c1065702b1d74a04239	no	124
<b>Warnings:</b>					
<b>Information:</b>					
20	Non Patent Literature	NPL18_IPR201600980_Petition.pdf	603008 ae57b3263342d3894a51c1ce892e7794c15ad1d	no	57
<b>Warnings:</b>					
<b>Information:</b>					
21	Non Patent Literature	NPL19_IPR201600980_Creuser_e_Declaration.pdf	931189 f208e6c0dda99dc8b9c8b964d794eb6c1970acaf	no	93
<b>Warnings:</b>					
<b>Information:</b>					
22	Non Patent Literature	NPL20_Teradata_Operations_Docket_04262016.pdf	99284 f9a417ff9b72eec11e3a2fe16b2c5ef8e75e97a4	no	2
<b>Warnings:</b>					
<b>Information:</b>					
23		3421005000C_6SIDS.pdf	1992223 96782c667a976885f21f763720b9640f564f3420	yes	14
	<b>Multipart Description/PDF files in .zip description</b>				
	<b>Document Description</b>		<b>Start</b>	<b>End</b>	
	Miscellaneous Incoming Letter		1	1	
	Request for Continued Examination (RCE)		2	2	
	Transmittal Letter		3	11	
	Information Disclosure Statement (IDS) Form (SB08)		12	14	
<b>Warnings:</b>					

<b>Information:</b>					
24	Fee Worksheet (SB06)	fee-info.pdf	30386	no	2
			9718a7fad8dcd917f18f447e111232eea27fba56		
<b>Warnings:</b>					
<b>Information:</b>					
<b>Total Files Size (in bytes):</b>				31486908	
<p><b>This Acknowledgement Receipt evidences receipt on the noted date by the USPTO of the indicated documents, characterized by the applicant, and including page counts, where applicable. It serves as evidence of receipt similar to a Post Card, as described in MPEP 503.</b></p> <p><b><u>New Applications Under 35 U.S.C. 111</u></b>  <b>If a new application is being filed and the application includes the necessary components for a filing date (see 37 CFR 1.53(b)-(d) and MPEP 506), a Filing Receipt (37 CFR 1.54) will be issued in due course and the date shown on this Acknowledgement Receipt will establish the filing date of the application.</b></p> <p><b><u>National Stage of an International Application under 35 U.S.C. 371</u></b>  <b>If a timely submission to enter the national stage of an international application is compliant with the conditions of 35 U.S.C. 371 and other applicable requirements a Form PCT/DO/EO/903 indicating acceptance of the application as a national stage submission under 35 U.S.C. 371 will be issued in addition to the Filing Receipt, in due course.</b></p> <p><b><u>New International Application Filed with the USPTO as a Receiving Office</u></b>  <b>If a new international application is being filed and the international application includes the necessary components for an international filing date (see PCT Article 11 and MPEP 1810), a Notification of the International Application Number and of the International Filing Date (Form PCT/RO/105) will be issued in due course, subject to prescriptions concerning national security, and the date shown on this Acknowledgement Receipt will establish the international filing date of the application.</b></p>					

PCT

WORLD INTELLECTUAL PROPERTY ORGANIZATION  
International Bureau



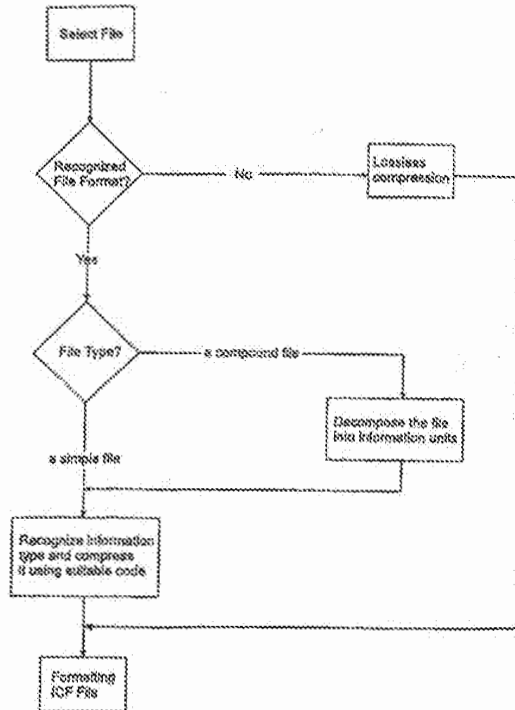
INTERNATIONAL APPLICATION PUBLISHED UNDER THE PATENT COOPERATION TREATY (PCT)

(51) International Patent Classification <sup>7</sup> : <b>G06F 17/00</b>	<b>A1</b>	(11) International Publication Number: <b>WO 00/46688</b>
		(43) International Publication Date: 10 August 2000 (10.08.00)
(21) International Application Number: PCT/CN00/00019	(81) Designated States: AU, CA, CN, JP, European patent (AT, BE, CH, CY, DE, DK, ES, FI, FR, GB, GR, IE, IT, LU, MC, NL, PT, SE);	
(22) International Filing Date: 2 February 2000 (02.02.00)	<b>Published</b> <i>With international search report.</i>	
(30) Priority Data: 09/241,472 2 February 1999 (02.02.99) US		
(71)(72) Applicant and Inventor: WANG, Jinbo [CN/CN]; Tuan Jie Hu Dong Li, Beijing 100026 (CN).		
(74) Agent: CHINA PATENT AGENT (H.K.) LTD.; Great Eagle Centre, 22/F, 23 Harbour Road, Wanchai, Hong Kong (CN).		

(54) Title: INTELLIGENT METHOD FOR COMPUTER FILE COMPRESSION

(57) Abstract

The present invention relates to an easy-to-use intelligent method for compressing computer files. In this method, a computer file containing different information types, such as text, image and sound, is automatically compressed by a computer, using suitable lossy or lossless codes. Both appropriate compression ratio and compression quality can be obtained. The present invention also relates to a method for decompressing a compressed file.



**FOR THE PURPOSES OF INFORMATION ONLY**

Codes used to identify States party to the PCT on the front pages of pamphlets publishing international applications under the PCT.

AL	Albania	EE	Spain	LS	Lesotho	SI	Slovenia
AM	Armenia	FI	Finland	LT	Lithuania	SK	Slovakia
AT	Austria	FR	France	LU	Luxembourg	SN	Senegal
AU	Australia	GA	Gabon	LV	Latvia	SZ	Switzerland
AZ	Azerbaijan	GB	United Kingdom	MC	Monaco	TD	Chad
BA	Bosnia and Herzegovina	GE	Georgia	MD	Republic of Moldova	TG	Togo
BB	Barbados	GH	Ghana	MG	Madagascar	TJ	Tajikistan
BE	Belgium	GN	Guinea	MK	The former Yugoslav Republic of Macedonia	TM	Turkmenistan
BF	Burkina Faso	GR	Greece	ML	Mali	TR	Turkey
BG	Bulgaria	HU	Hungary	MN	Mongolia	TT	Trinidad and Tobago
BJ	Benin	IE	Ireland	MR	Mauritania	UA	Ukraine
BR	Brazil	IL	Israel	MW	Malawi	UG	Uganda
BY	Belarus	IS	Iceland	MX	Mexico	US	United States of America
CA	Canada	IT	Italy	NE	Niger	UZ	Uzbekistan
CF	Central African Republic	JP	Japan	NL	Netherlands	VN	Viet Nam
CG	Congo	KE	Kenya	NO	Norway	YU	Yugoslavia
CH	Switzerland	KG	Kyrgyzstan	NZ	New Zealand	ZW	Zimbabwe
CI	Cote d'Ivoire	KP	Democratic People's Republic of Korea	PL	Poland		
CM	Cameroon	KR	Republic of Korea	PT	Portugal		
CN	China	KZ	Kazakhstan	RO	Romania		
CU	Cuba	LC	Saint Lucia	RU	Russian Federation		
CZ	Czech Republic	LI	Liechtenstein	SD	Sudan		
DE	Germany	LK	Sri Lanka	SE	Sweden		
DK	Denmark	LR	Liberia	SG	Singapore		
EE	Estonia						

INTELLIGENT METHOD FOR COMPUTER FILE COMPRESSION

## FIELD OF THE INVENTION

The present invention relates to a compression method and compression software for computer files. The present invention also relates to method and software for decompression of computer files that are compressed in accordance with the present invention.

## BACKGROUND OF THE INVENTION

Original information, such as text, image and sound, is usually not compressed when it is stored in the form of computer files. Because the size of such non-compressed files can be large, however, it is often necessary to compress the files, before transmitting them electronically over a wide area network, such as the Internet, or storing them in a portable memory device, such as a floppy disk.

There are currently two existing methods for computer file compression. In the first method, an information type of the file is first recognized by a user who wishes to compress the file, and depending on the type of the file, the user then runs one or more specific types of computer file compression software to compress the file. For example, the user may run commercially available compression software ARJ for compression of text files, LeadView for compression of image files and RealAudio for compression of audio files. Although this method allows to obtain required compression ratio, this process may be time-consuming and may require many different types of compression software. It will be readily appreciated that this method of operation can be particularly inefficient when the file to be compressed contains multiple information types, such as text, image and audio, or when the user wishes to compress a large number of files, particularly if they do not all have the same information type.

*CONFIRMATION COPY*

The second compression method is to compress a file using only a lossless code, such as LZW, regardless of what type of information is contained in the file. This is manifest in the adoption of the V.42 bis chip in modems to compress all of the information that passes the modem, or in the use of Winzip software to compress files of different types. While this method can save time spent by the user, it has the inherent weakness that this compression mode is not necessarily well suited for the type of information that is being compressed. As a result, the compression ratios provided by such operation method are generally poor. This method of operation is more suitable for compression of character information, but not suitable for other types of information, such as for image or sound.

#### SUMMARY OF THE INVENTION

The object of the present invention is to provide an intelligent compression method for computer file compression. This object is achieved in the present invention, in which different types of information, such as text, image and sound, in a compute file is automatically compressed by a computer, using suitable lossy or lossless codes. The method of the present invention is easy-to-use and provides both an appropriate compression ratio and compression quality.

In one embodiment, the method of the present invention automatically compresses a computer file using a computer and it comprises the following steps: (1) operating to recognize a format of the file by an extension name of the file and in conjunction with control information of the file; and (2) compressing the file in accordance with the format of the file as follows: (a) if the format of the file is not recognized, compressing the file with a lossless code; (b) if the format of the file is recognized and the file includes only a single type of data information, compressing data information of the file with a suitable lossy or lossless code in accordance with the type of data information contained in the file; and (c) if the format of the file is recognized and the file includes a plurality of types of data

information, first decomposing the file into a plurality of units each containing only a single type of data information, then compressing each unit with a suitable lossy or lossless code in accordance with the type of data information of the unit.

The method of the present invention may be used in any computer hardware and/or software system, such as in modem software or an e-mail system.

In accordance with another embodiment of the present invention, a method for automatically compressing a computer file using a computer is provided. The method comprises the following steps: (1) operating to recognize a format of the file by an extension name of the file and in conjunction with control information of the file; and (2) compressing the file in accordance with the format of the file as follows: (a) if the format of the file is recognized and the file contains only a single type of data information, compressing the data information contained in the file with a suitable lossy or lossless code in accordance with the type of data information contained in the file; (b) if the file format is not recognized or the file contains more than one type of data information type, compressing the file directly with lossless code.

#### BRIEF DESCRIPTION OF THE DRAWINGS

The present invention can be realized by computer software, computer hardware or a combination of computer hardware and software. This invention will be more apparent from the following description in conjunction with the appended drawings, in which:

Figure 1 illustrates, in a flow chart form, a method for compressing a computer file of the present invention; and

Figure 2 depicts, in a flow chart form, a method for decompressing a computer file of the present invention that has previously been compressed with the method of this invention.



## DETAILED DESCRIPTION OF THE INVENTION

The intelligent method for compressing computer files will now be described with reference to the figures, which illustrate, in a flowchart form, a preferred embodiment of the present invention.

Figure 1 depicts, in a flow chart form, a method of compressing a computer file of the present invention. The first action in accordance with Figure 1 is selecting a computer file which is to be compressed. This file selection is carried by the user who wish to compress a particular file. All of the other steps illustrated in Figure 1, except file selection, are automatically carried out by a computer system in accordance with the present invention. These steps are as follows:

A. The computer system operates to recognize the format of the file by the extension name of the file and in conjunction with the control information of the file to determine whether or not the file format is known.

B. If the file format is not known, then the system will automatically compress the file with a lossless code, such as LZW.

C. If the file format is known, the system then determine whether the file is a simple file (*i.e.*, it contains only a single data information type, such as text, Bitmap or Wave), or the file is a compound file (*i.e.*, it contains more than one type of data information).

D. If the file is a simple file, the system will then automatically recognize the type of data information contained in the file and automatically compress the data information using a suitable code. For example, a lossless code, such as LZW, may be used for compression of character information. A proper lossy code, such as JPEG or G.723, may be used for compression of image or audio information.

E. If the file is a compound file, such as RTF or HTML, and the system will automatically decompose the file into a plurality of units each containing only a single data information type, and then compressing each unit just as in the former case.

In accordance with the present invention, In order to decrease the complexity of the system, the system may also compress the compound file directly with a lossless code without the decomposition step and the followed steps. For reason of simplicity, this option is not depicted in Figure 1.

F. Although it is currently the case that the compressed image information has a standard file format, such as JPEG, but the other information compressed by codes such as LZW or G.723, do not have a standard file format. In order to contain the compressed data and control information, the compressed file format must be defined, which is defined herein as ICF ("Intelligent Compression Format"), with an extension name of icf. In the final step of Figure 1, a compressed file is formatted according to the ICF format.

It is important that it be possible to decompress a file that has been compressed according to the compression method of the present invention described above. A preferred embodiment of the decompression method is described with reference to Figure 2. The first step in Figure 2 is the ICF file selection, that means a user should select a file which must have an icf extension. In accordance with the present invention, the selected icf file is then subjected to the verification step, in which the control information of the file is automatically checked by a computer system to ascertain whether or not the format of the file is truly in the ICF format. All the followed actions are also automatically carried out by the computer system.

If the file is not a proper ICF file, then a termination step is executed. During execution of this step, the user is notified that the file is not in the proper format, and the method ceases.

If the file is determined to be in the ICF format by the verification step, the system will then further determine whether or not the file is a compressed simple file that contains only one type of compressed data information, or the file is a compressed compound file that contains more than one type of compressed data information.

If the ICF file is a compressed simple file, the system will automatically recognize the type of data information of the file, and decompressing the data information using corresponding suitable decode.

If the ICF file is a compressed compound file, such as the ICF file formed by compressing an RTF or HTML file, the system will automatically decomposes the ICF file into a plurality of compressed data information units each containing only a single type of compressed data information, and then decompressing each such unit just as in the above event.

If, in the compression stage, the compound file was compressed directly with a lossless code, in this decompression steps, the file will be decompressed using the corresponding a lossless decode. For reason of simplicity, this step is not illustrated in the Figure 2.

The final action in Figure 2 is to form a decompressed file and reconstruct its original file format.

It will be apparent to one skilled in the art that the method of the present invention can be readily adopted into various application systems, such as modem software and E-mail systems, to improve the speed of file transmission.

In accordance with the present invention, a new type of compression and decompression software has been provided. This software provides a simple-to-use and efficient way for computer file compression and decompression, with both an appropriate compression ratio and compression quality. This software has demonstrated that the

method of the present invention as described herein is advantageous over existing file compression methods.

Although the present invention has been described with reference to a preferred embodiment, it will also be appreciated by those of ordinary skill in the art that modifications can be made to the form of the invention without departing from its spirit and scope, which is defined in the following claims.

## WHAT IS CLAIMED IS:

1. Method for automatically compressing a computer file by a computer, comprising the following steps:
  - (1) operating to recognize a format of the file by an extension name of the file and in conjunction with control information of the file; and
  - (2) compressing the file in accordance with the format of the file as follows:
    - a. if the format of the file is not recognized, compressing the file with a lossless code;
    - b. if the format of the file is recognized and the file includes only a single type of data information, compressing data information of the file with a suitable lossy or lossless code in accordance with the type of data information contained in the file; and
    - c. if the format of the file is recognized and the file includes a plurality of types of data information, first decomposing the file into a plurality of data information units each containing only a single type of data information, then compressing each unit with a suitable lossy or lossless code in accordance with the type of the data information contained in the unit.
  
2. Method for automatically compressing a computer file by a computer, comprising the following steps:
  - (1) operating to recognize a format of the file by an extension name of the file and in conjunction with control information of the file; and
  - (2) compressing the file in accordance with the format of the file as follows:
    - a. if the format of the file is recognized and the file contains only a single type of data information, compressing the data information

contained in the file with a suitable lossy or lossless code in accordance with the type of data information contained in the file;

- b. if the file format is not recognized or the file contains more than one type of data information type, compressing the file directly with a lossless code.

- 3. Method for automatically compressing a computer file by a computer, comprising the following steps:
  - a. operating to recognize a format of the computer file on the basis of an extension name of the file and control information of the file; and
  - b. compressing the file in accordance with the format of the file.
- 4. The use of the method of claim 1 in computer software, computer hardware, or a combination of computer hardware and software.
- 5. The use of the method of claim 2 in computer software, computer hardware, or a combination of computer hardware and software.
- 6. The use of the method of claim 3 in computer software, computer hardware, or a combination of computer hardware and software.
- 7. The use of the method of claim 1 as a separate compression tool.
- 8. The use of the method of claim 2 as a separate compression tool.
- 9. The use of the method of claim 3 as a separate compression tool.

10. The use of the method of claim 1 in any application system.
11. The use of the method of claim 2 in any application system.
12. The use of the method of claim 3 in any application system.

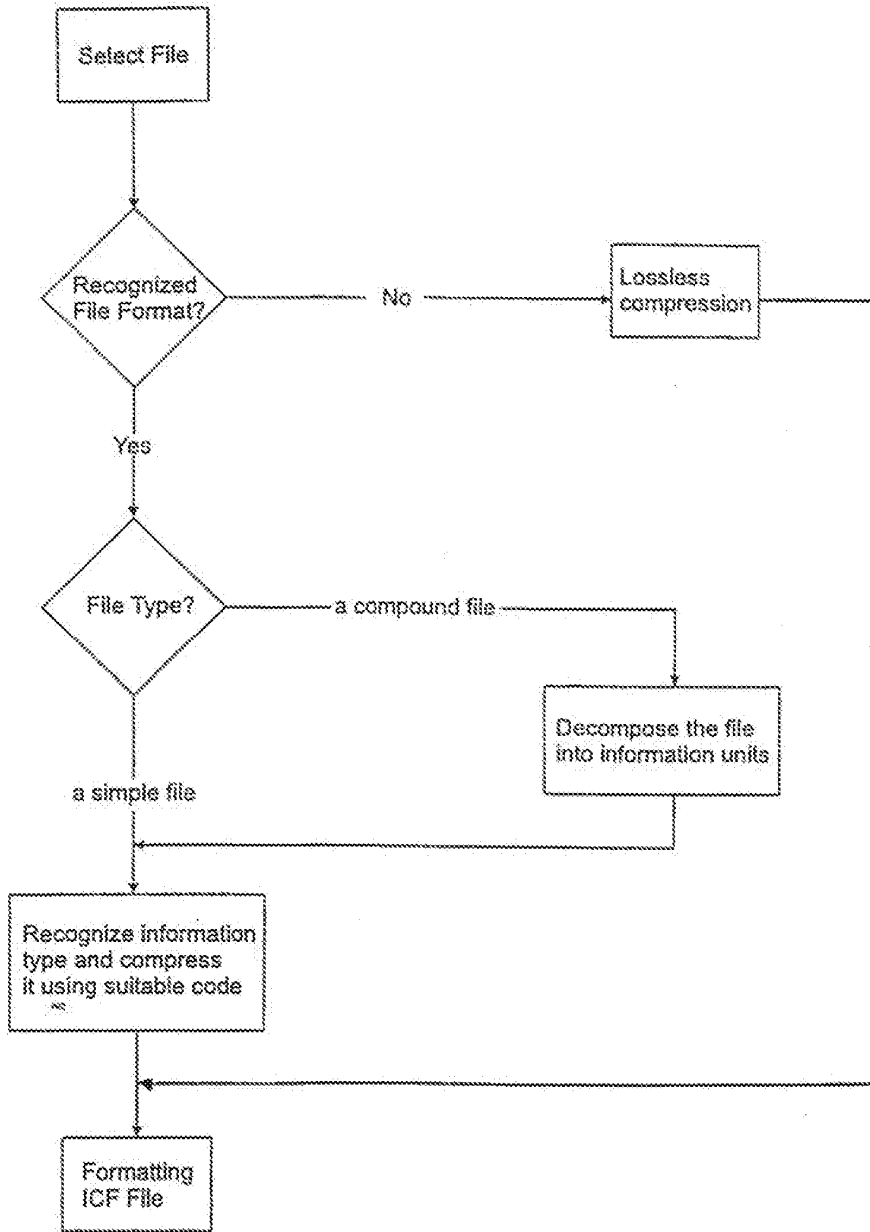


Figure 1



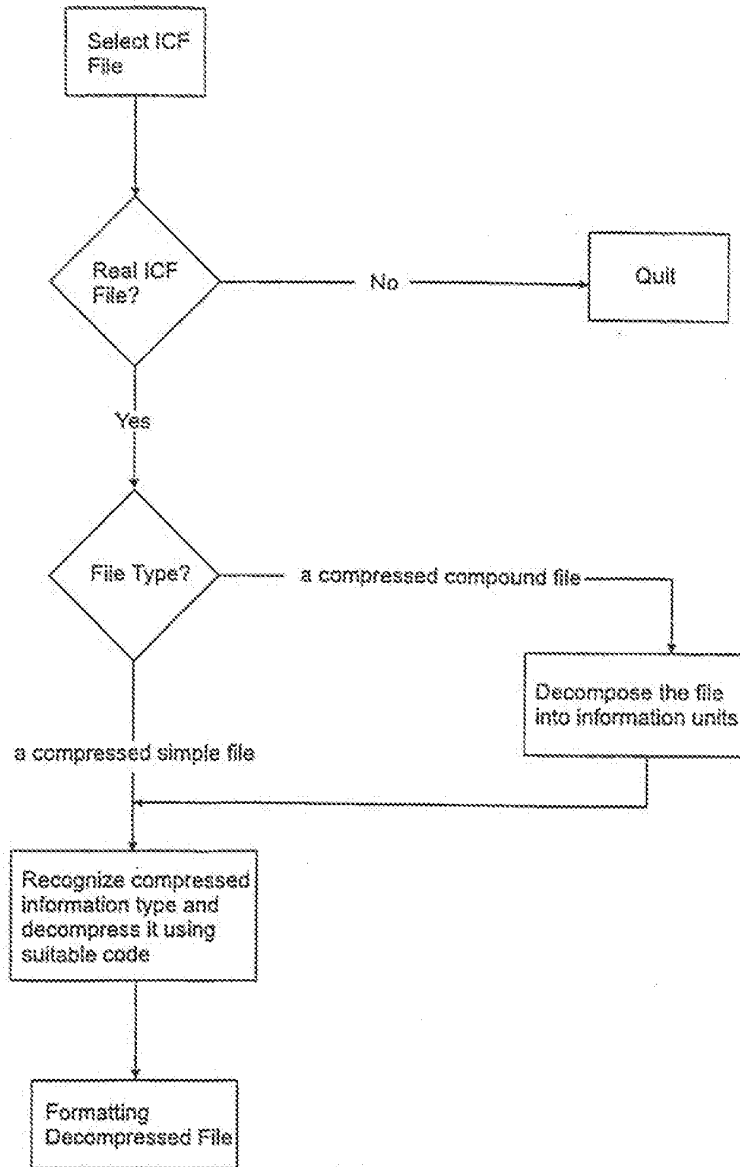
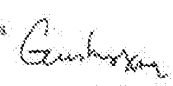


Figure 2

INTERNATIONAL SEARCH REPORT

International application No.

PCT/CN 09/00019

A. CLASSIFICATION OF SUBJECT MATTER		
G06F 17/00		
According to International Patent Classification (IPC) or to both national classification and IPC		
B. FIELDS SEARCHED		
Minimum documentation searched (classification system followed by classification symbols)		
G06P 17/00, 17/20, 17/21, 17/22, 17/28, 9/00, G06T 9/00, H01N 1/111, H05M 7/30		
Documentation searched other than minimum documentation to the extent that such documents are included in the fields searched		
Electronic data base consulted during the international search (name of data base and, where practicable, search terms used)		
C. DOCUMENTS CONSIDERED TO BE RELEVANT		
Category	Citation of document, with indication, where appropriate, of the relevant passages	Relevant to claim No.
A	EP0813167A2 the whole document	1-12
A	EP 0411232A2 the whole document	1-12
A	CN 1191355A the whole document	1-12
<input type="checkbox"/> Further documents are listed in the continuation of Box C. <input checked="" type="checkbox"/> See patent family annex.		
<p>* Special categories of cited documents:</p> <p>* A* document defining the general state of the art which is not considered to be of particular relevance</p> <p>* B* earlier application or patent but published on or after the international filing date</p> <p>* L* document which may throw doubts on priority claim(s) or which is cited to establish the publication date of another citation or other special reason (as specified)</p> <p>* O* document referring to an oral disclosure, use, exhibition or other means</p> <p>* P* document published prior to the international filing date but later than the priority date claimed</p> <p>* T* later document published after the international filing date or priority date and not in conflict with the application but cited to understand the principle or theory underlying the invention</p> <p>* X* document of particular relevance; the claimed invention cannot be considered novel or cannot be considered to involve an inventive step when the document is taken alone</p> <p>* Y* document of particular relevance; the claimed invention cannot be considered to involve an inventive step when the document is combined with one or more other such documents, such combination being obvious to a person skilled in the art</p> <p>* Z* document member of the same patent family</p>		
Date of the actual completion of the international search	Date of mailing of the international search report	
20 Apr. 2000 (20. 04. 00)	18 MAY 2000 (18. 05. 00)	
Name and mailing address of the ISA/CN	Authorized officer	
6 Xitucheng Rd. Jimen Bridge, Haidian District, 100088 Beijing, China	Guohong, Xie 	
Facsimile No. 86-10-62019151	Telephone No. 86-10-62093837	

Form PCT/ISA/210(second sheet)(July 1998)

INTERNATIONAL SEARCH REPORT  
 Information patent family members

International application No.  
 PCT/CN 00/00019

Patent document cited in search report	Publication date	Patent family member(s)	Publication date
EP 0613167A2	17.12.97	JP 10091140	19.01.98
EP 0111232A2	06.02.91	CA 2019133	01.02.91
		JP 2165181	17.07.91
		US 6204756	20.01.93
		B. 91221	30.03.93
		DE 68925281D	08.02.96
		ES 2081859T	16.03.96
		DE 68925281T	11.07.96
CN 1191355A	25.08.98	none	

Form PCT/ISA/210 (patent family annex) (July 1998)



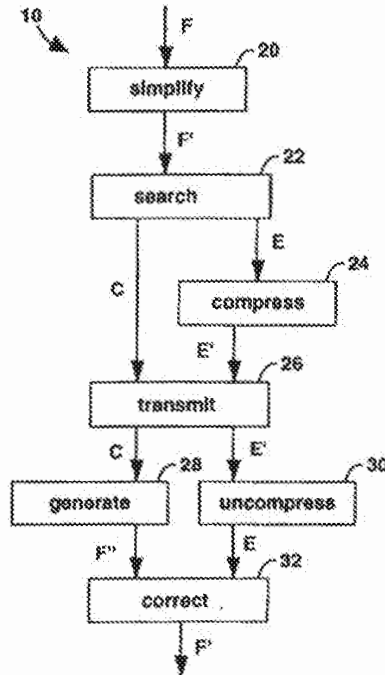
INTERNATIONAL APPLICATION PUBLISHED UNDER THE PATENT COOPERATION TREATY (PCT)

<p>(51) International Patent Classification <sup>6</sup> : <b>G06K 9/36, 9/46</b></p>	<p><b>AI</b></p>	<p>(11) International Publication Number: <b>WO 97/39421</b>                   (43) International Publication Date: 23 October 1997 (23.10.97)</p>
<p>(21) International Application Number: PCT/US97/05847                  (22) International Filing Date: 9 April 1997 (09.04.97)                   (30) Priority Data:                  08/633,386 16 April 1996 (16.04.96) US                   (71) Applicant: THE REGENTS OF THE UNIVERSITY OF CALIFORNIA [US/US]; 22nd floor, 300 Lakeside Drive, Oakland, CA 94612 (US).                   (72) Inventors: FEO, John, T.; 11321 Marwick Drive, Dublin, CA 94568 (US). HANKS, David, C.; 2675 Twin Creeks Drive, San Ramon, CA 94583 (US). KRAAY, Thomas, A.; 15192 Harrison Hill Lane, Leesburg, VA 22075 (US).                   (74) Agent: SARTORIO, Henry, P.; P.O. Box 508, L-703, Livermore, CA 94550 (US).</p>	<p>(81) Designated States: AU, CA, CN, JP, RU, European patent (AT, BE, CH, DE, DK, ES, FI, FR, GB, GR, IE, IT, LU, MC, NL, PT, SE).</p> <p><b>Published</b>  <i>With international search report.                  Before the expiration of the time limit for amending the claims and to be republished in the event of the receipt of amendments.</i></p>	

(54) Title: METHOD FOR DATA COMPRESSION BY ASSOCIATING COMPLEX NUMBERS WITH FILES OF DATA VALUES

(57) Abstract

A method (10) for compressing data for storage or transmission. Given a complex polynomial and a value assigned to each root, a root generated data file (RGDF) is created, one entry at a time. Each entry is mapped to a point in a complex plane. An iterative root finding technique is used to map the coordinates of the point to the coordinates of one of the roots of the polynomial. The value associated with that root is assigned to the entry. An equational data compression (EDC) method reverses this procedure. Given a target data file (F'), the EDC method uses a search algorithm (22) to calculate a set of m complex numbers and a value map that will generate the target data file. The error (E) between a simple target data file and generated data file is typically less than 10 %. Data files can be transmitted or stored without loss by transmitting (26) the m complex numbers, their associated values, and error file (E) whose size is at most one-tenth of the size of the input data file (F').



*FOR THE PURPOSES OF INFORMATION ONLY*

Codes used to identify States party to the PCT on the front pages of pamphlets publishing international applications under the PCT.

AL	Albania	ES	Spain	LS	Lesotho	SI	Slovenia
AM	Armenia	FI	Finland	LT	Lithuania	SK	Slovakia
AT	Austria	FR	France	LU	Luxembourg	SN	Senegal
AU	Australia	GA	Gabon	LV	Latvia	SS	Swaziland
AZ	Azerbaijan	GB	United Kingdom	MC	Monaco	TD	Chad
BA	Bosnia and Herzegovina	GE	Georgia	MD	Republic of Moldova	TG	Togo
BB	Barbados	GH	Ghana	MG	Madagascar	TJ	Tajikistan
BE	Belgium	GN	Guinea	MK	The former Yugoslav Republic of Macedonia	TM	Turkmenistan
BF	Burkina Faso	GR	Greece	ML	Mali	TR	Turkey
BG	Bulgaria	HU	Hungary	MN	Mongolia	TT	Trinidad and Tobago
BJ	Benin	IE	Ireland	MR	Mauritania	UA	Ukraine
BR	Brazil	IL	Israel	MW	Malawi	UG	Uganda
BY	Belarus	IS	Iceland	MX	Mexico	US	United States of America
CA	Canada	IT	Italy	NE	Niger	UZ	Uzbekistan
CF	Central African Republic	JP	Japan	NL	Netherlands	VN	Viet Nam
CG	Congo	KE	Kenya	NO	Norway	YU	Yugoslavia
CH	Switzerland	KG	Kyrgyzstan	NZ	New Zealand	ZW	Zimbabwe
CI	Côte d'Ivoire	KP	Democratic People's Republic of Korea	PL	Poland		
CM	Cameroon	KR	Republic of Korea	PT	Portugal		
CN	China	KZ	Kazakhstan	RO	Romania		
CU	Cuba	LC	Saint Lucia	RU	Russian Federation		
CZ	Czech Republic	LI	Liechtenstein	SD	Sudan		
DE	Germany	LK	Sri Lanka	SE	Sweden		
DK	Denmark	LR	Liberia	SG	Singapore		
EE	Estonia						

METHOD FOR DATA COMPRESSION BY ASSOCIATING  
COMPLEX NUMBERS WITH FILES OF DATA VALUES

The United States Government has rights in this invention pursuant to Contract No. W-7405-ENG-48 between the United States Department of Energy and the University of California for the operation of Lawrence Livermore National Laboratory.

BACKGROUND OF THE INVENTION

Field of the Invention

The present invention relates to data compression and more particularly to methods and systems for representing a computer data file as a set of complex number-value pairs.

Description of the Background Art

A so-called graphics interchange format (GIF) was developed by a telephone-based information source, CompuServe Incorporated. GIF uses Lempel-Ziv and Welch (LZW) compression as its primary source of image compression. The syntax of the GIF data stream provides the information required for the preparation of LZW decoding, such as color maps. GIF compression is lossless, with a compression ratio from 2:1 to 9:1 being possible, depending on the type of data being compressed.

LZW Encoding reduces the size of a data set in one dimension. The compression method developed by Lempel-Ziv and Welch, known as LZW compression, seeks to take advantage of repeated sequences of data values, even when the repetition exists non-contiguously. A unique code replaces a repeated sequence in the encoded data set, saving bytes each time that sequence is repeated.

-2-

Consider the following data stream and its corresponding compressed data stream.

original data set      5 23 7 12 5 23 7 6 12    5 23 7 6 12  
 5      compressed data set      Code1 12 Code1 Code2 Code1 Code2

Given the compressed data set, a table or "codebook" which assigns values to each code is used to decode the data. In the example above, such a codebook would assign "5 23 7" to the entry for Code1. If  
 10 the codebook is large, however, the overhead costs of storing it can greatly reduce the efficiency of compression. LZW compression was developed to avoid this storage requirement. It also has the pleasant characteristics of relatively low memory requirements, due to its sequential processing, and simplicity of algorithm, leading to  
 15 implementations which use a relatively small amount of computer code.

In LZW compression, an encoder and decoder build identical codebooks as the data stream is processed sequentially. The encoder outputs a pattern code only after it has found the pattern more than  
 20 once. The first time it processes a sequence of data, it places that sequence in its codebook and outputs the sequence without any encoding. During decoding, this sequence is output and an entry into the codebook is made for this sequence. The entry is assigned a code in the same manner that the encoder assigned a code, so that when this  
 25 code is encountered later, the decoder will output the correct sequence of values.

To further illustrate LZW compression, the following algorithms for encoding and decoding are presented, together with simulation examples for each. Here, a colon is used to indicate  
 30 concatenation. For example "abc" : "d" = "abcd".

-3-

```
encoding
initialize the codebook - one entry for each possible individual
value
prefix = empty string
5 repeat
    dataValue = next data value in data stream
    if prefix : dataValue is already in codebook
        then prefix = prefix : dataValue
    else {
10         add prefix : dataValue to the codebook
            output the prefix code from the codebook
            prefix = dataValue}
until all the data values are processed
15 output the code from the codebook for prefix
```

For the encoding algorithm, a string of data values is built until the string is different from any other previously coded string. New data strings are always made of some previously known strings (which has been entered into the codebook) plus one new data value. When a new pattern is found the new pattern is immediately added to the codebook, the code for the prefix of the new data string is output, and the data string is reinitialized to begin the search for a new data string. Each time a code is output, a new entry is made in the codebook.



5

10

15

20

25

simulation of encoding

assuming that original data can be one of three different values - a, b, or c. Consider the sample data stream "a b a b b b c".

Initialize the codebook as follows:

Code	Data Value	Prefix : Data Value
0	a	- : a
1	b	- : b
2	c	- : c

prefix = empty string

input dataValue	prefix: dataValue	new codebook entries code	new codebook entries data string	output	new prefix
a	- : a	[code 0 already entered]			0
b	0 : b	3	ab	0	1
a	1 : a	4	ba	1	0
b	0 : b	[code 3 already entered]			3
b	3 : b	5	abb	3	1
b	1 : b	6	bb	1	1
b	1 : b	[code 6 already entered]			6
c	6 : c	7	bbc	6	2

output last prefix value: 2

-5-

<u>decoding</u>	
	initialize the codebook - one entry for each possible individual value
	<b>code</b> = the first code value in the compressed data stream
5	output the data string that corresponds to <b>code</b> in the codebook
	repeat
	<b>oldCode</b> = <b>code</b>
	<b>code</b> = next code value from compressed data stream
	if <b>code</b> already exists in the codebook
10	then {
	output the data string corresponding to <b>code</b>
	<b>prefix</b> = <b>oldCode</b>
	<b>suffix</b> = first value from output data string )
	else {
15	<b>prefix</b> = <b>oldCode</b>
	<b>suffix</b> = first value from the <b>prefix</b> data string
	output <b>prefix</b> : <b>suffix</b> )
	add <b>prefix</b> : <b>suffix</b> to the codebook
20	until all code values are processed

For the if-statement, when the input code is already in the codebook, it is a straight forward process to output the string corresponding to that code. When a code is encountered which is not yet in the codebook, the immediately preceding data values must form the new data string. The new data string being formed is immediately preceded by itself. Since the preceding suffix starts the current prefix, the new code's data string must begin and end with the same data value. And since the pattern is repeated, the prefix of the new data string must be the string corresponding to the code previously input to the decoder. Therefore, the value of the undefined code is **oldCode** concatenated with the first value of **OldCode**.

simulation of decoding

The encoder produced the data stream "013162". This now becomes our input for the decoder.

5 Initialize the codebook as follows:

Code	Data Value	Prefix : Data Value
0	a	- : a
1	b	- : b
2	c	- : c

10

code = 0  
output a (data value of code 0)

		<u>new codebook entries</u>							
oldCode	input Code	in codebook?	prefix	suffix	output	code	string	suffix	
	0	1	yes	0	1	b	3	ab	0:1
	1	3	yes	1	0	ab	4	ba	1:0
	3	1	yes	3	1	b	5	abb	3:1
	1	6	no	1	1	bb	6	bb	1:1
	6	2	yes	6	2	c	7	bbc	6:2

15

20

The string produced by the decoder, "ababbbbc", is the original string which was input into the encoder.

25 The effectiveness of LZW compression is data dependent. Simple line drawings that are stored in raster format can be compressed as much as 16:1 or more. Raster scanned photographs are expected to achieve compression ratios from 2:1 to 9:1.

30 The Joint Photographic Experts Group (JPEG) has issued a suite of standards, with twenty nine distinct coding processes in all. The so-called JPEG compression standard was intended to satisfy a broad range of applications. Its seeks high compression ratios and high image fidelity. Applications can select from a broad range of compression ratios, trading off image quality for higher compression to meet the specific needs of an application. No restrictions are made on

35 the image contents, e.g., complexity or range of colors, or characteristics, such as resolution. A manageable computational complexity allows for reasonable software implementations and fast hardware

-7-

such as resolution. A manageable computational complexity allows for reasonable software implementations and fast hardware implementations. A lossless encoding mode provides for exact image reproduction. A sequential encoding mode provides for image reproduction using multiple passes through the data, where the image is initially blurry and each pass through the data adds further clarity to the image. And a hierarchical encoding mode is provided for image reproduction using a sequence of frames, each at different resolutions.

Other prior art data compression methods exist and some are in wide use. However, all leave the user wanting higher levels of compression with lower losses occurring in such compression. No conventional compression method has thus far proven totally satisfactory, even in particular applications.

#### SUMMARY OF THE INVENTION

An object of the present invention is to provide a method for starting with a data file to compress and finding the roots of the polynomial, assuming such a polynomial exists, that will generate the same data file in a reconstruction either exactly or within some threshold of error.

Briefly, a method embodiment of the present invention compresses data for storage or transmission. For a data file of pixel values organized as an  $n \times n$  grid of pixels, the data file of pixel values, or any computer data file, may be compressed by the method of the present invention. Letting  $G$  be an  $n \times n$  grid superimposed on the complex plane, and  $P$ , an  $m$  degree polynomial. Letting  $A$  be a function of the first derivative of  $P$ , and letting  $B$  be a function of the second derivative of  $P$ . And further letting  $C(i)$  be a map to a unique color for each root of  $P$ , where  $1 \leq i \leq m$ .  $A$  and  $B$  are then iteratively solved for each  $z$  in  $G$ . The solution ultimately converges within some epsilon of one of the roots of  $P$ . When  $z$  converges to root  $i$ ,  $C(i)$  is assigned to  $z$ .  $P$ ,  $A$  and  $B$  can be defined for any  $m$  numbers in the complex plane and

-8-

color function C to generate a data file of pixel values encoded by m complex numbers.

An advantage of the present invention is that a method for compressing data is provided.

5 Another advantage of the present invention is that a method of compressing data with few losses and high compression ratios is provided.

#### BRIEF DESCRIPTION OF THE DRAWINGS

Fig. 1 is a flowchart of an equational data file compression method embodiment of the present invention for data compression;

10 Fig. 2 shows a more detailed flowchart of the method of Fig. 1;

Fig. 3 is a flowchart for a generic search method useful in the method of Fig. 2; and

15 Fig. 4 is a flowchart of a generating method useful in the method of Figs. 2 and 3.

#### DETAILED DESCRIPTION OF THE INVENTION

Figs. 1 illustrates an equational data compression (EDC) method embodiment of the present invention for compressing and decompressing data, and is referred to herein by the general reference numeral 10. The EDC method 10 comprises a compression step 12, a transmission step 14, and a decompression step 16. The compression step 12 takes the data file F and returns a data file F'. The file F is a file of values whose type depends on the data medium. For example, if the file F is a text file, then the values might be octal numbers such that F(i) encodes the i-th character of the text. If the file F is a data file file, then the values might be eight-bit binary numbers such that F(i) encodes the color of the i-th pixel of the data file. The compression step 12 reduces the size of the data file to minimize the amount of data that needs to be transmitted or stored by the transmission step 14.

20

25

-9-

The transmission step 14 either transmits or stores the data file  $F$ . The transmission or storage of data is assumed here to be without error. Any of a number of conventional methods may be used to detect and/or correct errors due to faulty transmission or storage.

5 The decompression step 16 inputs the data file  $F'$  and outputs the data file  $F''$ . It uses an inverse method to that used by the compression step 12 to uncompress the data. Where file  $F''$  equals file  $F$ , then the compression method was lossless. Otherwise, the compression resulted in data loss. The extent to which the  
10 compression method is lossy depends on the methods used steps 12 and 16.

Fig. 2 illustrates the EDC method 10 in greater detail. A simplify step 20, a search step 22, and a compress step 24 are equivalent to the compression step 12 of Fig. 1. A transmission step 26 is  
15 equivalent to the transmission step 14 of Fig. 1. A generating step 28, a decompression step 30, and a correction step 32 are equivalent to the decompression step 16 in Fig. 1. The simplify step 20 takes the data file  $F$  and returns a simplified data file  $F'$ . This step may or may not be empty. The form of the simplification is data dependent and the  
20 degree of simplification depends on the amount of loss information tolerable by the sender and receiver. For example, this step might reduce the number of colors in a data file file from a maximum of 256 to twenty six by dividing each value in the file  $F$  by 10. The search step 22 takes the data file  $F'$  and returns two outputs,  $C$  and  $E$ . Output  $C$  is a  
25 set of tuples  $\{z, v\}$ , such that  $z$  is complex number, and  $v$  is a value in  $F'$ . The search step 22 uses a search heuristic to find  $C$  such that  $G(C, i) = F'(i)$ . Since it is unlikely that the search heuristic will return a set of numbers that regenerates  $F'$  without loss, the step returns an error file  $E$ . The tuple  $(i, y)$  is in  $E$  if and only if  $G(C, i) \neq F'(i)$  and  $F'(i) = y$ . A  
30 conventional genetic algorithm is used to find  $C$ , however, practically any search algorithm can be used. The compression step 24 compresses

-10-

the file E, e.g., using any conventional lossless compression algorithm. Its output is the data file E'. The transmission step 26 either electronically transmits or stores C and E', e.g., across the Internet or into a hard disk file. Such transmission or storage of the data is  
5 assumed here to be without error. The generating step 28 implements the generation of an algorithm G, described in connection with Fig. 4. The generating step 28 inputs a set of complex numbers C and returns the data file P". The decompression step 30 uncompresses the data file E' to regenerate a data file E without loss. The correction step 32 inputs  
10 files F" and E, and returns a data file F'. For each tuple (i, y) in E, the box sets the value of F"(i) to y.

The search step 22 of Fig. 2 searches the complex plane for a set of tuples (z, v) such that a generate method can return a file F" as close as possible to F'. Any discrepancy between F" and F' is returned  
15 in E. The particular search algorithm used is not important. A genetic algorithm whose gross structure is shown in Fig. 3 has been used successfully. The particular mating, mutation, and replacement method used is beyond the scope of this description. Possible choices of methods are well documented in the literature.

Fig. 3 illustrates a generic search method 40. A step 42  
20 generates a population of possible solutions, e.g., it generates two or more possible values for C. Each value is referred to as an individual of the population. A step 44 mates the individuals of the population and thus generates a set of new individuals. As in nature, the method  
25 tends to preserve the best characteristics of the population and to eliminate the worse characteristics. Over the generations, the population includes fitter and fitter individuals, e.g., better and better solutions to the search problem. Typically, the methods implemented  
30 by steps 50 and 52 of Fig. 3 are used to evaluate the fitness of individuals. A step 46 mutates selected individuals. Mutations or random changes to the data are necessary to prevent the method from

-11-

becoming stuck at a local maximum. A step 48 replaces individuals from the previous generation with those born and mutated by steps 44 and 46, respectively. An output of step 48 is the next population of individuals. A step 50 generates a data file for each individual in P.

5 The set of data files is G. The step 50 is equivalent to step 28 of Fig. 2. A step 52 calculates the error between  $F'$  and each data file generated by step 50. A typical error function is the sum of  $\text{diff}(i)$ , where  $\text{diff}(i)$  is 1 if the two files have different values at position  $i$ , else 0. Step 52 returns the smallest error value computed ( $e$ ), the individual that generated  
10 the smallest error value ( $C$ ), and a file of the differences between that individual and  $F'$  ( $E$ ). A step 54 compares the error value with some threshold value. If the comparison is true, then the search terminates and  $C$  and  $E$  are returned; else, the new population and control are passed back to step 44.

15 The generation step 28 of Fig. 2 generates the file  $F''$  of  $n$  values,  $1 \leq i \leq n$ , from  $C$ . Letting  $P$  be a  $m$ -th degree complex polynomial whose roots  $r_j$ ,  $1 \leq j \leq m$ ,  $m$  complex numbers in  $C$ , and letting  $T$  be a function that transforms integers to complex numbers, then for each integer  $i$ ,  $1 \leq i \leq n$ , step 28 executes the data flow shown in  
20 Fig. 4. The inputs to the generating step 28 of Fig. 2 are assumed to be available to all the steps in Fig. 4 and so, do not explicitly show their edges.

Fig. 4 illustrates a generating method 60. A step 62 applies a transform function  $T$  to  $i$  and returns  $z$ . The appropriate transform  
25 function to use depends on the type of the data file. For example, if the data file is a 2-D data file of size  $n$  by  $n$ , then  $T(i)$  might return the complex number  $\{(i \text{ div } n)/n, (i \text{ mod } n)/n\}$ . A step 64 computes  $P(z)$ . If the computed value is less than some small value, then the step returns yes. Otherwise, the step 64 returns no. If the step 64 returns  
30 no, then control is passed to a step 66 that computes the displayed expression returning two complex values,  $a^+$  and  $a^-$ . A step 68 passes



-12-

the value with the smallest absolute value to a step 70 that decrements  
 z by this value. The decremented value and control back are passed  
 back to the step 64. If the step 64 returns yes, then control is passed to a  
 step 72 that searches C, and returns the value associated with the  
 5 complex number in C closest to z. The iterative computation of Fig. 4  
 terminates when z is within epsilon of some root of P.

An equational data compression (EDC) method of the present  
 invention reverses the creation data files that used an iterative root  
 finding method. Data files can be created using this method, and  
 10 equations which closely approximates a given data file can also be  
 found.

An iterative root finding method, developed by one of the  
 present inventors, Thomas Kraay, starts with a complex function, P,  
 with m complex roots and an arbitrary initial guess z, in the complex  
 15 plane, the iterative root finding method converges unexpectedly fast to  
 one of the function's roots, usually in two to four iterations. The  
 method has converged over ten million times to within  $10^{-6}$  of a root  
 value.

The iterative root finding method, e.g., illustrated in Fig. 4,  
 20 can be described mathematically, as follows:

Let P(z) be a known polynomial with unknown roots  $r_1, \dots, r_m$ . Then,

$$P(z) = \prod_{i=1}^m (z - r_i).$$

For  $z \in \{r_1, \dots, r_m\}$ , take the natural log of both sides to get,

25 
$$\ln P(z) = \ln \prod_{i=1}^m (z - r_i) = \sum_{i=1}^m \ln(z - r_i).$$

-13-

Taking the derivative of both sides,

$$\frac{d}{dz} \ln P(z) = \frac{d}{dz} \sum_{i=1}^m \ln(z - r_i) = \sum_{i=1}^m \frac{d}{dz} \ln(z - r_i) = \sum_{i=1}^m \frac{1}{(z - r_i)},$$

and since,

$$\frac{d}{dz} \ln P(z) = \frac{P'(z)}{P(z)},$$

5 then,

$$g(z) = \frac{P'(z)}{P(z)} = \sum_{i=1}^m \frac{1}{(z - r_i)}. \quad (\text{eq. 1})$$

Now taking the derivative of  $g(z)$  with respect to  $z$ , provides,

$$\frac{d}{dz} \frac{P'(z)}{P(z)} = \frac{d}{dz} \sum_{i=1}^m \frac{1}{(z - r_i)} = \sum_{i=1}^m \frac{-1}{(z - r_i)^2},$$

and since,

$$10 \quad -\frac{d}{dz} \frac{P'(z)}{P(z)} = \frac{[P'(z)]^2 - P(z)P''(z)}{P^2(z)},$$

then,

$$h(z) = \frac{[P'(z)]^2 - P(z)P''(z)}{P^2(z)} = \sum_{i=1}^m \frac{1}{(z - r_i)^2}. \quad (\text{eq. 2})$$

-14-

Given a complex number  $z$ , the values of  $g(z)$  and  $h(z)$  can be calculated. Let  $r_i$  represent some root of  $P(x)$ , and define the value  $a$  such that,

$$a = z - r_i \quad (\text{eq. 3})$$

5 The equations (1) and (2) can be rewritten,

$$g(z) = \frac{1}{a} + \sum_{\substack{i=1 \\ i \neq j}}^m \frac{1}{(z - r_i)} \quad \text{and} \quad (\text{eq. 1a})$$

$$h(z) = \frac{1}{a^2} + \sum_{\substack{i=1 \\ i \neq j}}^m \frac{1}{(z - r_i)^2} \quad (\text{eq. 2a})$$

There exists a complex number  $b$  such that,

$$\sum_{\substack{i=1 \\ i \neq j}}^m \frac{1}{(z - r_i)} = \frac{m-1}{b}$$

10 giving

$$g(z) = \frac{1}{a} + \frac{m-1}{b} \quad (\text{eq. 1b})$$

Let  $\epsilon$  be the complex number, such that,

$$\sum_{\substack{i=1 \\ i \neq j}}^m \frac{1}{(z - r_i)^2} = \frac{m-1}{b^2} + \epsilon \quad (\text{eq. 4})$$

-15-

For  $m > 2$ , discarding  $\epsilon$ , introduces error, but gives,

$$h(z) = \frac{1}{a^2} + \frac{m-1}{b^2} \quad (\text{eq. 2b})$$

There are two equations (1b) and (2b) in two unknowns (a and b). It can be shown that,

$$5 \quad a^{\pm} = \frac{m}{g(z) \mp \sqrt{(m-1)(mh(z) - g^2(z))}} \quad (\text{eq. 5})$$

Which is equivalent to the step 66. To aid in convergence, a is assigned the value of smaller magnitude,

$$a = \begin{cases} a^+ & \text{if } |a^+| < |a^-| \\ a^- & \text{otherwise} \end{cases} \quad (\text{eq. 6})$$

10 Which is equivalent to the step 68. By equation (3),  $r_1 = z - a$  is a root of the equation. However, having discarded  $\epsilon$  this equality no longer holds.  $z - a$  now only approximates  $r_1$ .

Given an initial guess  $z$ ,  $P(Z)$  is calculated. If the absolute value is greater than  $\epsilon$ , a is calculated letting  $z = z - a$ , e.g., step 70. Repeating this process, as in the step 64, until the absolute value of  $P(z)$  is less than  $\epsilon$ , a root of the polynomial is converged within  $\epsilon$ .

15 The iterative root finding method is used to generate data files. A file of size  $n$ ,  $0 \leq i \leq n-1$  is created, using the iterative root finding method. Let  $P(Z)$  be a polynomial with roots  $r_1, \dots, r_m$  and let  $v_1, \dots, v_m$  be a set of  $m$  values. Start by defining a transformation  
20 function from integers to points in the complex plane. Letting  $n = W * H$ , then  $T(i)$ ,  $0 \leq i \leq n-1$ , returns the complex number,

-16-

$$z = \left\{ \frac{i \operatorname{div} W}{H}, \frac{i \operatorname{mod} W}{W} \right\}.$$

Which is equivalent to the step 62.

Using  $z$  as an initial guess, the iterative method is used to calculate a root of  $P(z)$ . As in the step 72, if the  $i$ -th root is returned,  
 5 then the value  $v_i$  is assigned to the  $i$ -th datum in the file. The resulting file of values is referred to as a root generated data file (RGDF) and the procedure is called a generation process. For example, to create a data file data file of 40,000 pixels. Let  $W = 200$ ,  $H = 200$ ,  $r_1 = 0.0 + 0.0i$ ,  
 $v_1 = \text{blue}$ ,  $r_2 = 0.75 + 0.75i$ ,  $v_2 = \text{green}$ ,  $r_3 = 0.8 - 0.15i$ ,  $v_3 = \text{gray}$ ,  $r_4 = 1.5 -$   
 10  $0.50i$ , and  $v_4 = \text{purple}$ . Then, the RGDF created corresponds to a particular data file. Such file is uniquely encoded by the four root-value pairs used to create it.

The generation process can be reverse engineered. Since EDC is given a data file  $F$  of size  $n$ ,  $0 \leq i \leq n - 1$ , with  $m$  unique values, the  
 15  $m$  complex numbers can be found such that the RGDF returned by the generation process is equivalent to  $F$ . Although reversing the mathematical formulations might appear impossible, an attractive solution method is the use of general purpose search methods. The problem can be viewed as a search for  $m$  points in the complex plane,  
 20 where the optimality of a set of  $m$  points is defined by a fitness function. The current embodiments use a genetic algorithm to search for the  $m$  points, e.g., as in Fig. 3.

Genetic algorithms are search algorithms that depend on an imitation of nature and use the mechanics of natural selection and  
 25 natural genetics. The object is to improve a set of initial solutions, referred to as a "population" of individuals, using "recombination" and "mutation" of their "genetic material". The method combines survival of the fittest among solutions with a structured and randomized information exchange.

-17-

Each "generation" creates new solutions that replace old and ineffective solutions in the population. A solution's probability of recombination is directly proportional to its fitness. Only the most effective solutions survive. The selection of solutions for

5 recombination and mutation, as well as the replacement of solutions in the population are driven by genetic operators controlled by probability.

Genetic algorithms can work with several solutions at the same time, improving the solutions in each generation, while

10 simultaneously exploring new solutions in the search space. Genetic algorithms are also easily adapted to a variety of problems requiring adjustments to only the representation of solutions and the fitness function. Because the objective function used to measure fitness is the only information used to guide the search, no auxiliary or derivative

15 information is required.

A simple genetic algorithm (SGA) is described with the aid of the pseudo code of Table I. A solution consists of one, or occasionally more, bit-encoded strings, or chromosomes. Each bit's position is its

20 locus and the value of the bits as its allele (0 or 1 for binary strings). For simplicity, unless otherwise stated, we assume a single chromosome per individual and binary alleles.

TABLE I

25	randomly create and evaluate an initial population of size n
	for gen = 1 to MAX_GEN
	create a mating pool selecting individuals from the
	population using fitness proportionate selection
	form n/2 pairs from the mating pool and perform
	crossover and mutation
	replace current generation with offsprings
30	evaluate the fitness of the new population
	end for

-18-

output fittest individual as the solution

5 The first generation of a genetic algorithm consists of individuals whose chromosomes are randomly constructed, e.g., step 42. Assuming that genes may be one of two values, either 0 or 1, and letting  $P_1$  be the probability that a given gene will have the value 1. Each gene of each chromosome in the initial population can be assigned a value 1, with probability  $P_1$ , or a value of 0, with probability  $P_0 = 1 - P_1$ .

10 Once the procedure has defined all genes of a chromosome, it then applies the fitness function to determine the chromosome's fitness value. Once the procedure has created an initial population and determined the fitness of each individual, it then creates the next generation.

15 For successive generations, several mate selection, mating, and replacement are used. The process is continued for an indicated number of generations, or until some other terminating condition is encountered.

20 As the step 44 illustrates, mate selection selects  $n$  individuals to parent offspring in the next generation. The selected individuals create a mating pool. Such individuals are chosen according to their fitness values. On average, those with higher fitness values are selected more often than those with lower fitness values. More exactly, the probability that the algorithm selects individual  $I_j$  with fitness  $F_j$  is,

25 
$$P_i = \frac{F_i}{\sum_{j=1}^n F_j}$$

Such method, known as fitness proportionate reproduction (FPR) selection, is an artificial version of natural selection, a Darwinian "survival of the fittest" among individuals.

-19-

Table II represents a sample population of four individuals, their fitness values and selection probabilities, and the results of mate selection. In this example, the string is a binary number and the fitness function is  $f(x) = x^2$ .

5

TABLE II

INDIVIDUAL		FITNESS	SEL. PROB.	Mating Pool
i	ii	Fi	Pi	
1	10011	361	0.310	11001
2	00110	36	0.031	10011
3	01100	144	0.123	01100
4	11001	625	0.536	11011
Total		1166	1.000	

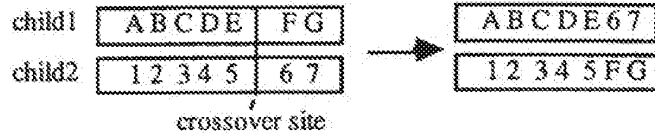
Once the mate selection is complete, the members of the mating pool are randomly divided into pairs for mating. Their chromosomes are manipulated by crossover and mutation with probability  $P_x$  and  $P_m$ , respectively.

10

During the crossover operation, a crossover site, a position between the individuals' genes, is selected at random. The alleles to the right of the crossover site are then swapped between the pair, as in Table III.



TABLE III



As in step 46, when  $P_x < 1.0$ , some pairs may not undergo the crossover operation, but all pairs are subject to mutation. The mutation operation considers each allele in every individual, and changes its value with probability  $P_m$ . When an allele is mutated, its value changes from 0 to 1 or 1 to 0. This operation allows the algorithm to recover genetic material which has been lost and to introduce new genetic material.

Table IV illustrates a full reproduction phase for  $P_x = 0.667$  and  $P_m = 0.033$ .

TABLE IV

i	Mating pairs	fitness	After crossover	After mutation	New generation	fitness
1	11001	625	11 100	11100	11100	784
2	01100	144	01 001	01001	01001	81
3	10011	361	100 11	10011	10111	529
4	11001	625	11001	11001	11001	625
Total		1755				2019

The step 48 includes a steady state genetic algorithm (SSGA) that is a variant of the SGA. In the SSGA, only a subset of individuals in a population, e.g., a "generation gap", are replaced in every

-21-

generation. The size of the generation gap,  $G$ , is usually expressed as a fraction of the overall population size. Thus, if  $n$  is the population size, the number of individual to be replaced each generation is  $G * n$ . A commonly chosen value for  $G$  is  $2/n$ . Only one pair is chosen to  
5 mate, and their offspring replace two individuals in the population. When  $G = 1.0$ , the algorithm replaces all individuals, as is equivalent to the SGA. With  $G < 1.0$ , a replacement rule is need to decide which individuals should perish to make room for the new offspring. Such  
10 individuals could be those with the lowest fitnesses. In inverse ranking, the individuals are ranked according to their fitnesses. Each individual is considered, starting with the least fit, and individuals are eliminated with probability greater than  $1/n$  until only two individuals remain.

SSGA thus imitates nature more accurately than the SGA,  
15 but has several drawbacks. Because low fitness individuals are quickly dismissed, the fitter individuals tend to dominate faster, leading to a greater possibility premature convergence. Also, the SSGA is not easily parallelizable, depending on the size of  $G$ . If  $G=2/n$ , there is no parallelism.

20 A variation of the SGA with linear fitness scaling has been used with success in embodiments of the present invention. The deviation from ordinary SGA involves the encoding of the problem and the manipulation of roots. Various methods have been attempted, e.g., in the initial population generation and root mutation.

25 The data file to compress is defined here as the target file. The target file is compressed and encoded with method embodiments of the present invention.

30 For encoding, an individual is comprised of a chromosome with  $N$  binary alleles, and  $N$  complex numbers and values, one for each locus in the chromosome. Table V represents an individual in this encoding.

-22-

TABLE V

allele 0	complex # 0	value 0
allele 1	complex # 1	value 1
allele 2	complex # 2	value 2
...	...	
allele N-1	complex # N-1	value N-1

5 A complex number is active if its corresponding allele in the chromosome is one. The roots of the polynomial associated with the individual are the active complex numbers. Thus, the degree of this polynomial is exactly the number of ones in the chromosome.

Table VI represents a polynomial associated with a sample individual.

10

TABLE VI

0	$5.0 + 3.2i$	blue
1	$3.3 - 1.6i$	red
1	$-2.4 + 10.0i$	grey
0	$4.1 - 5.9i$	purple
1	$-0.1 - 1.7i$	green

$$P(z) = [z - (3.3 - 1.6i)] [z - (-2.4 + 10.0i)] [z - (-0.1 - 1.7i)]$$

15 For the initial population, the value of each allele in each chromosome in the initial population is randomly chosen 0 or 1, with

-23-

equal probability. The complex numbers corresponding to each locus are chosen by creating a vector of random angle and random length (less than some value, L), transforming it to the form  $x+iy$ , and adding it to C, a complex number in the middle of the frame in the complex plane into which pixel locations are translated. Each locus of each chromosome in the population is assigned its own randomly generated root. Values are assigned randomly with equal probability.

For successive generations, mate selection, crossover, and mutation are conventional, except for a few points. No replacement policy is needed since as we use the SGA model. The triplet of allele, root, and color always stay together. Thus, when a crossover occurs, the roots and colors corresponding to each moved allele are also moved. The changing of the value of a root is also different. Like mutation of alleles, each root is considered for adjustment every generation. Adjustment occurs with small probability. When a root is adjusted, it is moved a random distance, e.g., less than some variable length, in the direction of a random angle.

The fitness measurement depends on how many values in the generated file match the corresponding value in the target file. The maximum fitness is n. The fittest file, e.g., file C in Fig. 2, to emerge from the genetic algorithm, referred to as the generated file, is most likely not equivalent to the target file. A greedy algorithm is applied to improve the solution and record the error entries in an error file, e.g., file E in Fig. 2.

For data file improvement, once the genetic algorithm converges, the generated file is improved using a greedy algorithm, that systematically adjusts each active root in the following way. An imaginary circle is placed around the root with a random radius. Fitnesses are sampled around the circle to determine the angle we should move the root to maximize fitness. A line is then drawn at this angle, and fitnesses sampled in order to determine the best distance to

-24-

move the root in this direction. The process is typically repeated until further attempts result in little or no improvement in fitness.

5 Although particular embodiments of the present invention have been described and illustrated, such is not intended to limit the invention. Modifications and changes will no doubt become apparent to those skilled in the art, and it is intended that the invention only be limited by the scope of the appended claims.

THE INVENTION CLAIMED IS

1. A method for compressing and uncompressing data for storage or transmission, wherein a data file is stored as a file of size  $N$ , and letting  $T$  be a function that maps integers to points in the complex plane  $P$ , which is an  $m$  degree polynomial, and letting  $A$  be a function of the first derivative of  $P$ , and  $B$  be a function of the second derivative of  $P$ , and further letting  $C(i)$  be a map to a unique value for each root of  $P$ , where  $1 \leq i \leq m$ , then  $A$  and  $B$  are then iteratively solved for each  $z = T(i)$ ,  $1 \leq i \leq N$ , and a solution ultimately converges within some epsilon of one of the roots of  $P$ , for when  $z$  converges to root  $j$ ,  $C(j)$  is assigned to  $z$ , and  $P$ ,  $A$  and  $B$  can be defined for any  $m$  numbers in the complex plane and color function  $C$  to generate a data file of pixel values encoded by  $m$  complex numbers.

2. The method of claim 1, wherein given a data file of size  $N$ , the  $m$  complex numbers and value function  $C$  are found that encode said data file using an optimization method including conventional genetic algorithms, wherein for a given target data file to compress, a main process is repeated until a solution sufficiently close to the target is found or some arbitrary maximum number of generations is exceeded, wherein said main process comprises producing a data file for each member of the generation, then evaluating each member's fitness against the target, then scaling the fitness values, then creating  $N/2$  couples of polynomials, where each couple is comprised of two polynomials randomly selected from the current generation, and where the probability of a member being assigned to a couple is in

-26-

direct proportion to its scaled fitness value, and then, mating each couple to generate two children, allowing for characteristics of each parent to contribute to each child or crossover and allowing for mutation.

15 3. A method for compressing data for storage or transmission, wherein given a complex polynomial and a value assigned to each root, a root generated data file (RGDF) is created, one entry at a time, and each entry is mapped to a point in a complex plane, then an  
5 iterative root finding technique is used to map the coordinates of the point to the coordinates of one of the roots of the polynomial, then the value associated with that root is assigned to the entry, whereafter an equational data compression (EDC) method is used to reverse such steps, wherein given a target data file, the EDC method uses a search  
10 algorithm to calculate a set of  $m$  complex numbers and a value map that will generate the target data file, wherein data files are transmitted or stored by transmitting the  $m$  complex numbers, their associated values, and an error file.

**Fig. 1**

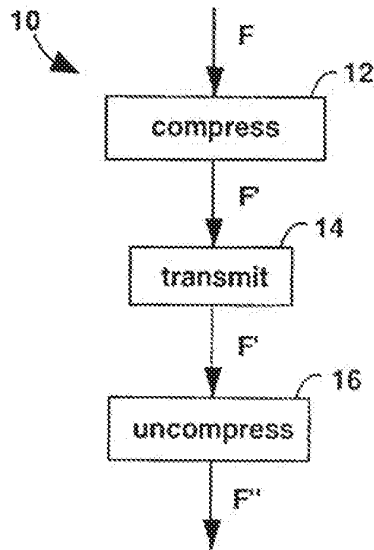




Fig. 2

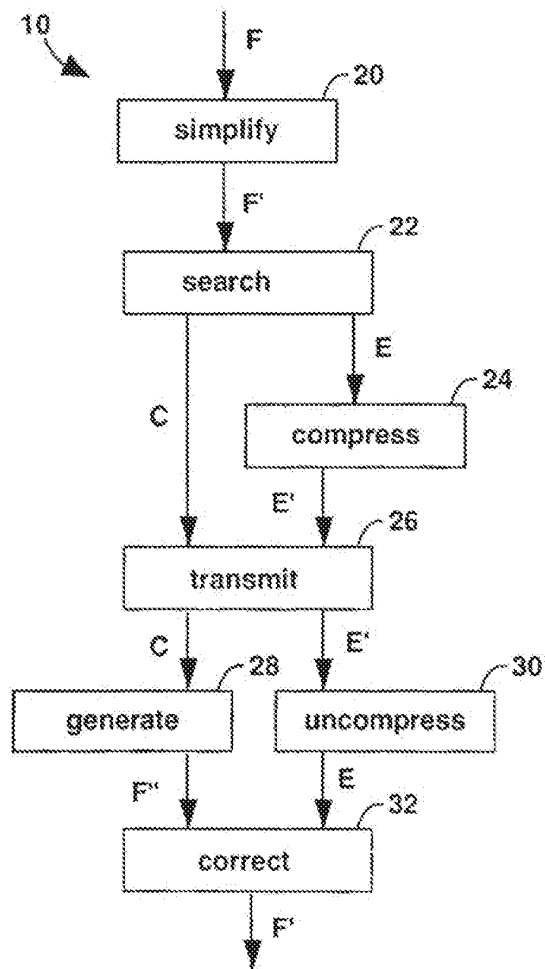


Fig. 3

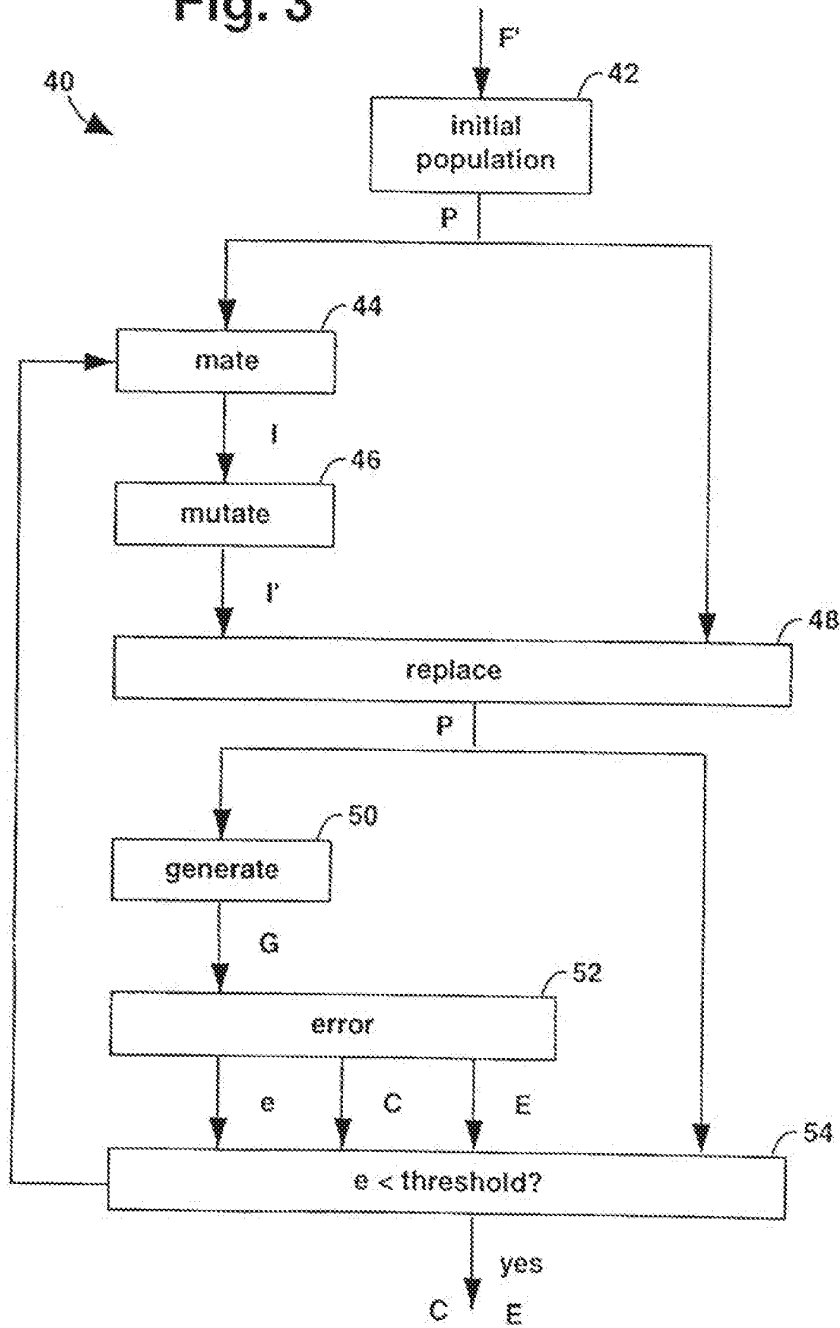
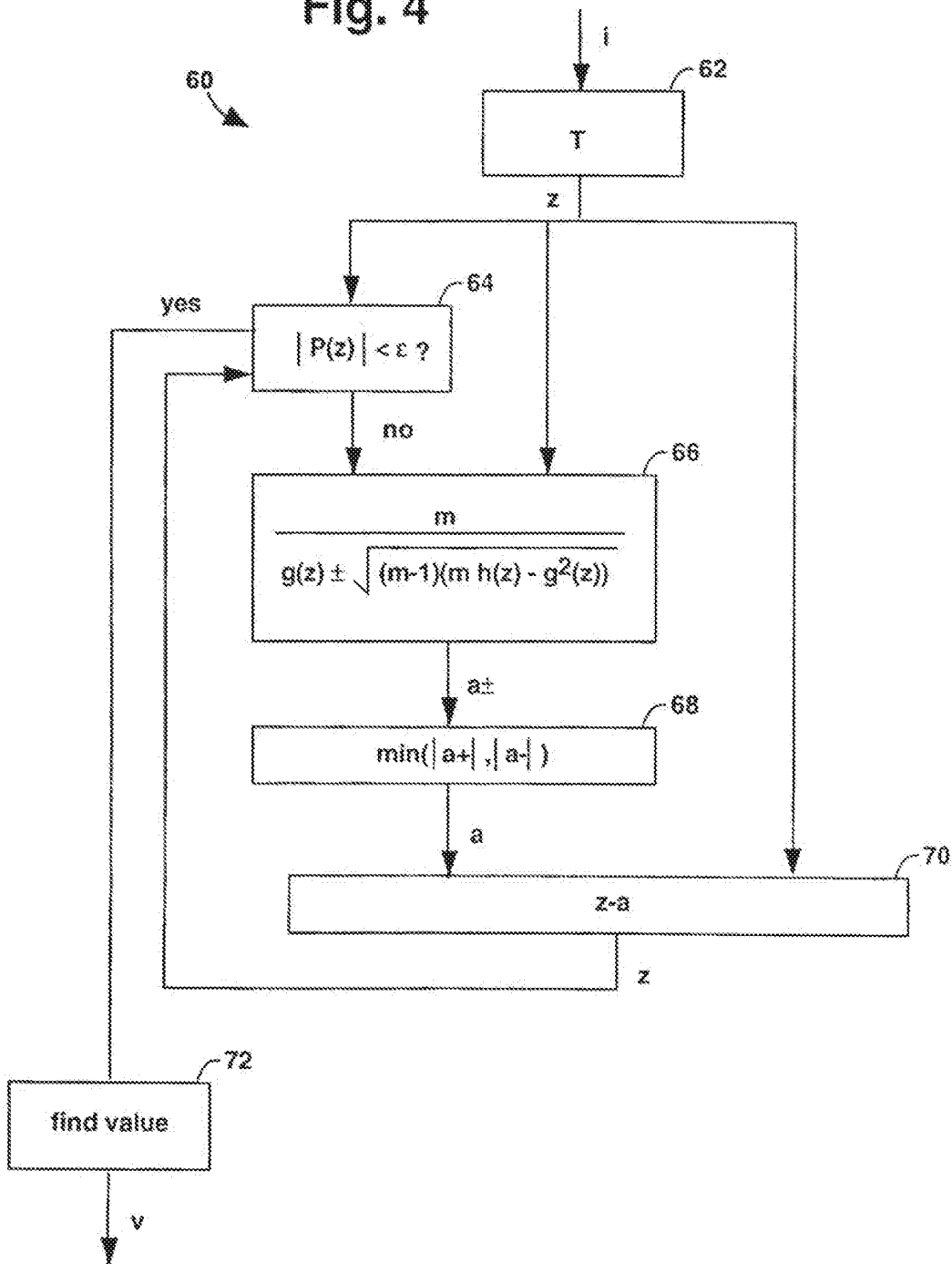


Fig. 4



## INTERNATIONAL SEARCH REPORT

International application No.  
PCT/US97/05847

<b>A. CLASSIFICATION OF SUBJECT MATTER</b>		
IPC(6) : G06K 9/36, 9/46 US CL : 382/232, 249; 395/13 According to International Patent Classification (IPC) or to both national classification and IPC		
<b>B. FIELDS SEARCHED</b>		
Minimum documentation searched (classification system followed by classification symbols) U.S. : 382/232, 249, 233, 241, 243, 247, 248, 253; 395/13, 612; 364/715.02		
Documentation searched other than minimum documentation to the extent that such documents are included in the fields searched		
Electronic data base consulted during the international search (name of data base and, where practicable, search terms used) APS, IEEE/IEEE Publications Ondisc Jan 1990 - Nov 1996 Search terms: complex, polynomial, root, compression, coding, genetic		
<b>C. DOCUMENTS CONSIDERED TO BE RELEVANT</b>		
Category*	Citation of document, with indication, where appropriate, of the relevant passages	Relevant to claim No.
A	US, A 5,343,554 (KOZA et al) 30 August 1994, col. 78, line 60 - col. 79, line 34.	1-3
<input type="checkbox"/> Further documents are listed in the continuation of Box C. <input type="checkbox"/> See patent family annex.		
* Special categories of cited documents:		
"A"	document defining the general state of the art which is not considered to be part of particular relevance	"T" later document published after the international filing date or priority date and not in conflict with the application but cited to underscored the principle or theory underlying the invention
"E"	earlier document published on or after the international filing date	"X" document of particular relevance; the claimed invention cannot be considered novel or cannot be considered to involve an inventive step when the document is taken alone
"L"	document which may throw doubts on priority claim(s) or which is cited to establish the publication date of another citation or other special reason (as specified)	"Y" document of particular relevance; the claimed invention cannot be considered to involve an inventive step when the document is combined with one or more other such documents, such combination being obvious to a person skilled in the art
"O"	document referring to an oral disclosure, use, exhibition or other means	"G" document member of the same patent family
"P"	document published prior to the international filing date but later than the priority date claimed	
Date of the actual completion of the international search 10 JULY 1997		Date of mailing of the international search report <b>20 AUG 1997</b>
Name and mailing address of the ISA/US Commissioner of Patents and Trademarks Box PCT Washington, D.C. 20231 Facsimile No. (703) 305-3230		Authorized officer B. Nguyen PHUOC TRAN Telephone No. (703) 305-4861

Form PCT/ISA/210 (second sheet)(July 1992)\*

RIV-1012 / Page 33 of 33

MICHAEL V. MESSINGER  
DIRECTOR  
(202) 772-8667  
MIKEM@SKGF.COM



May 16, 2016

Commissioner for Patents  
PO Box 1450  
Alexandria, VA 22313-1450

Confirmation No. 3403  
Art Unit 2634  
Attn: Mail Stop RCE

Re: U.S. Utility Patent Application  
Application No. 14/876,276; Filing Date: October 6, 2015  
For: **Video Data Compression Systems**  
Inventors: FALLON *et al.*  
Our Ref: 3421.005000C

Commissioner:

Transmitted herewith for appropriate action are the following documents:

1. Online Credit Card Payment Authorization in the amount of \$1,200.00 in payment of the fee under 37 C.F.R. § 1.17(e)(1);
2. Request for Continued Examination (PTO/SB/30);
3. Sixth Supplemental Information Disclosure Statement;
4. Form PTO/SB/08a (1 sheet) listing 6 documents (**US1-US4** and **FP1-FP2**);
5. Form PTO/SB/08b (2 sheets) listing 20 documents (**NPL1-NPL20**); and
6. Copies of cited documents (**FP1-FP2** and **NPL1-NPL20**).

In the event that extensions of time are necessary to prevent abandonment of this patent application, then such extensions of time are hereby petitioned.

Fee payment is provided through online credit card payment. The U.S. Patent and Trademark Office is hereby authorized to charge any fee deficiency, or credit any overpayment, to our Deposit Account No. 19-0036.

Respectfully submitted,

STERNE, KESSLER, GOLDSTEIN & FOX P.L.L.C.

A handwritten signature in black ink, appearing to read "Michael V. Messinger". The signature is fluid and cursive, written over a faint, dotted grid background.

Michael V. Messinger  
Attorney for Applicant  
Registration No. 37,575

MVM/MRM/wcf  
Enclosures



UNITED STATES PATENT AND TRADEMARK OFFICE

UNITED STATES DEPARTMENT OF COMMERCE
United States Patent and Trademark Office
Address: COMMISSIONER FOR PATENTS
P.O. Box 1450
Alexandria, Virginia 22313-1450
www.uspto.gov

NOTICE OF ALLOWANCE AND FEE(S) DUE

26111 7590 06/06/2016
STERNE, KESSLER, GOLDSTEIN & FOX P.L.L.C.
1100 NEW YORK AVENUE, N.W.
WASHINGTON, DC 20005

EXAMINER

BOCURE, TESFALDET

ART UNIT PAPER NUMBER

2634

DATE MAILED: 06/06/2016

Table with 5 columns: APPLICATION NO., FILING DATE, FIRST NAMED INVENTOR, ATTORNEY DOCKET NO., CONFIRMATION NO.
14/876,276 10/06/2015 James J. FALLON 3421.005000C 3403

TITLE OF INVENTION: Video Data Compression Systems

Table with 7 columns: APPLN. TYPE, ENTITY STATUS, ISSUE FEE DUE, PUBLICATION FEE DUE, PREV. PAID ISSUE FEE, TOTAL FEE(S) DUE, DATE DUE
nonprovisional UNDISCOUNTED \$960 \$0 \$0 \$960 09/06/2016

THE APPLICATION IDENTIFIED ABOVE HAS BEEN EXAMINED AND IS ALLOWED FOR ISSUANCE AS A PATENT. PROSECUTION ON THE MERITS IS CLOSED. THIS NOTICE OF ALLOWANCE IS NOT A GRANT OF PATENT RIGHTS. THIS APPLICATION IS SUBJECT TO WITHDRAWAL FROM ISSUE AT THE INITIATIVE OF THE OFFICE OR UPON PETITION BY THE APPLICANT. SEE 37 CFR 1.313 AND MPEP 1308.

THE ISSUE FEE AND PUBLICATION FEE (IF REQUIRED) MUST BE PAID WITHIN THREE MONTHS FROM THE MAILING DATE OF THIS NOTICE OR THIS APPLICATION SHALL BE REGARDED AS ABANDONED. THIS STATUTORY PERIOD CANNOT BE EXTENDED. SEE 35 U.S.C. 151. THE ISSUE FEE DUE INDICATED ABOVE DOES NOT REFLECT A CREDIT FOR ANY PREVIOUSLY PAID ISSUE FEE IN THIS APPLICATION. IF AN ISSUE FEE HAS PREVIOUSLY BEEN PAID IN THIS APPLICATION (AS SHOWN ABOVE), THE RETURN OF PART B OF THIS FORM WILL BE CONSIDERED A REQUEST TO REAPPLY THE PREVIOUSLY PAID ISSUE FEE TOWARD THE ISSUE FEE NOW DUE.

HOW TO REPLY TO THIS NOTICE:

I. Review the ENTITY STATUS shown above. If the ENTITY STATUS is shown as SMALL or MICRO, verify whether entitlement to that entity status still applies.

If the ENTITY STATUS is the same as shown above, pay the TOTAL FEE(S) DUE shown above.

If the ENTITY STATUS is changed from that shown above, on PART B - FEE(S) TRANSMITTAL, complete section number 5 titled "Change in Entity Status (from status indicated above)".

For purposes of this notice, small entity fees are 1/2 the amount of undiscounted fees, and micro entity fees are 1/2 the amount of small entity fees.

II. PART B - FEE(S) TRANSMITTAL, or its equivalent, must be completed and returned to the United States Patent and Trademark Office (USPTO) with your ISSUE FEE and PUBLICATION FEE (if required). If you are charging the fee(s) to your deposit account, section "4b" of Part B - Fee(s) Transmittal should be completed and an extra copy of the form should be submitted. If an equivalent of Part B is filed, a request to reapply a previously paid issue fee must be clearly made, and delays in processing may occur due to the difficulty in recognizing the paper as an equivalent of Part B.

III. All communications regarding this application must give the application number. Please direct all communications prior to issuance to Mail Stop ISSUE FEE unless advised to the contrary.

IMPORTANT REMINDER: Utility patents issuing on applications filed on or after Dec. 12, 1980 may require payment of maintenance fees. It is patentee's responsibility to ensure timely payment of maintenance fees when due.

**PART B - FEE(S) TRANSMITTAL**

**Complete and send this form, together with applicable fee(s), to: Mail Mail Stop ISSUE FEE  
 Commissioner for Patents  
 P.O. Box 1450  
 Alexandria, Virginia 22313-1450  
 or Fax (571)-273-2885**

**INSTRUCTIONS:** This form should be used for transmitting the ISSUE FEE and PUBLICATION FEE (if required). Blocks 1 through 5 should be completed where appropriate. All further correspondence including the Patent, advance orders and notification of maintenance fees will be mailed to the current correspondence address as indicated unless corrected below or directed otherwise in Block 1, by (a) specifying a new correspondence address; and/or (b) indicating a separate "FEE ADDRESS" for maintenance fee notifications.

CURRENT CORRESPONDENCE ADDRESS (Note: Use Block 1 for any change of address)

26111                      7590                      06/06/2016  
**STERNE, KESSLER, GOLDSTEIN & FOX P.L.L.C.**  
 1100 NEW YORK AVENUE, N.W.  
 WASHINGTON, DC 20005

Note: A certificate of mailing can only be used for domestic mailings of the Fee(s) Transmittal. This certificate cannot be used for any other accompanying papers. Each additional paper, such as an assignment or formal drawing, must have its own certificate of mailing or transmission.

**Certificate of Mailing or Transmission**

I hereby certify that this Fee(s) Transmittal is being deposited with the United States Postal Service with sufficient postage for first class mail in an envelope addressed to the Mail Stop ISSUE FEE address above, or being facsimile transmitted to the USPTO (571) 273-2885, on the date indicated below.

_____ (Depositor's name)
_____ (Signature)
_____ (Date)

APPLICATION NO.	FILING DATE	FIRST NAMED INVENTOR	ATTORNEY DOCKET NO.	CONFIRMATION NO.
14/876,276	10/06/2015	James J. FALLON	3421.005000C	3403

TITLE OF INVENTION: Video Data Compression Systems

APPLN. TYPE	ENTITY STATUS	ISSUE FEE DUE	PUBLICATION FEE DUE	PREV. PAID ISSUE FEE	TOTAL FEE(S) DUE	DATE DUE
nonprovisional	UNDISCOUNTED	\$960	\$0	\$0	\$960	09/06/2016

EXAMINER	ART UNIT	CLASS-SUBCLASS
BOCURE, TESFALDET	2634	375-240100

<p>1. Change of correspondence address or indication of "Fee Address" (37 CFR 1.363).</p> <p><input type="checkbox"/> Change of correspondence address (or Change of Correspondence Address form PTO/SB/122) attached.</p> <p><input type="checkbox"/> "Fee Address" indication (or "Fee Address" Indication form PTO/SB/47; Rev 03-02 or more recent) attached. <b>Use of a Customer Number is required.</b></p>	<p>2. For printing on the patent front page, list</p> <p>(1) The names of up to 3 registered patent attorneys or agents OR, alternatively, 1 _____</p> <p>(2) The name of a single firm (having as a member a registered attorney or agent) and the names of up to 2 registered patent attorneys or agents. If no name is listed, no name will be printed. 2 _____</p> <p>3 _____</p>
---	---

3. ASSIGNEE NAME AND RESIDENCE DATA TO BE PRINTED ON THE PATENT (print or type)

PLEASE NOTE: Unless an assignee is identified below, no assignee data will appear on the patent. If an assignee is identified below, the document has been filed for recordation as set forth in 37 CFR 3.11. Completion of this form is NOT a substitute for filing an assignment.

(A) NAME OF ASSIGNEE \_\_\_\_\_ (B) RESIDENCE: (CITY and STATE OR COUNTRY) \_\_\_\_\_

Please check the appropriate assignee category or categories (will not be printed on the patent):  Individual  Corporation or other private group entity  Government

<p>4a. The following fee(s) are submitted:</p> <p><input type="checkbox"/> Issue Fee</p> <p><input type="checkbox"/> Publication Fee (No small entity discount permitted)</p> <p><input type="checkbox"/> Advance Order - # of Copies _____</p>	<p>4b. Payment of Fee(s): (Please first reapply any previously paid issue fee shown above)</p> <p><input type="checkbox"/> A check is enclosed.</p> <p><input type="checkbox"/> Payment by credit card. Form PTO-2038 is attached.</p> <p><input type="checkbox"/> The director is hereby authorized to charge the required fee(s), any deficiency, or credits any overpayment, to Deposit Account Number _____ (enclose an extra copy of this form).</p>
---	---

5. Change in Entity Status (from status indicated above)

Applicant certifying micro entity status. See 37 CFR 1.29

Applicant asserting small entity status. See 37 CFR 1.27

Applicant changing to regular undiscounted fee status.

**NOTE:** Absent a valid certification of Micro Entity Status (see forms PTO/SB/15A and 15B), issue fee payment in the micro entity amount will not be accepted at the risk of application abandonment.

**NOTE:** If the application was previously under micro entity status, checking this box will be taken to be a notification of loss of entitlement to micro entity status.

**NOTE:** Checking this box will be taken to be a notification of loss of entitlement to small or micro entity status, as applicable.

NOTE: This form must be signed in accordance with 37 CFR 1.31 and 1.33. See 37 CFR 1.4 for signature requirements and certifications.

Authorized Signature \_\_\_\_\_ Date \_\_\_\_\_

Typed or printed name \_\_\_\_\_ Registration No. \_\_\_\_\_



UNITED STATES PATENT AND TRADEMARK OFFICE

UNITED STATES DEPARTMENT OF COMMERCE
United States Patent and Trademark Office
Address: COMMISSIONER FOR PATENTS
P.O. Box 1450
Alexandria, Virginia 22313-1450
www.uspto.gov

Table with 5 columns: APPLICATION NO., FILING DATE, FIRST NAMED INVENTOR, ATTORNEY DOCKET NO., CONFIRMATION NO.
14/876,276 10/06/2015 James J. FALLON 3421.005000C 3403

26111 7590 06/06/2016
STERNE, KESSLER, GOLDSTEIN & FOX P.L.L.C.
1100 NEW YORK AVENUE, N.W.
WASHINGTON, DC 20005

EXAMINER

BOCURE, TESFALDET

ART UNIT PAPER NUMBER

2634

DATE MAILED: 06/06/2016

Determination of Patent Term Adjustment under 35 U.S.C. 154 (b)
(Applications filed on or after May 29, 2000)

The Office has discontinued providing a Patent Term Adjustment (PTA) calculation with the Notice of Allowance.

Section 1(h)(2) of the AIA Technical Corrections Act amended 35 U.S.C. 154(b)(3)(B)(i) to eliminate the requirement that the Office provide a patent term adjustment determination with the notice of allowance. See Revisions to Patent Term Adjustment, 78 Fed. Reg. 19416, 19417 (Apr. 1, 2013). Therefore, the Office is no longer providing an initial patent term adjustment determination with the notice of allowance. The Office will continue to provide a patent term adjustment determination with the Issue Notification Letter that is mailed to applicant approximately three weeks prior to the issue date of the patent, and will include the patent term adjustment on the patent. Any request for reconsideration of the patent term adjustment determination (or reinstatement of patent term adjustment) should follow the process outlined in 37 CFR 1.705.

Any questions regarding the Patent Term Extension or Adjustment determination should be directed to the Office of Patent Legal Administration at (571)-272-7702. Questions relating to issue and publication fee payments should be directed to the Customer Service Center of the Office of Patent Publication at 1-(888)-786-0101 or (571)-272-4200.



## OMB Clearance and PRA Burden Statement for PTOL-85 Part B

The Paperwork Reduction Act (PRA) of 1995 requires Federal agencies to obtain Office of Management and Budget approval before requesting most types of information from the public. When OMB approves an agency request to collect information from the public, OMB (i) provides a valid OMB Control Number and expiration date for the agency to display on the instrument that will be used to collect the information and (ii) requires the agency to inform the public about the OMB Control Number's legal significance in accordance with 5 CFR 1320.5(b).

The information collected by PTOL-85 Part B is required by 37 CFR 1.311. The information is required to obtain or retain a benefit by the public which is to file (and by the USPTO to process) an application. Confidentiality is governed by 35 U.S.C. 122 and 37 CFR 1.14. This collection is estimated to take 12 minutes to complete, including gathering, preparing, and submitting the completed application form to the USPTO. Time will vary depending upon the individual case. Any comments on the amount of time you require to complete this form and/or suggestions for reducing this burden, should be sent to the Chief Information Officer, U.S. Patent and Trademark Office, U.S. Department of Commerce, P.O. Box 1450, Alexandria, Virginia 22313-1450. DO NOT SEND FEES OR COMPLETED FORMS TO THIS ADDRESS. SEND TO: Commissioner for Patents, P.O. Box 1450, Alexandria, Virginia 22313-1450. Under the Paperwork Reduction Act of 1995, no persons are required to respond to a collection of information unless it displays a valid OMB control number.

### Privacy Act Statement

**The Privacy Act of 1974 (P.L. 93-579)** requires that you be given certain information in connection with your submission of the attached form related to a patent application or patent. Accordingly, pursuant to the requirements of the Act, please be advised that: (1) the general authority for the collection of this information is 35 U.S.C. 2(b)(2); (2) furnishing of the information solicited is voluntary; and (3) the principal purpose for which the information is used by the U.S. Patent and Trademark Office is to process and/or examine your submission related to a patent application or patent. If you do not furnish the requested information, the U.S. Patent and Trademark Office may not be able to process and/or examine your submission, which may result in termination of proceedings or abandonment of the application or expiration of the patent.

The information provided by you in this form will be subject to the following routine uses:

1. The information on this form will be treated confidentially to the extent allowed under the Freedom of Information Act (5 U.S.C. 552) and the Privacy Act (5 U.S.C. 552a). Records from this system of records may be disclosed to the Department of Justice to determine whether disclosure of these records is required by the Freedom of Information Act.
2. A record from this system of records may be disclosed, as a routine use, in the course of presenting evidence to a court, magistrate, or administrative tribunal, including disclosures to opposing counsel in the course of settlement negotiations.
3. A record in this system of records may be disclosed, as a routine use, to a Member of Congress submitting a request involving an individual, to whom the record pertains, when the individual has requested assistance from the Member with respect to the subject matter of the record.
4. A record in this system of records may be disclosed, as a routine use, to a contractor of the Agency having need for the information in order to perform a contract. Recipients of information shall be required to comply with the requirements of the Privacy Act of 1974, as amended, pursuant to 5 U.S.C. 552a(m).
5. A record related to an International Application filed under the Patent Cooperation Treaty in this system of records may be disclosed, as a routine use, to the International Bureau of the World Intellectual Property Organization, pursuant to the Patent Cooperation Treaty.
6. A record in this system of records may be disclosed, as a routine use, to another federal agency for purposes of National Security review (35 U.S.C. 181) and for review pursuant to the Atomic Energy Act (42 U.S.C. 218(c)).
7. A record from this system of records may be disclosed, as a routine use, to the Administrator, General Services, or his/her designee, during an inspection of records conducted by GSA as part of that agency's responsibility to recommend improvements in records management practices and programs, under authority of 44 U.S.C. 2904 and 2906. Such disclosure shall be made in accordance with the GSA regulations governing inspection of records for this purpose, and any other relevant (i.e., GSA or Commerce) directive. Such disclosure shall not be used to make determinations about individuals.
8. A record from this system of records may be disclosed, as a routine use, to the public after either publication of the application pursuant to 35 U.S.C. 122(b) or issuance of a patent pursuant to 35 U.S.C. 151. Further, a record may be disclosed, subject to the limitations of 37 CFR 1.14, as a routine use, to the public if the record was filed in an application which became abandoned or in which the proceedings were terminated and which application is referenced by either a published application, an application open to public inspection or an issued patent.
9. A record from this system of records may be disclosed, as a routine use, to a Federal, State, or local law enforcement agency, if the USPTO becomes aware of a violation or potential violation of law or regulation.

<b>Notice of Allowability</b>	<b>Application No.</b> 14/876,276	<b>Applicant(s)</b> FALLON ET AL.	
	<b>Examiner</b> TESFALDET BOCURE	<b>Art Unit</b> 2634	<b>AIA (First Inventor to File) Status</b> No

**-- The MAILING DATE of this communication appears on the cover sheet with the correspondence address--**

All claims being allowable, PROSECUTION ON THE MERITS IS (OR REMAINS) CLOSED in this application. If not included herewith (or previously mailed), a Notice of Allowance (PTOL-85) or other appropriate communication will be mailed in due course. **THIS NOTICE OF ALLOWABILITY IS NOT A GRANT OF PATENT RIGHTS.** This application is subject to withdrawal from issue at the initiative of the Office or upon petition by the applicant. See 37 CFR 1.313 and MPEP 1308.

1.  This communication is responsive to RCE and IDS of 05/16/2016.  
 A declaration(s)/affidavit(s) under **37 CFR 1.130(b)** was/were filed on \_\_\_\_\_.
2.  An election was made by the applicant in response to a restriction requirement set forth during the interview on \_\_\_\_\_; the restriction requirement and election have been incorporated into this action.
3.  The allowed claim(s) is/are 1-30. As a result of the allowed claim(s), you may be eligible to benefit from the **Patent Prosecution Highway** program at a participating intellectual property office for the corresponding application. For more information, please see [http://www.uspto.gov/patents/init\\_events/pph/index.jsp](http://www.uspto.gov/patents/init_events/pph/index.jsp) or send an inquiry to [PPHfeedback@uspto.gov](mailto:PPHfeedback@uspto.gov).
4.  Acknowledgment is made of a claim for foreign priority under 35 U.S.C. § 119(a)-(d) or (f).

**Certified copies:**

a)  All    b)  Some    \*c)  None of the:

1.  Certified copies of the priority documents have been received.
2.  Certified copies of the priority documents have been received in Application No. \_\_\_\_\_.
3.  Copies of the certified copies of the priority documents have been received in this national stage application from the International Bureau (PCT Rule 17.2(a)).

\* Certified copies not received: \_\_\_\_\_.

Applicant has THREE MONTHS FROM THE "MAILING DATE" of this communication to file a reply complying with the requirements noted below. Failure to timely comply will result in ABANDONMENT of this application. **THIS THREE-MONTH PERIOD IS NOT EXTENDABLE.**

5.  CORRECTED DRAWINGS ( as "replacement sheets") must be submitted.  
 including changes required by the attached Examiner's Amendment / Comment or in the Office action of Paper No./Mail Date \_\_\_\_\_.  
**Identifying indicia such as the application number (see 37 CFR 1.84(c)) should be written on the drawings in the front (not the back) of each sheet. Replacement sheet(s) should be labeled as such in the header according to 37 CFR 1.121(d).**
6.  DEPOSIT OF and/or INFORMATION about the deposit of BIOLOGICAL MATERIAL must be submitted. Note the attached Examiner's comment regarding REQUIREMENT FOR THE DEPOSIT OF BIOLOGICAL MATERIAL.

**Attachment(s)**

- |  |   |
|--|---|
| 1. <input type="checkbox"/> Notice of References Cited (PTO-892)   | 5. <input checked="" type="checkbox"/> Examiner's Amendment/Comment       |
| 2. <input checked="" type="checkbox"/> Information Disclosure Statements (PTO/SB/08),<br>Paper No./Mail Date _____ | 6. <input type="checkbox"/> Examiner's Statement of Reasons for Allowance |
| 3. <input type="checkbox"/> Examiner's Comment Regarding Requirement for Deposit<br>of Biological Material         | 7. <input type="checkbox"/> Other _____.                                  |
| 4. <input type="checkbox"/> Interview Summary (PTO-413),<br>Paper No./Mail Date _____.                             |   |

/TESFALDET BOCURE/  
Primary Examiner, Art Unit 2634

**DETAILED ACTION**

1. The present application is being examined under the pre-AIA first to invent provisions.
2. This office action (Notice of Allowance) is in response to the IDS and RCE filed on 05/16/2016. The pending claims 1-30 are now allowed.

***Information Disclosure Statement***

3. The information disclosure statements (IDS) submitted on 05/16/2016 (two IDSs filed on the same date) are in compliance with the provisions of 37 CFR 1.97. Accordingly, the information disclosure statement is being considered by the examiner. Attached with this correspondence are the initialed copies of the IDSs.

***Conclusion***

4. Any inquiry concerning this communication or earlier communications from the examiner should be directed to TESHALDET BOCURE whose telephone number is (571)272-3015. The examiner can normally be reached on 8:30am-to-5:00pm.

If attempts to reach the examiner by telephone are unsuccessful, the examiner's supervisor, Daniel C. Washburn can be reached on 571-272-5551. The fax phone number for the organization where this application or proceeding is assigned is 571-273-8300.

Application/Control Number: 14/876,276  
Art Unit: 2634

Page 3

Information regarding the status of an application may be obtained from the Patent Application Information Retrieval (PAIR) system. Status information for published applications may be obtained from either Private PAIR or Public PAIR. Status information for unpublished applications is available through Private PAIR only. For more information about the PAIR system, see <http://pair-direct.uspto.gov>. Should you have questions on access to the Private PAIR system, contact the Electronic Business Center (EBC) at 866-217-9197 (toll-free). If you would like assistance from a USPTO Customer Service Representative or access to the automated information system, call 800-786-9199 (IN USA OR CANADA) or 571-272-1000.

/TESFALDET BOCURE/  
Primary Examiner, Art Unit 2634

/T. B./  
Primary Examiner, Art Unit 2634

## WEST Search History for Application 14876276

Creation Date: 2016052921:02

### Prior Art Searches

Query	DB	Hits	Op.	Plur.	Thes.	Date
((Fallen adj James).in. or (McErlain adj Stephen).in.)	PGPB, USPT, USOC, EPAB, JPAB, DWPI, TDBD	n/a	OR	YES		05-29-2016
((Fallen).in. or (McErlain).in.)	PGPB, USPT, USOC, EPAB, JPAB, DWPI, TDBD	n/a	OR	YES		05-29-2016
(select\$4 or choos\$4) near4 ((multiple or plural\$4 or two or three or four or five) near5 encoder\$) same ((assymetric\$ or (lempel adj2 ziv)) near4 (compressing or compression))	PGPB, USPT, USOC, EPAB, JPAB, DWPI, TDBD	n/a	OR	YES		05-29-2016
(select\$4 or choos\$4) near4 ((multiple or plural\$4 or two or three or four or five) near5 encoder\$) and ((assymetric\$ or (lempel adj2 ziv)) near4 (compressing or compression))	PGPB, USPT, USOC, EPAB, JPAB, DWPI, TDBD	n/a	OR	YES		05-29-2016
((select\$4 or choos\$4) near4 ((multiple or plural\$4 or two or three or four or five) near5 encoder\$) and ((assymetric\$ or (lempel adj2 ziv)) near4 (compressing or compression)) ) and @ad<=20010213	PGPB, USPT, USOC, EPAB, JPAB, DWPI, TDBD	n/a	OR	YES		05-29-2016
((select\$4 or choos\$4) near4 ((multiple or plural\$4 or two or three or four or five) near5 encoder\$) and ((assymetric\$ or (lempel adj2 ziv)) near4	PGPB, USPT, USOC,	n/a	OR	YES		05-29-2016

<b>((compressing or compression)) ) and ( (((Fallen adj James).in. or (McErlain adj Stephen).in.) ) or (((Fallen).in. or (McErlain).in.) ) )</b>	EPAB, JPAB, DWPI, TDBD					
<b>((select\$4 or choos\$4) near4 ((multiple or plural\$4 or two or three or four or five) near5 encoder\$) and ((assymetric\$ or (lempel adj2 ziv)) near4 (compressing or compression)) ) and ( (((Fallen adj James).in. or (McErlain adj Stephen).in.) ) )</b>	PGPB, USPT, USOC, EPAB, JPAB, DWPI, TDBD	n/a	OR	YES		05-29-2016
<b>(selecting or select or choose or choosing) near4 ((compress or compression or compressing) near4 (algorithm or algorithms or mode or modes)) same ((assymetric\$4 or (lempel adj2 ziv)) near4 (compressing or compression))</b>	PGPB, USPT, USOC, EPAB, JPAB, DWPI, TDBD	n/a	OR	YES		05-29-2016
<b>((compress or compression or compressing) near4 (algorithm or algorithms or mode or modes)) same (parameter or parameters or attribute or attributes) same (assymetric \$4near4 (compressing or compression))</b>	PGPB, USPT, USOC, EPAB, JPAB, DWPI, TDBD	n/a	OR	YES		05-29-2016
<b>((compress or compression or compressing) near4 (algorithm or algorithms or mode or modes)) same (parameter or parameters or attribute or attributes) same (assymetric\$4 near4 (compressing or compression))</b>	PGPB, USPT, USOC, EPAB, JPAB, DWPI, TDBD	n/a	OR	YES		05-29-2016
<b>((compress or compression or compressing) near4 (algorithm or algorithms or mode or modes)) same (parameter or parameters or attribute or attributes) same ((fast near4 slow) near4 (compressing or compression))</b>	PGPB, USPT, USOC, EPAB, JPAB, DWPI, TDBD	n/a	OR	YES		05-29-2016
<b>((multiple or plural\$4 or two or three or four or five) near5 encoder\$) same ((assymetric\$ or (lempel adj2 ziv)) near4 (compressing or compression))</b>	PGPB, USPT, USOC, EPAB, JPAB, DWPI, TDBD	n/a	OR	YES		05-29-2016

<p>((selecting or select or choose or choosing) near4 ((compress or compression or compressing) near4 (algorithm or algorithms or mode or modes)) same ((assymmetric\$4 or (lempel adj2 ziv)) near4 (compressing or compression)) ) and (((((H03M7/30))))   (((H03M7/3084))))   (((H03M7/6094))))   (((G06F15/7867))))   (((G06T1/60))))   (((H04N19/136))))).CPC. )</p>	<p>PGPB, USPT, USOC, EPAB, JPAB, DWPI, TDBD</p>	<p>n/a</p>	<p>OR</p>	<p>YES</p>		<p>05-29-2016</p>
<p>(((multiple or plural\$4 or two or three or four or five) near5 encoder\$) same ((assymmetric\$ or (lempel adj2 ziv)) near4 (compressing or compression)) ) and (((((H03M7/30))))   (((H03M7/3059))))   (((H03M7/3093))))   (((H04L69/04))))   (((H04N19/152))))   (((H04N9/8042))))).CPC. )</p>	<p>PGPB, USPT, USOC, EPAB, JPAB, DWPI, TDBD</p>	<p>n/a</p>	<p>OR</p>	<p>YES</p>		<p>05-29-2016</p>
<p>("20010019630"   "20010031092"   "20010032128"   "20010047473"   "20010052038"   "20020037035"   "20020069354"   "20020078241"   "20020080871"   "20020097172"   "20020101367"   "20020104891"   "20020126755"   "20020169950"   "20020191692"   "20030030575"   "20030034905"   "20030058873"   "20030084238").PN.</p>	<p>PGPB, USPT, USOC, EPAB, JPAB, DWPI, TDBD</p>	<p>n/a</p>	<p>OR</p>	<p>YES</p>		<p>05-29-2016</p>
<p>(((375/\$8))).ccls. or (((370/\$8))).ccls. or (((348/\$8))).ccls. or (((341/\$8))).ccls. or (((711/\$8))).ccls. or (((701/\$8))).ccls. or (((381/\$8))).ccls. or (((375/382))).ccls. )</p>	<p>PGPB, USPT, USOC, EPAB, JPAB, DWPI, TDBD</p>	<p>n/a</p>	<p>OR</p>	<p>YES</p>		<p>05-29-2016</p>
<p>(((375/\$8))).ccls. or (((370/\$8))).ccls. or (((348/\$8))).ccls. or (((341/\$8))).ccls. or (((711/\$8))).ccls. or (((701/\$8))).ccls. or (((381/\$8))).ccls. or (((375/382))).ccls. ) and ( ((select\$4 or choos\$4) near4 ((multiple or plural\$4 or two or three or four or five) near5 encoder\$) and ((assymmetric\$ or (lempel adj2 ziv)) near4 (compressing or compression)) ) or ((selecting or select or choose or choosing) near4 ((compress or compression or compressing) near4 (algorithm or algorithms or mode or modes)) same ((assymmetric\$4 or (lempel adj2 ziv)) near4 (compressing or compression)) ) or (((multiple or plural\$4 or two or three or four or five) near5 encoder\$) same ((assymmetric\$ or (lempel adj2 ziv)) near4 (compressing or compression)) ) )</p>	<p>PGPB, USPT, USOC, EPAB, JPAB, DWPI, TDBD</p>	<p>n/a</p>	<p>OR</p>	<p>YES</p>		<p>05-29-2016</p>
<p>(((375/240))).ccls. or (((375/240.01))).ccls. or (((375/240.02))).ccls. or (((341/50))).ccls. or</p>	<p>PGPB, USPT,</p>	<p>n/a</p>	<p>OR</p>	<p>YES</p>		<p>05-29-2016</p>

<p>((341/51)).ccls. or ((341/126)).ccls. ) and ( (select\$4 or choos\$4) near4 ((multiple or plural\$4 or two or three or four or five) near5 encoder\$) and ((assymetric\$ or (lempel adj2 ziv)) near4 (compressing or compression)) ) or ((selecting or select or choose or choosing) near4 ((compress or compression or compressing) near4 (algorithm or algorithms or mode or modes)) same ((assymetric\$4 or (lempel adj2 ziv)) near4 (compressing or compression)) ) or (((multiple or plural\$4 or two or three or four or five) near5 encoder\$) same ((assymetric\$ or (lempel adj2 ziv)) near4 (compressing or compression)) ) )</p>	<p>USOC, EPAB, JPAB, DWPI, TDBD</p>					
<p>((multiple or plural\$4 or two or three or four or five) near5 encoder\$) same ((assymetric\$3 or (lempel adj2 ziv) and (arithmetic)) near4 (compressing or compression))</p>	<p>PGPB, USPT, USOC, EPAB, JPAB, DWPI, TDBD</p>	<p>n/a</p>	<p>OR</p>	<p>YES</p>		<p>05-29-2016</p>
<p>( ((select\$4 or choos\$4) near4 ((multiple or plural\$4 or two or three or four or five) near5 encoder\$) and ((assymetric\$ or (lempel adj2 ziv)) near4 (compressing or compression)) ) or ((selecting or select or choose or choosing) near4 ((compress or compression or compressing) near4 (algorithm or algorithms or mode or modes)) same ((assymetric\$4 or (lempel adj2 ziv)) near4 (compressing or compression)) ) or (((multiple or plural\$4 or two or three or four or five) near5 encoder\$) same ((assymetric\$ or (lempel adj2 ziv)) near4 (compressing or compression)) ) or (((multiple or plural\$4 or two or three or four or five) near5 encoder\$) same ((assymetric\$3 or (lempel adj2 ziv) and (arithmetic)) near4 (compressing or compression)) ) )</p>	<p>PGPB, USPT, USOC, EPAB, JPAB, DWPI, TDBD</p>	<p>n/a</p>	<p>OR</p>	<p>YES</p>		<p>05-29-2016</p>
<p>((select\$4 or choos\$4) near4 ((multiple or plural\$4 or two or three or four or five) near5 encoder\$) and ((assymetric\$ or (lempel adj2 ziv)) near4 (compressing or compression)) or (selecting or select or choose or choosing) near4 ((compress or compression or compressing) near4 (algorithm or algorithms or mode or modes)) same ((assymetric\$4 or (lempel adj2 ziv)) near4 (compressing or compression)) or ((multiple or plural\$4 or two or three or four or five) near5 encoder\$) same ((assymetric\$ or (lempel adj2 ziv)) near4 (compressing or compression)) or ((multiple or plural\$4 or two or three or four or five) near5 encoder\$) same ((assymetric\$3 or (lempel adj2 ziv) and (arithmetic)) near4 (compressing or compression)) ) )</p>	<p>PGPB, USPT, USOC, EPAB, JPAB, DWPI, TDBD</p>	<p>n/a</p>	<p>OR</p>	<p>YES</p>		<p>05-29-2016</p>



<p>encoder\$) same ((assymetric\$3 or (lempel adj2 ziv) and (arithmetic)) near4 (compressing or compression)) ) and (((375/240))).ccls. or (((375/240.01))).ccls. or (((375/240.02))).ccls. or (((341/50))).ccls. or (((341/51))).ccls. or (((341/126))).ccls. ) and ((select\$4 or choos\$4) near4 ((multiple or plural\$4 or two or three or four or five) near5 encoder\$) and ((assymetric\$ or (lempel adj2 ziv)) near4 (compressing or compression)) or (selecting or select or choose or choosing) near4 ((compress or compression or compressing) near4 (algorithm or algorithms or mode or modes)) same ((assymetric\$4 or (lempel adj2 ziv)) near4 (compressing or compression)) or ((multiple or plural\$4 or two or three or four or five) near5 encoder\$) same ((assymetric\$ or (lempel adj2 ziv)) near4 (compressing or compression)) ) )</p>						
<p>((select\$4 or choos\$4) near4 ((multiple or plural\$4 or two or three or four or five) near5 encoder\$) and ((assymetric\$ or (lempel adj2 ziv)) near4 (compressing or compression)) or (selecting or select or choose or choosing) near4 ((compress or compression or compressing) near4 (algorithm or algorithms or mode or modes)) same ((assymetric\$4 or (lempel adj2 ziv)) near4 (compressing or compression)) or ((multiple or plural\$4 or two or three or four or five) near5 encoder\$) same ((assymetric\$ or (lempel adj2 ziv)) near4 (compressing or compression)) or ((multiple or plural\$4 or two or three or four or five) near5 encoder\$) same ((assymetric\$3 or (lempel adj2 ziv) and (arithmetic)) near4 (compressing or compression)) ) ) and (((375/\$8))).ccls. or (((370/\$8))).ccls. or (((348/\$8))).ccls. or (((341/\$8))).ccls. or (((711/\$8))).ccls. or (((701/\$8))).ccls. or (((381/\$8))).ccls. or (((375/382))).ccls. ) )</p>	<p>PGPB, USPT, USOC, EPAB, JPAB, DWPI, TDBD</p>	<p>n/a</p>	<p>OR</p>	<p>YES</p>		<p>05-29-2016</p>
<p>((select\$4 or choos\$4) near4 ((multiple or plural\$4 or two or three or four or five) near5 encoder\$) and ((assymetric\$ or (lempel adj2 ziv)) near4 (compressing or compression)) or (selecting or select or choose or choosing) near4 ((compress or compression or compressing) near4 (algorithm or algorithms or mode or modes)) same ((assymetric\$4 or (lempel adj2 ziv)) near4 (compressing or compression)) or ((multiple or plural\$4 or two or three or four or five) near5 encoder\$) same ((assymetric\$ or (lempel adj2 ziv))</p>	<p>PGPB, USPT, USOC, EPAB, JPAB, DWPI, TDBD</p>	<p>n/a</p>	<p>OR</p>	<p>YES</p>		<p>05-29-2016</p>

<p>near4 (compressing or compression)) or ((multiple or plural\$4 or two or three or four or five) near5 encoder\$) same ((assymetric\$3 or (lempel adj2 ziv) and (arithmetic)) near4 (compressing or compression)) ) ) and (((H03M7/30))   ((H03M7/3059))   ((H03M7/3084))   ((H03M7/6094))   ((H03M7/3088))   ((H03M7/6023))   ((H03M7/6064))   ((H04N19/152))   ((G11B20/00007))),CPC. )</p>						
<p>("20150334390"   "3394352"   "3490690"   "4021782"   "4032893"   "4054951"   "4127518"   "4302775"   "4325085"   "4360840"   "4386416"   "4394774"   "4464650"   "4494108"   "4499499"   "4574351"   "4626829"   "4646061"   "4682150"   "4701745").PN.</p>	<p>PGPB, USPT, USOC, EPAB, JPAB, DWPI, TDBD</p>	<p>n/a</p>	<p>OR</p>	<p>YES</p>		<p>05-29-2016</p>
<p>((("20150334390"   "3394352"   "3490690"   "4021782"   "4032893"   "4054951"   "4127518"   "4302775"   "4325085"   "4360840"   "4386416"   "4394774"   "4464650"   "4494108"   "4499499"   "4574351"   "4626829"   "4646061"   "4682150"   "4701745").PN. ) and (((select\$4 or choos\$4) near4 ((multiple or plural\$4 or two or three or four or five) near5 encoder\$) and ((assymetric\$ or (lempel adj2 ziv)) near4 (compressing or compression)) or (selecting or select or choose or choosing) near4 ((compress or compression or compressing) near4 (algorithm or algorithms or mode or modes)) same ((assymetric\$4 or (lempel adj2 ziv)) near4 (compressing or compression)) or ((multiple or plural\$4 or two or three or four or five) near5 encoder\$) same ((assymetric\$ or (lempel adj2 ziv)) near4 (compressing or compression)) or ((multiple or plural\$4 or two or three or four or five) near5 encoder\$) same ((assymetric\$3 or (lempel adj2 ziv) and (arithmetic)) near4 (compressing or compression)) ) )</p>	<p>PGPB, USPT, USOC, EPAB, JPAB, DWPI, TDBD</p>	<p>n/a</p>	<p>OR</p>	<p>YES</p>		<p>05-29-2016</p>
<p>("4558302"   "4568983"   "5046119"   "5227878"   "5333212"   "5379351"   "5379356"   "5402146"   "5408542"   "5684478"   "5870036"   "6023233"   "6092071"   "6169499"   "6215983"   "6370631"   "6404919"   "20160029018"   "5479210"   "5590317"   "5710562"   "6233017"   "6744926"   "7496586"   "5479210"   "5590317"   "5710562"   "6233017"   "6744926"   "7496586"   "3560639"   "5467134"   "5623483"   "5664226").PN.</p>	<p>PGPB, USPT, USOC, EPAB, JPAB, DWPI, TDBD</p>	<p>n/a</p>	<p>OR</p>	<p>YES</p>		<p>05-29-2016</p>
<p>(((select\$4 or choos\$4) near4 ((multiple or plural\$4 or two or three or four or five) near5 encoder\$)</p>	<p>PGPB, USPT,</p>	<p>60</p>	<p>OR</p>	<p>YES</p>		<p>05-29-2016</p>

<p>and ((assymmetric\$ or (lempel adj2 ziv)) near4 (compressing or compression)) or (selecting or select or choose or choosing) near4 ((compress or compression or compressing) near4 (algorithm or algorithms or mode or modes)) same ((assymmetric\$4 or (lempel adj2 ziv)) near4 (compressing or compression)) or ((multiple or plural\$4 or two or three or four or five) near5 encoder\$) same ((assymmetric\$ or (lempel adj2 ziv)) near4 (compressing or compression)) or ((multiple or plural\$4 or two or three or four or five) near5 encoder\$) same ((assymmetric\$3 or (lempel adj2 ziv) and (arithmetic)) near4 (compressing or compression)) ) ) and ((H03M7/30)   (H03M7/3084)   (H03M7/6094)   (H04N19/164)   HO4N19/176   (H04N19/103)).CPC.</p>	<p>USOC, EPAB, JPAB, DWPI, TDBD</p>					
<p>("20160127512"   "20160127513"   "5479638"   "5771354").PN.</p>	<p>PGPB, USPT, USOC, EPAB, JPAB, DWPI, TDBD</p>	<p>8</p>	<p>OR</p>	<p>YES</p>		<p>05-29-2016</p>


**UNITED STATES PATENT AND TRADEMARK OFFICE**

UNITED STATES DEPARTMENT OF COMMERCE  
**United States Patent and Trademark Office**  
 Address: COMMISSIONER FOR PATENTS  
 P.O. Box 1450  
 Alexandria, Virginia 22313-1450  
 www.uspto.gov

**BIB DATA SHEET**
**CONFIRMATION NO. 3403**

SERIAL NUMBER	FILING or 371(c) DATE	CLASS	GROUP ART UNIT	ATTORNEY DOCKET NO.		
14/876,276	10/06/2015	375	2634	3421.005000C		
<b>RULE</b>						
<b>APPLICANTS</b> Realtime Data, LLC, Armonk, NY; <b>INVENTORS</b> James J. FALLON, Armonk, NY; Stephen J. MCERLAIN, Astoria, NY; <b>** CONTINUING DATA *****</b> This application is a CON of 14/733,565 06/08/2015 which is a CON of 14/577,286 12/19/2014 ABN which is a CON of 14/134,933 12/19/2013 PAT 8929442 which is a CON of 14/033,245 09/20/2013 PAT 8934535 which is a CON of 13/154,239 06/06/2011 PAT 8553759 which is a CON of 12/123,081 05/19/2008 PAT 8073047 which is a CON of 10/076,013 02/13/2002 PAT 7386046 which claims benefit of 60/268,394 02/13/2001 <b>** FOREIGN APPLICATIONS *****</b> <b>** IF REQUIRED, FOREIGN FILING LICENSE GRANTED **</b> 10/20/2015						
Foreign Priority claimed <input type="checkbox"/> Yes <input checked="" type="checkbox"/> No	35 USC 119(a-d) conditions met <input type="checkbox"/> Yes <input checked="" type="checkbox"/> No	<input type="checkbox"/> Met after Allowance	<b>STATE OR COUNTRY</b>	<b>SHEETS DRAWINGS</b>	<b>TOTAL CLAIMS</b>	<b>INDEPENDENT CLAIMS</b>
Verified and /TESFALDET BOCURE/ Acknowledged Examiner's Signature	Initials	NY	4	30	2	
<b>ADDRESS</b>						
STERNE, KESSLER, GOLDSTEIN & FOX P.L.L.C. 1100 NEW YORK AVENUE, N.W. WASHINGTON, DC 20005 UNITED STATES						
<b>TITLE</b>						
Video Data Compression Systems						
<b>FILING FEE RECEIVED</b> 2400	FEES: Authority has been given in Paper No. _____ to charge/credit DEPOSIT ACCOUNT No. _____ for following:			<input type="checkbox"/> All Fees <input type="checkbox"/> 1.16 Fees (Filing) <input type="checkbox"/> 1.17 Fees (Processing Ext. of time) <input type="checkbox"/> 1.18 Fees (Issue) <input type="checkbox"/> Other _____ <input type="checkbox"/> Credit		

IN THE UNITED STATES PATENT AND TRADEMARK OFFICE

Inventors: FALLON *et al.*

Confirmation No.: 3403

Applicant: Realtime Data, LLC

Art Unit: 2634

Application No.: 14/876,276

Examiner: BOCURE, TESHALDET

Filing Date: October 6, 2015

Atty. Docket: 3421.005000C

Title: **Video Data Compression Systems**

**Sixth Supplemental Information Disclosure Statement**

*Mail Stop RCE*

Commissioner for Patents  
PO Box 1450  
Alexandria, VA 22313-1450

Commissioner:

Notice of Prior and Concurrent Proceedings

Applicant hereby calls to the attention of the Patent and Trademark Office the following reexamination proceedings involving patents that are commonly-assigned with the patent in the above-identified patent application:

<b>Proceeding</b>	<b>Status</b>
Inter Partes Reexamination of U.S. Patent No. 6,604,158 (Control No. 95/000,486)	Inter Partes Reexamination Certificate issued 10/10/2012
Inter Partes Reexamination of U.S. Patent No. 7,321,937 (Control No. 95/000,466)	Inter Partes Reexamination Certificate issued 05/15/2012
Inter Partes Reexamination of U.S. Patent No. 6,604,158 (Control No. 95/000,453)	Terminated
Ex Parte Reexamination of U.S. Patent No. 6,601,104 (Control No. 90/009,428)	Ex Parte Reexamination Certificate issued 02/28/2012
Inter Partes Reexamination of U.S. Patent No. 7,378,992 (Control No. 95/000,478)	Inter Partes Reexamination Certificate issued 10/04/2012
Inter Partes Reexamination of U.S. Patent No. 6,624,761 (Control No. 95/000,464)	Inter Partes Reexamination Certificate issued 06/12/2012
Inter Partes Reexamination of U.S. Patent No. 7,161,506 (Control No. 95/000,479)	Inter Partes Reexamination Certificate issued 05/22/2012

/Teshaldet Bocure/

05/29/2016

ALL REFERENCES CONSIDERED EXCEPT WHERE LINED THROUGH. /T.B./

<b>Proceeding</b>	<b>Status</b>
Inter Partes Reexamination of U.S. Patent No. 7,714,747 (Control No. 95/001,517)	Appeal to the Court of Appeals for the Federal Circuit dismissed 6/4/2015
Inter Partes Reexamination of U.S. Patent No. 7,417,568 (Control No. 95/001,533)	Decision on Appeal mailed 10/29/2015
Inter Partes Reexamination of U.S. Patent No. 7,777,651 (Control No. 95/001,581)	Decision on Appeal mailed 10/29/2015
Inter Partes Reexamination of U.S. Patent No. 7,400,274 (Control No. 95/001,544)	Decision on Appeal mailed 10/29/2015

Applicant hereby calls to the attention of the Patent and Trademark Office the following reexamination proceedings filed by Cellco Partnership d/b/a Verizon Wireless, involving patents that are commonly-assigned with the patent in the above-identified patent application:

<b>Proceeding</b>	<b>Status</b>
Inter Partes Reexamination of U.S. Patent No. 7,321,937 (Control No. 95/001,922)	Inter Partes Reexamination Certificate issued 12/05/2013
Inter Partes Reexamination of U.S. Patent No. 6,604,158 (Control No. 95/001,923)	Inter Partes Reexamination Certificate issued 04/17/2015
Inter Partes Reexamination of U.S. Patent No. 7,352,300 (Control No. 95/001,924)	Inter Partes Reexamination Certificate issued 08/04/2014
Inter Partes Reexamination of U.S. Patent No. 7,395,345 (Control No. 95/001,925)	Inter Partes Reexamination Certificate issued 11/03/2014
Inter Partes Reexamination of U.S. Patent No. 7,161,506 (Control No. 95/001,926)	Inter Partes Reexamination Certificate issued 01/08/2014
Inter Partes Reexamination of U.S. Patent No. 7,415,530 (Control No. 95/001,927)	Inter Partes Reexamination Certificate issued 08/16/2013
Inter Partes Reexamination of U.S. Patent No. 7,378,992 (Control No. 95/001,928)	Inter Partes Reexamination Certificate issued 01/08/2014

Applicant invites the Examiner to review the Requests for Reexamination, issued Office Actions, replies, and any other papers in the above-identified reexamination proceedings. If the Examiner is unable to obtain copies of papers in any reexamination proceeding, copies can be

/Tsfaldet Bocure/

05/29/2016

Atty. Dkt. No. 3421.005000C

ALL REFERENCES CONSIDERED EXCEPT WHERE LINED THROUGH. /T.B./

provided to the Examiner upon request. Those documents which may be material that are not already of record in this patent application are listed on the accompanying Form PTO/SB/08.

Applicant hereby calls to the attention of the Patent and Trademark Office the following *inter partes* review proceedings involving patents that are commonly-assigned with the patent in the above-identified patent application:

<b>Proceeding</b>	<b>Patent</b>	<b>Status</b>
<i>Oracle America, Inc. v. Realtime Data, LLC</i> , IPR2016-00373	7,378,992	Patent Owner Preliminary Response filed April 7, 2016
<i>Oracle America, Inc. v. Realtime Data, LLC</i> , IPR2016-00374	8,643,513	Patent Owner Preliminary Response filed April 8, 2016
<i>Oracle America, Inc. v. Realtime Data, LLC</i> , IPR2016-00375	7,415,530	Patent Owner Preliminary Response filed April 11, 2016
<i>Oracle America, Inc. v. Realtime Data, LLC</i> , IPR2016-00376	7,415,530	Patent Owner Preliminary Response filed April 11, 2016
<i>Oracle America, Inc. v. Realtime Data, LLC</i> , IPR2016-00377	9,116,908	Patent Owner Preliminary Response filed April 11, 2016
<i>SAP America Inc., et al. v. Realtime Data, LLC d/b/a IXO</i> , IPR2016-00783	6,597,812	Petition filed April 1, 2016
<i>Dell Inc., et al. v. Realtime Data, LLC</i> , IPR2016-00878	7,415,530	Petition filed April 22, 2016
<i>Dell Inc., et al. v. Realtime Data, LLC</i> , IPR2016-00972	7,415,530	Petition filed April 29, 2016
<i>Riverbed Technology, Inc. et al. v. Realtime Data, LLC</i> , IPR2016-00978	8,643,513	Petition filed April 29, 2016
<i>Riverbed Technology, Inc. et al. v. Realtime Data, LLC</i> , IPR2016-00980	7,378,992	Petition filed April 29, 2016
<i>Dell Inc., et al. v. Realtime Data, LLC</i> , IPR2016-01002	9,116,908	Petition filed May 5, 2016

/Tesfaldet Bocure/

05/29/2016

Atty. Dkt. No. 3421.005000C

ALL REFERENCES CONSIDERED EXCEPT WHERE LINED THROUGH. /T.B./

Applicant invites the Examiner to review the petitions for *inter partes* review and any other papers in the above-identified *inter partes* review proceedings. If the Examiner is unable to obtain copies of papers in any *inter partes* review proceeding, copies can be provided to the Examiner upon request. Those documents which may be material that are not already of record in this patent application are listed on the accompanying Form PTO/SB/08 as documents **US1-US2, FP1-FP2,** and **NPL8-NPL19.**

Notice of Related Litigation

Applicant notifies the Patent and Trademark Office of the following litigation involving U.S. Patents commonly-owned with the current patent application, the subject matter of which may be related to the present patent application:

No.	Case	Status
1	<i>Realtime Data LLC d/b/a IXO v. Packeteer, Inc. et al.</i> , No. 6:08-cv-00144-LED (E.D. Texas)	Dismissed

Applicant also notifies the Patent and Trademark Office of the following additional litigation involving U.S. Patents commonly-owned with the current patent application, the subject matter of which may be related to the present patent application:

No.	Case	Status
2	<i>Realtime Data LLC d/b/a IXO v. Thomson Reuters Corporation et al.</i> No. 1:11-cv-06698-RJH (S.D. New York) (transferred from E.D. Texas; 6:09-cv-00333-LED)	Case Terminated 11/9/2012; Opinion of the Court of Appeals for the Federal Circuit received 01/27/2014

/Tsfaldet Bocure/

05/29/2016

Atty. Dkt. No. 3421.005000C

ALL REFERENCES CONSIDERED EXCEPT WHERE LINED THROUGH. /T.B./



3	<i>Realtime Data LLC d/b/a IXO v. Morgan Stanley et al.</i> , No. 1:11-cv-06696-RJH (S.D. New York) (transferred from E.D. Texas; 6:09-cv-00326-LED)	Case Terminated 11/9/2012; Opinion of the Court of Appeals for the Federal Circuit received 01/27/2014
4	<i>Realtime Data LLC d/b/a IXO v. CME Group Inc., et al.</i> , No. 1:11-cv-06697-RJH (S.D. New York) (transferred from E.D. Texas; No. 6:09-cv-00327-LED)	Case Terminated 11/9/2012; Opinion of the Court of Appeals for the Federal Circuit received 01/27/2014
5	<i>Chicago Board Options Exchange, Inc., v. Realtime Data LLC d/b/a IXO</i> , No. 09-cv-4486 (N.D. Ill.)	Dismissed
6	<i>Thomson Reuters Corporation v. Realtime Data, LLC d/b/a IXO</i> , No. 1:09-cv-07868-RMB (S.D.N.Y)	Consolidated with Case No. 2
7	<i>Realtime Data, LLC d/b/a IXO v. CME Group Inc., et al. (II)</i> , No. 6:10-cv-246 (E.D. Texas)	Consolidated with Case No. 4
8	<i>Realtime Data LLC d/b/a IXO v. Thomson Reuters Corporation et al. (II)</i> , No. 6:10-cv-247 (E.D. Texas)	Consolidated with Case No. 2
9	<i>Realtime Data, LLC d/b/a IXO v. Morgan Stanley, et al. (II)</i> , No. 6:10-cv-248 (E.D. Texas)	Consolidated with Case No. 3
10	<i>Realtime Data, LLC d/b/a IXO v. MetroPCS Texas, LLC et al.</i> , No. 6:10-cv-00493 (E.D. Texas)	Appeal Terminated
11	<i>Realtime Data, LLC d/b/a IXO v. Microsoft Corporation, et al.</i> , No. 4:14-cv-00827 (E.D. Texas)	Dismissed May 1, 2015
12	<i>Realtime Data, LLC d/b/a IXO v. Actian Corporation, et al.</i> , No. 6:15-cv-00463 (E.D. Texas)	Amended Complaints for Patent Infringement filed September 14, 2015
13	<i>Realtime Data, LLC d/b/a IXO v. Dropbox, Inc.</i> , No. 6:15-cv-00465 (E.D. Texas)	Transferred to the Northern District of California, January 16, 2016; Answer to Amended Complaint filed February 4, 2016
14	<i>Realtime Data, LLC d/b/a IXO v. Echostar Corporation, et al.</i> , No. 6:15-cv-00466 (E.D. Texas)	Consolidated with Case No. 12; Answer to Amended Complaint filed February 4, 2016

/Tesfaldet Bocure/

05/29/2016

Atty. Dkt. No. 3421.005000C

ALL REFERENCES CONSIDERED EXCEPT WHERE LINED THROUGH. /T.B./

15	<i>Realtime Data, LLC d/b/a IXO v. Riverbed Technology, Inc., et al.</i> , No. 6:15-cv-00468 (E.D. Texas)	Consolidated with Case No. 12; Second Amended Complaint for Infringement filed February 2, 2016
16	<i>Realtime Data, LLC d/b/a IXO v. BMC Software, Inc.</i> , No. 6:15-cv-00464 (E.D. Texas)	Terminated October 5, 2015
17	<i>Realtime Data, LLC d/b/a IXO v. Oracle America, Inc., et al.</i> , No. 6:15-cv-00467 (E.D. Texas)	Consolidated with Case No. 12
18	<i>Realtime Data, LLC d/b/a IXO v. SAP America, Inc., et al.</i> , No. 6:15-cv-00469 (E.D. Texas)	Consolidated with Case No. 12; Answers to Amended Complaint filed February 4, 2016
19	<i>Realtime Data, LLC d/b/a IXO v. Teradata Corporation, et al.</i> , No. 5:16-cv-01836 (N.D. Cal.) (formerly no. 6:15-cv-00470 (E.D. Texas))	Transferred to the Northern District of California, January 19, 2016
20	<i>Realtime Data, LLC d/b/a IXO v. Apple Inc.</i> , No. 6:15-cv-00885 (E.D. Texas)	Order Granting Motion to Stay entered February 11, 2016
21	<i>Realtime Data LLC d/b/a IXO v. Hewlett Packard Enterprise Co., et al.</i> , No. 6:16-cv-00086 (E.D. Texas)	Complaint filed February 26, 2016
22	<i>Realtime Data LLC d/b/a IXO v. Oracle America, Inc.</i> , No. 6:16-cv-00088 (E.D. Texas)	Complaint filed February 26, 2016
23	<i>Realtime Data LLC d/b/a IXO v. CenturyLink, Inc., et al.</i> , No. 6:16-cv-00087 (E.D. Texas)	Complaint filed February 26, 2016
24	<i>Realtime Data LLC d/b/a IXO v. Dell, Inc., et al.</i> , No. 6:16-cv-00089 (E.D. Texas)	Complaint filed February 26, 2016
25	<i>Realtime Data LLC d/b/a IXO v. Teradata Operations, Inc.</i> , No. 2:16-cv-02743 (C.D. Cal.)	Complaint filed April 21, 2016

An updated court docket for a pending litigation is submitted herewith as document **NPL20**.

Information Disclosure Statement

Listed on accompanying IDS Forms PTO/SB/08a equivalent and PTO/SB/08b equivalent are documents that may be considered material to the patentability of this application as defined in

/Tesfaldet Bocure/

05/29/2016

Atty. Dkt. No. 3421.005000C

ALL REFERENCES CONSIDERED EXCEPT WHERE LINED THROUGH. /T.B./

37 C.F.R. §1.56, and in compliance with the duty of disclosure requirements of 37 C.F.R. §§ 1.97 and 1.98.

Applicant has listed publication dates on the attached IDS Forms based on information presently available to the undersigned. However, the listed publication dates should not be construed as an admission that the information was actually published on the date indicated.

Applicant reserves the right to establish the patentability of the claimed invention over any of the information provided herewith, and/or to prove that this information may not be prior art, and/or to prove that this information may not be enabling for the teachings purportedly offered.

This statement should not be construed as a representation that a search has been made, or that information more material to the examination of the present patent application does not exist. The Examiner is specifically requested not to rely solely on the material submitted herewith.

Filing under 37 C.F.R. § 1.97(b). This Information Disclosure Statement is being filed before the mailing of a first Office Action after the filing of a request for continued examination under 37 C.F.R. § 1.114. No statement or fee is required.

Copies of documents **FP1-FP2** and **NPL1-NPL20** are submitted. However, in accordance with 37 C.F.R. § 1.98(a)(2)(ii), no copies of the U.S. patents and patent application publications cited as documents **US1-US4** on the attached IDS Forms are submitted.

Applicant submits herewith Office Actions from the co-pending U.S. Patent Application Nos.:

Document **NPL6** is a copy of a Notice of Allowance mailed April 26, 2016, in the prosecution of co-pending, commonly-assigned U.S. Patent Application No. 14/727,309.

/Tsfaldet Bocure/

05/29/2016

Atty. Dkt. No. 3421.005000C

ALL REFERENCES CONSIDERED EXCEPT WHERE LINED THROUGH. /T.B./

Comcast - Exhibit 1002, page 1194

Document **NPL7** is a copy of a Notice of Allowance mailed May 6, 2016, in the prosecution of co-pending, commonly-assigned U.S. Patent Application No. 14/733,565.

The identification of these Office Actions is not to be construed as a waiver of secrecy as to those applications now or upon issuance of the present application as a patent. The Examiner is respectfully requested to consider the cited applications and the art cited therein during examination.

It is expected that the examiner will review the prosecution and cited art in the parent application nos. 14/733,565, filed June 8, 2015 (now pending); 14/577,286, filed December 19, 2014 (now abandoned); 14/134,933, filed December 19, 2013 (now U.S. Patent No. 8,929,442); 14/033,245, filed September 20, 2013 (now U.S. Patent No. 8,934,535); 13/154,239, filed June 6, 2011 (now U.S. Patent No. 8,553,759); 12/123,081, filed May 19, 2008 (now U.S. Patent No. 8,073,047); and 10/076,013, filed February 13, 2002 (now U.S. Patent No. 7,386,046), in accordance with MPEP 2001.06(b), and indicate in the next communication from the office that the art cited in the earlier prosecution history has been reviewed in connection with the present application.

It is respectfully requested that the Examiner initial and return a copy of the enclosed IDS Forms, and indicate in the official file wrapper of this patent application that the documents have been considered.

/Tsfaldet Bocure/

05/29/2016

Atty. Dkt. No. 3421.005000C

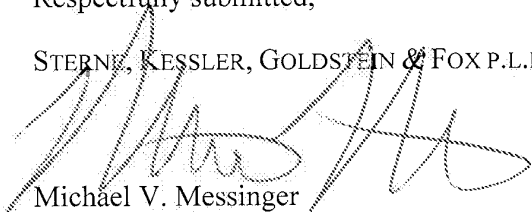
ALL REFERENCES CONSIDERED EXCEPT WHERE LINED THROUGH. /T.B./

Comcast - Exhibit 1002, page 1195

The U.S. Patent and Trademark Office is hereby authorized to charge any fee deficiency, or credit any overpayment, to our Deposit Account No. 19-0036.

Respectfully submitted,

STERNE, KESSLER, GOLDSSTEIN & FOX P.L.L.C.



Michael V. Messinger  
Attorney for Applicant  
Registration No. 37,575

Date: May 16, 2016

1100 New York Avenue, N.W.  
Washington, D.C. 20005-3934  
(202) 371-2600

2810062\_1.DOCX



Substitute for form 1449/PTO		<b>Complete if Known</b>	
<b>SIXTH SUPPLEMENTAL INFORMATION DISCLOSURE STATEMENT BY APPLICANT</b> <i>(Use as many sheets as necessary)</i>		Application Number	14/876,276
		Filing Date	October 6, 2015
		First Named Inventor	James J. FALLON
		Art Unit	2634
		Examiner Name	BOCURE, TESFALDET
		Attorney Docket Number	3421.005000C
Sheet	1	of	2

NON PATENT LITERATURE DOCUMENTS			
Examiner Initials*	Cite No. <sup>1</sup>	Include name of the author (in CAPITAL LETTERS), title of the article (when appropriate), title of the item (book, magazine, journal, serial, symposium, catalog, etc.), date, page(s), volume-issue number(s), publisher, city and/or country where published	T <sup>2</sup>
	NPL1	Joint Claim Construction and Prehearing Statement, filed in Realtime Data LLC d/b/a IXO v. Actian Corporation, et al., Case No. 6:15-cv-00463-RWS-JDL (E.D. Tex.), filed April 18, 2016; 26 pages.	
	NPL2	Complaint for Patent Infringement against Teradata Operations, Inc., filed in Realtime Data LLC d/b/a IXO v. Teradata Operations, Inc., Case No. 2:16-cv-02743 (C.D. Cal.), filed April 21, 2016; 31 pages.	
	NPL3	Defendant Oracle America, Inc.'s Answer to Realtime Data LLC's Complaint and Counterclaims, filed in Realtime Data LLC d/b/a IXO v. Oracle America, Inc., Case No. 6:16-cv-00088-RWS-JDL (E.D. Tex.), filed May 3, 2016; 22 pages.	
	NPL4	Defendants' Letter Requesting Permission to File a Motion for Partial Summary Judgment of Invalidity, filed in Realtime Data LLC d/b/a IXO v. Actian Corporation, et al., Case No. 6:15-cv-00463-RWS-JDL (E.D. Tex.) filed April 20, 2016; 6 pages.	
	NPL5	Plaintiff's Letter in Opposition to Moving Defendants' Letter Requesting Permission to File a Motion for Partial Summary Judgment, filed in Realtime Data LLC d/b/a IXO v. Actian Corporation, et al., Case No. 6:15-cv-00463-RWS-JDL (E.D. Tex.) filed May 9, 2016; 6 pages.	
	NPL6	Copy of Notice of Allowance for U.S. Pat. Appl. No. 14/727,309, mailed April 26, 2016; 7 pages.	
	NPL7	Copy of Notice of Allowance for U.S. Patent Appl. No. 14/733,565, mailed May 6, 2016; 6 pages.	
	NPL8	Petition for Inter Partes Review of U.S. Patent No. 7,415,530, filed in Dell Inc., et al. v. Realtime Data LLC d/b/a IXO, Case No. IPR2016-00878 (P.T.A.B.), filed April 22, 2016; 69 pages.	
	NPL9	Declaration of Charles D. Creusere, filed in Dell Inc., et al. v. Realtime Data LLC d/b/a IXO, Case No. IPR2016-00878 (P.T.A.B.), filed April 22, 2016; 124 pages.	
	NPL10	SOBH, et al., "A Comparison of Compressed and Uncompressed Transmission Modes," University of Pennsylvania Department of Computer and Information Science Technical Report No. MS-CIS-91-41, May 1991; 15 pages.	

Examiner Signature	/Tsfaldet Bocure/	Date Considered	05/29/2016
-----------------------	-------------------	--------------------	------------

\*EXAMINER: Initial if reference considered, whether or not citation is in conformance with MPEP 609. Draw line through citation if not in conformance and not considered. Include copy of this form with next communication to applicant.

<sup>1</sup> Applicant's unique citation designation number (optional). <sup>2</sup> Applicant is to place a check mark here if English language Translation is attached.

ALL REFERENCES CONSIDERED EXCEPT WHERE LINED THROUGH. /T.B./

Substitute for form 1449/PTO		<b>Complete if Known</b>	
<b>SIXTH SUPPLEMENTAL INFORMATION DISCLOSURE STATEMENT BY APPLICANT</b> <i>(Use as many sheets as necessary)</i>		Application Number	14/876,276
		Filing Date	October 6, 2015
		First Named Inventor	James J. FALLON
		Art Unit	2634
		Examiner Name	BOCURE, TEFALDET
		Attorney Docket Number	3421.005000C
Sheet	2	of	2

NON PATENT LITERATURE DOCUMENTS			
Examiner Initials*	Cite No. <sup>1</sup>	Include name of the author (in CAPITAL LETTERS), title of the article (when appropriate), title of the item (book, magazine, journal, serial, symposium, catalog, etc.), date, page(s), volume number, publisher, city and/or country where published	T <sup>2</sup>
	NPL11	9704 Data Compression Coprocessor Data Sheet, Stac Electronics, September, 1991; 56 pages.	
	NPL12	Petition for Inter Partes Review of U.S. Patent No. 8,643,513, filed in Riverbed Technology, Inc., et al. v. Realtime Data, LLC, Case No. IPR2016-00978 (P.T.A.B.), filed April 29, 2016; 65 pages.	
	NPL13	Declaration of Charles D. Creusere, Ph.D. Under 37 C.F.R. § 1.68, filed in Riverbed Technology, Inc., et al. v. Realtime Data, LLC, Case No. IPR2016-00978 (P.T.A.B.), filed April 29, 2016; 139 pages.	
	NPL14	Petition for Inter Partes Review of U.S. Patent No. 9,116,908, filed in Dell Inc. al. v. Realtime Data, LLC, Case No. IPR2016-01002 (P.T.A.B.), filed May 5, 2016; 68 pages.	
	NPL15	Declaration of Charles D. Creusere, Ph.D., filed in Dell Inc. al. v. Realtime Data, LLC, Case No. IPR2016-01002 (P.T.A.B.), filed May 5, 2016; 105 pages.	
	NPL16	Petition for Inter Partes Review of U.S. Patent No. 7,415,530, filed in Dell Inc. al. v. Realtime Data, LLC, Case No. IPR2016-00972 (P.T.A.B.), filed April 29, 2016; 69 pages.	
	NPL17	Declaration of Charles D. Creusere, Ph.D., filed in Dell Inc. al. v. Realtime Data, LLC, Case No. IPR2016-00972 (P.T.A.B.), filed April 29, 2016; 124 pages.	
	NPL18	Petition for Inter Partes Review of U.S. Patent No. 7,378,992, filed in Riverbed Technology, Inc. v. Realtime Data, LLC, Case No. IPR2016-00980 (P.T.A.B.), filed April 29, 2016; 57 pages.	
	NPL19	Declaration of Charles D. Creusere, Ph.D., filed in Dell Inc. al. v. Realtime Data, LLC, Case No. IPR2016-00980 (P.T.A.B.), filed April 29, 2016; 105 pages.	
	NPL20	Court Docket History for Realtime Data LLC d/b/a IXO v. Teradata Operations, Inc., Case No. 2:16-cv-02743 (C.D. Cal), downloaded April 26, 2016; 2 pages.	

2810041\_1.DOCX


Examiner Signature	/Tefaldet Bocure/	Date Considered	05/29/2016
-----------------------	-------------------	--------------------	------------

\*EXAMINER: Initial if reference considered, whether or not citation is in conformance with MPEP 609. Draw line through citation if not in conformance and not considered. Include copy of this form with next communication to applicant.

<sup>1</sup> Applicant's unique citation designation number (optional). <sup>2</sup> Applicant is to place a check mark here if English language Translation is attached.

**ALL REFERENCES CONSIDERED EXCEPT WHERE LINED THROUGH. /T.B./**




<b>Issue Classification</b> 	<b>Application/Control No.</b> 14876276	<b>Applicant(s)/Patent Under Reexamination</b> FALLON ET AL.	
	<b>Examiner</b> TESFALDET BOCURE	<b>Art Unit</b> 2634	

CPC						
Symbol					Type	Version
H04N	19			103	F	2014-11-01
H04N	19			164	I	2014-11-01
H04N	19			176	I	2014-11-01
H03M	7			30	I	2013-01-01
H03M	7			3084	I	2013-01-01
H03M	7			6094	I	2013-01-01

CPC Combination Sets				
Symbol	Type	Set	Ranking	Version


NONE		<b>Total Claims Allowed:</b>	
(Assistant Examiner)	(Date)	30	
/TESFALDET BOCURE/ Primary Examiner.Art Unit 2634	05/29/2016	O.G. Print Claim(s)	O.G. Print Figure
(Primary Examiner)	(Date)	1	1



<b>Issue Classification</b> 	<b>Application/Control No.</b> 14876276	<b>Applicant(s)/Patent Under Reexamination</b> FALLON ET AL.
	<b>Examiner</b> TESFALDET BOCURE	<b>Art Unit</b> 2634

<input checked="" type="checkbox"/> <b>Claims renumbered in the same order as presented by applicant</b> <input type="checkbox"/> <b>CPA</b> <input type="checkbox"/> <b>T.D.</b> <input type="checkbox"/> <b>R.1.47</b>															
Final	Original	Final	Original	Final	Original	Final	Original	Final	Original	Final	Original	Final	Original	Final	Original
1	1	17	17												
2	2	18	18												
3	3	19	19												
4	4	20	20												
5	5	21	21												
6	6	22	22												
7	7	23	23												
8	8	24	24												
9	9	25	25												
10	10	26	26												
11	11	27	27												
12	12	28	28												
13	13	29	29												
14	14	30	30												
15	15														
16	16														


NONE		<b>Total Claims Allowed:</b>	
(Assistant Examiner)		30	
/TESFALDET BOCURE/		(Date)	
Primary Examiner.Art Unit 2634		05/29/2016	
(Primary Examiner)		O.G. Print Claim(s)	O.G. Print Figure
		1	1

<b>Index of Claims</b>  	<b>Application/Control No.</b> 14876276	<b>Applicant(s)/Patent Under Reexamination</b> FALLON ET AL.
	<b>Examiner</b> TESFALDET BOCURE	<b>Art Unit</b> 2634

✓	<b>Rejected</b>	-	<b>Cancelled</b>	N	<b>Non-Elected</b>	A	<b>Appeal</b>
=	<b>Allowed</b>	÷	<b>Restricted</b>	I	<b>Interference</b>	O	<b>Objected</b>

Claims renumbered in the same order as presented by applicant
  CPA
  T.D.
  R.1.47

CLAIM		DATE							
Final	Original	01/23/2016	04/18/2016	05/29/2016					
1	1	✓	=	=					
2	2	✓	=	=					
3	3	✓	=	=					
4	4	✓	=	=					
5	5	✓	=	=					
6	6	✓	=	=					
7	7	✓	=	=					
8	8	✓	=	=					
9	9	✓	=	=					
10	10	✓	=	=					
11	11	✓	=	=					
12	12	✓	=	=					
13	13	✓	=	=					
14	14	✓	=	=					
15	15	✓	=	=					
16	16	✓	=	=					
17	17	✓	=	=					
18	18	✓	=	=					
19	19	✓	=	=					
20	20	✓	=	=					
21	21	✓	=	=					
22	22	✓	=	=					
23	23	✓	=	=					
24	24	✓	=	=					
25	25	✓	=	=					
26	26	✓	=	=					
27	27	✓	=	=					
28	28	✓	=	=					
29	29	✓	=	=					
30	30	✓	=	=					

<b>Search Notes</b>  	<b>Application/Control No.</b>  14876276	<b>Applicant(s)/Patent Under Reexamination</b>  FALLON ET AL.
	<b>Examiner</b>  TESFALDET BOCURE	<b>Art Unit</b>  2634

<b>CPC- SEARCHED</b>		
Symbol	Date	Examiner
((H03M7/30))   ((H03M7/3084))   ((H03M7/6094))   ((G06F15/7867))   ((G06T1/60))   ((H04N19/136).CPC.)	01/22/2016	TB
((H03M7/30))   ((H03M7/3059))   ((H03M7/3093))   ((H04L69/04))   ((H04N19/152))   ((H04N9/8042).CPC.)	01/22/2016	TB
( ( H03M7/30   H03M7/3059   H03M7/3084   H03M7/6094   H03M7/3088   H03M7/6023   H03M7/6064   H04N19/152   G11B20/00007 ).CPC.)	01/23/2016	TB
(H03M7/30 H03M7/3084 H03M7/6094 H04N19/164 H04N19/176 H04N19/103).CPC.	04/17/2016	TB
CPC Updated	04/18/2016	TB
CPC Updated	05/29/2016	TB

<b>CPC COMBINATION SETS - SEARCHED</b>		
Symbol	Date	Examiner

<b>US CLASSIFICATION SEARCHED</b>			
Class	Subclass	Date	Examiner
375	240, 240.01, 240.02	01/22/2016	TB
341	50, 51, 126	01/22/2016	TB
375, 370, 348, 341, 711, 701, 381	Search ALL (\$8.ccls.)	01/22/2016	TB
375, 370, 348, 341, 711, 701, 381	Search Updated ALL	01/23/2016	TB
375, 370, 348, 341, 711, 701, 381	Search Updated ALL	04/17/2016 & 04/18/2016	TB
375, 370, 348, 341, 711, 701, 381	Search Updated ALL	05/29/2016	TB

	/TESFALDET BOCURE/ Primary Examiner.Art Unit 2634
--	--

### SEARCH NOTES

Search Notes	Date	Examiner
WEST and Inventor's Name Searched	01/22/2016	TB
See Realted parent application 14/733,565 for further presecution History	01/22/2016	TB
WEST Search Updated	01/23/2016	TB
WEST Search Updated	04/17/2016	TB
WEST Search Updated	04/18/2016	TB
WEST Search Updated	05/29/2016	TB

### INTERFERENCE SEARCH

US Class/ CPC Symbol	US Subclass / CPC Group	Date	Examiner
375	240, 240.1	04/18/2016	TB
CPC	(H03M7/30 H03M7/3084 H03M7/6094 H04N19/164 H04N19/176 H04N19/103).CPC.	04/18/2016	TB
375	240, 240.1	05/29/2016	TB
CPC	(H03M7/30 H03M7/3084 H03M7/6094 H04N19/164 H04N19/176 H04N19/103).CPC.	05/29/2016	TB

/TESFALDET BOCURE/  
Primary Examiner.Art Unit 2634

Under the Paperwork Reduction Act of 1995, no persons are required to respond to a collection of information unless it contains a valid OMB control number.

**Request  
 for  
 Continued Examination (RCE)  
 Transmittal**

Address to:  
 Mail Stop RCE  
 Commissioner for Patents  
 P.O. Box 1450  
 Alexandria, VA 22313-1450

Application Number	14/876,276
Filing Date	October 6, 2015
First Named Inventor	James J. FALLON
Art Unit	2634
Examiner Name	3403
Attorney Docket Number	3421.005000C

**This is a Request for Continued Examination (RCE) under 37 CFR 1.114 of the above-identified application.**  
 Request for Continued Examination (RCE) practice under 37 CFR 1.114 does not apply to any utility or plant application filed prior to June 8, 1995, or to any design application. See Instruction Sheet for RCEs (not to be submitted to the USPTO) on page 2.

1. **Submission required under 37 CFR 1.114.** Note: If the RCE is proper, any previously filed unentered amendments and amendments enclosed with the RCE will be entered in the order in which they were filed unless applicant instructs otherwise. If applicant does not wish to have any previously filed unentered amendment(s) entered, applicant must request non-entry of such amendment(s).

- a.  Previously submitted. If a final Office action is outstanding, any amendments filed after the final Office action may be considered as a submission even if this box is not checked.
  - i.  Consider the arguments in the Appeal Brief or Reply Brief previously filed on \_\_\_\_\_
  - ii.  Other \_\_\_\_\_
- b.  Enclosed
  - i.  Amendment/Reply
  - ii.  Affidavit(s)/ Declaration(s)
  - iii.  Information Disclosure Statement (IDS)
  - iv.  Other \_\_\_\_\_

2. **Miscellaneous**

- a.  Suspension of action on the above-identified application is requested under 37 CFR 1.103(c) for a period of \_\_\_\_\_ months. (Period of suspension shall not exceed 3 months; Fee under 37 CFR 1.17(i) required)
- b.  Other \_\_\_\_\_

3. **Fees**

- The RCE fee under 37 CFR 1.17(e) is required by 37 CFR 1.114 when the RCE is filed.
- The Director is hereby authorized to charge the following fees, any underpayment of fees, or credit any overpayments, to Deposit Account No. 19-0036
  - a. 
    - i.  RCE fee required under 37 CFR 1.17(e)
    - ii.  Extension of time fee (37 CFR 1.136 and 1.17)
    - iii.  Other \_\_\_\_\_
  - b.  Check in the amount of \$ \_\_\_\_\_ enclosed
  - c.  Payment by credit card (Form PTO-2038 enclosed)

**WARNING: Information on this form may become public. Credit card information should not be included on this form. Provide credit card information and authorization on PTO-2038.**

**SIGNATURE OF APPLICANT, ATTORNEY, OR AGENT REQUIRED**

Signature		Date	July 27, 2016
Name (Print/Type)	Michael V. Messinger	Registration No.	37,575

**CERTIFICATE OF MAILING OR TRANSMISSION**

I hereby certify that this correspondence is being deposited with the United States Postal Service with sufficient postage as first class mail in an envelope addressed to: Mail Stop RCE, Commissioner for Patents, P. O. Box 1450, Alexandria, VA 22313-1450 or facsimile transmitted to the U.S. Patent and Trademark Office on the date shown below.

Signature		Date	
Name (Print/Type)			

This collection of information is required by 37 CFR 1.114. The information is required to obtain or retain a benefit by the public which is to file (and by the USPTO to process) an application. Confidentiality is governed by 35 U.S.C. 122 and 37 CFR 1.11 and 1.14. This collection is estimated to take 12 minutes to complete, including gathering, preparing, and submitting the completed application form to the USPTO. Time will vary depending upon the individual case. Any comments on the amount of time you require to complete this form and/or suggestions for reducing this burden, should be sent to the Chief Information Officer, U.S. Patent and Trademark Office, U.S. Department of Commerce, P.O. Box 1450, Alexandria, VA 22313-1450. DO NOT SEND FEES OR COMPLETED FORMS TO THIS ADDRESS. SEND TO: Mail Stop RCE, Commissioner for Patents, P.O. Box 1450, Alexandria, VA 22313-1450.

If you need assistance in completing the form, call 1-800-PTO-9199 and select option 2.

2842694

IN THE UNITED STATES PATENT AND TRADEMARK OFFICE

Inventors: FALLON *et al.*

Confirmation No.: 3403

Applicant: Realtime Data LLC

Art Unit: 2634

Application No.: 14/876,276

Examiner: 3403

Filing Date: October 6, 2015

Atty. Docket: 3421.005000C

Title: **Video Data Compression Systems**

**Seventh Supplemental Information Disclosure Statement**

*Mail Stop RCE*

Commissioner for Patents  
PO Box 1450  
Alexandria, VA 22313-1450

Commissioner:

Notice of Prior and Concurrent Proceedings

Applicant hereby calls to the attention of the Patent and Trademark Office the following reexamination proceedings involving patents that are commonly-assigned with the patent in the above-identified patent application:

<b>Proceeding</b>	<b>Status</b>
Inter Partes Reexamination of U.S. Patent No. 6,604,158 (Control No. 95/000,486)	Inter Partes Reexamination Certificate issued 10/10/2012
Inter Partes Reexamination of U.S. Patent No. 7,321,937 (Control No. 95/000,466)	Inter Partes Reexamination Certificate issued 05/15/2012
Inter Partes Reexamination of U.S. Patent No. 6,604,158 (Control No. 95/000,453)	Terminated
Ex Parte Reexamination of U.S. Patent No. 6,601,104 (Control No. 90/009,428)	Ex Parte Reexamination Certificate issued 02/28/2012
Inter Partes Reexamination of U.S. Patent No. 7,378,992 (Control No. 95/000,478)	Inter Partes Reexamination Certificate issued 10/04/2012
Inter Partes Reexamination of U.S. Patent No. 6,624,761 (Control No. 95/000,464)	Inter Partes Reexamination Certificate issued 06/12/2012
Inter Partes Reexamination of U.S. Patent No. 7,161,506 (Control No. 95/000,479)	Inter Partes Reexamination Certificate issued 05/22/2012



<b>Proceeding</b>	<b>Status</b>
Inter Partes Reexamination of U.S. Patent No. 7,714,747 (Control No. 95/001,517)	Appeal to the Court of Appeals for the Federal Circuit dismissed 6/4/2015
Inter Partes Reexamination of U.S. Patent No. 7,417,568 (Control No. 95/001,533)	Inter Partes Reexamination Certificate issued 07/22/2016
Inter Partes Reexamination of U.S. Patent No. 7,777,651 (Control No. 95/001,581)	Inter Partes Reexamination Certificate issued 07/08/2016
Inter Partes Reexamination of U.S. Patent No. 7,400,274 (Control No. 95/001,544)	Notice of Intent to Issue Inter Partes Reexamination Certificate mailed 7/15/2016

Applicant hereby calls to the attention of the Patent and Trademark Office the following reexamination proceedings filed by Celco Partnership d/b/a Verizon Wireless, involving patents that are commonly-assigned with the patent in the above-identified patent application:

<b>Proceeding</b>	<b>Status</b>
Inter Partes Reexamination of U.S. Patent No. 7,321,937 (Control No. 95/001,922)	Inter Partes Reexamination Certificate issued 12/05/2013
Inter Partes Reexamination of U.S. Patent No. 6,604,158 (Control No. 95/001,923)	Inter Partes Reexamination Certificate issued 04/17/2015
Inter Partes Reexamination of U.S. Patent No. 7,352,300 (Control No. 95/001,924)	Inter Partes Reexamination Certificate issued 08/04/2014
Inter Partes Reexamination of U.S. Patent No. 7,395,345 (Control No. 95/001,925)	Inter Partes Reexamination Certificate issued 11/03/2014
Inter Partes Reexamination of U.S. Patent No. 7,161,506 (Control No. 95/001,926)	Inter Partes Reexamination Certificate issued 01/08/2014
Inter Partes Reexamination of U.S. Patent No. 7,415,530 (Control No. 95/001,927)	Inter Partes Reexamination Certificate issued 08/16/2013
Inter Partes Reexamination of U.S. Patent No. 7,378,992 (Control No. 95/001,928)	Inter Partes Reexamination Certificate issued 01/08/2014

Applicant invites the Examiner to review the Requests for Reexamination, issued Office Actions, replies, and any other papers in the above-identified reexamination proceedings. If the Examiner is unable to obtain copies of papers in any reexamination proceeding, copies can be

Atty. Dkt. No. 3421.005000C

provided to the Examiner upon request. Those documents which may be material that are not already of record in this patent application are listed on the accompanying Form PTO/SB/08 as documents NPL40-NPL44.

Applicant hereby calls to the attention of the Patent and Trademark Office the following *inter partes* review proceedings involving patents that are commonly-assigned with the patent in the above-identified patent application:

Proceeding	Patent	Status
<i>Oracle America, Inc. v. Realtime Data LLC</i> , IPR2016-00373	7,378,992	Institution Decision mailed June 27, 2016
<i>Oracle America, Inc. v. Realtime Data LLC</i> , IPR2016-00374	8,643,513	Institution Decision mailed June 27, 2016
<i>Oracle America, Inc. v. Realtime Data LLC</i> , IPR2016-00375	7,415,530	Institution denied July 1, 2016
<i>Oracle America, Inc. v. Realtime Data LLC</i> , IPR2016-00376	7,415,530	Institution denied July 1, 2016
<i>Oracle America, Inc. v. Realtime Data LLC</i> , IPR2016-00377	9,116,908	Institution denied July 1, 2016
<i>SAP America Inc., et al. v. Realtime Data LLC d/b/a IXO</i> , IPR2016-00783	6,597,812	Patent Owner Preliminary Response filed June 15, 2016
<i>Dell Inc., et al. v. Realtime Data LLC</i> , IPR2016-00878	7,415,530	Dismissed June 21, 2016
<i>Dell Inc., et al. v. Realtime Data LLC</i> , IPR2016-00972	7,415,530	Petition filed April 29, 2016
<i>Riverbed Technology, Inc. et al. v. Realtime Data LLC</i> , IPR2016-00978	8,643,513	Petition filed April 29, 2016
<i>Riverbed Technology, Inc. et al. v. Realtime Data LLC</i> , IPR2016-00980	7,378,992	Petition filed April 29, 2016
<i>Dell Inc., et al. v. Realtime Data LLC</i> , IPR2016-01002	9,116,908	Petition filed May 5, 2016
<i>Apple Inc. v. Realtime Data LLC</i> , IPR2016-01365	7,181,608	Petition filed July 8, 2016
<i>Apple Inc. v. Realtime Data LLC</i> , IPR2016-01366	8,090,936	Petition filed July 8, 2016

Applicant invites the Examiner to review the petitions for *inter partes* review and any other papers in the above-identified *inter partes* review proceedings. If the Examiner is unable to obtain copies of papers in any *inter partes* review proceeding, copies can be provided to the Examiner upon request. Those documents which may be material that are not already of record in this patent application are listed on the accompanying Form PTO/SB/08 as documents **US2**, **US4-US5** and **NPL45-NPL61**.

Notice of Related Litigation

Applicant notifies the Patent and Trademark Office of the following litigation involving U.S. Patents commonly-owned with the current patent application, the subject matter of which may be related to the present patent application:

No.	Case	Status
1	<i>Realtime Data LLC d/b/a IXO v. Packeteer, Inc. et al.</i> , No. 6:08-cv-00144-LED (E.D. Texas)	Dismissed

Applicant also notifies the Patent and Trademark Office of the following additional litigation involving U.S. Patents commonly-owned with the current patent application, the subject matter of which may be related to the present patent application:

No.	Case	Status
2	<i>Realtime Data LLC d/b/a IXO v. Thomson Reuters Corporation et al.</i> No. 1:11-cv-06698-RJH (S.D. New York) (transferred from E.D. Texas; 6:09-cv-00333-LED)	Case Terminated 11/9/2012; Opinion of the Court of Appeals for the Federal Circuit received 01/27/2014

3	<i>Realtime Data LLC d/b/a IXO v. Morgan Stanley et al.</i> , No. 1:11-cv-06696-RJH (S.D. New York) (transferred from E.D. Texas; 6:09-cv-00326-LED)	Case Terminated 11/9/2012; Opinion of the Court of Appeals for the Federal Circuit received 01/27/2014
4	<i>Realtime Data LLC d/b/a IXO v. CME Group Inc., et al.</i> , No. 1:11-cv-06697-RJH (S.D. New York) (transferred from E.D. Texas; No. 6:09-cv-00327-LED)	Case Terminated 11/9/2012; Opinion of the Court of Appeals for the Federal Circuit received 01/27/2014
5	<i>Chicago Board Options Exchange, Inc., v. Realtime Data LLC d/b/a IXO</i> , No. 09-cv-4486 (N.D. Ill.)	Dismissed
6	<i>Thomson Reuters Corporation v. Realtime Data, LLC d/b/a IXO</i> , No. 1:09-cv-07868-RMB (S.D.N.Y)	Consolidated with Case No. 2
7	<i>Realtime Data, LLC d/b/a IXO v. CME Group Inc., et al. (II)</i> , No. 6:10-cv-246 (E.D. Texas)	Consolidated with Case No. 4
8	<i>Realtime Data LLC d/b/a IXO v. Thomson Reuters Corporation et al. (II)</i> , No. 6:10-cv-247 (E.D. Texas)	Consolidated with Case No. 2
9	<i>Realtime Data, LLC d/b/a IXO v. Morgan Stanley, et al. (II)</i> , No. 6:10-cv-248 (E.D. Texas)	Consolidated with Case No. 3
10	<i>Realtime Data, LLC d/b/a IXO v. MetroPCS Texas, LLC et al.</i> , No. 6:10-cv-00493 (E.D. Texas)	Appeal Terminated
11	<i>Realtime Data, LLC d/b/a IXO v. Microsoft Corporation, et al.</i> , No. 4:14-cv-00827 (E.D. Texas)	Dismissed May 1, 2015
12	<i>Realtime Data LLC d/b/a IXO v. Actian Corporation, et al.</i> , No. 6:15-cv-00463 (E.D. Texas)	Order Granting Motion to Supplement Claim Construction Record issued July 22, 2016
13	<i>Realtime Data LLC d/b/a IXO v. Dropbox, Inc.</i> , No. 6:15-cv-00465 (E.D. Texas)	Dismissed February 22, 2016
14	<i>Realtime Data LLC d/b/a IXO v. Echostar Corporation, et al.</i> , No. 6:15-cv-00466 (E.D. Texas)	Consolidated with Case No. 12
15	<i>Realtime Data LLC d/b/a IXO v. Riverbed Technology, Inc., et al.</i> , No. 6:15-cv-00468 (E.D. Texas)	Consolidated with Case No. 12
16	<i>Realtime Data LLC d/b/a IXO v. BMC Software, Inc.</i> , No. 6:15-cv-00464 (E.D. Texas)	Terminated October 5, 2015
17	<i>Realtime Data LLC d/b/a IXO v. Oracle America, Inc., et al.</i> , No. 6:15-cv-00467 (E.D. Texas)	Consolidated with Case No. 22

18	<i>Realtime Data LLC d/b/a IXO v. SAP America, Inc., et al.</i> , No. 6:15-cv-00469 (E.D. Texas)	Consolidated with Case No. 12; Joint Stipulation of Dismissal filed July 26, 2016
19	<i>Realtime Data, LLC d/b/a IXO v. Teradata Corporation, et al.</i> , No. 3:16-cv-01836 (N.D. Cal.) (formerly no. 6:15-cv-00470 (E.D. Texas))	Case dismissed May 18, 2016
20	<i>Realtime Data LLC d/b/a IXO v. Apple Inc.</i> , No. 3:16-cv-02595 (N.D. Cal.) (formerly Case No. 6:15-cv-00885 (E.D. Texas))	Transferred to the Northern District of California, May 11, 2016
21	<i>Realtime Data LLC d/b/a IXO v. Hewlett Packard Enterprise Co., et al.</i> , No. 6:16-cv-00086 (E.D. Texas)	Answers to Defendants' Counterclaims filed June 23, 2016
22	<i>Realtime Data LLC d/b/a IXO v. Oracle America, Inc.</i> , No. 6:16-cv-00088 (E.D. Texas)	Plaintiff's Opening Claim Construction Brief filed July 25, 2016
23	<i>Realtime Data LLC d/b/a IXO v. Savvis Party Communications Corporation, et al.</i> , No. 6:16-cv-00087 (E.D. Texas)	Answer to Defendant's Counter-Claims filed July 8, 2016
24	<i>Realtime Data LLC d/b/a IXO v. Dell, Inc., et al.</i> , No. 6:16-cv-00089 (E.D. Texas)	Answer to Amended Complaint filed June 23, 2016
25	<i>Realtime Data LLC d/b/a IXO v. Teradata Operations, Inc.</i> , No. 2:16-cv-02743 (C.D. Cal.)	Amended Complaint filed May 17, 2016
26	<i>Realtime Data LLC d/b/a IXO v. Rackspace US, Inc., et al.</i> , No. 6:16-cv-00961 (E.D. Texas)	Complaint filed June 29, 2016
27	<i>Realtime Data LLC d/b/a IXO v. Fujitsu America, Inc. et al.</i> , No. 6:16-cv-01035 (E.D. Texas)	Complaint filed July 21, 2016
28	<i>Realtime Data LLC d/b/a IXO v. Vembu Technologies, Inc.</i> , No. 6:16-cv-01037 (E.D. Texas)	Complaint filed July 22, 2016

Court dockets for pending litigations are submitted herewith as documents **NPL62-NPL64**.

Atty. Dkt. No. 3421.005000C

Information Disclosure Statement

Listed on accompanying IDS Forms PTO/SB/08a equivalent and PTO/SB/08b equivalent are documents that may be considered material to the patentability of this application as defined in 37 C.F.R. §1.56, and in compliance with the duty of disclosure requirements of 37 C.F.R. §§ 1.97 and 1.98.

Applicant has listed publication dates on the attached IDS Forms based on information presently available to the undersigned. However, the listed publication dates should not be construed as an admission that the information was actually published on the date indicated.

Applicant reserves the right to establish the patentability of the claimed invention over any of the information provided herewith, and/or to prove that this information may not be prior art, and/or to prove that this information may not be enabling for the teachings purportedly offered.

This statement should not be construed as a representation that a search has been made, or that information more material to the examination of the present patent application does not exist. The Examiner is specifically requested not to rely solely on the material submitted herewith.

Filing under 37 C.F.R. § 1.97(b). This Information Disclosure Statement is being filed before the mailing of a first Office Action after the filing of a request for continued examination under 37 C.F.R. § 1.114. No statement or fee is required.

Copies of documents **NPL1-NPL64** are submitted. However, in accordance with 37 C.F.R. § 1.98(a)(2)(ii), no copies of the U.S. patents and patent application publication cited as documents **US1-US7** on the attached IDS Forms are submitted.

Applicant submits herewith Office Actions from the following co-pending U.S. Patent Application Nos.:

Document **NPL38** is a copy of a Non-Final Office Action mailed May 17, 2016 in the prosecution of co-pending, commonly-assigned U.S. Patent Application No. 14/844,973.

Document **NPL39** is a copy of a Non-Final Office Action mailed June 7, 2016 in the prosecution of co-pending, commonly-assigned U.S. Patent Application No. 14/727,309.

The identification of these Office Actions is not to be construed as a waiver of secrecy as to those applications now or upon issuance of the present application as a patent. The Examiner is respectfully requested to consider the cited applications and the art cited therein during examination.

It is expected that the examiner will review the prosecution and cited art in the parent application nos. 14/733,565, filed June 8, 2015 (now pending); 14/577,286, filed December 19, 2014 (now abandoned); 14/134,933, filed December 19, 2013 (now U.S. Patent No. 8,929,442); 14/033,245, filed September 20, 2013 (now U.S. Patent No. 8,934,535); 13/154,239, filed June 6, 2011 (now U.S. Patent No. 8,553,759); 12/123,081, filed May 19, 2008 (now U.S. Patent No. 8,073,047); and 10/076,013, filed February 13, 2002 (now U.S. Patent No. 7,386,046), in accordance with MPEP 2001.06(b), and indicate in the next communication from the office that the art cited in the earlier prosecution history has been reviewed in connection with the present application.

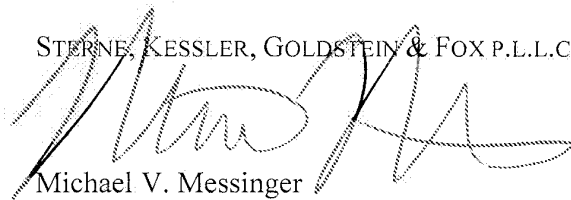
Atty. Dkt. No. 3421.005000C

It is respectfully requested that the Examiner initial and return a copy of the enclosed IDS Forms, and indicate in the official file wrapper of this patent application that the documents have been considered.

The U.S. Patent and Trademark Office is hereby authorized to charge any fee deficiency, or credit any overpayment, to our Deposit Account No. 19-0036.

Respectfully submitted,

STERNE, KESSLER, GOLDSTEIN & FOX P.L.L.C.



Michael V. Messinger  
Attorney for Applicant  
Registration No. 37,575

Date: July 27, 2016

1100 New York Avenue, N.W.  
Washington, D.C. 20005-3934  
(202) 371-2600

2842685\_1.DOCX





Substitute for form 1449/PTO		<i>Complete if Known</i>	
<b>SEVENTH SUPPLEMENTAL INFORMATION DISCLOSURE STATEMENT BY APPLICANT</b> <i>(Use as many sheets as necessary)</i>		Application Number	14/876,276
		Filing Date	October 6, 2015
		First Named Inventor	James J. FALLON
		Art Unit	2634
		Examiner Name	3403
Sheet	1	of	7
		Attorney Docket Number	3421.005000C

NON PATENT LITERATURE DOCUMENTS			
Examiner Initials*	Cite No. <sup>1</sup>	Include name of the author (in CAPITAL LETTERS), title of the article (when appropriate), title of the item (book, magazine, journal, serial, symposium, catalog, etc.), date, page(s), volume-issue number(s), publisher, city and/or country where published	T <sup>2</sup>
	NPL1	Amended Complaint for Patent Infringement Against Teradata Operations, Inc., filed in Realtime Data LLC d/b/a IXO v. Teradata Operations, Inc., Case No. 2:16-cv-02743-AG-FFM (C.D. Cal.), filed May 17, 2016; 58 pages.	
	NPL2	Defendants Hewlett Packard Enterprise Co. and HP Enterprise Services, LLC's Answer to Plaintiff's Complaint for Patent Infringement and Counterclaims, filed in Realtime Data LLC d/b/a IXO v. Hewlett Packard Enterprise Co., et al., Case No. 6:16-cv-00086-RWS-JDL (E.D. Tex.), filed May 20, 2016; 20 pages.	
	NPL3	Plaintiff Realtime Data LLC's Opening Claim Construction Brief, filed in Realtime Data LLC d/b/a IXO v. Actian Corporation, et al., Case No. 6:15-cv-463-RWS-JDL (E.D. Texas), filed May 23, 2016; 37 pages.	
	NPL4	The Agreed and Disputed Constructions, as of May 23, 2016, Exhibit 12 to Plaintiff Realtime Data LLC's Opening Claim Construction Brief, filed in Realtime Data LLC d/b/a IXO v. Actian Corporation, et al., Case No. 6:15-cv-463-RWS-JDL (E.D. Texas), filed May 23, 2016; 4 pages.	
	NPL5	Plaintiff Realtime Data LLC's Expert Declaration of Dr. Kenneth Zeger, filed in Realtime Data LLC d/b/a IXO v. Actian Corporation, et al., Case No. 6:15-cv-463-RWS-JDL (E.D. Texas), filed May 23, 2016; 21 pages.	
	NPL6	Answer, Defenses, and Counterclaims to Plaintiff's Complaint for Patent Infringement, filed in Realtime Data LLC d/b/a IXO v. Hewlett Packard Enterprise Co., et al., Case No. 6:16-cv-00086 (E.D. Texas), filed June 3, 2016; 23 pages.	
	NPL7	Defendant Veritas Technologies LLC's Answer, Affirmative Defenses, and Counterclaims, filed in Realtime Data LLC d/b/a IXO v. Centurylink, Inc., et al., Case No. 6:16-cv-00087-RWS-JDL (E.D. Texas), filed June 6, 2016; 30 pages.	
	NPL8	Amended Complaint for Patent Infringement Against Dell Inc. and EMC Corporation, filed in Realtime Data LLC d/b/a IXO v. Dell Inc., et al., Case No. 6:16-cv-00089-RWS-JDL (E.D. Texas), filed June 9, 2016; 47 pages.	
	NPL9	Savvis Communications Corporations' Answer, Affirmative Defenses, and Counterclaims, filed in Realtime Data LLC d/b/a IXO v. Savvis Communications Corporation, et al., Case No. 6:16-cv-00087-RWS-JDL (E.D. Texas), filed June 13, 2016; 16 pages.	
	NPL10	Defendants' Responsive Claim Construction Brief, filed in Realtime Data LLC d/b/a IXO v. Actian Corporation, et al., Case No. 6:16-cv-00463-RWS-JDL (E.D. Texas), filed June 13, 2016; 39 pages.	

Examiner Signature		Date Considered	
--------------------	--	-----------------	--

\*EXAMINER: Initial if reference considered, whether or not citation is in conformance with MPEP 609. Draw line through citation if not in conformance and not considered. Include copy of this form with next communication to applicant.  
<sup>1</sup> Applicant's unique citation designation number (optional). <sup>2</sup> Applicant is to place a check mark here if English language Translation is attached.

Substitute for form 1449/PTO		<b>Complete if Known</b>	
<b>SEVENTH SUPPLEMENTAL INFORMATION DISCLOSURE STATEMENT BY APPLICANT</b> <i>(Use as many sheets as necessary)</i>		Application Number	14/876,276
		Filing Date	October 6, 2015
		First Named Inventor	James J. FALLON
		Art Unit	2634
		Examiner Name	3403
		Attorney Docket Number	3421.005000C
Sheet	2	of	7

**NON PATENT LITERATURE DOCUMENTS**

Examiner Initials*	Cite No. <sup>1</sup>	Include name of the author (in CAPITAL LETTERS), title of the article (when appropriate), title of the item (book, magazine, journal, serial, symposium, catalog, etc.), date, page(s), volume number, publisher, city and/or country where published	T <sup>2</sup>
	NPL11	Declaration of Dr. Charles D. Creusere in Support of Defendants' Motion for Partial Summary Judgment of Indefiniteness, filed in Realtime Data LLC d/b/a IXO v. Actian Corporation, et al., Case No. 6:16-cv-00463-RWS-JDL (E.D. Texas), filed June 13, 2016; 10 pages.	
	NPL12	Excerpt from Modern Dictionary of Electronics, Seventh Edition, Boston: Newnes, 1999, Exhibit 1 to Defendants' Responsive Claim Construction Brief, filed in Realtime Data LLC d/b/a IXO v. Actian Corporation, et al., Case No. 6:16-cv-00463-RWS-JDL (E.D. Texas), filed June 13, 2016; 5 pages.	
	NPL13	Motion for Partial Summary Judgment of Indefiniteness By Defendants Dell Inc., Echostar Corporation, Hughes Network Systems LLC, Hewlett Packard Enterprise Co., HP Enterprise Services, LLC, Riverbed Technology, Inc., SAP America Inc., and Sybase, Inc., filed in Realtime Data LLC d/b/a IXO v. Actian Corporation, et al., Case No. 6:16-cv-00463-RWS-JDL (E.D. Texas), filed June 13, 2016; 15 pages.	
	NPL14	U.S. Provisional Patent Application No. 60/136,561, filed May 28, 1999, Exhibit C to Motion for Partial Summary Judgment of Indefiniteness By Defendants Dell Inc., Echostar Corporation, Hughes Network Systems LLC, Hewlett Packard Enterprise Co., HP Enterprise Services, LLC, Riverbed Technology, Inc., SAP America Inc., and Sybase, Inc., filed in Realtime Data LLC d/b/a IXO v. Actian Corporation, et al., Case No. 6:16-cv-00463-RWS-JDL (E.D. Texas), filed June 13, 2016; 24 pages.	
	NPL15	Declaration of James A. Storer, Ph.D., Exhibit 5 to Defendants' Responsive Claim Construction Brief, filed in Realtime Data LLC d/b/a IXO v. Actian Corporation, et al., Case No. 6:16-cv-00463-RWS-JDL (E.D. Texas), filed June 13, 2016; 37 pages.	
	NPL16	Dell Inc.'s Answer, Defenses, and Counterclaims to Plaintiff's Amended Complaint, filed in Realtime Data LLC d/b/a IXO v. Dell Inc., et al., Case No. 6:16-cv-00089-RWS-JDL (E.D. Texas), filed June 23, 2016; 17 pages.	
	NPL17	Defendants' Motion for Leave to Supplement Their Invalidity Contentions, filed in Realtime Data LLC d/b/a IXO v. Actian Corporation, et al., Case No. 6:15-cv-00463-RWS-JDL (E.D. Texas), filed June 24, 2016; 12 pages.	
	NPL18	Invalidity Chart for U.S. Patent No. 7,415,530 based on U.S. Patent No. 5,247,646 ("Osterlund"), filed as Exhibit A to Defendants' Motion for Leave to Supplement Their Invalidity Contentions, filed in Realtime Data LLC d/b/a IXO v. Actian Corporation, et al., Case No. 6:15-cv-00463-RWS-JDL (E.D. Texas), filed June 24, 2016; 19 pages.	
	NPL19	Invalidity Chart for U.S. Patent No. 7,415,530 based on U.S. Patent No. 5,479,638 ("Assar"), filed as Exhibit B to Defendants' Motion for Leave to Supplement Their Invalidity Contentions, filed in Realtime Data LLC d/b/a IXO v. Actian Corporation, et al., Case No. 6:15-cv-00463-RWS-JDL (E.D. Texas), filed June 24, 2016; 5 pages.	
	NPL20	Invalidity Chart for U.S. Patent No. 7,415,530 based on U.S. Patent No. 5,771,354 ("Crawford"), filed as Exhibit C to Defendants' Motion for Leave to Supplement Their Invalidity Contentions, filed in Realtime Data LLC d/b/a IXO v. Actian Corporation, et al., Case No. 6:15-cv-00463-RWS-JDL (E.D. Texas), filed June 24, 2016; 20 pages.	

Examiner Signature		Date Considered	
--------------------	--	-----------------	--

\*EXAMINER: Initial if reference considered, whether or not citation is in conformance with MPEP 609. Draw line through citation if not in conformance and not considered. Include copy of this form with next communication to applicant.  
<sup>1</sup> Applicant's unique citation designation number (optional). <sup>2</sup> Applicant is to place a check mark here if English language translation is attached.

Substitute for form 1449/PTO		<b>Complete if Known</b>	
<b>SEVENTH SUPPLEMENTAL INFORMATION DISCLOSURE STATEMENT BY APPLICANT</b> <i>(Use as many sheets as necessary)</i>		Application Number	14/876,276
		Filing Date	October 6, 2015
		First Named Inventor	James J. FALLON
		Art Unit	2634
		Examiner Name	3403
		Attorney Docket Number	3421.005000C
Sheet	3	of	7

NON PATENT LITERATURE DOCUMENTS			
Examiner Initials*	Cite No. <sup>1</sup>	Include name of the author (in CAPITAL LETTERS), title of the article (when appropriate), title of the item (book, magazine, journal, serial, symposium, catalog, etc.), date, page(s), volume number, publisher, city and/or country where published	T <sup>2</sup>
	NPL21	Invalidity Chart for U.S. Patent No. 7,415,530 based on U.S. Patent No. 5,319,682 ("Clark"), filed as Exhibit D to Defendants' Motion for Leave to Supplement Their Invalidity Contentions, filed in Realtime Data LLC d/b/a IXO v. Actian Corporation, et al., Case No. 6:15-cv-00463-RWS-JDL (E.D. Texas), filed June 24, 2016; 20 pages.	
	NPL22	513 v. PCT Publication No. WO 00/46688 to Wang et al., filed as Exhibit E to Defendants' Motion for Leave to Supplement Their Invalidity Contentions, filed in Realtime Data LLC d/b/a IXO v. Actian Corporation, et al., Case No. 6:15-cv-00463-RWS-JDL (E.D. Texas), filed June 24, 2016; 53 pages.	
	NPL23	Invalidity Chart for U.S. Patent No. 9,116,908 Based on U.S. Patent No. 5,247,646 ("Osterlund"), filed as Exhibit F to Defendants' Motion for Leave to Supplement Their Invalidity Contentions, filed in Realtime Data LLC d/b/a IXO v. Actian Corporation, et al., Case No. 6:15-cv-00463-RWS-JDL (E.D. Texas), filed June 24, 2016; 16 pages.	
	NPL24	Defendant Dell Inc.'s Preliminary Election of Prior Art, filed as Exhibit M to Defendants' Motion for Leave to Supplement Their Invalidity Contentions, filed in Realtime Data LLC d/b/a IXO v. Actian Corporation, et al., Case No. 6:15-cv-00463-RWS-JDL (E.D. Texas), filed June 24, 2016; 20 pages.	
	NPL25	Plaintiff Realtime Data LLC's Reply Claim Construction Brief, filed in Realtime Data LLC d/b/a IXO v. Actian Corporation, et al., Case No. 6:15-cv-00463-RWS-JDL (E.D. Texas), filed June 27, 2016; 15 pages.	
	NPL26	Plaintiff Realtime Data LLC's Response to Moving Defendants' Motion for Partial Summary Judgment of Indefiniteness, filed in Realtime Data LLC d/b/a IXO v. Actian Corporation, et al., Case No. 6:15-cv-00463-RWS-JDL (E.D. Texas), filed June 27, 2016; 20 pages.	
	NPL27	Moving Defendants' Reply Brief in Support of Their Motion for Partial Summary Judgment of Indefiniteness, filed in Realtime Data LLC d/b/a IXO v. Actian Corporation, et al., Case No. 6:15-cv-00463-RWS-JDL (E.D. Texas), filed June 30, 2016; 9 pages.	
	NPL28	Joint Claim Construction Chart - Exhibit A, filed in Realtime Data LLC d/b/a IXO v. Actian Corporation, et al., Case No. 6:15-cv-00463-RWS-JDL (E.D. Texas), filed June 30, 2016; 3 pages.	
	NPL29	Joint Claim Construction Chart - Exhibit B, filed in Realtime Data LLC d/b/a IXO v. Actian Corporation, et al., Case No. 6:15-cv-00463-RWS-JDL (E.D. Texas), filed June 30, 2016; 18 pages.	
	NPL30	Plaintiff's Notice of Supplemental Facts, filed in Realtime Data LLC d/b/a IXO v. Actian Corporation, et al., Case No. 6:15-cv-00463-RWS-JDL (E.D. Texas), filed July 5, 2016; 3 pages.	
Examiner Signature		Date Considered	

\*EXAMINER: Initial if reference considered, whether or not citation is in conformance with MPEP 609. Draw line through citation if not in conformance and not considered. Include copy of this form with next communication to applicant.

<sup>1</sup> Applicant's unique citation designation number (optional). <sup>2</sup> Applicant is to place a check mark here if English language Translation is attached.

Substitute for form 1449/PTO				<b>Complete if Known</b>	
<b>SEVENTH SUPPLEMENTAL INFORMATION DISCLOSURE STATEMENT BY APPLICANT</b> <i>(Use as many sheets as necessary)</i>				Application Number	14/876,276
				Filing Date	October 6, 2015
				First Named Inventor	James J. FALLON
				Art Unit	2634
				Examiner Name	3403
Sheet	4	of	7	Attorney Docket Number	3421.005000C

NON PATENT LITERATURE DOCUMENTS			
Examiner Initials*	Cite No. <sup>1</sup>	Include name of the author (in CAPITAL LETTERS), title of the article (when appropriate), title of the item (book, magazine, journal, serial, symposium, catalog, etc.), date, page(s), volume number, publisher, city and/or country where published	T <sup>2</sup>
	NPL31	Defendants' Motion to Supplement the Claim Construction Record, filed in Realtime Data LLC d/b/a IXO v. Actian Corporation, et al., Case No. 6:15-cv-00463-RWS-JDL (E.D. Texas), and Realtime Data LLC d/b/a IXO v. Oracle America Inc., Case No. 6:16-cv-00088-RWS-JDL (E.D. Texas), filed July 11, 2016; 10 pages.	
	NPL32	Joint Claim Construction and Prehearing Statement, filed in Realtime Data LLC d/b/a IXO v. Oracle America Inc., Case No. 6:16-cv-00088-RWS-JDL (E.D. Texas), filed July 13, 2016; 5 pages.	
	NPL33	Exhibit A to Joint Claim Construction and Prehearing Statement, filed in Realtime Data LLC d/b/a IXO v. Oracle America Inc., Case No. 6:16-cv-00088-RWS-JDL (E.D. Texas), filed July 11, 2016; 5 pages.	
	NPL34	Plaintiff Realtime Data LLC's Response to Defendants' Motion to Supplement the Claim Construction Record, filed in Realtime Data LLC d/b/a IXO v. Actian Corporation et al., Case No. 6:15-cv-00463-RWS-JDL (E.D. Texas), and Realtime Data LLC d/b/a IXO v. Oracle America, Inc., Case No. 6:15-cv-00088-RWS-JDL (E.D. Texas), filed July 14, 2016; 14 pages.	
	NPL35	Complaint for Patent Infringement Against Rackspace US, Inc., Netapp, Inc., and Solidfire, Inc., filed in Realtime Data LLC d/b/a IXO v. Rackspace US, Inc., et al., Case No. 6:16-cv-00961 (E.D. Texas), filed June 29, 2016; 216 pages.	
	NPL36	Complaint for Patent Infringement Against Fujitsu America, Inc. and Quantum Corporation, filed in Realtime Data LLC d/b/a IXO v. Fujitsu America, Inc. et al., No. 6:16-cv-01035 (E.D. Texas), filed July 21, 2016; 137 pages.	
	NPL37	Complaint for Patent Infringement Against Vembu Technologies, Inc., filed in Realtime Data LLC d/b/a IXO v. Vembu Technologies, Inc., No. 6:16-cv-01037 (E.D. Texas), filed July 22, 2016; 86 pages.	
	NPL38	Copy of Non-Final Office Action for U.S. Patent Appl. No. 14/844,973, mailed May 17, 2016; 18 pages.	
	NPL39	Copy of Non-Final Office Action for U.S. Patent Appl. No. 14/727,309, mailed June 7, 2016; 15 pages.	
	NPL40	Notice of Intent to Issue Inter Partes Reexamination Certificate, in Inter Partes Reexamination of U.S. Patent No. 7,777,651, Control No. 95/001,581, mailed June 2, 2016; 5 pages.	
Examiner Signature		Date Considered	

\*EXAMINER: Initial if reference considered, whether or not citation is in conformance with MPEP 609. Draw line through citation if not in conformance and not considered. Include copy of this form with next communication to applicant.

<sup>1</sup> Applicant's unique citation designation number (optional). <sup>2</sup> Applicant is to place a check mark here if English language Translation is attached.

Substitute for form 1449/PTO				<b>Complete if Known</b>	
<b>SEVENTH SUPPLEMENTAL INFORMATION DISCLOSURE STATEMENT BY APPLICANT</b> <i>(Use as many sheets as necessary)</i>				Application Number	14/876.276
				Filing Date	October 6, 2015
				First Named Inventor	James J. FALLON
				Art Unit	2634
				Examiner Name	3403
Sheet	5	of	7	Attorney Docket Number	3421.005000C

NON PATENT LITERATURE DOCUMENTS			
Examiner Initials*	Cite No. <sup>1</sup>	Include name of the author (in CAPITAL LETTERS), title of the article (when appropriate), title of the item (book, magazine, journal, serial, symposium, catalog, etc.), date, page(s), volume number, publisher, city and/or country where published	T <sup>2</sup>
	NPL41	Notice of Intent to Issue Inter Partes Reexamination Certificate, in Inter Partes Reexamination of U.S. Patent No. 7,417,568, Control No. 95/001,533, mailed June 14, 2016; 6 pages.	
	NPL42	Inter Partes Reexamination Certificate, in Inter Partes Reexamination of U.S. Patent No. 7,777,651, Control No. 95/001,581, issued July 7, 2016; 2 pages.	
	NPL43	Notice of Intent to Issue Inter Partes Reexamination Certificate, in Inter Partes Reexamination of U.S. Patent No. 7,400,274, Control No. 95/001,544, mailed July 15, 2016; 5 pages.	
	NPL44	Inter Partes Reexamination Certificate, in Inter Partes Reexamination of U.S. Patent No. 7,417,568, Control No. 95/001,533, issued July 22, 2016; 2 pages.	
	NPL45	Institution Decision, mailed in Oracle America, Inc. et al. v. Realtime Data LLC, Case No. IPR2016-00373 (P.T.A.B.), mailed June 27, 2016; 32 pages.	
	NPL46	Institution Decision, mailed in Oracle America, Inc. et al. v. Realtime Data LLC, Case No. IPR2016-00374 (P.T.A.B.), mailed June 27, 2016; 28 pages.	
	NPL47	Decision Denying Institution, mailed in Oracle America, Inc. et al. v. Realtime Data LLC, Case No. IPR2016-00375 (P.T.A.B.), mailed July 1, 2016; 13 pages.	
	NPL48	Decision Denying Institution, mailed in Oracle America, Inc. et al. v. Realtime Data LLC, Case No. IPR2016-00376 (P.T.A.B.), mailed July 1, 2016; 18 pages.	
	NPL49	Decision Denying Institution, mailed in Oracle America, Inc. et al. v. Realtime Data LLC, Case No. IPR2016-00377 (P.T.A.B.), mailed July 1, 2016; 16 pages.	
	NPL50	Petition for Inter Partes Review of United States Patent No. 7,181,608 Pursuant to 35 U.S.C. 311-319, 37 C.F.R. 42, filed in Apple Inc. v. Realtime Data LLC, Case No. IPR2016-01365 (P.T.A.B.), filed July 8, 2016; 77 pages.	
Examiner Signature		Date Considered	

\*EXAMINER: Initial if reference considered, whether or not citation is in conformance with MPEP 609. Draw line through citation if not in conformance and not considered. Include copy of this form with next communication to applicant.

<sup>1</sup> Applicant's unique citation designation number (optional). <sup>2</sup> Applicant is to place a check mark here if English language Translation is attached.

Substitute for form 1449/PTO		<b>Complete if Known</b>	
<b>SEVENTH SUPPLEMENTAL INFORMATION DISCLOSURE STATEMENT BY APPLICANT</b> <i>(Use as many sheets as necessary)</i>		Application Number	14/876,276
		Filing Date	October 6, 2015
		First Named Inventor	James J. FALLON
		Art Unit	2634
		Examiner Name	3403
		Attorney Docket Number	3421.005000C
Sheet	6	of	7

NON PATENT LITERATURE DOCUMENTS			
Examiner Initials*	Cite No. <sup>1</sup>	Include name of the author (in CAPITAL LETTERS), title of the article (when appropriate), title of the item (book, magazine, journal, serial, symposium, catalog, etc.), date, page(s), volume number, publisher, city and/or country where published	T <sup>2</sup>
	NPL51	File History of U.S. Patent No. 7,181,608, U.S. Patent Application No. 09/776,267, filed February 2, 2001; 507 pages.	
	NPL52	Declaration of Dr. Charles J. Neuhauser, filed in Apple Inc. v. Realtime Data LLC, Case No. IPR2016-01365 (P.T.A.B.), filed July 8, 2016; 174 pages.	
	NPL53	BURROWS, ET AL., "On-Line Data Compression in a Log-structured File System," Fifth International Conference on Architectural Support for Programming Languages and Operating Systems, October 12-15, 1992; 27 pages.	
	NPL54	Excerpts from HENNESSY, ET AL., Computer Architecture - A Quantitative Approach, San Mateo, CA: Morgan Kaufmann Publishers, 1990; p. 403-425, 535-538.	
	NPL55	PROSISE, J., "DOS 6: The Ultimate Software Bundle?", PC Magazine, Vol. 12, No. 7, April 13, 1993; 29 pages. (Submitted in 2 parts.)	
	NPL56	Excerpts from Microsoft Press Computer Dictionary, Third Edition, Redmond, WA: Microsoft Press, 1997; pp. 194-196.	
	NPL57	Excerpts from SHANLEY, ET AL., PCI System Architecture, Fourth Edition, New York: Addison Wesley, 1999; pp. 7-13.	
	NPL58	STORER, ET AL., "Data Compression via Textual Substitution," Journal of the Association for Computing Machinery, Vol. 29, No. 4, October 1982; 24 pages.	
	NPL59	Petition for Inter Partes Review of United States Patent No. 8,090,936 Pursuant to 35 U.S.C. 311-319, 37 C.F.R. 42, filed in Apple Inc. v. Realtime Data LLC, Case No. IPR2016-01366 (P.T.A.B.), filed July 8, 2016; 77 pages.	
	NPL60	File History of U.S. Patent No. 8,090,936, U.S. Patent Application No. 11/551,204, filed October 19, 2006; 970 pages.	

Examiner Signature	Date Considered
-----------------------	--------------------

\*EXAMINER: Initial if reference considered, whether or not citation is in conformance with MPEP 609. Draw line through citation if not in conformance and not considered. Include copy of this form with next communication to applicant.

<sup>1</sup> Applicant's unique citation designation number (optional). <sup>2</sup> Applicant is to place a check mark here if English language Translation is attached.





## Electronic Patent Application Fee Transmittal

<b>Application Number:</b>	14876276			
<b>Filing Date:</b>	06-Oct-2015			
<b>Title of Invention:</b>	Video Data Compression Systems			
<b>First Named Inventor/Applicant Name:</b>	James J. FALLON			
<b>Filer:</b>	Michael V. Messinger/Wilson Smith			
<b>Attorney Docket Number:</b>	3421.005000C			
Filed as Large Entity				
<b>Filing Fees for Utility under 35 USC 111(a)</b>				
<b>Description</b>	<b>Fee Code</b>	<b>Quantity</b>	<b>Amount</b>	<b>Sub-Total in USD(\$)</b>
<b>Basic Filing:</b>				
<b>Pages:</b>				
<b>Claims:</b>				
<b>Miscellaneous-Filing:</b>				
<b>Petition:</b>				
<b>Patent-Appeals-and-Interference:</b>				
<b>Post-Allowance-and-Post-Issuance:</b>				
<b>Extension-of-Time:</b>				

Description	Fee Code	Quantity	Amount	Sub-Total in USD(\$)
<b>Miscellaneous:</b>				
RCE- 2nd and Subsequent Request	1820	1	1700	1700
<b>Total in USD (\$)</b>				<b>1700</b>

## Electronic Acknowledgement Receipt

<b>EFS ID:</b>	26475320
<b>Application Number:</b>	14876276
<b>International Application Number:</b>	
<b>Confirmation Number:</b>	3403
<b>Title of Invention:</b>	Video Data Compression Systems
<b>First Named Inventor/Applicant Name:</b>	James J. FALLON
<b>Customer Number:</b>	26111
<b>Filer:</b>	Michael V. Messinger/William Flanigen
<b>Filer Authorized By:</b>	Michael V. Messinger
<b>Attorney Docket Number:</b>	3421.005000C
<b>Receipt Date:</b>	27-JUL-2016
<b>Filing Date:</b>	06-OCT-2015
<b>Time Stamp:</b>	19:43:13
<b>Application Type:</b>	Utility under 35 USC 111(a)

### Payment information:

Submitted with Payment	yes
Payment Type	Credit Card
Payment was successfully received in RAM	\$1700
RAM confirmation Number	5559
Deposit Account	
Authorized User	

The Director of the USPTO is hereby authorized to charge indicated fees and credit any overpayment as follows:

<b>File Listing:</b>					
<b>Document Number</b>	<b>Document Description</b>	<b>File Name</b>	<b>File Size(Bytes)/ Message Digest</b>	<b>Multi Part /.zip</b>	<b>Pages (if appl.)</b>
1	Non Patent Literature	NPL60_IPR201601366_1002_936_FH.pdf	13216668 b332a914cfb4a045df52ba65b8d2bc511640eec5	no	970
<b>Warnings:</b>					
<b>Information:</b>					
2	Non Patent Literature	NPL61_IPR201601366_1003_Neuhauser_Decl_07082016.pdf	667532 4661322f09188714537177b74e2f3eebc88987e5	no	157
<b>Warnings:</b>					
<b>Information:</b>					
3	Non Patent Literature	NPL62_Rackspace_Docket_06302016.pdf	50214 f0a5556d1a5b55238e4f81348b51725119682264	no	2
<b>Warnings:</b>					
<b>Information:</b>					
4	Non Patent Literature	NPL63_Fujitsu_Docket_History_07272016.pdf	53344 ef9cbd69001812ccb9a608865938af2277bd2aa0	no	2
<b>Warnings:</b>					
<b>Information:</b>					
5	Non Patent Literature	NPL64_Vembu_Docket_History_07272016.pdf	53896 283c65079a539195e6f8e47148db7bba66d32390	no	2
<b>Warnings:</b>					
<b>Information:</b>					
6		3421005000C_7SIDS.pdf	2580251 23419f7a011fb0f3274317fa208e0fd0184df011	yes	19
	<b>Multipart Description/PDF files in .zip description</b>				
	<b>Document Description</b>	<b>Start</b>	<b>End</b>		

	Miscellaneous Incoming Letter	1	1
	Request for Continued Examination (RCE)	2	2
	Transmittal Letter	3	11
	Information Disclosure Statement (IDS) Form (SB08)	12	19

**Warnings:**

**Information:**

7	Fee Worksheet (SB06)	fee-info.pdf	30296	no	2
			e43767ddb46e92be8db1081bca1d97fb0 457755		

**Warnings:**

**Information:**

<b>Total Files Size (in bytes):</b>	16652201
-------------------------------------	----------

**This Acknowledgement Receipt evidences receipt on the noted date by the USPTO of the indicated documents, characterized by the applicant, and including page counts, where applicable. It serves as evidence of receipt similar to a Post Card, as described in MPEP 503.**

**New Applications Under 35 U.S.C. 111**

**If a new application is being filed and the application includes the necessary components for a filing date (see 37 CFR 1.53(b)-(d) and MPEP 506), a Filing Receipt (37 CFR 1.54) will be issued in due course and the date shown on this Acknowledgement Receipt will establish the filing date of the application.**

**National Stage of an International Application under 35 U.S.C. 371**

**If a timely submission to enter the national stage of an international application is compliant with the conditions of 35 U.S.C. 371 and other applicable requirements a Form PCT/DO/EO/903 indicating acceptance of the application as a national stage submission under 35 U.S.C. 371 will be issued in addition to the Filing Receipt, in due course.**

**New International Application Filed with the USPTO as a Receiving Office**

**If a new international application is being filed and the international application includes the necessary components for an international filing date (see PCT Article 11 and MPEP 1810), a Notification of the International Application Number and of the International Filing Date (Form PCT/RO/105) will be issued in due course, subject to prescriptions concerning national security, and the date shown on this Acknowledgement Receipt will establish the international filing date of the application.**

MICHAEL V. MESSINGER  
DIRECTOR  
(202) 772-8667  
MIKEM@SKGF.COM



July 27, 2016

Commissioner for Patents  
PO Box 1450  
Alexandria, VA 22313-1450

Confirmation No. 3403  
Art Unit 2634  
*Attn: Mail Stop Amendment*

Re: U.S. Utility Patent Application  
Application No. 14/876,276; Filing Date: October 6, 2015  
For: **Video Data Compression Systems**  
Inventors: FALLON *et al.*  
Our Ref: 3421.005000C

Commissioner:

Transmitted herewith for appropriate action are the following documents:

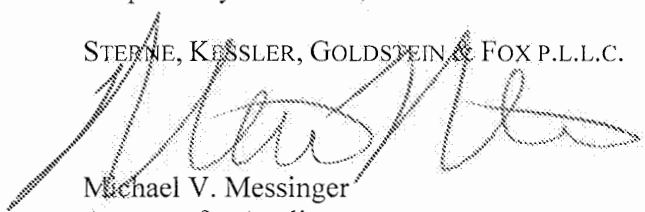
1. Online Credit Card Payment Authorization in the amount of \$1,700.00 in payment of the fee under 37 C.F.R. § 1.17(e)(2);
2. Request for Continued Examination (PTO/SB/30);
3. Seventh Supplemental Information Disclosure Statement;
4. Form PTO/SB/08a (1 sheet) listing 7 documents (**US1-US7**);
5. Form PTO/SB/08b (7 sheets) listing 64 documents (**NPL1-NPL64**); and
6. Copies of cited documents (**NPL1-NPL64**).

In the event that extensions of time are necessary to prevent abandonment of this patent application, then such extensions of time are hereby petitioned.

Fee The U.S. Patent and Trademark Office is hereby authorized to charge any fee deficiency, or credit any overpayment, to our Deposit Account No. 19-0036.

Respectfully submitted,

STERNE, KESSLER, GOLDSTEIN & FOX P.L.L.C.



Michael V. Messinger  
Attorney for Applicant  
Registration No. 37,575

MVM/MRM/wcf  
Enclosures

2842687\_1.DOCX



US007417568C1

(12) **INTER PARTES REEXAMINATION CERTIFICATE** (1308th)

**United States Patent**

**Fallon et al.**

(10) **Number:** **US 7,417,568 C1**

(45) **Certificate Issued:** **Jul. 22, 2016**

(54) **SYSTEM AND METHOD FOR DATA FEED ACCELERATION AND ENCRYPTION**

*G06Q 50/18* (2012.01)

*H04L 12/18* (2006.01)

*H04L 29/08* (2006.01)

*H04L 29/06* (2006.01)

(75) Inventors: **James J. Fallon**, Armonk, NY (US);  
**Paul F. Pickel**, Bethpage, NY (US);  
**Stephen J. McErlain**, New York, NY (US);  
**Carlton J. Melone**, Ridgewood, NJ (US)

(52) **U.S. Cl.**

CPC ..... *G06Q 40/04* (2013.01); *G06Q 50/188*

(2013.01); *H04L 12/1895* (2013.01); *H04L*

*29/06027* (2013.01); *H04L 65/607* (2013.01);

*H04L 65/80* (2013.01); *H04L 67/26* (2013.01);

*H04L 69/04* (2013.01)

(73) Assignee: **REALTIME DATA, LLC**, New York, NY (US)

(58) **Field of Classification Search**

USPC ..... 341/51

See application file for complete search history.

**Reexamination Request:**

No. 95/001,533, Mar. 1, 2011

**Reexamination Certificate for:**

Patent No.: **7,417,568**

Issued: **Aug. 26, 2008**

Appl. No.: **10/434,305**

Filed: **May 7, 2003**

(56)

**References Cited**

To view the complete listing of prior art documents cited during the proceeding for Reexamination Control Number 95/001,533, please refer to the USPTO's public Patent Application Information Retrieval (PAIR) system under the Display References tab.

Certificate of Correction issued Jan. 6, 2009

**Related U.S. Application Data**

(63) Continuation-in-part of application No. 09/969,987, filed on Oct. 3, 2001, now Pat. No. 9,143,546.

(60) Provisional application No. 60/237,571, filed on Oct. 3, 2000, provisional application No. 60/378,517, filed on May 7, 2002.

*Primary Examiner* — Deandra Hughes

(57)

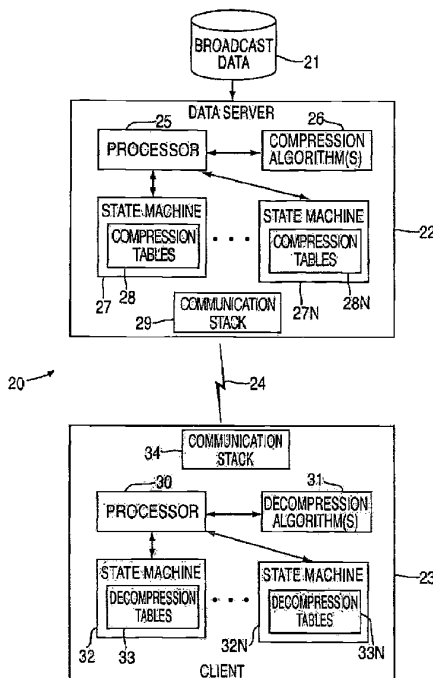
**ABSTRACT**

Systems and methods for providing accelerated transmission of broadcast data, such as financial data and news feeds, over a communication channel using data compression and decompression to provide secure transmission and transparent multiplication of communication bandwidth, as well as reduce the latency associated with data transmission of conventional systems.

(51) **Int. Cl.**

*H03M 7/38* (2006.01)

*G06Q 40/04* (2012.01)



**1**  
**INTER PARTES**  
**REEXAMINATION CERTIFICATE**

**2**

THE PATENT IS HEREBY AMENDED AS 5  
INDICATED BELOW.

AS A RESULT OF REEXAMINATION, IT HAS BEEN  
DETERMINED THAT:

Claims 1-41, 45-62, 67, 69 and 70 are cancelled. 10  
Claims 42-44, 63-66 and 68 were not reexamined.

\* \* \* \* \*



## Electronic Acknowledgement Receipt

<b>EFS ID:</b>	26475067
<b>Application Number:</b>	14876276
<b>International Application Number:</b>	
<b>Confirmation Number:</b>	3403
<b>Title of Invention:</b>	Video Data Compression Systems
<b>First Named Inventor/Applicant Name:</b>	James J. FALLON
<b>Customer Number:</b>	26111
<b>Filer:</b>	Michael V. Messinger/William Flanigen
<b>Filer Authorized By:</b>	Michael V. Messinger
<b>Attorney Docket Number:</b>	3421.005000C
<b>Receipt Date:</b>	27-JUL-2016
<b>Filing Date:</b>	06-OCT-2015
<b>Time Stamp:</b>	19:45:13
<b>Application Type:</b>	Utility under 35 USC 111(a)

### Payment information:

Submitted with Payment	no
------------------------	----

### File Listing:

Document Number	Document Description	File Name	File Size(Bytes)/ Message Digest	Multi Part /.zip	Pages (if appl.)
1	Non Patent Literature	NPL1_Teradata_Amended_Co mplaint_05172016.pdf	560550  1d54993756f1ce46f94d71594e74d05a7666886b	no	58

### Warnings:

<b>Information:</b>					
2	Non Patent Literature	NPL2_HP_Answer_05202016.pdf	69721 07c16abfe547425e159030866263f5a01508e8a9	no	20
<b>Warnings:</b>					
<b>Information:</b>					
3	Non Patent Literature	NPL3_Realttime_Opening_CC_Brief_05232016.pdf	408358 9cfbfe7e5de4e570716827f79a4440c13be66945	no	37
<b>Warnings:</b>					
<b>Information:</b>					
4	Non Patent Literature	NPL4_Agreed_and_Disputed_Construction_05232016.pdf	41230 b3370feee44a0375760e2ba4898759417ace17f31	no	4
<b>Warnings:</b>					
The page size in the PDF is too large. The pages should be 8.5 x 11 or A4. If this PDF is submitted, the pages will be resized upon entry into the Image File Wrapper and may affect subsequent processing					
<b>Information:</b>					
5	Non Patent Literature	NPL5_Zeger_Declaration_05232016.pdf	293212 0e812d9edcfd9b6f3855ea30278376327d544b5	no	21
<b>Warnings:</b>					
<b>Information:</b>					
6	Non Patent Literature	NPL6_Silver_Peak_Answer_06032016.pdf	71185 3e746586b967b348f06a171916f95fad19574cdc	no	23
<b>Warnings:</b>					
<b>Information:</b>					
7	Non Patent Literature	NPL7_Veritas_Answer_06062016.pdf	105541 8149e418d163c1853152368d5053f5bb1a473a6e	no	30
<b>Warnings:</b>					
<b>Information:</b>					
8	Non Patent Literature	NPL8_Dell_Amended_Complaint_06092016.pdf	664764 a53bde5dd66223b2cf0372045f77d3c297eccca4	no	47
<b>Warnings:</b>					

<b>Information:</b>					
9	Non Patent Literature	NPL9_Savvis_Answer_06132016.pdf	56171 c31a5ab43c2842cbf00285cf7946946cf66abb97	no	16
<b>Warnings:</b>					
<b>Information:</b>					
10	Non Patent Literature	NPL10_Responsive_CC_Brief_06132016.pdf	364043 451374d710e75fde0cd30e2cfa7e00444779e9f3	no	39
<b>Warnings:</b>					
<b>Information:</b>					
11	Non Patent Literature	NPL11_Dell_Creusere_Declaration_06132016.pdf	80785 517fc0f5ff1004b672667f3522a407e0926c1148	no	10
<b>Warnings:</b>					
<b>Information:</b>					
12	Non Patent Literature	NPL12_Dict_of_Electronics.pdf	372969 63986a44980d59880cd41a99807b69143b1a7745	no	5
<b>Warnings:</b>					
<b>Information:</b>					
13	Non Patent Literature	NPL13_Dell_Motion_Summary_Judgment_06132016.pdf	126631 ed2837ba385fcd33237c99be4e758f9d7ab7c3f6	no	15
<b>Warnings:</b>					
<b>Information:</b>					
14	Non Patent Literature	NPL14_Prov_App_60136561.pdf	434579 c61826ccf7a4ebca168dabc0407d5f4371646613	no	24
<b>Warnings:</b>					
<b>Information:</b>					
15	Non Patent Literature	NPL15_Storer_Declaration_06132016.pdf	374050 cd8a9e551239e6d97892fa04f8bf389f82b6f12f	no	37
<b>Warnings:</b>					
<b>Information:</b>					

16	Non Patent Literature	NPL16_Dell_Answer_to_Amended_Complaint_06232016.pdf	52095 a37d3707dcd004aada3f2b1126189f396369c9d4	no	17
<b>Warnings:</b>					
<b>Information:</b>					
17	Non Patent Literature	NPL17_Actian_Motion_Supplement_Invalidity_06242016.pdf	58501 97ef2ed50e3c76b928e7093fd5cab286731a4f4	no	12
<b>Warnings:</b>					
<b>Information:</b>					
18	Non Patent Literature	NPL18_Actian_Motion_Amend_Invalidity_Ex_A_06242016.pdf	376668 993fca0064386666a1ff17d74459b95bde680baa	no	19
<b>Warnings:</b>					
The page size in the PDF is too large. The pages should be 8.5 x 11 or A4. If this PDF is submitted, the pages will be resized upon entry into the Image File Wrapper and may affect subsequent processing					
<b>Information:</b>					
19	Non Patent Literature	NPL19_Actian_Motion_Amend_Invalidity_Ex_B_06242016.pdf	53800 076ff3fce63663c67a39fb96ce8ea69d12a73208	no	5
<b>Warnings:</b>					
The page size in the PDF is too large. The pages should be 8.5 x 11 or A4. If this PDF is submitted, the pages will be resized upon entry into the Image File Wrapper and may affect subsequent processing					
<b>Information:</b>					
20	Non Patent Literature	NPL20_Actian_Motion_Amend_Invalidity_Ex_C_06242016.pdf	387569 665cdd85953b85cdeb38c3566ab4e2a952519b10	no	20
<b>Warnings:</b>					
The page size in the PDF is too large. The pages should be 8.5 x 11 or A4. If this PDF is submitted, the pages will be resized upon entry into the Image File Wrapper and may affect subsequent processing					
<b>Information:</b>					
21	Non Patent Literature	NPL21_Actian_Motion_Amend_Invalidity_Ex_D_06242016.pdf	388930 a7676d2d5081b37e1d695d46f1563afdf17b16e2	no	20
<b>Warnings:</b>					
The page size in the PDF is too large. The pages should be 8.5 x 11 or A4. If this PDF is submitted, the pages will be resized upon entry into the Image File Wrapper and may affect subsequent processing					
<b>Information:</b>					

22	Non Patent Literature	NPL22_Actian_Motion_Amend _Invalidity_Ex_E_06242016.pdf	995487	no	53
			05fbdb80e279aa8fabb4bd3bf64930c1cc271929		
<b>Warnings:</b>					
The page size in the PDF is too large. The pages should be 8.5 x 11 or A4. If this PDF is submitted, the pages will be resized upon entry into the Image File Wrapper and may affect subsequent processing					
<b>Information:</b>					
23	Non Patent Literature	NPL23_Actian_Motion_Amend _Invalidity_Ex_F_06242016.pdf	266079	no	16
			5afdc5ecff38ebc4f1d6d65e6c216514d2c9ff12		
<b>Warnings:</b>					
The page size in the PDF is too large. The pages should be 8.5 x 11 or A4. If this PDF is submitted, the pages will be resized upon entry into the Image File Wrapper and may affect subsequent processing					
<b>Information:</b>					
24	Non Patent Literature	NPL24_Actian_Motion_Amend _Invalidity_Ex_M_06242016. pdf	79670	no	20
			001716bc494521a8c1ec1f1e3903721d87a06518		
<b>Warnings:</b>					
<b>Information:</b>					
25	Non Patent Literature	NPL25_Realtime_Reply_CC_Brief_06272016.pdf	82606	no	15
			999579ac3b24dc5d9b6225c1f39add513bcf5d2f		
<b>Warnings:</b>					
<b>Information:</b>					
26	Non Patent Literature	NPL26_Realtime_Response_Motion_Partial_Summary_Judgment_06272016.pdf	113587	no	20
			819a159f84b6c0be7d0b41765260634954da6		
<b>Warnings:</b>					
<b>Information:</b>					
27	Non Patent Literature	NPL27_Brief_Supporting_Motion_for_Summary_Judgment_06302016.pdf	81616	no	9
			91effdbad9ac720cb044a7147072e18e19906a54		
<b>Warnings:</b>					
<b>Information:</b>					
28	Non Patent Literature	NPL28_Joint_CC_Chart_A_06302016.pdf	38715	no	3
			e444c8884a637c13592b50b8803dbed7ad0da90d		

<b>Warnings:</b>					
The page size in the PDF is too large. The pages should be 8.5 x 11 or A4. If this PDF is submitted, the pages will be resized upon entry into the Image File Wrapper and may affect subsequent processing					
<b>Information:</b>					
29	Non Patent Literature	NPL29_Joint_CC_Chart_B_063 02016.pdf	193122  638a306cbf0736d61c9f7671b40fa56708d03ac0	no	18
<b>Warnings:</b>					
The page size in the PDF is too large. The pages should be 8.5 x 11 or A4. If this PDF is submitted, the pages will be resized upon entry into the Image File Wrapper and may affect subsequent processing					
<b>Information:</b>					
30	Non Patent Literature	NPL30_Realtime_Notice_of_Su ppl_Facts_07052016.pdf	32032  0c5733ca39d782c005e76bd40be00ad8e143e504	no	3
<b>Warnings:</b>					
<b>Information:</b>					
31	Non Patent Literature	NPL31_Oracle_Motion_to_Sup pl_CC_Record_07112016.pdf	45822  7a941dde376b1fa66ceb46b6b48b06037a47cc2c	no	10
<b>Warnings:</b>					
<b>Information:</b>					
32	Non Patent Literature	NPL32_Joint_CC_Statement_0 7132016.pdf	43308  f7f46af5287fcf996e263cb443a422762e678e7d	no	5
<b>Warnings:</b>					
<b>Information:</b>					
33	Non Patent Literature	NPL33_Joint_CC_Statement_E x_A_07132016.pdf	56485  c7de7bfc8b56d7062b484c18786259f94eb5703e	no	5
<b>Warnings:</b>					
The page size in the PDF is too large. The pages should be 8.5 x 11 or A4. If this PDF is submitted, the pages will be resized upon entry into the Image File Wrapper and may affect subsequent processing					
<b>Information:</b>					
34	Non Patent Literature	NPL34_Realtime_Response_to _Motion_to_Suppl_CC_Record _07142016.pdf	99668  6de08fdeb265cc3bf9bebc1057a7c7e0365a1f93	no	14
<b>Warnings:</b>					
<b>Information:</b>					

35	Non Patent Literature	NPL35_Rackspace_Complaint_06292016.pdf	2270488	no	216
			c7a94e99cf67811961206b0a2be233e27ec56acc		
<b>Warnings:</b>					
<b>Information:</b>					
36	Non Patent Literature	NPL36_Fujitsu_Complaint_07212016.pdf	1302477	no	137
			2c54d914d8a179380b3308dfac5df24be45e9ecf		
<b>Warnings:</b>					
<b>Information:</b>					
37	Non Patent Literature	NPL37_Vembu_Complaint_07222016.pdf	836346	no	86
			badaa78f5637ce5a98877af817591fd12d77578e		
<b>Warnings:</b>					
<b>Information:</b>					
38	Non Patent Literature	NPL38_NFOA_14844973_05172016.pdf	83435	no	18
			20f5605117c0069f1ab06f69b98267cda74a1930		
<b>Warnings:</b>					
<b>Information:</b>					
39	Non Patent Literature	NPL39_NFOA_14727309_06072016.pdf	72208	no	15
			cdae208eceb6cbfc23cc23713897f799b527e494		
<b>Warnings:</b>					
<b>Information:</b>					
40	Non Patent Literature	NPL40_NIIRC_95001581_06022016.pdf	34078	no	5
			297766e3a222eb4d72696c8adf3b25d8f1199b1b		
<b>Warnings:</b>					
<b>Information:</b>					
41	Non Patent Literature	NPL41_NIIRC_95001533_06142016.pdf	40745	no	6
			e3d32e225ac506ba2b0ae8bab117d2c7ce0c49E3		
<b>Warnings:</b>					
<b>Information:</b>					

42	Non Patent Literature	NPL42_Reexam_Cert_95001581_07082016.pdf	22619	no	2
			2fad885064bf03593c0b8881849498f5d8af aled		
<b>Warnings:</b>					
<b>Information:</b>					
43	Non Patent Literature	NPL43_NIIRC_95001544_07152016.pdf	38704	no	5
			fd4355802a38025ba54a44461f9c683c186a 284c		
<b>Warnings:</b>					
<b>Information:</b>					
44	Non Patent Literature	NPL44_Reexam_Cert_95001533_07222016.pdf	25517	no	2
			1ff54453805b0f1ff9b32ceae2d490a3518e9 89b		
<b>Warnings:</b>					
<b>Information:</b>					
45	Non Patent Literature	NPL45_IPR201600373_Institution_Decision_06272016.pdf	192996	no	32
			ea63ae92cceb57810e90343eb659fda2246 22ee0		
<b>Warnings:</b>					
<b>Information:</b>					
46	Non Patent Literature	NPL46_IPR201600374_Institution_Decision_06272016.pdf	168181	no	28
			03a772d3b380d25849a46c8a16a688c09d 463df		
<b>Warnings:</b>					
<b>Information:</b>					
47	Non Patent Literature	NPL47_IPR201600375_Institution_Decision_07012016.pdf	61002	no	13
			24a411a4b2ac7cee6fe3d85746f47436887f 497f		
<b>Warnings:</b>					
<b>Information:</b>					
48	Non Patent Literature	NPL48_IPR201600376_Institution_Decision_07012016.pdf	90606	no	18
			a3c357c0b405f14d783c41ddaafda4675ffb a647		
<b>Warnings:</b>					
<b>Information:</b>					



49	Non Patent Literature	NPL49_IPR201600377_Institution_Decision_07012016.pdf	93218	no	16
			1b2dd76e6c66f93933aa0ce6029eac43443b4e45		
<b>Warnings:</b>					
<b>Information:</b>					
50	Non Patent Literature	NPL50_IPR201601365_Petition_07082016.pdf	505563	no	77
			c8e045c0d4ace1b54c8ae60f9d19826eb39da9dd		
<b>Warnings:</b>					
<b>Information:</b>					
51	Non Patent Literature	NPL51_IPR201601365_1002_608_FH.pdf	6197849	no	507
			61beec8010bb75a611dad81d873cb68618c781ec		
<b>Warnings:</b>					
<b>Information:</b>					
52	Non Patent Literature	NPL52_IPR201601365_1003_Neuhauser_Decl_07082016.pdf	676680	no	174
			2a0455dae701f094a84816cc7a2977b06d5d515c		
<b>Warnings:</b>					
<b>Information:</b>					
53	Non Patent Literature	NPL53_IPR201601365_1007_Burrows_1992.pdf	113409	no	27
			7871707c76ce07cdaba28f2fc0f4d11b4a0b357		
<b>Warnings:</b>					
<b>Information:</b>					
54	Non Patent Literature	NPL54_IPR201601365_1010_Hennessey_1990.pdf	1728887	no	36
			7d4e76e92fd63e95bca4b745257bd3e63b24a8f6		
<b>Warnings:</b>					
<b>Information:</b>					
55	Non Patent Literature	NPL55_IPR201601365_1010_Part1of2_Prosize_1993.pdf	8488160	no	29
			f3d6e281aa8143252c1b5dcbe250d664a0abb005		
<b>Warnings:</b>					
<b>Information:</b>					

56	Non Patent Literature	NPL55_IPR201601365_1010_Pa rt2of2_Prosize_1993.pdf	1764954	no	13
			9471292d5c403a2dd8f781098e258557333 815c5		
<b>Warnings:</b>					
<b>Information:</b>					
57	Non Patent Literature	NPL56_IPR201601365_1013_M icrosoft_Comp_Dict_1997.pdf	263628	no	5
			2b91111185f5844530cf4481210bb64979a 0f3e7		
<b>Warnings:</b>					
<b>Information:</b>					
58	Non Patent Literature	NPL57_IPR201601365_1014_P CI_System_Architecture_1999. pdf	537938	no	11
			2becc04cf1dbd5e79d8928624dd3bf8aa82 697a5		
<b>Warnings:</b>					
<b>Information:</b>					
59	Non Patent Literature	NPL58_IPR201601365_1016_St orer_1982.pdf	1029964	no	24
			a344b55850ca50f6fdd20699413b8cb1b82 7383		
<b>Warnings:</b>					
<b>Information:</b>					
60	Non Patent Literature	NPL59_IPR201601366_Petition _07082016.pdf	542493	no	77
			ef858a6828e549cbcdaf57bbac1ffe7518578 0890		
<b>Warnings:</b>					
<b>Information:</b>					
<b>Total Files Size (in bytes):</b>			34651694		

**This Acknowledgement Receipt evidences receipt on the noted date by the USPTO of the indicated documents, characterized by the applicant, and including page counts, where applicable. It serves as evidence of receipt similar to a Post Card, as described in MPEP 503.**

**New Applications Under 35 U.S.C. 111**

**If a new application is being filed and the application includes the necessary components for a filing date (see 37 CFR 1.53(b)-(d) and MPEP 506), a Filing Receipt (37 CFR 1.54) will be issued in due course and the date shown on this Acknowledgement Receipt will establish the filing date of the application.**

**National Stage of an International Application under 35 U.S.C. 371**

**If a timely submission to enter the national stage of an international application is compliant with the conditions of 35 U.S.C. 371 and other applicable requirements a Form PCT/DO/EO/903 indicating acceptance of the application as a national stage submission under 35 U.S.C. 371 will be issued in addition to the Filing Receipt, in due course.**

**New International Application Filed with the USPTO as a Receiving Office**

**If a new international application is being filed and the international application includes the necessary components for an international filing date (see PCT Article 11 and MPEP 1810), a Notification of the International Application Number and of the International Filing Date (Form PCT/RO/105) will be issued in due course, subject to prescriptions concerning national security, and the date shown on this Acknowledgement Receipt will establish the international filing date of the application.**

Under the Paperwork Reduction Act of 1995, no persons are required to respond to a collection of information unless it displays a valid OMB control number.

<b>PATENT APPLICATION FEE DETERMINATION RECORD</b> Substitute for Form PTO-875	Application or Docket Number 14/876,276	Filing Date 10/06/2015	<input type="checkbox"/> To be Mailed
---	--	---------------------------	---------------------------------------

ENTITY:  LARGE  SMALL  MICRO

**APPLICATION AS FILED – PART I**

FOR	NUMBER FILED	NUMBER EXTRA	RATE (\$)	FEE (\$)
<input type="checkbox"/> BASIC FEE (37 CFR 1.16(a), (b), or (c))	N/A	N/A	N/A	
<input type="checkbox"/> SEARCH FEE (37 CFR 1.16(k), (j), or (m))	N/A	N/A	N/A	
<input type="checkbox"/> EXAMINATION FEE (37 CFR 1.16(o), (p), or (q))	N/A	N/A	N/A	
TOTAL CLAIMS (37 CFR 1.16(i))	minus 20 =	*	X \$ =	
INDEPENDENT CLAIMS (37 CFR 1.16(h))	minus 3 =	*	X \$ =	
<input type="checkbox"/> APPLICATION SIZE FEE (37 CFR 1.16(s))	If the specification and drawings exceed 100 sheets of paper, the application size fee due is \$310 (\$155 for small entity) for each additional 50 sheets or fraction thereof. See 35 U.S.C. 41(a)(1)(G) and 37 CFR 1.16(s).			
<input type="checkbox"/> MULTIPLE DEPENDENT CLAIM PRESENT (37 CFR 1.16(j))				
* If the difference in column 1 is less than zero, enter "0" in column 2.			TOTAL	

**APPLICATION AS AMENDED – PART II**

	(Column 1)	(Column 2)	(Column 3)	PRESENT EXTRA	RATE (\$)	ADDITIONAL FEE (\$)
<b>AMENDMENT</b>	07/27/2016	CLAIMS REMAINING AFTER AMENDMENT	HIGHEST NUMBER PREVIOUSLY PAID FOR			
	Total (37 CFR 1.16(i))	* 30	Minus ** 30	= 0	x \$80 =	0
	Independent (37 CFR 1.16(h))	* 2	Minus *** 3	= 0	x \$420 =	0
	<input type="checkbox"/> Application Size Fee (37 CFR 1.16(s))					
<input type="checkbox"/> FIRST PRESENTATION OF MULTIPLE DEPENDENT CLAIM (37 CFR 1.16(j))						
					TOTAL ADD'L FEE	<b>0</b>

	(Column 1)	(Column 2)	(Column 3)	PRESENT EXTRA	RATE (\$)	ADDITIONAL FEE (\$)
<b>AMENDMENT</b>		CLAIMS REMAINING AFTER AMENDMENT	HIGHEST NUMBER PREVIOUSLY PAID FOR			
	Total (37 CFR 1.16(i))	*	Minus **	=	X \$ =	
	Independent (37 CFR 1.16(h))	*	Minus ***	=	X \$ =	
	<input type="checkbox"/> Application Size Fee (37 CFR 1.16(s))					
<input type="checkbox"/> FIRST PRESENTATION OF MULTIPLE DEPENDENT CLAIM (37 CFR 1.16(j))						
					TOTAL ADD'L FEE	

\* If the entry in column 1 is less than the entry in column 2, write "0" in column 3.  
 \*\* If the "Highest Number Previously Paid For" IN THIS SPACE is less than 20, enter "20".  
 \*\*\* If the "Highest Number Previously Paid For" IN THIS SPACE is less than 3, enter "3".  
 The "Highest Number Previously Paid For" (Total or Independent) is the highest number found in the appropriate box in column 1.

LIE  
/DEBRA SAVOY/

This collection of information is required by 37 CFR 1.16. The information is required to obtain or retain a benefit by the public which is to file (and by the USPTO to process) an application. Confidentiality is governed by 35 U.S.C. 122 and 37 CFR 1.14. This collection is estimated to take 12 minutes to complete, including gathering, preparing, and submitting the completed application form to the USPTO. Time will vary depending upon the individual case. Any comments on the amount of time you require to complete this form and/or suggestions for reducing this burden, should be sent to the Chief Information Officer, U.S. Patent and Trademark Office, U.S. Department of Commerce, P.O. Box 1450, Alexandria, VA 22313-1450. DO NOT SEND FEES OR COMPLETED FORMS TO THIS ADDRESS. **SEND TO: Commissioner for Patents, P.O. Box 1450, Alexandria, VA 22313-1450.**

If you need assistance in completing the form, call 1-800-PTO-9199 and select option 2.



UNITED STATES PATENT AND TRADEMARK OFFICE

UNITED STATES DEPARTMENT OF COMMERCE
United States Patent and Trademark Office
Address: COMMISSIONER FOR PATENTS
P.O. Box 1450
Alexandria, Virginia 22313-1450
www.uspto.gov

NOTICE OF ALLOWANCE AND FEE(S) DUE

26111 7590 08/12/2016
STERNE, KESSLER, GOLDSTEIN & FOX P.L.L.C.
1100 NEW YORK AVENUE, N.W.
WASHINGTON, DC 20005

EXAMINER

BOCURE, TESFALDET

ART UNIT PAPER NUMBER

2634

DATE MAILED: 08/12/2016

Table with 5 columns: APPLICATION NO., FILING DATE, FIRST NAMED INVENTOR, ATTORNEY DOCKET NO., CONFIRMATION NO.
14/876,276 10/06/2015 James J. FALLON 3421.005000C 3403

TITLE OF INVENTION: Video Data Compression Systems

Table with 7 columns: APPLN. TYPE, ENTITY STATUS, ISSUE FEE DUE, PUBLICATION FEE DUE, PREV. PAID ISSUE FEE, TOTAL FEE(S) DUE, DATE DUE
nonprovisional UNDISCOUNTED \$960 \$0 \$0 \$960 11/14/2016

THE APPLICATION IDENTIFIED ABOVE HAS BEEN EXAMINED AND IS ALLOWED FOR ISSUANCE AS A PATENT. PROSECUTION ON THE MERITS IS CLOSED. THIS NOTICE OF ALLOWANCE IS NOT A GRANT OF PATENT RIGHTS. THIS APPLICATION IS SUBJECT TO WITHDRAWAL FROM ISSUE AT THE INITIATIVE OF THE OFFICE OR UPON PETITION BY THE APPLICANT. SEE 37 CFR 1.313 AND MPEP 1308.

THE ISSUE FEE AND PUBLICATION FEE (IF REQUIRED) MUST BE PAID WITHIN THREE MONTHS FROM THE MAILING DATE OF THIS NOTICE OR THIS APPLICATION SHALL BE REGARDED AS ABANDONED. THIS STATUTORY PERIOD CANNOT BE EXTENDED. SEE 35 U.S.C. 151. THE ISSUE FEE DUE INDICATED ABOVE DOES NOT REFLECT A CREDIT FOR ANY PREVIOUSLY PAID ISSUE FEE IN THIS APPLICATION. IF AN ISSUE FEE HAS PREVIOUSLY BEEN PAID IN THIS APPLICATION (AS SHOWN ABOVE), THE RETURN OF PART B OF THIS FORM WILL BE CONSIDERED A REQUEST TO REAPPLY THE PREVIOUSLY PAID ISSUE FEE TOWARD THE ISSUE FEE NOW DUE.

HOW TO REPLY TO THIS NOTICE:

I. Review the ENTITY STATUS shown above. If the ENTITY STATUS is shown as SMALL or MICRO, verify whether entitlement to that entity status still applies.

If the ENTITY STATUS is the same as shown above, pay the TOTAL FEE(S) DUE shown above.

If the ENTITY STATUS is changed from that shown above, on PART B - FEE(S) TRANSMITTAL, complete section number 5 titled "Change in Entity Status (from status indicated above)".

For purposes of this notice, small entity fees are 1/2 the amount of undiscounted fees, and micro entity fees are 1/2 the amount of small entity fees.

II. PART B - FEE(S) TRANSMITTAL, or its equivalent, must be completed and returned to the United States Patent and Trademark Office (USPTO) with your ISSUE FEE and PUBLICATION FEE (if required). If you are charging the fee(s) to your deposit account, section "4b" of Part B - Fee(s) Transmittal should be completed and an extra copy of the form should be submitted. If an equivalent of Part B is filed, a request to reapply a previously paid issue fee must be clearly made, and delays in processing may occur due to the difficulty in recognizing the paper as an equivalent of Part B.

III. All communications regarding this application must give the application number. Please direct all communications prior to issuance to Mail Stop ISSUE FEE unless advised to the contrary.

IMPORTANT REMINDER: Utility patents issuing on applications filed on or after Dec. 12, 1980 may require payment of maintenance fees. It is patentee's responsibility to ensure timely payment of maintenance fees when due.

**PART B - FEE(S) TRANSMITTAL**

**Complete and send this form, together with applicable fee(s), to: Mail Mail Stop ISSUE FEE  
 Commissioner for Patents  
 P.O. Box 1450  
 Alexandria, Virginia 22313-1450  
 or Fax (571)-273-2885**

**INSTRUCTIONS:** This form should be used for transmitting the ISSUE FEE and PUBLICATION FEE (if required). Blocks 1 through 5 should be completed where appropriate. All further correspondence including the Patent, advance orders and notification of maintenance fees will be mailed to the current correspondence address as indicated unless corrected below or directed otherwise in Block 1, by (a) specifying a new correspondence address; and/or (b) indicating a separate "FEE ADDRESS" for maintenance fee notifications.

CURRENT CORRESPONDENCE ADDRESS (Note: Use Block 1 for any change of address)

26111                      7590                      08/12/2016  
**STERNE, KESSLER, GOLDSTEIN & FOX P.L.L.C.**  
 1100 NEW YORK AVENUE, N.W.  
 WASHINGTON, DC 20005

Note: A certificate of mailing can only be used for domestic mailings of the Fee(s) Transmittal. This certificate cannot be used for any other accompanying papers. Each additional paper, such as an assignment or formal drawing, must have its own certificate of mailing or transmission.

**Certificate of Mailing or Transmission**

I hereby certify that this Fee(s) Transmittal is being deposited with the United States Postal Service with sufficient postage for first class mail in an envelope addressed to the Mail Stop ISSUE FEE address above, or being facsimile transmitted to the USPTO (571) 273-2885, on the date indicated below.

_____ (Depositor's name)
_____ (Signature)
_____ (Date)

APPLICATION NO.	FILING DATE	FIRST NAMED INVENTOR	ATTORNEY DOCKET NO.	CONFIRMATION NO.
14/876,276	10/06/2015	James J. FALLON	3421.005000C	3403

TITLE OF INVENTION: Video Data Compression Systems

APPLN. TYPE	ENTITY STATUS	ISSUE FEE DUE	PUBLICATION FEE DUE	PREV. PAID ISSUE FEE	TOTAL FEE(S) DUE	DATE DUE
nonprovisional	UNDISCOUNTED	\$960	\$0	\$0	\$960	11/14/2016

EXAMINER	ART UNIT	CLASS-SUBCLASS
BOCURE, TESFALDET	2634	375-240100

<p>1. Change of correspondence address or indication of "Fee Address" (37 CFR 1.363).</p> <p><input type="checkbox"/> Change of correspondence address (or Change of Correspondence Address form PTO/SB/122) attached.</p> <p><input type="checkbox"/> "Fee Address" indication (or "Fee Address" Indication form PTO/SB/47; Rev 03-02 or more recent) attached. <b>Use of a Customer Number is required.</b></p>	<p>2. For printing on the patent front page, list</p> <p>(1) The names of up to 3 registered patent attorneys or agents OR, alternatively, 1 _____</p> <p>(2) The name of a single firm (having as a member a registered attorney or agent) and the names of up to 2 registered patent attorneys or agents. If no name is listed, no name will be printed. 2 _____</p> <p>3 _____</p>
---	---

3. ASSIGNEE NAME AND RESIDENCE DATA TO BE PRINTED ON THE PATENT (print or type)

PLEASE NOTE: Unless an assignee is identified below, no assignee data will appear on the patent. If an assignee is identified below, the document has been filed for recordation as set forth in 37 CFR 3.11. Completion of this form is NOT a substitute for filing an assignment.

(A) NAME OF ASSIGNEE \_\_\_\_\_ (B) RESIDENCE: (CITY and STATE OR COUNTRY) \_\_\_\_\_

Please check the appropriate assignee category or categories (will not be printed on the patent):  Individual  Corporation or other private group entity  Government

<p>4a. The following fee(s) are submitted:</p> <p><input type="checkbox"/> Issue Fee</p> <p><input type="checkbox"/> Publication Fee (No small entity discount permitted)</p> <p><input type="checkbox"/> Advance Order - # of Copies _____</p>	<p>4b. Payment of Fee(s): (Please first reapply any previously paid issue fee shown above)</p> <p><input type="checkbox"/> A check is enclosed.</p> <p><input type="checkbox"/> Payment by credit card. Form PTO-2038 is attached.</p> <p><input type="checkbox"/> The director is hereby authorized to charge the required fee(s), any deficiency, or credits any overpayment, to Deposit Account Number _____ (enclose an extra copy of this form).</p>
---	---

5. Change in Entity Status (from status indicated above)

Applicant certifying micro entity status. See 37 CFR 1.29

Applicant asserting small entity status. See 37 CFR 1.27

Applicant changing to regular undiscounted fee status.

**NOTE:** Absent a valid certification of Micro Entity Status (see forms PTO/SB/15A and 15B), issue fee payment in the micro entity amount will not be accepted at the risk of application abandonment.

**NOTE:** If the application was previously under micro entity status, checking this box will be taken to be a notification of loss of entitlement to micro entity status.

**NOTE:** Checking this box will be taken to be a notification of loss of entitlement to small or micro entity status, as applicable.

NOTE: This form must be signed in accordance with 37 CFR 1.31 and 1.33. See 37 CFR 1.4 for signature requirements and certifications.

Authorized Signature \_\_\_\_\_ Date \_\_\_\_\_

Typed or printed name \_\_\_\_\_ Registration No. \_\_\_\_\_



UNITED STATES PATENT AND TRADEMARK OFFICE

UNITED STATES DEPARTMENT OF COMMERCE
United States Patent and Trademark Office
Address: COMMISSIONER FOR PATENTS
P.O. Box 1450
Alexandria, Virginia 22313-1450
www.uspto.gov

Table with 5 columns: APPLICATION NO., FILING DATE, FIRST NAMED INVENTOR, ATTORNEY DOCKET NO., CONFIRMATION NO.
14/876,276 10/06/2015 James J. FALLON 3421.005000C 3403

26111 7590 08/12/2016
STERNE, KESSLER, GOLDSTEIN & FOX P.L.L.C.
1100 NEW YORK AVENUE, N.W.
WASHINGTON, DC 20005

EXAMINER

BOCURE, TESFALDET

ART UNIT PAPER NUMBER

2634

DATE MAILED: 08/12/2016

Determination of Patent Term Adjustment under 35 U.S.C. 154 (b)
(Applications filed on or after May 29, 2000)

The Office has discontinued providing a Patent Term Adjustment (PTA) calculation with the Notice of Allowance.

Section 1(h)(2) of the AIA Technical Corrections Act amended 35 U.S.C. 154(b)(3)(B)(i) to eliminate the requirement that the Office provide a patent term adjustment determination with the notice of allowance. See Revisions to Patent Term Adjustment, 78 Fed. Reg. 19416, 19417 (Apr. 1, 2013). Therefore, the Office is no longer providing an initial patent term adjustment determination with the notice of allowance. The Office will continue to provide a patent term adjustment determination with the Issue Notification Letter that is mailed to applicant approximately three weeks prior to the issue date of the patent, and will include the patent term adjustment on the patent. Any request for reconsideration of the patent term adjustment determination (or reinstatement of patent term adjustment) should follow the process outlined in 37 CFR 1.705.

Any questions regarding the Patent Term Extension or Adjustment determination should be directed to the Office of Patent Legal Administration at (571)-272-7702. Questions relating to issue and publication fee payments should be directed to the Customer Service Center of the Office of Patent Publication at 1-(888)-786-0101 or (571)-272-4200.

## OMB Clearance and PRA Burden Statement for PTOL-85 Part B

The Paperwork Reduction Act (PRA) of 1995 requires Federal agencies to obtain Office of Management and Budget approval before requesting most types of information from the public. When OMB approves an agency request to collect information from the public, OMB (i) provides a valid OMB Control Number and expiration date for the agency to display on the instrument that will be used to collect the information and (ii) requires the agency to inform the public about the OMB Control Number's legal significance in accordance with 5 CFR 1320.5(b).

The information collected by PTOL-85 Part B is required by 37 CFR 1.311. The information is required to obtain or retain a benefit by the public which is to file (and by the USPTO to process) an application. Confidentiality is governed by 35 U.S.C. 122 and 37 CFR 1.14. This collection is estimated to take 12 minutes to complete, including gathering, preparing, and submitting the completed application form to the USPTO. Time will vary depending upon the individual case. Any comments on the amount of time you require to complete this form and/or suggestions for reducing this burden, should be sent to the Chief Information Officer, U.S. Patent and Trademark Office, U.S. Department of Commerce, P.O. Box 1450, Alexandria, Virginia 22313-1450. DO NOT SEND FEES OR COMPLETED FORMS TO THIS ADDRESS. SEND TO: Commissioner for Patents, P.O. Box 1450, Alexandria, Virginia 22313-1450. Under the Paperwork Reduction Act of 1995, no persons are required to respond to a collection of information unless it displays a valid OMB control number.

### Privacy Act Statement

**The Privacy Act of 1974 (P.L. 93-579)** requires that you be given certain information in connection with your submission of the attached form related to a patent application or patent. Accordingly, pursuant to the requirements of the Act, please be advised that: (1) the general authority for the collection of this information is 35 U.S.C. 2(b)(2); (2) furnishing of the information solicited is voluntary; and (3) the principal purpose for which the information is used by the U.S. Patent and Trademark Office is to process and/or examine your submission related to a patent application or patent. If you do not furnish the requested information, the U.S. Patent and Trademark Office may not be able to process and/or examine your submission, which may result in termination of proceedings or abandonment of the application or expiration of the patent.

The information provided by you in this form will be subject to the following routine uses:

1. The information on this form will be treated confidentially to the extent allowed under the Freedom of Information Act (5 U.S.C. 552) and the Privacy Act (5 U.S.C. 552a). Records from this system of records may be disclosed to the Department of Justice to determine whether disclosure of these records is required by the Freedom of Information Act.
2. A record from this system of records may be disclosed, as a routine use, in the course of presenting evidence to a court, magistrate, or administrative tribunal, including disclosures to opposing counsel in the course of settlement negotiations.
3. A record in this system of records may be disclosed, as a routine use, to a Member of Congress submitting a request involving an individual, to whom the record pertains, when the individual has requested assistance from the Member with respect to the subject matter of the record.
4. A record in this system of records may be disclosed, as a routine use, to a contractor of the Agency having need for the information in order to perform a contract. Recipients of information shall be required to comply with the requirements of the Privacy Act of 1974, as amended, pursuant to 5 U.S.C. 552a(m).
5. A record related to an International Application filed under the Patent Cooperation Treaty in this system of records may be disclosed, as a routine use, to the International Bureau of the World Intellectual Property Organization, pursuant to the Patent Cooperation Treaty.
6. A record in this system of records may be disclosed, as a routine use, to another federal agency for purposes of National Security review (35 U.S.C. 181) and for review pursuant to the Atomic Energy Act (42 U.S.C. 218(c)).
7. A record from this system of records may be disclosed, as a routine use, to the Administrator, General Services, or his/her designee, during an inspection of records conducted by GSA as part of that agency's responsibility to recommend improvements in records management practices and programs, under authority of 44 U.S.C. 2904 and 2906. Such disclosure shall be made in accordance with the GSA regulations governing inspection of records for this purpose, and any other relevant (i.e., GSA or Commerce) directive. Such disclosure shall not be used to make determinations about individuals.
8. A record from this system of records may be disclosed, as a routine use, to the public after either publication of the application pursuant to 35 U.S.C. 122(b) or issuance of a patent pursuant to 35 U.S.C. 151. Further, a record may be disclosed, subject to the limitations of 37 CFR 1.14, as a routine use, to the public if the record was filed in an application which became abandoned or in which the proceedings were terminated and which application is referenced by either a published application, an application open to public inspection or an issued patent.
9. A record from this system of records may be disclosed, as a routine use, to a Federal, State, or local law enforcement agency, if the USPTO becomes aware of a violation or potential violation of law or regulation.



<b>Notice of Allowability</b>	<b>Application No.</b> 14/876,276	<b>Applicant(s)</b> FALLON ET AL.	
	<b>Examiner</b> TESFALDET BOCURE	<b>Art Unit</b> 2634	<b>AIA (First Inventor to File) Status</b> No

**-- The MAILING DATE of this communication appears on the cover sheet with the correspondence address--**

All claims being allowable, PROSECUTION ON THE MERITS IS (OR REMAINS) CLOSED in this application. If not included herewith (or previously mailed), a Notice of Allowance (PTOL-85) or other appropriate communication will be mailed in due course. **THIS NOTICE OF ALLOWABILITY IS NOT A GRANT OF PATENT RIGHTS.** This application is subject to withdrawal from issue at the initiative of the Office or upon petition by the applicant. See 37 CFR 1.313 and MPEP 1308.

1.  This communication is responsive to IDS and RCE filed on 07/27/2016.  
 A declaration(s)/affidavit(s) under **37 CFR 1.130(b)** was/were filed on \_\_\_\_\_.
2.  An election was made by the applicant in response to a restriction requirement set forth during the interview on \_\_\_\_\_; the restriction requirement and election have been incorporated into this action.
3.  The allowed claim(s) is/are 1-30. As a result of the allowed claim(s), you may be eligible to benefit from the **Patent Prosecution Highway** program at a participating intellectual property office for the corresponding application. For more information, please see [http://www.uspto.gov/patents/init\\_events/pph/index.jsp](http://www.uspto.gov/patents/init_events/pph/index.jsp) or send an inquiry to PPHfeedback@uspto.gov.
4.  Acknowledgment is made of a claim for foreign priority under 35 U.S.C. § 119(a)-(d) or (f).

**Certified copies:**

a)  All    b)  Some    \*c)  None of the:

1.  Certified copies of the priority documents have been received.
2.  Certified copies of the priority documents have been received in Application No. \_\_\_\_\_.
3.  Copies of the certified copies of the priority documents have been received in this national stage application from the International Bureau (PCT Rule 17.2(a)).

\* Certified copies not received: \_\_\_\_\_.

Applicant has THREE MONTHS FROM THE "MAILING DATE" of this communication to file a reply complying with the requirements noted below. Failure to timely comply will result in ABANDONMENT of this application.

**THIS THREE-MONTH PERIOD IS NOT EXTENDABLE.**

5.  CORRECTED DRAWINGS ( as "replacement sheets") must be submitted.  
 including changes required by the attached Examiner's Amendment / Comment or in the Office action of Paper No./Mail Date \_\_\_\_\_.  
**Identifying indicia such as the application number (see 37 CFR 1.84(c)) should be written on the drawings in the front (not the back) of each sheet. Replacement sheet(s) should be labeled as such in the header according to 37 CFR 1.121(d).**
6.  DEPOSIT OF and/or INFORMATION about the deposit of BIOLOGICAL MATERIAL must be submitted. Note the attached Examiner's comment regarding REQUIREMENT FOR THE DEPOSIT OF BIOLOGICAL MATERIAL.

**Attachment(s)**

- |   |   |
|---|---|
| 1. <input type="checkbox"/> Notice of References Cited (PTO-892)  | 5. <input checked="" type="checkbox"/> Examiner's Amendment/Comment       |
| 2. <input checked="" type="checkbox"/> Information Disclosure Statements (PTO/SB/08),<br>Paper No./Mail Date <u>7/27/2016</u> | 6. <input type="checkbox"/> Examiner's Statement of Reasons for Allowance |
| 3. <input type="checkbox"/> Examiner's Comment Regarding Requirement for Deposit<br>of Biological Material                    | 7. <input type="checkbox"/> Other _____.                                  |
| 4. <input type="checkbox"/> Interview Summary (PTO-413),<br>Paper No./Mail Date _____.  |   |

/TESFALDET BOCURE/  
Primary Examiner, Art Unit 2634

**DETAILED ACTION**

1. The present application is being examined under the pre-AIA first to invent provisions.
2. This office action (Notice of Allowance) is in response to the IDS and RCE filed on 07/27/2016. The pending claims 1-30 are now allowed.

***Continued Examination Under 37 CFR 1.114***

3. A request for continued examination under 37 CFR 1.114, including the fee set forth in 37 CFR 1.17(e), was filed in this application after allowance or after an Office action under *Ex Parte Quayle*, 25 USPQ 74, 453 O.G. 213 (Comm'r Pat. 1935). Since this application is eligible for continued examination under 37 CFR 1.114, and the fee set forth in 37 CFR 1.17(e) has been timely paid, prosecution in this application has been reopened pursuant to 37 CFR 1.114. Applicant's submission filed on 07/27/2016 has been entered.

***Information Disclosure Statement***

4. The information disclosure statements (IDS) submitted on 07/27/2016 (two IDSs filed on the same date are in compliance with the provisions of 37 CFR 1.97. Accordingly, the information disclosure statement is being considered by the examiner. Attached with this correspondence are the initialed copies of the IDSs.

***Conclusion***

5. Any inquiry concerning this communication or earlier communications from the examiner should be directed to TESFALDET BOCURE whose telephone number is (571)272-3015. The examiner can normally be reached on 8:30am-to-5:00pm.

If attempts to reach the examiner by telephone are unsuccessful, the examiner's supervisor, Daniel C. Washburn can be reached on 571-272-5551. The fax phone number for the organization where this application or proceeding is assigned is 571-273-8300.

Information regarding the status of an application may be obtained from the Patent Application Information Retrieval (PAIR) system. Status information for published applications may be obtained from either Private PAIR or Public PAIR. Status information for unpublished applications is available through Private PAIR only. For more information about the PAIR system, see <http://pair-direct.uspto.gov>. Should you have questions on access to the Private PAIR system, contact the Electronic Business Center (EBC) at 866-217-9197 (toll-free). If you would like assistance from a USPTO Customer Service Representative or access to the automated information system, call 800-786-9199 (IN USA OR CANADA) or 571-272-1000.

/TESFALDET BOCURE/  
Primary Examiner, Art Unit 2634

/T. B./  
Primary Examiner, Art Unit 2634

## WEST Search History for Application 14876276

Creation Date: 2016080516:44

### Prior Art Searches

Query	DB	Hits	Op.	Plur.	Thes.	Date
((Fallen adj James).in. or (McErlain adj Stephen).in.)	PGPB, USPT, USOC, EPAB, JPAB, DWPI, TDBD	47	OR	YES		08-05-2016
((Fallen).in. or (McErlain).in.)	PGPB, USPT, USOC, EPAB, JPAB, DWPI, TDBD	181	OR	YES		08-05-2016
(select\$4 or choos\$4) near4 ((multiple or plural\$4 or two or three or four or five) near5 encoder\$) same ((assymetric\$ or (lempel adj2 ziv)) near4 (compressing or compression))	PGPB, USPT, USOC, EPAB, JPAB, DWPI, TDBD	0	OR	YES		08-05-2016
(select\$4 or choos\$4) near4 ((multiple or plural\$4 or two or three or four or five) near5 encoder\$) and ((assymetric\$ or (lempel adj2 ziv)) near4 (compressing or compression))	PGPB, USPT, USOC, EPAB, JPAB, DWPI, TDBD	74	OR	YES		08-05-2016
((select\$4 or choos\$4) near4 ((multiple or plural\$4 or two or three or four or five) near5 encoder\$) and ((assymetric\$ or (lempel adj2 ziv)) near4 (compressing or compression)) ) and @ad<=20010213	PGPB, USPT, USOC, EPAB, JPAB, DWPI, TDBD	4	OR	YES		08-05-2016
((select\$4 or choos\$4) near4 ((multiple or plural\$4 or two or three or four or five) near5 encoder\$) and ((assymetric\$ or (lempel adj2	PGPB, USPT, USOC,	37	OR	YES		08-05-2016

ziv)) near4 (compressing or compression)) ) and ( (((Fallen adj James).in. or (McErlain adj Stephen).in.) ) or (((Fallen).in. or (McErlain).in.) ) )	EPAB, JPAB, DWPI, TDBD					
((select\$4 or choos\$4) near4 ((multiple or plural\$4 or two or three or four or five) near5 encoder\$) and ((assymetric\$ or (lempel adj2 ziv)) near4 (compressing or compression)) ) and ( (((Fallen adj James).in. or (McErlain adj Stephen).in.) ) )	PGPB, USPT, USOC, EPAB, JPAB, DWPI, TDBD	36	OR	YES		08-05-2016
(selecting or select or choose or choosing) near4 ((compress or compression or compressing) near4 (algorithm or algorithms or mode or modes)) same ((assymetric\$4 or (lempel adj2 ziv)) near4 (compressing or compression))	PGPB, USPT, USOC, EPAB, JPAB, DWPI, TDBD	25	OR	YES		08-05-2016
((compress or compression or compressing) near4 (algorithm or algorithms or mode or modes)) same (parameter or parameters or attribute or attributes) same (assymetric \$4near4 (compressing or compression))	PGPB, USPT, USOC, EPAB, JPAB, DWPI, TDBD	6071	OR	YES		08-05-2016
((compress or compression or compressing) near4 (algorithm or algorithms or mode or modes)) same (parameter or parameters or attribute or attributes) same (assymetric\$4 near4 (compressing or compression))	PGPB, USPT, USOC, EPAB, JPAB, DWPI, TDBD	0	OR	YES		08-05-2016
((compress or compression or compressing) near4 (algorithm or algorithms or mode or modes)) same (parameter or parameters or attribute or attributes) same ((fast near4 slow) near4 (compressing or compression))	PGPB, USPT, USOC, EPAB, JPAB, DWPI, TDBD	2	OR	YES		08-05-2016
((multiple or plural\$4 or two or three or four or five) near5 encoder\$) same ((assymetric\$ or (lempel adj2 ziv)) near4 (compressing or compression))	PGPB, USPT, USOC, EPAB, JPAB, DWPI, TDBD	31	OR	YES		08-05-2016

<p>((selecting or select or choose or choosing) near4 ((compress or compression or compressing) near4 (algorithm or algorithms or mode or modes)) same ((assymetric\$4 or (lempel adj2 ziv)) near4 (compressing or compression)) ) and ((((((H03M7/30))))   (((H03M7/3084))))   (((H03M7/6094))))   (((G06F15/7867))))   (((G06T1/60))))   (((H04N19/136))))).CPC. )</p>	<p>PGPB, USPT, USOC, EPAB, JPAB, DWPI, TDBD</p>	<p>21</p>	<p>OR</p>	<p>YES</p>		<p>08-05-2016</p>
<p>((multiple or plural\$4 or two or three or four or five) near5 encoder\$) same ((assymetric\$ or (lempel adj2 ziv)) near4 (compressing or compression)) ) and ((((((H03M7/30))))   (((H03M7/3059))))   (((H03M7/3093))))   (((H04L69/04))))   (((H04N19/152))))   (((H04N9/8042))))).CPC. )</p>	<p>PGPB, USPT, USOC, EPAB, JPAB, DWPI, TDBD</p>	<p>30</p>	<p>OR</p>	<p>YES</p>		<p>08-05-2016</p>
<p>("20010019630"   "20010031092"   "20010032128"   "20010047473"   "20010052038"   "20020037035"   "20020069354"   "20020078241"   "20020080871"   "20020097172"   "20020101367"   "20020104891"   "20020126755"   "20020169950"   "20020191692"   "20030030575"   "20030034905"   "20030058873"   "20030084238").PN.</p>	<p>PGPB, USPT, USOC, EPAB, JPAB, DWPI, TDBD</p>	<p>38</p>	<p>OR</p>	<p>YES</p>		<p>08-05-2016</p>
<p>(((375/\$8))).ccls. or (((370/\$8))).ccls. or (((348/\$8))).ccls. or (((341/\$8))).ccls. or (((711/\$8))).ccls. or (((701/\$8))).ccls. or (((381/\$8))).ccls. or (((375/382))).ccls. )</p>	<p>PGPB, USPT, USOC, EPAB, JPAB, DWPI, TDBD</p>	<p>1260093</p>	<p>OR</p>	<p>YES</p>		<p>08-05-2016</p>
<p>(((375/\$8))).ccls. or (((370/\$8))).ccls. or (((348/\$8))).ccls. or (((341/\$8))).ccls. or (((711/\$8))).ccls. or (((701/\$8))).ccls. or (((381/\$8))).ccls. or (((375/382))).ccls. ) and ( ((select\$4 or choos\$4) near4 ((multiple or plural\$4 or two or three or four or five) near5 encoder\$) and ((assymetric\$ or (lempel adj2 ziv)) near4 (compressing or compression)) ) or ((selecting or select or choose or choosing) near4 ((compress or compression or compressing) near4 (algorithm or algorithms or mode or modes)) same ((assymetric\$4 or (lempel adj2 ziv)) near4 (compressing or compression)) ) or (((multiple or plural\$4 or two or three or four or five) near5 encoder\$)</p>	<p>PGPB, USPT, USOC, EPAB, JPAB, DWPI, TDBD</p>	<p>71</p>	<p>OR</p>	<p>YES</p>		<p>08-05-2016</p>

same ((assymmetric\$ or (lempel adj2 ziv)) near4 (compressing or compression)) ) )						
(((375/240))).ccls. or (((375/240.01))).ccls. or (((375/240.02))).ccls. or (((341/50))).ccls. or (((341/51))).ccls. or (((341/126))).ccls. ) and ( ((select\$4 or choos\$4) near4 ((multiple or plural\$4 or two or three or four or five) near5 encoder\$) and ((assymmetric\$ or (lempel adj2 ziv)) near4 (compressing or compression)) ) or ((selecting or select or choose or choosing) near4 ((compress or compression or compressing) near4 (algorithm or algorithms or mode or modes)) same ((assymmetric\$4 or (lempel adj2 ziv)) near4 (compressing or compression)) ) or (((multiple or plural\$4 or two or three or four or five) near5 encoder\$) same ((assymmetric\$ or (lempel adj2 ziv)) near4 (compressing or compression)) ) )	PGPB, USPT, USOC, EPAB, JPAB, DWPI, TDBD	50	OR	YES		08-05-2016
((multiple or plural\$4 or two or three or four or five) near5 encoder\$) same ((assymmetric\$3 or (lempel adj2 ziv) and (arithmetic)) near4 (compressing or compression))	PGPB, USPT, USOC, EPAB, JPAB, DWPI, TDBD	26	OR	YES		08-05-2016
( ((select\$4 or choos\$4) near4 ((multiple or plural\$4 or two or three or four or five) near5 encoder\$) and ((assymmetric\$ or (lempel adj2 ziv)) near4 (compressing or compression)) ) or ((selecting or select or choose or choosing) near4 ((compress or compression or compressing) near4 (algorithm or algorithms or mode or modes)) same ((assymmetric\$4 or (lempel adj2 ziv)) near4 (compressing or compression)) ) or (((multiple or plural\$4 or two or three or four or five) near5 encoder\$) same ((assymmetric\$ or (lempel adj2 ziv)) near4 (compressing or compression)) ) or (((multiple or plural\$4 or two or three or four or five) near5 encoder\$) same ((assymmetric\$3 or (lempel adj2 ziv) and (arithmetic)) near4 (compressing or compression)) ) )	PGPB, USPT, USOC, EPAB, JPAB, DWPI, TDBD	88	OR	YES		08-05-2016
(((select\$4 or choos\$4) near4 ((multiple or plural\$4 or two or three or four or five) near5 encoder\$) and ((assymmetric\$ or (lempel adj2 ziv)) near4 (compressing or compression)) or (selecting or select or choose or choosing) near4 ((compress or compression or	PGPB, USPT, USOC, EPAB, JPAB, DWPI,	50	OR	YES		08-05-2016

<p>compressing) near4 (algorithm or algorithms or mode or modes) same ((assymmetric\$4 or (lempel adj2 ziv)) near4 (compressing or compression) or ((multiple or plural\$4 or two or three or four or five) near5 encoder\$) same ((assymmetric\$ or (lempel adj2 ziv)) near4 (compressing or compression) or ((multiple or plural\$4 or two or three or four or five) near5 encoder\$) same ((assymmetric\$3 or (lempel adj2 ziv) and (arithmetic)) near4 (compressing or compression) ) ) and (((((375/240))))).ccls. or (((((375/240.01))))).ccls. or (((((375/240.02))))).ccls. or (((((341/50))))).ccls. or (((((341/51))))).ccls. or (((((341/126))))).ccls. ) and ((select\$4 or choos\$4) near4 ((multiple or plural\$4 or two or three or four or five) near5 encoder\$) and ((assymmetric\$ or (lempel adj2 ziv)) near4 (compressing or compression) or (selecting or select or choose or choosing) near4 ((compress or compression or compressing) near4 (algorithm or algorithms or mode or modes) same ((assymmetric\$4 or (lempel adj2 ziv)) near4 (compressing or compression) or ((multiple or plural\$4 or two or three or four or five) near5 encoder\$) same ((assymmetric\$ or (lempel adj2 ziv)) near4 (compressing or compression) ) )</p>	TDBD					
<p>((select\$4 or choos\$4) near4 ((multiple or plural\$4 or two or three or four or five) near5 encoder\$) and ((assymmetric\$ or (lempel adj2 ziv)) near4 (compressing or compression) or (selecting or select or choose or choosing) near4 ((compress or compression or compressing) near4 (algorithm or algorithms or mode or modes) same ((assymmetric\$4 or (lempel adj2 ziv)) near4 (compressing or compression) or ((multiple or plural\$4 or two or three or four or five) near5 encoder\$) same ((assymmetric\$ or (lempel adj2 ziv)) near4 (compressing or compression) or ((multiple or plural\$4 or two or three or four or five) near5 encoder\$) same ((assymmetric\$3 or (lempel adj2 ziv) and (arithmetic)) near4 (compressing or compression) ) ) and (((((375/\$8))))).ccls. or (((((370/\$8))))).ccls. or (((((348/\$8))))).ccls. or (((((341/\$8))))).ccls. or (((((711/\$8))))).ccls. or (((((701/\$8))))).ccls. or (((((381/\$8))))).ccls. or (((((375/382))))).ccls. ) )</p>	PGPB, USPT, USOC, EPAB, JPAB, DWPI, TDBD	71	OR	YES		08-05-2016
<p>((select\$4 or choos\$4) near4 ((multiple or plural\$4 or two or three or four or five) near5</p>	PGPB, USPT,	66	OR	YES		08-05-2016



<p>encoder\$) and ((assymetric\$ or (lempel adj2 ziv)) near4 (compressing or compression)) or (selecting or select or choose or choosing) near4 ((compress or compression or compressing) near4 (algorithm or algorithms or mode or modes)) same ((assymetric\$4 or (lempel adj2 ziv)) near4 (compressing or compression)) or ((multiple or plural\$4 or two or three or four or five) near5 encoder\$) same ((assymetric\$ or (lempel adj2 ziv)) near4 (compressing or compression)) or ((multiple or plural\$4 or two or three or four or five) near5 encoder\$) same ((assymetric\$3 or (lempel adj2 ziv) and (arithmetic)) near4 (compressing or compression)) ) ) and (((H03M7/30)))   (((H03M7/3059)))   (((H03M7/3084)))   (((H03M7/6094)))   (((H03M7/3088)))   (((H03M7/6023)))   (((H03M7/6064)))   (((H04N19/152)))   (((G11B20/00007))).CPC. )</p>	<p>USOC, EPAB, JPAB, DWPI, TDBD</p>					
<p>("20150334390"   "3394352"   "3490690"   "4021782"   "4032893"   "4054951"   "4127518"   "4302775"   "4325085"   "4360840"   "4386416"   "4394774"   "4464650"   "4494108"   "4499499"   "4574351"   "4626829"   "4646061"   "4682150"   "4701745").PN.</p>	<p>PGPB, USPT, USOC, EPAB, JPAB, DWPI, TDBD</p>	<p>68</p>	<p>OR</p>	<p>YES</p>		<p>08-05-2016</p>
<p>((("20150334390"   "3394352"   "3490690"   "4021782"   "4032893"   "4054951"   "4127518"   "4302775"   "4325085"   "4360840"   "4386416"   "4394774"   "4464650"   "4494108"   "4499499"   "4574351"   "4626829"   "4646061"   "4682150"   "4701745").PN. ) and ((select\$4 or choos\$4) near4 ((multiple or plural\$4 or two or three or four or five) near5 encoder\$) and ((assymetric\$ or (lempel adj2 ziv)) near4 (compressing or compression)) or (selecting or select or choose or choosing) near4 ((compress or compression or compressing) near4 (algorithm or algorithms or mode or modes)) same ((assymetric\$4 or (lempel adj2 ziv)) near4 (compressing or compression)) or ((multiple or plural\$4 or two or three or four or five) near5 encoder\$) same ((assymetric\$ or (lempel adj2 ziv)) near4 (compressing or compression)) or ((multiple or plural\$4 or two or three or four or five) near5 encoder\$) same ((assymetric\$3 or (lempel adj2 ziv) and (arithmetic)) near4 (compressing or</p>	<p>PGPB, USPT, USOC, EPAB, JPAB, DWPI, TDBD</p>	<p>1</p>	<p>OR</p>	<p>YES</p>		<p>08-05-2016</p>

compression)) ) )						
("4558302"   "4568983"   "5046119"   "5227878"   "5333212"   "5379351"   "5379356"   "5402146"   "5408542"   "5684478"   "5870036"   "6023233"   "6092071"   "6169499"   "6215983"   "6370631"   "6404919"   "20160029018"   "5479210"   "5590317"   "5710562"   "6233017"   "6744926"   "7496586"   "5479210"   "5590317"   "5710562"   "6233017"   "6744926"   "7496586"   "3560639"   "5467134"   "5623483"   "5664226").PN.	PGPB, USPT, USOC, EPAB, JPAB, DWPI, TDBD	74	OR	YES		08-05-2016
((select\$4 or choos\$4) near4 ((multiple or plural\$4 or two or three or four or five) near5 encoder\$) and ((assymetric\$ or (lempel adj2 ziv)) near4 (compressing or compression)) or (selecting or select or choose or choosing) near4 ((compress or compression or compressing) near4 (algorithm or algorithms or mode or modes)) same ((assymetric\$4 or (lempel adj2 ziv)) near4 (compressing or compression)) or ((multiple or plural\$4 or two or three or four or five) near5 encoder\$) same ((assymetric\$ or (lempel adj2 ziv)) near4 (compressing or compression)) or ((multiple or plural\$4 or two or three or four or five) near5 encoder\$) same ((assymetric\$3 or (lempel adj2 ziv) and (arithmetic)) near4 (compressing or compression)) ) ) and (((H03M7/30)   (H03M7/3084)   (H03M7/6094)   (H04N19/164)   HO4N19/176   (H04N19/103))).CPC.	PGPB, USPT, USOC, EPAB, JPAB, DWPI, TDBD	60	OR	YES		08-05-2016
("20160127512"   "20160127513"   "5479638"   "5771354").PN.	PGPB, USPT, USOC, EPAB, JPAB, DWPI, TDBD	10	OR	YES		08-05-2016
("20160162505"   "5524272"   "5860083"   "6121903"   "6185000"   "6374353"   "7096481").PN.	PGPB, USPT, USOC, EPAB, JPAB, DWPI, TDBD	16	OR	YES		08-05-2016

<p>((("20160127512"   "20160127513"   "5479638"   "5771354").PN. ) or ("20160162505"   "5524272"   "5860083"   "6121903"   "6185000"   "6374353"   "7096481").PN. ) ) and (((select\$4 or choos\$4) near4 ((multiple or plural\$4 or two or three or four or five) near5 encoder\$) and ((assymetric\$ or (lempel adj2 ziv)) near4 (compressing or compression)) or (selecting or select or choose or choosing) near4 ((compress or compression or compressing) near4 (algorithm or algorithms or mode or modes)) same ((assymetric\$4 or (lempel adj2 ziv)) near4 (compressing or compression)) or ((multiple or plural\$4 or two or three or four or five) near5 encoder\$) same ((assymetric\$ or (lempel adj2 ziv)) near4 (compressing or compression)) or ((multiple or plural\$4 or two or three or four or five) near5 encoder\$) same ((assymetric\$3 or (lempel adj2 ziv) and (arithmetic)) near4 (compressing or compression)) ) )</p>	<p>PGPB, USPT, USOC, EPAB, JPAB, DWPI, TDBD</p>	<p>2</p>	<p>OR</p>	<p>YES</p>		<p>08-05-2016</p>
--	---	----------	-----------	------------	--	-------------------

IN THE UNITED STATES PATENT AND TRADEMARK OFFICE

Inventors: FALLON *et al.*  
 Applicant: Realtime Data LLC  
 Application No.: 14/876,276  
 Filing Date: October 6, 2015

Confirmation No.: 3403  
 Art Unit: 2634  
 Examiner: 3403  
 Atty. Docket: 3421.005000C

Title: **Video Data Compression Systems**

**Seventh Supplemental Information Disclosure Statement**

*Mail Stop RCE*

Commissioner for Patents  
 PO Box 1450  
 Alexandria, VA 22313-1450

Commissioner:

Notice of Prior and Concurrent Proceedings

Applicant hereby calls to the attention of the Patent and Trademark Office the following reexamination proceedings involving patents that are commonly-assigned with the patent in the above-identified patent application:

<b>Proceeding</b>	<b>Status</b>
Inter Partes Reexamination of U.S. Patent No. 6,604,158 (Control No. 95/000,486)	Inter Partes Reexamination Certificate issued 10/10/2012
Inter Partes Reexamination of U.S. Patent No. 7,321,937 (Control No. 95/000,466)	Inter Partes Reexamination Certificate issued 05/15/2012
Inter Partes Reexamination of U.S. Patent No. 6,604,158 (Control No. 95/000,453)	Terminated
Ex Parte Reexamination of U.S. Patent No. 6,601,104 (Control No. 90/009,428)	Ex Parte Reexamination Certificate issued 02/28/2012
Inter Partes Reexamination of U.S. Patent No. 7,378,992 (Control No. 95/000,478)	Inter Partes Reexamination Certificate issued 10/04/2012
Inter Partes Reexamination of U.S. Patent No. 6,624,761 (Control No. 95/000,464)	Inter Partes Reexamination Certificate issued 06/12/2012
Inter Partes Reexamination of U.S. Patent No. 7,161,506 (Control No. 95/000,479)	Inter Partes Reexamination Certificate issued 05/22/2012

/Tsfaldet Bocure/

08/05/2016

ALL REFERENCES CONSIDERED EXCEPT WHERE LINED THROUGH. /T.B./