



# United States Patent [19]

[11] Patent Number: **6,119,208**

White et al.

[45] Date of Patent: **Sep. 12, 2000**

[54] **MVS DEVICE BACKUP SYSTEM FOR A DATA PROCESSOR USING A DATA STORAGE SUBSYSTEM SNAPSHOT COPY CAPABILITY**

• 767 431 A1 4/1997 European Pat. Off. .... G06F 11/14

[75] Inventors: **Michael Wayne White, Lafayette; Patrick James Tomsula, Arvada**, both of Colo.

*Primary Examiner*—John W. Cabeca  
*Assistant Examiner*—Tuan V. Thai  
*Attorney, Agent, or Firm*—Duft, Graziano & Forest, P.C.

[73] Assignee: **Storage Technology Corporation**, Louisville, Colo.

### [57] ABSTRACT

[21] Appl. No.: **08/844,480**

The MVS device backup system functions to enable the data processor to manage the device backup function of a disk data storage subsystem in a manner that minimizes the expenditure of data processor resources. This is accomplished by the MVS device backup system determining the source device volume on the data storage subsystem, the target device volume on the data storage subsystem and identifying the extent of both. The MVS device backup system then transmits data to the data storage subsystem, representative of the assignment of DASD full tracks from the source device location on the data storage subsystem as well as DASD full tracks from the target (backup) device location on the data storage subsystem. The data processor based MVS device backup system then uses ECAM channel programs to instruct the data storage subsystem to perform the device backup operation using snapshot track pointer copy operations. Upon conclusion of the device backup operation by the data storage subsystem, the MVS device backup system updates the meta data required to complete the device backup operation.

[22] Filed: **Apr. 18, 1997**

[51] Int. Cl.<sup>7</sup> ..... **G06F 13/00; G06F 12/00**

[52] U.S. Cl. .... **711/162; 711/111; 711/112; 711/161**

[58] Field of Search ..... **711/161, 162, 711/111, 112**

### [56] References Cited

#### U.S. PATENT DOCUMENTS

5,212,784	5/1993	Sparks	395/575
5,255,270	10/1993	Yanai et al.	371/10.2
5,276,860	1/1994	Fortier et al.	395/575
5,630,092	5/1997	Carreiro et al.	395/438
5,649,152	7/1997	Ohran et al.	395/441

#### FOREIGN PATENT DOCUMENTS

• 566 967 A2 10/1993 European Pat. Off. .... G06F 11/14

**16 Claims, 2 Drawing Sheets**

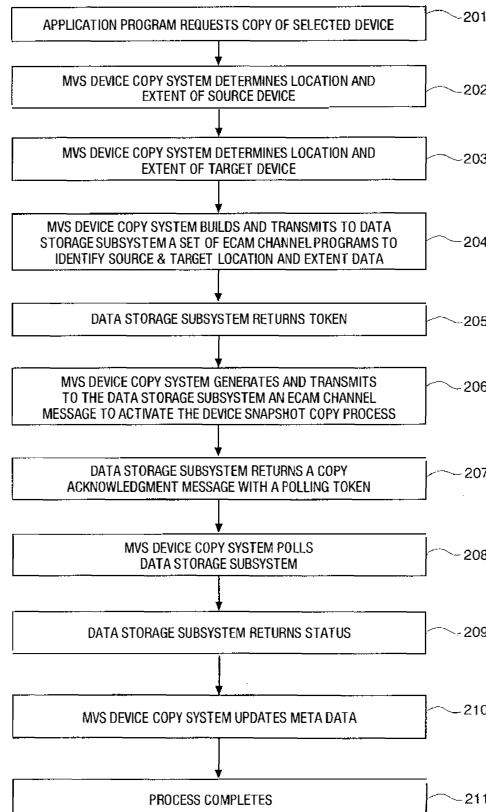

**MICROSOFT - EXHIBIT 1040  
MICROSOFT CORP. v.  
UNILOC 2017 LLC  
IPR2019-01026**

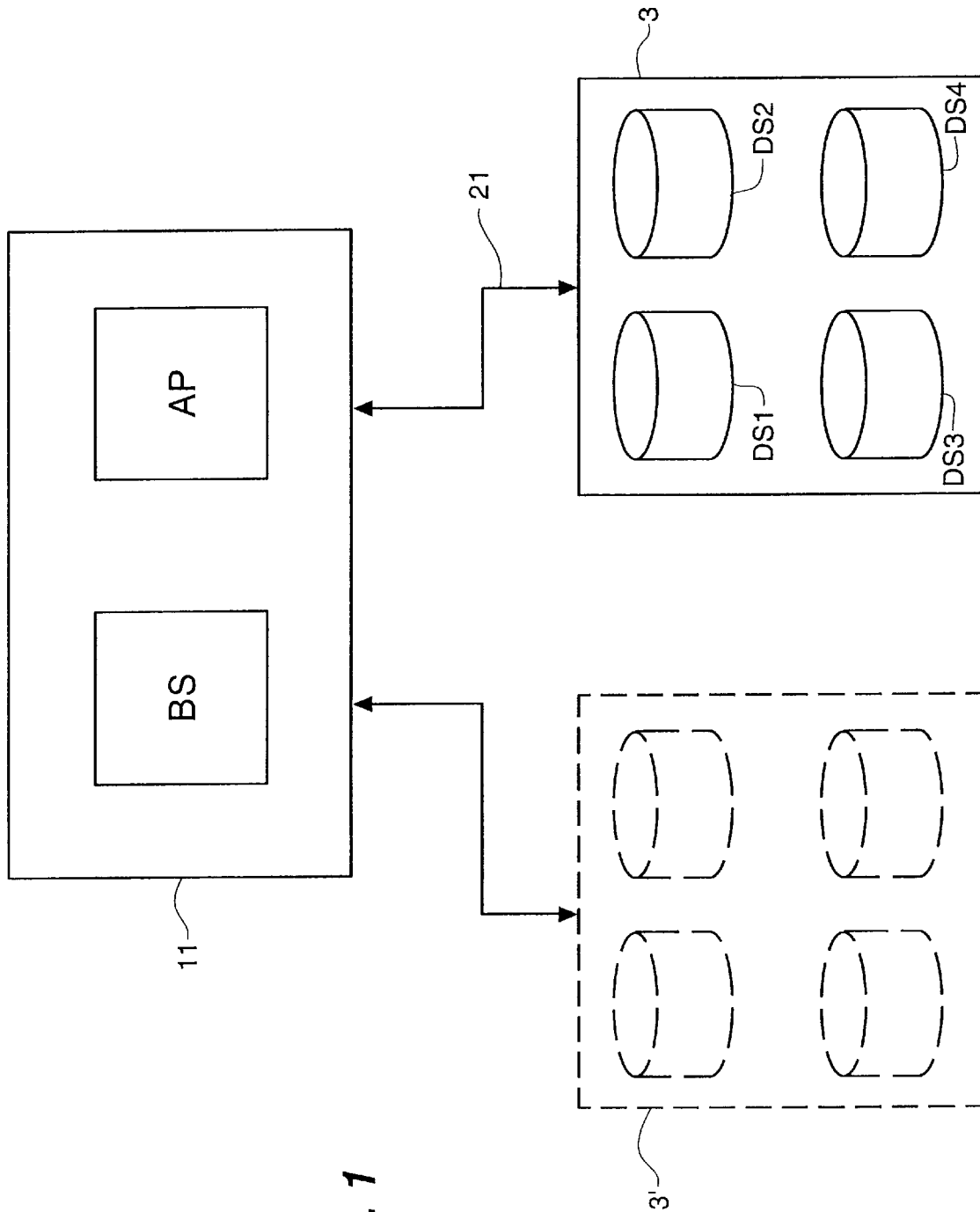
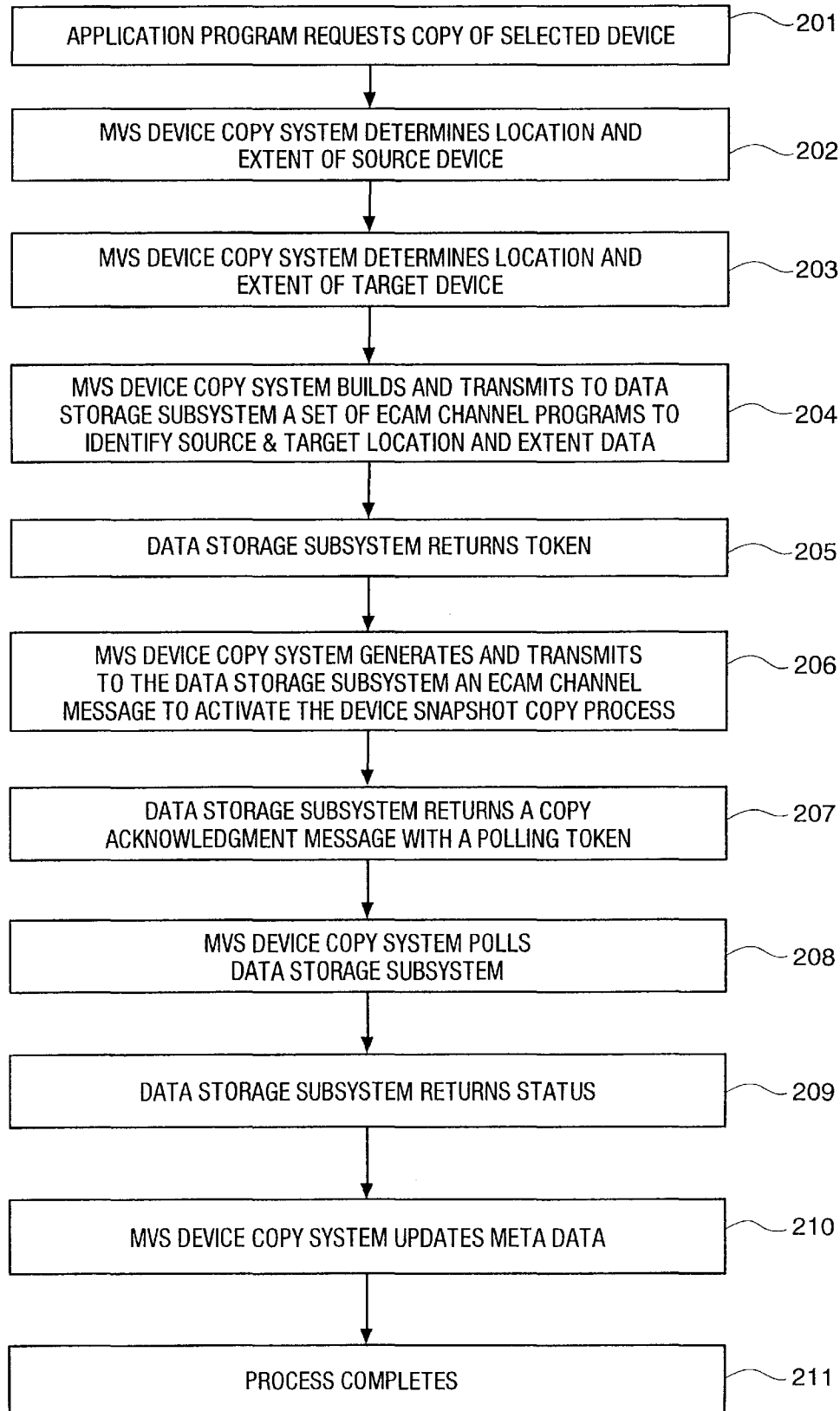

FIG. 1

**FIG. 2**

**MVS DEVICE BACKUP SYSTEM FOR A  
DATA PROCESSOR USING A DATA  
STORAGE SUBSYSTEM SNAPSHOT COPY  
CAPABILITY**

**CROSS REFERENCE TO RELATED  
APPLICATIONS**

This application is related to copending applications titled "System For Providing Write Notification During Data Set Copy" and "DASD File Copy System For A Data Processor Using A Data Storage Subsystem Snapshot Copy Capability", filed on the same date as the present invention, Ser. No. 08/843,544 (now U.S. Pat. No. 5,915,264) and Ser. No. 08/844,046 (now pending), respectively.

**FIELD OF THE INVENTION**

This invention relates to data storage subsystems, and, in particular, to an MVS device backup system which is resident on a data processor and which regulates the backup of an MVS device on to the virtual data storage devices of a data storage subsystem which is connected to the data processor. The MVS device backup system manages the designation of the source and target data storage volumes and activates the snapshot copy resources of the data storage subsystem to perform the device backup operation without the necessity of the data processor having to expend a significant amount of processing resources.

**PROBLEM**

It is a problem in the field of computer systems to efficiently create backup copies of the data sets of an MVS device, which backup copies represent a single point-in-time for all data resident on the source MVS device. In a typical computer system, data processors are connected to one or more data storage subsystems, which include disk drive memory systems. The data processors and their associated data storage subsystems therefore must manage the backup of data sets stored on the virtual volumes of the data storage subsystem in a manner that does not adversely impact the performance and efficiency of the data processor and which also ensures the integrity of the data.

The backup of device data in a traditional DASD data storage subsystem entails the data processor retrieving the device data from the data storage subsystem, then writing the retrieved device data to a designated backup data storage location in the data storage subsystem. In particular, as part of this process, device data backup utilities perform volume track level backup by executing a series of read and write channel programs. These channel programs read data from the data storage subsystem into memory on a data processor and then write the data back out to the backup data storage subsystem as a series channel programs from that data processor memory. This system is resource intensive, in that the data processor expends a significant amount of resources (CPU cycles) to achieve the device data backup operation. In addition, channel resources are needed to perform the data processor based device backup operation. Furthermore, two significant difficulties with data storage subsystems are the time required to make backup copies of device data and the need to maintain the consistency of the device data during the time it takes to make backup copies of the device data. This is a significant issue when a backup copy must be made of a large devices which may contain many devices or data bases which are the target of a single or common application programs.

Several further problems are encountered in the creation of backup copies. The creation of physical backup copies of

device data requires the expenditure of data processor, data channel, data storage subsystem and backup data storage device resources. In addition, the concurrent access to the device data may be hindered due to device request queuing.

This is necessitated by the requirement that the backup data represents a single point-in-time copy of the data for the entire source device.

An alternative to the data processor controlled device copy operation described above is the data storage subsystem snapshot copy operation described in U.S. Pat. No. 5,410,667. This snapshot copy system creates a duplicate device pointer in a virtual track directory in the data storage subsystem to reference a device that a data processor has requested the data storage subsystem to copy. This enables the data processor to access the device via two virtual addresses while only a single physical copy of the device resides in the data storage subsystem. The snapshot copy operation is effected without the involvement of the data processor, since it is managed solely within the data storage subsystem. However, the snapshot copy operation cannot be selected by the data processor, but is because it is solely within the purview of the data storage subsystem. In addition, the snapshot copy operation is not available for use in creating a backup copy of an MVS device.

**SOLUTION**

The above described problems are solved and a technical advance achieved in the field by the MVS device backup system of the present invention which functions to enable the data processor to manage the device backup function in a manner that minimizes the expenditure of data processor resources. This is accomplished by the MVS device backup system designating the source and destination device volumes and then activating the snapshot copy resources of the data storage subsystem to perform the device backup operation without the necessity of the data processor being involved in the execution details of the operation. In addition, the instantaneous creation of a backup copy of the device data maintains a point-in-time image of the device data from the initiation of the device backup process until a physical backup copy of the device data is available.

The implementation of the MVS device backup system is data processor based, yet the DASD volume device backup is performed without using data processor CPU resources to perform the actual movement of the device data. Thus, the traditional data reads to data processor memory and the write channel programs are not utilized to copy the device data from a source device location to a target (backup) device location. Instead, the MVS device backup system determines the source device volume on the data storage subsystem, the target device volume on the data storage subsystem and identifies the extents of both. The MVS device backup system then transmits data to the data storage subsystem, representative of the assignment of DASD full tracks from the source device location on the data storage subsystem as well as DASD full tracks from the target (backup) device location on the data storage subsystem. The data processor based MVS device backup system then uses Extended Channel Access Method (ECAM) channel programs to instruct the data storage subsystem to perform the MVS device backup operation using the data storage subsystem snapshot track pointer copy operations. Upon conclusion of the device backup operation by the data storage subsystem, the MVS device backup system updates the meta data required to complete the device backup operation. Meta data is the supporting volume and device structures, stored in the data processor, that identify the devices and maintain the device status.

This MVS device backup system is a significant departure from the prior art operation of data storage subsystems since it does not require the expenditure of a significant amount of the data processor resources. In addition, the existing data storage subsystem snapshot copy capability is used to enable the data processor to control the copying of device data to designated backup data storage locations.

#### BRIEF DESCRIPTION OF THE DRAWING

FIG. 1 illustrates in block diagram form the overall architecture of a data system which includes the MVS device backup system of the present invention; and

FIG. 2 illustrates in flow diagram form the operational steps taken by the MVS device backup system.

#### DETAILED DESCRIPTION

FIG. 1 illustrates in block diagram form the overall architecture of a computer system 1 that incorporates the MVS device backup system BS of the present invention. The computer system 1 includes at least one data processor 11 to which are connected at least one data storage subsystem (DSS) 3, 3' that contains at least one and likely a plurality of data storage devices DS1-DS4 for reading and writing data onto data storage media for use by the data processor 11.

The data storage subsystem 3, 3' comprises a dynamically mapped virtual device data storage subsystem which implements a plurality of virtual data storage devices. In the preferred embodiment of the invention disclosed herein, the data storage subsystem 3 comprises a disk drive array data storage subsystem, although any data storage technology can be used to implement the data storage subsystem 3. For the purpose of simplicity of description, the disk drive array data storage subsystem example is used herein.

#### Mapping Tables

The data storage subsystem 3 dynamically maps between three abstract layers: virtual, logical and physical. The virtual layer functions as a conventional large form factor disk drive memory. The logical layer functions as an array of storage units that are grouped into a plurality of redundancy groups. The physical layer functions as a plurality of individual small form factor disk drives. The data storage subsystem 3 effectuates the dynamic mapping of data among these abstract layers and controls the allocation and management of the actual space on the physical devices. These data storage management functions are performed in a manner that renders the operation of the data storage subsystem 3 transparent to the data processor 11, which perceives only the virtual image of the data storage subsystem 3. A virtual device is therefore an entity addressable by data processor 11, with data processor-controlled content and data processor-managed space allocation. In this system, the virtual device consists of a mapping of a large form factor disk drive image onto a plurality of small form factor disk drives which constitute at least one redundancy group within the disk drive array. The virtual to physical mapping is accomplished by the use of a Virtual Device Table (VDT) entry which represents the virtual device. The "realization" of the virtual device is the set of Virtual Track Directory (VTD) entries, associated with the VDT entry each of which VTD entries contains data indicative of the Virtual Track Instances, which are the physical storage locations in the disk drive array redundancy group that contain the data records. The data storage management functions are performed in a manner that renders the operation of the data storage subsystems 3 transparent to data processors 11.

#### Device Snapshot Copy Operation

As described in U.S. Pat. No. 5,410,667, the data storage subsystem 3 includes a device copy capability which is termed a "snapshot copy" operation. The device snapshot copy operation instantaneously creates a second instance of a selected device by merely generating a new pointer to reference the same physical memory location as the original reference pointer in the virtual track directory. In this fashion, by simply generating a new pointer referencing the same physical memory space, the device can be copied. A physical copy of the original device can later be written as a background process to a second memory location, if so desired. Alternatively, when one of the programs that can access the device writes data to or modifies the device in any way, the modified track is written to a new physical memory location and the corresponding address pointers are changed to reflect the new location of this rewritten portion of the device.

This apparatus therefore instantaneously copies the original device without the time penalty of having to copy the track to the data processor 11 and then write the track to a new physical memory location on the data storage subsystem 3 via data channel 21. For the purpose of enabling a program to simply access the track at a different virtual address, the use of this mechanism provides a significant time advantage. In this fashion, a track can be instantaneously copied by simply creating a new memory pointer and the actual physical copying of the track can take place as a background process without the involvement of the data processor 11.

#### Operation of MVS Device Backup System

FIG. 2 illustrates in flow diagram form the operation of the MVS device 10 backup system BS, as implemented in the system environment described above. The MVS device backup system BS is illustrated herein as a device management process using the snapshot track level subsystem copy facility which is extant on the data processor 11, although other implementations, such as merging the functionality of the MVS device backup system BS into the other software running on data processor 11, are possible. In operation, data processor 11 requests the creation of a backup copy of an MVS device at step 201, which MVS device comprises a plurality of volumes of data sets stored on a virtual device on a one (for example DSS 3) of the data storage subsystem connected to data processor 11. The MVS device backup system BS, in response to the receipt of a device backup request, which includes an identification of the selected (source) MVS device, locates the identified source MVS device at step 202 and serializes the device staging request. The MVS device backup system BS searches the DSCB entries of the Volume Table of Content (VTOC) available to the data processor 11 and executes device type queries where necessary to thereby determine the device characteristics of the identified source MVS device as designated by the data processor 11. However, the data storage subsystem 3 stores data for the data processor 11 in virtual volumes, a plurality of which are implemented in data storage subsystem 3, as for example 256 logical DASD volumes. Thus, the device location information obtained by the MVS device backup system BS comprises the data processor view of the data storage location in which the selected source MVS device is stored on data storage subsystem 3.

The MVS device backup system BS, in response to the receipt of a device backup request, also locates or allocates a target location for the storage of the copy of the selected source MVS device at step 203. The MVS device backup system BS searches the DSCB entries of the VTOC avail-

# Explore Litigation Insights

Docket Alarm provides insights to develop a more informed litigation strategy and the peace of mind of knowing you're on top of things.

## Real-Time Litigation Alerts



Keep your litigation team up-to-date with **real-time alerts** and advanced team management tools built for the enterprise, all while greatly reducing PACER spend.

Our comprehensive service means we can handle Federal, State, and Administrative courts across the country.

## Advanced Docket Research



With over 230 million records, Docket Alarm's cloud-native docket research platform finds what other services can't. Coverage includes Federal, State, plus PTAB, TTAB, ITC and NLRB decisions, all in one place.

Identify arguments that have been successful in the past with full text, pinpoint searching. Link to case law cited within any court document via Fastcase.

## Analytics At Your Fingertips



Learn what happened the last time a particular judge, opposing counsel or company faced cases similar to yours.

Advanced out-of-the-box PTAB and TTAB analytics are always at your fingertips.

## API

Docket Alarm offers a powerful API (application programming interface) to developers that want to integrate case filings into their apps.

## LAW FIRMS

Build custom dashboards for your attorneys and clients with live data direct from the court.

Automate many repetitive legal tasks like conflict checks, document management, and marketing.

## FINANCIAL INSTITUTIONS

Litigation and bankruptcy checks for companies and debtors.

## E-DISCOVERY AND LEGAL VENDORS

Sync your system to PACER to automate legal marketing.