



US005517488A

# United States Patent [19]

[11] Patent Number: 5,517,488

Miyazaki et al.

[45] Date of Patent: May 14, 1996

[54] **METHOD OF LOAD DISTRIBUTION FOR MESSAGE PROCESSING IN HOST SYSTEM IN LOCAL AREA NETWORK**

[75] Inventors: **Satoshi Miyazaki**, Yamato; **Kazuo Yagyu**, Hiratsuka; **Makoto Takahashi**, Yokohama; **Kazuo Orioka**, Chigasaki, all of Japan

[73] Assignee: **Hitachi, Ltd.**, Tokyo, Japan

[21] Appl. No.: **80,801**

[22] Filed: **Jun. 21, 1993**

[30] **Foreign Application Priority Data**

Jun. 23, 1992 [JP] Japan ..... 4-164544

[51] Int. Cl.<sup>6</sup> ..... **H04J 3/14**

[52] U.S. Cl. .... **370/16**; 370/60.1; 370/85.1; 370/94.1; 395/180; 395/181

[58] Field of Search ..... 370/16, 58.3, 60, 370/60.1, 94.1, 85.1; 379/2; 371/8.1, 8.2, 11.1, 11.2

[56] **References Cited**

**U.S. PATENT DOCUMENTS**

5,016,244 5/1991 Mussey, Jr. et al. .... 370/16

**FOREIGN PATENT DOCUMENTS**

1-123545 5/1989 Japan ..... H04L 11/00  
4-167841 6/1992 Japan ..... H04L 12/40

**OTHER PUBLICATIONS**

Comer, Douglas E. Internetworking with TCP/IP, vol. 1, Second Edition, Prentice-Hall, 1991, p. 63. (Japanese with English translation).

*Primary Examiner*—Douglas W. Olms  
*Assistant Examiner*—Russell W. Blum  
*Attorney, Agent, or Firm*—Fay, Sharpe, Beall, Fagan, Minnich & McKee

[57] **ABSTRACT**

An LAN system provided with a host system connected to an LAN through a plurality of LAN adapters, and a plurality of terminal systems for communicating with the host system through the LAN. A plurality of logical addresses for the host system are set correspondingly to physical addresses of the LAN adapters. One of the logical addresses is selected arbitrarily as a key (common) logical address. When the host system is to send a message to one of the terminal systems, the host system sets the key logical address of the host system as a source logical address included in the message, selects one of the LAN adapters and sends the message to the LAN through the selected LAN adapter. When one of the terminal systems is to send a message to the host system, the terminal system sets the key logical address of the host system as a destination logical address included in the message, sets the physical address of the LAN adapter corresponding to the key logical address as a destination physical address included in the message and sends the message to the LAN.

**11 Claims, 9 Drawing Sheets**

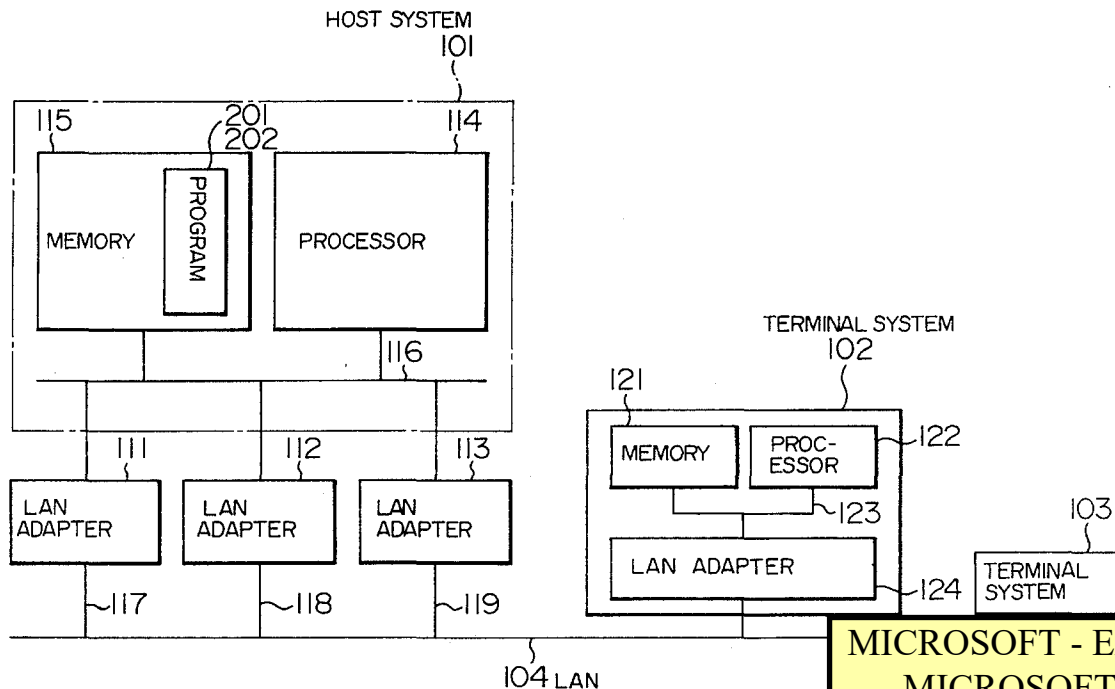

**MICROSOFT - EXHIBIT 1039  
MICROSOFT CORP. v.  
UNILOC 2017 LLC  
IPR2019-01026**

**Docket Alarm**  
Duplicate first page for exhibit labeling, per 37 C.F.R. § 42.63(d)(2)(ii).



[54] METHOD OF LOAD DISTRIBUTION FOR MESSAGE PROCESSING IN HOST SYSTEM IN LOCAL AREA NETWORK

[75] Inventors: Satoshi Miyazaki, Yamato; Kazuo Yagyu, Hiratsuka; Makoto Takahashi, Yokohama; Kazuo Orioka, Chigasaki, all of Japan

[73] Assignee: Hitachi, Ltd., Tokyo, Japan

[21] Appl. No.: 80,801

[22] Filed: Jun. 21, 1993

[30] Foreign Application Priority Data

Jun. 23, 1992 [JP] Japan ..... 4-164544

[51] Int. Cl.<sup>6</sup> ..... H04J 3/14

[52] U.S. Cl. .... 370/16; 370/60.1; 370/85.1; 370/94.1; 395/180; 395/181

[58] Field of Search ..... 370/16, 58.3, 60, 370/60.1, 94.1, 85.1; 379/2; 371/8.1, 8.2, 11.1, 11.2

[56] References Cited

U.S. PATENT DOCUMENTS

5,016,244 5/1991 Mussey, Jr. et al. .... 370/16

FOREIGN PATENT DOCUMENTS

1-123545 5/1989 Japan ..... H04L 11/00

4-167841 6/1992 Japan ..... H04L 12/40

OTHER PUBLICATIONS

Comer, Douglas E. Internetworking with TCP/IP, vol. 1, Second Edition, Prentice-Hall, 1991, p. 63. (Japanese with English translation).

Primary Examiner—Douglas W. Olms

Assistant Examiner—Russell W. Blum

Attorney, Agent, or Firm—Fay, Sharpe, Beall, Fagan, Minnich & McKee

[57] ABSTRACT

An LAN system provided with a host system connected to an LAN through a plurality of LAN adapters, and a plurality of terminal systems for communicating with the host system through the LAN. A plurality of logical addresses for the host system are set correspondingly to physical addresses of the LAN adapters. One of the logical addresses is selected arbitrarily as a key (common) logical address. When the host system is to send a message to one of the terminal systems, the host system sets the key logical address of the host system as a source logical address included in the message, selects one of the LAN adapters and sends the message to the LAN through the selected LAN adapter. When one of the terminal systems is to send a message to the host system, the terminal system sets the key logical address of the host system as a destination logical address included in the message, sets the physical address of the LAN adapter corresponding to the key logical address as a destination physical address included in the message and sends the message to the LAN.

11 Claims, 9 Drawing Sheets

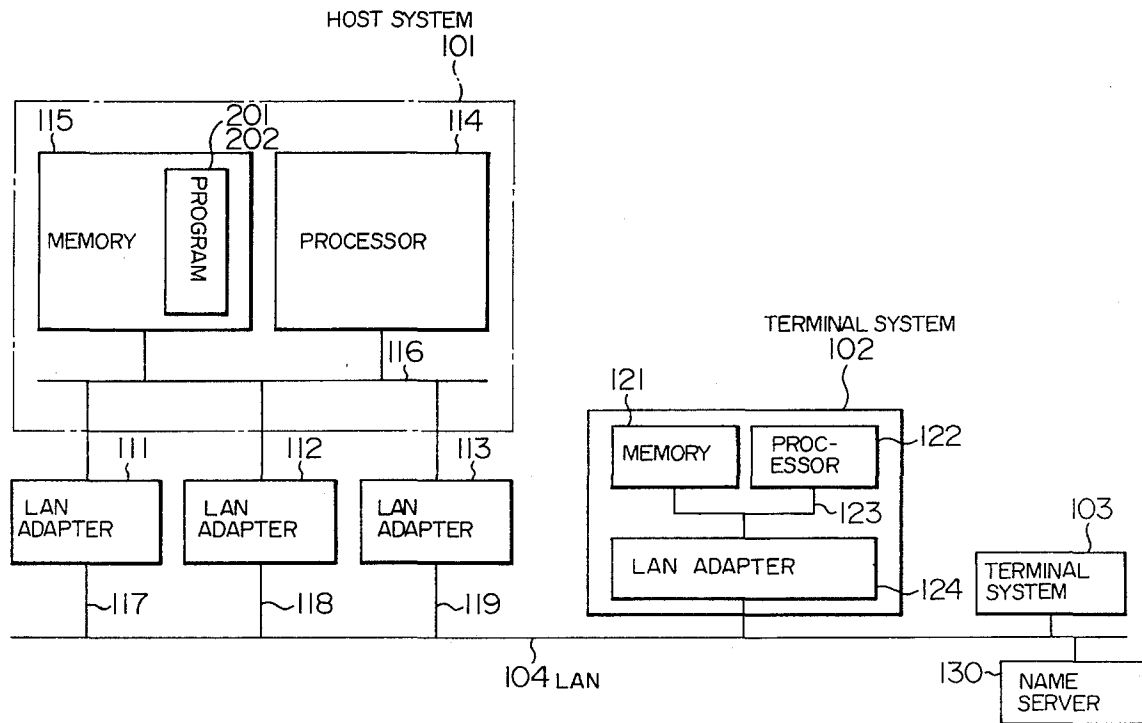

FIG. 1

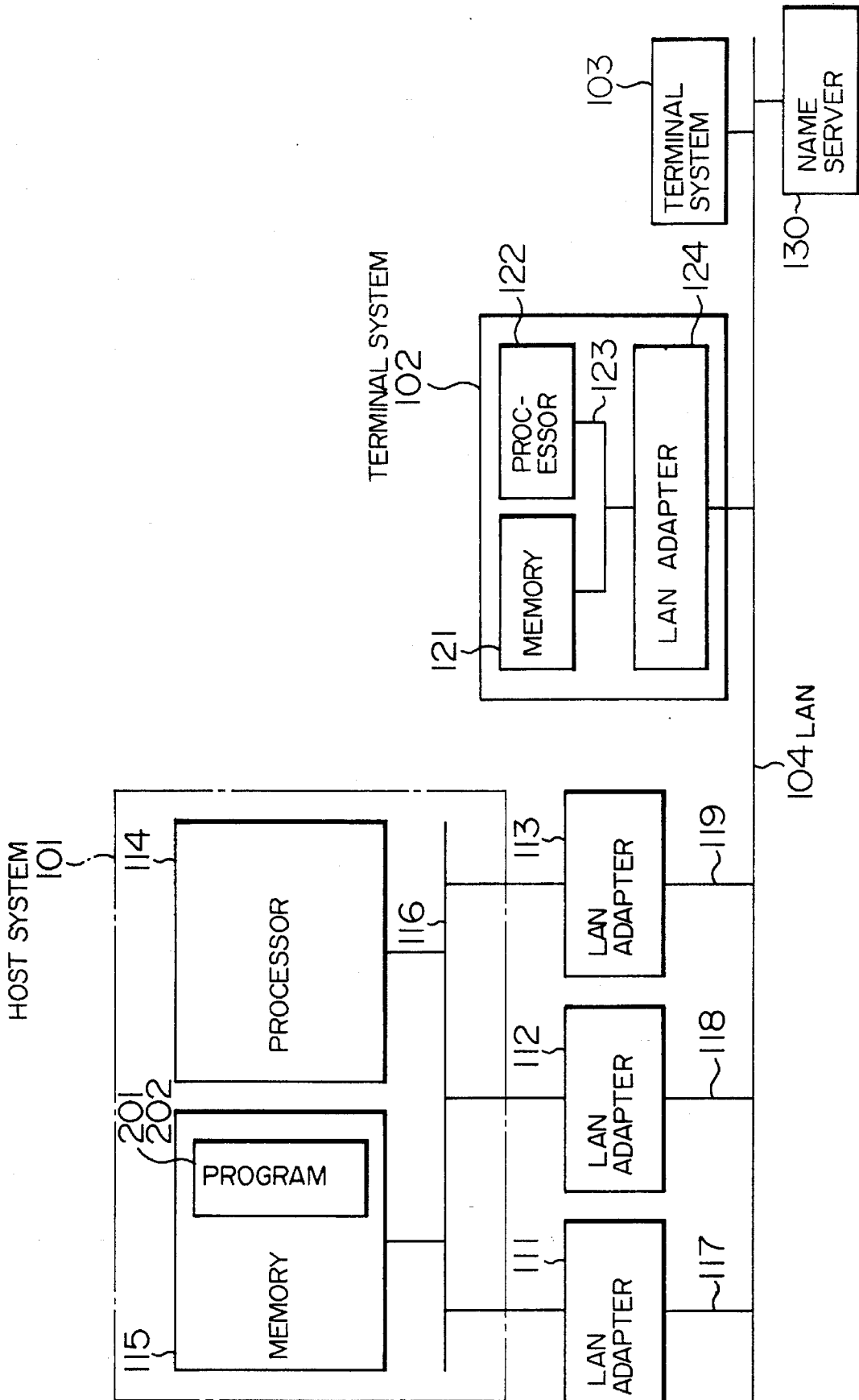
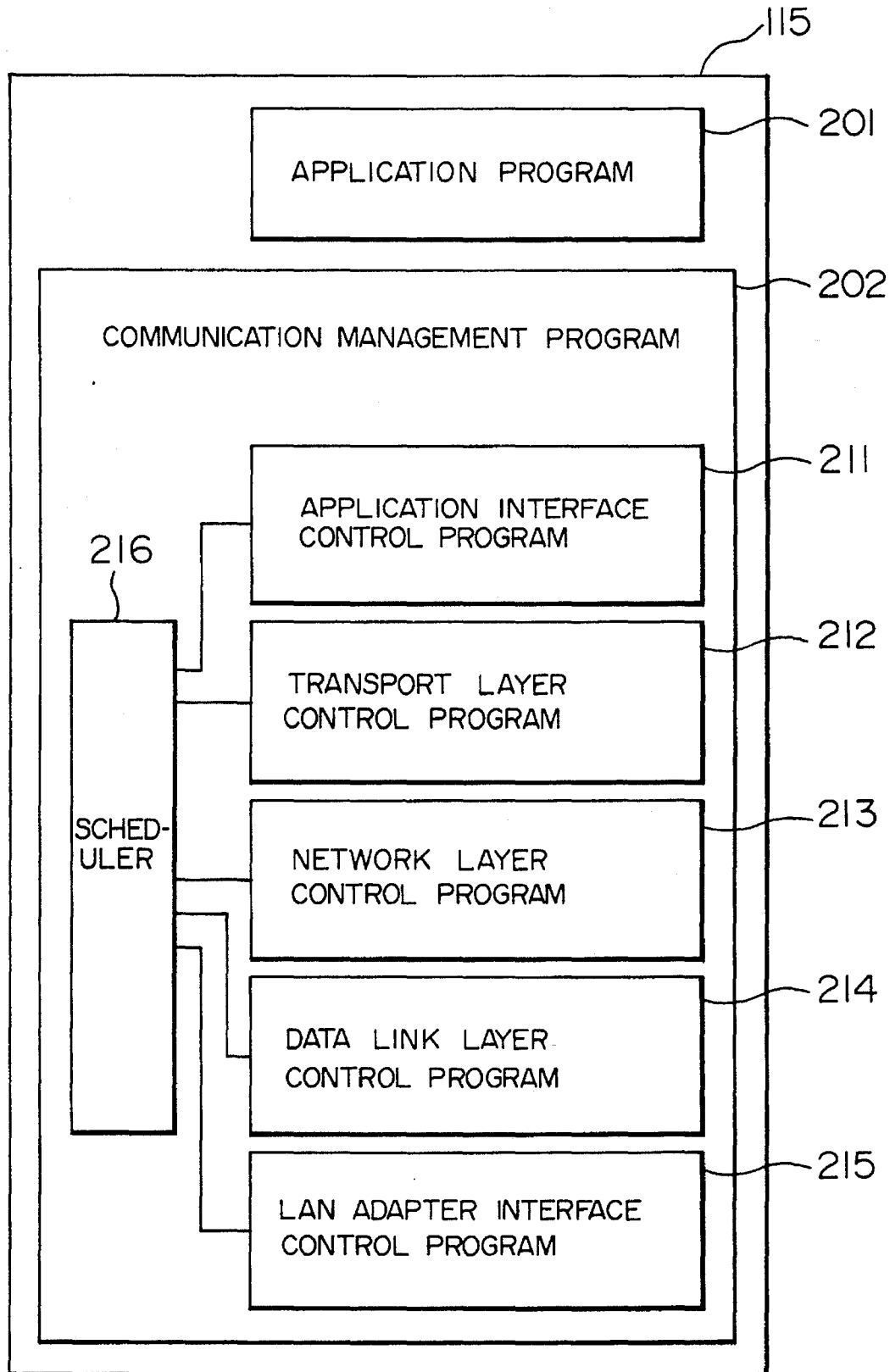

FIG. 2



**FIG. 3** HOST ADDRESS IN HOST SYSTEM

	PHYSICAL ADDRESS	LOGICAL ADDRESS
LAN ADAPTER 111	a	A
LAN ADAPTER 112	b	B
LAN ADAPTER 113	c	C

**FIG. 5** TERMINAL ADDRESS IN HOST SYSTEM

	PHYSICAL ADDRESS	LOGICAL ADDRESS
TERMINAL SYSTEM 102	d	D
TERMINAL SYSTEM 103	e	E

**FIG. 6A** TRANSMISSION DATA

DESTINATION PHYSICAL ADDRESS	SOURCE PHYSICAL ADDRESS	DESTINATION LOGICAL ADDRESS	SOURCE LOGICAL ADDRESS	DATA
a	d	A	D	

**FIG. 6B** TRANSMISSION DATA

DESTINATION PHYSICAL ADDRESS	SOURCE PHYSICAL ADDRESS	DESTINATION LOGICAL ADDRESS	SOURCE LOGICAL ADDRESS	DATA
d	a	D	A	

**FIG. 8** TABLE FOR TERMINAL SYSTEM 102

	PHYSICAL ADDRESS	LOGICAL ADDRESS
HOST SYSTEM	a	A
TERMINAL SYSTEM 103	e	E

# Explore Litigation Insights

Docket Alarm provides insights to develop a more informed litigation strategy and the peace of mind of knowing you're on top of things.

## Real-Time Litigation Alerts



Keep your litigation team up-to-date with **real-time alerts** and advanced team management tools built for the enterprise, all while greatly reducing PACER spend.

Our comprehensive service means we can handle Federal, State, and Administrative courts across the country.

## Advanced Docket Research



With over 230 million records, Docket Alarm's cloud-native docket research platform finds what other services can't. Coverage includes Federal, State, plus PTAB, TTAB, ITC and NLRB decisions, all in one place.

Identify arguments that have been successful in the past with full text, pinpoint searching. Link to case law cited within any court document via Fastcase.

## Analytics At Your Fingertips



Learn what happened the last time a particular judge, opposing counsel or company faced cases similar to yours.

Advanced out-of-the-box PTAB and TTAB analytics are always at your fingertips.

## API

Docket Alarm offers a powerful API (application programming interface) to developers that want to integrate case filings into their apps.

## LAW FIRMS

Build custom dashboards for your attorneys and clients with live data direct from the court.

Automate many repetitive legal tasks like conflict checks, document management, and marketing.

## FINANCIAL INSTITUTIONS

Litigation and bankruptcy checks for companies and debtors.

## E-DISCOVERY AND LEGAL VENDORS

Sync your system to PACER to automate legal marketing.