

(19) **United States**

(12) **Patent Application Publication** (10) **Pub. No.: US 2003/0172376 A1**

**Coffin, III**

(43) **Pub. Date: Sep. 11, 2003**

(54) **USER CONTROLLED TARGETED ADVERTISEMENT PLACEMENT FOR RECEIVER MODULES**

(52) **U.S. Cl. .... 725/22; 725/23; 705/14**

(75) **Inventor: Louis F. Coffin III, Mountain View, CA (US)**

(57) **ABSTRACT**

Correspondence Address:  
**RICK D. NYDEGGER  
WORKMAN, NYDEGGER & SEELEY  
1000 Eagle Gate Tower  
60 East South Temple  
Salt Lake City, UT 84111 (US)**

Systems and methods for displaying broadcast programming and generating points for viewing advertising content selected by the viewer. The systems and methods store one or more viewer attributes unique to the viewer. These attributes define one or more categories of advertising content to be displayed to the viewer and the points earned from viewing displayed advertising content. The viewer defines one or more categories of advertising to be displayed and the methods and systems select advertising content, either via an operator module delivering or the receiver module receiving the advertising content, having a category identifier matching the category selected by the viewer. This advertising content is displayed to the viewer and the viewer's points are updated to reflect that the viewer watched all or a portion of the advertising content.

(73) **Assignee: Microsoft Corporation**

(21) **Appl. No.: 10/096,022**

(22) **Filed: Mar. 11, 2002**

**Publication Classification**

(51) **Int. Cl.<sup>7</sup> ..... G06F 17/60; H04N 7/16; H04H 9/00**

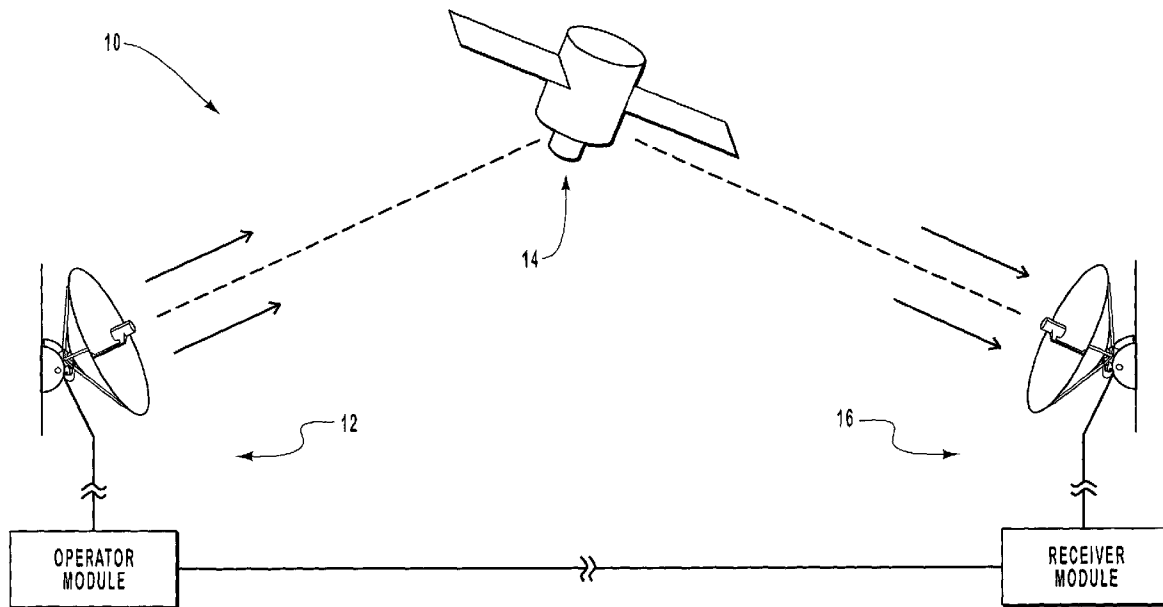

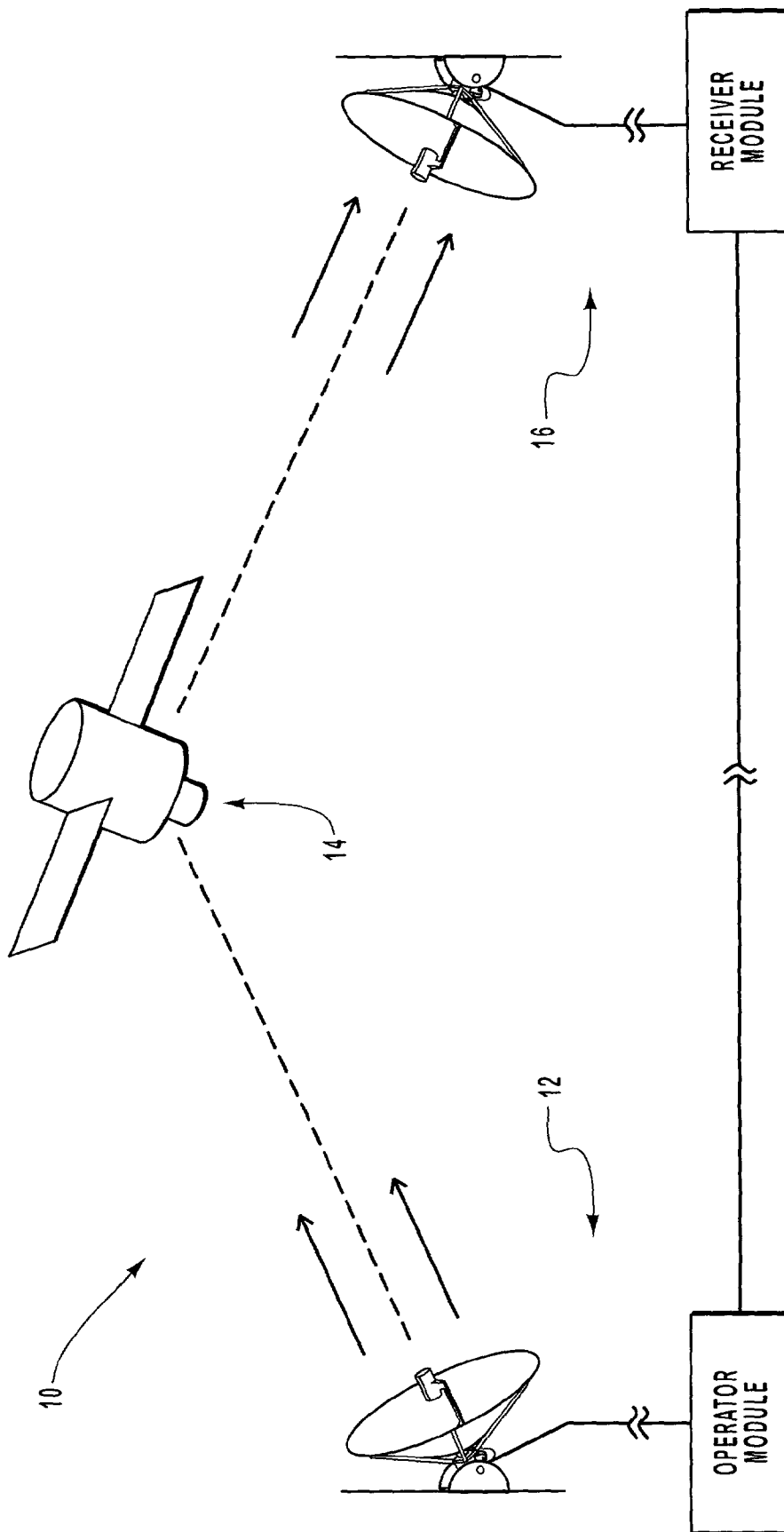

Fig. 1

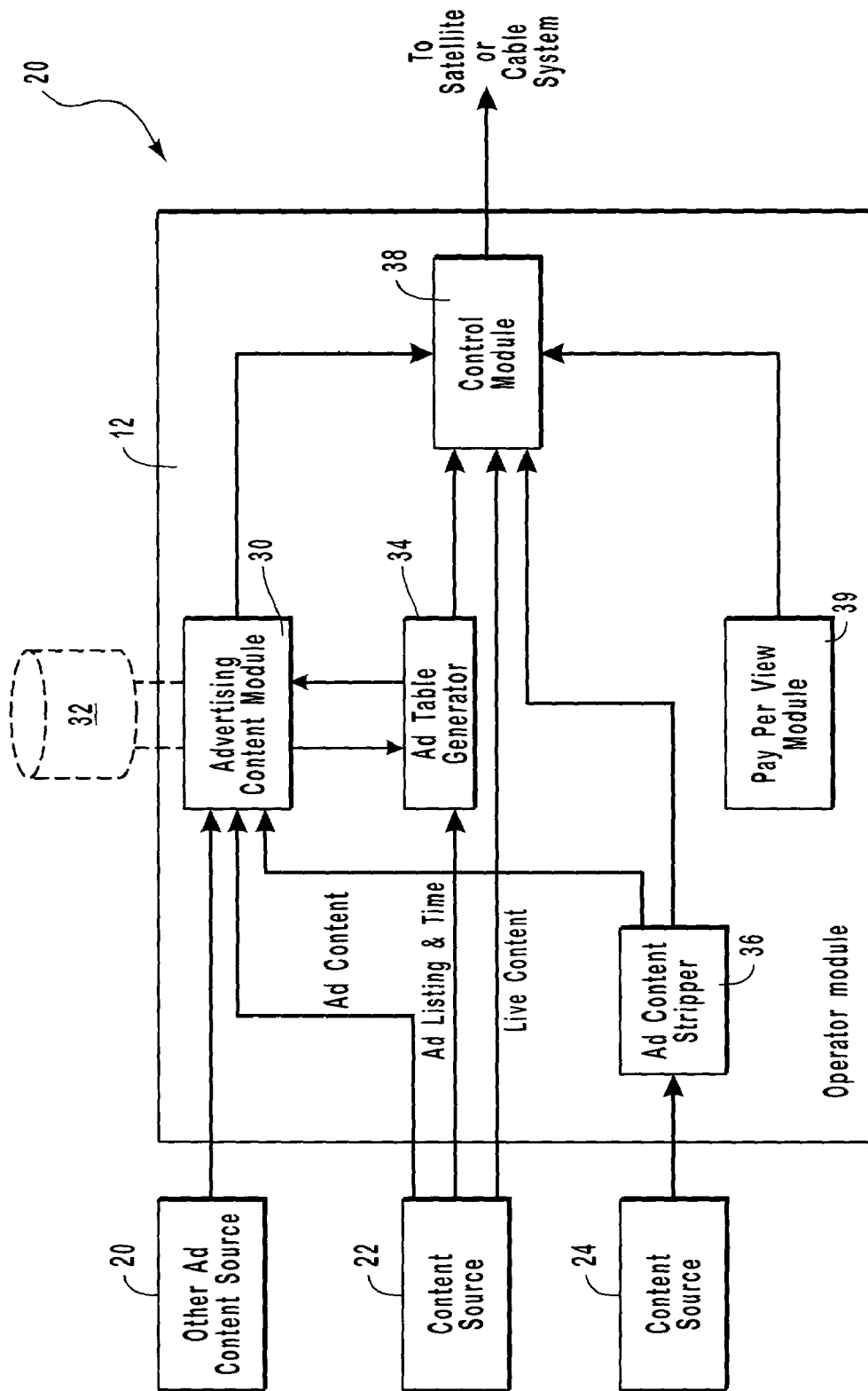

Fig. 2

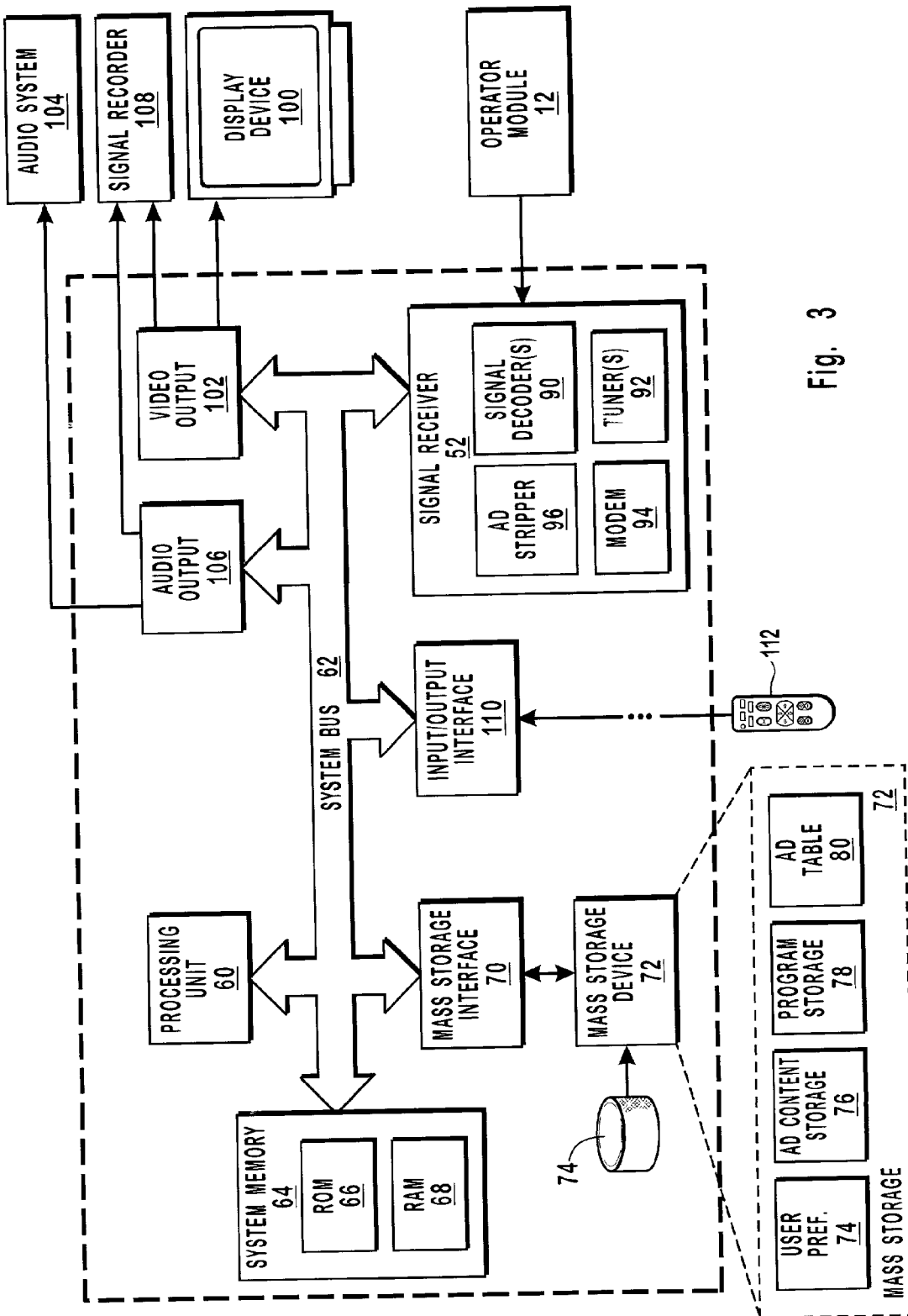

Fig. 3

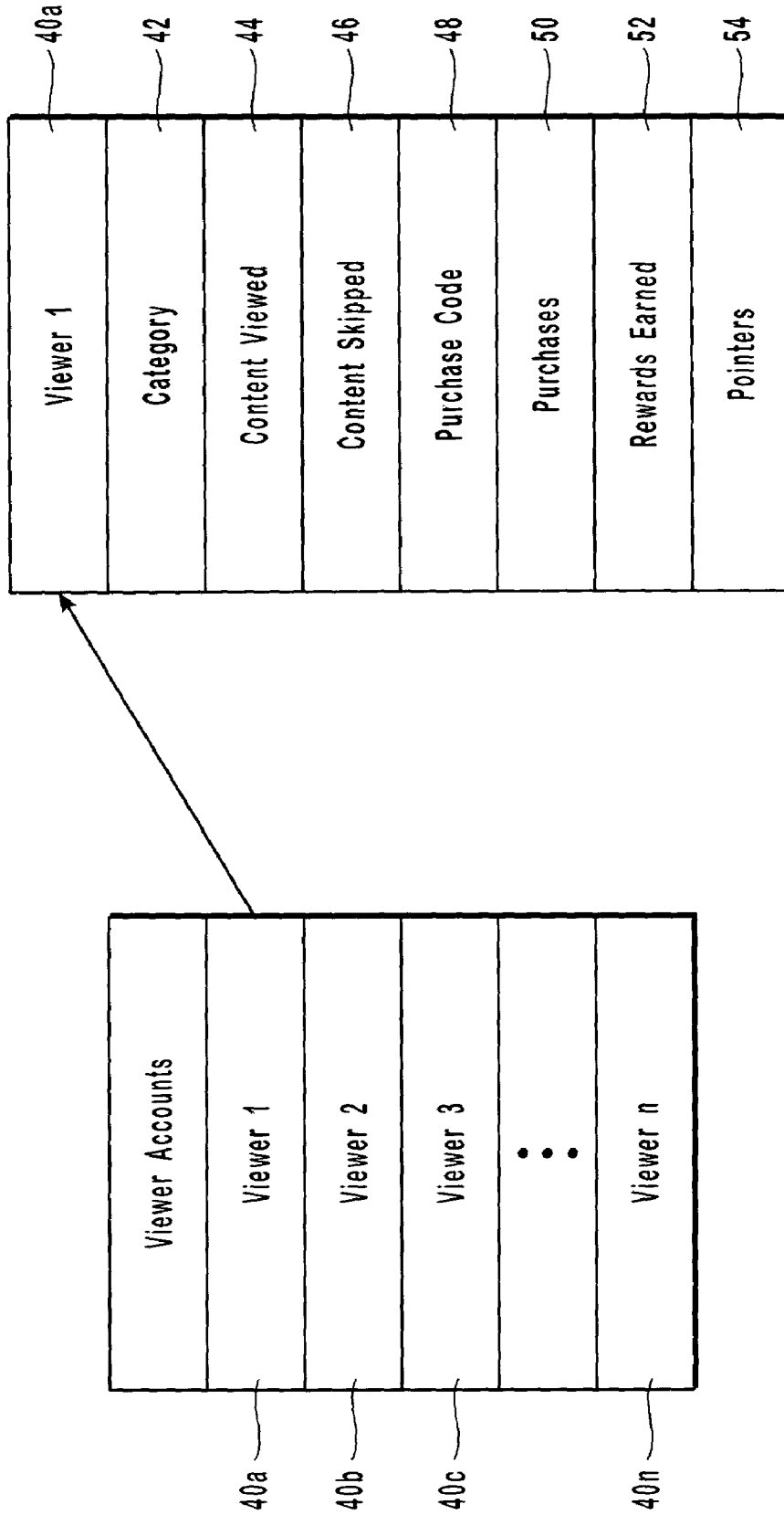

Fig. 4

# Explore Litigation Insights

Docket Alarm provides insights to develop a more informed litigation strategy and the peace of mind of knowing you're on top of things.

## Real-Time Litigation Alerts



Keep your litigation team up-to-date with **real-time alerts** and advanced team management tools built for the enterprise, all while greatly reducing PACER spend.

Our comprehensive service means we can handle Federal, State, and Administrative courts across the country.

## Advanced Docket Research



With over 230 million records, Docket Alarm's cloud-native docket research platform finds what other services can't. Coverage includes Federal, State, plus PTAB, TTAB, ITC and NLRB decisions, all in one place.

Identify arguments that have been successful in the past with full text, pinpoint searching. Link to case law cited within any court document via Fastcase.

## Analytics At Your Fingertips



Learn what happened the last time a particular judge, opposing counsel or company faced cases similar to yours.

Advanced out-of-the-box PTAB and TTAB analytics are always at your fingertips.

## API

Docket Alarm offers a powerful API (application programming interface) to developers that want to integrate case filings into their apps.

## LAW FIRMS

Build custom dashboards for your attorneys and clients with live data direct from the court.

Automate many repetitive legal tasks like conflict checks, document management, and marketing.

## FINANCIAL INSTITUTIONS

Litigation and bankruptcy checks for companies and debtors.

## E-DISCOVERY AND LEGAL VENDORS

Sync your system to PACER to automate legal marketing.