



(22) Date de dépôt/Filing Date: 2000/09/29

(41) Mise à la disp. pub./Open to Public Insp.: 2002/03/29

(45) Date de délivrance/Issue Date: 2004/04/06

(51) Cl.Int.⁷/Int.Cl.⁷ H04N 7/173, H04L 12/16

(72) Inventeurs/Inventors:
CAMERON, ALLAN B., CA;
JONES, IAN K., CA;
SWANSBURG, DARREN B., CA;
ALSTON, DAVID J., CA;
HIGGINS, SEAN G., CA;
FURLONG, JEFF L., CA

(73) Propriétaire/Owner:
IMAGICTV INC., CA

(74) Agent: CASSAN MACLEAN

(54) Titre : SYSTEME NUMERIQUE A APPLICATIONS SUR DEMANDE PERMETTANT LA DIFFUSION INTERACTIVE PAR TELEVISION/MULTIMEDIA/INTERNET

(54) Title: DIGITAL INTERACTIVE DELIVERY SYSTEM FOR TV/MULTIMEDIA/INTERNET WITH ON-DEMAND APPLICATIONS

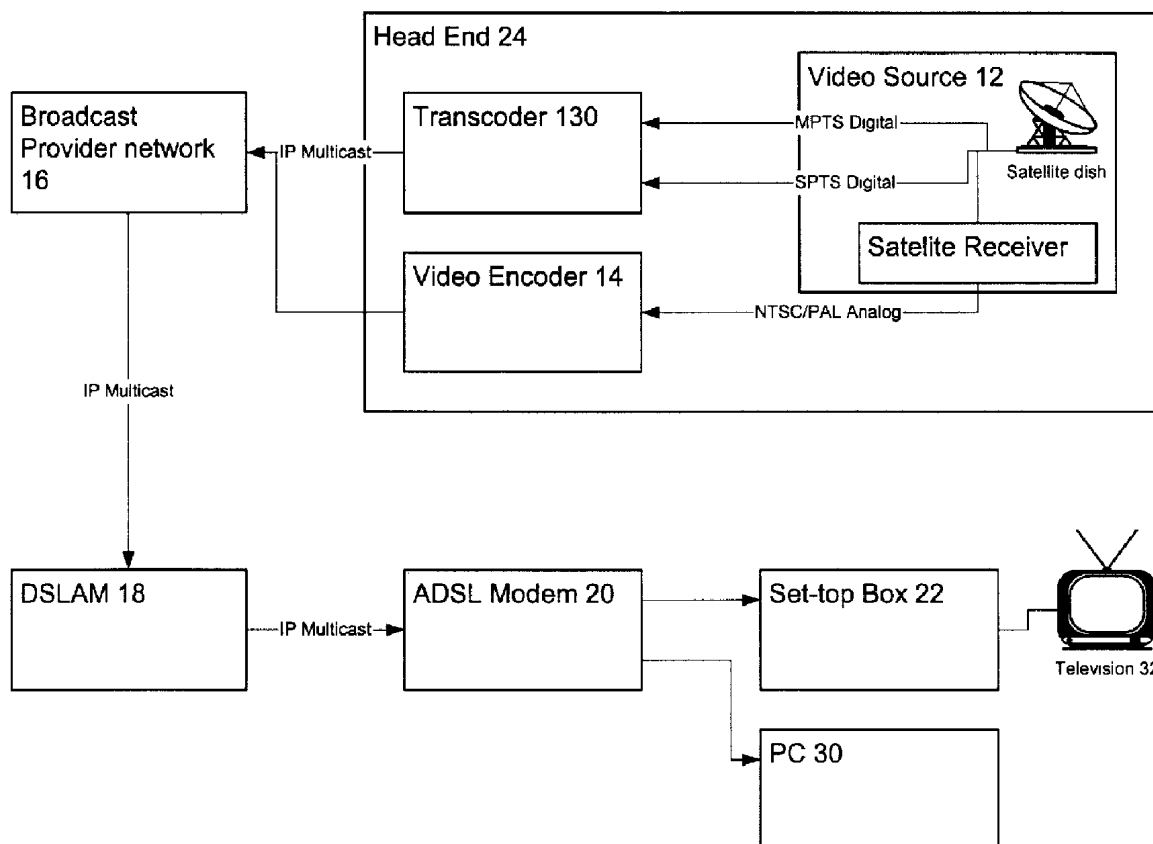

(57) Abrégé/Abstract:

This invention relates to a system for interactive on-demand delivery of multimedia using a multicast broadband backbone

(57) **Abrégé(suite)/Abstract(continued):**

network transmitting IP- configured digital multimedia (e.g. television) signals. More particularly the on-demand system provides, inter alia, a Virtual Digital Video Recorder functionality. A system manager provides interactive access to the multimedia signals by a subscriber through either a decoder in a set top box (connected to a television) or a decoder in a computer (connected to a monitor) configured for converting the IP format signal into a format for display on the television or monitor. A central multimedia storage means is located within the network and remote from the subscriber for storing multimedia content. An on-demand component is configured for receiving a deliver request from a subscriber for the stored content, for locating the requested multimedia content from the storage means and for delivering the requested multimedia content for display on the television or monitor. The multimedia content is stored in the storage means in a format configured for locating same in response to a deliver request. An interactive program guide (IPG) may provide access to the multimedia signals and the multimedia signals are transmitted through the network according to scheduling corresponding to the interactive program guide. The on-demand component receives a record request (which includes broadcast channel and time information identifying the multimedia content and may utilize the IPG) from a subscriber and stores the multimedia content in response to the record request.

ABSTRACT

5 This invention relates to a system for interactive on-demand delivery of
multimedia using a multicast broadband backbone network transmitting IP-configured
digital multimedia (e.g. television) signals. More particularly the on-demand system
provides , inter alia, a Virtual Digital Video Recorder functionality. A system manager
provides interactive access to the multimedia signals by a subscriber through either a
10 decoder in a set top box (connected to a television) or a decoder in a computer
(connected to a monitor) configured for converting the IP format signal into a format
for display on the television or monitor. A central multimedia storage means is located
within the network and remote from the subscriber for storing multimedia content. An
on-demand component is configured for receiving a deliver request from a subscriber
15 for the stored content, for locating the requested multimedia content from the storage
means and for delivering the requested multimedia content for display on the
television or monitor. The multimedia content is stored in the storage means in a
format configured for locating same in response to a deliver request. An interactive
program guide (IPG) may provide access to the multimedia signals and the multimedia
20 signals are transmitted through the network according to scheduling corresponding to
the interactive program guide. The on-demand component receives a record request
(which includes broadcast channel and time information identifying the multimedia
content and may utilize the IPG) from a subscriber and stores the multimedia content
in response to the record request.

DIGITAL INTERACTIVE DELIVERY SYSTEM FOR TV/MULTIMEDIA/INTERNET WITH ON-DEMAND APPLICATIONS

5 Technical Field

This invention relates generally to a system for the delivery of IP-configured digital multimedia (e.g. television) signals to a subscriber (consumer) using multicast transmissions over a broadband network and, more particularly, to a system for interactive on-demand delivery of multimedia providing, inter alia, a Virtual Digital
10 Video Recorder functionality.

Background

With the proliferation of TV broadcast providers delivering regular programming as well as specialty services, such as pay per view and first run movies, TV viewers
15 are frequently faced with scheduling problems in order to view their favorite programs. The scheduling problem is even more severe in a typical household having one television with several potential viewers each having their own viewing preferences. The known video cassette and digital video recorders (VCRs and DVRs) which attach to televisions enable consumers to record a television program on a current or
20 scheduled basis but they do not permit one to record two programs simultaneously and, further, have associated with them many inconveniences such as the need to have a usable recording medium (i.e. tape or disc) at hand at the time one wishes to record a program and considerable operational time and know-how with respect to use of the hardware which has become more complex with the addition of pre-
25 programming features which utilize program codes.

TV broadcasts are currently delivered through service providers such as cable companies, and satellite operators and, of course, direct broadcast reception via traditional antennas and rabbit ears. Conventional cable service requires the
30 installation of a dedicated cable to the subscriber's residence. Satellite broadcast service requires that the user have a satellite dish located on or somewhere close to

their residence. Antennas and rabbit ears are generally limited to the reception of local programming. Additionally, program delivery via all of these services is at the convenience of the service provider or broadcaster and, hence, the user or subscriber must arrange his or her schedule to coincide with program availability.

5

It is well known that the purchase of personal computers by homeowners has increased dramatically in recent years. Previously, these computers were used primarily for word processing, accounting and other record keeping purposes and also for Web surfing and email using modems and conventional telephone service for connecting to the Internet. Frequently, however, these modems have a low baud rate making the transfer of data, particularly graphics, unacceptably slow. More recently, however, with the development of Digital Subscriber Line (DSL) technologies such as ADSL an expanded scope of broadband capacity exists for the copper wire (twisted pairs) at the user-end of the telecommunications network and this capacity may be used to provide enriched communications services to consumers including multimedia such as television and video.

10

15

With the increased availability of broadband backbone and delivery networks, and increased usage of PCs by consumers, an increasing demand is evolving for on-demand multimedia services which enable consumers to plan their entertainment to their own schedule and interests rather than tailor their entertainment viewing habits to a service provider's broadcast schedule. Moreover, there is a need to overcome the inherent limitations presented by the usual home installations of VCRs and DVRs connected to television sets. The fixed hardware of such machines is inherently time-limited and any upgrades or design changes to implement new services must be done physically either by installing new hardware/software packages in the machine or, more likely, by buying a new machine to replace an outdated one (causing much expense to the consumer). Further, from the perspective of consumers, using VCR and DVR machines to record and view broadcast multimedia is undesirably machine-limited in that one must have a separate VCR/DVR machine connected to its own

20

25

30

Explore Litigation Insights

Docket Alarm provides insights to develop a more informed litigation strategy and the peace of mind of knowing you're on top of things.

Real-Time Litigation Alerts



Keep your litigation team up-to-date with **real-time alerts** and advanced team management tools built for the enterprise, all while greatly reducing PACER spend.

Our comprehensive service means we can handle Federal, State, and Administrative courts across the country.

Advanced Docket Research



With over 230 million records, Docket Alarm's cloud-native docket research platform finds what other services can't. Coverage includes Federal, State, plus PTAB, TTAB, ITC and NLRB decisions, all in one place.

Identify arguments that have been successful in the past with full text, pinpoint searching. Link to case law cited within any court document via Fastcase.

Analytics At Your Fingertips



Learn what happened the last time a particular judge, opposing counsel or company faced cases similar to yours.

Advanced out-of-the-box PTAB and TTAB analytics are always at your fingertips.

API

Docket Alarm offers a powerful API (application programming interface) to developers that want to integrate case filings into their apps.

LAW FIRMS

Build custom dashboards for your attorneys and clients with live data direct from the court.

Automate many repetitive legal tasks like conflict checks, document management, and marketing.

FINANCIAL INSTITUTIONS

Litigation and bankruptcy checks for companies and debtors.

E-DISCOVERY AND LEGAL VENDORS

Sync your system to PACER to automate legal marketing.