



TRANSPERFECT

City of New York, State of New York, County of New York

I, Anders Ekholm, hereby certify that the document, “**DE19710546 Herfet**” is, to the best of my knowledge and belief, a true and accurate translation from German into English.

I declare under penalty of perjury under the laws of the United States of America that the foregoing is true and correct.

Anders Ekholm

Sworn to before me this  
November 8, 2018

Signature, Notary Public



Stamp, Notary Public

Apple Ex. 1014  
Apple Inc. v. Firstface Co., Ltd.  
IPR2019-01011

LANGUAGE AND TECHNOLOGY SOLUTIONS FOR GLOBAL BUSINESS

[barcode]

(19) FEDERAL REPUBLIC  
OF GERMANY



GERMAN PATENT  
OFFICE

(12) **Patent Application**  
(10) **DE 197 10 546 A1**

(21) Reference Number: 197 10 546.7  
(22) Filing Date: 03/14/1997  
(43) Publication Date: 09/17/1998

(51) Int.Cl.6:  
**G 07 C 9/00**  
H 04 M 1/66  
H 04 L 9/32  
H 04 N 7/173

DE 197 10 546 A1

(71) Applicant:  
Grundig AG, 90762 Fürth, DE

(72) Inventor:  
Herfet, Thorsten, Dr. Ing., 90518 Altdorf, DE

(56) Citations:  
DE 93 04 488 U1

**The following statements are derived from the documents submitted by the applicant**

A request for examination in accordance with § 44 Patent Law has been filed

(54) Authentication at multimedia terminals by electronic fingerprint

(57) The invention relates to a terminal for participating in services, which are subject to an access authorization. As a key for activating the access to such services, the invention proposes that the electronic fingerprint of a user is evaluated by the terminal and compared to fingerprints of a database stored in said terminal. In an advantageous embodiment, the receiving unit for receiving the fingerprint is integrated in the on/off switch of the terminal.

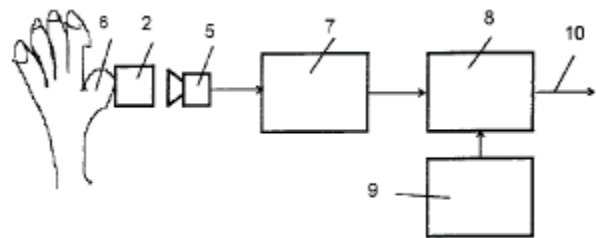

DE 197 10 546 A1

## Description

The invention relates to a terminal for participating in services, which are subject to an access authorization, with means for activating and deactivating the access authorization.

Such a terminal is used in the field of information technology, for example; in particular for consumer electronics. The terminal, for example a so-called set-top box or an appropriately equipped television set, is capable of participating in fee-based, possibly also interactive, services. Such fee-based services can either be billed via a chip card or, for example, electronically via a telephone network that can be coupled to the terminal.

The invention is based on the object of specifying a terminal of the aforementioned type, in which an authentication of the user is carried out in a simple manner.

This object is achieved in a terminal of the aforementioned type, in that the means for activating and/or deactivating the access authorization comprises a camera for recording the fingerprint of a user and a comparison device for comparing the recorded fingerprint with a fingerprint stored in a data memory.

A personal identification number (PIN) is fraught with a variety of disadvantages. A PIN can be forgotten, or, in the case of a chip card, said chip card can be lost, which opens the possibility of misuse by an unauthorized user. In contrast, in the present invention, the access authorization is activated and/or deactivated with the aid of an image recording unit, which records the fingerprint of the user and compares it with one or more fingerprints of authorized users stored in the terminal. On the one hand, this eliminates the additional burden of a chip card; the use of which is cumbersome and which can also be lost. Also, compared with a PIN, there is the advantage that the fingerprint is always available and misuse can be excluded completely.

A particularly advantageous embodiment consists in that the image recording unit is disposed in the region of an on/off switch of the terminal. This results in an automatic activation of services with access authorization when the respective on/off switch of the terminal is actuated. There is therefore no additional effort for the user.

Management of different users or groups of users is ensured in that the terminal comprises a display device which is provided for displaying and managing authorized users. This enables a simple management of user groups, in which, for example, children are denied access to adult channels.

Advantageous applications for the terminal are, for example, that the terminal is a reception device for receiving television signals, a multimedia terminal, a video recorder or a telephone device.

The invention is explained in more detail in the following on the basis of the design examples shown in the figures.

The figures show:

**Fig. 1** a television set having an on/off device with fingerprint recognition,

**Fig. 2** a block diagram for an automatic authentication process by means of a fingerprint,

**Fig. 3** a telephone device with electronic fingerprint recognition.

The television set shown in **Fig. 1** is provided for the reception of services with access authorization, for example fee-based television channels. With respect to its basic design, the television set shown in **Fig. 1** substantially corresponds to a conventional television set. The television set **1** comprises a screen **3** and an operating unit **4** with an integrated on/off device **2**. An image recording unit, which detects the fingerprint of a user when the television set **1** is switched on and compares it with a fingerprint stored in the television set, is provided in the region of the on/off device **2**.

With the aid of the television receiver shown in **Fig. 1**, it is thus possible to obtain access authorization to fee-based services solely by switching the set on, i.e. by actuating the on/off switch, as long as the fingerprint of the user matches the fingerprints stored in the television receiver. If the television reception device **1** is used by multiple users, a definition of different user groups can be specified during the installation of the television device **1**. Such a management of the user groups can be achieved with the aid of the display device **3**, i.e. the screen, on which the assignment of the individual fingerprints to different user groups can be carried out in a menu-controlled manner by means of the operating unit **4**, or by means of an associated remote control **20**. For example, a user group for children can be defined for the user group management, for which access to specific adult channels or specific violent shows is prohibited, while fully authorized users have full access, also to the services subject to an access authorization. Non-identifiable users, for example, then only have access to services that are not fee-based. With the aid of the television set shown in **Fig. 1**, it is thus possible for a corresponding access authorization to take place solely by the respective user switching on the set. In contrast to a chip card, for example, such a terminal thus makes a certain amount of expansion of the user database possible. The access of family members can be adapted to the respective requirements, for example, without the need to request a modification of the card authorization from the corresponding service provider.

**Fig. 2** shows a block diagram for automatic authentication by means of an electronic fingerprint, as can be used, for example, in connection with the television reception device illustrated in **Fig. 1**. The block diagram consists of an on/off switch **2**, behind which an image recording unit **5** is disposed. The image recording unit **5** serves to record the fingerprint **6** of a user during the switch-on process. The signals of the image recording unit **5** are sent to a signal processing device **7**, which, for example, binarizes the recorded signals and sends them to a comparison device **8** (correlation device). The comparison device **8** compares the signals provided by the signal processing device with signals of a fingerprint stored in a memory **9**. One respective control signal **10**, which triggers or does not trigger an approval for a service with an access authorization, is then present at the output of the comparison device **8**.

The on/off device **2** is coupled to the image recording unit **5** as a switch with a large surface area, for example. The image recording unit **5** can be designed as a miniature

camera or as a CCD surface sensor with a corresponding control. At the moment when the set is switched on, the fingerprint **6** of the user is recorded and subsequently compared to the database (= memory **9**), wherein a signal preprocessing, in the simplest case a binarization, and a correlator circuit in the form of the comparison device **8** are needed to carry out the comparison. The authentication illustrated in **Fig. 2** does not require any additional means such as chip cards. This significantly reduces the risk of misuse by loss or theft, even within a family. There is instead a direct relationship between use, i.e. switching on/off, and authentication. When the terminal is not in use for an extended period of time, e.g. in standby mode, the authentication can be reset automatically; i.e. in this case the activation of services with access authorization is only possible after a renewed switch-on process.

The authentication described in **Fig. 1** and **2** can be implemented in any type of multimedia terminal, in which an access authorization to specific services is required and the terminal is at the same time activated by switching on the device. These are essentially TV reception devices, e.g. in the form of satellite receivers, and video recorders for playing back programs or services. However, as will be explained in more detail with reference to the design example shown in **Fig. 3**, the invention is not limited to this field.

**Fig. 3** shows a further design example of a terminal according to the invention. The terminal in **Fig. 3** is a mobile telephone **16**, which comprises the usual components necessary for using and operating the telephone. The mobile radio device **16** therefore comprises an operating unit **12**, an on/off switch **13**, as well as a microphone **15**, a loudspeaker **16** and a display device **11**.

The mobile telephone **16** shown in **Fig. 3** contains the same functional units as a conventional mobile radio device. Only for access authorization to the respective radio services, the radio device comprises an automatic authentication which is disposed in the region of the on/off switch **13** and incorporates the mode of operation explained in the context of **Fig. 2**.

With the aid of the invention it is therefore possible, also in the context of a mobile telephone, to forgo the use of an authorization card, possibly with a PIN, without increasing the risk of misuse.

Claims

1. Terminal **(1)** for participating in services, which are subject to an access authorization, with means **(5, 7, 8, 9, 10)** for activating the access authorization, **characterized in that** the means **(5, 7, 8, 9, 10)** for activating the access authorization comprise an image recording unit **(5)** for recording the fingerprint **(6)** of a user and a comparison device **(8)** for comparing the recorded fingerprint **(6)** with a fingerprint stored in a memory **(9)**.
2. Terminal according to Claim 1, characterized in that the camera **(5)** is disposed in the region of an on/off switch **(2)** of the terminal **(1)**.
3. Terminal according to any one of Claims 1 or 2, characterized in that the terminal **(1)** comprises a

display device **(3)** which is provided for displaying and managing authorized users.  
 4. Terminal according to any one of Claims 1-3, characterized in that the terminal **(1)** is a reception device for receiving television signals, a multimedia terminal, a video recorder or a telephone device **(16)**.

---

Hereto 1 page of drawings

---

5  
10  
15  
20  
25  
30  
35  
40  
45  
50  
55  
60

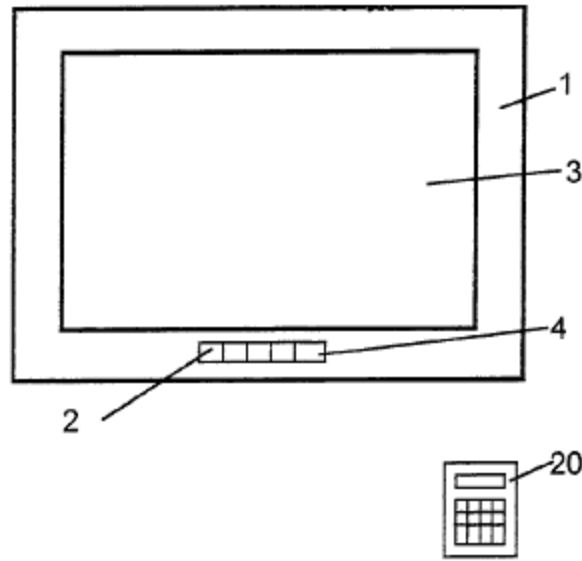

Fig. 1

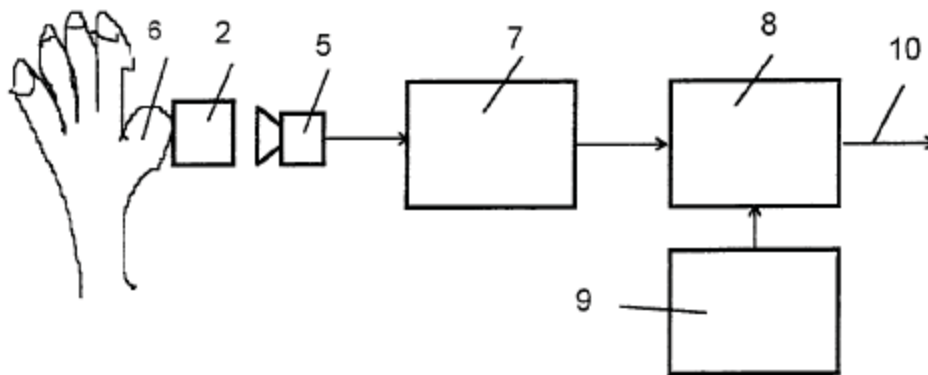

Fig. 2

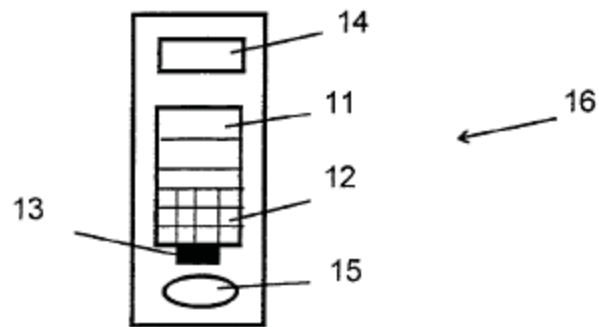

Fig. 3

# Explore Litigation Insights

Docket Alarm provides insights to develop a more informed litigation strategy and the peace of mind of knowing you're on top of things.

## Real-Time Litigation Alerts



Keep your litigation team up-to-date with **real-time alerts** and advanced team management tools built for the enterprise, all while greatly reducing PACER spend.

Our comprehensive service means we can handle Federal, State, and Administrative courts across the country.

## Advanced Docket Research



With over 230 million records, Docket Alarm's cloud-native docket research platform finds what other services can't. Coverage includes Federal, State, plus PTAB, TTAB, ITC and NLRB decisions, all in one place.

Identify arguments that have been successful in the past with full text, pinpoint searching. Link to case law cited within any court document via Fastcase.

## Analytics At Your Fingertips



Learn what happened the last time a particular judge, opposing counsel or company faced cases similar to yours.

Advanced out-of-the-box PTAB and TTAB analytics are always at your fingertips.

## API

Docket Alarm offers a powerful API (application programming interface) to developers that want to integrate case filings into their apps.

## LAW FIRMS

Build custom dashboards for your attorneys and clients with live data direct from the court.

Automate many repetitive legal tasks like conflict checks, document management, and marketing.

## FINANCIAL INSTITUTIONS

Litigation and bankruptcy checks for companies and debtors.

## E-DISCOVERY AND LEGAL VENDORS

Sync your system to PACER to automate legal marketing.