



US005460136A

**United States Patent** [19]  
**Yamazaki et al.**

[11] **Patent Number:** **5,460,136**  
[45] **Date of Patent:** **Oct. 24, 1995**

[54] **EVAPORATIVE FUEL-ADSORBING DEVICE AND EVAPORATIVE EMISSION CONTROL SYSTEM INCLUDING SAME**

5,170,765 12/1992 Hoshino et al. .... 123/519

**FOREIGN PATENT DOCUMENTS**

1-159455 6/1989 Japan .

[75] Inventors: **Kazumi Yamazaki; Kouichi Hidano; Teruo Wakashiro; Takeshi Hara**, all of Wako; **Tomoyuki Kawakami**, Tochigi, all of Japan

*Primary Examiner*—Thomas N. Moulis  
*Attorney, Agent, or Firm*—Nikaido, Marmelstein, Murray & Oram

[73] Assignee: **Honda Giken Kogyo Kabushiki Kaisha**, Minato, Japan

[57] **ABSTRACT**

An evaporative fuel-adsorbing device adsorbs evaporative fuel generated from a fuel tank of an internal combustion engine. A partition divides the interior of a casing at least into a first adsorbent chamber and a second adsorbent chamber. Adsorbents are charged in the first adsorbent chamber and the second adsorbent chamber, respectively, for adsorbing the evaporative fuel. The evaporative fuel from the fuel tank is permitted to flow into the first adsorbent chamber via a charging port provided therein. The evaporative fuel desorbed from the adsorbents in the adsorbent chambers is permitted to flow out of the first adsorbent chamber via a purging port provided therein. The second adsorbent chamber is communicated with the atmosphere via an air-inlet port. The maximum flow rate of the evaporative fuel through a communication passage connecting between the first and second adsorbent chambers is changed in dependence on at least one of an amount of the evaporative fuel flowing into the evaporative fuel-adsorbing device and an amount of the evaporative fuel flowing out of same. An evaporative emission control system incorporating the evaporative fuel-adsorbing device is also provided.

[21] Appl. No.: **329,831**

[22] Filed: **Oct. 27, 1994**

[30] **Foreign Application Priority Data**

Oct. 28, 1993 [JP] Japan ..... 5-292782  
Dec. 27, 1993 [JP] Japan ..... 5-348572

[51] Int. Cl.<sup>6</sup> ..... **F02M 25/08**

[52] U.S. Cl. .... **123/519; 123/520**

[58] Field of Search ..... 123/516, 518,  
123/519, 520

[56] **References Cited**

**U.S. PATENT DOCUMENTS**

4,308,840	1/1982	Hiramatsu	123/519
4,894,072	1/1990	Turner et al.	123/519
4,919,103	4/1990	Ishiquro et al.	123/519
4,951,643	8/1990	Sato et al.	123/519
5,056,494	10/1991	Kayanuma	123/519
5,111,795	5/1992	Thompson	123/519
5,143,041	9/1992	Franzke	123/516

**18 Claims, 6 Drawing Sheets**

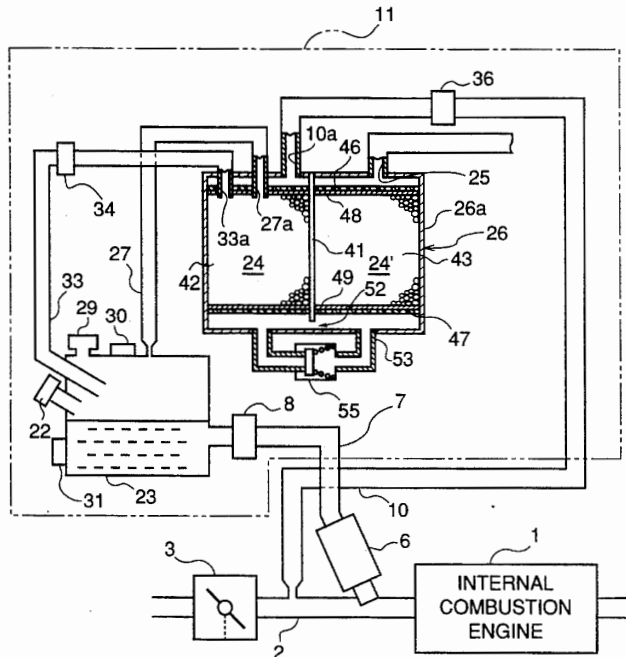
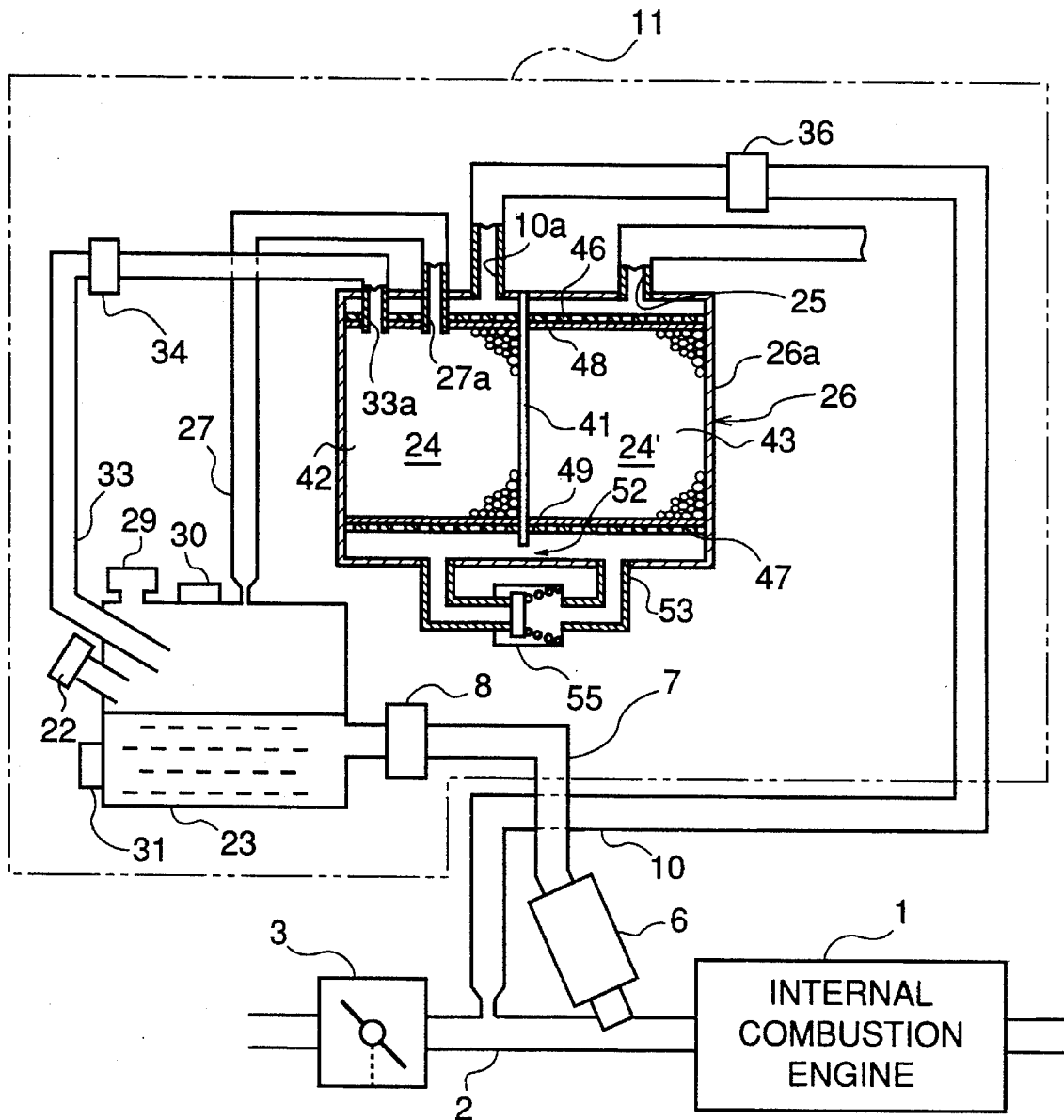

FIG. 1



**FIG. 2**

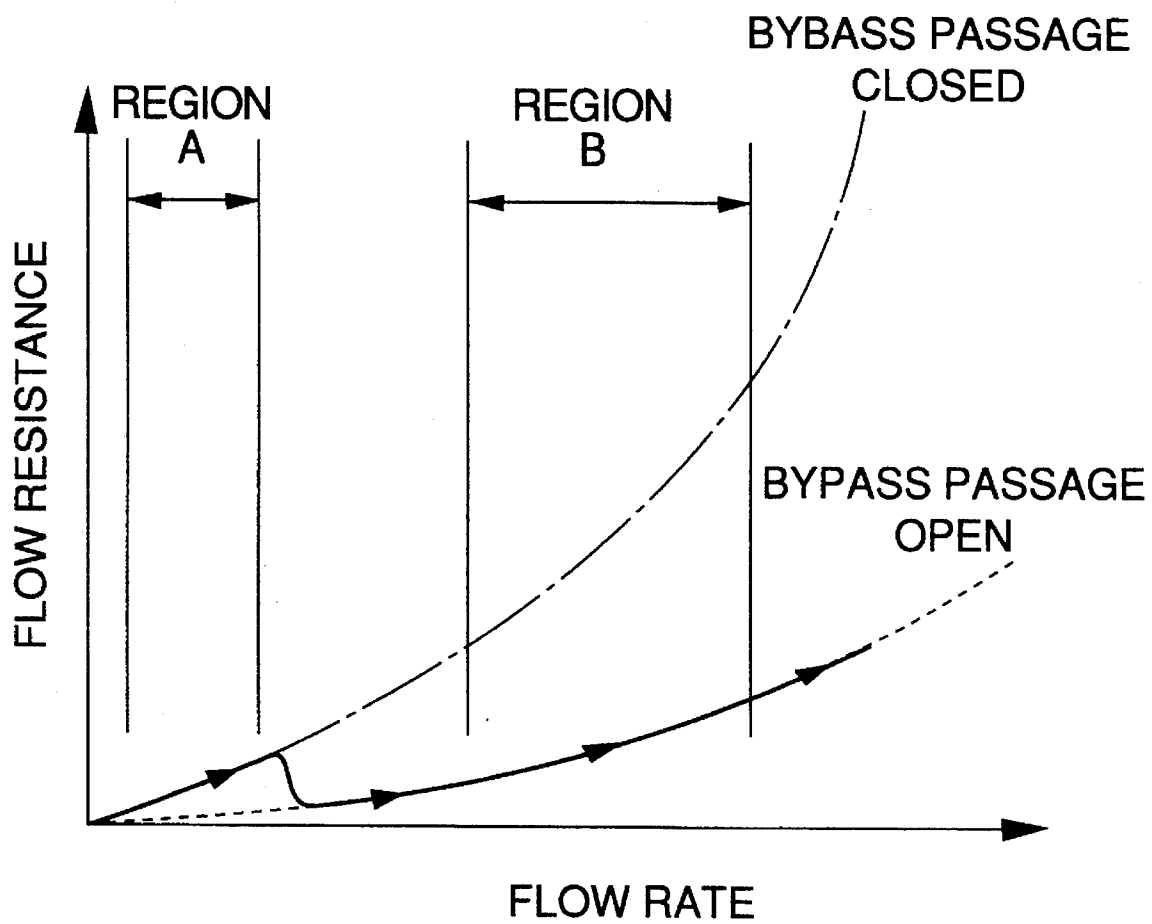
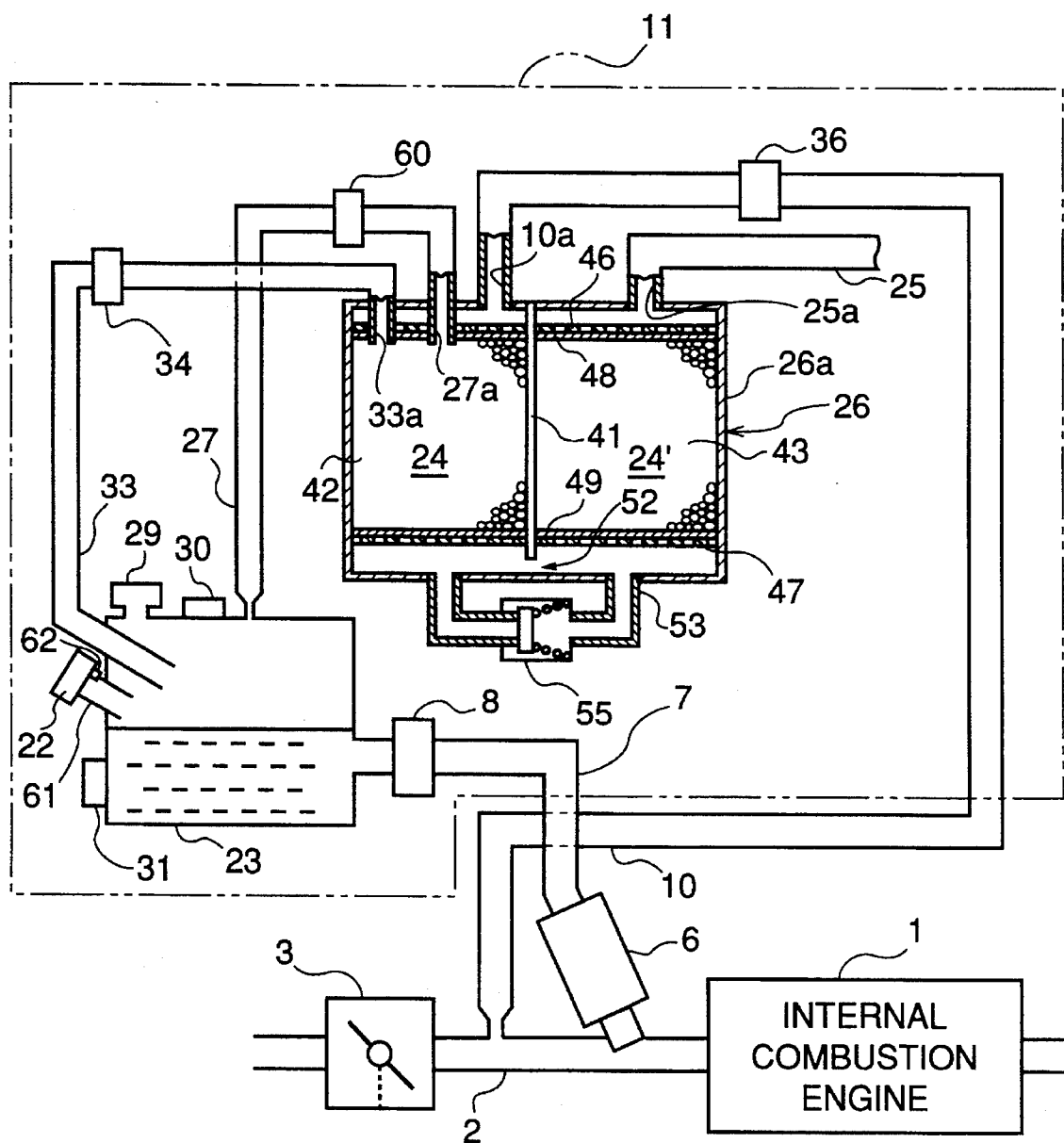
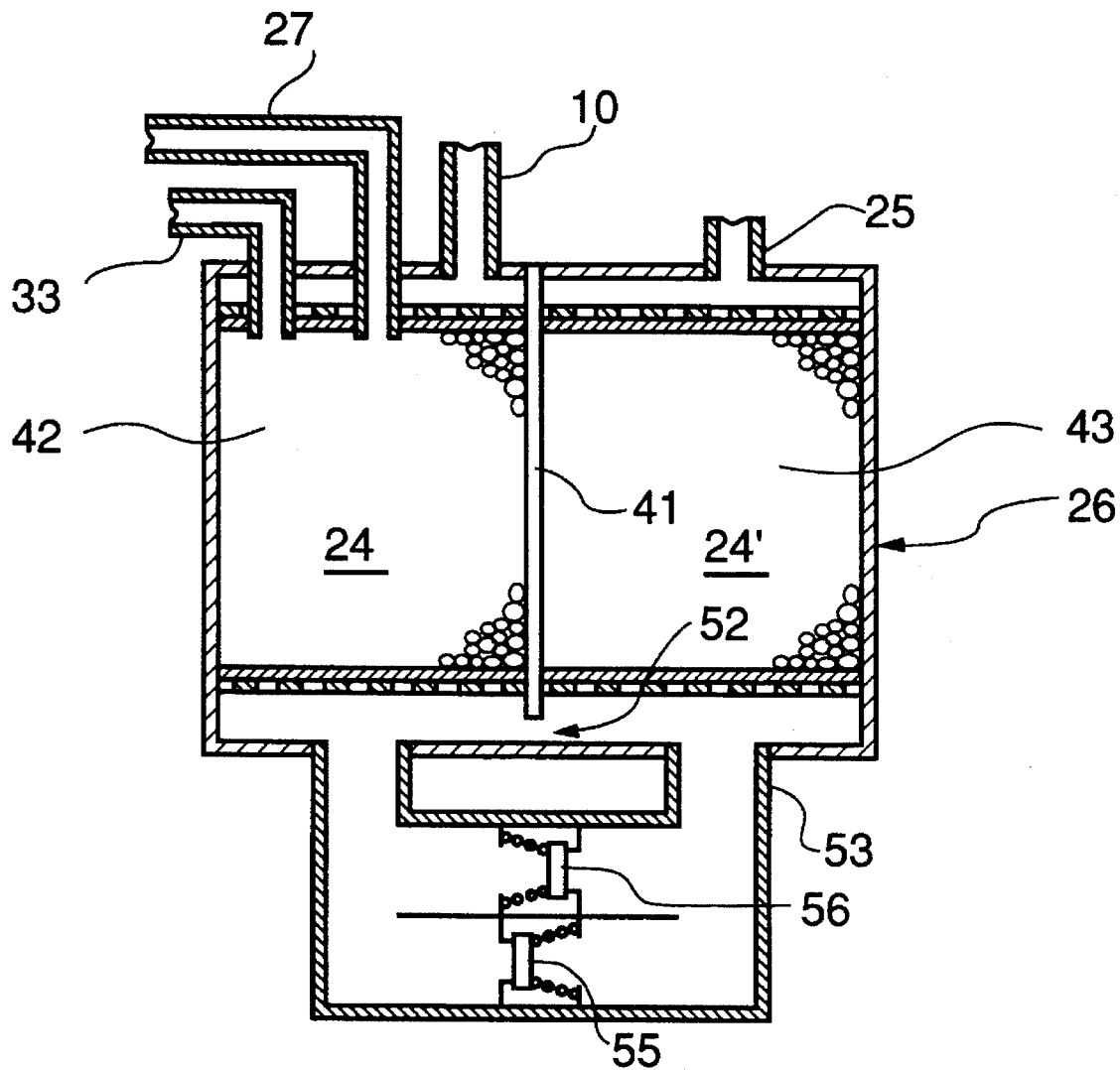

FIG.3



**FIG. 4**



# Explore Litigation Insights

Docket Alarm provides insights to develop a more informed litigation strategy and the peace of mind of knowing you're on top of things.

## Real-Time Litigation Alerts



Keep your litigation team up-to-date with **real-time alerts** and advanced team management tools built for the enterprise, all while greatly reducing PACER spend.

Our comprehensive service means we can handle Federal, State, and Administrative courts across the country.

## Advanced Docket Research



With over 230 million records, Docket Alarm's cloud-native docket research platform finds what other services can't. Coverage includes Federal, State, plus PTAB, TTAB, ITC and NLRB decisions, all in one place.

Identify arguments that have been successful in the past with full text, pinpoint searching. Link to case law cited within any court document via Fastcase.

## Analytics At Your Fingertips



Learn what happened the last time a particular judge, opposing counsel or company faced cases similar to yours.

Advanced out-of-the-box PTAB and TTAB analytics are always at your fingertips.

## API

Docket Alarm offers a powerful API (application programming interface) to developers that want to integrate case filings into their apps.

## LAW FIRMS

Build custom dashboards for your attorneys and clients with live data direct from the court.

Automate many repetitive legal tasks like conflict checks, document management, and marketing.

## FINANCIAL INSTITUTIONS

Litigation and bankruptcy checks for companies and debtors.

## E-DISCOVERY AND LEGAL VENDORS

Sync your system to PACER to automate legal marketing.