



[54] EVAPORATIVE EMISSION CONTROL SYSTEM FOR INTERNAL COMBUSTION ENGINES

5,209,210 5/1993 Ikeda et al. 123/516

FOREIGN PATENT DOCUMENTS

1-159455 6/1989 Japan .

[75] Inventors: Teruo Wakashiro; Takeshi Hara; Kouichi Hidano; Kazumi Yamazaki, all of Wako; Tomoyuki Kawakami, Tochigi, all of Japan

Primary Examiner—Thomas N. Moulis
Attorney, Agent, or Firm—Nikaido, Marmelstein, Murray & Oram

[73] Assignee: Honda Giken Kogyo Kabushiki Kaisha, Tokyo, Japan

[57] ABSTRACT

[21] Appl. No.: 335,373

[22] Filed: Nov. 3, 1994

[30] Foreign Application Priority Data

Nov. 4, 1993 [JP] Japan 5-298931

[51] Int. Cl.⁶ F02M 25/08

[52] U.S. Cl. 123/519

[58] Field of Search 123/516, 518, 123/519, 520

An evaporative emission control system for an internal combustion engine includes a canister for adsorbing evaporative fuel generated in the fuel tank, a first introducing passage for introducing evaporative fuel generated in the fuel tank into the canister on an occasion other than at refueling, a purging passage for purging evaporative fuel adsorbed in the canister into the intake passage of the engine, and a first air-inlet passage communicating between the canister and the atmosphere. First and second adsorbent chambers are formed in the canister and each accommodating an adsorbent. The first introducing passage and the purging passage are connected to the first adsorbent chamber. The first air-inlet passage is connected to the second adsorbent chamber. A communication passage communicates between the first adsorbent chamber and the second adsorbent chamber. A second introducing passage is connected to the first and second adsorbent chambers, for introducing evaporative fuel generated in the fuel tank into the canister at refueling. A second air-inlet passage communicates between the first adsorbent chamber and the atmosphere. An electromagnetic valve is arranged across the second introducing passage, for opening the same at refueling.

[56] References Cited

U.S. PATENT DOCUMENTS

4,308,840	1/1982	Hiramatsu et al.	123/519
4,790,283	12/1988	Uranishi et al.	123/519
4,817,576	4/1989	Abe et al.	123/519
4,894,072	1/1990	Turner et al.	123/519
4,915,643	8/1990	Sato et al.	123/519
4,919,103	4/1990	Ishiguro et al.	123/519
5,056,494	10/1991	Kayanuma	123/519
5,111,795	5/1992	Thompson	123/519
5,143,041	9/1992	Franzke	123/516

12 Claims, 9 Drawing Sheets

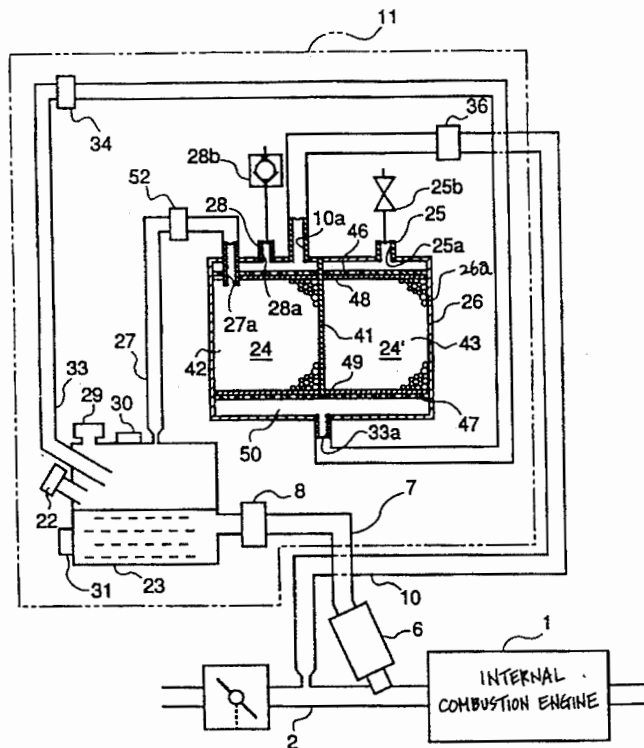

FIG. 1

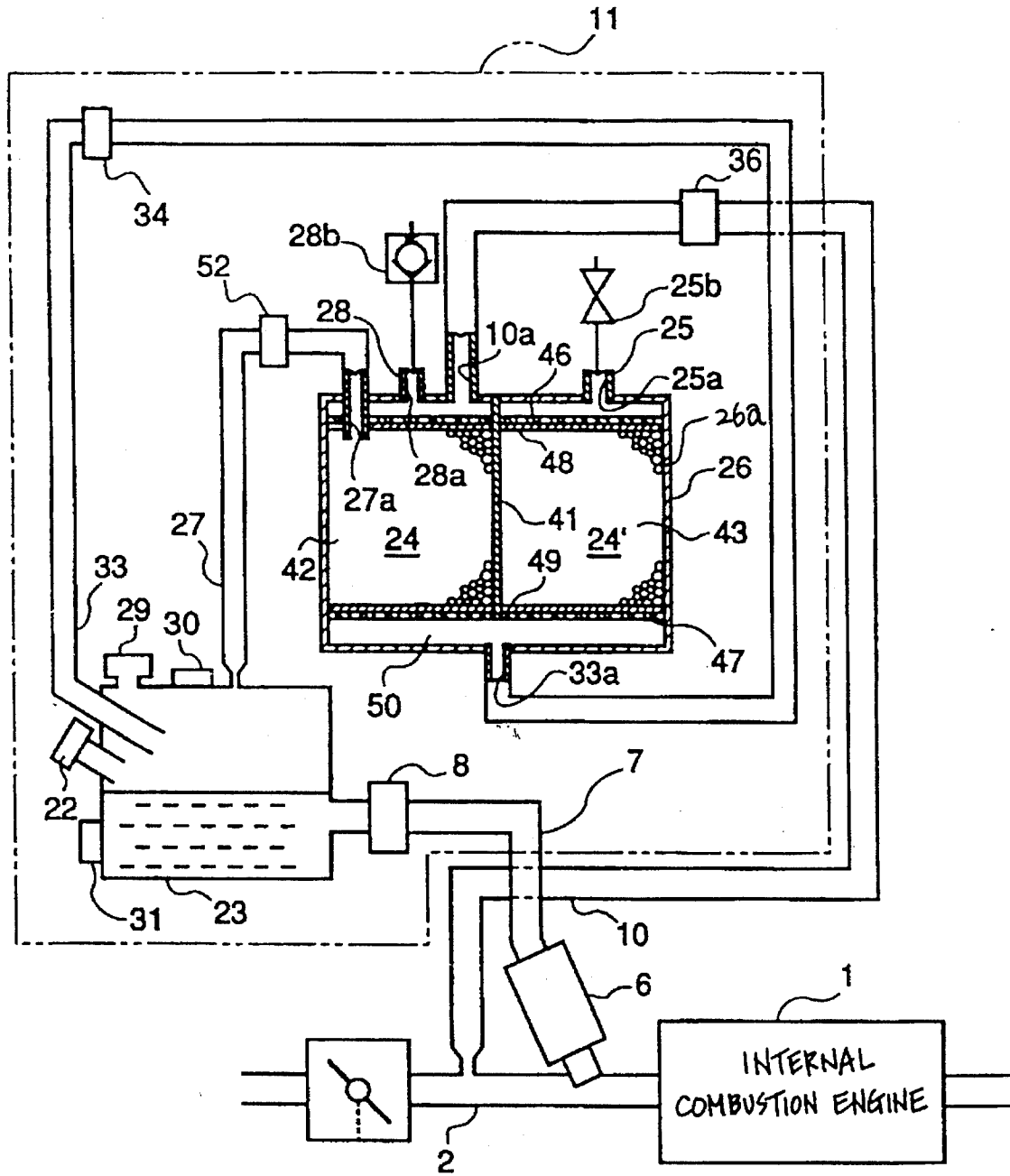

FIG. 2

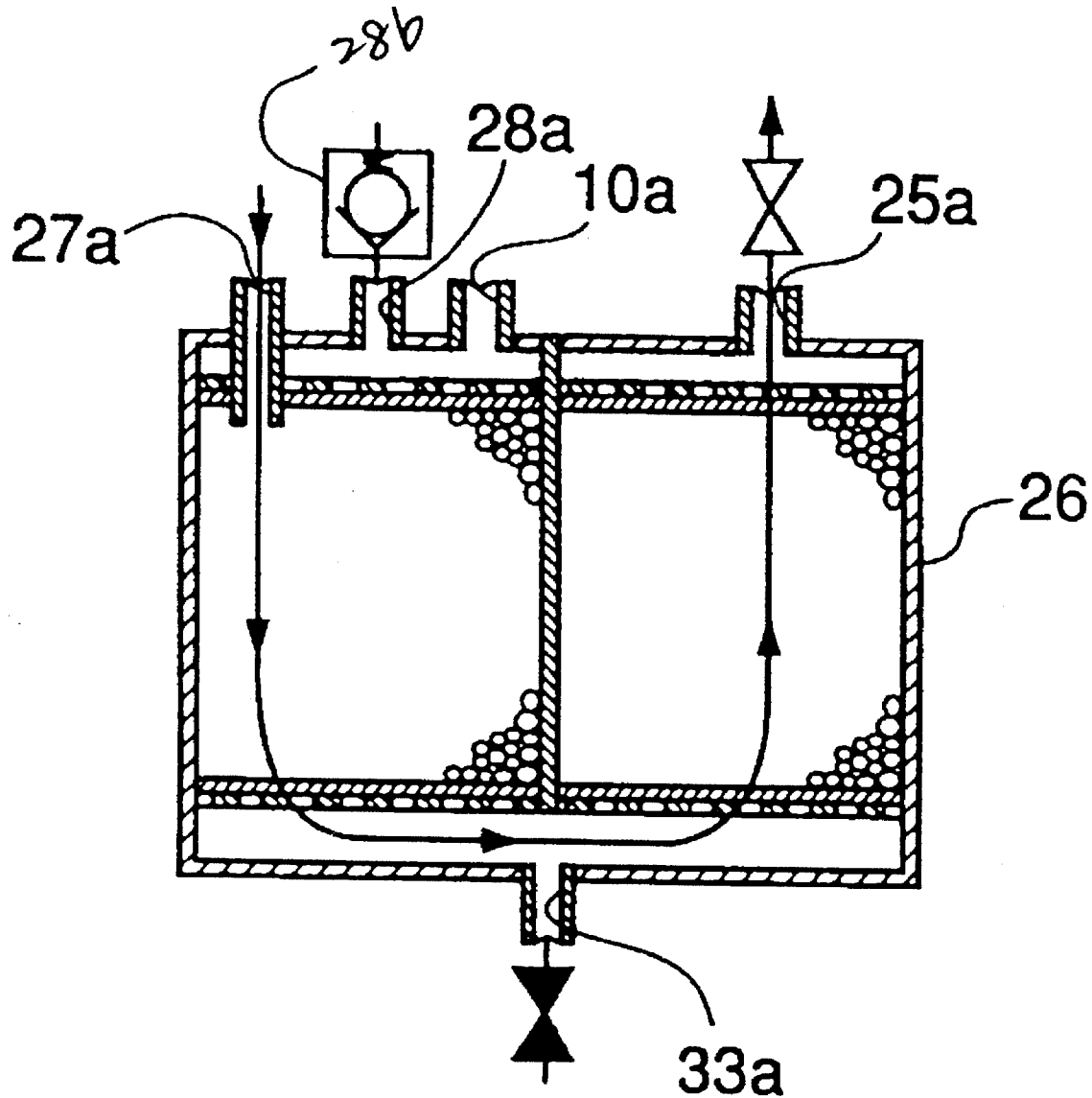

FIG. 3

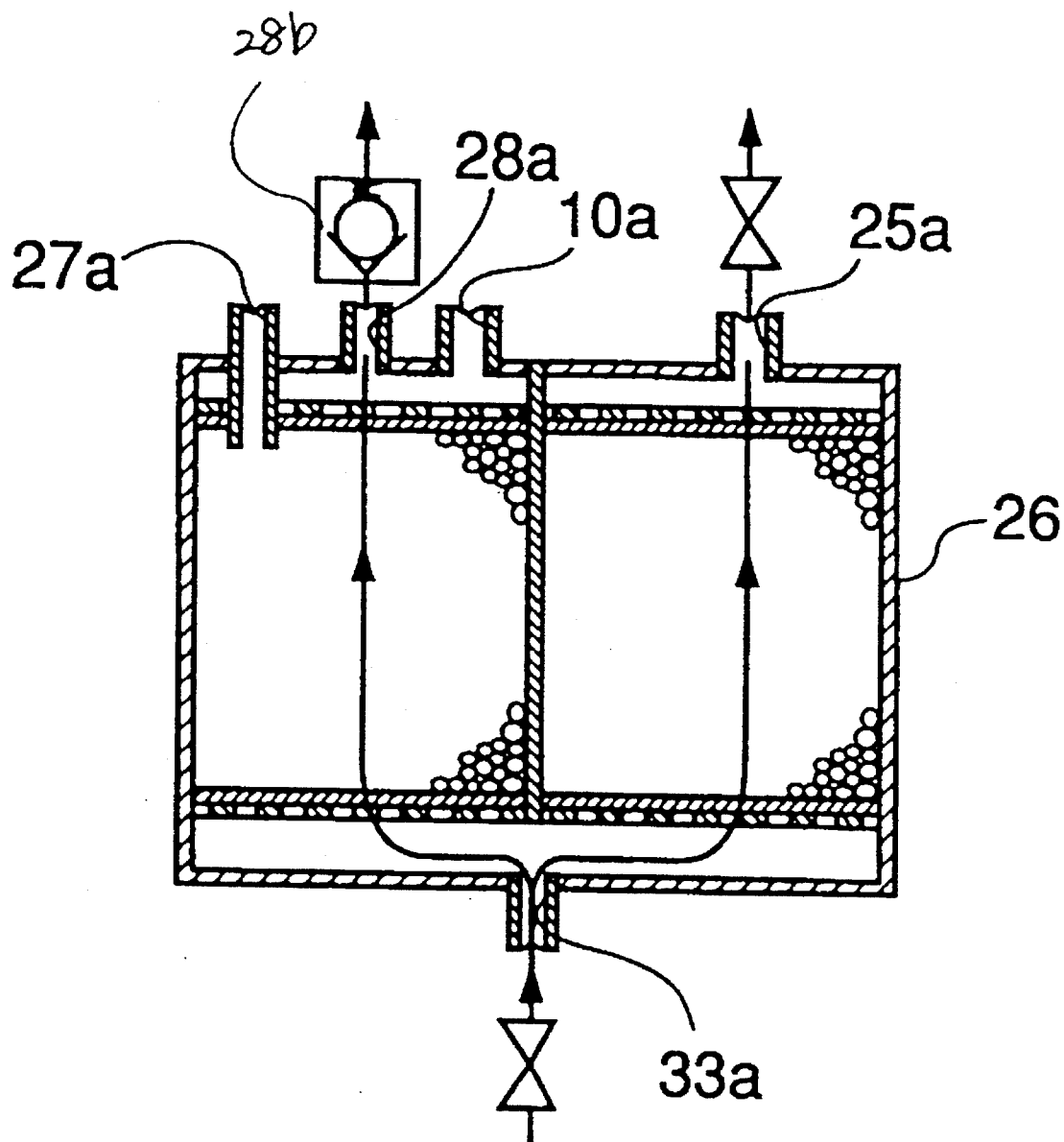
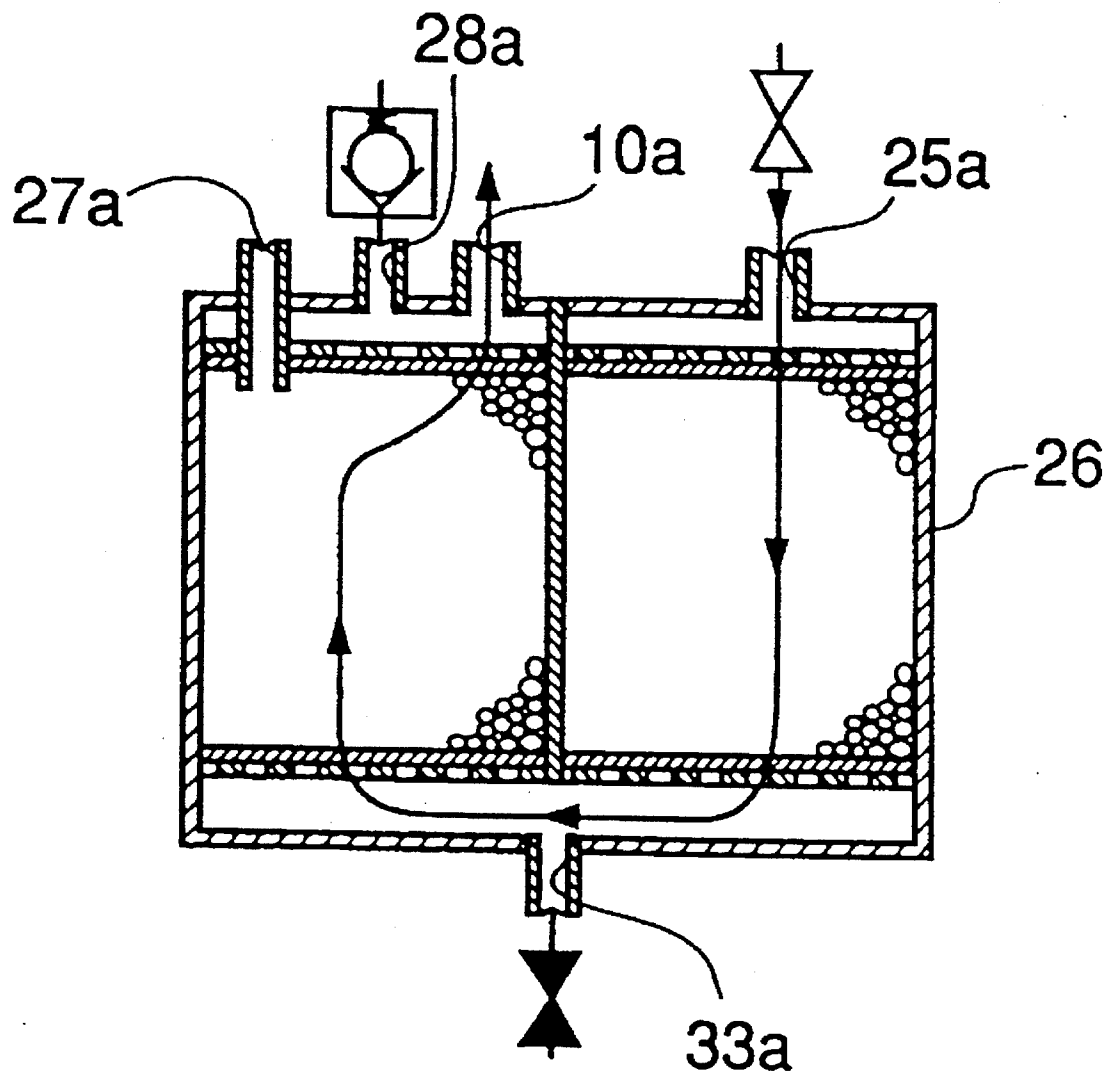

FIG. 4



Explore Litigation Insights

Docket Alarm provides insights to develop a more informed litigation strategy and the peace of mind of knowing you're on top of things.

Real-Time Litigation Alerts



Keep your litigation team up-to-date with **real-time alerts** and advanced team management tools built for the enterprise, all while greatly reducing PACER spend.

Our comprehensive service means we can handle Federal, State, and Administrative courts across the country.

Advanced Docket Research



With over 230 million records, Docket Alarm's cloud-native docket research platform finds what other services can't. Coverage includes Federal, State, plus PTAB, TTAB, ITC and NLRB decisions, all in one place.

Identify arguments that have been successful in the past with full text, pinpoint searching. Link to case law cited within any court document via Fastcase.

Analytics At Your Fingertips



Learn what happened the last time a particular judge, opposing counsel or company faced cases similar to yours.

Advanced out-of-the-box PTAB and TTAB analytics are always at your fingertips.

API

Docket Alarm offers a powerful API (application programming interface) to developers that want to integrate case filings into their apps.

LAW FIRMS

Build custom dashboards for your attorneys and clients with live data direct from the court.

Automate many repetitive legal tasks like conflict checks, document management, and marketing.

FINANCIAL INSTITUTIONS

Litigation and bankruptcy checks for companies and debtors.

E-DISCOVERY AND LEGAL VENDORS

Sync your system to PACER to automate legal marketing.