



- (51) **International Patent Classification:** Not classified
- (21) **International Application Number:** PCT/US2013/075767
- (22) **International Filing Date:** 17 December 2013 (17.12.2013)
- (25) **Filing Language:** English
- (26) **Publication Language:** English
- (30) **Priority Data:** 61/747,485 31 December 2012 (31.12.2012) US
- (71) **Applicant: OMNI MEDSCI, INC.** [US/US]; 1718 Newport Creek Drive, Ann Arbor, Michigan 48103 (US).
- (72) **Inventor: ISLAM, Mohammed N.;** 1718 Newport Creek Drive, Ann Arbor, Michigan 48103 (US).
- (74) **Agents: BIR, David S. et al;** Brooks Kushman P.C., 1000 Town Center, Twenty-Second Floor, Southfield, Michigan 48075 (US).
- (81) **Designated States** (unless otherwise indicated, for every kind of national protection available): AE, AG, AL, AM, AO, AT, AU, AZ, BA, BB, BG, BH, BN, BR, BW, BY, BZ, CA, CH, CL, CN, CO, CR, CU, CZ, DE, DK, DM, DO, DZ, EC, EE, EG, ES, FI, GB, GD, GE, GH, GM, GT, HN, HR, HU, ID, IL, IN, IR, IS, JP, KE, KG, KN, KP, KR,

KZ, LA, LC, LK, LR, LS, LT, LU, LY, MA, MD, ME, MG, MK, MN, MW, MX, MY, MZ, NA, NG, NI, NO, NZ, OM, PA, PE, PG, PH, PL, PT, QA, RO, RS, RU, RW, SA, SC, SD, SE, SG, SK, SL, SM, ST, SV, SY, TH, TJ, TM, TN, TR, TT, TZ, UA, UG, US, UZ, VC, VN, ZA, ZM, ZW.

(84) **Designated States** (unless otherwise indicated, for every kind of regional protection available): ARIPO (BW, GH, GM, KE, LR, LS, MW, MZ, NA, RW, SD, SL, SZ, TZ, UG, ZM, ZW), Eurasian (AM, AZ, BY, KG, KZ, RU, TJ, TM), European (AL, AT, BE, BG, CH, CY, CZ, DE, DK, EE, ES, FI, FR, GB, GR, HR, HU, IE, IS, IT, LT, LU, LV, MC, MK, MT, NL, NO, PL, PT, RO, RS, SE, SI, SK, SM, TR), OAPI (BF, BJ, CF, CG, CI, CM, GA, GN, GQ, GW, KM, ML, MR, NE, SN, TD, TG).

**Declarations under Rule 4.17:**

- as to applicant's entitlement to apply for and be granted a patent (Rule 4.17(H))
- as to the applicant's entitlement to claim the priority of the earlier application (Rule 4.17(Hi))

**Published:**

- without international search report and to be republished upon receipt of that report (Rule 48.2(g))

(54) **Title:** SHORT-WAVE INFRARED SUPER-CONTINUUM LASERS FOR NATURAL GAS LEAK DETECTION, EXPLORATION, AND OTHER ACTIVE REMOTE SENSING APPLICATIONS

FIGURE 16B

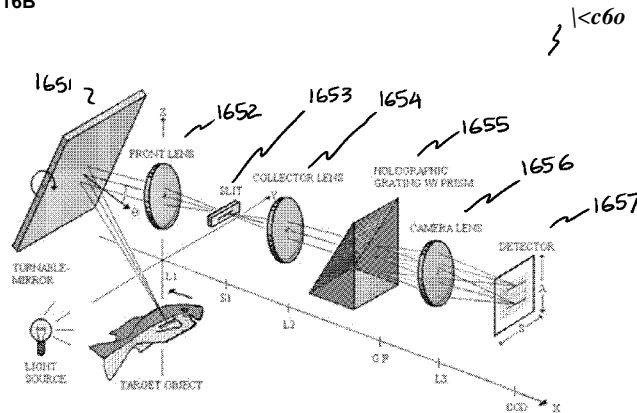

(57) **Abstract:** A system and method for using near-infrared or short-wave infrared (SWIR) light sources between approximately 1.4-1.8 microns, 2-2.5 microns, 1.4-2.4 microns, 1-1.8 microns for active remote sensing or hyper-spectral imaging for detection of natural gas leaks or exploration sense the presence of hydro-carbon gases such as methane and ethane. Most hydro-carbons (gases, liquids and solids) exhibit spectral features in the SWIR, which may also coincide with atmospheric transmission windows (e.g., approximately 1.4-1.8 microns or 2-2.5 microns). Active remote sensing or hyper-spectral imaging systems may include a fiber-based super-continuum laser and a detection system and may reside on an aircraft, vehicle, handheld, or stationary platform. Super-continuum sources may emit light in the near-infrared or SWIR s. An imaging spectrometer or a gas-filter correlation radiometer may be used to identify substances or materials such as oil spills, geology and mineralogy, vegetation, greenhouse gases, construction mater-

WO 2014/143276 A2

SHORT-WAVE INFRARED SUPER-CONTINUUM LASERS FOR NATURAL GAS LEAK  
DETECTION, EXPLORATION, AND OTHER ACTIVE REMOTE SENSING APPLICATIONS

CROSS-REFERENCE TO RELATED APPLICATIONS

[0001] This application claims the benefit of U.S. provisional application Serial No. 61/747,485 filed December 31, 2012, the disclosure of which is hereby incorporated by reference in its entirety.

[0002] This application is related to U.S. provisional application Serial No. 61,747,472 filed December 31, 2012; U.S. provisional application Serial Nos. 61/747,477 filed December 31, 2012; Serial No. 61/747,481 filed December 31, 2012; Serial No. 61/747,487 filed December 31, 2012; Serial No. 61/747,492 filed December 31, 2012; Serial No. 61/747,553 filed December 31, 2012; and Serial No. 61/754,698 filed January 21, 2013, the disclosures of which are hereby incorporated in their entirety by reference herein.

[0003] This application is being filed concurrently with International Application \_\_\_\_\_ entitled Near-Infrared Lasers For Non-Invasive Monitoring Of Glucose, Ketones, HBA1C, And Other Blood Constituents (OMNI0101PCT); International Application \_\_\_\_\_ entitled Short-Wave Infrared Super-Continuum Lasers For Early Detection Of Dental Caries (Attorney Docket No. OMNI0102PCT); U.S. Application \_\_\_\_\_ entitled Focused Near-Infrared Lasers For Non-Invasive Vasectomy And Other Thermal Coagulation Or Occlusion Procedures (Attorney Docket No. OMNI0103PUSP); U.S. Application \_\_\_\_\_ entitled Short-Wave Infrared Super-Continuum Lasers For Detecting Counterfeit Or Illicit Drugs And Pharmaceutical Process Control (Attorney Docket No. OMNI0105PUSP); U.S. Application \_\_\_\_\_ entitled Non-Invasive Treatment Of Varicose Veins (Attorney Docket No. OMNI0106PUSP); and U.S. Application \_\_\_\_\_ entitled Near-Infrared Super-Continuum Lasers For Early Detection Of Breast And Other Cancers (Attorney Docket No. OMNI0107PUSP), the disclosures of which are hereby incorporated in their entirety by reference herein.

## TECHNICAL FIELD

[0004] This disclosure relates to lasers and light sources for natural gas leak detection, natural gas exploration, and other active remote sensing or hyper-spectral imaging applications including systems and methods for using near-infrared or short-wave infrared light sources for remote detection of natural gas and other active remote sensing applications.

## BACKGROUND AND SUMMARY

[0005] Remote sensing or hyper-spectral imaging often uses the sun for illumination, and the short-wave infrared (SWIR) windows of about 1.5-1.8 microns and about 2-2.5 microns may be attractive because the atmosphere transmits in these wavelength ranges. Although the sun can be a bright and stable light source, its illumination may be affected by the time-of-day variations in the sun angle as well as weather conditions. For example, the sun may be advantageously used for applications such as hyper-spectral imaging only between about 9am to 3pm, and it may be difficult to use the sun during cloudy days or during inclement weather. In one embodiment, the hyper-spectral sensors measure the reflected solar signal at hundreds (e.g., 100 to 200+) contiguous and narrow wavelength bands (e.g., bandwidth between 5nm and 10nm). Hyper-spectral images may provide spectral information to identify and distinguish between spectrally similar materials, providing the ability to make proper distinctions among materials with only subtle signature differences. In the SWIR wavelength range, numerous gases, liquids and solids have unique chemical signatures, particularly materials comprising hydro-carbon bonds, O-H bonds, N-H bonds, etc. Therefore, spectroscopy in the SWIR may be attractive for stand-off or remote sensing of materials based on their chemical signature, which may complement other imaging information.

[0006] A SWIR super-continuum (SC) source may be able to replace at least in part the sun as an illumination source for active remote sensing, spectroscopy, or hyper-spectral imaging. In one embodiment, reflected light spectroscopy may be implemented using the SWIR light source, where the spectral reflectance can be the ratio of reflected energy to incident energy as a function of wavelength. Reflectance varies with wavelength for most materials because energy at certain wavelengths may be scattered or absorbed to different degrees. Using a SWIR light source may

permit 24/7 detection of solids, liquids, or gases based on their chemical signatures. As an example, natural gas leak detection and exploration may require the detection of methane and ethane, whose primary constituents include hydro-carbons. In the SWIR, for instance, methane and ethane exhibit various overtone and combination bands for vibrational and rotational resonances of hydro-carbons. In one embodiment, diffuse reflection spectroscopy or absorption spectroscopy may be used to detect the presence of natural gas. The detection system may include a gas filter correlation radiometer, in a particular embodiment. Also, one embodiment of the SWIR light source may be an all-fiber integrated SWIR SC source, which leverages the mature technologies from the telecommunications and fiber optics industry. Beyond natural gas, active remote sensing in the SWIR may also be used to identify other materials such as vegetation, greenhouse gases or environmental pollutants, soils and rocks, plastics, illicit drugs, counterfeit drugs, firearms and explosives, paints, and various building materials.

[0007] In one embodiment, a measurement system includes a light source configured to generate an output optical beam comprising one or more semiconductor sources configured to generate an input beam, one or more optical amplifiers configured to receive at least a portion of the input beam and to deliver an intermediate beam to an output end of the one or more optical amplifiers, and one or more optical fibers configured to receive at least a portion of the intermediate beam and to deliver at least the portion of the intermediate beam to a distal end of the one or more optical fibers to form a first optical beam. A nonlinear element is configured to receive at least a portion of the first optical beam and to broaden a spectrum associated with the at least a portion of the first optical beam to at least 10nm through a nonlinear effect in the nonlinear element to form the output optical beam with an output beam broadened spectrum, wherein at least a portion of the output beam broadened spectrum comprises a short-wave infrared wavelength between approximately 1400 nanometers and approximately 2500 nanometers, and wherein at least a portion of the one of more fibers is a fused silica fiber with a core diameter less than approximately 400 microns. A measurement apparatus is configured to receive a received portion of the output optical beam and to deliver a delivered portion of the output optical beam to a sample, wherein the delivered portion of the output optical beam is configured to generate a spectroscopy output beam from the sample. A receiver is configured to receive at least a portion of the spectroscopy output beam having a bandwidth of at least 10 nanometers and to process the portion of the spectroscopy output

beam to generate an output signal, and wherein the light source and the receiver are remote from the sample, and wherein the output signal is based on a chemical composition of the sample.

[0008] In another embodiment, a measurement system includes a light source configured to generate an output optical beam comprising a plurality of semiconductor sources configured to generate an input optical beam, a multiplexer configured to receive at least a portion of the input optical beam and to form an intermediate optical beam, and one or more fibers configured to receive at least a portion of the intermediate optical beam and to form the output optical beam, wherein the output optical beam comprises one or more optical wavelengths. A measurement apparatus is configured to receive a received portion of the output optical beam and to deliver a delivered portion of the output optical beam to a sample, wherein the delivered portion of the output optical beam is configured to generate a spectroscopy output beam from the sample. A receiver is configured to receive at least a portion of the spectroscopy output beam and to process the portion of the spectroscopy output beam to generate an output signal, wherein the light source and the receiver are remote from the sample, and wherein the output signal is based on a chemical composition of the sample.

[0009] In yet another embodiment, a method of measuring includes generating an output optical beam comprising generating an input optical beam from a plurality of semiconductor sources, multiplexing at least a portion of the input optical beam and forming an intermediate optical beam, and guiding at least a portion of the intermediate optical beam and forming the output optical beam, wherein the output optical beam comprises one or more optical wavelengths. The method may also include receiving a received portion of the output optical beam and delivering a delivered portion of the output optical beam to a sample located remotely from the generated output optical beam, and generating a spectroscopy output beam having a bandwidth of at least 10 nanometers from the sample, wherein the spectroscopy output beam comprises spectral features of hydrocarbons or organic compounds. The method may further include receiving at least a portion of the spectroscopy output beam and processing the portion of the spectroscopy output beam and generating an output signal, wherein the output signal is based on a chemical composition of the sample.

# Explore Litigation Insights

Docket Alarm provides insights to develop a more informed litigation strategy and the peace of mind of knowing you're on top of things.

## Real-Time Litigation Alerts



Keep your litigation team up-to-date with **real-time alerts** and advanced team management tools built for the enterprise, all while greatly reducing PACER spend.

Our comprehensive service means we can handle Federal, State, and Administrative courts across the country.

## Advanced Docket Research



With over 230 million records, Docket Alarm's cloud-native docket research platform finds what other services can't. Coverage includes Federal, State, plus PTAB, TTAB, ITC and NLRB decisions, all in one place.

Identify arguments that have been successful in the past with full text, pinpoint searching. Link to case law cited within any court document via Fastcase.

## Analytics At Your Fingertips



Learn what happened the last time a particular judge, opposing counsel or company faced cases similar to yours.

Advanced out-of-the-box PTAB and TTAB analytics are always at your fingertips.

## API

Docket Alarm offers a powerful API (application programming interface) to developers that want to integrate case filings into their apps.

## LAW FIRMS

Build custom dashboards for your attorneys and clients with live data direct from the court.

Automate many repetitive legal tasks like conflict checks, document management, and marketing.

## FINANCIAL INSTITUTIONS

Litigation and bankruptcy checks for companies and debtors.

## E-DISCOVERY AND LEGAL VENDORS

Sync your system to PACER to automate legal marketing.