

The Computer for the 21st Century

*Specialized elements of hardware and software,
connected by wires, radio waves and infrared, will be
so ubiquitous that no one will notice their presence*

by Mark Weiser

The most profound technologies are those that disappear. They weave themselves into the fabric of everyday life until they are indistinguishable from it.

Consider writing, perhaps the first information technology. The ability to represent spoken language symbolically for long-term storage freed information from the limits of individual memory. Today this technology is ubiquitous in industrialized countries. Not only do books, magazines and newspapers convey written information, but so do street signs, billboards, shop signs and even graffiti. Candy wrappers are covered in writing. The constant background presence of these products of "literacy technology" does not require active attention, but the information to be transmitted is ready for use at a glance. It is difficult to imagine modern life otherwise.

Silicon-based information technology, in contrast, is far from having become part of the environment. More than 50 million personal computers have been sold, and the computer nonetheless remains largely in a world of its own. It

is approachable only through complex jargon that has nothing to do with the tasks for which people use computers. The state of the art is perhaps analogous to the period when scribes had to know as much about making ink or baking clay as they did about writing.

The arcane aura that surrounds personal computers is not just a "user interface" problem. My colleagues and I at the Xerox Palo Alto Research Center think that the idea of a "personal" computer itself is misplaced and that the vision of laptop machines, dynabooks and "knowledge navigators" is only a transitional step toward achieving the real potential of information technology. Such machines cannot truly make computing an integral, invisible part of people's lives. We are therefore trying to conceive a new way of thinking about computers, one that takes into account the human world and allows the computers themselves to vanish into the background.

Such a disappearance is a fundamental consequence not of technology but of human psychology. Whenever people learn something sufficiently well, they cease to be aware of it. When you look at a street sign, for example, you absorb its information without consciously performing the act of reading. Computer scientist, economist and Nobelist Herbert A. Simon calls this phenomenon "compiling"; philosopher Michael Polanyi calls it the "tacit dimension"; psychologist J. J. Gibson calls it "visual invariants"; philosophers Hans Georg Gadamer and Martin Heidegger call it the "horizon" and the "ready-to-hand"; John Seely Brown of PARC calls it the "periphery." All say, in essence, that only when things disappear in this way are we freed to use them without thinking and so to focus beyond them on new goals.

The idea of integrating computers seamlessly into the world at large runs counter to a number of present-day trends. "Ubiquitous computing" in this context does not mean just computers that can be carried to the beach, jungle or airport. Even the most powerful notebook computer, with access to a worldwide information network, still focuses attention on a single box. By analogy with writing, carrying a superlaptop is like owning just one very important book. Customizing this book, even writing millions of other books, does not begin to capture the real power of literacy.

Furthermore, although ubiquitous computers may use sound and video in addition to text and graphics, that does not make them "multimedia computers." Today's multimedia machine makes the computer screen into a demanding focus of attention rather than allowing it to fade into the background.

Perhaps most diametrically opposed to our vision is the notion of virtual reality, which attempts to make a world inside the computer. Users don special goggles that project an artificial scene onto their eyes; they wear gloves or even bodysuits that sense their motions and gestures so that they can move about and manipulate virtual objects. Although it may have its purpose in allowing people to explore realms otherwise inaccessible—the insides of cells, the surfaces of distant planets, the information web of data bases—virtual reality is only a map, not a territory. It excludes desks, offices, other people not wearing goggles and bodysuits, weather, trees, walks, chance encounters and, in general, the infinite richness of the universe. Virtual reality focuses an enormous apparatus on simulating the world rather than on invisibly enhancing the world that already exists.

Indeed, the opposition between the

MARK WEISER is head of the Computer Science Laboratory at the Xerox Palo Alto Research Center. He is working on the next revolution of computing after workstations, variously known as ubiquitous computing or embodied virtuality. Before working at PARC, he was a professor of computer science at the University of Maryland; he received his Ph.D. from the University of Michigan in 1979. Weiser also helped found an electronic publishing company and a video arts company and claims to enjoy computer programming "for the fun of it." His most recent technical work involved the implementation of new theories of automatic computer memory reclamation, known in the field as garbage collection.

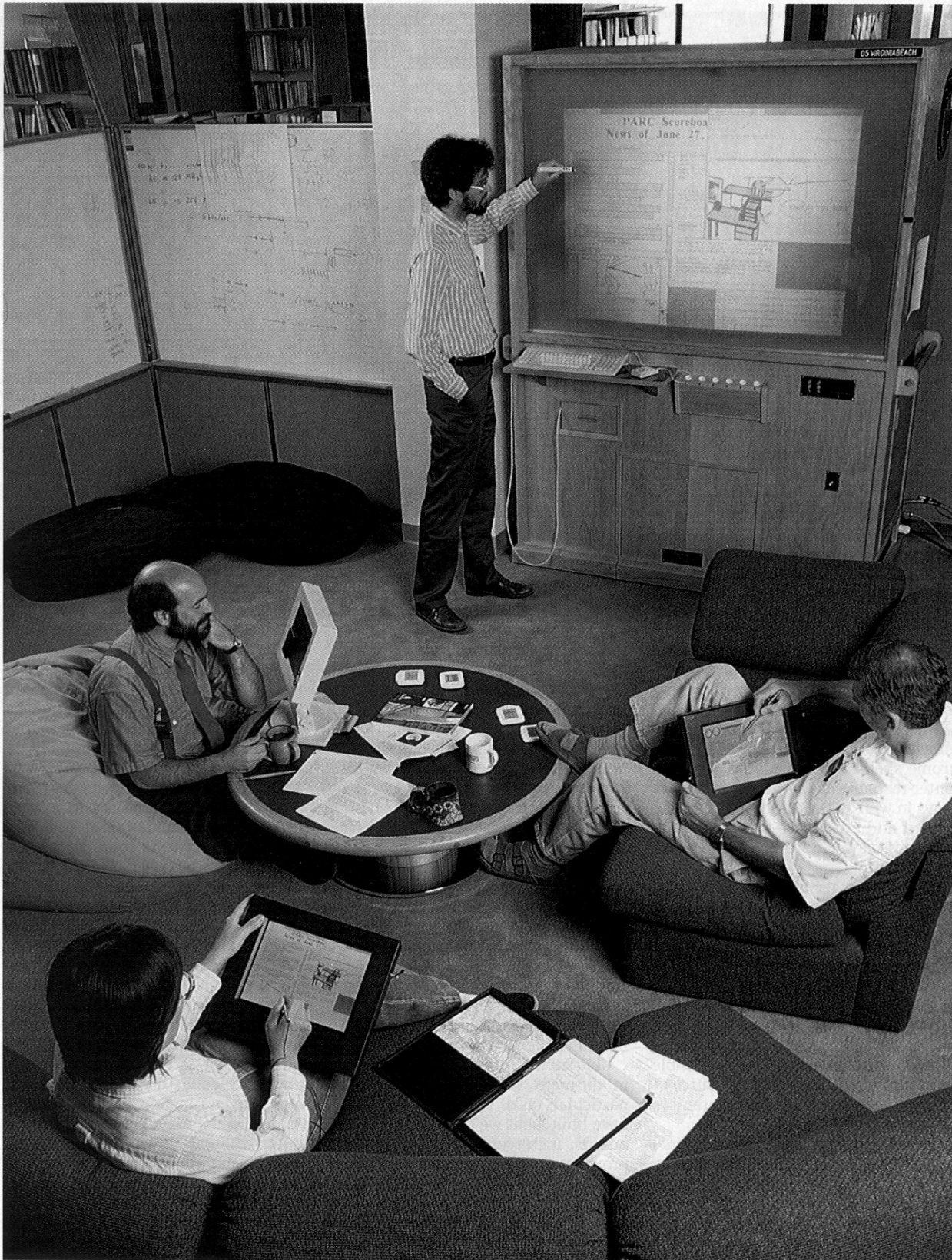

UBIQUITOUS COMPUTING begins to emerge in the form of live boards that replace chalkboards as well as in other devices at the Xerox Palo Alto Research Center. Computer scientists gather around a live board for discussion. Building boards

and integrating them with other tools has helped researchers understand better the eventual shape of ubiquitous computing. In conjunction with active badges, live boards can customize the information they display.

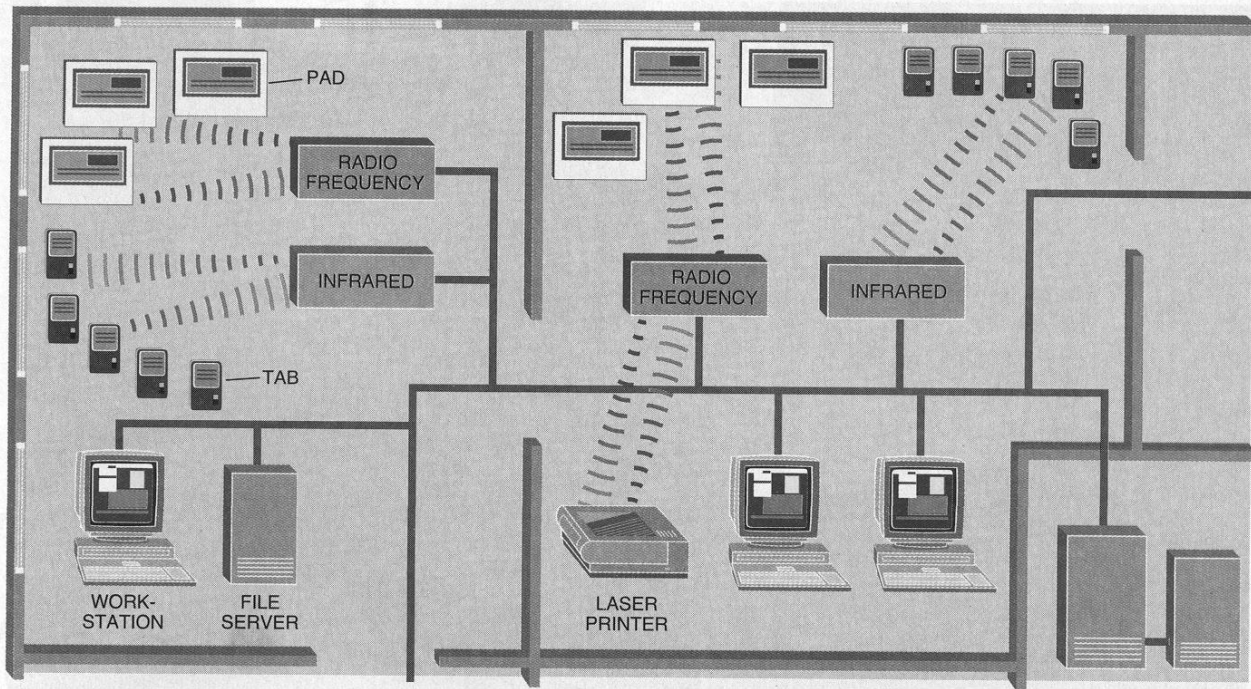

WIRED AND WIRELESS NETWORKS link computers and allow their users to share programs and data. The computers pictured here include conventional terminals and file servers, pocket-size machines known as tabs and page-size ones

known as pads. Future networks must be capable of supporting hundreds of devices in a single room and must also cope with devices—ranging from tabs to laser printers or large-screen displays—that move from one place to another.

notion of virtual reality and ubiquitous, invisible computing is so strong that some of us use the term “embodied virtuality” to refer to the process of drawing computers out of their electronic shells. The “virtuality” of computer-readable data—all the different ways in which they can be altered, processed and analyzed—is brought into the physical world.

How do technologies disappear into the background? The vanishing of electric motors may serve as an instructive example. At the turn of the century, a typical workshop or factory contained a single engine that drove dozens or hundreds of different machines through a system of shafts and pulleys. Cheap, small, efficient electric motors made it possible first to give each tool its own source of motive force, then to put many motors into a single machine.

A glance through the shop manual of a typical automobile, for example, reveals 22 motors and 25 solenoids. They start the engine, clean the windshield, lock and unlock the doors, and so on. By paying careful attention, the driver might be able to discern whenever he or she activated a motor, but there would be no point to it.

Most computers that participate in embodied virtuality will be invisible in

fact as well as in metaphor. Already computers in light switches, thermostats, stereos and ovens help to activate the world. These machines and more will be interconnected in a ubiquitous network. As computer scientists, however, my colleagues and I have focused on devices that transmit and display information more directly. We have found two issues of crucial importance: location and scale. Little is more basic to human perception than physical juxtaposition, and so ubiquitous computers must know where they are. (Today’s computers, in contrast, have no idea of their location and surroundings.) If a computer knows merely what room it is in, it can adapt its behavior in significant ways without requiring even a hint of artificial intelligence.

Ubiquitous computers will also come in different sizes, each suited to a particular task. My colleagues and I have built what we call tabs, pads and boards: inch-scale machines that approximate active Post-it notes, foot-scale ones that behave something like a sheet of paper (or a book or a magazine) and yard-scale displays that are the equivalent of a blackboard or bulletin board.

How many tabs, pads and board-size writing and display surfaces are there in a typical room? Look around you: at the inch scale, include wall notes, titles on book spines, labels on con-

trols, thermostats and clocks, as well as small pieces of paper. Depending on the room, you may see more than 100 tabs, 10 or 20 pads and one or two boards. This leads to our goal for initially deploying the hardware of embodied virtuality: hundreds of computers per room.

Hundreds of computers in a room could seem intimidating at first, just as hundreds of volts coursing through wires in the walls once did. But like the wires in the walls, these hundreds of computers will come to be invisible to common awareness. People will simply use them unconsciously to accomplish everyday tasks.

Tabs are the smallest components of embodied virtuality. Because they are interconnected, tabs will expand on the usefulness of existing inch-scale computers, such as the pocket calculator and the pocket organizer. Tabs will also take on functions that no computer performs today. For example, computer scientists at PARC and other research laboratories around the world have begun working with active badges—clip-on computers roughly the size of an employee I.D. card, first developed by the Olivetti Cambridge research laboratory. These badges can identify themselves to receivers placed throughout a building, thus making it possible to keep track of the people or objects to which they are attached.

In our experimental embodied virtuality, doors open only to the right badge wearer, rooms greet people by name, telephone calls can be automatically forwarded to wherever the recipient may be, receptionists actually know where people are, computer terminals retrieve the preferences of whoever is sitting at them, and appointment diaries write themselves. The automatic diary shows how such a simple task as knowing where people are can yield complex dividends: meetings, for example, consist of several people spending time in the same room, and the subject of a meeting is most probably the files called up on that room's display screen while the people are there. No revolution in artificial intelligence is needed, merely computers embedded in the everyday world.

My colleague Roy Want has designed a tab incorporating a small display that can serve simultaneously as an active badge, calendar and diary. It will also act as an extension to computer screens: instead of shrinking a program window down to a small icon on the screen, for example, a user will be able to shrink the window onto a tab display. This will leave the screen free for information and also let people arrange their computer-based projects in the area around their terminals, much as they now arrange paper-based projects in piles on desks and tables. Carrying a project to a different office for discussion is as simple as gathering up its tabs; the associated programs and files can be called up on any terminal.

The next step up in size is the pad, something of a cross between a sheet of paper and current laptop and palmtop computers. Robert Krivacic of PARC has built a prototype pad that uses two microprocessors, a workstation-size display, a multibutton stylus and a radio network with enough communications bandwidth to support hundreds of devices per person per room.

Pads differ from conventional portable computers in one crucial way. Whereas portable computers go everywhere with their owners, the pad that must be carried from place to place is a failure. Pads are intended to be "scrap computers" (analogous to scrap paper) that can be grabbed and used anywhere; they have no individualized identity or importance.

One way to think of pads is as an antidote to windows. Windows were invented at PARC and popularized by Apple in the Macintosh as a way of fitting several different activities onto the small space of a computer screen at the same

time. In 20 years computer screens have not grown much larger. Computer window systems are often said to be based on the desktop metaphor—but who would ever use a desk only nine inches high by 11 inches wide?

Pads, in contrast, use a real desk. Spread many electronic pads around on the desk, just as you spread out papers. Have many tasks in front of you, and use the pads as reminders. Go beyond the desk to drawers, shelves, coffee tables. Spread the many parts of the many tasks of the day out in front of you to fit both the task and the reach of your arms and eyes rather than to fit the limitations of glassblowing. Someday pads may even be as small and light as actual paper, but meanwhile they can fulfill many more of paper's functions than can computer screens.

Yard-size displays (boards) serve a

number of purposes: in the home, video screens and bulletin boards; in the office, bulletin boards, white boards or flip charts. A board might also serve as an electronic bookcase from which one might download texts to a pad or tab. For the time being, however, the ability to pull out a book and place it comfortably on one's lap remains one of the many attractions of paper. Similar objections apply to using a board as a desktop; people will have to become accustomed to having pads and tabs on a desk as an adjunct to computer screens before taking embodied virtuality any further.

Prototype boards, built by Richard Bruce and Scott Elrod of PARC, are in use at several Xerox research laboratories. They measure about 40 by 60 inches and display 1,024 x 768 black-and-white pixels. To manipulate the

The Active Badge

This harbinger of inch-scale computers contains a small microprocessor and an infrared transmitter. The badge broadcasts the identity of its wearer and so can trigger automatic doors, automatic telephone forwarding and computer displays customized to each person reading them. The active badge and other networked tiny computers are called tabs.

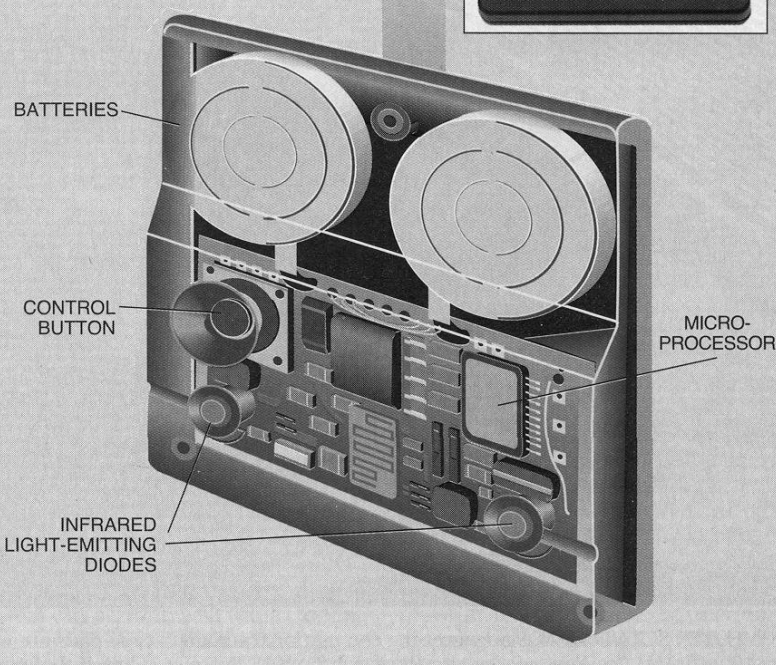

display, users pick up a piece of wireless electronic "chalk" that can work either in contact with the surface or from a distance. Some researchers, using themselves and their colleagues as guinea pigs, can hold electronically mediated meetings or engage in other forms of collaboration around a live board. Others use the boards as testbeds for improved display hardware, new "chalk" and interactive software.

For both obvious and subtle reasons, the software that animates a large shared display and its electronic chalk is not the same as that for a workstation. Switching back and forth between chalk and keyboard may involve walking several steps, and so the act is qualitatively different from using a keyboard and mouse. In addition, body size is an issue. Not everyone can reach the top of the board, so a Macintosh-style menu bar might have to run across the bottom of the screen instead.

We have built enough live boards to permit casual use: they have been placed in ordinary conference rooms and open areas, and no one need sign up or give advance notice before using them. By building and using these boards, researchers start to experience

and so understand a world in which computer interaction informally enhances every room. Live boards can usefully be shared across rooms as well as within them. In experiments instigated by Paul Dourish of EuroPARC and Sara Bly and Frank Halasz of PARC, groups at widely separated sites gathered around boards—each displaying the same image—and jointly composed pictures and drawings. They have even shared two boards across the Atlantic.

Live boards can also be used as bulletin boards. There is already too much text for people to read and comprehend all of it, and so Marvin Theimer and David Nichols of PARC have built a prototype system that attunes its public information to the people reading it. Their "scoreboard" requires little or no interaction from the user other than to look and to wear an active badge.

Prototype tabs, pads and boards are just the beginning of ubiquitous computing. The real power of the concept comes not from any one of these devices—it emerges from the interaction of all of them. The hundreds of processors and displays are not a "user interface" like a mouse and windows, just

a pleasant and effective "place" to get things done.

What will be most pleasant and effective is that tabs can animate objects previously inert. They can beep to help locate mislaid papers, books or other items. File drawers can open and show the desired folder—no searching. Tabs in library catalogues can make active maps to any book and guide searchers to it, even if it is off the shelf, left on a table by the last reader.

In presentations, the size of text on overhead slides, the volume of the amplified voice, even the amount of ambient light, can be determined not by guesswork but by the desires of the listeners in the room at that moment. Software tools for tallying votes instantly and consensus checking are already available in electronic meeting rooms of some large corporations; tabs can make them widespread.

The technology required for ubiquitous computing comes in three parts: cheap, low-power computers that include equally convenient displays, software for ubiquitous applications and a network that ties them all together. Current trends suggest that

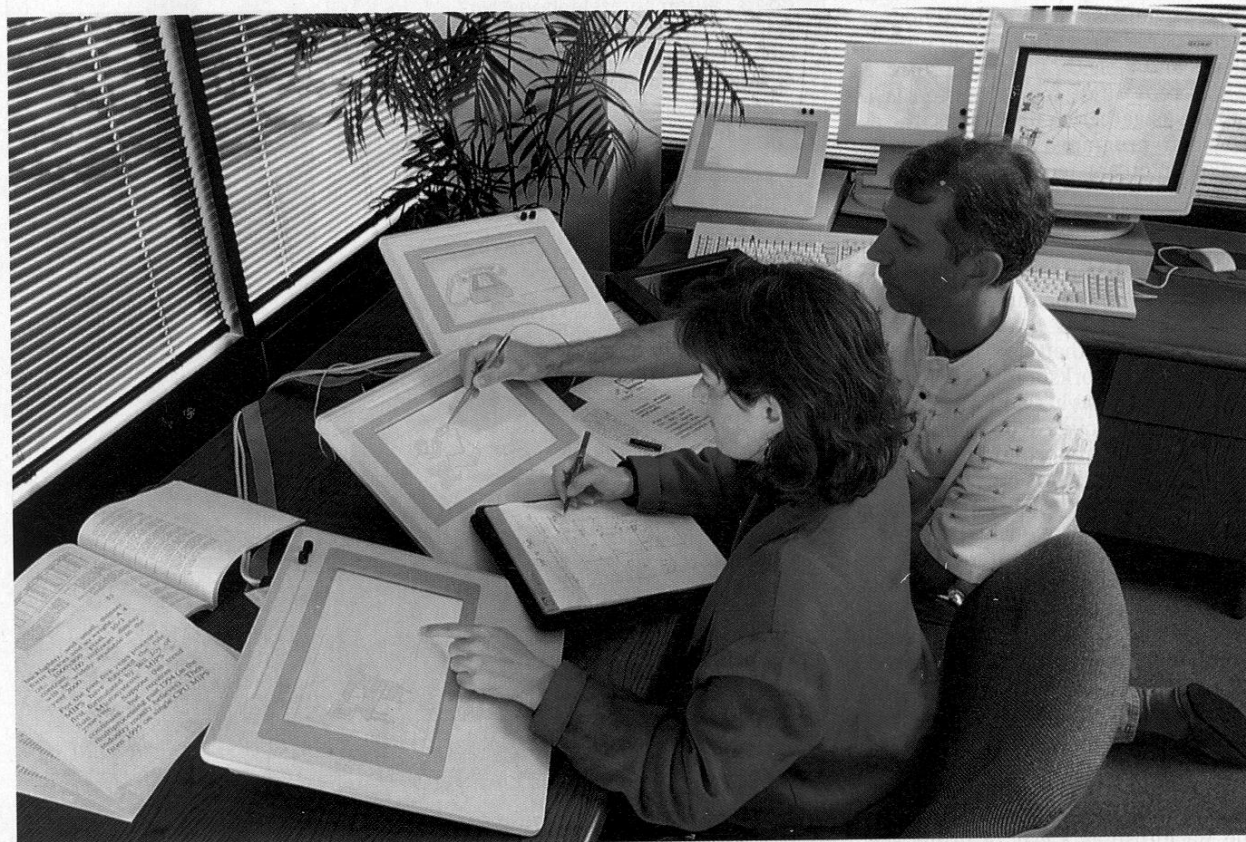

COMPUTER SCRATCHPADS augment the conventional screen in this office at the Xerox Palo Alto Research Center. Proto-

type pads are wired to conventional computers; thus far only a handful of wireless models have been built.

Explore Litigation Insights

Docket Alarm provides insights to develop a more informed litigation strategy and the peace of mind of knowing you're on top of things.

Real-Time Litigation Alerts



Keep your litigation team up-to-date with **real-time alerts** and advanced team management tools built for the enterprise, all while greatly reducing PACER spend.

Our comprehensive service means we can handle Federal, State, and Administrative courts across the country.

Advanced Docket Research



With over 230 million records, Docket Alarm's cloud-native docket research platform finds what other services can't. Coverage includes Federal, State, plus PTAB, TTAB, ITC and NLRB decisions, all in one place.

Identify arguments that have been successful in the past with full text, pinpoint searching. Link to case law cited within any court document via Fastcase.

Analytics At Your Fingertips



Learn what happened the last time a particular judge, opposing counsel or company faced cases similar to yours.

Advanced out-of-the-box PTAB and TTAB analytics are always at your fingertips.

API

Docket Alarm offers a powerful API (application programming interface) to developers that want to integrate case filings into their apps.

LAW FIRMS

Build custom dashboards for your attorneys and clients with live data direct from the court.

Automate many repetitive legal tasks like conflict checks, document management, and marketing.

FINANCIAL INSTITUTIONS

Litigation and bankruptcy checks for companies and debtors.

E-DISCOVERY AND LEGAL VENDORS

Sync your system to PACER to automate legal marketing.