

As the result of all these observations the Bavarian philosopher concluded that "electrical combinations, when not exhibiting their electric tension, were in a magnetic state; and that there existed a kind of electro-magnetic meridian depending on the electricity of the earth, and at right angles to the magnetic poles."\* These speculations are, as we see, sufficiently obscure, and, like those that we have hitherto described, failed to throw any light on the relation so anxiously sought after.

Nor can we give Oersted credit at this period for any more distinct apprehensions. In a work which

\* *Phil. Mag.*, vol. lviii. p. 43. It is curious to note that the English philosophers entirely neglected this study, being content to follow the brilliant lead of Sir Humphry Davy in another branch of the science. Indeed, it seems to have been the general opinion in this country, as late as the year 1818, that there was nothing more to be discovered. Bostock, in his *Account of the History and Present State of Galvanism*, published in London in that year, says:—

"Although it may be somewhat hazardous to form predictions respecting the progress of science, I may remark that the impulse, which was given in the first instance by Galvani's original experiments, was revived by Volta's discovery of the pile, and was carried to the highest pitch by Sir H. Davy's application of it to chemical decomposition, seems to have, in a great measure, subsided. It may be conjectured that we have carried the power of the instrument to the utmost extent of which it admits; and it does not appear that we are at present in the way of making any important additions to our knowledge of its effects, or of obtaining any new light upon the theory of its action" (p. 102).

Napoleon did not hold these views. In the First Consul's letter to the Minister, Chaptal, founding two prizes to encourage new researches in galvanism, he said:—"Galvanism, in my opinion, will lead to great discoveries."

he published in German, in 1807, on the identity of chemical and electrical forces, he observes : \*—

“When a plate composed of several thin layers is electrified, and the layers afterwards separated, each is found to possess an electric polarity, just as each fragment of a magnet possesses a magnetic polarity.

“There is, however, one fact which would appear to be opposed to the theory of the identity of magnetism and electricity. It is that electrified bodies act upon magnetic bodies, as if they [? the magnetic bodies] were endowed with no force in particular. It would be very interesting to science to explain away this difficulty ; but the present state of physics will not enable us to do so. It is, meanwhile, only a difficulty, and not a fact absolutely opposed to theory ; for we see in frictional electricity and in that of contact [galvanism] analogous phenomena. Thus, we can alter the tension of the electric pile by bringing near it an excited glass rod, and yet not affect in any way the chemical action. A long column of water, or a wetted thread of flax or wool, will also suffer a change in its electricity without experiencing any chemical changes.

“It would appear, then, that the forces can be superposed without interfering with each other when they operate under forms of different activities.

“The form of galvanic activity holds a middle place between those of magnetism and [static] electricity.

\* Chap. viii. pp. 235-6 of the French edition, *Recherches sur l'Identité des Forces Chimiques et Électriques*, Paris, 1813.

The force is in that form more latent than as electricity, and less so than as magnetism. It is, therefore, probable that the electric force, when superposed, will exercise a less influence on magnetism than on galvanism. In the galvanic pile, it is the electric state [tension] which it acquires that is affected by the approach of an excited glass rod; more, it is not that interior distribution of forces constituting magnetism that we can change by electricity, but it is the electric state which belongs to the magnet as to bodies in general.

“We do not pretend to decide anything in this matter; we only wish to clear up, as far as possible, a very obscure subject, and, in a question of such importance, we shall be very well satisfied if we have made it apparent that the principal objection to the identity of the forces which produce electricity and magnetism is rather a difficulty of reconciling facts than of the facts themselves.”

And again, on p. 238, he says:—“Steel when heated loses its magnetism, showing that it becomes a better conductor by the elevation of temperature, like electrical bodies. Magnetism, too, like electricity, exists in all bodies in nature, as Bruckmann and Coulomb have shown. From this it seems that the magnetic force is as general as the electric; and it remains to be seen whether electricity in its most latent state [*i. e.*, as galvanism] will not affect the magnetic needle *as such*.”

“This experiment will not be made without difficulty, for the electrical actions will blend and render the observations very complicated. In comparing the attractions on magnetic and non-magnetic bodies, some *data* will probably be obtained.”

In trying experiments with a view to the illustration of these hazy notions Oersted is said to have succeeded in obtaining indications of the action of the conducting wires of the pile, during the passage of electricity, on the needle ; but the phenomena were, at first view, not a little perplexing ; and it was not till after repeated investigation that, in the winter of 1819–20, the real nature of the action was satisfactorily made out.\*

Even then Oersted seems not to have clearly understood the full significance of his own experiment. Unlike Davy, who, when he first saw the fiery drops of potassium flow under the action of his battery, recorded his triumph in a few glowing words in his laboratory journal,† Oersted took no immediate steps,

\* “Professor Forchhammer, the pupil and friend of Oersted, states that, in 1818 and 1819, it was well known in Copenhagen that he was engaged in a special study of the connection of magnetism and electricity. Yet we must ascribe it to a happy impulse—the result, no doubt, of much anxious thought—that, at a private lecture to a few advanced students in the winter of 1819–20, he made the observation that a wire uniting the ends of a voltaic battery in a state of activity affected a magnet in its vicinity.”—*Ency. Brit.*, 8th ed., Dissertation vi. p. 973.

† On 16th October, 1807, while investigating the compound nature of the alkalis. On seeing the globules of potassium burst through the crust of the potash, and take fire as they entered the atmosphere, he could not contain his joy, but danced about the room in wild delight,

either to complete, or to publish, his discovery. "Although," he says, "the effect was unquestionable, it appeared to me, nevertheless, so confused that I deferred a minute examination of it to a period at which I hoped for more leisure." \* And when he had made this minute examination and published the results, he could not explain the phenomena by a better hypothesis than that negative electricity acts only on the northern pole, and positive only on the southern pole of the needle.†

This most important discovery may be thus briefly defined :—Supposing the electric current to pass from north to south through a wire, placed horizontally in the magnetic meridian, then a compass needle suspended above it will have its north end turned towards the west ; if below the wire, to the east ; if on the east side of it, the north end will be raised ; and if on the west side, depressed. These results Oersted first published in a Latin tract, dated the 21st July, 1820, a copy of which (with translation in English), will be found in the *Journal of the Society of Telegraph Engineers*, vol. v. pp. 459–69.

---

and some time elapsed before he could sufficiently compose himself to continue his experiments.—Bakewell's *Manual of Electricity*, London, 1857, p. 34.

\* Tyndall's *Lectures on Voltaic Electricity at the Royal Institution*, 1876.

† See concluding paragraph of his paper in the *Journal of the Soc. of Tel. Engs.*, vol. v. p. 468.

## CHAPTER X.

### ELECTRO-MAGNETISM AND MAGNETO-ELECTRICITY —HISTORY IN RELATION TO TELEGRAPHY (continued).

THE effect of Oersted's pamphlet was most wonderful. The enthusiasm, says Lardner,\* which had been lighted up by the great discovery of Volta twenty years before, and which time had moderated, was relumined, and the experimental resources of every cabinet and laboratory were brought to bear on the pursuit of the consequences of this new relation between sciences so long suspected of closer ties. The inquiry was taken up, more particularly, by Ampère and Arago, in France; by Davy, Faraday, Cumming, and Sturgeon, in England; and by Seebeck, Schweigger, De la Rive, Henry, and numerous other philosophers in all parts of Europe and America.

Among these, Ampère has assumed the first and highest place. No sooner was the fact discovered by Oersted made known, than that philosopher commenced the beautiful series of researches which has surrounded his name with so much lustre, and

\* *Electricity, Magnetism, and Meteorology*, vol. i. p. 205.

brought electro-dynamics within the pale of mathematical physics. On the 18th of September, 1820, within less than two months of the publication of Oersted's experiments, he communicated his first memoir on electro-magnetism to the Academy of Sciences.

In this paper was explained the law which determined the position of the magnetic needle in relation to the electric current. In order to illustrate this, he proposed that a man should imagine the current to be transmitted through his body, the positive pole being applied to his feet, and the negative pole to his head, so that the current shall pass upwards from the feet to the head. This being premised, a magnetic needle, freely supported on its centre of gravity, and placed before him, will throw itself at right angles to him ; the north pole pointing towards his left, and the south pole towards his right.

If the person through whose body the current thus passes turn round, so as to present his face in different directions, a magnetic needle, still placed before him, will have its direction determined by the same condition ; the north pole pointing always to the left, and the south to the right.

In the same memoir were described several instruments intended to be constructed ; especially spiral, or helical, wires, through which it was proposed to transmit the electric currents, and which, it was expected, would thereby acquire the properties of magnets, and

retain these properties so long as the current might be transmitted through them. The author also explained his theory of magnets, ascribing their attractive and directive powers to currents of electricity circulating constantly round their molecules, in planes at right angles to the line joining their poles; the position of the poles, on the one side or the other of these planes,\* depending on the direction of the revolving current.

While Ampère was proceeding with these researches, Arago directed his inquiries to the state of the wire through which the current was transmitted, so as to determine whether every part of its surface was endowed with the same magnetic properties. With this view, he placed iron filings around the wire, and found that they adhered to it so long as the current flowed, and fell away immediately the connection with the battery was broken. He also found that on placing small steel needles across the wire through which a current from a voltaic pile, or a discharge from a Leyden jar, was sent, they were attracted, and, on removal, were found to be permanently magnetised. Acting upon Ampère's theory of magnetism, he placed in a glass tube an ordinary sewing needle, and wound round the tube a copper wire. On sending a current through this wire the needle was magnetised, its polarity depending on the

\* *Annales de Chimie et de Physique*, Paris, 1820, vol. xv. pp. 59 and 170.



direction of the current. If the helix were right-handed, the north pole was found at the end at which the current entered; and if left-handed, the same end was a south pole. In the same way he was able to impart a temporary magnetism to soft iron wires.\*

Another important discovery, which followed fast on the heels of Oersted's experiments, was that of Schweigger, of Halle, announced on the 16th September, 1820. Observing that the deflection produced by the outward current of a battery flowing over the needle was the same as that of the return current under the needle, he made the wire proceed from and to his battery above and beneath the needle, and obtained, as he expected, twice the effect; by giving the wire another turn round the needle the effect was again doubled; a third turn produced six times the original deviation; a fourth, eight times, and so on. This effect may be thus formulated:—If a magnetised needle, free to move, be surrounded by a number of convolutions of insulated wire, the power of the current to deflect it will increase in proportion to the number of con-

\* *Annales de Chimie et de Physique*, vol. xv. p. 93. Soon after, and before any knowledge of Arago's experiments had reached England, Davy also succeeded in magnetising needles by the voltaic current, as well as by ordinary frictional electricity, and showed the effect of the conducting wire on iron filings. See his letter to Wollaston, dated November 12, 1820, in the *Phil. Trans.*, for 1821. About the same time Seebeck communicated a paper to the Berlin Academy on the same subject.

volutions.\* In this way the effect of a very feeble current may be so multiplied as to produce as great a deviation of the magnetic needle as would otherwise be produced by a very strong current.

On this principle are constructed instruments for indicating and measuring currents of electricity, called *electro-magnetic multipliers*, or, more commonly, *galvanometers* †—the former being the name originally given to the arrangement by Schweigger. His first contrivance was a very humble affair, consisting of a small compass-box, round which were coiled several turns of copper wire in a direction parallel to the meridian line of the card.‡ Yet this was the prototype of the beautiful instruments of Du Bois-Reymond and Sir William Thomson, in the former

\* The practical reader is, of course, aware that this definition is not strictly true,—for three reasons : 1st, as the convolutions increase, the strength of the current decreases, by reason of the increased resistance in the circuit ; 2nd, each convolution has less and less effect, as it is farther and farther removed from the needle ; and, 3rd, the current exerts less and less force on the needle, as it is deflected farther and farther from the plane of the current.

† In the early part of the century this name was applied to measuring instruments based on the chemical and calorific properties of the current ; but these are now denominated *voltameters*, and the name *galvanometer* is reserved exclusively for the class of apparatus described in the text.

‡ Schweigger's *Journal für Chemie und Physik*, vol. xxxi. pp. 1-17. A galvanometer of different form, called a *galvano-magnetic condenser*, with vertical coils and unmagnetised needle, was shortly after, but independently, devised by the celebrated Poggendorff, then a student at Berlin. As the *published* description of his apparatus preceded that of Schweigger's, he is sometimes regarded as the first inventor (*Gilbert's Annalen der Physik*, vol. lxxvii. pp. 422-29).

of which as many as 30,000 convolutions are sometimes employed.

There was, however, still wanting another discovery to bring the galvanometer to its present perfection, and this want was soon supplied. In deflecting a magnetic needle the current acts against the directive force of terrestrial magnetism; hence it is clear that if this force could be neutralised the deflection would be greater; in other words, a galvanometer, in which the needle is freed from the controlling action of the earth's magnetism, would be more sensitive than the same galvanometer when its needle was not so freed. Ampère suspended a single needle so that the earth's magnetism acted perpendicularly to it, and had, therefore, no directive force upon it; and he found that it set accurately at right angles to the current.

This led him to the invention of the double, or *astatic*, needles, which he thus describes in his memoir of 1821:—

“When a magnetic needle is withdrawn from the directive action of the earth, it sets itself, by the action of a voltaic conductor, in a direction which makes a right angle with the direction of the conductor, and has its south pole to the left of the current against which it is placed; so that if M. Oersted, in the experiments which he published in 1820, only obtained deviations of the needle which were less than a right angle, on placing it above or

below a conducting wire parallel to its direction, it was solely because the needle which he subjected to the action of the current was not withdrawn from that of the earth, and took consequently an intermediate position between the directions which the two forces tended to give it. There are several means of withdrawing a magnetic needle from the earth's action. A very simple one consists in attaching to a stout brass wire, which has its upper part curved and fitted with a steel point of suspension, two magnetic needles of equal strength, in such a manner that their poles are in opposite directions, so that the directive force of the earth upon one is destroyed by the action in the opposite direction which it exercises on the other. The needles are so arranged that the lower one is just below the conducting wires, and the upper one close above them. On sending a current through the convolutions the needles turn, until they take a direction at right angles with the conducting wire." \*

Having oscillated a magnetised needle, freely suspended in a circular copper cage, the bottom and sides

\* *Annales de Chimie et de Physique*, vol. xviii. p. 320. In Professor Cumming's paper *On the connection of Galvanism and Magnetism*, read before the Cambridge Philosophical Society on April 2, 1821, he described a near approach to the astatic needle. In order to neutralise the terrestrial magnetism he placed a small magnetised needle under the galvanometer needle.—*Trans. Cam. Phil. Soc.*, vol. i. p. 279. The credit of Ampère's discovery is usually attributed to Nobili. As in Noad's *Manual of Electricity*, London, 1859, p. 327; also Roget's *Electro-Magnetism*, in *Library of Useful Knowledge*, London, 1832, p. 42.

of which were very near the needle, Arago, in 1824, noticed that the oscillations rapidly diminished in extent, and very quickly ceased, as if the medium in which they were being produced had become more and more resistant. The proximity of the copper, while thus checking the *amplitude* of the oscillations, was observed to have no effect on their *duration*, they being accomplished in exactly the same time as in free air. By making the needle oscillate at different distances above discs of different materials, Arago found that distance considerably diminished the effect ; and that metals acted with more energy than wood, glass, &c.\*

Arago now conceived the idea of trying whether the disc which possessed this remarkable property would not draw the needle with it if itself rotated. The experiment was tried and resulted in the discovery of a new class of phenomena to which its author gave the name of *magnetism by rotation*. If we fix to a rotation apparatus, such as a table made for experiments on centrifugal force, a copper disc, about twelve inches diameter, and one-tenth inch thick, and just above it suspend, by a silk fibre, a magnetic needle, in such a manner that its point of suspension is exactly above the centre of the disc (care being taken to interpose a

\* *Annales de Chim. et de Physique*, vol. xxvii. p. 363. Seebeck, of Berlin, on repeating these experiments two years later, obtained analogous results. See *Pogg. Ann.*, vol. vii. We shall see further on, pp. 321, and 336-7, the use that has been made of this fact in the telegraphs of Gauss and Weber, and Steinheil.

screen of glass or paper, so that the agitation of the air resulting from the motion impressed upon the disc may have no effect upon the needle), and then put the disc in rotation, the needle is seen to deviate in the direction of this rotation, and to make with the magnetic meridian a greater or less angle according to the velocity with which the disc is revolved. If this movement be very rapid, the needle is deflected more and more, until finally it rotates with the disc.

The effect diminishes very rapidly with the distance of the needle from the disc ; and is still further lessened by cutting slits in the latter in the direction of rays—a fact which, as our practical readers know, is of the highest importance in the construction of electromagnets.

Whilst Arago was analysing the force that he had discovered, Babbage and Herschel, Barlow, Harris,\* and others, undertook an investigation of the causes that may vary its intensity. Messrs. Babbage and Herschel repeated Arago's experiment by inverting it. They found that discs of copper, or other substances, when freely suspended over a rotating horse-shoe magnet, turned in the same direction as the magnet, with a movement at first slow, but which gradually increased in rapidity. The interposition of plates of glass and of non-magnetic metallic bodies in no degree

\* For researches of the three first-named philosophers, see *Philosophical Transactions*, for 1825 ; for those of Sir W. Snow Harris, see same for 1831.

affected the results ; but it was not the same with plates of *iron*. The action was then greatly reduced, or even entirely annihilated.

These two philosophers confirmed the accuracy of Arago's observations on the influence of solutions of continuity, either partial or total, in the discs subjected to experiment. Thus, a light disc of copper, suspended at a given distance above a magnet, executed its (6) revolutions in 55". When cut in eight places, in the direction of radii near the centre, it required 121" to execute the same number ; but, on the parts cut out being again soldered in with tin, the original effect was almost attained, the disc performing its revolutions in 57". The same effects were obtained with other metals.

Sir W. Snow Harris, who made a great number of experiments on this subject, not only found great differences between bodies with regard to their power of drawing the needle after them when rotating, but also with regard to the property they possess of intercepting this action. He observed that iron, and magnetic substances generally, are not the only ones that are thus able to arrest the effect of magnetism by rotation. Plates of non-magnetic substances, such as copper, silver, zinc, will do the same, provided only they be sufficiently thick, as from three to five inches.

From a study of all these experiments Christie deduced the law that the force with which different substances draw along the magnetic needle in their

rotatory movement is proportional to their conducting power for electricity. But a full explanation of these phenomena could not be given until after Faraday's discoveries in 1831, when it was seen that they were, one and all, the result of the electric currents induced in the disc by its rotation in the field of the magnet. In the case of those discs in which slits, or rays, were cut, the free circulation of these currents was prevented, and, consequently, there was no effect on the needle.\*

In November 1825, a great advance was made on Arago's experiment of magnetising soft iron, by the invention of the electro-magnet—an instrument which, in one form or another, has become the basis of nearly every system of electric telegraphy. We owe this most important contrivance to Sturgeon, a well-known electrician of Woolwich, who had worked in his earlier days at the cobbler's last,† as Franklin had done at the printing stick, and Faraday at bookbinding. Fig. 10 shows the earliest form of the instrument—a piece of stout iron wire, bent into the form of a horse-shoe,

\* See Faraday's *Experimental Researches*, 1831; also Henry's classical paper on *Electro-dynamic Induction*, in *Trans. Amer. Phil. Society*, for 1839, vol. vi. p. 318.

† He was apprenticed to a shoemaker, and disliking the employment, at the age of nineteen entered the Westmoreland Militia, and two years later enlisted in the Royal Artillery. While in this corps he devoted his leisure to scientific studies, and made himself familiar with all the great facts of electricity and magnetism, which were then opening on the world. His subsequent career has created for him an undying name in the annals of electricity.



coated with an insulating varnish, and then bound round loosely with bare copper wire, the turns (of which there were sixteen) being, of course, separated from each other. This electro-magnet, when excited by a

FIG. 10.

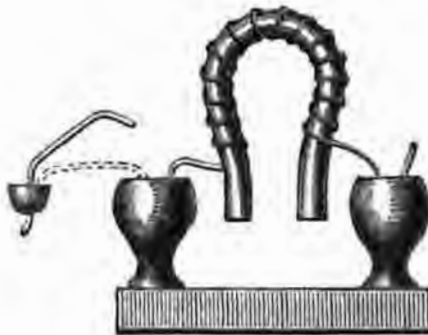

single voltaic pair of large (130 square inches) surface, was capable of supporting a weight of nine pounds, a wonderful performance in those days.\*

Some of the further steps in the perfection of the electro-magnet as used in telegraphy were made by Professor Henry in America, between the years 1828 and 1831, and it will be interesting to retrace them here, if only to see how little learned professors, fifty years ago, understood the conditions underlying the conversion of voltaic into magnetic force, and consequently how much groping in the dark, and stumbling to conclusions, where now Ohm's celebrated law makes everything so clear.

Henry was led to his first improvements in electro-magnets by a study of Schweigger's galvanometer,

\* *Transactions Society of Arts*, 1825, vol. xliii. pp. 38-52.

which resulted in the idea that a much nearer approximation to the requirements of Ampère's theory could be attained by insulating the conducting wire itself, instead of the rod to be magnetised, and by covering the whole surface of the iron with a series of coils in close contact.

In June 1828, he exhibited at the Albany Institute of New York, of which he was then professor, his electro-magnet, constructed on this principle. It consisted of a piece of soft iron, bent in the form of a horse-shoe, and closely wound with silk-covered copper wire, one-thirtieth of an inch in diameter. In this way he was able to employ a much larger number of convolutions, while each turn was more nearly at right angles with the magnetic axis of the bar. The lifting power of this magnet was, conformably to Henry's anticipations, much greater, *cæteris paribus*, than that of Sturgeon.

In March 1829, he exhibited, at the same place, a somewhat larger magnet of the same character. A round piece of iron, about one quarter inch diameter, was bent into the usual horse-shoe form, and tightly wound with thirty-five feet of silk-covered wire, in about four hundred turns, with silk ribbon between. A pair of small battery plates, which could be dipped into a tumbler of dilute acid, were soldered, one to each end of the wire, and the whole mounted on a stand. With this small battery the magnet could be much more powerfully excited than another of the

same sized core, wound according to the method of Sturgeon and excited by a battery of twenty-eight plates of copper and zinc, each plate eight inches square.\*

"In the arrangement," says Henry, "of Arago and Sturgeon, the several turns of wire were not precisely at right angles to the axis of the rod, as they should be to produce the effect required by the theory, but slightly oblique, and, therefore, each tended to develop a separate magnetism not coincident with the axis of the bar. But in winding the wire over itself, the obliquity of the several turns compensated each other, and the resultant action was at the required right angles. The arrangement, then, introduced by myself was superior to those of Arago and Sturgeon, first, in the greater multiplicity of turns of wire, and second, in the better application of these turns to the development of magnetism.†

"The maximum effect, however, with this arrangement and a single battery was not yet obtained. After a certain length of wire had been coiled upon the iron, the power diminished with a further increase of the number of turns. This was due to the increased resistance which the longer wire offered to the con-

\* *Smithsonian Report*, 1878, p. 282.

† "When this conception," said Henry, "came into my brain, I was so pleased with it that I could not help rising to my feet and giving it my hearty approbation." It was his first discovery. See Professor Mayer's Eulogy of Henry, before the American Association for the Advancement of Science, 1880.

duction of electricity. Two methods of improvement, therefore, suggested themselves. The first consisted, not in increasing the length of the coil, but in using a number of separate coils on the same piece of iron. By this arrangement the resistance to the conduction of the electricity was diminished, and a greater quantity made to circulate around the iron from the same battery. The second method of producing a similar result consisted in increasing the number of elements of the battery, or, in other words, the projectile force of the electricity, which enabled it to pass through an increased number of turns of wire, and thus to develop the maximum power of the iron.\*

Employing a horse-shoe, formed from a cylindrical bar of iron, half an inch in diameter, and about ten inches long, and wound with thirty feet of fine copper wire, he found that, with a current from only  $2\frac{1}{2}$  square inches of zinc, the magnet held 14 lbs.† Winding upon its arms a second wire of the same length (30 feet) whose ends were similarly joined to the same galvanic pair, the magnet lifted 28 lbs. On these results Henry remarks :—

“ These experiments conclusively proved that a great development of magnetism could be effected by a very small galvanic pair, and also that the power of the coil was materially increased by multiplying the

\* *Smithsonian Report*, for 1857, p. 102.

† It must not be forgotten that at the time when this experimental magnet was made, the strongest electro-magnet in Europe was that of Sturgeon mentioned on p. 285, and then considered a prodigy.

number of wires, without increasing the length of each. The multiplication of the wires increases the power in two ways: first, by conducting a greater quantity of galvanism, and secondly, by giving it a more proper direction; for, since the action of a galvanic current is directly at right angles to the axis of a magnetic needle, by using several shorter wires we can wind one on each inch of the length of the bar to be magnetised, so that the magnetism of each inch will be developed by a separate wire. In this way the action of each particular coil becomes directed very nearly at right angles to the axis of the bar, and consequently the effect is the greatest possible. This principle is of much greater importance when large bars are used. The advantage of a greater conducting power from using several wires might, in a less degree, be obtained by substituting for them one large wire of equal sectional area; but in this case the obliquity of the spiral would be much greater, and consequently the magnetic action less.\*

In the following year, 1830, Henry pressed forward his researches to still higher results, assisted by his friend, Dr. Philip Ten-Eyck. "A bar of soft iron, 2 inches square, and 20 inches long, was bent into the form of a horse-shoe  $9\frac{1}{2}$  inches high (the sharp edges of the bar were first a little rounded by the hammer); it weighed 21 lbs. A piece of iron from the same bar weighing 7 lbs., was filed perfectly flat on one surface

\* Silliman's *American Journal of Science*, Jan. 1831, vol. xix. p. 402.

for an armature, or lifter. The extremities of the legs of the horse-shoe were also truly ground to the surface of the armature. Around this horse-shoe 540 feet of copper bell-wire were wound in nine coils of 60 feet each; these coils were not continued around the whole length of the bar, but each strand of wire (according to the principle before mentioned) occupied about two inches, and was coiled several times backward and forward over itself. The several ends of the wires were left projecting, and all numbered, so that the first and the last end of each strand might be readily distinguished. In this manner we formed an experimental magnet on a large scale, with which several combinations of wire could be made by merely uniting the different projecting ends. Thus, if the second end of the first wire be soldered to the first end of the second wire, and so on through all the series, the whole will form a continued coil of one long wire. By a different arrangement the whole may be formed into a double coil of half the length, or into a triple coil of one-third the length, and so on. The horse-shoe was suspended in a strong rectangular frame of wood, 3 feet 9 inches high, and 20 inches wide." \*

The accompanying figure, which we copy from the *Scientific American*, December 11, 1880, is an exact representation of this instrument, which is at present preserved in the College of New Jersey.

Two of the wires, one from each leg, being soldered

\* Silliman's *Journal*, for 1831.

FIG. 11.\*

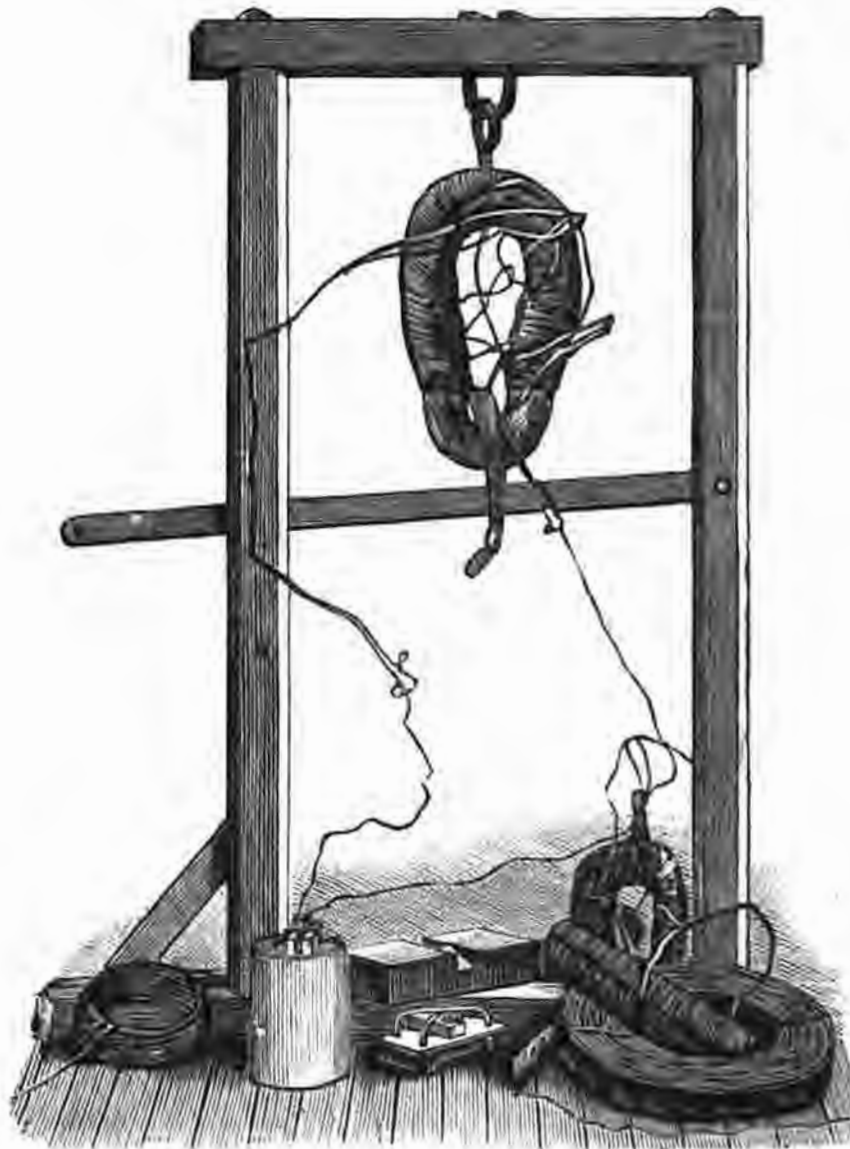

\* The coil at the right of the engraving represents the original silk-covered ribbon wire used by Henry in his celebrated experiments on induction. In the middle of the foreground is one of his pole-changers, which could also be used as a circuit breaker. He was accustomed to delight himself and his classes with this by making and breaking the current so quickly that a 28-lb. armature could not fall off, but was freed and attracted with a sharp snap.

together so as to form a single circuit of 120 feet, gave a lifting power of 60 lbs. The same two wires, when connected with the battery so as to form double circuits of 60 feet each, produced a lifting power of 200 lbs. ; and four wires used in the same way supported as much as 500 lbs. Six wires united in three pairs, so as to form three circuits of 180 feet each, gave a lifting power of only 290 lbs. ; while the same wires, when separately connected, as six parallel circuits, supported 570 lbs., or nearly double. When all the nine wires were joined up in parallel circuits with the battery, a lifting power of 650 lbs. was produced.\*

In all these experiments a small single pair was used, consisting of two concentric copper cylinders, with a zinc one between, the active surface of which (on both sides) amounted to only two-fifths of a square foot. The exciting liquid consisted of half a pint of dilute sulphuric acid.

A maximum portative force of 750 lbs. was obtained from a zinc-copper pair of 144 inches of active surface, all nine coils being joined in multiple arc.†

\* Henry was called to the chair of Natural Philosophy in the College of New Jersey, at Princeton, in 1832, and there he made two larger magnets for use in his investigations. One weighing 59½ lbs., and capable of sustaining 2063 lbs., is now in the cabinet of Yale College. The other, made in 1833, weighed 100 lbs., and could support 3500 lbs. It was many years before any magnet approaching this in power was constructed.

† Silliman's *Journal*, Jan. 1831. With a pair of plates, exposing exactly one square inch surface, the same arrangement of the coils could sustain a weight of 85 lbs. †



The only European physicist, who, up to this time, 1830, had obtained any results even approaching these, was Gerard Moll, professor of natural philosophy in the University of Utrecht, who having seen in London, in 1828, an electro-magnet of Sturgeon which could support 9 lbs., determined to try the effects of a larger galvanic apparatus. Having formed a horse-shoe,  $12\frac{1}{2}$  inches high, and  $2\frac{1}{4}$  inches diameter, he surrounded it with 26 feet of insulated copper wire, one-eighth of an inch thick, in a close coil of forty-four turns. The weight of the whole was about 26 lbs. With a current from a pair of 11 square feet of active (zinc) surface, this magnet sustained 154 lbs. This result was considered astonishing in Europe, yet Henry's horse-shoe, less in size and weight, supported nearly five times this load, with one-eleventh of Moll's battery power.\*

After finding that the maximum attractive power was obtained by his artifice of multiple coils, Henry proceeded to experiment with electro-magnets formed of one long coil ; and soon he was rewarded by a new discovery, namely, that, though multiple coils yielded the greatest attractive power close to the battery, one long continuous coil permitted a weaker attractive power to be exercised at a great distance, or through a great length of intervening wire.

Employing his earlier and smaller magnet of 1829,

\* Brewster's *Edinburgh Journal of Science*, October 1830, p. 214.

formed of a quarter-inch rod, and wound with 8 feet of insulated copper wire; he tried the effects of different battery powers, of different lengths of external wire, and of different lengths of coil. Excited with a single pair of zinc and copper, having 56 square inches of active surface, the magnet alone in the circuit sustained  $4\frac{1}{2}$  lbs. With 500 feet of copper wire, .045 inch diameter, interposed between battery and magnet, the weight supported was only two ounces, or thirty-six times less than in the first case. With 1000 feet of wire interposed, the lifting power of the magnet was only half an ounce.

Using now a trough battery of twenty-five pairs, the magnet in direct connection (which, with a single pair, had supported  $4\frac{1}{2}$  lbs.) lifted seven ounces, while with the thousand feet of interposed wire it sustained *eight* ounces.

“From this experiment,” says Henry,\* “it appears that the current from a galvanic *trough* is capable of producing greater magnetic effect on soft iron after traversing more than one-fifth of a mile of intervening wire than when it passes only through the wire surrounding the magnet. It is possible that the different states of the trough with respect to dryness may have exerted some influence on this remarkable result; but that the effect of a current from a trough, if not increased, is but slightly diminished in passing through

\* Silliman's *Journal*, January 1831, p. 403. Here is an instance of the stumbling to conclusions of which we spoke on p. 286.

a long wire is certain. \* \* \* From these experiments it is evident that, in forming the coil, we may either use one very long wire, or several short ones, as circumstances may require. In the first case, our galvanic combination must consist of a number of plates, so as to give 'projectile' force; in the second, it must be formed of a single pair."

Henry was thus the first to practically work out the different functions of two entirely different kinds of electro-magnet; the one, of numerous short coils, which he called the *quantity* magnet, and the other, of one very long coil, which he designated the *intensity* magnet. The former and more powerful, although little affected by a battery of many plates, was fully charged by a single pair; while the latter and feebler, which was but slightly affected by a single pair, was not only greatly excited by a battery of numerous elements, but was capable of receiving this excitation from a distant source.

In fact, Henry\* had experimentally established the important principles at which Ohm had, a short time before, arrived from purely theoretical considerations, and which are now so universally applied under the name of *Ohm's Laws*. A corollary of these, *viz.*, that, by combining an *intensity* battery, of many small pairs, with an *intensity* magnet, of a long fine wire, a very long intervening conductor can be employed without sensible diminution of the effect—

\* For more about Henry, see Appendix A.

is a fact which lies at the root of every system of electro-magnetic telegraphy.\*

In the course of these pages we have had abundant evidence of the fact that motion could produce electricity, and electricity motion. Dessaignes showed us how difference of temperature, or heat, could produce electricity; † and Peltier gave us the strict converse of this in the conversion of electricity into heat, including both its relations—hot and cold; again, we have seen how the nervous force in certain fishes could

\* In 1827, Georg Simon Ohm, professor of physics at Munich, published his celebrated formulæ; but for many years they failed to attract attention, and were no doubt unknown to Henry in 1830, as they were to Wheatstone in 1837. Numerous researches have, since Henry's time, been made with the view of determining in a rigorous manner the conditions necessary for obtaining the greatest electro-magnetic force. For these, see Ganot's *Physics*, London, 1881, p. 783; Noad's *Text Book of Electricity*, London, 1879, p. 285; Du Moncel's *Elements of Construction for Electro-Magnets*, London, 1883, *passim*; and the back volumes of *The Electrician*, for papers by Schwendler, Heaviside, &c.

† In 1815, or six years before Seebeck, who is always credited with the observation. (See Bostock's *History of Galvanism*, London, 1818, p. 101.) Many observations bearing on *thermo-electricity* had been made even long before Dessaignes. Passing by that of Theophrastus, 321 B.C., that tourmaline could be electrified by friction, as irrelevant, since he does not appear to have had any idea that the effect might be due to heat produced by the friction, we find that, in the year 1707, the thermo-electric properties of tourmaline were unmistakably pointed out by a German author, "J. G. S.," in his *Curious Speculations during Sleepless Nights*. In 1759, Æpinus called attention to the same phenomena, and pointed out that electricity of opposite kinds was developed at opposite ends of the crystal. In 1760, Canton observed the same properties in the topaz; and between 1789 and 1791, Haüy showed the thermo-electric properties of various other substances, as mesotype, prehnite, Iceland spar, and boracite.—Priestley's *History of Electricity*, 1767, pp. 314–26.

produce electricity, the converse of which was long and vainly sought after by Galvani and his disciples.

When, therefore, Oersted discovered the property of electricity to deflect a magnetic needle, and Arago its corollary—the magnetising power of the current, the conviction became strong that magnetism must be able in some way to produce electricity.

The credit of completely establishing this connection fell to the lot of our distinguished countryman, Michael Faraday. In his brilliant series of *Experimental Researches* commenced in 1831, he says:—  
“Certain effects of the induction of electrical currents have already been recognised and described; as those of magnetisation, Ampère’s experiments of bringing a copper disc near to a flat spiral, his repetition with electro-magnets of Arago’s extraordinary experiments, and perhaps a few others. Still, it appeared unlikely that these could be all the effects which induction by currents could produce. \* \* \*

“These considerations, with their consequence, the hope of obtaining electricity from ordinary magnetism, have stimulated me at various times to investigate experimentally the inductive effect of electric currents.”

Faraday thus describes his first successful experiment:—“203 feet of copper wire in one length were coiled round a large block of wood; other 203 feet of similar wire were interposed as a spiral between the turns of the first coil, and metallic contact everywhere prevented by twine. One of these helices was con-

ected with a galvanometer, and the other with a battery of 100 pairs. \* \* \* When the contact was made, there was a sudden and very slight effect at the galvanometer, and there was also a similar slight effect when the contact with the battery was broken. But whilst the current continued to flow through the one helix, no galvanometrical appearances, nor any effect like induction upon the other helix, could be perceived."

The same effects were produced in another way. Several feet of copper wire were stretched in wide zigzag forms, representing the letter W, on the surface of a broad board ; a second wire was stretched in precisely similar forms on a second board, so that when brought near the first, the wires should everywhere touch, except that a sheet of thick paper was interposed. One of these wires was connected with a galvanometer and the other with a voltaic battery. The first wire was then moved towards the second, and as it approached the needle was deflected. Being then removed, the needle was deflected in the opposite direction. As the wires approximated, the induced current was in the *contrary* direction to the inducing current ; and as they receded, the induced current was in the *same* direction as the inducing current.

Faraday next took a ring of soft iron, round the two halves of which he disposed two copper-wire coils. In passing a current through one coil, and thus magnetising the ring, a current was induced in the other coil, but, as in the former cases, only for an instant.

When the primary current ceased, and the magnet was unmade, an opposite current shot through the secondary coil. The primary coil was now suppressed, and the piece of soft iron embraced by the secondary coil was magnetised by a couple of powerful bar magnets, with which contact was alternately made and broken. Upon making contact the needle of the galvanometer was deflected; continuing the contact, the needle became indifferent and resumed its first position, and on breaking contact it was again deflected in the opposite direction, and then became once more indifferent. When the magnetic contacts were reversed the deflections of the needle were also reversed.

In order to prove that the induced current was not occasioned by any peculiar effect taking place during the formation of the magnet, Faraday made another experiment in which soft iron was rejected, and nothing but a permanent steel magnet employed. The ends of the empty helix being connected as before with the galvanometer, either pole of the magnet was thrust into the axis, and immediately the needle was momentarily deflected. On rapidly withdrawing the magnet, a second and instantaneous deflection ensued, and in the opposite direction.

The strength of these induced currents depended on many circumstances; as on the length and diameter of the wires of the coils, the energy of the inducing current, or the strength of the magnet, &c.

Hitherto, in order to produce the phenomenon of

induction by electric currents we have spoken of two conductors—one for the inducing, and another for the induced current; but experiment has shown that the same result can be obtained with only one conductor, and in this case the phenomenon is termed the induction of a current upon itself. In the sparking of relays and commutators of dynamo machines, &c., we have familiar examples of this action. Its discovery we owe to Professor Henry as far back as 1832, for he was the first to observe that, when the poles of a battery are united by means of a copper wire and mercury cups, a brilliant spark is obtained at the moment the circuit is broken by raising one end of the wire out of its cup of mercury. To obtain this effect it was found that the wire must not be less than twelve or fourteen yards long, and further, that if coiled into a helix the effect would be greatly increased.\*

Faraday made a particular study of this phenomenon, and showed the existence of the *extra current* not only on the breaking, but also on the making of the circuit. To the former he gave the name of *extra current direct*, to the latter *extra current inverse*. The latter, of course, cannot be directly perceived, since it flows in the same circuit as the current of the battery itself, and cannot be developed until this current is established, and, consequently, not until the circuit is closed. Its presence, however, is shown in an indirect way by the well-known phenomenon of retardation in magnetisations by means of the electric current.

\* Silliman's *Journal*, vol. xxii.



## CHAPTER XI.

TELEGRAPHS BASED ON ELECTRO-MAGNETISM AND  
MAGNETO-ELECTRICITY.

“The invention all admired ; and each how he  
To be the inventor missed ;—so easy seemed  
Once found, which yet unfound most would have thought  
Impossible.”—Milton's *Paradise Lost*, book vi.

1820.—*Ampère's Telegraph.*

VERY soon after Oersted's discovery of the deflecting power of the current, La Place, the distinguished French mathematician, suggested its employment for telegraphic purposes ; and, on the 2nd October in the same year (1820), Ampère, in a paper read before the Paris Academy of Sciences, sketched out roughly a telegraph in which the signals were to be indicated by the deflection of small magnets placed under the wires. His idea was a purely theoretical one, and was thrown out simply *par parenthèse* in the course of his memoir.

He says :—“ According to the success of the experiment to which La Place drew my attention, one could, by means of as many pairs of conducting wires and magnetic needles as there are letters, and by placing each letter on a separate needle, establish, by the aid of a pile placed at a distance, and which could be

made to communicate by its two extremities with those of each pair of conductors, a sort of telegraph, which would be capable of indicating all the details that one would wish to transmit through any number of obstacles to a distant observer. By connecting with the pile a key-board whose keys would carry the same letters and establish the connection (with the various wires) by their depression, this means of correspondence could be established with great facility, and would only occupy the time necessary for touching at one end, and reading at the other, each letter." \*

It will be seen from this passage, which we have literally translated from the original, that Ampère makes no mention of surrounding the needles with *coils of wire*, as is so frequently stated by writers on the telegraph. Indeed he could not then have even heard of the galvanometer ; for, although Schweigger's paper on the subject was read at Halle on the 16th September, 1820, it was not published until the November following.

#### 1830.—*Ritchie's Telegraph.*

In order to increase the effect of the current on the needles, and to enable this effect to be delivered through a great length of intervening wire, Professor Fechner, of Leipsic, suggested, in 1829, enclosing the needles in the multiplier coils of Schweigger. He says, in his *Lehrbuch des Galvanismus* :—"There is

\* *Annales de Chimie et de Physique*, vol. xv. p. 73.

no doubt that if the insulated wires of twenty-four multipliers, corresponding to the several letters of the alphabet, and situated at Leipsic, were conducted underground to Dresden, and there connected to a battery, we could thus obtain a means, probably not very expensive comparatively speaking, of transmitting intelligence from the one place to the other, by means of signals properly arranged beforehand. I confess it is a very seductive idea, to imagine that by some future development of such a system, a communication between the central point and the distant parts of a country can be established, which shall consume no time, like communication between the central point of our organism and its members by means of the nerves, by what appears to be a very analogous arrangement" (p. 269).\*

Acting on this suggestion, Professor Ritchie, of the Royal Institution, London, improved upon Ampère's plan; and, on the 12th of February, 1830, exhibited a model of a telegraph in which were twenty-six metallic circuits and twenty-six magnetic needles, each surrounded by a coil of wire.

The exhibit is thus referred to in the *Philosophical Magazine*, for 1830 (vol. vii. p. 212):—"Feb. 12.—This evening Ritchie briefly developed the first principles of electro-magnetism, with a view of setting forth, in a distinct and practical manner, M. Ampère's proposal of carrying on telegraphic communication

\* See note on p. 239.

by means of this extraordinary power. Of course, the principle consists in laying down wires, which at their extremities shall have coats [coils] of wire and magnetic needles so arranged, that, when voltaic connections are made at one end of the system, magnetic needles shall move at the other. This was done by a small telegraph constructed for the purpose, where, however, the communication was made only through a small distance, the principle being all that could be shown in a lecture-room." \*

In his paper *On a Torsion Galvanometer*, Ritchie refers to the subject in these words:—"We need scarcely despair of seeing the electro-magnetic telegraph established for regular communication from one town to another, at a great distance. With a small battery, consisting of two plates of an inch square, we can deflect finely-suspended needles at the distance of several hundred feet, and consequently a battery of moderate power would act on needles at the distance of a mile, and a battery of *ten* times the power would deflect needles with the same force, at the distance of a *hundred* miles, and one of *twenty* times the force, at the distance of *four hundred* miles, provided the law we have established for distances of seventy or eighty feet hold equally with all distances whatever." †

\* See also *Quarterly Journal of the Royal Institution*, for March 1830, vol. xxix. p. 185.

† *Journal of the Royal Institution*, October 1830, pp. 37-8.

In speaking thus guardedly, the learned professor had evidently in view Barlow's experiments of 1824, which seemed to prove the utter impracticability of all such projects. Barlow then wrote :—" In a very early stage of electro-magnetic experiments it has been suggested [by Ampère] that an instantaneous telegraph might be constructed by means of conducting wires and compasses. The details of this contrivance are so obvious, and the principles on which it is founded so well understood, that there was only one question which could render the result doubtful, and this was, is there any diminution of effect by lengthening the conducting wire? It had been said that the electric fluid from a common electrical battery had been transmitted through a wire four miles in length without any sensible diminution of effect, and to every appearance instantaneously, and if this should be found to be the case with the galvanic circuit then no question could be entertained of the practicability and utility of the suggestion above adverted to.

"I was, therefore, induced to make the trial, but I found such a sensible diminution with only 200 feet of wire as at once to convince me of the impracticability of the scheme."

\* *Edinburgh Phil. Journal*, for 1825, vol. xii. p. 105. It may save some future inquirer a good deal of trouble if we here refer to a supposed early suggestion of an electric telegraph, which we find thus recorded in *Notes and Queries*, for October 30, 1858, p. 359 :—

"In *Notes to Assist the Memory*, 2nd edit., 1827 (the first edition of

Dr. Jacob Green, of Jefferson College, Philadelphia, re-echoed this opinion in 1827; and there can be no doubt that the opinions of such men, so clearly enunciated, and supported by such apparently irrefutable experiments, had the effect of retarding for a while the introduction of electric telegraphs.

1825-37.—*Schilling's Telegraph.*

The invention that we are now about to describe is a very interesting one, not only because it was by far the most practicable of the proposals that had hitherto been made, but because it was the prototype of our well-known needle instruments, and was the immediate cause of the introduction of electric telegraphs into England.

---

which was published in 1819), the following note is added to the article on telegraphs:—‘The electric fluid *has been* conducted by a wire four miles in length, apparently instantaneously, and without any diminution of effect. If this should be found to be the case with the galvanic circuit, *an instantaneous telegraph* might be constructed by means of wires and compasses.’”

Now if this passage occurred in the 1819 edition it would be prior to Oersted's discovery! Our curiosity was aroused in the highest degree, and we instituted a fatiguing search for the book in the British Museum. We found at last a small 12mo volume, of which the following is the full title: *Notes to Assist the Memory in Various Sciences*, London, John Murray, 1825. On the face is written in pencil “By Walter Hamilton, M.R.A.S.” The note above quoted appears on p. 110. This is the only book of the name in the British Museum, and there is no mention anywhere of a previous edition. The writer in *Notes and Queries* must therefore be wrong in his figures, and this will appear all the more certain on comparing the words of the note with those of Barlow, which we give in the text.

According to Dr. Hamel,\* Baron Pawel Lwowitch Schilling (of Canstadt), then an *attaché* of the Russian Embassy at Munich, saw for the first time, on the 13th August, 1810, a telegraph (Sömmerring's) in action, and so impressed was he with the beauty and utility of the contrivance that, from that day, electricity and its applications became one of his most favoured studies. In the following five, or six, years his duties frequently took him to Munich, and at these times he was a constant visitor at Sömmerring's house, whither he delighted to bring his friends from all parts of Europe to witness the performances of the telegraph. Indeed, during much of this time he may be said to have lived in an electrical atmosphere in the society of Sömmerring, Schweigger, and other kindred spirits.

Schilling's first application of electricity was to warlike ends. We learn from Hamel† that the war impending between France and Russia, in 1812, made him anxious to devise a conducting wire which could be laid, not only through moist earth, but through long stretches of water; and which should serve for telegraphic correspondence between fortified places and the field, as well as for exploding powder mines.

So diligently did he work at this task that before the autumn of the same year he had "contrived a

\* *Historical Account of the Introduction of the Galvanic and Electro-Magnetic Telegraph into England*, Cooke's reprint, London, 1859, p. 13.

† Hamel, Cooke's reprint, pp. 20-2.

subaqueous galvanic conducting cord" (a copper wire insulated with a solution of india-rubber and varnish), and an arrangement of charcoal points, by means of which he was able to explode powder mines across the Neva, near St. Petersburg. At Paris, during the occupation of the allied troops, in 1814, he also frequently ignited gunpowder across the Seine with this *electric exploder*, to the great astonishment of the *gamins*.

In the next ten years (1815-25), Schilling divided the spare moments of a busy diplomatic and military career between lithography, an art then recently developed at Munich and which he was anxious to introduce into Russia, and electricity. In these circumstances, then, the surprise is, not that he brought out an electric telegraph of his own construction, but that he did not do so at an earlier date than the one usually assigned. Dr. Hamel vaguely fixes this date at about 1825, for he says that the Emperor Alexander (who died on 1st December, 1825) "had been pleased to notice the invention in its earlier stage."\*

Schilling's apparatus was based on the property of a voltaic current to deflect a magnetic needle. It is sometimes described as a single-needle telegraph, and sometimes as one with five or six needles. What seems probable is that he tried many arrangements, that he first constructed a telegraph with one needle and was thence led on to combine several into one

\* Hamel, Cooke's reprint, p. 41.



system, so as to be able to transmit a number of signals at once.

The signal-indicating part of the single-needle telegraph consisted of an ordinary Schweigger galvanometer. The needle was suspended horizontally by a silken thread, to which was attached, parallel to the

FIG. 12.

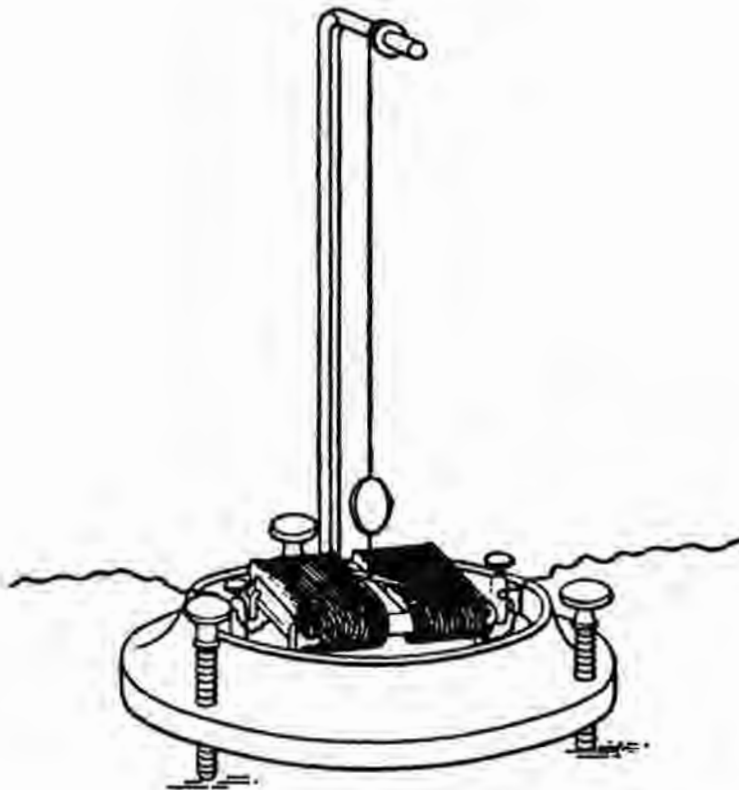

needle, a little disc of paper, painted black on one side, and white on the other. By the deflection of the needle to the right, or to the left, according to the direction in which the current moved in the coil, either face of the disc could be shown at pleasure, and

two primary signals could be thus obtained, whose repetitions variously combined would represent the twenty-six letters of the alphabet, the ten ciphers, and four conventional signs.

The following is Schilling's alphabet as given by Vail, at p. 156 of his *American Electro-Magnetic Telegraph*:\*—

A = bw	N = wb
B = bbb	O = bw b
C = bw w	P = ww b b
D = bb w	Q = ww w b
E = b	R = w b b
F = b b b b	S = w w
G = w w w w	T = w
H = b w w w	U = w w b
I = b b	V = w w w
J = b b w w	W = b w b w
K = b b b w	X = w b w b
L = w b b b	Y = w b b w
M = w b w	Z = w b w w

In order to prevent the prolonged, or violent, swinging of the needle after each deflection, Schilling fixed to the lower extremity of the axle a thin platinum plate, or scoop, which, dipping into mercury placed beneath, deadened the motions, changing what might

\* The bi-signal alphabet is popularly supposed to have come into existence with the Morse telegraph, but, in reality, its invention is almost as old as the hills. It was constantly employed in all kinds of semaphoric, luminous, and acoustic signalling from the days of the Greeks and Romans down to our own time. Lord Bacon gives an example in the 6th book of his *Advancement and Proficiency of Learning*, published in 1605; and a still better one will be found in *Cryptographia Frederici* (p. 234), published in 1685.

otherwise be prolonged oscillations into *dead-beat* movements—a method since adopted in a modified form in some of Sir William Thomson's mirror galvanometers.

As a means of attracting attention, Schilling added a contrivance, the idea of which he clearly borrowed from Sömmerring's alarm. It differed from the instrument that we have been describing only in that

FIG. 13.

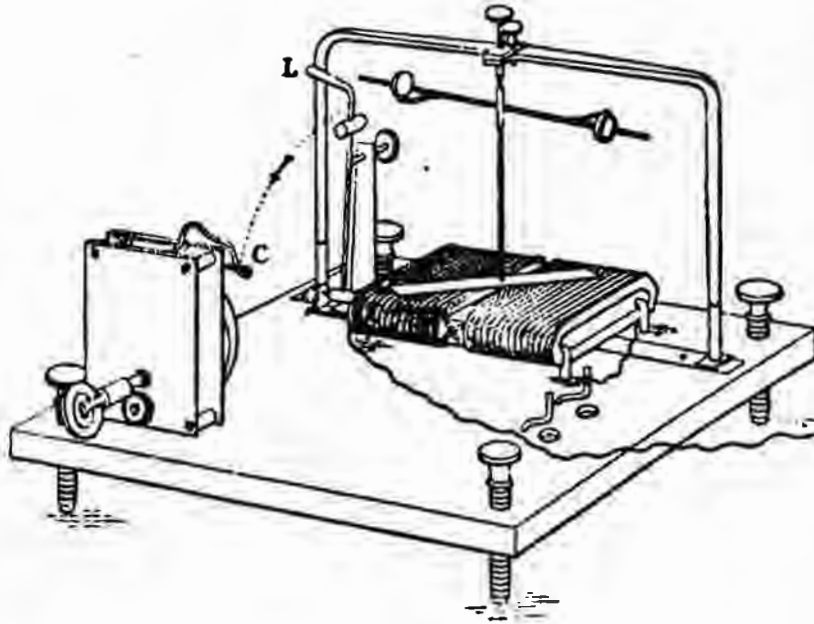

the rod whence the needle was suspended was made of rigid metal (wire), and carried a horizontal arm, which, when the needle was deflected, struck a finely balanced lever, and caused a leaden ball resting upon it to fall upon another lever, and so release the detent of an ordinary clockwork alarm.

At first the currents were transmitted by touching

the ends of the line wires (outgoing and returning) direct to the poles of the battery in one way or another, according to the direction in which the currents were required to flow through the coil. But soon this primitive arrangement was superseded by a simple commutator, consisting of (1) a wooden board having four small holes arranged in a square and filled with mercury, into which dipped, severally, the terminal wires of the battery, and the ends of the line wire; and (2) another similar board provided with a handle on one side, and two metallic strips on the other, the ends of which were turned at right angles to the face of the board. They thus formed bridges which were adjusted to dip into the holes of the first board and so establish connection in one sense or another between the poles of the battery and the ends of the line. As a guide to the operator the top of the second board was painted black and white. This commutator is shown in two pieces in Fig. 14.

These instruments were placed on view by the Russian Government at the Paris Electrical Exhibition of 1881, together with a model of Schilling's six-needle telegraph. We translate the following account of this instrument from *La Lumière Électrique*, for March 17, 1883:—

“This apparatus,” says the official (Russian) description of it, “consists of six multiplier-coils, each enclosing a magnetic needle, suspended by a silken

thread from a copper support. A little above each needle is placed the paper disc, painted black on one side, and white on the other, as in the one-needle telegraph.

FIG. 14.

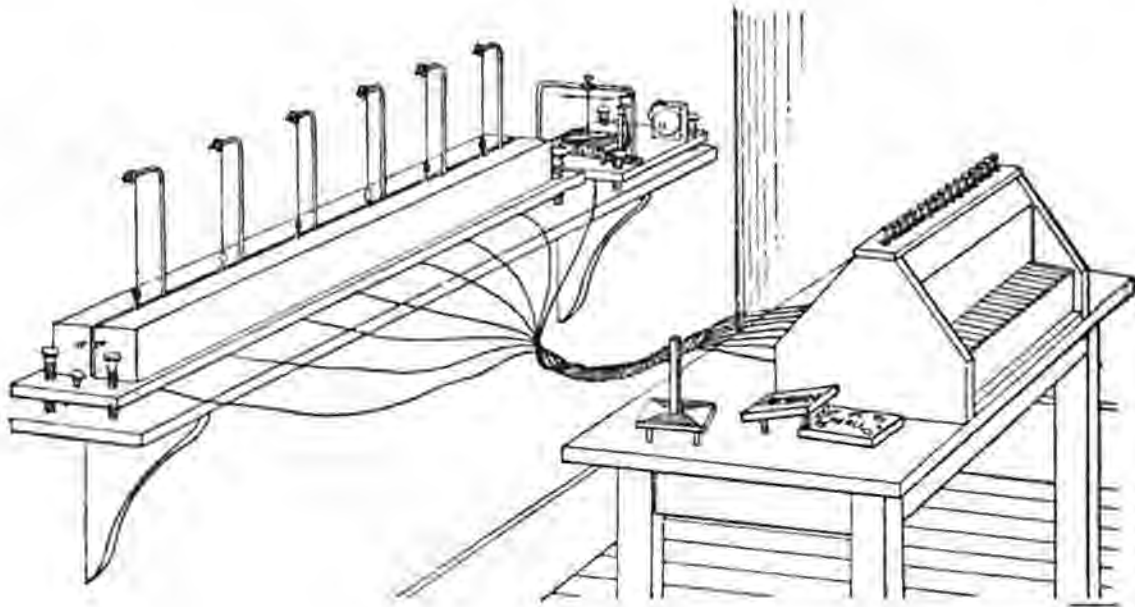

“The sending arrangement consists of a key-board like that of a pianoforte, having sixteen keys, in pairs of one black and one white. Each key, on being depressed, closes the circuit of a galvanic battery, its poles being connected to the lower contacts of the black and white keys respectively. Thus, for example, the negative pole may be connected to all the black keys, and the positive pole to all the white ones. The first six pairs of keys are joined to the six line wires (of copper), which are connected at the distant station to the six multiplier-coils; the seventh pair serves to work the alarum through its

own line wire ; and the eighth and last pair is joined to the return wire."\*

The official account from which we are quoting is very obscurely written, so that it is impossible to gather in what way Schilling proposed to work this telegraph. It would seem that he wished to show from one to six signals at a time, sometimes black, sometimes white, and sometimes both combined ; but he could not effect the latter had he employed only one battery, as the account we are following would have us believe. He must, therefore, have used two separate batteries, and granting this, it is easy to see the immense number of permutations and combinations of which his apparatus was susceptible.

In 1830, Schilling set out for a voyage in China, and took with him a small model of his (? single-needle) telegraph, with whose performances he astonished the natives wherever he went. He returned to Europe in March 1832, and again occupied himself with telegraphic experiments, and hence, possibly, the date, 1832, which many writers assign to his inventions.†

\* A short length of the original wires was shown in connection with the apparatus at the Paris Exhibition. There were eight copper wires, each separately insulated by a coating of resin, and all afterwards made up into a cable and bound with hemp also soaked in resin.

† Besides this error in date, it is often stated that Schilling employed *vertical* needles, that there were thirty-six of them, enclosed in as many multiplier-coils ! and that the line wires (? thirty-six also) were of *platinum* !! insulated with silk. All these mistakes are contained in one short paragraph, which originally appeared in the *Journal des*

In May 1835, he started for a tour in southern and western Europe, taking with him a working model of his one-needle telegraph. At Vienna, he engaged in a series of experiments upon it in conjunction with Baron Jacquin and Professor A. von Ettingshausen. Amongst others they tried the comparative merits of leading the wires over the roofs of the houses, and burying them in the earth. The result was, as may be supposed, in favour of the former plan, for, owing to the defective insulation afforded by a thin coating of india-rubber and varnish, the earth, in the latter case, conducted the current from one wire to the other which lay parallel to it, and at a little distance.\*

In September 1835, he attended the meeting of German naturalists at Bonn, and there, on the 23rd instant, exhibited his apparatus before the Section of Natural Philosophy and Chemistry, over which Professor Muncke, of Heidelberg, presided. Muncke was so pleased with its performance that he had a model made for exhibition at his own lectures at Heidelberg; and other members of the Congress took away with them to their respective homes such wonderful

---

*Travaux de l'Académie de l'Industrie Française*, for March 1839, p. 43, and which has since been copied unquestioningly into nearly every history of the telegraph that we have seen.

\* These experiments are always described as if they had reference to an entirely new system of telegraph, the invention of Jacquin and Ettingshausen (see Dr. Hamel's *Historical Account*, &c., p. 60, Cooke's reprint). Andreas von Ettingshausen, a physicist of European fame, died at Vienna, May 25, 1878, aged eighty-two years.

accounts of its action that Schilling's telegraph was henceforth an object of great curiosity, and became a stock subject for popular lectures, and for articles in all the scientific papers of the period.

Dr. Hamel tells us\* that, on his return home from Germany in 1836, Schilling received two letters urging him to bring his inventions to England, but he declined the suggestion, saying that he preferred to try to introduce them first in his own country. He was soon after honoured by a visit from the Emperor Nicholas, who witnessed with the greatest interest the performances of the telegraph "through a great length of wire," and ended by expressing the desire of having it established between St. Petersburg and Peterhoff. "Of all the high dignitaries," says Jacobi, "who surrounded him, His Majesty was the only one who foresaw the future of what was then looked on only as a toy." †

As was the custom in such cases, a commission of inquiry was appointed, which consisted of Lieut.-General Shubert, Adjutant-General Count Klein-

\* In his lecture on *The Telegraph and Baron Paul Schilling*, before the Imperial Academy of Sciences, St. Petersburg.

† Du Moncel's *Traité Théorique et Pratique de Télégraphie Électrique*, Paris, 1864, p. 217. Yet Russia was one of the last countries to adopt, generally, the electric telegraph. Why? "Because the Emperor Nicholas saw in it only an instrument of subversion, and by a *ukase* it was, during his reign, absolutely prohibited to give the public any information relative to electric telegraph apparatus, a prohibition which extended even to the translation of the notices respecting it, which, at this time, were appearing in the European journals."—Colonel Komaroff's *La Presse Scientifique des Deux Mondes*, as quoted in the *Annales Télégraphiques*, for November-December 1861, p. 670.



Michel, and Flugel-Adjutants Heyden and Treskine, with Prince Alexander Menshikoff as president. Schilling, in due course, submitted his plans, and gave the commissioners a choice of two modes of effecting the communication—(1) either the wires should be covered with silk and varnished, then bound together, tarred, and deposited along the bottom of the Gulf of Finland, or (2) “foreseeing the difficulties of such a plan, they were to be suspended on posts erected along the Peterhoff Road.”\*

An experimental telegraph was set up at the Admiralty, the line consisting partly of overground, and partly of “cable,” which was submerged in the canal. The ends of the line with the appropriate instruments were placed at a great distance apart, one being at the window of Prince Menshikoff’s study, in the N.W. corner of the building, and the other in a room near the great entrance of “the building office.”

The results appear to have been eminently successful, for, in due course, Prince Menshikoff presented to the Emperor a most favourable report, upon the strength of which an Imperial Decree was issued (in May 1837), ordaining the establishment of a telegraph to connect Cronstadt with the capital by

\* Du Moncel, p. 217. Jacobi, whom Du Moncel is quoting, says:—“The latter proposition was received by the Commission with shouts of derision, one of the members saying in my presence, ‘Your proposition is foolish, your wires in the air are truly ridiculous.’” We wonder what he would say, could he take a walk through some of our London streets, where alas! this *folly* has attained to *ridiculously* gigantic proportions.

means of a "cable," laid along the bottom of the Gulf of Finland. But Schilling died on the 6th of August, 1837, and he and his country missed the glory of establishing not only the first really practicable telegraph, but also the first submarine line.\*

1833-8.—*Gauss and Weber's Telegraph.*

In this year Messrs. Gauss and Weber constructed an apparatus at Göttingen, which, although at first intended for purely scientific purposes, soon came to be employed as a means of ordinary correspondence as well. The telegraph, as we must call it, contrived by these well-known physicists is remarkable for three reasons—1st, as being the first in which magneto-electricity was used; 2nd, for the ingenious, yet simple, method of increasing the deviations of the signalling needle—a plan which was long afterwards adopted by Sir William Thomson in his beautiful mirror galvanometers; † and last, though not least, for having had an *actual* existence for several years, during which it rendered most excellent service.

The line, consisting of two copper wires, main and

\* Of course a wire insulated with (1) a thin coating of india-rubber and varnish, as in the Neva and Seine experiments of 1812-14; or (2) with resin, and hemp saturated with resin, as in the "cable" shown at the Paris Exhibition of 1881; or (3) with silk varnished and tarred, as just mentioned, would not last long, but necessity is the mother of invention, and practice makes perfect. The cable laid from Dover to Calais in 1850 was only a little less crude.

† As early as 1826 Poggendorff applied a mirror to the magnetic needle for accurately determining minute variations in its horizontal declination.—Pogg. *Ann. der Phys. und Chem.*, vol. vii. pp. 121-30.

return, was carried upon posts over the houses, and extended from the Physical Cabinet to the Observatory; whence, in 1834, it was continued to the Magnetic Observatory of Professor Weber—a distance

FIG. 15.

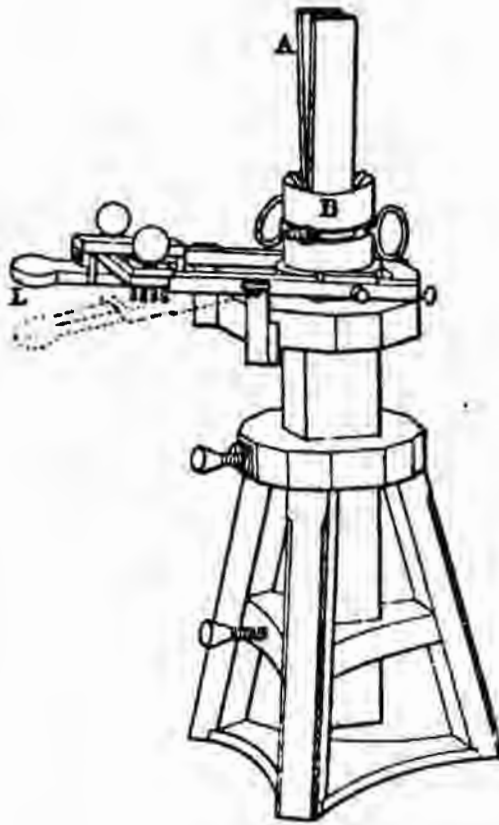

altogether of one mile and a quarter English. An ordinary voltaic pair was employed for generating the current until 1835, when it was replaced by a magneto-electric machine made by Steinheil of Munich.\*

\* In our account of Gauss and Weber's telegraph, we follow Sabine's *History and Progress of the Electric Telegraph*, London, 1869, 2nd edit., pp. 33-8; and *La Lumière Électrique*, for March 17, 1883, p. 334. See also Pogg. *Ann.*, xxxii. 568; and Dingler's *Journal*, lv. 394.

This instrument, called the *Inductor*, consisted of a compound two-bar magnet A, Fig. 15, weighing 75 lbs., fixed vertically on a stool; a wooden bobbin B, supplied with a handle L, and wound with 3500 turns (and later with 7000 turns) of insulated copper wire (No. 14, silvered), rested on the stool and encircled the magnet, as shown in the figure. On lifting the bobbin by depressing the handle, a momentary current would be induced in the coil in one direction, and on lowering it again to its position of rest another momentary current would be induced in the opposite direction. The ends of the coil B, were connected through the commutator, Fig. 17, to the line wires, and the distant ends of these were similarly joined to the ends of the coil of the receiver.

The receiver, shown in Fig. 16, consisted of a large copper frame B, B,\* upon which was wound 3000 feet of insulated copper wire, like that of the inductor. A permanent magnet A, 18 inches long, and 3" × 5" transverse section, and weighing one hundred pounds,

\* The copper frame, which Gauss called *the damper*, was necessary in order to prevent the great number of oscillations which the magnet would have made across the meridian had no such check been introduced. The checking action of masses of metal, and indeed of any other solid or liquid substance, in the vicinity of an oscillating magnet was discovered by Arago, in 1824. Sir William Snow Harris found that the oscillations of a freely suspended magnetic needle were reduced, from 420 without a damper, to 14 with a damper. In the present case the great mass of the magnet and the minuteness of the deviation must have aided materially in bringing it quickly to a state of rest. See pp. 282-3 *ante*.

was suspended, in the interior of the coil, by a number of untwisted silk fibres, from a hook above it. To enable the observer to read off with care the minute

FIG. 16.

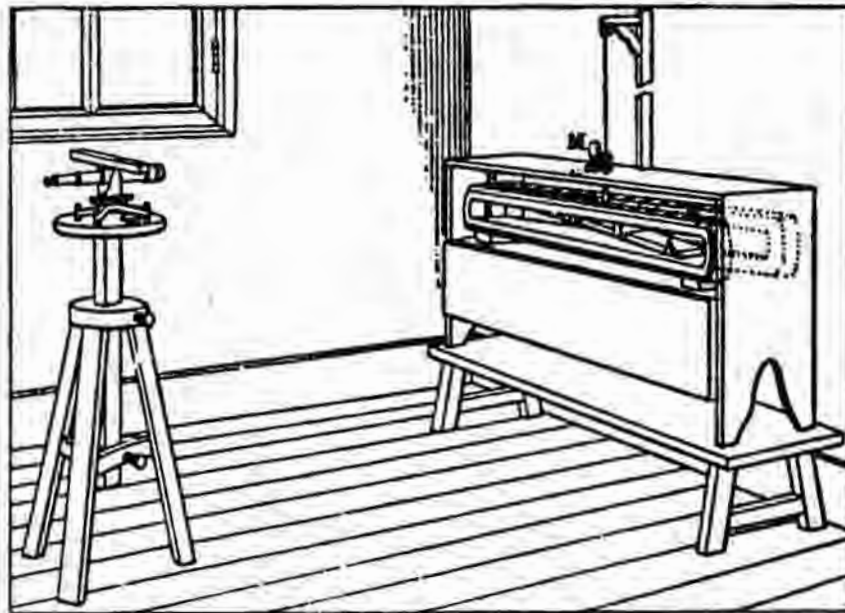

deviations of the magnet, a small mirror *M*, was affixed to the supporting shaft, and in this was seen, through a telescope, at ten or twelve feet distance, the reflection of a scale placed above it. Notwithstanding the weight of the magnet, its movements were thus made beautifully energetic and distinct, a very small force, such as that supplied from a single cell, causing a deviation of over a thousand divisions of the scale.

The commutator, by means of which the electric currents were directed through the line wires in one sense or another, was similar to that of Schilling,

being simply an arrangement for bringing two points alternately in communication with two others. Let  $a$ , and  $c$ , Fig. 17, be two points in connection with the two poles of a battery, or other electromotive system, and  $b$ , and  $d$ , the ends of any other circuit; if the metal bars  $e$ , and  $f$ , be pressed upon the ends  $a$ ,  $b$ , and  $c$ ,  $d$ , respectively, the current will pass in the direction  $B + a e b R d f c - B$ . But if the bars  $e$ , and  $f$ , be removed from these positions and placed at right angles, that is to say,  $e$ , between  $b$ , and  $c$ , and  $f$ , between  $a$ , and  $d$ , as shown by the dotted lines, the current will go through  $B + a d R$  (in the opposite direction)  $b c - B$ .

FIG. 17.

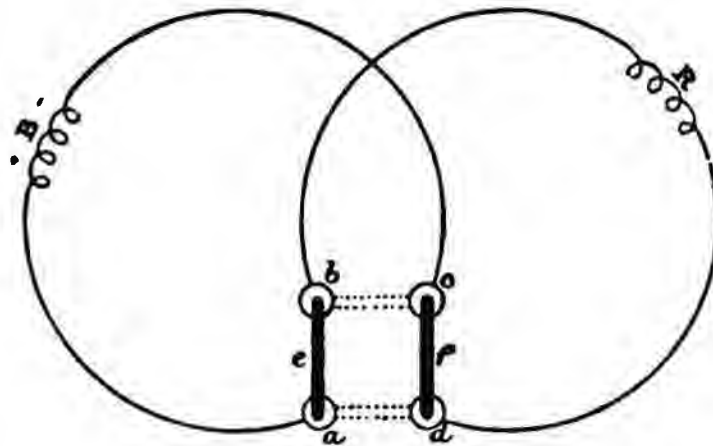

The *modus operandi* was as follows :—On lifting up the coil B, Fig. 15, by depressing the handle L, to the position shown by the dotted lines, a current was induced in the wire. This current passed by the commutator, placed as in Fig. 17, from  $a$ , to  $b$ , through one of the line wires and the multiplier R, of the

receiving station, deflecting the magnet for an instant in one direction, and returned by the other wire over *d*, and *c*, of the commutator. When it was wished to deflect the needle of the receiving instrument in the opposite direction, this was attained by simply lowering the coil B, again to its original place, and the observer at the receiving station read off one deflection to the right for instance, and one to the left. But, in constructing a code of signals, it was necessary that two or more deflections to the right or left should frequently follow each other. This was done by means of the commutator. Thus, on lifting the coil, if we suppose a deflection of the magnet was produced to the right, by reversing the commutator and then lowering the coil again, another deflection in the same direction would be observed. To produce a third deflection in the same direction it would be necessary, evidently, to reverse the commutator again before raising up the inductor. After this fashion Gauss and Weber were enabled, by combining the deflections to the right and to the left, to form the following alphabet and numerals, with a maximum of four elementary signals :—

<i>r</i> = <i>a</i>	<i>rlr</i> = <i>f, v</i>	<i>rrlr</i> = <i>s</i>	<i>lrir</i> = <i>3</i>
<i>l</i> = <i>e</i>	<i>lrr</i> = <i>g</i>	<i>rlrr</i> = <i>t</i>	<i>llrr</i> = <i>4</i>
<i>rr</i> = <i>i</i>	<i>lll</i> = <i>h</i>	<i>lrrr</i> = <i>w</i>	<i>lllr</i> = <i>5</i>
<i>rl</i> = <i>o</i>	<i>llr</i> = <i>l</i>	<i>rrll</i> = <i>s</i>	<i>llrl</i> = <i>6</i>
<i>lr</i> = <i>u</i>	<i>lrl</i> = <i>m</i>	<i>rlrl</i> = <i>o</i>	<i>lrll</i> = <i>7</i>
<i>ll</i> = <i>b</i>	<i>rll</i> = <i>n</i>	<i>rllr</i> = <i>1</i>	<i>rlll</i> = <i>8</i>
<i>rrr</i> = <i>c, k</i>	<i>rrrr</i> = <i>p</i>	<i>lrll</i> = <i>2</i>	<i>llll</i> = <i>9</i>
<i>rll</i> = <i>d</i>	<i>rrrl</i> = <i>r</i>		

$r$ , represents the swing of the north pole of the magnet towards the right, and  $l$ , the swing of the same pole towards the left of the magnetic meridian. Various lengths of the pauses between the signals indicated the conclusion of words and sentences.

In 1835, an alarm was added, which, according to some accounts, consisted in giving to the magnet A, Fig. 16, a more than ordinary deviation, and so making it strike a bell ; while, according to others, it it was very similar to that of Schilling, the magnet, when largely deflected, upsetting a delicately-poised lever in train with the detent of an ordinary clockwork alarm.

Gauss and Weber's apparatus was in daily use for telegraphic and astronomical purposes down to the year 1838.



## CHAPTER XII.

TELEGRAPHS BASED ON ELECTRO-MAGNETISM AND  
MAGNETO-ELECTRICITY (*continued*).1836.—*Steinheil's Telegraph.*

THE apparatus last described was, as we have said, established for other than telegraphic purposes, and it was for this reason, that Gauss, unable himself to afford the time, invited Steinheil, of Munich, to pursue the subject, and endow with a practical form an invention which he believed capable of great results.

The perfection to which this ingenious inventor brought Gauss and Weber's telegraph has rendered it as much, or more his than theirs. His own estimate, however, of the changes effected in the telegraph erected at Munich towards the end of 1836, is very modest and is worth quoting:—"To Gauss and Weber," he says, "is due the merit of having actually constructed the first simplified galvano-magnetic telegraph. It was Gauss who first employed magneto-electricity, and who demonstrated that the appropriate combination of a limited number of signs is all that is

required for the transmission of intelligence.\* Weber's discovery that a copper wire 7460 feet long, which he had led across the houses and steeples of Göttingen, required no special insulation, was one of great importance, and at once established the practicability of a galvanic telegraph in a most convenient form.

“All, therefore, that was required was (1) an appropriate method of inducing, or exciting, the galvanic current, with the power of changing its direction without the need of any special contrivances; and (2) a mode of rendering the signals audible [or legible]. The latter was a task that apparently presented no very particular difficulty, inasmuch as in the very scheme itself a mechanical motion—namely, the deflection of a magnetic bar—was given. All that we had to do, therefore, was to contrive that this motion should be made available for striking bells, or for marking indelible dots.

“This falls within the province of mechanics, and there are, therefore, more ways than one of solving the problem. Hence the alterations that I have made in the telegraph of Gauss and Weber, and by which it has assumed its present form, may be said to be founded on my perception and improvement of its imperfections. I by no means, however, look on the arrangement I have selected as complete; but as it

\* Steinheil was apparently unaware of all that Baron Schilling had done in this direction.

answers the purpose I had in view, it may be well to abide by it till some simpler arrangement is contrived." \*

We condense the following account of Steinheil's apparatus from an English translation of the author's own classical memoir, which appeared in Sturgeon's *Annals of Electricity*, for March and April, 1839.†

\* To Steinheil's lasting honour be it said, that when some ten years later "a simpler arrangement" in the shape of Morse's telegraph was brought to his attention he was the first to appreciate it, and to urge upon the Bavarian Government its adoption, to the abandonment of a portion of his own beautiful system.

*Apropos* of this, we find an amusing story in Reid's *Telegraph in America*, pp. 85-6:—"The (Morse) relay could not be patented in Germany, and, therefore, could not with safety be exposed. In 1848, two young Americans had gone there with Morse machinery, and built a line from Hamburg to Cuxhaxen, a distance of 90 miles, for the transmission of marine news. The line worked charmingly, the registers clicked out loud and strong at either end, but the relays were carefully concealed in locked boxes. The German electricians scratched their heads and wondered. Finally Steinheil was sent forward to reconnoitre; he looked carefully around, and his keen eyes soon detected the locked boxes. He asked to see their contents, but the view was courteously declined. So he returned and reported that the Yankees kept their secret locked, but that the action was magnificent. And when at a later date he *did* know all, he showed the grand stuff of which he was made. He gave Morse his hand, confessed himself beaten, and the two were friends for ever after."

† Vol. iii. pp. 439-52, and 509-20. See also *Comptes Rendus*, September 1838; and Shaffner's *Telegraph Manual*, New York, 1859, pp. 157-78. Shaffner says that "the first published notice of this important invention will be found in the third volume of *The Magazine of Popular Science*, in a letter from Munich, under date December 23, 1836." This letter appears on pp. 108-10; is chiefly concerned with electro-magnetic experiments; and in the last two paragraphs briefly mentions Steinheil's telegraph.

“The telegraph is composed of three principal parts :—

1. A metallic connection between the stations.
2. The apparatus for exciting the galvanic current.
3. The indicator, or receiving apparatus.

*1. Connecting Wire.*

“This so-called connecting wire may be looked on as the wire completing the circuit of a voltaic battery extended to a very great length. What applies to the one holds good of the other. With equal thicknesses of the same metal, the resistance offered to the passage of the galvanic current is proportional to the length of the wire ; and with equal lengths of the same metal, the resistance diminishes inversely with the section. The conducting power of metals is very different. Thus, according to Fechner, copper conducts six times better than iron, and four times better than brass, while the conducting power of lead is even lower ; so that the only metals which can well vie with each other in their technical use are copper and iron. But although iron is about six times as cheap as copper, it will be requisite to give the iron wire six times the weight of a copper one to gain the same conducting power with equal lengths. We thus see that as far as the expense is concerned it comes to the same thing, whichever of these metals is chosen. The preference

will be given to copper, as this metal is less liable to oxydation from exposure to the atmosphere.

“This latter difficulty may, however, be surmounted by simple means, *viz.*, by galvanising the iron. It would even appear that the simple transmission of the galvanic current, when the telegraph is in use, is sufficient to preserve the iron from rust; such at least is observed to be the case with the iron portion of the wire used for the telegraph here, and which has already been exposed in all weathers for nearly a twelvemonth.

“If the galvanic current is to traverse the entire metallic circuit without any diminution of strength, the wire during its whole course must not be allowed to come into contact with [*i. e.*, short-circuit] itself; neither should it be in frequent contact with semi-conductors, for, since the power called into action always completes its circuit by the shortest course, the remote parts of the wire would be thus deprived of a portion of the current.

“Numerous trials to insulate wires and to lay them below the surface of the ground have led me to the conviction that such attempts can never answer at great distances, inasmuch as our most perfect insulators are at best but very bad conductors. And since in a wire of very great length, its surface in contact with the so-called insulator is uncommonly large when compared with its section, there necessarily must arise a diminution of the force, inasmuch as the

outgoing and returning wire, although but slightly, yet *do* communicate in intermediate points.\*

“It would be wrong to think that this difficulty could be got over by placing the two wires very far apart. The distance between them is, as we shall see in the sequel, almost a matter of indifference. As, then, we shall never succeed in laying down conductors that are sufficiently insulated beneath the surface of the ground, there is but one other course open to us, *viz.*, leading them through the air. Upon this plan, it is true, the conductor must be supported from time to time, is liable to be injured by the evil disposed, and is apt to suffer from violent storms, or from ice which forms upon it. As we, however, have no other method that we can avail ourselves of, we must endeavour by suitable arrangements to get the better of these difficulties in the best way we can.

“The conducting chain of the telegraph erected here consists of three parts—one leads from the Royal Academy to the Royal Observatory, at Bogenhausen, and back. The total length of its wire is 32,506 feet, and the weight amounts to 260 lbs. [*sic*]. Both wires (there and back) are stretched across the steeples of the town at a distance apart of 4 feet 1 inch. The distance from support to support ranges from 640 to 1279 feet: this is undoubtedly far too great for a single-strand wire, inasmuch as the ice that forms

\* It should be remembered that when Steinheil wrote, gutta-percha and india-rubber were both unknown as insulators.

upon it materially increases its weight, and considerably augments its diameter, so that it becomes liable to be torn asunder by high winds.\* Over those places where there are no high buildings the wire is supported upon poles forty or fifty feet high, which are let five feet into the ground, and at the top of which it is fastened by twisting on cross wooden bars. At the points of support the wire rests on pieces of felt.

“ The conducting wire thus mounted is by no means completely insulated. When, for example, the circuit is broken at Bogenhausen, an induction-shock given in Munich ought to produce no galvanic excitation whatever in the parts of the chain then disconnected, yet Gauss's galvanometer gives indication of a weak current. Measurements, indeed, go to show that this current goes on increasing, as the point at which the interruption of the stream is made recedes from the inductor. The total amount of this current [leakage] is not constant, being, generally, greatest in damp weather.

“ At moderate distances of a few miles this loss of power is of almost no importance, more especially as the construction of the inductor places currents of almost any strength we choose at our command. When the distance, however, amounts to upwards of

\* All these evils could be got over by making the connection by at least a triple strand (and not by a single wire), supporting it at intervals of 300 feet, and giving it a tension not exceeding one-third of what it would bear without giving way. This, however, in the experimental telegraph erected here, was not practicable.

200 miles [*sic*], the greatest part of the effect would be dissipated. In such cases, therefore, much greater precaution must be taken with regard to the points of support of the metallic circuit.\*

“A second portion of the conducting chain leads from the Royal Academy to my house and observatory in the Lerchenstrasse. This is of iron wire, its length, there and back, is 5745 feet, and it is stretched over steeples and other high buildings, as has already been described.

“Lastly, a third portion of the chain, running through the interior of the buildings connected with the Royal Academy, leads to the mechanical workshop attached to the cabinet of Natural Philosophy. It is composed of a fine copper wire 598 feet long, let into the joinings of the floor, and, in part, imbedded in the walls.

## 2. *Apparatus for Generating the Galvanic Current.*

“Hydro-galvanism, or the galvanic current generated by the action of the voltaic pile, is by no means fitted for traversing *very long* connecting wires, because the resistance in the pile, even when many hundred pairs of plates are employed, would be always inconsiderable compared with the resistance offered by the wire itself. The principal disadvantages, however,

\* When thunder-storms occur, atmospheric electricity collects on this semi-insulated chain as upon a conductor, but the passage of the galvanic current is not at all affected thereby.



attendant on the use of the pile, or trough apparatus, are (1) the fluctuations of its current, and (2) its speedy loss of power.

“All these difficulties are got over by having recourse to Faraday’s important discovery of magneto-electric induction, that is to say, by moving magnets in the neighbourhood of conducting coils. The better way is, not to move the magnets as Pixii does, but rather to give motion to coils of wire in close proximity to a fixed magnet. This arrangement, known as Clarke’s, is the one which with some modifications we have adopted.

“The magnet is built up of seventeen horse-shoe bars of hardened steel, Fig. 21. With its iron armature its weight is about 74 lbs., and it is capable of supporting about 370 lbs. Between the arms, or poles, is fastened a piece of metal which supports the axis on which the coils revolve. These coils, of which there are two, have in all 15,000 turns of silk-covered wire, a metre of which weighs  $15\frac{1}{2}$  grains. The two ends of the wire are passed up through the interior of the axis, and terminate in two hook-shaped pieces which just dip into semicircular cups of mercury, separated from each other by a wooden partition. From these cups there proceed short wires to which the line wires are connected. The mercury, owing to its capillarity, stands at a higher level in the cups than the partitions, so that the terminal hooks pass over the latter without touching them whenever the coils

are revolved. The hooks are thus brought into the cups alternately at every half turn of the coils, and as a consequence the induced current preserves its sign as long as the coils are turned in one direction, and changes it on the motion being reversed. The current, as we shall see when treating of the indicator, should only be permitted to act during as short a time as possible, while during that time it should have the greatest intensity we can give it. To effect this the mercury cups are arranged as shown in the dark portion of Fig. 18. The terminal hooks travel in the white annular space, and make contact only at the moments when passing over the points *a*, and *b*.

FIG. 18.

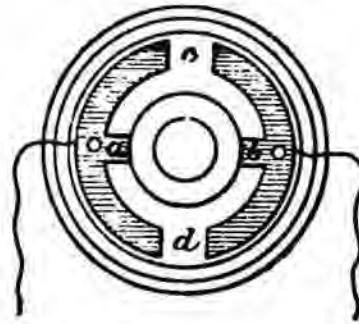

“ In order to cut off the inductor when not in action, its axis is made to carry a cross-piece of metal, at right angles to the terminal hooks of the coils, which, when the inductor is at rest, dips into the mercury cups. Whence it follows that the current, on being transmitted from any other station, passes directly from one cup to the other without traversing the wire of the inductor coils. In order to put the coils in motion without trouble a fly-bar terminating in two metal balls is attached horizontally to the vertical axis of the coils (see Fig. 21).

“ At every half turn a spark occurs as the hooks of

the coils leave the mercury. As this is for many reasons objectionable, we have latterly designed a commutator of a far simpler construction. The ends of the coil are in this case fastened to two strips of copper let into the periphery of a wooden ring, directly opposite each other. This ring is placed upon the axis of the coils and made fast to it by clamps, and the two ends of the line wire are so disposed as to press like springs against the copper strips as the coils are revolved. With this arrangement the ends of the coils are in metallic connection with the line only during a small portion of each revolution, while during the rest of the time the metal cross-piece, with which also the wooden ring is provided, brings the two ends of the line wire into direct connection. This form of commutator, in which mercury is entirely dispensed with, is, on account of its greater simplicity and durability, preferable to the arrangement just described, and is employed in the apparatus of the stations at Bogenhausen and in the Lerchenstrasse.

### 3. *The Indicator.*

“ Figs. 19 and 20 represent vertical and horizontal sections of the indicator, containing two magnets, movable on axes *m*, *m*, and which from their construction are applicable either to strike bells, or to note down signals. Round a frame formed of sheet

brass are wound six hundred turns of the same insulated copper wire as is used in the inductor. The magnetic bars are, as Fig. 20 shows, so placed that the north pole of the one is presented to the south

FIG. 19.

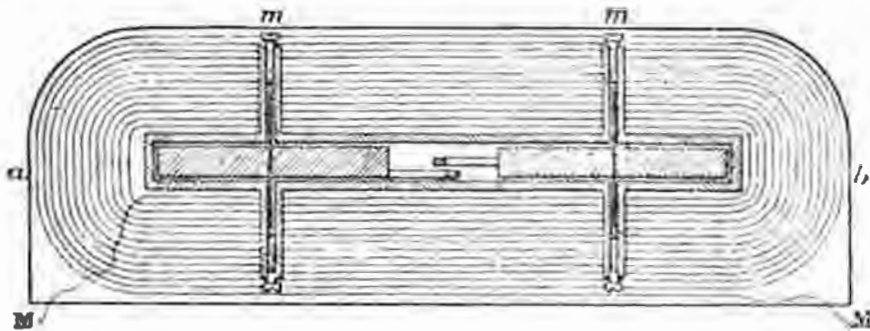

pole of the other. To these ends are screwed two slight brass arms, supporting little cups which are provided with extremely fine perforated beaks *c, c*

FIG. 20.

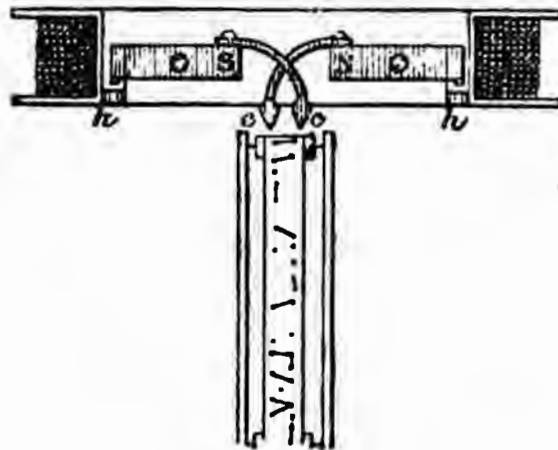

When printing ink is put into these cups it insinuates itself into the beaks owing to capillary attraction, and, without running out, forms at their orifices a

z

projection of a semi-globular shape. The slightest contact, therefore, suffices for noting down a black dot.

“Two plates, or pins, *h, h*, prevent the magnets from being deflected in a direction opposite to that in which they are to print, as the deflection by the current would otherwise cause them to swing, and, perhaps, record false dots while thus oscillating. As a further check to these oscillations, and in order to bring back the bars quickly to their normal positions after each deflection, recourse is had to smaller movable magnets (Fig. 21) whose distance and position with regard to the others are to be varied until the desired effect is produced. Owing to the disposition of the magnet bars and the controlling action of the pins *h, h*, a current sent through the coil deflects only one magnet at a time, the other being simply pressed tightly against its pin; and on the current being reversed, the reverse takes place, the last-mentioned magnet being deflected, while the first is held back.

“Much nicety is required in obtaining the magnets of exactly the right size. They must not, for example, be too large, because their inertia would be too great; nor too small, because then their mechanical force would not be sufficient for printing or sounding the signals.

“For the recording of the signals, a flat surface of paper must be kept moving with a uniform velocity in front of the little beaks, Fig. 21. The best way of doing this is to employ very long strips of the so-called

endless paper which is to be wound round a cylinder of wood and then cut upon the lathe into bands of suitable width. One of these strips of paper must be made to unwind itself from a cylinder, pass close in

FIG. 21.

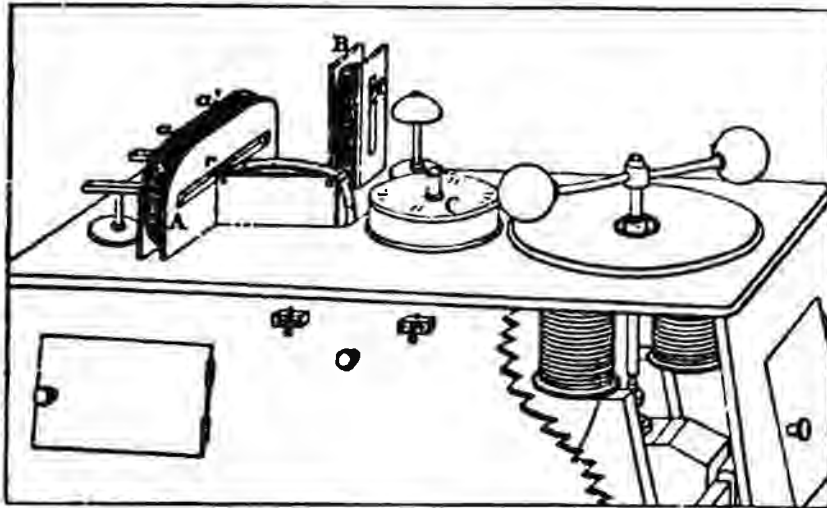

front of the beaks, run along a certain distance in a horizontal position, so that the dots noted down may be read off, and lastly wind itself up again on to a second cylinder. This second cylinder is put in motion by clockwork, the regularity of whose action is insured by a centrifugal fly-wheel.

“If this apparatus be employed for producing two sounds easily distinguishable to the ear by striking on bells, it will be right to select clock-bells, or bells of glass, both of which easily emit sounds, and whose notes differ about a sixth. This interval is by no means a matter of indifference. The sixth is more easily distinguished than any other interval; fifths

and octaves would be frequently confounded by those not versed in such matters. The bells are to be supported on little pillars, and their position with respect to the bars is to be determined by experiment. The knobs let into the bars for striking the bells must give the blow at the place which most easily emits a sound. They are not, however, to be too close to the bells, as in that case a repetition of the signal can easily ensue. A few trials will soon get over this difficulty.

“It is evident that the same magnetic bars cannot be at once employed for striking bells and for writing, the little power they exert being already exhausted by either of these operations. But to combine them both, all we have to do is, to introduce a second indicator coil into the chain; this can, however, only be done at the cost of an increased resistance, and, in order that this increase may be as little as possible, it would in future be better that the coils of the indicator should be made of very thick copper wire, or of strips of copper plate. Fig. 21 shows two coils in circuit, the one marked B, being used as an alarm [which no doubt the attendant could short-circuit after replying to its call].

“At the central station in the Physical Cabinet a commutator, C, Fig. 21, is placed which enables us by simple transpositions to effect the following changes in the wires and apparatus:—

“(1.) The currents emanating at the central station

traverse the receiving instruments of both the Bogenhausen and Lerchenstrasse stations at the same time.

“(2.) The currents traverse the Lerchenstrasse line and instrument only, and the Bogenhausen line is connected through the receiving instrument of the central station, so that while one attendant at the latter station is *sending to* Lerchenstrasse, another attendant may be *receiving from* Bogenhausen.

“(3.) Is the reverse of the last-named arrangement.

“(4.) Bogenhausen and Lerchenstrasse are joined direct, and the apparatus at the Physical Cabinet cut out of circuit altogether.

“We have said before that at every half turn of the fly-bar from (say) *right to left*, one of the magnets of the indicator is deflected. Now we have so connected the apparatus that every time this movement takes place the high-toned bell should be struck, if the receiver be arranged as an acoustic instrument; or the corresponding beak shall print a dot on the paper strip, if the receiver be arranged as a recording instrument. On turning the fly-bar from *left to right*, the low-toned bell sounds, or the corresponding beak prints a dot, not upon the same line as the first, but on a lower one. High tones, therefore, correspond with the dots on the upper line, and low tones with the dots on the lower line, as in a musical score.

“As long as the intervals between the sounds or the signs remain equal, the said sounds or signs are to be read together as one signal, a longer interval indicates



the completion of a letter or signal. We are thus enabled by appropriately selected groups to represent all the letters of the alphabet, or stenographic characters, and thereby to repeat and render permanent at all parts of the chain where an apparatus like that above described is inserted any information that we choose. The alphabet that I have chosen represents the letters that occur the oftenest in German by the simplest signs. By the similarity of shape between these signs and that of the Roman letters, they become impressed upon the memory without difficulty. The distribution of the letters and numbers into groups consisting of not more than four dots is shown below.

FIG. 22.

A . . . . . ●●●●	L . . . . . ●●●●	0 . . . . . ●●●●
B . . . . . ●●●●	M . . . . . ●●●●	1 . . . . . ●●●●
C, K . . . . . ●●●●	N . . . . . ●●●●	2 . . . . . ●●●●
D . . . . . ●●●●	O . . . . . ●●●●	3 . . . . . ●●●●
E . . . . . ●●●●	P . . . . . ●●●●	4 . . . . . ●●●●
F . . . . . ●●●●	R . . . . . ●●●●	5 . . . . . ●●●●
G . . . . . ●●●●	S . . . . . ●●●●	6 . . . . . ●●●●
H . . . . . ●●●●	T . . . . . ●●●●	7 . . . . . ●●●●
Ch . . . . . ●●●●	U, V . . . . . ●●●●	8 . . . . . ●●●●
Sch . . . . . ●●●●	W . . . . . ●●●●	9 . . . . . ●●●●
J . . . . . ●●●●	Z . . . . . ●●●●	

“Messages were printed with this apparatus at the rate of ninety-two words in a quarter of an hour, or over six words per minute.”

*Discovery of the Earth Circuit.*

In order not to interrupt the continuity of our description of Steinheil's beautiful apparatus, we have reserved for a special paragraph our notice of this most important discovery.

As we have seen in our second, third, fourth, and fifth chapters, the earth circuit was used, with few exceptions, in all experiments with static electricity. Its function, however, was either unsuspected or misunderstood.\* Of all the telegraphic proposals based on static electricity, those of Bozulus, 1767, and of the anonymous Frenchman, 1782, are the only ones in which complete metallic circuits were proposed. Reusser, 1794, used one common return wire; while all the others employed the earth, Volta, Cavallo, and Salvá making distinct mention of their doing so.

The power of the earth to complete the circuit for dynamic electricity has also been known for a very long time. Thus, on the 27th of February, 1803, Aldini sent a current from a battery of eighty silver and zinc plates from the West Mole of Calais harbour to Fort Rouge through a wire supported on the masts of boats, and made it return through 200 feet of intervening water.†

Basse, of Hamel, made similar experiments, and

\* As in Watson's experiments, described at pp. 111-13 of Priestley's *History of Electricity*, 1767.

† Aldini's *Account of late Improvements in Galvanism*, London, 1803, p. 218.

about the same time, on the frozen water of the ditch, or moat, surrounding that town. He suspended 500 feet of wire, on fir posts, at a height of six feet above the surface of the ice, then making two holes in the ice and dipping into them the ends of the wire, in the circuit of which were included a galvanic battery and a suitable electroscope, he found that the current circulated freely. Similar experiments were made in the Weser; then with two wells, 21 feet deep, and 200 feet apart; and, lastly, across a meadow 3000 feet wide. Whenever the ground was dry it was only necessary to wet it in order to feel a shock sent through an insulated wire from the distant battery. Erman, of Berlin, in 1803, and Sömmerring, of Munich, in 1811, performed like experiments, the one in the water of the Havel, and the other along the river Isar.\*

All these are very early and very striking instances of the use of the earth circuit for dynamic electricity; but the most surprising and apposite instance of all has yet to be mentioned, in which the use of the earth

\* Gilbert's *Ann. der Physik*, vol. xiv. pp. 26 and 385; and Hamel's *Historical Account*, &c., p. 17 of Cooke's reprint. Fechner, of Leipsic, after referring to Basse's and Erman's experiments in his *Lehrbuch des Galvanismus* (p. 268), goes on to explain the conductivity of the earth in accordance with Ohm's laws. As he immediately after alludes to the proposals for electric telegraphs, he has sometimes been credited with the knowledge of the fact that the earth could be used to complete the circuit in such cases. This, however, is not the fact, as we learn from a letter which Fechner addressed to Professor Zetzsche on the 19th February, 1872 (*Zetzsche's Geschichte der Elektrischen Telegraphie*, p. 19).

is suggested precisely as we employ it to-day. In a letter signed "Corpusculum," and dated December 8, 1837, in the *Mechanics' Magazine*,\* we read:—

"It seems many persons have formed designs for telegraphs. I, too, formed mine, and prepared a specification of it five years ago, and that included the plan of making one wire only serve for the returning wire for all the rest, as in Alexander's telegraph; *but even that might, I think, be dispensed with where a good discharging train, as gas, or water, pipes, at each end of the telegraph could be obtained.*"

In July 1838, or seven months after the publication of "Corpusculum's" letter, Steinheil made his *accidental* discovery in a way which we find thus related by De la Rive:†—

"Gauss having suggested the idea that the two rails of a railway might be employed as conductors for the electric telegraph, Steinheil, in 1838, tried the experiment on the railroad from Nüremburg to Fürth, but was unable to obtain an insulation of the rails sufficiently perfect for the current to reach from one station to the other. The great conductivity, with which he remarked that the earth was endowed, caused him to presume that it would be possible to employ it instead of the return wire. The trials that he made in order to prove the accuracy of this conclusion were followed

\* For 1837, p. 219. The full text of this interesting letter will be found at p. 477, *infra*.

† *Treatise on Electricity*, London, 1853-58, vol. iii. p. 351.

by complete success; and he then introduced into electric telegraphy one of its greatest improvements."

In Steinheil's own account of this discovery, he begins by pointing out that Ampère required for his telegraphic proposal more than sixty line wires; that Sömmerring reduced the number to thirty or so; Cooke and Wheatstone to five; and Schilling, Gauss, and Morse to "one single wire running to the distant station and back."

He then goes on to say:—"One might imagine that this part of the arrangement could not be further simplified; such, however, is by no means the case. I have found that even the half of this length of wire may be dispensed with, and that, with certain precautions, its place is supplied by the ground itself. We know in theory that the conducting powers of the ground and of water are very small compared with that of the metals, especially copper. It seems, however, to have been previously overlooked that we have it within our reach to make a perfectly good conductor out of water, or any other of the so-called semi-conductors.

"All that is required is that the surface that its section presents should be as much greater than that of the metal as its conducting power is less. In that case the resistance offered by the semi-conductor will equal that of the perfect conductor; and as we can make conductors of the ground of any size we please, simply by adapting to the ends of the wires plates

presenting a sufficient surface of contact, it is evident that we can diminish the resistance offered by the ground, or water, to any extent we like. We can indeed so reduce this resistance as to make it quite insensible when compared to that offered by a metallic wire, so that not only is half the wire circuit spared, but even the resistance that such a circuit would present is diminished by one half.

“The inquiry into the laws of dispersion according to which the ground, whose mass is unlimited, is acted upon by the passage of the galvanic current, appeared to be a subject replete with interest. The galvanic excitation cannot be confined to the portions of earth situated between the two ends of the wire; on the contrary, it cannot but extend itself indefinitely, and it, therefore, only depends on the law that obtains in this excitation of the ground, and the distance of the exciting terminations of the wire, *whether it is necessary or not to have any metallic communication at all for carrying on telegraphic intercourse.*

“An apparatus can, it is true, be constructed in which the inductor, having no other metallic connection with the multiplier than the excitation transmitted through the ground, shall produce galvanic currents in that multiplier sufficient to cause a visible deflection of the bar. This is a hitherto unobserved fact, and may be classed amongst the most extraordinary phenomena that science has revealed to us. It only holds good, however, for small distances ;

and it must be left to the future to decide whether we shall ever succeed in telegraphing at great distances without any metallic communication at all. My experiments prove that such a thing is possible up to distances of 50 feet. For greater distances we can only conceive it feasible by augmenting the power of the galvanic induction, or by appropriate multipliers constructed for the purpose, or, in conclusion, by increasing the surface of contact presented by the ends of the multipliers. At all events the phenomenon merits our best attention, and its influence will not perhaps be altogether overlooked in the theoretic views we may form with regard to galvanism itself." \*

\* Sturgeon's *Annals of Electricity*, vol. iii. pp. 450-2. Dr. O'Shaughnessy (afterwards Sir William O'S. Brooke), the organiser of the East Indian telegraphs, claims to have independently discovered the earth circuit, and points for evidence to his paper in the *Journal of the Asiatic Society of Bengal*, for September 1839, pp. 714-31. See his *Electric Telegraph in British India*, London, 1853, p. 21.

## CHAPTER XIII.

EDWARD DAVY AND THE ELECTRIC TELEGRAPH,  
1836-1839.

“ It seldom happens that the author of a great discovery, after failing to attract attention to his application of science, lives to see his own invention universally adopted. Mr. R—— appears to be the least pushing of original inventors, and it is just that in his later years he should have the satisfaction of knowing that he is appreciated by his countrymen.”—*Saturday Review*, November 17, 1866.

FEW of our readers have heard of the name of Edward Davy in connection with the history of the telegraph, and for the sufficient reason that, beyond a few very short and very imperfect accounts\* of a needle telegraph which he exhibited in London in 1837-38, and extracts, more or less copious, from the specification of his electro-chemical recording telegraph, patented in July 1838, nothing has been published regarding him and his early labours. Yet it is certain that, in those days, he had a clearer grasp of the requirements and capabilities of an electric telegraph than, probably, Cooke and Wheatstone themselves; and had he been taken up by capitalists, and his ideas licked into shape by actual practice, as they and theirs were, he would have successfully competed with them for a share of the profits and

\* *Mechanics' Magazine*, for January 20, and February 3, and 17, 1838; on which are based the very meagre and, of course, incorrect descriptions in all books on the telegraph. Also the *Penny Mechanic*, for February 10, 1838.



honours, which have so largely accrued to them as the practical introducers of the electric telegraph.

This, at all events, is the conclusion that we have come to, after the perusal of a number of most interesting MS. documents, which have been obligingly placed in our hands by Dr. Henry Davy, of Exeter, Edward Davy's nephew; and it is a conclusion which, we believe, our readers will cordially indorse when they have read the extracts from them, which we are now about to give.\* We feel a peculiar satisfaction at being thus the means of re-introducing to his countrymen one who deserves a most honourable recognition. Mr. Davy, we are glad to say, is alive and well, and, though now 78 years of age, is still following his profession, as a surgeon, in a far-off colony, whither, for reasons which need not concern us, he emigrated in 1839.

The idea of an electric telegraph first occurred to him about 1836, when he sketched out a plan to be worked by static, or frictional, electricity. We give it almost in the author's own words :—

*“ Outline of a New Plan of Telegraphic Communication, by which Intelligence may be Conveyed, with Precision, to Unlimited Distances, in an Instant of Time, Independent of Fog or Darkness.*

“ The agent is electricity, which is well known to pass through a conducting medium with the rapidity

\* At our suggestion Dr. Davy has presented all these valuable MSS. to the Society of Telegraph-Engineers and Electricians for deposition in the library, where they may now be consulted.

of lightning. The only difficulty is in the mode of applying it to the end proposed. Our method is as follows:—

“Let us suppose a number of copper wires, each covered with silk, and varnished, to be laid underground, side by side, from London to Liverpool. For greater protection, they may be enclosed in an iron pipe. If there be a small brass ball at each end of each wire, an electric spark applied to the ball at the London end of any of them might be drawn at the same instant from the corresponding ball at the Liverpool end.

“If there be twenty-four such wires, there will be one for each letter in the alphabet; but six wires would be more than sufficient in practice, owing to the numerous changes that might be made upon them by combination. We will, however, suppose that there are twenty-four, for the sake of illustration, and that the intelligence is to be sent from London to Liverpool.

“The questions, then, are—

“1st. How the wires are to receive the signals in London.

“2nd. How they are to deliver them in Liverpool.

“A single letter may be indicated at a time, each letter being taken down by the attendant as it arrives, so as to form words and sentences; but it will be easy to see that, from the infinite changes upon a number of letters, a great number of ordinary communications [whole sentences] may be conveyed by a single pre-

viously concerted signal [consisting of one, or more letters in a group].

“Let *a, b*, Fig. 23, represent one of the wires—*a*, the London end, and *b*, the Liverpool end. At *a*, is fixed a small metallic cup of mercury; *c, d, e*, is a bar of metal moving on a hinge at *d*, so that when the end *c*, is elevated, *e*, will dip into the mercury; *f*, is a chain, or wire, communicating with the prime conductor of an electrical machine, or with a powerful electro-

FIG. 23.  
(Drawn from original Manuscript.)

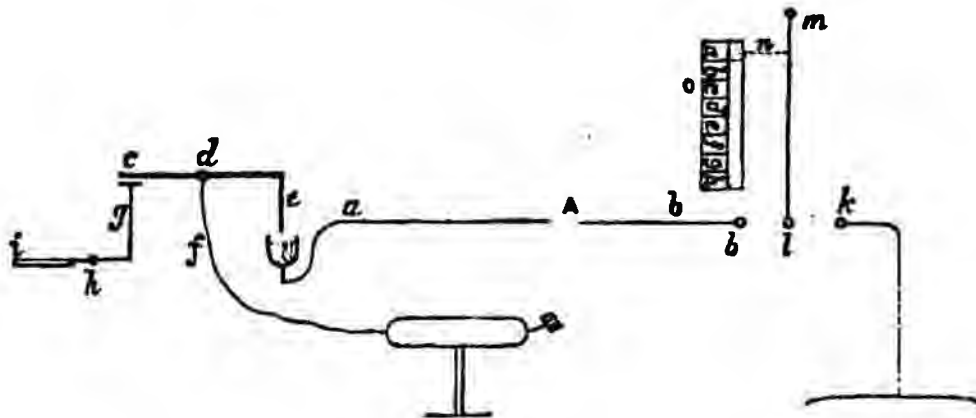

phorus. The hinge, or pivot, *d*, may be continuous metal, and common to all the bars belonging to all the wires. *g, h, i*, is made of glass, or partly of sealing wax, and turns on a hinge, or pivot, *h*, something like the key of a pianoforte. The pressure of the finger at *i*, will then raise *g*, and *c*, and depress *e*, which, by dipping into the mercury, will communicate the electric spark from *f*, to the wire *a, b*. This wire may stand for the letter *A*; and each of the others will

be connected to a similar key apparatus, the same source of electricity sufficing for all.

“At the Liverpool end is a small brass ball *b*; and *k*, is another, communicating by means of a metallic conductor with the earth; *l*, is a light [pith] ball suspended from *m*, by a rigid rod. When the electricity arrives at *b*, *l*, is attracted, and immediately after repelled to *k*, where it discharges itself, afterwards resuming its normal position midway between *b*, and *k*. *o*, contains the letters ranged in a row, and each letter is connected to the rod of the corresponding electrometer by a stiff hair, as shown in the dotted line, *n*. It is evident, then, that, at every movement of the rod towards *k*, the letter will be drawn from its place of concealment, and exposed to view in the open space above.”

This, as Davy himself distinctly says, was not the plan that he would recommend in practice, and was described merely as an aid to a clearer perception of the principles involved. Accordingly, we find him, very soon afterwards, drawing up a proposal for a telegraph, based on the electro-magnetic properties of the voltaic current.

This was to consist of as many line wires as there were letters of the alphabet. Twenty, he says, would have sufficed, or a still fewer number would do, by having recourse to the various combinations of which they would be, obviously, susceptible. Besides the letter wires, there was to be one for the alarum,

and another for the return circuit, which was to be common to all. As to the *form* of the wires, Davy says :—“ Since the electricity is believed to move on the surface, and not in the substance, of a conductor, I conceive that where there is a long distance to travel, instead of wires, it will be preferable to use broad ribbons, such as would be obtained by passing a thick copper wire between the rollers of a flattening mill.”\*

Each ribbon, for its perfect insulation and protection, was to be varnished with shellac, then covered with silk, or woollen, and laid in a slight frame of wood, well dried and varnished ; or each ribbon might be bound from end to end with listing, saturated with melted pitch, or surrounded with caoutchouc, or with cloth saturated with this substance. All the ribbons, in whatever way insulated, were to be laid together underground in air-tight and water-tight pipes of iron, or earthenware.

The best source of electricity Davy considered would be, either one of Daniell's constant-current cells, then just discovered, or, perhaps, a magneto-electric machine as constructed by Newman or Clarke. The electricity so obtained was to be set in motion in the wires by a set of keys, resembling those of a pianoforte, and connected to their respective wires in the way that we have just described. On pressing a key, its wire would dip into a cup of mercury con-

\* It is but fair to mention that this and one or two others are the only cases of false reasoning to be found in all Davy's MSS.

ected with the source of, say, positive electricity, and thus a communication could be readily established, which would be instantly broken when the finger ceased to press on the key. The return wire was to be permanently connected to the source of negative electricity.

At the receiving end the signals might be indicated in various ways, in the adoption of one or other of which much, he says, would depend on the actual amount of electricity that would be available. Davy gave the preference to the following method:—Each line wire was to terminate in another of smaller size, formed into a rectangular coil of from five to two hundred turns, according to circumstances. All the coils were to be ranged in a row in the magnetic meridian, and in each was to be suspended a delicate magnetic needle. The whole was then to be covered by a board, the straight edge of which just concealed the needles in their positions of rest, but, on any of them being deflected, allowed one end to project, and so expose the letter marked upon it. The feeblest current, says Davy, would usually suffice to cause this deflection; but if, *from the great distance that the electricity had to travel, it became too feeble, its effect on the needles could be increased by multiplying the convolutions of the coils.*

“The quantity of electricity,” he goes on to say, “requisite to deflect a magnetic needle is so inconsiderable, that if the current of a moderately-sized

pair of plates were sent into one end of a wire, and only one-hundredth part of it came out at the other end, it would still be sufficient. It is for this reason that I prefer the method just described, of indicating the signals, to others which occur to me, and which, as they may answer under certain circumstances, I will briefly describe :—

“ 1. A coil of wire from each conductor may be wound round a vertical glass tube, a light needle, or slip, of iron inserted in this tube will be lifted up while the electricity is passing through the coil ; a letter fixed to the iron by a bristle will then appear above the lip of the tube and be the signal.\* The only objection to this plan, in other respects the neatest and simplest, is, that the force of the current after passing a long distance may not be sufficient to raise the iron.

“ 2. On the same principle, a piece of soft iron may be surrounded by a helix of copper wire, so as to form a temporary magnet, which will attract and relinquish a small piece of iron carrying the signal letter, at every make and break of the current.

“ 3. Instead of steel needles, coils of copper wire may be deflected in the neighbourhood of fixed magnets ; thus, *a b*, Fig. 24, are mercury cups, into which dip the line wires *c, d*, and the ends of the coil *e*, which are provided with steel points, and rest on agate surfaces, so that the coil can revolve with perfect freedom ; a

\* Here we have the germ of the axial magnet used in Royal House's telegraph.

slender spring, *f*, keeps the coil in its normal position of rest. During the passage of electricity in the coil it [the coil] will be subject to the influence of *g*, and be deflected." \*

FIG. 24. (Drawn from original manuscript.)

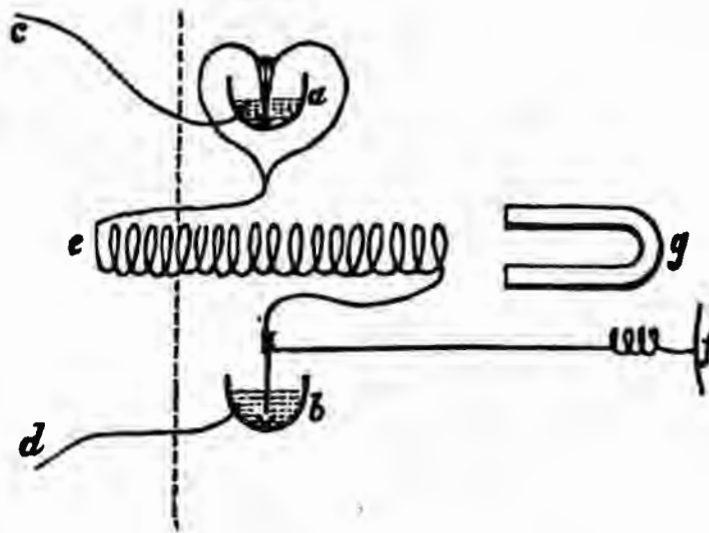

The alarum was to consist of a coil and needle, similar to those used for the letters, only that the needle was to carry a little fulminating silver card, which, on the passage of a current through the coil, was brought into the flame of a small lamp, and exploded.

Davy concludes the document from which we have been quoting with a few words on the general question of conservancy, in which he says that the best situation for the lines would be along railways, where a

\* Here we have the germ of the Brown and Allan relay. Davy says this plan is suggested on the possibility of steel magnets being influenced by the wrong wires, which might happen when all are close together in one parallel row.



number of men are constantly watching, and would prevent damage.

At short intervals, as every half mile, more or less, he would have a contrivance (not described), for ascertaining in what precise spot a fault existed, in case of any derangement of the wires. For this purpose the continuity of the copper was to be interrupted, and the two ends made to communicate by means of a cup of mercury. The places where these interruptions occurred were to be under lock and key in the possession of the surveyor.

According to the "Statement" which we find amongst Davy's MSS., giving the order in which his discoveries were made, he had not long finished the preceding paper when he saw how the number of wires might be reduced one half, by employing reverse currents to produce right and left deflections of each needle, each of which deflections could represent a letter. Other and very important improvements followed in quick succession, until, at the commencement of 1837, his ideas had not only assumed a really practical form, but his apparatus was so far complete that he was able to submit it to the test of actual experiment. For this purpose he obtained permission of the Commissioners of Woods and Forests to lay down a mile of copper wire, around the inner circle of the Regent's Park, through which, with the help of his friend, Mr. Grave, he performed many successful experiments.

Soon after this, in March 1837, Davy appears to have been alarmed by the rumours which got abroad of Professor Wheatstone being engaged on an electric telegraph, and, in order to secure for himself a priority, he hastened to lodge a *caveat*, and, at the same time, deposited with Mr. Aikin, the Secretary of the Society of Arts, a sealed description of his invention, in its then state.

Davy now added the relay, or, as he called it, the "Electrical Renewer," which was the only thing wanted to make his apparatus complete and practicable, and the idea of which, it appears, occurred to him after a conversation on the subject of a telegraph, with a Mr. Bush of the Great Western Railway.\*

\* Writing to the author, on June 11, 1883, Mr. Davy says on this subject:—"I procured access to the private part of the Regent's Park, and laid down a mile of copper wire on the ground, without any insulation. I, of course, found that the magnetic power was so much reduced by the length of the wire that there might be difficulty at great distances in working the contrivance I had in view for marking down signals. The power was, however, sufficient to deflect a not very delicate galvanometer needle.

"It then occurred to me that the smallest motion (to a hair's breadth) of the needle would suffice to bring into contact two metallic surfaces so as to establish a new circuit, dependent on a local battery; and so on *ad infinitum*.

"In Cooke and Wheatstone's first patent there is a proposal to produce a powerful alarm, by striking a bell through the intervention of a local battery; but *not a word about any renewer, or relay, as applicable to general electric telegraphy*.

"The relay was equally new to Mr. Morse, and was subsidiary, if not essential, to his admirable method of dots and dashes. On the occasion of my opposing his application for an English patent in 1838, the Solicitor-General told me that he (Morse) had then no idea of the relay.

"The principle of the relay rendered demonstrably practicable the

In May 1837, Cooke and Wheatstone applied for their first patent, and to this Davy entered an opposition, lodging with the Solicitor-General, of the time, a full description of his own apparatus. A copy of this important document\* is now before us, and as, when taken in connection with what we have already written, it shows, in a very clear way, Davy's position in May 1837, we shall copy it *in extenso*, merely omitting a few preparatory remarks on the general principles of an electric telegraph, which, though necessary, because little understood, in Davy's time, need not now be repeated. We have also made a few verbal alterations here and there, which, while they in no way affect the sense, will, we hope, render the writer's meaning more clear. A comparison of this paper with Cooke and Wheatstone's first specification will be a curious study, and, all things considered, will certainly not be to Davy's disadvantage.

---

system of overland communication by electricity over unlimited distances, and, doubtless, had the effect of removing hesitation from the minds of those who might otherwise have thought the success of electric telegraphy problematical."

There can be no doubt that to Davy belongs the credit of the discovery of the relay system. The first Electric Telegraph Company bought up his patent, chiefly for the reason that it covered the use of the relay. See p. 366 *infra*.

\* "This document is either a copy, or the identical one, left with the Solicitor-General. It may not originally have been prepared for that purpose, but, being ready and suitable, was so used. Perhaps it was returned to me and so found its place amongst my other papers."—Extract from Mr. Davy's letter of October 10, 1883, to the author.

“OUTLINE DESCRIPTION OF MY IMPROVED ELECTRICAL TELEGRAPH.

“The parts of the telegraph may be divided into three, *viz.*:—

- 1st. Signal and alarum arrangements.
- 2nd. Originating mechanism.
- 3rd. Conducting and continuing arrangements.

“1. *Signals and Alarums.*

“These are effected by a number of galvanometer needles, and conducting wires, each of which terminates in a double coil, which acts upon two needles. The form of the coil is that of the figure 8 (only the loops are made rectangular), and in each loop a magnetic needle is suspended. The whole is so arranged that all the needles point north and south. By means of pins, or stops, each needle is prevented from having its signal pole deflected except in one direction. It is then evident that if the electric current be passing in one direction the upper needle only, and, if in the other direction, the lower needle only, will be deflected. This method greatly obviates the objectionable vibration of such needles when suspended in the ordinary way, which vibration is a great impediment to transmitting the signals with sufficient rapidity of succession.

“ The needles are as follows, being altogether twelve in number :—

4 pairs of letter needles,  
1 pair of colour needles,  
1 pair of alarum needles.

“ *Letter and Colour Needles.*—The deflectable extremity of each letter needle bears three letters, A, B, C, and so on, each differently coloured, say, A red, B black, C white. Which of the three letters is intended for the signal is decided by simultaneously observing the colour needles, one of which has its deflectable extremity red, and the other black. If neither of the colour needles move, the white letter is the intended signal. By this plan the number of needles, and, consequently, of conducting wires, is reduced to the minimum consistent with convenience. One of the colour needles acting alone may, of course, convey some arbitrary meaning, according to the exigencies of the establishment.

“ *Alarum Needles.*—Of these only one is essential, so that the other is available for any other purpose required. The alarum needle is shaped so that a suitable piece of card, loaded with fulminating silver, may readily be slipped on to its extremity, which, when the needle turns, is carried round into the heat of a lamp constantly burning beside it. The card is to be renewed as often as it has been exploded, and a number are always at hand for the purpose. This

alarum serves to call the attention of the person who is to watch the signals, and the same principle is evidently applicable to other purposes independent of the telegraph.

“There are other modes of producing different kinds of alarums, which, by the application of the principle on which the electric currents are continued [*i. e.*, relayed], can be accomplished without difficulty.

“ 2. *Originating Mechanism.*

“ This consists of—2 galvanic pairs of plates,  
2 reversers,  
4 pairs of communicating keys,  
1 pair of colour keys,  
1 pair of alarum keys.

“ One pair of plates and one reverser belong to the keys of the colour needles exclusively, the other pair of plates and reverser being common to all the other keys. As the action of the two reversers is the same, they may both be included under one description.

“ *The Reverser.*—The zinc and copper plates are, each, in communication with separate cups of mercury, which we may call, severally, the zinc and copper cups. There are two wires, one of which we may call the common communicator, and the other the return wire, each terminating in a double, or forked, extremity. To a wooden beam, capable of a certain degree of revolution on its axis, both of these forked pieces are

fixed, so that if, in one position, the common communicator is in connection with the zinc cup, and the return wire with the copper cup, a partial revolution of the beam reverses the connections, making the wire from the common communicator now dip into the copper cup, and the return wire into the zinc cup. The reverser is actuated by every alternate communicating key.

“*The Communicating Keys.*—These somewhat resemble the keys of a pianoforte, and there is a pair for each wire. Pressure upon the first of each pair causes the point of the line wire connected with it to dip into a cup of mercury continuous with the common communicator, which enables us to establish, or cut off, in the most convenient way, the connection between the galvanic pair at one end, and the signal needles at the other. The second key of each pair, when pressed, turns the reverser before effecting the connection with the line wire, and, consequently, causes a reversed current to flow into the line.

“The colour and alarum keys are operated in the same way.

### “3. *Conducting and Continuing Arrangements.*

“To command the signals not more than eight conducting wires will be required (probably less). All the letter and the alarum conductors, having, severally, formed their double coils, terminate in a cup of mercury from which a single conducting wire, called the

return wire, reaches back to the originating station, where it is in connection with either the copper, or the zinc cup, according as the reverser may be set. The colour needles have a separate return wire,\* as well as a separate reverser and pair of plates.

“The best mode of laying the conducting wires remains to be determined by experience on a large scale, and the localities through which they may have to be brought. Either they may be somewhat flattened between rollers, and bound together with interposed pieces of cloth, soaked in pitch or rosin, &c., the whole being enveloped with canvas tarred, or impregnated with melted caoutchouc and linseed oil, or the like; or they may be secured in a tube (jointed laterally) of iron or earthenware. In the former case they would admit of *being suspended in the air, from post to post, protected by lightning conductors*, while in the latter they would be laid along, or underground; or they may be separately coiled round with cotton, and bound together, each being of a different colour for guidance in case of repairs.

“As it may be more than doubted that an electric current in a circuit of great length, as between London and Dover, or London and Liverpool, would retain sufficient magnetic power to effect the signals

\* Davy soon suppressed this, as he found that one return wire would suffice for *all*. He thus reduced the number of line wires to seven, *vis.*, four for letters, one for the alarm, one for the colour needles, and one return wire.



after travelling so far, it may be made to renew itself at given intervals, by the following self-acting contrivance :—

*“The Electrical Renewer.*—The principle of this contrivance is that, the total distance being divided into a number of shorter ones, there be a separate galvanic circuit for each, and that, at the termination of each length of wire, its current be made to produce a motion, which establishes a communication between a fresh source of electricity and the wire which extends through the next succeeding distance. For instance, the first portion of wire terminates in a rectangular figure of 8 coil, fixed horizontally, so as to act upon needles, so suspended as to be capable only of vertical motion. Each needle is rendered incapable of motion except in one direction, so that one, or the other, will be deflected according to the direction in which the current is passing. At the end of each needle is fixed a cross piece of copper wire, whose ends are turned downwards. One of these ends is constantly immersed in a cup of mercury, which is connected with one of the plates of a galvanic pair, while the other end dips into a second cup of mercury every time the needle is deflected by a current in the coil. This second cup is the commencement of the next circuit.

“To complete the circuit, a corresponding but reverse connection must be made with the return wire, so that while the needle of the signal wire establishes a communication with the zinc, that of the return wire

establishes simultaneously a communication with the copper, and *vice versa*.

“By this contrivance it is clear that there can be no physical limit to the distance to which electric currents may be carried; and, therefore, the expense of long distances will cease to be in an increased ratio to that of short ones.\*

“*Additional Observations.*

“(1). The coils herein described may be either simple, or multiplied, as the case may require. It will probably be better that they should be multiplied, than that the needles should be too delicately suspended.

“(2). For stopping more effectually the vibration of the needles immediately on their relapse, on the cessation of the current, the following plan is proposed:—A portion of the wire is coiled round a small piece of soft iron, which is rendered magnetic during the passage of the electricity, its polarity varying with the direction of the current. This is so arranged that the end of the needle bears against it, and is held by it, when no current of electricity is passing, or when it is passing in one particular direction, and that, when passing in the other direction, the iron will be so polarised as to repel, instead of attract, the point of the needle.†

\* See note on p. 359 *supra*.

† There is a contrivance like this, and for exactly the same purpose, in Cooke and Wheatstone's first patent of 1837.

“(3). There is a variety of modes in which different kinds of alarums may be made, when once the principle of the Electrical Renewer is applied, as there is then no limit to the power which may be obtained, and it requires little reflection to suggest a multiplicity of methods of making this power produce sound. A piece of soft iron may be rendered alternately magnetic and non-magnetic, so as to withdraw, when required, the peg of an alarum clock, &c., or a needle may be made to carry round a red-hot wire, or match, so as to explode a cannon, &c.

“(4). *Portable Telegraphs*.—Such a contrivance might occasionally be useful in warfare. The conductors should then be made in short lengths, each conductor differently coloured for facility of distinction.

“(5). *Marine Telegraphs*.—Communications may be effected through, or under, the water by enclosing the conductors in ropes well coated, or soaked, in an insulating and protecting varnish, as melted caoutchouc, &c. The ropes could then be sunk to a certain depth by weights, and supported by small floats, or buoys. In connection with the rope we may have an air-tight and water-tight electrical renewing apparatus [*i. e.*, Relay] at each requisite interval.\* On this subject further experiments are necessary.

“(6). Land telegraphs may, of course, be made to indicate similar signals and produce similar alarums at numerous places at the same time.

\* As in Van Choate's patent No. 156 of January 19, 1865.

“(7). Estimated expense of particular lines of communication at 70*l.* per mile, which includes two sets of wires for communicating in each direction: \*—

	From	Miles.	£
London to Dover	.. .. .	71	5,000
„ Brighton	.. .. .	51	3,500
„ Bristol	.. .. .	119	8,500
„ Portsmouth	.. .. .	72	5,000
„ Birmingham	.. .. .	109	7,770
„ Liverpool	.. .. .	206	14,000
„ York	.. .. .	199	14,000
„ Newcastle	.. .. .	273	19,000
„ Edinburgh	.. .. .	367	26,000
„ Glasgow	.. .. .	400	28,000
„ Exeter	.. .. .	164	11,500
Liverpool to Manchester	.. .. .	30	2,200
			£144,000

“(8). Annual expense of each station, comprising salary of four or five clerks, attendants, rent, and workman to feed the batteries and keep the apparatus in order, 600*l.*

Outlay from London through Birmingham to Liverpool	14,000 <i>l.</i> , or say 20,000 <i>l.</i> , of which	£
the interest at 5 per cent. per annum	.. ..	1,000
Expense of three stations, one in each town, at 600 <i>l.</i> each	.. .. .	1,800
Contingencies	.. .. .	200
		£3,000

\* It is not that Davy did not know how to make his apparatus reciprocating, so that one set of wires should suffice for to and fro correspondence, but because, as he explains in other places, he thought that when once the telegraph was established there would be more traffic than one set of wires could carry; and he, therefore, recommends here, as elsewhere, the laying down at once of an *up* and *down* set of wires, for exactly the same reasons that we have *up* and *down* lines of railway.

which, including Sundays, is about 10*l.* per day ; and this, divided by 3, gives 3*l.* 6*s.* 8*d.* as the sum necessary to be received, on an average per day, at each station, in order to pay expenses and return an interest of 5 per cent. for the outlay.

“(9). *Capabilities.*—The telegraph constructed on the plan herein described is capable of transmitting about fifty letters in two and a half minutes, but, by an improvement devised subsequently to writing the early part of this description, they may be sent several times as rapidly. In fact, the only limit now appears to be the quickness with which the eye can catch the letter, and the hand note it down.”

During the summer and autumn of 1837, as stated in the last paragraph, Davy effected some important changes in the mode of making the signals. In the plan just described the needles were made to turn horizontally, and the eye was obliged to attend to two movements, at the same time, in order to distinguish by the colour needle, which of the three letters was meant. The oscillation of the needles in settling down to their positions of rest caused a waste of time, and was otherwise a bar to rapid signalling. By the following plan both these disadvantages were obviated without introducing fresh ones:—

The needles were all suspended, somewhat like balance beams, so as to turn vertically, instead of horizontally, and they were made long, so that their

ends might describe large arcs, although the movement at the centre might be small. The letter ends were weighted so as, under ordinary circumstances, to dip under cover, but, on the passage of a current, they were raised, so as to bring the letters opposite an illuminated sight groove.

What used to be the colour needles were now provided with small screens, which could be raised, or depressed, in front of the letter needles, so as to conceal, or expose, them at pleasure. Thus, if the

A

letter needle bearing B were shown, and neither of the

C

distinguishing needles moved, their screens would lay so as to cover A, and C, B, only being visible. If now one screen, say the top one, were deflected it would cover B, and expose A, and, similarly, if the other screen were moved it would expose C, and cover B.

In this arrangement the eye had to watch only one signal, and, as all the letters could be arranged more compactly, the field of view was greatly reduced, and the letters could be easily caught and noted down, without the necessity of even turning the eyes.

The next alteration was in the same direction of simplification and perfection of the signalling apparatus, and was a decided improvement even upon the last. It consisted in making the letters immovable, and covering them by three screens in such a way as to be able to expose any desired letter at will.

Fig. 25 shows the arrangement. 1, 2, 3, 4, were pairs of screens, which, when at rest, covered all the letters, ranged in rows of three behind them, and one, or other, of which, in each pair, could be moved aside, according to the direction of the current in the line wire to which it belonged. The screens 5, 5, and 6, 6, answering to the colour needles of the old plan, but now called *triplicators*, were so arranged as, in their normal position, to cover the top and bottom rows of letters, and, on the passage of a current in their coils, to move inward and cover the centre row.

FIG. 25.

(Drawn from original manuscript.)

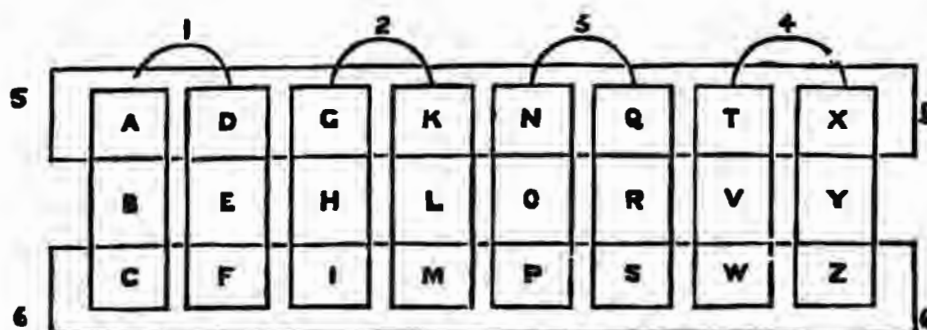

If, now, any one of the letter screens, say that on the extreme left of the figure, were moved aside, only one letter, B, would appear ; because A, and all the letters in the top row, would be covered by the triplicator 5, 5, and C, and its fellows in the bottom row, by the triplicator 6, 6 ; but if one of the triplicators, as 5, 5, had been simultaneously moved, then only the letter A, would appear. Thus, a single movement of a letter screen will expose any letter in the centre row,

and a combined movement of a letter screen and a triplicator will exhibit any letter in the top, or bottom, row according to the triplicator employed.

But, as each wire was to be provided with a separate battery, and as the currents could be sent in one direction, or another, in one, or more, wires at the same time, it is clear that one to four letters could be shown at once, *provided* they were all in the same row, and were not covered by the same pairs of screens. Thus, the word B O Y could be signalled at once, by sending, say, a positive current into the first wire (on the left), exposing B, a positive current into the third wire, exposing O, and a negative current into the fourth wire, exposing Y. Again, the word A N T could be shown at once, by sending a current into the triplicator wire, so as to cause the screen 5, 5, to move down, then a positive current sent into the first, third, and fourth letter wires would uncover the letters A, N, T, respectively. In this way, besides being able to show all the letters of the alphabet singly, about 200 different groups of letters could be displayed at one operation, which, by having certain meanings attached to them, would greatly expedite a correspondence.

The needles by which the screens were actuated were, as before, suspended in the manner of ordinary balance beams with horizontal axes; but these axes were now prolonged, and carried tall upright rods, at the free ends of which the screens were fastened.



Thus, the slightest movement of the axes produced a considerable deviation of the screens, while their extension permitted of the needles (with, of course, their coils) being placed at sufficient distances apart to prevent their mutual disturbance.

In the working model which Davy had constructed for exhibition all the letter-indicating mechanism was enclosed in a mahogany case, which could serve also as a desk for writing down the signals as they appeared. In the front of the case there was an aperture about sixteen inches long, and three or four inches wide, and this, at ordinary times, was so dark that difference of surfaces of the screens could not be detected, which led to the deception that only one screen was used—a deception which the author purposely planned and encouraged, in order that the *modus operandi* of his instrument might not be divined, which would prevent him taking out a patent for it afterwards, as he contemplated doing.\* Behind the screens was a plate of glass, covered with black card-board, out of which spaces, representing the letters of the alphabet, were cut, and behind the glass was a white card-board, on which the light of a lamp was thrown. The result was that, whenever a screen was turned aside, a beautifully white letter appeared to the spectator at the aperture.

Attention, in the first instance, was called by three strokes on a little electric bell, the termination of a

\* This little *ruse* explains the fogginess of all accounts of Davy's telegraph hitherto published. See p. 349 and foot-note.

word was indicated by a single stroke, and the end of the communication by two strokes.

A working model, embodying all the author's improvements to date, was shown about November-December 1837, at the Belgrave Institution, London, and from the great interest which it there excited, Davy resolved upon a more public exhibition; accordingly, he rented a room for one year in Exeter Hall, and there installed his telegraph from December 29, 1837, to November 10, 1838.\*

A writer in the *Mechanics' Magazine*, for February 17, 1838, thus describes the exhibit. It will be observed that, for the reason which we have given above, his language in places lacks clearness, but this is of little consequence, for we, who are now in the secret, can easily follow him:—

#### “Davy's Electrical Telegraph.

“Sir,—The favourable notice of your correspondent, ‘Moderator,’† on the subject of Mr. Davy's electrical telegraph, induced me to visit Exeter Hall, for the purpose of carefully inspecting the invention; and I am enabled to bear testimony to the general accuracy of your correspondent's remarks, and also of the great

\* Davy's MSS., No. 5. See also *Mechanics' Magazine*, for January 20, 1838, and “The Electric Telegraph Company *versus* Nott and others,” Nott's and Grane's affidavits. The room occupied by Davy was that known as No. 5, for which he paid rent at the rate of 35*l.* per annum.

† Correctly, “Moderatus,” in *Mechanics' Magazine*, for February 3, 1838, p. 296.

pleasure I experienced in the investigation of the apparatus. Under these circumstances I beg to offer a few additional remarks, in some measure corrective of those made by 'Moderator.'

"As a preliminary observation, I would suggest to the inventor the necessity of removing to some other part of the building, or, if that cannot be accomplished, of quitting the place altogether, and locating himself in some situation where his light may not, literally, be 'hid under a bushel.' He appears to be surrounded by rooms under repair or alteration, and his delicate apparatus is, consequently, smothered with dust; the room is also small, dark, and altogether of most unpromising appearance.

"In front of the oblong trough, or box, a lamp, described by your correspondent, is placed, and that side of the box next the lamp is of ground glass, through which the light is transmitted for the purpose of illuminating the letters. The oblong box is open at the top, but a plate of glass is interposed between the letters and the spectator, through which the latter reads off the letters as they are successively exposed to his view. At the opposite side of the room a small key-board is placed (similar to that of a pianoforte, but smaller) furnished with twelve keys; eight of these have, each, three letters of the alphabet on their upper surfaces, marked thus, A. D., and so

B. E.

C. F.

on. By depressing these keys in various ways the signals, or letters, are produced at the opposite desk as previously described. How this is effected is not described by the inventor, as he intimated that the construction of certain parts of the apparatus must remain *secret*. By the side of the key-board there is placed a small galvanic battery from which proceeds the wire, 25 yards in length, passing round the walls of the room. Along this wire the shock is passed, and operates upon that part of the apparatus which discloses the letters, or signals.

“ The shock is distributed as follows :—The under side of each signal key is furnished with a small projecting piece of wire, which, on depressing the key, is made to enter a small vessel filled with mercury, placed under the outer end of the row of keys. A shock is instantly communicated along the wire, and a letter, or signal, is as instantly disclosed in the oblong box. By attentively looking at the effect produced, it appeared as if a dark slide were withdrawn, thereby disclosing the illuminated letter. A slight vibration of the (apparent) slide occasionally obscuring the letter indicated a great delicacy of action in this part of the contrivance, and, although not distinctly pointed out by the inventor, is to be accounted for in the following manner :—When the two ends of the wire of the galvanic apparatus are brought together over a compass needle the position of the needle is immediately turned at right angles

to its former one ; and again, if the needle is placed with the north point southward, and the ends of the wire are again brought over it, the needle is again forced round to a position at right angles to its original one [*sic*]. Thus it would appear that the slide, or cover, over the letters is poised similarly to the common needle, and that, by the depression of the key, a shock is given in such a way as to cause a motion from right to left, and *vice versa*, disclosing those letters immediately under the needle so operated upon.

“A gentleman present hazarded a doubt as to the shock being energetic enough for a considerable distance. The inventor replied that he was in possession of means that would enable him to convey intelligence to any distance that may be required. Whether this was to be effected by *coils* of wire at intervals was not stated ; such, however, appears to me a reasonable supposition. The difficulty of *tubing* for the protection of the wire was discussed. I took the liberty of suggesting the employment of a proper-sized *tobacco-pipe tubing*, which was received with satisfaction. It was also stated by a gentleman present that he was in possession of a smaller battery than that at Exeter Hall, and had obtained from it a power equal to *forging* iron plate ; it will, he said, be shortly produced.—Yours respectively [*sic*],

“CHRIS. DAVY.

“ 3, Furnival’s Inn, Feb. 5, 1838.”

## CHAPTER XIV.

EDWARD DAVY AND THE ELECTRIC TELEGRAPH,  
1836-1839 (*continued*).

RETURNING to our examination of the Davy MSS., we find a memorandum of another modification of the screen arrangement, which would require only two line wires (and one return wire), and yet would yield twelve elementary signals. This contrivance, which is fully explained, need not, however, detain us further than to indicate the highly ingenious plan adopted for producing some of the necessary changes of the screens. It consisted in the employment, at certain times, of batteries of *different strengths* (they being of necessity of opposite signs), so as to determine, at those times, a current of positive, or negative, sign in the return wire, and thereby actuate screens which, if the currents had been of *equal strength*, would, of course, be inoperative. This neat and effective arrangement was utilised in another of Davy's instruments, of which we must now say a few words.

The recording telegraph is a very beautiful piece of mechanism—the first of a long line of chemical telegraphs,—and we cannot help thinking that, had it had a fair start in 1838, and been fined down by

practice, as it could have been, and as Cooke and Wheatstone's first inventions were, it would have given to English telegraphy a somewhat different character from that impressed upon it by the rival plans, and chemical telegraphs might now be the rule instead of the exception.

Like all his other inventions in telegraphy, Davy perfected this apparatus before December 1837, or, as he says in his "Statement," before the enrolment of Cooke and Wheatstone's first specification, of the nature of which he was, at the time, in perfect ignorance, "except in so far as it could be gathered from paragraphs in the newspapers, which conveyed really no information."

He wished to take out a patent at once for this instrument, but, owing to legal formalities, and the opposition of Cooke and Wheatstone, the specification was not sealed until July 4, 1838. The opposition was based on the plea that some parts of Davy's mechanism were infringements of their patent of June 12, 1837, but, on a reference to Professor Faraday, who gave it as his opinion that the two inventions were distinct, the Solicitor-General quashed the opposition, and allowed the application to pass.\*

\* Davy's MSS., No. 10, contain some warm passages on this most unfair charge. Writing to the author, on June 11, 1883, Mr. Davy says further:—"On applying for my patent Messrs. Cooke and Wheatstone opposed it, before Sir J. Rolfe, the then Solicitor-General. That gentleman, however, told me that he would at once pass my application if I confined myself to the renewer, as on some other matters he had his doubts. I did not feel disposed to relinquish

The following passages, which we have extracted, by kind permission of Mr. Latimer Clark, from the MSS. correspondence of Messrs. Cooke and Wheatstone, are explanatory of this point :—

“20, Conduit Street, Jan. 20, 1838.

“My dear Sir,—

• • • • •

“Davy has advertised an exhibition of an electric telegraph at Exeter Hall, which is to be opened on Monday next. I am told that he employs six wires, by means of which he obtains upwards of two hundred simple and compound signals, and that he rings a bell. I scarcely think that he can effect either of these things without infringing our patent ; if he has done so, I think some step should be taken. As the point of resemblance in Davy’s instrument is, no doubt, a ‘return wire,’ I do not think that an injunction could be procured to restrain him, without proceeding also against the exhibitors of Mr. Alexander’s.

“The latter case is very clear. Previous to our patent no person had ever proposed otherwise than to employ a complete circuit (*i. e.*, two wires) for each

---

any of my claims, so it was arranged to refer the whole matter for advice to Mr. Faraday, with whom both parties were to communicate. It appears that Messrs. Cooke and Wheatstone were under the impression that I wanted to patent only what had been exhibited at Exeter Hall. I spent two or three hours with Mr. Faraday, and left my papers (rough specification) with him, when he said that he would take a week to consider, and report to the Solicitor-General. He accordingly reported that my inventions were quite original, and entitled to a patent. Probably, some notes of this transaction may be found in the records of the Solicitor-General’s office.”



magnetic needle. The most important original feature in my instrument was that the same wire should be capable of forming different circuits according as it was conjoined with other wires.

“After the patent was sealed, a notice of some of my experiments appeared in the *Scotsman*; and some weeks subsequently there appeared in the same paper an account of what Mr. Alexander intended to do, and, after a long interval, a description of a model which he had produced.

“There is no doubt that in our Scotch patent we must limit ourselves to the application of the permutating principle; but as our English patent was sealed before the slightest publicity was given to Mr. Alexander's intentions, I think no lawyer can doubt our priority [in England].

“If Mr. Davy has taken the return wire because he has seen it in Alexander's instrument, and therefore thinks that we do not claim it, the point will be an easy one to settle; but it will be more difficult if he had an idea of it before the hearing by the Solicitor-General. Think over the matter, and let me know your opinion before any proceedings are commenced.

\* \* \* \* \*

“I remain, my dear Sir,

“Yours very truly,

“C. WHEATSTONE.

“W. F. Cooke, Esq.,

“Compton Street, Brunswick Square.”

In a letter dated March 10, 1838, Wheatstone writes :—

“ Let me know the title of Davy’s patent, and also when it is likely the opposition will be heard, as I wish to make some preparations in time. I have heard that a physician, residing in your neighbourhood, is the party who encourages Davy, and furnishes him with cash.”

On March 24, 1838, he wrote :—

“ My dear Sir,—The Solicitor-General was with me twice yesterday at the College. Davy was extremely anxious to obtain a decision on the plea\* of going out of town immediately. The Solicitor-General, however, has not yet given an answer, and on applying at his office this afternoon I was informed he had left word that he should not decide the question for several days. I shall endeavour to see him again to-morrow, as I know his difficulty, and have another argument to offer him.

\* \* \* \* \*

“ Yours very truly,

“ C. WHEATSTONE.

“ W. F. Cooke, Esq.”

The following account of the construction and *modus operandi* of the apparatus we condense from Davy’s specification, to which we refer our readers for

\* We have seen Mr. Davy’s private letters of this date, and know how true the plea was.

fuller details.\* It contains all the essentials of a complete telegraphic system, and can be procured at the Patent Office for a small sum.

“The drawing, Fig. 26, represents the apparatus employed at the place of making a communication, say London, and that at the place where the communication is received, say Birmingham, or Liverpool. The wires A, B, C, are those which are laid down between those places.†

“The principle on which this apparatus works is this, that there be two, or more, wires which communicate with another wire, and, for distinction sake, we will call the former the signal wires, and the latter the common communicator, for it should be understood that no metallic circuit can be formed between the signal wires of themselves, but only by the aid of the common communicator; and further, whatever be the number of wires employed so having a connection with a common communicating-wire, that there be a suitable electric apparatus, such as a voltaic battery, to each signal wire. The drawing shows the apparatus to consist of two signal wires, A, and B, and a common communicating-wire C; and the

\* See also Vail's *American Electro-Magnetic Telegraph*, Philadelphia, 1845, pp. 187-99, or Shaffner's *Telegraph Manual*, New York, 1859, pp. 255-68.

† Sabine, on p. 50 of his *History and Progress of the Electric Telegraph*, 2nd edit., London, 1869, states erroneously that at least four wires were required. That excellent French journal, *La Lumière Électrique* (April 7, 1883), has recently committed the same mistake, and shows four wires in its illustration, Fig. 33.

drawing further shows the apparatus to have three separate batteries; the object in using the third is to obtain a greater extent of signals than can be obtained by the employment of only two. In this case, the common communicating-wire may have needles and suitable apparatus, and may thus become a means of communicating signals as well as the signal wires.

“D, E, are the pair of finger-keys, which cause electric currents to pass through a circuit, partly made up of the signal wire A, and the common communicating-wire C, and it will be found that the parts are so arranged that depressing the key D, will bring the signal wire A, in metallic communication with the negative pole of the battery No. 1, and at the same time cause the common communicating-wire C, to be in metallic communication with the positive pole of the same battery; consequently, the currents will pass positively through the wire C, and negatively through the wire A. The course of the currents may be reversed by depressing the key E, instead of D.

“The keys H, and I, act on the wires B, and C, and form metallic circuits through which currents from the battery No. 2 may be transmitted in like manner to what has just been described in respect to the wires A, and C, and the battery No. 1, by the keys D, E.

“The wires A, B, C, just before being connected together at the distant station, are each formed into

2 C

two coils, or convolutions, similar to what are employed for galvanometers, in order that the electric current may operate with sufficient power on the needles placed within them as to deflect them in a direction corresponding to that in which the current is passing. M, N, show these coils, or convolutions.

FIG. 26.

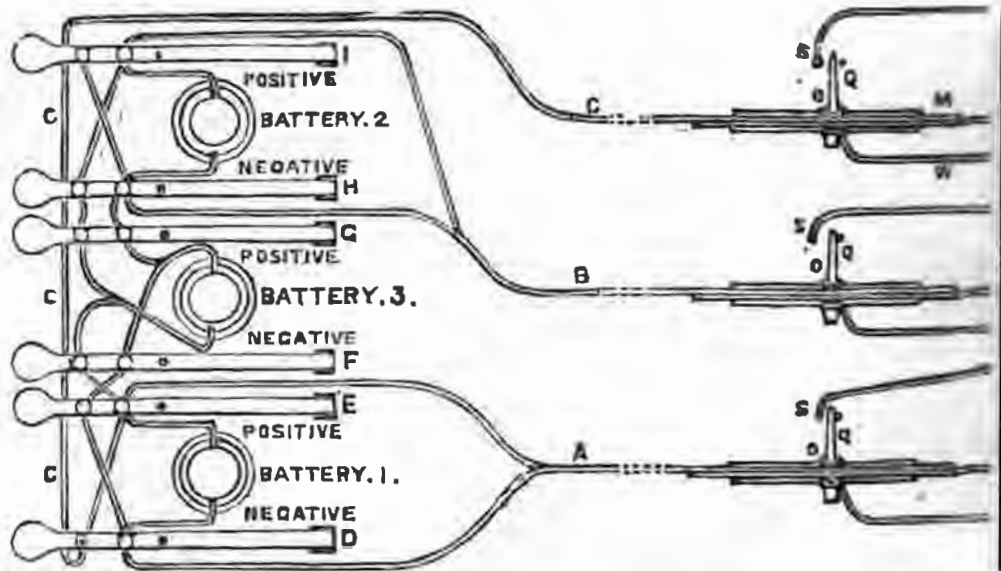

“The needles O, P, are little magnetised plates of steel, moving on points similar to a magnetic needle; and, when at rest, are to be in a line with the coils in which they move. To the upper part of each needle is affixed the upright contacting-piece Q, which at its lower end dips into a little cup of mercury. S, T, are wires against which the upper ends of the contacting-pieces, at times, come in contact in order to form local metallic circuits for the purpose of producing

marks on chemically-prepared fabrics, as hereinafter explained.

“V, is a compound battery from the positive pole of which a wire W, communicates with each and all of the cups containing mercury. Consequently, when any one of the contacting-pieces is caused to touch

FIG. 26.

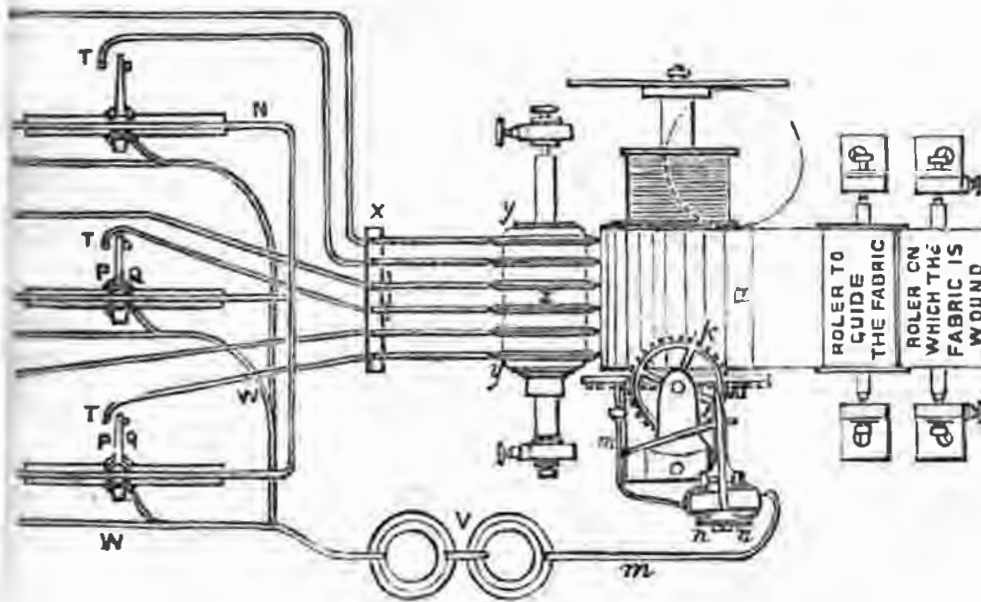

its wire S, or T, as the case may be, there will be a metallic contact with the positive pole of the battery and the said wire S, or T. Thus, supposing a positive current to be passing through the wire A, the contacting-piece Q, of the needle O, of the wire A, would be deflected towards, and would come in contact with, the wire S, and would form a metallic contact between it and the positive pole of the battery V; and, on the other hand, if a negative current pass

through the wire A, the contacting-piece Q, of the needle P, would be brought in contact with the wire T. Thus it will be seen that each line wire has a capability of giving two separate indications, and these may be increased, by compounding, to eight, according to the order in which they are communicated. The number may be still further increased to twelve by applying needles and coils to the wire C, and employing a third battery, marked No. 3, and two extra keys F, G.

“The object of using a third battery is to give greater quantity of electricity to certain currents. Thus, supposing a positive current to be passing through the wire A, and a negative current through the wire B, there would be two currents passing to the wire C, in opposite directions; consequently, the needles on that wire would not be acted on in such manner as to produce a certain and definite indication, *unless* one of the currents so passing be made more powerful than the other. And this may readily be effected by the keys F, G, which can bring the wires A, C, and B, C, in connection with the battery No. 3, in addition to their own.

“The pairs of wires S, T, pass through a block of wood X, which acts as a support. Their ends are forked, and embrace (touch) the metallic rings (of platina)  $\gamma, \gamma$ , affixed to the wooden cylinder Z. These rings press closely against the metallic cylinder  $\alpha$ , which turns in suitable bearings carried by the framing,

as shown in the drawing. This cylinder has a constant tendency to revolve in one direction, communicated to it by a spring or weighted cord as in Fig. 27, but is only permitted to turn a certain distance each time that a signal has been made through the wires.

“It should be stated that there is a metallic contact between the negative pole of the battery V, and the metallic cylinder *a*, by means of the wire *m*, which is coiled round a bent bar, or horse-shoe, of soft iron, in order to produce an electro-magnet *n, n*, and from thence the wire *m*, passes to, and is held in contact with, the end of the cylinder *a*; consequently, whenever any one or more of the contacting-pieces of the needles come in contact with their wires S, or T, a metallic circuit or circuits will be formed; and it will be evident that if properly prepared fabrics, such as calico impregnated with hydriodate of potass and muriate of lime,\* be placed between the metallic

\* “Although I have recommended the use of calico prepared in the manner above stated as the fabric to be used for receiving the marks, I do not confine myself thereto, as other fabrics may be used and the chemical materials employed may be varied, so long as they will be similarly marked by the passage of electric currents. The fabric so employed may be printed with subdivisions, as is shown in the drawing, or it may be used plain, because the marks made, whether a single one or more than one at a time, will be in rows across the fabric; and each row, whatever be the number of marks, will be a signal, and this mode of receiving marks in rows across and lengthwise of the fabric constitutes an important feature in my invention; for although I prefer that the marks should be produced by the chemical action of the electric currents acting on fabrics properly prepared, yet it will be evident that other means of producing a series of marks in rows, crossways and lengthwise of the fabric, may be resorted to, such as pencils or ink



rings  $y, y$ , and the cylinder  $a$ , whichever of these rings are for the time being in circuit will, by pressing against the cylinder  $a$ , pass the current through the prepared fabric, and produce marks thereon. It will only be necessary to assign to each mark so produced a definite cypher referable to a proper key-book, as is well understood in telegraphic communications.

“At the same time that the signal is being thus recorded the armature  $D$ , Fig. 27, of the electro-magnet  $M$ , is attracted, the forked piece  $J$ , in which it terminates, goes up from the pallet  $a$ , of the fly-vane  $G$ , and so allows the cylinder  $K$ , to revolve (carrying with it the prepared fabric) until the pallet  $a$ , coming in contact with the forked piece  $E$ , stops the mechanism. When the hand of the person making the signal is removed from the key or keys, the contacting-pieces resume their vertical positions, thus opening the local circuits. As a consequence, marks cease to be made on the prepared fabric, and at the same time the armature is drawn back by the spring  $S$ ; the fly-vane  $G$ , is thus again liberated, and the cylinder  $K$ ,

---

connected to, or carried by, proper holders acted on by electro-magnets, one pencil, or other marking instrument, to each wire  $S, T$ ; by which means every time a metallic circuit was produced by the aid of any of the wires  $S, T$ , they would cause their electro-magnets to bring the marking instrument in contact with paper, or other suitable fabric, and give marks thereto across such fabric; and as the fabric was moved forward, the next row of marks would be made at a distance from the preceding row, and separated therefrom, the same instrument producing its mark at all times in the same longitudinal row.”—  
Pp. 11, 12 of Davy's specification.

revolves through another space, until once more stopped by the pallet *a*, catching in the arm J. The first movement is for the making of the signals, the second marks the intervals between them.\* The fabric,

FIG. 27.

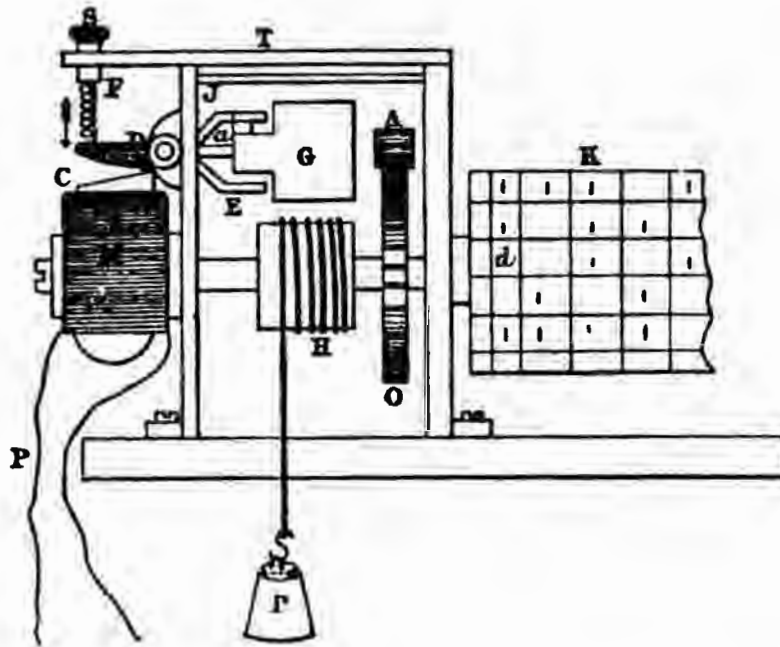

as it is carried forward by the cylinder K, is conducted away over a guide-roller, and drawn forward by a weight, or in any other suitable manner.”

Following the original drafts of this apparatus, which are preserved amongst the Davy MSS., we find

\* As the description of this portion of the instrument is somewhat involved in Davy's specification, we have in the text used our own words, which, with the illustration (borrowed from Schellen), will we hope make the action clear. Vail's *American Electro-Magnetic Telegraph*, pp. 187-99, gives a full and well illustrated account, to which we would refer our readers anxious for further information.

a description of another telegraphic project, which, as our readers will observe, is based on the same electrical principles as the duplex and quadruplex systems of the present day. It is a mode of obtaining one, two, or more signals through a single pair of wires by means of currents of one, two, or more degrees of strength, acting on needles so weighted as only to respond to the currents destined to move them.

For the signal-indicating part of this plan, Davy proposed to employ a new form of galvanometer, which he called an "electro-magnetometer," and which he had designed, in the first place, "for measuring with greater precision than heretofore the exact quantity of electricity passing in any given circuit." This instrument is figured and described in his patent of July 4, 1838, pp. 16, 17.

Foreseeing that to operate a telegraph of this kind it would be necessary to regulate, and keep regulated, the currents with great accuracy, Davy devised, for this purpose, a "self-regulating galvanic battery." "The principle of the contrivance," to quote his own words, "is that as soon as the magnetic energy of its electric current rises above, or falls below, a certain required standard, one of the metals of the galvanic pair is, by the agency of this magnetic energy, either raised out of, or further depressed into, the acid, or exciting liquid, in the cell; so as to become, thereby, less, or more, exposed to the action

of the liquid; the extent of its exposure regulating the quantity of electricity generated.

“To effect this intention, there are two coils in the conducting wire proceeding from the battery, in which are two of my electro-magnetometer needles. Of these needles the dipping end of one is a certain degree heavier than that of the other, and the intention is that the electric current should remain within the limits of the two, so as just to act upon the lighter, but not on the heavier.

FIG. 28. (Drawn from original manuscript.)

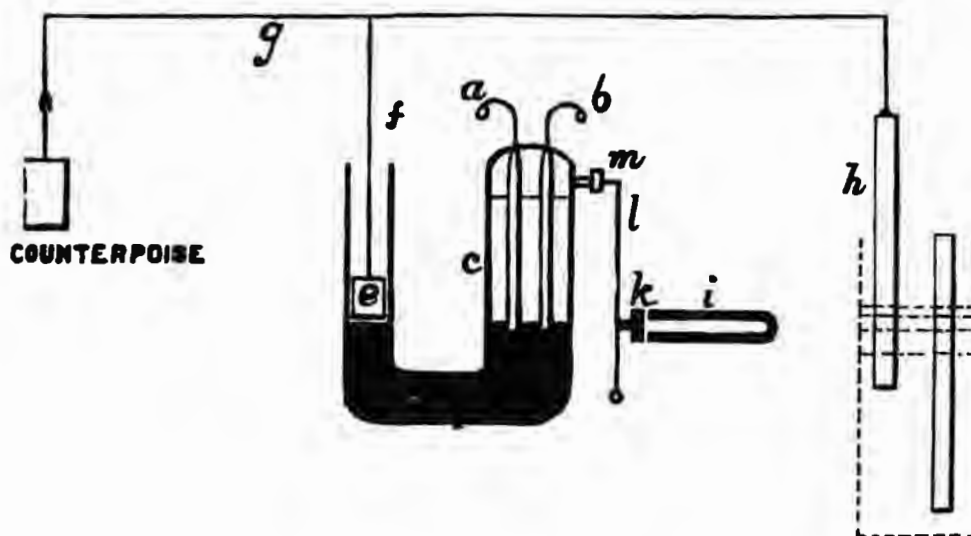

“Now, if the current be too powerful the heavier needle, by dipping, will cause a communication between a fresh, or distinct, source of electricity and the two wires *a*, and *b*, Fig. 28, attached to platina plates in dilute sulphuric acid contained in the airtight tube, *c*. Then, by the decomposition of the water, gases will be evolved, and depress the liquid

at *c*, and also the mercury below it, *d*, so as to elevate the piston, *e*, and its rod, *f*, whereby the lever, *g*, is also elevated, and lifts the metallic plate, *h*, belonging to the galvanic battery, so as to diminish the energy of the said battery to the required degree.

“If, on the other hand, the electric current be too feeble, then the lighter needle will fall and open a communication with another distinct source of electricity through the coil of wire which surrounds the electro-magnet, *i*, whereby it is rendered temporarily magnetic and attracts the armature, *k*, which, through the lever, *l*, removes a caoutchouc (or other suitable) stopper from the minute aperture at *m*, so as to allow the gas in the tube, *c*, to escape until the metallic plate, *h*, has again sunk sufficiently into the liquid in the battery cell to generate the required, or standard, quantity of electricity, such standard being allowed to vary between these minute differences only.

“Having thus obtained the element of a uniform battery, the quantity of electricity to be transmitted through the circuit may be regulated, either by the number of such batteries uniting their currents, or else the current from one battery may be divided; the mode of so dividing it is the remaining consideration.

“The electric current may be made to travel through pieces of platina, or other wire, of different diameters, and of given lengths, so that the thicker the wire, the greater will be the quantity of electricity to pass. The

exact dimensions of these to be regulated by actual experiment,\* and, in order to prevent their ignition and combustion, they may be arranged under water, or, should water be objectionable, under some non-conducting, and non-electro-decomposable liquid, such as sulphuret of carbon, or naphtha, or whatever other may be found advisable."

From amongst Davy's miscellaneous memoranda we select two or three, with which we must close this portion of our work. In the first our readers will, we doubt not, be amazed, as we were ourselves, to find how near the writer was to discovering the telephone in 1837-8.

"20. The plan proposed (101) of propagating communications *by the conjoint agency of sound and electricity—the original sound producing vibrations, which cause sympathetic vibrations in a unison sounding apparatus at a distance, this last vibration causing a renewing wire to dip† and magnetise soft iron so as to repeat the sound, and so on, in unlimited succession.*"

The sheet from which we copy these remarkable words is headed "Exclusive Claims," and seems to have served as an *aide mémoire* to the drawing up of

\* Here we have the germ of the rheostat, or set of resistance coils, as used at the present day.

† *i. e.*, causing a relay to close a local circuit containing an electromagnet. Davy always speaks of the relay as the "renewer," or the "renewing wire." By dip he means to dip into mercury, or, as we say nowadays, to close the circuit.

his patent specification. If our surmise be correct, it would fix the date of the paper as not later than the beginning of February 1838, for we shall see, later on, that he was, in that month, submitting his inventions to Mr. Carpmael, a well-known patent agent of that period. Unfortunately we can find no further mention of the "plan proposed," and can only suppose that Davy designed some kind of telephonic relay.

In the following memorandum the writer could only have in view a form of cell, which is now so well and so deservedly esteemed under the name of its recent inventor, M. Leclanché :\*—

*" A New Galvanic Battery,*

" A particular mode of using oxide of manganese as the electro-negative element of the battery, or in connection with the electro-negative plate.

" Certain other improvements in the battery, which will be described, if there be any opposition on this head,

*" An Improved Magneto-Electric Machine,*

" To be described if there be any opposition on this head."

\* " The new galvanic battery *was* on the principle of Leclanché's ; but, attention having been directed to other matters, it *was* never perfected by me."—Extract from Mr. Davy's letter of October 10, 1883, to the author.

The following extracts are from a paper headed—

*“Elemental Forces and Alarums.*

“There are two objects for which alarums may be required as essential appendages to the Electrical Telegraph.

1st. To give notice that communications are about to be sent, and call the attention of the person who is to receive them. For this purpose alarums of great loudness will not, generally, be required, unless the party be asleep, or not in the same room, and even in these cases a moderate loudness will suffice.

2nd. To give notice of accidents on a railway, or in other cases where the alarum may require to be heard by persons who may be at a distance at the time.

“1st. With the first object an alarum is easily made. One of my horizontal dipping needles (surrounded by its coil) may have an upright rod, as a radius from its axis, with a little hammer on a spring to strike a small bell by the deflection, or dip, of the needle. Thus two needles in the same wire may strike two distinct bells and produce a kind of chime; either one, or both, or variations of which, may be advantageously used according to the intention of the alarum.



“2nd. Whenever an almost irresistible, or, at least, very great power is required, either to produce alarums,



or for any other purpose, I claim the following mode of effecting the object, which is also applicable in other cases where temporary magnetisation may prove insufficient.

“A piece of platina wire, *a*, Fig. 29, connected in circuit with the conducting wire, *b*, and *c*,

FIG. 29. (Drawn from original manuscript.)

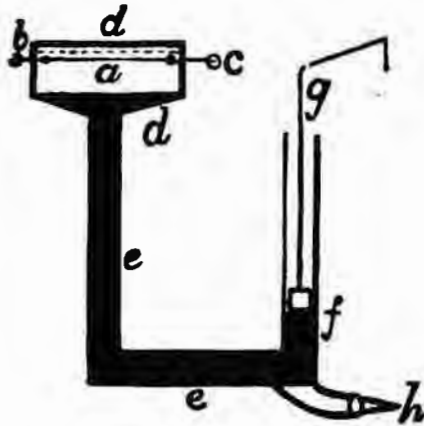

is securely enclosed in an air-tight, and strong vessel, *d, d*, in contact, or proximity, with a quantity of sulphuret of carbon, or other suitable volatile liquid, Then the current of electricity from *b*, to *c*, will ignite, or heat, the platina wire *a*, so as to convert a portion of the volatile liquid into vapour, which will then

expand with a degree of force, proportioned to the heat of the platina wire, and its continuance in a heated state. This will force the mercury, which is below the volatile liquid, through the tube *e, e*, so as to elevate the piston at *f*, and *g*. The force thus obtained may be applied to any required purposes.

“When the current of electricity ceases to pass, the sulphuret of carbon, or other volatile liquid, will re-condense, and the piston gradually resume its former position without the necessity for an attendant to liberate the vapour. Of course a safety valve may be attached, if necessary, either at *h*, or at *d*, or the

self-regulating battery would be useful in combination with this contrivance.

“A continuous sound may be produced by applying either of the above-mentioned forces to open a valve so as to admit air, or gas, from a vessel containing such air, or gas, under compression through a whistle, horn, or other wind instrument. Air, or gas, under compression for this purpose may be provided by the action of dilute sulphuric acid on old iron, on the principle of the hydrogen instantaneous light apparatus, where, as soon as a certain quantity of gas is generated, the liquid is forced into another part of the vessel so as no longer to act on the metal; or air may be pumped in from time to time.”

As we have in one or two places, in the course of these pages, referred to Davy's "Statement," we think it advisable to reproduce this important document, as, while confirming our chronology, it will also serve as an excellent *résumé* of the writer's leading discoveries :—

*“ Statement.*

“The idea of an electrical telegraph first occurred to me about the year 1836, at which time I was not aware but that it was perfectly original. In the commencement of 1837, having tried some experiments with a mile of copper wire in the Regent's Park, aided by my friend, Mr. Grave, I entered a *caveat*, in March, and, about the same time, I deposited

with Mr. Aikin, Secretary of the Society of Arts, a sealed description of my invention, in its then state.

“My earliest idea of applying the deflection of the needle for telegraphic purposes, was similar to that since claimed as a new invention by Alexander, with a common return wire. The next improvement was the obtaining the two actions upon each needle by the reverse currents. Then, the fixing two instead of one needle in each circuit, and subsequently, the system of permutation described, with the use of the colour needles, and the employment of more than one battery. It was at this stage (in March 1837) that I first heard of Professor Wheatstone being engaged on the same subject, which led me to enter the *caveat*. Shortly after this, the idea of the renewing needles [relay] occurred to me. This was after a conversation on the subject with Mr. Bush of the Great Western Railway.

“In May 1837, Messrs. Cooke and Wheatstone applied for a patent, to which I entered opposition, having provided myself with a written description of my inventions, and prepared to attest it by the evidence of several confidential friends. This evidence was partly direct, and partly corroborative. I had Dr. Grant, Mr. Thornthwaite, and Mr. Hebert, besides the workman who helped me to make the models, and the Solicitor-General on some specific, but all-sufficient, points. The paper was carefully inspected by

my friends, who were also present at the hearing on the opposition.

“The Solicitor-General at the time gave an opinion that the two inventions were different, and allowed the patent to pass, although time has since shown that they contained some of the clearest identities.

“My remedies for the injustice thus sustained are, that I may move a writ of *scire facias* to set aside and annul Messrs. Cooke and Co.’s patent, on the ground that the Crown was misled in granting it, or else, or after failing that, to act upon the [my] invention so that they may bring an action for infringement, which I have ample grounds for defending, and the failure of which will *virtually* render their patent void. Litigation of this kind, which will be highly injurious to one party, and but partially beneficial to the other, is what it is in every way desirable to avoid, if the matter can be otherwise adjusted.

“From the time of this decision (May 1837) up to the time of the enrolment of their specification in December, I was in perfect ignorance of the nature of their invention, except in so far as it could be gathered from paragraphs in the newspapers, which conveyed really no information. In the meantime I introduced into my plans first, the use of screens, then the means of determining the signals to specific places exclusively,\* and finally, that which I believe is cal-

\* Re-invented in 1853 by Wartmann. See De la Rive’s *Treatise on Electricity*, vol. iii. p. 783.

culated to supersede all others, the recording telegraph by electro-chemical decomposition." \*

Through the kindness of Mr. Richard Herring, whose name will be familiar to our readers as the inventor of a beautiful recording telegraph, which ought to be better known, we have lately been in communication with Mr. Thornthwaite, one of the gentlemen just mentioned, then Davy's assistant, and now the chairman of the Gresham Life Assurance Society. At our request he has jotted down his reminiscences of this period, which, as corroborative of Davy's "Statement," may fittingly be given here:—

"To J. J. Fahie, Esq.

"London, December 14, 1883.

"My dear Sir,—I find on examination of some old papers that I was a pupil of Professor Daniell in 1834, and that, through the introduction of a mutual friend, I entered the service of Mr. Edward Davy about the end of the year 1835, as pupil and laboratory assistant. Very shortly after entering on my duties Mr. Davy informed me confidentially that he was engaged in some important investigations, the nature of which he could only communicate under a bond of secrecy and an understanding not to make use of the information

\* To this may now be added (1) a block system for railways, (2) the telephonic relay, and (3) the oxide of manganese (Leclanché) cell, besides numberless suggestions of a more or less practical nature, many of which are noticed in these pages.

to his detriment, or to my own advantage. On my giving him the required undertaking he stated that his investigations and ideas had reference to the transmission of signals through great distances by electricity, and the employment of electricity as a motive power, both of which he expressed his opinion were of vast future moment.

“A short time after this conversation he took into his employ a workman of the name of Nickols to make a telegraph instrument to work by the galvanic current causing a deflection of horizontally suspended magnetised steel bars while circulating through coils of insulated copper wire. Each magnetised bar was to carry a light screen of thin paper to uncover and indicate a letter when thus deflected. This instrument, after many modifications of form, was afterwards publicly exhibited in action in the small room in Exeter Hall.

“My engagements in the laboratory prevented my giving much personal assistance in the experiments in Regent’s Park, but I understood they were generally successful as demonstrating the possibility of sending for some considerable distance very distinct signals, amongst others firing a pistol by the agency of a galvanic current transmitted through a thin uncoated copper wire laid on the grass. These experiments were brought to an abrupt termination by our finding one morning that the cowherd had made the curious discovery of some copper wire lying on the grass,

and had amused himself by coiling up and removing the same.

“I have no doubt the idea of using the fulminating silver card as an alarum\* was suggested by a circumstance which occurred about this time. Mr. Davy was sent for one morning by Mr. Minshell,† the magistrate of Bow Street Police Court, and, on his return, he placed on the counter a shallow wooden box, about six inches by three, telling me that it had come into the possession of one of the police officers in connection with some explosive letters lately put into the post, and that, when he arrived at Bow Street Court House, he found the box, containing a brownish powder, being handed about the Court, and its contents being tested even by the smell. On his pronouncing the powder to be fulminate of silver, of sufficient quantity and power to blow the Court to pieces, and liable to explode with the smallest particle of grit and friction, the box was suddenly treated with the utmost respect, and various suggestions were made as to its disposal—the magistrate proposing that it should be taken by an officer and thrown over one of the bridges into the Thames. No one, however, appeared willing to undertake the job. In this state of perplexity, and on the appeal of Mr. Minshell, Mr. Davy took the box and contents under his charge. Having told me these particulars, he said :—‘ Will you carefully separate the powder into small parcels of about a dram each, and

\* See p. 362, *ante*.

† See p. 523, *infra*.

wrap each parcel in two or three papers, and place them separately in different parts of the house for safety.' I need hardly say that I felt an infinite amount of satisfaction when the last parcel was safely disposed of.

"You are quite at liberty to make what use you think fit of this letter, or any part thereof, that may further your efforts, to honour the name of my old friend and master, Mr. Edward Davy.

"I am, yours very truly,

"W. H. THORNTHWAITE."

As showing Davy's wonderful perception of the uses which the telegraph would subserve, as well in the internal economy of railways, as in the political economy of the nation, and of the world at large, we give below the concluding portion of a lecture, which bears evidence of having been written about the middle of 1838: \*—

"The point which now remains for consideration is, of what use will this electrical telegraph be? What are its applications, how will society at large benefit by it, and what inducements does it hold out to private adventurers to take it up as a means of investing capital?

"Now, at the outset of nearly all new propositions

\* Referred to in his letter of 16th June, which see *infra*. "This was given at an institution near Oxford Street, name forgotten."—Extract from Mr. Davy's letter of October 10, 1883, to the author.



of this nature, there are two kinds of objections which we have to contend with. The first arises from the circumstance of the invention being a novelty, and different from all that people have previously been accustomed to. We get laughed at; the matter is treated as a dream. 'Really, sir,' says one, 'you cannot be serious in proposing to stop the escape of a thief, or swindler, by so small an electric spark, acting on a needle; if you had talked of sending a thunderbolt, or flash of lightning, after him, I might have thought there was some feasibility in it.' Another tells us that the experiments are very well across a room, but would not succeed on a large scale. Then, as soon as the practicability of the thing is undeniably established, the same people turn upon us with the question, 'What is the use of it?'

\* There must be some present who will recollect that the first introduction of gas was beset with the same objections. So also were the railroads, and to a certain extent they continue to be up to this time. So also was the steam engine, printing; in fact, almost everything new is discountenanced, or coldly received, by the public at large in the first instance. However, the time has, I believe, already arrived, when the practicability of this

\* "As an instance of how new ideas are sometimes misjudged, even by very intelligent men, I may mention that, in conversation with me in 1837, Dr. Birkbeck, of Mechanics' Institute celebrity, expressed the opinion that the electric telegraph, if successful, would be 'an unmixed evil' to society—would only be used by stock-jobbers and speculators—and that the present Post Office was all that public utility required."—Extract from Mr. Davy's letter of June 11, 1883, to the author.

electric telegraph is no longer doubted, either by scientific men, or by the major part of the public, who have given any attention to the facts upon which the invention rests.

“ I have, therefore, to confine my remaining observations to the uses and application of it. And first, I have a few words to say upon what must be considered as a minor application, namely, the purposes it will answer upon a railway, for giving notices of trains, of accident, and stoppages. The numerous accidents which have occurred on railways seem to call for some remedy of the kind ; and when future improvements shall have augmented the speed of railway travelling to a velocity which cannot at present be deemed safe, then every aid which science can afford must be called in to promote this object. Now, there is a contrivance, secured by patent,\* by which, at every station along the railway line, it may be seen, by mere inspection of a dial, what is the exact situation of the engines running, either towards, or from, that station, and at what speed they are travelling.†

\* In the drawing up of the specification specific mention of this invention was, most unaccountably, omitted. This enabled Wheatstone in 1840 to patent a similar step-by-step instrument, with dial face, &c.

† At every railway station there will be a dial, like the face of a clock, on which, by means of a hand, or pointer, it may be seen where any particular train, running, towards, or from, that station, may be at any particular instant. Every time the engine passes a milestone, the pointer on the dial moves forward to the next figure, a sound, or alarum, accompanying each successive movement.—Davy MSS., No. 11.

Not only this, but if two engines are approaching each other, by any casualty, on the same rails, then, at a distance of a mile or two, a timely notice can be given in each engine, by a sound, or alarum, from which the engineer would be apprised to slacken the speed ; or, if the engineer be asleep, or intoxicated, the same action might turn off the steam, independent of his attention, and thus prevent an accident.\*

“I cannot, however, avoid looking at the system of electrical communication between distant places, in a more enlarged way, as a system which will, one of these days, become an especial element in social intercourse. As the railways are already doing, it will tend still further to bring remote places, in effect, near together. If the one may be said to diminish distance, the other may be said to annihilate it altogether, being instantaneous. The finger of the London correspondent is on the finger key ; and, anon, in less time than he can remove it, the signal is already on the paper in Edinburgh ; and almost as fast as he can touch one key after another in succession, these signals are formed into words and intelligible sentences. These may either have private interpretations attached to them, easily arranged between individuals, or they may be translated according to rule by a clerk of the establishment, supposing such an establishment to be instituted and thrown open to the public like the Post

\* The most perfect block system of the present day does not do anything like this.

Office, on the principle, that any one might send a communication on paying some moderate fee, to be charged according to length. All the practical details of such an establishment are easily chalked out.

“Now, how far would there be sufficient employment, or business, to remunerate the projectors, and how far would the public at large be benefited? Premising that it is a very shallow supposition to consider it as facilitating monopolies, inasmuch as it would be open to all, the first question is, what would be the cost, or original outlay, on a very complete system? I believe about 100*l.* per mile. That would be 10,000*l.* from London to Birmingham, and about 10,000*l.* more, making 20,000*l.*, to bring these towns into communication with Liverpool and Manchester.

“Now, if there be 2000 miles of railway altogether open, or likely to be open ere long, then the capital requisite to carry such an enterprise generally throughout the kingdom would be 200,000*l.*, or about one-fifteenth of what has been expended on the London and Birmingham Railway alone. Let us first confine ourselves to the line of communication between the four great towns, London, Liverpool, Manchester, and Birmingham, at an outlay of about 20,000*l.* When once laid down, the repairs would be very inconsiderable, and very rare. The annual expenses, beyond the interest of the money, would be almost confined to the clerks and superintendents of the establishment, making a total, which, for argument's sake, we will call

2000*l.*, or 3000*l.* a year. Whence will be the revenues to cover this expense, and leave a profit?

“In the first place, there is a certain amount of staple employment, which would be daily and regular. We should inevitably have to communicate the prices on exchanges, the market prices of commodities, rise and fall in stocks and shares. There would be the earliest information of commercial stoppages, arrival of ships with cargoes, and their departures. Then there would be Lloyd's shipping list, as a matter of course, Government despatches, and certain portions of banking correspondence and announcements. Lastly, among the best regular customers would be the newspapers. Public curiosity upon events of importance would ensure that the press would generally get the earliest possible information for their readers, and competition alone would oblige it. There are certain events which would be communicated by telegraph to all the principal towns in the kingdom for publication in the newspapers, as regularly as the publishing day or hour came round. There would be Parliamentary divisions, results of elections, public meetings, criminal news, results of trials of general interest, and the earliest foreign news of all kinds. So much for the regular employment.

“But I conceive that the occasional employment of individuals, for private family correspondence, or for purposes of business, would make up in the aggregate even a far greater amount. Here it is quite impossible

to see how multifarious may be the occasions on which such a means of rapid communication would be of vital moment. Let any individual reflect whether in the course of his life, whether in the course of the past year, there has not been more than one occasion when he would eagerly have availed himself of it, if it had been in existence? Generally speaking, we know that the post is fast enough, and often letters are sent by private hands, when they are many days delayed, and it is of no consequence. But such occasions there are, and though, for argument's sake, I suppose them rare, yet in reality they are not so. If in the population of London, upon an average, only one private person in eight employed the telegraph only once in six months, and received an answer by the same means, at no higher charge than the present postage, say 1s., we should have at once a revenue of 40,000*l.* a year, which I take to be infinitely within the mark.

“Now, what are the occasions on which private individuals would prefer the telegraph to the post? Let us say to announce a birth, or marriage, in a family connection, a death, or sudden illness. No one would be satisfied to convey intelligence of such an event to anxious relatives by any other than the most rapid communication, and if the medium was in existence people would be expected to use it. If one death in ten which take place in London were communicated by telegraph, and that to only one person at a distance, the amount of income from this single source alone

would exceed 1000*l.* a year. Announcements of dangerous illnesses, and daily communications thereon, which would often be transmitted, would considerably exceed even those of the deaths. But this is not all; all sorts of family events, besides births, deaths, and marriages, and all business transactions, as urgent communications between commercial travellers and their principals, errors and oversights to correct before too late, &c., all these would be of no very unfrequent occurrence in every family, or business firm, and taken on the whole, among the great population of this active nation, they would supply the telegraph with as much employment as it could well get through.

“But now some one will say, supposing it all very true that these things can be done, supposing that it will pay very well to speculators, of what advantage will it be to society at large? Railroad travelling is quick enough in all conscience; people used to say that stage coach travelling was quick enough; and some years before that, they were no doubt very well satisfied with the waggons. Now here is a means of communication compared with which the railroad travelling is as a snail's pace. The electrical telegraph can be considered as only one means of facilitating intercourse between distant places; and it is adapted for occasions where all other means would fail. It will in some respects give to persons living at remote distances the same advantages as if they lived in the same street. Should the system ever be adopted

generally throughout Europe, what a vast field does it not open to us. Whatever is going on in Turkey, or in Russia, may be known in London the same hour ; and, though it may seem a bold speculation, I can see no improbability that this will be realised wherever the line of country admits of it. In fact, the greater the distance the more valuable in proportion will be the information communicated.

“Goods ordered from a distant country will, of course, arrive in just half the time they otherwise would, because the outward voyage, or journey, for carrying out the order by letter is dispensed with. On general principles, whatever tends to promote intercourse between distant countries, or distant parts of the same country, will inevitably promote civilisation and increase the comforts of life.

“I must now conclude by stating that the electrical telegraph is already in progress of being established through a considerable line of this country, and there is every encouragement for supposing that it will, without delay, be brought into operation on a still more extended scale. I trust, therefore, that the company present will live long enough to see that, while we have not presumed to use the thunderbolts of Jupiter for destructive ends, we have acquired a command over the same electrical principle, for purposes infinitely more beneficial.”



## CHAPTER XV.

EDWARD DAVY AND THE ELECTRIC TELEGRAPH—  
1836–1839 (*continued*).

HAVING now given a full and impartial account of Davy's many and wonderful discoveries in electric telegraphy, it will be interesting to follow him in the steps which he took to get his inventions adopted. For this purpose we must turn to another class of his MSS., *viz.*, his private letters to members of his family, and chiefly, to his father, Mr. Thomas Davy, surgeon, of Ottery St. Mary. In the extracts which we shall give from these the reader, who knows anything of the similar negotiations of Cooke and Wheatstone during the same period, will find some startling revelations.

At one time his inventions were on the point of being adopted by more than one English railway, and, had he stood his ground but six months longer, there can be no doubt that it would have gone hard with his rivals, Messrs. Cooke and Wheatstone. But alas! just as his labours seemed on the point of fruition, private affairs, which we can never cease to deplore, drove him from England, and, of course, left them an easy triumph. Davy sailed from the Thames for

Australia, on April 15, 1839, and, amid the new cares of a somewhat unsettled Colonial life, soon forgot all about the telegraph. Indeed, we believe that nobody will read these pages with more surprise than the old man himself who is the subject of them.

The first extracts that we shall give have reference to the Exhibition at Exeter Hall, described on pp. 374-78. In a letter to his father, dated January 23, 1838, he says:—

“I write you a few lines in haste, upon a different subject from the last. By the advice of several friends, whom I have deemed trustworthy counsellors in such matters, I have been induced to open an exhibition of my electrical telegraph, accompanied with electrical and galvanic experiments of a somewhat novel nature to illustrate its principle.\* You will observe that the present apparatus is, in appearance and effect, totally different from what you have seen, though founded on similar elementary principles.

“The degree of success of the last three days has been sufficient to encourage me in the correctness of what I have done. I have had Captain Beaufort from the Admiralty to look at it, as well as Mr. Jay, who is superintendent of the Government telegraphs,

\* “This exhibition is accompanied with a variety of interesting experiments, the room *lighted by an enormous galvanic battery*, and, altogether, I have seldom passed an hour more amused.”—Extract from letter in *Mechanics' Magazine*, for February 3, 1838, p. 296.

and who invited me to the Admiralty to-morrow, to examine the telegraphic arrangements, and furnish me with an exact estimate of the expenses of the present system for the sake of comparison. This I think a good introduction. To-day I have had eighteen persons, paying their 1s. each, and yesterday twelve, to see it, several expressing themselves gratified, and saying that they should bring their friends. An old gentleman came yesterday, and to-day he came again with four ladies. He says he is coming again to-morrow with some male friends and others.

“On the principle, *parvis componere magna*, I am led to presume that if the thing were generally known (instead of being merely left to the attraction of a board or two at the door) a great many persons would come to see it, paying their 1s. each, and that thus I might realise a considerable sum [which would be] very acceptable. To make it pretty generally known is impossible without some expense, which, at present, it is out of my power sufficiently to compass. And yet the thing appears to me so promising in success, that I would not willingly lose the chance, after having bestowed so much care, anxiety, and labour on the invention, and having, as I have now the best reason to believe, brought it to greater perfection than any other person. It is my anxious wish, now that every principal expense has already been met, immediately to advertise the exhibition, once or

more, in every principal newspaper, and to take other necessary means of making it public. From present experience I believe the returns will be speedy, and in any case the prospect of indirect advantage to me is sufficient to justify so doing. If I neglect, or am unable to avail myself of, the present opportunity, there are others ready who will instantly take it up.

“Clarke, Palmer, and Cooke himself have been to see it at the private exhibition on Thursday last, and though they could not *immediately* make out the principle on which the effects were produced, yet it is all come-at-able by dint of pondering and patient experiment by such long-headed persons.

\* \* \* \* \*

“From 11 to 5, exhibition hours, I have scarcely had time to warm my fingers in the late bitter weather, from the all-sorts of questions, explanations, illustrations, demonstrations, &c., I have had to deal forth to the learned and unlearned—the former being the least troublesome.”

A few days later he wrote to the same address :—  
“The exhibition to-day had about the same number of visitors within two or three, which, all things considered, is pretty well, and, if continued, would set aside all apprehension of losing by it.

\* \* \* \* \*

“Among the visitors were Lord Euston and his son, who were pointed out to me by a gentleman

present. Mr. James Wheeler, my old master's brother, was there. He was at a lecture at the Royal Institution last week, when Cooke and Wheatstone's telegraph was exhibited, and said that, on comparison of action and effect, he much preferred mine. He also said that theirs would be rather advantageous to me than otherwise, as the public would soon draw the parallel.

"It is my earnest desire now to make the thing promptly known in every direction [by advertising largely].

\* \* \* \* \*

I calculate that by the time 1000 persons have been to see the telegraph their retail conversation will be enough to dispense with other advertisements than rare and occasional ones, because, out of 1000 persons on an average computation, 100, by their gossiping propensities, will act as walking advertisements.

"I have with me a boy who is remarkably sharp and handy at repeating the experiments. \* \* \* The little fellow appears to be able to understand anything he has once seen, and has, moreover, a very good address, asking for the One Shilling, Sir, or Madam, very genteely, &c.

"You did not expect to have a son turn showman, but I trust I am merely instrumental in promulgating a useful discovery, and that you will live to see it established, generally, throughout the country. I

must *endeavour* to persuade the Admiralty to lay it down from London to Chelsea, or Putney, for experiment, this being the most foggy part of the line towards Portsmouth; but I fear they are too stingy of the revenues of the nation. I rather expect that some enterprising individuals will take it up for public use. Time will show.

“P.S.—Receipts to-day about 25s. Among the visitors was pointed out, after he had left the room, Earl Grosvenor.”

Towards the end of February, 1838, he wrote:—

“My dear Father,—My business with Mr. Welch is concluded—my lease cancelled—and I am no longer the occupier of the house 390, Strand. Please, therefore, address to me at Mr. Smith’s, 199, Fleet Street.

\* \* \* \* \*

“As we some months ago prognosticated, the telegraph, being once promulgated, has interested the public, and is in a fair way to be generally adopted. The Great Western Railway have decided upon laying it down upon their line, and the only question, both in this, and in all subsequent cases, will be, whether my plan, or that of Cooke and Wheatstone, be preferred.

“Mr. Brunel, Junior, Engineer to the Great Western Railway, with Mr. Tite, and other Directors of the company, came to see my apparatus, and wished

me distinctly to point out the advantages which it possessed over the rival scheme. Mr. Brunel, being on intimate terms with Mr. Cooke, was somewhat inclined to lean the other way, but the principal difficulty under which I laboured was the impossibility of rendering manifest all the advantages of my mechanism, without entering, more or less, into such explanations as would, more or less, betray my secret—as yet unpatented. When, therefore, I stated that I could effect such and such objects he could not see how it was possible—thought the attempt would be dangerous, or precarious. Seeing also that I employed six wires, he could not conceive but that my plan must be an infringement upon the patent of Cooke and Wheatstone, and that the company could not safely carry it into execution without risk of action for damages, &c.

“Moreover, that, as I was not prepared fully to develop my plans, I could not be considered in a condition to treat with them, for they would have to buy of me what he designated ‘a pig in a poke,’ which, though it might produce very pretty effects, yet, as the *rationale* was not open for canvass, its practicability could not fairly be judged of, nor could he confidently assure the company but that it might prove to be an infringement on the others’ patent. Mr. Brunel is a particularly sharp, intelligent man, capable of comprehending anything in all its bearings, and of improving the barest hint. I had, of course,

to be on the alert to divulge nothing that would impair the security of a future patent-right. I could not fail to learn something from him, and the result of this interview has been to prove to me the necessity of ascertaining, with the greatest care, the precise footing upon which I stand, before taking any further steps. I have endeavoured to persuade the company to delay a week, or two, before they ultimately decide on adopting any plan.

“In the meantime, my first object will be to obtain the opinion of the most eminent lawyer in patent affairs, and I have been nearly all this day engaged in conference with Mr. Carpmael upon the subject. This may cost me two or three guineas, but will be infinitely cheaper than a blindfold course of proceeding. To-morrow I shall get his opinion. Should this be favourable to my views, I shall almost think it right to obtain a second opinion of some eminent barrister, or of the Attorney, or Solicitor-General, before venturing to act upon it. But if fully confirmed as to my right to secure as exclusive, and to act upon, or license others to act upon, my own invention, there can be little question as to the peremptory necessity for immediately raising funds to take out a patent, which will place me on a par, or more than a par, with Cooke and Wheatstone. The time has now arrived when the thing is on the point of being acted upon throughout Europe.

“As to the particulars of my mechanism, there are



guesses enough at it, but, though it is simple as can be, the guesses are as far wide of the actual truth as need be. Mr. Cooke himself is in perfect ignorance of it.\*

"I hope, in a postscript, to subjoin Mr. Carpmael's opinion. He told me this evening that, though he would not record it on paper until he had investigated the matter fully, yet his present impression was that the two inventions [*i. e.*, Cooke and Wheatstone's and his own] differed most essentially in all main points, and that a separate patent might be obtained and maintained without hazard of litigation. He has appointed to-morrow morning to inspect my mechanism (of which as yet he has seen the description only) at 10 o'clock, at Exeter Hall.

"28 February, 1838: I enclose a copy of Mr. Carpmael's opinion.† I am now passing the patent through the first stage, which will cost about 12*l.*, but beyond this, unassisted, I shall not be able to go. Mr. Carpmael thinks it may not be difficult to get some one to advance money for future patents, if I can only place myself in a condition to explain, by

\* "I have sufficient reason to know that the true principle of [my apparatus] has not been discovered by any one, not even by Mr. Wheatstone. I have purposely, and for a veil, allowed it to be supposed that the principle is the same as that in Mr. Cooke's invention, which, as I designed, is taken for granted."—Davy MSS., No. 10.

† This document, copied by Davy himself, is preserved amongst his MSS., No. 11. It bears the date February 24, 1838.

securing the English patent first, after which it will be just as desirable to do the same thing in Belgium, America, and other places.

\* \* \* \* \*

“ Your ever affectionate Son,

“ E. DAVY.”

“ May 30, 1838.

“ My dear Father,—This long-pending decision upon my application for a patent has at length been given. I believe I told you that, owing to the Solicitor-General not being able fully to comprehend some points, it had been agreed to call in the assistance of some eminent scientific man, and, accordingly, Mr. Faraday was referred to as being the highest electrical authority in the kingdom, and he was kind enough to undertake [the examination of the points in question]. The result has been in my favour, *i. e.*, I am entitled to the patent I am applying for with the retention of every point of the least value. The Solicitor-General's report will be ready for delivery to-morrow, Thursday, and then all that will be wanted to proceed with the patent will be the money. It will then take about ten days to pass the Great Seal, and until that there is no security for it, and I will still labour under the difficulty of not being able to explain its nature, or

advantages, to any one so as to get it taken up. Besides, there is every day the risk of persons finding out the particulars for themselves.

“Once the patent secured, I think it not improbable that it may end in a compromise with Cooke and Co., for when I have the patent I must get connected with some one possessed of capital. They have, I understand, already laid out 2000*l.* upon their telegraph, and are very anxious at present, as Mr. Wheatstone told me they were in treaty with some of the great railway companies, but that the latter delayed coming to a decision, understanding that there might probably be another patent in the market. So, if I pass my patent, they will either have to wait six months to see the specification, or else offer me terms at once.

“Whether the Great Western is the company alluded to I know not, but I had previously been given to understand by Mr. Gibbs that they had already contracted with them, and were going on with the preparations (as I was told by a different party) of coating an immense quantity of copper wire with india-rubber. It may, therefore, or may not, be some other great company.

“I am happy in being able to communicate the intelligence contained in this note, for, from the long and vexatious delay, I have been not without apprehension that the decision would be against me. The

circumstance of Mr. Faraday having been called in will also render the patent safer, as his opinions on such matters would naturally be looked upon by the public with some confidence.

• • • • •

“With kindest loves, believe me,

“My dear Father,

“Your ever affectionate Son,

“E. DAVY.

“P.S.—I enclose a copy of the claims upon which Mr. Faraday advised that my patent might be granted. You will perceive that it contains the most important points.”\*

“June 16, 1838.

“My dear Father,—I have only time to say that I received from Messrs. Gibbs 130/., and Mr. Carpmael informs me that the patent will be sealed early in next week. I must write you again to explain what I purpose doing as soon as that is accomplished, *viz.*, to send circulars immediately to all the Boards of Directors of Railway Companies, and to give one, or more public lectures on the subject, inviting as many influential people as possible to attend. It must now

\* This document is preserved amongst the Davy MSS., No. 11.

be pushed forward with all our might and main, and I hope it will not be long before it does some good.

“ You will soon hear from me again, and believe me,

“ My dear Father,

“ Your ever affectionate Son,

“ E. DAVY.”

“ June 23, 1838.

“ My dear Father,—I think that I ought to give you notice from time to time of my moves with the telegraph, in order that, in case of any sudden accident to me, and the concern being in a promising state, my successors might know better where to take it up, and what I had been doing.

“ The patent has not yet passed the Seal. I expect that it will about Wednesday, or Thursday next.

“ I have been endeavouring to make connections with some business men, to assist me in making negotiations with the railway companies, or in getting up a general telegraph company.\* The principle on which I endeavour to engage their services is that of percentage on whatever money I may obtain for licenses under my patent, through *their particular influence, or interference*. The amount I have fixed upon is 10 per cent., which will, perhaps, be liable to deviations in some cases. The present difficulty is in getting the thing *started*. When known practically

\* A few letters to and from business men and Railway Boards on this subject are preserved amongst the Davy MSS., No. 11.

and appreciated, it may be that the companies will come to me, instead of my having to seek after them.

“The best business man I have at present retained is Mr. P—— \* \* \* I requested him to apply first to the Birmingham Railway Company, and the subject has been brought before the directors. The only answer obtained is that, if ever the directors should deem it necessary to adopt any electrical telegraph, they will make the most minute and careful examination into the comparative merits and advantages of each plan before deciding on either. I saw Mr. Creed, secretary to, and original getter-up of, the Birmingham Railway Company, who told me only that he would be happy to receive any memorial from me on the subject of my invention in order to lay it before the directors. Mr. P—— is to introduce me to their domestic engineer in about a week.

\* \* \* \* \*

“Mr. P—— is next about to apply to the Southampton Railway, and I am now preparing letters\* for him to make use of, setting forth that, when once laid down, the Admiralty will, no doubt, be glad to make advantageous contracts with them for the use of it for Portsmouth, which is at no great distance.

“We must, of course, rake our brains to find out all the inducements we can to tempt people to these speculations.

\* Original drafts of these preserved.—MSS., No. 11.

"That will be the next move. Then there will be the grand junction from Birmingham to Liverpool and Manchester.

"The next business man I hope to retain, and have partly, is Captain B——. He is intimate with the engineer of the Birmingham and Gloucester Railway, and has influence with the Midland Counties Railway, either of which would be a good step.

"Another is Mr. B——, of whom you have heard before.

• • • • •

"I have an appointment to meet a capitalist, name as yet unknown, at three o'clock on Monday about money for taking out the foreign patents, all which may, or may not, come to nothing. Another appointment with a broker, named L——, to aid in getting up a company, at four o'clock the same day. There are many of these appointments for the one that leads to any result. Therefore, do not be on the look-out for such results, I will be sure to tell you if anything good comes. It is no use to be either sanguine, or easily put out of one's opinions.

"Believe me, my dear Father,

"Your ever affectionate Son,

"E. DAVY.

"P.S.—My impression at this moment is that it will be better, if possible, to get up a general company,

and sell the patent out and out, particularly as the Birmingham directors scarcely appear to comprehend the advantages of the system further than for mere railway uses. It will, I know, be a very difficult matter to get the proper people in the mind for entering into such a scheme. Mr. Hesseldine appears to listen to the proposition, but has some objections of which I cannot clearly see the drift, unless it be this—that the Government could scarcely allow such a powerful instrument to be in the hands of individuals, or a private company, and would either prohibit it, or else take it under their own management; and, therefore, that the best possible parliamentary, or government, influence ought to be made in order to secure the probability that such future arrangements with the Government may be advantageous to us.—I know very well that the French Government would not permit it except in their own hands; but though I think our Government ought, *and, perhaps, will eventually take it upon themselves as a branch of the Post Office system*, yet I can scarcely imagine that there would be such absurd illiberality as to prohibit, or appropriate it, without compensation.

“There is, however, prudence in what he suggests as to making friends in high places, if it can only be done.

“Are there any of the directors of the Bristol and Exeter Railway with whom interest could be made? They are, I believe, in great part Exeter people.”



“ July 4, 1838.

“ My dear Father,—It was not until this morning that my patent actually passed the Great Seal. It is now secure for England and Wales, and you will see it in the list in the next *Gazette*.

“ The enclosed was written some time back. It may be well to preserve whatever details I send you with regard to the telegraph.

“ My object now is to get a company formed to take my patent off my hands, and, either pay me a large sum down for it out and out, or else a smaller sum down, and an agreement for a further remuneration hereafter, and proportioned to the success of the scheme, such as a percentage on dividends, &c.

\* \* \* \* \*

“ There is plenty of money in the market, and plenty of people ready to vest it in such schemes, if they can only be satisfied that they will pay more than 5 per cent. interest. All I have to do is to make people believe this, and the money will come without any pressing on my part. But this *is* the difficulty, and one which I have now to make every possible exertion to overcome. The practicability of the plans will, I believe, not be much longer doubted. I have several persons at work to get some influential names sufficient to head a prospectus\* as Directors, &c., and find

\* A draft of such a prospectus, headed “ Voltaic Telegraph Company,” is preserved in the Davy MSS., No. 9. It is a powerfully-written and exhaustive document, and will well repay perusal. *À propos*

current expenses of printing, advertising, journeys, models, &c.

• • • • •

“ Mr. P.— says that ‘ before forming a company, we must first secure the consent of some railway company to the laying down of the wires upon their line on certain terms. If one railroad will do this, we may afterwards reason that others will agree to the same ; otherwise people will say, ‘ How are you going to enforce permission from the railways, or turnpike trusts, without an Act of Parliament ? ’ Now, I don’t see that the want of previous agreement with a railway should at all deter us from endeavouring to form a company, but it is clear enough that such an agreement, previously obtained, would be a step gained, and an argument in our favour. With this view an appointment is now pending with the domestic, or resident, engineer of the Birmingham Railway.

• • • • •

“ I have had notice of another application for a patent by a person named *Morse*. Messrs. Cooke and Wheatstone have entered an opposition to this application, and I shall have to do the same, so that one, or other, of us may be able to stop it. We are now

---

of the name, the following memorandum may be quoted :—“ A satisfactory name is not yet decided on. It might be called the ‘ Oerstedian,’ after Oersted, the Danish philosopher, who first discovered the magnetic powers of electricity ; or the ‘ Instanterian ’ ; but a better name may turn up.”—MSS., No. 11. In another place Davy speaks of a system of *Electroloquism* ! (MSS., No. 7).

both equally interested in keeping a third rival out of the field, and it may save much after trouble and competition. \* \* \*

“Your ever affectionate Son,

“E. DAVY.”

In a letter to the same address, dated July 21, 1838, the following passage occurs :—“I find the people who undertake to make appointments about the telegraph very dilatory in so doing, which prevents my making progress as fast as I could wish. I trust the prospectus will be a help.

“It is not every one who is willing to be a director that will suit, as I wish to confine it to the highest respectability, and avoid all poison. Mr. E—— has evidently his enemies, but if I can find that he has also his friends, he will be a valuable acquisition, having much money and connections, and I believe he would liberally support me, or lend his voice to pay me a large sum.”

Two days later he wrote :—“I had a further conversation with Mr. P—— on Saturday. He expects an appointment with the engineer in question [? Mr. Fox] on Tuesday, and entertains a hope that we may also secure Mr. ——, the chairman of the Southampton Railway Company, than whom, for one, we need not have a better. Mr. P—— having considered the prospectus, and suggested some slight alterations, said that, now the thing was distinctly laid

out, his views had quite altered, and he should have a difficulty in seeing how the thing should do otherwise than 'pay' to the shareholders. He would be the managing director, or whipper-in, as he is in the A—— Mining Company. As I have but slender acquaintance among the great commercial people, I am obliged to apply to, and make use of, persons of this kind, and I believe he is well known and knows many, and that his persuasion may have some effect, where I should not be listened to. The difficulty is to get him to stir himself sufficiently. I do not anticipate much good from either Captain B——, or Mr. B——, but perhaps they may be of some aid."

" July 30, 1838.

"My dear Father,— \* \* \* I had an interview on Wednesday last with Mr. Fox, resident engineer of the Birmingham Railway, the whole particulars of which I can scarcely enter upon at this moment, except that it was quite satisfactory and friendly, as far as it went. The main purport of it was that if we had a company who would go to the expense of laying down the wires, &c., the railway directors would willingly grant the use of their line and afford every facility and protection, on condition only of a license under the patent as far as relating to railway purposes only.

"This has been one of the problems, 'How is the Telegraph Company, without an Act of Parliament, to lay down the wires?' He says there is no doubt

that few of the railway companies will object to these terms. Mr. P—— has promised to-morrow to see the Southampton Railway people, and I shall have another interview with Mr. Fox for further explanations, so that I trust we shall soon be enabled to come before the public ; but it is a tedious business.

“ 31st July.—Since writing the above I have received M. A.’s letter and enclosure, to which I shall give the earliest attention. You may presume, if you do not hear from me for some little time together, that there is nothing particular going forward. I understand the directors of the Great Western Railway are under discussion to ascertain the nature of my patent, but I shall take no notice at present.—With kindest love, believe me,

“ My dear Father,

“ Your ever affectionate Son,

“ E. DAVY.”

In a postscript to a letter dated Aug. 1, 1838, he writes :—

“ I spent yesterday evening with Mr. Fox, explaining my inventions to him. He expressed the most favourable opinions of them, and, if he does not alter his mind, we may consider the Birmingham line as secured, or nearly so. He is the sharpest and quickest man I have yet had to talk to, comprehending everything before it was half explained, and suggesting improvements, or remedies for difficulties, &c. We are in other quarters making slow but, I trust,

effective progress, and the chances against eventual success appear daily diminishing."

" August 17, 1838.

" My dear Father,—Mr. P—— has had interviews with Mr. Easthope and his son. Mr. E—— seemed to take very enlarged views of the applications of the telegraph, and the revenues to be derived from it, and promised his strenuous influence for its immediate adoption on the Southampton and Portsmouth line, of which he is chairman of the directors. The conversation, as repeated to me, coincides with my own (perhaps sanguine) idea to an extent which I have never had the satisfaction of meeting with before. Mr. P—— came home quite red-hot upon the matter, sees it in a new light, and has this morning agreed to take out the principal foreign patents (to find the money and have half), on condition that I would also give him a further interest in the English patent already obtained. I have, consequently, agreed that he shall pay me 150*l.*, and have one-fourth of the patent right. This I have done, not but that the patent may be worth far more than four times 150*l.*, but with ulterior objects, to secure his interest and exertion to help it on, for I could do little by myself. And it appears to me the remaining three-quarters may be thereby increased in value more than they will have lost. I do not suppose that Mr. P—— will go from this arrangement, which yet remains to be executed. He says, that, if sufficiently interested, he will devote nearly all his time to it.

“ I spent yesterday evening and took tea with Mr. Fox, resident engineer of the Birmingham Railway. I have his decided approbation of my plans, in preference to those of the other party, and, therefore, a powerful voice is secured on that line. We had much conversation on various details of the subject, but it takes time to work people into an acting humour. Until now Mr. P—— has been lukewarm, or, at least, tardy, in his movements. The encouragement, which Mr. Easthope has given, has put a new life into the thing.

“ I believe I told you that Mr. Easthope is a Member of Parliament, proprietor of the *Morning Chronicle*, and a large shareholder in the Southampton, and in the Havre and Paris Railways. He is, perhaps, as good a patron as could be obtained for one. He said that the subject was not new to him, and that it had been frequently under discussion in society where he had been.

“ You will perceive that if I have been in error as to the prospects of this invention, I have now some people of high standing to keep me in countenance in the ‘moonshine.’ Mr. Easthope speaks of its opening communications between London, or Liverpool, and the Mediterranean! With kindest love to all the circle, believe me, my dear Father,

“ Your affectionate Son,

“ E. DAVY.”

About the end of August, or beginning of September, 1838, he wrote :—

“ My dear Brother,—I have just received a packet enclosing, among others, a letter from you. You will perceive by my communications to Father, &c., that I am trying hard to dispose of my telegraph. I wish to get it clean off my hands, and, if possible, an employment in laying it down at an annual salary. I believe I may now almost calculate on the Birmingham Railway, the best line in the kingdom ; there is little now to fear from the rivals, Cooke and Wheatstone, and there are no others. My object is to form a company of affluent people, who will purchase my patent right, and, if this succeeds, it will produce a large sum of money, as 10*l.* or 20,000*l.*, just as easily as so many hundreds. The value of the invention has very greatly increased since what it was six months ago, and I would not now sell it to Cooke and Co. for any sum they would be likely to offer, and which I would gladly have accepted once.\* I have every assurance that I shall get together a set of wealthy directors, and that the shares will be taken up. We have, as you will perceive, some first-rate people already engaged, and much interested in it. Mr. Wright could, if he chose, advance 200,000*l.* We

\* From a letter of Wheatstone to Cooke, in Mr. Latimer Clark's possession, dated July 18, 1839, it seems that they then contemplated buying up Davy's patent. Ultimately it was bought for 600*l.* by the old Electric Telegraph Company, and—smothered, like a good many others. See letter of May 12, 1847, amongst the Davy MSS., No. 12.



are promised the Marquis of Douro and Lord Sandon for trustees, through the interest of Messrs. Mac-Dougall, the solicitors in Parliament Street. There is no present reason to apprehend but that I shall get my price for it by persevering and securing influence step by step. But for all this my presence here is indispensable. It would come to nothing if I left London at this juncture which would be madness. There is no one able, or willing, to push it forward for me, and, if allowed to sleep, the patent would not be worth a rush. I am now anxious to connect with some sharp, wary solicitor, not too young, whom I can engage to protect my own personal interests in driving the bargain with the directors, which will be very essential—one is so apt to be talked over by these keen monied men.

\* \* \* \* \*

“The enclosed piece of paper contains a statement of the progress made in organising our company. Only the names with asterisks are fully secured, but the others we have not much reason to doubt of.

“When a meeting of the directors can be called together, I shall propose that as soon as the deposits are paid up they give me 10,000*l.* in money and one or two thousand shares ; in fact, the best bargain I can make. Something will come of it.

“Your ever affectionate Brother,

“E. DAVY.

“P.S. Exeter Hall cannot be said to pay at present. It is kept open rather to answer a purpose in getting up the company.”

The above letter, as appears from another to his father of September 9, 1838, was written to his brother, Henry Davy, about the end of the previous month.

The piece of paper referred to contains the following :—

**TRUSTEES.**

Marquis of Douro, and Lord Sandon.

**DIRECTORS.**

\*Sir F. Knowles, Bart., F.R.S.

\*John Wright, Esq., Banker.

Em Tennant, Esq., M.P.

Mr. Bagge (of Norfolk), MP.

Mr. Harrison (Chairman of the  
Southampton Railway).

**ENGINEER.**

Mr. Fox.

**SUPERINTENDENT OF MACHINERY.**

E[dward] D[avy].

**SOLICITORS.**

\*Messrs. M'Dougall and Co.

Capital £500,000 in 10,000 shares, £50 each, deposit £5.

In a letter to his sister, dated September 22, 1838, he says :—

“I am obliged to remain in, or near, London, on account of the telegraph, as there is a probability that the arrangements with the Southampton Railway will soon be completed. Nothing is certain as yet, but

the directors appear decided upon having one on their line. The Birmingham line also is in prospect.

“ I have sent a circular to all the principal railway companies. The Grand Junction say they have no intention of adopting any telegraph at present, and the Birmingham and Derby seem to imply, in their answer, that they have it in contemplation, and will take it into consideration as soon as they are prepared to do so, &c. All that could be expected from the circular was to prevent them from engaging with the other party before they knew anything about me.

“ The idea of forming a company is suspended for the present, on account of the opinion of the Southampton Railway directors, that all the railway companies would eventually take it upon themselves, and find the capital. If so, it is all that is wanted.

“ I presume that if terms are made with the Southampton, which is the first company that is likely (being on the line of the Government telegraph to Portsmouth, and having a probability of a contract with the Admiralty), they will require me to superintend the laying it down at a salary, independent of the remuneration for license under the patent.”

On October 8, 1838, he writes to his father :—“ I have done all I can to bring my patent before the Southampton Railway Company, and have received every assurance as to their intention of adopting it. I must now wait their final decision if they do so as to the precise terms, and also as to the time when they

will be ready to commence operations. What I have proposed to them is, that they shall be at all the expenses, pay me one-third of the net profits, and employ me, at a reasonable salary, to lay down the telegraph and keep it in repair.

“I will shortly make an attempt to urge forward the Birmingham Company, where, I believe, I have sufficiently secured the preference. As soon as one of these companies brings the telegraph into operation along the entire line, and it is found to answer, the others will quickly follow.

“The Polytechnic Institution, after giving much trouble, declined purchasing the Exeter Hall model, and I am now in treaty for it with a Mr. Coombes, an American, who proposes to take it home with him, and open an exhibition, with some other models, in his own country. I have closed the Exeter Hall room, and paid off Mr. Spicer, my assistant, and also Downy, the other man who used to attend there.”

Again on November 17, 1838, he says:—“I have made some arrangements with Mr. Watson, rather on the principle of co-operation than of actual partnership, and have pretty well explained to him how I am situated. \* \* \*

“You will perceive I am anxious to be doing something, independent of my expectations from the telegraph. I have put it into as good a position as possible, and have no doubt of its final success; and must now wait the answer from the Southampton

directors, who have verbally promised its adoption, as well as from other quarters. I shall not let the matter go to sleep, but as it is in a channel, and as my interference will not hasten it, there is little to be gained by thinking of it; so I must be doing other things.

“There is no relying on Mr. P——. He agreed to purchase a fourth of the patent for 150/., and was red-hot to conclude the bargain, but after a few days he told me that he could not at present provide the money. I cannot help these disappointments.

“Mr. Fox is steadily friendly to me as yet.”

“November 29, 1838.

“My dear Father,— \* \* \* I have got rid of my room at Exeter Hall, which, now it is no longer required, is a saving of 14s. a week. Altogether it has somewhat more than paid its expenses, or thereabouts. It would doubtless have done better, but I was driven from personally attending to it by incessant annoyances. It has, however, answered more effectually by the notoriety which it has given to the telegraph. You will perceive by a number of the *Railway Times* which I shall enclose, a reason for the delay in the decisions of the Southampton Company, *viz.*, the question whether they would obtain the branch line to Portsmouth. Mr. Easthope is a spirited man, by whom many other monied persons are guided, and he has influence with the present Government. I have as yet no reason to doubt that he will keep his word with

me, that my telegraph shall be adopted immediately they are prepared to commence operations with it.\* The bringing this to bear may be a work of some little time, as such things usually are, but I am sure you will not regret the attention I have paid to it, nor even the manner in which it has diverted me from my other business; nor do I think you need feel doubtful as to its eventual success. The next month will be occupied with completing the specification (due Jan. 4), much of which will have to be remodelled by Mr. Carpmael's direction. Everything depends upon this being as perfect as it can be, and I wish I were more fit for the task, by having a mind more at ease than is at present possible.

\* \* \* \* \*

\* The following extract is *à propos*. It is from a letter of Wheatstone to Cooke, now in Mr. Latimer Clark's possession, dated July 18, 1839:—  
 "Now on another subject, Mr. Easthope, the chairman of the board of directors of the Southampton Railway, wishes to see the telegraph at work. Will Saturday next be a convenient day for the purpose? If so, I will bring him with Mr. Irving and Mr. Wright, the banker. This visit will be an important one. He is fully impressed with the advantages which may result from the invention, and I think would not be disinclined to encourage it. I need not say that he is a person of influence and wealth.

"One great difficulty with respect to him and the railway with which he is connected is now obviated, for I understand he gave considerable encouragement to Davy so long as he thought his plans likely to succeed."

It will be remembered that at this date Davy was in Australia, and "his plans" in the hands of people who did not understand them. Naturally, then, Mr. Easthope turned to Cooke and Wheatstone. It is also interesting to note that Mr. Wright was one of the fully secured directors of Davy's proposed Telegraph Company. See p. 439.

"I have to-day been informed that the Brighton Railway Company are about to adopt an electrical telegraph, which is a quarter in which I scarcely expected it. I must look after them to ascertain if it is correct, for Mr. Cooke is making all his interest. I think the London and Dover will be a better line, but will not be complete for a long while. I am obliged to employ a good deal of Nickols' time on the working model, which will be the principal thing in the specification, in order that it may be ready to show at work. The month after the specification is enrolled it will appear, at length, in the *Repertory of Arts*, a number of which I shall purchase and forward to you. With kindest loves to mother, brothers, and sisters, believe me, your ever affectionate Son,

"E. DAVY."

"December 12, 1838.

"My dear Mother,— \* \* \* My specification must be enrolled by the 4th January, and afterwards will be published, gratuitously, by the patent agents, in the *Repertory of Inventions*. This also I shall have to look to, procure a few copies, and send them to the parties most likely to serve us. After this, for aught I know at present, there is little more I can do to forward the matter, and it must wait the good time of the railway directors to take it up, which there is no reason to doubt nearly all of them will do eventually.

"I believe I have effectually barred any hasty

adoption of Cooke and Wheatstone's telegraph, which has made no further progress.

"You must be aware that, although it may come into operation almost immediately, yet it may possibly not until some little time hence ; but this is a question which now rests with others, and not so much with me, and we must not, therefore, be disappointed at some delay.

\* \* \* \* \*

"Your ever affectionate Son,

"E. DAVY."

We have arrived at the end of our MSS., and, consequently, at the end of our task, which, we need hardly say, has been to us a labour of love ; but before dismissing the subject we cannot resist the pleasure of quoting two short passages,\* which will serve to show in what estimation Mr. Davy was held by those most capable of comprehending his character. The first is from Mr. Thomas Watson, Dentist, London, a gentleman of great scientific attainments, to Davy's father :—

"May 20, 1839.

"My dear Sir,—I have to apologise for not acknowledging the receipt of your kind present ere this, an exceeding pressure of business must plead my excuse.

"Permit me to say that any service I may have

\* Davy MSS., No. 12.



rendered your son has been to me a source of much gratification. I much regret, upon private grounds, that by his absence I lose an acquaintance which I highly prized, while, upon public grounds, science has lost an adjunct as talented, as zealous, and, without flattery, I must add *his pursuits would have so enlightened and benefited his countrymen that his secession to the primitive shores of South Australia must be deplored as a national calamity.*

\* \* \* \* \*

“Believe me, yours sincerely,

“THOS. WATSON.”

The next extract is from a letter (October 21, 1839), of Charles Pain, the family solicitor, of Surrey Street, Strand, to the same address:—

“Mr. Carpmael passed some high encomiums on your son’s talents in matters of science, and said he considered *his leaving England a great loss to the country*, and he particularly regrets his absence on account of the telegraph, which, had he been present, he would have had no difficulty in disposing of to the Great Western Railway Company, who are now adopting that of Messrs. Cooke and Wheatstone, and to whose, he says, your son’s is very superior.”

The rest can be told in a few words. For a year or two after Davy’s departure for Australia, his father and one or two friends tried, but in a half-hearted way, to carry on the negotiations from the point where he

himself had left them. Another exhibition of both the screen and recording telegraphs was opened in Exeter Hall for a few months in 1839-40, but, as those in charge of the instruments did not thoroughly understand them, and could not always get them to work satisfactorily, no good came of it.

The machines were sent down to Ottery St. Mary at the end of 1840, and were stowed away in an out-house as so much rubbish. In the hope of rescuing them we lately paid a visit to Davy's native place, but found, to our grief, that only three years before, on a change of residence, they were broken up and sold as old metal! Our informant, the family gardener, added "'twas such a pity, as there was as much mechanism about them as would fit up a hundred clocks!"

In a field we found some pieces of cotton-covered iron and copper wire, and six of the Daniell cells—huge things of three or four gallon-capacity.\* The outer jars are of glazed earthenware about eighteen inches high, and the porous pots are more than half an inch thick! These relics will now be carefully preserved.

And so ends the story of a *magnificent failure*.†

\* Two of these are now in the Library of the Society of Telegraph-Engineers and Electricians. Nov. 15, 1883.

† In the belief that our readers will now be interested in everything relating to Mr. Davy, we have collected a few biographical notes of the venerable pioneer, which will be found in the Appendix B, to this volume.

## CHAPTER XVI.

TELEGRAPHS BASED ON ELECTRO-MAGNETISM AND  
MAGNETO-ELECTRICITY (*continued*).1837.—*Alexander's Telegraph.*

IN May 1837, William Alexander, of Edinburgh, published a scheme for telegraphic communication, which was the realisation of Ampère's and Ritchie's ideas. It was widely noticed at the time, having appeared in the following amongst other journals:—*Edinburgh Scotsman*, July 1, and November 18; *Edinburgh Evening Courant*, July 3; *London Times*, July 8; and *London Mechanics' Magazine*, August 12, and November 25, 1837. In this paper he showed the practicability of his project; estimated its cost; and pointed out its utility as well to the public as to the state.

After a brief reference to the then existing system of semaphoric signalling, he says:—“The plan of a telegraph underground, by means of electric or voltaic currents, transmitted by metallic conductors, was some time ago devised, and its practicability supported by electricians of eminence; but their ideas on the subject have not hitherto been matured,

\* We quote from his *Plan and Description of the Original Electro-Magnetic Telegraph, &c.*, 8vo., 30 pp., London, 1851.

or carried into actual practice upon the scale which is now contemplated.

“ It has been found by experiments made with a view to ascertaining the velocity of electricity, that it is transmitted instantaneously, by means of a common iron wire, a distance of eight miles ; and electricians of the first eminence have declared their opinion that, judging from all scientific experience, the electric or galvanic influence would be almost instantaneously transmitted from one end to the other of a metallic conductor, such as ordinary copper wire of moderate thickness, of some hundred miles in length.

“ If this scientific theory is correct, it follows that a wire, secured by a coating of non-conductors, and protected from external influence or injury, and laid under the turnpike road between Edinburgh and London, could be the means of distinctly indicating to a person stationed in London that such wire had been electrified or galvanised in Edinburgh—the transmission of the electric or galvanic influence being clearly discernible by various well-known means.

“ How, then, is this scientific fact to be applied to purposes of practical and general utility? Simply by laying as many wires, separated from each other, as will correspond to the letters of the alphabet, and preconcerting between the persons stationed at two extremities of the line of communication that each individual wire is to represent a particular letter ;

2 G

because, if the person stationed in Edinburgh can, by applying the electric influence to any one wire, instantaneously apprise another person stationed in London that a particular letter of the alphabet is thereby indicated, words and sentences *ad infinitum* may be communicated, and the idea of a perfect telegraph would be realised.

“Without experience it is impossible to say with what rapidity this electro-magnetic telegraph could be worked, but in all probability intelligence could be conveyed by such a medium as quickly as it is possible to write, or at least to print ; and apparatus could be constructed somewhat resembling the keys of an organ, by which the letters of the telegraph could be touched with the most perfect ease and regularity.

“It has been mentioned that the transmission of the electricity or galvanism could be discernible by various means well known. If any indication, however slight, is made, that is enough—all that is wanted being that it should be perceivable by the person placed to watch the telegraph.

“It has been assumed that the electric current is capable of transmission by means of a single impulse from Edinburgh to London. But it is not indispensable that so great a distance should be accomplished at once. Intermediate stations for supplying the telegraph with new galvanic influence could be resorted to, and its perfect efficiency still be preserved.\*

\* Manual retransmission, not automatic translation, is here meant.

“The best mode of troughing or protecting the metallic conductors, and separating them both from each other, and from the surrounding substances by which the electric or galvanic influence might be diverted, would of course require considerable scientific and mechanical skill ; but the object appears perfectly attainable. Insulating or non-conducting substances, as gumlac, sulphur, resin, baked wood, &c., are cheap, and the insulation might be accomplished in many ways. For example, by laying the wires, after coating them with some non-conducting substances, in layers betwixt thin slips of baked wood, similarly coated, the whole properly fastened together and coated externally. These slips might be perhaps ten yards long, and at the joinings precautions for the expansion and contraction of the wire, by the change of temperature, might be adopted. The whole might be enclosed in a strong oblong trough of wood, coated within and pitched without, and buried two or three feet under the turnpike road.

“The expense of making the telegraph proposed, is of course an important element in the consideration of its practicability and utility.

“The chief material necessary, *viz.*, copper wire, is by no means expensive. It is sold at 1s. 6d. per pound, of sixty yards in length. The cost of a wire from Edinburgh to London, say 400 miles, would thus be about 900*l.*—but say for solderings, &c.,

100*l.* additional ; or that each copper wire, laid from Edinburgh to London, would cost 1000*l.* sterling, and that the total expense for the wires necessary to indicate separately each letter of the alphabet, would be 25,000*l.* The purchase of so large a quantity would of course be made at a considerably less price ; but probably one or two additional wires might be needed, and the circuit of the electrical influence must be provided for by one or more return wires.

“The coating, separating, and troughing of the wires can be accomplished by low-priced materials, and the total expense of the whole work (except the price of the wires), allowing a large sum for incidental expenditure, has been roughly estimated at 75,000*l.* ; making a maximum expenditure of, say 100,000*l.*, for the completion of the telegraph. For a proportionately additional sum it might be extended to Glasgow.

“The average of the parliamentary estimates for railways is about 15,700*l.* per mile, so that the whole cost of the electro-magnetic telegraph proposed would only amount to as much as the construction of a railway of between six and seven miles in length. Were the details of this plan decided on by competent scientific and practical persons, the cost would be accurately estimated with unusually few sources of error. Here are no levels to adjust—no viaducts to erect—no morasses to cross—no property to purchase. Buried under the public road to the depth of two or three feet, the machine would be amply protected

against injury, as well as from any atmospheric influence. For change, or damage occasioned by changes in the road, it would be easy to provide. Damage by mischievous persons is quite unlikely, as is shown by the safety of water-pipes, gas-pipes, and railroads. But it would be quite easy to arrange a system for immediately detecting the seat of any damage, and its repair would be perfectly easy.

“As to the working of the telegraph, it is apprehended that even if the speed of writing were not attained, there could at least be no difficulty in indicating one letter per second. At this rate, a communication which would contain sixty-five words would occupy about five minutes. This is supposing the vowels to be all indicated. But abbreviations in this, and many other respects, would no doubt be contrived; and the number of words in the communication supposed, are greater than necessary for an ordinary banking or commercial letter, or for friendly inquiries and responses. Supposing, however, that each communication was to occupy five minutes, and to be charged five shillings—if the telegraph was worked twelve hours a day (that is, six hours from each end), it would produce a revenue of 36*l.* daily, or 10,800*l.* per annum, supposing there were to be 300 working days in the year. If, however, the plan is practicable, the public intelligence that would no doubt be transmitted by the telegraph, would be sufficient to keep it in operation night and day.



“No one can doubt that there would be a very great demand for the services of such a perfect telegraph as is here supposed capable of being constructed. In every department of commerce, in shipping, in banking, and all money transactions, in the communication of public and political intelligence, in the law, and in family and friendly intercourse, the utility of the telegraph would be immense. By coming at the same time to the two ends of the telegraph, parties might almost enjoy all the advantages of a personal interview, at a trifling expense. The consequence of such a machine being established, would be to bring, as it were, the cities of London and Edinburgh into the immediate neighbourhood of each other, and to produce transactions and communications of kinds not hitherto known or practised—communications which do not at present pass through Edinburgh or London would be brought to these points for the sake of rapid transmission—communications might be made to intermediate points, and public intelligence could be disseminated all along the line. Were the example followed all over the kingdom, it would create perhaps one of the greatest changes in human affairs, called into operation by the ingenuity of man.

“After the uses to which the power of steam and coal-gas has been so successfully and wonderfully applied, the telegraph now proposed may not be an unworthy follower in the march of discovery and improvement.

“The present sketch is submitted for the private consideration of a limited number of scientific and influential gentlemen, of whom a meeting will soon be convened, to give their opinion of the practicability and utility of the plan here generally developed.”

The following is a description of the apparatus as given by the author at p. 19 of his pamphlet :—

“The model is contained in a mahogany case, or frame, 6 feet long, 2 feet wide, and 3½ feet high.

FIG. 30.

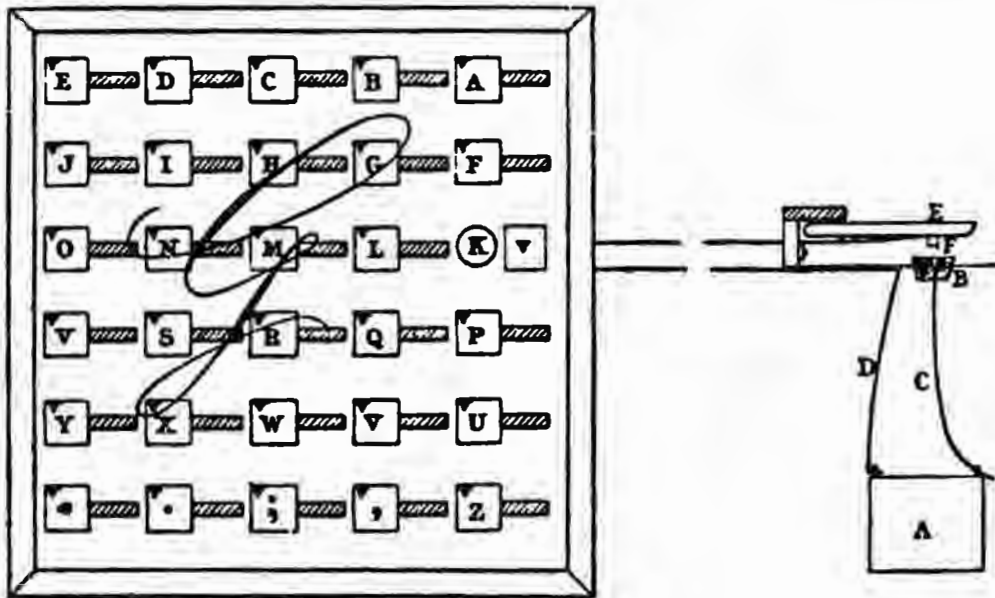

“The end of the case, intended to face the north, is composed of a wooden board or tablet coloured black, with the twenty-six letters of the alphabet, a comma, a semicolon, a full point, and an asterisk, shown on white enamel, at equal distances, in six rows or tiers. The tablet is protected by a sheet of plate glass, and

the top or lid of the case is also of glass, for more easy inspection of the interior.

“Behind the tablet are placed (also in six rows or tiers) thirty steel magnets, about two inches long, poised on their centres, so as to admit of their assuming their natural position in the magnetic meridian, and thus having their north poles pointed to the back of the tablet.\* On the north pole of each of the thirty magnets a small piece of brass wire is fixed, protruding through a slit or aperture in the tablet; and from the point of this brass wire a thin piece of brass of about one-half inch square, coloured black outside, is suspended.

“Each of these thirty pieces of brass, when the needles are in their natural direction of north and south, conceal or veil one of the letters or points marked on the tablet; and in this position the observer of the tablet perceives nothing but one uniform black surface.

“Each of the magnets is poised within a coil of several convolutions of copper wire, and a galvanometer is thus formed.

“At the other, or south end of the model, is a horizontal line of thirty wooden keys, resembling the keys of a pianoforte, and on these keys are marked the twenty-six letters of the alphabet, a comma, a semicolon, a full point, and asterisk, in the same

\* Many writers, as Moigno and Shaffner, describe and illustrate these needles as suspended *vertically*, which is a mistake.

manner as on the tablet. Thirty insulated copper wires traverse the model from the keys to the galvanometers, with both of which they are connected.

“Each galvanometer is also connected by an insulated wire, about three inches in length, with a transverse copper rod, extending from one side of the model to the other. There are six such transverse rods, placed horizontally and at right angles with the six rows or tiers of galvanometers. These copper rods are connected by wires with each other—and a thick copper wire traverses the model from the undermost rod to the south end of the model, and is there connected with the copper plate or positive pole of a small galvanic battery.

“In a small trough or reservoir, extending under the whole length of the line of keys, a small quantity of mercury is deposited, and the zinc plate or negative pole of the galvanic battery is connected by a wire with the mercury in the trough.

“It must be here noticed that the two poles of the galvanic battery are thus connected together by the wires and metallic conductors above described, *except in the space that intervenes between the keys and the trough of mercury placed beneath them.*

“It has, therefore, in the next place to be remarked, that thirty pendant platinum wires are attached to the under part of the thirty keys of the model, and that when any key is pressed down with the finger, the pendant platinum wire is immersed in the mercury,

and the galvanic circuit, by means of metallic conductors, between the two poles (copper and zinc) of the battery completed.

*“ The instantaneous effect of the galvanic circuit being so completed is to cause one of the magnets to deflect towards the west, carrying the small brass veil along with it, and thereby exhibiting on the tablet the same letter of the alphabet or point that is marked on the key pressed down.*

“ When the finger is taken off the key it rises, by means of a spring underneath, to its former position on a level with the other keys ; and the pendant platinum wire ceasing to be dipped in the mercury, the galvanic circuit is again broken, and the magnet returns to its natural position, and veils the letter that was shown on the tablet.

“ Hence it follows, that by simply pressing down with the finger any of the keys (precisely in the same manner as the keys of a pianoforte are touched), the same letter that is marked on the key is shown on the tablet for a sufficient length of time to allow it to be observed by any person watching the motions of the veils on the tablet ; and words are thus communicated in rapid succession from the one terminus of the telegraph to the other.

“ When, in the course of a communication, it is wished to indicate a comma, semicolon, or full period, these will be disclosed on the tablet on the corresponding key being pressed down ; and in order to

indicate that the spelling of a word is finished, the key marked with the *asterisk* may be pressed down, and the asterisk being at the same instant exhibited on the tablet, will show the observer that the word is completed, and that a new one is about to be spelled.

“In order either to send or receive a communication by a telegraph of the simple construction proposed, no greater learning would be required than is necessary in reading a common book ; and the rapidity with which a communication could be made, would be as great as that with which most persons are able to write, or as a compositor is able to set up types.

“In telegraphing between distant points, the connecting wires would be made to traverse the intermediate space through a tube of wood, or some other material that would protect the wires from external injury ; and the wires would of course be separated from each other by laying them in separate grooves in the tube, or by coating them with some non-conducting substance. The diameter of the tube might be very small ; and in order to protect the wires from any atmospheric influence, and the tube itself from violence, it would be best placed under ground.

“Following out the scientific principles that have been explained, and taking advantage of the mechanical contrivances illustrated by the model now exhibited,

it appears perfectly practicable to construct an electro-magnetic telegraph surpassing all other kinds of telegraphs in respect to the rapidity, facility, and certainty with which every species of communication can be made between points, however distant."

Having perfected his plans, Alexander submitted them to the Government in the following letter which he addressed to Lord John Russell, Home Secretary, on June 12, 1837, the date, by the way, of Cooke and Wheatstone's first patent :—

"Edinburgh, 19 Windsor Street,  
"12th June, 1837.

"My Lord,—I have the honour to enclose for your Lordship's consideration a plan for an electro-magnetic telegraph between Edinburgh and London, and capable of being adopted all over the kingdom with the most important national advantages.

"I have had the honour of submitting the plan to some of the most eminent scientific and influential persons here, and have met with the most flattering approbation from them.

"In order to test the practicability of the plan, experiments have, by the obliging permission of Dr. Hope, the professor of chemistry, been made in his class-room in our University, by his very able practical demonstrator Mr. Kemp, both upon a small and pretty extensive scale—a metallic conductor of about four miles in circuit having been operated upon both

by mechanical electricity and by galvanism. These experiments have been performed in the presence of Professor Hope himself, and also of the Lord Provost; the Solicitor-General; the Master of the Merchant Company; Sir Charles Gordon, the secretary of the Highland Society; Sir John Hall; Professor Jameson; Professor Traill; Mr. Patrick Robertson; Mr. George Monro; Mr. Hamilton, architect; and other scientific and literary gentlemen, and have proved most satisfactory. A plate of copper and a plate of zinc (about the size of a crown-piece each) immersed in a little acid water, were found sufficient to move an ordinary magnetic needle at the termination of a copper wire of four miles in length, notwithstanding numerous joinings and sinuosities in the conductor.

“Should the telegraph projected ultimately prove capable of the general utility and application contemplated, I humbly think, from its affinity to the Post Office Department, it may prove worthy of the attention of Government, in place of being left to individual enterprise.

“In either case, I venture to hope that sufficient has been already demonstrated both of its practicability, and national importance and utility, to excuse my bringing the plan under your Lordship’s notice, and to request your distinguished patronage.

“It has been suggested to me that the fund, amounting to upwards of 6000*l.* per annum, ad-



ministered, subject to the orders of the Lords of the Treasury, by the trustees for the encouragement of arts and manufactures in Scotland, could not be better applied to the extent of a few hundred pounds than by defraying the cost of additional experiments under the superintendence of the gentlemen I have named, or such others as may be selected, upon a still larger scale than it can be expected that individuals should supply for a national object.

“If upon an extent of 50 or 100 miles of metallic conductors, the same instantaneous and perfect indication of the passage of the electric or galvanic fluid is found, as has been in the case of our recent experiments at the University, the triumph of the scheme would be complete.

“May I request the favour of your Lordship's views.

“The Solicitor-General transmitted a print of the plan about a week ago to the Lord Advocate, and I have since made a communication to his Lordship (to whom I have the honour of being known) on the subject.

“I have the honour, &c.,

“W. ALEXANDER.”

The reply was as brief and as little satisfactory as those vouchsafed to Wedgwood (1814), Ronalds (1816), Porter (1825), and “*Corpusculum*” (1832). It ran as follows:—

“Whitehall, 15th June, 1837.

“Sir,—I am directed by Lord John Russell to acknowledge the receipt of your letter of the 12th instant, enclosing a Plan for an Electro-Magnetic Telegraph.

“I am, Sir,

“Your obedient servant,

“S. M. PHILLIPS.”

In December 1837, Alexander memorialised the Lords of the Treasury on the subject, but with no better fortune. The memorial set forth

“That the attention of your memorialist has been for some time past directed towards effecting an instantaneous telegraphic communication between London and Edinburgh by means of electro-magnetism; and he now respectfully submits to your Lordships a print of the plan respecting this object, that was circulated by him last summer for the consideration of certain scientific and official gentlemen in Scotland.

“The result of the investigation instituted was, that the heads of the public bodies in Edinburgh, and the most scientific persons resident in that city, concurred in the accompanying testimonials of their belief of the success of the plan, and an expression of their readiness to act as a committee to direct and superintend experiments further to test the practicability of the proposed undertaking.

“That in order further to illustrate your memorialist's

views, he caused to be prepared a model of the projected telegraph, and exhibited the same to the first meeting of the Society of Arts in Edinburgh, and refers to a copy of the *Scotsman* newspaper of the 18th November, 1837, as containing a description of the model, and its powers in effecting instantaneous telegraphic communication between distant places.

“That your memorialist, from a strong conviction of the vast national importance attached to the completion of an instantaneous telegraphic communication between all parts of the kingdom, at a moderate expense, feels himself warranted in laying the above-mentioned documents before your Lordships, and in praying that such provision may be made by a grant of money, reference to scientific persons or otherwise, as to your Lordships may seem meet.

“That the model above referred to has been conveyed from Edinburgh to London; and your memorialist will have much satisfaction in exhibiting it in complete operation to your Lordships, and to give any further explanations that may be thought proper.

“All which is respectfully submitted by

“W. ALEXANDER.”

The following is the paragraph in the *Scotsman* referred to in the memorial :—

“The telegraph thus constructed operates with

ease and accuracy, as many gentlemen can witness. The term model, which we have employed, is in some respects a misnomer. It is the actual machine, with all its essential parts, and merely circumscribed as to *length*, by the necessity of keeping it in a room of limited dimensions. While many are laying claim to the invention, to Mr. Alexander belongs the honour of first following out the principle into all its details, meeting every difficulty, completing a definite plan, and showing it in operation. About twenty gentlemen, including some of the most eminent men of science in Edinburgh, have subscribed a memorial, stating their high opinion of the merits of the invention, and expressing their readiness to act as a committee for conducting experiments on a greater scale, in order fully to test its practicability. This ought to be a public concern. A machine which would repeat in Edinburgh words spoken in London three or four minutes after they were uttered, and continue the communication for any length of time, by night or by day, and with the rapidity which has been described—such a machine reveals a new power whose stupendous effects upon society no effort of the most vigorous imagination can anticipate.”

Alexander opposed the application of Cooke and Wheatstone for a Scotch patent in 1837, but ultimately withdrew his opposition under circumstances which are thus described in a letter of Miss

Wheatley (now Lady Cooke), dated December 2, 1837: \*—

“I have the pleasure to tell you that the Scotch patent is now free from all opposition, and will be obtained immediately. William had an interview with Mr. Alexander on Thursday at the Lord Advocate's (of Scotland) office, and he agreed to accompany the Judge and Lord Lansdowne to see some experiments yesterday at Euston Square terminus. These proved so satisfactory that Alexander at once acknowledged the superiority of William's and Mr. Wheatstone's plans, and gave up his own. This was an agreeable way of arranging the matter, and William was pleased with Alexander's manner of yielding the point; though, of course, he saw he had no chance of succeeding.”

Alexander did not, however, cease to advertise his own invention. Wheatstone, writing to Cooke, December 15, 1837, says:—“Alexander continues to make a great noise about his invention. A few days ago he took it to Kensington Palace for the inspection of the Duke of Sussex; and last night he was at the Royal Society.” Early in 1838 he placed it on exhibition at the Royal Gallery of Practical

\* Extracted by kind permission of Mr. Latimer Clark. See also Cooke's evidence in *The Electric Telegraph Company versus Nott and others*, Chancery Proceedings, p. 49. A printed copy of the evidence and affidavits in this celebrated case is preserved in Mr. Latimer Clark's magnificent collection of books on electricity and magnetism—a collection which rivals and, in some respects, excels that of the late Sir Francis Ronalds.

Science, Adelaide Street, Strand ;\* at the Polytechnic Institution, London, in 1839 ; at the Glasgow meeting of the British Association, in 1840 ; and finally at the Great Exhibition (Hyde Park), in 1851.

In answer to some inquiries of ours, Mr. George P. Johnston, the well-known bookseller, of 21, Hanover Street, Edinburgh, has kindly sent us the following letter :—

“Edinburgh, 5th May, 1883.

“Dear Sir,—I fear you will think I have forgotten about your queries as to Mr. Alexander, but the delay has been caused by the difficulty of finding people in, &c.

“I can obtain no information regarding his family whatever, and he seems to have passed out of the remembrance of Edinburgh people. All I can gather is that he was considered by some ‘a clever man always inventing,’ by others as ‘half-crazed on the subject of inventions.’ I am sure he is the same W. Alexander who is author of several treatises on Scotch Bankruptcy Acts, &c., published between 1847 and 1859. It is curious that one philosophical instrument maker here—the only one old enough to have known him—never heard of him.

“I am, yours respectfully,

“GEO. P. JOHNSTON.

“To J. J. Fahie, Esq.”

\* See p. 381, *ante*. He also brought it before the Society of Arts, which, however, decided that it was not new, and, on that account, unworthy of attention.—Letter, Wheatstone to Cooke, of 24th March, 1838.

Dr. Edward Sang, Secretary of the Royal Scottish Society of Arts, informs us that Alexander proposed a bridge over the Forth at Inch-Garvie, just where one is now about to be built.

Alexander's death is mentioned in the *Transactions of the Royal Society of Edinburgh* as having occurred during the session of 1859-60; but there is no obituary notice.

#### 1837-8.—*Mungo Ponton's Telegraph.*

On the 15th November, 1837, a working model of the apparatus last described was exhibited at the Society of Arts, Edinburgh, and excited the keenest interest amongst all the members present. One of these, the late Mr. Mungo Ponton, was so impressed with the subject that he set about at once to devise a telegraph of his own, which should be free from the imperfections with which he saw that Alexander's was hampered; and so rapidly did execution follow upon the heels of design, that in five days, *i. e.*, on the 20th November, 1837, he forwarded to the Society a "Model and Description of an Improved Electric Telegraph." The paper was read at the meeting of the 10th January, 1838; and again, on the 20th June following, a supplement was presented, together with a model of the telegraph in an improved form.\*

\* Both these documents are now before us, having been lately discovered after a long search which was kindly made for us by Dr. George Macdonald, of Edinburgh. The model was for many years in the museum of the Society, but on a change of offices it was put away in a damp cellar, where it soon fell to pieces.

In the first communication Ponton begins by saying :  
“ When, on a former evening, Mr. Alexander’s electric telegraph was exhibited, I took occasion to point out one or two defects under which it appeared to me to labour. These were—1st, the weak and vacillating character of the force employed to discover the letters ; 2nd, the great size of the reading-board ; and 3rd, the very unnecessary multiplication of the lines of wire. Had Mr. Alexander had a just claim to the original invention of an electric telegraph, I should have considered it only fair to have pointed out to him the remedies which had occurred to me for the removal of those defects ; but as I am led to understand that his claim to originality extends no further than to the mode of constructing the telegraph, I felt myself at liberty to follow out my own ideas.

“ The objects I have had in view in the construction of the models now submitted to the Society are —1st, to show how a powerful and decided force may be developed at the reading end of the telegraph ; 2nd, how the reading surface may be reduced within very narrow limits ; 3rd, how the quantity of motion required for the display of the characters may be made very minute, only a quarter of an inch ; 4th, how that motion may be rendered independent of the swing of the needle ; and 5th, how with only eight lines of wire we may exhibit all the letters of the alphabet, all the figures, a variety of points and signs, and a considerable number of combinations of letters.



“The first model to which I would call attention is that which shows the method of developing a powerful and steady force at the reading end of the telegraph. This consists of a dipping needle, delicately poised, and furnished with a galvanometer coil. From either side of the centre of the needle is suspended a small slip of wood, from which project downwards the four ends of two bent wires, which dip into mercury cups. The mercury in the cups is connected with the opposite ends of the wires of a pair of common electro-magnets, whose poles are opposed to each other. When one end of the dipping needle is down, and the wires on one side touching the mercury in the cup, the effect is to make the two electro-magnets attract each other. When the other end of the needle is sent down by means of the electric current passing through the galvanometer coil, the effect is to make the two electro-magnets repel each other. In this manner a very considerable and a perfectly steady force is produced, which may be employed for the raising and depressing of levers for the display of the characters.

“Although I should consider this a very decided improvement, yet it is not necessary for the other improvements which I have suggested, and accordingly I have not used it in the construction of the model telegraph now before the Society. To that model I would now direct attention.

“It will be seen to contain eight galvanometers,

having their needles suspended vertically like a dipping needle. These are placed in two sets of four, piled one above another, each lower needle projecting beyond the one immediately above it. To the end of each needle is attached a fine thread, which is stretched upwards and attached to the bottom of a card. There are eight of these cards placed one before another. They are suspended by threads to the end of eight levers placed one above another. When the needles are in their natural position they hold down the cards against two bars which are placed so as to support them. When the needles are affected by the electric current passing through their coils, they swing upwards, and slacken the thread by which the cards are held down, and the cards are then pulled upwards by the levers attached to their upper ends. Their motion, however, is checked after they have moved a quarter of an inch, by a piece of wood placed for that purpose. Thus the motion of the cards is rendered in a great measure independent of the swing of the needle.

“The ends of the galvanometer wires are passed onwards to a key-board at the working end of the telegraph. This key-board contains eight keys, a pair being attached to each wire, the one passing a negative, the other a positive electric influence through the line of wire. The needles are so adjusted that the one is affected by the positive, the other by the

negative current, so that each wire works a pair of needles.

“Behind the cards at the reading end of the telegraph is a permanent back, with characters upon it, disposed in four columns and nine lines. The two backmost cards have also characters upon them, disposed in two columns and nine lines. There are thus in all eight columns and nine lines, or seventy-two distinct signals. The cards have a variety of openings cut in them for displaying the characters, so arranged that only one character is displayed at a time. The four hinder cards are cut so as to display in succession the eight columns, and the four front ones so as to display eight of the nine lines, also in succession, the uppermost line being seen when the four front cards are at rest.

“Thus when any one of the four hinder cards is touched alone, it displays a character on the first line. The outermost displays the character situated on the extreme left column of the permanent back, and the innermost that situated on the extreme right. When the first and third keys are touched, the characters on the left column of the backmost card are discovered, while the first and fourth display those in the right-hand column. When the second and third keys are touched, those in the left-hand column of the second backmost card are displayed; the second and fourth display those on the right. It will be thus seen how the whole eight columns are displayed. The inner-

most of the four front cards, corresponding to No. 5 of the keys, when raised alone, uncovers the second line; the next the third, the next the fourth, and the outermost the fifth. When the fifth and seventh keys are touched, the sixth line is displayed; the fifth and eighth display the seventh line. The sixth and seventh keys display the eighth line; the sixth and eighth display the ninth.

“From this explanation it is easy to see how any one of the seventy-two signals can be made to appear.

“The following is the arrangement adopted in the present model :—

Signs.	Keys.	Signs.	Keys.	Signs.	Keys.
A . . . . .	1	I . . . . .	3	Q . . . . .	3·5
B . . . . .	2·7	J . . . . .	1·3·6	R . . . . .	4·8
C . . . . .	4·5	K . . . . .	1·5	S . . . . .	1·6
D . . . . .	4·6	L . . . . .	3·8	T . . . . .	3·6
E . . . . .	2	M . . . . .	1·8	U . . . . .	1·3
F . . . . .	3·7	N . . . . .	2·8	V . . . . .	4·7
G . . . . .	2·5	O . . . . .	4	W . . . . .	1·4
H . . . . .	2·4	P . . . . .	1·7	X . . . . .	1·4·6
Y . . . . .	2·3	Z . . . . .	2·6		

The remaining signals are dedicated to the exhibition of figures, points, arithmetical signs, and combinations of letters; but it is unnecessary to particularise the arrangement. Of course they are all produced by touching either three or four keys together.

“It will be observed that any one of the four front cards may be touched alone without producing any signal. This might be taken advantage of to extend the number of signals to 120, by employing the

needles which move the front cards to shift the permanent back."

In the improved model of June 20, 1838, Ponton had so contrived matters as to be able to reduce the number of line wires to four, by the various combinations of which into metallic circuits as in Cooke and Wheatstone's five-needle telegraph, and by using positive and negative currents, he was able to show forty-eight different signals. The work of the electric currents was also reduced to a minimum, slight deviations of the needles being all that was necessary.

Proceeding on the principle that in all correct telegraphing every signal made from one end should be repeated back from the other, he adopted the plan of exhibiting the signals, not in their direct transmission, but on their repetition, and by an arrangement which allowed the signal-indicating apparatus to be worked, not by the needles as before, but by the hand of the receiver in the act of repetition.

The galvanometer needles were eight in number (two in the circuit of each wire), and bore marks corresponding to keys, which, on being depressed, sent positive or negative currents into their respective line wires, and, at the same time, uncovered the letters, figures, or signs with which they were in train. Whenever, therefore, any of the needles were deflected, the receiver had only to depress the corresponding keys, by which act he repeated the signal back to the sending station, and uncovered the letter,

figure, or sign which that signal was intended to express.\*

The following table shows all these signs and the numbers of the keys which entered into their formation :—

Signs.	Keys.	Signs.	Keys.	Signs.	Keys.
A . . . . .	1'4	I . . . . .	4'5	Q . . . . .	1'4'7
B . . . . .	1'6	J . . . . .	4'7	R . . . . .	1'4'8
C . . . . .	1'8	K . . . . .	5'8	S . . . . .	1'6'8
D . . . . .	2'3	L . . . . .	6'7	T . . . . .	2'3'5
E . . . . .	2'5	M . . . . .	1'3'6	U . . . . .	2'3'6
F . . . . .	2'7	N . . . . .	1'3'8	V . . . . .	2'3'7
G . . . . .	3'6	O . . . . .	1'4'5	W . . . . .	2'3'8
H . . . . .	3'8	P . . . . .	1'4'6	X . . . . .	2'4'5
	Y . . . . .	2'4'7	Z . . . . .	2'5'7	
,	2'5'8	1	1'3'5'8	8 . . . . .	2'3'5'7
;	2'6'7	2 . . . . .	1'3'6'7	9 . . . . .	2'3'5'8
.	3'5'8	3 . . . . .	1'3'6'8	o . . . . .	2'3'6'7
&	3'6'7	4 . . . . .	1'4'5'7	+	2'3'6'8
Sig.	3'6'8	5 . . . . .	1'4'5'8	- . . . . .	2'4'5'7
E R.	4'5'7	6 . . . . .	1'4'6'7	x . . . . .	2'4'5'8
R E.	4'5'8	7 . . . . .	1'4'6'8	+	2'4'6'7
E N D.	4'6'7				

Ponton added an alarum which was a very simple affair, and recalls a somewhat similar one of Edward Davy described on p. 357. An extra galvanometer was placed in the circuit of one of the line wires, and across its needle was placed a fine platinum wire,

\* With a little practice this would have been found to be a work of supererogation, for the operators would soon have come to know the values of the deflections, without the need of reproducing them in black and white. Again, it would soon have been found that four galvanometers would suffice; and thus the system would resolve itself into a four-needle telegraph.

which, normally, rested against a lucifer or other quick match. Above the match was a thread holding back the hammer of a bell or the detent of an alarum. To sound the alarum the proper keys were held down for a few seconds, the needle of the galvanometer was deflected and carried the piece of platinum wire into the flame of a spirit lamp; then on reversing the direction of the current in the line the red-hot wire was suddenly brought in contact with the match, which, igniting, burnt the string above it and so released the hammer of the bell or the detent of the alarum.\*

On the report of a committee an honorary silver medal was awarded in December 1838 to Mr. Ponton "for the ingenuity of his plans as manifested in the working model which had been presented to the Society."

\* A supply of matches and strings would of course be necessary. In the ordinary course of signalling, the platinum wire would often be in the flame of the lamp, but never sufficiently long to be heated to the point of igniting the match; so that, as Ponton points out, there would be small risk of unseasonable alarums. Ponton also suggested an alarum by the direct action of a rather heavy galvanometer needle striking against a bell when deflected by the current.

CHAPTER XVII.

TELEGRAPHS BASED ON ELECTRO-MAGNETISM AND  
MAGNETO-ELECTRICITY (*continued*).

1837.—“*Corpusculum's*” *Telegraph*.

WE copy the following letter from the *Mechanics' Magazine*, for December 30, 1837, p. 219—a most valuable work for all engaged in scientific research, and to which we gratefully acknowledge ourselves indebted :—

“Sir,—I first met with an account of Alexander's telegraph last night in the *Mechanics' Magazine*, and a very important improvement suggested itself, which will render fifteen of the thirty-one wires unnecessary. I see no reason why each of fifteen wires should not represent two letters, thus ; let each of the letter screens affixed to the movable magnets be wide enough to cover two letters. Then the positive end of the galvanic battery being connected with the conducting wire, by a touch of the keys, the magnet and screen will move in one direction and discover one letter. The negative end of the battery being then connected with the same wire, the magnet will move in the contrary direction and discover the other letter. There must of course be something fixed to prevent the magnet going so far in either direction as



to discover both letters. The returning wire connected with all the other thirty (? fifteen), must, of course, have its connection with the battery poles reversed, at the same time as the lettered wire.

“ Not having seen a model of the instrument, I am in doubt whether the magnet would not, on returning to its stationary position, want a contrivance to prevent its oscillation ; I have, therefore, devised the following plan which would perhaps be the best of the two :—Let each wire act upon two magnets and screens, one magnet and screen moving in one direction, but prevented from moving in the other as now. The current of electricity if reversed, would, on account of this prevention, not move *this* magnet and screen in the opposite direction, but it would the *other* magnet and screen, having a similar stop or prevention, but placed on the other side of the pole.

“ It seems many persons have formed designs for telegraphs, I, too, formed mine, and prepared a specification of it five years ago, and that included the plan of making one wire only serve for the returning wire for all the rest, as in Alexander’s telegraph ; *but even that might, I think, be dispensed with where a good discharging train, as gas or water, pipes, at each end of the telegraph could be obtained.* I wrote to the Admiralty at the time I mention on the subject of my invention, but facilitating commercial correspondence it seems was too contemptible a subject for state philanthropy.

“My telegraph was designed to print off its own communications (and I think might be made to convey hundreds in a minute) by means of a machine I invented for rapidly writing in the common printing characters, and which I wished to get some one to join me in perfecting and patenting, but was unsuccessful, as I have been in two or three other instances in which others are now reaping the advantages which I should have done myself, but for that infamous plundering incubus upon talent, the English Patent Laws. I think the following method might serve to secure the poor man's patent without interfering with the legal right of plunder. Let him have the liberty of filing a specification (? sealed or open), which should have the effect of preventing every other person, and also himself, from deriving any benefit from his invention, till the plunderers by legal authority should have their ‘pound of flesh.’

“This preliminary specification should enable the inventor to take a patent for anything coming fairly within its scope and spirit. It would enable him to enter into a contract on fair terms with any person able to bear the expense of a patent, which he cannot now do without risk of being victimised, as I have lately had reason to know to my cost. There is also a valuable protection that I think might be extended to scientific, as it is to literary, inventions. A man's play cannot be exhibited to others without his sanction. There is just as good reason why a working model of either a

useful or pleasing piece of mechanism should be protected from piracy. I may mention as an instance (of which there are many others), that I am constructing a model twenty inches broad by twenty-four long and twenty-four high, for a machine to produce light by a succession of electric sparks. I have completed one element which is, of itself, all but sufficient to read by, and when the other elements are complete, it will be certainly capable of being thirty-two times as powerful, and not improbably sixty or one hundred times. A larger one which I had commenced (but which I fear will be too expensive for me to complete, in the present unprotected state of science) is eight feet, by four feet eight inches high, and I calculate it would produce a million, and not improbably many millions, of sparks of various colours in a minute, and would give 100,000 moderate shocks, or by (combination) 4000 or 5000 far too intense for endurance, in the same short period.

“ This would doubtless form a very excellent subject for exhibition ; but as any blockhead may imitate, I have given up the thought, at least for the present.

“ CORPUSCULUM.

“ December 8, 1837.”

We have copied this letter *in extenso*, with all its ambiguities, for two reasons, 1st, because it is intrinsically interesting and valuable, and 2nd, in the hope

that our doing so will afford a clue to some of our readers who may wish to discover the true name of the writer. The points of interest in this letter are:—

(1) The suggestion of a telegraph like Davy's.

(2) The suggestion of the earth circuit seven months before Steinheil's *accidental* discovery of it, and exactly as we use it to-day.

(3) The construction of a Roman type printing telegraph in 1832.

(4) The suggestion of a patent law which was subsequently passed, and of a law applicable to instruments, as copyright is to literary productions.

(5) A system of electric lighting—the light-giving part to consist apparently of one or more vacuum tubes, guardedly called “elements,” no doubt, with the object of misleading “pirates and blockheads.”

#### 1837.—*Magrini's Telegraph.*

The proposal that we have now to notice is one of great merit, and resembles in some respects Cooke and Wheatstone's five-needle, or *Hatchment*, telegraph of 1837. It is the invention of Professor Luigi Magrini, of Venice, and is described by him, at length, in a *brochure*, which he published, at Venice, in 1838, entitled *Telegrafo Elettro-Magnetico, Praticabile a Grandi Distanze*. From an Appendix on pp. 85–6, it appears that the first published account of this telegraph is that contained in the *Gazzetta Privilegiata di*

*Venezia*, No. 189, of 23rd August, 1837 ;\* but, as far as we can discover, it was never tried on any extensive scale. Had this been done, there can be no doubt that it would have succeeded as well as the English one, and we should have had the curious result of seeing the simultaneous and independent establishment in Italy and in England of electric telegraphs, which are not only based on the same principles, but, in some respects, are almost identical.

The signal apparatus consisted of a horizontal table, one metre long, and sixty centimetres broad, into which fitted three galvanometers as shown in the Fig. 31. By means of two batteries of different strengths, and a commutator, each needle was susceptible of four movements, one weak and one strong to the right, and one weak and one strong to the left. These four positions indicated for each needle a different letter which was suitably inscribed on the board, or table. Thus, the letters appertaining to the first galvanometer were A, B, C, D ; those of the second, I, L, M, N ; and those of the third, S, T, U, V.

In order to indicate all the other letters, the needles were employed, two and two at a time ; F, for example, corresponded to *weak*, right-handed deflections of needles 1 and 2 ; H, to *strong* deflections of the same two needles, and in the same direction ; O, to weak,

\* In the *Annales Télégraphiques*, for March–April 1882, p. 140, it is said to date back to 1832 ; but this is probably a misprint.

left-handed deflections of the second and third needles ; R, to strong deflections of the same needles, but in the other, or right-handed direction ; and so on for the rest.

FIG. 31.

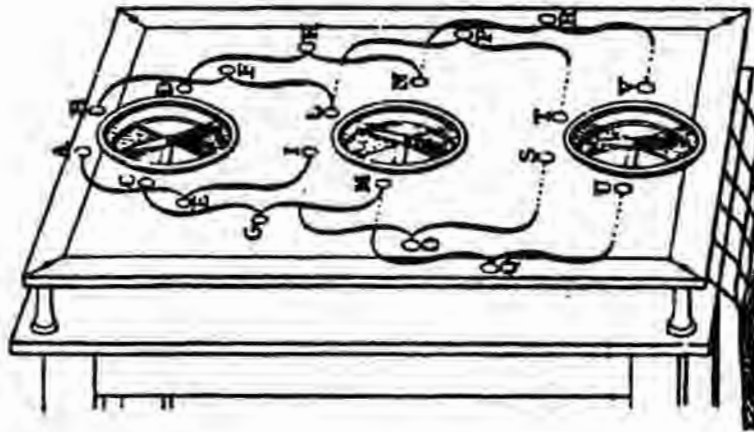

Magrini employed six line wires, forming three metallic circuits. At the sending station these dipped into troughs of mercury placed on a table, and a little above which was laid the commutating board on short supports. This board, which for clearness sake is shown in the Fig. 32, in a raised, or vertical, position, carried, underneath, twenty-four glass rods, in three rows of eight rods each. To the ends of each rod were attached elastic strips of brass, terminating in projecting pins of the same material, which could be pushed downwards (by means of a handle affixed to the centre of the rod and projecting through the top face of the board) so as to dip into the mercury troughs. The other ends of the elastic strips were permanently connected, the one with the positive,

and the other with the negative pole of one or other of the batteries E, and E'. Taking, for example, the first row of keys, or rods, on the left of the figure, which, we will suppose, was connected to the first

FIG. 32.

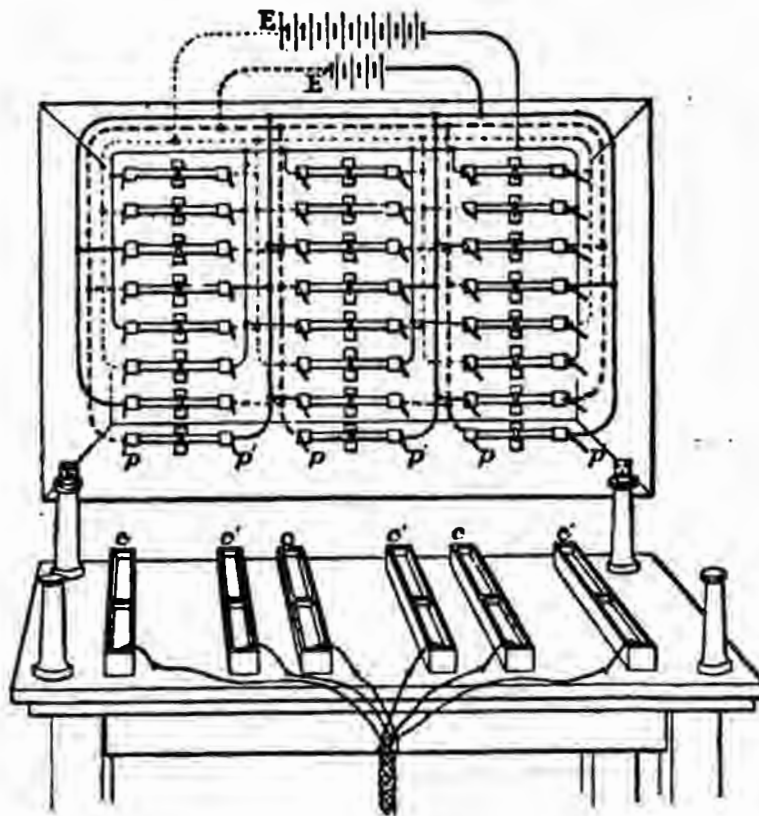

galvanometer at the distant station, then the first rod, at the top, was in connection with the poles of the strong battery ; the second rod was connected to the same battery, but in the reverse way to the first ; the third and fourth rods were connected to the weak battery in the same manner that the first and second were to the strong. The remaining four rods were

connected, rod for rod, like the last, that is to say, the fifth was connected to the same battery as the first, and in the same manner, the sixth like the second, and so on.

Whenever, then, the first rod was depressed, a current from the strong battery E, flowed out to line, and circulating through the coils of the first galvanometer, produced a strong deflection of the needle (say, to the left), and so pointed to the letter C. Depressing the second rod produced a strong deflection of the same needle to the right, and so indicated D; and so on for all the rest. With regard to the last four rods of each row they were used in pairs, one from each row; thus, when the fifth rods in the first and second rows were depressed, the needles of the first and second galvanometers were strongly deflected to the left, and indicated the letter G; while depressing the last rods of the second and third rows produced feeble deflections to the right of the second and third galvanometers, and indicated P.

It is easy to see that all these combinations could be obtained by making use of the first four rods of each row, but it was no doubt in order to avoid all chance of confusion that the inventor introduced special ones for this purpose.

Magrini added an alarum whose construction will be seen from the accompanying Fig. 33; the bar *m, o, n*, was so balanced that in its normal state its hammer *m*, rested against the bell. When it was required to



attract attention a current was set up in the electromagnet  $a, b, c$ , which brought down the soft iron armature  $F, G$ ; then by means of a pole-reversing arrangement  $Q, S$ , the direction of the current in

FIG. 33.

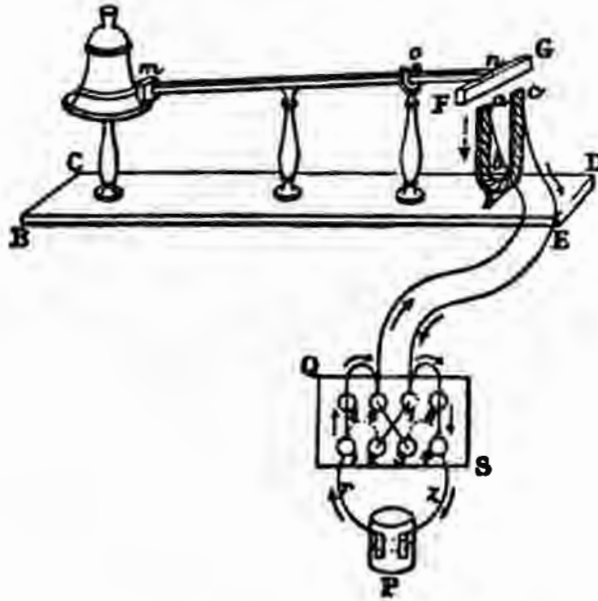

$a, b, c$ , was altered. Owing to the residual magnetism in  $F, G$ , the first effect of this inversion of current was to repel the armature, then immediately after to attract it afresh. At each reversal, therefore, of the current the hammer  $m$ , clicked against the bell and produced a tinkling sound.

#### 1837.—*Stratingh's Telegraphs.*

These aim no higher than to be lecture-room demonstrations of the possibility of an electric telegraph, and coming as they do at a time when not

only the *possibility*, but the *practicability* of this mode of communication was completely established, they would not deserve notice, were it not that they contain the suggestion of a contrivance which, we believe, to be of great practical utility in the construction of relays, and electro-magnets generally, and which, in this conviction, we utilised in our patent of February 3, 1876.\* On p. 3 of our Provisional Specification we say:—

“I will now describe the second part of the invention, which relates to improvements whereby the ordinary unpolarised relay, or electro-magnet, is rendered susceptible of great sensibility both for duplex and for single transmission. This is done for duplex by so utilising the local current, which the working of the relay brings into play at certain times, *that the armature, at these times, is itself an electro-magnet and opposes the attraction subsisting between its poles and those of the coils to the pulling force of the spring, so that, if need be, the magnetism of the coils has only to overcome the inertia of the lever, and not the force of the spring as well*; and for single working by making the counteracting springs parts of the local battery circuits and placing within them cylindrical bar-magnets or bars of soft iron.”

As will presently be seen (p. 490), the words that

\* No. 433. “Improvements in Electric Telegraphs, comprising an Improved System of Duplex Working, and an Improved Relay or Electro-Magnet, the principle of which may also be used in any Instrument or Contrivance where Relays or Electro-Magnets with Counteracting Springs are employed.”

we have italicised in the above extract are but the (of course unconscious) realisation of a suggestion made by Professor Stratingh nearly forty years before.

For the following account of Stratingh's telegraphs we are indebted to Mr. J. M. Collette, engineer of the Netherlands telegraphs.

"To Mr. J. J. Fahie, London.

"The Hague, April 28, 1883.

"Sir,—In reply to your letter of 17th instant, I have the honour to inform you that the late Mr. Stratingh, professor in the University of Groninque, published his article, "Iets over eenen Electro-Magnetischen Klokken-Telegraaf" (On an Electro-Magnetic Acoustic Telegraph), in the *Journal for the Encouragement of Industry*,\* for 1838.

"I send you a copy of the woodcut, Fig. 34, which accompanied the description of his apparatus. The latter consisted of two electro-magnets of the horse-shoe form, two levers, each having at one end an armature, and at the other a small hammer, and two bells, or gongs, of different tones. It is evident that when a current passed, for example, through the coil *i*, the armature *e*, would be attracted, and the hammer attached to the other end of the lever would descend and strike the bell *h*. To prevent the *sticking* of the armature it was provided on its under surface with a thin plate of ivory. The ordinary clockwork alarum *o*, *o'*, *o''*, *o'''*, was intended to warn the attendant of the

\* *Tydschrift ter bevordering van Nyverheid*, vol. v. part 2.

coming of a despatch. The armature *e*, in ascending released the detent *q*, and so set the wheel work in motion.

FIG. 34.

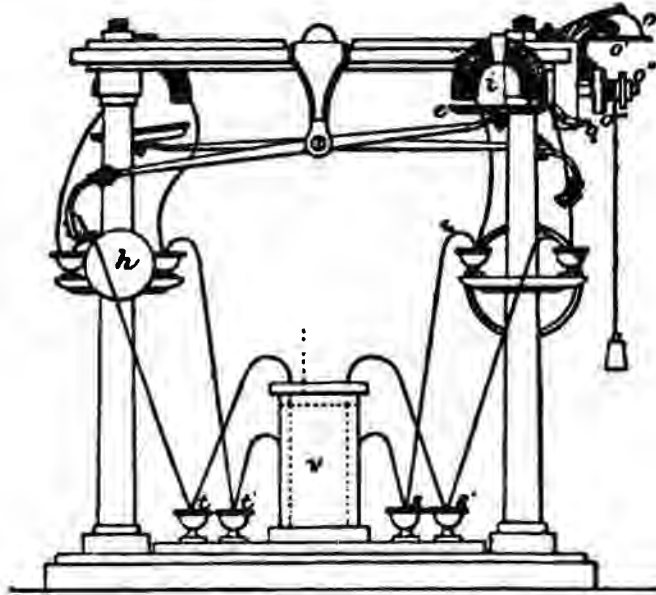

“The current was produced by a pair *v*, composed of a copper cylinder containing acidulated water, in which was plunged when required another cylinder of zinc. Wires from the copper and zinc poles dipped into little cups of mercury, into which were also plunged as required the terminal wires of the electro-magnets.

“In the above-mentioned paper Professor Stratingh stated that experiments made with this apparatus before the Physical Society of Groninque succeeded perfectly through twenty metres of line wire, but that when the distance was increased to one hundred metres the results were not so good, the current then proving to be insufficient.

“It would seem that the Professor did not continue his experiments. He was content with describing his plans ‘for what they were worth,’ and added that better results would probably be obtained (1), by increasing the force of the battery; (2), by employing insulated wires; (3), by the use of thicker wires; (4), by more delicately suspending the levers, &c. He even remarked that he had surrounded the armatures with covered wire in such a way that the current in circulating through this wire and through the coil *i*, should produce opposite poles in the contiguous parts of the armature and electro-magnet, which would make the attraction stronger.

FIG. 35.

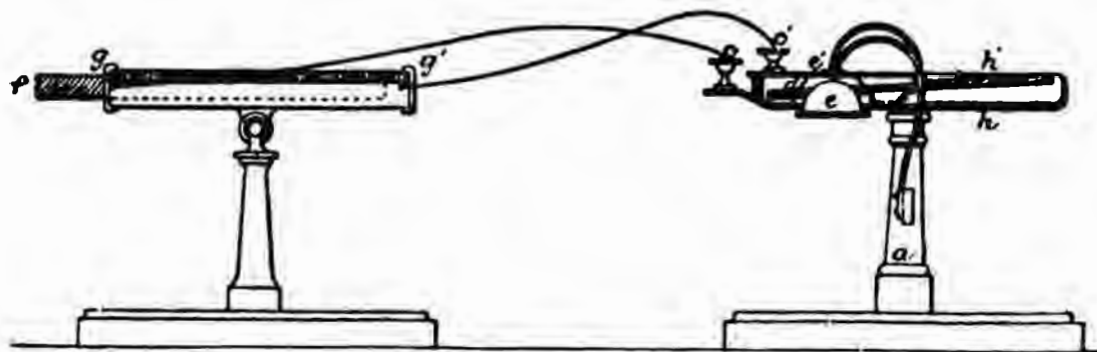

“In continuation of these experiments the Professor made and tried an acoustic apparatus of a simpler construction. This, as represented in Fig. 35, consisted of a stand *a*, supporting a copper band *h, h'*, bent on itself and holding cups of mercury into which dipped the wires coming from the electromotor. Within the band *h, h'*, was pivoted a bar magnet *d*,

which, when deflected to one side or the other, struck one of the bells  $e$ , or  $e'$ . Instead of the simple band of copper, Schweigger's multiplier coil could be used.

"As electromotor Stratingh employed a magneto-electric arrangement, consisting of a helix  $g$ ,  $g'$ , and a bar magnet  $f$ . By introducing  $f$ , into  $g$ ,  $g'$ , first from one side and then from the other, he caused the needle  $d$ , to be deflected, and so to strike the bell  $e$ , or  $e'$ , as required.

"The above, dear Sir, is the substance of Mr. Stratingh's paper, and I hope it will be sufficient for your purpose.

"Receive, &c.,

"COLLETTE."

#### 1837.—*Amyot's Telegraph.*

For much the same reason that we have noticed Stratingh's crude proposals, we must say a few words on another plan which dates from about the same time, and which, if we comprehend it rightly, must be regarded as the first automatic telegraph. Unfortunately, we know very little of Amyot's plans—no more, in fact, than is contained in the following paragraph which we extract from his *Note Historique*, in the *Compte Rendu*\* :—

"As for myself, after having studied the problem [of

\* For July 9, 1838, pp. 80-3. The *Journal des Travaux de l'Académie de l'Industrie Française*, for March 1839, p. 43, says that Amyot's note was addressed to the Academy of Sciences in April 1838; but the date of his telegraph appears to be still earlier, for it is referred to in the *Compte Rendu*, for December 26, 1837, p. 909.

electric telegraphy] as thoroughly as I could, I contrived an apparatus, with only one current and one needle, which itself wrote down on paper and with mathematical precision whatever a simple wheel [drum] at the distant end of the line transmitted. The signals were previously arranged on the wheel by means of points differently spaced, as on the wheels of our Barbary organs, and, as in these, the motion of the wheel was obtained from an ordinary clock spring. To transmit a despatch it was only necessary to set it up on the wheel by means of movable characters [types], and to deposit it in a box, and immediately it would be reproduced at the distant station on paper which was moved along regularly by a machine. The attendant had only to collect the paper and hand it to an *employé* who was specially charged with the interpretation of the ciphers. With such an apparatus no errors could possibly occur, for everything went like clockwork.

“As regards the conducting wires, it would suffice to put them out of the way of oxydation, by burying them in the earth, having previously coated them with a simple varnish of mineral pitch.

“I have communicated all my ideas on this subject to M. Savary, who has not only encouraged me in my experiments, but has assisted me with his great scientific knowledge.”

M. Guerout says that Amyot made a model of his machine at the request of Baron de Meyendorff, who

sent it to St. Petersburg,\* and that he vainly urged its adoption in his own country. M. Foy, the Sir John Barrow of the French semaphores, decided that the invention was public property, and that his department would make the instruments for itself when it was deemed necessary to do so.†

\* From a passage in Vail's *American Electro-Magnetic Telegraph*, p. 91, it would seem that in 1838 Amyot joined Morse in an attempt to introduce the latter's invention into Russia. Everything had been settled with Baron de Meyendorff, but at the last moment the Emperor refused his sanction. Why? See note p. 317.

† *La Lumière Électrique*, March 24, 1883, p. 364. In the *Compte Rendu*, for December 31, 1838, p. 1162, we find the following paragraph:—"M. Amyot, who had presented in the month of June [? December 1837] a note on a plan of correspondence by means of electric telegraphs, addressed to-day tables on a language and a system of signals which he proposed to be used in connection with this correspondence."





## APPENDIX A.

---

WE make the following extracts from the *Smithsonian Reports*, for 1857 and 1858 :—

*Communication from Professor Joseph Henry, Secretary of the Smithsonian Institution, relative to a Publication by S. F. B. Morse.*

“ Gentlemen,—In the discharge of the important and responsible duties which devolve upon me as Secretary of the Smithsonian Institution, I have found myself exposed, like other men in public positions, to unprovoked attack and injurious misrepresentation. Many instances of this, it may be remembered, occurred about two years ago, during the discussions relative to the organic policy of the Institution ; but, though very unjust, they were suffered to pass unnoticed, and generally made, I presume, no lasting impression on the public mind.

“ During the same controversy, however, there was one attack made upon me of such a nature, so elaborately prepared and widely circulated, by my opponents, that, though I have not yet publicly noticed it, I have, from the first, thought it my duty not to allow it to go unanswered. I allude to an article in a periodical entitled ‘Shaffner’s Telegraph Companion,’ from the pen of Professor S. F. B. Morse, the celebrated inventor of the American electro-magnetic telegraph. In this, not my scientific reputation merely, but my moral character was pointedly assailed; indeed, nothing less was attempted than to prove that in the testimony which I had given in a case where I was at most but a reluctant witness, I had consciously and wilfully

deviated from the truth, and this, too, from unworthy and dishonourable motives.

“Such a charge, coming from such a quarter, appeared to me then, as it appears now, of too grave a character and too serious a consequence to be withheld from the notice of the Board of Regents. I, therefore, presented the matter unofficially to the Chancellor of the Institution, Chief Justice Taney, and was advised by him to allow the matter to rest until the then existing excitement with respect to the organisation of the Institution should subside, and that in the meantime the materials for a refutation of the charge might be collected and prepared, to be brought forward at the proper time, if I should think it necessary.

“The article of Mr. Morse was published in 1855, but at the session of the Board in 1856 I was not prepared to present the case properly to your consideration, and I now (1857) embrace the first opportunity of bringing the subject officially to your notice, and asking from you an investigation into the justice of the charges alleged against me. And this I do most earnestly, with the desire that when we shall all have passed from this stage of being, no imputation of having attempted to evade in silence so grave a charge shall rest on *me*; nor on *you*, of having continued to devolve upon me duties of the highest responsibility, after that was known to some of you individually, which, if true, should render me entirely unworthy of your confidence. Duty to the Board of Regents, as well as regard to my own memory, to my family, and to the truth of history, demands that I should lay this matter before you, and place in your hands the documents necessary to establish the veracity of my testimony, so falsely impeached, and the integrity of my motives, so wantonly assailed.

“My life, as is known to you, has been principally devoted to science, and my investigations in different branches of physics have given me some reputation in the line of original discovery. I have sought, however, no patent for inventions, and solicited no remuneration for my labours, but have freely given their results to the world, expecting only, in return, to enjoy the

consciousness of having added, by my investigations, to the sum of human knowledge, and to receive the credit to which they might justly entitle me.

“ I commenced my scientific career about the year 1828, with a series of experiments in electricity, which were continued at intervals up to the period of my being honoured by election to the office of Secretary of this Institution. The object of my researches was the advancement of science, without any special or immediate reference to its application to the wants of life or useful purposes in the arts. It is true, nevertheless, that some of my earlier investigations had an important bearing on the electro-magnetic telegraph, and brought the science to that point of development at which it was immediately applicable to Mr. Morse's particular invention.

“ In 1831 I published a brief account of these researches, in which I drew attention to the fact of their applicability to the telegraph ; and in 1832, and subsequently, I exhibited experiments illustrative of the application of the electro-magnet to the transmission of power to a distance, for producing telegraphic and other effects. The results I had published were communicated to Mr. Morse, by his scientific assistant, Dr. Gale, as will be shown on the evidence of the latter ; and the facts which I had discovered were promptly applied in rendering effective the operation of his machine.

“ In the latter part of 1837 I became personally acquainted with Mr. Morse, and at that time, and afterwards, freely gave him information in regard to the scientific principles which had been the subject of my investigations. After his return from Europe, in 1839, our intercourse was renewed, and continued uninterrupted till 1845. In that year, Mr. Vail, a partner and assistant of Mr. Morse, published a work purporting to be a history of the Telegraph, in which I conceived manifest injustice was done me. I complained of this to a mutual friend, and subsequently received an assurance from Mr. Morse that if another edition were published, all just ground of complaint should be removed. A new emission of the work, however, shortly afterwards appeared, without change in this respect, or

2 K

further reference to my labours. Still I made no public complaint, and set up no claims on account of the telegraph. I was content that my published researches should remain as material for the history of science, and be pronounced upon, according to their true value, by the scientific world.

“ After this, a series of controversies and lawsuits having arisen between rival claimants for telegraphic patents, I was repeatedly appealed to, to act as *expert* and witness in such cases. This I uniformly declined to do, not wishing to be in any manner involved in these litigations, but was finally compelled, under legal process, to return to Boston from Maine, whither I had gone on a visit, and to give evidence on the subject. My testimony was given with the statement that I was not a willing witness and that I laboured under the disadvantage of not having access to my notes and papers, which were in Washington. That testimony, however, I now reaffirm to be true in every essential particular. It was unimpeached before the court, and exercised an influence on the final decision of the question at issue.

“ I was called upon on that occasion to state, not only what I had published, but what I had done, and what I had shown to others in regard to the telegraph. It was my wish, in every statement, to render Mr. Morse full and scrupulous justice. While I was constrained, therefore, to state that he had made no discoveries in science, I distinctly declared that he was entitled to the merit of combining and applying the discoveries of others, in the invention of the best practical form of the magnetic telegraph. My testimony tended to establish the fact that, though not entitled to the exclusive use of the electro-magnet for telegraphic purposes, he was entitled to his particular machine, register, alphabet, &c. As this, however, did not meet the full requirements of Mr. Morse's comprehensive claim, I could not but be aware that, while aiming to depose nothing but truth and the whole truth, and while so doing being obliged to speak of my own discoveries, and to allude to the omissions in Mr. Vail's book, I might expose myself to the possible, and, as it has proved, the actual, danger of having my motives misconstrued and my testimony misrepresented. But I can truly aver, in

accordance with the statement of the counsel, Mr. Chase (now Governor of Ohio), that I had no desire to arrogate to myself undue merit, or to detract from the just claims of Mr. Morse.

“ I have the honour to be, your obedient servant,

“ JOSEPH HENRY.

“ To the Board of Regents.”

*Report of the Special Committee of the Board of Regents on the  
Communication of Professor Henry.*

“ Washington, May 19, 1858.

“ Professor Henry laid before the Board of Regents of the Smithsonian Institution a communication relative to an article in Shaffner's Telegraph Companion, bearing the signature of Samuel F. B. Morse, the inventor of the American electro-magnetic telegraph. In this article serious charges are brought against Professor Henry, bearing upon his scientific reputation and his moral character. The whole matter having been referred to a committee of the Board, with instructions to report on the same, the committee have attended to the duty assigned to them, and now submit the following brief report, with resolutions accompanying it.

“ The committee have carefully examined the documents relating to the subject, and especially the article to which the communication of Professor Henry refers. This article occupies over ninety pages, filling an entire number of Shaffner's Journal, and purports to be ‘ a defence against the injurious deductions drawn from the deposition of Professor Joseph Henry (in the several telegraph suits), with a critical review of said deposition, and an examination of Professor Henry's alleged discoveries bearing upon the electro-magnetic telegraph.’

“ The first thing which strikes the reader of this article is, that its title is a misnomer. It is simply an assault upon Professor Henry ; an attempt to disparage his character ; to deprive him of his honours as a scientific discoverer ; to

2 K 2

impeach his credibility as a witness and his integrity as a man. It is a disingenuous piece of sophistical argument, such as an unscrupulous advocate might employ to pervert the truth, misrepresent the facts, and misinterpret the language in which the facts belonging to the other side of the case are stated.

“Mr. Morse charges that the deposition of Professor Henry ‘contains imputations against his (Morse’s) personal character,’ which it does not, and assumes it as a duty ‘to expose the utter non-reliability of Professor Henry’s testimony;’ that testimony being supported by the most competent authorities, and by the history of scientific discovery. He asserts that he ‘is not indebted to him (Professor Henry) for any discovery in science bearing on the telegraph,’ he having himself acknowledged such indebtedness in the most unequivocal manner, and the fact being independently substantiated by the testimony of Sears C. Walker, and the statement of Mr. Morse’s own associate, Dr. Gale. Mr. Morse further maintains, that all discoveries bearing upon the telegraph, were made, not by Professor Henry, but by others, and prior to any experiments of Professor Henry in the science of electro-magnetism; contradicting in this proposition the facts in the history of scientific discovery perfectly established and recognised throughout the scientific world.

“The essence of the charges against Professor Henry is, that he gave false testimony in his deposition in the telegraph cases, and that he has claimed the credit of discoveries in the sciences bearing upon the electro-magnetic telegraph which were made by previous investigators; in other words, that he has falsely claimed what does not belong to him, but *does* belong to others.

“Professor Henry, as a private man, might safely have allowed such charges to pass in silence. But standing in the important position which he occupies, as the chief executive officer of the Smithsonian Institution; and regarding the charges as undoubtedly containing an impeachment of his moral character, as well as of his scientific reputation; and justly sensitive, not only for his own honour, but for the honour of the Institution,

he has a right to ask this Board to consider the subject, and to make their conclusions a matter of record, which may be appealed to hereafter should any question arise with regard to his conduct in the premises.

“Your committee do not conceive it to be necessary to follow Mr. Morse through all the details of his elaborate attack. Fortunately, a plain statement of a few leading facts will be sufficient to place the essential points of the case in a clear light.

“The deposition already referred to was reluctantly given, and under the compulsion of legal process, by Professor Henry, before the Hon. George S. Hillard, United States Commissioner, on the 7th of September, 1849.

\* \* \* \* \*

“Previous to this deposition, Mr. Morse, as appears from his own letters and statements, entertained for Professor Henry the warmest feelings of personal regard, and the highest esteem for his character as a scientific man. In a letter, dated April 24, 1839, he thanks Professor Henry for a copy of his ‘valuable contributions,’ and says, ‘I perceive many things (in the contributions) of great interest to me in my telegraphic enterprise.’ Again, in the same letter, speaking of an intended visit to the Professor at Princeton, he says: ‘I should come as a learner, and could bring no ‘contributions’ to your stock of experiments of any value.’ And still further: ‘I think that you have pursued an original course of experiments, and discovered facts more immediately bearing upon my invention than any that have been published abroad.’

“It appears from Mr. Morse’s own statement, that he had at least two interviews with Professor Henry—one in May 1839, when he passed the afternoon and night with him, at Princeton; and another in February 1844—both of them for the purpose of conferring with him on subjects relating to the telegraph, and evidently with the conviction, on Mr. Morse’s part, that Professor Henry’s investigations were of great importance to the success of the telegraph.

“As late as 1846, after Mr. Morse had learned that some dis-



satisfaction existed in Professor Henry's mind in regard to the manner in which his researches in electricity had been passed over by Mr. Vail, an assistant of Mr. Morse, and the author of a history of the American magnetic telegraph, Mr. Morse, in an interview with Professor Henry, at Washington, said, according to his own account, 'Well, Professor Henry, I will take the earliest opportunity that is afforded me in anything I may publish, to have justice done to your labours; for I do not think that justice has been done you, either in Europe or this country.'

"Again, in 1848, when Professor Walker, of the Coast Survey, made his report on the theory of Morse's electro-magnetic telegraph, in which the expression occurred, 'the helix of a soft iron magnet, prepared after the manner first pointed out by Professor Henry,' Mr. Morse, to whom the report was submitted, said: 'I have now the long-wished-for opportunity to do justice publicly to Henry's discovery bearing on the telegraph.' And in a note prepared by him, and intended to be printed with Professor Walker's report, he says: 'The allusion you make to the helix of a soft iron magnet, prepared after the manner first pointed out by Professor Henry, gives me an opportunity, of which I gladly avail myself, to say that I think that justice has not yet been done to Professor Henry, either in Europe or in this country, for the discovery of a scientific fact, which, in its bearing on telegraphs, whether of the magnetic needle or electro-magnet order, is of the greatest importance.'

"He then proceeds to give an historical synopsis, showing that, although suggestions had been made and plans devised by Soemmering, in 1811, and by Ampère, in 1820, yet that the experiments of Barlow, in 1824, had led that investigator to pronounce 'the idea of an electric telegraph to be chimerical'—an opinion that was, for the time, acquiesced in by scientific men. He shows that, in the interval between 1824 and 1829, no further suggestions were made on the subject of electric telegraphs. Then he proceeds: 'In 1830, Professor Henry, assisted by Dr. Ten Eyck, while engaged in experiments on the application of the principle of the galvanic multiplier to the development of great magnetic power in soft iron, made the important discovery that

a battery of intensity overcame that resistance in a long wire which Barlow had announced as an insuperable bar to the construction of electric telegraphs. Thus was opened the way for fresh efforts in devising a practicable electric telegraph; and Baron Schilling, in 1832, and Professors Gauss and Weber, in 1833, had ample opportunity to learn of Henry's discovery, and avail themselves of it, before they constructed their needle telegraphs.' And, while claiming for himself that he was 'the first to propose the use of the electro-magnet for telegraphic purposes, and the first to construct a telegraph on the basis of the electro-magnet,' yet he adds, '*to Professor Henry is unquestionably due the honour of the discovery of a principle which proves the practicability of exciting magnetism through a long coil, or at a distance, either to deflect a needle or to magnetise soft iron.*'

"What Mr. Morse here describes as a 'principle,' the discovery of which is unquestionably due to Professor Henry, is the law which first made it possible to work the telegraphic machine invented by Mr. Morse, and for the knowledge of which Mr. Morse was indebted to Professor Henry, as is positively asserted by his associate, Dr. Gale. This gentleman, in a letter, dated Washington, April 7, 1856, makes the following conclusive statement:—

“ ‘ Washington, D. C., April 7, 1856.

“ ‘ Sir,—In reply to your note of the 3rd instant, respecting the Morse telegraph, asking me to state definitely the condition of the invention when I first saw the apparatus in the winter of 1836, I answer: This apparatus was Morse's original instrument, usually known as the type apparatus, in which the types, set up in a composing stick, were run through a circuit breaker, and in which the battery was the cylinder battery, with a single pair of plates. This arrangement also had another peculiarity, namely, it was the electro-magnet used by Moll, and shown in drawings of the older works on that subject, having only a few turns of wire in the coil which surrounded the poles or arms of the magnet. The sparseness of the wires in the magnet coils

and the use of the single cup battery were to me, on the first look at the instrument, obvious marks of defect, and I accordingly suggested to the Professor, without giving my reasons for so doing, that a battery of many pairs should be substituted for that of a single pair, and that the coil on each arm of the magnet should be increased to many hundred turns each ; which experiment, if I remember aright, was made on the same day with a battery and wire on hand, furnished I believe by myself, and it was found that while the original arrangement would only send the electric current through a few feet of wire, say fifteen to forty, the modified arrangement would send it through as many hundred. Although I gave no reasons at the time to Professor Morse for the suggestions I had proposed in modifying the arrangement of the machine, I did so afterwards, and referred in my explanations to the paper of Professor Henry, in the nineteenth volume of the American Journal of Science, p. 400 and onward. It was to these suggestions of mine that Professor Morse alludes in his testimony before the Circuit Court for the eastern district of Pennsylvania, in the trial of B. B. French and others *v.* Rogers and others.—See printed copy of Complainant's Evidence, p. 168, beginning with the words 'Early in 1836 I procured 40 feet of wire,' &c., and p. 169, where Professor Morse alludes to myself and compensation for services rendered to him, &c.

“At the time I gave the suggestions above named, Professor Morse was not familiar with the then existing state of the science of electro-magnetism. Had he been so, or had he read and appreciated the paper of Henry, the suggestions made by me would naturally have occurred to his mind as they did to my own. But the principal part of Morse's great invention lay in the mechanical adaptation of a power to produce motion, and to increase or relax at will. It was only necessary for him to know that such a power existed for him to adapt mechanism to direct and control it.

“My suggestions were made to Professor Morse from inferences drawn by reading Professor Henry's paper above alluded to. Professor Morse professed great surprise at the

contents of the paper when I showed it to him, but especially at the remarks on Dr. Barlow's results respecting telegraphing, which were new to him, and he stated at the time that he was not aware that any one had even conceived the idea of using the magnet for such purposes.

“ ‘ With sentiments of esteem, I remain, yours truly,

“ ‘ L. D. DALE.

“ ‘ Prof. Jos. Henry,

“ ‘ Secretary of the Smithsonian Institution.’

\* \* \* \* \*

“ It thus appears, both from Mr. Morse's own admission down to 1848, and from the testimony of others most familiar with the facts, that Professor Henry discovered the law, or ‘ principle,’ as Mr. Morse designates it, which was necessary to make the practical working of the electro-magnetic telegraph at considerable distances possible; that Mr. Morse was first informed of this discovery by Dr. Gale; that he availed himself of it at once, and that it never occurred to Mr. Morse to deny this fact until after 1848. He had steadily and fully acknowledged the merits and genius of Mr. Henry, as the discoverer of facts and laws in science of the highest importance in the success of his long-cherished invention of a magnetic telegraph. Mr. Henry was the discoverer of a principle, Mr. Morse was the inventor of a machine, the object of which was to record characters at a distance, to convey intelligence, in other words, to carry into execution the idea of an electric telegraph. But there were obstacles in the way which he could not overcome until he learned the discoveries of Professor Henry, and applied them to his machine. These facts are undeniable. They constitute a part of the history of science and invention. They were true in 1848, they were equally true in 1855, when Professor Morse's article was published.

\* \* \* \* \*

“ What changed Mr. Morse's opinion of Professor Henry, not only as a scientific investigator, but as a man of integrity, after the admissions of his indebtedness to his researches, and the oft-

repeated expressions of warm personal regard? It appears that Mr. Morse was involved in a number of lawsuits, growing out of contested claims to the right of using electricity for telegraphic purposes. The circumstances under which Professor Henry, as a well-known investigator in this department of physics, was summoned by one of the parties to testify have already been stated. The testimony of Mr. Henry, while supporting the claims of Mr. Morse as the inventor of an admirable invention, denied to him the additional merit of being a discoverer of new facts or laws of nature, and to this extent, perhaps, was considered unfavourable to some part of the claim of Mr. Morse to an *exclusive* right to employ the electro-magnet for telegraphic purposes. Professor Henry's deposition consists of a series of answers to verbal, as well as written, interrogatories propounded to him, which were not limited to his published writings, or the subject of electricity, but extended to investigations and discoveries in general having a bearing upon the electric telegraph. He gave his testimony at a distance from his notes and manuscripts, and it would not have been surprising if inaccuracies had occurred in some parts of his statement ; but all the material points in it are sustained by independent testimony, and that portion which relates directly to Mr. Morse agrees entirely with the statement of his own assistant, Dr. Gale. Had his deposition been objectionable, it ought to have been impeached before the Court ; but this was not attempted ; and the following tribute to Professor Henry by the Judge, in delivering the opinion of the Supreme Court of the United States, indicates the impression made upon the Court itself by all the testimony in the case : ' It is due to him to say that no one has contributed more to enlarge the knowledge of electro-magnetism, and to lay the foundations of the great inventions of which we are speaking, than the Professor himself.'

“ Professor Henry's answers to the first and second interrogatories present a condensed history of the progress of the science of electro-magnetism, as connected with telegraphic communication, embracing an account of the discoveries of Oersted, Arago, Davy, Ampère ; of the investigations by Barlow and

Sturgeon; of his own researches, commenced in 1828, and continued in 1829, 1830, and subsequently. The details of his experiments and their results, though brief, are very precise. There is abundant evidence to show that Professor Henry's experiments and illustrations at Albany [in 1831], and subsequently at Princeton, proved, and were declared at the time by him to prove, that the electric telegraph was now practicable; that the electro-magnet might be used to produce mechanical effects at a distance adequate to making signals of various kinds, such as ringing bells, which he practically illustrated. In proof of this, we quote a letter to Professor Henry, from Professor James Hall, of Albany, late president of the American Association for the Advancement of Science.

“ ‘ January 19, 1856.

“ ‘ Dear Sir,—While a student of the Rensselaer School, in Troy, New York, in August 1832, I visited Albany with a friend, having a letter of introduction to you from Professor Eaton. Our principal object was to see your electro-magnetic apparatus, of which we had heard much, and at the same time the library and collections of the Albany Institute.

“ ‘ You showed us your laboratory in a lower story or basement of the building, and in a larger room in an upper story some electric and galvanic apparatus, with various philosophical instruments. In this room, and extending around the same, was a circuit of wire stretched along the wall, and at one termination of this, in the recess of a window, a bell was fixed, while the other extremity was connected with a galvanic apparatus.

“ ‘ You showed us the manner in which the bell could be made to ring by a current of electricity, transmitted through this wire, and you remarked that this method might be adopted for giving signals, by the ringing of a bell at the distance of many miles from the point of its connection with the galvanic apparatus.

“ ‘ All the circumstances attending this visit to Albany are fresh in my recollection, and during the past years, while so much has been said respecting the invention of electric telegraphs, I have often had occasion to mention the exhibition of your electric telegraph in the Albany Academy, in 1832.

“ ‘ If at any time or under any circumstances this statement can be of service to you in substantiating your claim to such a discovery at the period named, you are at liberty to use it in any manner you please, and I shall be ready at all times to repeat and sustain what I have here stated, with many other attendant circumstances, should they prove of any importance.

“ ‘ I remain, very sincerely and respectfully, yours,

“ ‘ JAMES HALL.\*

“ ‘ Professor Joseph Henry.’

“ In his deposition, Professor Henry’s statements are within what he might fairly have claimed. But he is a man of science, looking for no other reward than the consciousness of having done something for its promotion, and the reputation which the successful prosecution of scientific investigations and discoveries may justly be expected to give. In his public lectures and published writings he has often pointed out incidentally the possibility of applying the facts and laws of nature discovered by him to practical purposes; he has freely communicated information to those who have sought it from him, among whom

---

\* In the American telegraph suit, *Smith v. Downing*, Oliver Byrne gave evidence as follows:—

“ In the year 1830, I attended the public lectures of Abraham Booth (afterward scientific reporter for *The Times* newspaper, and who became Dr. Booth), delivered in Dublin, among other subjects, on electricity and electro-magnetism. In said lectures, the said Booth, in my presence, used in combination a long circuit of insulated wire conductors, a galvanic battery, an electro-magnet with an armature and mercury cups to join and disjoin the circuit, with which he magnetised and demagnetised the iron of the electro-magnet, causing it to attract the armature when the circuit was joined, and to recede from it [allow it to fall away] when disjoined. Mr. Booth, at that time, stated to his audiences that that power could be produced and used at distant places, as signs of information; and he repeatedly illustrated what he meant, by causing the armature to approach the magnet, and then to fall from it on the floor, stating at the same time that it made marks by so falling.”—*Jones’ Historical Sketch of the Electric Telegraph, &c.*, New York, 1852, p. 32.

has been Mr. Morse himself, as appears by his own acknowledgments. But he has never applied his scientific discoveries to practical ends for his own pecuniary benefit. It was natural, therefore, that he should feel a repugnance to taking any part in the litigation between rival inventors, and it was inevitable that, when forced to give his testimony, he should distinctly point out what was so clear in his own mind and is so fundamental a fact in the history of human progress, the distinctive functions of the discoverer, and the inventor who applies discoveries to practical purposes in the business of life.

“ Mr. Henry has always done full justice to the invention of Mr. Morse. While he could not sanction the claim of Mr. Morse to the *exclusive* use of the electro-magnet, he has given him full credit for the mechanical contrivances adapted to the application of his invention. In proof of this we refer to his deposition, and present also the following statement of Hon. Charles Mason, Commissioner of Patents, taken from a letter addressed by him to Professor Henry, dated March 31, 1856:—

“ ‘ U.S. Patent Office, March 31, 1856.

“ ‘ Sir,—Agreeably to your request, I now make the following statement :

“ ‘ Some two years since, when an application was made for an extension of Professor Morse’s patent, I was for some time in doubt as to the propriety of making that extension. Under these circumstances I consulted with several persons, and among others with yourself, with a view particularly to ascertain the amount of invention fairly due to Professor Morse.

“ ‘ The result of my inquiries was such as to induce me to grant the extension. I will further say that this was in accordance with your express recommendation, and that I was probably more influenced by this recommendation and the information I obtained from you, than by any other circumstance, in coming to that conclusion.

“ ‘ I am, Sir, yours very respectfully,

“ ‘ CHARLES MASON.

“ ‘ Professor J. Henry.’



“ To sum up the result of the preceding investigation in a few words.

“ We have shown that Mr. Morse himself has acknowledged the value of the discoveries of Professor Henry to his electric telegraph ; that his associate and scientific assistant, Dr. Gale, has distinctly affirmed that these discoveries were applied to his telegraph, and that previous to such application it was impossible for Mr. Morse to operate his instrument at a distance ; that Professor Henry’s experiments were witnessed by Professor Hall and others in 1832, and that these experiments showed the possibility of transmitting to a distance a force capable of producing mechanical effects adequate to making telegraphic signals ; that Mr. Henry’s deposition of 1849, which evidently furnished the motive for Mr. Morse’s attack upon him, is strictly correct in all the historical details, and that, so far as it relates to Mr. Henry’s own claim as a discoverer, is within what he might have claimed with entire justice ; that he gave the deposition reluctantly, and in no spirit of hostility to Mr. Morse ; that on that and other occasions he fully admitted the merit of Mr. Morse as an inventor ; and that Mr. Morse’s patent was extended through the influence of the favourable opinion expressed by Professor Henry.

“ Your committee come unhesitatingly to the conclusion that Mr. Morse has failed to substantiate any one of the charges he has made against Professor Henry, although the burden of proof lay upon him ; and that all the evidence, including the unbiassed admissions of Mr. Morse himself, is on the other side. Mr. Morse’s charges not only remain unproved, but they are positively disproved.”

Extract from Professor Henry’s evidence in the Telegraph suit of Morse *v.* O’Reilly, Boston, September, 1849 :—

“ In February 1837, I went to Europe ; and early in April of that year Professor Wheatstone, of London, in the course of a visit to him in King’s College, London, with Professor Bache, now of the Coast Survey, explained to us his plans of an electro-

magnetic telegraph ; and, among other things, exhibited to us his method of bringing into action a second galvanic circuit. This consisted in closing the second circuit by the deflection of a needle, so placed that the two ends of the open circuit projecting upwards would be united by the contact of the end of the needle when deflected, and of opening or breaking the circuit so closed by opening the first circuit and thus interrupting the current, when the needle would resume its ordinary position under the influence of the magnetism of the earth. I informed him that I had devised another method of producing effects somewhat similar. This consisted in opening the circuit of my large quantity magnet at Princeton, when loaded with many hundred pounds weight, by attracting upward a small piece of movable wire, with a small intensity magnet, connected with a long wire circuit. When the circuit of the large battery was thus broken by an action from a distance, the weights would fall, and great mechanical effect could thus be produced, such as the ringing of church bells at a distance of a hundred miles or more, an illustration which I had previously given to my class at Princeton. My impression is strong, that I had explained the precise process to my class before I went to Europe, but testifying now without the opportunity of reference to my notes, I cannot speak positively. I am, however, certain of having mentioned in my lectures every year previously, at Princeton, the project of ringing bells at a distance, by the use of the electro-magnet, and of having frequently illustrated the principle of transmitting power to a distance to my class, by causing in some cases a thousand pounds to fall on the floor, by merely lifting a piece of wire from two cups of mercury closing the circuit.

“ The object of Professor Wheatstone, as I understood it, in bringing into action a second circuit, was to provide a remedy for the diminution of force in a long circuit. My object, in the process described by me, was to bring into operation a large quantity magnet, connected with a quantity battery in a local circuit, by means of a small intensity magnet, and an intensity battery at a distance.”

Up to the date of Henry's visit to Wheatstone in February 1837, the latter did not know how to construct an "intensity" electro-magnet. It will be remembered by all readers of Mr. Latimer Clark's interesting biography of Sir W. F. Cooke,\* that it was a difficulty of this kind that first brought Cooke and Wheatstone together. Cooke had contrived a telegraph and alarum, to be operated by clockwork mechanism, the detents of which were to be released, as occasion required, by electro-magnets. The apparatus worked well enough on short circuit, but when he came to try it through such lengths as a mile of wire, the electro-magnets were so enfeebled that they could not withdraw the detents. In this difficulty Cooke sought the advice of Roget, Faraday, Clarke, and Wheatstone.

The latter's opinion was very unfavourable. "Relying," he says, "on my former experience, I at once told Mr. Cooke that his plan would not and could not act as a telegraph, because sufficient attractive power could not be imparted to an electro-magnet interposed in a long circuit; and to convince him of the truth of this assertion, I invited him to King's College to see the repetition of the experiments on which my conclusion was founded. He came, and after seeing a variety of voltaic magnets, which even with powerful batteries exhibited only slight adhesive attraction, he expressed his disappointment."

\* *Journal of the Soc. of Tel. Engrs.*, vol. viii. p. 374.

And again :—"When I endeavoured to ascertain how a bell might be more efficiently rung, the attractive power obtained by temporarily magnetising soft iron first suggested itself to me. The experiments I made with the long circuit at King's College, however, led me to conclude that the attraction of a piece of soft iron by an electro-magnet could not be made available in circuits of very great length, and, therefore, I had no hopes of being able to discharge an alarum by this means." \*

In reference to these experiments, Cooke wrote on March 4, 1837 :—

"Mr. Wheatstone called on Monday evening, and postponed our meeting at King's College till Wednesday. The result was nearly what I had anticipated, the electric fluid losing its magnetising quality in a lengthened course. An idea, however, suggested itself to Mr. Wheatstone, which I prepared to experiment on last Saturday, but again failed in producing any effect. I gave up my object for the time, and proposed explaining the nature of my discomfited instrument to the Professor. He, in return, imparted his to me. He handsomely acknowledged the advantage of mine, had it acted ; his are ingenious, but not practicable. His favourite is the same as mine, made at Heidelberg, and now in one of my boxes at Berne, requiring six wires, and a very delicate arrangement. He proposed that we should meet again next Saturday, and make further experiments. For a time I felt relieved at having decided the fate of my own plan, but my mind returned to the subject with more perseverance than ever, and before three o'clock the next morning I had re-arranged my unfortunate machine under a new shape.

---

\* *The Electric Telegraph, was it invented by Professor Wheatstone?* by W. F. Cooke, London, 1856-57. See part ii. pp. 87 and 93.

“ I now use a true [permanent] magnet of considerable power, with the poles about four inches apart, and a slender armature, four and a half inches long, covered with several hundred coils of insulated copper wire, and suspended like a mariner’s compass in the plane of the poles of the magnet. Whenever the galvanic circuit is completed, the ends of the armature are respectively attracted by the poles of the magnet with a force sufficient to overcome the opposition of a feeble spring, the movement not exceeding one-twentieth of an inch. A lever forming part of the detent of my fan is moved by a projecting pin, and liberates the clockwork. I have seen an arrangement of this sort in the Adelaide Gallery, but used there merely as a toy.”\*

Even this arrangement, which was obviously capable of good results, and in which our practical readers will recognise the germ of the Brown and Allan relay was not approved by Professor Wheatstone. Cooke writes :—“ On many occasions during the months of March and April 1837, we tried experiments together upon the electro-magnet ; our object being to make it act efficiently at long distances in its office of removing the detent. The result of our experiments confirmed my apprehension that I was still without the power of exciting magnetism at long distances.

\* \* \* In this difficulty we adopted the expedient of a secondary circuit, which was used *for some time* in connection with my alarum.” †

“ From all this,” says Mr. Latimer Clark, “ it is evident that Professor Wheatstone at this time [April 1837] did not appreciate the importance of using fine

\* *Four. Soc. Tel. Engs.*, vol. viii. p. 378.

† The italics are our own. See *The Electric Telegraph, was it invented by Professor Wheatstone?* part ii. p. 27.

wire, and that he had not studied Professor Henry's paper on electro-magnets, in the twentieth volume of *Silliman's Journal*, for January 1831, in which he so clearly shows the advantage of using long fine wires [in the coils] and numerous elements for long circuits." \*

It is equally evident that it was not until *after* the interview with Henry that Wheatstone recognised the applicability of Ohm's laws to telegraphic circuits, the study of which would, likewise, have enabled him to ascertain the best proportions between the length, thickness, &c., of the coils, as compared with the other resistances in the circuit, and to determine the number and size of the elements of the battery necessary to produce a maximum effect.†

\* *Jour. Soc. Tel. Engs.*, vol. viii. p. 381.

† As soon as Professor Wheatstone had thus learnt how to construct an "intensity" electro-magnet, the use of the secondary or relay circuit referred to on pp. 511 and 514 was abandoned. "These secondary circuits," says Wheatstone, "have lost nearly all their importance, and are scarcely worth contending about, since my discovery that electro-magnets may be so constructed as to produce the required effects by means of the direct current, even in very long circuits. Previously, however, to this discovery they appeared to be of great importance to both of us—to me, as the means of ringing the alarm connected with my telegraph; to Mr. Cooke, as the only means of enabling him to work his instrument."—*The Electric Telegraph, was it invented by Professor Wheatstone?* part ii. pp. 95-6.

As these words were written in the winter of 1840-41, they must be taken to represent Professor Wheatstone's estimate of the relay at that date. It was not thus that Edward Davy appraised it. From *March 1837 onward* he steadily regarded it to be what it is—one of the key-stones of electric telegraphy. See pp. 359 and 366, *ante*.

## APPENDIX B.

---

*Short Memoir of Edward Davy, M.R.C.S., M.S.A.* By HENRY DAVY, M.D. (Lond.), M.R.C.P., Physician to the Devon and Exeter Hospital. Reprinted from "*The Electrician*," No. 11, vol. xi., 1883.

The following short biographical sketch of my uncle has been written by me at the request of Mr. Fahie in order to complete the history of the MSS. which he has lately published :—

Edward Davy's family originally settled near the coast in Dorsetshire, where, about the year 1616, they were living on their own estates. Unfortunately, they took an active part against the king in the Monmouth Rebellion, and, when Judge Jefferys commenced the "Bloody Assize," they found it convenient to migrate into Devonshire, where they commenced life afresh, mostly pursuing the occupation of farmers. His grandfather was a farmer, partly owning, and partly renting, his estates in the neighbourhood of Exeter; while his father was Thomas Davy, who resided at Ottery St. Mary, and had an extensive medical practice in Ottery and the neighbourhood. Thomas Davy was educated at Ottery and Guy's Hospital, at the latter, being a pupil of Sir Astley Cooper, but from the time he left London it is much to be questioned whether he was ever out of Devonshire more than five or six times in his life.

Edward Davy was born on June 6, 1806, and was educated at a school kept by his maternal uncle, Mr. Boutflower, in Tower Street, London. Subsequently he was apprenticed to Mr. Wheeler, house surgeon at St. Bartholomew's Hospital, and, about the year 1828, he became a "Member of the Royal

College of Surgeons," and soon after a "Member of the Society of Apothecaries." Shortly after this he bought a business at 390, Strand. I have always heard it stated that some eight or nine hundred pounds were advanced by his father to buy a medical practice, but that he was taken in, and found that the so-called practice was that of a dispensing chemist. However this may be, he soon began to trade as an operative chemist, under the name of Davy and Co., and in 1836 he published a small work, termed "Experimental Guide to Chemistry," at the end of which is a catalogue of the instruments, &c., supplied by his firm. This guide book might even now serve as a useful text-book for a beginner in experimental work, whilst in the catalogue at the end he mentions several of his original modifications of instruments, such as "Davy's Blow-pipe," "Davy's Improved Mercurial Trough," &c., proving how completely he had given himself up to his favourite pursuit.

About this time, 1835, he invented and patented a cement for mending broken china and glass, which for many years brought him in a small income, and was well known as "Davy's Diamond Cement," and it was during these years that he first commenced to experiment on the Electric Telegraph; but this part of his history up to the time of his leaving England has already been told by Mr. Fahie. One question which will be asked by all the readers of Mr. Fahie's narrative is: Why did Edward Davy fail in his attempt to get his system of telegraphy adopted? It seems certain that at the time of his leaving England his system was in a more perfect state than that of Cooke and Wheatstone. It is seen, too, that Edward Davy was and had been negotiating with some of the leading engineers, railway companies, and railway directors, and that many of them had promised to adopt his system. Why, then, did he fail? Chiefly because he left England just at the wrong moment. Into the reasons of his leaving there is no occasion to enter. Suffice it to say he had been contemplating doing so all through the end of 1837 and 1838, and that his reasons were entirely of a private kind. But in leaving England when he did, he struck the death-blow to all his hopes; and had he remained,



his system, as Mr. Fahie says, would probably have been adopted. It is important to note that he himself did not realise the fact that his leaving England would ruin his invention, and that had he realised his true position he would probably have stayed on until his negotiations with the railway companies were concluded. In a letter to his father early in 1839, in which he announces his final decision to leave, he says :—

“I have perfected, as far as I can, secured, and made public the telegraph. What remains, *i. e.*, to make the bargain with the companies when they are ready and willing, can be managed by an agent or attorney as well as if I were present.”

How entirely wrong this opinion was subsequent events soon proved, for the directors, having no one to deal with who thoroughly understood his instruments, adopted those of his rivals, Cooke and Wheatstone.

But other causes greatly contributed to his failure. The first is brought out in the sketch I have given of his family. His father was, for his day, a well-qualified medical man, but he was quite destitute of any scientific training, whilst his close residence in Devonshire had prevented his seeing the direction in which the thought of the day was moving. To most people in 1837 the idea even of a railway was new ; and when Edward Davy talked of “*sending messages along a wire for hundreds of miles,*” when he predicted the use of “*marine cables,*” hinted at the “*telephone,*” and prophesied that the “*Government would adopt the telegraph as part of their postal system,*” it is excusable that his father should regard him as a visionary, and should tell him that his plans were all “*moonshine.*” When, too, he found that he had to pay for this “*moonshine*” by constant remittances, one can easily forgive his anxiety that his son should go back to the regular practice of his profession ; especially when to his old-fashioned ideas it was almost a disgrace for a medical man to have a son an operative chemist. Not only did his father discourage Edward Davy in his pursuits, but he took no pains to bring his invention to the notice of many influential friends, who might have helped him in his endeavours to make it known to the public.

From Mr. Fahie's narrative, it seems evident that had any well-known firm taken up the invention, and pressed its advantages on the public, the railway directors would have adopted it. Thomas Davy's brother was a merchant of wide local reputation, who at one time had been one of the Government's largest contractors for building wooden frigates, while his nephew was a rising partner in one of the best-known and largest mercantile houses of the day (Anthony Gibbs and Co.), and yet neither of these was in the least made acquainted with the patent of the electric telegraph. This was the more deplorable, since Edward Davy was evidently unfortunate in his choice of business men. Repeatedly in his letters to his father he states that neither Mr. P—— nor Captain B—— nor Mr. B—— was assisting him as he should wish, and had he been assisted by any energetic man of business it is probable that Mr. Fahie's history would have ended very differently. Like most other geniuses, Edward Davy had no marked business capacity; he could invent an original machine, he was not able to hold his own with far-seeing men of the world. He had no friend to advise him, and he was unfortunate in the agents whose assistance he obtained. Had he offered 50 per cent. of his eventual gains he would have attracted the service of men of acknowledged position. As it was, his offer of 10 per cent. did not attract these, and even when he offered 25 per cent. to Mr. P——, the latter did not keep his part of the undertaking, so that the compact broke through. After careful perusal of the MSS., I am convinced that Edward Davy did everything in his own power to make his invention succeed; he failed because he had little business capacity, and his father's line of action prevented his getting even friendly advice from quarters where it might have been obtained. But the questions will be asked, Why has Edward Davy allowed his claims as a pioneer in telegraphy to be so completely ignored? And why have not his family published these MSS. before?

The answer to the latter question is simple. I very much doubt if the family knew anything about these MSS. They were collected and labelled by another uncle of mine long since dead, and it was only after the death of my father last year that

they fell into my hands, after having narrowly escaped being burned as rubbish. They came into my possession last March [1883], and when by chance Mr. Fabie in April 1883 wrote to ask me for information as to my uncle, I readily placed them at his disposal, only stipulating that, as he was quite a stranger to me, he should publish nothing without my permission. Until I saw his annotations I was not aware of the extent of Edward Davy's inventions, and I am quite sure my father had no idea as to the value of these MSS., for his training as a solicitor had not taught him any science.

I do not know why Edward Davy himself allowed his claims to be ignored. Probably he did not know that these MSS. had been preserved, and without them he would have no proof with which to support his claims.\* After leaving England in 1839 he threw all his energies into the colonial life he had adopted. His letters to his father, mother, and brothers are full of references to this new mode of life. He busied himself in acclimatising trees, grasses, &c., the seeds of which he obtained from England. His leisure he filled up with writing newspaper articles on hygiene and other subjects. He also pursued his favourite subject, chemistry, and patented a "plan for saving fuel during the process of smelting ores," which he had invented in 1838. For many years he was assayer to the Mint at Melbourne, while for

---

\* In a letter, dated October 10, 1883, and received since the above was written, Mr. Edward Davy himself says, in answer to our inquiry, "How is it that, being alive, you have never asserted your claims?"—"When the Solicitor-General passed Cooke and Wheatstone's first patent in the face of my opposition and of the grounds thereof, how could I say that he had not done rightly? Again, when my father sold the patent for so insufficient a sum, I looked upon it that all hope of pecuniary benefit to myself was gone. I might still have fought for the credit of the invention, but I *was not aware* that the documents, which you have unearthed, had been so carefully preserved; besides, being at such a distance, I should have had to carry on a controversy at a great disadvantage, with the risk of being considered an impostor. I had friends in England; but none able, if ever so willing, to defend the claim. The other party was in the midst of friends, and in possession of the field."

the past twenty-five years he has carried on a medical practice, latterly in partnership with one of his sons. In this busy colonial life he has, no doubt, found more happiness than in brooding over his disappointments. Only in one letter to his family do I find any reference to the telegraph. Writing to one of his sisters in 1841, after saying that a storm is preventing him from going to sleep, he adds :—" I shall therefore enter into some conversation with you, although, from there being no electro-telegraph, it may be five months ere my voice reaches you." Whatever be the cause, it is certain that he has never once referred to this period of his life, and, as Mr. Fahie says, he will be quite as surprised as any one at finding that his labours of forty-five years ago have now been made public.

Mr. Fahie concludes the narrative of Edward Davy's inventions and negotiations by terming it a magnificent failure, and I think no one will deny this who has read how nearly he obtained complete success. It was, however, only a failure as far as he, himself, was concerned. His labours were, in reality, most useful. His experiments in Regent's Park, his exhibition of his instrument in Exeter Hall, brought electric telegraphy before the public in a way which was done by no other person. His correspondence with, and the constant advocacy of his invention to, such men as Brunel, Fox, and Easthope forced the electric telegraph on their notice with a double force, and, no doubt, did much to cause its early adoption. I do not here enter into the question as to how far his ideas were adopted by others. It is certain that, with a strange lack of business-like foresight, he exhibited his machine before it was patented, and that his exhibition was visited by Cooke, Wheatstone, &c. Probably his work has assisted many of his successors in working out improvements ; but quite apart from this his labours were useful, and are well worthy of recognition. It is interesting to note that he spent some thousands in experimenting and making his experiments public. Mr. Fahie has shown me a letter printed in *The Electrician* (October 11, 1879) from the late Dr. Cornish, vicar of Ottery St. Mary. This letter says Edward Davy's family spent thirty thousand pounds on the

electric telegraph. I do not know whether there is a misprint here, but if the thirty be divided by ten I think the resulting three thousand would be more near the mark. It is also interesting to note that Edward Davy is still alive, and well appreciated by his fellow-townsmen in his colonial home. Almost the last paper I got from him contained an account of an entertainment given in his honour, at which, he having refused any more substantial acknowledgment, he was presented with an illuminated address in recognition of his having been for many years a magistrate and on three occasions mayor of his town, and for having for twenty-five years gratuitously held the office of medical officer of health to the district.

It is to me a satisfaction that these MSS. have come to light during his lifetime. He is now seventy-seven years of age, and for the past forty-five years his claims have been quite ignored. He, I am sure, would be the last to claim any position which was undeserved, but it cannot but be a pleasure to him to see the real value of his work recognised, and his name rescued from an unmerited oblivion, and placed in its proper position as one of the very first pioneers of electric telegraphy.

A writer in *The Exeter and Plymouth Gazette*, for September 25, 1883, supplies the following additional information :—

“ My attention having been called to the series in *The Electrician* by a recent article from the pen of the ubiquitous Harry Hems, I made inquiries of an old and respected inhabitant of Ottery (Mr. Jeffrey, solicitor), who knew the Davy family well. He says that at the end of the last century Thomas Davy, surgeon, commenced practice at Ottery St. Mary. Soon after, he married the daughter of a literary gentleman of Exeter, named Boutflower. Trade in the town of Ottery at that time was brisk. In the year 1782 a large woollen manufactory was completed, at a ruinous cost to Sir George Younge, Bart., the then lord of the manor. The manufactory was conducted by Messrs. Ball and Fowell, a daughter of the former of whom is still alive. It was

always said that Mr. Davy was of the same family as Sir Humphry Davy, who was born at Penzance in the year 1778. He also was intended for the medical profession, and served under an apothecary in order to study chemistry—a circumstance that resulted in his invention of the Davy safety lamp, the metallic bases of the alkalis and earths, and of the principles of electro-chemistry. Mr. Thomas Davy had possessions in the West Indies, and held them until his death, in the year 1852. At the end of the last century a large fire occurred in Mill Street, Ottery, in a butcher's shop occupied by a person named James. Mr. Thomas Davy became the purchaser of the ruins, and erected on the site a mansion, where he resided until his death. He was blessed with four sons and two daughters. Edward Davy (the inventor of telegraphy) was the eldest son. At an early age he showed precocity, and having his father's surgery at command, he for a time quite gave himself up to the study of chemistry, particularly electro-chemistry. He was convinced that the time would arrive when communication would be made by wire round the world. Later on in life he left Ottery for London, where he married the daughter of a London magistrate named Minshell [see p. 404]. He then again followed his old hobby, and expressed himself confident of discovering the secret of communication by telegraphy. At last he accomplished his end, and took a room in the Exeter Hall, Strand, where his instrument, not unlike a piano, was exhibited. He cut letters from a printed bill, and gummed them on to the keys. Wires were placed round the room, which he said were one mile long. Attached were a number of small jets like lamps, placed at intervals, which he instantaneously lighted through the wire. He said to his audience, 'The most extraordinary part of it is, that if I touch one of these letters it moves a corresponding letter instantaneously at the end of the wire.' A person asked if distance made any difference, and Mr. Davy replied, 'No; if I had these wires 3000 miles long, or even round the world, one could not discover the difference of time.' Strange to say, he ultimately sold his discovery and right for 600*l.*, and left for Australia. As a young man he took a great interest also in

geology, and frequently started off from Ottery to examine the hills in the district. On reaching Melbourne he pursued his study of geology, and in due time appeared an article from his pen in the Melbourne *Argus* (which by-the-by was edited by a gentleman who had been educated at the King's Grammar School, when kept by the Vicar of Ottery, Dr. Cornish), showing that he was of opinion that the country, or certain parts of it, was auriferous. This article Mr. Thomas Davy retained up to the time of his death, and often read it to his friends. Mr. Thomas Davy had an extensive practice at Ottery. He had more than an ordinary share of common sense, and was amiable and kind, particularly to the poor. For many years he studied the art of producing fat stock, and was the only person who then grew mangel-wurzel in the parish, which was called at that period by the farmers 'A gentleman's crop.' He was brother to the late—I had almost said centenarian of Topsham—James Davy, whose remarkable career is worthy of notice, and who possessed a successful business for over sixty years in a ship-building, coal, and lime trade. Although deprived of sight for a great number of years, his energy of mind and body was not impaired. He was benevolent and much respected. The only representative of Mr. Thomas Davy left in the county is Dr. Davy, of Exeter."

We make the following extract from the Melbourne *Argus*, for November 16, 1883 :—

*Royal Society of Victoria.*

The ordinary monthly meeting of the Royal Society was held on Thursday evening ; Mr. R. L. J. Ellery (president) in the chair. Mr. Ellery read the following paper describing an interesting fact in connection with the early history of the electric telegraph :—

"It is no new thing to say that the one who by intellectual process, or rational experiment, makes a discovery seldom reaps the benefit, either as regards reputation, or more substantial results. The man of science, or the patient investigator,

is nowhere in the race, as compared with the man of business, and so it often, almost always, happens that the discoverer is forgotten, while those who, ghoulishly, turn his brains to account are the only ones who reap the reward and are remembered. This is because men like Faraday, and many more, are not business men; their life is spent in inquiring of nature's forces and nature's laws, and giving the results for the benefit of mankind, and not in learning and following the more popular ways of money-making. The instance I am about to refer to is a case in point. Let us think for a moment what a mess we should be in if we were suddenly deprived of the electric telegraph, or electricity as a means of communication at a distance, and we may perhaps form some sort of an idea of what we owe to those early workers who laid the foundation-stones of this great and universal benefit. Nevertheless one, and, as it now seems likely, the first who by his discoveries made the electric telegraph a fact has been hidden among us for over thirty years, scarcely known except as a country surgeon, and certainly never till now recognised as one to whom the gratitude, if nothing else, of the whole civilised world belongs for his investigations into the applications of electricity and magnetism, which are now considered by competent authorities to have constituted those first important steps which rendered all subsequent details of the electric telegraph an easy task. From some articles in *The Electrician*, it is pretty clear that Dr. Edward Davy (who was known by some of us thirty years ago, as superintendent of the Assay Office in Melbourne, was one of the founders of the Philosophical Institute, the parent of this Royal Society, and now resides at Malmesbury, following his profession as a medical man), must be regarded in virtue of his most important discoveries, exhibitions of working models at Exeter Hall, and his invitation to carry out his electric telegraph on the Great Western line in England, the real first inventor of the electric telegraph. The history in brief seems to be this: As early as 1836 Davy conceived the possibility of an electric telegraph, and appears to have had an excellent knowledge and thorough grasp of the properties of electricity.



He had been educated for the medical profession, and took his diploma at the Royal College of Surgeons in 1828. He then seems to have taken up the business of an operative or analytical chemist, and we have heard of several chemical instruments invented or improved by him. During this time (about 1835) he seems to have made some investigations into electricity, and in 1836 the possibility of using the electric current for telegraphic purposes suggested itself to him, and he matured a method, which he patented in 1838, as already stated. Cooke and Wheatstone patented in 1837, and afterwards actually carried their needle telegraph into operation, and obtained its adoption on the railway lines of Great Britain. Davy, who had matured his plan and exhibited working models before this time, contested unsuccessfully the granting of the patent. Perhaps from the want of means, or perhaps for lack of the commercial afflatus, so often absent in scientific men, yet so essential to the substantial success of a discovery or invention, Davy failed to carry his telegraph into practical use, and eventually we hear of his having come to Australia in 1839; his connection with the early discovery of the electric telegraph was forgotten, nor does he ever seem to have in any way resuscitated the matter until his work is referred to in Mr. Fahie's papers on the early history of the electric telegraph, published lately in *The Electrician*. Although Cooke and Wheatstone succeeded, and Dr. Davy did not, this does not alter the fact that to the latter we are decidedly indebted for discoveries which eventually resulted in the perfection of both what are known as the needle and Morse systems. To those interested in this subject, I may state that copies of Dr. Davy's work and inventions can be seen in *The Electrician*, vol. xi., Nos. 8, 9, 10, and 11 of this year. There is, however, one paragraph taken from his letters and communications which is interesting and prophetic; it is in a postscript to a letter to his father, dated July 1838. Speaking of a suggestion that had been made, to the effect that Government would scarcely allow such a powerful instrument to be in the hands of individuals, he says:—

“ I know very well the French Government would not permit it except in their own hands, but though I think our Government

ought, and perhaps will eventually take it upon themselves as a branch of the Post Office ; yet I can scarcely imagine that there would be such absurd illiberality as to prohibit or appropriate it without compensation.'

"Again in 1838 Davy wrote :—

"'I cannot, however, avoid looking at the system of electrical communication between distant places, in a more enlarged way, as a system which will one of these days become an especial element in social intercourse. As railways are already doing, it will tend still further to bring remote places, in effect, near together. If the one may be said to diminish distance, the other may be said to annihilate it altogether, being instantaneous.'

"There is a ring of prescience in these words, uttered as they were forty-five years ago, before a mile of telegraph wire had been erected except the single mile he constructed himself for experimental purposes in Regent's Park ; and although, so far as is known, the idea of submarine communication was at that time scarcely dreamt of, Davy, in his 'Outline description of his improved electrical telegraph,' refers to and describes an insulated conductor or 'cable' for such a purpose. This Society will, I am sure, feel proud to know that it may rank among its founders the name of Edward Davy, the almost forgotten pioneer and inventor of the electric telegraph, and at the eleventh hour to do what honour to him it may be within its province and power to do."

Mr. Ellery intimated, amidst applause, his intention to move at next meeting that Dr. Davy be elected a life honorary member of the Society.

Professor Kernot thought a much higher honour was due to Dr. Davy, if he was really the actual first discoverer of the electric telegraph.

Mr. C. R. Blakett suggested the appointment of a sub-committee to look into the matter, and report as to the best means of recognising the scientific services of Dr. Davy.

The suggestion was adopted, the sub-committee appointed being Messrs. S. W. M'Gowan, J. Cosmo Newbery, C. R. Blakett, Professor Kernot, and Dr. Wilkie.

The following paragraph appeared in *The Electrician*, for January 12, 1884:—

*Edward Davy.*—The graphic and interesting accounts of Edward Davy's telegraphic inventions, which have appeared in these pages from the pen of Mr. J. J. Fahie, have aroused considerable interest in the colony of Victoria, Dr. Davy's adopted home. We notice that Mr. Ellery recently read a paper before the Royal Society of Victoria in which he concurred with Mr. Fahie in thinking that, if Davy had stayed in the Strand instead of emigrating to Australia in disgust, he would have succeeded in establishing his claim to be the first inventor of the electric telegraph. At the conclusion of his paper, Mr. Ellery proposed that the Society should do him such honour as lay in their power by electing him a life honorary member. The meeting, however, were of opinion that Dr. Davy deserved some still better recognition of his so long neglected genius, and appointed a sub-committee to report upon the best means of doing him public honour. We hope that our colonial kinsfolk will not be allowed to entirely show us the way in this matter. Davy lived in London, and exhibited his apparatus here long before he went to live in Australia. Who can tell how much modern telegraphy is indebted to the inventive genius of the chemist who resided at 390, Strand? Had he stayed here he would no doubt have exercised a very powerful influence on the history of the telegraph, for, as Mr. Fahie has so ably shown, he was far in advance of his contemporaries both in theory and practice. Circumstances caused him to leave us, and he was for a time forgotten. Do not let us forget how much he is deserving of honour at our hands, however—not a mere empty, formal, and official recognition of his services, but something substantial, and that may prove of benefit to the man himself in his declining years. Why not place his name on the Civil List, as has been already suggested? There are many far less deserving than Dr. Davy to be counted in this list. We feel sure that the many telegraph engineers and electricians of the present day who know how to appreciate Davy's genius will not allow their

colonial brethren to out-do them in honouring him, nor let the matter sleep for want of a little energy. It is curious to notice that Dr. Davy was not altogether fortunate in his Australian career, and that misfortune came upon him through no fault of his. It appears that Dr. Davy was Assay Master at the Melbourne Mint, from 1853 to 1855, and enjoyed a salary of 1500*l*. This was when Mr. La Trobe was governor. Dr. Davy had been specially invited to accept this post whilst occupying another similar, but less lucrative position in Adelaide. A succeeding governor, however, Sir Charles Hotham, abolished the office, giving Dr. Davy, by way of compensation, six months' salary. Here, then, was Davy once more turned adrift by Fortune's wheel. At the time that he was at Melbourne, Mr. Childers, the present Chancellor of the Exchequer, was Auditor-General there. After this Davy tried his hand at farming, with but indifferent success, and finally settled down in Malmesbury to practise his profession of surgeon. Here he gradually rose high in popular esteem, has been several times mayor, and has been prime mover in several local public works of great benefit to the town. Dr. Davy is now in his seventy-eighth year, and is not so well able to carry on his profession as in his younger days, and from various causes his practice is not so good as it used to be, consequently a grant from the Civil List would be as good a mode of honouring him as any, and we think it ought to be made."



## BIBLIOGRAPHY.

[See also Catalogue of Works in which the Sympathetic Telegraph is referred to, p. 20.]

## A.

- ABOUT, EDMOND, *Le Nez d'un Notaire*, 20  
 Addison, *Spectator*, No. 241 (1711),  
*Guardian*, No. 119 (1713), 9  
 Akenside, *The Pleasures of Imagination* (1744), 9  
 Aldini, *Essai théorique et expérimental sur le Galvanisme* (Paris, 1804), 264, 343  
 Alexander, W., *Plan and Description of the Original Electro-Magnetic Telegraph*, 448  
 Alibert, *Éloges historiques de Galvani* (Paris, 1802), 183  
*American Polytechnic Review* (1881), 263  
*Annales de Chim. et de Phys.*, 194, &c.  
*Annales Télégraphiques* (1859), 109  
 Anon [Hamilton Walker?], *Notes to Assist the Memory* (Lond., 1835), 306  
 Aristotle, *History of Animals* (ix. 37), 27, 170  
 Augustine, St., *De Civitate Dei*, 413
- B.
- Bacon, Lord, *Advancement and Proficiency of Learning*, 311  
 Bakewell, *Manual of Electricity* (1857), 274  
 Beraud, *Dissertation sur le rapport qui se trouve entre la cause des effets de l'Aiman, et celles des phénomènes de l'Électricité* (Bordeaux, 1748), 251  
 Berio, *Ephemerides of the Lecture Society, Genoa* (1872), 122  
 Birch, *History of the Royal Society*, 36  
 Blasius de Vigenere, *Les cinq premiers livres de Tite Live* (1576), 5  
 Böckmann, *Versuch über Telegraphie und Telegraphen* (1794), 98  
*Bologna Academy Transactions*, for Galvani's papers, 180  
 Bostock's *History of Galvanism*, 214, 270, 297  
 Boyle, Robert, *Experiments and Notes about the Mechanical Origin or Production of Electricity* (1675), 32  
 Brewster, Sir D., *Letters on Natural Magic*, 33  
 — *Life of Sir Isaac Newton*, 36  
 — *Edinburgh Encyclopædia*, 48  
 Browne, Sir Thos., *Pseudodoxia Epidemica* (London, 1646), 13  
 Bryant, *Transactions American Soc.*, vol. ii., 172

## C.

- Cabeus, N., *Philosophia Magnetica* (1629), 17  
 Cantu, see *Le Correspondant*  
 Cavallo, *Complete Treatise on Electricity* (1795), 98, 178  
 Cézanne, *Le Cable Transatlantique* (Paris, 1867), 122  
*Chambers's Edinburgh Journal*, 20  
 — *Papers for the People, Electric Communications* (1851), 80  
 Clark, Latimer, *Biography of Sir W. Fothergill Cooke* (*Journ. Soc. Tel. Engs.*, vol. viii. p. 374), 512  
*Commercial Magazine*. See Wedgwood  
*Commonwealth, The*, for Mr. Dick's letter on C. M., 73  
*Comptes Rendus Acad. des Sciences*, 121, &c.  
 Cooke, Sir W. F., *The Electric Telegraph, was it invented by Prof. Wheatstone?* (London, 1856-7), 513  
 "Corpusculum," *Mechanics' Mag.* Dec. 8, 1837), 345  
*Cosmos les Mondes*, 258  
*Cryptographia Frederici*, 311  
 Cumming, Prof., *On the Connection of Galvanism and Magnetism* (Camb. Phil. Soc., 1821), 281

## D.

- D'Aubigné, *Hist. Reformation*, 2  
 Davy, Hy., *Short Memoir of Edward Davy* (1883), 516  
 Desaguliers, *Dissertation concerning Electricity* (1742), 48  
 Diderot, *Collection Complète des Œuvres, &c.* (1773), 255  
*Dingler's Journal*, 320

- Dodd's *Railways, Steamers, and Telegraphs* (1867), 80  
 Donovan, *Essay on the Origin, Progress, and Present State of Galvanism* (Dublin, 1816), 266  
 Dove, *Ueber Elektrizität*, 216  
 Dubois Reymond, *Untersuchungen über thierische Elektrizität*, 187  
 Du Moncel, *Traité théorique et pratique de Télégraphie Électrique*, 317

## E.

- Electrician*, 37, 528  
*Encyclopædia Britannica*, 36, 180, 273  
*English Chronicle* (1802), 114  
 Etenaud, *La Télégraphie Électrique* (1872), 96  
 Eustathius, *Commentarii ad Homeri Iliadem*, 28  
*Exeter and Plymouth Gazette*, for E. Davy, 522

## F.

- Falconer, W., *Observations on the Knowledge of the Ancients respecting Electricity* [*Mem. Lit. and Phil. Soc. Manchester*] (1790), 28  
 Faraday's *Experimental Researches*, 174, 285, 298  
 Fechner, *Lehrbuch des Galvanismus*, 239, 303  
 Fontenelle, Julia de, *Manuel de l'Électricité*, 121  
 Forbes, Prof., *Encyclopædia Britannica*, 8th ed., 180  
 Fournier, *Le Vieux Neuf* (Paris, 1857), 11  
 Franklin, B., *Complete Works* (1806), 65-67

Frost, A. J., *Biographical Memoir of Sir Francis Ronalds* (Lond., 1880), 18, 134

## G.

Galileo, G., *Dialogus de Systemate Mundi* (Fiorenza, 1632), 11  
 Galvani (see *Bologna Academy*)  
 Gamble, Rev. J., *Essay on the Different Modes of Communication by Signals*, 103  
 Ganot, *Elementary Treatise on Physics* (Lond., 1881), 208  
 Gauss and Weber's *Resultate, &c.*, for 1837, 108  
*Gazzetta di Trento*, for Romagnosi's experiment, 259  
 Gehlen's *Journal für die Chemie und Physik*, 262  
 Gerspach, *Histoire administrative de la Télégraphie aérienne en France* (Paris, 1861), 95  
 — See *Annales Télégraphiques* (1859), 109  
 Gilbert's *Annalen der Physik*, 279, 344  
 Gilbert, Dr., *De Magnete* (1600), 30  
 Glanvill, J., *Scep̄sis Scientifica* (1665), 14  
 Gordon, Mrs., *Home Life of Sir David Brewster* (1869), 75  
 Govi, *Romagnosi e l'Elettro-Magnetismo* (Turin, 1869), 257  
 Gray, Stephen, *Phil. Trans. Roy. Soc.* (1735-6), 41  
 Guericke, Otto, *Experimenta Nova Magdeburgica* (Amstelodami, 1672), 33  
 Guerout, A., *La Lumière Électrique* (Mar. 1883), 119  
 Guyot, *Nouvelles Récitations Physiques et Mathématiques* (1769), 119

## H.

Hakewill, *An Apologie or Declaration of the Power and Providence of God in the Government of the World* (1630), 9  
 Hamel, Dr., *Historical Account of the Introduction of the Galvanic and Electro-Magnetic Telegraph into England* (1859), 105, 227  
 Hercules de Sunde, see Schwenter  
 Highton, *Electric Telegraph: its History and Progress* (1852), 107.  
 Humboldt, *Cosmos* (1849), 29

## I.

Izarn, J., *Manuel du Galvanisme* (Paris, 1805), 265

## J.

Jameson, *New Edinburgh Philosophical Journal*, 218  
 Jewitt, L., *Life of Josiah Wedgwood* (Lond., 1865), 124  
 — *Ceramic Art in Great Britain* (Lond., 1878), 124  
 Jones, *Historical Sketch of the Electric Telegraph* (New York, 1852), 160, 508  
*Journal de Paris* (1782), 85  
*Journal de Physique, &c.*, 189, &c.  
*Journal des Travaux de l'Acad. de l'Industrie Française* (March 1839), 161, 316, 491  
*Journal für Math. und Physik*, 262  
*Journal of the Society of Telegraph Engineers*, 80, 274, 512  
*Journal Télégraphique de Berne*, 168



## K.

- Kirby and Spence, *Introduction to Entomology*, 169  
 Kircher, A., *Magnes, sive de arte magnetica* (1641), 18  
 Komaroff's *La Presse Scientifique des Deux Mondes*, 317

## L.

- La Lumière Électrique* (Mar. 1883, Guerout), 119, 162  
 Lardner, *Manual of Electricity*, 27, &c.  
 La Rive, De, *Treatise on Electricity* (1853-58), 345  
 Larrey, Baron, *Clinique Chirurgicale and Bulletin de la Société Médicale d'Émulation*, 239  
*Le Correspondant* (1867), 82  
 Lehot, *Observations sur le Galvanisme et le Magnétisme* (Paris, 1806), 256  
*Le Journal des Sçavans*, 89  
*Le Mercure de France* (1782), 87  
 Leonardus, Camillus, *Speculum Lapidum* (1502), 4  
*Les Mondes* (1867), 82  
 Linguet's *Mémoires sur la Bastille*, 88  
 Livy, Blasius de Vigenere, 5

## M.

- Madrid, Gaceta de* (1796), 107  
*Magazine of Popular Science*, 328  
 Magrini, *Telegrafo Elettro - Magnetico* (Venezia, 1838), 167, 481  
 Maimbourg, *Hist. de l'Arianisme* (1686), 2  
 Marana, G. P. (or the Turkish Spy), *Letters of* (Paris, 1639), 12

- Martyn and Chambers, *The Phil. Hist. and Mem. of the Roy. Acad. of Sciences at Paris* (1742), 176  
*Mechanics' Magazine*, 148, &c.  
*Melbourne Argus*, for E. Davy, 524  
*Memorials Scientific and Literary of Andrew Crosse, the Electrician*, 137  
 Metra, *Correspondance Secrète* (1788), 87  
 "Misographos," *The Student, or the Oxford and Cambridge Miscellany* (1750), 9  
 Moigno, *Traité de Télégraphie Électrique* (Paris, 1852), 91, 101, 150  
*Monthly Magazine, The*, 107, 268  
*Morning Herald*, for 1837, 152

## N.

- Nicholson's *Journal of Natural Philosophy*, 194, &c.  
 Noad's *Manual of Electricity*, 256  
*Notes and Queries*, 32, 74, 306

## O.

- Oersted, *Recherches sur l'Identité des forces chimiques et électriques* (Paris, 1813), 271  
 O'Shaughnessy's *Electric Telegraph in British India*, 348

## P.

- Paris, *Life of Sir H. Davy*, 213  
 Parthenius, J. M., *Electricorum* (1767), 77  
*Philosophical Magazine*, 211, &c.  
*Philosophical Transactions*, 33, &c.  
 Pliny, *Nat. Hist.* xxxii. 2, 170; xxxvii. 3, 27  
 Plutarch, *Life of Timoleon*, 28

- Poggendorff's *Annalen*, &c., 282, 319
- Porta, Baptista, *Magia Naturalis* (1558), 6
- Prescott, G. B., *History, Theory, and Practice of the Electric Telegraph* (Boston, 1860), 160
- Prevost, P., *Notice de la vie et des écrits de George Louis Le Sage de Genève* (1805), 91
- Priestley, *History and Present State of Electricity* (1767), 38, &c.
- Public Characters of 1800-1801*, 89
- Q.
- Quarterly Journal of Science and the Arts* (Roy. Inst.), 263, &c.
- R.
- Recy, H., *Télégraphie Électrique* (Paris, 1838), 162
- Reid, *Telegraph in America* (New York, 1879), 98, 328
- Revista de Telegrafos* (1876), 102
- Rive, De La, see La Rive
- Robertson, *Mémoires Récréatifs Scientifiques et Anecdóticos* (Paris, 1840), 179, 187
- Roget, *Electro-Magnetism*, 281
- Romagnosi (see *Gazzetta di Trento*, and Govi)
- Ronalds, Sir F., *Catalogue of Electrical Works*, edited by A. J. Frost (London, 1880), 128
- Francis, *Descriptions of an Electrical Telegraph* (Lond. 1823), 128 (see also Frost, A. J.)
- Ronalds' MSS., 144-5
- S.
- Saavedra, *Tratado de Telegrafia* (Barcelona, 1880), 102, 220
- Sabine, R., *History and Progress of the Electric Telegraph* (London, 1869), 266, 384
- Satirist, The*, 245
- Schott, *Schola Steganographica*, 7
- Schweigger's *Journal für Chemie und Physik*, 243, 279
- Schwenter, Daniel, *Steganologia et Steganographia* (Nürnberg, 1600), 6
- Scots' Magazine* (1753), 68
- Scribonius Largus, *De Compositione Medicamentorum Medica*, 171
- Shaffner, *Telegraph Manual* (New York, 1859), 328
- Sharpe, J. R., *On the Electrical Telegraph* (*Repertory of Arts*, June 1816), 244
- Benjamin, *A Treatise on the Construction and Submersion of Deep-Sea Electric Telegraph Cables*, 245
- Silliman's *American Journal of Science*, 290, &c.
- Smith, Egerton (Editor), *The Kaleidoscope, or Literary and Scientific Mirror* (Liverpool, 1824), 146
- Smithsonian Report*, 405-11
- Sömmerring, *Der Elektrische Telegraph*, &c., 227
- Strada, F., *Prolusiones Academicæ* (Rome, 1617), 8
- Stratingh, *Iets over eenen Electro-Magnetischen Klokken-Telegraaf* 1838), 488
- Stuart, Alex., *Experiments to prove the Existence of a Fluid in the Nerves* (*Phil. Trans.*, 1732), 176
- Sturgeon's *Annals of Electricity*, 216, 328

- Sulzer, *Nouvelle Théorie des Plaisirs* (1767), 150, 178  
 Swammerdam, *Biblia Natura*, vol. ii. p. 839, 175  
 Swedenborg, *Principia Rerum Naturalium* (Dresden, 1734), 251

## T.

- Telegrapher, The* (vol. i. pp. 48, 163, New York), 160  
*Telegraphic Journal* (Nov. 15, 1875, from Strada), 9  
 Theophrastus, *De Lapidibus*, 27  
 Thomson's *Annals of Philosophy*, 246  
*Times*, 124  
 Tomlinson, *The Thunderstorm*, 28  
*Transactions of the American Society*, 172, 285  
*Transactions of the Society of Arts*, 286  
 Tyndall, J., *Address to the British Association* (1874), 16  
 — *Notes on Electricity*, 38

## V.

- Vail, *Electro-Magnetic Telegraph*, 162, 311  
 Van Mons' *Journal de Chemie* (Jan. 1803), 262, &c.

- Van Swinden, *Recueil de Mémoires sur l'Analogie, &c.*, 255  
 Voigt's *Magazin für das Neueste aus der Physik*, 96, 107  
 Vorrsmann de Heer, *Théorie de la Télégraphie Électrique* (Deventer, 1839), 150

## W.

- Watson, Dr., *An account of some experiments made by some gentlemen of the Royal Society* (1748), 61  
 Wedgwood, W. R., Letter to the *Commercial Magazine* (1846), 127  
 — R., *Book of Remembrance* (1814), 125  
 Wilson, Dr. Geo., *Elect. Tel.* (1852), 2  
 Winkler, *Thoughts on the Properties, Operations, and Causes of Electricity* (Leipsic, 1744), 59

## Y.

- Young, Arthur, *Travels in France, &c.*, 91

## Z.

- Zetzsche, *Geschichte der Elektrischen Telegraphie*, 98, &c.

## INDEX.

## A.

AIR-PUMP, inventor of, 33  
 Alarum, first suggested by Daniel Schwenter, 8  
 —, electric-bell, first proposed by a Frenchman, 87  
 —, clockwork, first employed by Sömmerring, 234  
 Alarums, E. Davy's, 397-9  
 Alexander's, William, telegraph, 448  
 Alexandre's, Jean, telegraph, 109  
 Alphabet, telegraphic, invention of, 311  
 — Gauss and Weber's, 324  
 — Mungo Ponton's, 473  
 — Schilling's, 311  
 — Steinheil's, 342  
 Amber, electrical properties of, 27-29  
 Ampère's researches, 275  
 — astatic needle, invention of, 280  
 — telegraph, 302  
 Amyot's telegraph, the first automatic printing one, 491  
 Analogies between electricity and lightning, 252  
 — — electricity and magnetism, 250-6  
 Animal electricity, 169-74  
 Anonymous (French) telegraph, 85

Astatic needle invented, 280  
 Aurora borealis and magnetism, 251  
 Authors referred to, 531  
 Axial magnet, germ of, 356

## B.

Baggs, Isham (patent 1856), 168  
 Barlow's *dictum* on the impracticability of electric telegraphs, 306  
 Battery, voltaic, 192-219  
 — the (so-called) constant, 215  
 — Leclanché, invented by E. Davy, 396  
 Beccaria, polarity of needle magnetised by electricity, 253  
 Bembo, Cardinal, origin of sympathetic telegraph, 8  
 Berton, H. M., telegraph, 121  
 Bevis, Dr., experiments with the Leyden jar, 57  
 Bibliography of the history of the electric telegraph, 531  
 Block system for railways, 407  
 Böckmann's telegraph, 98  
 Booth, Abraham, electro-magnetic telegraph, 508  
 Boyle, R., supposed first observer of electric light, 33  
 Bozulus' telegraph, 77  
 Brown, Sir T., and the sympathetic telegraph, 12

## C.

- C. M.'s telegraph, 68  
 — Who was he, Marshall or Morrison [?], 72  
 Cabeus, Nicolas, and the sympathetic telegraph, 17  
 Cable, aerial, first suggested by Salvá, 104  
 — submarine, first suggested by Salvá, 105  
 — — E. Davy's curious proposals for, 368  
 — — first ordered, 319  
 Caldani, "Revival of frogs by electric discharge," 175  
 Catalogue of books referring to sympathetic telegraph, 20  
 — of works referred to, 531  
 Cavallo's telegraph, 98  
 Chappe's telegraph, the first synchronous one, 93  
 Commutator, first employed by Schilling, 313  
 Company, the first telegraph, and prospectus, 430, 439  
 "Corpusculum's" telegraph, 477  
 — — Roman type printing, 481  
 Cotugno's experiments, 178  
 Coxe's telegraph, 246  
 Crosse, Andrew, prophesies electric telegraphs in 1816, 137  
 Cruickshank's researches, 194  
 — battery, 212  
 Cyr, Réveroni-Saint-, telegraph, 95

## D.

- Dampers, copper, principle of, 281  
 — — uses of, 283, 321, 336  
 Davy's, E., correspondence, 415  
*et seq.*

- Davy's, E., duplex telegraph, 391-395  
 — — electro-chemical telegraph, 379-91  
 — — honours to, 524, 527, 529  
 — — needle telegraphs, 349-379  
 — — memoir of, 516  
 — — MSS., 350  
 — — relay or renewer, 359, 515  
 — Sir H., experiments, 197-205  
 — — discovery of the alkalies, 273  
 De Heer's, Vosselmann, physiological telegraph, 150  
 Delambre, Report on Alexandre's telegraph, 114  
 Désaguliers introduces terms conductor and non-conductor, 48  
 — his sad death, 49  
 Dream of Elector Frederick of Saxony, 1  
 Dufay's discoveries, 46  
 Du Jardin's telegraph, 166  
 Du Verney, experiments on frogs, 175  
 Dyar, H. G., telegraph, the first chemical and recording one, 155

## E.

- Earth circuit, discovery of, 343  
 Effects of static electricity wrongly considered electro-magnetic, 262  
 Elector Frederick's dream, 1  
 Electric conduction and insulation, 41  
 — light, 33, 38  
 — — in vacuo first observed by Picard (1675), 38  
 — repulsion, discovery of, 35  
 — telegraphs. See Telegraphs

Electrical machine, Faraday's, 65  
 — — — Guericke's, 34  
 — — — improvements, 1741-42,  
 51  
 Electricity, earliest notices of, 26-  
 30  
 Electro-magnet, invention of, by  
 Sturgeon, 285  
 — magnets, Prof. J. Henry's re-  
 searches on, 286  
 —-magnetism, historical, 250  
 Electrometer, invention of, 92, 318  
 Electromotive force, how affected,  
 206-208

## F.

Fabroni's chemical theory of gal-  
 vanism, 188  
 Fabie's, J. J., duplex telegraph and  
 improved electro-magnet, 487  
 — — — letters to, 402, 467, 488  
 Faraday's researches in magneto-  
 electricity and electro-magnetism,  
 298  
 Franklin's experiments with Leyden  
 jar, 58, 64  
 — electrical battery, 65  
 — on the analogies between  
 electricity and lightning, 252  
 Franz, J., experiments with Leyden  
 jar, 57

## G.

Galileo and the sympathetic tele-  
 graph, 11  
 Galvani's experiments, 180  
 Galvanism, early instances of, 175  
 — limit of, supposed to have been  
 reached in 1818, 270  
 Galvanometer, invention of, 278  
 —, dead-beat, first constructed  
 by Schilling, 312

Galvanometer, mirror, first used by  
 Gauss and Weber, 322  
 Gauss and Weber's telegraph, the  
 first magneto-electric one, 319  
 Glanvill, Joseph, and the sympa-  
 thetic telegraph, 14  
 Gralath's experiments with Leyden  
 jar, 58  
 Gray, Stephen, experiments, 41  
 Grotthus's theory of voltaic action,  
 209

## H.

Hauksbee's experiments, 39-40  
 Henry, Prof. J., electro-magnets,  
 &c., 286  
 — — — on Morse, 495  
 — — — discovery of the relay  
 circuit, 511  
 — — — report of Smithsonian  
 Institution on, 499  
 — — — electro-magnetic tele-  
 graph, 507  
 Highton, H. (patent 1844), 168

## I.

Induction, early instances of, 45  
 — Newton's experiment, 35  
 Insulation, discovery of, 45

## K.

Kepler and the sympathetic tele-  
 graph, 11  
 Kircher and the sympathetic tele-  
 graph, 18

## L.

Larrey, Baron, on Sömmerring's  
 telegraph, 236  
 Lemonnier's experiments with Ley-  
 den jars, 60

Le Sage's telegraph, 89  
 Leyden jar, discovery of (1745), 52  
 — — — improvements in, 56-58  
 — — — experiments with, 58-67  
 — — — predicted by Stephen Gray, 54  
 — — — wonderful effects of, 55  
 Lightning and electricity first compared, 40  
 — — — conductors, invention of, 67  
 Linguet's luminous (semaphore) telegraph, 88  
 Lomond's telegraph, 91  
 Lullin's telegraph, 98  
 Luminous substances, 33

## M.

Magnetic lines of force, theory of, explained and illustrated in the 17th century, 17-18  
 — — — needle affected by aurora borealis, 251  
 Magnetism ever a fruitful source of impositions, 5  
 Magneto-electricity discovered by Faraday, 298  
 Magrini's telegraph, 481  
 "Moderator's" telegraph, 148  
 Mojon's experiment not electro-magnetic, 264  
 Mongenot's labial telegraph, 150  
 Morse, Prof. Henry on, 495  
 Musschenbröck's Leyden jar, 52

## N.

Needles (balanced) used by Dr. Gilbert in electrical experiments, 31  
 Newton's induction experiment, 35  
 — — — Sir I., letter of, 37

Nicholson, W., experiments, 193  
 Nollet, L'Abbé, experiments with Leyden jar, 59

## O.

Odier's telegraph, 79  
 Oersted's researches in electro-magnetism, 270  
 Ohm, Prof. G. S., 297  
 Ohm's laws experimentally arrived at by Prof. J. Henry, 296

## P.

Picard, electric light in vacuo, 38  
 Ponton, Mungo, telegraph, 468  
 Porta, Baptista, originated story of sympathetic telegraph, 5  
 Porter's, S., telegraph, 152  
 Potocki, Jeroslas, letter to Sömmering, 241  
 Prospectus, the first telegraph company's, 430

## R.

R. H., telegraph (1825), 151  
 Railways, block system for, 407  
 Rapidity of electric discharge (1744), 59  
 Recy, H., telegraph, the first syllabic one, 162  
 Relay, the, or renewer, 359, 366, 380, 515  
 — — —, the Brown and Allan, germ of, 357  
 Repulsion, electric, discovery of, 35  
 Retardation in buried wires predicted by Ronalds, 142  
 Reusser's telegraph, 96  
 Reversals, use of, first suggested by Salvá, 225

Richelieu, Cardinal, and the sympathetic telegraph, 12  
 Richter's experiments on *Gymnotus*, 175  
 Ritchie's telegraph, 303  
 Ritter's researches in electro-magnetism, 266  
 Romagnosi's claim to the discovery of electro-magnetism disproved, 257  
 Ronalds Catalogue, the, 128  
 — MSS., the, 144  
 — telegraph (1816), 127  
 — F., on Volta's telegraph, 80

## S.

St. Amand, T. de, telegraph (1828), 161  
 Salvá's telegraph, the first physiological one, 101  
 — — the first galvano-chemical one, 220  
 Schilling's telegraph, 307  
 Schweigger's telegraph, 243  
 — galvanometer, invention of, 278  
 Schwenter, Daniel, and the sympathetic telegraph, 6  
 Secondary battery, Ritter's, first described by Gautherot, 267  
 Severus, Bishop, and early magnetic attractions, 4  
 Sharpe's telegraph, 244  
 Smith, Egerton, telegraph, 146  
 Smithsonian Institution, report on Prof. Henry *vs* Morse, 499  
 Sömmerring's telegraph, 227  
 Static or frictional electricity, history of, 26  
 Steinheil's telegraph, 320  
 — — anecdote of, 328

Strada and the sympathetic telegraph, 8  
 Stratingh's telegraph, 486  
 Stuart's experiments on frogs, 176  
 Sturgeon, inventor of electro-magnet, 285  
 Sulphur as an electric, 34  
 Sulzer's experiments, 178  
 Swammerdam's experiment, 175

## T.

Telegraphs, Electric :—  
 1753. C. M., 68  
 1767. Bozulus, 77  
 1773. Odier, 79  
 1777. Volta, 80  
 1782. Anonymous, 85  
 1782. Le Sage, 89  
 1787. Lomond, 91  
 1790. Chappe, 93  
 1790. Réveroni-Saint-Cyr, 95  
 1794. Reusser, 96  
 1794. Bockmann, 98  
 1794-5. Lullin, 98  
 1795. Cavallo, 98  
 1795-8. Salvá, 101  
 1798 [?]. Berton, H. M., 121  
 1800-4. Salvá, Dr. F., 220  
 1802. Alexandre, 109  
 1806-14. Wedgwood, 123  
 1809-12. Sömmerring, 227  
 1811. Schweigger, 243  
 1813. Sharpe, J. R., 244  
 1816. Coxe, 246  
 1816. Ronalds, 127  
 1820. Ampère, 302  
 1824. Smith, Egerton, 146  
 1825. "Moderator," *Mechanics' Magazine*, 148  
 1825. R. H., 151  
 1825. Porter, S., 152



- Telegraphs, Electric—*continued* :—  
 1825-37. Schilling, 307  
 1826-7. Dyar, H. G., 155  
 1828. St. Amand, T. de, 161  
 1830. Ritchie, 303  
 1830. Abraham Booth, 508  
 1830. Recy, H., 162  
 1831-2. Prof. J. Henry, 507  
 1833-8. Gauss and Weber, 319  
 1836. Steinheil, 326  
 1836-9. Davy, 349  
 1836. Cooke and Wheatstone, 512  
 1837. Alexander, 448  
 1837. Du Jardin, 166  
 1837-8. Ponton, Mungo, 468  
 1837. "Corpusculum," 477  
 1837. Magrini, 481  
 1837. Stratingh, 486  
 1837. Amyot, 491  
 1839. De Heer, 150  
 Telegraph, roman type printing in  
 1832, 481  
 —, sympathetic, catalogue of  
 books referring to, 20  
 — — flesh, 19-20  
 — — needle, 1-19  
 — — snail, 20  
 Telegraphs, postal, foretold, 429  
 Telegraphing without wires, first  
 hinted at by Steinheil, 347  
 Telephone first suggested by E.  
 Davy, 395  
 Thermo-electricity discovered, 297  
 Thornthwaite, W. H., letter from,  
 on Edward Davy, 402  
 Tommasi on Romagnosi, 258  
 Torpedoes, electric, first used by  
 Schilling, 309
- V.
- Valens, Emperor, story of early  
 instance of (probably) magnetic  
 attractions, 3  
 Varley's, C. F., telegraph, 168  
 Vitreous and resinous electricity,  
 discovery of, 47  
 Volta's (so-called) telegraph (1777),  
 80  
 — discoveries, 186  
 Volta, honours to, 183  
 —, relics of, 84
- W.
- Water, composition of, first dis-  
 covered, 193  
 Watson, Wm., experiments with  
 Leyden jar, 56, 60  
 Wedgwood's telegraph (1806-14),  
 123  
 Wenckebach's telegraph, 168  
 Wheatstone, letters from, on Davy's  
 telegraph, 381, 443  
 —, Sir Chas., and the use of the  
 relay, 512-515  
 Wires, telegraphic, overhead, folly  
 of, foreseen in 1837, 318  
 Wollaston, Dr., experiments, 205
- Z.
- Zinc, amalgamated, first used, 218

LIST OF BOOKS  
RELATING TO  
ELECTRICITY, TELEGRAPHY,  
THE ELECTRIC LIGHT, &c.

PUBLISHED AND SOLD BY

E. & F. N. SPON, 16, CHARING CROSS, LONDON.

- 18mo, boards, 2s.*
- A Handbook of the Electro-Magnetic Telegraph.** By A. E. LORING, a Practical Telegrapher.
- With numerous Illustrations, 8vo, cloth, 21s.*
- Electricity and the Electric Telegraph.** By G. B. PRESCOTT.
- With numerous Illustrations, royal 8vo, cloth, 10s. 6d.*
- Electricity in Theory and Practice, or the Elements of ELECTRICAL ENGINEERING.** By Lieut. BRADLEY A. FISKE, U.S.N.
- 248 pp. and 7 Plates, 8vo, cloth, 9s.*
- Reports of the Committee on Electrical Standards appointed by the BRITISH ASSOCIATION.** Revised by Sir W. THOMSON, Dr. J. P. JOULE, Professors CLERK MAXWELL and FLEMING JENKIN. With a Report to the Royal Society on Units of Electrical Resistance, by Professor F. Jenkin. Edited by Professor FLEMING JENKIN, F.R.S.
- With Illustrations, crown 8vo, cloth, 12s. 6d.*
- Elementary Treatise on Electric Batteries.** From the French of ALFRED NIAUDET. Translated by L. M. FISHBACK.
- Oblong 8vo, cloth, 10s. 6d.*
- Handbook of Electrical Diagrams and Connections.** By C. H. DAVIS and FRANK B. RAE.
- With Illustrations, 8vo, sewed, 1s. 6d.*
- The Telephone.** A Lecture, entitled "Researches in Electro-Telephony," by Professor ALEXANDER GRAHAM BELL, delivered before the Society of Telegraph Engineers.
- Crown 8vo, cloth, 4s. 6d.*
- Elements of Construction for Electro-Magnets.** By COUNT TH. DU MONCEL, Membre de l'Institut de France. Translated from the French by C. J. WHARTON.
- 8vo, sewed, 1s.*
- Electric Lighting: its State and Progress, and its Probable INFLUENCE ON THE GAS INTERESTS.** By J. T. SPRAGUE, Mem. Soc. Tel. Eng.
- With 113 Engravings and Diagrams, crown 8vo, cloth, 7s. 6d.*
- Electricity as a Motive Power.** By COUNT TH. DU MONCEL, Membre de l'Institut de France, and FRANK GERALDY, Ingénieur des Ponts et Chaussées. Translated and edited by C. J. WHARTON, Assoc. Soc. of Telegraph Engineers and of Electricians.
- With Woodcut Illustrations, crown 8vo, cloth, 4s.*
- Useful Information on Electric Lighting.** Embodying the Rules of the Fire Risk Committee and the Electric Lighting Bill; also plain directions for the working of Electric Lamps and Dynamo-Machines. By KILLINGWORTH HEDGES, F.C.S., M. Soc. T.E., Assoc. Mem. Inst. C.E. Fourth Edition, revised and enlarged.
- 8vo, sewed, 1s.*
- The Supply of Electricity by Local Authorities.** By KILLINGWORTH HEDGES, M. Inst. M.E.
- 8vo, sewed, 1s.*
- The Electric Light for Industrial Uses.** By R. E. CROMPTON.
- 8vo, cloth, 10s. 6d.*
- Electric Lighting by Incandescence, and its Application to INTERIOR ILLUMINATION.** A Practical Treatise, with 96 Illustrations. By W. E. SAWYER.

## BOOKS ON ELECTRICITY, ETC.

- 285 pp., with numerous Diagrams and Tables, crown 8vo, cloth, 12s. 6d.  
**Electrical Tables and Formulæ for the use of Telegraph Inspectors and Operators.** Compiled by LATIMER CLARK and ROBERT SABINE.
- 18mo, cloth, 1s. 6d.  
**Practical Electrical Units popularly explained.** By JAMES SWINBURNE, late of J. N. Swan and Co., Paris, late of Brush-Swan E.L. Co., U.S.A.
- 126 pp., with 36 Illustrations, fcap. 8vo, cloth, 1s.; sewed, 6d.  
**Electro-Telegraphy. A Book for Beginners.** By FREDERICK S. BRECHET, Telegraph Engineer.
- With Portrait and Wood Engravings, 8vo, cloth, 7s. 6d.  
**Philipp Reis, Inventor of the Telephone: a Biographical Sketch,** with documentary testimony, translations of the original papers of the Inventor and contemporary publications. By SILVANUS P. THOMPSON, B.A., D.Sc., Professor of Experimental Physics in University College, Bristol.
- 8vo, sewed, 8s.; large paper, 12s. 6d.  
**Catalogue of Books and Papers relating to Electricity, Magnetism, and the Electric Telegraph, &c.** Including the Ronalds Library, compiled by Sir FRANCIS RONALDS, F.R.S., together with a Biographical Memoir of the Author. Edited by ALFRED J. FROST, Assoc. Soc. T.E., Member of the Library Association of the United Kingdom.
- 8vo, sewed, 1s.  
**Electric Lighting by Water Power.** By THOS. B. GRIERSON, Assoc. Inst. C.E.
- With 62 Illustrations, crown 8vo, cloth, 4s. 6d.  
**Practical Electric Lighting.** By A. BROMLEY HOLMES, Assoc. M. Inst. C.E.
- With numerous Diagrams and Tables, crown 8vo, cloth, 3s. 6d.  
**The Laying and Repairing of Electric Telegraph Cables.** By Capt. V. HOSKIER, Royal Danish Engineers.
- Second Edition, crown 8vo, cloth, 4s. 6d.  
**A Guide for the Electric Testing of Telegraph Cables.** By Capt. V. HOSKIER, Royal Danish Engineers.
- 8vo, sewed, 4s.  
**Journal of the Society of Telegraph Engineers and of Electricians.** Edited by Professor W. E. AVRTON, F.R.S. No. 50.
- Royal 8vo, cloth, 16s.  
**Lightning Conductors: their History, Nature, and Mode of Application.** By R. ANDERSON, F.C.S., F.G.S., Member of the Society of Telegraph Engineers.
- 8vo, cloth, 7s. 6d.  
**Lightning-Rod Conference.** Report of the Delegates from the following Societies, viz.: the Meteorological Society, the Royal Institute of British Architects, the Society of Telegraph Engineers and Electricians, the Physical Society, and co-opted Members. Edited by G. J. SYMONDS, F.R.S.
- Royal 8vo, cloth, 15s.  
**The Speaking Telephone, Electric Light, and other Electrical Inventions.** By G. B. PRESCOTT. Fully illustrated.
- Crown 8vo, cloth, 5s.  
**Practical Information for Telephonists.** By T. D. LOCKWOOD.
- 8vo, sewed, 1s.  
**Electro-Motors and their Government.** By Professors W. E. AVRTON, F.R.S., and JOHN PERRY, M.E.
- 18mo, boards, 2s.  
**Incandescent Electric Lights.** With particular reference to the Edison Lamps at the Paris Exhibition. By COUNT DU MONCEL and W. H. PREECE.

London: E. & F. N. SPON, 16, Charing Cross.  
New York: 35, Murray Street.

1884.

BOOKS RELATING  
TO  
APPLIED SCIENCE

PUBLISHED BY

E. & F. N. SPON,  
LONDON: 16, CHARING CROSS.  
NEW YORK: 35, MURRAY STREET.

---

*A Pocket-Book for Chemists, Chemical Manufacturers, Metallurgists, Dyers, Distillers, Brewers, Sugar Refiners, Photographers, Students, etc., etc.* By THOMAS BAYLEY, Assoc. R.C. Sc. Ireland, Analytical and Consulting Chemist and Assayer. Third edition, with additions, 437 pp., royal 32mo, roan, gilt edges, 5s.

SYNOPSIS OF CONTENTS:

Atomic Weights and Factors—Useful Data—Chemical Calculations—Rules for Indirect Analysis—Weights and Measures—Thermometers and Barometers—Chemical Physics—Boiling Points, etc.—Solubility of Substances—Methods of Obtaining Specific Gravity—Conversion of Hydrometers—Strength of Solutions by Specific Gravity—Analysis—Gas Analysis—Water Analysis—Qualitative Analysis and Reactions—Volumetric Analysis—Manipulation—Mineralogy—Assaying—Alcohol—Beer—Sugar—Miscellaneous Technological matter relating to Potash, Soda, Sulphuric Acid, Chlorine, Tar Products, Petroleum, Milk, Tallow, Photography, Prices, Wages, Appendix, etc., etc.

*The Mechanician: A Treatise on the Construction and Manipulation of Tools, for the use and instruction of Young Engineers and Scientific Amateurs, comprising the Arts of Blacksmithing and Forging; the Construction and Manufacture of Hand Tools, and the various Methods of Using and Grinding them; the Construction of Machine Tools, and how to work them; Machine Fitting and Erection; description of Hand and Machine Processes; Turning and Screw Cutting; principles of Constructing and details of Making and Erecting Steam Engines, and the various details of setting out work, etc., etc.* By CAMERON KNIGHT, Engineer. *Containing 1147 illustrations, and 397 pages of letter-press.* Third edition, 4to, cloth, 18s.

*On Designing Belt Gearing.* By E. J. COWLING  
WELCH, Mem. Inst. Mech. Engineers, Author of 'Designing Valve  
Gearing.' Fcap. 8vo, sewed, 6d.

*A Handbook of Formulæ, Tables, and Memoranda,  
for Architectural Surveyors and others engaged in Building.* By J. T.  
HURST, C.E. Thirteenth edition, royal 32mo, roan, 5s.

"It is no disparagement to the many excellent publications we refer to, to say that in our opinion this little pocket-book of Hurst's is the very best of them all, without any exception. It would be useless to attempt a recapitulation of the contents, for it appears to contain almost *everything* that anyone connected with building could require, and, best of all, made up in a compact form for carrying in the pocket, measuring only 5 in. by 3 in., and about  $\frac{1}{2}$  in. thick, in a limp cover. We congratulate the author on the success of his laborious and practically compiled little book, which has received unqualified and deserved praise from every professional person to whom we have shown it."—*The Dublin Builder.*

*The Cabinet Maker ;* being a Collection of the most  
approved designs in the Mediæval, Louis-Seize, and Old English styles,  
for the use of Cabinet Makers, Carvers, &c. By R. CHARLES. 96 plates,  
folio, half-bound, 10s. 6d.

*Quantity Surveying.* By J. LEANING. With 42 illus-  
trations, crown 8vo, cloth, 9s.

CONTENTS :

A complete Explanation of the London  
Practice.  
General Instructions.  
Order of Taking Off.  
Modes of Measurement of the various Trades.  
Use and Waste.  
Ventilation and Warming.  
Credits, with various Examples of Treatment.  
Abbreviations.  
Squaring the Dimensions.  
Abstracting, with Examples in illustration of  
each Trade.  
Billing.  
Examples of Preambles to each Trade.  
Form for a Bill of Quantities.  
Do. Bill of Credits.  
Do. Bill for Alternative Estimate.  
Restorations and Repairs, and Form of Bill  
Variations before Acceptance of Tender.  
Errors in a Builder's Estimate.

Schedule of Prices.  
Form of Schedule of Prices.  
Analysis of Schedule of Prices.  
Adjustment of Accounts.  
Form of a Bill of Variations.  
Remarks on Specifications.  
Prices and Valuation of Work, with  
Examples and Remarks upon each Trade.  
The Law as it affects Quantity Surveyors,  
with Law Reports.  
Taking Off after the Old Method.  
Northern Practice.  
The General Statement of the Methods  
recommended by the Manchester Society  
of Architects for taking Quantities.  
Examples of Collections.  
Examples of "Taking Off" in each Trade.  
Remarks on the Past and Present Methods  
of Estimating.

*A Practical Treatise on Heat, as applied to the  
Useful Arts ;* for the Use of Engineers, Architects, &c. By THOMAS  
BOX. With 14 plates. Third edition, crown 8vo, cloth, 12s. 6d.

*A Descriptive Treatise on Mathematical Drawing  
Instruments :* their construction, uses, qualities, selection, preservation,  
and suggestions for improvements, with hints upon Drawing and Colour-  
ing. By W. F. STANLEY, M.R.I. Fifth edition, with numerous illustrations,  
crown 8vo, cloth, 5s.

*Spons' Architects' and Builders' Pocket-Book of Prices and Memoranda.* Edited by W. YOUNG, Architect. Royal 32mo, roan, 4s. 6d. ; or cloth, red edges, 3s. 6d. *Published annually.* Eleventh edition, *Now ready.*

*Long-Span Railway Bridges,* comprising Investigations of the Comparative Theoretical and Practical Advantages of the various adopted or proposed Type Systems of Construction, with numerous Formulæ and Tables giving the weight of Iron or Steel required in Bridges from 300 feet to the limiting Spans ; to which are added similar Investigations and Tables relating to Short-span Railway Bridges. Second and revised edition. By B. BAKER, Assoc. Inst. C.E. *Plates, crown 8vo, cloth, 5s.*

*Elementary Theory and Calculation of Iron Bridges and Roofs.* By AUGUST RITTER, Ph.D., Professor at the Polytechnic School at Aix-la-Chapelle. Translated from the third German edition, by H. R. SANKEY, Capt. R.E. *With 500 illustrations, 8vo, cloth, 15s.*

*The Builder's Clerk: a Guide to the Management of a Builder's Business.* By THOMAS BALES. *Fcap. 8vo, cloth, 1s. 6d.*

*The Elementary Principles of Carpentry.* By THOMAS TREGOLD. Revised from the original edition, and partly re-written, by JOHN THOMAS HURST. Contained in 517 pages of letter-press, and *illustrated with 48 plates and 150 wood engravings.* Third edition, crown 8vo, cloth, 18s.

Section I. On the Equality and Distribution of Forces—Section II. Resistance of Timber—Section III. Construction of Floors—Section IV. Construction of Roofs—Section V. Construction of Domes and Cupolas—Section VI. Construction of Partitions—Section VII. Scaffolds, Staging, and Gantries—Section VIII. Construction of Centres for Bridges—Section IX. Cofferdams, Shoring, and Strutting—Section X. Wooden Bridges and Viaducts—Section XI. Joints, Straps, and other Fastenings—Section XII. Timber.

*Our Factories, Workshops, and Warehouses: their Sanitary and Fire-Resisting Arrangements.* By B. H. THWAITE, Assoc. Mem. Inst. C.E. *With 183 wood engravings, crown 8vo, cloth, 9s.*

*Gold: Its Occurrence and Extraction,* embracing the Geographical and Geological Distribution and the Mineralogical Characters of Gold-bearing rocks ; the peculiar features and modes of working Shallow Placers, Rivers, and Deep Leads ; Hydraulicizing ; the Reduction and Separation of Auriferous Quartz ; the treatment of complex Auriferous ores containing other metals ; a Bibliography of the subject and a Glossary of Technical and Foreign Terms. By ALFRED G. LOCK, F.R.G.S. *With numerous illustrations and maps, 1250 pp., super-royal 8vo, cloth, 2l. 12s. 6d.*

*Progressive Lessons in Applied Science.* By EDWARD SANG, F.R.S.E. Crown 8vo, cloth, each Part, 3s.

Part 1. Geometry on Paper—Part 2. Solidity, Weight, and Pressure—Part 3. Trigonometry, Vision, and Surveying Instruments.

*A Practical Treatise on Coal Mining.* By GEORGE G. ANDRÉ, F.G.S., Assoc. Inst. C.E., Member of the Society of Engineers. With 82 lithographic plates. 2 vols., royal 4to, cloth, 3l. 12s.

*Sugar Growing and Refining: a Comprehensive Treatise on the Culture of Sugar-yielding Plants, and the Manufacture, Refining, and Analysis of Cane, Beet, Maple, Milk, Palm, Sorghum, and Starch Sugars, with copious statistics of their production and commerce, and a chapter on the distillation of Rum.* By CHARLES G. WARNFORD LOCK, F.L.S., &c., and G. W. WIGNER and R. H. HARLAND, FF.C.S., FF.I.C. With 205 illustrations, 8vo, cloth, 30s.

*Spons' Information for Colonial Engineers.* Edited by J. T. HURST. Demy 8vo, sewed.

No. 1, Ceylon. By ABRAHAM DEANE, C.E. 2s. 6d.

CONTENTS:

Introductory Remarks—Natural Productions—Architecture and Engineering—Topography, Trade, and Natural History—Principal Stations—Weights and Measures, etc., etc.

No. 2. Southern Africa, including the Cape Colony, Natal, and the Dutch Republics. By HENRY HALL, F.R.G.S., F.R.C.I. With Map. 3s. 6d.

CONTENTS:

General Description of South Africa—Physical Geography with reference to Engineering Operations—Notes on Labour and Material in Cape Colony—Geological Notes on Rock Formation in South Africa—Engineering Instruments for Use in South Africa—Principal Public Works in Cape Colony: Railways, Mountain Roads and Passes, Harbour Works, Bridges, Gas Works, Irrigation and Water Supply, Lighthouses, Drainage and Sanitary Engineering, Public Buildings, Mines—Table of Woods in South Africa—Animals used for Draught Purposes—Statistical Notes—Table of Distances—Rates of Carriage, etc.

No. 3. India. By F. C. DANVERS, Assoc. Inst. C.E. With Map. 4s. 6d.

CONTENTS:

Physical Geography of India—Building Materials—Roads—Railways—Bridges—Irrigation—River Works—Harbours—Lighthouse Buildings—Native Labour—The Principal Trees of India—Money—Weights and Measures—Glossary of Indian Terms, etc.

*A Practical Treatise on Casting and Founding,* including descriptions of the modern machinery employed in the art. By N. E. SPRETSON, Engineer. Third edition, with 82 plates drawn to scale, 412 pp., demy 8vo, cloth, 18s.

*Gas Works: their Arrangement, Construction, Plant, and Machinery.* By F. COLYER, M. Inst. C.E. *With 31 folding plates,* 8vo, cloth, 24s.

*The Clerk of Works: a Vade-Mecum for all engaged in the Superintendence of Building Operations.* By G. G. HOSKINS, F.R.I.B.A. Third edition, fcap. 8vo, cloth, 1s. 6d.

*Tropical Agriculture; or, the Culture, Preparation, Commerce, and Consumption of the Principal Products of the Vegetable Kingdom, as furnishing Food, Clothing, Medicine, etc., and in their relation to the Arts and Manufactures; forming a practical treatise and Handbook of Reference for the Colonist, Manufacturer, Merchant, and Consumer, on the Cultivation, Preparation for Shipment, and Commercial Value, etc., of the various Substances obtained from Trees and Plants entering into the Husbandry of Tropical and Sub-Tropical Regions.* By P. L. SIMMONDS. Second edition, revised and improved, 515 pages, 8vo, cloth, 1l. 1s.

*American Foundry Practice: Treating of Loam, Dry Sand, and Green Sand Moulding, and containing a Practical Treatise upon the Management of Cupolas, and the Melting of Iron.* By T. D. WEST, Practical Iron Moulder and Foundry Foreman. Second edition, *with numerous illustrations,* crown 8vo, cloth, 10s. 6d.

*The Maintenance of Macadamised Roads.* By T. CODRINGTON, M.I.C.E., F.G.S., General Superintendent of County Roads for South Wales. 8vo, cloth, 6s.

*Hydraulic Steam and Hand Power Lifting and Pressing Machinery.* By FREDERICK COLYER, M. Inst. C.E., M. Inst. M.E. *With 73 plates,* 8vo, cloth, 18s.

*Pumps and Pumping Machinery.* By F. COLYER, M.I.C.E., M.I.M.E. *With 23 folding plates,* 8vo, cloth, 12s. 6d.

*The Municipal and Sanitary Engineer's Handbook.* By H. PERCY BOULNOIS, Mem. Inst. C.E., Borough Engineer, Portsmouth. *With numerous illustrations,* demy 8vo, cloth, 12s. 6d.

#### CONTENTS:

The Appointment and Duties of the Town Surveyor—Traffic—Macadamised Roadways—Steam Rolling—Road Metal and Breaking—Pitched Pavements—Asphalte—Wood Pavements—Footpaths—Kerbs and Gutters—Street Naming and Numbering—Street Lighting—Sewerage—Ventilation of Sewers—Disposal of Sewage—House Drainage—Disinfection—Gas and Water Companies, &c., Breaking up Streets—Improvement of Private Streets—Borrowing Powers—Artizans' and Labourers' Dwellings—Public Conveniences—Scavenging, including Street Cleansing—Watering and the Removing of Snow—Planting Street Trees—Deposit of Plans—Dangerous Buildings—Hoardings—Obstructions—Improving Street Lines—Cellar Openings—Public Pleasure Grounds—Cemeteries—Mortuaries—Cattle and Ordinary Markets—Public Slaughter-houses, &c.—Giving numerous Forms of Notices, Specifications, and General Information upon these and other subjects of great importance to Municipal Engineers and others engaged in Sanitary Work.



*Tables of the Principal Speeds occurring in Mechanical Engineering*, expressed in metres in a second. By P. KEERAYEFF, Chief Mechanic of the Obouhoff Steel Works, St. Petersburg; translated by SERGIUS KERN, M.E. Fcap. 8vo, sewed, 6d.

*Spons' Dictionary of Engineering, Civil, Mechanical, Military, and Naval*; with technical terms in French, German, Italian, and Spanish, 3100 pp., and nearly 8000 engravings, in super-royal 8vo, in 8 divisions, 5l. 8s. Complete in 3 vols., cloth, 5l. 5s. Bound in a superior manner, half-morocco, top edge gilt, 3 vols., 6l. 12s.

See page 15.

*A Treatise on the Origin, Progress, Prevention, and Cure of Dry Rot in Timber*; with Remarks on the Means of Preserving Wood from Destruction by Sea-Worms, Beetles, Ants, etc. By THOMAS ALLEN BRITTON, late Surveyor to the Metropolitan Board of Works, etc., etc. With 10 plates, crown 8vo, cloth, 7s. 6d.

*Metrical Tables.* By G. L. MOLESWORTH, M.I.C.E. 32mo, cloth, 1s. 6d.

CONTENTS.

General—Linear Measures—Square Measures—Cubic Measures—Measures of Capacity—Weights—Combinations—Thermometers.

*Elements of Construction for Electro-Magnets.* By Count TH. DU MONCEL, Mem. de l'Institut de France. Translated from the French by C. J. WHARTON. Crown 8vo, cloth, 4s. 6d.

*Electro-Telegraphy.* By FREDERICK S. BEECHEY, Telegraph Engineer. A Book for Beginners. Illustrated. Fcap. 8vo, sewed, 6d.

*Handrailing: by the Square Cut.* By JOHN JONES, Staircase Builder. Fourth edition, with seven plates, 8vo, cloth, 3s. 6d.

*Handrailing: by the Square Cut.* By JOHN JONES, Staircase Builder. Part Second, with eight plates, 8vo, cloth, 3s. 6d.

*Practical Electrical Units Popularly Explained*, with numerous illustrations and Remarks. By JAMES SWINBURNE, late of J. W. Swan and Co., Paris, late of Brush-Swan Electric Light Company, U.S.A. 18mo, cloth, 1s. 6d.

*Philipp Reis, Inventor of the Telephone: A Biographical Sketch.* With Documentary Testimony, Translations of the Original Papers of the Inventor, &c. By SILVANUS P. THOMPSON, B.A., Dr. Sc., Professor of Experimental Physics in University College, Bristol. With illustrations, 8vo, cloth, 7s. 6d.

*A Pocket-Book of Useful Formulæ and Memoranda for Civil and Mechanical Engineers.* By GUILFORD L. MOLESWORTH, Mem. Inst. C.E., Consulting Engineer to the Government of India for State Railways. *With numerous illustrations, 744 pp.* Twenty-first edition, revised and enlarged, 32mo, roan, 6s.

## SYNOPSIS OF CONTENTS:

Surveying, Levelling, etc.—Strength and Weight of Materials—Earthwork, Brickwork, Masonry, Arches, etc.—Struts, Columns, Beams, and Trusses—Flooring, Roofing, and Roof Trusses—Girders, Bridges, etc.—Railways and Roads—Hydraulic Formulæ—Canals, Sewers, Waterworks, Docks—Irrigation and Breakwaters—Gas, Ventilation, and Warming—Heat, Light, Colour, and Sound—Gravity: Centres, Forces, and Powers—Millwork, Teeth of Wheels, Shafting, etc.—Workshop Recipes—Sundry Machinery—Animal Power—Steam and the Steam Engine—Water-power, Water-wheels, Turbines, etc.—Wind and Windmills—Steam Navigation, Ship Building, Tonnage, etc.—Gunnery, Projectiles, etc.—Weights, Measures, and Money—Trigonometry, Conic Sections, and Curves—Telegraphy—Mensuration—Tables of Areas and Circumference, and Arcs of Circles—Logarithms, Square and Cube Roots, Powers—Reciprocals, etc.—Useful Numbers—Differential and Integral Calculus—Algebraic Signs—Telegraphic Construction and Formulæ.

*Spons' Tables and Memoranda for Engineers;* selected and arranged by J. T. HURST, C.E., Author of 'Architectural Surveyors' Handbook,' 'Hurst's Tredgold's Carpentry,' etc. Fifth edition, 64mo, roan, gilt edges, 1s.; or in cloth case, 1s. 6d.

This work is printed in a pearl type, and is so small, measuring only 2½ in. by 1½ in. by ¼ in. thick, that it may be easily carried in the waistcoat pocket.

"It is certainly an extremely rare thing for a reviewer to be called upon to notice a volume measuring but 2½ in. by 1½ in., yet these dimensions faithfully represent the size of the handy little book before us. The volume—which contains 118 printed pages, besides a few blank pages for memoranda—is, in fact, a true pocket-book, adapted for being carried in the waistcoat pocket, and containing a far greater amount and variety of information than most people would imagine could be compressed into so small a space. . . . The little volume has been compiled with considerable care and judgment, and we can cordially recommend it to our readers as a useful little pocket companion."—*Engineering.*

*Analysis, Technical Valuation, Purification and Use of Coal Gas.* By the Rev. W. R. BOWDITCH, M.A. *With wood engravings, 8vo, cloth, 12s. 6d.*

*A Practical Treatise on Natural and Artificial Concrete, its Varieties and Constructive Adaptations.* By HENRY REID, Author of the 'Science and Art of the Manufacture of Portland Cement.' New Edition, *with 59 woodcuts and 5 plates, 8vo, cloth, 15s.*

*Hydrodynamics: Treatise relative to the Testing of Water-Wheels and Machinery, with various other matters pertaining to Hydrodynamics.* By JAMES EMERSON. *With numerous illustrations, 360 pp.* Third edition, crown 8vo, cloth, 4s. 6d.

*Electricity as a Motive Power.* By Count TH. DU MONCEL, Membre de l'Institut de France, and FRANK GERALDY, Ingénieur des Ponts et Chaussées. Translated and Edited, with Additions, by C. J. WHARTON, Assoc. Soc. Tel. Eng. and Elec. *With 113 engravings and diagrams, crown 8vo, cloth, 7s. 6d.*

*The Gas Analyst's Manual.* By F. W. HARTLEY, Assoc. Inst. C.E., etc. *With numerous illustrations.* Crown 8vo, cloth, 6s.

*Gas Measurement and Gas Meter Testing.* By F. W. HARTLEY. Fourth edition, revised and extended. *Illustrated,* crown 8vo, cloth, 4s.

*The French-Polisher's Manual.* By a French-Polisher; containing Timber Staining, Washing, Matching, Improving, Painting, Imitations, Directions for Staining, Sizing, Embodying, Smoothing, Spirit Varnishing, French-Polishing, Directions for Repolishing. Third edition, royal 32mo, sewed, 6d.

*Hops, their Cultivation, Commerce, and Uses in various Countries.* By P. L. SIMMONDS. Crown 8vo, cloth, 4s. 6d.

*A Practical Treatise on the Manufacture and Distribution of Coal Gas.* By WILLIAM RICHARDS. Demy 4to, with *numerous wood engravings and 29 plates,* cloth, 28s.

SYNOPSIS OF CONTENTS :

Introduction—History of Gas Lighting—Chemistry of Gas Manufacture, by Lewis Thompson, Esq., M.R.C.S.—Coal, with Analyses, by J. Paterson, Lewis Thompson, and G. R. Hislop, Esqrs.—Retorts, Iron and Clay—Retort Setting—Hydraulic Main—Condensers—Exhausters—Washers and Scrubbers—Purifiers—Purification—History of Gas Holder—Tanks, Brick and Stone, Composite, Concrete, Cast-iron, Compound Annular Wrought-iron—Specifications—Gas Holders—Station Meter—Governor—Distribution—Mains—Gas Mathematics, or Formulæ for the Distribution of Gas, by Lewis Thompson, Esq.—Services—Consumers' Meters—Regulators—Burners—Fittings—Photometer—Carburization of Gas—Air Gas and Water Gas—Composition of Coal Gas, by Lewis Thompson, Esq.—Analyses of Gas—Influence of Atmospheric Pressure and Temperature on Gas—Residual Products—Appendix—Description of Retort Settings, Buildings, etc., etc.

*Practical Geometry, Perspective, and Engineering Drawing;* a Course of Descriptive Geometry adapted to the Requirements of the Engineering Draughtsman, including the determination of cast shadows and Isometric Projection, each chapter being followed by numerous examples; to which are added rules for Shading Shade-lining, etc., together with practical instructions as to the Lining, Colouring, Printing, and general treatment of Engineering Drawings, with a chapter on drawing Instruments. By GEORGE S. CLARKE, Capt. R.E. Second edition, *with 21 plates.* 2 vols., cloth, 10s. 6d.

*The Elements of Graphic Statics.* By Professor KARL VON OTT, translated from the German by G. S. CLARKE, Capt. R.E., Instructor in Mechanical Drawing, Royal Indian Engineering College. *With 93 illustrations,* crown 8vo, cloth, 5s.

*The Principles of Graphic Statics.* By GEORGE SYDENHAM CLARKE, Capt. Royal Engineers. *With 112 illustrations,* crown 8vo, cloth, 12s. 6d.

*The New Formula for Mean Velocity of Discharge of Rivers and Canals.* By W. R. KUTTER. Translated from articles in the 'Cultur-Ingenieur,' by LOWIS D'A. JACKSON, Assoc. Inst. C.E. 8vo, cloth, 12s. 6d.

*Practical Hydraulics; a Series of Rules and Tables for the use of Engineers, etc., etc.* By THOMAS BOX. Fifth edition, numerous plates, post 8vo, cloth, 5s.

*A Practical Treatise on the Construction of Horizontal and Vertical Waterwheels,* specially designed for the use of operative mechanics. By WILLIAM CULLEN, Millwright and Engineer. With 11 plates. Second edition, revised and enlarged, small 4to, cloth, 12s. 6d.

*Aid Book to Engineering Enterprise Abroad.* By EWING MATHESON, M. Inst. C.E. The book treats of Public Works and Engineering Enterprises in their inception and preliminary arrangement; of the different modes in which money is provided for their accomplishment; and of the economical and technical considerations by which success or failure is determined. The information necessary to the designs of Engineers is classified, as are also those particulars by which Contractors may estimate the cost of works, and Capitalists the probabilities of profit. *Illustrated*, 2 vols., 8vo, 12s. 6d. each.

*The Essential Elements of Practical Mechanics; based on the Principle of Work,* designed for Engineering Students. By OLIVER BYRNE, formerly Professor of Mathematics, College for Civil Engineers. Third edition, with 148 wood engravings, post 8vo, cloth, 7s. 6d.

#### CONTENTS:

Chap. 1. How Work is Measured by a Unit, both with and without reference to a Unit of Time—Chap. 2. The Work of Living Agents, the Influence of Friction, and introduces one of the most beautiful Laws of Motion—Chap. 3. The principles expounded in the first and second chapters are applied to the Motion of Bodies—Chap. 4. The Transmission of Work by simple Machines—Chap. 5. Useful Propositions and Rules.

*The Practical Millwright and Engineer's Ready Reckoner; or Tables for finding the diameter and power of cog-wheels, diameter, weight, and power of shafts, diameter and strength of bolts, etc.* By THOMAS DIXON. Fourth edition, 12mo, cloth, 3s.

*Breweries and Maltings: their Arrangement, Construction, Machinery, and Plant.* By G. SCAMELL, F.R.I.B.A. Second edition, revised, enlarged, and partly rewritten. By F. COLYER, M.I.C.E., M.I.M.E. With 20 plates, 8vo, cloth, 18s.

*A Practical Treatise on the Manufacture of Starch, Glucose, Starch-Sugar, and Dextrine,* based on the German of L. Von Wagner, Professor in the Royal Technical School, Buda Pesth, and other authorities. By JULIUS FRANKEL; edited by ROBERT HUTTER, proprietor of the Philadelphia Starch Works. With 58 illustrations, 344 pp., 8vo, cloth, 18s.

*A Practical Treatise on Mill-gearing, Wheels, Shafts, Riggers, etc.*; for the use of Engineers. By THOMAS BOX. Third edition, with 11 plates. Crown 8vo, cloth, 7s. 6d.

*Mining Machinery: a Descriptive Treatise on the Machinery, Tools, and other Appliances used in Mining.* By G. G. ANDRÉ, F.G.S., Assoc. Inst. C.E., Mem. of the Society of Engineers. Royal 4to, uniform with the Author's Treatise on Coal Mining, containing 182 plates, accurately drawn to scale, with descriptive text, in 2 vols., cloth, 3l. 12s.

CONTENTS :

Machinery for Prospecting, Excavating, Hauling, and Hoisting—Ventilation—Pumping—Treatment of Mineral Products, including Gold and Silver, Copper, Tin, and Lead, Iron, Coal, Sulphur, China Clay, Brick Earth, etc.

*Tables for Setting out Curves for Railways, Canals, Roads, etc.*, varying from a radius of five chains to three miles. By A. KENNEDY and R. W. HACKWOOD. Illustrated, 32mo, cloth, 2s. 6d.

*The Science and Art of the Manufacture of Portland Cement*, with observations on some of its constructive applications. With 66 illustrations. By HENRY REID, C.E., Author of 'A Practical Treatise on Concrete,' etc., etc. 8vo, cloth, 18s.

*The Draughtsman's Handbook of Plan and Map Drawing*; including instructions for the preparation of Engineering, Architectural, and Mechanical Drawings. With numerous illustrations in the text, and 33 plates (15 printed in colours). By G. G. ANDRÉ, F.G.S., Assoc. Inst. C.E. 4to, cloth, 9s.

CONTENTS :

The Drawing Office and its Furnishings—Geometrical Problems—Lines, Dots, and their Combinations—Colours, Shading, Lettering, Bordering, and North Points—Scales—Plotting—Civil Engineers' and Surveyors' Plans—Map Drawing—Mechanical and Architectural Drawing—Copying and Reducing Trigonometrical Formulæ, etc., etc.

*The Boiler-maker's and Iron Ship-builder's Companion*, comprising a series of original and carefully calculated tables, of the utmost utility to persons interested in the iron trades. By JAMES FODEN, author of 'Mechanical Tables,' etc. Second edition revised, with illustrations, crown 8vo, cloth, 5s.

*Rock Blasting: a Practical Treatise on the means employed in Blasting Rocks for Industrial Purposes.* By G. G. ANDRÉ, F.G.S., Assoc. Inst. C.E. With 56 illustrations and 12 plates, 8vo, cloth, 10s. 6d.

*Surcharged and different Forms of Retaining Walls.* By J. S. TATE. Illustrated, 8vo, sewed, 2s.

*A Treatise on Ropemaking as practised in public and private Rope-yards*, with a Description of the Manufacture, Rules, Tables of Weights, etc., adapted to the Trade, Shipping, Mining, Railways, Builders, etc. By R. CHAPMAN, formerly foreman to Messrs. Huddart and Co., Limehouse, and late Master Ropemaker to H.M. Dockyard, Deptford. Second edition, 12mo, cloth, 3s.

*Laxton's Builders' and Contractors' Tables*; for the use of Engineers, Architects, Surveyors, Builders, Land Agents, and others. Bricklayer, containing 22 tables, with nearly 30,000 calculations. 4to, cloth, 5s.

*Laxton's Builders' and Contractors' Tables. Excavator, Earth, Land, Water, and Gas*, containing 53 tables, with nearly 24,000 calculations. 4to, cloth, 5s.

*Sanitary Engineering: a Guide to the Construction of Works of Sewerage and House Drainage*, with Tables for facilitating the calculations of the Engineer. By BALDWIN LATHAM, C.E., M. Inst. C.E., F.G.S., F.M.S., Past-President of the Society of Engineers. Second edition, with numerous plates and woodcuts, 8vo, cloth, 1l. 10s.

*Screw Cutting Tables for Engineers and Machinists*, giving the values of the different trains of Wheels required to produce Screws of any pitch, calculated by Lord Lindsay, M.P., F.R.S., F.R.A.S., etc. Cloth, oblong, 2s.

*Screw Cutting Tables*, for the use of Mechanical Engineers, showing the proper arrangement of Wheels for cutting the Threads of Screws of any required pitch, with a Table for making the Universal Gas-pipe Threads and Taps. By W. A. MARTIN, Engineer. Second edition, oblong, cloth, 1s., or sewed, 6d.

*A Treatise on a Practical Method of Designing Slide-Valve Gears by Simple Geometrical Construction*, based upon the principles enunciated in Euclid's Elements, and comprising the various forms of Plain Slide-Valve and Expansion Gearing; together with Stephenson's, Gooch's, and Allan's Link-Motions, as applied either to reversing or to variable expansion combinations. By EDWARD J. COWLING WELCH, Memb. Inst. Mechanical Engineers. Crown 8vo, cloth, 6s.

*Cleaning and Scouring: a Manual for Dyers, Laundresses, and for Domestic Use*. By S. CHRISTOPHER. 18mo, sewed, 6d.

*A Handbook of House Sanitation*; for the use of all persons seeking a Healthy Home. A reprint of those portions of Mr. Bailey-Denton's Lectures on Sanitary Engineering, given before the School of Military Engineering, which related to the "Dwelling," enlarged and revised by his Son, E. F. BAILEY-DENTON, C.E., B.A. With 140 illustrations, 8vo, cloth, 8s. 6d.

*A Glossary of Terms used in Coal Mining.* By WILLIAM STUKELEY GRESLEY, Assoc. Mem. Inst. C.E., F.G.S., Member of the North of England Institute of Mining Engineers. *Illustrated with numerous woodcuts and diagrams*, crown 8vo, cloth, 5s.

*A Pocket-Book for Boiler Makers and Steam Users*, comprising a variety of useful information for Employer and Workman, Government Inspectors, Board of Trade Surveyors, Engineers in charge of Works and Slips, Foremen of Manufactories, and the general Steam-using Public. By MAURICE JOHN SEXTON. Second edition, royal 32mo, roan, gilt edges, 5s.

*The Strains upon Bridge Girders and Roof Trusses*, including the Warren, Lattice, Trellis, Bowstring, and other Forms of Girders, the Curved Roof, and Simple and Compound Trusses. By THOS. CARGILL, C.E.B.A.T., C.D., Assoc. Inst. C.E., Member of the Society of Engineers. *With 64 illustrations, drawn and worked out to scale*, 8vo, cloth, 12s. 6d.

*A Practical Treatise on the Steam Engine*, containing Plans and Arrangements of Details for Fixed Steam Engines, with Essays on the Principles involved in Design and Construction. By ARTHUR RIGG, Engineer, Member of the Society of Engineers and of the Royal Institution of Great Britain. Demy 4to, *copiously illustrated with woodcuts and 96 plates*, in one Volume, half-bound morocco, 2l. 2s.; or cheaper edition, cloth, 25s.

This work is not, in any sense, an elementary treatise, or history of the steam engine, but is intended to describe examples of Fixed Steam Engines without entering into the wide domain of locomotive or marine practice. To this end illustrations will be given of the most recent arrangements of Horizontal, Vertical, Beam, Pumping, Winding, Portable, Semi-portable, Corliss, Allen, Compound, and other similar Engines, by the most eminent Firms in Great Britain and America. The laws relating to the action and precautions to be observed in the construction of the various details, such as Cylinders, Pistons, Piston-rods, Connecting-rods, Cross-heads, Motion-blocks, Eccentrics, Simple, Expansion, Balanced, and Equilibrium Slide-valves, and Valve-gearing will be minutely dealt with. In this connection will be found articles upon the Velocity of Reciprocating Parts and the Mode of Applying the Indicator, Heat and Expansion of Steam Governors, and the like. It is the writer's desire to draw illustrations from every possible source, and give only those rules that present practice deems correct.

*Barlow's Tables of Squares, Cubes, Square Roots, Cube Roots, Reciprocals of all Integer Numbers up to 10,000.* Post 8vo, cloth, 6s.

*Canus (M.) Treatise on the Teeth of Wheels*, demonstrating the best forms which can be given to them for the purposes of Machinery, such as Mill-work and Clock-work, and the art of finding their numbers. Translated from the French, with details of the present practice of Millwrights, Engine Makers, and other Machinists, by ISAAC HAWKINS. Third edition, *with 18 plates*, 8vo, cloth, 5s.

*A Practical Treatise on the Science of Land and Engineering Surveying, Levelling, Estimating Quantities, etc.*, with a general description of the several Instruments required for Surveying, Levelling, Plotting, etc. By H. S. MERRETT. Third edition, 41 plates with illustrations and tables, royal 8vo, cloth, 12s. 6d.

PRINCIPAL CONTENTS :

Part 1. Introduction and the Principles of Geometry. Part 2. Land Surveying; comprising General Observations—The Chain—Offsets Surveying by the Chain only—Surveying Hilly Ground—To Survey an Estate or Parish by the Chain only—Surveying with the Theodolite—Mining and Town Surveying—Railroad Surveying—Mapping—Division and Laying out of Land—Observations on Enclosures—Plane Trigonometry. Part 3. Levelling—Simple and Compound Levelling—The Level Book—Parliamentary Plan and Section—Levelling with a Theodolite—Gradients—Wooden Curves—To Lay out a Railway Curve—Setting out Widths. Part 4. Calculating Quantities generally for Estimates—Cuttings and Embankments—Tunnels—Brickwork—Ironwork—Timber Measuring. Part 5. Description and Use of Instruments in Surveying and Plotting—The Improved Dumpy Level—Troughton's Level—The Prismatic Compass—Proportional Compass—Box Sextant—Vernier—Pantagraph—Merrett's Improved Quadrant—Improved Computation Scale—The Diagonal Scale—Straight Edge and Sector. Part 6. Logarithms of Numbers—Logarithmic Sines and Co-Sines, Tangents and Co-Tangents—Natural Sines and Co-Sines—Tables for Earthwork, for Setting out Curves, and for various Calculations, etc., etc., etc.

*Saws: the History, Development, Action, Classification, and Comparison of Saws of all kinds.* By ROBERT GRIMSHAW. With 220 illustrations, 4to, cloth, 12s. 6d.

*A Supplement to the above; containing additional practical matter, more especially relating to the forms of Saw Teeth for special material and conditions, and to the behaviour of Saws under particular conditions.* With 120 illustrations, cloth, 9s.

*A Guide for the Electric Testing of Telegraph Cables.* By Capt. V. HOSKIER, Royal Danish Engineers. With illustrations, second edition, crown 8vo, cloth, 4s. 6d.

*Laying and Repairing Electric Telegraph Cables.* By Capt. V. HOSKIER, Royal Danish Engineers. Crown 8vo, cloth, 3s. 6d.

*A Pocket-Book of Practical Rules for the Proportions of Modern Engines and Boilers for Land and Marine purposes.* By N. P. BURGH. Seventh edition, royal 32mo, roan, 4s. 6d.

*Table of Logarithms of the Natural Numbers, from 1 to 108,000.* By CHARLES BABBAGE, Esq., M.A. Stereotyped edition, royal 8vo, cloth, 7s. 6d.

To ensure the correctness of these Tables of Logarithms, they were compared with Callet's, Vega's, Hutton's, Briggs', Gardiner's, and Taylor's Tables of Logarithms, and carefully read by nine different readers; and further, to remove any possibility of an error remaining, the stereotyped sheets were hung up in the Hall at Cambridge University, and a reward offered to anyone who could find an inaccuracy. So correct are these Tables, that since their first issue in 1827 no error has been discovered.



*The Steam Engine considered as a Heat Engine: a Treatise on the Theory of the Steam Engine, illustrated by Diagrams, Tables, and Examples from Practice.* By JAS. H. COTTERILL, M.A., F.R.S., Professor of Applied Mechanics in the Royal Naval College, 8vo, cloth, 12s. 6d.

*The Practice of Hand Turning in Wood, Ivory, Shell, etc., with Instructions for Turning such Work in Metal as may be required in the Practice of Turning in Wood, Ivory, etc.; also an Appendix on Ornamental Turning. (A book for beginners.)* By FRANCIS CAMPIN. Third edition, *with wood engravings*, crown 8vo, cloth, 6s.

CONTENTS :

On Lathes—Turning Tools—Turning Wood—Drilling—Screw Cutting—Miscellaneous Apparatus and Processes—Turning Particular Forms—Staining—Polishing—Spinning Metals—Materials—Ornamental Turning, etc.

*Health and Comfort in House Building, or Ventilation with Warm Air by Self-Acting Suction Power*, with Review of the mode of Calculating the Draught in Hot-Air Flues, and with some actual Experiments. By J. DRYSDALE, M.D., and J. W. HAYWARD, M.D. Second edition, with Supplement, *with plates*, demy 8vo, cloth, 7s. 6d.

*Treatise on Watchwork, Past and Present.* By the Rev. H. L. NELTHROPP, M.A., F.S.A. *With 32 illustrations*, crown 8vo, cloth, 6s. 6d.

CONTENTS :

Definitions of Words and Terms used in Watchwork—Tools—Time—Historical Summary—On Calculations of the Numbers for Wheels and Pinions; their Proportional Sizes, Trains, etc.—Of Dial Wheels, or Motion Work—Length of Time of Going without Winding up—The Verge—The Horizontal—The Duplex—The Lever—The Chronometer—Repeating Watches—Keyless Watches—The Pendulum, or Spiral Spring—Compensation—Jewelling of Pivot Holes—Clerkenwell—Fallacies of the Trade—Incapacity of Workmen—How to Choose and Use a Watch, etc.

*Notes in Mechanical Engineering.* Compiled principally for the use of the Students attending the Classes on this subject at the City of London College. By HENRY ADAMS, Mem. Inst. M.E., Mem. Inst. C.E., Mem. Soc. of Engineers. Crown 8vo, cloth, 2s. 6d.

*Algebra Self-Taught.* By W. P. HIGGS, M.A., D.Sc., LL.D., Assoc. Inst. C.E., Author of 'A Handbook of the Differential Calculus,' etc. Second edition, crown 8vo, cloth, 2s. 6d.

CONTENTS :

Symbols and the Signs of Operation—The Equation and the Unknown Quantity—Positive and Negative Quantities—Multiplication—Involution—Exponents—Negative Exponents—Roots, and the Use of Exponents as Logarithms—Logarithms—Tables of Logarithms and Proportionate Parts—Transformation of System of Logarithms—Common Uses of Common Logarithms—Compound Multiplication and the Binomial Theorem—Division, Fractions, and Ratio—Continued Proportion—The Series and the Summation of the Series—Limit of Series—Square and Cube Roots—Equations—List of Formulæ, etc.

## RECENTLY PUBLISHED.

In super-royal 8vo, 1168 pp., with 2400 illustrations, in 3 Divisions, cloth, price 13s. 6d. each; or 1 vol., cloth, 2l.; or half-morocco, 2l. 8s.

# A SUPPLEMENT

TO

## SPONS' DICTIONARY OF ENGINEERING,

Civil, Mechanical, Military, and Naval.

EDITED BY ERNEST SPON, MEMB. SOC. ENGINEERS.

THE success which has attended the publication of 'SPONS' DICTIONARY OF ENGINEERING' has encouraged the Publishers to use every effort tending to keep the work up to the standard of existing professional knowledge. As the Book has now been some years before the public without addition or revision, there are many subjects of importance which, of necessity, are either not included in its pages, or have been treated somewhat less fully than their present importance demands. With the object, therefore, of remedying these omissions, this Supplement is now being issued. Each subject in it is treated in a thoroughly comprehensive way; but, of course, without repeating the information already included in the body of the work.

The new matter comprises articles upon

Abacus, Counters, Speed Indicators, and Slide Rule.	Coal Mining.	Lighthouses, Buoys, and Beacons.
Agricultural Implements and Machinery.	Coal Cutting Machines.	Machine Tools.
Air Compressors.	Coke Ovens. Copper.	Materials of Construction.
Animal Charcoal Machinery.	Docks. Drainage.	Meters.
Antimony.	Dredging Machinery.	Ores, Machinery and Processes employed to Dress.
Axles and Axle-boxes.	Dynamo - Electric and Magneto-Electric Machines.	Piers.
Barn Machinery.	Dynamometers.	Pile Driving.
Belts and Belting.	Electrical Engineering, Telegraphy, Electric Lighting and its practical details, Telephones	Pneumatic Transmission.
Blasting. Boilers.	Engines, Varieties of.	Pumps.
Brakes.	Explosives. Fans.	Pyrometers.
Brick Machinery.	Founding, Moulding and the practical work of the Foundry.	Road Locomotives
Bridges.	Gas, Manufacture of.	Rock Drills.
Cages for Mines.	Hammers, Steam and other Power.	Rolling Stock.
Calculus, Differential and Integral.	Heat. Horse Power.	Sanitary Engineering.
Canals.	Hydraulics.	Shafting.
Carpentry.	Hydro-geology.	Steel.
Cast Iron.	Indicators. Iron.	Steam Navy.
Cement, Concrete, Limes, and Mortar.	Lifts, Hoists, and Elevators.	Stone Machinery.
Chimney Shafts.		Tramways.
Coal Cleansing and Washing.		Well Sinking.

*The Steam*

Treatise  
Tables,  
F.R.S.,  
8vo, clc

*The Practical*

etc., with  
in the  
Ornament  
Third Edition

On Lathes—  
Apparatus and  
—Materials—O

*Health and*

tion with  
mode of  
Experiment  
Second Edition

*Treatise*

Rev. H.  
8vo, cloth

Definitions of  
ary—On Calculus  
Trains, etc.—Of  
up—The Vortex—  
Watches—Keyhole  
Pivot Holes—Clock  
and Use a Watch

*Notes in*

pecially for  
the City  
Memorials

*Algebra*

D.Sc., LL  
ential Calculus

Symbols and  
Positive and Negative  
nents—Roots,  
and Proportion  
Common Logarithm  
Fractions, and  
Limit of Series

NOW COMPLETE  
With nearly 1500 illustrations, in super-royal  
Divisions 1 to 4, 13s. 6d. each; Division 5, 17s. 6d.

SPONS' ENCYCLO  
OF THE  
INDUSTRIAL ARTS, MANUFACTURES  
PRODUCTS.

EDITED BY C. G. WARNFORD

Among the more important of the subjects  
following:—

- Acids, 207 pp. 220 figs.
- Alcohol, 23 pp. 16 figs.
- Alcoholic Liquors, 13 pp.
- Alkalies, 89 pp. 78 figs.
- Alloys, 10 pp.
- Asphalt, 10 pp.
- Beverages, 89 pp. 29 figs.
- Blacks, 10 pp.
- Bleaching Powder, 15 pp.
- Bleaching, 51 pp. 48 figs.
- Candles, 18 pp. 9 figs.
- Carbon Bisulphide, 10 pp.
- Celluloid, 9 pp.
- Cements, 10 pp.
- Coal-tar Products, 44 pp. 14 figs.
- Cotton, 8 pp.
- Coffee, 32 pp. 13 figs.
- Cork, 8 pp. 17 figs.
- Cotton Manufactures, 62 pp. 57 figs.
- Drugs, 38 pp.
- Dyeing and Calico Printing, 28 pp. 9 figs.
- Dye-stuffs, 16 pp.
- Electro Metallurgy, 13 pp.
- Explosives, 22 pp. 33 figs.
- Fabrics, 92 pp. 70 figs.
- Fine cloths, 10 pp. 21 figs.
- Food Preservation, 8 pp.
- Fruit, 8 pp.
- Fur, 5 pp.
- Gas, Coal, 8 pp.
- Gems, 10 pp.
- Glass, 45 pp. 77 figs.
- Graphite, 7 pp.
- Hair, 7 pp.
- Hair Manufactures, 10 pp.
- Hats, 26 pp. 26 figs.
- Honey, 10 pp.
- Hops, 10 pp.
- Horn, 10 pp.
- Ice, 10 pp. 14 figs.
- Indiarubber Manufactures, 23 pp. 17 figs.
- Ink, 17 pp.
- Ivory, 10 pp.
- Jute Manufactures, 11 pp. 11 figs.
- Knitted Fabrics—Hosiery, 15 pp. 13 figs.
- Lace, 13 pp. 9 figs.
- Leather, 28 pp. 31 figs.
- Linen Manufactures, 16 pp. 6 figs.
- Manures, 21 pp. 30 figs.
- Matches, 17 pp. 38 figs.
- Mordants, 13 pp.
- Narcotics, 47 pp.
- Nuts, 10 pp.
- Oils and Fatty Substances, 125 pp.
- Paint, 10 pp.
- Paper, 26 pp. 23 figs.
- Paraffin, 8 pp. 6 figs.
- Pearl and Coral, 8 pp.
- Perfumes, 10 pp.

London: E. & F. N. SPON, 16,  
New York: 35, Murray St

COMPLE

in super-royal 4  
1721

ENCYCLI

FACTURES

OBJECTS.

NEW YORK:

at the sale

[Faint, illegible text, likely bleed-through from the reverse side of the page]



UNIVERSITY OF MICHIGAN



3 9015 01195 8314



