

UNITED STATES PATENT AND TRADEMARK OFFICE

---

BEFORE THE PATENT TRIAL AND APPEAL BOARD

---

APPLE INC.  
Petitioner,

v.

UNILOC 2017 LLC,  
Patent Owner.

---

Case IPR2019-00700  
Patent 8,406,116 B2

---

Before SALLY C. MEDLEY, JEFFREY S. SMITH, and  
JOHN F. HORVATH, *Administrative Patent Judges*.

MEDLEY, *Administrative Patent Judge*.

DECISION  
Granting Institution of *Inter Partes* Review  
*35 U.S.C. § 314*

## I. INTRODUCTION

Apple Inc. (“Petitioner”) filed a Petition for *inter partes* review of claims 1–20 of U.S. Patent No. 8,406,116 B2 (Ex. 1001, “the ’116 patent”). Paper 1 (“Pet.”). Uniloc 2017 LLC (“Patent Owner”) filed a Preliminary Response. Paper 6 (“Prelim. Resp.”). Institution of an *inter partes* review is authorized by statute when “the information presented in the petition . . . and any response . . . shows that there is a reasonable likelihood that the petitioner would prevail with respect to at least 1 of the claims challenged in the petition.” 35 U.S.C. § 314(a). Upon consideration of the Petition and Preliminary Response, we conclude the information presented shows that there is a reasonable likelihood that Petitioner would prevail in establishing the unpatentability of at least one of claims 1–20 of the ’116 patent under 35 U.S.C. § 103(a).

### A. Related Matters

Petitioner and Patent Owner identify *Uniloc USA, Inc., et al. v. Apple Inc.*, Case No. 1:18-cv-00166-LY (W.D. Tex.) as related to the issues presented in this proceeding. Pet. 1; Paper 4, 2.

Petitioner additionally filed proceedings challenging related patents belonging to Patent Owner: IPR2019-00701 (U.S. Patent No. 8,018,877 B2) and IPR2019-00702 (U.S. Patent No. 7,969,925 B2). Pet. 1–2.

### B. The ’116 Patent

The ’116 patent is directed to methods and a server-based architecture for establishing data exchange between multiple mobile devices. Ex. 1001, Abstract, 1:23–27. According to the Specification, several instant messaging (“IM”) paradigms have been developed to take advantage of the growing IM market. *Id.* at 1:31–65. However, each of those paradigms are

limited by system compatibility (*id.* at 1:39–44), or the failure to allow for real-time communication between more than two mobile devices. *Id.* at 1:66–2:5. Accordingly, the invention addresses these problems by creating (1) a session-based IM architecture and (2) data transfer techniques for establishing data exchange between multiple mobile devices. *Id.* at 2:22–25.

An example of a digital mobile network system is illustrated in Figure 1, reproduced below:

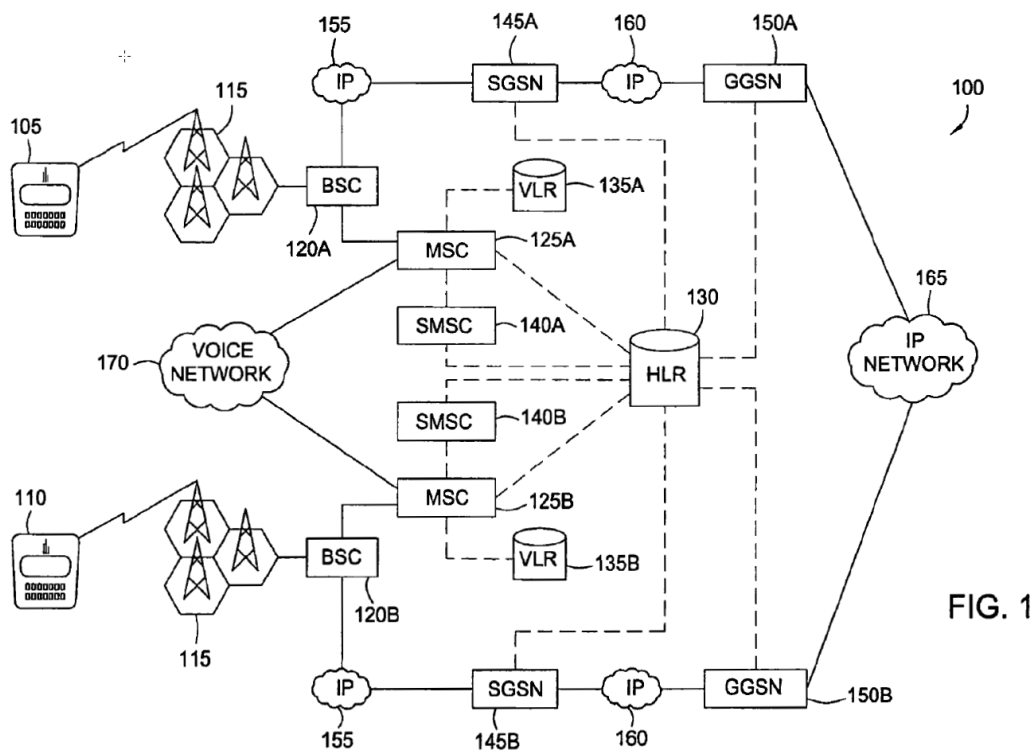

FIG. 1

Figure 1 is a diagram of a Global System for Mobile communications (GSM) mobile networking system 100 including a first mobile device 105 and a second mobile device 110. *Id.* at 2:64–3:5. As disclosed in the Specification, each of the mobile devices 105 and 110 includes a Subscriber Information Module (SIM) card that contains unique identification information that enables the GSM system 100 to locate the mobile devices within the network and route data to them. *Id.* at 3:1–5. The Specification further discloses that the GSM system 100 supports a page-mode messaging

service, such as Short Message Service (SMS), that relies upon the underlying GSM mechanisms to resolve routing information in order to locate destination mobile devices. *Id.* at 3:42–46; *see also id.* at 3:57–4:4 (describing a typical transmission of an SMS text message from the initiating mobile device 105 to the receiving mobile device 110).

Generally, the invention initiates data exchange between multiple mobile devices by first, receiving at a server, a request from the initiating mobile device to allocate a session identifier to use for data exchange. *Id.* at 2:25–40. Once the session identifier has been allocated, the server transmits the session identifier to the initiating mobile device, whereupon the initiating mobile device communicates the session identifier to the participating mobile device. *Id.* Once the initiating mobile device and participating mobile device have the session identifier, the session identifier is used to establish a connection at the server, whereby data exchange is facilitated. *Id.*

Figure 2, reproduced below, illustrates a flow chart depicting one embodiment of a server-based architecture in accordance with the present invention:

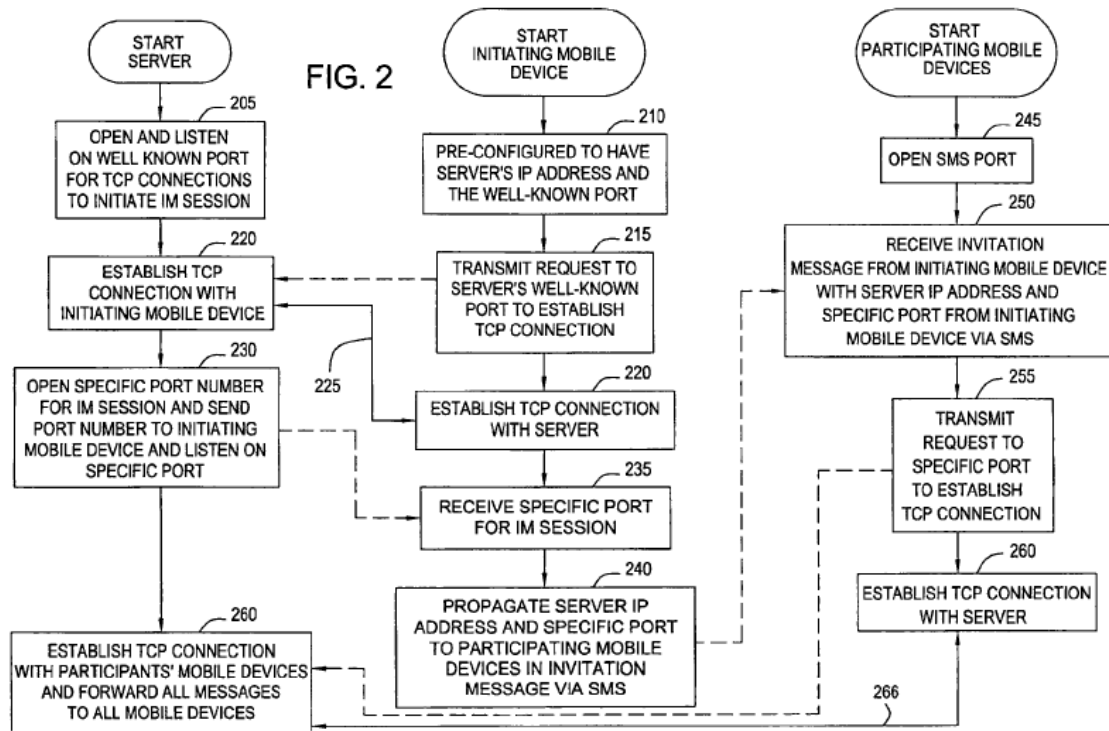

In Figure 2, the server requires a publically accessible network address, and as an initial step, the server must be open and listening for mobile device connection requests on a well-known port. *Id.* at 4:40–51. After receiving a connection request from an initiating mobile device, the server establishes a connection with the initiating mobile device 220. *Id.* at 4:60–63. The server also opens and allocates a specific network port number for the IM session and transmits this information to the initiating mobile device 230. *Id.* at 4:64–66. Initiating mobile device 230 sends the server's network address and port number in an invitation message to other mobile devices through a page-mode messaging service such as SMS. *Id.* at 5:3–9. The invited mobile devices can use this information to request a server connection in the event they wish to join the IM session. *Id.* at 5:16–21. As illustrated in box 260, the server can establish connections with mobile devices requesting participation in the IM session, and monitors all connections in addition to

# Explore Litigation Insights

Docket Alarm provides insights to develop a more informed litigation strategy and the peace of mind of knowing you're on top of things.

## Real-Time Litigation Alerts



Keep your litigation team up-to-date with **real-time alerts** and advanced team management tools built for the enterprise, all while greatly reducing PACER spend.

Our comprehensive service means we can handle Federal, State, and Administrative courts across the country.

## Advanced Docket Research



With over 230 million records, Docket Alarm's cloud-native docket research platform finds what other services can't. Coverage includes Federal, State, plus PTAB, TTAB, ITC and NLRB decisions, all in one place.

Identify arguments that have been successful in the past with full text, pinpoint searching. Link to case law cited within any court document via Fastcase.

## Analytics At Your Fingertips



Learn what happened the last time a particular judge, opposing counsel or company faced cases similar to yours.

Advanced out-of-the-box PTAB and TTAB analytics are always at your fingertips.

## API

Docket Alarm offers a powerful API (application programming interface) to developers that want to integrate case filings into their apps.

## LAW FIRMS

Build custom dashboards for your attorneys and clients with live data direct from the court.

Automate many repetitive legal tasks like conflict checks, document management, and marketing.

## FINANCIAL INSTITUTIONS

Litigation and bankruptcy checks for companies and debtors.

## E-DISCOVERY AND LEGAL VENDORS

Sync your system to PACER to automate legal marketing.