

Review

# Heterogeneous Catalysis on Metal Oxides

Jacques C. Védrine 

Laboratoire de Réactivité de Surface, Université P. & M. Curie, Sorbonne Université, UMR-CNRS 7197,  
4 Place Jussieu, F-75252 Paris, France; jacques.vedrine@upmc.fr; Tel.: +33-1-442-75560

Received: 8 October 2017; Accepted: 27 October 2017; Published: 10 November 2017

**Abstract:** This review article contains a reminder of the fundamentals of heterogeneous catalysis and a description of the main domains of heterogeneous catalysis and main families of metal oxide catalysts, which cover acid-base reactions, selective partial oxidation reactions, total oxidation reactions, depollution, biomass conversion, green chemistry and photocatalysis. Metal oxide catalysts are essential components in most refining and petrochemical processes. These catalysts are also critical to improving environmental quality. This paper attempts to review the major current industrial applications of supported and unsupported metal oxide catalysts. Viewpoints for understanding the catalysts' action are given, while applications and several case studies from academia and industry are given. Emphases are on catalyst description from synthesis to reaction conditions, on main industrial applications in the different domains and on views for the future, mainly regulated by environmental issues. Following a review of the major types of metal oxide catalysts and the processes that use these catalysts, this paper considers current and prospective major applications, where recent advances in the science of metal oxide catalysts have major economic and environmental impacts.

**Keywords:** metal oxide catalysts; heterogeneous catalysis; main catalytic reactions; main catalytic processes

## 1. Introduction to Catalysis

Catalysis is an important domain of chemistry [1–3]. Berzelius first used the word “*catalysis*” in 1836, taken from the Greek word “καταλεινν” (=loose down, dissolve) by analogy to the word “*analysis*” in order to rationalise well-known experimental observations such as wine and beer fermentation, soap and sulfuric acid (oil of vitriol) synthesis, starch transformation to sugar by acids, decomposition of  $H_2O_2$  by metals, ethanol oxidation to acetic acid on Pt, etc. By definition, catalysis is a process by which a reaction rate is enhanced by a small amount of the so-called catalyst, which supposedly does not undergo any change during the reaction, at variance with surface or stoichiometric reactions. However, as any manager of industrial plants knows, this is a very optimistic definition as real catalysts change in structure, activity and selectivity with time on stream (activation step) and deactivate more or less rapidly. Some 60 years after Berzelius, Oswald established the kinetic nature of this phenomenon and gave in 1895 the definition: “*a catalyst is a substance that changes the rate of a chemical reaction without itself appearing in the products*”. According to IUPAC (1976), a catalyst is a substance that, being present in small proportions, increases the rate of attainment of chemical equilibrium without itself undergoing chemical change.

It has been recognised that the catalyst acts by reducing the energy necessary to proceed along the reaction pathway, i.e., the activation energy  $E_a$  that needs to be surmounted to yield products. This activation energy is the energy required to overcome the reaction barrier and determines how fast a reaction occurs. The lower the activation barrier, the faster the reaction will be. Note that the thermodynamics of the reaction remains unchanged under catalyst action and that the main effect is that the catalyst influences the reaction rate.

Heterogeneous catalysis (gas or liquid phase and solid catalyst) proceeds via adsorption of one or two reactant molecule(s) on the solid surface, enhancing the reactant(s) concentration on the surface

and favouring its (their) activation. The first step of the reaction is thus the reactant(s) adsorption, whereas the reaction energy includes the activation barrier energies of adsorbed reactants ( $A_{\text{ads}}$ ), of adsorbed intermediates ( $I_{\text{ads}}$ ) and of desorption of products ( $P_{\text{ads}}$ ). In other words, the degree of catalytic efficiency gained in following a given path is governed by the energetics of the various intermediates, which encompass adsorbed reactant, the activation energy required to convert the bound reactant into a surface intermediate and finally to a product and its desorption.

Catalysis plays a prominent role in modern life. The majority of actual industrial chemical processes, involving the manufacturing of commodity-, petro-, pharmaceutical- and fine-chemicals, clean fuels, etc., as well as pollution abatement technologies, have a common catalytic origin. It is well recognised that 85–90% of industrial chemical processes involve at least one catalytic step. The main objectives of using a catalyst are to get *high activity*, i.e., high conversion of reactants and overall *high selectivity* to a desired product, the latter property avoiding or limiting separation/purification procedure, which involves important steps to take into account, particularly for economical and overall environmental issues.

Solid catalysts are classified as (i) conductors, (metals and alloys); (ii) semiconductors (oxides and sulphides); and (iii) insulators (metal oxides and solid acids or bases, including heteropolyacids, natural clays, silica–alumina and zeolites). Oxidation reactions are catalysed by oxides, while desulphurisation reactions occur on a sulphide catalyst. Insulator oxides catalyse dehydration, and acid/base solids act in processes with carbocationic/carbanionic intermediates. These features have led to the idea that there is a kind of compatibility between the catalyst and the reactant molecules. We will discuss this point when mentioning the structure sensitivity of catalytic reactions on metal oxides and describing some active sites (vide infra).

The major domains of heterogeneous catalysis, applied industrially, concern:

- Oil refining, energy and transport,
- Bulk chemicals,
- Polymers & materials and detergents & textiles,
- Fine chemicals, pharmaceutical & medical chemicals and food & feed,
- Plant design/engineering and realisation, catalyst design, subsequent development of catalysts and of catalytic processes,
- Commercial production of catalysts in sufficient quantities,
- Monitoring and control of chemical reactions and plant operations,
- Environmental issues.

## 2. Introduction to Metal Oxide Catalysts

Among the different fields of heterogeneous catalysis, catalysis by metal oxides is one of the most important, as it covers the majority of processes and of catalyst families used industrially, such as silica, alumina, clays, zeolites,  $\text{TiO}_2$ ,  $\text{ZnO}$ ,  $\text{ZrO}_2$ , porous and mesoporous metal oxides, polyoxometallates (POMs) of Keggin or Dawson type, the phosphates family (e.g., VPO,  $\text{FePO}_4$ , silica phosphoric acid (SPA)), multicomponent mixed oxides (molybdates, antimonates, tungstates,  $\text{MoVTe}(\text{Sb})\text{Nb-O}$ , etc.), perovskites, hexaaluminates, etc.

Metal oxides became prominent in the mid-1950s when they were found to effectively catalyse a wide variety of reactions, in particular oxidation and acid-base reactions. They are involved in many petrochemicals, intermediates, fine and pharmaceutical chemicals and biomass transformation reactions. They are also the basis for metallic (mono- or pluri-metallic) catalysts, for hydrodesulphurisation catalysts ( $\text{CoMoO}_4$ -,  $\text{NiMoO}_4$ -,  $\text{NiWO}_4$ -based), for  $\text{deNO}_x$ ,  $\text{deSO}_x$ , and bulk single or mixed metal oxide catalysts. The main catalytic domains cover oxidation (selective or total), acid and base catalyses, photocatalysis, depollution and biomass conversion, as described below.

This paper, being devoted to gas–solid heterogeneous catalysis, considers that the reaction occurs at the interface of two media, namely the solid catalyst and the medium of the reactants and products,

and thus involves fluid-phase transport of reactants to and products away from the catalyst surface. In heterogeneous catalysis the catalysts are in the form of powders, pellets or extrudates, in order to permit the reactant flow to cross the full catalytic bed in the reactor. For model catalysts, films or single crystals may also be considered.

Metal oxides [4,5] constitute a class of inorganic materials that have peculiar and various properties and applications as sensors, catalysts, fuel cells, etc. Oxide surfaces terminate by oxide  $O^{2-}$  anions, as their size is much larger than that of  $M^{n+}$  cations. It follows that the symmetry and coordination of  $M^{n+}$  cations are lost at the surface. Moreover, the surface of an oxide may contain different types of defects and environments (kinks, steps, terraces), which play a determining role in the catalytic phenomenon [6,7]. This surface unsaturation is usually compensated for by a reaction with water vapour, leading to the formation of surface hydroxyls according to:  $O^{2-} + H_2O \rightarrow 2OH^-$ . OH groups are conjugated acids of lattice oxygen ions  $O^{2-}$ , which are strong bases and conjugated bases of water molecules.

Among the solid state of metal oxides [8], important parameters or features act on catalytic properties. One may distinguish *point and extended defect structures*, the atomic composition and structure of a crystalline phase, and *electronic defects*, which correspond to the probability that an electron occupies an energy state, given by the Fermi–Dirac function:  $F(E) = n_e/N = 1/(\exp[(E - E_F)/RT])$ , where  $n_e$  is the number of electrons,  $N$  is the number of available energy states, and  $E_F$  is the Fermi level energy. In an *intrinsic* semiconductor, the number of electrons in the conduction band equals the number of holes in the valence band and is given by:  $n = n_e = n_h = n_0 \exp(-E_G/2kT)$ , where  $n_0$  is constant and  $E_G$  is the energy gap. Given that most oxides have a large band gap and often high contents of impurities, most electronic defects are *extrinsic*. *Extrinsic defects* can introduce carriers into localised energy levels within the band gap and, in such cases, are electrically active. An *electronic defect* in an energy level just below the conduction band edge is considered a donor as it may give electrons to the conduction band and increase the *n*-type conductivity. For instance, when a P atom of +5 oxidation state is added to silicon in silica where Si is at +4 oxidation state, the additional electron for charge compensation introduces a donor state (exciting the electron necessitates  $E_D$  rather than  $E_G$ ), while introducing a Ga ion at +3 oxidation state creates a hole in the valence band and can accept an electron, increasing the *p*-type conductivity. For a donor-doped material, the total number of the charge carrier equals:  $n_{total} = n_e(\text{dopant}) + n_e(\text{intrinsic}) + n_h(\text{intrinsic}) = n_{0D} \exp(-E_D/kT) + 2n_0 \exp(-E_G/2kT)$ . This aspect is illustrated in Figure 1.

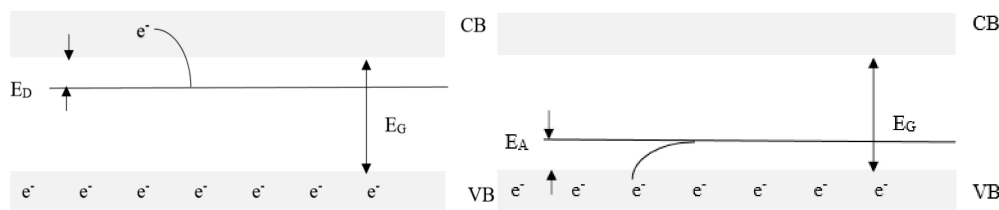

**Figure 1.** Creation of a donor band below the conduction band CB (**left**) (exciting the electron necessitates  $E_D$ ) and acceptor band (exciting the electron necessitates  $E_A$ ) above the valence band VB (**right**) upon doping.  $E_G$  = energy gap.

As heterogeneous catalysis occurs at the interface of the two media, the fluid-phase transport of reactants to and of products away from the catalyst has to be considered. In the case of solid metal oxide catalysts, solid-phase transport of defects, oxide anions and electronic conductivity should also be taken into consideration. Important properties of a metal oxide, such as electrical conductivity, lattice oxygen anions' mobility, atoms/ions' diffusion acting on sintering or phase separation, catalytic activity, melting point and various optical properties, depend on the presence of defects vs. an ideal ionic crystal. There are different types of defects: *electrons and positive holes*, excitons, *vacant lattice sites* (designated V), interstitial atoms, impurity atoms at interstitial or substitution location, dislocations and stacking faults. The subscript denotes the site that the defect occupies (lattice atom site or interstitial atom), the dot • denotes a positive charge, and x represents neutrality.

*Point defects* are missing, substituted, or interstitial ions. They are electronically charged and can be intrinsic (thermally generated in a crystal) or extrinsic (impurity or dopant). The most common *point defects* are Schottky-type, i.e., vacant cationic or anionic lattice site, or Frenkel-type, i.e., cations or anions displaced to interstitial sites. One also has *electronic defects* (electrons  $e^-$  and electron holes  $h^\bullet$  influencing electric, ionic and protonic conductivities) and *non-stoichiometry* in oxides, such as perovskites with an unfilled 3d electron shell and cation and lattice oxygen anion deficiency or excess.

Single or complex metal oxides based on the first transition series present a wide variety of *non-stoichiometric* phenomena, which originate from the unfilled 3d electron shell. For instance, Fe sites can be vacant in FeO of rocksalt framework ( $Fe_{1-x}O$  with  $0.05 < x < 0.18$ ). In  $ABO_3$  perovskite oxides, non-stoichiometry comes from a cation deficiency in A or B sites ( $A_xWO_3$ , A being an alkali ion) or oxygen anions excess. Cation A has a great influence on electrical properties. For instance,  $WO_3$  is an insulator, while  $A_xWO_3$  is a semiconductor at low  $x$  and metallic at high  $x$ . Oxygen-deficient perovskites have attracted much attention because of their oxygen storage ability and their redox properties, quite useful for total oxidation reactions. In fully oxidised  $CaMnO_{3-\delta}$  and  $CaFeO_{3-\delta}$  perovskites, Mn and Fe are at +4 oxidation state and  $\delta = 0$ , the material can accommodate up to 17% oxygen vacancies without losing its structure. The  $Sr_{1-x}La_xCo_{1-y}Fe_yO_{3-\delta}$  series, with brownmillerite-type oxygen defects, exhibits high electronic/oxygen ion mobility. In some perovskites a small oxygen excess can be accommodated by the formation of cation vacancies at A- or B-sites, leaving the oxygen sub-lattice intact. *Electronic defects* may be created upon reduction and oxidation of metal cations at different oxygen partial pressures ( $p_{O_2}$ ). At low  $p_{O_2}$ , the material loses oxygen, which generates electrons, enhancing the n-type conductivity, according to:  $O_0 \leftrightarrow (1/2) O_2 + V_O^{\bullet\bullet} + 2e^-$ . At high  $p_{O_2}$ , oxygen is incorporated into an oxygen vacancy and takes two electrons from the valence band, leading to holes contributing to the p-type conduction, according to  $(1/2) O_2 + V_O^{\bullet\bullet} \leftrightarrow O_0 + 2h^\bullet$ .

A consequence of the trapping of *electronic defects* is that the solid becomes insulating at low temperatures. Defect associations between oxygen vacancies and acceptor dopants are observed in  $Y-ZrO_2$ , where  $V_O^{\bullet\bullet}$  are trapped by  $Y_{Zr}^\bullet$  defects leading to a drastic decrease in oxide ion conductivity. Protonic defects, associated with acceptor dopants, limit protonic conduction in metal oxides. As all metal oxides contain impurities, the defect mechanism of "pure" oxides is similar to that of doped oxides. For instance, strontium titanate,  $SrTiO_3$ , has a similar defect chemistry to acceptor-doped  $SrTiO_3$ , because the impurities are ions at lower oxidation states such as  $Fe^{3+}$ ,  $Al^{3+}$ ,  $Mg^{2+}$ ,  $Na^+$ , etc., and their concentrations, typically ca.  $10^2$ – $10^3$  ppm, are sufficient to dominate the defect chemistry, especially at high  $p_{O_2}$ . All these aspects should be taken into account when considering the reaction mechanisms and kinetics on metal oxide catalysts, for instance in selective or total oxidation reactions on mixed metal oxides, where electrons and oxygen anions mobilities and lattice oxygen diffusion or storage capacity are important, for instance in a redox catalytic oxidation reaction. Lattice defects can lead to an electron transfer from the solid toward an adsorbed molecule (anionic chemisorption) or, by contrast, from the adsorbed species toward the solid (cationic chemisorption) in the case of non-stoichiometric oxides or of oxides doped with an ion of different valence. In the first case and for n-type semi-conduction, one observes a decrease in conductivity and the reverse for semi-conductors of p-type, while in the second case, conductivity increases for n-type semiconductors and decreases for p-type semiconductors.

The development of descriptors that may correlate the activity of catalysts and their physical properties is an important goal in catalysis. For instance, it has been shown [9] that the apparent activation energy for propene oxidation to acrolein over scheelite-structured, multicomponent, mixed metal oxides ( $Bi_3FeMo_2O_{12}$ ,  $Bi_2Mo_{2.5}W_{0.5}O_{12}$ ,  $Bi_{1-x/3}V_{1-x}Mo_xO_4$ , with  $0 \leq x \leq 1$ ) is related to the band gap of the catalyst measured at reaction temperature, as supported by theoretical calculations.

As we have seen above, catalysis starts with chemisorption, which should be not too strong to permit intermediate formation, and the intermediate desorption not too weak to permit adsorbed species to be activated, which is known as Sabatier's principle. Later, Taylor suggested [10] that activation energy was a key factor during the adsorption stage. He has also suggested that preferential adsorption on a catalyst

surface should take place at those atoms or ensemble of atoms, depending on the reaction and reactant size, situated at the peaks, fissures, kinks, edges, etc., of a crystallite rather than on flat surfaces. The notion of *active sites* or *active centres* was then suggested to be the locus of catalytic conversion.

However, depending on the reactant molecule size and reaction, more than one surface atom may be involved in the reaction. This is what was defined for metals by Boudart as a structure-sensitive reaction [11,12]. In the case of metal oxides, the active sites are often composed of surface ensembles of atoms to permit the reaction to occur. For instance, for oxidation reactions where both the reactant molecule and the gaseous oxygen have to be activated, the surface active site should be large enough to accommodate the reactant molecule and the oxygen from the lattice to diffuse through the solid catalyst to permit oxidation. This diffusion should be fast enough to renew lattice oxygen anions, leaving the surface with the product in a Mars and van Krevelen mechanism but not too high to avoid over-oxidation to CO<sub>2</sub> [13]. This is illustrated in Figures 2 and 3 for butane oxidation to maleic anhydride on a vanadyl pyrophosphate catalyst, designated as a VPO catalyst [14,15], and corresponds to the structure sensitivity of metal oxide for selective oxidation reactions, as demonstrated by Volta [16] for MoO<sub>3</sub> and extended to other metal oxides [17,18].

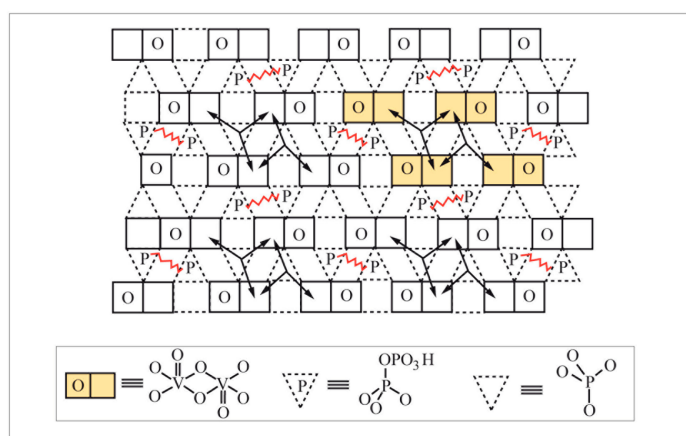

**Figure 2.** Site isolation by structure and composition: schematic of (VO)<sub>2</sub>P<sub>2</sub>O<sub>7</sub> surface structure. Facile exchange of surface oxygens exists within domains (represented by arrows), but not between domains. Site isolation established between domains by picket fence of pyrophosphate groups posing oxygen diffusion barriers. Schematic representation of a surface structure of a type of polytype of (VO)<sub>2</sub>P<sub>2</sub>O<sub>7</sub>. The arrows represent the facile pathways for surface oxygen mobility. This illustrates the site isolation principle by surface P<sub>2</sub>O<sub>7</sub> entities groups that constitute a barrier to oxygen diffusion. Reproduced with permission from [13]. Copyright Elsevier, 2014.

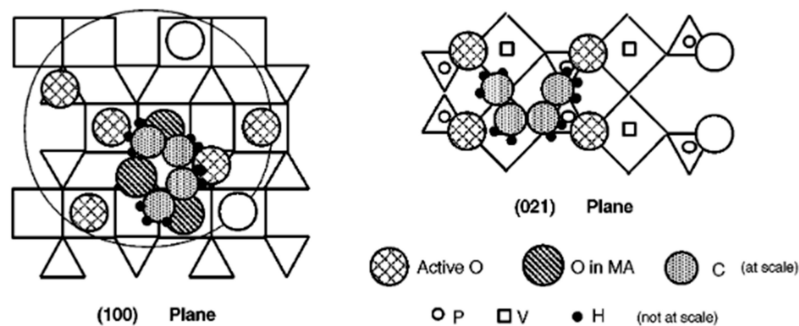

**Figure 3.** Adsorption of n-butane on (100) and (021) (VO)<sub>2</sub>P<sub>2</sub>O<sub>7</sub>. Anchoring of butane on (100) and one possible way of adsorption of butane on (021). Medium shaded and small black circles are C and H, respectively (carbon, oxygens and lattice at scale). Reproduced with permission from [14]. Copyright Springer, 2000.

# Explore Litigation Insights

Docket Alarm provides insights to develop a more informed litigation strategy and the peace of mind of knowing you're on top of things.

## Real-Time Litigation Alerts



Keep your litigation team up-to-date with **real-time alerts** and advanced team management tools built for the enterprise, all while greatly reducing PACER spend.

Our comprehensive service means we can handle Federal, State, and Administrative courts across the country.

## Advanced Docket Research



With over 230 million records, Docket Alarm's cloud-native docket research platform finds what other services can't. Coverage includes Federal, State, plus PTAB, TTAB, ITC and NLRB decisions, all in one place.

Identify arguments that have been successful in the past with full text, pinpoint searching. Link to case law cited within any court document via Fastcase.

## Analytics At Your Fingertips



Learn what happened the last time a particular judge, opposing counsel or company faced cases similar to yours.

Advanced out-of-the-box PTAB and TTAB analytics are always at your fingertips.

## API

Docket Alarm offers a powerful API (application programming interface) to developers that want to integrate case filings into their apps.

## LAW FIRMS

Build custom dashboards for your attorneys and clients with live data direct from the court.

Automate many repetitive legal tasks like conflict checks, document management, and marketing.

## FINANCIAL INSTITUTIONS

Litigation and bankruptcy checks for companies and debtors.

## E-DISCOVERY AND LEGAL VENDORS

Sync your system to PACER to automate legal marketing.