

(19) World Intellectual Property Organization
International Bureau



(43) International Publication Date
4 November 2010 (04.11.2010)

(10) International Publication Number
WO 2010/126504 A1

(51) International Patent Classification:
G06K 9/00 (2006.01)

(74) Agents: KUO, Chun-Liang et al.; Hewlett-Packard Company, Intellectual Property Administration, P.O. Box 272400 Mail Stop 35, Fort Collins, CO 80527-2400 (US).

(21) International Application Number:
PCT/US2009/042157

(81) Designated States (unless otherwise indicated, for every kind of national protection available): AE, AG, AL, AM, AO, AT, AU, AZ, BA, BB, BG, BH, BR, BW, BY, BZ, CA, CH, CN, CO, CR, CU, CZ, DE, DK, DM, DO, DZ, EC, EE, EG, ES, FI, GB, GD, GE, GH, GM, GT, HN, HR, HU, ID, IL, IN, IS, JP, KE, KG, KM, KN, KP, KR, KZ, LA, LC, LK, LR, LS, LT, LU, LY, MA, MD, ME, MG, MK, MN, MW, MX, MY, MZ, NA, NG, NI, NO, NZ, OM, PG, PH, PL, PT, RO, RS, RU, SC, SD, SE, SG, SK, SL, SM, ST, SV, SY, TJ, TM, TN, TR, TT, TZ, UA, UG, US, UZ, VC, VN, ZA, ZM, ZW.

(22) International Filing Date:
29 April 2009 (29.04.2009)

(25) Filing Language: English

(26) Publication Language: English

(71) Applicant (for all designated States except US): HEWLETT-PACKARD DEVELOPMENT COMPANY, L.P. [US/US]; 11445 Compaq Center Drive West, Houston, TX 77070 (US).

(72) Inventors: and

(75) Inventors/Applicants (for US only): GAGNERAUD, Eric [FR/US]; 20555 Tomball Parkway Houston, Houston, TX 77070 (US). AIMARD, Alexis [FR/US]; 20555 Tomball Parkway Houston, Houston, TX 77070 (US).

(84) Designated States (unless otherwise indicated, for every kind of regional protection available): ARIPO (BW, GH, GM, KE, LS, MW, MZ, NA, SD, SL, SZ, TZ, UG, ZM, ZW), Eurasian (AM, AZ, BY, KG, KZ, MD, RU, TJ, TM), European (AT, BE, BG, CH, CY, CZ, DE, DK, EE,

[Continued on next page]

(54) Title: FINGERPRINT SCANNER

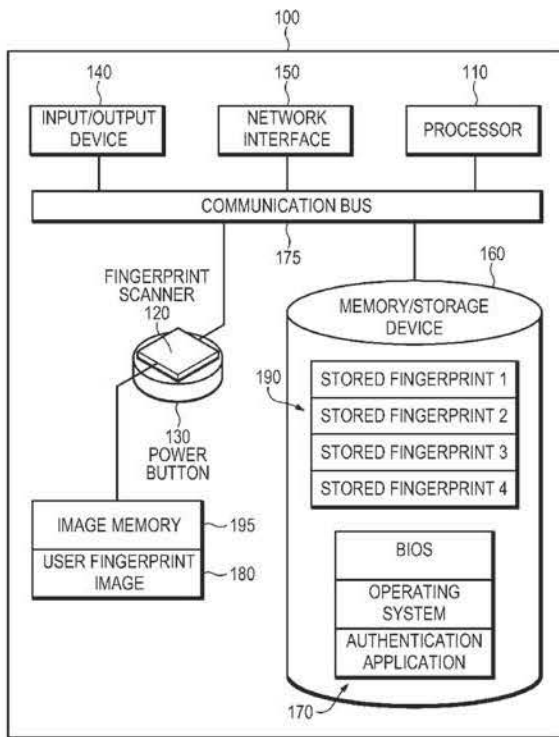

Figure 1

(57) Abstract: A machine including a processor, a power button, a fingerprint scanner coupled on the power button, and an authentication application executable by the processor for comparing a user fingerprint image with a stored fingerprint image.

WO 2010/126504 A1

Apple and Samsung Ex. 1006

Apple Inc., Samsung Electronics Co., Ltd. and



ES, FI, FR, GB, GR, HR, HU, IE, IS, IT, LT, LU, LV,
MC, MK, MT, NL, NO, PL, PT, RO, SE, SI, SK, TR),
OAPI (BF, BJ, CF, CG, CI, CM, GA, GN, GQ, GW, ML,
MR, NE, SN, TD, TG).

— as to applicant's entitlement to apply for and be granted
a patent (Rule 4.17(ii))

Published:

— with international search report (Art. 21(3))

Declarations under Rule 4.17:

— as to the identity of the inventor (Rule 4.17(i))

FINGERPRINT SCANNER

BACKGROUND

[0001] When powering on a machine such as a computing device, a user presses a power button switch on the machine. After the machine receives power, hardware and software components of the machine are loaded. The user gains access to the machine by logging into the machine with a registered password using an input device, such as a mouse or keyboard.

[0002] BRIEF DESCRIPTION OF THE DRAWINGS

[0003] Various features and advantages of the disclosed embodiments will be apparent from the detailed description which follows, taken in conjunction with the accompanying drawings, which together illustrate, by way of example, features of the disclosed embodiments.

[0004] Figure 1 illustrates a block diagram of a machine with a fingerprint scanner according to an embodiment of the invention.

[0005] Figure 2 illustrates a device having a fingerprint scanner on a power button and coupled to additional components according to an embodiment of the invention.

[0006] Figure 3 illustrates a laptop that is powered on when a fingerprint scanner detects a user according to an embodiment of the invention.

[0007] Figure 4 illustrates a fingerprint scanner on a power button and a status indicator positioned on a lid of a laptop according to an embodiment of the invention.

[0008] Figure 5 illustrates a fingerprint scanner on a power button and a status indicator positioned on a base of a laptop according to an embodiment of the invention.

[0009] Figure 6 illustrates timelines of a fingerprint scanner scanning a fingerprint, a machine powering on, and a lid of the machine unlocking according to an embodiment of the invention.

[0010] Figure 7 is a flow chart illustrating a method for authenticating a user according to an embodiment of the invention.

[0011] Figure 8 is a flow chart illustrating a method for authenticating a user according to another embodiment of the invention.

[0012] DETAILED DESCRIPTION

[0013] Figure 1 illustrates a block diagram of a machine 100 with a fingerprint scanner 120 according to an embodiment of the invention. In one embodiment, the machine 100 is a desktop, a laptop, a server, and/or any device that includes a fingerprint scanner 120. As illustrated in Figure 1, the machine 100 includes a processor 110, a fingerprint scanner 120 coupled to a power button 130, an input/output device 140, a network interface 150, a storage device 160, an authentication application 170, and a communication bus 175 for the machine 100 and/or one or more components of the machine 100 to communicate with one another. In other embodiments, the machine 100 includes additional components and/or is coupled to additional components in addition to and/or in lieu of those noted above and illustrated in Figure 1.

[0014] As noted above, the machine 100 includes a processor 110. The processor 110 receives and executes instructions for various components and/or applications of the machine 100, such as a fingerprint scanner 120 and an authentication application 170. A fingerprint scanner 120 is an optical device that scans an image of a user's fingerprint when the fingerprint scanner detects the user. In one embodiment, the fingerprint scanner 120 is disposed on an exterior of the machine 100, such as a lid of a laptop. In one embodiment, the fingerprint scanner 120 detects a user when the user touches or presses the fingerprint scanner 120 with a finger. In other embodiments, the fingerprint scanner 120 detects the user when the user's finger is within proximity of the fingerprint scanner 120. Additionally, the fingerprint scanner 120 is coupled to at least one power source (Figure 2) on the machine 100 and receives power while the machine 100 is powered off.

[0015] For the purposes of this application, the machine 100 is powered on when a BIOS and an operating system of the machine 100 have been loaded. Additionally, powering on the machine 100 is a process that includes, but is not limited to, loading the BIOS and the operating system on the machine 100. Once the operating system has finished loading, the process of powering on the machine 100 is complete and the machine 100 is powered on. Additionally, the machine 100 is powered off when the machine 100 is not powered on and is not in the process of powering on. While the machine 100 is powered off, the fingerprint scanner 120 receives power while other components of the machine 100 do not receive power.

[0016] When a user touches the fingerprint scanner 120 with a finger, an optical device on the fingerprint scanner 120 begins to scan an image of the user's fingerprint. Further, when the fingerprint scanner 120 has finished scanning the user's fingerprint, a user fingerprint image 180 is created and stored as an image file. In one embodiment, the user fingerprint image 180 is stored on an image memory 195 included in the fingerprint scanner 120. In another embodiment, the user fingerprint image 180 is stored on a storage device 160 accessible to the machine 100. The image memory 195 is memory directly coupled to and included in the fingerprint scanner 120. In some

Explore Litigation Insights

Docket Alarm provides insights to develop a more informed litigation strategy and the peace of mind of knowing you're on top of things.

Real-Time Litigation Alerts



Keep your litigation team up-to-date with **real-time alerts** and advanced team management tools built for the enterprise, all while greatly reducing PACER spend.

Our comprehensive service means we can handle Federal, State, and Administrative courts across the country.

Advanced Docket Research



With over 230 million records, Docket Alarm's cloud-native docket research platform finds what other services can't. Coverage includes Federal, State, plus PTAB, TTAB, ITC and NLRB decisions, all in one place.

Identify arguments that have been successful in the past with full text, pinpoint searching. Link to case law cited within any court document via Fastcase.

Analytics At Your Fingertips



Learn what happened the last time a particular judge, opposing counsel or company faced cases similar to yours.

Advanced out-of-the-box PTAB and TTAB analytics are always at your fingertips.

API

Docket Alarm offers a powerful API (application programming interface) to developers that want to integrate case filings into their apps.

LAW FIRMS

Build custom dashboards for your attorneys and clients with live data direct from the court.

Automate many repetitive legal tasks like conflict checks, document management, and marketing.

FINANCIAL INSTITUTIONS

Litigation and bankruptcy checks for companies and debtors.

E-DISCOVERY AND LEGAL VENDORS

Sync your system to PACER to automate legal marketing.