

AO 120 (Rev. 08/10)

TO: Mail Stop 8 Director of the U.S. Patent and Trademark Office P.O. Box 1450 Alexandria, VA 22313-1450	REPORT ON THE FILING OR DETERMINATION OF AN ACTION REGARDING A PATENT OR TRADEMARK
--	---

In Compliance with 35 U.S.C. § 290 and/or 15 U.S.C. § 1116 you are hereby advised that a court action has been filed in the U.S. District Court W.D. Washington on the following

Trademarks or Patents. (the patent action involves 35 U.S.C. § 292.):

DOCKET NO. 17-cv-932 JLR	DATE FILED 6/9/2017	U.S. DISTRICT COURT W.D. Washington
PLAINTIFF CyWee Group Ltd.		DEFENDANT HTC Corporation; and HTC America, Inc.
PATENT OR TRADEMARK NO.	DATE OF PATENT OR TRADEMARK	HOLDER OF PATENT OR TRADEMARK
1 8441438	10/8/2013	CyWee Group Ltd.
2 8552978	5/14/2013	CyWee Group Ltd.
3		
4		
5		

In the above—entitled case, the following patent(s)/ trademark(s) have been included:

DATE INCLUDED	INCLUDED BY <input type="checkbox"/> Amendment <input type="checkbox"/> Answer <input type="checkbox"/> Cross Bill <input type="checkbox"/> Other Pleading	
PATENT OR TRADEMARK NO.	DATE OF PATENT OR TRADEMARK	HOLDER OF PATENT OR TRADEMARK
1		
2		
3		
4		
5		

In the above—entitled case, the following decision has been rendered or judgement issued:

DECISION/JUDGEMENT

CLERK William M. McCool	(BY) DEPUTY CLERK Sherri Tye	DATE 6/19/2017
----------------------------	---------------------------------	-------------------

Copy 1—Upon initiation of action, mail this copy to Director Copy 3—Upon termination of action, mail this copy to Director
 Copy 2—Upon filing document adding patent(s), mail this copy to Director Copy 4—Case file copy

AO 120 (Rev. 08/10)

TO: Mail Stop 8 Director of the U.S. Patent and Trademark Office P.O. Box 1450 Alexandria, VA 22313-1450	REPORT ON THE FILING OR DETERMINATION OF AN ACTION REGARDING A PATENT OR TRADEMARK
---	---

In Compliance with 35 U.S.C. § 290 and/or 15 U.S.C. § 1116 you are hereby advised that a court action has been filed in the U.S. District Court United States District Court, District of Delaware on the following

Trademarks or Patents. (the patent action involves 35 U.S.C. § 292.):

DOCKET NO.	DATE FILED 6/16/2017	U.S. DISTRICT COURT United States District Court, District of Delaware
PLAINTIFF CYWEE GROUP LTD.		DEFENDANT MOTOROLA MOBILITY LLC
PATENT OR TRADEMARK NO.	DATE OF PATENT OR TRADEMARK	HOLDER OF PATENT OR TRADEMARK
1 8,441,438B2	5/14/2013	CYWEE GROUP LTD.
2 8,552,978B2	10/8/2013	CYWEE GROUP LTD.
3		
4		
5		

In the above—entitled case, the following patent(s)/ trademark(s) have been included:

DATE INCLUDED	INCLUDED BY <input type="checkbox"/> Amendment <input type="checkbox"/> Answer <input type="checkbox"/> Cross Bill <input type="checkbox"/> Other Pleading	
PATENT OR TRADEMARK NO.	DATE OF PATENT OR TRADEMARK	HOLDER OF PATENT OR TRADEMARK
1		
2		
3		
4		
5		

In the above—entitled case, the following decision has been rendered or judgement issued:

DECISION/JUDGEMENT

CLERK	(BY) DEPUTY CLERK	DATE
-------	-------------------	------

Copy 1—Upon initiation of action, mail this copy to Director Copy 3—Upon termination of action, mail this copy to Director
 Copy 2—Upon filing document adding patent(s), mail this copy to Director Copy 4—Case file copy

AO 120 (Rev. 08/10)

TO: Mail Stop 8 Director of the U.S. Patent and Trademark Office P.O. Box 1450 Alexandria, VA 22313-1450	REPORT ON THE FILING OR DETERMINATION OF AN ACTION REGARDING A PATENT OR TRADEMARK
---	---

In Compliance with 35 U.S.C. § 290 and/or 15 U.S.C. § 1116 you are hereby advised that a court action has been filed in the U.S. District Court Eastern District of Texas on the following

Trademarks or Patents. (the patent action involves 35 U.S.C. § 292.):

DOCKET NO.	DATE FILED 6/9/2017	U.S. DISTRICT COURT Eastern District of Texas
PLAINTIFF CYWEE GROUP LTD.		DEFENDANT HUAWEI TECHNOLOGIES CO., LTD and HUAWEI DEVICE USA, INC.
PATENT OR TRADEMARK NO.	DATE OF PATENT OR TRADEMARK	HOLDER OF PATENT OR TRADEMARK
1 8,441,438	5/14/2013	CyWee Group Limited
2 8,552,978	10/8/2013	CyWee Group Limited
3		
4		
5		

In the above—entitled case, the following patent(s)/ trademark(s) have been included:

DATE INCLUDED	INCLUDED BY <input type="checkbox"/> Amendment <input type="checkbox"/> Answer <input type="checkbox"/> Cross Bill <input type="checkbox"/> Other Pleading	
PATENT OR TRADEMARK NO.	DATE OF PATENT OR TRADEMARK	HOLDER OF PATENT OR TRADEMARK
1		
2		
3		
4		
5		

In the above—entitled case, the following decision has been rendered or judgement issued:

DECISION/JUDGEMENT

CLERK	(BY) DEPUTY CLERK	DATE
-------	-------------------	------

Copy 1—Upon initiation of action, mail this copy to Director Copy 3—Upon termination of action, mail this copy to Director
 Copy 2—Upon filing document adding patent(s), mail this copy to Director Copy 4—Case file copy

To:	Mail Stop 8 Director of the U.S. Patent and Trademark Office P.O. Box 1450 Alexandria, VA 22313-1450	REPORT ON THE FILING OR DETERMINATION OF AN ACTION REGARDING A PATENT OR TRADEMARK
-----	---	--

In Compliance with 35 U.S.C. § 290 and/or 15 U.S.C. § 1116 you are hereby advised that a court action has been filed in the U.S. District Court Southern District of California on the following: X Patents or Trademarks:

DOCKET NO.	DATE FILED	US District Court Southern District of California
3:17-cv-01102-GPC-RBB	5/31/17	San Diego, CA
PLAINTIFF		DEFENDANT
Cywee Group Ltd.		LG Electronics, Inc., et al.
PATENT OR TRADEMARK NO.	PATENT OR TRADEMARK NO.	PATENT OR TRADEMARK NO.
1. 8,441,438	6.	11.
2. 8,552,978	7.	12.
3.	8.	13.
4.	9.	14.
5.	10.	15.

In the above-entitled case, the following patents(s)/ trademark(s) have been included:

DATE INCLUDED	INCLUDED BY	
	___ Amendment ___ Answer ___ Cross Bill ___ Other Pleading	
PATENT OR TRADEMARK NO.	PATENT OR TRADEMARK NO.	PATENT OR TRADEMARK NO.
1.	6.	11.
2.	7.	12.
3.	8.	13.
4.	9.	14.
5.	10.	15.

In the above-entitled case, the following decision has been rendered or judgment issued:

DECISION/JUDGMENT

CLERK	(BY) DEPUTY CLERK	DATE
John Morrill		

To:	Mail Stop 8 Director of the U.S. Patent and Trademark Office P.O. Box 1450 Alexandria, VA 22313-1450	REPORT ON THE FILING OR DETERMINATION OF AN ACTION REGARDING A PATENT OR TRADEMARK
------------	---	--

In Compliance with 35 U.S.C. § 290 and/or 15 U.S.C. § 1116 you are hereby advised that a court action has been filed in the U.S. District Court Southern District of California on the following: X Patents or Trademarks:

DOCKET NO.	DATE FILED	US District Court Southern District of California
3:17-cv-01102-GPC-RBB	5/31/17	San Diego, CA
PLAINTIFF		DEFENDANT
Cywee Group Ltd.		LG Electronics, Inc., et al.
PATENT OR TRADEMARK NO.	PATENT OR TRADEMARK NO.	PATENT OR TRADEMARK NO.
1. 8,441,438	6.	11.
2. 8,552,978	7.	12.
3.	8.	13.
4.	9.	14.
5.	10.	15.

In the above-entitled case, the following patents(s)/ trademark(s) have been included:

DATE INCLUDED	INCLUDED BY	
	Amendment <u> </u> Answer <u> </u> Cross Bill <u> </u> Other Pleading <u> </u>	
PATENT OR TRADEMARK NO.	PATENT OR TRADEMARK NO.	PATENT OR TRADEMARK NO.
1.	6.	11.
2.	7.	12.
3.	8.	13.
4.	9.	14.
5.	10.	15.

In the above-entitled case, the following decision has been rendered or judgment issued:

DECISION/JUDGMENT

CLERK John Morrill	(BY) DEPUTY CLERK	DATE
------------------------------	--------------------------	-------------

TO: Mail Stop 8 Director of the U.S. Patent & Trademark Office P.O. Box 1450 Alexandria, VA 22313-1450	REPORT ON THE FILING OR DETERMINATION OF AN ACTION REGARDING A PATENT OR TRADEMARK
---	---

In Compliance with 35 § 290 and/or 15 U.S.C. § 1116 you are hereby advised that a court action has been
 filed in the U.S. District Court Northern District of California on the following Patents or Trademarks:

DOCKET NO. CV 14-01853 JSC	DATE FILED 4/22/14	U.S. DISTRICT COURT 450 Golden Gate Avenue, P.O. Box 36060, San Francisco, CA 94102
PLAINTIFF CYWEE GROUP LTD		DEFENDANT APPLE INC
PATENT OR TRADEMARK NO.	DATE OF PATENT OR TRADEMARK	HOLDER OF PATENT OR TRADEMARK
1 see Complaint		
2 8,552,978		
3 8,441,438		
4		
5		

In the above—entitled case, the following patent(s) have been included:

DATE INCLUDED	INCLUDED BY <input type="checkbox"/> Amendment <input type="checkbox"/> Answer <input type="checkbox"/> Cross Bill <input type="checkbox"/> Other Pleading		
PATENT OR TRADEMARK NO.	DATE OF PATENT OR TRADEMARK	HOLDER OF PATENT OR TRADEMARK	
1			
2			
3			
4			
5			

In the above—entitled case, the following decision has been rendered or judgement issued:

DECISION/JUDGEMENT

CLERK Richard W. Wicking	(BY) DEPUTY CLERK Sheila Rash	DATE April 23, 2014
-----------------------------	----------------------------------	------------------------

Copy 1—Upon initiation of action, mail this copy to Commissioner
 Copy 2—Upon filing document adding patent(s), mail this copy to Commissioner
 Copy 3—Upon termination of action, mail this copy to Commissioner
 Copy 4—Case file copy

TO: Mail Stop 8 Director of the U.S. Patent & Trademark Office P.O. Box 1450 Alexandria, VA 22313-1450	REPORT ON THE FILING OR DETERMINATION OF AN ACTION REGARDING A PATENT OR TRADEMARK
---	---

In Compliance with 35 § 290 and/or 15 U.S.C. § 1116 you are hereby advised that a court action has been filed in the U.S. District Court Northern District of California on the following Patents or Trademarks:

DOCKET NO. CV 14-01853 JSC	DATE FILED 4/22/14	U.S. DISTRICT COURT 450 Golden Gate Avenue, P.O. Box 36060, San Francisco, CA 94102
PLAINTIFF CYWEE GROUP LTD		DEFENDANT APPLE INC
PATENT OR TRADEMARK NO.	DATE OF PATENT OR TRADEMARK	HOLDER OF PATENT OR TRADEMARK
1 see Complaint		
2 8,552,978		
3 8,441,438		
4		
5		

In the above—entitled case, the following patent(s) have been included:

DATE INCLUDED	INCLUDED BY	
	<input checked="" type="checkbox"/> Amendment <input type="checkbox"/> Answer <input type="checkbox"/> Cross Bill <input type="checkbox"/> Other Pleading	
PATENT OR TRADEMARK NO.	DATE OF PATENT OR TRADEMARK	HOLDER OF PATENT OR TRADEMARK
1 See Amended Complaint		
2		
3		
4		
5		

In the above—entitled case, the following decision has been rendered or judgement issued:

DECISION/JUDGEMENT

CLERK Richard W. Wicking	(BY) DEPUTY CLERK Sheila Rash	DATE April 23, 2014
-----------------------------	----------------------------------	------------------------

Copy 1—Upon initiation of action, mail this copy to Commissioner Copy 3—Upon termination of action, mail this copy to Commissioner
 Copy 2—Upon filing document adding patent(s), mail this copy to Commissioner Copy 4—Case file copy

1 Jill F. Kopeikin (State Bar No. 160792)
2 Valerie M. Wagner (State Bar No. 173146)
3 GCA LAW PARTNERS LLP
4 2570 W. El Camino Real, Suite 510
5 Mountain View, CA 94040
6 Telephone: (650) 428-3900
7 Fax: (650) 428-3901
8 jkopeikin@gcalaw.com
9 vwagner@gcalaw.com

10 Attorneys for Plaintiff
11 CYWEE GROUP LTD.

12 **IN THE UNITED STATES DISTRICT COURT**
13 **FOR THE NORTHERN DISTRICT OF CALIFORNIA**

14 CYWEE GROUP LTD.,
15 *Plaintiff,*

16 APPLE INC.,
17 *Defendant.*

CASE NO. 3:14-CV-01853 JSC

CYWEE'S FIRST AMENDED
COMPLAINT FOR PATENT
INFRINGEMENT

DEMAND FOR JURY TRIAL

18
19 Plaintiff CyWee Group Ltd. ("Plaintiff" or "CyWee") by and through its
20 undersigned counsel, files this First Amended Complaint against Defendant Apple,
21 Inc. ("Defendant" or "Apple) as follows:

22 **THE PARTIES**

23 1. CyWee Group Ltd. is a corporation existing under the laws of the
24 British Virgin Islands with a principal place of business at 3F, No.28, Lane 128, Jing
25 Ye 1st Road, Taipei, Taiwan 10462.

26 2. CyWee is a world leading technology company that focuses on building
27 products and services for consumers and businesses. CyWee is widely known as
28 having one of the most significant patent portfolios in the industry, and is considered

FIRST AMENDED COMPLAINT FOR PATENT INFRINGEMENT
CASE NO. 3:14-CV-01853 JSC

1 a market leader in its core development areas of motion processing, wireless high
2 definition video delivery, and facial tracking technology.

3 3. Upon information and belief, Defendant Apple Inc. is a corporation
4 organized under the laws of California, and its principal place of business is 1
5 Infinite Loop, Cupertino, California 95014. Apple's registered agent for service of
6 process is CT Corporation System, 818 West Seventh St., 2nd Floor, Los Angeles,
7 California 90017.

8 **JURISDICTION AND VENUE**

9 4. This action arises under the patent laws of the United States, 35 U.S.C.
10 § 1 *et seq.*, including 35 U.S.C. § 271, 281, 283, 284, and 285. This Court has
11 subject matter jurisdiction pursuant to 28 U.S.C. §§ 1331 and 1338(a).

12 5. This Court has personal jurisdiction over Defendant because Defendant
13 resides and has its primary place of business in Cupertino, California, within this
14 District. This Court also has personal jurisdiction over Defendant because Defendant
15 has purposefully and voluntarily availed itself of the privilege of doing business in
16 the United States, the State of California, and the Northern District of California by
17 continuously and systematically placing goods into the stream of commerce with the
18 expectation that they will be purchased by consumers in the Northern District of
19 California. Upon information and belief, Defendant has committed acts of patent
20 infringement within the State of California and, more particularly, within the
21 Northern District of California.

22 6. Venue is proper in the Northern District of California pursuant to 28
23 U.S.C. §§ 1391(b) and 1400(b), in that, Defendant resides in this District, has a
24 regular and established place of business in this District, and has committed acts of
25 infringement in this District.

1
2
3
4
5
6
7
8
9
10
11
12
13
14
15
16
17
18
19
20
21
22
23
24
25
26
27
28

INTRADISTRICT ASSIGNMENT

7. This action is an intellectual property action subject to district-wide assignment.

PATENT INFRINGEMENT OF U.S. PATENT NO. 8,552,978

8. Plaintiff repeats and re-alleges each and every allegation of paragraphs 1-7 as though fully set forth herein.

9. U.S. Patent No. 8,552,978 (the '978 Patent"), titled "3D Pointing Device and Method for Compensating Rotations of the 3D Pointing Device Thereof," was duly and legally issued by the United States Patent and Trademark Office on October 8, 2013 to Cywee Group Limited, as assignee of named inventors Zhou Ye, Chin-Lung Li, Shun-Nan Liou. A true and correct copy of the '978 Patent is attached hereto as Exhibit A.

10. CyWee is the owner of all right, title, and interest in and to the '978 Patent with full right to bring suit to enforce the patent, including the right to recover for past infringement damages.

11. Each and every claim of the '978 Patent is valid and enforceable and each enjoys a statutory presumption of validity separate, apart, and in addition to the statutory presumption of validity enjoyed by every other of its claims. 35 U.S.C. § 282.

12. Apple has at no time, either expressly or impliedly, been licensed under the '978 Patent.

13. The '978 Patent describes and claims, *inter alia*, 3D pointing devices and methods for compensating rotations of the 3D pointing device.

14. CyWee is informed and believes, and thereupon alleges, that Apple, without authorization or license, has been, and is currently directly or indirectly infringing one or more claims of the '978 Patent in violation of 35 U.S.C. § 271, including as stated below.

1 15. CyWee is informed and believes, and thereupon alleges, that Apple has
2 directly infringed, literally and/or under the doctrine of equivalents, and will
3 continue to directly infringe each patent claim of the '978 Patent by making, using,
4 selling, offering to sell, and/or importing into the United States products that
5 embody or practice the apparatus and/or method covered by one or more claims of
6 the '978 Patent, including but not limited to the Defendant's iPhone 5s, iPad Air,
7 and iPad mini (2nd generation) (collectively referred to as "Accused Products").

8 16. Apple has had knowledge of and notice of the '978 Patent and Apple's
9 infringement of the '978 Patent since at least March 31, 2014, and through, the filing
10 and service of this Complaint and despite this knowledge continues to infringe. On
11 March 31, 2014, CyWee disclosed several patents, including the '978 Patent, in pre-
12 suit licensing discussions with Apple. Apple's infringement of the '978 patent has
13 been and continues to be willful and deliberate.

14 17. CyWee is informed and believes, and thereupon alleges, that Apple
15 actively induces customers to infringe the '978 Patent in violation of 35 U.S.C. §
16 271(b) by instructing and otherwise encouraging infringement and by providing
17 infringing mobile devices and 3D pointing technologies preinstalled in the Accused
18 Products. For example, Apple provides application developers a Core Motion
19 Framework Reference for Apple's iOS platform to enable end users to enable the
20 Accused Products' hardware to determine current position or motion associated with
21 the device. Consumers of the Accused Products then directly or jointly infringe the
22 '978 Patent.

23 18. CyWee is informed and believes, and thereupon alleges, that Apple
24 knowingly offers to sell or sells within the United States or imports into the United
25 States the Accused Products that contain infringing 3D pointing technologies
26 preinstalled. The 3D pointing technologies are especially made or especially adapted
27 for use in infringement of the '978 Patent. The Accused Products are not staple
28

1 articles or commodities of commerce suitable for substantial non-infringing use and
2 constitute a material part of the invention claimed by the '978 Patent at least because
3 Apple's 3D pointing technologies in the Accused Products work in conjunction with
4 mobile applications in a manner that infringes the '978 Patent. Therefore, Apple is
5 also contributing to the direct infringement of the '978 Patent by the users of these
6 products.

7 19. Defendant's acts of infringement have caused and will continue to
8 cause substantial and irreparable damage to CyWee.

9 20. As a result of the infringement of the '978 Patent by Defendant, CyWee
10 has been damaged. CyWee is, therefore, entitled to such damages pursuant to 35
11 U.S.C. § 284 in an amount that presently cannot be pled but that will be determined
12 at trial.

13 **PATENT INFRINGEMENT OF U.S. PATENT NO. 8,441,438**

14 21. Plaintiff repeats and re-alleges each and every allegation of paragraphs
15 1-7 as though fully set forth herein.

16 22. U.S. Patent No. 8,441,438 (the '438 Patent"), titled "3D Pointing
17 Device and Method for Compensating Movement Thereof," was duly and legally
18 issued by the United States Patent and Trademark Office on May 14, 2013 to Cywee
19 Group Limited, as assignee of named inventors Zhou Ye, Chin-Lung Li, Shun-Nan
20 Liou. A true and correct copy of the '438 Patent is attached hereto as Exhibit B.

21 23. CyWee is the owner of all right, title, and interest in and to the '438
22 Patent with full right to bring suit to enforce the patent, including the right to recover
23 for past infringement damages.

24 24. Each and every claim of the '438 Patent is valid and enforceable and
25 each enjoys a statutory presumption of validity separate, apart, and in addition to the
26 statutory presumption of validity enjoyed by every other of its claims. 35 U.S.C. §
27 282.

1 25. Apple has at no time, either expressly or impliedly, been licensed under
2 the '438 Patent.

3 26. The '438 Patent describes and claims, *inter alia*, 3D pointing devices
4 and methods for compensating movement.

5 27. CyWee is informed and believes, and thereupon alleges, that Apple,
6 without authorization or license, has been, and is currently directly or indirectly
7 infringing one or more claims of the '438 Patent in violation of 35 U.S.C. § 271,
8 including as stated below.

9 28. CyWee is informed and believes, and thereupon alleges, that Apple has
10 directly infringed, literally and/or under the doctrine of equivalents, and will
11 continue to directly infringe each patent claim of the '438 Patent by making, using,
12 selling, offering to sell, and/or importing into the United States the Accused
13 Products that embody or practice the apparatus and/or method covered by one or
14 more claims of the '438 Patent, including but not limited to the Accused Products.

15 29. Apple has had knowledge of and notice of the '438 Patent and Apple's
16 infringement of the '438 Patent since at least March 31, 2014, and through, the filing
17 and service of this Complaint and despite this knowledge continues to infringe. On
18 March 31, 2014, CyWee disclosed several patents, including the '438 Patent, in pre-
19 suit licensing discussions with Apple. Apple's infringement of the '438 patent has
20 been and continues to be willful and deliberate.

21 30. CyWee is informed and believes, and thereupon alleges, that Apple
22 actively induces customers to infringe the '438 Patent in violation of 35 U.S.C. §
23 271(b) by instructing and otherwise encouraging infringement and by providing
24 infringing mobile devices and 3D pointing technologies preinstalled in the Accused
25 Products. For example, Apple provides application developers a Core Motion
26 Framework Reference for Apple's iOS platform to enable end users to enable the
27 Accused Products' hardware to determine current position or motion associated with
28

1 the device. Consumers of the Accused Products then directly or jointly infringe the
2 '438 Patent.

3 31. CyWee is informed and believes, and thereupon alleges, that Apple
4 knowingly offers to sell or sells within the United States or imports into the United
5 States the Accused Products that contain infringing 3D pointing technologies
6 preinstalled. The 3D pointing technologies are especially made or especially adapted
7 for use in infringement of the '438 Patent. The Accused Products are not staple
8 articles or commodities of commerce suitable for substantial non-infringing use and
9 constitute a material part of the invention claimed by the '438 Patent at least because
10 Apple's 3D pointing technologies in the Accused Products work in conjunction with
11 mobile applications in a manner that infringes the '438 Patent. Therefore, Apple is
12 also contributing to the direct infringement of the '438 Patent by the users of these
13 products.

14 32. Defendant's acts of infringement have caused and will continue to
15 cause substantial and irreparable damage to CyWee.

16 33. As a result of the infringement of the '438 Patent by Defendant, CyWee
17 has been damaged. CyWee is, therefore, entitled to such damages pursuant to 35
18 U.S.C. § 284 in an amount that presently cannot be pled but that will be determined
19 at trial.

20 **PRAYER FOR RELIEF**

21 WHEREFORE, Plaintiff prays for entry of judgment against Defendant as
22 follows:

- 23 A. A judgment that Defendant has infringed and continues to infringe the
24 '978 Patent and '438 Patent, directly and/or indirectly by way of
25 inducing or contributing to infringement of such patents as alleged
26 herein;

1
2
3
4
5
6
7
8
9
10
11
12
13
14
15
16
17
18
19
20
21
22
23
24
25
26
27
28

- B. That Defendant provide to CyWee an accounting of all gains, profits and advantages derived by Defendant's infringement of the '978 Patent and '438 Patent, and that CyWee be awarded damages adequate to compensate them for the wrongful infringement by Defendant, including treble damages for willful infringement, in accordance with 35 U.S.C. § 284;
- C. That CyWee be awarded any other supplemental damages and interest on all damages, including, but not limited to attorney fees available under 35 U.S.C. § 285;
- D. That the Court permanently enjoin Defendant and all those in privity with Defendant from making, having made, selling, offering for sale, distributing and/or using products that infringe the '978 Patent and '438, including the Accused Products, in the United States; and
- E. That CyWee be awarded such other and further relief and all remedies available at law.

DEMAND FOR JURY TRIAL

Pursuant to Federal Rule of Civil Procedure 38(b), CyWee hereby demands a trial by jury on all issues triable to a jury.

Dated: May 9, 2014

Respectfully submitted,

/s/ Jill F. Kopeikin

Jill F. Kopeikin (State Bar No. 160792)
jkopeikin@gcalaw.com
GCA LAW PARTNERS LLP
2570 W. El Camino Real, Suite 510
Mountain View, CA 94040
Telephone: (650) 428-3900
Fax: (650) 428-3901

AO 120 (Rev. 2/99)

TO: Mail Stop 8 Director of the U.S. Patent & Trademark Office P.O. Box 1450 Alexandria, VA 22313-1450	REPORT ON THE FILING OR DETERMINATION OF AN ACTION REGARDING A PATENT OR TRADEMARK
---	--

In Compliance with 35 § 290 and/or 15 U.S.C. § 1116 you are hereby advised that a court action has been filed in the U.S. District Court Northern District of California on the following Patents or Trademarks:

DOCKET NO. CV 14-01853 JSC	DATE FILED 4/22/14	U.S. DISTRICT COURT 450 Golden Gate Avenue, P.O. Box 36060, San Francisco, CA 94102
PLAINTIFF CYWEE GROUP LTD		DEFENDANT APPLE INC
PATENT OR TRADEMARK NO.	DATE OF PATENT OR TRADEMARK	HOLDER OF PATENT OR TRADEMARK
1 see Complaint		
28,552,978		
38,441,438		
4		
5		

In the above—entitled case, the following patent(s) have been included:

DATE INCLUDED	INCLUDED BY <input checked="" type="checkbox"/> Amendment <input type="checkbox"/> Answer <input type="checkbox"/> Cross Bill <input type="checkbox"/> Other Pleading		
PATENT OR TRADEMARK NO.	DATE OF PATENT OR TRADEMARK	HOLDER OF PATENT OR TRADEMARK	
1 See Amended Complaint			
2			
3			
4			
5			

In the above—entitled case, the following decision has been rendered or judgement issued:

DECISION/JUDGEMENT

CLERK Richard W. Wicking	(BY) DEPUTY CLERK Sheila Rash	DATE April 23, 2014
-----------------------------	----------------------------------	------------------------

Copy 1—Upon initiation of action, mail this copy to Commissioner Copy 3—Upon termination of action, mail this copy to Commissioner
 Copy 2—Upon filing document adding patent(s), mail this copy to Commissioner Copy 4—Case file copy



APPLICATION NO.	ISSUE DATE	PATENT NO.	ATTORNEY DOCKET NO.	CONFIRMATION NO.
13/176,771	10/08/2013	8552978	040-13-0052.IUS	5154

66749 7590 09/18/2013
DING YU TAN
22114 LEGENDRE RD
RICHMOND, TX 77407

ISSUE NOTIFICATION

The projected patent number and issue date are specified above.

Determination of Patent Term Adjustment under 35 U.S.C. 154 (b) (application filed on or after May 29, 2000)

The Patent Term Adjustment is 144 day(s). Any patent to issue from the above-identified application will include an indication of the adjustment on the front page.

If a Continued Prosecution Application (CPA) was filed in the above-identified application, the filing date that determines Patent Term Adjustment is the filing date of the most recent CPA.

Applicant will be able to obtain more detailed information by accessing the Patent Application Information Retrieval (PAIR) WEB site (<http://pair.uspto.gov>).

Any questions regarding the Patent Term Extension or Adjustment determination should be directed to the Office of Patent Legal Administration at (571)-272-7702. Questions relating to issue and publication fee payments should be directed to the Application Assistance Unit (AAU) of the Office of Data Management (ODM) at (571)-272-4200.

APPLICANT(s) (Please see PAIR WEB site <http://pair.uspto.gov> for additional applicants):

Zhou Ye, Foster City, CA;
Chin-Lung Li, Taoyuan County, TAIWAN;
Shun-Nan Liou, Kaohsiung City, TAIWAN;

The United States represents the largest, most dynamic marketplace in the world and is an unparalleled location for business investment, innovation, and commercialization of new technologies. The USA offers tremendous resources and advantages for those who invest and manufacture goods here. Through SelectUSA, our nation works to encourage and facilitate business investment. To learn more about why the USA is the best country in the world to develop technology, manufacture products, and grow your business, visit SelectUSA.gov.

PART B - FEE(S) TRANSMITTAL

Complete and send this form, together with applicable fee(s), to: **Mail** **Mail Stop ISSUE FEE**
Commissioner for Patents
P.O. Box 1450
Alexandria, Virginia 22313-1450
 or **Fax** **(571)-273-2885**

INSTRUCTIONS: This form should be used for transmitting the ISSUE FEE and PUBLICATION FEE (if required). Blocks 1 through 5 should be completed where appropriate. All further correspondence including the Patent, advance orders and notification of maintenance fees will be mailed to the current correspondence address as indicated unless corrected below or directed otherwise in Block 1, by (a) specifying a new correspondence address; and/or (b) indicating a separate "FEE ADDRESS" for maintenance fee notifications.

CURRENT CORRESPONDENCE ADDRESS (Note: Use Block 1 for any change of address)

66749 7590 06/25/2013
DING YU TAN
 22114 LEGENDRE RD
 RICHMOND, TX 77407

Note: A certificate of mailing can only be used for domestic mailings of the Fee(s) Transmittal. This certificate cannot be used for any other accompanying papers. Each additional paper, such as an assignment or formal drawing, must have its own certificate of mailing or transmission.

Certificate of Mailing or Transmission

I hereby certify that this Fee(s) Transmittal is being deposited with the United States Postal Service with sufficient postage for first class mail in an envelope addressed to the Mail Stop ISSUE FEE address above, or being facsimile transmitted to the USPTO (571) 273-2885, on the date indicated below.

(Depositor's name)
(Signature)
(Date)

APPLICATION NO.	FILING DATE	FIRST NAMED INVENTOR	ATTORNEY DOCKET NO.	CONFIRMATION NO.
13/176,771	07/06/2011	Zhou Ye	040-13-0052.IUS	5154

TITLE OF INVENTION: 3D POINTING DEVICE AND METHOD FOR COMPENSATING ROTATIONS OF THE 3D POINTING DEVICE THEREOF

APPLN. TYPE	ENTITY STATUS	ISSUE FEE DUE	PUBLICATION FEE DUE	PREV. PAID ISSUE FEE	TOTAL FEE(S) DUE	DATE DUE
nonprovisional	SMALL	\$890	\$300	\$0	\$1190	09/25/2013

EXAMINER	ART UNIT	CLASS-SUBCLASS
SADIO, INSA	2692	345-157000

1. Change of correspondence address or indication of "Fee Address" (37 CFR 1.363).

Change of correspondence address (or Change of Correspondence Address form PTO/SB/122) attached.

"Fee Address" indication (or "Fee Address" Indication form PTO/SB/47; Rev 03-02 or more recent) attached. Use of a Customer Number is required.

2. For printing on the patent front page, list

(1) the names of up to 3 registered patent attorneys or agents OR, alternatively,

(2) the name of a single firm (having as a member a registered attorney or agent) and the names of up to 2 registered patent attorneys or agents. If no name is listed, no name will be printed.

1. Ding Yu Tan

2. _____

3. _____

3. ASSIGNEE NAME AND RESIDENCE DATA TO BE PRINTED ON THE PATENT (print or type)

PLEASE NOTE: Unless an assignee is identified below, no assignee data will appear on the patent. If an assignee is identified below, the document has been filed for recordation as set forth in 37 CFR 3.11. Completion of this form is NOT a substitute for filing an assignment.

(A) NAME OF ASSIGNEE: **CYWEE GROUP LIMITED**

(B) RESIDENCE: (CITY and STATE OR COUNTRY) **TORTOLA, VG**

Please check the appropriate assignee category or categories (will not be printed on the patent): Individual Corporation or other private group entity Government

4a. The following fee(s) are submitted:

Issue Fee

Publication Fee (No small entity discount permitted)

Advance Order - # of Copies _____

4b. Payment of Fee(s): (Please first reapply any previously paid issue fee shown above)

A check is enclosed.

Payment by credit card. Form PTO-2038 is attached.

The Director is hereby authorized to charge the required fee(s), any deficiency, or credit any overpayment, to Deposit Account Number _____ (enclose an extra copy of this form).

5. **Change in Entity Status** (from status indicated above)

- Applicant certifying micro entity status. See 37 CFR 1.29
- Applicant asserting small entity status. See 37 CFR 1.27
- Applicant changing to regular undiscounted fee status.

NOTE: Absent a valid certification of Micro Entity Status (see form PTO/SB/15A and 15B), issue fee payment in the micro entity amount will not be accepted at the risk of application abandonment.

NOTE: If the application was previously under micro entity status, checking this box will be taken to be a notification of loss of entitlement to micro entity status.

NOTE: Checking this box will be taken to be a notification of loss of entitlement to small or micro entity status, as applicable.

NOTE: The Issue Fee and Publication Fee (if required) will not be accepted from anyone other than the applicant; a registered attorney or agent; or the assignee or other party in interest as shown by the records of the United States Patent and Trademark Office.

Authorized Signature 
 Typed or printed name Ding Yu Tan

Date 09/04/2013
 Registration No. 58812

This collection of information is required by 37 CFR 1.311. The information is required to obtain or retain a benefit by the public which is to file (and by the USPTO to process) in application. Confidentiality is governed by 35 U.S.C. 122 and 37 CFR 1.14. This collection is estimated to take 12 minutes to complete, including gathering, preparing, and submitting the completed application form to the USPTO. Time will vary depending upon the individual case. Any comments on the amount of time you require to complete this form and/or suggestions for reducing this burden, should be sent to the Chief Information Officer, U.S. Patent and Trademark Office, U.S. Department of Commerce, P.O. Box 1450, Alexandria, Virginia 22313-1450. DO NOT SEND FEES OR COMPLETED FORMS TO THIS ADDRESS. SEND TO: Commissioner for Patents, P.O. Box 1450, Alexandria, Virginia 22313-1450.

Under the Paperwork Reduction Act of 1995, no persons are required to respond to a collection of information unless it displays a valid OMB control number.

Electronic Patent Application Fee Transmittal

Application Number:	13176771
Filing Date:	06-Jul-2011
Title of Invention:	3D POINTING DEVICE AND METHOD FOR COMPENSATING ROTATIONS OF THE 3D POINTING DEVICE THEREOF
First Named Inventor/Applicant Name:	Zhou Ye
Filer:	Ding Yu Tan
Attorney Docket Number:	040-13-0052.IUS

Filed as Small Entity

Utility under 35 USC 111(a) Filing Fees

Description	Fee Code	Quantity	Amount	Sub-Total in USD(\$)
Basic Filing:				
Pages:				
Claims:				
Miscellaneous-Filing:				
Petition:				
Patent-Appeals-and-Interference:				
Post-Allowance-and-Post-Issuance:				
Utility Appl Issue Fee	2501	1	890	890
Publ. Fee- Early, Voluntary, or Normal	1504	1	300	300
020				

Description	Fee Code	Quantity	Amount	Sub-Total in USD(\$)
Extension-of-Time:				
Miscellaneous:				
Total in USD (\$)				1190

Electronic Acknowledgement Receipt

EFS ID:	16766359
Application Number:	13176771
International Application Number:	
Confirmation Number:	5154
Title of Invention:	3D POINTING DEVICE AND METHOD FOR COMPENSATING ROTATIONS OF THE 3D POINTING DEVICE THEREOF
First Named Inventor/Applicant Name:	Zhou Ye
Customer Number:	66749
Filer:	Ding Yu Tan
Filer Authorized By:	
Attorney Docket Number:	040-13-0052.IUS
Receipt Date:	04-SEP-2013
Filing Date:	06-JUL-2011
Time Stamp:	22:27:52
Application Type:	Utility under 35 USC 111(a)

Payment information:

Submitted with Payment	yes
Payment Type	Credit Card
Payment was successfully received in RAM	\$1190
RAM confirmation Number	11075
Deposit Account	
Authorized User	

File Listing:

Document Number	Document Description	File Name	File Size(Bytes)/ Message Digest	Multi Part /.zip	Pages (if appl.)
		022			

1	Issue Fee Payment (PTO-85B)	201011_D_US_Issue_fee_paym ent.pdf	71803 41b713e518c5e55450d10464aa51c4d54da 727b1	no	2
Warnings:					
Information:					
2	Fee Worksheet (SB06)	fee-info.pdf	31874 4e798813f4ede0ad27ec0814e9307e47dc5 057e6	no	2
Warnings:					
Information:					
Total Files Size (in bytes):			103677		

This Acknowledgement Receipt evidences receipt on the noted date by the USPTO of the indicated documents, characterized by the applicant, and including page counts, where applicable. It serves as evidence of receipt similar to a Post Card, as described in MPEP 503.

New Applications Under 35 U.S.C. 111

If a new application is being filed and the application includes the necessary components for a filing date (see 37 CFR 1.53(b)-(d) and MPEP 506), a Filing Receipt (37 CFR 1.54) will be issued in due course and the date shown on this Acknowledgement Receipt will establish the filing date of the application.

National Stage of an International Application under 35 U.S.C. 371

If a timely submission to enter the national stage of an international application is compliant with the conditions of 35 U.S.C. 371 and other applicable requirements a Form PCT/DO/EO/903 indicating acceptance of the application as a national stage submission under 35 U.S.C. 371 will be issued in addition to the Filing Receipt, in due course.

New International Application Filed with the USPTO as a Receiving Office

If a new international application is being filed and the international application includes the necessary components for an international filing date (see PCT Article 11 and MPEP 1810), a Notification of the International Application Number and of the International Filing Date (Form PCT/RO/105) will be issued in due course, subject to prescriptions concerning national security, and the date shown on this Acknowledgement Receipt will establish the international filing date of the application.



NOTICE OF ALLOWANCE AND FEE(S) DUE

66749 7590 06/25/2013
DING YU TAN
22114 LEGENDRE RD
RICHMOND, TX 77407

EXAMINER
SADIO, INSA
ART UNIT PAPER NUMBER

2692
DATE MAILED: 06/25/2013

Table with 5 columns: APPLICATION NO., FILING DATE, FIRST NAMED INVENTOR, ATTORNEY DOCKET NO., CONFIRMATION NO.

13/176,771 07/06/2011 Zhou Ye 040-13-0052.IUS 5154
TITLE OF INVENTION: 3D POINTING DEVICE AND METHOD FOR COMPENSATING ROTATIONS OF THE 3D POINTING DEVICE THEREOF

Table with 7 columns: APPLN. TYPE, ENTITY STATUS, ISSUE FEE DUE, PUBLICATION FEE DUE, PREV. PAID ISSUE FEE, TOTAL FEE(S) DUE, DATE DUE

THE APPLICATION IDENTIFIED ABOVE HAS BEEN EXAMINED AND IS ALLOWED FOR ISSUANCE AS A PATENT. PROSECUTION ON THE MERITS IS CLOSED. THIS NOTICE OF ALLOWANCE IS NOT A GRANT OF PATENT RIGHTS. THIS APPLICATION IS SUBJECT TO WITHDRAWAL FROM ISSUE AT THE INITIATIVE OF THE OFFICE OR UPON PETITION BY THE APPLICANT. SEE 37 CFR 1.313 AND MPEP 1308.

THE ISSUE FEE AND PUBLICATION FEE (IF REQUIRED) MUST BE PAID WITHIN THREE MONTHS FROM THE MAILING DATE OF THIS NOTICE OR THIS APPLICATION SHALL BE REGARDED AS ABANDONED. THIS STATUTORY PERIOD CANNOT BE EXTENDED. SEE 35 U.S.C. 151. THE ISSUE FEE DUE INDICATED ABOVE DOES NOT REFLECT A CREDIT FOR ANY PREVIOUSLY PAID ISSUE FEE IN THIS APPLICATION. IF AN ISSUE FEE HAS PREVIOUSLY BEEN PAID IN THIS APPLICATION (AS SHOWN ABOVE), THE RETURN OF PART B OF THIS FORM WILL BE CONSIDERED A REQUEST TO REAPPLY THE PREVIOUSLY PAID ISSUE FEE TOWARD THE ISSUE FEE NOW DUE.

HOW TO REPLY TO THIS NOTICE:

I. Review the ENTITY STATUS shown above. If the ENTITY STATUS is shown as SMALL or MICRO, verify whether entitlement to that entity status still applies.
If the ENTITY STATUS is the same as shown above, pay the TOTAL FEE(S) DUE shown above.
If the ENTITY STATUS is changed from that shown above, on PART B - FEE(S) TRANSMITTAL, complete section number 5 titled "Change in Entity Status (from status indicated above)".
For purposes of this notice, small entity fees are 1/2 the amount of undiscounted fees, and micro entity fees are 1/2 the amount of small entity fees.

II. PART B - FEE(S) TRANSMITTAL, or its equivalent, must be completed and returned to the United States Patent and Trademark Office (USPTO) with your ISSUE FEE and PUBLICATION FEE (if required). If you are charging the fee(s) to your deposit account, section "4b" of Part B - Fee(s) Transmittal should be completed and an extra copy of the form should be submitted. If an equivalent of Part B is filed, a request to reapply a previously paid issue fee must be clearly made, and delays in processing may occur due to the difficulty in recognizing the paper as an equivalent of Part B.

III. All communications regarding this application must give the application number. Please direct all communications prior to issuance to Mail Stop ISSUE FEE unless advised to the contrary.

IMPORTANT REMINDER: Utility patents issuing on applications filed on or after Dec. 12, 1980 may require payment of maintenance fees. It is patentee's responsibility to ensure timely payment of maintenance fees when due.

PART B - FEE(S) TRANSMITTAL

**Complete and send this form, together with applicable fee(s), to: Mail Mail Stop ISSUE FEE
 Commissioner for Patents
 P.O. Box 1450
 Alexandria, Virginia 22313-1450
 or Fax (571)-273-2885**

INSTRUCTIONS: This form should be used for transmitting the ISSUE FEE and PUBLICATION FEE (if required). Blocks 1 through 5 should be completed where appropriate. All further correspondence including the Patent, advance orders and notification of maintenance fees will be mailed to the current correspondence address as indicated unless corrected below or directed otherwise in Block 1, by (a) specifying a new correspondence address; and/or (b) indicating a separate "FEE ADDRESS" for maintenance fee notifications.

CURRENT CORRESPONDENCE ADDRESS (Note: Use Block 1 for any change of address)

Note: A certificate of mailing can only be used for domestic mailings of the Fee(s) Transmittal. This certificate cannot be used for any other accompanying papers. Each additional paper, such as an assignment or formal drawing, must have its own certificate of mailing or transmission.

66749 7590 06/25/2013
DING YU TAN
 22114 LEGENDRE RD
 RICHMOND, TX 77407

Certificate of Mailing or Transmission

I hereby certify that this Fee(s) Transmittal is being deposited with the United States Postal Service with sufficient postage for first class mail in an envelope addressed to the Mail Stop ISSUE FEE address above, or being facsimile transmitted to the USPTO (571) 273-2885, on the date indicated below.

(Depositor's name)
(Signature)
(Date)

APPLICATION NO.	FILING DATE	FIRST NAMED INVENTOR	ATTORNEY DOCKET NO.	CONFIRMATION NO.
13/176,771	07/06/2011	Zhou Ye	040-13-0052.IUS	5154

TITLE OF INVENTION: 3D POINTING DEVICE AND METHOD FOR COMPENSATING ROTATIONS OF THE 3D POINTING DEVICE THEREOF

APPLN. TYPE	ENTITY STATUS	ISSUE FEE DUE	PUBLICATION FEE DUE	PREV. PAID ISSUE FEE	TOTAL FEE(S) DUE	DATE DUE
nonprovisional	SMALL	\$890	\$300	\$0	\$1190	09/25/2013

EXAMINER	ART UNIT	CLASS-SUBCLASS
SADIO, INSA	2692	345-157000

<p>1. Change of correspondence address or indication of "Fee Address" (37 CFR 1.363).</p> <p><input type="checkbox"/> Change of correspondence address (or Change of Correspondence Address form PTO/SB/122) attached.</p> <p><input type="checkbox"/> "Fee Address" indication (or "Fee Address" Indication form PTO/SB/47; Rev 03-02 or more recent) attached. Use of a Customer Number is required.</p>	<p>2. For printing on the patent front page, list</p> <p>(1) the names of up to 3 registered patent attorneys or agents OR, alternatively, 1 _____</p> <p>(2) the name of a single firm (having as a member a registered attorney or agent) and the names of up to 2 registered patent attorneys or agents. If no name is listed, no name will be printed. 2 _____</p> <p>3 _____</p>
---	---

3. ASSIGNEE NAME AND RESIDENCE DATA TO BE PRINTED ON THE PATENT (print or type)

PLEASE NOTE: Unless an assignee is identified below, no assignee data will appear on the patent. If an assignee is identified below, the document has been filed for recordation as set forth in 37 CFR 3.11. Completion of this form is NOT a substitute for filing an assignment.

(A) NAME OF ASSIGNEE _____ (B) RESIDENCE: (CITY and STATE OR COUNTRY) _____

Please check the appropriate assignee category or categories (will not be printed on the patent) : Individual Corporation or other private group entity Government

<p>4a. The following fee(s) are submitted:</p> <p><input type="checkbox"/> Issue Fee</p> <p><input type="checkbox"/> Publication Fee (No small entity discount permitted)</p> <p><input type="checkbox"/> Advance Order - # of Copies _____</p>	<p>4b. Payment of Fee(s): (Please first reapply any previously paid issue fee shown above)</p> <p><input type="checkbox"/> A check is enclosed.</p> <p><input type="checkbox"/> Payment by credit card. Form PTO-2038 is attached.</p> <p><input type="checkbox"/> The Director is hereby authorized to charge the required fee(s), any deficiency, or credit any overpayment, to Deposit Account Number _____ (enclose an extra copy of this form).</p>
---	---

5. **Change in Entity Status** (from status indicated above)

- Applicant certifying micro entity status. See 37 CFR 1.29
- Applicant asserting small entity status. See 37 CFR 1.27
- Applicant changing to regular undiscounted fee status.

NOTE: Absent a valid certification of Micro Entity Status (see form PTO/SB/15A and 15B), issue fee payment in the micro entity amount will not be accepted at the risk of application abandonment.

NOTE: If the application was previously under micro entity status, checking this box will be taken to be a notification of loss of entitlement to micro entity status.

NOTE: Checking this box will be taken to be a notification of loss of entitlement to small or micro entity status, as applicable.

NOTE: The Issue Fee and Publication Fee (if required) will not be accepted from anyone other than the applicant; a registered attorney or agent; or the assignee or other party in interest as shown by the records of the United States Patent and Trademark Office.

Authorized Signature _____

Date _____

Typed or printed name _____

Registration No. _____

This collection of information is required by 37 CFR 1.311. The information is required to obtain or retain a benefit by the public which is to file (and by the USPTO to process) an application. Confidentiality is governed by 35 U.S.C. 122 and 37 CFR 1.14. This collection is estimated to take 12 minutes to complete, including gathering, preparing, and submitting the completed application form to the USPTO. Time will vary depending upon the individual case. Any comments on the amount of time you require to complete this form and/or suggestions for reducing this burden, should be sent to the Chief Information Officer, U.S. Patent and Trademark Office, U.S. Department of Commerce, P.O. Box 1450, Alexandria, Virginia 22313-1450. DO NOT SEND FEES OR COMPLETED FORMS TO THIS ADDRESS. SEND TO: Commissioner for Patents, P.O. Box 1450, Alexandria, Virginia 22313-1450.

Under the Paperwork Reduction Act of 1995, no persons are required to respond to a collection of information unless it displays a valid OMB control number.



UNITED STATES PATENT AND TRADEMARK OFFICE

UNITED STATES DEPARTMENT OF COMMERCE
United States Patent and Trademark Office
Address: COMMISSIONER FOR PATENTS
P.O. Box 1450
Alexandria, Virginia 22313-1450
www.uspto.gov

Table with 5 columns: APPLICATION NO., FILING DATE, FIRST NAMED INVENTOR, ATTORNEY DOCKET NO., CONFIRMATION NO.
Row 1: 13/176,771, 07/06/2011, Zhou Ye, 040-13-0052.IUS, 5154
Row 2: 66749, 7590, 06/25/2013, [EXAMINER], [SADIO, INSA]
Row 3: [ART UNIT], [PAPER NUMBER]

DING YU TAN
22114 LEGENDRE RD
RICHMOND, TX 77407

DATE MAILED: 06/25/2013

Determination of Patent Term Adjustment under 35 U.S.C. 154 (b)

(application filed on or after May 29, 2000)

The Patent Term Adjustment to date is 144 day(s). If the issue fee is paid on the date that is three months after the mailing date of this notice and the patent issues on the Tuesday before the date that is 28 weeks (six and a half months) after the mailing date of this notice, the Patent Term Adjustment will be 144 day(s).

If a Continued Prosecution Application (CPA) was filed in the above-identified application, the filing date that determines Patent Term Adjustment is the filing date of the most recent CPA.

Applicant will be able to obtain more detailed information by accessing the Patent Application Information Retrieval (PAIR) WEB site (http://pair.uspto.gov).

Any questions regarding the Patent Term Extension or Adjustment determination should be directed to the Office of Patent Legal Administration at (571)-272-7702. Questions relating to issue and publication fee payments should be directed to the Customer Service Center of the Office of Patent Publication at 1-(888)-786-0101 or (571)-272-4200.

Privacy Act Statement

The Privacy Act of 1974 (P.L. 93-579) requires that you be given certain information in connection with your submission of the attached form related to a patent application or patent. Accordingly, pursuant to the requirements of the Act, please be advised that: (1) the general authority for the collection of this information is 35 U.S.C. 2(b)(2); (2) furnishing of the information solicited is voluntary; and (3) the principal purpose for which the information is used by the U.S. Patent and Trademark Office is to process and/or examine your submission related to a patent application or patent. If you do not furnish the requested information, the U.S. Patent and Trademark Office may not be able to process and/or examine your submission, which may result in termination of proceedings or abandonment of the application or expiration of the patent.

The information provided by you in this form will be subject to the following routine uses:

1. The information on this form will be treated confidentially to the extent allowed under the Freedom of Information Act (5 U.S.C. 552) and the Privacy Act (5 U.S.C. 552a). Records from this system of records may be disclosed to the Department of Justice to determine whether disclosure of these records is required by the Freedom of Information Act.
2. A record from this system of records may be disclosed, as a routine use, in the course of presenting evidence to a court, magistrate, or administrative tribunal, including disclosures to opposing counsel in the course of settlement negotiations.
3. A record in this system of records may be disclosed, as a routine use, to a Member of Congress submitting a request involving an individual, to whom the record pertains, when the individual has requested assistance from the Member with respect to the subject matter of the record.
4. A record in this system of records may be disclosed, as a routine use, to a contractor of the Agency having need for the information in order to perform a contract. Recipients of information shall be required to comply with the requirements of the Privacy Act of 1974, as amended, pursuant to 5 U.S.C. 552a(m).
5. A record related to an International Application filed under the Patent Cooperation Treaty in this system of records may be disclosed, as a routine use, to the International Bureau of the World Intellectual Property Organization, pursuant to the Patent Cooperation Treaty.
6. A record in this system of records may be disclosed, as a routine use, to another federal agency for purposes of National Security review (35 U.S.C. 181) and for review pursuant to the Atomic Energy Act (42 U.S.C. 218(c)).
7. A record from this system of records may be disclosed, as a routine use, to the Administrator, General Services, or his/her designee, during an inspection of records conducted by GSA as part of that agency's responsibility to recommend improvements in records management practices and programs, under authority of 44 U.S.C. 2904 and 2906. Such disclosure shall be made in accordance with the GSA regulations governing inspection of records for this purpose, and any other relevant (i.e., GSA or Commerce) directive. Such disclosure shall not be used to make determinations about individuals.
8. A record from this system of records may be disclosed, as a routine use, to the public after either publication of the application pursuant to 35 U.S.C. 122(b) or issuance of a patent pursuant to 35 U.S.C. 151. Further, a record may be disclosed, subject to the limitations of 37 CFR 1.14, as a routine use, to the public if the record was filed in an application which became abandoned or in which the proceedings were terminated and which application is referenced by either a published application, an application open to public inspection or an issued patent.
9. A record from this system of records may be disclosed, as a routine use, to a Federal, State, or local law enforcement agency, if the USPTO becomes aware of a violation or potential violation of law or regulation.

Notice of Allowability	Application No. 13/176,771	Applicant(s) YE ET AL.	
	Examiner INSA SADIO	Art Unit 2692	AIA (First Inventor to File) Status No

-- The MAILING DATE of this communication appears on the cover sheet with the correspondence address--

All claims being allowable, PROSECUTION ON THE MERITS IS (OR REMAINS) CLOSED in this application. If not included herewith (or previously mailed), a Notice of Allowance (PTOL-85) or other appropriate communication will be mailed in due course. **THIS NOTICE OF ALLOWABILITY IS NOT A GRANT OF PATENT RIGHTS.** This application is subject to withdrawal from issue at the initiative of the Office or upon petition by the applicant. See 37 CFR 1.313 and MPEP 1308.

1. This communication is responsive to Application filed on 07/06/2011.
 A declaration(s)/affidavit(s) under **37 CFR 1.130(b)** was/were filed on _____.
2. An election was made by the applicant in response to a restriction requirement set forth during the interview on _____; the restriction requirement and election have been incorporated into this action.
3. The allowed claim(s) is/are 1,4-12 and 15-22. As a result of the allowed claim(s), you may be eligible to benefit from the **Patent Prosecution Highway** program at a participating intellectual property office for the corresponding application. For more information, please see http://www.uspto.gov/patents/init_events/oph/index.jsp or send an inquiry to PPHfeedback@uspto.gov.
4. Acknowledgment is made of a claim for foreign priority under 35 U.S.C. § 119(a)-(d) or (f).

Certified copies:

- a) All b) Some *c) None of the:
1. Certified copies of the priority documents have been received.
 2. Certified copies of the priority documents have been received in Application No. _____.
 3. Copies of the certified copies of the priority documents have been received in this national stage application from the International Bureau (PCT Rule 17.2(a)).

* Certified copies not received: _____.

Interim copies:

- a) All b) Some c) None of the: Interim copies of the priority documents have been received.

Applicant has THREE MONTHS FROM THE "MAILING DATE" of this communication to file a reply complying with the requirements noted below. Failure to timely comply will result in ABANDONMENT of this application.

THIS THREE-MONTH PERIOD IS NOT EXTENDABLE.

5. CORRECTED DRAWINGS (as "replacement sheets") must be submitted.
 including changes required by the attached Examiner's Amendment / Comment or in the Office action of Paper No./Mail Date _____.
Identifying indicia such as the application number (see 37 CFR 1.84(c)) should be written on the drawings in the front (not the back) of each sheet. Replacement sheet(s) should be labeled as such in the header according to 37 CFR 1.121(d).
6. DEPOSIT OF and/or INFORMATION about the deposit of BIOLOGICAL MATERIAL must be submitted. Note the attached Examiner's comment regarding REQUIREMENT FOR THE DEPOSIT OF BIOLOGICAL MATERIAL.

Attachment(s)

- | | |
|---|---|
| <ol style="list-style-type: none"> 1. <input type="checkbox"/> Notice of References Cited (PTO-892) 2. <input type="checkbox"/> Information Disclosure Statements (PTO/SB/08),
Paper No./Mail Date _____ 3. <input type="checkbox"/> Examiner's Comment Regarding Requirement for Deposit of Biological Material 4. <input type="checkbox"/> Interview Summary (PTO-413),
Paper No./Mail Date _____ | <ol style="list-style-type: none"> 5. <input type="checkbox"/> Examiner's Amendment/Comment 6. <input type="checkbox"/> Examiner's Statement of Reasons for Allowance 7. <input type="checkbox"/> Other _____. |
|---|---|

INSA SADIO
Examiner
Art Unit: 2692

/LUN-YI LAO/
Supervisory Patent Examiner, Art Unit 2692

Search Notes 	Application/Control No. 13176771	Applicant(s)/Patent Under Reexamination YE ET AL.
	Examiner INSA SADIO	Art Unit 2692

CPC- SEARCHED		
Symbol	Date	Examiner

CPC COMBINATION SETS - SEARCHED		
Symbol	Date	Examiner

US CLASSIFICATION SEARCHED			
Class	Subclass	Date	Examiner
345	156-168, 173-183	6/16/2013	/IS/
178	18.01-18.04, 19.01-19.04	6/16/2013	/IS/

SEARCH NOTES		
Search Notes	Date	Examiner
Inventor search	6/16/2013	/IS/

INTERFERENCE SEARCH			
US Class/ CPC Symbol	US Subclass / CPC Group	Date	Examiner
	Searched all of the above	6/16/2013	/IS/

--	--

EAST Search History

EAST Search History (Prior Art)

Ref #	Hits	Search Query	DBs	Default Operator	Plurals	Time Stamp
L1	3355	178/18.01-18.04,19.01-19.04.ccls.	US-PGPUB; USPAT; USOCR; FPRS; EPO; JPO; DERWENT; IBM_TDB	OR	ON	2013/06/16 20:49
L2	40	("5440326" "7236156" "6061611" "7158118" "7414611" "7489298" "7535456" "5898421" "7262760" "7817134" "5138154" "7239301" "20110307173" "7774155" "7924264" "20080096654" "6993451" "8010313" "20090262074").PN.	US-PGPUB; USPAT; USOCR; FPRS; EPO; JPO; DERWENT; IBM_TDB	OR	ON	2013/06/16 20:49
L3	0	1 and L2	US-PGPUB; USPAT; USOCR; FPRS; EPO; JPO; DERWENT; IBM_TDB	OR	ON	2013/06/16 20:49
L4	21165	345/173-183.ccls.	US-PGPUB; USPAT; USOCR; FPRS; EPO; JPO; DERWENT; IBM_TDB	OR	ON	2013/06/16 20:49
L5	2791	178/18.01,18.03,19.01.ccls.	US-PGPUB; USPAT; USOCR; FPRS; EPO; JPO; DERWENT; IBM_TDB	OR	ON	2013/06/16 20:49
L6	22393	L4 L5	US-PGPUB; USPAT; USOCR; FPRS; EPO; JPO; DERWENT; IBM_TDB	OR	ON	2013/06/16 20:49
L7	412	L6 and (orientat\$3 same sens\$3) and (rotat\$3 same sens\$3)and (comput\$3 with process\$4)	US-PGPUB; USPAT; USOCR; FPRS; EPO; JPO; DERWENT; IBM_TDB	OR	ON	2013/06/16 20:49

L8	60	1 and L7	US-PGPUB; USPAT; USOCR; FPRS; EPO; JPO; DERWENT; IBM_TDB	OR	ON	2013/06/16 20:49
S1	76	((ZHOU) near2 (YE)).INV.	US-PGPUB; USPAT	OR	OFF	2012/12/29 20:11
S2	6	((CHIN-LUNG) near2 (LI)).INV.	US-PGPUB; USPAT	OR	OFF	2012/12/29 20:12
S3	52	((SHUN-NAN) near2 (LIOU)).INV.	US-PGPUB; USPAT	OR	OFF	2012/12/29 20:12
S4	118	S1 S2 S3	US-PGPUB; USPAT; USOCR; FPRS; EPO; JPO; DERWENT; IBM_TDB	OR	ON	2012/12/29 20:15
S5	39	("5440326" "7236156" "6061611" "7158118" "7414611" "7489298" "7535456" "5898421" "7262760" "7817134" "5138154" "7239301" "20110307173" "7774155" "7924264" "20080096654" "6993451" "8010313" "20090262074").PN.	US-PGPUB; USPAT; USOCR; FPRS; EPO; JPO; DERWENT; IBM_TDB	OR	ON	2012/12/29 20:16
S6	10	US-6993451-\$.DID. OR US-7774155- \$.DID. OR US-8010313-\$.DID. OR US- 20080096654-\$.DID. OR US-6061611- \$.DID. OR US-7924264-\$.DID. OR US- 7817134-\$.DID. OR US-20090262074- \$.DID. OR US-1994197-\$.DID.	US-PGPUB; USPAT; USOCR	OR	OFF	2012/12/29 20:17
S7	10	US-5138154-\$.DID. OR US-5440326- \$.DID. OR US-5898421-\$.DID. OR US- 7158118-\$.DID. OR US-7236156-\$.DID. OR US-7239301-\$.DID. OR US- 7262760-\$.DID. OR US-7414611-\$.DID. OR US-7489298-\$.DID. OR US- 7535456-\$.DID.	US-PGPUB; USPAT; USOCR	OR	OFF	2012/12/29 20:18
S8	41	S5 S6 S7	US-PGPUB; USPAT; USOCR; FPRS; EPO; JPO; DERWENT; IBM_TDB	OR	ON	2012/12/29 20:18
S9	7	US-6993451-\$.DID. OR US-7774155- \$.DID. OR US-8010313-\$.DID. OR US- 20080096654-\$.DID. OR US-6061611- \$.DID. OR US-7924264-\$.DID. OR US- 7817134-\$.DID.	US-PGPUB; USPAT; USOCR	OR	OFF	2012/12/29 20:19
S10	41	S8 S9	US-PGPUB; USPAT; USOCR; FPRS; EPO; JPO; DERWENT; IBM_TDB	OR	ON	2012/12/29 20:19

S11	21	("5440326" "7489298" "5138154" "7262760" "7158118" "7414611" "5440326" "5898421" "5898421" "7236156" "7262760" "7239301" "7239301" "7489298" "7535456" "5138154" "7158118" "7236156" "7535456" "7414611").PN.	US-PGPUB; USPAT; USOCR; FPRS; EPO; JPO; DERWENT; IBM_TDB	OR	ON	2012/12/29 20:19
S12	41	S5 S6 S8 S9 S10 S11	US-PGPUB; USPAT; USOCR; FPRS; EPO; JPO; DERWENT; IBM_TDB	OR	ON	2012/12/29 20:20
S13	3	12/943934	US-PGPUB; USPAT; USOCR; FPRS; EPO; JPO; DERWENT; IBM_TDB	OR	ON	2012/12/29 20:21
S14	18848	345/156-168.ccls.	US-PGPUB; USPAT; USOCR; FPRS; EPO; JPO; DERWENT; IBM_TDB	OR	ON	2012/12/29 20:21
S15	14	S12 and S14	US-PGPUB; USPAT; USOCR; FPRS; EPO; JPO; DERWENT; IBM_TDB	OR	ON	2012/12/29 20:22
S16	10	S15 and (orient\$3 with sens\$3)	US-PGPUB; USPAT; USOCR; FPRS; EPO; JPO; DERWENT; IBM_TDB	OR	ON	2012/12/29 20:37
S17	11	S15 and (orient\$3 same sens\$3)	US-PGPUB; USPAT; USOCR; FPRS; EPO; JPO; DERWENT; IBM_TDB	OR	ON	2012/12/29 20:37
S18	13	S15 and (orientat\$3 same sens\$3)	US-PGPUB; USPAT; USOCR; FPRS; EPO; JPO; DERWENT; IBM_TDB	OR	ON	2012/12/29 20:39
S19	13	S15 and (orientat\$3 same sens\$3) and (rotat\$3 same sens\$3)	US-PGPUB; USPAT; USOCR; FPRS; EPO; JPO;	OR	ON	2012/12/29 20:41

			DERWENT; IBM_TDB			
S20	11	S15 and (orientat\$3 same sens\$3) and (rotat\$3 same sens\$3)and (comput\$3 with process\$4)	US-PGPUB; USPAT; USOCR; FPRS; EPO; JPO; DERWENT; IBM_TDB	OR	ON	2012/12/29 20:44
S21	0	"20090262074".pn. and (earth same (magnet\$5 magnetometer))	US-PGPUB; USPAT; USOCR; FPRS; EPO; JPO; DERWENT; IBM_TDB	OR	ON	2012/12/29 23:32
S22	0	"20090262074".pn. and (earth same (magnetism magnet\$3 magnetometer))	US-PGPUB; USPAT; USOCR; FPRS; EPO; JPO; DERWENT; IBM_TDB	OR	ON	2012/12/29 23:33
S23	1	"20090262074".pn. and (earth and (magnetism magnet\$3 magnetometer))	US-PGPUB; USPAT; USOCR; FPRS; EPO; JPO; DERWENT; IBM_TDB	OR	ON	2012/12/29 23:34
S24	1	"20090262074".pn. and (earth and (magnetism magnet\$3 magnetometer orbit\$4))	US-PGPUB; USPAT; USOCR; FPRS; EPO; JPO; DERWENT; IBM_TDB	OR	ON	2012/12/29 23:35
S25	1	"20090262074".pn. and (earth and (magnetism magnet\$3 magnetometer orbit\$4 orientat\$3))	US-PGPUB; USPAT; USOCR; FPRS; EPO; JPO; DERWENT; IBM_TDB	OR	ON	2012/12/29 23:36
S26	1	"20090262074".pn. and (earth and (magnetism magnet\$3 magnetometer orbit\$4 orientat\$3 space))	US-PGPUB; USPAT; USOCR; FPRS; EPO; JPO; DERWENT; IBM_TDB	OR	ON	2012/12/29 23:38
S27	1	"20090262074".pn. and (control\$4 with process\$3)	US-PGPUB; USPAT; USOCR; FPRS; EPO; JPO; DERWENT; IBM_TDB	OR	ON	2012/12/29 23:58
S28	1	"20090262074".pn. and (control\$4 with process\$3) and (velocit\$3 and movement)	US-PGPUB; USPAT; USOCR;	OR	ON	2012/12/30 00:17

			FPRS; EPO; JPO; DERWENT; IBM_TDB			
S29	1	"20090262074".pn. and (control\$4 with process\$3) and (velocit\$3 same movement)	US-PGPUB; USPAT; USOCR; FPRS; EPO; JPO; DERWENT; IBM_TDB	OR	ON	2012/12/30 00:17
S30	1	"20090262074".pn. and (control\$4 with process\$3) and (velocit\$3 with movement)	US-PGPUB; USPAT; USOCR; FPRS; EPO; JPO; DERWENT; IBM_TDB	OR	ON	2012/12/30 00:17
S31	21165	345/173-183.ccls.	US-PGPUB; USPAT; USOCR; FPRS; EPO; JPO; DERWENT; IBM_TDB	OR	ON	2013/06/16 20:00
S32	2791	178/18.01,18.03,19.01.ccls.	US-PGPUB; USPAT; USOCR; FPRS; EPO; JPO; DERWENT; IBM_TDB	OR	ON	2013/06/16 20:01
S33	22393	S31 S32	US-PGPUB; USPAT; USOCR; FPRS; EPO; JPO; DERWENT; IBM_TDB	OR	ON	2013/06/16 20:01
S34	412	S33 and (orientat\$3 same sens\$3) and (rotat\$3 same sens\$3)and (comput\$3 with process\$4)	US-PGPUB; USPAT; USOCR; FPRS; EPO; JPO; DERWENT; IBM_TDB	OR	ON	2013/06/16 20:01
S35	469	S33 and (control\$4 with process\$3) and (velocit\$3 with movement)	US-PGPUB; USPAT; USOCR; FPRS; EPO; JPO; DERWENT; IBM_TDB	OR	ON	2013/06/16 20:02
S36	42	S34 and S35	US-PGPUB; USPAT; USOCR; FPRS; EPO; JPO; DERWENT; IBM_TDB	OR	ON	2013/06/16 20:03
S37	0	(refrence and sensor and poiting and	US-PGPUB;	OR	ON	2013/06/16

		device and three and coordinate and device and earth and processor and orientation).clm.	USPAT; USOCR; FPRS; EPO; JPO; DERWENT; IBM_TDB			20:06
S38	0	(reference and sensor and poiting and device and three and coordinate and device and earth and processor and orientation).clm.	US-PGPUB; USPAT; USOCR; FPRS; EPO; JPO; DERWENT; IBM_TDB	OR	ON	2013/06/16 20:06
S39	0	(reference and sensor and poiting and device and three and coordinate and device and processor and orientation).clm.	US-PGPUB; USPAT; USOCR; FPRS; EPO; JPO; DERWENT; IBM_TDB	OR	ON	2013/06/16 20:06
S40	13	(reference and sensor and pointing and device and three and coordinate and device and processor and orientation).clm.	US-PGPUB; USPAT; USOCR; FPRS; EPO; JPO; DERWENT; IBM_TDB	OR	ON	2013/06/16 20:06

EAST Search History (Interference)

Ref #	Hits	Search Query	DBs	Default Operator	Plurals	Time Stamp
S41	13	(reference and sensor and pointing and device and three and coordinate and device and processor and orientation).clm.	US-PGPUB; USPAT; UPAD	OR	ON	2013/06/16 20:07
S42	20	(reference and sensor and pointing and device and three and coordinate and device and processor).clm.	US-PGPUB; USPAT; UPAD	OR	ON	2013/06/16 20:08
S43	20	(reference and sensor and pointing and device and three and coordinate and processor).clm.	US-PGPUB; USPAT; UPAD	OR	ON	2013/06/16 20:08
S44	32	(reference and sensor and pointing and device and coordinate and processor).clm.	US-PGPUB; USPAT; UPAD	OR	ON	2013/06/16 20:08
S45	85	(reference and pointing and device and coordinate and processor).clm.	US-PGPUB; USPAT; UPAD	OR	ON	2013/06/16 20:08

6/16/2013 8:50:34 PM

C:\Users\isadio\Documents\EAST\Workspaces\13176771.wsp

Issue Classification 	Application/Control No. 13176771	Applicant(s)/Patent Under Reexamination YE ET AL.
	Examiner INSA SADIO	Art Unit 2692

<input type="checkbox"/> Claims renumbered in the same order as presented by applicant		<input type="checkbox"/> CPA		<input type="checkbox"/> T.D.		<input type="checkbox"/> R.1.47									
Final	Original	Final	Original	Final	Original	Final	Original	Final	Original	Final	Original	Final	Original	Final	Original
1	1	13	17												
-	2	14	18												
-	3	17	19												
2	4	18	20												
3	5	15	21												
4	6	16	22												
5	7														
6	8														
7	9														
8	10														
9	11														
10	12														
-	13														
-	14														
11	15														
12	16														

/INSA SADIO/ Examiner.Art Unit 2692 (Assistant Examiner)	06/16/2013 (Date)	Total Claims Allowed: 18	
/LUN-YI LAO/ Supervisory Patent Examiner.Art Unit 2692 (Primary Examiner)	06/17/2013 (Date)	O.G. Print Claim(s) 1	O.G. Print Figure 4&9

PATENT

IN THE UNITED STATES PATENT AND TRADEMARK OFFICE

Title: 3D POINTING DEVICE AND METHOD FOR COMPENSATING
ROTATIONS OF THE 3D POINTING DEVICE THEREOF

Appl. No. : 13/176,771 Confirmation No. 5154
Applicant : Zhou Ye et al.
Filing Date : 07/06/2011
TC/A.U. : 2692
Examiner : SADIO, INSA
Docket No. : 040-13-0052.IUS
Customer No. 66749

Mail Stop Amendment
Commissioner for Patents
P.O. Box 1450
Alexandria, Virginia 22313-1450

Amendments

In response to the outstanding Office action, mailed on Jan. 28, 2013, in connection with the above-identified application, kindly amend the subject application as follows and consider the accompanying remarks.

Amendments to the Claims are reflected in the listing of claims, which begins on page **2** of this paper.

Remarks begin on page **9** of this paper.

Amendments to the Claims

This listing of claims will replace all prior versions, and listings, of claims in the application:

Listing of Claims:

1. (currently-amended) A 3D pointing device, comprising:

an orientation sensor, generating an orientation output associated with an orientation of the 3D pointing device associated with three coordinate axes of a global reference frame associated with Earth;

a rotation sensor, generating a rotation output associated with a rotation of the 3D pointing device associated with three coordinate axes of a spatial reference frame associated with the 3D pointing device; and

a first computing processor, using the orientation output and the rotation output to generate a transformed output associated with a fixed reference frame associated with a display device[[.]],

wherein the orientation sensor comprises:

an accelerometer, generating a first signal set comprising axial accelerations associated with movements and rotations of the 3D pointing device in the spatial reference frame;

a magnetometer, generating a second signal set associated with Earth's magnetism; and

a second computing processor, generating the orientation output based on the first signal set, the second signal set and the rotation output or based on the first signal set and the second signal set;

wherein the rotation sensor, the accelerometer, and the magnetometer forming a nine-axis motion sensor module; the 3D pointing device is configured for obtaining one or more resultant deviation including a plurality of deviation angles using a plurality of measured magnetisms M_x , M_y , M_z and a plurality of predicted magnetism M_x' , M_y' and M_z' .

2. (canceled)

3. (canceled)

4. (currently-amended) The 3D pointing device of claim [\[\[3\]\]1](#), wherein the orientation output comprises a yaw angle, a pitch angle, and a roll angle associated with the three coordinate axes of the global reference frame; the first signal set comprises a first axial acceleration, a second axial acceleration, and a third axial acceleration; the second computing processor calculates the pitch angle based on the first axial acceleration, calculates the roll angle based on the second axial acceleration and the pitch angle or based on the third axial acceleration and the pitch angle, and calculates the yaw angle based on the pitch angle, the roll angle, and the second signal set.

5. (original) The 3D pointing device of claim 1, wherein the orientation output provided by the orientation sensor is a rotation matrix, a quaternion, a rotation vector, or comprises three orientation angles.

6. (original) The 3D pointing device of claim 1, wherein the transformed output represents a segment of a movement in a plane in the fixed reference frame

parallel to a screen of the display device.

7. (original) The 3D pointing device of claim 1, wherein the first computing processor obtains an orientation of the display device associated with the global reference frame, obtains an orientation of the 3D pointing device associated with the fixed reference frame based on the orientation output and the orientation of the display device associated with the global reference frame, generates a transformed rotation associated with the fixed reference frame based on the orientation of the 3D pointing device associated with the fixed reference frame and the rotation output, and generates the transformed output based on the transformed rotation.

8. (original) The 3D pointing device of claim 7, wherein when the first computing processor receives a reset signal, the first computing processor records a current orientation output generated by the orientation sensor as the orientation of the display device associated with the global reference frame.

9. (original) The 3D pointing device of claim 8, wherein the current orientation output comprises a yaw angle associated with one of the three coordinate axes of the global reference frame, the first computing processor obtains the orientation of the 3D pointing device associated with the fixed reference frame by subtracting the yaw angle from the orientation output.

10. (original) The 3D pointing device of claim 7, wherein the first computing processor obtains a rotation matrix from the orientation of the 3D pointing device associated with the fixed reference frame, and multiplies the rotation

matrix and the rotation output together to generate the transformed rotation.

11. (original) The 3D pointing device of claim 10, wherein the transformed rotation comprises a first angular velocity, a second angular velocity, and a third angular velocity associated with three coordinate axes of the fixed reference frame; the transformed output comprises a first movement component and a second movement component associated with two of the three coordinate axes of the fixed reference frame; the first computing processor multiplies the second angular velocity by a scale factor to generate the second movement component and multiplies the third angular velocity by the scale factor to generate the first movement component.

12. (currently-amended) A method for compensating rotations of a 3D pointing device, comprising:

generating an orientation output associated with an orientation of the 3D pointing device associated with three coordinate axes of a global reference frame associated with Earth;

generating a first signal set comprising axial accelerations associated with movements and rotations of the 3D pointing device in the spatial reference frame;

generating a second signal set associated with Earth's magnetism;
generating the orientation output based on the first signal set, the second signal set and the rotation output or based on the first signal set and the second signal set;

generating a rotation output associated with a rotation of the 3D pointing device associated with three coordinate axes of a spatial reference frame associated with the 3D pointing device; and

using the orientation output and the rotation output to generate a transformed output associated with a fixed reference frame associated with a display device[[.]], wherein the orientation output and the rotation output is generated by a nine-axis motion sensor module; obtaining one or more resultant deviation including a plurality of deviation angles using a plurality of measured magnetisms M_x , M_y , M_z and a plurality of predicted magnetism M_x' , M_y' and M_z' for the second signal set.

13. (canceled)

14. (canceled)

15. (currently amended) The method of claim [[14]]12, wherein the orientation output comprises a yaw angle, a pitch angle, and a roll angle associated with the three coordinate axes of the global reference frame; the first signal set comprises a first axial acceleration, a second axial acceleration, and a third axial acceleration; the step of generating the orientation output based on the first signal set and the second signal set comprises:

calculating the pitch angle based on the first axial acceleration;

calculating the roll angle based on the second axial acceleration and the pitch angle or based on the third axial acceleration and the pitch angle; and

calculating the yaw angle based on the pitch angle, the roll angle, and the second signal set.

16. (original) The method of claim 12, wherein the orientation output is a rotation matrix, a quaternion, a rotation vector, or comprises three orientation angles.

17. (original) The method of claim 12, wherein the transformed output represents a segment of a movement in a plane in the fixed reference frame parallel to a screen of the display device.

18. (original) The method of claim 12, wherein the step of generating the transformed output comprises:

- obtaining an orientation of the display device associated with the global reference frame;

- obtaining an orientation of the 3D pointing device associated with the fixed reference frame based on the orientation output and the orientation of the display device associated with the global reference frame;

- generating a transformed rotation associated with the fixed reference frame based on the orientation of the 3D pointing device associated with the fixed reference frame and the rotation output; and

- generating the transformed output based on the transformed rotation.

19. (original) The method of claim 18, wherein the step of obtaining the orientation of the display device associated with the global reference frame comprises:

- recording a current orientation output as the orientation of the display device associated with the global reference frame in response to a reset signal.

20. (original) The method of claim 19, wherein the current orientation output comprises a yaw angle associated with one of the three coordinate axes of the global reference frame, and the step of obtaining the orientation of the 3D pointing device associated with the fixed reference frame comprises: obtaining the orientation of the 3D pointing device associated with the fixed reference frame by subtracting the yaw angle from the orientation output.

21. (original) The method of claim 18, wherein the step of generating the transformed rotation comprises:

obtaining a rotation matrix from the orientation of the 3D pointing device associated with the fixed reference frame; and

multiplying the rotation matrix and the rotation output together to generate the transformed rotation.

22. (original) The method of claim 21, wherein the transformed rotation comprises a first angular velocity, a second angular velocity, and a third angular velocity associated with three coordinate axes of the fixed reference frame; the transformed output comprises a first movement component and a second movement component associated with two of the three coordinate axes of the fixed reference frame; the step of generating the transformed output based on the transformed rotation comprises:

multiplying the second angular velocity by a scale factor to generate the second movement component; and

multiplying the third angular velocity by the scale factor to generate the first movement component.

REMARKS

Applicant has amended claims 1, 4, 12 and 15, and cancelled claims 2, 3, 13, and 14 without prejudice. The amendments to the claims are based on what was previously expressly disclosed or inherent in the specification as originally filed. No new matter is added. Applicant respectfully submits that all the hitherto pending claims are now placed in position for allowance. Detailed reasons for allowance are provided below.

Double Patenting Rejections under 37 CFR 1.78(b)

Claims 1-22 of this application conflict with claims 1-20 of Application No. 12/943,034. Applicant is required to either cancel the conflicting claims from all but one application or maintain a clear line of demarcation between the applications.

In response, Applicant submits that claim 1 is hereby amended to include new limitations of “a nine-axis motion sensor module” and “the 3D pointing device is configured for obtaining one or more resultant deviation including a plurality of deviation angles using a plurality of **measured magnetisms** Mx, My, Mz and a plurality of **predicted magnetism** Mx', My' and Mz'”, and claim 12 is hereby amended to include new limitations of “wherein the orientation output and the rotation output is generated by a nine-axis motion sensor module” and “obtaining one or more resultant deviation including a plurality of deviation angles using a plurality of measured magnetisms Mx, My, Mz and a plurality of predicted magnetism Mx', My' and Mz' for the second signal set” to fully patentably differentiate and provide clear line of demarcation between this application and Application No. 12/943,034.

Applicant submits that Application No. 12/943,034 includes the claimed subject matter of a six-axis motion sensor module without having and using measured magnetisms and predicted magnetisms.

Based on the amendments to claims 1 and 12, Applicant submits that the double patenting rejections are overcome.

Claim Rejections under 35 U.S.C. §103

Claims 1-22 are rejected under 35 U.S.C. 103(a) as being unpatentable over Nasiri et al. (20090262074), hereinafter referred to as Nasiri.

In response, regarding claim 1,

Applicant submits that [0059] and [0071] of the specification of instant application expressly recites features regarding the motion sensor module's magnetometer signals used to facilitate the obtaining of the resultant deviation including deviation angles in 3D reference, in which measured magnetisms M_x , M_y , M_z are obtained, and predicted magnetism M_x' , M_y' and M_z' are calculated and obtained.

Applicant submits the limitations of amended claim 1 which includes of (1) wherein the rotation sensor, the accelerometer, and the magnetometer forming a nine-axis motion sensor module; and (2) obtaining resultant deviation including deviation angles using a plurality of measured magnetisms M_x , M_y , M_z , and a plurality of predicted magnetism M_x' , M_y' and M_z' are patentable over Nasiri based on the following traversal.

Regarding amended claim 1, Applicant submits that Nasiri fails to teach or

suggest of having orientation associated or **defined with respect to the global reference frame**. Referring to [0145] of Nasiri, which recites “In one embodiment, the gyroscopes and accelerometers can be combined in a sensor fusion algorithm in order to provide a rotation matrix, quaternion, or Euler angle representation of the devices orientation in space. This orientation can be mapped directly or with constraints to a **virtual world** shown in the display of the device.” And to [0123] of Naziri, which recites that “ In the present invention, a yaw gyroscope can be used to control portrait and landscape orientation in this case or horizontal screen orientation.” Therefore, the orientation taught in Nasiri **is with respect to spatial reference frame, and therefore fails to be “associated with three coordinate axes of a global reference frame** associated with Earth” as claimed in claim 1.

Applicant submits the claimed invention for amended claim 1 for the 3D pointing device adopts a nine-axis motion sensor module with an **enhanced comparison** method or model for **eliminating accumulated errors** of said nine-axis motion sensor module to obtain **deviation angles** corresponding to movements and rotations of said electronic device in a spatial pointer reference frame. In other words, the claimed invention for amended claim 1 for the 3D pointing device of the present invention is capable of accurately outputting the deviation angles including yaw, pitch and roll angles in a 3D spatial pointer reference frame of the 3D pointing device to eliminate or reduce accumulated errors and noises generated over time in a dynamic environment.

Comparing to the specification of present application in [0013], which is reproduced as follow: “[0013] According to another example embodiment of

the present invention, an electronic device capable of generating 3D deviation angles and for use in for example computers, motion detection or navigation is provided. The electronic device may utilize a nine-axis motion sensor module with an **enhanced comparison** method or model for **eliminating accumulated errors** of said nine-axis motion sensor module to obtain **deviation angles** corresponding to movements and rotations of said electronic device in a spatial pointer reference frame. The comparison method or model may be advantageously provided by comparing signals from the abovementioned nine-axis motion sensor module capable of detecting rotation rates or angular velocities of the electronic device about all of the X_P , Y_P and Z_P axes as well as axial accelerations and ambient magnetism including such as earth's magnetic field or that of other planets of the electronic device along all of the X_P , Y_P and Z_P axes such that **deviation angles of the resultant deviation** of the electronic device of the present invention may be preferably obtained or outputted **in an absolute manner**. In other words, the present invention is capable of accurately outputting the abovementioned deviation angles including yaw, pitch and roll angles in a 3D spatial pointer reference frame of the 3D pointing device to eliminate or reduce accumulated errors and noises generated over time in a dynamic environment including conditions such as being subject to a combination of continuous movements, rotations, external gravity forces, magnetic field and additional extra accelerations in multiple directions or movement and rotations that are continuously nonlinear with respect to time; and furthermore, based on the deviation angles being compensated and accurately outputted in 3D spatial reference frame may be further mapped onto or translated into another reference frame such as the abovementioned display frame, for example a reference in two-dimension

(2D).” (emphasis added), Applicant submits that Nasiri teaches the following in [0068]: “Having other algorithms that filter out hand shake and reduce drift may also be used to improve the usability of the device.” and Nasiri teaches the following in [0049]: “Some implementations may employ more than three gyroscopes, for example to enhance accuracy, increase performance, or improve reliability. Some implementations may employed more than three accelerometers, for example to enhance accuracy, increase performance, or improve reliability”.

Based on the above teachings from Naziri, it can be deduced that Naziri teaches away from the above **enhanced comparison** method for **eliminating accumulated errors** of nine-axis motion sensor module to obtain **deviation angles** corresponding to movements and rotations of said electronic device in a spatial pointer reference frame, **by teaching instead**, on using algorithms for filtering out hand shake, and using more than 3 gyroscopes and/or more than 3 accelerometers for improving accuracy and performance.

Applicant further submits that, Nasiri **only briefly** describes about “magnetometers” in [0053] and [0067], as being reproduced below as follows:

[0053]: “For example, sensors such one or more barometers, compasses or magnetometers, temperature sensors, optical sensors (such as a camera sensor, infrared sensor, etc.), ultrasonic sensors, radio frequency sensors, or other types of sensors can be provided. For example, a compass or **magnetometer sensor can provide an additional one, two, or three axes of sensing, such as two horizontal vectors and a third vertical**

vector." (emphasis added)

[0067]: "These control signals may be derived only from gyroscopes of the device, or they may be derived from a combination of any of gyroscopes, accelerometers, and magnetometers of the device as the output of a sensor fusion algorithm (e.g., an algorithm combining inputs from multiple sensors to provide more robust sensing, an example of which is described in copending U.S. patent application Ser. No. 12/252,322, incorporated herein by reference)."

Based on the above reproduced passages from Nasiri, it can be deduced that Nasiri fails to disclose or teach of **calculating resultant deviations based upon axial accelerations and magnetisms** as claimed in amended claim 1.

Applicant submits that Nasiri fails to disclose or teach of **a nine-axis motion sensor module**, but instead, Nasiri teaches a 6-axis sensing device being provided for providing sensing in six degrees of freedom, and teaching also the following: In embodiments with more than three gyroscopes and/or more than three accelerometers, additional degrees of freedom (or sensing axes) can be provided, and/or additional sensor input can be provided for each of the six axis of motion.

Regarding claim 12, claim 12 is amended to include the similar or substantially the same patentable limitations that have been discussed above under amended claim 1, therefore, amended claim 12 should also be patentable and allowable over Nasiri based on the same reasons as that of

claim 1.

Conclusion

Applicant submits that the amendments made herein to claims 1 and 12 are sufficient for overcoming rejections under 35 U.S.C. 103(a) as being unpatentable over Nasiri.

Since dependent claims 4-11 depend on claim 1, and dependent claims 15-22 depend on claim 12, upon allowance of independent claims 1 and 12, dependent claims 4-11 and dependent claims 15-22 should also be patentable and allowable over Nasiri, respectively.

Therefore, Applicant respectfully requests that a timely Notice of Allowance be issued for the instant application.

Respectfully yours,

 /Ding Yu Tan/

Ding Yu Tan, Reg. # 58812

Tel 281-668-8988

Date: April 17, 2013

Electronic Acknowledgement Receipt

EFS ID:	15548171
Application Number:	13176771
International Application Number:	
Confirmation Number:	5154
Title of Invention:	3D POINTING DEVICE AND METHOD FOR COMPENSATING ROTATIONS OF THE 3D POINTING DEVICE THEREOF
First Named Inventor/Applicant Name:	Zhou Ye
Customer Number:	66749
Filer:	Ding Yu Tan
Filer Authorized By:	
Attorney Docket Number:	040-13-0052.IUS
Receipt Date:	17-APR-2013
Filing Date:	06-JUL-2011
Time Stamp:	22:45:05
Application Type:	Utility under 35 USC 111(a)

Payment information:

Submitted with Payment	no
------------------------	----

File Listing:

Document Number	Document Description	File Name	File Size(Bytes)/ Message Digest	Multi Part /.zip	Pages (if appl.)
1		201011_D_US_OA_Response_USPTO.pdf	4114407 <small>3eab563e876c2df7dfc5c68592263e31456d739d</small>	yes	15

Multipart Description/PDF files in .zip description			
Document Description		Start	End
Amendment/Req. Reconsideration-After Non-Final Reject		1	1
Claims		2	8
Applicant Arguments/Remarks Made in an Amendment		9	15

Warnings:

Information:

Total Files Size (in bytes):	4114407
-------------------------------------	---------

This Acknowledgement Receipt evidences receipt on the noted date by the USPTO of the indicated documents, characterized by the applicant, and including page counts, where applicable. It serves as evidence of receipt similar to a Post Card, as described in MPEP 503.

New Applications Under 35 U.S.C. 111

If a new application is being filed and the application includes the necessary components for a filing date (see 37 CFR 1.53(b)-(d) and MPEP 506), a Filing Receipt (37 CFR 1.54) will be issued in due course and the date shown on this Acknowledgement Receipt will establish the filing date of the application.

National Stage of an International Application under 35 U.S.C. 371

If a timely submission to enter the national stage of an international application is compliant with the conditions of 35 U.S.C. 371 and other applicable requirements a Form PCT/DO/EO/903 indicating acceptance of the application as a national stage submission under 35 U.S.C. 371 will be issued in addition to the Filing Receipt, in due course.

New International Application Filed with the USPTO as a Receiving Office

If a new international application is being filed and the international application includes the necessary components for an international filing date (see PCT Article 11 and MPEP 1810), a Notification of the International Application Number and of the International Filing Date (Form PCT/RO/105) will be issued in due course, subject to prescriptions concerning national security, and the date shown on this Acknowledgement Receipt will establish the international filing date of the application.

Under the Paperwork Reduction Act of 1995, no persons are required to respond to a collection of information unless it displays a valid OMB control number.

PATENT APPLICATION FEE DETERMINATION RECORD Substitute for Form PTO-875	Application or Docket Number 13/176,771	Filing Date 07/06/2011	<input type="checkbox"/> To be Mailed
---	---	----------------------------------	---------------------------------------

APPLICATION AS FILED – PART I			OTHER THAN SMALL ENTITY			
	(Column 1)	(Column 2)	SMALL ENTITY <input checked="" type="checkbox"/>	OR		
FOR	NUMBER FILED	NUMBER EXTRA	RATE (\$)	FEE (\$)	RATE (\$)	FEE (\$)
<input type="checkbox"/> BASIC FEE <small>(37 CFR 1.16(a), (b), or (c))</small>	N/A	N/A	N/A		N/A	
<input type="checkbox"/> SEARCH FEE <small>(37 CFR 1.16(k), (j), or (m))</small>	N/A	N/A	N/A		N/A	
<input type="checkbox"/> EXAMINATION FEE <small>(37 CFR 1.16(o), (p), or (q))</small>	N/A	N/A	N/A		N/A	
TOTAL CLAIMS <small>(37 CFR 1.16(j))</small>	minus 20 =	*	X \$ =	OR	X \$ =	
INDEPENDENT CLAIMS <small>(37 CFR 1.16(h))</small>	minus 3 =	*	X \$ =		X \$ =	
<input type="checkbox"/> APPLICATION SIZE FEE <small>(37 CFR 1.16(s))</small>	If the specification and drawings exceed 100 sheets of paper, the application size fee due is \$250 (\$125 for small entity) for each additional 50 sheets or fraction thereof. See 35 U.S.C. 41(a)(1)(G) and 37 CFR 1.16(s).					
<input type="checkbox"/> MULTIPLE DEPENDENT CLAIM PRESENT <small>(37 CFR 1.16(j))</small>						
			TOTAL		TOTAL	

* If the difference in column 1 is less than zero, enter "0" in column 2.

APPLICATION AS AMENDED – PART II					OTHER THAN SMALL ENTITY			
	(Column 1)	(Column 2)	(Column 3)					
AMENDMENT	04/17/2013	CLAIMS REMAINING AFTER AMENDMENT	HIGHEST NUMBER PREVIOUSLY PAID FOR	PRESENT EXTRA	RATE (\$)	ADDITIONAL FEE (\$)	RATE (\$)	ADDITIONAL FEE (\$)
	Total <small>(37 CFR 1.16(i))</small>	* 18	Minus ** 20	= 0	X \$40 =	0	OR	X \$ =
	Independent <small>(37 CFR 1.16(h))</small>	* 2	Minus *** 3	= 0	X \$210 =	0	OR	X \$ =
	<input type="checkbox"/> Application Size Fee <small>(37 CFR 1.16(s))</small>						OR	
	<input type="checkbox"/> FIRST PRESENTATION OF MULTIPLE DEPENDENT CLAIM <small>(37 CFR 1.16(j))</small>						OR	
					TOTAL ADD'L FEE	0	OR	TOTAL ADD'L FEE

	(Column 1)	(Column 2)	(Column 3)					
AMENDMENT		CLAIMS REMAINING AFTER AMENDMENT	HIGHEST NUMBER PREVIOUSLY PAID FOR	PRESENT EXTRA	RATE (\$)	ADDITIONAL FEE (\$)	RATE (\$)	ADDITIONAL FEE (\$)
	Total <small>(37 CFR 1.16(i))</small>	*	Minus **	=	X \$ =		OR	X \$ =
	Independent <small>(37 CFR 1.16(h))</small>	*	Minus ***	=	X \$ =		OR	X \$ =
	<input type="checkbox"/> Application Size Fee <small>(37 CFR 1.16(s))</small>						OR	
	<input type="checkbox"/> FIRST PRESENTATION OF MULTIPLE DEPENDENT CLAIM <small>(37 CFR 1.16(j))</small>						OR	
					TOTAL ADD'L FEE		OR	TOTAL ADD'L FEE

* If the entry in column 1 is less than the entry in column 2, write "0" in column 3.
 ** If the "Highest Number Previously Paid For" IN THIS SPACE is less than 20, enter "20".
 *** If the "Highest Number Previously Paid For" IN THIS SPACE is less than 3, enter "3".
 The "Highest Number Previously Paid For" (Total or Independent) is the highest number found in the appropriate box in column 1.

Legal Instrument Examiner:
 /TERRY MALLOY/

This collection of information is required by 37 CFR 1.16. The information is required to obtain or retain a benefit by the public which is to file (and by the USPTO to process) an application. Confidentiality is governed by 35 U.S.C. 122 and 37 CFR 1.14. This collection is estimated to take 12 minutes to complete, including gathering, preparing, and submitting the completed application form to the USPTO. Time will vary depending upon the individual case. Any comments on the amount of time you require to complete this form and/or suggestions for reducing this burden, should be sent to the Chief Information Officer, U.S. Patent and Trademark Office, U.S. Department of Commerce, P.O. Box 1450, Alexandria, VA 22313-1450. DO NOT SEND FEES OR COMPLETED FORMS TO THIS ADDRESS. **SEND TO: Commissioner for Patents, P.O. Box 1450, Alexandria, VA 22313-1450.**

If you need assistance in completing the form, call 1-800-PTO-9199 and select option 2.



UNITED STATES PATENT AND TRADEMARK OFFICE

UNITED STATES DEPARTMENT OF COMMERCE
United States Patent and Trademark Office
Address: COMMISSIONER FOR PATENTS
P.O. Box 1450
Alexandria, Virginia 22313-1450
www.uspto.gov

APPLICATION NUMBER	FILING OR 371(C) DATE	FIRST NAMED APPLICANT	ATTY. DOCKET NO./TITLE
13/176,771	07/06/2011	Zhou Ye	35822-US-PA-0P-2

CONFIRMATION NO. 5154

POA ACCEPTANCE LETTER



66749
FORESIGHT IP
DING YU TAN
14F., No.111, Songjiang Rd
Unit B03
Taipei,
TAIWAN

Date Mailed: 04/03/2013

NOTICE OF ACCEPTANCE OF POWER OF ATTORNEY

This is in response to the Power of Attorney filed 03/18/2013.

The Power of Attorney in this application is accepted. Correspondence in this application will be mailed to the above address as provided by 37 CFR 1.33.

/sleutchit/

Office of Data Management, Application Assistance Unit (571) 272-4000, or (571) 272-4200, or 1-888-786-0101



UNITED STATES PATENT AND TRADEMARK OFFICE

UNITED STATES DEPARTMENT OF COMMERCE
United States Patent and Trademark Office
Address: COMMISSIONER FOR PATENTS
P.O. Box 1450
Alexandria, Virginia 22313-1450
www.uspto.gov

APPLICATION NUMBER	FILING OR 371(C) DATE	FIRST NAMED APPLICANT	ATTY. DOCKET NO./TITLE
13/176,771	07/06/2011	Zhou Ye	35822-US-PA-0P-2

CONFIRMATION NO. 5154

POWER OF ATTORNEY NOTICE

31561
JIANQ CHYUN INTELLECTUAL PROPERTY OFFICE
7 FLOOR-1, NO. 100
ROOSEVELT ROAD, SECTION 2
TAIPEI, 100
TAIWAN



Date Mailed: 04/03/2013

NOTICE REGARDING CHANGE OF POWER OF ATTORNEY

This is in response to the Power of Attorney filed 03/18/2013.

- The Power of Attorney to you in this application has been revoked by the assignee who has intervened as provided by 37 CFR 3.71. Future correspondence will be mailed to the new address of record(37 CFR 1.33).

/sleutchit/

Office of Data Management, Application Assistance Unit (571) 272-4000, or (571) 272-4200, or 1-888-786-0101

Applicant Initiated Interview Request Form

Application No.: 13176771 First Named Applicant: Zhou Ye
 Examiner: SADIO, INSA Art Unit: 2692 Status of Application: Non-final Rejection

Tentative Participants:

(1) Examiner SADIO, INSA (2) Ding Tan
 (3) _____ (4) _____

Proposed Date of Interview: 2013 Apr. 2~16 Proposed Time: 10 AM (AM/PM)

Type of Interview Requested:

(1) Telephonic (2) Personal (3) Video Conference

Exhibit To Be Shown or Demonstrated: YES NO

If yes, provide brief description: _____

Issues To Be Discussed

Issues (Rej., Obj., etc)	Claims/ Fig. #s	Prior Art	Discussed	Agreed	Not Agreed
(1) _____	_____	_____	[]	[]	[]
(2) _____	_____	_____	[]	[]	[]
(3) _____	_____	_____	[]	[]	[]
(4) _____	_____	_____	[]	[]	[]

Continuation Sheet Attached Proposed Amendment or Arguments Attached

Brief Description of Arguments to be Presented: _____

Please kindly refer to the attached 5 pages for proposed arguments and amendments discussion items, thank you.

An interview was conducted on the above-identified application on _____

NOTE: This form should be completed and filed by applicant in advance of the interview (see MPEP § 713.01). If this form is signed by a registered practitioner not of record, the Office will accept this as an indication that he or she is authorized to conduct an interview on behalf of the principal (37 CFR 1.32(a)(3)) pursuant to 37 CFR 1.34. This is not a power of attorney to any above named practitioner. See the Instruction Sheet for this form, which is incorporated by reference. By signing this form, applicant or practitioner is certifying that he or she has read the Instruction Sheet. After the interview is conducted, applicant is advised to file a statement of the substance of this interview (37 CFR 1.133(b)) as soon as possible. This application will not be delayed from issue because of applicant's failure to submit a written record of this interview.

/Ding Yu Tan/

Applicant/Applicant's Representative Signature

Ding Yu Tan

Typed/Printed Name of Applicant or Representative

58812

Registration Number, if applicable

Examiner/SPE Signature

This collection of information is required by 37 CFR 1.133. The information is required to obtain or retain a benefit by the public which is to file (and by the USPTO to process) an application. Confidentiality is governed by 35 U.S.C. 122 and 37 CFR 1.11 and 1.14. This collection is estimated to take 24 minutes to complete, including gathering, preparing, and submitting the completed application form to the USPTO. Time will vary depending upon the individual case. Any comments on the amount of time you require to complete this form and/or suggestions for reducing this burden, should be sent to the Chief Information Officer, U.S. Patent and Trademark Office, U.S. Department of Commerce, P.O. Box 1450, Alexandria, VA 22313-1450. DO NOT SEND FEES OR COMPLETED FORMS TO THIS ADDRESS. SEND TO: Commissioner for Patents, P.O. Box 1450, Alexandria, VA 22313-1450.

If you need assistance in completing the form, call 1-800-PTO-9199 and select option 2.

PATENT

IN THE UNITED STATES PATENT AND TRADEMARK OFFICE

Title: 3D POINTING DEVICE AND METHOD FOR COMPENSATING
ROTATIONS OF THE 3D POINTING DEVICE THEREOF

Appl. No. : 13/176,771 Confirmation No. 5154
Applicant : Zhou Ye et al.
Filing Date : 07/06/2011
TC/A.U. : 2692
Examiner : SADIO, INSA
Docket No. : 040-13-0052.IUS
Customer No. 66749

Continuation Sheets/ Interview Agenda

Examiner Interview Requestor: Ding Yu Tan, reg. # 58812 (referred herein below as Applicant rep.)

Rejections to be discussed: 35 U.S.C. 103(a) as being unpatentable over Nasiri et. al. (2009/0262074), hereinafter referred to as Nasiri.

Reference to be discussed: Nasiri et. al. (2009/0262074), hereinafter referred to as Nasiri.

Claims to be discussed during interview: Claims 1, 3, 4, 7, 8, and 9

Proposed Arguments and Amendments For Discussion During Interview

A) Regarding claims 1, 4, 7, 8, and 9, Applicant rep. submits that Narizi fails to teach or suggest of having orientation associated or **defined with respect to the global reference frame.**

Referring to [0145] of Naziri, which recites "In one embodiment, the

gyroscopes and accelerometers can be combined in a sensor fusion algorithm in order to provide a rotation matrix, quaternion, or Euler angle representation of the devices orientation in space. This orientation can be mapped directly or with constraints to a **virtual world** shown in the display of the device.” And to [0123] of Naziri, which recites that “ In the present invention, a yaw gyroscope can be used to control portrait and landscape orientation in this case or horizontal screen orientation.”

Therefore, the orientation taught in Naziri **is with respect to spatial reference frame, and therefore fails to be “associated with three coordinate axes of a global reference frame** associated with Earth” as claimed in claim 1, and fails to teach or disclose of “wherein the orientation output comprises a yaw angle, a pitch angle, and a roll angle associated with the three coordinate axes of the global reference frame” as claimed in claim 4, and “wherein the first computing processor obtains an orientation of the display device associated with the global reference frame” of claim 7, and “the first computing processor records a current orientation output generated by the orientation sensor as the orientation of the display device associated with the global reference frame” of claim 8, and “wherein the current orientation output comprises a yaw angle associated with one of the three coordinate axes of the global reference frame” of claim 9.

B) Although not currently recited in the existing claims, Applicant rep. assert the claimed invention for claim 1 for the 3D pointing device inherently uses nine-axis motion sensor module with an **enhanced comparison** method or model for **eliminating accumulated errors** of said nine-axis motion sensor module to obtain **deviation angles** corresponding to movements and rotations of said electronic device in a spatial pointer reference frame.

In other words, the claimed invention for claim 1 for the 3D pointing device of the present invention is capable of accurately outputting the deviation angles including yaw, pitch and roll angles in a 3D spatial pointer reference frame of the 3D pointing device to eliminate or reduce accumulated errors and noises generated over time in a dynamic environment.

Refer to the present specification in [0013], which recites as follow:

“[0013] According to another example embodiment of the present invention, an

electronic device capable of generating 3D deviation angles and for use in for example computers, motion detection or navigation is provided. The electronic device may utilize a nine-axis motion sensor module with an **enhanced comparison** method or model for **eliminating accumulated errors** of said nine-axis motion sensor module to obtain **deviation angles** corresponding to movements and rotations of said electronic device in a spatial pointer reference frame. The comparison method or model may be advantageously provided by comparing signals from the abovementioned nine-axis motion sensor module capable of detecting rotation rates or angular velocities of the electronic device about all of the X_P , Y_P and Z_P axes as well as axial accelerations and ambient magnetism including such as earth's magnetic field or that of other planets of the electronic device along all of the X_P , Y_P and Z_P axes such that **deviation angles of the resultant deviation** of the electronic device of the present invention may be preferably obtained or outputted **in an absolute manner**. In other words, the present invention is capable of accurately outputting the abovementioned deviation angles including yaw, pitch and roll angles in a 3D spatial pointer reference frame of the 3D pointing device to eliminate or reduce accumulated errors and noises generated over time in a dynamic environment including conditions such as being subject to a combination of continuous movements, rotations, external gravity forces, magnetic field and additional extra accelerations in multiple directions or movement and rotations that are continuously nonlinear with respect to time; and furthermore, based on the deviation angles being compensated and accurately outputted in 3D spatial reference frame may be further mapped onto or translated into another reference frame such as the abovementioned display frame, for example a reference in two-dimension (2D).”
(emphasis added)

On the other hand, Applicant rep. submits that Nasiri teaches the following:

Having other algorithms that filter out hand shake and reduce drift may also be used to improve the usability of the device. Some implementations may employ more than three gyroscopes, for example to enhance accuracy, increase performance, or improve reliability. Some implementations may employed more than three accelerometers, for example to enhance accuracy, increase performance, or improve reliability.

Based on the above teachings from Naziri, it can be deduced that Naziri

teaches away from the above **enhanced comparison** method for **eliminating accumulated errors** of nine-axis motion sensor module to obtain **deviation angles** corresponding to movements and rotations of said electronic device in a spatial pointer reference frame, **by having focused instead**, on using algorithms for filtering out hand shake, and using more than 3 gyroscopes and/or more than 3 accelerometers for improving accuracy and performance.

Pending discussion results based on the above argument, one or more claim amendment possibilities consistent with the above argument may be further discussed during the interview.

C) Referring to claim 3, and [0015] of instant application which recites in part the following:

processor. The processor is capable of compensating the accumulated errors associated with the resultant deviation in relation to the signals of the abovementioned nine-axis motion sensor module of the 3D pointing device subject to movements and rotations in a spatial reference frame and in a dynamic environment by performing a data comparison to compare signals of rotation sensor related to angular velocities with the ones of accelerometer related to axial accelerations and the ones of magnetometer related to magnetism such that the resultant deviation corresponding to the movements and rotations of the 3D pointing device in the 3D spatial reference frame may be obtained accurately over time in the dynamic environments.

Applicant rep. submits that, Nasiri **only briefly talks about** “magnetometers” as follows:

For example, sensors such one or more barometers, compasses or magnetometers, temperature sensors, optical sensors (such as a camera sensor, infrared sensor, etc.), ultrasonic sensors, radio frequency sensors, or other types of sensors can be provided. For example, a compass or **magnetometer sensor can provide an additional one, two, or three axes of sensing, such as two horizontal vectors and a third vertical vector.**

These control signals may be derived only from gyroscopes of the device, or they may be derived from a combination of any of gyroscopes, accelerometers, and magnetometers of the device as the output of a sensor fusion algorithm (e.g., an algorithm combining inputs from multiple sensors to provide more robust sensing, an example of which is described in copending U.S. patent application Ser. No. 12/252,322, incorporated herein by reference).

Based on the above passages from Nasiri, it can be deduced that Nasiri fails to disclose or teach of **calculating resultant deviations based upon axial accelerations and magnetisms**.

Pending discussion results based on the above argument, one or more claim amendment possibilities consistent with the above argument may be further discussed during the interview.

D) Further regarding Claim 3, Applicant rep. submits that the claimed invention of claim 3 inherently discloses of nine-axis motion sensor, whereas, Nasiri teaches instead, of 6-axis sensing device being provided for providing sensing in six degrees of freedom, and the following: In embodiments with more than three gyroscopes and/or more than three accelerometers, additional degrees of freedom (or sensing axes) can be provided, and/or additional sensor input can be provided for each of the six axis of motion.

Upon making further claim amendments to claim 3 which are to be discussed during interview, Applicant rep. submits that Nasiri fails to disclose or suggest of **enabling and fully describing the nine-axis** motion sensor of claim 3.

Electronic Acknowledgement Receipt

EFS ID:	15385725
Application Number:	13176771
International Application Number:	
Confirmation Number:	5154
Title of Invention:	3D POINTING DEVICE AND METHOD FOR COMPENSATING ROTATIONS OF THE 3D POINTING DEVICE THEREOF
First Named Inventor/Applicant Name:	Zhou Ye
Customer Number:	66749
Filer:	Ding Yu Tan
Filer Authorized By:	
Attorney Docket Number:	35822-US-PA-0P-2
Receipt Date:	29-MAR-2013
Filing Date:	06-JUL-2011
Time Stamp:	02:21:01
Application Type:	Utility under 35 USC 111(a)

Payment information:

Submitted with Payment	no
------------------------	----

File Listing:

Document Number	Document Description	File Name	File Size(Bytes)/ Message Digest	Multi Part /.zip	Pages (if appl.)
1	Letter Requesting Interview with Examiner	201011-D-US-interview.pdf	2222552 <small>0764db80692647cf281b686beada2285dd4b4a8a</small>	no	6

Warnings:

Information:

This Acknowledgement Receipt evidences receipt on the noted date by the USPTO of the indicated documents, characterized by the applicant, and including page counts, where applicable. It serves as evidence of receipt similar to a Post Card, as described in MPEP 503.

New Applications Under 35 U.S.C. 111

If a new application is being filed and the application includes the necessary components for a filing date (see 37 CFR 1.53(b)-(d) and MPEP 506), a Filing Receipt (37 CFR 1.54) will be issued in due course and the date shown on this Acknowledgement Receipt will establish the filing date of the application.

National Stage of an International Application under 35 U.S.C. 371

If a timely submission to enter the national stage of an international application is compliant with the conditions of 35 U.S.C. 371 and other applicable requirements a Form PCT/DO/EO/903 indicating acceptance of the application as a national stage submission under 35 U.S.C. 371 will be issued in addition to the Filing Receipt, in due course.

New International Application Filed with the USPTO as a Receiving Office

If a new international application is being filed and the international application includes the necessary components for an international filing date (see PCT Article 11 and MPEP 1810), a Notification of the International Application Number and of the International Filing Date (Form PCT/RO/105) will be issued in due course, subject to prescriptions concerning national security, and the date shown on this Acknowledgement Receipt will establish the international filing date of the application.

RECEIVED
CENTRAL FAX CENTER
MAR 18 2013

PTO/SB/96 (07-09)
Approved for use through 07/31/2012. OMB 0651-0031
U.S. Patent and Trademark Office, U.S. DEPARTMENT OF COMMERCE

Under the Paperwork Reduction Act of 1995, no persons are required to respond to a collection of information unless it displays a valid OMB control number.

STATEMENT UNDER 37 CFR 3.73(b)

Applicant/Patent Owner: Zhou Ye, Chin-Lung Li, Shun-Nan Liou

Application No./Patent No.: 13176771 Filed/Issue Date: 07-06-2011

Titled: 3D POINTING DEVICE AND METHOD FOR COMPENSATING ROTATIONS OF THE 3D POINTING DEVICE THEREOF

CYWEE GROUP LTD., a corporation
(Name of Assignee) (Type of Assignee, e.g., corporation, partnership, university, government agency, etc.)

states that it is:

- 1. the assignee of the entire right, title, and interest in;
 - 2. an assignee of less than the entire right, title, and interest in (The extent (by percentage) of its ownership interest is _____ %); or
 - 3. the assignee of an undivided interest in the entirety of (a complete assignment from one of the joint inventors was made)
- the patent application/patent identified above, by virtue of either:

A. An assignment from the inventor(s) of the patent application/patent identified above. The assignment was recorded in the United States Patent and Trademark Office at Reel 026552, Frame 0398, or for which a copy therefore is attached.

OR

B. A chain of title from the inventor(s), of the patent application/patent identified above, to the current assignee as follows:

1. From: _____ To: _____

The document was recorded in the United States Patent and Trademark Office at Reel _____, Frame _____, or for which a copy thereof is attached.

2. From: _____ To: _____

The document was recorded in the United States Patent and Trademark Office at Reel _____, Frame _____, or for which a copy thereof is attached.

3. From: _____ To: _____

The document was recorded in the United States Patent and Trademark Office at Reel _____, Frame _____, or for which a copy thereof is attached.

Additional documents in the chain of title are listed on a supplemental sheet(s).

As required by 37 CFR 3.73(b)(1)(i), the documentary evidence of the chain of title from the original owner to the assignee was, or concurrently is being, submitted for recordation pursuant to 37 CFR 3.11.

[NOTE: A separate copy (i.e., a true copy of the original assignment document(s)) must be submitted to Assignment Division in accordance with 37 CFR Part 3, to record the assignment in the records of the USPTO. See MPEP 302.08]

The undersigned (whose title is supplied below) is authorized to act on behalf of the assignee.

[Signature]
Signature

03/18/2013
Date

Zhou Ye
Printed or Typed Name

President
Title

This collection of information is required by 37 CFR 3.73(b). The information is required to obtain or retain a benefit by the public which is to file (and by the USPTO to process) an application. Confidentiality is governed by 35 U.S.C. 122 and 37 CFR 1.11 and 1.14. This collection is estimated to take 12 minutes to complete, including gathering, preparing, and submitting the completed application form to the USPTO. Time will vary depending upon the individual case. Any comments on the amount of time you require to complete this form and/or suggestions for reducing this burden, should be sent to the Chief Information Officer, U.S. Patent and Trademark Office, U.S. Department of Commerce, P.O. Box 1450, Alexandria, VA 22313-1450. DO NOT SEND FEES OR COMPLETED FORMS TO THIS ADDRESS. SEND TO: Commissioner for Patents, P.O. Box 1450, Alexandria, VA 22313-1450.

If you need assistance in completing the form, call 1-800-PTO-9199 and select option 2.

RECEIVED
CENTRAL FAX CENTER
MAR 18 2013

PTO/AIA/82A (07-12)

Approved for use through 11/30/2014. OMB 0651-0035

U.S. Patent and Trademark Office; U.S. DEPARTMENT OF COMMERCE

Under the Paperwork Reduction Act of 1995, no persons are required to respond to a collection of information unless it displays a valid OMB control number.

TRANSMITTAL FOR POWER OF ATTORNEY TO ONE OR MORE REGISTERED PRACTITIONERS

NOTE: This form is to be submitted with the Power of Attorney by Applicant form (PTO/AIA/82B or equivalent) to identify the application to which the Power of Attorney is directed, in accordance with 37 CFR 1.5. If the Power of Attorney by Applicant form is not accompanied by this transmittal form or an equivalent, the Power of Attorney will not be recognized in the application.

Application Number	13176771
Filing Date	07-06-2011
First Named Inventor	Zhou Ye
Title	3D POINTING DEVICE AND METHOD FOR COMPENSATING ROTATIONS OF THE 3D POINTING DEVICE THEREOF
Art Unit	2692
Examiner Name	SADIO, INSA
Attorney Docket Number	040-13-0052.IUS

SIGNATURE of Applicant or Patent Practitioner

Signature	/Ding Yu Tan/	Date	03/18/2013
Name	Ding Yu Tan	Telephone	281-668-8988
Registration Number	58812		

NOTE: This form must be signed in accordance with 37 CFR 1.33. See 37 CFR 1.4(d) for signature requirements and certifications.

*Total of 1 forms are submitted.

This collection of information is required by 37 CFR 1.31, 1.32 and 1.33. The information is required to obtain or retain a benefit by the public which is to file (and by the USPTO to process) an application. Confidentiality is governed by 35 U.S.C. 122 and 37 CFR 1.11 and 1.14. This collection is estimated to take 3 minutes to complete, including gathering, preparing, and submitting the completed application form to the USPTO. Time will vary depending upon the individual case. Any comments on the amount of time you require to complete this form and/or suggestions for reducing this burden, should be sent to the Chief Information Officer, U.S. Patent and Trademark Office, U.S. Department of Commerce, P.O. Box 1450, Alexandria, VA 22313-1450. DO NOT SEND FEES OR COMPLETED FORMS TO THIS ADDRESS. SEND TO: Commissioner for Patents, P.O. Box 1450, Alexandria, VA 22313-1450.

If you need assistance in completing the form, call 1-800-PTO-9199 and select option 2.

RECEIVED
CENTRAL FAX CENTER
MAR 18 2013

PTO/AIA/828(07-12)

Approved for use through 11/30/2014. OMB 0651-0035
U.S. Patent and Trademark Office; U.S. DEPARTMENT OF COMMERCE

Under the Paperwork Reduction Act of 1995, no persons are required to respond to a collection of information unless it displays a valid OMB control number.

POWER OF ATTORNEY BY APPLICANT

I hereby revoke all previous powers of attorney given in the application identified in the attached transmittal letter.

I hereby appoint Practitioner(s) associated with the following Customer Number as my/our attorney(s) or agent(s), and to transact all business in the United States Patent and Trademark Office connected therewith for the application referenced in the attached transmittal letter (form PTO/AIA/82A or equivalent):

66749

OR

I hereby appoint Practitioner(s) named below as my/our attorney(s) or agent(s), and to transact all business in the United States Patent and Trademark Office connected therewith for the application referenced in the attached transmittal letter (form PTO/AIA/82A or equivalent):

Name	Registration Number	Name	Registration Number

Please recognize or change the correspondence address for the application identified in the attached transmittal letter to:

The address associated with the above-mentioned Customer Number.

OR

The address associated with Customer Number:

OR

Firm or Individual Name

Address

City State Zip

Country

Telephone Email

I am the Applicant:

Inventor or Joint Inventor

Legal Representative of a Deceased or Legally Incapacitated Inventor

Assignee or Person to Whom the Inventor is Under an Obligation to Assign

Person Who Otherwise Shows Sufficient Proprietary Interest (e.g., a petition under 37 CFR 1.46(b)(2) was granted in the application or is concurrently being filed with this document)

SIGNATURE of Applicant for Patent

Signature		Date	12/10/2012
Name	Zhou Ye	Telephone	281-668-8988
Title and Company	President of Cywee Group Limited		

NOTE: Signature - This form must be signed by the applicant in accordance with 37 CFR 1.33. See 37 CFR 1.4 for signature requirements and certifications. Submit multiple forms for more than one signature, see below.

*Total of 1 forms are submitted.

This collection of information is required by 37 CFR 1.31, 1.32 and 1.33. The information is required to obtain or retain a benefit by the public which is to file (and by the USPTO to process) an application. Confidentiality is governed by 35 U.S.C. 122 and 37 CFR 1.11 and 1.14. This collection is estimated to take 3 minutes to complete, including gathering, preparing, and submitting the completed application form to the USPTO. Time will vary depending upon the individual case. Any comments on the amount of time you require to complete this form and/or suggestions for reducing this burden, should be sent to the Chief Information Officer, U.S. Patent and Trademark Office, U.S. Department of Commerce, P.O. Box 1450, Alexandria, VA 22313-1450. DO NOT SEND FEES OR COMPLETED FORMS TO THIS ADDRESS. SEND TO: Commissioner for Patents, P.O. Box 1450, Alexandria, VA 22313-1450.

If you need assistance in completing the form, call 1-800-PTO-9199 and select option 2.



UNITED STATES PATENT AND TRADEMARK OFFICE

UNITED STATES DEPARTMENT OF COMMERCE
United States Patent and Trademark Office
Address: COMMISSIONER FOR PATENTS
P.O. Box 1450
Alexandria, Virginia 22313-1450
www.uspto.gov

Table with 5 columns: APPLICATION NO., FILING DATE, FIRST NAMED INVENTOR, ATTORNEY DOCKET NO., CONFIRMATION NO.
13/176,771 07/06/2011 Zhou Ye 35822-US-PA-0P-2 5154

31561 7590 01/28/2013
JIANQ CHYUN INTELLECTUAL PROPERTY OFFICE
7 FLOOR-1, NO. 100
ROOSEVELT ROAD, SECTION 2
TAIPEI, 100
TAIWAN

EXAMINER

SADIO, INSA

Table with 2 columns: ART UNIT, PAPER NUMBER

2692

Table with 2 columns: NOTIFICATION DATE, DELIVERY MODE

01/28/2013

ELECTRONIC

Please find below and/or attached an Office communication concerning this application or proceeding.

The time period for reply, if any, is set in the attached communication.

Notice of the Office communication was sent electronically on above-indicated "Notification Date" to the following e-mail address(es):

USA@JCIPGROUP.COM.TW
Belinda@JCIPGROUP.COM.TW

Office Action Summary	Application No. 13/176,771	Applicant(s) YE ET AL.	
	Examiner INSA SADIO	Art Unit 2692	

-- The MAILING DATE of this communication appears on the cover sheet with the correspondence address --

Period for Reply

A SHORTENED STATUTORY PERIOD FOR REPLY IS SET TO EXPIRE 3 MONTH(S) OR THIRTY (30) DAYS, WHICHEVER IS LONGER, FROM THE MAILING DATE OF THIS COMMUNICATION.

- Extensions of time may be available under the provisions of 37 CFR 1.136(a). In no event, however, may a reply be timely filed after SIX (6) MONTHS from the mailing date of this communication.
- If NO period for reply is specified above, the maximum statutory period will apply and will expire SIX (6) MONTHS from the mailing date of this communication.
- Failure to reply within the set or extended period for reply will, by statute, cause the application to become ABANDONED (35 U.S.C. § 133). Any reply received by the Office later than three months after the mailing date of this communication, even if timely filed, may reduce any earned patent term adjustment. See 37 CFR 1.704(b).

Status

- 1) Responsive to communication(s) filed on 06 July 2011.
- 2a) This action is **FINAL**.
- 2b) This action is non-final.
- 3) An election was made by the applicant in response to a restriction requirement set forth during the interview on _____; the restriction requirement and election have been incorporated into this action.
- 4) Since this application is in condition for allowance except for formal matters, prosecution as to the merits is closed in accordance with the practice under *Ex parte Quayle*, 1935 C.D. 11, 453 O.G. 213.

Disposition of Claims

- 5) Claim(s) 1-22 is/are pending in the application.
- 5a) Of the above claim(s) _____ is/are withdrawn from consideration.
- 6) Claim(s) _____ is/are allowed.
- 7) Claim(s) 1-22 is/are rejected.
- 8) Claim(s) _____ is/are objected to.
- 9) Claim(s) _____ are subject to restriction and/or election requirement.

* If any claims have been determined allowable, you may be eligible to benefit from the **Patent Prosecution Highway** program at a participating intellectual property office for the corresponding application. For more information, please see http://www.uspto.gov/patents/init_events/pph/index.jsp or send an inquiry to PPHfeedback@uspto.gov.

Application Papers

- 10) The specification is objected to by the Examiner.
- 11) The drawing(s) filed on 06 July 2011 is/are: a) accepted or b) objected to by the Examiner.
Applicant may not request that any objection to the drawing(s) be held in abeyance. See 37 CFR 1.85(a).
Replacement drawing sheet(s) including the correction is required if the drawing(s) is objected to. See 37 CFR 1.121(d).

Priority under 35 U.S.C. § 119

- 12) Acknowledgment is made of a claim for foreign priority under 35 U.S.C. § 119(a)-(d) or (f).
a) All b) Some * c) None of:
 - 1. Certified copies of the priority documents have been received.
 - 2. Certified copies of the priority documents have been received in Application No. _____.
 - 3. Copies of the certified copies of the priority documents have been received in this National Stage application from the International Bureau (PCT Rule 17.2(a)).

* See the attached detailed Office action for a list of the certified copies not received.

Attachment(s)

- 1) Notice of References Cited (PTO-892)
- 2) Information Disclosure Statement(s) (PTO/SB/08)
Paper No(s)/Mail Date 07/06/2011.
- 3) Interview Summary (PTO-413)
Paper No(s)/Mail Date. _____.
- 4) Other: _____.

Art Unit: 2692

DETAILED ACTION

Double Patenting

1. Claims 1-22 of this application conflict with claims 1-20 of Application No. 12/943,934. 37 CFR 1.78(b) provides that when two or more applications filed by the same applicant contain conflicting claims, elimination of such claims from all but one application may be required in the absence of good and sufficient reason for their retention during pendency in more than one application. Applicant is required to either cancel the conflicting claims from all but one application or maintain a clear line of demarcation between the applications. See MPEP § 822.

For example:

13/176,771	12/943,934
<p>1. A 3D pointing device, comprising: an orientation sensor, generating an orientation output associated with an orientation of the 3D pointing device associated with three coordinate axes of a global reference frame associated with Earth; a rotation sensor, generating a rotation output associated with a rotation of the 3D pointing device associated with three coordinate axes of a spatial reference frame associated with the 3D pointing device; and a first computing processor, using the orientation output and the rotation output to generate a transformed output associated with a fixed reference frame associated with a display device.</p>	<p>1. (original) A three-dimensional (3D) pointing device subject to movements and rotations in dynamic environments, comprising: a housing associated with said movements and rotations of the 3D pointing device in a spatial pointer reference frame; a printed circuit board (PCB) enclosed by the housing; a six-axis motion sensor module attached to the PCB, comprising a rotation sensor for detecting and generating a first signal set comprising angular velocities rex, my, coz associated with said movements and rotations of the 3D pointing device in the spatial pointer reference frame, an accelerometer for detecting and generating a second signal set comprising axial accelerations A_x, A_y, A_z associated with said movements and rotations of the 3D pointing device in the spatial pointer reference frame; and a processing and transmitting module, comprising a data transmitting unit electrically connected to the six-axis motion sensor module for transmitting said first and second signal sets thereof and a computing processor for receiving and calculating said first and second signal sets from the data transfitting unit, commnunicating with the six-axis motion sensor module to calculate a resulting deviation comprising resultant angles in said spatial pointer reference frame by utilizing a comparison to</p>

Art Unit: 2692

	<p>compare the first signal set with the second signal set whereby said resultant angles in the spatial pointer reference frame of the resulting deviation of the six-axis motion sensor module of the 3D pointing device are obtained under said dynamic environments.</p>
<p>4. The 3D pointing device of claim 3, wherein the orientation output comprises a yaw angle, a pitch angle, and a roll angle associated with the three coordinate axes of the global reference frame; the first signal set comprises a first axial acceleration, a second axial acceleration, and a third axial acceleration; the second computing processor calculates the pitch angle based on the first axial acceleration, calculates the roll angle based on the second axial acceleration and the pitch angle or based on the third axial acceleration and the pitch angle, and calculates the yaw angle based on the pitch angle, the roll angle, and the second signal set.</p>	<p>4. (original) The 3D pointing device of claim 1, wherein the spatial pointer reference frame is a reference frame in three dimensions; and wherein said resultant angles of the resulting deviation includes yaw, pitch and roll angles about each of three orthogonal coordinate axes of the spatial pointer reference frame. 5. (original) The 3D pointing device of claim 1, wherein the data transmitting unit of the processing and transmitting module is attached to the PCB enclosed by the housing and transmits said first and second signal of the six-axis motion sensor module to the computing processor via electronic connections on the PCB.</p>

Claims 2-3 and 5-22 are rejected the same based on claims 1-20 of Application No.

12/943,934.

Claim Rejections - 35 USC § 103

The following is a quotation of 35 U.S.C. 103(a) which forms the basis for all obviousness rejections set forth in this Office action:

(a) A patent may not be obtained though the invention is not identically disclosed or described as set forth in section 102 of this title, if the differences between the subject matter sought to be patented and the prior art are such that the subject matter as a whole would have been obvious at the time the invention was made to a person having ordinary skill in the art to which said subject matter pertains. Patentability shall not be negated by the manner in which the invention was made.

2.

Claims 1-22 are rejected under 35 U.S.C. 103(a) as being unpatentable over

Nasiri et al. (2009/0262074), hereinafter referenced as Nasiri.

Art Unit: 2692

As of claim 1, Nasiri discloses a controlling and accessing content using motion processing on mobile devices. Further, Nasiri teaches wherein said a 3D pointing device, comprising: an orientation sensor, generating an orientation output associated with an orientation of the 3D pointing device associated with three coordinate axes of a global reference frame ([0043], [0063], [0067], [0145], [0155], fig.2 [28]) associated with Earth (Nasiri does not specifically teach wherein said "associated with earth" but Examiner's position is that it is obvious that Nasiri referenced frame is associated with earth since it teaches on [0098] that in some embodiments a displayed map can be rotated on the display screen based on this heading in order to correctly align the displayed map with the actual directions on the surface of the Earth); a rotation sensor, generating a rotation output associated with a rotation of the 3D pointing device associated with three coordinate axes of a spatial reference frame associated with the 3D pointing device ([0043], [0063], [0067], [0114], [0115], [0145], [0155], fig.2 [28]); and a first computing processor, using the orientation output and the rotation output to generate a transformed output associated with a fixed reference frame associated with a display device ([0043], [0045], [0048], [0048], fig.2 [20 the MPU.TM]).

As of claim 2, Nasiri teaches the limitations of claim 1 above. Further, Nasiri teaches wherein said the orientation sensor comprises: an accelerometer, generating a first signal set comprising axial accelerations associated with movements and rotations of the 3D pointing device in the spatial reference frame ([0043], [0051], [0067], fig.2 [28]); and a second computing processor, generating the orientation output based on

Art Unit: 2692

the first signal set and the rotation output ([0044], [0045], [0051], [0104], [0155], [0169], fig.2 [12] please note that the processors allow motion to be detected).

As of claim 3, Nasiri teaches the limitations of claim 2 above. Further, Nasiri teaches wherein said the orientation sensor further comprises: a magnetometer, generating a second signal set associated with Earth's magnetism, wherein the second computing processor further generates the orientation output based on the first signal set, the second signal set and the rotation output or based on the first signal set and the second signal set ([0053], [0098]).

As of claim 4, Nasiri teaches the limitations of claim 3 above. Further, Nasiri teaches wherein said the orientation output comprises a yaw angle, a pitch angle, and a roll angle associated with the three coordinate axes of the global reference frame; the first signal set comprises a first axial acceleration, a second axial acceleration, and a third axial acceleration; the second computing processor calculates the pitch angle based on the first axial acceleration, calculates the roll angle based on the second axial acceleration and the pitch angle or based on the third axial acceleration and the pitch angle, and calculates the yaw angle based on the pitch angle, the roll angle, and the second signal set ([0114], [0115]).

As of claim 5, Nasiri teaches the limitations of claim 1 above. Further, Nasiri teaches wherein said the orientation output provided by the orientation sensor is a rotation matrix, a quaternion, a rotation vector, or comprises 10 three orientation angles ([0067], [0114], [0115]).

Art Unit: 2692

As of claim 6, Nasiri teaches the limitations of claim 1 above. Further, Nasiri teaches wherein said the transformed output represents a segment of a movement in a plane in the fixed reference frame parallel to a screen of the display device ([0178]).

As of claim 7, Nasiri teaches the limitations of claim 1 above. Further, Nasiri teaches wherein said the first computing processor 15 obtains an orientation of the display device associated with the global reference frame, obtains an orientation of the 3D pointing device associated with the fixed reference frame based on the orientation output and the orientation of the display device associated with the global reference frame, generates a transformed rotation associated with the fixed reference frame based on the orientation of the 3D pointing device associated with the fixed reference frame and the rotation output, and generates the transformed output based on the transformed rotation ([0043], [0044], [0045], [0048], [0051], [0104], [0155], [0169], fig.2 [20 the MPU.TM], fig.2 [12]).

As of claim 8, Nasiri teaches the limitations of claim 7 above. Further, Nasiri teaches wherein said when the first computing processor receives a reset signal, the first computing processor records a current orientation output generated by the orientation sensor as the orientation of the display device associated with the global reference frame ([0051], [0155], please note that the controller would do the same as sending a reset signal to the computing processor).

As of claim 9, Nasiri teaches the limitations of claim 8 above. Further, Nasiri teaches wherein said the current orientation output comprises a yaw angle associated with one of the three coordinate axes of the global reference frame, the first computing

Art Unit: 2692

processor obtains the orientation of the 3D pointing device associated with the fixed reference frame by subtracting the yaw angle from the orientation output ([0067], [0114], [0115], please note that calculating the resulting deviation angles may involve subtraction).

As of claim 10, Nasiri teaches the limitations of claim 7 above. Further, Nasiri teaches wherein said the first computing processor obtains a rotation matrix from the orientation of the 3D pointing device associated with the fixed reference frame, and multiplies the rotation matrix and the rotation output together to generate the transformed rotation ([0067], [0114], [0115], please note that calculating the resulting deviation angles may involve multiplication).

. **As of claim 11**, Nasiri teaches the limitations of claim 10 above. Further, Nasiri teaches wherein said the transformed rotation comprises a first angular velocity, a second angular velocity, and a third angular velocity associated with three coordinate axes of the fixed reference frame ([0049], [0067], [0114], [0115]); the transformed output comprises a first movement component and a second movement component associated with two of the three coordinate axes of the fixed reference frame ([0115]); the first computing processor multiplies the second angular velocity by a scale factor to generate the second movement component and multiplies the third angular velocity by the scale factor to generate the first movement component ([0067], [0114], [0115], please note that calculating the resulting deviation angles may involve multiplication).

As of claims 12-22, claims 12-22 are rejected the same as respectively claims 1-11. Only claims 12-22 are method claims.

Art Unit: 2692

Conclusion

3. Any inquiry concerning this communication or earlier communications from the examiner should be directed to INSA SADIO whose telephone number is (571)270-5580. The examiner can normally be reached on MONDAY through FRIDAY 8am to 5pm.

If attempts to reach the examiner by telephone are unsuccessful, the examiner's supervisor, LunYi Lao can be reached on 571-272-7671. The fax phone number for the organization where this application or proceeding is assigned is 571-273-8300.

Information regarding the status of an application may be obtained from the Patent Application Information Retrieval (PAIR) system. Status information for published applications may be obtained from either Private PAIR or Public PAIR. Status information for unpublished applications is available through Private PAIR only. For more information about the PAIR system, see <http://pair-direct.uspto.gov>. Should you have questions on access to the Private PAIR system, contact the Electronic Business Center (EBC) at 866-217-9197 (toll-free). If you would like assistance from a USPTO Customer Service Representative or access to the automated information system, call 800-786-9199 (IN USA OR CANADA) or 571-272-1000.

INSA SADIO
Examiner
Art Unit 2692

/INSA SADIO/
Examiner, Art Unit 2692

Application/Control Number: 13/176,771

Page 9

Art Unit: 2692

/LUN-YI LAO/

Supervisory Patent Examiner, Art Unit 2692

Notice of References Cited	Application/Control No. 13/176,771	Applicant(s)/Patent Under Reexamination YE ET AL.	
	Examiner INSA SADIO	Art Unit 2692	Page 1 of 1

U.S. PATENT DOCUMENTS

*	Document Number Country Code-Number-Kind Code	Date MM-YYYY	Name	Classification
*	A US-2009/0262074 A1	10-2009	NASIRI et al.	345/158
B	US-			
C	US-			
D	US-			
E	US-			
F	US-			
G	US-			
H	US-			
I	US-			
J	US-			
K	US-			
L	US-			
M	US-			

FOREIGN PATENT DOCUMENTS

*	Document Number Country Code-Number-Kind Code	Date MM-YYYY	Country	Name	Classification
N					
O					
P					
Q					
R					
S					
T					

NON-PATENT DOCUMENTS

*	Document Number Country Code-Number-Kind Code	Date MM-YYYY	Country	Name	Classification
*	Include as applicable: Author, Title Date, Publisher, Edition or Volume, Pertinent Pages)				
U					
V					
W					
X					

*A copy of this reference is not being furnished with this Office action. (See MPEP § 707.05(a).)
Dates in MM-YYYY format are publication dates. Classifications may be US or foreign.

Search Notes 	Application/Control No. 13176771	Applicant(s)/Patent Under Reexamination YE ET AL.
	Examiner INSA SADIO	Art Unit 2692

SEARCHED			
Class	Subclass	Date	Examiner
345	156-168	12/31/2012	/IS/

SEARCH NOTES		
Search Notes	Date	Examiner
Inventor search	12/31/2012	/IS/

INTERFERENCE SEARCH			
Class	Subclass	Date	Examiner

--	--

Receipt date: 07/06/2011

13176771 - GAI: 2692

Doc code: IDS

Pat. Sec. 101-10

Doc description: Information Disclosure Statement (IDS) Filed

Approved for use through 07/31/2012. OMB 0651-0031
U.S. Patent and Trademark Office; U.S. DEPARTMENT OF COMMERCE

Under the Paperwork Reduction Act of 1995, no persons are required to respond to a collection of information unless it contains a valid OMB control number.

INFORMATION DISCLOSURE STATEMENT BY APPLICANT (Not for submission under 37 CFR 1.99)	Application Number		
	Filing Date		
	First Named Inventor	Zhou Ye	
	Art Unit		
	Examiner Name		
	Attorney Docket Number	35822-US-PA-0P-2	

U.S. PATENTS						Remove
Examiner Initial*	Cite No	Patent Number	Kind Code ¹	Issue Date	Name of Patentee or Applicant of cited Document	Pages, Columns, Lines where Relevant Passages or Relevant Figures Appear
	1	5138154		1992-08-11	Hotelling	
	2	5440326		1995-08-08	Quinn	
	3	5898421		1999-04-27	Quinn	
	4	7158118		2007-01-02	Liberty	
	5	7236156		2007-06-26	Liberty , et al.	
	6	7239301		2007-07-03	Liberty , et al.	
	7	7262760		2007-08-28	Liberty	
	8	7414611		2008-08-19	Liberty	

INFORMATION DISCLOSURE STATEMENT BY APPLICANT (Not for submission under 37 CFR 1.99)	Application Number		13176771 - GAU: 2692	
	Filing Date			
	First Named Inventor	Zhou Ye		
	Art Unit			
	Examiner Name			
	Attorney Docket Number		35822-US-PA-0P-2	

	9	7489298		2009-02-10	Liberty , et al.	
	10	7535456		2009-05-19	Liberty , et al.	

If you wish to add additional U.S. Patent citation information please click the Add button. Add

U.S.PATENT APPLICATION PUBLICATIONS Remove

Examiner Initial*	Cite No	Publication Number	Kind Code ¹	Publication Date	Name of Patentee or Applicant of cited Document	Pages,Columns,Lines where Relevant Passages or Relevant Figures Appear
	1					

If you wish to add additional U.S. Published Application citation information please click the Add button. Add

FOREIGN PATENT DOCUMENTS Remove

Examiner Initial*	Cite No	Foreign Document Number ³	Country Code ² j	Kind Code ⁴	Publication Date	Name of Patentee or Applicant of cited Document	Pages,Columns,Lines where Relevant Passages or Relevant Figures Appear	T ⁵
	1							<input type="checkbox"/>

If you wish to add additional Foreign Patent Document citation information please click the Add button Add

NON-PATENT LITERATURE DOCUMENTS Remove

Examiner Initials*	Cite No	Include name of the author (in CAPITAL LETTERS), title of the article (when appropriate), title of the item (book, magazine, journal, serial, symposium, catalog, etc), date, pages(s), volume-issue number(s), publisher, city and/or country where published.	T ⁵
	1		<input type="checkbox"/>

If you wish to add additional non-patent literature document citation information please click the Add button Add

INFORMATION DISCLOSURE STATEMENT BY APPLICANT (Not for submission under 37 CFR 1.99)	Application Number		13176771 - GAU: 2692	
	Filing Date			
	First Named Inventor	Zhou Ye		
	Art Unit			
	Examiner Name			
	Attorney Docket Number		35822-US-PA-0P-2	

EXAMINER SIGNATURE			
Examiner Signature	/Insa Sadio/ (12/31/2012)	Date Considered	12/31/2012

*EXAMINER: Initial if reference considered, whether or not citation is in conformance with MPEP 609. Draw line through a citation if not in conformance and not considered. Include copy of this form with next communication to applicant.

¹ See Kind Codes of USPTO Patent Documents at www.USPTO.GOV or MPEP 901.04. ² Enter office that issued the document, by the two-letter code (WIPO Standard ST.3). ³ For Japanese patent documents, the indication of the year of the reign of the Emperor must precede the serial number of the patent document. ⁴ Kind of document by the appropriate symbols as indicated on the document under WIPO Standard ST.16 if possible. ⁵ Applicant is to place a check mark here if English language translation is attached.

EAST Search History

EAST Search History (Prior Art)

Ref #	Hits	Search Query	DBs	Default Operator	Plurals	Time Stamp
S1	76	((ZHOU) near2 (YE)).INV.	US-PGPUB; USPAT	OR	OFF	2012/12/29 20:11
S2	6	((CHIN-LUNG) near2 (LI)).INV.	US-PGPUB; USPAT	OR	OFF	2012/12/29 20:12
S3	52	((SHUN-NAN) near2 (LIOU)).INV.	US-PGPUB; USPAT	OR	OFF	2012/12/29 20:12
S4	118	S1 S2 S3	US-PGPUB; USPAT; USOCR; FPRS; EPO; JPO; DERWENT; IBM_TDB	OR	ON	2012/12/29 20:15
S5	39	("5440326" "7236156" "6061611" "7158118" "7414611" "7489298" "7535456" "5898421" "7262760" "7817134" "5138154" "7239301" "20110307173" "7774155" "7924264" "20080096654" "6993451" "8010313" "20090262074").PN.	US-PGPUB; USPAT; USOCR; FPRS; EPO; JPO; DERWENT; IBM_TDB	OR	ON	2012/12/29 20:16
S6	10	US-6993451-\$.DID. OR US-7774155- \$.DID. OR US-8010313-\$.DID. OR US- 20080096654-\$.DID. OR US-6061611- \$.DID. OR US-7924264-\$.DID. OR US- 7817134-\$.DID. OR US-20090262074- \$.DID. OR US-1994197-\$.DID.	US-PGPUB; USPAT; USOCR	OR	OFF	2012/12/29 20:17
S7	10	US-5138154-\$.DID. OR US-5440326- \$.DID. OR US-5898421-\$.DID. OR US- 7158118-\$.DID. OR US-7236156-\$.DID. OR US-7239301-\$.DID. OR US- 7262760-\$.DID. OR US-7414611-\$.DID. OR US-7489298-\$.DID. OR US- 7535456-\$.DID.	US-PGPUB; USPAT; USOCR	OR	OFF	2012/12/29 20:18
S8	41	S5 S6 S7	US-PGPUB; USPAT; USOCR; FPRS; EPO; JPO; DERWENT; IBM_TDB	OR	ON	2012/12/29 20:18
S9	7	US-6993451-\$.DID. OR US-7774155- \$.DID. OR US-8010313-\$.DID. OR US- 20080096654-\$.DID. OR US-6061611- \$.DID. OR US-7924264-\$.DID. OR US- 7817134-\$.DID.	US-PGPUB; USPAT; USOCR	OR	OFF	2012/12/29 20:19
S10	41	S8 S9	US-PGPUB; USPAT; USOCR; FPRS; EPO;	OR	ON	2012/12/29 20:19

			JPO; DERWENT; IBM_TDB			
S11	21	("5440326" "7489298" "5138154" "7262760" "7158118" "7414611" "5440326" "5898421" "5898421" "7236156" "7262760" "7239301" "7239301" "7489298" "7535456" "5138154" "7158118" "7236156" "7535456" "7414611").PN.	US-PGPUB; USPAT; USOCR; FPRS; EPO; JPO; DERWENT; IBM_TDB	OR	ON	2012/12/29 20:19
S12	41	S5 S6 S8 S9 S10 S11	US-PGPUB; USPAT; USOCR; FPRS; EPO; JPO; DERWENT; IBM_TDB	OR	ON	2012/12/29 20:20
S13	3	12/943934	US-PGPUB; USPAT; USOCR; FPRS; EPO; JPO; DERWENT; IBM_TDB	OR	ON	2012/12/29 20:21
S14	18848	345/156-168.ccls.	US-PGPUB; USPAT; USOCR; FPRS; EPO; JPO; DERWENT; IBM_TDB	OR	ON	2012/12/29 20:21
S15	14	S12 and S14	US-PGPUB; USPAT; USOCR; FPRS; EPO; JPO; DERWENT; IBM_TDB	OR	ON	2012/12/29 20:22
S16	10	S15 and (orient\$3 with sens\$3)	US-PGPUB; USPAT; USOCR; FPRS; EPO; JPO; DERWENT; IBM_TDB	OR	ON	2012/12/29 20:37
S17	11	S15 and (orient\$3 same sens\$3)	US-PGPUB; USPAT; USOCR; FPRS; EPO; JPO; DERWENT; IBM_TDB	OR	ON	2012/12/29 20:37
S18	13	S15 and (orientat\$3 same sens\$3)	US-PGPUB; USPAT; USOCR; FPRS; EPO; JPO; DERWENT; IBM_TDB	OR	ON	2012/12/29 20:39
S19	13	S15 and (orientat\$3 same sens\$3) and (rotat\$3 same sens\$3)	US-PGPUB; USPAT;	OR	ON	2012/12/29 20:41

			USOCR; FPRS; EPO; JPO; DERWENT; IBM_TDB			
S20	11	S15 and (orientat\$3 same sens\$3) and (rotat\$3 same sens\$3)and (comput\$3 with process\$4)	US-PGPUB; USPAT; USOCR; FPRS; EPO; JPO; DERWENT; IBM_TDB	OR	ON	2012/12/29 20:44
S21	0	"20090262074".pn. and (earth same (magnet\$5 magnetometer))	US-PGPUB; USPAT; USOCR; FPRS; EPO; JPO; DERWENT; IBM_TDB	OR	ON	2012/12/29 23:32
S22	0	"20090262074".pn. and (earth same (magnetism magnet\$3 magnetometer))	US-PGPUB; USPAT; USOCR; FPRS; EPO; JPO; DERWENT; IBM_TDB	OR	ON	2012/12/29 23:33
S23	1	"20090262074".pn. and (earth and (magnetism magnet\$3 magnetometer))	US-PGPUB; USPAT; USOCR; FPRS; EPO; JPO; DERWENT; IBM_TDB	OR	ON	2012/12/29 23:34
S24	1	"20090262074".pn. and (earth and (magnetism magnet\$3 magnetometer orbit\$4))	US-PGPUB; USPAT; USOCR; FPRS; EPO; JPO; DERWENT; IBM_TDB	OR	ON	2012/12/29 23:35
S25	1	"20090262074".pn. and (earth and (magnetism magnet\$3 magnetometer orbit\$4 orientat\$3))	US-PGPUB; USPAT; USOCR; FPRS; EPO; JPO; DERWENT; IBM_TDB	OR	ON	2012/12/29 23:36
S26	1	"20090262074".pn. and (earth and (magnetism magnet\$3 magnetometer orbit\$4 orientat\$3 space))	US-PGPUB; USPAT; USOCR; FPRS; EPO; JPO; DERWENT; IBM_TDB	OR	ON	2012/12/29 23:38
S27	1	"20090262074".pn. and (control\$4 with process\$3)	US-PGPUB; USPAT; USOCR; FPRS; EPO; JPO; DERWENT; IBM_TDB	OR	ON	2012/12/29 23:58

S28	1	"20090262074".pn. and (control\$4 with process\$3) and (velocit\$3 and movement)	US-PGPUB; USPAT; USOCR; FPRS; EPO; JPO; DERWENT; IBM_TDB	OR	ON	2012/12/30 00:17
S29	1	"20090262074".pn. and (control\$4 with process\$3) and (velocit\$3 same movement)	US-PGPUB; USPAT; USOCR; FPRS; EPO; JPO; DERWENT; IBM_TDB	OR	ON	2012/12/30 00:17
S30	1	"20090262074".pn. and (control\$4 with process\$3) and (velocit\$3 with movement)	US-PGPUB; USPAT; USOCR; FPRS; EPO; JPO; DERWENT; IBM_TDB	OR	ON	2012/12/30 00:17

EAST Search History (Interference)

<This search history is empty>

12/ 31/ 2012 11:44:07 AM**C:\Users\isadio\Documents\EAST\Workspaces\13176771.wsp**



UNITED STATES PATENT AND TRADEMARK OFFICE

UNITED STATES DEPARTMENT OF COMMERCE
 United States Patent and Trademark Office
 Address: COMMISSIONER FOR PATENTS
 P.O. Box 1450
 Alexandria, Virginia 22313-1450
 www.uspto.gov

BIB DATA SHEET

CONFIRMATION NO. 5154

SERIAL NUMBER 13/176,771	FILING or 371(c) DATE 07/06/2011 RULE	CLASS 345	GROUP ART UNIT 2692	ATTORNEY DOCKET NO. 35822-US-PA-0P-2	
APPLICANTS Zhou Ye, Foster City, CA; Chin-Lung Li, Taoyuan County, TAIWAN; Shun-Nan Liou, Kaohsiung City, TAIWAN; ** CONTINUING DATA ***** This application is a CIP of 13/072,794 03/28/2011 which is a CIP of 12/943,934 11/11/2010 which claims benefit of 61/292,558 01/06/2010 ** FOREIGN APPLICATIONS ***** ** IF REQUIRED, FOREIGN FILING LICENSE GRANTED *** SMALL ENTITY ** 07/15/2011					
Foreign Priority claimed <input type="checkbox"/> Yes <input checked="" type="checkbox"/> No 35 USC 119(a-d) conditions met <input type="checkbox"/> Yes <input checked="" type="checkbox"/> No Verified and Acknowledged <u>/INSA SADIO/</u> Examiner's Signature	<input type="checkbox"/> Met after Allowance Initials	STATE OR COUNTRY CA	SHEETS DRAWINGS 12	TOTAL CLAIMS 22	INDEPENDENT CLAIMS 2
ADDRESS JIANQ CHYUN INTELLECTUAL PROPERTY OFFICE 7 FLOOR-1, NO. 100 ROOSEVELT ROAD, SECTION 2 TAIPEI, 100 TAIWAN					
TITLE 3D POINTING DEVICE AND METHOD FOR COMPENSATING ROTATIONS OF THE 3D POINTING DEVICE THEREOF					
FILING FEE RECEIVED 514	FEES: Authority has been given in Paper No. _____ to charge/credit DEPOSIT ACCOUNT No. _____ for following:		<input type="checkbox"/> All Fees <input type="checkbox"/> 1.16 Fees (Filing) <input type="checkbox"/> 1.17 Fees (Processing Ext. of time) <input type="checkbox"/> 1.18 Fees (Issue) <input type="checkbox"/> Other _____ <input type="checkbox"/> Credit		



UNITED STATES PATENT AND TRADEMARK OFFICE

UNITED STATES DEPARTMENT OF COMMERCE
United States Patent and Trademark Office
Address: COMMISSIONER FOR PATENTS
P.O. Box 1450
Alexandria, Virginia 22313-1450
www.uspto.gov

Table with 4 columns: APPLICATION NUMBER (13/176,771), FILING OR 371(C) DATE (07/06/2011), FIRST NAMED APPLICANT (Zhou Ye), ATTY. DOCKET NO./TITLE (35822-US-PA-0P-2)

CONFIRMATION NO. 5154

PUBLICATION NOTICE



31561
JIANQ CHYUN INTELLECTUAL PROPERTY OFFICE
7 FLOOR-1, NO. 100
ROOSEVELT ROAD, SECTION 2
TAIPEI, 100
TAIWAN

Title:3D POINTING DEVICE AND METHOD FOR COMPENSATING ROTATIONS OF THE 3D POINTING DEVICE THEREOF

Publication No.US-2011-0260968-A1

Publication Date:10/27/2011

NOTICE OF PUBLICATION OF APPLICATION

The above-identified application will be electronically published as a patent application publication pursuant to 37 CFR 1.211, et seq. The patent application publication number and publication date are set forth above.

The publication may be accessed through the USPTO's publically available Searchable Databases via the Internet at www.uspto.gov. The direct link to access the publication is currently http://www.uspto.gov/patft/.

The publication process established by the Office does not provide for mailing a copy of the publication to applicant. A copy of the publication may be obtained from the Office upon payment of the appropriate fee set forth in 37 CFR 1.19(a)(1). Orders for copies of patent application publications are handled by the USPTO's Office of Public Records. The Office of Public Records can be reached by telephone at (703) 308-9726 or (800) 972-6382, by facsimile at (703) 305-8759, by mail addressed to the United States Patent and Trademark Office, Office of Public Records, Alexandria, VA 22313-1450 or via the Internet.

In addition, information on the status of the application, including the mailing date of Office actions and the dates of receipt of correspondence filed in the Office, may also be accessed via the Internet through the Patent Electronic Business Center at www.uspto.gov using the public side of the Patent Application Information and Retrieval (PAIR) system. The direct link to access this status information is currently http://pair.uspto.gov/. Prior to publication, such status information is confidential and may only be obtained by applicant using the private side of PAIR.

Further assistance in electronically accessing the publication, or about PAIR, is available by calling the Patent Electronic Business Center at 1-866-217-9197.

Office of Data Management, Application Assistance Unit (571) 272-4000, or (571) 272-4200, or 1-888-786-0101

PATENT APPLICATION FEE DETERMINATION RECORD

Substitute for Form PTO-875

Application or Docket Number
13/176,771

APPLICATION AS FILED - PART I

(Column 1) (Column 2)

FOR	NUMBER FILED	NUMBER EXTRA
BASIC FEE (37 CFR 1.16(a), (b), or (c))	N/A	N/A
SEARCH FEE (37 CFR 1.16(k), (l), or (m))	N/A	N/A
EXAMINATION FEE (37 CFR 1.16(o), (p), or (q))	N/A	N/A
TOTAL CLAIMS (37 CFR 1.16(j))	22 minus 20 = *	2
INDEPENDENT CLAIMS (37 CFR 1.16(h))	2 minus 3 = *	
APPLICATION SIZE FEE (37 CFR 1.16(s))	If the specification and drawings exceed 100 sheets of paper, the application size fee due is \$270 (\$135 for small entity) for each additional 50 sheets or fraction thereof. See 35 U.S.C. 41(a)(1)(G) and 37 CFR 1.16(s).	
MULTIPLE DEPENDENT CLAIM PRESENT (37 CFR 1.16(j))		

* If the difference in column 1 is less than zero, enter "0" in column 2.

SMALL ENTITY

RATE(\$)	FEE(\$)
N/A	82
N/A	270
N/A	110
x 26 =	52
x 110 =	0.00
	0.00
TOTAL	514

OR OTHER THAN SMALL ENTITY

RATE(\$)	FEE(\$)
N/A	
N/A	
N/A	
TOTAL	

APPLICATION AS AMENDED - PART II

(Column 1) (Column 2) (Column 3)

AMENDMENT A	CLAIMS REMAINING AFTER AMENDMENT		HIGHEST NUMBER PREVIOUSLY PAID FOR	PRESENT EXTRA
	Total (37 CFR 1.16(i))	*	Minus	**
Independent (37 CFR 1.16(h))	*	Minus	***	=
Application Size Fee (37 CFR 1.16(s))				
FIRST PRESENTATION OF MULTIPLE DEPENDENT CLAIM (37 CFR 1.16(j))				

SMALL ENTITY

RATE(\$)	ADDITIONAL FEE(\$)
x =	
x =	
TOTAL ADD'L FEE	

OR OTHER THAN SMALL ENTITY

RATE(\$)	ADDITIONAL FEE(\$)
x =	
x =	
TOTAL ADD'L FEE	

(Column 1) (Column 2) (Column 3)

AMENDMENT B	CLAIMS REMAINING AFTER AMENDMENT		HIGHEST NUMBER PREVIOUSLY PAID FOR	PRESENT EXTRA
	Total (37 CFR 1.16(i))	*	Minus	**
Independent (37 CFR 1.16(h))	*	Minus	***	=
Application Size Fee (37 CFR 1.16(s))				
FIRST PRESENTATION OF MULTIPLE DEPENDENT CLAIM (37 CFR 1.16(j))				

RATE(\$)	ADDITIONAL FEE(\$)
x =	
x =	
TOTAL ADD'L FEE	

OR OTHER THAN SMALL ENTITY

RATE(\$)	ADDITIONAL FEE(\$)
x =	
x =	
TOTAL ADD'L FEE	

* If the entry in column 1 is less than the entry in column 2, write "0" in column 3.
 ** If the "Highest Number Previously Paid For" IN THIS SPACE is less than 20, enter "20".
 *** If the "Highest Number Previously Paid For" IN THIS SPACE is less than 3, enter "3".
 The "Highest Number Previously Paid For" (Total or Independent) is the highest found in the appropriate box in column 1.



UNITED STATES PATENT AND TRADEMARK OFFICE

UNITED STATES DEPARTMENT OF COMMERCE
United States Patent and Trademark Office
Address: COMMISSIONER FOR PATENTS
P.O. Box 1450
Alexandria, Virginia 22313-1450
www.uspto.gov

Table with 7 columns: APPLICATION NUMBER, FILING or 371(c) DATE, GRP ART UNIT, FIL FEE REC'D, ATTY. DOCKET NO, TOT CLAIMS, IND CLAIMS. Row 1: 13/176,771, 07/06/2011, 2629, 514, 35822-US-PA-0P-2, 22, 2

CONFIRMATION NO. 5154

FILING RECEIPT



31561
JIANQ CHYUN INTELLECTUAL PROPERTY OFFICE
7 FLOOR-1, NO. 100
ROOSEVELT ROAD, SECTION 2
TAIPEI, 100
TAIWAN

Date Mailed: 07/22/2011

Receipt is acknowledged of this non-provisional patent application. The application will be taken up for examination in due course. Applicant will be notified as to the results of the examination. Any correspondence concerning the application must include the following identification information: the U.S. APPLICATION NUMBER, FILING DATE, NAME OF APPLICANT, and TITLE OF INVENTION. Fees transmitted by check or draft are subject to collection. Please verify the accuracy of the data presented on this receipt. If an error is noted on this Filing Receipt, please submit a written request for a Filing Receipt Correction. Please provide a copy of this Filing Receipt with the changes noted thereon. If you received a "Notice to File Missing Parts" for this application, please submit any corrections to this Filing Receipt with your reply to the Notice. When the USPTO processes the reply to the Notice, the USPTO will generate another Filing Receipt incorporating the requested corrections

Applicant(s)

Zhou Ye, Foster City, CA;
Chin-Lung Li, Taoyuan County, TAIWAN;
Shun-Nan Liou, Kaohsiung City, TAIWAN;

Assignment For Published Patent Application

CYWEE GROUP LTD., Taipei City, TAIWAN

Power of Attorney: The patent practitioners associated with Customer Number 31561

Domestic Priority data as claimed by applicant

This application is a CIP of 13/072,794 03/28/2011
which is a CIP of 12/943,934 11/11/2010
which claims benefit of 61/292,558 01/06/2010

Foreign Applications (You may be eligible to benefit from the Patent Prosecution Highway program at the USPTO. Please see http://www.uspto.gov for more information.)

If Required, Foreign Filing License Granted: 07/15/2011

The country code and number of your priority application, to be used for filing abroad under the Paris Convention, is US 13/176,771

Projected Publication Date: 10/27/2011

Non-Publication Request: No

Early Publication Request: No

** SMALL ENTITY **

Title

3D POINTING DEVICE AND METHOD FOR COMPENSATING ROTATIONS OF THE 3D POINTING DEVICE THEREOF

Preliminary Class

345

PROTECTING YOUR INVENTION OUTSIDE THE UNITED STATES

Since the rights granted by a U.S. patent extend only throughout the territory of the United States and have no effect in a foreign country, an inventor who wishes patent protection in another country must apply for a patent in a specific country or in regional patent offices. Applicants may wish to consider the filing of an international application under the Patent Cooperation Treaty (PCT). An international (PCT) application generally has the same effect as a regular national patent application in each PCT-member country. The PCT process **simplifies** the filing of patent applications on the same invention in member countries, but **does not result** in a grant of "an international patent" and does not eliminate the need of applicants to file additional documents and fees in countries where patent protection is desired.

Almost every country has its own patent law, and a person desiring a patent in a particular country must make an application for patent in that country in accordance with its particular laws. Since the laws of many countries differ in various respects from the patent law of the United States, applicants are advised to seek guidance from specific foreign countries to ensure that patent rights are not lost prematurely.

Applicants also are advised that in the case of inventions made in the United States, the Director of the USPTO must issue a license before applicants can apply for a patent in a foreign country. The filing of a U.S. patent application serves as a request for a foreign filing license. The application's filing receipt contains further information and guidance as to the status of applicant's license for foreign filing.

Applicants may wish to consult the USPTO booklet, "General Information Concerning Patents" (specifically, the section entitled "Treaties and Foreign Patents") for more information on timeframes and deadlines for filing foreign patent applications. The guide is available either by contacting the USPTO Contact Center at 800-786-9199, or it can be viewed on the USPTO website at <http://www.uspto.gov/web/offices/pac/doc/general/index.html>.

For information on preventing theft of your intellectual property (patents, trademarks and copyrights), you may wish to consult the U.S. Government website, <http://www.stopfakes.gov>. Part of a Department of Commerce initiative, this website includes self-help "toolkits" giving innovators guidance on how to protect intellectual property in specific countries such as China, Korea and Mexico. For questions regarding patent enforcement issues, applicants may call the U.S. Government hotline at 1-866-999-HALT (1-866-999-4158).

LICENSE FOR FOREIGN FILING UNDER**Title 35, United States Code, Section 184****Title 37, Code of Federal Regulations, 5.11 & 5.15****GRANTED**

The applicant has been granted a license under 35 U.S.C. 184, if the phrase "IF REQUIRED, FOREIGN FILING LICENSE GRANTED" followed by a date appears on this form. Such licenses are issued in all applications where

the conditions for issuance of a license have been met, regardless of whether or not a license may be required as set forth in 37 CFR 5.15. The scope and limitations of this license are set forth in 37 CFR 5.15(a) unless an earlier license has been issued under 37 CFR 5.15(b). The license is subject to revocation upon written notification. The date indicated is the effective date of the license, unless an earlier license of similar scope has been granted under 37 CFR 5.13 or 5.14.

This license is to be retained by the licensee and may be used at any time on or after the effective date thereof unless it is revoked. This license is automatically transferred to any related applications(s) filed under 37 CFR 1.53(d). This license is not retroactive.

The grant of a license does not in any way lessen the responsibility of a licensee for the security of the subject matter as imposed by any Government contract or the provisions of existing laws relating to espionage and the national security or the export of technical data. Licensees should apprise themselves of current regulations especially with respect to certain countries, of other agencies, particularly the Office of Defense Trade Controls, Department of State (with respect to Arms, Munitions and Implements of War (22 CFR 121-128)); the Bureau of Industry and Security, Department of Commerce (15 CFR parts 730-774); the Office of Foreign Assets Control, Department of Treasury (31 CFR Parts 500+) and the Department of Energy.

NOT GRANTED

No license under 35 U.S.C. 184 has been granted at this time, if the phrase "IF REQUIRED, FOREIGN FILING LICENSE GRANTED" DOES NOT appear on this form. Applicant may still petition for a license under 37 CFR 5.12, if a license is desired before the expiration of 6 months from the filing date of the application. If 6 months has lapsed from the filing date of this application and the licensee has not received any indication of a secrecy order under 35 U.S.C. 181, the licensee may foreign file the application pursuant to 37 CFR 5.15(b).



UNITED STATES PATENT AND TRADEMARK OFFICE

UNITED STATES DEPARTMENT OF COMMERCE
United States Patent and Trademark Office
Address: COMMISSIONER FOR PATENTS
P.O. Box 1450
Alexandria, Virginia 22313-1450
www.uspto.gov

APPLICATION NUMBER	FILING OR 371(C) DATE	FIRST NAMED APPLICANT	ATTY. DOCKET NO./TITLE
13/176,771	07/06/2011	Zhou Ye	35822-US-PA-0P-2

CONFIRMATION NO. 5154

POA ACCEPTANCE LETTER



31561
JIANQ CHYUN INTELLECTUAL PROPERTY OFFICE
7 FLOOR-1, NO. 100
ROOSEVELT ROAD, SECTION 2
TAIPEI, 100
TAIWAN

Date Mailed: 07/22/2011

NOTICE OF ACCEPTANCE OF POWER OF ATTORNEY

This is in response to the Power of Attorney filed 07/06/2011.

The Power of Attorney in this application is accepted. Correspondence in this application will be mailed to the above address as provided by 37 CFR 1.33.

/tmekuria/

Office of Data Management, Application Assistance Unit (571) 272-4000, or (571) 272-4200, or 1-888-786-0101

POWER OF ATTORNEY

AND

CORRESPONDENCE ADDRESS INDICATION FORM

First Names Inventor	: Zhou Ye		
Title	: 3D POINTING DEVICE AND METHOD FOR COMPENSATING ROTATIONS OF THE 3D POINTING DEVICE THEREOF		
Attorney Docket Number	: 35822-US-PA-0P-2		
Application Number	:	Filing Date	:
Art Unit	:	Examiner Name	:

As the below named inventor(s), I hereby appoint : practitioners associated with the Customer Number : **31561**

as my/our attorney(s) or patent agent(s) to prosecute the application identified above, and to transact business in the United States Patent and Trademark Office connected therewith.

Please recognize the correspondence address for the above-identified application to : the address associated with the above-mentioned Customer Number.

SIGNATURE(s) of Applicant/Inventor

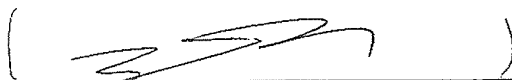
Signature: ()

Sole or First Joint Inventor: Zhou Ye

Date: July. 5, 2011

Signature: 

Second Joint Inventor (if any): Chin-Lung Li

Date: 2011. 7. 5

201011-D-US
35822-US-PA-0P-2

POWER OF ATTORNEY
AND
CORRESPONDENCE ADDRESS INDICATION FORM

SIGNATURE(s) of Applicant/Inventor

Signature: Shun-Nan Liou Date: 2011. 7. 5
Third Joint Inventor (if any): Shun-Nan Liou

Under the Paperwork Reduction Act of 1995, no persons are required to respond to a collection of information unless it contains a valid OMB control number.

Application Data Sheet 37 CFR 1.76		Attorney Docket Number	35822-US-PA-0P-2
		Application Number	
Title of Invention	3D POINTING DEVICE AND METHOD FOR COMPENSATING ROTATIONS OF THE 3D POINTING DEVICE THEREOF		
The application data sheet is part of the provisional or nonprovisional application for which it is being submitted. The following form contains the bibliographic data arranged in a format specified by the United States Patent and Trademark Office as outlined in 37 CFR 1.76. This document may be completed electronically and submitted to the Office in electronic format using the Electronic Filing System (EFS) or the document may be printed and included in a paper filed application.			

Secrecy Order 37 CFR 5.2

Portions or all of the application associated with this Application Data Sheet may fall under a Secrecy Order pursuant to 37 CFR 5.2 (Paper filers only. Applications that fall under Secrecy Order may not be filed electronically.)

Applicant Information:

Applicant 1					Remove
Applicant Authority <input checked="" type="radio"/> Inventor		<input type="radio"/> Legal Representative under 35 U.S.C. 117		<input type="radio"/> Party of Interest under 35 U.S.C. 118	
Prefix	Given Name	Middle Name	Family Name	Suffix	
	Zhou		Ye		
Residence Information (Select One) <input checked="" type="radio"/> US Residency <input type="radio"/> Non US Residency <input type="radio"/> Active US Military Service					
City	Foster City	State/Province	CA	Country of Residenceⁱ	US
Citizenship under 37 CFR 1.41(b)ⁱ		CN			
Mailing Address of Applicant:					
Address 1	542 Hanbury Lane,				
Address 2					
City	Foster City	State/Province	CA		
Postal Code	94404	Countryⁱ	US		
Applicant 2					Remove
Applicant Authority <input checked="" type="radio"/> Inventor		<input type="radio"/> Legal Representative under 35 U.S.C. 117		<input type="radio"/> Party of Interest under 35 U.S.C. 118	
Prefix	Given Name	Middle Name	Family Name	Suffix	
	Chin-Lung		Li		
Residence Information (Select One) <input type="radio"/> US Residency <input checked="" type="radio"/> Non US Residency <input type="radio"/> Active US Military Service					
City	Taoyuan County	Country Of Residenceⁱ	TW		
Citizenship under 37 CFR 1.41(b)ⁱ		TW			
Mailing Address of Applicant:					
Address 1	No.4, Ln. 99, Sec. 1, Shengde Rd., Zhongli City,				
Address 2					
City	Taoyuan County	State/Province			
Postal Code		Countryⁱ	TW		
Applicant 3					Remove
Applicant Authority <input checked="" type="radio"/> Inventor		<input type="radio"/> Legal Representative under 35 U.S.C. 117		<input type="radio"/> Party of Interest under 35 U.S.C. 118	
Prefix	Given Name	Middle Name	Family Name	Suffix	
	Shun-Nan		Liou		
Residence Information (Select One) <input type="radio"/> US Residency <input checked="" type="radio"/> Non US Residency <input type="radio"/> Active US Military Service					
City	Kaohsiung City	Country Of Residenceⁱ	TW		

Under the Paperwork Reduction Act of 1995, no persons are required to respond to a collection of information unless it contains a valid OMB control number.

Application Data Sheet 37 CFR 1.76		Attorney Docket Number	35822-US-PA-0P-2	
		Application Number		
Title of Invention	3D POINTING DEVICE AND METHOD FOR COMPENSATING ROTATIONS OF THE 3D POINTING DEVICE THEREOF			
Citizenship under 37 CFR 1.41(b) i	TW			
Mailing Address of Applicant:				
Address 1	No. 28, Ln. 341, Gangshan N. St., Qianzhen Dist.,			
Address 2				
City	Kaohsiung City		State/Province	
Postal Code		Countryⁱ	TW	
All Inventors Must Be Listed - Additional Inventor Information blocks may be generated within this form by selecting the Add button.				<input type="button" value="Add"/>

Correspondence Information:

Enter either Customer Number or complete the Correspondence Information section below. For further information see 37 CFR 1.33(a) .			
<input type="checkbox"/> An Address is being provided for the correspondence information of this application.			
Customer Number	31561		
Email Address	USA@JCIPGROUP.COM.TW	<input type="button" value="Add Email"/>	<input type="button" value="Remove Email"/>
Email Address	BELINDA@JCIPGROUP.COM.TW	<input type="button" value="Add Email"/>	<input type="button" value="Remove Email"/>

Application Information:

Title of the Invention	3D POINTING DEVICE AND METHOD FOR COMPENSATING ROTATIONS OF THE 3D POINTING DEVICE THEREOF		
Attorney Docket Number	35822-US-PA-0P-2	Small Entity Status Claimed	<input checked="" type="checkbox"/>
Application Type	Nonprovisional		
Subject Matter	Utility		
Suggested Class (if any)		Sub Class (if any)	
Suggested Technology Center (if any)			
Total Number of Drawing Sheets (if any)	12	Suggested Figure for Publication (if any)	

Publication Information:

<input type="checkbox"/> Request Early Publication (Fee required at time of Request 37 CFR 1.219)
<input type="checkbox"/> Request Not to Publish. I hereby request that the attached application not be published under 35 U.S.C. 122(b) and certify that the invention disclosed in the attached application has not and will not be the subject of an application filed in another country, or under a multilateral international agreement, that requires publication at eighteen months after filing.

Representative Information:

Representative information should be provided for all practitioners having a power of attorney in the application. Providing this information in the Application Data Sheet does not constitute a power of attorney in the application (see 37 CFR 1.32). Enter either Customer Number or complete the Representative Name section below. If both sections are completed the Customer Number will be used for the Representative Information during processing.

Application Data Sheet 37 CFR 1.76		Attorney Docket Number	35822-US-PA-0P-2
		Application Number	
Title of Invention	3D POINTING DEVICE AND METHOD FOR COMPENSATING ROTATIONS OF THE 3D POINTING DEVICE THEREOF		
Please Select One:			
	<input checked="" type="radio"/> Customer Number	<input type="radio"/> US Patent Practitioner	<input type="radio"/> Limited Recognition (37 CFR 11.9)
Customer Number	31561		

Domestic Benefit/National Stage Information:

This section allows for the applicant to either claim benefit under 35 U.S.C. 119(e), 120, 121, or 365(c) or indicate National Stage entry from a PCT application. Providing this information in the application data sheet constitutes the specific reference required by 35 U.S.C. 119(e) or 120, and 37 CFR 1.78(a)(2) or CFR 1.78(a)(4), and need not otherwise be made part of the specification.

Prior Application Status	Pending	Remove	
Application Number	Continuity Type	Prior Application Number	Filing Date (YYYY-MM-DD)
	Continuation in part of	13072794	2011-03-28
Prior Application Status	Pending	Remove	
Application Number	Continuity Type	Prior Application Number	Filing Date (YYYY-MM-DD)
13072794	Continuation in part of	12943934	2010-11-11
Prior Application Status	Pending	Remove	
Application Number	Continuity Type	Prior Application Number	Filing Date (YYYY-MM-DD)
12943934	non provisional of	61292558	2010-01-06
Additional Domestic Benefit/National Stage Data may be generated within this form by selecting the Add button.			Add

Foreign Priority Information:

This section allows for the applicant to claim benefit of foreign priority and to identify any prior foreign application for which priority is not claimed. Providing this information in the application data sheet constitutes the claim for priority as required by 35 U.S.C. 119(b) and 37 CFR 1.55(a).

			Remove
Application Number	Country ⁱ	Parent Filing Date (YYYY-MM-DD)	Priority Claimed
			<input type="radio"/> Yes <input checked="" type="radio"/> No
Additional Foreign Priority Data may be generated within this form by selecting the Add button.			Add

Assignee Information:

Providing this information in the application data sheet does not substitute for compliance with any requirement of part 3 of Title 37 of the CFR to have an assignment recorded in the Office.

		Remove
Assignee 1		
If the Assignee is an Organization check here. <input checked="" type="checkbox"/>		
Organization Name	Cywee Group Ltd.	

Application Data Sheet 37 CFR 1.76		Attorney Docket Number	35822-US-PA-0P-2
		Application Number	
Title of Invention	3D POINTING DEVICE AND METHOD FOR COMPENSATING ROTATIONS OF THE 3D POINTING DEVICE THEREOF		

Mailing Address Information:			
Address 1	3F., No.28, Ln. 128, Jingye 1st Rd.,		
Address 2	Zhongshan Dist.,		
City	Taipei City	State/Province	
Country i	TW	Postal Code	104
Phone Number		Fax Number	
Email Address			
Additional Assignee Data may be generated within this form by selecting the Add button.			<input type="button" value="Add"/>

Signature:

A signature of the applicant or representative is required in accordance with 37 CFR 1.33 and 10.18. Please see 37 CFR 1.4(d) for the form of the signature.					
Signature	/Belinda Lee/			Date (YYYY-MM-DD)	2011-07-06
First Name	Belinda	Last Name	Lee	Registration Number	46863

This collection of information is required by 37 CFR 1.76. The information is required to obtain or retain a benefit by the public which is to file (and by the USPTO to process) an application. Confidentiality is governed by 35 U.S.C. 122 and 37 CFR 1.14. This collection is estimated to take 23 minutes to complete, including gathering, preparing, and submitting the completed application data sheet form to the USPTO. Time will vary depending upon the individual case. Any comments on the amount of time you require to complete this form and/or suggestions for reducing this burden, should be sent to the Chief Information Officer, U.S. Patent and Trademark Office, U.S. Department of Commerce, P.O. Box 1450, Alexandria, VA 22313-1450. DO NOT SEND FEES OR COMPLETED FORMS TO THIS ADDRESS. **SEND TO: Commissioner for Patents, P.O. Box 1450, Alexandria, VA 22313-1450.**

Privacy Act Statement

The Privacy Act of 1974 (P.L. 93-579) requires that you be given certain information in connection with your submission of the attached form related to a patent application or patent. Accordingly, pursuant to the requirements of the Act, please be advised that: (1) the general authority for the collection of this information is 35 U.S.C. 2(b)(2); (2) furnishing of the information solicited is voluntary; and (3) the principal purpose for which the information is used by the U.S. Patent and Trademark Office is to process and/or examine your submission related to a patent application or patent. If you do not furnish the requested information, the U.S. Patent and Trademark Office may not be able to process and/or examine your submission, which may result in termination of proceedings or abandonment of the application or expiration of the patent.

The information provided by you in this form will be subject to the following routine uses:

1. The information on this form will be treated confidentially to the extent allowed under the Freedom of Information Act (5 U.S.C. 552) and the Privacy Act (5 U.S.C. 552a). Records from this system of records may be disclosed to the Department of Justice to determine whether the Freedom of Information Act requires disclosure of these records.
2. A record from this system of records may be disclosed, as a routine use, in the course of presenting evidence to a court, magistrate, or administrative tribunal, including disclosures to opposing counsel in the course of settlement negotiations.
3. A record in this system of records may be disclosed, as a routine use, to a Member of Congress submitting a request involving an individual, to whom the record pertains, when the individual has requested assistance from the Member with respect to the subject matter of the record.
4. A record in this system of records may be disclosed, as a routine use, to a contractor of the Agency having need for the information in order to perform a contract. Recipients of information shall be required to comply with the requirements of the Privacy Act of 1974, as amended, pursuant to 5 U.S.C. 552a(m).
5. A record related to an International Application filed under the Patent Cooperation Treaty in this system of records may be disclosed, as a routine use, to the International Bureau of the World Intellectual Property Organization, pursuant to the Patent Cooperation Treaty.
6. A record in this system of records may be disclosed, as a routine use, to another federal agency for purposes of National Security review (35 U.S.C. 181) and for review pursuant to the Atomic Energy Act (42 U.S.C. 218(c)).
7. A record from this system of records may be disclosed, as a routine use, to the Administrator, General Services, or his/her designee, during an inspection of records conducted by GSA as part of that agency's responsibility to recommend improvements in records management practices and programs, under authority of 44 U.S.C. 2904 and 2906. Such disclosure shall be made in accordance with the GSA regulations governing inspection of records for this purpose, and any other relevant (i.e., GSA or Commerce) directive. Such disclosure shall not be used to make determinations about individuals.
8. A record from this system of records may be disclosed, as a routine use, to the public after either publication of the application pursuant to 35 U.S.C. 122(b) or issuance of a patent pursuant to 35 U.S.C. 151. Further, a record may be disclosed, subject to the limitations of 37 CFR 1.14, as a routine use, to the public if the record was filed in an application which became abandoned or in which the proceedings were terminated and which application is referenced by either a published application, an application open to public inspections or an issued patent.
9. A record from this system of records may be disclosed, as a routine use, to a Federal, State, or local law enforcement agency, if the USPTO becomes aware of a violation or potential violation of law or regulation.

3D POINTING DEVICE AND METHOD FOR COMPENSATING ROTATIONS OF
THE 3D POINTING DEVICE THEREOF

5 CROSS-REFERENCE TO RELATED APPLICATION

This application is a continuation in part application of and claims the priority benefit of U.S. application serial no. 13/072,794, filed on Mar. 28, 2011, now pending. The prior application serial no. 13/072,794 is a continuation in part application of and claims the priority benefit of U.S. application serial no. 12/943,934, filed on November 10 11, 2010, now pending, which claims the priority benefit of U.S. provisional application serial no. 61/292,558, filed on January 6, 2010. The entirety of each of the above-mentioned patent applications is hereby incorporated by reference herein and made a part of this specification.

15 BACKGROUND OF THE INVENTION

Field of the Invention

[0001] The present invention generally relates to a 3D pointing device, more particularly to a 3D pointing device for use in computers, motion detection or navigation utilizing a orientation sensor and a method for compensating signals of the orientation sensor subject to movements and rotations of said 3D pointing device. 20

Description of the Related Art

[0002] Fig. 1 is a schematic diagram showing a user using a portable electronic device 110, such as a 3D pointing device or computer mouse, for detecting motions of 25 the device and translating the detected motions to a cursor display such as a cursor

pointing on the screen 122 of a 2D display device 120. If the pointing device 110 emits a light beam, the corresponding point would be the location where the light beam hits the screen 122. For example, the pointing device 110 may be a mouse of a computer or a pad of a video game console. The display device 120 may be a part of the computer or the video game console. There are two reference frames, such as the spatial pointer reference frame and the display frame, associated with the pointing device 110 and the display device 120, respectively. The first reference frame or spatial pointer reference frame associated with the pointing device 110 is defined by the coordinate axes X_P , Y_P and Z_P as shown in Fig. 1. The second reference frame or display frame associated with the display device 120 is defined by the coordinate axes X_D , Y_D and Z_D as shown in Fig. 1. The screen 122 of the display device 120 is a subset of the $X_D Y_D$ plane of the reference frame $X_D Y_D Z_D$ associated with the display device 120. Therefore, the $X_D Y_D$ plane is also known as the display plane associated with the display device 120.

[0003] A user may perform control actions and movements utilizing the pointing device for certain purposes including entertainment such as playing a video game, on the display device 120 through the aforementioned pointer on the screen 122. For proper interaction with the use of the pointing device, when the user moves the pointing device 110, the pointer on the screen 122 is expected to move along with the orientation, direction and distance travelled by the pointing device 110 and the display 120 shall display such movement of the pointer to a new location on the screen 122 of the display 120. The orientation of the pointing device 110 may be represented by three deviation angles of the 3D pointing device 110 with respect to the reference frame $X_P Y_P Z_P$, namely, the yaw angle 111, the pitch angle 112 and the roll angle 113. The yaw, pitch

and roll angles 111, 112, 113 may be best understood in relation to the universal standard definition of spatial angles related to commercial vehicles or transportation such as ships and airplanes. Conventionally, the yaw angle 111 may represent the rotation of the pointing device 110 about the Z_P axis; the pitch angle 112 may represent the rotation of the pointing device 110 about the Y_P axis; the roll angle 113 may represent the rotation of the pointing device 110 about the X_P axis.

[0004] In a known related art as shown in Fig. 1, when the yaw angle 111 of the pointing device 110 changes, the aforementioned pointer on the screen 122 must move horizontally or in a horizontal direction with reference to the ground in response to the change of the yaw angle 111. Fig. 2 shows what happens when the user rotates the pointing device 110 counterclockwise by a degree such as a 90-degree about the X_P axis. In another known related art as shown in Fig. 2, when the yaw angle 111 changes, the aforementioned pointer on the screen 122 is expected to move vertically in response. The change of the yaw angle 111 can be detected by a gyro-sensor which detects the angular velocity ω_x of the pointing device 110 about the X_P axis. Fig. 1 and Fig. 2 show that the same change of the yaw angle 111 may be mapped to different movements of the point on the screen 122. Therefore, a proper compensation mechanism for the orientation of the pointing device 110 is required such that corresponding mapping of the pointer on the screen 122 of the display 120 may be obtained correctly and desirably. The term compensation of the prior arts by Liberty (US Patent No. 7,158,118, US Patent No. 7,262,760 and US Patent No. 7,414,611) refers to the correction and compensation of signals subject to gravity effects or extra rotations about the axis related to "roll". The term of "comparison" of the present invention may generally

refer to the calculating and obtaining of the actual deviation angles of the 3D pointing device 110 with respect to the first reference frame or spatial pointing frame $X_P Y_P Z_P$ utilizing signals generated by motion sensors while reducing or eliminating noises associated with said motion sensors; whereas the term mapping may refer to the calculating and translating of said deviation angles in the spatial pointing frame $X_P Y_P Z_P$ onto the aforementioned pointer on the display plane associated with the 2D display device 120 of a second reference frame or display frame $X_D Y_D Z_D$.

[0005] It is known that a pointing device utilizing 5-axis motion sensors, namely, A_x , A_y , A_z , ω_Y and ω_Z may be compensated. For example, US Patent No. 7,158,118 by Liberty, US Patent 7,262,760 by Liberty and US 7,414,611 by Liberty provide such pointing device having a 5-axis motion sensor and discloses a compensation using two gyro-sensors ω_Y and ω_Z to detect rotation about the Y_p and Z_p axes, and accelerometers A_x , A_y and A_z to detect the acceleration of the pointing device along the three axes of the reference frame $X_P Y_P Z_P$. The pointing device by Liberty utilizing a 5-axis motion sensor may not output deviation angles of the pointing device in, for example, a 3D reference frame; in other words, due to the limitation of the 5-axis motion sensor of accelerometers and gyro-sensors utilized therein, the pointing device by Liberty cannot output deviation angles readily in 3D reference frame but rather a 2D reference frame only and the output of such device having 5-axis motion sensors is a planar pattern in 2D reference frame only. In addition, it has been found that the pointing device and compensation disclosed therein cannot accurately or properly calculate or obtain movements, angles and directions of the pointing device while being subject to undesirable interferences, external or internal, in the dynamic environment

during the obtaining of the signals generated by the motion sensors, in particular, during unexpected drifting movements and/or accelerations along with the direction of gravity. In other words, it has been found that dynamic actions or extra accelerations including additional accelerations, in particular the one acted upon the direction substantially parallel to or along with the gravity imposed on the pointing device with the compensation methods provided by Liberty, said pointing device by Liberty cannot properly or accurately output the actual yaw, pitch and roll angles in the spatial reference frame $X_P Y_P Z_P$ and following which, consequently, the mapping of the spatial angles onto any 2D display reference frame such as $X_D Y_D Z_D$ may be greatly affected and erred. To be more specific, as the 5-axis compensation by Liberty cannot detect or compensate rotation about the X_P axis directly or accurately, the rotation about the X_P axis has to be derived from the gravitational acceleration detected by the accelerometer. Furthermore, the reading of the accelerometer may be accurate only when the pointing device is static since due to the limitation on known accelerometers that these sensors may not distinguish the gravitational acceleration from the acceleration of the forces including centrifugal forces or other types of additional accelerations imposed or exerted by the user.

[0006] Furthermore, it has been found that known prior arts may only be able to output a “relative” movement pattern in a 2D reference frame based on the result calculated from the signals of motion sensors. For example, the abovementioned prior arts by Liberty may only output a 2D movement pattern in a relative manner and a pointer on a display screen to show such corresponding 2D relative movement pattern. To be more specific, the pointer moves from a first location to a second new location

relative to said first location only. Such relative movement from the previous location to the next location with respect to time cannot accurately determine and/or output the next location, particularly in situations where the previous location may have been an erred location or have been faultily determined as an incorrect reference point for the next location that is to be calculated therefrom and obtained based on their relative relationship adapted. One illustration of such defect of known prior arts adapting a relative relationship in obtaining a movement pattern may be clearly illustrated by an example showing the faultily outputted movements of a pointer intended to move out of a boundary or an edge of display screen. It has been found that as the pointer of known prior arts reaches the edge of a display and continues to move out of the boundary or edge at a certain extra extent beyond said boundary, the pointer fails to demonstrate a correct or “absolute” pattern as it moves to a new location either within the display or remaining outside of the boundary; in other words, instead of returning to a new location by taking into account said certain extra extend beyond the boundary made earlier in an “absolute” manner, the pointer of known arts discards such virtual distance of the extra extend beyond the boundary already made and an erred next position is faultily outputted due to the relative relationship adapted and utilized by the pointer.

[0007] Therefore, it is clear that an improved device for use in for example motion detection, computers or navigation with enhanced calculating or comparison method capable of accurately obtaining and calculating actual deviation angles in the spatial pointer frame is needed. For applications of navigations or computers including portable communication devices integrated with displays therein, the electronic device may too include the mapping of such actual angles onto a cursor, pointer or position information

on the display frame in dynamic environments and conditions including undesirable external interferences. In addition, as the trend of 3D technology advances and is applicable to various fields including displays, interactive systems and navigation, there is a significant need for an electronic device, including for example a motion detector, a 3D pointing device, a navigation equipment, or a communication device integrated with motion sensors therein, capable of accurately outputting a deviation of such device readily useful in a 3D or spatial reference frame. Furthermore, there is a need to provide an enhanced comparison method and/or model applicable to the processing of signals of motion sensors such that errors and/or noises associated with such signals or fusion of signals from the motions sensors may be corrected or eliminated. In addition, according to the field of application, such output of deviation in 3D reference frame may too be further mapped or translated to a pattern useful in a 2D reference frame.

SUMMARY OF THE INVENTION

[0008] According to one aspect of an exemplary embodiment of the present invention, an electronic device utilizing a nine-axis motion sensor module for use in for example computers, motion detection or navigation is provided. The electronic device comprises an accelerometer to measure or detect axial accelerations A_x , A_y , A_z , a magnetometer to measure or detect magnetism M_x , M_y , M_z and a rotation sensor to measure or detect angular velocities ω_x , ω_y , ω_z such that resulting deviation including resultant angles comprising yaw, pitch and roll angles in a spatial pointer frame of the electronic device subject to movements and rotations in dynamic environments may be obtained and such that said resulting deviation including said resultant angles may be obtained and outputted in an absolute manner reflecting or associating with the actual movements and

rotations of the electronic device of the present invention in said spatial pointer reference frame and preferably excluding undesirable external interferences in the dynamic environments.

5 **[0009]** According to another aspect of the present invention, the present invention provides an enhanced comparison method and/or model to eliminate the accumulated errors as well as noises over time associated with signals generated by a combination of motion sensors, including the ones generated by accelerometers A_x , A_y , A_z , the ones generated by magnetometers M_x , M_y , M_z and the ones generated by gyroscopes ω_x , ω_y ,
10 ω_z in dynamic environments. In other words, accumulated errors associated with a fusion of signals from a motions sensor module comprising a plurality of motion sensors to detect movements on and rotations about different axes of a reference frame may be eliminated or corrected.

15 **[0010]** According to still another aspect of the present invention, the present invention provides an enhanced comparison method to correctly calculating and outputting a resulting deviation comprising a set of resultant angles including yaw, pitch and roll angles in a spatial pointer frame, preferably about each of three orthogonal coordinate axes of the spatial pointer reference frame, by comparing signals of rotation
20 sensor related to angular velocities or rates with the ones of accelerometer related to axial accelerations and the ones of magnetometer related to magnetism such that these angles may be accurately outputted and obtained, which may too be further mapping to another reference frame different from said spatial pointer frame.

25 **[0011]** In the event of interferences including external interferences introduced by

either the device user or the surrounding environment, such as external electromagnetic fields, according to still another aspect of the present invention, the present invention provides a unique update program comprising a data association model to intelligently process signals received from a motion sensor module to output a resultant deviation preferably in 3D reference frame such that the adverse effects caused by the interferences may be advantageously reduced or compensated.

[0012] According to still another aspect of the present invention, the present invention further provides a mapping of the abovementioned resultant angles, preferably about each of three orthogonal coordinate axes of the spatial pointer reference frame, including yaw, pitch and roll angles in a spatial pointer reference frame onto a display frame either external to the device of the present invention or integrated therein such that a movement pattern in a display frame different from the spatial pointer reference frame may be obtained according to the mapping or translation of the resultant angles of the resultant deviation onto said movement pattern.

[0013] According to another example embodiment of the present invention, an electronic device capable of generating 3D deviation angles and for use in for example computers, motion detection or navigation is provided. The electronic device may utilize a nine-axis motion sensor module with an enhanced comparison method or model for eliminating accumulated errors of said nine-axis motion sensor module to obtain deviation angles corresponding to movements and rotations of said electronic device in a spatial pointer reference frame. The comparison method or model may be advantageously provided by comparing signals from the abovementioned nine-axis motion sensor module capable of detecting rotation rates or angular velocities of the

electronic device about all of the X_P , Y_P and Z_P axes as well as axial accelerations and ambient magnetism including such as earth's magnetic field or that of other planets of the electronic device along all of the X_P , Y_P and Z_P axes such that deviation angles of the resultant deviation of the electronic device of the present invention may be preferably obtained or outputted in an absolute manner. In other words, the present invention is capable of accurately outputting the abovementioned deviation angles including yaw, pitch and roll angles in a 3D spatial pointer reference frame of the 3D pointing device to eliminate or reduce accumulated errors and noises generated over time in a dynamic environment including conditions such as being subject to a combination of continuous movements, rotations, external gravity forces, magnetic field and additional extra accelerations in multiple directions or movement and rotations that are continuously nonlinear with respect to time; and furthermore, based on the deviation angles being compensated and accurately outputted in 3D spatial reference frame may be further mapped onto or translated into another reference frame such as the abovementioned display frame, for example a reference in two-dimension (2D).

[0014] According to another example embodiment of the present invention, a 3D pointing device utilizing a nine-axis motion sensor module is provided; wherein the nine-axis motion sensor module of the 3D pointing device comprises at least one gyroscope, at least one accelerometer and at least one magnetometer. In one preferred embodiment of the present invention, the nine-axis motion sensor module comprises a rotation sensor capable of detecting and generating angular velocities of ω_x , ω_y , ω_z , an accelerometer capable of detecting and generating axial accelerations of A_x , A_y , A_z , and a magnetometer capable of detecting and generating magnetism of M_x , M_y , M_z . It

can be understood that in another embodiment, the abovementioned rotation sensor may comprise three gyroscopes corresponding to each of the said angular velocities of ω_x , ω_y , ω_z in a 3D spatial reference frame of the 3D pointing device; whereas the abovementioned accelerometer may comprise three accelerometers corresponding to each of the said axial accelerations A_x , A_y , A_z in a 3D spatial reference frame of the 3D pointing device; and whereas the abovementioned magnetometer may comprise three magnetic sensors such as magneto-impedance (MI) sensors or magneto-resistive (MR) sensors corresponding to each of the said magnetism M_x , M_y , M_z in a 3D spatial reference frame of the electronic device. The rotation sensor detects the rotation of the 3D pointing device with respect to a reference frame associated with the 3D pointing device and provides a rotation rate or angular velocity output. The angular velocity output includes three components corresponding to the rotation rate or angular velocities ω_x , ω_y , ω_z of the 3D pointing device about the first axis, the second axis and the third axis of the reference frame, namely, X_p , Y_p and Z_p of the 3D spatial frame. The accelerometer detects the axial accelerations of the 3D pointing device with respect to the spatial reference frame such as a 3D-pointer reference frame and provides an acceleration output. The acceleration output includes three components corresponding to the accelerations, A_x , A_z , A_y of the 3D pointing device along the first axis, the second axis and the third axis of the reference frame, namely, X_p , Y_p and Z_p of the 3D spatial reference frame. The magnetometer detects the magnetism of the electronic device with respect to the spatial reference frame such as a 3D reference frame and provides an magnetism output. The magnetism output includes three components corresponding to the magnetism, M_x , M_y , M_z of the 3D pointing device along the first axis, the second axis and the third axis of the reference frame, namely, X_p , Y_p and Z_p

of the 3D spatial frame. It can, however, be understood that the axes of X_p , Y_p and Z_p of the 3D spatial reference frame may too be represented simply by the denotation of X, Y and Z.

5 [0015] According to another example embodiment of the present invention, a method for compensating accumulated errors of signals of the abovementioned nine-axis motion sensor module in dynamic environments associated in a spatial reference frame is provided. In one embodiment, the method may be performed or handled by a hardware processor. The processor is capable of compensating the accumulated errors associated
10 with the resultant deviation in relation to the signals of the abovementioned nine-axis motion sensor module of the 3D pointing device subject to movements and rotations in a spatial reference frame and in a dynamic environment by performing a data comparison to compare signals of rotation sensor related to angular velocities with the ones of accelerometer related to axial accelerations and the ones of magnetometer
15 related to magnetism such that the resultant deviation corresponding to the movements and rotations of the 3D pointing device in the 3D spatial reference frame may be obtained accurately over time in the dynamic environments.

[0016] According to another embodiment of the present invention, a method for
20 obtaining a resulting deviation including resultant angles in a spatial reference frame of a three-dimensional (3D) pointing device utilizing a nine-axis motion sensor module therein and subject to movements and rotations in dynamic environments in said spatial reference frame is provided. Said method comprises the steps of: obtaining a previous state associated with previous angular velocities ω_x , ω_y , ω_z gained from the motion

sensor signals of the nine-axis motion sensor module at a previous time T-1; obtaining a current state of the nine-axis motion sensor module by obtaining measured angular velocities ω_x , ω_y , ω_z gained from the motion sensor signals at a current time T; obtaining a measured state of the nine-axis motion sensor module by obtaining measured axial accelerations A_x , A_y , A_z and measured magnetism M_x , M_y , M_z gained from the motion sensor signals at the current time T and calculating predicted axial accelerations A_x' , A_y' , A_z' and predicted magnetism M_x' , M_y' , M_z' based on the measured angular velocities ω_x , ω_y , ω_z of the current state; obtaining an updated state of the nine-axis motion sensor module by comparing the current state with the measured state of the nine-axis motion sensor module; and calculating and converting the updated state of the nine-axis motion sensor module to said resulting deviation comprising said resultant angles in said spatial reference frame of the 3D pointing device.

[0017] According to another aspect of the present invention, a method for mapping deviation angles associated with movements and rotations of a 3D pointing device in a spatial reference frame onto a display frame of a display having a predetermined screen size is provided. In one embodiment, the method for mapping or translating deviation angles including yaw, pitch and roll angles in a spatial reference frame to an pointing object, such as a pointer, having movements in a display frame, preferably a 2D reference frame, comprises the steps of obtaining boundary information of the display frame by calculating a predefined sensitivity associated with the display frame and performing angle and distance translation in the display frame based on said deviation angles and boundary information.

[0018] According to another embodiment of the present invention, a method for obtaining a resulting deviation including resultant angles in a spatial reference frame of a three-dimensional pointing device utilizing a nine-axis motion sensor module therein and subject to movements and rotations in dynamic environments in said spatial reference frame is provided. Said method comprises the steps of: obtaining a previous state of the nine-axis motion sensor module; wherein the previous state includes an initial-value set associated with at least previous angular velocities gained from the motion sensor signals of the nine-axis motion sensor module at a previous time T-1; obtaining a current state of the nine-axis motion sensor module by obtaining measured angular velocities ω_x , ω_y , ω_z gained from the motion sensor signals of the nine-axis motion sensor module at a current time T; obtaining a measured state of the nine-axis motion sensor module by obtaining measured axial accelerations A_x , A_y , A_z gained from the motion sensor signals of the nine-axis motion sensor module at the current time T and calculating predicted axial accelerations A_x' , A_y' , A_z' based on the measured angular velocities ω_x , ω_y , ω_z of the current state of the nine-axis motion sensor module; obtaining a first updated state of the nine-axis motion sensor module by comparing the current state with the measured state of the nine-axis motion sensor module; obtaining the measured state of the nine-axis motion sensor module by obtaining and calculating a measured yaw angle gained from the motion sensor signals of the nine-axis motion sensor module at the current time T and calculating a predicted yaw angle based on the first updated state of the nine-axis motion sensor module; obtaining a second updated state of the nine-axis motion sensor module by comparing the current state with the measured state of the nine-axis motion sensor module; and calculating and converting the second updated state of the nine-axis motion sensor

module to said resulting deviation comprising said resultant angles in said spatial reference frame of the electronic device.

5 [0019] According to another aspect of the present invention, a 3D pointing device is provided, which includes an orientation sensor, a rotation sensor, and a computing processor. The orientation sensor generates an orientation output associated with an orientation of the 3D pointing device associated with three coordinate axes of a global reference frame associated with the Earth. The rotation sensor generates a rotation output associated with a rotation of the 3D pointing device associated with three
10 coordinate axes of a spatial reference frame associated with the 3D pointing device. The computing processor uses the orientation output and the rotation output to generate a transformed output associated with a fixed reference frame associated with a display device.

15 [0020] According to another aspect of the present invention, a method for compensating the rotations of a 3D pointing device is provided. The method includes the following steps. Generate an orientation output associated with an orientation of the 3D pointing device associated with three coordinate axes of a global reference frame associated with the Earth. Generate a rotation output associated with the rotation of the
20 3D pointing device associated with three coordinate axes of a spatial reference frame associated with the 3D pointing device. Use the orientation output and the rotation output to generate a transformed output associated with a fixed reference frame associated with a display device.

BRIEF DESCRIPTION OF THE DRAWINGS

5 [0021] The accompanying drawings are included to provide a further understanding of the invention, and are incorporated herein for illustrative purposes only. The drawings illustrate embodiments of the invention and, together with the description, serve to only illustrate the principles of the invention.

[0022] FIG. 1 shows a known related art having a 5-axis motion sensor in 2D reference frame.

10 [0023] FIG. 2 shows the known related art having a 5-axis motion sensor as shown in FIG.1 being rotated or rolled about X_p axis and is subject to further dynamic interactions or environment.

15 [0024] FIG. 3 is an exploded diagram showing an electronic device of the present invention, such as a pointing device, utilizing a nine-axis motion sensor module according to one embodiment of the present invention.

[0025] FIG. 4 is a schematic block diagram illustrating hardware components of an electronic device according to one embodiment of the present invention.

20 [0026] FIG. 5 is a schematic diagram showing another embodiment of an electronic device of the present invention, such as a pointing device, utilizing a nine-axis motion sensor module as well as an external processor.

25 [0027] FIG. 6 is an exploded diagram showing still another embodiment of an electronic device of the present invention, such as a smartphone or navigation

equipment, utilizing a nine-axis motion sensor module according to another embodiment of the present invention.

5 [0028] FIG. 7 is a flow chart illustrating a method for obtaining a resultant deviation of an electronic device of the present invention subject to movements and rotations in a spatial reference frame.

10 [0029] FIG. 8 shows another exemplary flow chart illustrating a method for obtaining resultant deviation including mapping of said deviation to a display of an electronic device according to another embodiment of the present invention.

[0030] FIG. 9 is a schematic diagram showing the mapping of the resultant angles of the resultant deviation according to an embodiment of the present invention.

15 [0031] FIG. 10 is an exemplary flow chart illustrating another embodiment of a method for obtaining a resultant deviation of an electronic device of the present invention.

20 [0032] FIG. 11 shows an exemplary flow chart illustrating another embodiment of a method for obtaining a resultant deviation including mapping of such deviation to a display of an electronic device of the present invention.

25 [0033] FIG. 12 shows an exemplary flow chart illustrating a method for obtaining resultant deviation of an electronic device according to still another embodiment of the present invention.

[0034] FIG. 13 is a flow chart of a method for compensating rotations of a 3D pointing device according to an embodiment of the present invention.

[0035] FIG. 14, FIG. 15 and FIG. 16 are schematic diagrams showing three 3D pointing devices according to three different embodiments of the present invention.

DESCRIPTION OF PREFERRED EMBODIMENTS

[0036] Detailed descriptions of preferred embodiments of the present invention recited herein are provided for illustrative purposes only; examples of which are too illustrated in the accompanying drawings. In addition, similar reference numbers in the drawings and the description may too refer to similar parts or components.

[0037] FIG. 3 is an exploded diagram showing an electronic device 300 according to one embodiment of the present invention, such as a pointing device. The electronic device 300 is subject to movements and rotations in dynamic environments in a spatial reference frame such as a 3D reference frame. The spatial reference frame is analogous to the reference frame $X_P Y_P Z_P$ also shown in Fig. 1 and Fig. 2. The movements and rotations of the electronic device 300, such as a pointing device, in the aforementioned dynamic environments in the spatial reference frame may be continuously nonlinear with respect to time. The term of “dynamic” recited herein may refer to moving or subject to motions in general.

[0038] The electronic device 300 includes a top cover 310, a printed circuit board (PCB) 340, a rotation sensor 342, an accelerometer 344, a magnetometer 345, a data

transmitting unit 346, a computing processor 348, a bottom cover 320, and a battery pack 322. The top cover 310 may include a few control buttons 312 for a user to issue predefined commands for remote control. In one embodiment, the housing 330 may comprise the top cover 310 and the bottom cover 320. The housing 330 may move and rotate in the spatial reference frame according to user manipulation or any external forces in any direction and/or under the abovementioned dynamic environments. As shown in the FIG.3, in one embodiment, the rotation sensor 342, the accelerometer 344, the magnetometer 345, the data transmitting unit 346, and the computing processor 348 may be all attached to the PCB 340. The PCB 340 is enclosed by the housing 330. The PCB 340 includes at least one substrate having a longitudinal side configured to be substantially parallel to the longitudinal surface of the housing 330. An additional battery pack 322 provides electrical power for the electronic device 300.

[0039] Furthermore, in one embodiment, the abovementioned dynamic environments, in which the electronic device 300 of the present invention may be present or subject to, may include undesirable external interferences to the electronic device 300 of the present invention. In one example, the undesirable external interferences may refer to or include undesirable axial accelerations caused by undesirable external forces other than a force of gravity. In another example, the undesirable external interferences may also refer to or include undesirable magnetism caused by undesirable electromagnetic fields.

[0040] FIG. 4 is a schematic block diagram illustrating hardware components of the electronic device 300. The electronic device 300 includes a nine-axis motion sensor module 302 and a processing and transmitting module 304. The nine-axis motion sensor

module 302 includes the rotation sensor 342, the accelerometer 344 and the magnetometer 345. The processing and transmitting module 304 includes the data transmitting unit 346 and the computing processor 348.

5 [0041] The term "nine-axis" recited herein may refer to and generally include the three angular velocities ω_x , ω_y , ω_z , the three axial accelerations A_x , A_y , A_z , and the three magnetism M_x , M_y , M_z . The rotation sensor 342 of the nine-motion sensor module 302 detects and generates the first signal set including angular velocities ω_x , ω_y , ω_z associated with the movements and rotations of the electronic device 300 about each
10 of three orthogonal coordinate axes $X_P Y_P Z_P$ of the spatial reference frame. The angular velocities ω_x , ω_y and ω_z are corresponding to the coordinate axes X_P , Y_P and Z_P respectively. The accelerometer 344 detects and generates the second signal set including axial accelerations A_x , A_y , A_z associated with the movements and rotations of the electronic device 300 along each of the three orthogonal coordinate axes $X_P Y_P Z_P$
15 of the spatial reference frame. The axial accelerations A_x , A_y and A_z are corresponding to the coordinate axes X_P , Y_P and Z_P respectively. The magnetometer 345 of the nine-motion sensor module 302 detects and generates the third signal set including magnetism M_x , M_y , M_z associated with the movements and rotations of the electronic device 300 along each of the three orthogonal coordinate axes $X_P Y_P Z_P$ of the spatial
20 reference frame. The magnetism M_x , M_y and M_z represent the strength and/or direction of ambient magnetic field (such as the magnetic field of the Earth) of the electronic device 300. The magnetism M_x , M_y and M_z are corresponding to the coordinate axes X_P , Y_P and Z_P respectively. It too can be understood that the abovementioned nine axes of $X_P Y_P Z_P$ may not need to be orthogonal in a specific orientation and they may be

rotated in different orientations; the present invention discloses such coordinate system for illustrative purposes only and any coordinates in different orientation and/or denotations may too be possible.

5 [0042] Furthermore, in one embodiment of the present invention, the motion sensor module or nine-axis motion sensor module 302 of the electronic device 300 may refer to a Micro-Electro-Mechanical-System (MEMS) type of sensor. In an explanatory example, the abovementioned rotation sensor 342 of the nine-axis motion sensor module 302 may further comprise at least one resonating mass such that a movement of
10 said at least one resonating mass along an axis of said spatial reference frame may be detected and measured by said rotation sensor using the Coriolis acceleration effect to generate said first signal set comprising angular velocities ω_x , ω_y , ω_z in said spatial reference frame. It can be understood that for a three-axis rotation sensor of a MEMS type sensor, there may be positioned three resonating masses along each of X, Y and Z
15 axes of the spatial reference frame to generate and obtain movements or displacements of the three resonating masses thereof. It can too be understood that the nine-axis motion sensor 302 of the present invention may also include a three-axis accelerometer, a three-axis rotation sensor and a three-axis magnetometer in a MEMS structure.

20 [0043] The data transmitting unit 346 is electrically connected to the nine-axis motion sensor module 302 for transmitting the first, second and third signal sets. The data transmitting unit 346 transmits the first, second and third signal sets of the nine-axis motion sensor module 302 to the computing processor 348 preferably via electronic connections configured on the PCB 340. The computing processor 348

receives and calculates the first, second and third signal sets from the data transmitting unit 346. The computing processor 348 further communicates with the nine-axis motion sensor module 302 to calculate the resulting deviation of the electronic device 300 including three resultant angles preferably about each of the three axes of the spatial reference frame. The resultant angles include the yaw angle 111, the pitch angle 112 and the roll angle 113 as shown in Fig. 1 and Fig. 2. In order to calculate the resulting deviation, the computing processor 348 may utilize a comparison or algorithm to eliminate accumulated errors of the first, second and/or third signal sets of the nine-axis motion sensor module 302, whereby the resultant angles in the spatial reference frame, preferably about each of three orthogonal coordinate axes of the spatial reference frame, of the resulting deviation of the nine-axis motion sensor module 302 of the electronic device 300 is obtained under the aforementioned dynamic environments excluding the abovementioned undesirable external interferences and such that it is preferably obtained and outputted in an absolute manner reflecting or associating with the actual movements and rotations of the electronic device 300, including such as a pointing device, of the present invention in said spatial reference frame. In addition, said comparison utilized by the computing processor 348 may further comprise an update program to obtain an updated state of the nine-axis motion sensor module based on a previous state associated with a first signal set in relation to the angular velocities ω_x , ω_y , ω_z and a measured state associated with both said second and third signal sets in relation to the axial accelerations A_x , A_y , A_z as well as magnetism M_x , M_y , M_z . The abovementioned measured state may include a measurement of said second signal set or measured A_x , A_y , A_z and a predicted measurement of A_x' , A_y' and A_z' obtained based on or calculated from a current state of the motion sensor module 302. In addition, the

abovementioned measured state may too include a measurement of said third signal set or measured M_x , M_y , M_z and a predicted measurement of M_x' , M_y' and M_z' obtained based on or calculated from the current state of the motion sensor module 302. Details of different “states” of the nine-axis motion sensor module 302 of the electronic device 5
300 of the present invention are provided in the later content.

[0044] In one embodiment, the computing processor 348 of the processing and transmitting module 304 may further include a mapping program for translating the resultant angles of the resulting deviation in the spatial reference frame to a movement
10 pattern in a display reference frame different from the spatial reference frame. The display reference frame is analogous to the reference frame $X_D Y_D Z_D$ in Fig. 1 and Fig. 2. The movement pattern may be displayed on a screen of a 2D display device similar to the display device 120 in Fig. 1 and Fig. 2. The mapping program translates the resultant angles, preferably about each of the three orthogonal coordinate axes of the
15 spatial reference frame to the movement pattern according to a sensitivity input correlated to the display reference frame.

[0045] FIG. 5 is a schematic diagram showing an electronic device 500 utilizing a nine-axis motion sensor module according to another embodiment of the present
20 invention in a 3D spatial reference frame. As shown in FIG. 5, the electronic device 500 may comprise two parts 560 and 570 in data communication with each other. In one embodiment, the first part 560 includes a top cover (not shown), a PCB 540, a nine-axis motion sensor module 502 comprising a rotation sensor 542, an accelerometer 544 and a magnetometer 545, a data transmitting unit 546, a bottom cover 520, and a battery

pack 522. The data transmitting unit 546 transmits the first signal set ($\omega_x, \omega_y, \omega_z$) generated by the rotation sensor 542 of the nine-motion sensor module 502 and the second signal set (A_x, A_y, A_z) generated by the accelerometer 544 as well as the third signal set (M_x, M_y, M_z) generated by the magnetometer 545 of the nine-motion sensor module 502 to the data receiving unit 552 of the second part 570 via wireless communication or connection including wireless local area network (WLAN) based on IEEE 802.11 standards or Bluetooth™. It can be understood that in another embodiment, wired communication or connection via a physical cable or electrical wires connecting the first part 560 and the second part 570 may too be possible. In one embodiment of the present invention, the motion sensor module or nine-axis motion sensor module 502 of the electronic device 500 may refer to a MEMS type of sensor. In an explanatory example, the abovementioned rotation sensor 542 of the nine-axis motion sensor module 502 may further comprise at least one resonating mass such that a movement of said at least one resonating mass along an axis of said spatial reference frame may be detected and measured by said rotation sensor using the Coriolis acceleration effect to generate said first signal set comprising angular velocities $\omega_x, \omega_y, \omega_z$ in said spatial reference frame. It can be understood that for a three-axis rotation sensor of a MEMS type sensor, there may be positioned three resonating masses along each of X, Y and Z axes of the spatial reference frame to generate and obtain movements or displacements of the three resonating masses thereof. It can too be understood that the nine-axis motion sensor 502 of the present invention may also include a three-axis accelerometer, a three-axis rotation sensor and a three-axis magnetometer in a MEMS structure.

[0046] In one embodiment, the second part 570 may be an external processing device

to be adapted to another electronic computing apparatus or system such as a standalone personal computer or server 580; for instance, the second part 570 may be coupled or adapted to a laptop computer via a standard interface, such as the universal serial bus (USB) interface depicted as shown in Fig. 5. The first part 560 and the second part 570
5 communicate via the data transmitting unit 546 and the data receiving unit 552. As previously mentioned, the data transmitting unit 546 and the data receiving unit 552 may communicate through wireless connection or wired connection. In other words, in terms of hardware configuration and data transmission, in one embodiment of the present invention, the nine-axis motion sensor module 502 comprising the rotation
10 sensor 542, the accelerometer 544 and the magnetometer 545 may be disposed distally from the processing unit or computing processor 554; the signals from the nine-axis motion sensor module 502 may then be transmitted via the data transmitting units 546, 552 to the computing processor 554 via wired or wireless communication including for example IEEE 802.11 standards or Bluetooth™.

15

[0047] The second part 570 of the electronic device 500 according to one embodiment of the present invention comprises the data transmitting unit 552 and the processor 554. The data transmitting unit 552 of the second part 570 may be in data communication with the other data transmitting unit 546 disposed distally therefrom in
20 the first part 560 as previously mentioned. The data transmitting unit 552 in the second part 570 receives the first, second and third signal sets from the data transmitting unit 546 in the first part 560 and transmits the first, second and third signal sets to the computing processor 554. In one embodiment, the computing processor 554 performs the aforementioned calculation as well as comparison of signals. In one embodiment,

said comparison utilized by the computing processor 554 may further comprise an update program to obtain an updated state based on or from a previous state associated with said first signal set and a measured state associated with said second and third signal sets. The measured state may further include a measurement of said second and third signal sets and predicted measurements obtained based on the first signal set or based on a current state of the motion sensor module 502. The computing processor 554 is external to the housing of the 3D pointing device as depicted in Fig. 5. In one embodiment, the computing processor 554 also performs mapping by translating the resultant angles of the resulting deviation of the electronic device in the spatial pointer reference frame, preferably about each of three orthogonal coordinate axes of the spatial reference frame, to a movement pattern in a display reference frame associated with the notebook computer 580. The movement pattern may be displayed on the screen 582 of the notebook computer 580.

15 [0048] FIG. 6 is an exploded diagram showing a portable electronic device 600, such as for example a 3D pointing device, utilizing a nine-axis motion sensor module according to another embodiment of the present invention in a 3D spatial reference frame. The portable electronic device 600 may further comprises a built-in display 682; examples of the portable electronic device 600 as an explanatory embodiment of the present invention may include such as smartphone, tablet PC or navigation equipment. In other words, the abovementioned display reference frame associated with a display may need not to be external to the spatial reference frame in terms of the hardware configuration of the present invention. In one embodiment, the electronic device 600 comprises a bottom cover 620, a PCB 640, a battery pack 622, a rotation sensor 642, an

accelerometer 644, a magnetometer 645, a data transmitting unit 646, a computing processor 648, a display 682, and a top cover 610. Likewise, in one embodiment, the housing 630 may comprise the top and bottom covers 610, 620. A built-in display 682 may too be integrated on the housing 630; the nine-axis motion sensor module 602 may
5 comprise the rotation sensor 642, the accelerometer 644 and the magnetometer 645. The data transmitting unit 646 and the computing processor 648 may also be integrated as a processing and transmitting module 604 of the electronic device 600. In one embodiment of the present invention, the motion sensor module or nine-axis motion sensor module 602 of the portable electronic device 600 may refer to a MEMS type of
10 sensor. In an explanatory example, the abovementioned rotation sensor 642 of the nine-axis motion sensor module 602 may further comprise at least one resonating mass such that a movement of said at least one resonating mass along an axis of said spatial reference frame may be detected and measured by said rotation sensor using the Coriolis acceleration effect to generate said first signal set comprising angular velocities
15 ω_x , ω_y , ω_z in said spatial reference frame. It can be understood that for a three-axis rotation sensor of a MEMS type sensor, there may be positioned three resonating masses along each of X, Y and Z axes of the spatial reference frame to generate and obtain movements or displacements of the three resonating masses thereof. It can too be understood that the nine-axis motion sensor 602 of the present invention may also
20 include a three-axis accelerometer, a three-axis rotation sensor and a three-axis magnetometer in a MEMS structure.

[0049] The computing processor 648 of the processing and transmitting module 604 may too perform the mapping of resultant deviation from or in said spatial reference

frame or 3D reference frame to a display reference frame such as a 2D reference frame by translating the resultant angles of the resulting deviation of the electronic device 600 in the spatial reference frame, preferably about each of three orthogonal coordinate axes of the spatial reference frame to a movement pattern in a display reference frame associated with the electronic device 600 itself. The display 682 displays the
5 aforementioned movement pattern. The top cover 610 includes a transparent area 614 for the user to see the display 682.

[0050] FIG. 7 is an explanatory flow chart illustrating a method for obtaining and/or
10 outputting a resultant deviation including deviation angles in a spatial reference frame of an electronic device, including such as a pointing device, navigation equipment or smartphone, having movements and rotations in a 3D spatial reference frame and in dynamic environments according to an embodiment of the present invention. The method in Fig. 7 may be a program such as an algorithm or a comparison model to be
15 embedded or performed by the processing unit or computing processor 348, 554, 648 of the processing and transmitting module according to different embodiments of the present invention recited herein for illustrative purposes.

[0051] Accordingly, in one embodiment of the present invention, a method for
20 obtaining a resultant deviation including deviation angles in a spatial reference frame of an electronic device utilizing a nine-axis motion sensor module therein in dynamic environments and preferably excluding undesirable external interferences thereof is provided. As the electronic device may be subject to movements and rotations in the dynamic environments, undesirable interferences may cause the measurements,
25 calculations or outputs of the motion sensor module thereof to be errorsome. In one

embodiment, said method may comprise the following steps. First of all, as shown in FIG.7, different states including “previous state”, “current state”, “measured state” and “update state” of the nine-axis motion sensor module may be provided to represent a step or a set of steps utilized by the method for obtaining the resulting deviation in 3D reference frame, and preferably in the abovementioned “absolute” manner. In one exemplary embodiment, the method comprises the steps of obtaining a previous state of the nine-axis motion sensor module (such as steps 705, 710); and wherein the previous state may too include an initial-value set predetermined to initialize said previous state of the nine-axis motion sensor module at a beginning of the method. The initial-value set may preferably be utilized at said beginning of the method or a start of the method where a previous state is not available to be obtained from an updated state (to be recited hereafter). In another embodiment where previous state may be obtained or updated from an updated state, said previous state may be a first quaternion inducing values associated with at least previous angular velocities ω_x , ω_y , ω_z gained from the motion sensor signals of the nine-axis motion sensor module at a previous time T-1. A current state of the nine-axis motion sensor module may then be subsequently obtained by obtaining measured angular velocities ω_x , ω_y , ω_z gained from the motion sensor signals of the nine-axis motion sensor module at a current time T (such as steps 715, 720). A measured state of the nine-axis motion sensor module may then be obtained by obtaining measured axial accelerations A_x , A_y , A_z gained from the motion sensor signals of the nine-axis motion sensor module at the current time T (such as step 725). Furthermore, the step of calculating predicted axial accelerations A_x' , A_y' , A_z' based on the measured angular velocities ω_x , ω_y , ω_z of the current state of the nine-axis motion sensor module (such as step 730); obtaining an updated state of the nine-axis motion

sensor module by comparing the current state with the measured state of the nine-axis motion sensor module (such as step 735); and calculating and converting the updated state of the nine-axis motion sensor module to said resulting deviation comprising said resultant angles in said spatial reference frame of the electronic device (745) may then be performed and obtained; and whereby the resultant deviation comprising deviation angles associated with the updated state of the nine-axis motion module may be obtained excluding said undesirable external interferences in the dynamic environments. In order to provide a continuous loop such as performed in a looped manner, the result of the updated state of the nine-axis motion sensor module may preferably be outputted to the previous state; in one embodiment, the updated state may be a quaternion, namely third quaternion as shown in the figure, such that it may be directly outputted to the abovementioned previous state of another quaternion, namely the abovementioned first quaternion and as shown in the figure (such as step 740).

[0052] In addition, it can be understood that the abovementioned comparison utilized by the processing and transmitting module and comprising the update program may too make reference to said different states of the nine-axis motion sensor module as shown in FIGs 7 and 8. As mentioned previously, the update program may be utilized by the processor to obtain the updated state of the nine-axis motion sensor module based on the previous state associated with a first signal set in relation to the angular velocities ω_x , ω_y , ω_z and the measured state associated with said second signal set in relation to the axial accelerations A_x , A_y , A_z . The abovementioned measured state may include a measurement of said second signal set or measured A_x , A_y , A_z and a predicted measurement of A_x' , A_y' and A_z' obtained based on or calculated from the first signal set. Details of each of the abovementioned states of the nine-axis motion sensor module

and the related steps of the method for obtaining the resultant deviation of the electronic device in 3D reference frame are as follows.

[0053] Referring to FIG. 7 again, the method for obtaining a resultant deviation including resultant angles in a spatial reference frame of electronic device utilizing a nine-axis motion sensor module according to one embodiment of the present invention may begin at the obtaining of a previous state of the nine-axis motion sensor module. In one embodiment, the previous state of the nine-axis motion sensor module may preferably be in a form of a first quaternion, and the first quaternion may be preferably initialized (step 705) at a very beginning of the process or method and as part of the obtaining of the previous state thereof. In other words, according to one embodiment of the present invention, the signals of the nine-axis motion sensor are preferably to be initialized according to a predetermined value set or quaternion including such as zeros and in particular, the signal or value associated with the yaw angle in terms of a quaternion value. The four elements of the first quaternion may be initialized with predetermined initial values. Alternatively, the first quaternion may be initialized or replaced by another signal sets generated by the rotation sensor and the accelerometer at a next time frame such that the method as shown in Fig. 7 is a continuous loop between a previous time frame T-1 and a present time frame T; details on the replacement of the first quaternion at T-1 with the later outputted quaternion at T is to be provided in the later content. It can be understood that one may make reference to Euler Angles for definition on quaternion. Similarly, it can be easily comprehended that the abovementioned previous time T-1 and present time T may too be substitute by a present time T and a next time T+1 respectively and shall too fall within the scope and

spirit of the present invention.

[0054] In addition, the abovementioned dynamic environments may include undesirable external interferences to the present invention as mentioned previously. For instance, the undesirable external interferences may refer to or include undesirable axial accelerations caused by undesirable external forces other than a force of gravity and they may too include or refer to include undesirable magnetism caused by undesirable electromagnetic fields. In a preferred embodiment of the present invention, one of the technical effects of the perform of the method as shown in FIG. 7 include that the abovementioned updated state of the nine-axis motion sensor module to said resulting deviation comprising said resultant angles in said spatial reference frame of the electronic device (step 745) may be preferably obtained excluding undesirable interferences in the dynamic environments, such as decoupling of undesirable external forces from the force of gravity to exclude undesirable axial accelerations and exclusion of undesirable external magnetism caused or induced by undesirable electromagnetic fields in the dynamic environments.

[0055] The method illustrated in Fig. 7 may be performed in consecutive time frames. According to one embodiment of the present invention, steps 710-745 may be performed in a looped manner by such as a data processing unit of an electronic device of the present invention. In another embodiment, multiple steps may be performed simultaneously, such as the obtaining of signals from the nine-axis motion sensor module may be performed simultaneously instead of one after another. It can therefore be understood that the steps recited herein are for illustrative purposes only and any

other sequential orders or simultaneous steps are possible and shall too be considered to be within the scope of the present invention. The first quaternion with respect to the previous time T is obtained as shown in the figure as step 710. When step 710 is performed, the first quaternion initialized in step 705 is obtained. Otherwise, the first quaternion used in the present time T is generated in the previous time T-1. In other words, the step 710 may generally refer to or represented by the abovementioned “previous state” of the nine-axis motion sensor module; according to another embodiment, the previous state may refer to the steps of 705 and 710.

10 **[0056]** The next may be to obtain the first signal set generated by the rotation sensor, which includes the measured angular velocities ω_x , ω_y and ω_z as shown in step 715 according to an exemplary embodiment of the present invention. In step 720, the second quaternion with respect to a present time T is calculated and obtained based on the angular velocities ω_x , ω_y and ω_z . The step 715 and 720 may generally refer to or may be represented by the abovementioned “current state” of the nine-axis motion sensor module. In one embodiment, the computing processor may use a data conversion utility including such as an algorithm to convert the angular velocities ω_x , ω_y , ω_z and first quaternion into the second quaternion. This data conversion utility may be a program or instruction represented by the following equation (1).

20
$$\begin{bmatrix} \dot{q}_0 \\ \dot{q}_1 \\ \dot{q}_2 \\ \dot{q}_3 \end{bmatrix} = \frac{1}{2} \begin{bmatrix} 0 & -\omega_x & -\omega_y & -\omega_z \\ \omega_x & 0 & \omega_z & -\omega_y \\ \omega_y & -\omega_z & 0 & \omega_x \\ \omega_z & \omega_y & -\omega_x & 0 \end{bmatrix} \begin{bmatrix} q_0 \\ q_1 \\ q_2 \\ q_3 \end{bmatrix} \dots\dots\dots (1)$$

Equation (1) is a differential equation. The quaternion on the left side of the equal sign is the first order derivative with respect to time of the quaternion (q_0, q_1, q_2, q_3) on the

right side of the equal sign. The data conversion utility uses the first quaternion as the initial values for the differential equation (1) and calculates the solution of the differential equation (1). The second quaternion may be represented by a solution of the differential equation (1).

5

[0057] As shown in the figure, the “measured state” of the nine-axis motion sensor module according to one embodiment of the present invention may generally refer or may be represented by steps 725 and 730. In step 725, the second signal set generated by the accelerometer may be obtained, which includes measured axial accelerations Ax, Ay and Az; or Ax, Ay and Az may refer to the measurement of the axial accelerations obtained. In order to obtain said measured state of the nine-axis motion sensor of the present invention, according to one embodiment, predicted axial accelerations Ax', Ay' and Az' may too be calculated and obtained based on the abovementioned current state of the nine-axis motion sensor module or the second quaternion as shown in step 730. In other words, two sets of axial accelerations may be obtained for the measured state of the nine-axis motion sensor module; one may be the measured axial accelerations Ax, Ay, Az in step 725 and the other may be the predicted axial accelerations Ax', Ay', Az' in step 730 calculated based on the abovementioned current state or second quaternion in relation to the measured angular velocities thereof. Furthermore, in one embodiment, the computing processor may use a data conversion utility to convert quaternion into the predicted axial accelerations Ax', Ay' and Az'. This data conversion utility may be a software program represented by the following equations (2), (3) and (4).

$$2(q_1q_3 - q_0q_2) = Ax' \dots\dots\dots (2)$$

$$2(q_2q_3 + q_0q_1) = Ay' \dots\dots\dots (3)$$

$$q_0^2 - q_1^2 - q_2^2 + q_3^2 = Az' \dots\dots\dots (4)$$

The computing processor calculates the solution (Ax', Ay', Az') of the equations (2), (3) and (4).

5 [0058] According to an exemplary embodiment of the method for obtaining a resultant deviation including deviation angles in a spatial reference frame of an electronic device, including such as a 3D pointing device, a portable electronic device, a navigation equipment or a smartphone, utilizing a nine-axis motion sensor module, it may be preferable to compare the current state of the nine-axis motion sensor module
10 with the measured state thereof with respect to the present time frame T by utilizing a comparison model. In other words, in one embodiment as shown in step 735, it is preferable to compare the second quaternion in relation to the measured angular velocities of the current state at present time T with the measured axial accelerations Ax, Ay, Az as well as the predicted axial accelerations Ax', Ay', Az' also at present time T.
15 Following which, a result may be advantageously obtained as an updated state of the nine-axis motion sensor module, excluding the abovementioned undesirable external interferences of the dynamic environments. In an explanatory example, the updated state may generally refer to the update of the current state of the nine-axis motion sensor module at preset time T. Instructions including equations related to the abovementioned
20 current state, measured state and updated state may be illustrated in the following.

[0059] According to an exemplary embodiment of the comparison model utilized by the present invention in relation to step 735 as shown in the figure, the current state correlated to the abovementioned second quaternion and in relation to the angular

velocities of gyroscope(s) may be obtained based on an exemplary equation of:

$$x(t | t - 1) = f(x_{t-1}, u_t) \dots\dots\dots (5)$$

Preferably, a first probability (state transition probability) associated with the said current state may be further obtained based on an exemplary equation of:

5
$$P(x_t | x_{t-1}, u_t) = F_x P(x_{t-1} | x_{t-1}) F_x^T + F_u P(u_{t-1} | u_{t-1}) F_u^T + Q_t$$

$$F_x = \frac{\partial f(x_{t-1}, u_t)}{\partial x_{t-1}} \dots\dots\dots (6)$$

$$F_u = \frac{\partial f(x_{t-1}, u_t)}{\partial u_t} \dots\dots\dots (7)$$

wherein Q_t = additional motion model noise

10 Likewise, the measured state correlated to the abovementioned predicted axial accelerations and in relation to the axial accelerations of accelerometers and current state may be obtained based on an exemplary equation of:

$$z_t(t | t - 1) = h(x(t | t - 1)) \dots\dots\dots (8)$$

Preferably, a second probability (measurement probability) associated with the measured state may be further obtained based on an exemplary equation of:

15
$$P(z_t | x_t) = H_x P(x_t | x_{t-1}) H_x^T + R_t \dots\dots\dots (9)$$

$$H_x = \frac{\partial h(x(t | t - 1))}{\partial x(t | t - 1)} \dots\dots\dots (10)$$

wherein R_t = measurement model noise

20 As an illustrative example, the abovementioned first and second probabilities may be further utilized to obtain the updated state of the nine-axis motion sensor module based on an exemplary method of data association of an exemplary equation of:

$$D_t = \{ [z_t - h(x(t | t - 1))] P(z_t | x_t) [z_t - h(x(t | t - 1))]^{-1} \}^{1/2} \dots\dots\dots (11)$$

In one embodiment, the result of the updated state of the nine-axis motion sensor module, preferably involving comparison or data association represented by the equations, may be a third quaternion as shown in the figure. Furthermore, the result may then be further outputted and utilized to obtain a resultant deviation, excluding
5 undesirable interferences of the dynamic environments under which the present invention is subject to, but including deviation angles in a spatial reference frame in the following steps as shown in the figure. In a preferred embodiment of the present invention, said undesirable external interferences may further comprise or refer to undesirable axial accelerations caused by undesirable external forces other than a force
10 of gravity; in another preferred embodiment, said undesirable external interferences may further comprise or refer to undesirable magnetism caused by undesirable electromagnetic fields. In other words, the method and algorithm provided by the present invention may preferably generate or provide an output of the resultant deviation of the nine-axis motion sensor module excluding the abovementioned
15 undesirable interferences. In one example, external forces exerted to cause axial accelerations of a nine-axis motion sensor of an electronic device of the present invention may be decoupled or separated from a force of gravity; and in another example, the undesirable magnetism caused by such as electromagnetic fields external or internal to an electronic device the present invention may be excluded. It can be
20 understood that the examples of current state, measured state, state update, data association and probabilities of the comparison model and method of the present invention recited herein are provided for illustrative purposes only.

[0060] As mentioned previously, it may be preferable to output the result of the

updated state, preferably in a form of third quaternion, to the previous state of the nine-axis motion sensor module as shown in step 740 in FIG.7. In a preferred embodiment, the updated state may further comprise a first data association model; and wherein the abovementioned and related data association model may be provided for
5 comparing the measured state associated with said second signal set with a predicted measurement obtained from said current state. In other words, in one embodiment, the first quaternion may be replaced by the abovementioned third quaternion or substitute directly any previous values of first quaternion in the previous time T for further process in a loop. In other words, the third quaternion with respect to the present time T
10 becomes the first quaternion with respect to the next time such as T+1; or, the third quaternion at previous time frame T-1 outputted may now be the first quaternion at present time frame T.

[0061] In step 745, the updated state of the nine-axis motion sensor module of the
15 present invention may be further calculated and converted to the resultant deviation including deviation angles associated with the spatial reference frame, wherein the deviation angles includes the yaw angle, pitch angle and roll angle of the electronic device associated with the spatial reference frame, preferably about each of three orthogonal coordinate axes of the spatial reference frame; and whereby the resultant
20 deviation comprising deviation angles associated with the updated state of the nine-axis motion module may be preferably obtained excluding said undesirable external interferences in the dynamic environments. In an explanatory example, said undesirable external interferences may refer to or further comprise undesirable axial accelerations caused by undesirable external forces other than a force of gravity. In

another explanatory example, said undesirable external interferences may refer to or further comprise undesirable magnetism caused by undesirable electromagnetic fields. In one embodiment, the computing processor may use a data conversion utility to convert the third quaternion of the updated state of the nine-axis motion sensor module into the yaw, pitch and roll angles thereof. This data conversion utility may be a program or instruction represented by the following equations (12), (13) and (14).

$$yaw = \arctan\left(\frac{2(q_0q_3 + q_1q_2)}{q_0^2 + q_1^2 - q_2^2 - q_3^2}\right) \dots\dots\dots (12)$$

$$pitch = \arcsin(2(q_0q_2 - q_3q_1)) \dots\dots\dots (13)$$

$$roll = \arctan\left(\frac{2(q_0q_1 + q_2q_3)}{q_0^2 - q_1^2 - q_2^2 + q_3^2}\right) \dots\dots\dots (14)$$

10 The variables q_0 , q_1 , q_2 and q_3 in equations (12), (13) and (14) are the four elements of the third quaternion.

[0062] For a looped method continuous with respect to time, in one embodiment of the present invention, the method utilized by for example the computing processor communicated with the nine-axis motion sensor module may return to step 710 to perform the comparison process or method with respect to the next time $T+1$. In addition, the abovementioned resultant deviation including deviation angles comprising yaw, pitch and roll angles in the spatial reference frame converted from the third quaternion is preferably obtained and outputted in an absolute manner reflecting or associating with the actual movements and rotations of the electronic device of the present invention in said spatial reference frame. It can be understood that said actual movements and rotations of the electronic device of the present invention in the spatial

reference frame or 3D reference frame may refer to real-time movements and rotations associated with vectors having both magnitudes and directions along or about orthogonal axes in the spatial reference frame under the dynamic environments.

5 [0063] FIG. 8 shows a flow chart illustrating a method of mapping resultant deviation angles of an electronic device having movements and rotations in a 3D spatial reference frame and in a dynamic environment onto a display reference frame according to another embodiment of the present invention. FIG. 9 is a schematic diagram showing the aforementioned mapping of the resultant angles of the resultant deviation of an
10 electronic device according to this embodiment. For illustrative purposes, the difference between FIG. 7 and Fig. 8 may be represented by the additional mapping step 750 as shown in FIG. 8. Steps 705-745 in Fig. 8 are the same as their counterparts in Fig. 7, which perform the comparison process for the 3D pointing device. Step 750 performs the mapping process for the electronic device. The computing processor may include a
15 mapping program that performs the mapping step 750. At step 750, the processing and transmitting module may obtain display data including for example, display screen size such as boundary information, and translates the deviation angles of the resultant deviation associated with the spatial reference frame, preferably about each of three orthogonal coordinate axes of the spatial reference frame, to a movement pattern in a
20 mapping area in a display reference frame based on a sensitivity input correlated to the display reference frame. It can be understood that the abovementioned display data may too include or refer to the type of display such as LED, LCD, touch panel or 3D display as well as frequency rate of display such as 120Hz or 240Hz. In one embodiment, the display reference frame associated with the display to be mapped may be a 2D display

reference frame; in another embodiment, the display reference frame may be a 3D display reference frame of a 3D display.

[0064] The aforementioned display data may further include a sensitivity input.

5 The aforementioned sensitivity input is a parameter which may be inputted and adjusted by a user through control buttons attached on the housing of the electronic device. The sensitivity input may represent the sensitivity of the display device with respect to the movement of the electronic device. For details of the mapping process, please refer to Fig. 9. In one embodiment, the sensitivity input is a parameter representing the
10 relationship between the display to be mapped with deviation to a movement pattern in 2D display reference frame and the electronic device of the present invention outputted with said deviation including yaw, pitch and roll angles in 3D reference frame; wherein the relationship may be a distance relationship. In another embodiment, the sensitivity input may be a display screen size including boundary information predetermined by a
15 user; wherein the boundary information may be obtained based on a user input or manual input data from the user. In still another embodiment, the sensitivity input may be predefined or preset in the mapping program such that the parameter of the sensitivity input is a preset value for either increase or decrease the movement patterns including distance or number of pixels to be moved or mapped from said resultant
20 deviation of the electronic device of the present invention.

[0065] Fig. 9 is a bird's-eye view of an electronic device 930 according to one embodiment of the present invention directed to a display screen 910 of a display device. The display screen has a central point 922, a target point 924 and a boundary point 926.

The central point 922 is the geometric center of the display screen 910. The target point 924 is the position that the electronic device 930 is aiming at. The boundary point 926 is a point on the right boundary of the display screen 910. The points 922, 924, 926 and the electronic device 930 are on a common plane parallel to both the X_D axis and the Z_D axis of the display reference frame $X_D Y_D Z_D$. Virtual beams 942, 944 and 946 are imaginary light beams from the electronic device 930 to the central point 922, the target point 924 and the boundary point 926, respectively. The distance P is the distance between the central point 922 and the target point 924, while the distance P_{max} is the distance between the central point 922 and the boundary point 926. The distance d is the distance between the central point 922 and the electronic device 930. The aforementioned yaw angle of the resultant deviation of the electronic device 930 of the present invention is the angle θ between the virtual beams 942 and 944, while the angle θ_{max} is the angle between the virtual beams 942 and 946. The aforementioned mapping area is a plane including the display surface of the display screen 910 in the display reference frame. The display surface of the display screen 910 is a subset of the mapping area.

[0066] In this embodiment, the aforementioned sensitivity input is provided by the user of the electronic device 930. The sensitivity β is defined by the following equation (15).

$$\beta = \frac{P_{max}}{\theta_{max}} \dots\dots\dots (15)$$

The variable β in equation (16) is the sensitivity input defined by user.

The following equation (16) may be derived from equation (15) and geometry.

$$d = \frac{P_{\max}}{\tan\left(\frac{P_{\max}}{\beta}\right)} \dots\dots\dots(16)$$

The following equation (17) may be derived from equations (16).

$$P = f(\theta) = d \times \tan \theta = \frac{P_{\max} \times \tan \theta}{\tan\left(\frac{P_{\max}}{\beta}\right)} \dots\dots\dots(17)$$

5 **[0067]** In equation (17), the distance P_{\max} may be obtained from the width of the display screen of the display data obtained at step 750; the angle θ is the yaw angle obtained at step 745; the sensitivity input β is provided by the user. Therefore, the computing processor of the electronic device 930 can calculate the distance P according to equation (17). Next, the computing processor can easily obtain the horizontal coordinate of the target point 924 on the display screen 910 according to the distance P
 10 and the width of the display screen 910. In addition, the computing processor can easily obtains the vertical coordinate of the target point 924 on the display screen 910 according to the pitch angle in a similar way.

15 **[0068]** The mapping process performed at step 750 may be exemplified by the process of translating the yaw angle and the pitch angle of the resultant angles to the 2D coordinates of the target point 924 on the display screen 910 discussed above. Now the computing processor has the coordinates of the target point 924 of the present time frame. The computing processor subtracts the coordinates of the target point 924 of the
 20 previous time frame from the coordinates of the target point 924 of the present time frame. The result of the subtraction is the horizontal offset and the vertical offset of the target point 924 in the present time frame. The horizontal and vertical offsets may be

transmitted to the display device so that the display device can track the position of the target point 924. The display device may display a cursor or some video effect on the display screen 910 to highlight the position of the target point 924. The cursor or video effect may exhibit a movement pattern on the display screen 910 when the user moves
5 the electronic device 930 of the present invention.

[0069] Likewise, according to another embodiment of the present invention, the comparison method of the present invention may be a looped method. For a looped method continuous with respect to time, in one embodiment, the method utilized by for
10 example the computing processor communicating with the nine-axis motion sensor module may return to step 710 to perform the comparison process or method with respect to the next time $T+1$, following which the comparison and mapping process with respect to the next time frame may then be performed.

[0070] FIG. 10 shows another embodiment of the comparison method of the present invention. The flow chart illustrates a method of obtaining resultant deviation including deviation angles in a spatial reference frame of an electronic device utilizing a nine-axis motion sensor module therein and subject to movements and rotations in dynamic environments in the spatial reference frame and mapping resultant deviation of the
15 electronic device of the present invention having movements and rotations in a 3D spatial reference frame and in a dynamic environment onto a display reference frame according to another embodiment of the present invention; and whereby the resultant deviation comprising deviation angles associated an output or state such as an updated
20 state (details below) of the nine-axis motion module may be preferably obtained

excluding said undesirable external interferences in the dynamic environments. In an explanatory example, said undesirable external interferences may refer to or further comprise undesirable axial accelerations caused by undesirable external forces other than a force of gravity. In another explanatory example, said undesirable external interferences may refer to or further comprise undesirable magnetism caused by undesirable electromagnetic fields. The steps 1005-1030 in Fig. 10 may make reference to the ones shown in another embodiment of the present invention as shown in Fig. 7.

[0071] For an electronic device, including such as a pointing device, a navigation equipment, a smartphone or other portable electronic apparatus, utilizing a nine-axis motion sensor module, the signals of the magnetometer of the motion sensor module may be preferably be used to facilitate the obtaining of the resultant deviation including deviation angles in 3D reference and preferably in an absolute manner. The third signal set generated by the magnetometer may be obtained as shown in step 1035 in FIG. 10, which includes measured magnetism M_x , M_y and M_z . In one embodiment, the M_x , M_y and M_z may refer to the measurement of the magnetism obtained. In order to obtain said measured state of the nine-axis motion sensor, according to one embodiment of the present invention, predicted magnetism M_x' , M_y' and M_z' may too be calculated and obtained based on the abovementioned current state of the nine-axis motion sensor module or the second quaternion as shown in step 1040. In other words, two sets of magnetism may be obtained for the measured state of the nine-axis motion sensor module; one may be the measured magnetism M_x , M_y , M_z in step 1035 and the other may be the predicted magnetism M_x' , M_y' , M_z' in step 1040 calculated based on the abovementioned current state or second quaternion in relation to the measured angular

velocities thereof. Furthermore, in one embodiment, the computing processor may use a data conversion utility to convert the current state or second quaternion into predicted magnetism Mx' , My' and Mz' and vice versa. This data conversion utility may be a software program represented by the following equations (18), (19) and (20).

5 $(q_0^2 + q_1^2 - q_2^2 - q_3^2) \cos \lambda + 2(q_1q_3 - q_0q_2) \sin \lambda = Mx' \dots\dots\dots (18)$

$2(q_1q_2 - q_0q_3) \cos \lambda + 2(q_2q_3 + q_0q_1) \sin \lambda = My' \dots\dots\dots (19)$

$2(q_1q_3 + q_0q_2) \cos \lambda + (q_0^2 - q_1^2 - q_2^2 + q_3^2) \sin \lambda = Mz' \dots\dots\dots (20)$

The variable λ in equations (18), (19) and (20) is the dip angle between the direction of the ambient magnetic field measured by the magnetometer and a horizontal plane in the spatial reference frame. The dip angle λ may be measured or calculated through an initial calibration process of the electronic device of the present invention and then be used as a parameter. The computing processor calculates the solution (Mx' , My' , Mz') of the equations (18), (19) and (20).

15 **[0072]** According to an exemplary embodiment of the method for obtaining a resultant deviation including deviation angles in a spatial reference frame of an electronic device, including such as a pointing device, a navigation equipment, a smartphone or other portable electronic apparatus, utilizing a nine-axis motion sensor module, it may be preferable to compare the current state of the nine-axis motion sensor module with the measured state thereof with respect to the present time frame T by utilizing a comparison model. In other words, in one embodiment as shown in step 1045, it is preferable to compare the second quaternion in relation to the measured angular velocities of the current state at present time T with the measured axial accelerations Ax , Ay , Az , the predicted axial accelerations Ax' , Ay' , Az' , the measured magnetism Mx ,

20

My, Mz, and the predicted magnetism M_x' , M_y' , M_z' also at present time T. Following which, a result may be obtained as an updated state of the nine-axis motion sensor module. In general and in an explanatory example of the present invention, the updated state may generally refer to the update of the previous state of the nine-axis motion sensor module at a previous time T-1 with reference to the current state and/or measured state thereof. The comparison model in step 1045 utilizes the measured axial accelerations A_x , A_y , A_z and measured magnetism M_x , M_y , M_z , as well as the predicted axial accelerations A_x' , A_y' , A_z' and the predicted magnetism M_x' , M_y' , M_z' .

5

10

[0073] In one embodiment, the result of the updated state of the nine-axis motion sensor module, preferably involving comparison or data association represented by the equations associated to the comparison model, may be a third quaternion as shown in the figure. Furthermore, as shown in steps 1050~1060, the result may then be further outputted and utilized to obtain a resultant deviation including deviation angles in a spatial reference frame in the steps as shown in the figure. It can be understood that the examples of current state, measured state, state update, data association and probabilities of the comparison model and method of the present invention are provided for illustrative purposes only.

15

20

[0074] FIG. 11 shows a further exemplary embodiment of the comparison method of the present invention. The flow chart illustrates a method of obtaining resulting deviation including resultant angles in a spatial reference frame of an electronic device, including such as a pointing device, a navigation equipment, a smartphone or other

portable electronic device, utilizing a nine-axis motion sensor module therein and subject to movements and rotations in dynamic environments in the spatial reference frame and mapping resultant deviation angles of said electronic device having movements and rotations in the 3D spatial reference frame and in a dynamic environment onto a display reference frame according to another embodiment of the present invention. Likewise, steps 1105~1130 may include obtaining a previous state and a current state of the motion sensor module as well as a measured state related to the axial accelerations of the motion sensor module. Additionally, in step 1135, it may be preferable to compare the current state of the nine-axis motion sensor module with the measured state thereof with respect to the present time frame T by utilizing a comparison model. In other words, as shown in step 1135, it is preferable to compare the second quaternion in relation to the measured angular velocities of the current state at present time T with the measured axial accelerations A_x , A_y , A_z as well as the predicted axial accelerations A_x' , A_y' , A_z' also at present time T. Following which, a result may be obtained as the first updated state of the nine-axis motion sensor module. In an explanatory example, the first updated state may generally refer to the first update of the current state of the nine-axis motion sensor module at preset time T. Furthermore, one of the technical effects of the present invention may too be obtained or achieved. In step 1135, one of the advantages or effects by performing steps from 1105~1135 may be that the first updated state or third quaternion as shown in FIG. 11 may be advantageously obtained excluding undesirable axial accelerations caused by for example undesirable external forces such as the ones decoupled from a force of gravity.

[0075] In one embodiment, the result of the first updated state of the nine-axis

motion sensor module, preferably involving comparison or data association represented
 by the equations associated to the comparison model, may be a third quaternion as
 shown in the figure. In addition, one of the technical effects of the present invention
 may include the exclusion of undesirable external interferences in the dynamic
 5 environment as previously mentioned; and wherein the undesirable external
 interferences may refer to or further include undesirable axial accelerations caused by
 undesirable external forces, preferably decoupled from a force of gravity, and/or
 undesirable magnetism caused by for example undesirable electromagnetic fields either
 adjacent to the motion sensor module. As shown in step 1140 of FIG. 11, the first
 10 updated state of the nine-axis motion sensor module of the present invention may be
 further calculated and converted to a temporary pitch angle and a temporary roll angle
 based on the third quaternion. The first updated state, as shown in the figure, may be
 advantageously obtained such that or whereby undesirable axial accelerations associated
 with said undesirable external interferences in the dynamic environments may be
 15 preferably excluded; in an explanatory example, the first updated state may be
 preferably obtained excluding the abovementioned undesirable axial accelerations
 caused by undesirable external forces, such as external forces decoupled from a force of
 gravity. The third signal set generated by the magnetometer may be obtained, which
 includes measured magnetism M_x , M_y and M_z . The measured state of the nine-axis
 20 motion sensor module may be obtained by obtaining and calculating a measured yaw
 angle gained from the motion sensor signals of the nine-axis motion sensor module at
 the current time T according to the following equation (21).

$$T_y = \frac{-M_y \cos(Tr) + M_z \sin(Tr)}{M_x \cos(Tp) + M_y \sin(Tp) \cos(Tr) + M_z \sin(Tp) \cos(Tr)} \dots\dots\dots (21)$$

In equation (21), T_y is the measured yaw angle, T_p is the temporary pitch angle and T_r

is the temporary roll angle.

[0076] In order to obtain said measured state of the nine-axis motion sensor, according to one embodiment of the present invention, a predicted yaw angle may be calculated and obtained based on the abovementioned first updated state of the nine-axis motion sensor module or the third quaternion at present time T as shown in step 1145. In other words, the measured yaw angle in step 1140 and the predicted yaw angle in step 1145 may be obtained for the measured state of the nine-axis motion sensor module.

[0077] Furthermore, it may be preferable to compare the current state of the nine-axis motion sensor module with the measured state thereof with respect to the present time frame T by utilizing a comparison model. In other words, as shown in step 1150, it is preferable to compare the second quaternion in relation to the measured angular velocities of the current state at present time T with the measured axial accelerations A_x , A_y , A_z , the predicted axial accelerations A_x' , A_y' , A_z' , the measured yaw angle and the predicted yaw angle also at present time T. Following which, a result may be obtained as the second updated state of the nine-axis motion sensor module. In an explanatory example, the second updated state may generally refer to the second update of the current state of the nine-axis motion sensor module at preset time T. The comparison model in step 1150 is very similar to the abovementioned comparison models. Related details are omitted here for brevity. In one embodiment, the result of the second updated state of the nine-axis motion sensor module may be a fourth quaternion as shown in the figure. Furthermore, the result may then be further outputted and utilized to obtain a

resulting deviation including resultant angles in a spatial reference frame in the following steps as shown in the figure. In addition to the abovementioned technical effects of the present invention in which undesirable axial accelerations of undesirable external interferences in the dynamic environments may be advantageously excluded as a result of the first updated state of the motion sensor module in step 1135, another technical effect or merit may too be obtained along with result of the second updated state of the motion sensor as shown in step 1150 of FIG. 11. One of the advantages or effects by performing steps such as from 1140~1150 may be that the second updated state or fourth quaternion as shown in FIG. 11 may be advantageously obtained excluding undesirable magnetism such as the ones caused by for example undesirable external or internal electromagnetic fields adjacent to the motion sensor module in the dynamic environments of the present invention.

[0078] It may be preferable to output the result of the second updated state, preferably in a form of the fourth quaternion, to the previous state of the nine-axis motion sensor module as shown in step 1155 in the figure. In other words, in one embodiment, the first quaternion may be replaced by the abovementioned fourth quaternion or substitute directly any previous values of first quaternion in the previous time T for further process in a loop. In other words, the fourth quaternion with respect to the present time T becomes the first quaternion with respect to the next time such as T+1; or, the fourth quaternion at previous time frame T-1 outputted may now be the first quaternion at present time frame T.

[0079] In step 1160, the second updated state of the nine-axis motion sensor module

of the present invention may be further calculated and converted to the resulting deviation including resultant angles associated with the spatial reference frame, wherein the resultant angles includes the yaw angle, pitch angle and roll angle of the 3D pointing device associated with the spatial reference frame, preferably about each of three
5 orthogonal coordinate axes of the spatial reference frame. In addition, the second updated state, as shown in the figure, may be advantageously obtained such that or whereby undesirable magnetism associated with said undesirable external interferences in the dynamic environments may be preferably excluded; in an explanatory example, the second updated state may be preferably obtained excluding the abovementioned
10 undesirable magnetism caused by for example undesirable electromagnetic fields, or magnetism other than the planetary geomagnetism, adjacent or of a magnitude influencing magnetometer of the motion sensor module. The resultant angles may be calculated according to equations (12), (13) and (14), wherein the variables q_0 , q_1 , q_2 and q_3 in equations (12), (13) and (14) are the four elements of the fourth quaternion.
15 Furthermore, the resultant deviation in step 1160 may be advantageously obtained excluding undesirable interferences including such as the ones of undesirable axial accelerations caused by undesirable external forces decoupled from a force of gravity mentioned previously in step 1135 and the ones of undesirable magnetism caused by for example undesirable electromagnetic fields as mentioned previously in step 1150.
20 Likewise, in step 1165 as shown in FIG. 11, the resultant deviation including deviation angles in 3D pointer reference may be further mapped to a display reference such as a 2D display reference of a display.

[0080] As illustrated by FIG.12, in one preferred embodiment, the first and second
25 updated states may further comprise a first data association model and a second data

association model respectively. The first data association model may be advantageously provided for comparing the first measured state associated with said second signal set with a first predicted measurement obtained from said current state; in addition, the second data association model may too be advantageously provided for comparing the second measured state associated with said third signal set with a second predicted measurement obtained from said first updated state. Furthermore, in another preferred embodiment, the first and second updated states may further comprise a first data association model and a second data association model respectively; and wherein the first data association model may be advantageously provided for comparing the first measured state associated with said second signal set with a first predicted measurement obtained from said current state; and wherein the second data association model may be advantageously provided for comparing the second measured state associated with said third signal set with a second predicted measurement obtained from said current state. Details on the differences of the obtaining of said second predicted measurement based on either the first updated state or the current state of the motion sensor module depending upon a comparison result are further described in FIG. 12, as the routes presented or denoted by “Yes” and “No” shown therein.

[0081] FIG. 12 shows an exemplary flow chart of another embodiment of the present invention of a method for obtaining a resultant deviation comprising deviation angles of an electronic device, including such as a pointing device, navigation equipment, a smartphone or other portable electronic apparatus. Accordingly, the method for obtaining a resultant deviation including deviation angles in a spatial reference frame of an electronic device utilizing a nine-axis motion sensor module therein and subject to movements and rotations in dynamic environments in said spatial reference frame

includes the following steps. As shown in the figure, at step 1210, a previous state of the nine-axis motion sensor module may be obtained; and wherein the previous state is associated with at least previous angular velocities gained from the motion sensor signals of the nine-axis motion sensor module at a previous time T-1. In another embodiment, the previous state is associated with previous angular velocities, previous axial accelerations and previous magnetism gained from the motion sensor signals of the nine-axis motion sensor module at a previous time T-1. Next, at step 1220, it may be to obtain a current state of the nine-axis motion sensor module by obtaining measured angular velocities ω_x , ω_y , ω_z gained from the motion sensor signals of the nine-axis motion sensor module at a current time T. At step 1225, it may be to obtain a first measured state of the nine-axis motion sensor module by obtaining measured axial accelerations A_x , A_y , A_z gained from the motion sensor signals of the nine-axis motion sensor module at the current time T. Following which and at step 1230 is calculating and obtaining a first predicted measurement of the nine-axis motion sensor module based on said current state thereof. At step 1235, a comparison may be performed to determine whether the signals related to the measured state including such as measured axial accelerations and/or measured magnetism are “good enough” to be used to compensate the current state of the motion sensor module and therefore an updated state thereof can be obtained.

20

[0082] According to the previously mentioned objectives of the present invention, it is preferable to provide an advantageous comparison or compensation method capable of outputting resultant deviation of a motion sensor module of a relatively high accuracy in the presence of external or internal interferences including such as electromagnetic

fields generated by other electronic components adjacent to the motion sensor modules or of a magnitude strong enough to distort or affect the normal operations or signals of motion sensor module. Under such circumstances, a comparison utilizing data association may be advantageously provided or used to compare measured state of the motion sensor modules with an expected or predicted measurement thereof to determine the compensation for updating an updated state of the previous state. In step 1235 as previously mentioned, the data association may also include a predetermined value preset or preselected in accordance with for example the performance of motion sensor module utilized, and such that the comparison result of the measured state and the predicted measurement may make reference to the data association and the predetermined value or range to determine the compensation needed to take place to update the state of the motion sensor module including such as the previous and/or current states thereof.

[0083] Accordingly, updated state(s) of the motion sensor module may be obtained based on the result of the data association(s). As shown in the figure, if the result of abovementioned comparison falls within the predetermined result of for example a predetermined value or range of the data association, then in one embodiment of the present invention, in step 1240, a first updated state of the nine-axis motion sensor module may be obtained based on a first comparison between said first predicted measurement and said first measured state of the nine-axis motion sensor module. Otherwise, if the result is not within the predetermined value of range of the data association, then the first updated state may not be performed or obtained. Such method of the use of data association and comparison may be particularly useful in the

abovementioned scenario of external or internal “interferences” such as the ones caused by undesired electromagnetic fields. In the case where the result falls outside of expected range, or denoted by “No” as shown in FIG. 12, the next step would be to obtain another measured state or the second measured state of the motion sensor module to determine whether another data association may be utilized to obtain the second updated state. It can however be understood that the second updated state may be provided as an additional step to the method of the present invention. One may only perform the abovementioned steps and obtain a result of the first updated state based on the measured state including the measured axial accelerations associated with the motion sensor module; in other words, either performing steps to obtain only the first updated state, steps to obtain only the second updated state, and/or steps to obtain both the first and second updated states as shown in the figure, shall all be considered to be within the scope of the present invention and within the spirit of the present invention. Furthermore and likewise, one of the technical effects of the present invention may too be obtained or achieved. In step 1240, one of the advantages or effects by performing steps from 1210~1240 may be that the first updated state as shown in FIG. 12 may be advantageously obtained excluding undesirable axial accelerations caused by for example undesirable external forces such as the ones decoupled from a force of gravity.

[0084] In another embodiment of the present invention or in the case where the abovementioned second updated state is to be obtained, one may further perform steps 1245 ~1260 as shown in FIG. 12. In step 1245, one may obtain a second measured state of the nine-axis motion sensor module by obtaining a measured yaw angle based on measured magnetism M_x , M_y , M_z gained from the motion sensor signals of the

nine-axis motion sensor module at the current time T. Furthermore, as shown in step 1250, a second predicted measurement of the nine-axis motion sensor module may be calculated and obtained, following which a predicted yaw angle may too be obtained based on said first updated state thereof depending upon the result of the comparison such as the route denoted by “Yes” in FIG. 12. In another embodiment, the predicted yaw angle may be obtained based on said current state of the motion sensor module depending upon the result of the comparison such as a result or route of “No” denoted in FIG. 12. Once the measured state and the predicted measurements are obtained and available, a second comparison may be performed to determine whether compensation may be carried out based on the result of the comparison and the second data association. As shown in step 1255, the second data association including a predetermined value or range may be performed to determine whether the comparison falls within said predetermined value or range. If the result falls within said value or range, then a second updated state may be obtained and compensation may too take place as shown in step 1260 with the denotation of “Yes”. Otherwise, if the result is not within the predetermined value, then step 1265 shall be carried out, following the direction shown and denoted by “No” in the figure; and in other words, compensation may utilize the second predicted measurement of the motion sensor module thereof for updating instead of using the second measured state thereof. Likewise, in addition to the abovementioned technical effects of the present invention in which undesirable axial accelerations of undesirable external interferences in the dynamic environments may be advantageously excluded as a result of the first updated state of the motion sensor module in step 1240, another technical effect or merit may too be obtained along with result of the second updated state of the motion sensor as shown in step 1260 of FIG. 12.

One of the advantages or effects by performing steps such as from 1245~1260 may be that the second updated state as shown in FIG. 12 may be advantageously obtained excluding undesirable magnetism such as the ones caused by for example undesirable external or internal electromagnetic fields adjacent to the motion sensor module in the dynamic environments of the present invention.

[0085] Following the above steps, in one embodiment of the present invention in which said comparison method may be provided in a continuous loop or a looped manner with respect to time, the result of the updated state at present time T may then be outputted to the previous state at previous time T-1 and become another beginning of the loop for the abovementioned steps to carry out again. The terminology of time(s) T, T-1 or T+1 shall be clear and apparent and shall too fall within the scope and spirit of the present invention. For example, in step 1260 as shown in FIG. 12, the second updated state of the nine-axis motion sensor module may be obtained by, or may too include, the updating said first updated state thereof based on a second comparison between said second predicted measurement and said second measured state of the nine-axis motion sensor module; and in step 1265, the result of the second updated state thereof may be further outputted to the previous state in a looped manner with respect to time.

[0086] After step 1265, the resultant deviation including the deviation angles in the spatial reference frame, namely the yaw, pitch and roll angles, may be obtained in step 1270 in a similar way as those in steps 745, 1060 and 1160. Furthermore, the resultant deviation in step 1270 may be advantageously obtained excluding undesirable

interferences including such as the ones of undesirable axial accelerations caused by undesirable external forces decoupled from a force of gravity mentioned previously in step 1240 and the ones of undesirable magnetism caused by for example undesirable electromagnetic fields as mentioned previously in step 1260.

5

[0087] As mentioned previously, in one embodiment of the present invention, the method for obtaining a resultant deviation of an electronic device utilizing a nine-axis motion sensor module, data associations may be provided to obtain a relatively accurate result under for example the existence of external or internal interferences to the sensor module. Accordingly, the abovementioned step of obtaining the first updated state of the nine-axis motion sensor module may further comprise performing a first data association to determine whether said first comparison between said first predicted measurement and said first measured state thereof falls within a first predetermined value of the nine-axis motion sensor module; and wherein the step of obtaining the second updated state of the nine-axis motion sensor module may too further comprise performing a second data association to determine whether said second comparison between said second predicted measurement and said second measured state thereof falls within a second predetermined value of the nine-axis motion sensor module.

10
15
20
25
[0088] Likewise, in accordance to the abovementioned continuous loop of the method of the present invention with respect to time and in one embodiment, the method for obtaining a resultant deviation of an electronic device utilizing a nine-axis motion sensor module may further comprise outputting said second updated state of the nine-axis motion sensor module to said previous state thereof; and wherein said previous state of the nine-axis motion sensor module may be a first quaternion with

respect to said previous time T-1; and wherein said current state of the nine-axis motion sensor module may be a second quaternion with respect to said current time T; and wherein said first and second updated states of the nine-axis motion sensor module may too be a third and a fourth quaternion with respect to said current time T respectively.

5

[0089] In summary, the present invention also provides a nine-axis comparison method that compares the detected signals generated by and converted from the rotation of the electronic device, utilizing a nine-axis motion sensor module, about all of the three axes with the detected signals generated by and converted from the acceleration of the device along all of the three axes. In one embodiment, the nine-axis comparison method may then output the resultant deviation including yaw, pitch and roll angles in a spatial reference frame such as a 3D reference frame of the device. In another embodiment, the nine-axis comparison method may also include the mapping of the resultant deviation including yaw, pitch and roll angles in the spatial reference to a display reference frame such as a 2D display reference frame of a display screen of a display device. The nine-axis comparison method involving the comparison of different states of the motion sensor module and the utilization of data association of the present invention in order to output a resultant deviation having yaw, pitch and roll angles in for example 3D reference frame is novel and cannot be easily achieved by any know arts or their combinations thereof.

10

15

20

[0090] In view of the above, it is clear that such obtaining and outputting of deviation including 3D angles in a spatial reference frame in an “absolute” manner of the present invention is too novel, and the fact that the electronic device utilizing a

5 motion sensor module therein having a novel comparison method and program of the present invention to obtain and output such deviation in “absolute” manner cannot be easily achieved by any known arts or their combination thereof. The term “absolute” associated with the resulting deviation including resultant angles such as yaw, pitch and roll in a spatial reference frame or 3D reference frame obtained and outputted by the device of the present invention may refer to the “actual” movements and rotations of the 3D pointer device of the present invention in said spatial reference frame. Moreover, the nine-axis comparison method of the present invention may accurately output said deviation including angles in 3D reference frame as noises associated with the nine-axis motion sensor module subject to movement and rotations in dynamic environments and accumulated over time may be effectively eliminated or compensated. Furthermore, the term “a”, “an” or “one” recited herein as well as in the claims hereafter may refer to and include the meaning of “at least one” or “more than one”. It can be understood that, as previously mentioned, the term of “dynamic” recited herein may refer to moving or subject to motions in general. It too can be understood that the term “excluding” recited herein to describe the exclusion of undesirable interferences is provided for illustrative purposes and shall not be limited to a certain or specific degree or magnitude of the effect of exclusion; any degree or magnitude associated thereto shall be considered to be within the spirit and scope of the present invention.

20

[0091] FIG. 13 is a flow chart of a method for compensating rotations of a 3D pointing device according to an embodiment of the present invention. The purpose of the method is transforming rotations and movements of the 3D pointing device to a movement pattern in the display plane of a display device (such as the plane $X_D Y_D$ of

the display device 120 shown in FIG. 1 and FIG. 2). The method may be executed by the 3D pointing device shown in FIG. 14. FIG. 14 is a schematic diagram showing a 3D pointing device according to an embodiment of the present invention. The 3D pointing device in FIG. 14 includes a rotation sensor 342, an orientation sensor 1410, and a computing processor 1420. The orientation sensor 1410 includes an accelerometer 344 and another computing processor 348.

[0092] The flow in FIG. 13 is discussed as follows. In step 1320, the orientation sensor 1410 generates an orientation output associated with the orientation of the 3D pointing device associated with three coordinate axes of a global reference frame associated with the Earth. The computing processor 348 of the orientation sensor 1410 may generate the aforementioned orientation output by executing steps 710 to 745 illustrated in FIG. 7 and FIG. 8. In brief, in steps 710 to 745 illustrated in FIG. 7 and FIG. 8, the rotation sensor 342 generates a rotation output ($\omega_x, \omega_y, \omega_z$) associated with the rotation of the 3D pointing device associated with the three coordinate axes of a spatial reference frame associated with the 3D pointing device (such as the reference frame $X_P Y_P Z_P$ shown in FIG. 1 and FIG. 2), the accelerometer 344 generates a first signal set including axial accelerations A_x, A_y and A_z associated with the movements and rotations of the 3D pointing device in the spatial reference frame, and then the computing processor 348 generates the orientation output based on the first signal set and the rotation output. For more details, please refer to the discussions related to FIG. 7 and FIG. 8 above.

[0093] The computing processor 348 may generate the aforementioned orientation

output in the form of a rotation matrix, a quaternion, a rotation vector, or in a form including the three orientation angles yaw, pitch and roll. The orientation output in the quaternion form may be the third quaternion generated in step 740 in FIG. 7 and FIG. 8. The three orientation angles, namely yaw, pitch and roll, may be generated in step 745 in FIG. 7 and FIG. 8. The computing processor 348 may obtain the rotation matrix from the orientation angles according to the following equation (22).

$$[R]_{3 \times 3} = \begin{bmatrix} \cos \theta \cos \psi & \sin \theta \sin \phi \cos \psi - \cos \phi \sin \psi & \sin \theta \cos \phi \cos \psi + \sin \phi \sin \psi \\ \cos \theta \sin \psi & \sin \theta \sin \phi \sin \psi + \cos \phi \cos \psi & \sin \theta \cos \phi \sin \psi - \sin \phi \cos \psi \\ -\sin \theta & \cos \theta \sin \phi & \cos \theta \cos \phi \end{bmatrix} \quad (22)$$

$[R]_{3 \times 3}$ is the orientation output in the form of a rotation matrix, θ is the pitch angle, ϕ is the roll angle and ψ is the yaw angle.

10

[0094] The computing processor 348 may also obtain the orientation output in the rotation matrix form from the quaternion form according to the following equation (23), wherein the quaternion form is represented as $\langle e_0, e_1, e_2, e_3 \rangle$.

$$[R]_{3 \times 3} = \begin{bmatrix} e_0^2 + e_1^2 - e_2^2 - e_3^2 & 2(e_1e_2 - e_0e_3) & 2(e_1e_3 + e_0e_2) \\ 2(e_1e_2 + e_0e_3) & e_0^2 - e_1^2 + e_2^2 - e_3^2 & 2(e_2e_3 - e_0e_1) \\ 2(e_1e_2 + e_0e_3) & 2(e_2e_3 + e_0e_1) & e_0^2 - e_1^2 - e_2^2 + e_3^2 \end{bmatrix} \dots\dots\dots (23)$$

15

[0095] Assume that the orientation output in the rotation vector form is represented as $\langle e_1, e_2, e_3 \rangle$ and the orientation output in the quaternion form is represented as $\langle e_0, e_1, e_2, e_3 \rangle$. The computing processor 348 may convert the rotation vector form to the quaternion form and convert the quaternion form to the rotation vector form according to the following equation (24).

20

$$\begin{aligned} \therefore e_0^2 + e_1^2 + e_2^2 + e_3^2 &= 1 \\ \therefore e_0^2 &= 1 - (e_1^2 + e_2^2 + e_3^2) \end{aligned} \dots\dots\dots (24)$$

One of the four forms of the orientation output may be converted to another of the four forms easily based on equations (22), (23) and (24).

5 **[0096]** In step 1340, the rotation sensor 342 generates a rotation output associated with the rotation of the 3D pointing device associated with the three coordinate axes of a spatial reference frame associated with the 3D pointing device itself (such as the reference frame $X_P Y_P Z_P$ shown in FIG. 1 and FIG. 2). In step 1360, the computing processor 1420 uses the orientation output and the rotation output to generate a
 10 transformed output $\langle d_x, d_y \rangle$ associated with the fixed reference frame associated with the display device. The transformed output $\langle d_x, d_y \rangle$ represents a 2-dimensional movement in a display plane in the fixed reference frame parallel to the screen of the display device, such as the display plane $X_D Y_D$ of the display device 120 shown in FIG. 1 and FIG. 2, wherein d_x represents the movement along the X_D axis and d_y represents
 15 the movement along the Y_D axis. In addition, the transformed output $\langle d_x, d_y \rangle$ may represent a segment of movement in the display plane. Multiple segments of movement plotted by the 3D pointing device may constitute a movement pattern in the display plane and the display device may be controlled to move a virtual object or a cursor along the movement pattern.

20 **[0097]** The step 1360 includes four sub-steps 1362, 1364, 1366 and 1368. In step 1362, the computing processor 1420 obtains the orientation of the display device associated with the global reference frame associated with the Earth. For example, the

3D pointing device may include a reset button. The user may point the 3D pointing device at the display device and press the reset button. The reset button may transmit a reset signal to the computing processor 1420. The computing processor 1420 may record the current orientation output generated by the orientation sensor 1410 as the orientation of the display device associated with the global reference frame upon receiving the reset signal. The orientation of the display device associated with the global reference frame associated with the Earth may be recorded as a reset yaw angle.

[0098] In step 1364, the computing processor 1420 obtains the orientation of the 3D pointing device associated with the fixed reference frame associated with the display device based on the orientation output and the orientation of the display device associated with the global reference frame associated with the Earth. As mentioned above, the current orientation output recorded by the computing processor 1420 may include a reset yaw angle associated with one of the three coordinate axes (such as the Z axis) of the global reference frame associated with the Earth. The computing processor 1420 may obtain the orientation of the 3D pointing device associated with the fixed reference frame associated with the display device by subtracting the reset yaw angle from the orientation output.

[0099] Step 705 shown in FIG. 7 and FIG. 8 is equivalent to steps 1362 and 1364. In an alternative embodiment of the present invention, in order to generate the orientation output in step 1320, the computing processor 348 may execute steps 705 to 745 shown in FIG. 7 and FIG. 8. In this case, the orientation output generated by the orientation sensor 1410 represents the orientation of the 3D pointing device associated

with the fixed reference frame associated with the display device. Therefore, the computing processor 1420 skips steps 1362 and 1364 in the alternative embodiment.

[00100] In step 1366, the computing processor 1420 generates a transformed rotation associated with the fixed reference frame associated with the display device based on the orientation of the 3D pointing device associated with the fixed reference frame associated with the display device and the rotation output. For example, the computing processor 1420 may generate the transformed rotation according to the following equation (25).

$$\begin{matrix} 10 & \begin{bmatrix} \omega_x \\ \omega_y \\ \omega_z \end{bmatrix}_D = \begin{bmatrix} R_{11} & R_{12} & R_{13} \\ R_{21} & R_{22} & R_{23} \\ R_{31} & R_{32} & R_{33} \end{bmatrix} \begin{bmatrix} \omega_x \\ \omega_y \\ \omega_z \end{bmatrix}_P \dots\dots\dots (25) \end{matrix}$$

R_{11} - R_{13} , R_{21} - R_{23} and R_{31} - R_{33} are the elements of the 3x3 rotation matrix obtained from the orientation of the 3D pointing device associated with the fixed reference frame associated with the display device. $[\omega_x \ \omega_y \ \omega_z]_D$ is the transformed rotation associated with the fixed reference frame associated with the display device. $[\omega_x \ \omega_y \ \omega_z]_P$ is the rotation output generated by the rotation sensor 342. The transformed rotation $[\omega_x \ \omega_y \ \omega_z]_D$ includes three angular velocities ω_x , ω_y and ω_z respectively associated with the three coordinate axes X_D , Y_D and Z_D of the fixed reference frame associated with the display device. The rotation output $[\omega_x \ \omega_y \ \omega_z]_P$ includes three angular velocities ω_x , ω_y and ω_z respectively associated with the three coordinate axes X_P , Y_P and Z_P of the spatial reference frame associated with the 3D pointing device.

[00101] In step 1368, the computing processor 1420 generates the transformed output

$\langle d_x, d_y \rangle$ based on the transformed rotation $[\omega_x \ \omega_y \ \omega_z]_D$. d_x is the first movement component of the transformed output associated with the coordinate axis X_D of the fixed reference frame associated with the display device, while d_y is the second movement component of the transformed output associated with the coordinate axis Y_D of the fixed reference frame associated with the display device. For example, the computing processor 1420 may multiply the angular velocity ω_y of the transformed rotation by a predetermined scale factor to generate the second movement component d_y and multiply the angular velocity ω_z of the transformed rotation by the same scale factor to generate the first movement component d_x . The value of the scale factor may be set by the user.

10

[00102] The method for compensating rotations of a 3D pointing device shown in FIG. 13 may be executed by the 3D pointing device shown in FIG. 15 as well. FIG. 15 is a schematic diagram showing another 3D pointing device according to an embodiment of the present invention. The 3D pointing device in FIG. 15 includes a rotation sensor 342, an orientation sensor 1510, and a computing processor 1420. The orientation sensor 1510 includes an accelerometer 344, a magnetometer 345, and a computing processor 348.

15

[00103] In step 1320, the orientation sensor 1510 generates an orientation output associated with the orientation of the 3D pointing device associated with the three coordinate axes of the global reference frame associated with the Earth. The computing processor 348 of the orientation sensor 1510 may generate the aforementioned orientation output by executing steps 1010 to 1060 illustrated in FIG. 10, steps 1110 to 1160 illustrated in FIG. 11, or steps 1210 to 1270 illustrated in FIG. 12. In brief, in the

20

aforementioned steps shown in FIG. 10, FIG. 11 or FIG. 12, the rotation sensor 342 generates a rotation output ($\omega_x, \omega_y, \omega_z$) associated with the rotation of the 3D pointing device associated with the three coordinate axes of the spatial reference frame associated with the 3D pointing device (such as the reference frame $X_P Y_P Z_P$ shown in FIG. 1 and FIG. 2), the accelerometer 344 generates a first signal set including axial accelerations A_x, A_y and A_z associated with the movements and rotations of the 3D pointing device in the spatial reference frame, the magnetometer 345 generates a second signal set (M_x, M_y, M_z) associated with the magnetism of the Earth, and then the computing processor 348 generates the orientation output based on the first signal set, the second signal set and the rotation output. For more details, please refer to the discussions regarding FIG. 10, FIG. 11 and FIG. 12 above.

[00104] The computing processor 348 may generate the aforementioned orientation output in the form of a rotation matrix, a quaternion, a rotation vector, or in a form including the three orientation angles yaw, pitch and roll. The orientation output in the quaternion form may be the third quaternion generated in step 1050 in FIG. 10, the fourth quaternion generated in step 1155 in FIG. 11, or may be obtained from the updated state in step 1265 in FIG. 12. The three orientation angles, namely yaw, pitch and roll, may be generated in step 1060 in FIG. 10, step 1160 in FIG. 11, or step 1270 in FIG. 12. The rotation matrix form and the rotation vector form may be obtained according to the aforementioned equations (22), (23) and (24).

[00105] In this embodiment, the rotation sensor 342 in FIG. 15 executes step 1340 as the rotation sensor 342 in FIG. 14 does, and the computing processor 1420 in FIG. 15

executes step 1360 as the computing processor 1420 in FIG. 14 does.

5 [00106] Step 1005 shown in FIG. 10 and step 1105 shown FIG. 11 are equivalent to steps 1362 and 1364. In an alternative embodiment of the present invention, in order to generate the orientation output in step 1320, the computing processor 348 in FIG. 15 may execute steps 1005 to 1060 shown in FIG. 10 or steps 1105 to 1160 shown in FIG. 8. In this case, the orientation output generated by the orientation sensor 1510 represents the orientation of the 3D pointing device associated with the fixed reference frame associated with the display device. Therefore, the computing processor 1420 in FIG. 15
10 skips steps 1362 and 1364 in the alternative embodiment.

[00107] The method for compensating rotations of a 3D pointing device shown in FIG. 13 may be executed by the 3D pointing device shown in FIG. 16 as well. FIG. 16 is a schematic diagram showing another 3D pointing device according to an
15 embodiment of the present invention. The 3D pointing device in FIG. 16 includes a rotation sensor 342, an orientation sensor 1610, and a computing processor 1420. The orientation sensor 1610 includes an accelerometer 344, a magnetometer 345, and a computing processor 348.

20 [00108] In step 1320, the orientation sensor 1610 generates an orientation output associated with the orientation of the 3D pointing device associated with the three coordinate axes of the global reference frame associated with the Earth. In order to generate the orientation output, the accelerometer 344 generates a first signal set including axial accelerations A_x , A_y and A_z associated with the movements and

rotations of the 3D pointing device in the spatial reference frame associated with the 3D pointing device itself, the magnetometer 345 generates a second signal set (Mx, My, Mz) associated with the magnetism of the Earth, and then the computing processor 348 in FIG. 16 generates the orientation output based on the first signal set and the second
 5 signal set. The details of the generation of the orientation output are discussed below.

[00109] The orientation output may be provided in a form including a yaw angle ψ , a pitch angle θ , and a roll angle ϕ respectively associated with the three coordinate axes of the global reference frame associated with the Earth. The first signal set includes
 10 axial accelerations Ax, Ay and Az respectively associated with the movements and rotations of the 3D pointing device along the X_P, Y_P and Z_P axes of the spatial reference frame associated with the 3D pointing device itself. The second signal set includes magnetism Mx, My, Mz associated with the movements and rotations of the 3D pointing device along each of the three orthogonal coordinate axes X_PY_PZ_P of the
 15 spatial reference frame associated with the 3D pointing device, respectively.

[00110] The computing processor 348 may calculate the pitch angle θ and the roll angle ϕ according to the following equations (26) and (27).

$$\theta = \sin^{-1}\left(\frac{Ax}{g}\right) \dots\dots\dots (26)$$

$$\phi = \sin^{-1}\left(\frac{Ay}{g \cos \theta}\right) \text{ or } \phi = \cos^{-1}\left(\frac{Az}{g \cos \theta}\right) \dots\dots\dots (27)$$

In equations (26) and (27), Ax, Ay and Az are axial accelerations of the first signal set, while g is the gravitational acceleration. In addition, the computing processor 348 may calculate the yaw angle ψ according to the following equation (28).

$$\psi = \tan^{-1}\left(\frac{-My \cos \phi + Mz \sin \phi}{Mx \cos \theta + My \sin \theta \sin \phi + Mz \sin \theta \cos \phi}\right) \dots\dots\dots (28)$$

In equation (28), Mx, My and Mz are the aforementioned elements of the second signal set. The computing processor 348 in FIG. 16 may generate the orientation output including the yaw angle ψ , the pitch angle θ , and the roll angle ϕ according to equations (26), (27) and (28).

[00111] In this embodiment, the rotation sensor 342 in FIG. 16 executes step 1340 as the rotation sensor 342 in FIG. 14 does, and the computing processor 1420 in FIG. 16 executes step 1360 as the computing processor 1420 in FIG. 14 does.

[00112] The method shown in FIG. 13 and the 3D pointing devices shown in FIG. 14 to FIG. 16 can transform 3D rotations and movements of the pointing devices into a 2D movement pattern in the display plane of the display device. The transformation of conventional pointing devices fails to take every one of the yaw, pitch and roll angles into account and their transformation is erroneous in some circumstances. For example, a conventional pointing device may transform its rotation to movement along an exactly opposite direction when the conventional pointing device is flipped over. On the other hand, the method shown in FIG. 13 and the 3D pointing devices shown in FIG. 14 to FIG. 16 can transform the rotations and movements of the 3D pointing devices correctly no matter how they are oriented or turned because the transformation of the embodiments of the present invention takes every one of the yaw, pitch and roll angles into account.

[00113] It may be understood that the present invention may be applied to various

scenarios and application fields including such as gaming, computers and navigation. It may too be understood that the scope of the present invention shall be determined by the accompanying claims and shall include variations of applications of the present invention as well as differences in the term definitions used or related to including such

5 as pointing devices, navigation equipment, smartphone and/or electronic devices.

WHAT IS CLAIMED IS:

1. A 3D pointing device, comprising:

an orientation sensor, generating an orientation output associated with an orientation of the 3D pointing device associated with three coordinate axes of a global reference frame associated with Earth;

a rotation sensor, generating a rotation output associated with a rotation of the 3D pointing device associated with three coordinate axes of a spatial reference frame associated with the 3D pointing device; and

a first computing processor, using the orientation output and the rotation output to generate a transformed output associated with a fixed reference frame associated with a display device.

2. The 3D pointing device of claim 1, wherein the orientation sensor comprises:

an accelerometer, generating a first signal set comprising axial accelerations associated with movements and rotations of the 3D pointing device in the spatial reference frame; and

a second computing processor, generating the orientation output based on the first signal set and the rotation output.

3. The 3D pointing device of claim 2, wherein the orientation sensor further comprises:

a magnetometer, generating a second signal set associated with Earth's magnetism, wherein the second computing processor further generates the orientation output based on the first signal set, the second signal set and the rotation output or based on the first signal set and the second signal set.

4. The 3D pointing device of claim 3, wherein the orientation output comprises a

yaw angle, a pitch angle, and a roll angle associated with the three coordinate axes of the global reference frame; the first signal set comprises a first axial acceleration, a second axial acceleration, and a third axial acceleration; the second computing processor calculates the pitch angle based on the first axial acceleration, calculates the roll angle based on the second axial acceleration and the pitch angle or based on the third axial acceleration and the pitch angle, and calculates the yaw angle based on the pitch angle, the roll angle, and the second signal set.

5

5. The 3D pointing device of claim 1, wherein the orientation output provided by the orientation sensor is a rotation matrix, a quaternion, a rotation vector, or comprises three orientation angles.

10

6. The 3D pointing device of claim 1, wherein the transformed output represents a segment of a movement in a plane in the fixed reference frame parallel to a screen of the display device.

7. The 3D pointing device of claim 1, wherein the first computing processor obtains an orientation of the display device associated with the global reference frame, obtains an orientation of the 3D pointing device associated with the fixed reference frame based on the orientation output and the orientation of the display device associated with the global reference frame, generates a transformed rotation associated with the fixed reference frame based on the orientation of the 3D pointing device associated with the fixed reference frame and the rotation output, and generates the transformed output based on the transformed rotation.

15

20

8. The 3D pointing device of claim 7, wherein when the first computing processor receives a reset signal, the first computing processor records a current orientation output generated by the orientation sensor as the orientation of the display device associated

with the global reference frame.

9. The 3D pointing device of claim 8, wherein the current orientation output comprises a yaw angle associated with one of the three coordinate axes of the global reference frame, the first computing processor obtains the orientation of the 3D pointing device associated with the fixed reference frame by subtracting the yaw angle from the orientation output.

10. The 3D pointing device of claim 7, wherein the first computing processor obtains a rotation matrix from the orientation of the 3D pointing device associated with the fixed reference frame, and multiplies the rotation matrix and the rotation output together to generate the transformed rotation.

11. The 3D pointing device of claim 10, wherein the transformed rotation comprises a first angular velocity, a second angular velocity, and a third angular velocity associated with three coordinate axes of the fixed reference frame; the transformed output comprises a first movement component and a second movement component associated with two of the three coordinate axes of the fixed reference frame; the first computing processor multiplies the second angular velocity by a scale factor to generate the second movement component and multiplies the third angular velocity by the scale factor to generate the first movement component.

12. A method for compensating rotations of a 3D pointing device, comprising:
generating an orientation output associated with an orientation of the 3D pointing device associated with three coordinate axes of a global reference frame associated with Earth;

generating a rotation output associated with a rotation of the 3D pointing device associated with three coordinate axes of a spatial reference frame associated with the 3D

pointing device; and

using the orientation output and the rotation output to generate a transformed output associated with a fixed reference frame associated with a display device.

5 13. The method of claim 12, wherein the step of generating the orientation output comprises:

generating a first signal set comprising axial accelerations associated with movements and rotations of the 3D pointing device in the spatial reference frame; and

generating the orientation output based on the first signal set and the rotation output.

10 14. The method of claim 13, wherein the step of generating the orientation output further comprises:

generating a second signal set associated with Earth's magnetism; and

generating the orientation output based on the first signal set, the second signal set and the rotation output or based on the first signal set and the second signal set.

15 15. The method of claim 14, wherein the orientation output comprises a yaw angle, a pitch angle, and a roll angle associated with the three coordinate axes of the global reference frame; the first signal set comprises a first axial acceleration, a second axial acceleration, and a third axial acceleration; the step of generating the orientation output based on the first signal set and the second signal set comprises:

20 calculating the pitch angle based on the first axial acceleration;

calculating the roll angle based on the second axial acceleration and the pitch angle or based on the third axial acceleration and the pitch angle; and

calculating the yaw angle based on the pitch angle, the roll angle, and the second signal set.

16. The method of claim 12, wherein the orientation output is a rotation matrix, a quaternion, a rotation vector, or comprises three orientation angles.

17. The method of claim 12, wherein the transformed output represents a segment of a movement in a plane in the fixed reference frame parallel to a screen of the display device.

18. The method of claim 12, wherein the step of generating the transformed output comprises:

obtaining an orientation of the display device associated with the global reference frame;

obtaining an orientation of the 3D pointing device associated with the fixed reference frame based on the orientation output and the orientation of the display device associated with the global reference frame;

generating a transformed rotation associated with the fixed reference frame based on the orientation of the 3D pointing device associated with the fixed reference frame and the rotation output; and

generating the transformed output based on the transformed rotation.

19. The method of claim 18, wherein the step of obtaining the orientation of the display device associated with the global reference frame comprises:

recording a current orientation output as the orientation of the display device associated with the global reference frame in response to a reset signal.

20. The method of claim 19, wherein the current orientation output comprises a yaw angle associated with one of the three coordinate axes of the global reference frame, and the step of obtaining the orientation of the 3D pointing device associated with the fixed reference frame comprises:

obtaining the orientation of the 3D pointing device associated with the fixed reference frame by subtracting the yaw angle from the orientation output.

21. The method of claim 18, wherein the step of generating the transformed rotation comprises:

5 obtaining a rotation matrix from the orientation of the 3D pointing device associated with the fixed reference frame; and

 multiplying the rotation matrix and the rotation output together to generate the transformed rotation.

22. The method of claim 21, wherein the transformed rotation comprises a first
10 angular velocity, a second angular velocity, and a third angular velocity associated with three coordinate axes of the fixed reference frame; the transformed output comprises a first movement component and a second movement component associated with two of the three coordinate axes of the fixed reference frame; the step of generating the transformed output based on the transformed rotation comprises:

15 multiplying the second angular velocity by a scale factor to generate the second movement component; and

 multiplying the third angular velocity by the scale factor to generate the first movement component.

ABSTRACT OF THE DISCLOSURE

A 3D pointing device utilizing an orientation sensor, capable of accurately transforming rotations and movements of the 3D pointing device into a movement pattern in the display plane of a display device is provided. The 3D pointing device includes the orientation sensor, a rotation sensor, and a computing processor. The orientation sensor generates an orientation output associated with the orientation of the 3D pointing device associated with three coordinate axes of a global reference frame associated with the Earth. The rotation sensor generates a rotation output associated with the rotation of the 3D pointing device associated with three coordinate axes of a spatial reference frame associated with the 3D pointing device itself. The computing processor uses the orientation output and the rotation output to generate a transformed output associated with a fixed reference frame associated with the display device above. The transformed output represents a segment of the movement pattern.

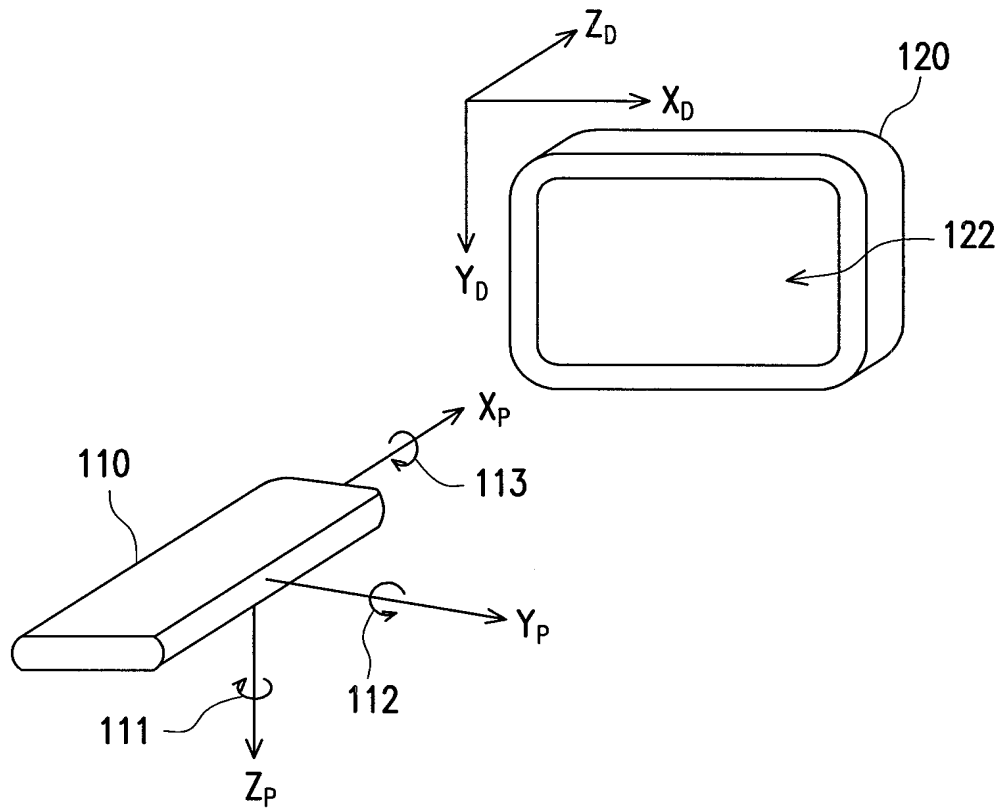

FIG. 1 (RELATED ART)

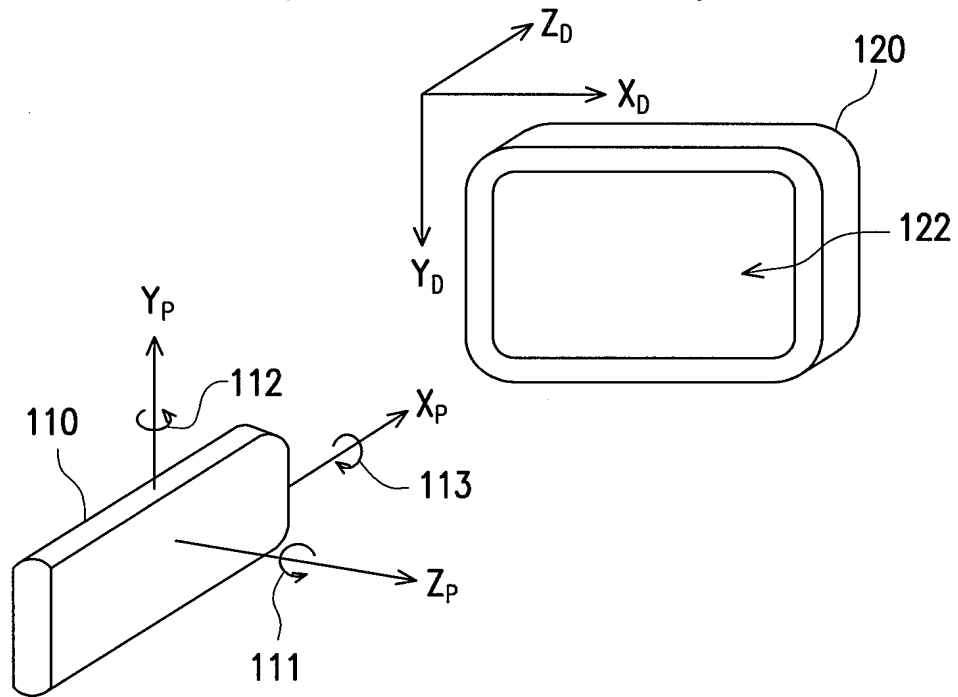

FIG. 2 (RELATED ART)

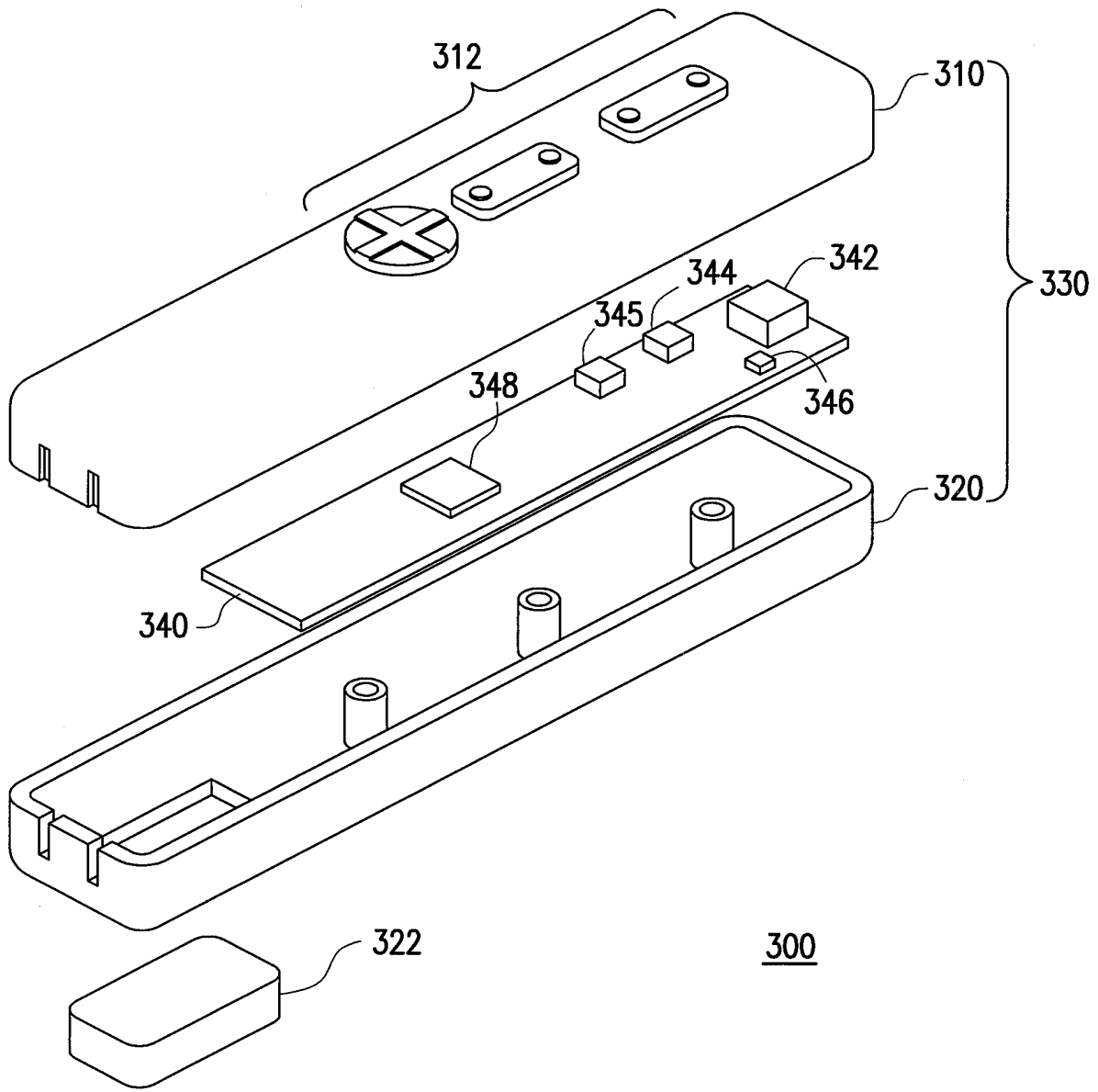

FIG. 3

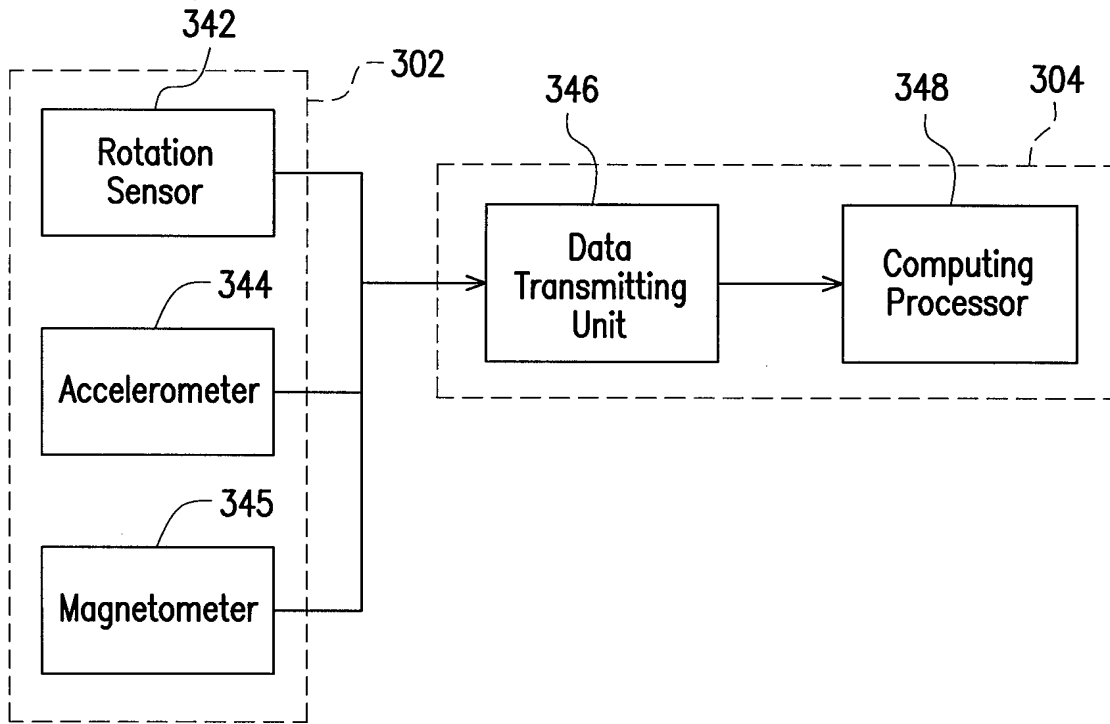

FIG. 4

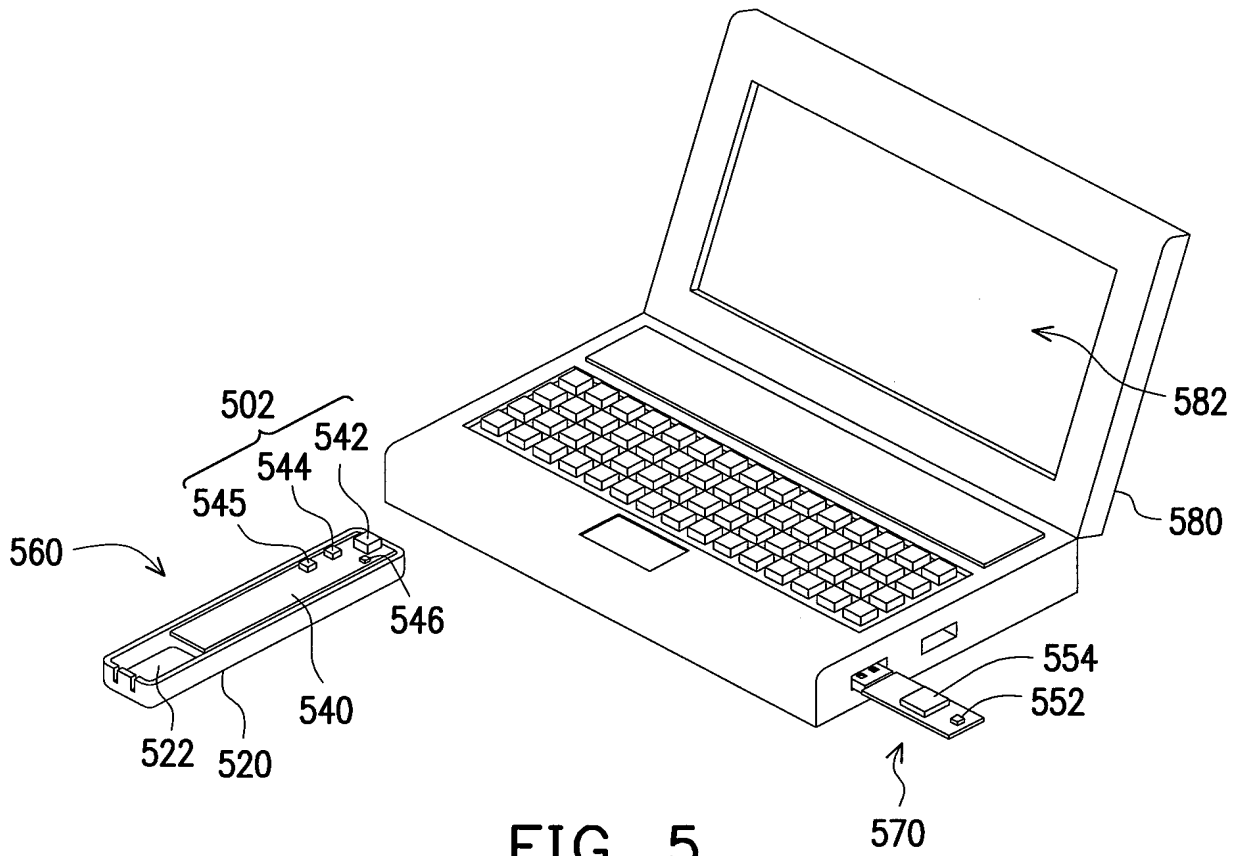

FIG. 5

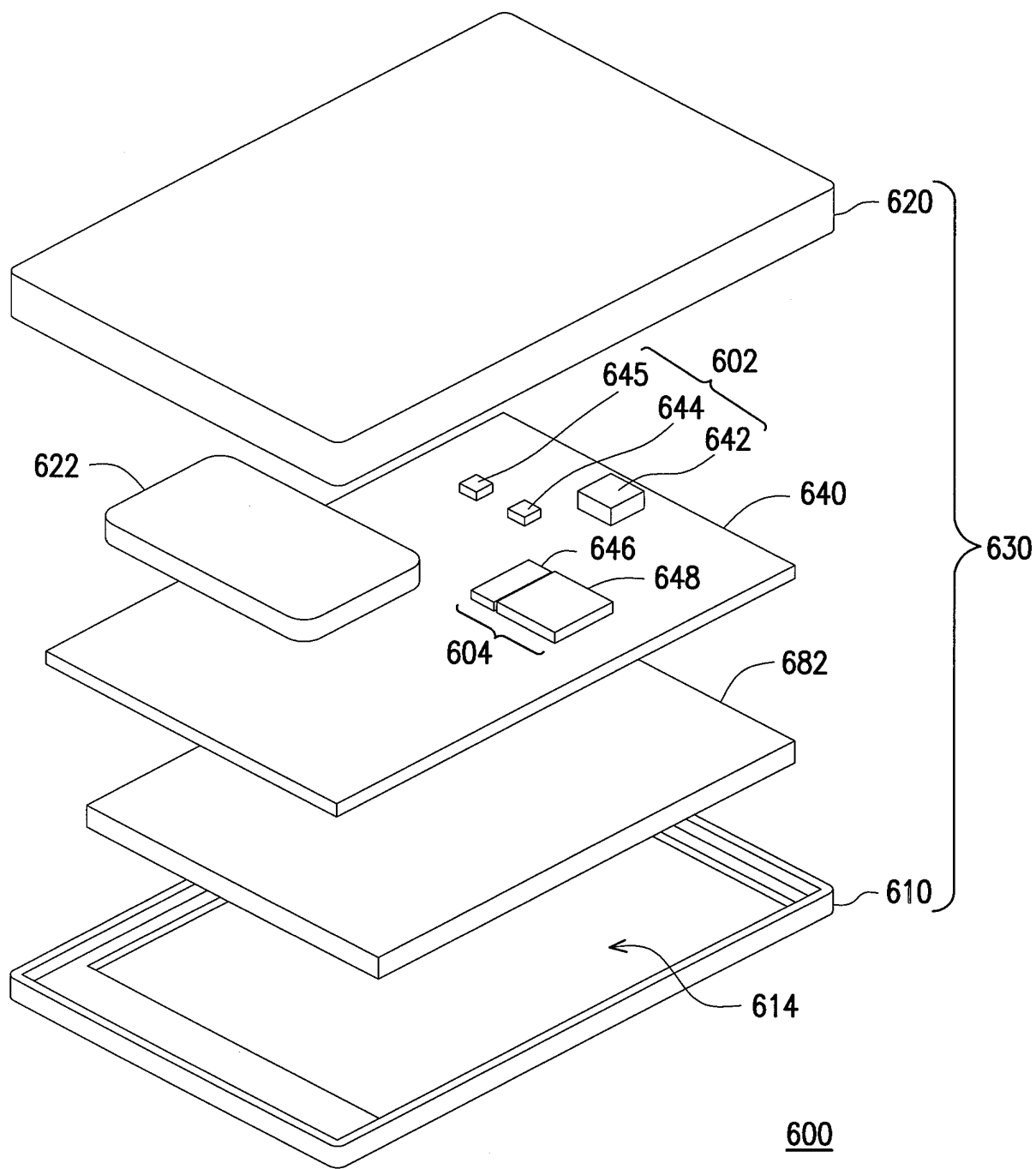

FIG. 6

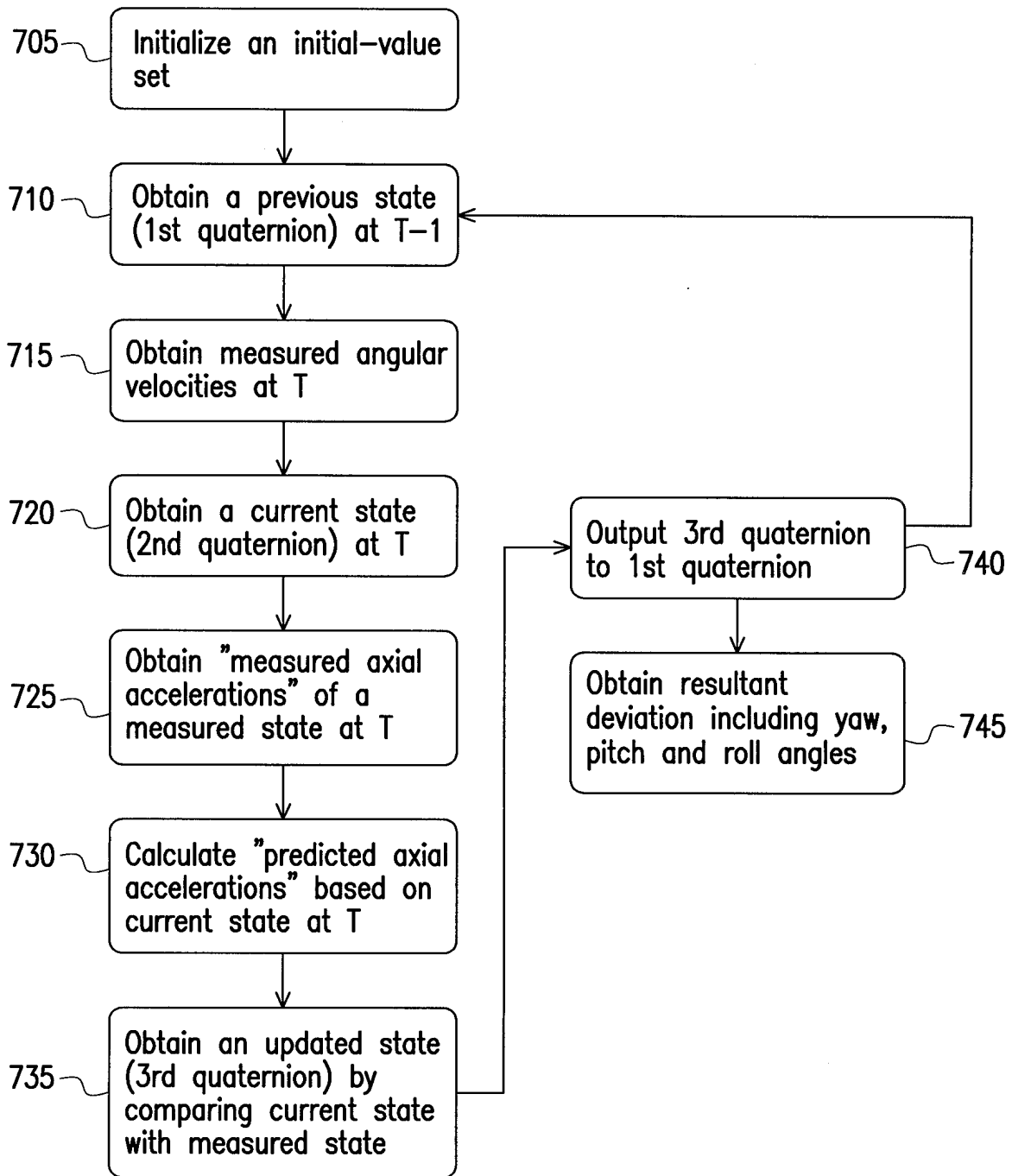

FIG. 7

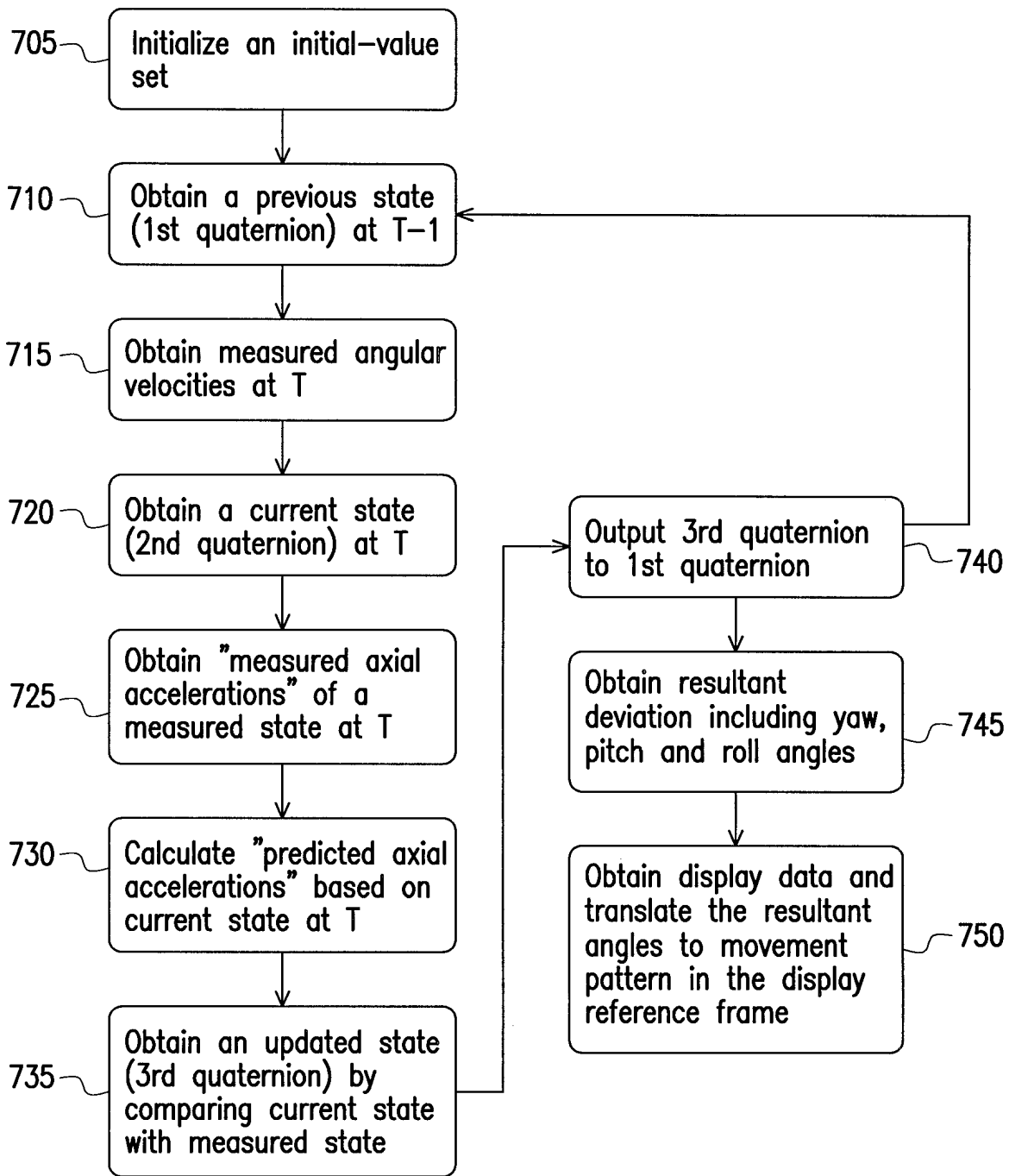

FIG. 8

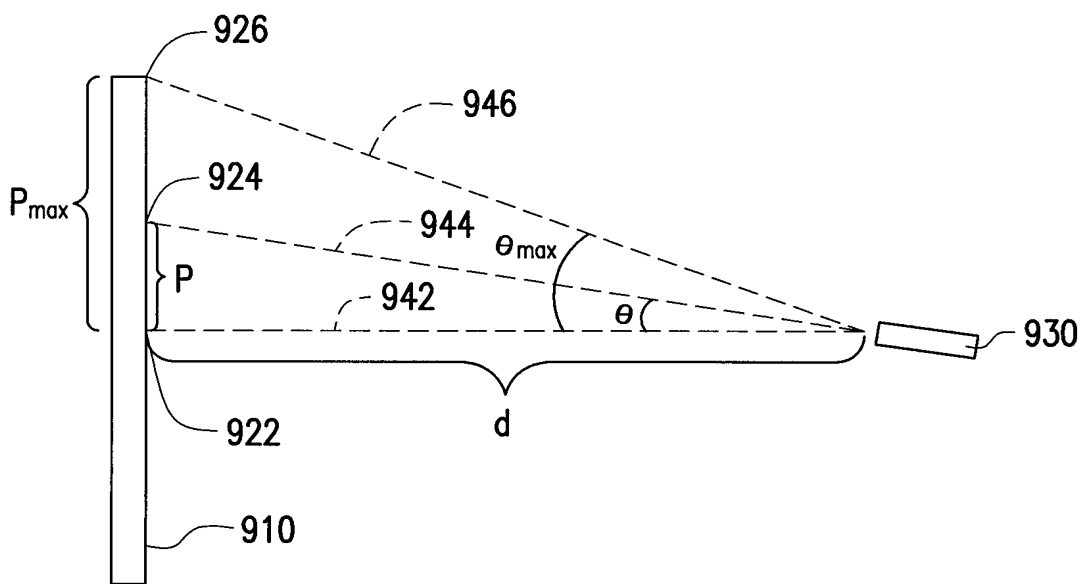

FIG. 9

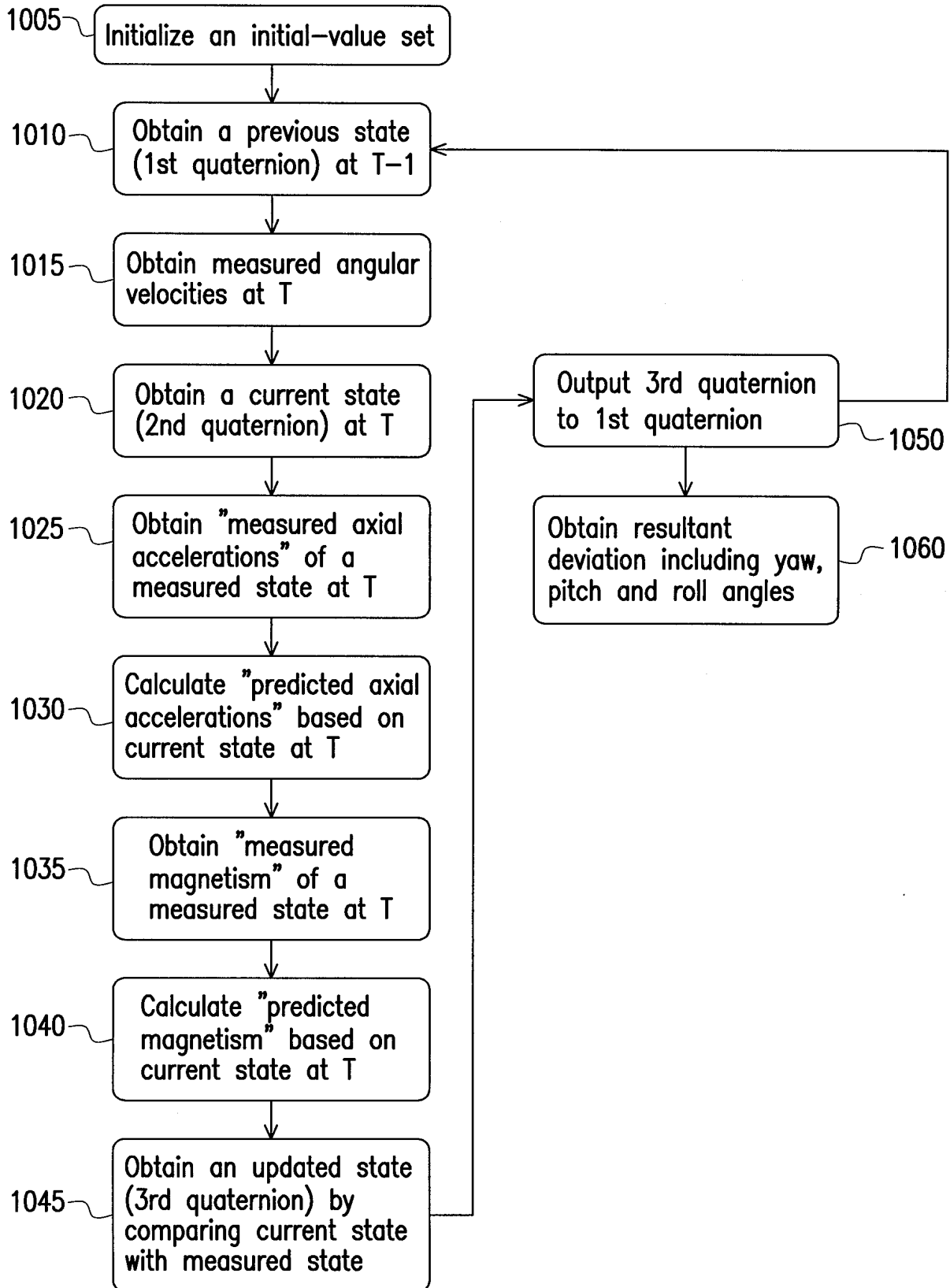

FIG. 10

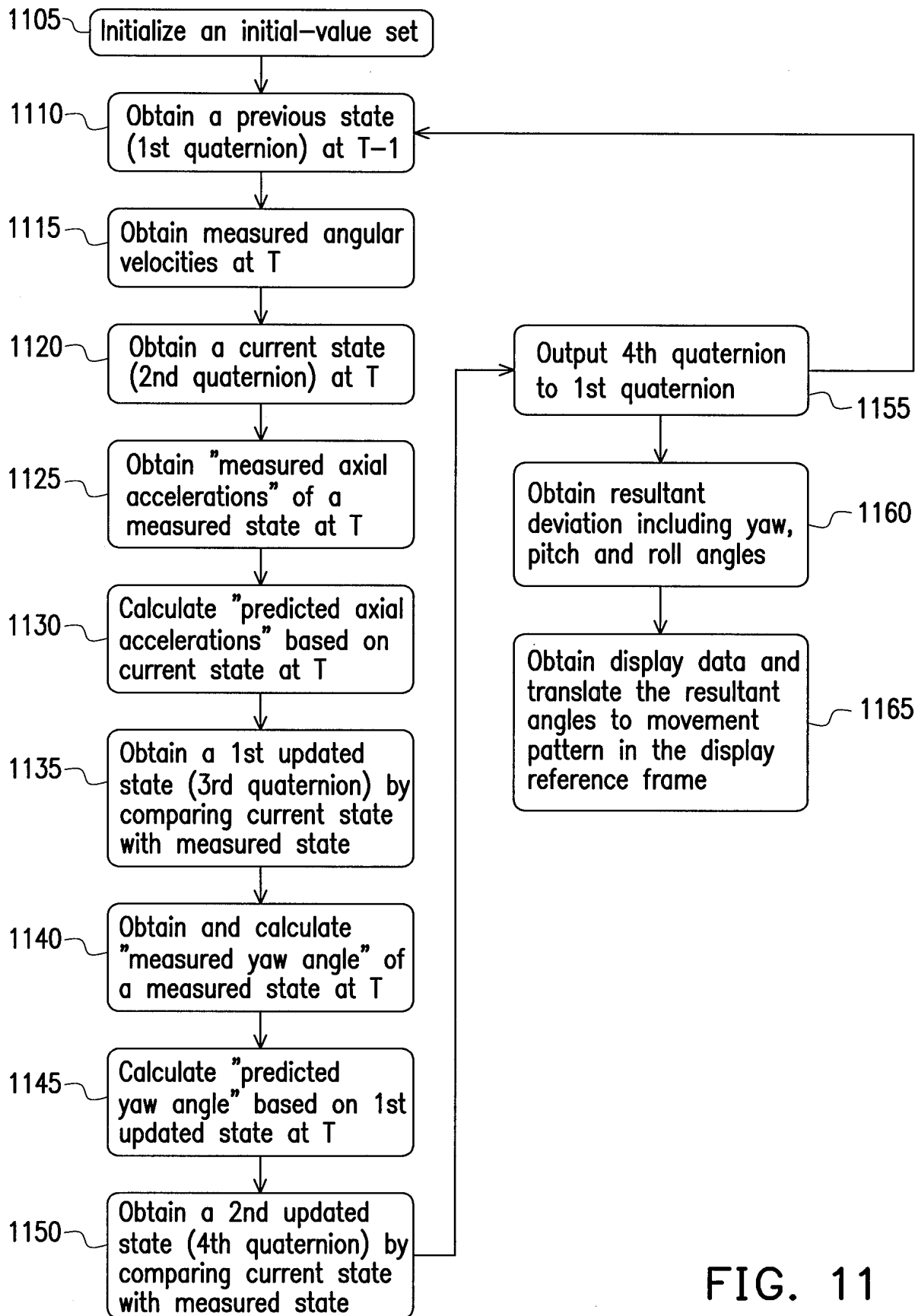

FIG. 11

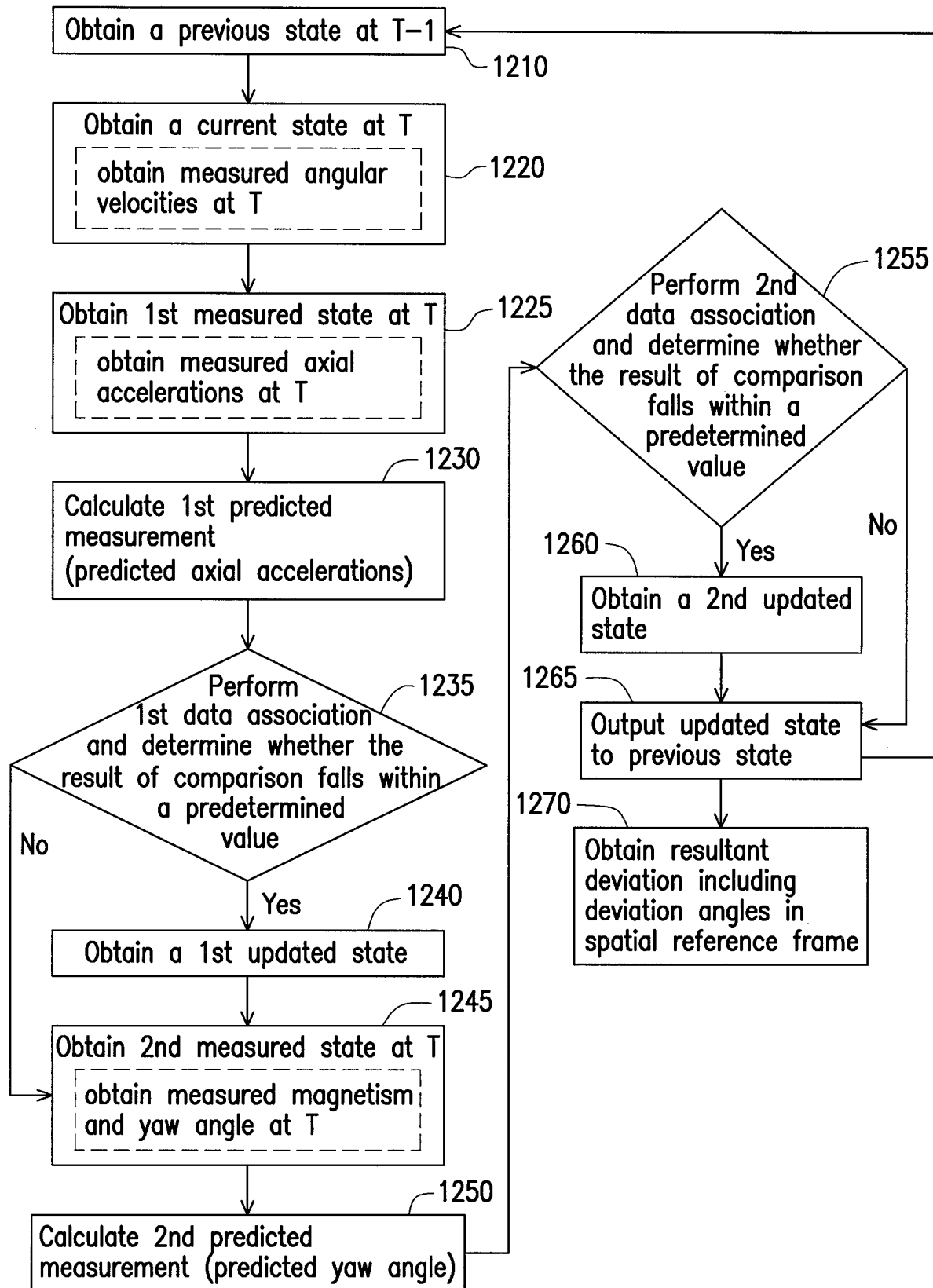

FIG. 12

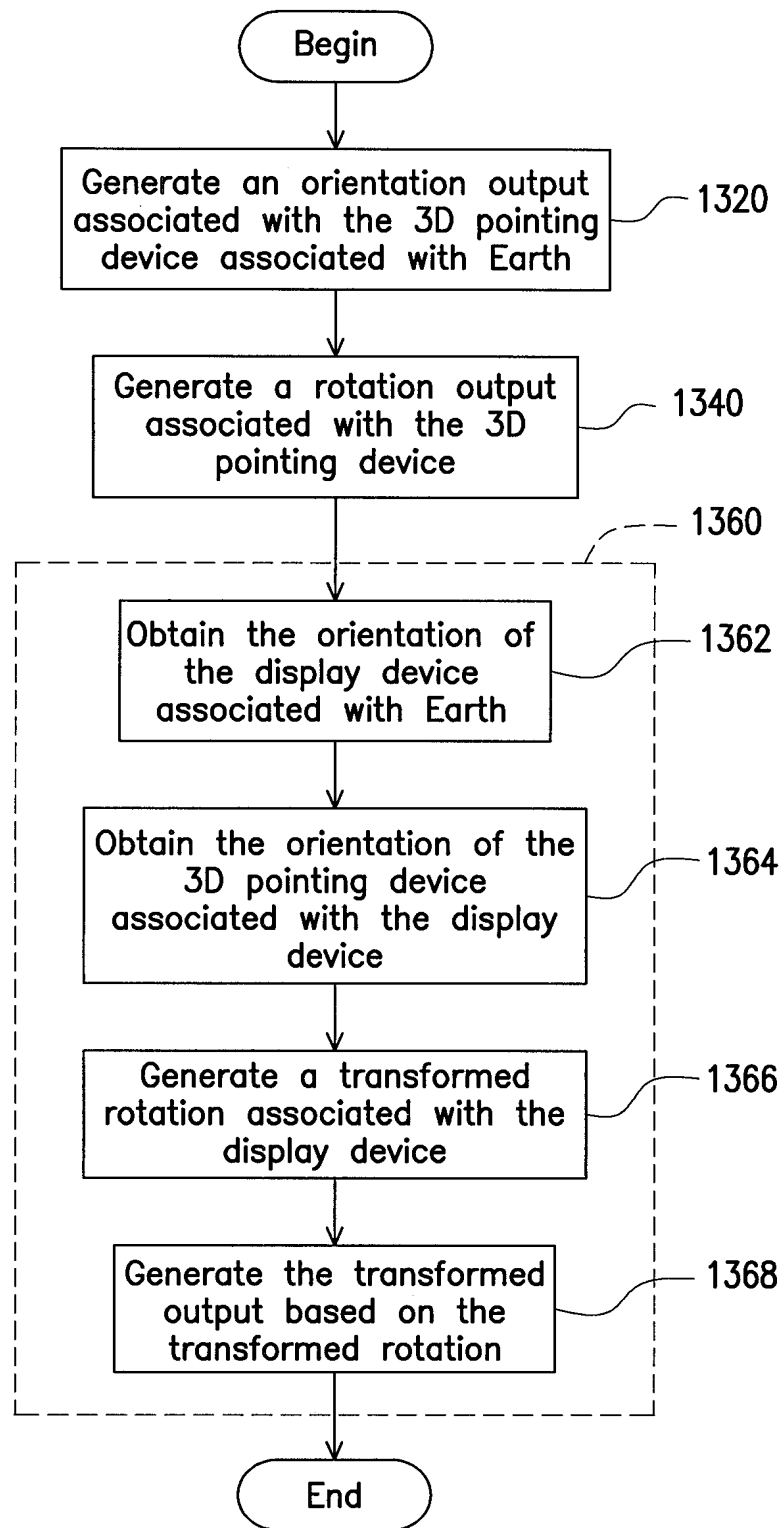

FIG. 13

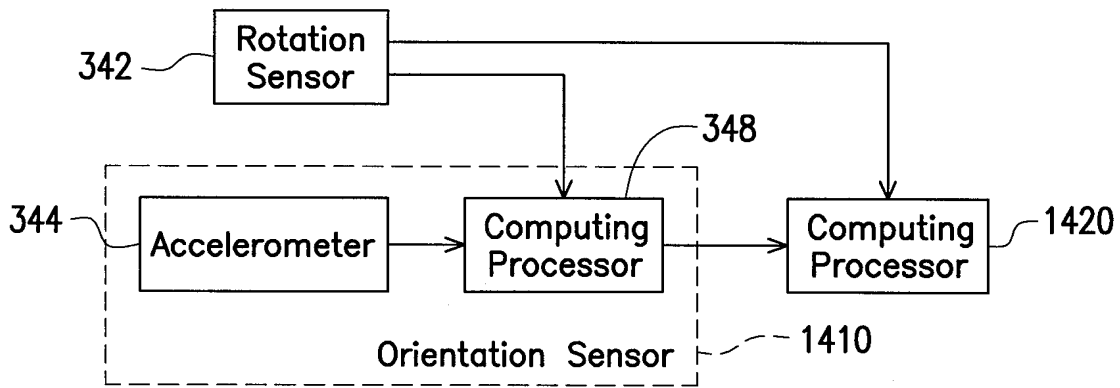

FIG. 14

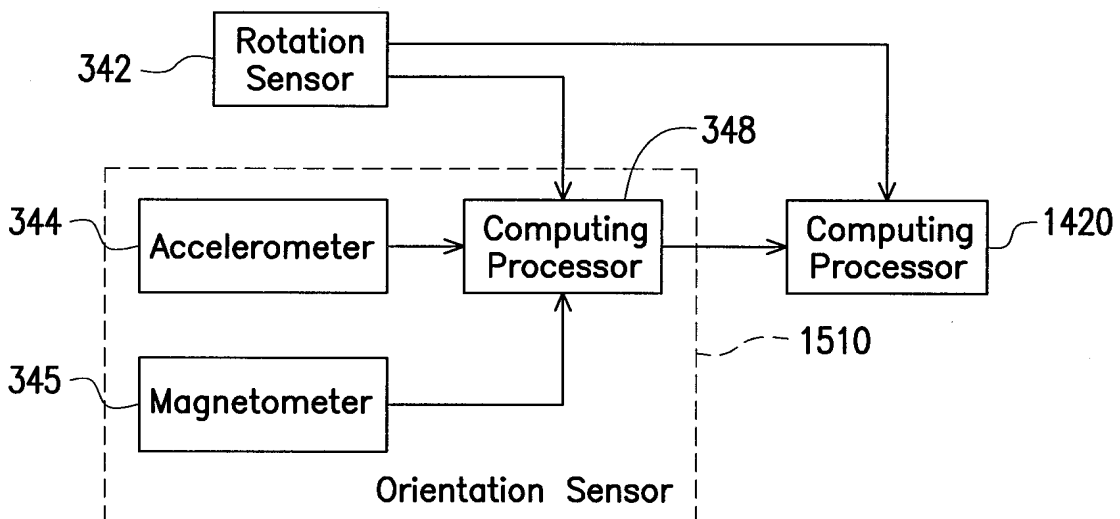

FIG. 15

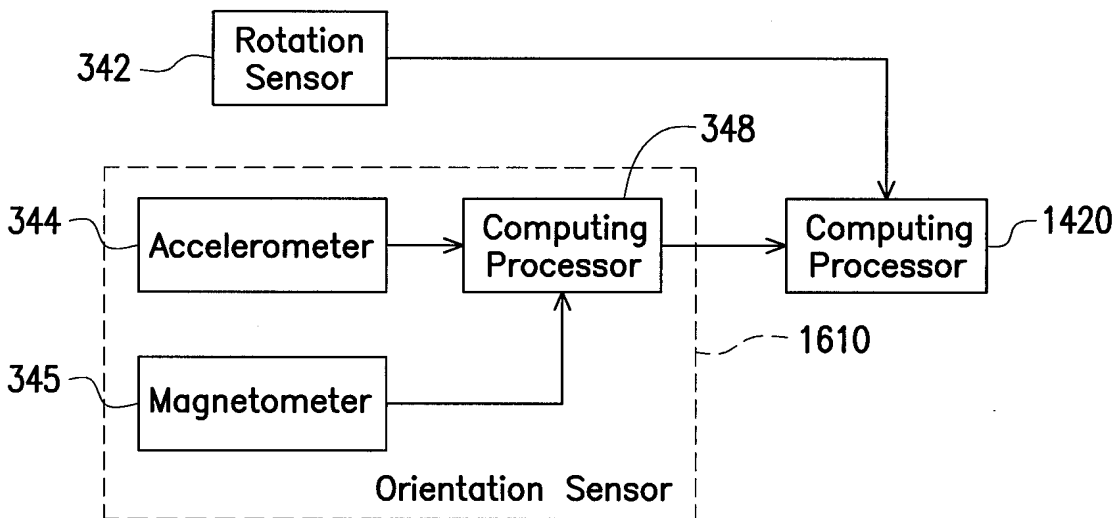

FIG. 16

INFORMATION DISCLOSURE STATEMENT BY APPLICANT (Not for submission under 37 CFR 1.99)	Application Number		
	Filing Date		
	First Named Inventor	Zhou Ye	
	Art Unit		
	Examiner Name		
	Attorney Docket Number	35822-US-PA-0P-2	

U.S.PATENTS						Remove
Examiner Initial*	Cite No	Patent Number	Kind Code ¹	Issue Date	Name of Patentee or Applicant of cited Document	Pages,Columns,Lines where Relevant Passages or Relevant Figures Appear
	1	5138154		1992-08-11	Hotelling	
	2	5440326		1995-08-08	Quinn	
	3	5898421		1999-04-27	Quinn	
	4	7158118		2007-01-02	Liberty	
	5	7236156		2007-06-26	Liberty , et al.	
	6	7239301		2007-07-03	Liberty , et al.	
	7	7262760		2007-08-28	Liberty	
	8	7414611		2008-08-19	Liberty	

**INFORMATION DISCLOSURE
STATEMENT BY APPLICANT**
(Not for submission under 37 CFR 1.99)

Application Number		
Filing Date		
First Named Inventor	Zhou Ye	
Art Unit		
Examiner Name		
Attorney Docket Number	35822-US-PA-0P-2	

	9	7489298		2009-02-10	Liberty , et al.	
	10	7535456		2009-05-19	Liberty , et al.	

If you wish to add additional U.S. Patent citation information please click the Add button. Add

U.S.PATENT APPLICATION PUBLICATIONS Remove

Examiner Initial*	Cite No	Publication Number	Kind Code ¹	Publication Date	Name of Patentee or Applicant of cited Document	Pages,Columns,Lines where Relevant Passages or Relevant Figures Appear
	1					

If you wish to add additional U.S. Published Application citation information please click the Add button. Add

FOREIGN PATENT DOCUMENTS Remove

Examiner Initial*	Cite No	Foreign Document Number ³	Country Code ² j	Kind Code ⁴	Publication Date	Name of Patentee or Applicant of cited Document	Pages,Columns,Lines where Relevant Passages or Relevant Figures Appear	T ⁵
	1							<input type="checkbox"/>

If you wish to add additional Foreign Patent Document citation information please click the Add button Add

NON-PATENT LITERATURE DOCUMENTS Remove

Examiner Initials*	Cite No	Include name of the author (in CAPITAL LETTERS), title of the article (when appropriate), title of the item (book, magazine, journal, serial, symposium, catalog, etc), date, pages(s), volume-issue number(s), publisher, city and/or country where published.	T ⁵
	1		<input type="checkbox"/>

If you wish to add additional non-patent literature document citation information please click the Add button Add

**INFORMATION DISCLOSURE
STATEMENT BY APPLICANT**
(Not for submission under 37 CFR 1.99)

Application Number		
Filing Date		
First Named Inventor	Zhou Ye	
Art Unit		
Examiner Name		
Attorney Docket Number	35822-US-PA-0P-2	

EXAMINER SIGNATURE

Examiner Signature		Date Considered	
--------------------	--	-----------------	--

*EXAMINER: Initial if reference considered, whether or not citation is in conformance with MPEP 609. Draw line through a citation if not in conformance and not considered. Include copy of this form with next communication to applicant.

¹ See Kind Codes of USPTO Patent Documents at www.USPTO.GOV or MPEP 901.04. ² Enter office that issued the document, by the two-letter code (WIPO Standard ST.3). ³ For Japanese patent documents, the indication of the year of the reign of the Emperor must precede the serial number of the patent document. ⁴ Kind of document by the appropriate symbols as indicated on the document under WIPO Standard ST.16 if possible. ⁵ Applicant is to place a check mark here if English language translation is attached.

**INFORMATION DISCLOSURE
STATEMENT BY APPLICANT**
(Not for submission under 37 CFR 1.99)

Application Number		
Filing Date		
First Named Inventor	Zhou Ye	
Art Unit		
Examiner Name		
Attorney Docket Number	35822-US-PA-0P-2	

CERTIFICATION STATEMENT

Please see 37 CFR 1.97 and 1.98 to make the appropriate selection(s):

That each item of information contained in the information disclosure statement was first cited in any communication from a foreign patent office in a counterpart foreign application not more than three months prior to the filing of the information disclosure statement. See 37 CFR 1.97(e)(1).

OR

That no item of information contained in the information disclosure statement was cited in a communication from a foreign patent office in a counterpart foreign application, and, to the knowledge of the person signing the certification after making reasonable inquiry, no item of information contained in the information disclosure statement was known to any individual designated in 37 CFR 1.56(c) more than three months prior to the filing of the information disclosure statement. See 37 CFR 1.97(e)(2).

See attached certification statement.

Fee set forth in 37 CFR 1.17 (p) has been submitted herewith.

None

SIGNATURE

A signature of the applicant or representative is required in accordance with CFR 1.33, 10.18. Please see CFR 1.4(d) for the form of the signature.

Signature	/Belinda Lee/	Date (YYYY-MM-DD)	2011-07-06
Name/Print	Belinda Lee	Registration Number	46863

This collection of information is required by 37 CFR 1.97 and 1.98. The information is required to obtain or retain a benefit by the public which is to file (and by the USPTO to process) an application. Confidentiality is governed by 35 U.S.C. 122 and 37 CFR 1.14. This collection is estimated to take 1 hour to complete, including gathering, preparing and submitting the completed application form to the USPTO. Time will vary depending upon the individual case. Any comments on the amount of time you require to complete this form and/or suggestions for reducing this burden, should be sent to the Chief Information Officer, U.S. Patent and Trademark Office, U.S. Department of Commerce, P.O. Box 1450, Alexandria, VA 22313-1450. **DO NOT SEND FEES OR COMPLETED FORMS TO THIS ADDRESS. SEND TO: Commissioner for Patents, P.O. Box 1450, Alexandria, VA 22313-1450.**

Privacy Act Statement

The Privacy Act of 1974 (P.L. 93-579) requires that you be given certain information in connection with your submission of the attached form related to a patent application or patent. Accordingly, pursuant to the requirements of the Act, please be advised that: (1) the general authority for the collection of this information is 35 U.S.C. 2(b)(2); (2) furnishing of the information solicited is voluntary; and (3) the principal purpose for which the information is used by the U.S. Patent and Trademark Office is to process and/or examine your submission related to a patent application or patent. If you do not furnish the requested information, the U.S. Patent and Trademark Office may not be able to process and/or examine your submission, which may result in termination of proceedings or abandonment of the application or expiration of the patent.

The information provided by you in this form will be subject to the following routine uses:

1. The information on this form will be treated confidentially to the extent allowed under the Freedom of Information Act (5 U.S.C. 552) and the Privacy Act (5 U.S.C. 552a). Records from this system of records may be disclosed to the Department of Justice to determine whether the Freedom of Information Act requires disclosure of these records.
2. A record from this system of records may be disclosed, as a routine use, in the course of presenting evidence to a court, magistrate, or administrative tribunal, including disclosures to opposing counsel in the course of settlement negotiations.
3. A record in this system of records may be disclosed, as a routine use, to a Member of Congress submitting a request involving an individual, to whom the record pertains, when the individual has requested assistance from the Member with respect to the subject matter of the record.
4. A record in this system of records may be disclosed, as a routine use, to a contractor of the Agency having need for the information in order to perform a contract. Recipients of information shall be required to comply with the requirements of the Privacy Act of 1974, as amended, pursuant to 5 U.S.C. 552a(m).
5. A record related to an International Application filed under the Patent Cooperation Treaty in this system of records may be disclosed, as a routine use, to the International Bureau of the World Intellectual Property Organization, pursuant to the Patent Cooperation Treaty.
6. A record in this system of records may be disclosed, as a routine use, to another federal agency for purposes of National Security review (35 U.S.C. 181) and for review pursuant to the Atomic Energy Act (42 U.S.C. 218(c)).
7. A record from this system of records may be disclosed, as a routine use, to the Administrator, General Services, or his/her designee, during an inspection of records conducted by GSA as part of that agency's responsibility to recommend improvements in records management practices and programs, under authority of 44 U.S.C. 2904 and 2906. Such disclosure shall be made in accordance with the GSA regulations governing inspection of records for this purpose, and any other relevant (i.e., GSA or Commerce) directive. Such disclosure shall not be used to make determinations about individuals.
8. A record from this system of records may be disclosed, as a routine use, to the public after either publication of the application pursuant to 35 U.S.C. 122(b) or issuance of a patent pursuant to 35 U.S.C. 151. Further, a record may be disclosed, subject to the limitations of 37 CFR 1.14, as a routine use, to the public if the record was filed in an application which became abandoned or in which the proceedings were terminated and which application is referenced by either a published application, an application open to public inspections or an issued patent.
9. A record from this system of records may be disclosed, as a routine use, to a Federal, State, or local law enforcement agency, if the USPTO becomes aware of a violation or potential violation of law or regulation.

Electronic Patent Application Fee Transmittal

Application Number:				
Filing Date:				
Title of Invention:	3D POINTING DEVICE AND METHOD FOR COMPENSATING ROTATIONS OF THE 3D POINTING DEVICE THEREOF			
First Named Inventor/Applicant Name:	Zhou Ye			
Filer:	Belinda Lee			
Attorney Docket Number:	35822-US-PA-0P-2			
Filed as Small Entity				
Utility under 35 USC 111(a) Filing Fees				
Description	Fee Code	Quantity	Amount	Sub-Total in USD(\$)
Basic Filing:				
Utility filing Fee (Electronic filing)	4011	1	82	82
Utility Search Fee	2111	1	270	270
Utility Examination Fee	2311	1	110	110
Pages:				
Claims:				
Claims in excess of 20	2202	2	26	52
Miscellaneous-Filing:				
Petition:				

Description	Fee Code	Quantity	Amount	Sub-Total in USD(\$)
Patent-Appeals-and-Interference:				
Post-Allowance-and-Post-Issuance:				
Extension-of-Time:				
Miscellaneous:				
Total in USD (\$)				514

Electronic Acknowledgement Receipt

EFS ID:	10456871
Application Number:	13176771
International Application Number:	
Confirmation Number:	5154
Title of Invention:	3D POINTING DEVICE AND METHOD FOR COMPENSATING ROTATIONS OF THE 3D POINTING DEVICE THEREOF
First Named Inventor/Applicant Name:	Zhou Ye
Customer Number:	31561
Filer:	Belinda Lee
Filer Authorized By:	
Attorney Docket Number:	35822-US-PA-0P-2
Receipt Date:	06-JUL-2011
Filing Date:	
Time Stamp:	07:33:18
Application Type:	Utility under 35 USC 111(a)

Payment information:

Submitted with Payment	yes
Payment Type	Credit Card
Payment was successfully received in RAM	\$514
RAM confirmation Number	7687
Deposit Account	502620
Authorized User	HUAI-LU,LEE-

The Director of the USPTO is hereby authorized to charge indicated fees and credit any overpayment as follows:

Charge any Additional Fees required under 37 C.F.R. Section 1.16 (National application filing, search, and examination fees)

Charge any Additional Fees required under 37 C.F.R. Sec _____ application and reexamination processing fees)

Charge any Additional Fees required under 37 C.F.R. Section 1.19 (Document supply fees)

Charge any Additional Fees required under 37 C.F.R. Section 1.21 (Miscellaneous fees and charges)

File Listing:

Document Number	Document Description	File Name	File Size(Bytes)/ Message Digest	Multi Part /.zip	Pages (if appl.)
1		35822-0P-2us_dec_poa.pdf	153032 ebbd47d716f1ee43d5c08d245535dce85950f0a5	yes	4
Multipart Description/PDF files in .zip description					
Document Description		Start	End		
Oath or Declaration filed		1	2		
Power of Attorney		3	4		
Warnings:					
Information:					
2	Application Data Sheet	35822-0P-2ADS_FORM.pdf	1031818 16e976fc5ba31785a08b4cd7f81a3944f0c525bb	no	5
Warnings:					
Information:					
3		35822_0P_2USF.pdf	3522356 01b473d3469538ec2fcdcd2dbba5c725b0a482e	yes	91
Multipart Description/PDF files in .zip description					
Document Description		Start	End		
Specification		1	72		
Claims		73	78		
Abstract		79	79		
Drawings-only black and white line drawings		80	91		
Warnings:					
Information:					
4	Information Disclosure Statement (IDS) Form (SB08)	35822-0P-2US_IDS_Form.pdf	612068 5687f73d844e5edae7e0e06c836b560b32de0de3	no	5
Warnings:					
Information:					

5	Fee Worksheet (SB06)	fee-info.pdf	36489	no	2
			35c5bf9fec3b8e482409ee0387102d61dcd1775		

Warnings:

Information:

Total Files Size (in bytes):	5355763
-------------------------------------	---------

This Acknowledgement Receipt evidences receipt on the noted date by the USPTO of the indicated documents, characterized by the applicant, and including page counts, where applicable. It serves as evidence of receipt similar to a Post Card, as described in MPEP 503.

New Applications Under 35 U.S.C. 111

If a new application is being filed and the application includes the necessary components for a filing date (see 37 CFR 1.53(b)-(d) and MPEP 506), a Filing Receipt (37 CFR 1.54) will be issued in due course and the date shown on this Acknowledgement Receipt will establish the filing date of the application.

National Stage of an International Application under 35 U.S.C. 371

If a timely submission to enter the national stage of an international application is compliant with the conditions of 35 U.S.C. 371 and other applicable requirements a Form PCT/DO/EO/903 indicating acceptance of the application as a national stage submission under 35 U.S.C. 371 will be issued in addition to the Filing Receipt, in due course.

New International Application Filed with the USPTO as a Receiving Office

If a new international application is being filed and the international application includes the necessary components for an international filing date (see PCT Article 11 and MPEP 1810), a Notification of the International Application Number and of the International Filing Date (Form PCT/RO/105) will be issued in due course, subject to prescriptions concerning national security, and the date shown on this Acknowledgement Receipt will establish the international filing date of the application.

Electronic Acknowledgement Receipt

EFS ID:	10456871
Application Number:	13176771
International Application Number:	
Confirmation Number:	5154
Title of Invention:	3D POINTING DEVICE AND METHOD FOR COMPENSATING ROTATIONS OF THE 3D POINTING DEVICE THEREOF
First Named Inventor/Applicant Name:	Zhou Ye
Customer Number:	31561
Filer:	Belinda Lee
Filer Authorized By:	
Attorney Docket Number:	35822-US-PA-0P-2
Receipt Date:	06-JUL-2011
Filing Date:	
Time Stamp:	07:33:18
Application Type:	Utility under 35 USC 111(a)

Payment information:

Submitted with Payment	yes
Payment Type	Credit Card
Payment was successfully received in RAM	\$514
RAM confirmation Number	7687
Deposit Account	502620
Authorized User	HUAI-LU,LEE-

The Director of the USPTO is hereby authorized to charge indicated fees and credit any overpayment as follows:

Charge any Additional Fees required under 37 C.F.R. Section 1.16 (National application filing, search, and examination fees)

Charge any Additional Fees required under 37 C.F.R. Section 205 (Patent application and reexamination processing fees)

Charge any Additional Fees required under 37 C.F.R. Section 1.19 (Document supply fees)

Charge any Additional Fees required under 37 C.F.R. Section 1.21 (Miscellaneous fees and charges)

File Listing:

Document Number	Document Description	File Name	File Size(Bytes)/ Message Digest	Multi Part /.zip	Pages (if appl.)	
1		35822-0P-2us_dec_poa.pdf	153032 ebbd47d716f1ee43d5c08d245535dce85950f0a5	yes	4	
Multipart Description/PDF files in .zip description						
		Document Description	Start	End		
		Oath or Declaration filed	1	2		
		Power of Attorney	3	4		
Warnings:						
Information:						
2	Application Data Sheet	35822-0P-2ADS_FORM.pdf	1031818 16e976fc5ba31785a08b4cd7f81a3944f0c525bb	no	5	
Warnings:						
Information:						
3		35822_0P_2USF.pdf	3522356 01b473d3469538ec2fcdcd2dbba5c725b0a482e	yes	91	
Multipart Description/PDF files in .zip description						
		Document Description	Start	End		
		Specification	1	72		
		Claims	73	78		
		Abstract	79	79		
		Drawings-only black and white line drawings	80	91		
Warnings:						
Information:						
4	Information Disclosure Statement (IDS) Form (SB08)	35822-0P-2US_IDS_Form.pdf	612068 5687f73d844e5edae7e0e06c836b560b32de0de3	no	5	
Warnings:						
Information:						

5	Fee Worksheet (SB06)	fee-info.pdf	36489 <small>35c5bf9fec3b8e482409ee0387102d61dcd1775</small>	no	2
---	----------------------	--------------	---	----	---

Warnings:

Information:

Total Files Size (in bytes):	5355763
-------------------------------------	---------

This Acknowledgement Receipt evidences receipt on the noted date by the USPTO of the indicated documents, characterized by the applicant, and including page counts, where applicable. It serves as evidence of receipt similar to a Post Card, as described in MPEP 503.

New Applications Under 35 U.S.C. 111

If a new application is being filed and the application includes the necessary components for a filing date (see 37 CFR 1.53(b)-(d) and MPEP 506), a Filing Receipt (37 CFR 1.54) will be issued in due course and the date shown on this Acknowledgement Receipt will establish the filing date of the application.

National Stage of an International Application under 35 U.S.C. 371

If a timely submission to enter the national stage of an international application is compliant with the conditions of 35 U.S.C. 371 and other applicable requirements a Form PCT/DO/EO/903 indicating acceptance of the application as a national stage submission under 35 U.S.C. 371 will be issued in addition to the Filing Receipt, in due course.

New International Application Filed with the USPTO as a Receiving Office

If a new international application is being filed and the international application includes the necessary components for an international filing date (see PCT Article 11 and MPEP 1810), a Notification of the International Application Number and of the International Filing Date (Form PCT/RO/105) will be issued in due course, subject to prescriptions concerning national security, and the date shown on this Acknowledgement Receipt will establish the international filing date of the application.

DECLARATION FOR UTILITY OR DESIGN PATENT APPLICATION

As the below named inventor, I hereby declare that:

My residence, post office address and citizenship are as stated below next to my name and that I believe I am an original, first and sole inventor (if only one name is listed below) or an original, first and joint inventor (if plural names are listed below) of the subject matter which is claimed and for which a design or Utility patent is sought on the invention entitled

3D POINTING DEVICE AND METHOD FOR COMPENSATING ROTATIONS OF THE 3D POINTING DEVICE THEREOF

the specification of which

is attached hereto.

was filed on _____

as Application Serial No. _____ and was amended on _____.

I hereby state that I have reviewed and understand the contents of the above-identified application, including the specification, claims and figures if any, as amended by any amendment referred to above.

I acknowledge the duty to disclose information which is material to the patentability of this application in accordance with Title 37, Code of Federal Regulations, §1.56.

I hereby claim foreign priority benefits under Title 35, United States Code, §119(a)-(d) or 365(b) of any foreign application(s) for patent or 365(a) of any PCT international application which designated at least one country other than the United States of America, or inventor's certificate listed on the Application Data Sheet, and have also identified on the Application Data Sheet any foreign application for patent or inventor's certificate having a filing date before that of each application on which priority is claimed:

I hereby claim the benefit under Title 35 U.S Code §119(e) of any U.S provisional applications listed on the Application Data Sheet.

I hereby claim the benefit under Title 35, United States Code §120 of any United States application(s) or PCT international application(s) designating The United States of America listed on the Application Data Sheet, and, insofar as the subject matter of each of the claims of this application is not disclosed in that/those prior application(s) in the manner provided by the first paragraph of Title 35, United States Code, §112, I acknowledge the duty to disclose information which is material to patentability as defined in Title 37, Code of Federal Regulation, §1.56 which become available between the filing date of the prior application(s) and the national or PCT international filing date of this application.

DECLARATION FOR UTILITY OR DESIGN PATENT APPLICATION

I hereby declare that all statements made herein of my own knowledge are true and that all statements made on information and belief are believed to be true; and further that these statements were made with the knowledge that willful false statements and the like so made are punishable by fine or imprisonment, or both, under Section 1001 of Title 18 of the United States Code and that such willful false statements may jeopardize the validity of the application or any design or utility patents issued thereon.

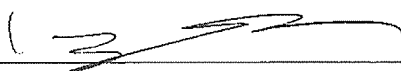
Signature:  Date: July. 5, 2011

Sole or First Joint Inventor: Zhou Ye

Citizenship: CN

Residence : CA, US

Post Office Address: 542 Hanbury Lane, Foster City, CA, US (94404)

Signature:  Date: 2011. 7. 5

Second Joint Inventor (if any): Chin-Lung Li

Citizenship: Taiwan, R.O.C.

Residence : Taoyuan County, Taiwan

Post Office Address: No.4, Ln. 99, Sec. 1, Shengde Rd., Zhongli City, Taoyuan County, Taiwan

Signature:  Date: 2011. 7. 5

Third Joint Inventor (if any): Shun-Nan Liou

Citizenship: Taiwan, R.O.C.

Residence : Kaohsiung City, Taiwan

Post Office Address: No. 28, Ln. 341, Gangshan N. St., Qianzhen Dist., Kaohsiung City, Taiwan