

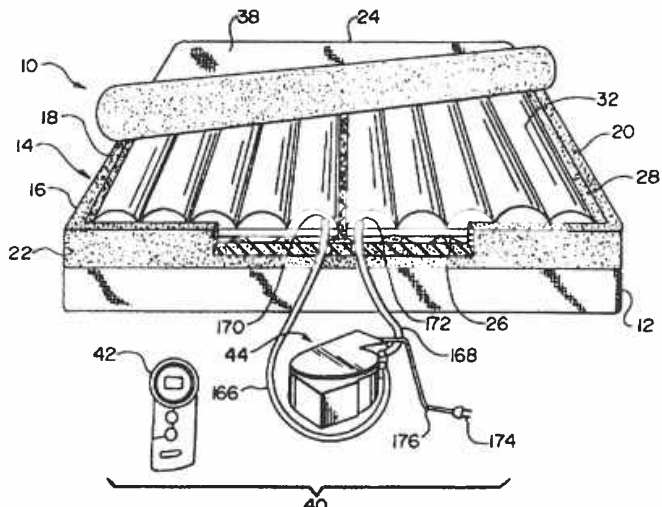

INTERNATIONAL APPLICATION PUBLISHED UNDER THE PATENT COOPERATION TREATY (PCT)

(51) International Patent Classification ⁶ : H04Q 7/06, A47C 27/10		A1	(11) International Publication Number: WO 96/13947
			(43) International Publication Date: 9 May 1996 (09.05.96)
(21) International Application Number: PCT/US95/14386		(81) Designated States: AL, AM, AT, AU, BB, BG, BR, BY, CA, CH, CN, CZ, DE, DK, EE, ES, FI, GB, GE, HU, JP, KE, KG, KP, KR, KZ, LK, LR, LT, LU, LV, MD, MG, MK, MN, MW, MX, NO, NZ, PL, PT, RO, RU, SD, SE, SI, SK, TJ, TT, UA, US, UZ, VN, European patent (AT, BE, CH, DE, DK, ES, FR, GB, GR, IE, IT, LU, MC, NL, PT, SE).	
(22) International Filing Date: 18 October 1995 (18.10.95)			
(30) Priority Data: 08/332,833 1 November 1994 (01.11.94) US 08/536,330 29 September 1995 (29.09.95) US		<p>Published With international search report. Before the expiration of the time limit for amending the claims and to be republished in the event of the receipt of amendments.</p>	
(71) Applicant (for all designated States except US): SELECT COMFORT CORPORATION [US/US]; 6105 Trenton Lane North, Minneapolis, MN 55442 (US).			
(72) Inventors; and (75) Inventors/Applicants (for US only): SHAFER, David, C. [-/US]; 216 Willow Road, Menlo Park, CA 94025 (US). DUVAL, Eugene, F. [-/US]; 2141 Camino A los Cerros, Menlo Park, CA 94025 (US).			
(74) Agents: PATTERSON, James, H. et al.; Patterson & Keough, P.A., 1200 Rand Tower, 527 Marquette Avenue South, Minneapolis, MN 55402 (US).			

(54) Title: IMPROVED AIR CONTROL SYSTEM FOR AN AIR BED



(57) Abstract

An automatic control system for controlling the firmness of a fluid supported mattress (14) of a bed assembly (10). The control system includes a motorized fluid pump, a control unit (44) for operating the pump to adjust the firmness of the air mattress (14), a hand held remote control unit (42) for actuating the control unit (44), and a transceiver system for transmitting information signals between the hand held unit (42) and the control unit (44). The air control system provides for independent control of both bladders (30, 32) in a two bladder air mattress (14) from a single unit (44), and allows a user to consistently set the firmness of each mattress air bladder (30, 32) to a desired value. The air control system includes an air pump specially designed to minimize transmission of motor noise into the environment.



FOR THE PURPOSES OF INFORMATION ONLY

Codes used to identify States party to the PCT on the front pages of pamphlets publishing international applications under the PCT.

AT	Austria	GB	United Kingdom	MR	Mauritania
AU	Australia	GE	Georgia	MW	Malawi
BB	Barbados	GN	Guinea	NE	Niger
BE	Belgium	GR	Greece	NL	Netherlands
BF	Burkina Faso	HU	Hungary	NO	Norway
BG	Bulgaria	IE	Ireland	NZ	New Zealand
BJ	Benin	IT	Italy	PL	Poland
BR	Brazil	JP	Japan	PT	Portugal
BY	Belarus	KE	Kenya	RO	Romania
CA	Canada	KG	Kyrgyzstan	RU	Russian Federation
CF	Central African Republic	KP	Democratic People's Republic of Korea	SD	Sudan
CG	Congo	KR	Republic of Korea	SE	Sweden
CH	Switzerland	KZ	Kazakhstan	SI	Slovenia
CI	Côte d'Ivoire	LI	Liechtenstein	SK	Slovakia
CM	Cameroon	LK	Sri Lanka	SN	Senegal
CN	China	LU	Luxembourg	TD	Chad
CS	Czechoslovakia	LV	Latvia	TG	Togo
CZ	Czech Republic	MC	Monaco	TJ	Tajikistan
DE	Germany	MD	Republic of Moldova	TT	Trinidad and Tobago
DK	Denmark	MG	Madagascar	UA	Ukraine
ES	Spain	ML	Mali	US	United States of America
FI	Finland	MN	Mongolia	UZ	Uzbekistan
FR	France			VN	Viet Nam
GA	Gabon				

AMERICAN NATIONAL MANUFACTURING, INC. - EX 1007 - Page 2

- 1 -

IMPROVED AIR CONTROL SYSTEM FOR AN AIR BEDTECHNICAL FIELD

This invention relates to improved methods and apparatus for attaining and regulating the fluid pressure in one or more fluid accommodating structures. More particularly, the invention relates to improved air pumps, controllers, information processing and hand controls for measuring and
5 varying the air pressure in an air mattress.

BACKGROUND OF THE INVENTION

Air supported mattresses are used with cots and beds to provide
10 yieldable body supports. The air mattresses can be inflated with hand operated pumps or bag pumps. Motor driven blowers and pumps have also been used more effectively to supply air under pressure to air mattresses. U.S. Patents 4,908,895 and 4,644,597, assigned to the assignee of the present invention, describe possible constructions of air mattresses.

AMERICAN NATIONAL MANUFACTURING, INC. - EX 1007 - Page 3

- 2 -

The air mattresses will typically sit within a border which supports the mattress such as that described in U.S. Patent 4,991,244, also assigned to the assignee of the present invention. Double, queen or king size beds can involve two air mattresses or two air chambers with individually adjustable air pressures.

5 These air chambers may be further divided internally with free fluid flow between these further divisions. The air mattresses can be equipped with a one-way air pressure relief valve operable to limit the air pressure in the air mattress to about 1 psig (pounds per square inch gauge, i.e., relative to ambient pressure) to prevent seam separation and blowout.

10 The biasing or firmness characteristics of an air mattress are determined by the pressure of the air in the air mattress. Control mechanisms have been used to adjust the inflation of air mattresses. Young et al. in U.S. Patent No. 4,224,706, for instance, disclose a mechanism for adjusting the amount of air in an air mattress. The mechanism disclosed in the '706 patent includes
15 one or more receptacles connected to air mattresses for supplying air to and receiving air from the air mattresses. These receptacles are located in the frame below the mattress. The internal volumes of the receptacles are changed by the rotation of a hand crank. The variation of the volume in the receptacles adjusts the pressure of the air in the air mattresses.

20 Other control systems for air mattresses have allowed operators to vary the air pressure within the mattress at the touch of a button. The hand control units in these systems were either located on the air tube connecting the pump to the mattress or the hand control units made an electrical connection to

AMERICAN NATIONAL MANUFACTURING, INC. - EX 1007 - Page 4

- 3 -

the pump and solenoid valves. See, for example, U.S. Patents 4,897,890, 4,829,616, 4,890,344, also assigned to the assignee of the present invention.

These hand control units typically allowed for the transmittance of two instructions to the pump/control unit. These instructions were either to
5 increase or to decrease the pressure. The users had to rely on their tactile senses in adjusting the air pressure because the units supplied no information to the user regarding the pressure in the mattress.

One previous design of pressure control for an air mattress involved keeping the air pressure constant at all times whether the user was on
10 the mattress or not. See U.S. Patent Nos. 5,142,717 and 4,995,124. A control unit allowed for a preset pressure to be set. One problem with this arrangement was the dramatic change in pressure at the time a user applied weight to the mattress. The air mattress had to have an internal structure to support much of the users weight in order to prevent the escape of large volumes of air while regulating the
15 pressure at the previously set value. The internal structure interfered with the comfort advantages of having an air supported mattress.

Another design of a pressure control unit provided a digital display of the internal pressure and push buttons. See U.S. Patent No. 5,020,176. The user could either use a constant pressure mode where the pressure could be set by
20 the user. The user also had the option of using a manual mode where the pressure was not kept constant but where the user directly controlled the flow of fluid into or out from the mattress.

In these previous designs, if the bed contained two separate

Explore Litigation Insights

Docket Alarm provides insights to develop a more informed litigation strategy and the peace of mind of knowing you're on top of things.

Real-Time Litigation Alerts



Keep your litigation team up-to-date with **real-time alerts** and advanced team management tools built for the enterprise, all while greatly reducing PACER spend.

Our comprehensive service means we can handle Federal, State, and Administrative courts across the country.

Advanced Docket Research



With over 230 million records, Docket Alarm's cloud-native docket research platform finds what other services can't. Coverage includes Federal, State, plus PTAB, TTAB, ITC and NLRB decisions, all in one place.

Identify arguments that have been successful in the past with full text, pinpoint searching. Link to case law cited within any court document via Fastcase.

Analytics At Your Fingertips



Learn what happened the last time a particular judge, opposing counsel or company faced cases similar to yours.

Advanced out-of-the-box PTAB and TTAB analytics are always at your fingertips.

API

Docket Alarm offers a powerful API (application programming interface) to developers that want to integrate case filings into their apps.

LAW FIRMS

Build custom dashboards for your attorneys and clients with live data direct from the court.

Automate many repetitive legal tasks like conflict checks, document management, and marketing.

FINANCIAL INSTITUTIONS

Litigation and bankruptcy checks for companies and debtors.

E-DISCOVERY AND LEGAL VENDORS

Sync your system to PACER to automate legal marketing.