

[54] **CONTROL SYSTEM FOR FLUID-FILLED BEDS**

[75] **Inventor:** Derek P. Dotson, Thousand Oaks, Calif.

[73] **Assignee:** Angel Echevarria Co., Inc., Los Angeles, Calif.

[21] **Appl. No.:** 424,863

[22] **Filed:** Oct. 20, 1989

[51] **Int. Cl.⁵** F16K 31/12; A47C 21/08

[52] **U.S. Cl.** 5/453; 5/455; 137/487.5; 417/38

[58] **Field of Search** 5/453, 456, 449, 454, 5/455; 137/487.5; 297/DIG. 3; 417/18, 20, 38

[56] **References Cited**

U.S. PATENT DOCUMENTS

4,297,755	11/1981	Mollura	5/453
4,394,784	7/1983	Swenson	5/455
4,435,864	3/1984	Callaway	5/453
4,634,179	1/1987	Hashimoto	297/DIG. 3
4,720,807	1/1988	Ferran	137/487.5

4,803,744	2/1989	Peck	5/453
4,829,616	5/1989	Walker	5/449
4,838,309	6/1989	Goodwin	5/456
4,873,737	10/1989	Savenije	5/455

Primary Examiner—Gary L. Smith
Assistant Examiner—F. Saether
Attorney, Agent, or Firm—Henry M. Bissell

[57] **ABSTRACT**

A system for automatically controlling the pressure maintained in a plurality of fluid-filled cylinders supporting a sleep surface in order to maintain a desired degree of firmness/softness. In one mode, the system permits the user to set the desired level of firmness and then the system acts to maintain that level under the conditions encountered in use, either venting if an above-setting pressure is sensed or pumping to fill if a below-setting pressure is detected. In another mode, the user is enabled to manually activate either the pump or the vent in order to vary the firmness to his choice.

21 Claims, 3 Drawing Sheets

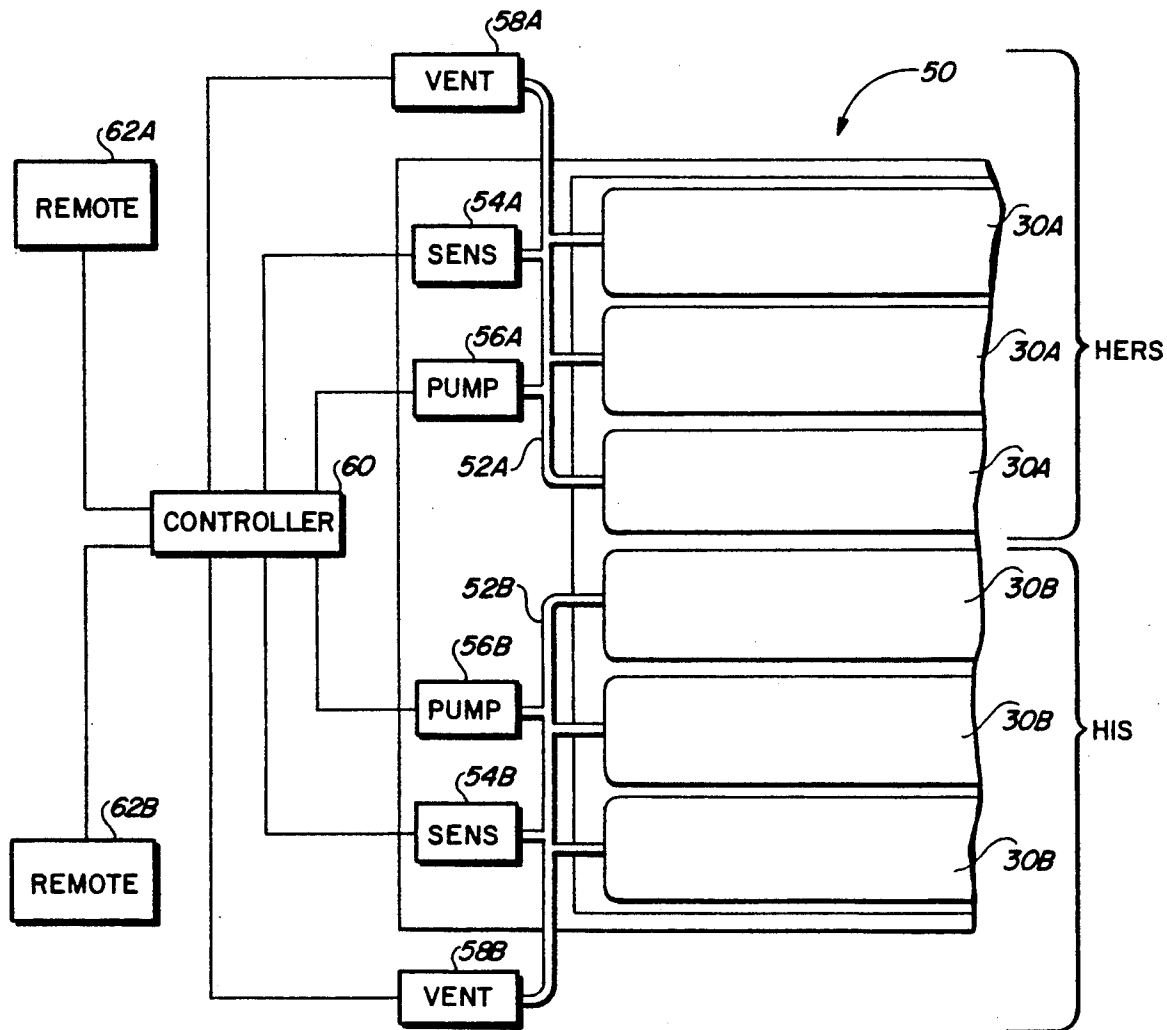

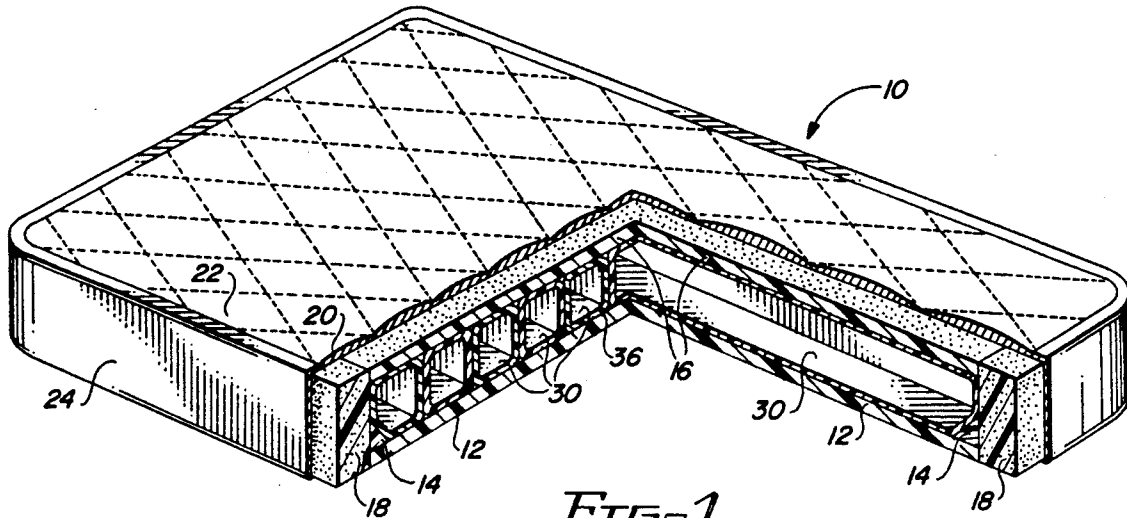

FIG. 1
(PRIOR ART)

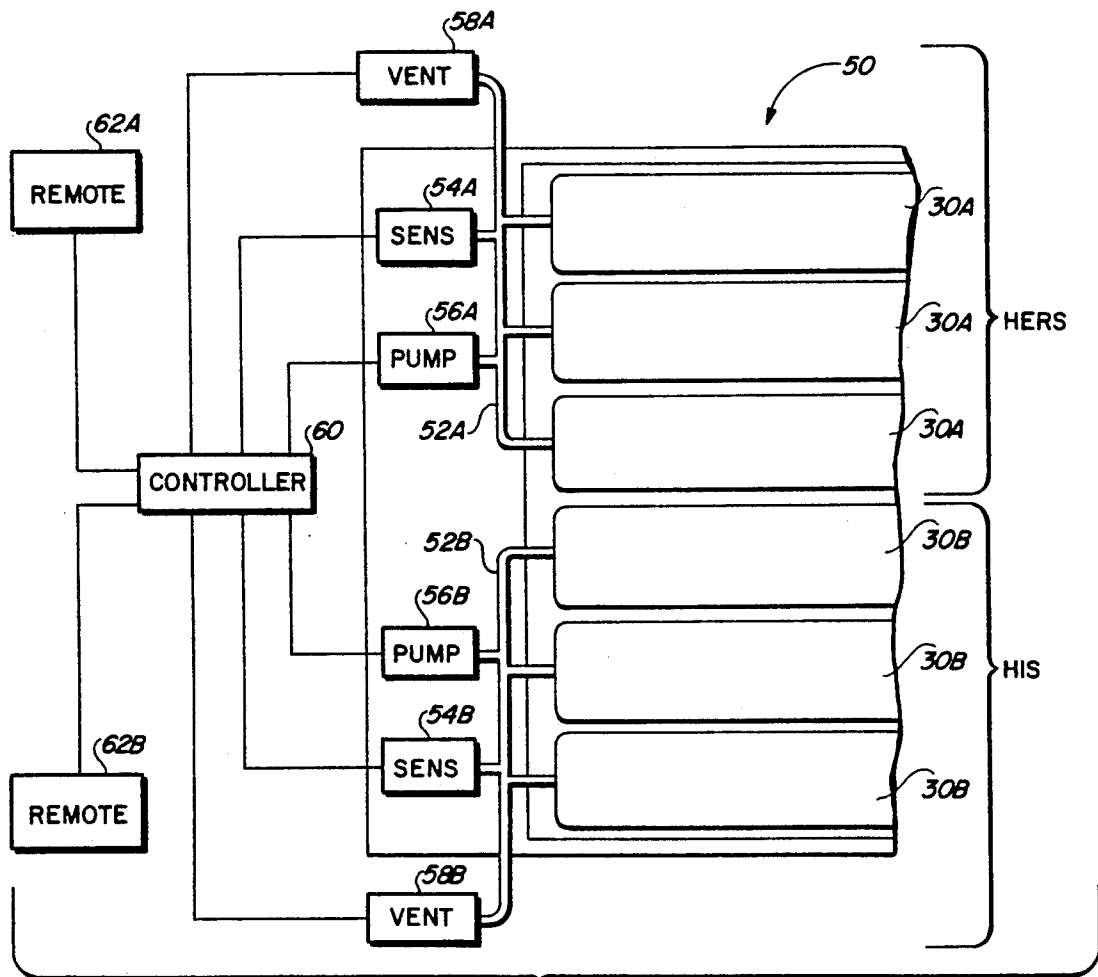
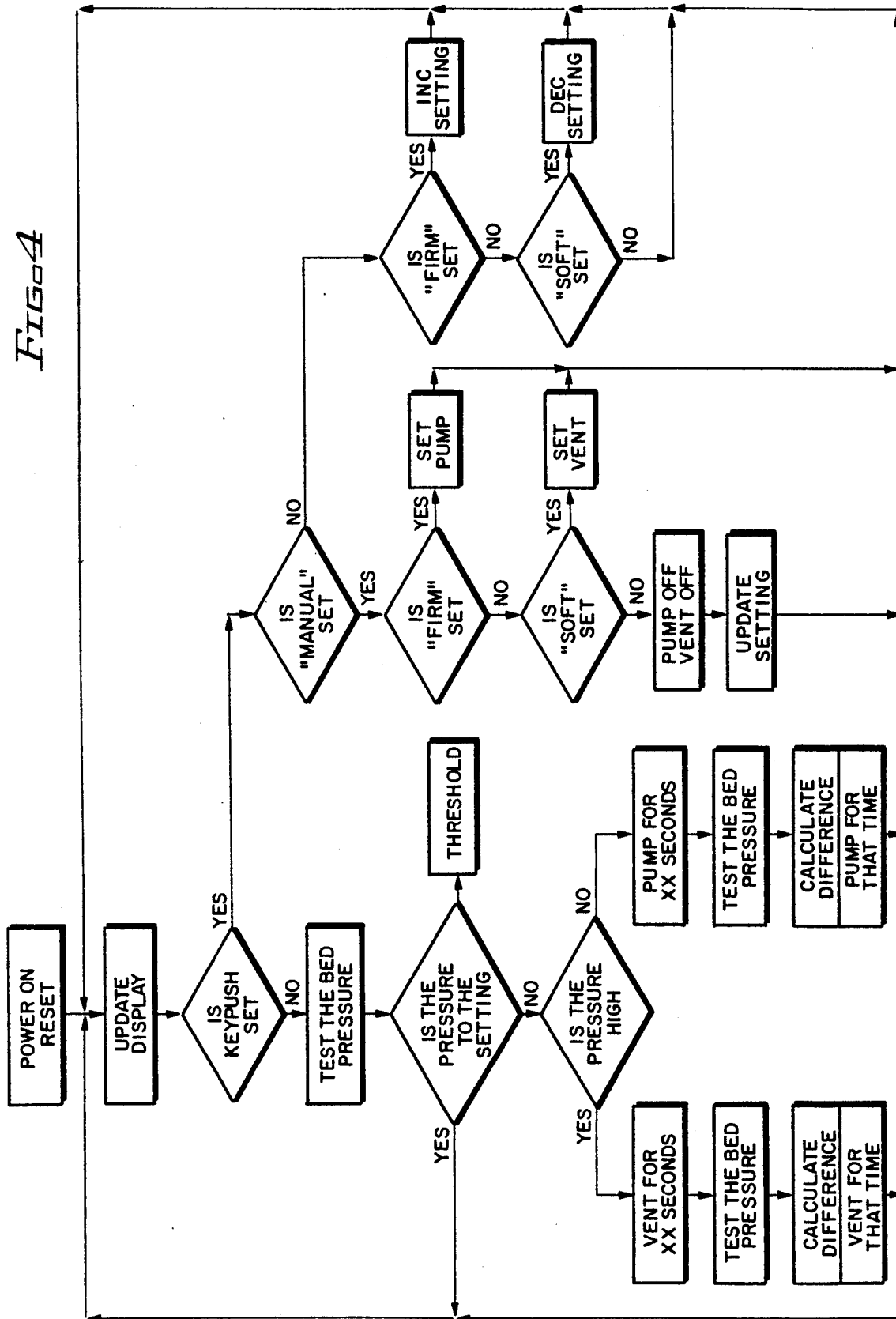
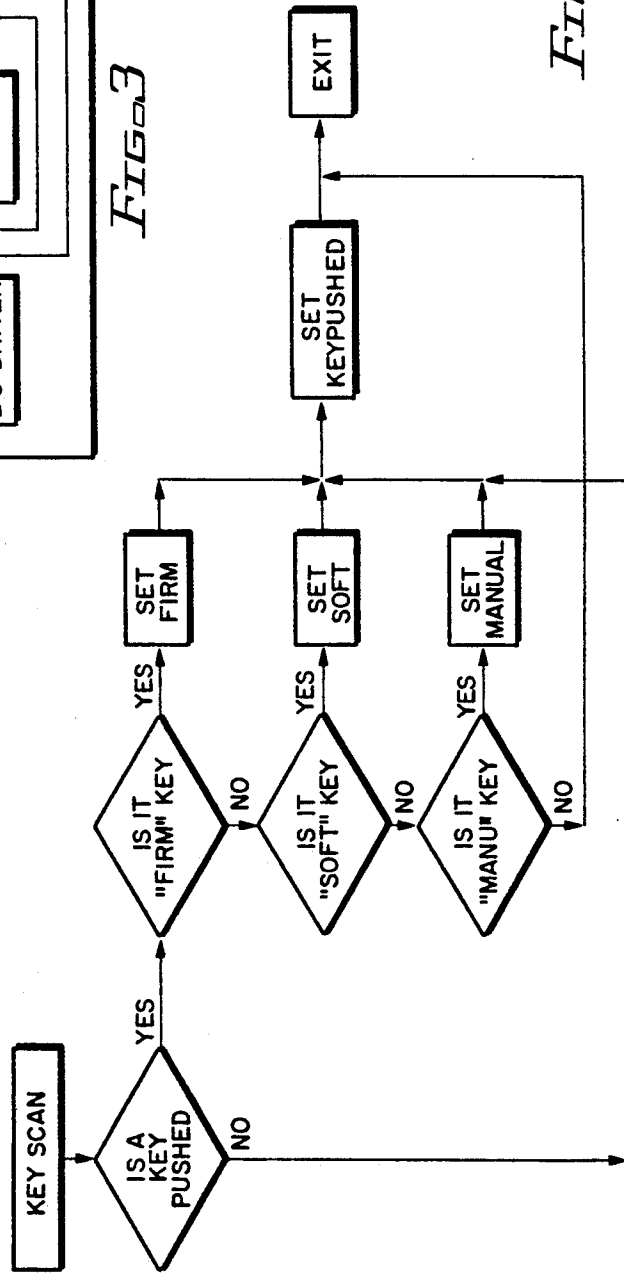
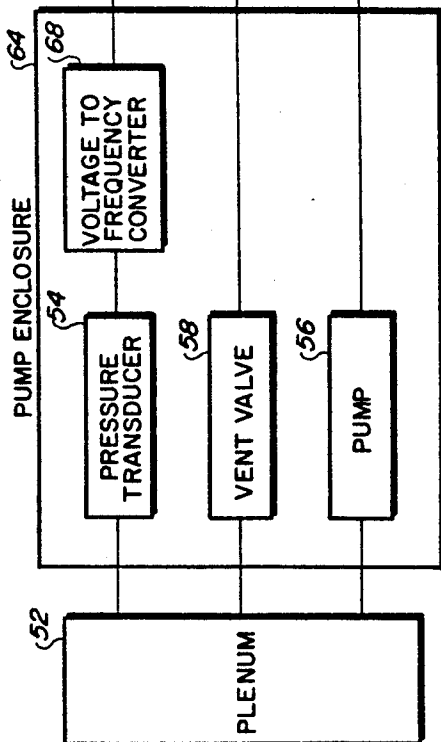
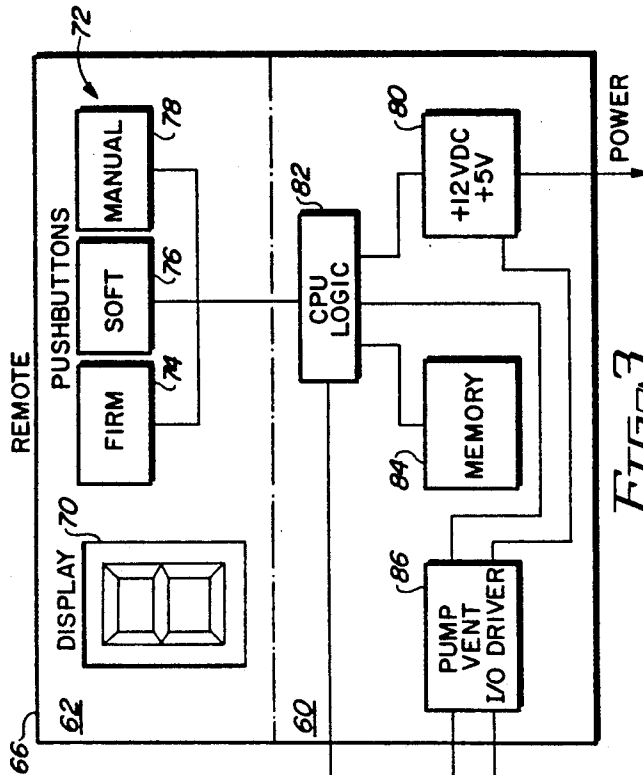

FIG. 2

FIG 4





CONTROL SYSTEM FOR FLUID-FILLED BEDS

BACKGROUND OF THE INVENTION

1. Field of the Invention

The present invention generally relates to fluid-filled beds, such as water beds or inflated tube mattresses, and more particularly relates to an automatic control system for such beds.

2. Description of the Related Art

Beds and mattresses, sometimes referred to as sleep surfaces, have long been an important item of furniture in homes, temporary lodgings, or wherever people go when in need of sleep. On the average, a person spends about one-third (eight hours, more or less, of each twenty-four hour interval) of his life in bed. Clearly, the degree of comfort provided by one's bed is important to the user.

Various factors contribute to or detract from the comfort of a bed: the surface "terrain", whether smooth or lumpy; the degree of firmness; the type and uniformity of support over the sleep surface; etc. An uncomfortable bed may interfere with sleep by keeping a person from going to sleep readily or by causing the person to sleep fitfully during the night. Even a bed that is not noticeably uncomfortable may still cause the user to awake in the morning with certain aches and pains, stiffness or the like as a result of an unsatisfactory sleep surface.

Until the introduction of coil springs, improvements in the designs of beds were directed more to their shapes and configurations, such as their use of paneling with posts supporting a canopy, etc., than to the degree of comfort afforded the occupants. With the development of coil springs, which were first fitted into mattresses in the early 19th century, bed comfort was transformed. Over the next 150 years or so, beds evolved into the general form in common use today, generally a metal frame supporting a spring structure on which a mattress, which may also incorporate springs, a foam or similar support or a combination of the two, is placed.

With 150 years of development, the current coil spring bed with an inner spring mattress has about reached the pinnacle of its design. Current innovation in the development of beds and mattresses involves the use of fluid supported sleep surfaces. The waterbed, as it was known, which became a minor fad about a generation ago, was in its simplest form merely a plastic sack or bag which was filled with water. It was noted for its "wave action", which contributed to new sleep sensations; for its substantial weight because of the volume of water involved; and for its tendency to develop leaks. These two latter aspects gave the term "water bed" an unpleasant connotation, particularly with landlords whose rented apartments were sometimes damaged by tenants' water beds.

The problems with waterbeds of the single cell type have been largely overcome by the substitution of a plurality of water filled cylindrical containers as support members. These are typically arrayed side by side in a central cavity in the bed structure. Since each container only holds about thirty pounds of water, they can be manipulated much more readily, and a leak in one container is not disastrous because the volume which is involved is much less; also, a waterproof liner in the cavity is adequate to contain water from a leaking cylinder. The multi-cell configuration provides one outstanding advantage, in addition to eliminating the wave

action of the "water bag", in that it is possible to vary the firmness of the sleep surface from one side of the bed to the other, simply by adjusting the degree to which the individual cylinders are filled with water.

Most recently, advances in bed design have been directed to achieving the capability of adjusting the degree of firmness of support automatically at different points of the sleep surface by using a settable control, much like the temperature of two sides of an electric blanket can be individually adjusted by setting a rheostat in a control system which includes sensors capable of monitoring temperature or some analog thereof. A feature such as the automatic control of the degree of support of the sleep surface with maintenance of the apparent firmness at a present level, selectable by the user, regardless of the load on the sleep surface, is a highly desirable attribute in a bed where sleep comfort is important to the user. It is also desirable from the standpoint of salability of the product, since it is a feature that provides a favorable comparison with other types of beds which are incapable of providing such a feature.

Accordingly, it is a general object of the present invention to provide a system for a fluid supported bed which allows selection of a setting which is variable over a range of firmness levels. It is a further object of the present invention to provide such a system which has the capability of automatically adjusting the degree of support to accord to the preset firmness level as the load on the sleep surface changes, as when a person moves around on the sleep surface or gets on or off the bed.

SUMMARY OF THE INVENTION

In brief, arrangements in accordance with the present invention comprise a fluid pump coupled to pressurize the plurality of chambers of a fluid flotation bed. Associated with the pump is a controller which includes a venting device, sensors for monitoring the firmness level of the sleep surface as determined by the pressurized cylinders, selection and display elements for interfacing with the user, and a special purpose computer for activating the pump and venting valve in response to sensor signals, relative to the predetermined settings of the selection element.

In one particular arrangement in accordance with the invention which is specifically adapted for pneumatic operation, the pump is an air pump and the vent valve is arranged to vent to atmosphere. Moreover, where the plurality of cylinders is organized in two sets so that the firmness of the sleep surface may be separately determined for the two opposite sides of the bed, the cylinders are connected by sets to corresponding individual plenum chambers, each of which is separately associated with venting and pumping means. Separate sensors are provided for the two independent systems and dual channels are incorporated in the computer to provide independent control of the two sets of cylinders. Alternatively, the sensing and control of respective pressures in the individual sets of cylinders may be conducted on a time multiplex basis with the computer being switched alternately between the sensors and selectors of the respective systems and valving being activated to connect the vent and/or pump to the particular system calling for venting or pumping at a given time.

In accordance with one particular aspect of the invention, the controller operates on a repetitive cycle,

Explore Litigation Insights

Docket Alarm provides insights to develop a more informed litigation strategy and the peace of mind of knowing you're on top of things.

Real-Time Litigation Alerts



Keep your litigation team up-to-date with **real-time alerts** and advanced team management tools built for the enterprise, all while greatly reducing PACER spend.

Our comprehensive service means we can handle Federal, State, and Administrative courts across the country.

Advanced Docket Research



With over 230 million records, Docket Alarm's cloud-native docket research platform finds what other services can't. Coverage includes Federal, State, plus PTAB, TTAB, ITC and NLRB decisions, all in one place.

Identify arguments that have been successful in the past with full text, pinpoint searching. Link to case law cited within any court document via Fastcase.

Analytics At Your Fingertips



Learn what happened the last time a particular judge, opposing counsel or company faced cases similar to yours.

Advanced out-of-the-box PTAB and TTAB analytics are always at your fingertips.

API

Docket Alarm offers a powerful API (application programming interface) to developers that want to integrate case filings into their apps.

LAW FIRMS

Build custom dashboards for your attorneys and clients with live data direct from the court.

Automate many repetitive legal tasks like conflict checks, document management, and marketing.

FINANCIAL INSTITUTIONS

Litigation and bankruptcy checks for companies and debtors.

E-DISCOVERY AND LEGAL VENDORS

Sync your system to PACER to automate legal marketing.