



US 20120078374A1

(19) **United States**

(12) **Patent Application Publication**
Villiers et al.

(10) **Pub. No.: US 2012/0078374 A1**

(43) **Pub. Date: Mar. 29, 2012**

(54) **SPINAL MIDLINE INDICATOR**

(30) **Foreign Application Priority Data**

(75) Inventors: **Malan De Villiers**, Wapadrand (ZA); **Ulrich Reinhard Hähnle**, Saxonwold (ZA)

Jan. 31, 2003 (ZA) 2003/0874

Publication Classification

(73) Assignee: **SpinalMotion, Inc.**, Mountain View, CA (US)

(51) **Int. Cl.**
A61F 2/44 (2006.01)

(52) **U.S. Cl.** **623/17.16**

(21) Appl. No.: **13/310,514**

(57) **ABSTRACT**

(22) Filed: **Dec. 2, 2011**

Related U.S. Application Data

(63) Continuation of application No. 12/616,697, filed on Nov. 11, 2009, now Pat. No. 8,090,428, which is a continuation of application No. 11/187,733, filed on Jul. 21, 2005, now Pat. No. 7,637,913, which is a continuation of application No. PCT/IB2004/000170, filed on Jan. 26, 2004.

A spinal midline indicator (10) has a body (14) of radiolucent material for insertion between adjacent vertebrae (18, 20) and a radiographic marker (12) located centrally with the body to indicate the position of the spinal midline (22) in anterior-posterior images when the body is centrally located between the vertebrae. The radiographic marker is typically an elongate metal handle. The body may carry secondary radiographic markers (16) on opposite sides of and equidistant from the handle so that the handle indicates the position of the spinal midline when the body is placed centrally between the vertebrae.

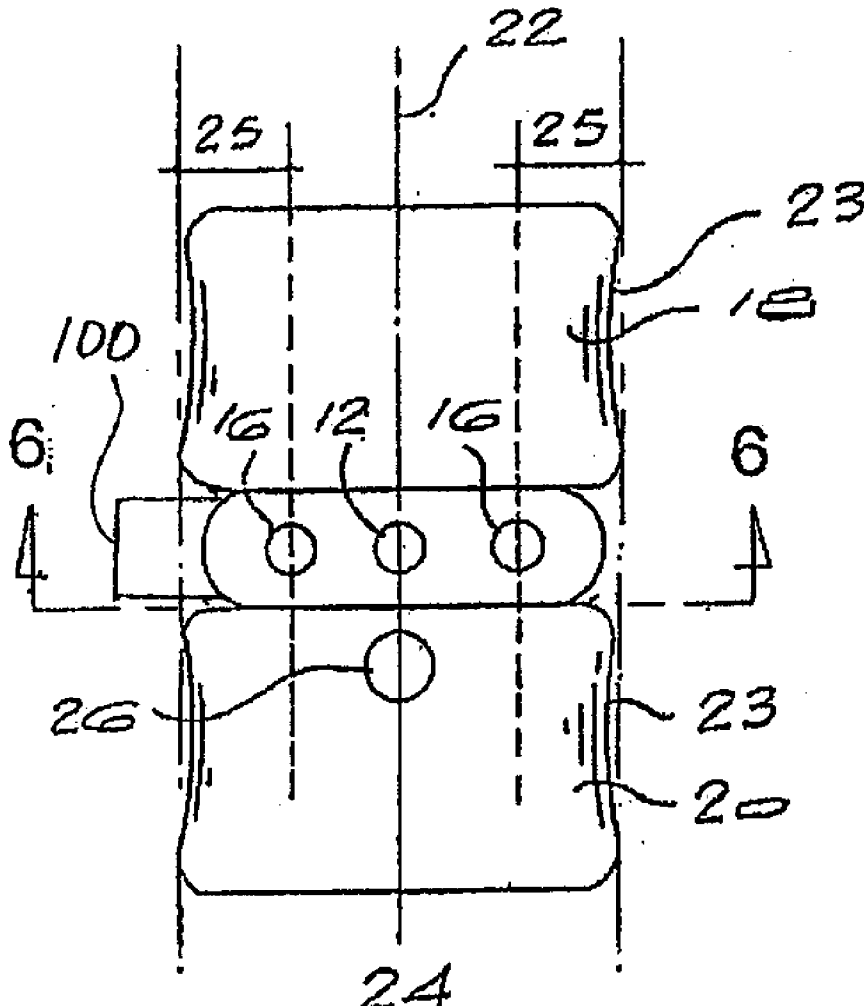

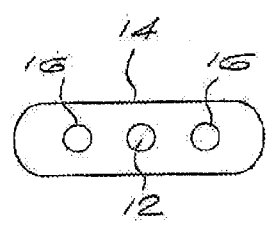
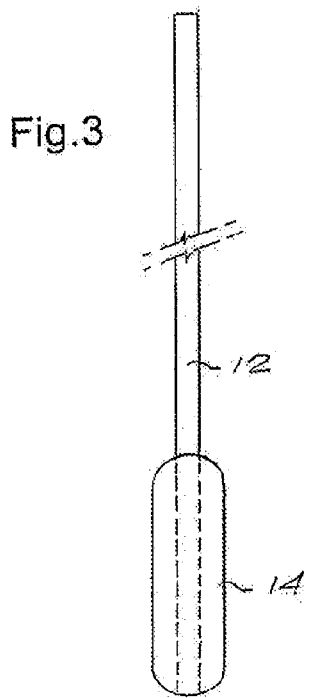
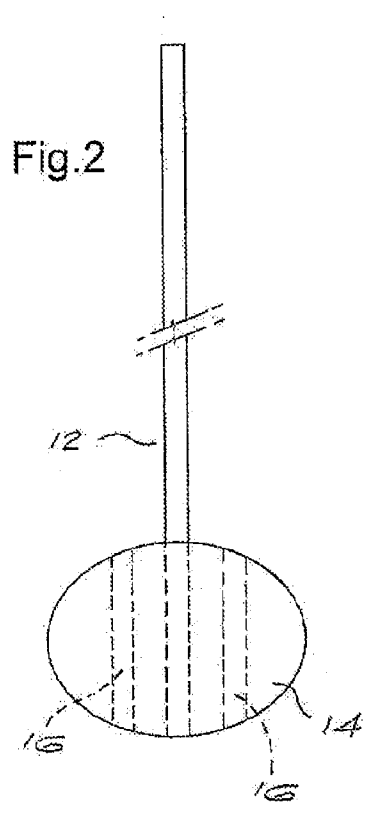
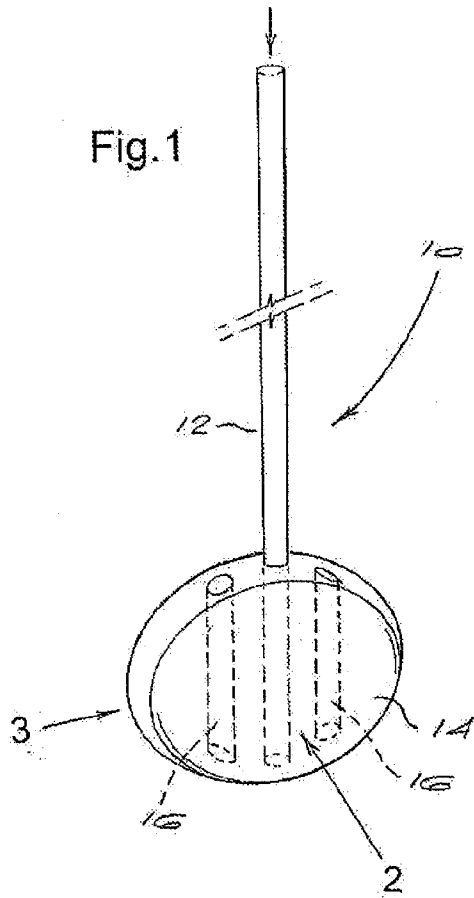

Fig.5

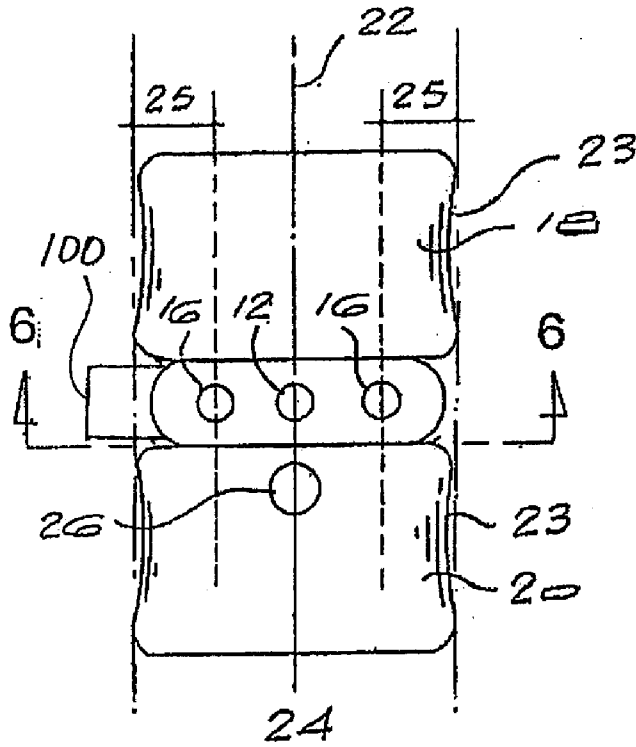
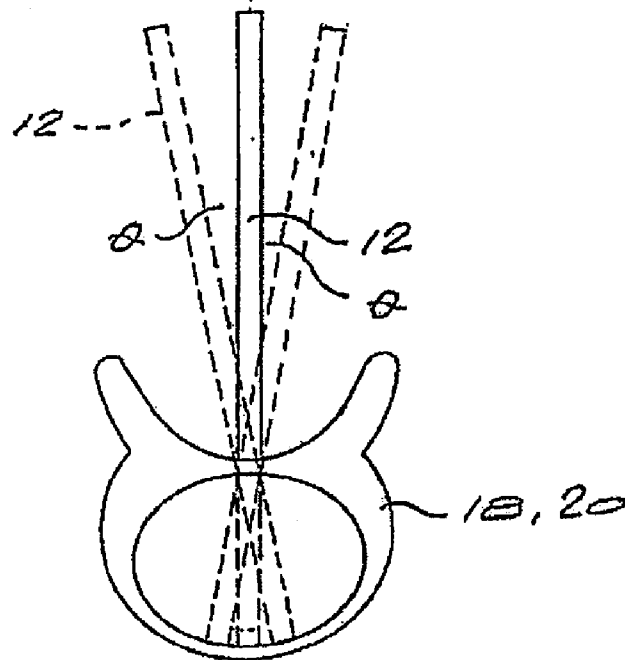

Fig.6



SPINAL MIDLINE INDICATOR

CROSS-REFERENCES TO RELATED APPLICATIONS

[0001] This application is a continuation of U.S. patent application Ser. No. 12/616,697 (Attorney Docket No. 29850-705.302), filed Nov. 11, 2009, which is a continuation of U.S. patent application Ser. No. 11/187,733 (Attorney Docket No. 29850-705.301), filed Jul. 21, 2005, which is a continuation of International Application PCT/IB2004/000170 (Attorney Docket No. 29850-705.601), filed Jan. 26, 2004, which claims the benefit of South African Application No. 2003/0874 (Attorney Docket No. 29850-705.841), filed Jan. 31, 2003, the full disclosures of which are incorporated herein by reference.

BACKGROUND OF THE INVENTION

[0002] This invention relates to a spinal midline indicator.

[0003] It is important for a surgeon performing an ALIF (anterior lumbar interbody fusion) or ACIF (anterior cervical interbody fusion) cage or spinal disc replacement procedure to be able accurately to establish the centre- or midline of the spine. It is only once the surgeon has correctly established the position of the spinal midline that he is able to place the cage or spinal disc accurately on that midline. Off-centre placement will result in eccentric loading and possible early failure or accelerated wear.

[0004] At present, surgeons attempt to establish the spinal midline by visual inspection of an A-P (anterior-posterior) image. However this is often inaccurate, and can lead to subsequent off-centre placement of the cage or disc with potential disadvantages as described above.

[0005] The present invention seeks to provide an instrument which will facilitate accurate establishment of the spinal midline.

BRIEF SUMMARY OF THE INVENTION

[0006] According to the present invention there is provided a spinal midline indicator comprising a body of radiolucent material for insertion between adjacent vertebrae and a radiographic marker associated centrally with the body to indicate, in an anterior-posterior radiographic image, the position of the spinal midline when the body is appropriately located between the vertebrae. Conveniently the radiographic marker is an elongate handle which is connected to the body to facilitate placement of the body between the vertebrae and which is made of a radiographic material, i.e., a material which is substantially opaque to radiographic (fluoroscopic) imaging.

[0007] In the preferred embodiment, the body carries, in addition to the handle which serves as a first radiographic marker, two or more secondary radiographic markers on opposite sides of and equidistant from the first marker, whereby the first marker indicates the position of the spinal midline when the body is placed centrally between the vertebrae and the secondary markers are seen in the radiographic image to be equidistant from lateral edges of the vertebrae.

[0008] Further according to the invention there is provided a method of identifying a spinal midline which comprises the steps of inserting the body of a spinal midline indicator as summarized above between adjacent spinal vertebrae,

the position of the radiographic marker as a guide, applying a marking, eg. a pin, to a vertebra to indicate the midline.

[0009] Other features of the invention are set forth in the appended claims.

BRIEF DESCRIPTION OF THE DRAWINGS

[0010] The invention will now be described in more detail, by way of example only, with reference to the accompanying drawings.

[0011] FIG. 1 shows a perspective view of a spinal midline indicator according to the invention;

[0012] FIG. 2 shows a side view of the indicator in the direction of the arrow 2 in FIG. 1;

[0013] FIG. 3 shows a side view of the indicator in the direction of the arrow 3 in FIG. 1;

[0014] FIG. 4 shows an end view of the indicator in the direction of the arrow 4 in FIG. 1;

[0015] FIG. 5 diagrammatically illustrates the indicator in use; and

[0016] FIG. 6 shows a diagrammatic cross-section at the line 6-6 in FIG. 5.

DETAILED DESCRIPTION OF THE INVENTION

[0017] The spinal midline indicator 10 seen in FIGS. 1 to 4 includes an elongate handle 12 and a body 14 carried centrally at one end of the handle. The handle is made of a radiographic material, i.e. one which is opaque to radiation in the radio-wave part of the spectrum, including X-radiation. The handle may, for instance, be made of stainless steel or titanium. The handle 12 extends substantially through the body 14. The body 14 is made of a radiolucent material, i.e. one which is at least to some degree transparent to the radiation. The body may, for instance, be made of PEEK (polyetheretherketone) or UHMWPE (ultra-high molecular weight polyethylene).

[0018] Embedded in the body 14 are two elongate markers 16, also of radiographic material such as stainless steel or titanium. The markers 16 are aligned parallel to the handle 12 and are located on opposite sides of, and equidistant from the handle.

[0019] FIG. 5 diagrammatically illustrates, in an anterior view, adjacent upper and lower vertebrae 18 and 20 respectively. As explained above it is important, during an ALIF or ACIF cage or spinal disc replacement procedure carried out anteriorly, for the surgeon to be able accurately to establish the spinal midline, indicated by the line 22, since it is centrally on this line that the replacement disc or cage must be placed. The procedure is typically carried out, with the patient lying prone and flat on his back, through a frontal incision.

[0020] In order to establish the midline 22, the surgeon aligns the handle 12 at a vertical orientation and uses it to insert the body 14 between the vertebrae 18 and 20. It will be understood that a separate instrument 100 is used to hold the vertebrae apart for this insertion to take place. An attempt is made to orientate the body centrally with the handle 12 vertical, thereby to ensure that the handle correctly indicates the midline 22.

[0021] An X-ray photograph or radiographic image is taken in the vertical anterior-posterior direction. In this radiographic image the handle 12, markers 16 and vertebrae 18, 20 will be visible. By ensuring that the markers 16 are equidistantly laterally spaced from the osseous edges 23 of the ver-

trally positioned. It will be understood that during this procedure, the handle **12** itself operates as a radiographic marker indicating a central position.

[0022] It will also be understood that if the handle **12** and markers **16** are aligned with the anterior-posterior direction in which the radiographic image is taken, they will appear in the radiographic image merely as dots of small lateral dimension. However if the handle is not perfectly aligned in the anterior-posterior, i.e. vertical direction, parallax effects will result in the handle and markers being seen as lines rather than dots.

[0023] This is illustrated in FIG. **6** in which the full lines show the handle **10** at the correct anterior-posterior or vertical orientation and the broken lines show it at orientations in which it is misaligned by an angle **9**. It will be understood that in a radiographic image in the anterior-posterior direction indicated by the arrow **24**, the handle **12** and markers **16** will appear as dots at the full line orientation but as short lines at the broken line orientations.

[0024] By consulting radiographic images and manipulating the indicator **10** as necessary in response to the information derived therefrom, the surgeon can ensure that the indicator is at the correct position and orientation. When the

indicator is in the correct position and at the correct orientation, the handle **12** will lie in a vertical plane containing the midline **22**. The surgeon can now use the handle as a positive indicator of that midline. The position of the radiographic marker can be used as a guide to apply a marking to a vertebra to indicate the midline. He can accurately mark the midline, for instance by knocking a pin **26** into one of the vertebrae.

[0025] Once the midline has been marked on one or both of the vertebrae, the indicator **10** is no longer required and can be removed for later re-use. The marker(s) then serve to indicate the midline **22** to enable subsequent, accurate positioning of the relevant prosthesis to take place.

What is claimed is:

1. A spinal midline indicator comprising:

- a body of radiolucent material sized and shaped to fit into an intervertebral space between two adjacent vertebrae; and
- a radiographic marker formed as an elongated handle attached to and extending from the body along a central axis of the body in an anterior-posterior direction, wherein the handle is embedded in the body.

* * * * *