

[54] **SYSTEM AND METHOD FOR TESTING ANALOG TO DIGITAL CONVERTER EMBEDDED IN MICROCONTROLLER**

[75] **Inventor:** Ram S. Bobba, San Jose, Calif.
 [73] **Assignee:** National Semiconductor Corporation, Santa Clara, Calif.

[21] **Appl. No.:** 532,606
 [22] **Filed:** Jun. 4, 1990

[51] **Int. Cl.⁵** H03M 1/10; G06F 11/00
 [52] **U.S. Cl.** 341/120; 371/27; 324/73.1; 364/571.01; 364/553
 [58] **Field of Search** 341/120, 131, 139; 371/25.1, 27, 24, 26, 15.1, 16.1; 324/73.1; 364/553, 571.02, 571.07, 571.01, 550

[56] **References Cited**
U.S. PATENT DOCUMENTS

4,354,177	10/1982	Sloane	341/120
4,539,683	9/1985	Hahn et al.	341/120
4,700,174	10/1987	Sutherland et al.	341/120
4,816,750	3/1989	Van Der Kloot et al.	324/73.1
4,896,282	1/1990	Orwell	341/120 X

Primary Examiner—A. D. Pellinen
Assistant Examiner—Sharon D. Logan
Attorney, Agent, or Firm—Flehr, Hohbach, Test, Albritton & Herbert

[57] **ABSTRACT**

A tester system tests the transfer characteristics and operability of an analog to digital converter (ADC) embedded in a microprocessor. The tester generates a sequence of analog signal test values, and prompts the microprocessor to read and convert each test value. The microprocessor sets up a table in its internal memory, the table having one tally value for every possible code output by the embedded ADC. After the embedded ADC converts each test value, the microprocessor reads the digital value output by the embedded ADC and increments a corresponding tally value in its internally stored table. When the sequence of tests is completed, the microprocessor transmits the entire table of tally values to the tester. The tester then performs a well known set of calculations on the tally data to determine the transfer characteristics and operability of the embedded ADC. By performing all tally operations in the microprocessor under test, the test sequence can be performed much more quickly than if each converted value were separately transmitted by the microprocessor to the tester. In addition, the tallying operation of the microprocessor simulates normal operation of the microprocessor while performing analog to digital conversions, and thus the embedded ADC is subjected to electromagnetic noise characteristic of the microprocessor under normal operation.

16 Claims, 2 Drawing Sheets

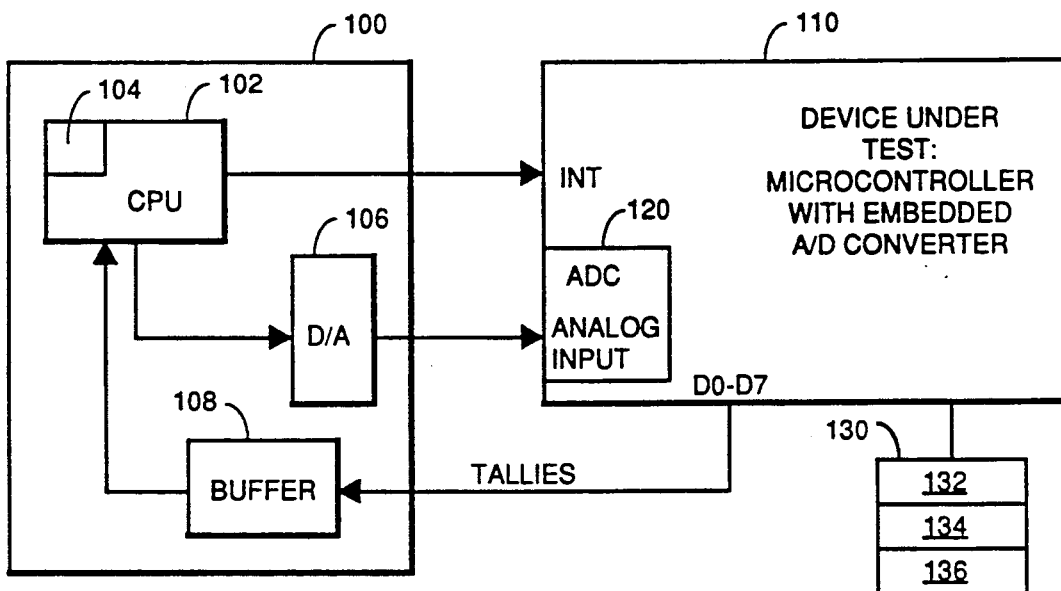

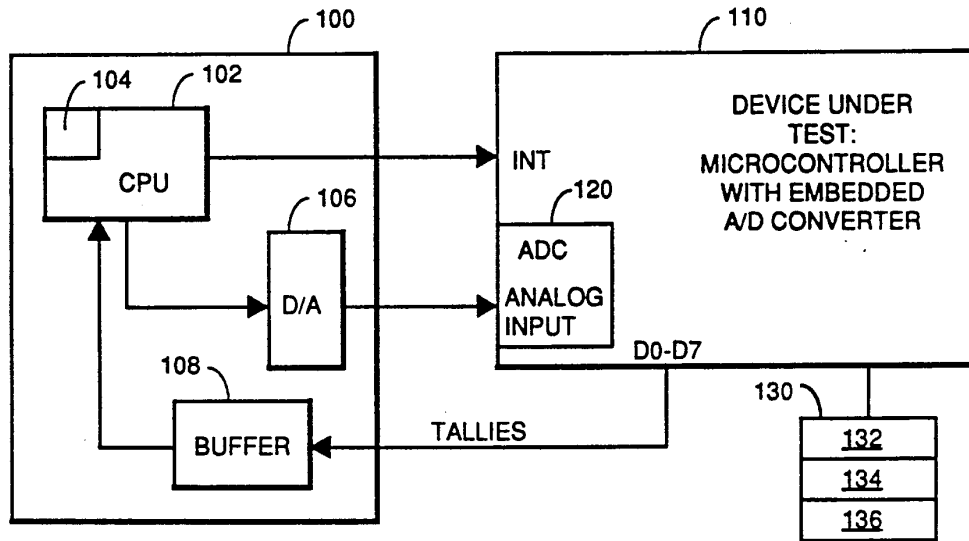

FIGURE 1

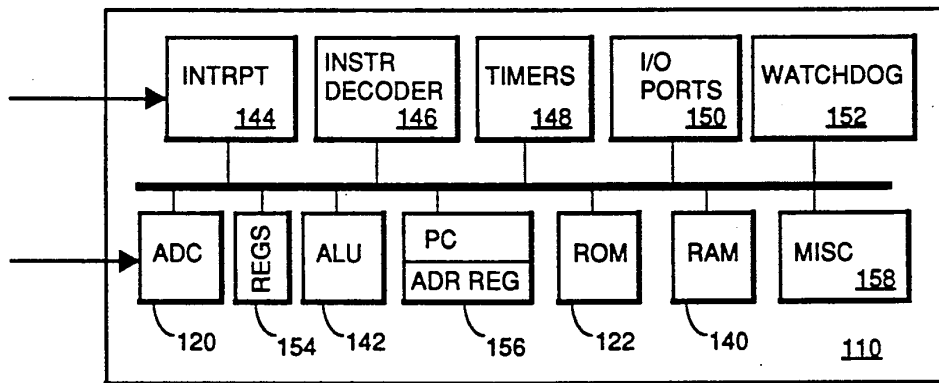

FIGURE 2

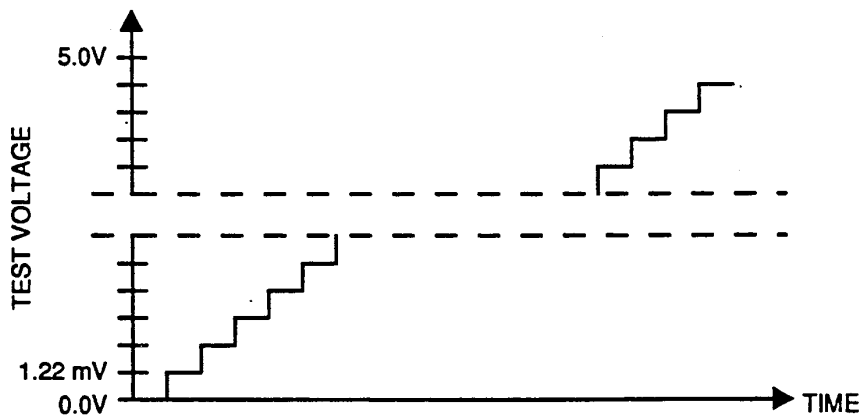

FIGURE 3

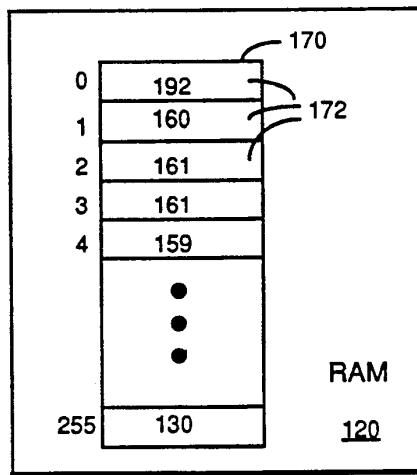

FIGURE 4

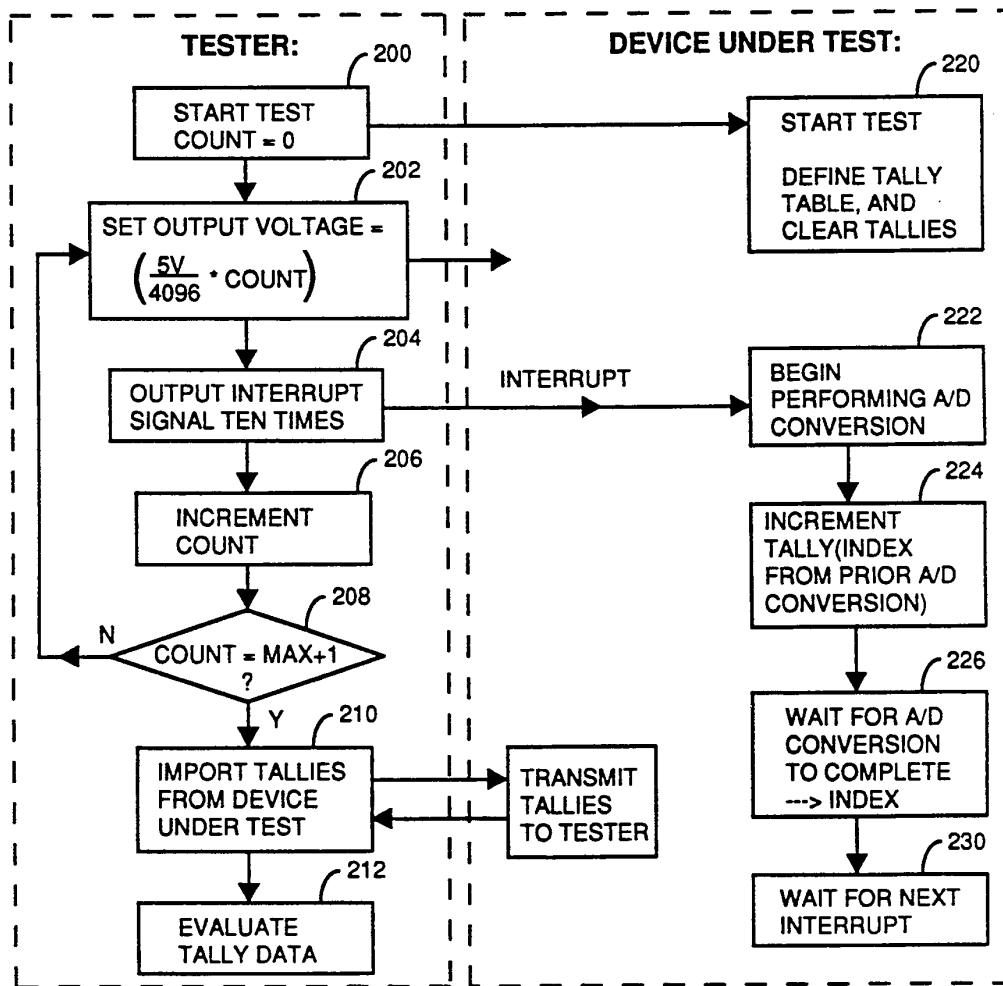

FIGURE 5

SYSTEM AND METHOD FOR TESTING ANALOG TO DIGITAL CONVERTER EMBEDDED IN MICROCONTROLLER

The present invention relates generally to testing complex semiconductor circuits, and particularly to methods and systems for testing the accuracy and linearity of an analog to digital converter which is embedded in a microcontroller or microprocessor.

BACKGROUND OF THE INVENTION

A number of microcontroller and microprocessor products now include an embedded analog to digital converter (ADC). This means that there is an ADC on the same semiconductor chip as the rest of the microcontroller's circuitry. For example, the COP888CF single chip CMOS controller made by National Semiconductor has an embedded ADC. In fact, that particular microcontroller has eight ADC channels (i.e., eight separate analog signal input connections). The development of such microcontrollers is a continuation of the trend toward putting all the circuitry needed for a programmable controller onto a single chip.

While complex semiconductor circuits with embedded circuits are convenient when building a product that needs a simple controller, such as a microwave oven controller, the presence of such embedded circuits makes it difficult to fully test the operation of the circuit.

Previous methods of testing embedded ADCs on digital VLSI test systems perform one conversion at a time. In other words, one analog signal is sent to the device under test, and the converted digital value is then read by the tester. The device under test is programmed to perform a conversion and then send the results of the conversion to the tester. Testing each possible output code of the ADC typically requires dozens of conversion and read sequences. Since the number of conversions typically used to test an eight bit ADC is in the range of 20,000 to 200,000, this testing method is very slow.

Another major disadvantage of the prior art methods of testing embedded ADCs is that the testing conditions do not match normal operating conditions. More specifically, when an embedded ADC is used in an actual application, the microcontroller will be performing many other operations, including computations, reading and writing data to and from registers and memory, and so on, all of which generate electromagnetic noise in the microcontroller. Standard prior art testing methods do not create the electromagnetic noise which is encountered during normal microcontroller operation.

SUMMARY OF THE INVENTION

In summary, the present invention is a tester system and method for testing the transfer characteristics and operability of an analog to digital converter (ADC) embedded in a microprocessor. The tester generates a sequence of analog signal test values, and prompts the microprocessor to read and convert each test value. The microprocessor sets up a table in its internal memory, the table having one tally value for every possible code output by the embedded ADC. After the embedded ADC converts each test value, the microprocessor reads the digital value output by the embedded ADC and increments a corresponding tally value in its internally stored table. When the sequence of tests is com-

pleted, the microprocessor transmits the entire table of tally values to the tester. The tester then performs a set of calculations on the tally data to determine the transfer characteristics and operability of the embedded ADC.

By performing all tally operations in the microprocessor under test, the test sequence can be performed much more quickly than if each converted value were separately transmitted by the microprocessor to the tester. In addition, the tallying operation of the microprocessor simulates normal operation of the microprocessor while performing analog to digital conversions, and thus the embedded ADC is subjected to electromagnetic noise characteristic of the microprocessor under normal operation.

Another important advantage of the present invention is that it enables an embedded ADC to be tested using a relatively inexpensive tester. In particular, the test equipment of the present invention does not need to perform measurements "on the fly"—all it needs is an accurate digital to analog converter for generating test voltages, plus a CPU with a few standard interface circuits for sending digital messages to and from the device under test.

BRIEF DESCRIPTION OF THE DRAWINGS

Additional objects and features of the invention will be more readily apparent from the following detailed description and appended claims when taken in conjunction with the drawings, in which:

FIG. 1 is a block diagram of a test apparatus for testing an analog to digital converter embedded in a microprocessor.

FIG. 2 is a block diagram of the circuits in a typical microcontroller having an embedded ADC.

FIG. 3 depicts a sequence of analog test signals used in a preferred embodiment.

FIG. 4 is a block diagram of a table of tally values stored in the random access memory of a microcontroller being tested.

FIG. 5 is a flow chart of a testing method in accordance with the present invention.

DESCRIPTION OF THE PREFERRED EMBODIMENT

The terms "microcontroller" and "microprocessor" are used interchangeably herein, both terms being used to refer to single chip data processing circuits. A microcontroller or microprocessor which has an "embedded ADC" is one with an analog to digital converter circuit on the same chip as the microcontroller or microprocessor's other circuitry.

Each digital value output by an analog to digital converter (ADC) is herein called a "code" or "output code". An eight bit ADC can output 256 distinct output codes, while a ten bit ADC can output 1024 distinct output codes.

Referring to FIGS. 1 and 2, the test apparatus 100 in the preferred embodiment includes a data processing unit 102, including test control software 104, a digital to analog converter (DAC) 106 with sixteen bit resolution, and a buffer 108 for transmitting data values received by the test apparatus to the data processing unit 102.

The device under test is a microprocessor 110 having an embedded analog to digital converter (ADC) 120, herein called the embedded ADC. The embedded ADC 120 typically has a resolution of eight or ten bits (i.e., 256 distinct output values or 1024 distinct output val-

ues). For the purposes of the explaining the invention, it is assumed that the embedded ADC 120 has a resolution of eight bits.

Most microcontrollers have the ability to execute instructions stored externally to the microcontroller 110, in addition to software stored in an internal ROM 122. The test system in the preferred embodiment includes a memory 130 external to the microcontroller which includes software 132-136 which is used while testing the embedded ADC 120. In particular, externally stored software 132 is used to initialize the microcontroller's internal random access memory (RAM) 140 by defining a table of values that will be described in more detail below with reference to FIGS. 4 and 5. Software 134 accumulates and stores data in the RAM 140 while the embedded ADC 120 is tested with a sequence of test values. Software 136 transmits the resulting table of values to the tester's data processing unit 102 at the conclusion of the test sequence.

The internal circuits of the microcontroller 110 generate noise which may or may not affect the operation of the ADC 120. FIG. 2 shows some of the common circuits found in most such microcontrollers, including an internal random access memory 140, arithmetic logic unit (ALU) 142, interrupt processing circuit 144, instruction decoder 146, timers 148, input/output port circuits 150, a watchdog circuit 152, register logic 154, program counter and address register circuits 156, and other miscellaneous circuitry 158. The present invention exercises at least some of these internal circuits while testing the operation of the ADC 120, thereby subjecting the ADC 120 to electromagnetic noise characteristic of the microcontroller 110 under normal operation.

In the preferred embodiment, the tester's DAC 106 has a resolution of sixteen bits while the embedded ADC 120 being tested has a resolution of only eight bits. Referring to FIG. 3, this enables the tester 100 to generate test voltages which take the form of a staircase of increasing voltage values within the nominal voltage range corresponding to each output code of the embedded ADC 120. For example, if the voltage range for a particular output code (e.g., output code 1) is 19.53 millivolts to 39.06 millivolts, the tester 100 will generate a staircase of N distinct test voltages within that range while testing the embedded ADC 120, where N is a positive integer such as eight or sixteen.

In the preferred embodiment, the tester 100 outputs sixteen voltage steps within the range assigned to each distinct output code of the embedded ADC 120. For an eight bit ADC 120 operating in a circuit with a maximum voltage swing of five volts, each distinct output code corresponds to a voltage range of about 19.53 millivolts (i.e., 5 volts divided by 256). To provide a staircase of test voltages with sixteen steps per output code, the tester generates test voltages which increase by about 1.22 millivolts per step, as shown in FIG. 3.

Referring to FIG. 4, a table 170 of "tally values" is stored in a table inside the microcontroller's RAM 120. Tallying works as follows. For an eight bit ADC there are 256 distinct output codes. Therefore, for this ADC 120 the test software will define a tally table 170 having 256 entries 172 for storing tally values, with values of zero initially stored in every entry. Then, every time the ADC 120 performs a conversion, an entry corresponding to the output code generated by the ADC is incremented. In other words, if the output code from the

ADC is equal to thirty-one (i.e., 1F hex), then entry thirty-one in the table 170 is incremented.

To generate a meaningful set of tally values, the tester 100 prompts the embedded ADC 120 to perform a large number of conversions while the input test voltage is within the voltage range corresponding to each distinct output code. For instance, in the preferred embodiment, the tester software 104 is set up to initiate 160 ADC conversions for each ADC output code. Thus, at the end of the test all the entries in the tally table 170 (except for possibly the first and last entries) for a perfect ADC 120 would be equal to 160.

FIG. 5 is a flow chart of the test software 104 in the tester 100 and the microcontroller's software 132-136 which is used while testing the embedded ADC 120. The tester initiates the beginning of the test by sending a first signal to the microcontroller and setting an internal counter (COUNT) to zero (step 200). The microcontroller 110 responds by defining and clearing a tally table 170 in its internal RAM 120 a tally table 170 (step 220).

Next (step 202), the tester sets the output voltage to be generated in accordance with the following formula:

$$\text{TEST VOLTAGE} = \left(\frac{5 \text{ Volts}}{4096} \cdot \text{COUNT} \right)$$

where 5 volts is the fully voltage range in which the ADC 120 is being tested, 4096 is the number of voltage steps being used, COUNT denotes the current voltage step being generated.

Once the test voltage has been set up, ten interrupt signals are sent to the microcontroller 110 (step 204) so as to prompt the embedded ADC 120 to convert the test voltage ten times. The microcontroller and its embedded ADC 120 respond to each interrupt signal by performing an ADC conversion, thereby generating an output code, which serves as an index into the tally table 170. The indexed entry in the table (i.e., the tally for the output code generated by the embedded ADC 120) is then incremented.

More specifically, in response to each interrupt signal, the embedded ADC 120 begins to perform an analog to digital conversion of the test voltage. However, it takes about a dozen of the microcontroller's CPU cycles for the conversion to be completed. During this time, the output code from the previous analog to digital conversion is used as an index into the tally table 170, and this indexed entry in the table is then incremented (step 224). Then the microcontroller waits for the current analog to digital conversion to complete (step 226), thereby generating the output code (or index) to be used for tallying during the next test cycle. Finally, the microcontroller waits for the next interrupt signal from the tester (step 230). Thus the process of performing an analog to digital conversion using the embedded ADC is overlapped with the tallying operation using the results of the prior analog to digital conversion.

After the tester has output ten interrupt signals (box 204) for the current test voltage, it increments its internal counter COUNT (box 206) and tests to see if the counter is equal to a predefined maximum value which corresponds to the last test voltage (box 208), which in this example would be a value of 4096. If the value of

Explore Litigation Insights

Docket Alarm provides insights to develop a more informed litigation strategy and the peace of mind of knowing you're on top of things.

Real-Time Litigation Alerts



Keep your litigation team up-to-date with **real-time alerts** and advanced team management tools built for the enterprise, all while greatly reducing PACER spend.

Our comprehensive service means we can handle Federal, State, and Administrative courts across the country.

Advanced Docket Research



With over 230 million records, Docket Alarm's cloud-native docket research platform finds what other services can't. Coverage includes Federal, State, plus PTAB, TTAB, ITC and NLRB decisions, all in one place.

Identify arguments that have been successful in the past with full text, pinpoint searching. Link to case law cited within any court document via Fastcase.

Analytics At Your Fingertips



Learn what happened the last time a particular judge, opposing counsel or company faced cases similar to yours.

Advanced out-of-the-box PTAB and TTAB analytics are always at your fingertips.

API

Docket Alarm offers a powerful API (application programming interface) to developers that want to integrate case filings into their apps.

LAW FIRMS

Build custom dashboards for your attorneys and clients with live data direct from the court.

Automate many repetitive legal tasks like conflict checks, document management, and marketing.

FINANCIAL INSTITUTIONS

Litigation and bankruptcy checks for companies and debtors.

E-DISCOVERY AND LEGAL VENDORS

Sync your system to PACER to automate legal marketing.