



US005796183C1

(12) **EX PARTE REEXAMINATION CERTIFICATE** (9614th)
United States Patent
Hourmand et al.

(10) **Number:** **US 5,796,183 C1**
(45) **Certificate Issued:** **Apr. 29, 2013**

(54) **CAPACITIVE RESPONSIVE ELECTRONIC SWITCHING CIRCUIT**

(58) **Field of Classification Search**
None
See application file for complete search history.

(75) Inventors: **Byron Hourmand**, Hersey, MI (US);
John M. Washeleski, Cadillac, MI (US);
Stephen R. W. Cooper, Fowlerville, MI (US)

(56) **References Cited**

(73) Assignee: **Nartron Corporation**, Reed City, MI (US)

To view the complete listing of prior art documents cited during the proceeding for Reexamination Control Number 90/012,439, please refer to the USPTO's public Patent Application Information Retrieval (PAIR) system under the Display References tab.

Primary Examiner — Linh M. Nguyen

Reexamination Request:
No. 90/012,439, Aug. 17, 2012

(57) **ABSTRACT**

Reexamination Certificate for:
Patent No.: **5,796,183**
Issued: **Aug. 18, 1998**
Appl. No.: **08/601,268**
Filed: **Jan. 31, 1996**

A capacitive responsive electronic switching circuit comprises an oscillator providing a periodic output signal having a frequency of 50 kHz or greater, an input touch terminal defining an area for an operator provide an input by proximity and touch, and a detector circuit coupled to the oscillator for receiving the periodic output signal from the oscillator, and coupled to the input touch terminal. The detector circuit being responsive to signals from the oscillator and the presence of an operator's body capacitance to ground coupled to the touch terminal when in proximity or touched by an operator to provide a control output signal. Preferably, the oscillator provides a periodic output signal having a frequency of 800 kHz or greater. An array of touch terminals may be provided in close proximity due to the reduction in crosstalk that may result from contaminants by utilizing an oscillator outputting a signal having a frequency of 50 kHz or greater.

Certificate of Correction issued May 11, 1999

Certificate of Correction issued Oct. 11, 2011

(51) **Int. Cl.**
H03K 17/96 (2006.01)
H03K 17/94 (2006.01)

(52) **U.S. Cl.**
USPC **307/116; 307/125; 307/139; 361/181**

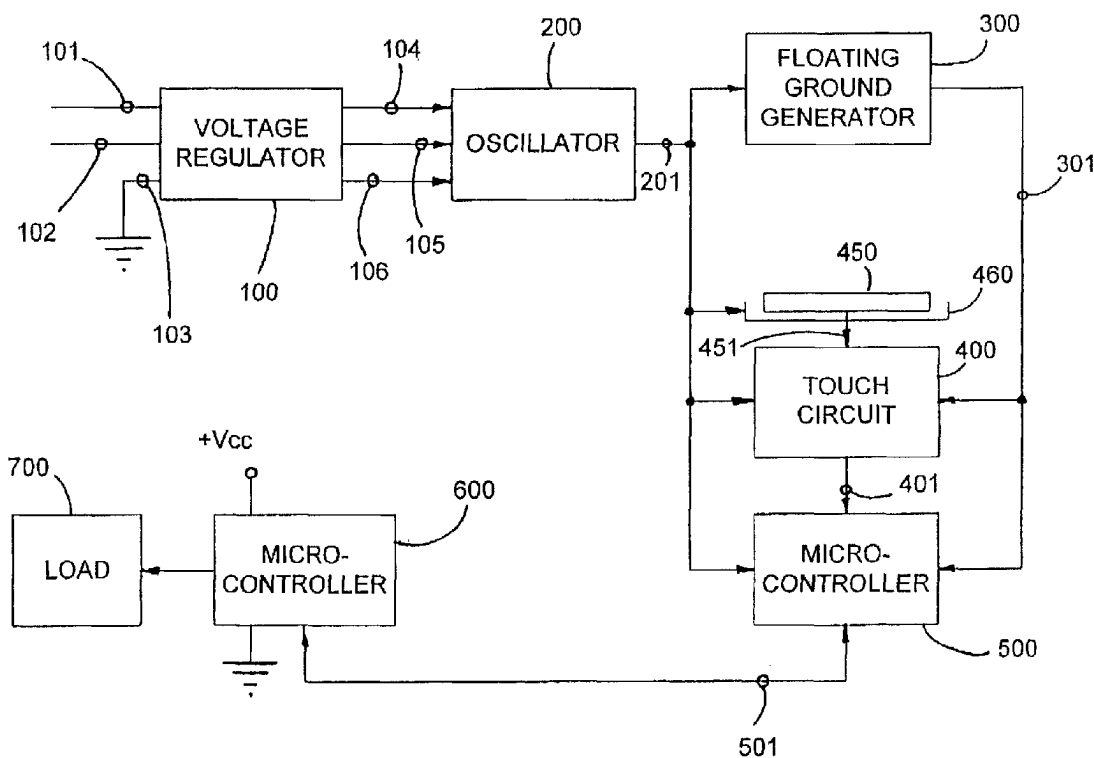

1
EX PARTE
REEXAMINATION CERTIFICATE
ISSUED UNDER 35 U.S.C. 307

THE PATENT IS HEREBY AMENDED AS
INDICATED BELOW.

Matter enclosed in heavy brackets [] appeared in the patent, but has been deleted and is no longer a part of the patent; matter printed in italics indicates additions made to the patent.

AS A RESULT OF REEXAMINATION, IT HAS BEEN DETERMINED THAT:

Claims 18, 27, 28 and 32 are determined to be patentable as amended.

New claims 33-39 are added and determined to be patentable.

Claims 1-17, 19-26 and 29-31 were not reexamined.

18. A capacitive responsive electronic switching circuit comprising:

an oscillator providing a periodic output signal having a predefined frequency;

a microcontroller using the periodic output signal from the oscillator, the microcontroller selectively providing signal output frequencies to a plurality of small sized input touch terminals of a keypad;

[a] *the plurality of small sized input touch terminals defining adjacent areas on a dielectric substrate for an operator to provide inputs by proximity and touch; and a detector circuit coupled to said oscillator for receiving said periodic output signal from said oscillator, and coupled to said input touch terminals, said detector circuit being responsive to signals from said oscillator via said microcontroller and [the] a presence of an operator's body capacitance to ground coupled to said touch terminals when proximal or touched by [an] the operator to provide a control output signal,*

wherein said predefined frequency of said oscillator [is] and said signal output frequencies are selected to decrease [the] a first impedance of said dielectric substrate relative to [the] a second impedance of any contaminate that may create an electrical path on said dielectric substrate between said adjacent areas defined by the plurality of small sized input touch terminals, and wherein said detector circuit compares [the] a sensed body capacitance change to ground proximate an input touch terminal to a threshold level to prevent inadvertent generation of the control output signal.

27. A capacitive responsive electronic switching circuit for a controlled keypad device comprising:

an oscillator providing a periodic output signal having a predefined frequency;

a microcontroller using the periodic output signal from the oscillator, the microcontroller selectively providing signal output frequencies to a closely spaced array of input touch terminals of a keypad, the input touch terminals comprising first and second input touch terminals;

the first and second input touch terminals defining areas for an operator to provide an input by proximity and touch; and

a detector circuit coupled to said oscillator for receiving said periodic output signal from said oscillator, and coupled to said first and second touch terminals, said

2

detector circuit being responsive to signals from said oscillator via said microcontroller and [the] a presence of an operator's body capacitance to ground coupled to said first and second touch terminals when proximal or touched by [an] the operator to provide a control output signal for actuation of the controlled keypad device, said detector circuit being configured to generate said control output signal when [an] the operator is proximal or touches said second touch terminal after the operator is proximal or touches said first touch terminal.

28. The capacitive responsive electronic switching circuit as defined in claim 27, wherein said detector circuit generates said control signal only when [an] the operator is proximal or touches said second touch terminal within a predetermined time period after the operator is proximal or touches said first touch terminal.

32. The capacitive responsive electronic switching circuit as defined in claim 27 and further including an indicator for indicating when said detector circuit determines that [an] the operator is proximal or touches said first touch terminal.

33. *The capacitive responsive electronic switching circuit as defined in claim 18, further comprising wherein said detector circuit compares the sensed body capacitance change caused by the body capacitance decreasing an input touch terminal signal on the detector to ground when proximate to the input touch terminal to a second threshold level to generate the control output signal.*

34. *The capacitive responsive electronic switching circuit as defined in claim 18, further comprising wherein said detector circuit compares the sensed body capacitance change caused by the body capacitance decreasing an input touch terminal signal amplitude on the detector to ground when proximate to the input touch terminal to a second threshold level to generate the control output signal.*

35. *The capacitive responsive electronic switching circuit as defined in claim 27, wherein when the second touch terminal is not touched on its defining area by the operator to provide input, the control output signal is prevented.*

36. *The capacitive responsive electronic switching circuit as defined in claim 27 and further including an indicator for indicating when said detector circuit determines that the operator is proximal or touches said second touch terminal.*

37. *A capacitive responsive electronic switching circuit for a controlled device comprising:*

an oscillator providing a periodic output signal having a predefined frequency, wherein an oscillator voltage is greater than a supply voltage;

a microcontroller using the periodic output signal from the oscillator, the microcontroller selectively providing signal output frequencies to a closely spaced array of input touch terminals of a keypad, the input touch terminals comprising first and second input touch terminals;

the first and second touch terminals defining areas for an operator to provide an input by proximity and touch; and

a detector circuit coupled to said oscillator for receiving said periodic output signal from said oscillator, and coupled to said first and second touch terminals, said detector circuit being responsive to signals from said oscillator via said microcontroller and a presence of an operator's body capacitance to ground coupled to said first and second touch terminals when proximal or touched by the operator to provide a control output signal for actuation of the controlled device, said detector circuit being configured to generate said control output signal when the operator is proximal or touches said second touch terminal after the operator is proximal or touches said first touch terminal.

3

4

38. The capacitive responsive electronic switching circuit as defined in claim 37, wherein feedback to the operator is provided by an indicator activated by the microcontroller after the operator touches the second touch terminal.

39. The capacitive responsive electronic switching circuit 5 as defined in claim 37,

wherein said detector circuit compares a sensed body capacitance change caused by the body capacitance decreasing a second touch terminal signal on the detector to ground when proximate to the second touch terminal to a threshold level to generate the control output signal, and

wherein feedback to the operator is provided by an indicator activated by the microcontroller after the operator touches the second touch terminal. 15

* * * * *



UNITED STATES PATENT AND TRADEMARK OFFICE

UNITED STATES DEPARTMENT OF COMMERCE
United States Patent and Trademark Office
Address: COMMISSIONER FOR PATENTS
P.O. Box 1450
Alexandria, Virginia 22313-1450
www.uspto.gov

APPLICATION NO.	FILING DATE	FIRST NAMED INVENTOR	ATTORNEY DOCKET NO.	CONFIRMATION NO.
-----------------	-------------	----------------------	---------------------	------------------

90/012,439	08/17/2012	5796183	NAR-5796183RX	4155
------------	------------	---------	---------------	------

25962 7590 04/10/2013
 SLATER & MATSIL, L.L.P.
 17950 PRESTON RD, SUITE 1000
 DALLAS, TX 75252-5793

EXAMINER

NGUYEN, LINH M

ART UNIT	PAPER NUMBER
----------	--------------

3992

MAIL DATE	DELIVERY MODE
-----------	---------------

04/10/2013

PAPER

Please find below and/or attached an Office communication concerning this application or proceeding.

The time period for reply, if any, is set in the attached communication.

Notice of Intent to Issue Ex Parte Reexamination Certificate	Control No.	Patent Under Reexamination
	90/012,439	5796183
	Examiner	Art Unit
	LINH M. NGUYEN	3992

-- The MAILING DATE of this communication appears on the cover sheet with the correspondence address --

1. Prosecution on the merits is (or remains) closed in this *ex parte* reexamination proceeding. This proceeding is subject to reopening at the initiative of the Office or upon petition. *Cf.* 37 CFR 1.313(a). A Certificate will be issued in view of
 - (a) Patent owner's communication(s) filed: 19 November 2012.
 - (b) Patent owner's failure to file an appropriate timely response to the Office action mailed: _____.
 - (c) Patent owner's failure to timely file an Appeal Brief (37 CFR 41.31).
 - (d) The decision on appeal by the Board of Patent Appeals and Interferences Court dated _____
 - (e) Other: _____.
2. The Reexamination Certificate will indicate the following:
 - (a) Change in the Specification: Yes No
 - (b) Change in the Drawing(s): Yes No
 - (c) Status of the Claim(s):
 - (1) Patent claim(s) confirmed: _____.
 - (2) Patent claim(s) amended (including dependent on amended claim(s)): 18,27,28 and 32
 - (3) Patent claim(s) canceled: _____.
 - (4) Newly presented claim(s) patentable: 33-39.
 - (5) Newly presented canceled claims: _____.
 - (6) Patent claim(s) previously currently disclaimed: _____
 - (7) Patent claim(s) not subject to reexamination: 1-17, 19-26 and 29-31.
3. Note the attached statement of reasons for patentability and/or confirmation. Any comments considered necessary by patent owner regarding reasons for patentability and/or confirmation must be submitted promptly to avoid processing delays. Such submission(s) should be labeled: "Comments On Statement of Reasons for Patentability and/or Confirmation."
4. Note attached NOTICE OF REFERENCES CITED (PTO-892).
5. Note attached LIST OF REFERENCES CITED (PTO/SB/08 or PTO/SB/08 substitute).
6. The drawing correction request filed on _____ is: approved disapproved.
7. Acknowledgment is made of the priority claim under 35 U.S.C. § 119(a)-(d) or (f).
 - a) All b) Some* c) None of the certified copies have
 - been received.
 - not been received.
 - been filed in Application No. _____.
 - been filed in reexamination Control No. _____.
 - been received by the International Bureau in PCT Application No. _____.

* Certified copies not received: _____.
8. Note attached Examiner's Amendment.
9. Note attached Interview Summary (PTO-474).
10. Other: _____.

All correspondence relating to this reexamination proceeding should be directed to the **Central Reexamination Unit** at the mail, FAX, or hand-carry addresses given at the end of this Office action.

cc: Requester (if third party requester)

Notice of Intent to Issue Reexamination Certificate

This is a reexamination of United States Patent Number 5,796,183 ("the 183' patent"). In the reexamination request filed 08/17/2012 ("Request"), by Patent Owner, a substantial new question (SNQ) of patentability was raised as to claims 18 and 27. Those claims are thus reexamined herein. Reexamination was not requested of claims 1-17, 19-26 and 28-32. Therefore, claims 1-17, 19-26, and 27-31 will not be reexamined. See MPEP 2243. However, claims 28 and 32 will be reexamined, as further explained below.

A Patent Owner Statement was filed 11/19/2012, in which claims 18 and 27 were amended, as well as claims 28 and 32 due to their dependencies from claim 27. Furthermore, new claims 33-39 were added.

Within the examiner's discretion, the newly added claims 33-39 and the non-requested amended claims 28 and 32 are now subject to reexamination.

References

Boie et al., U.S. Patent No. 5,463,388, filed on January 29, 1993 and issued on October 31, 1996 ("Boie '388").

Statement of Reasons for Patentability and/or Confirmation

Claims 18, 27, amended non-requested claims 28, 32 and newly added claims 33-39 are patentable.

The examiner has no opinion as to the claims that were not reexamined. The following is an examiner's statement of reasons for patentability of the claims found patentable in this reexamination proceeding:

There is not taught or disclosed in the prior art *a capacitive responsive electronic switching circuit having a microcontroller using the periodic output signal from the oscillator, the microcontroller selectively providing signal output frequencies to a plurality of small sized input touch terminals of a keypad*, as called for in independent claim 18; nor *a capacitive responsive electronic switching circuit having a microcontroller using the periodic output signal from the oscillator, the microcontroller selectively providing signal output frequencies to a closely spaced array of input touch terminals of a keypad, the input touch terminals comprising first and second input touch terminals*, as called for in independent claims 27 and 37. The examiner agrees with the discussion articulated by Patent Owner in the Statement that Boie does not teach or suggest these claim elements. Rather, Boie discloses that "RF oscillator 408 provides an RF signal, for example, 100 kilohertz, to circuits 401, synchronous detector and filter 404 via inverter 410, and guard plane 411." Boie, col. 3:67-col. 4:2. Boie further discloses that "[t]he effects of electrode-to-electrode capacitances, wiring capacitances and other extraneous

Art Unit: 3992

capacitances are minimized by driving all electrodes and guard plane 411 in unison with the same RF signal from RF oscillator 408." *Id.* at col. 4:58-60 (emphasis added); *see id.* at Fig. 4. Thus Boie discloses driving the electrodes of electrode array 100 and guard plane 411 with a single RF signal. Boie does not teach or suggest providing signal output frequencies to these components. Accordingly, claims 18, 27, amended non-requested claims 28, 32, and newly added claims 33-39 are patentable.

Any comments considered necessary by PATENT OWNER regarding the above statement must be submitted promptly to avoid processing delays. Such submission by the patent owner should be labeled: "Comments on Statement of Reasons for Patentability and/or Confirmation" and will be placed in the reexamination file.

Correspondence

All correspondence relating to this *inter partes* reexamination proceeding should be directed:

By Mail to: Mail Stop *Inter Partes* Reexam
Attn: Central Reexamination Unit
Commissioner for Patents
United States Patent & Trademark Office
P.O. Box 1450
Alexandria, VA 22313-1450

By FAX to: (571) 273-9900
Central Reexamination Unit

By hand: Customer Service Window
Randolph Building
401 Dulany Street
Alexandria, VA 22314

Registered users of EFS-Web may alternatively submit such correspondence via the electronic filing system EFS-Web, at <https://efs.uspto.gov/efile/myportal/efs-registered> EFS-Web offers the benefit of quick submission to the particular area of the Office that needs to act on the correspondence. Also, EFS-Web submissions are “soft scanned” (i.e., electronically uploaded) directly into the official file for the reexamination proceeding, which offers parties the opportunity to review the content of their submissions after the “soft scanning” process is complete.

Any inquiry concerning this communication or earlier communications from the examiner, or as to the status of this proceeding, should be directed to the Central Reexamination Unit at telephone number (571) 272-7705.

/Linh M. Nguyen/
Primary Examiner, Art Unit 3992

Conferees:

/James Menefee/
Primary Examiner, Art Unit 3992

/Daniel Ryman/
Supervisory Patent Examiner, Art Unit 3992

Issue Classification 	Application/Control No.		Applicant(s)/Patent under Reexamination	
	90/012,439		5796183	
	Examiner		Art Unit	
LINH M. NGUYEN		3992		

ISSUE CLASSIFICATION											
ORIGINAL					CROSS REFERENCE(S)						
CLASS		SUBCLASS			CLASS	SUBCLASS (ONE SUBCLASS PER BLOCK)					
307		116			307	125	139				
INTERNATIONAL CLASSIFICATION					361	181					
H	0	3	K	17/96							
H	0	3	K	17/94							
				/							
				/							
				/							
N/A (Assistant Examiner) (Date)					/Linh M. Nguyen/ 3/27/2013 (Primary Examiner) (Date)					Total Claims Allowed: 11	
/A. Kelley-Collier/ (Legal Instruments Examiner) (Date)										O.G. Print Claim(s) 18	

<input checked="" type="checkbox"/> Claims renumbered in the same order as presented by applicant										<input type="checkbox"/> CPA		<input type="checkbox"/> T.D.		<input type="checkbox"/> R.1.47	
Final	Original	Final	Original	Final	Original	Final	Original	Final	Original	Final	Original	Final	Original	Final	Original
	1		31		61		91		121		151		181		
	2		32		62		92		122		152		182		
	3		33		63		93		123		153		183		
	4		34		64		94		124		154		184		
	5		35		65		95		125		155		185		
	6		36		66		96		126		156		186		
	7		37		67		97		127		157		187		
	8		38		68		98		128		158		188		
	9		39		69		99		129		159		189		
	10		40		70		100		130		160		190		
	11		41		71		101		131		161		191		
	12		42		72		102		132		162		192		
	13		43		73		103		133		163		193		
	14		44		74		104		134		164		194		
	15		45		75		105		135		165		195		
	16		46		76		106		136		166		196		
	17		47		77		107		137		167		197		
	18		48		78		108		138		168		198		
	19		49		79		109		139		169		199		
	20		50		80		110		140		170		200		
	21		51		81		111		141		171		201		
	22		52		82		112		142		172		202		
	23		53		83		113		143		173		203		
	24		54		84		114		144		174		204		
	25		55		85		115		145		175		205		
	26		56		86		116		146		176		206		
	27		57		87		117		147		177		207		
	28		58		88		118		148		178		208		
	29		59		89		119		149		179		209		
	30		60		90		120		150		180		210		



UNITED STATES PATENT AND TRADEMARK OFFICE

UNITED STATES DEPARTMENT OF COMMERCE
 United States Patent and Trademark Office
 Address: COMMISSIONER FOR PATENTS
 P.O. Box 1450
 Alexandria, Virginia 22313-1450
 www.uspto.gov

BIB DATA SHEET

CONFIRMATION NO. 4155

SERIAL NUMBER 90/012,439	FILING or 371(c) DATE 08/17/2012 RULE	CLASS 307	GROUP ART UNIT 3992	ATTORNEY DOCKET NO. NAR-5796183RX		
APPLICANTS 5796183, Residence Not Provided; OWNER, REED CITY, MI; PATENT OWNER, REED CITY, MI; ** CONTINUING DATA ***** This application is a REX of 08/601,268 01/31/1996 PAT 5796183 ** FOREIGN APPLICATIONS ***** ** IF REQUIRED, FOREIGN FILING LICENSE GRANTED **						
Foreign Priority claimed <input type="checkbox"/> Yes <input checked="" type="checkbox"/> No 35 USC 119(a-d) conditions met <input type="checkbox"/> Yes <input checked="" type="checkbox"/> No Verified and /LINH M NGUYEN/ Acknowledged Examiner's Signature		<input type="checkbox"/> Met after Allowance Initials	STATE OR COUNTRY	SHEETS DRAWINGS	TOTAL CLAIMS 32	INDEPENDENT CLAIMS 8
ADDRESS SLATER & MATSIL, L.L.P. 17950 PRESTON RD, SUITE 1000 DALLAS, TX 75252-5793 UNITED STATES						
TITLE Capacitive Responsive Electronic Switching Circuit						
FILING FEE RECEIVED 2520	FEES: Authority has been given in Paper No. _____ to charge/credit DEPOSIT ACCOUNT No. _____ for following:		<input type="checkbox"/> All Fees <input type="checkbox"/> 1.16 Fees (Filing) <input type="checkbox"/> 1.17 Fees (Processing Ext. of time) <input type="checkbox"/> 1.18 Fees (Issue) <input type="checkbox"/> Other _____ <input type="checkbox"/> Credit			

90/012, 439

IN THE UNITED STATES PATENT AND TRADEMARK OFFICE

U.S. Patent No.:	5,796,183 B1	§	Docket No.:	NAR-5796183RX
Issued:	August 18, 1998	§	Inventors:	Hourmand et al.
Filed:	January 31, 1996	§	Patent Owner:	UUSI, LLC
Control No.	TBD	§	Examiner:	Nguyen, Linh M.

For: Capacitive Responsive Electronic Switching Circuit

Mail Stop *Ex Parte* Reexam
Attn: Central Reexamination Unit
Commissioner for Patents
P.O. Box 1450
Alexandria, VA 22313-1450

PATENT OWNER STATEMENT

Dear Sir:

Patent Owner respectfully submits this Patent Owner Statement in response to the September 20, 2012 Order Granting Request for *Ex Parte* Reexamination of U.S. Patent Number 5,796,183 B1 (the "183 Patent"). Patent Owner respectfully requests that the following amendments and remarks be entered, and respectfully requests consideration of amended claims 18, 27, 28 and 32, and newly-added claims 33-39.

Please enter Amendment
Thanks,
LMN 3/27/2013

Reexamination 	Application/Control No. 90/012,439	Applicant(s)/Patent Under Reexamination 5796183
	Certificate Date	Certificate Number C1

Requester Correspondence Address: <input checked="" type="checkbox"/> Patent Owner <input type="checkbox"/> Third Party
SLATER & MATSIL, L.L.P. 17950 PRESTON RD, SUITE 1000 DALLAS, TX 75252-5793

LITIGATION REVIEW <input checked="" type="checkbox"/>	LMN <small>(examiner initials)</small>	3/27/2013 <small>(date)</small>
Case Name	Director Initials	
U.S. District - Michigan Western (Grand Rapids) 1:10cv691 (CLOSED) Nartron Corporation et al v. Hourmand		
US District Court Civil Docket U.S. District- Pennsylvania Middle (Harrisburg) 1:06cv1777 Orq, Ltd, A/K/A Quantum Research Group, Ltd v. Nartron Corporatio (CLOSED)		
U.S. District - Pennsylvania Western (Pittsburgh) 2:06cv500 Qrg, Ltd v. Nartron Corporation (CLOSED)		

TYPE OF PROCEEDING	NUMBER
1. N/A	

2.	
3.	
4.	

IN THE UNITED STATES PATENT AND TRADEMARK OFFICE

U.S. Patent No.:	5,796,183 B1	§	Docket No.:	NAR-5796183RX
Issued:	August 18, 1998	§	Inventors:	Hourmand et al.
Filed:	January 31, 1996	§	Patent Owner:	UUSI, LLC
Control No.	TBD	§	Examiner:	Nguyen, Linh M.

For: Capacitive Responsive Electronic Switching Circuit

Mail Stop *Ex Parte* Reexam
Attn: Central Reexamination Unit
Commissioner for Patents
P.O. Box 1450
Alexandria, VA 22313-1450

PATENT OWNER STATEMENT

Dear Sir:

Patent Owner respectfully submits this Patent Owner Statement in response to the September 20, 2012 Order Granting Request for *Ex Parte* Reexamination of U.S. Patent Number 5,796,183 B1 (the “183 Patent”). Patent Owner respectfully requests that the following amendments and remarks be entered, and respectfully requests consideration of amended claims 18, 27, 28 and 32, and newly-added claims 33-39.

1. Listing Of The `183 Patent Claims Under Reexamination

A listing of each claim under reexamination is provided below. Reexamination of claims 18 and 27 was granted in the Order dated September 20, 2012. Accordingly, please amend claims 18 and 27, as well claims 28 and 32, which depend from claim 27, as provided below. In addition, please add new claims 33-39 as follows.

18. (Amended) A capacitive responsive electronic switching circuit comprising:
an oscillator providing a periodic output signal having a predefined frequency;
a microcontroller using the periodic output signal from the oscillator, the microcontroller selectively providing signal output frequencies to a plurality of small sized input touch terminals of a keypad;

[a] the plurality of small sized input touch terminals defining adjacent areas on a dielectric substrate for an operator to provide inputs by proximity and touch; and

a detector circuit coupled to said oscillator for receiving said periodic output signal from said oscillator, and coupled to said input touch terminals, said detector circuit being responsive to signals from said oscillator via said microcontroller and [the] a presence of an operator's body capacitance to ground coupled to said touch terminals when proximal or touched by [an] the operator to provide a control output signal,

wherein said predefined frequency of said oscillator [is] and said signal output frequencies are selected to decrease [the] a first impedance of said dielectric substrate relative to [the] a second impedance of any contaminate that may create an electrical path on said dielectric substrate between said adjacent areas defined by the plurality of small sized input touch terminals, and wherein said detector circuit compares [the] a sensed body capacitance change to

ground proximate an input touch terminal to a threshold level to prevent inadvertent generation of the control output signal.

27. (Amended) A capacitive responsive electronic switching circuit for a controlled keypad device comprising:

an oscillator providing a periodic output signal having a predefined frequency;

a microcontroller using the periodic output signal from the oscillator, the microcontroller selectively providing signal output frequencies to a closely spaced array of input touch terminals of a keypad, the input touch terminals comprising first and second input touch terminals;

the first and second input touch terminals defining areas for an operator to provide an input by proximity and touch; and

a detector circuit coupled to said oscillator for receiving said periodic output signal from said oscillator, and coupled to said first and second touch terminals, said detector circuit being responsive to signals from said oscillator via said microcontroller and [the] a presence of an operator's body capacitance to ground coupled to said first and second touch terminals when proximal or touched by [an] the operator to provide a control output signal for actuation of the controlled keypad device, said detector circuit being configured to generate said control output signal when [an] the operator is proximal or touches said second touch terminal after the operator is proximal or touches said first touch terminal.

28. (Amended) The capacitive responsive electronic switching circuit as defined in claim 27, wherein said detector circuit generates said control signal only when [an] the operator is proximal or touches said second touch terminal within a predetermined time period after the operator is proximal or touches said first touch terminal.

32. (Amended) The capacitive responsive electronic switching circuit as defined in claim 27 and further including an indicator for indicating when said detector circuit determines that [an] the operator is proximal or touches said first touch terminal.

33. (New) The capacitive responsive electronic switching circuit as defined in claim 18, further comprising wherein said detector circuit compares the sensed body capacitance change caused by the body capacitance decreasing an input touch terminal signal on the detector to ground when proximate to the input touch terminal to a second threshold level to generate the control output signal.

34. (New) The capacitive responsive electronic switching circuit as defined in claim 18, further comprising wherein said detector circuit compares the sensed body capacitance change caused by the body capacitance decreasing an input touch terminal signal amplitude on the detector to ground when proximate to the input touch terminal to a second threshold level to generate the control output signal.

35. (New) The capacitive responsive electronic switching circuit as defined in claim 27, wherein when the second touch terminal is not touched on its defining area by the operator to provide input, the control output signal is prevented.

36. (New) The capacitive responsive electronic switching circuit as defined in claim 27 and further including an indicator for indicating when said detector circuit determines that the operator is proximal or touches said second touch terminal.

37. (New) A capacitive responsive electronic switching circuit for a controlled device

comprising:

an oscillator providing a periodic output signal having a predefined frequency, wherein an oscillator voltage is greater than a supply voltage;

a microcontroller using the periodic output signal from the oscillator, the microcontroller selectively providing signal output frequencies to a closely spaced array of input touch terminals of a keypad, the input touch terminals comprising first and second input touch terminals;

the first and second touch terminals defining areas for an operator to provide an input by proximity and touch; and

a detector circuit coupled to said oscillator for receiving said periodic output signal from said oscillator, and coupled to said first and second touch terminals, said detector circuit being responsive to signals from said oscillator via said microcontroller and a presence of an operator's body capacitance to ground coupled to said first and second touch terminals when proximal or touched by the operator to provide a control output signal for actuation of the controlled device, said detector circuit being configured to generate said control output signal when the operator is proximal or touches said second touch terminal after the operator is proximal or touches said first touch terminal.

38. (New) The capacitive responsive electronic switching circuit as defined in claim 37, wherein feedback to the operator is provided by an indicator activated by the microcontroller after the operator touches the second touch terminal.

39. (New) The capacitive responsive electronic switching circuit as defined in claim 37,

wherein said detector circuit compares a sensed body capacitance change caused by the

body capacitance decreasing a second touch terminal signal on the detector to ground when proximate to the second touch terminal to a threshold level to generate the control output signal, and

wherein feedback to the operator is provided by an indicator activated by the microcontroller after the operator touches the second touch terminal.

II. Status of the Claims

Claims 1-39 are pending in the present reexamination proceeding, of which claims 18, 27, 28 and 32 are amended herein and 33-39 are added herein.

III. Discussion of Claims and Prior Art Reference

Patent Owner filed a Request for *Ex Parte* Reexamination on August 17, 2012, submitting that a substantial new question of patentability of claims 18 and 27 is raised by Boie et al., U.S. Patent No. 5,463,388 (“Boie”). Reexamination of these claims was granted in the Order dated September 20, 2012.

Patent Owner is amending claims 18 and 27 in this Patent Owner Statement. Because some of these amendments were made to provide better antecedent basis for some claim terms, Patent Owner is amending dependent claims 28 and 32 for the same reason. Patent Owner also is adding new claims 33-39. Accordingly, Patent Owner respectfully requests consideration of amended claims 18, 27, 28 and 32, and new claims 33-39. No new matter has been added.

A. Independent Claim 18

Independent claim 18 recites “a microcontroller using the periodic output signal from the oscillator, the microcontroller selectively providing signal output frequencies to a plurality of small sized input touch terminals of a keypad.” Boie does not teach or suggest these claim elements.

Rather, Boie discloses that “RF oscillator 408 provides an RF signal, for example, 100 kilohertz, to circuits 401, synchronous detector and filter 404 via inverter 410, and guard plane 411.” Boie, col. 3:67-col. 4:2. Boie further discloses that “[t]he effects of electrode-to-electrode

capacitances, wiring capacitances and other extraneous capacitances are minimized by driving all electrodes and guard plane 411 in unison with the same RF signal from RF oscillator 408.” *Id.* at col. 4:58-60 (emphasis added); *see id.* at Fig. 4. Thus Boie discloses driving the electrodes of electrode array 100 and guard plane 411 with a single RF signal. Boie does not teach or suggest providing signal output frequencies to these components. Accordingly, Boie does not disclose all of the elements of claim 18, and therefore claim 18 is patentable over Boie.

New claims 33 and 34 depend from claim 18 and add further limitations. Patent Owner respectfully submits that these dependent claims are allowable by reason of depending from an allowable claim as well as for adding new limitations.

B. Independent Claim 27

Independent claim 27 recites “a microcontroller using the periodic output signal from the oscillator, the microcontroller selectively providing signal output frequencies to a closely spaced array of input touch terminals of a keypad, the input touch terminals comprising first and second input touch terminals.” Boie does not teach or suggest these claim elements.

Rather, Boie discloses that “RF oscillator 408 provides an RF signal, for example, 100 kilohertz, to circuits 401, synchronous detector and filter 404 via inverter 410, and guard plane 411.” Boie, col. 3:67-col. 4:2. Boie further discloses that “[t]he effects of electrode-to-electrode capacitances, wiring capacitances and other extraneous capacitances are minimized by driving all electrodes and guard plane 411 in unison with the same RF signal from RF oscillator 408.” *Id.* at col. 4:58-60 (emphasis added); *see id.* at Fig. 4. Thus Boie discloses driving the electrodes of electrode array 100 and guard plane 411 with a single RF signal. Boie does not teach or suggest

providing signal output frequencies to these components. Accordingly, Boie does not disclose all of the elements of claim 27, and therefore claim 27 is patentable over Boie.

Amended claims 28 and 32, and new claims 35-36, depend from claim 27 and add further limitations. Patent Owner respectfully submits that these dependent claims are allowable by reason of depending from an allowable claim as well as for adding new limitations.

C. Independent Claim 37

Independent claim 37 recites “a microcontroller using the periodic output signal from the oscillator, the microcontroller selectively providing signal output frequencies to a closely spaced array of input touch terminals of a keypad, the input touch terminals comprising first and second input touch terminals.” Boie does not teach or suggest these claim elements.

Rather, Boie discloses that “RF oscillator 408 provides an RF signal, for example, 100 kilohertz, to circuits 401, synchronous detector and filter 404 via inverter 410, and guard plane 411.” Boie, col. 3:67-col. 4:2. Boie further discloses that “[t]he effects of electrode-to-electrode capacitances, wiring capacitances and other extraneous capacitances are minimized by driving all electrodes and guard plane 411 in unison with the same RF signal from RF oscillator 408.” *Id.* at col. 4:58-60 (emphasis added); *see id.* at Fig. 4. Thus Boie discloses driving the electrodes of electrode array 100 and guard plane 411 with a single RF signal. Boie does not teach or suggest providing signal output frequencies to these components.

Independent claim 37 further recites “an oscillator providing a periodic output signal having a predefined frequency, wherein an oscillator voltage is greater than a supply voltage.” Boie is silent regarding an oscillator voltage being greater than a supply voltage.

For at least the above reasons, Boie does not disclose all of the elements of claim 37, and therefore claim 37 is patentable over Boie.

New claims 38-39 depend from claim 37 and add further limitations. Patent Owner respectfully submits that these dependent claims are allowable by reason of depending from an allowable claim as well as for adding new limitations.

IV. Support for Claim Amendments and New Claims

Support for each of the amendments to claims 18, 27, 28 and 32, and for new claims 33-39, may be found throughout the `183 Patent, and particular support may be found, for example, as set forth in the charts below.

A. Amended Claim 18

`183 Patent Claim Language	`183 Patent Support
18. A capacitive responsive electronic switching circuit comprising:	--
an oscillator providing a periodic output signal having a predefined frequency;	--
<u>a microcontroller using the periodic output signal from the oscillator, the microcontroller selectively providing signal output frequencies to a plurality of small sized input touch terminals of a keypad;</u>	<p>See Figures 4, 11; and Claims 8, 12, 16.</p> <p>The `183 Patent discloses “The touch detection circuit of the present invention features operation at frequencies at or above 50kHz and preferably at or above 800 kHz to minimize the effects of surface contamination for materials such a skin oils and water. It also offers improvements in detection sensitivity that allow close control of the degree of proximity (ideally very close proximity) that is required for actuation and to enable employment of a multiplicity of small size touch terminals in a physical close array such as a keyboard.” Col. 5:49-57.</p> <p>The `183 Patent discloses “In a first preferred embodiment the circuit offers enhanced detection sensitivity to allow reliable operation with small (finger size) touch pads.” Col. 6:1-3.</p> <p>The `183 Patent discloses “Although the preferred frequency is at or above 100 kHz, and more preferably at or above 800 kHz, it is conceivable that frequencies as low as 50 kHz could be used provided the frequency creates a difference in the impedance paths of adjacent pads that is sufficient enough to accurately</p>

`183 Patent Claim Language	`183 Patent Support
	<p>distinguish between an intended touch and the touch of an adjacent pad. Us of frequencies as low as 50 kHz may also be possible depending upon the type of glass or covering or the thickness thereof used for the touch pad.” Col. 11:19-27.</p> <p>The `183 Patent discloses “Upon being powered by voltage regulator 100, oscillator 200 generates a square wave with a frequency of 50 kHz, and preferably greater than 800 kHz, and having an amplitude of 26 V peak. The square wave generated by oscillator 200 is supplied via line 201 to a floating common generator 300, a touch pad shield plate 460, a touch circuit 400, and a microcontroller 500. Oscillator 200 is described below with reference to FIG. 6. Floating common generator 300 receives the 26 V peak square wave from oscillator 200 and outputs a regulated floating common that is 5 volts below the square wave output from oscillator 200 and has the same phase and frequency as the received square wave. This floating common output is supplied to touch circuit 400 and microcontroller 500 via line 301 such that the output square wave from oscillator 200 and floating common output from floating common generator 300 provide power to touch circuit 400 and microcontroller 500. Details of floating common generator 300 are discussed below with reference to FIG. 7. Touch circuit 400 senses capacitance from a touch pad 450 via line 451 and outputs a signal to microcontroller 500 via line 401 upon detecting a capacitance to ground at touch pad 450 that exceeds a threshold value. The details of touch circuit 400 are described below with reference to FIG. 8. Upon receiving an indication from touch circuit 400 that a sufficient capacitance to ground (typically at least 20 pF) is present at touch pad 450, microcontroller 500 outputs a signal to a load-controlling microcontroller 600 via line 501, which is preferably a two way optical coupling bus.” Col. 12:6-33.</p>

`183 Patent Claim Language	`183 Patent Support
	<p>The `183 Patent discloses “As will be apparent to those skilled in the art, the values of the resistors and capacitors utilized in oscillator 200 may be varied from those disclosed above to provide for different oscillator output frequencies.” Col. 14:22-25.</p> <p>The `183 Patent discloses “A multiple touch pad circuit constructed in accordance with the second embodiment is shown in FIG. 11. In the second embodiment of FIG. 11, components similar to those in the first embodiment in FIG. 4 are designated with the same references numerals and will not be discussed in detail. The multiple touch pad circuit is a variation of the first embodiment in that it includes an array of touch circuits designated as 900₁ through 900_{nm}, which, as shown, include both the touch circuit 400 shown in FIGS. 4 and 8 and the input touch terminal pad 451 (FIG. 4). Microcontroller 500 selects each row of the touch circuits 900₁ through 900_{nm} by providing the signal from oscillator 200 to selected rows of touch circuits. In this manner, microcontroller 500 can sequentially activate the touch circuit rows and associate the received inputs from the columns of the array with the activated touch circuit(s). To keep the path length 451 between the touch pad 450 and the base to the detection transistor 410 to a minimum, the detection circuits 900 are physically located directly beneath the touch pads. To simplify assembly, a flexible circuit board such as vended by Sheldahl, Inc. or Circuit Etching Technics, Inc. can be used for this purpose. Ideally, the printed circuit will be fixed directly against the surface (typically glass) bearing the conductive touch pads to eliminate air gaps and the need for conductive foam pads and spring contacts which were used to fill air gaps.” Col. 18:34-59.</p>
[a] <u>the plurality of small sized</u> input touch terminals defining adjacent	See Figure 11.

`183 Patent Claim Language	`183 Patent Support
<p>areas on a dielectric substrate for an operator to provide inputs by proximity and touch; and</p>	<p>The `183 Patent discloses “It also offers improvements in detection sensitivity that allow close control of the degree of proximity (ideally very close proximity) that is required for actuation and to enable employment of a multiplicity of small size touch terminals in a physical close array such as a keyboard.” Col. 5:53-57.</p>
<p>a detector circuit coupled to said oscillator for receiving said periodic output signal from said oscillator, and coupled to said input touch terminals, said detector circuit being responsive to signals from said oscillator <u>via said microcontroller</u> and [the] a presence of an operator's body capacitance to ground coupled to said touch terminals when proximal or touched by [an] <u>the</u> operator to provide a control output signal,</p>	<p>See Figures 4, 11; and Claims 8, 12, 16.</p> <p>The `183 Patent discloses The `183 Patent discloses “Upon being powered by voltage regulator 100, oscillator 200 generates a square wave with a frequency of 50 kHz, and preferably greater than 800 kHz, and having an amplitude of 26 V peak. The square wave generated by oscillator 200 is supplied via line 201 to a floating common generator 300, a touch pad shield plate 460, a touch circuit 400, and a microcontroller 500. Oscillator 200 is described below with reference to FIG. 6. Floating common generator 300 receives the 26 V peak square wave from oscillator 200 and outputs a regulated floating common that is 5 volts below the square wave output from oscillator 200 and has the same phase and frequency as the received square wave. This floating common output is supplied to touch circuit 400 and microcontroller 500 via line 301 such that the output square wave from oscillator 200 and floating common output from floating common generator 300 provide power to touch circuit 400 and microcontroller 500. Details of floating common generator 300 are discussed below with reference to FIG. 7. Touch circuit 400 senses capacitance from a touch pad 450 via line 451 and outputs a signal to microcontroller 500 via line 401 upon detecting a capacitance to ground at touch pad 450 that exceeds a threshold value. The details of touch circuit 400 are described below with reference to FIG. 8. Upon receiving an indication from touch circuit 400 that a sufficient capacitance to ground</p>

`183 Patent Claim Language	`183 Patent Support
	<p>(typically at least 20 pF) is present at touch pad 450, microcontroller 500 outputs a signal to a load-controlling microcontroller 600 via line 501, which is preferably a two way optical coupling bus.” Col. 12:6-33.</p> <p>The `183 Patent discloses “A multiple touch pad circuit constructed in accordance with the second embodiment is shown in FIG. 11. In the second embodiment of FIG. 11, components similar to those in the first embodiment in FIG. 4 are designated with the same references numerals and will not be discussed in detail. The multiple touch pad circuit is a variation of the first embodiment in that it includes an array of touch circuits designated as 9001 through 900nm, which, as shown, include both the touch circuit 400 shown in FIGS. 4 and 8 and the input touch terminal pad 451 (FIG. 4). Microcontroller 500 selects each row of the touch circuits 9001 through 900nm by providing the signal from oscillator 200 to selected rows of touch circuits. In this manner, microcontroller 500 can sequentially activate the touch circuit rows and associate the received inputs from the columns of the array with the activated touch circuit(s). To keep the path length 451 between the touch pad 450 and the base to the detection transistor 410 to a minimum, the detection circuits 900 are physically located directly beneath the touch pads. To simplify assembly, a flexible circuit board such as vended by Sheldahl, Inc. or Circuit Etching Technics, Inc. can be used for this purpose. Ideally, the printed circuit will be fixed directly against the surface (typically glass) bearing the conductive touch pads to eliminate air gaps and the need for conductive foam pads and spring contacts which were used to fill air gaps.” Col. 18:34-59.</p>
<p>wherein said predefined frequency of said oscillator [is] <u>and said signal output frequencies are</u> selected to decrease [the] <u>a first</u> impedance of said dielectric</p>	<p>See Figure 11; and Claims 12, 16.</p> <p>The `183 Patent discloses “Another method for implementing capacitive touch switches relies on</p>

`183 Patent Claim Language	`183 Patent Support
<p>substrate relative to [the] <u>a second</u> impedance of any contaminate that may create an electrical path on said dielectric substrate between said adjacent areas <u>defined by the plurality of small sized input touch terminals</u>, and wherein said detector circuit compares [the] <u>a sensed body capacitance change</u> to ground proximate an input touch terminal to a threshold level to prevent inadvertent generation of the control output signal.</p>	<p>the change in capacitive coupling between a touch terminal and ground. Systems utilizing such a method are described in U.S. Pat. No. 4,758,735 and U.S. Pat. No. 5,087,825. With this methodology the detection circuit consists of an oscillator (or AC line voltage derivative) providing a signal to a touch terminal whose voltage is then monitored by a detector. The touch terminal is driven in electrical series with other components that function in part as a charge pump. The touch of an operator then provides a capacitive short to ground via the operator's own body capacitance that lowers the amplitude of oscillator voltage seen at the touch terminal.” Col. 3:44-56.</p> <p>The `183 Patent discloses “The touch detection circuit of the present invention features operation at frequencies at or above 50kHz and preferably at or above 800 kHz to minimize the effects of surface contamination for materials such a skin oils and water. It also offers improvements in detection sensitivity that allow close control of the degree of proximity (ideally very close proximity) that is required for actuation and to enable employment of a multiplicity of small size touch terminals in a physical close array such as a keyboard.” Col. 5:49-57.</p> <p>The `183 Patent discloses “Although the preferred frequency is at or above 100 kHz, and more preferably at or above 800 kHz, it is conceivable that frequencies as low as 50 kHz could be used provided the frequency creates a difference in the impedance paths of adjacent pads that is sufficient enough to accurately distinguish between an intended touch and the touch of an adjacent pad. Us of frequencies as low as 50 kHz may also be possible depending upon the type of glass or covering or the thickness thereof used for the touch pad.” Col. 11:19-27.</p> <p>The `183 Patent discloses “As will be apparent</p>

`183 Patent Claim Language	`183 Patent Support
	to those skilled in the art, the values of the resistors and capacitors utilized in oscillator 200 may be varied from those disclosed above to provide for different oscillator output frequencies.” Col. 14:22-25.

B. Amended Claim 27

`183 Patent Claim Language	`183 Patent Support
27. A capacitive responsive electronic switching circuit for a controlled <u>keypad</u> device comprising:	<p>The `183 Patent discloses “It also offers improvements in detection sensitivity that allow close control of the degree of proximity (ideally very close proximity) that is required for actuation and to enable employment of a multiplicity of small size touch terminals in a physical close array such as a keyboard,” Col. 5:53-57.</p> <p>The `183 Patent discloses “In a first preferred embodiment the circuit offers enhanced detection sensitivity to allow reliable operation with small (finger size) touch pads.” Col. 6:1-3.</p>
an oscillator providing a periodic output signal having a predefined frequency;	--
<u>a microcontroller using the periodic output signal from the oscillator, the microcontroller selectively providing signal output frequencies to a closely spaced array of input touch terminals of a keypad, the input touch terminals comprising first and second input touch terminals;</u>	<p>See Figures 4, 11; and Claims 8, 12, 16.</p> <p>The `183 Patent discloses “The touch detection circuit of the present invention features operation at frequencies at or above 50kHz and preferably at or above 800 kHz to minimize the effects of surface contamination for materials such a skin oils and water. It also offers improvements in detection sensitivity that allow close control of the degree of proximity (ideally very close proximity) that is required for actuation and to enable employment of a multiplicity of small size touch terminals in a physical close array such as a keyboard.” Col. 5:49-57.</p>

`183 Patent Claim Language	`183 Patent Support
	<p>The `183 Patent discloses “In a first preferred embodiment the circuit offers enhanced detection sensitivity to allow reliable operation with small (finger size) touch pads.” Col. 6:1-3.</p> <p>The `183 Patent discloses “Although the preferred frequency is at or above 100 kHz, and more preferably at or above 800 kHz, it is conceivable that frequencies as low as 50 kHz could be used provided the frequency creates a difference in the impedance paths of adjacent pads that is sufficient enough to accurately distinguish between an intended touch and the touch of an adjacent pad. Us of frequencies as low as 50 kHz may also be possible depending upon the type of glass or covering or the thickness thereof used for the touch pad.” Col. 11:19-27.</p> <p>The `183 Patent discloses “Upon being powered by voltage regulator 100, oscillator 200 generates a square wave with a frequency of 50 kHz, and preferably greater than 800 kHz, and having an amplitude of 26 V peak. The square wave generated by oscillator 200 is supplied via line 201 to a floating common generator 300, a touch pad shield plate 460, a touch circuit 400, and a microcontroller 500. Oscillator 200 is described below with reference to FIG. 6. Floating common generator 300 receives the 26 V peak square wave from oscillator 200 and outputs a regulated floating common that is 5 volts below the square wave output from oscillator 200 and has the same phase and frequency as the received square wave. This floating common output is supplied to touch circuit 400 and microcontroller 500 via line 301 such that the output square wave from oscillator 200 and floating common output from floating common generator 300 provide power to touch circuit 400 and microcontroller 500. Details of floating common generator 300 are discussed below with reference to FIG. 7. Touch circuit</p>

`183 Patent Claim Language	`183 Patent Support
	<p>400 senses capacitance from a touch pad 450 via line 451 and outputs a signal to microcontroller 500 via line 401 upon detecting a capacitance to ground at touch pad 450 that exceeds a threshold value. The details of touch circuit 400 are described below with reference to FIG. 8. Upon receiving an indication from touch circuit 400 that a sufficient capacitance to ground (typically at least 20 pF) is present at touch pad 450, microcontroller 500 outputs a signal to a load-controlling microcontroller 600 via line 501, which is preferably a two way optical coupling bus.” Col. 12:6-33.</p> <p>The `183 Patent discloses “As will be apparent to those skilled in the art, the values of the resistors and capacitors utilized in oscillator 200 may be varied from those disclosed above to provide for different oscillator output frequencies.” Col. 14:22-25.</p> <p>The `183 Patent discloses “A multiple touch pad circuit constructed in accordance with the second embodiment is shown in FIG. 11. In the second embodiment of FIG. 11, components similar to those in the first embodiment in FIG. 4 are designated with the same references numerals and will not be discussed in detail. The multiple touch pad circuit is a variation of the first embodiment in that it includes an array of touch circuits designated as 9001 through 900nm, which, as shown, include both the touch circuit 400 shown in FIGS. 4 and 8 and the input touch terminal pad 451 (FIG. 4). Microcontroller 500 selects each row of the touch circuits 9001 through 900nm by providing the signal from oscillator 200 to selected rows of touch circuits. In this manner, microcontroller 500 can sequentially activate the touch circuit rows and associate the received inputs from the columns of the array with the activated touch circuit(s). To keep the path length 451 between the touch pad 450 and the base to the detection transistor 410 to a minimum, the detection circuits 900 are</p>

`183 Patent Claim Language	`183 Patent Support
	<p>physically located directly beneath the touch pads. To simplify assembly, a flexible circuit board such as vended by Sheldahl, Inc. or Circuit Etching Technics, Inc. can be used for this purpose. Ideally, the printed circuit will be fixed directly against the surface (typically glass) bearing the conductive touch pads to eliminate air gaps and the need for conductive foam pads and spring contacts which were used to fill air gaps.” Col. 18:34-59.</p>
<p><u>the</u> first and second <u>input</u> touch terminals defining areas for an operator to provide an input by proximity and touch; and</p>	<p>See Figure 11.</p> <p>The `183 Patent discloses “A multiple touch pad circuit constructed in accordance with the second embodiment is shown in FIG. 11. In the second embodiment of FIG. 11, components similar to those in the first embodiment in FIG. 4 are designated with the same references numerals and will not be discussed in detail. The multiple touch pad circuit is a variation of the first embodiment in that it includes an array of touch circuits designated as 9001 through 900nm, which, as shown, include both the touch circuit 400 shown in FIGS. 4 and 8 and the input touch terminal pad 451 (FIG. 4).” Col. 18:34-43.</p>
<p>a detector circuit coupled to said oscillator for receiving said periodic output signal from said oscillator, and coupled to said first and second touch terminals, said detector circuit being responsive to signals from said oscillator <u>via said microcontroller</u> and [the] <u>a</u> presence of an operator's body capacitance to ground coupled to said first and second touch terminals when proximal or touched by [an] <u>the</u> operator to provide a control output signal for actuation of the controlled <u>keypad</u> device, said detector circuit being configured to generate said control output signal when [an] <u>the</u> operator is proximal or touches said second touch terminal after the operator is</p>	<p>See Figures 4, 11; and Claims 8, 12, 16.</p> <p>The `183 Patent discloses “It also offers improvements in detection sensitivity that allow close control of the degree of proximity (ideally very close proximity) that is required for actuation and to enable employment of a multiplicity of small size touch terminals in a physical close array such as a keyboard,” Col. 5:53-57.</p> <p>The `183 Patent discloses “In a first preferred embodiment the circuit offers enhanced detection sensitivity to allow reliable operation with small (finger size) touch pads.” Col. 6:1-3.</p> <p>The `183 Patent discloses “Upon being powered</p>

`183 Patent Claim Language	`183 Patent Support
<p>proximal or touches said first touch terminal.</p>	<p>by voltage regulator 100, oscillator 200 generates a square wave with a frequency of 50 kHz, and preferably greater than 800 kHz, and having an amplitude of 26 V peak. The square wave generated by oscillator 200 is supplied via line 201 to a floating common generator 300, a touch pad shield plate 460, a touch circuit 400, and a microcontroller 500. Oscillator 200 is described below with reference to FIG. 6. Floating common generator 300 receives the 26 V peak square wave from oscillator 200 and outputs a regulated floating common that is 5 volts below the square wave output from oscillator 200 and has the same phase and frequency as the received square wave. This floating common output is supplied to touch circuit 400 and microcontroller 500 via line 301 such that the output square wave from oscillator 200 and floating common output from floating common generator 300 provide power to touch circuit 400 and microcontroller 500. Details of floating common generator 300 are discussed below with reference to FIG. 7. Touch circuit 400 senses capacitance from a touch pad 450 via line 451 and outputs a signal to microcontroller 500 via line 401 upon detecting a capacitance to ground at touch pad 450 that exceeds a threshold value. The details of touch circuit 400 are described below with reference to FIG. 8. Upon receiving an indication from touch circuit 400 that a sufficient capacitance to ground (typically at least 20 pF) is present at touch pad 450, microcontroller 500 outputs a signal to a load-controlling microcontroller 600 via line 501, which is preferably a two way optical coupling bus.” Col. 12:6-33.</p> <p>The `183 Patent discloses “A multiple touch pad circuit constructed in accordance with the second embodiment is shown in FIG. 11. In the second embodiment of FIG. 11, components similar to those in the first embodiment in FIG. 4 are designated with the same references numerals and will not be discussed in detail. The multiple</p>

`183 Patent Claim Language	`183 Patent Support
	<p>touch pad circuit is a variation of the first embodiment in that it includes an array of touch circuits designated as 9001 through 900nm, which, as shown, include both the touch circuit 400 shown in FIGS. 4 and 8 and the input touch terminal pad 451 (FIG. 4). Microcontroller 500 selects each row of the touch circuits 9001 through 900nm by providing the signal from oscillator 200 to selected rows of touch circuits. In this manner, microcontroller 500 can sequentially activate the touch circuit rows and associate the received inputs from the columns of the array with the activated touch circuit(s). To keep the path length 451 between the touch pad 450 and the base to the detection transistor 410 to a minimum, the detection circuits 900 are physically located directly beneath the touch pads. To simplify assembly, a flexible circuit board such as vended by Sheldahl, Inc. or Circuit Etching Technics, Inc. can be used for this purpose. Ideally, the printed circuit will be fixed directly against the surface (typically glass) bearing the conductive touch pads to eliminate air gaps and the need for conductive foam pads and spring contacts which were used to fill air gaps.” Col. 18:34-59.</p>

C. Amended Claim 28

`183 Patent Claim Language	`183 Patent Support
<p>28. The capacitive responsive electronic switching circuit as defined in claim 27, wherein said detector circuit generates said control signal only when [an] <u>the</u> operator is proximal or touches said second touch terminal within a predetermined time period after the operator is proximal or touches said first touch terminal.</p>	<p>The amendment does not substantively change original claim 28.</p>

D. Amended Claim 32

`183 Patent Claim Language	`183 Patent Support
<p>32. The capacitive responsive electronic switching circuit as defined in claim 27 and further including an indicator for indicating when said detector circuit determines that [an] <u>the</u> operator is proximal or touches said first touch terminal.</p>	<p>The amendment does not substantively change original claim 32.</p>

E. New Claim 33

`183 Patent Claim Language	`183 Patent Support
<p>33. The capacitive responsive electronic switching circuit as defined in claim 18, further comprising wherein said detector circuit compares the sensed body capacitance change caused by the body capacitance decreasing an input touch terminal signal on the detector to ground when proximate to the input touch terminal to a second threshold level to generate the control output signal.</p>	<p>See Claims 1, 18, 28.</p> <p>The `183 Patent discloses “The touch detection circuit of the present invention features operation at frequencies at or above 50kHz and preferably at or above 800 kHz to minimize the effects of surface contamination for materials such a skin oils and water. It also offers improvements in detection sensitivity that allow close control of the degree of proximity (ideally very close proximity) that is required for actuation and to enable employment of a multiplicity of small size touch terminals in a physical close array such as a keyboard.” Col. 5:49-57.</p> <p>The `183 Patent discloses “Touch circuit 400 senses capacitance from a touch pad 450 via line 451 and outputs a signal to microcontroller 500 via line 401 upon detecting a capacitance to ground at touch pad 450 that exceeds a threshold value. The details of touch circuit 400 are described below with reference to FIG. 8.” Col. 12:24-28.</p>

F. New Claim 34

`183 Patent Claim Language	`183 Patent Support
<p>34. The capacitive responsive electronic switching circuit as defined in claim 18, further comprising wherein said detector circuit compares the sensed body capacitance change caused by the body capacitance decreasing an input touch terminal signal amplitude on the detector to ground when proximate to the input touch terminal to a second threshold level to generate the control output signal.</p>	<p>See Claims 1, 18, 28.</p> <p>The `183 Patent discloses “Another method for implementing capacitive touch switches relies on the change in capacitive coupling between a touch terminal and ground. Systems utilizing such a method are described in U.S. Pat. No. 4,758,735 and U.S. Pat. No. 5,087,825. With this methodology the detection circuit consists of an oscillator (or AC line voltage derivative) providing a signal to a touch terminal whose voltage is then monitored by a detector. The touch terminal is driven in electrical series with other components that function in part as a charge pump. The touch of an operator then provides a capacitive short to ground via the operator's own body capacitance that lowers the amplitude of oscillator voltage seen at the touch terminal.” Col. 3:44-56.</p> <p>The `183 Patent discloses “The touch detection circuit of the present invention features operation at frequencies at or above 50kHz and preferably at or above 800 kHz to minimize the effects of surface contamination for materials such a skin oils and water. It also offers improvements in detection sensitivity that allow close control of the degree of proximity (ideally very close proximity) that is required for actuation and to enable employment of a multiplicity of small size touch terminals in a physical close array such as a keyboard.” Col. 5:49-57.</p> <p>The `183 Patent discloses “Touch circuit 400 senses capacitance from a touch pad 450 via line 451 and outputs a signal to microcontroller 500 via line 401 upon detecting a capacitance to ground at touch pad 450 that exceeds a threshold value. The details of touch circuit 400 are described below with reference to FIG. 8.” Col. 12:24-28.</p>

G. New Claim 35

`183 Patent Claim Language	`183 Patent Support
<p>35. The capacitive responsive electronic switching circuit as defined in claim 27, wherein when the second touch terminal is not touched on its defining area by the operator to provide input, the control output signal is prevented.</p>	<p>See Figures 19, 20A-C; and Claim 28.</p> <p>The `183 Patent discloses “In another embodiment a method to prevent inadvertent so actuations is to require a multi-step process. Referring to FIG. 19, a device is shown having a first palm button 2201, a second palm button 2202, and an indicator light 2205. Palm button 2201 has to be activated first and then button 2202 has to be activated within a 2 second time window before a desired actuation can occur.” Col. 22:49-55.</p> <p>The `183 Patent discloses “In a variation of the multi-step process, two touch plates within a housing (one vertical and one horizontal) are used to provide a two-step turn-on. Referring to FIGS. 20A-C, the first step to actuate the output relay 2310, is initiated when the operator inserts his hands and touches the vertical touch sensor 2301 with the dorsal side of the hands. A yellow LED 2304 on top of the device show the successful completion of the first step. The second step is to flip the hand over and touch the horizontal touch sensor 2302 with the palmar side of the hand. A red LED 2305 on top of the device shows the completion of the two step turn-on and activation of output relay 2310. The flipping action of the hand in the second step causes the forearm muscles to flex, thereby reducing stiffness and fatigue. Also, the hands, and arms can rest on the run bar until the machine cycle is complete. The second step of the two-step turn-on must occur within some predetermined time (for example 2 seconds) after the release of vertical touch sensor or the first step must be repeated.” Col. 23:19-36.</p>

H. New Claim 36

`183 Patent Claim Language	`183 Patent Support
<p>36. The capacitive responsive electronic switching circuit as defined in claim 27 and further including an indicator for indicating when said detector circuit determines that the operator is proximal or touches said second touch terminal.</p>	<p>See Claim 32.</p> <p>The `183 Patent discloses “The microprocessor also allows the use of visual indicators such as LEDs or annunciators such as a bell or tone generator to confirm the actuation of a given touch switch or switches. This is particularly useful in cases where a sequence of actuations is required before an action occurs. The feedback to the operator provided by a visual or audio indicator activated by the microprocessor in response to intermediate touches in a required sequence can minimize time lost and/or frustration on the part of the operator due to failed actuations from partial touches or wrong actuations from touching the wrong pad in a given required sequence or combination of touches.” Col. 6:31-42.</p> <p>The `183 Patent discloses “A further option is to provide one or more LEDs 2205 or audible annunciators for visual or audible feedback to the operator. Specifically, in FIG. 19 the LED 2205 will come on when button 2201 has been successfully activated to cue the operator that it is time to move to button 2202. Where required a second LED with a different color than the first (yellow for the first LED and red for the second) can be provided to provide visual confirmation that the second button 2202 has been activated or that the required combination of the two buttons has been activated. Two different audible tone or sound generators could also be used in lieu of the LEDs to provide feedback to the operator.” Col. 23:1-12.</p> <p>The `183 Patent discloses “A red LED 2305 on top of the device shows the completion of the two step tum-on and activation of output relay 2310.” Col. 23:28-30.</p>

I. New Claim 37

For ease of analysis, new independent claim 37 is shown below with pseudo-amendments illustrating the differences between new claim 37 and original claim 27 of the `183 Patent.

`183 Patent Claim Language	`183 Patent Support
<p>37. A capacitive responsive electronic switching circuit for a controlled device comprising:</p>	<p>See Claim 27.</p>
<p>an oscillator providing a periodic output signal having a predefined frequency, <u>wherein an oscillator voltage is greater than a supply voltage;</u></p>	<p>See Figures 4, 5; and Claim 27.</p> <p>The `183 Patent discloses “Having provided a basis for the use of higher frequencies the basic construction of the electronic switching circuit constructed in accordance with a first embodiment of the present invention is now described with reference to FIG. 4. The electronic switching circuit includes a voltage regulator 100 including input lines 101 and 102 for receiving a 24 V AC line voltage and a line 103 for grounding the circuit. Voltage regulator 100 converts the received AC voltage to a DC voltage and supplies a regulated 5 V DC power to an oscillator 200 via lines 104 and 105. Voltage regulator also supplies oscillator 200 with 26 V DC power via line 106. The details of voltage regulator 100 are discussed below with reference to FIG. 5.” Col. 11:60-Col. 12:5.</p> <p>The `183 Patent discloses “A preferred circuit for implementing a voltage regulator 100 is shown in FIG. 5. Voltage regulator 100 preferably includes an AC/DC convertor 110 for generating 29 V to 36 V unregulated DC on line 119. This unregulated DC power is supplied to a 5 V DC regulator 120 and to a 26 V DC regulator 130. AC/DC convertor 110 includes diodes 112, 114, 116, and 118, which rectify the supplied 24 V AC power provided on power lines 101 and 102.” Col. 12:50-57; see also Col. 12:58-Col. 13:31.</p> <p>The `183 Patent discloses “The oscillator</p>

`183 Patent Claim Language	`183 Patent Support
	<p>circuitry shown in FIG. 6 is very stable over the temperature range of -40° C. to 105° C. The output of the touch switch circuitry drops at a rate of approximately 40 mV/°C when temperature falls below 0° C. If application requires operation at low temperatures (-40° C.) the following three methods may be used to increase the output of the switch: increase the oscillator's regulated supply voltage, increase the resistance of resistor 416, and use a 40 higher gain transistor 410. All of these methods would increase sensitivity at high temperatures.” Col. 16:33-41.</p>
<p><u>a microcontroller using the periodic output signal from the oscillator, the microcontroller selectively providing signal output frequencies to a closely spaced array of input touch terminals of a keypad, the input touch terminals comprising first and second input touch terminals;</u></p>	<p>See Figures 4, 11; and Claims 8, 12, 16, 27.</p> <p>The `183 Patent discloses “The touch detection circuit of the present invention features operation at frequencies at or above 50kHz and preferably at or above 800 kHz to minimize the effects of surface contamination for materials such a skin oils and water. It also offers improvements in detection sensitivity that allow close control of the degree of proximity (ideally very close proximity) that is required for actuation and to enable employment of a multiplicity of small size touch terminals in a physical close array such as a keyboard.” Col. 5:49-57.</p> <p>The `183 Patent discloses “In a first preferred embodiment the circuit offers enhanced detection sensitivity to allow reliable operation with small (finger size) touch pads.” Col. 6:1-3.</p> <p>The `183 Patent discloses “Although the preferred frequency is at or above 100 kHz, and more preferably at or above 800 kHz, it is conceivable that frequencies as low as 50 kHz could be used provided the frequency creates a difference in the impedance paths of adjacent pads that is sufficient enough to accurately distinguish between an intended touch and the touch of an adjacent pad. Us of frequencies as low as 50 kHz may also be possible depending</p>

`183 Patent Claim Language	`183 Patent Support
	<p>upon the type of glass or covering or the thickness thereof used for the touch pad.” Col. 11:19-27.</p> <p>The `183 Patent discloses “Upon being powered by voltage regulator 100, oscillator 200 generates a square wave with a frequency of 50 kHz, and preferably greater than 800 kHz, and having an amplitude of 26 V peak. The square wave generated by oscillator 200 is supplied via line 201 to a floating common generator 300, a touch pad shield plate 460, a touch circuit 400, and a microcontroller 500. Oscillator 200 is described below with reference to FIG. 6. Floating common generator 300 receives the 26 V peak square wave from oscillator 200 and outputs a regulated floating common that is 5 volts below the square wave output from oscillator 200 and has the same phase and frequency as the received square wave. This floating common output is supplied to touch circuit 400 and microcontroller 500 via line 301 such that the output square wave from oscillator 200 and floating common output from floating common generator 300 provide power to touch circuit 400 and microcontroller 500. Details of floating common generator 300 are discussed below with reference to FIG. 7. Touch circuit 400 senses capacitance from a touch pad 450 via line 451 and outputs a signal to microcontroller 500 via line 401 upon detecting a capacitance to ground at touch pad 450 that exceeds a threshold value. The details of touch circuit 400 are described below with reference to FIG. 8. Upon receiving an indication from touch circuit 400 that a sufficient capacitance to ground (typically at least 20 pF) is present at touch pad 450, microcontroller 500 outputs a signal to a load-controlling microcontroller 600 via line 501, which is preferably a two way optical coupling bus.” Col. 12:6-33.</p> <p>The `183 Patent discloses “As will be apparent to those skilled in the art, the values of the</p>

`183 Patent Claim Language	`183 Patent Support
	<p>resistors and capacitors utilized in oscillator 200 may be varied from those disclosed above to provide for different oscillator output frequencies.” Col. 14:22-25.</p> <p>The `183 Patent discloses “A multiple touch pad circuit constructed in accordance with the second embodiment is shown in FIG. 11. In the second embodiment of FIG. 11, components similar to those in the first embodiment in FIG. 4 are designated with the same references numerals and will not be discussed in detail. The multiple touch pad circuit is a variation of the first embodiment in that it includes an array of touch circuits designated as 9001 through 900nm, which, as shown, include both the touch circuit 400 shown in FIGS. 4 and 8 and the input touch terminal pad 451 (FIG. 4). Microcontroller 500 selects each row of the touch circuits 9001 through 900nm by providing the signal from oscillator 200 to selected rows of touch circuits. In this manner, microcontroller 500 can sequentially activate the touch circuit rows and associate the received inputs from the columns of the array with the activated touch circuit(s). To keep the path length 451 between the touch pad 450 and the base to the detection transistor 410 to a minimum, the detection circuits 900 are physically located directly beneath the touch pads. To simplify assembly, a flexible circuit board such as vended by Sheldahl, Inc. or Circuit Etching Technics, Inc. can be used for this purpose. Ideally, the printed circuit will be fixed directly against the surface (typically glass) bearing the conductive touch pads to eliminate air gaps and the need for conductive foam pads and spring contacts which were used to fill air gaps.” Col. 18:34-59.</p>
<p><u>the</u> first and second touch terminals defining areas for an operator to provide an input by proximity and touch; and</p>	<p>See Claim 27.</p>

`183 Patent Claim Language	`183 Patent Support
<p>a detector circuit coupled to said oscillator for receiving said periodic output signal from said oscillator, and coupled to said first and second touch terminals, said detector circuit being responsive to signals from said oscillator via said microcontroller and [the] a presence of an operator's body capacitance to ground coupled to said first and second touch terminals when proximal or touched by [an] the operator to provide a control output signal for actuation of the controlled device, said detector circuit being configured to generate said control output signal when [an] the operator is proximal or touches said second touch terminal after the operator is proximal or touches said first touch terminal.</p>	<p>See Figures 4, 11; and Claims 8, 12, 16, 27.</p> <p>The `183 Patent discloses “Upon being powered by voltage regulator 100, oscillator 200 generates a square wave with a frequency of 50 kHz, and preferably greater than 800 kHz, and having an amplitude of 26 V peak. The square wave generated by oscillator 200 is supplied via line 201 to a floating common generator 300, a touch pad shield plate 460, a touch circuit 400, and a microcontroller 500. Oscillator 200 is described below with reference to FIG. 6. Floating common generator 300 receives the 26 V peak square wave from oscillator 200 and outputs a regulated floating common that is 5 volts below the square wave output from oscillator 200 and has the same phase and frequency as the received square wave. This floating common output is supplied to touch circuit 400 and microcontroller 500 via line 301 such that the output square wave from oscillator 200 and floating common output from floating common generator 300 provide power to touch circuit 400 and microcontroller 500. Details of floating common generator 300 are discussed below with reference to FIG. 7. Touch circuit 400 senses capacitance from a touch pad 450 via line 451 and outputs a signal to microcontroller 500 via line 401 upon detecting a capacitance to ground at touch pad 450 that exceeds a threshold value. The details of touch circuit 400 are described below with reference to FIG. 8. Upon receiving an indication from touch circuit 400 that a sufficient capacitance to ground (typically at least 20 pF) is present at touch pad 450, microcontroller 500 outputs a signal to a load-controlling microcontroller 600 via line 501, which is preferably a two way optical coupling bus.” Col. 12:6-33.</p> <p>The `183 Patent discloses “A multiple touch pad circuit constructed in accordance with the second embodiment is shown in FIG. 11. In the second embodiment of FIG. 11, components similar to</p>

`183 Patent Claim Language	`183 Patent Support
	<p>those in the first embodiment in FIG. 4 are designated with the same references numerals and will not be discussed in detail. The multiple touch pad circuit is a variation of the first embodiment in that it includes an array of touch circuits designated as 9001 through 900nm, which, as shown, include both the touch circuit 400 shown in FIGS. 4 and 8 and the input touch terminal pad 451 (FIG. 4). Microcontroller 500 selects each row of the touch circuits 9001 through 900nm by providing the signal from oscillator 200 to selected rows of touch circuits. In this manner, microcontroller 500 can sequentially activate the touch circuit rows and associate the received inputs from the columns of the array with the activated touch circuit(s). To keep the path length 451 between the touch pad 450 and the base to the detection transistor 410 to a minimum, the detection circuits 900 are physically located directly beneath the touch pads. To simplify assembly, a flexible circuit board such as vended by Sheldahl, Inc. or Circuit Etching Technics, Inc. can be used for this purpose. Ideally, the printed circuit will be fixed directly against the surface (typically glass) bearing the conductive touch pads to eliminate air gaps and the need for conductive foam pads and spring contacts which were used to fill air gaps.” Col. 18:34-59.</p>

J. New Claim 38

`183 Patent Claim Language	`183 Patent Support
<p>38. The capacitive responsive electronic switching circuit as defined in claim 37, wherein feedback to the operator is provided by an indicator activated by the microcontroller after the operator touches the second touch terminal.</p>	<p>See Claims 27, 32.</p> <p>The `183 Patent discloses “The microprocessor also allows the use of visual indicators such as LEDs or annunciators such as a bell or tone generator to confirm the actuation of a given touch switch or switches. This is particularly useful in cases where a sequence of actuations is required before an action occurs. The feedback</p>

`183 Patent Claim Language	`183 Patent Support
	<p>to the operator provided by a visual or audio indicator activated by the microprocessor in response to intermediate touches in a required sequence can minimize time lost and/or frustration on the part of the operator due to failed actuations from partial touches or wrong actuations from touching the wrong pad in a given required sequence or combination of touches.” Col. 6:31-42.</p> <p>The `183 Patent discloses “A further option is to provide one or more LEDs 2205 or audible annunciators for visual or audible feedback to the operator. Specifically, in FIG. 19 the LED 2205 will come on when button 2201 has been successfully activated to cue the operator that it is time to move to button 2202. Where required a second LED with a different color than the first (yellow for the first LED and red for the second) can be provided to provide visual confirmation that the second button 2202 has been activated or that the required combination of the two buttons has been activated. Two different audible tone or sound generators could also be used in lieu of the LEDs to provide feedback to the operator.” Col. 23:1-12.</p> <p>The `183 Patent discloses “A red LED 2305 on top of the device shows the completion of the two step tum-on and activation of output relay 2310.” Col. 23:28-30.</p>

K. New Claim 39

`183 Patent Claim Language	`183 Patent Support
39. The capacitive responsive electronic switching circuit as defined in claim 37,	Claim 27.
wherein said detector circuit compares a sensed body capacitance change caused by the body capacitance	See Figure 11; and Claims 1, 12, 16, 18, 27, 28. The `183 Patent discloses “Another method for

`183 Patent Claim Language	`183 Patent Support
<p>decreasing a second touch terminal signal on the detector to ground when proximate to the second touch terminal to a threshold level to generate the control output signal, and</p>	<p>implementing capacitive touch switches relies on the change in capacitive coupling between a touch terminal and ground. Systems utilizing such a method are described in U.S. Pat. No. 4,758,735 and U.S. Pat. No. 5,087,825. With this methodology the detection circuit consists of an oscillator (or AC line voltage derivative) providing a signal to a touch terminal whose voltage is then monitored by a detector. The touch terminal is driven in electrical series with other components that function in part as a charge pump. The touch of an operator then provides a capacitive short to ground via the operator's own body capacitance that lowers the amplitude of oscillator voltage seen at the touch terminal.” Col. 3:44-56.</p> <p>The `183 Patent discloses “The touch detection circuit of the present invention features operation at frequencies at or above 50kHz and preferably at or above 800 kHz to minimize the effects of surface contamination for materials such a skin oils and water. It also offers improvements in detection sensitivity that allow close control of the degree of proximity (ideally very close proximity) that is required for actuation and to enable employment of a multiplicity of small size touch terminals in a physical close array such as a keyboard.” Col. 5:49-57.</p> <p>The `183 Patent discloses “Although the preferred frequency is at or above 100 kHz, and more preferably at or above 800 kHz, it is conceivable that frequencies as low as 50 kHz could be used provided the frequency creates a difference in the impedance paths of adjacent pads that is sufficient enough to accurately distinguish between an intended touch and the touch of an adjacent pad. Us of frequencies as low as 50 kHz may also be possible depending upon the type of glass or covering or the thickness thereof used for the touch pad.” Col. 11:19-27.</p>

`183 Patent Claim Language	`183 Patent Support
	<p>The `183 Patent discloses “Touch circuit 400 senses capacitance from a touch pad 450 via line 451 and outputs a signal to microcontroller 500 via line 401 upon detecting a capacitance to ground at touch pad 450 that exceeds a threshold value. The details of touch circuit 400 are described below with reference to FIG. 8.” Col. 12:24-28.</p> <p>The `183 Patent discloses “As will be apparent to those skilled in the art, the values of the resistors and capacitors utilized in oscillator 200 may be varied from those disclosed above to provide for different oscillator output frequencies.” Col. 14:22-25.</p>
<p>wherein feedback to the operator is provided by an indicator activated by the microcontroller after the operator touches the second touch terminal.</p>	<p>See Claims 27, 32.</p> <p>The `183 Patent discloses “The microprocessor also allows the use of visual indicators such as LEDs or annunciators such as a bell or tone generator to confirm the actuation of a given touch switch or switches. This is particularly useful in cases where a sequence of actuations is required before an action occurs. The feedback to the operator provided by a visual or audio indicator activated by the microprocessor in response to intermediate touches in a required sequence can minimize time lost and/or frustration on the part of the operator due to failed actuations from partial touches or wrong actuations from touching the wrong pad in a given required sequence or combination of touches.” Col. 6:31-42.</p> <p>The `183 Patent discloses “A further option is to provide one or more LEDs 2205 or audible annunciators for visual or audible feedback to the operator. Specifically, in FIG. 19 the LED 2205 will come on when button 2201 has been successfully activated to cue the operator that it is time to move to button 2202. Where required a second LED with a different color than the first (yellow for the first LED and red for the second)</p>

`183 Patent Claim Language	`183 Patent Support
	<p>can be provided to provide visual confirmation that the second button 2202 has been activated or that the required combination of the two buttons has been activated. Two different audible tone or sound generators could also be used in lieu of the LEDs to provide feedback to the operator.” Col. 23:1-12.</p> <p>The `183 Patent discloses “A red LED 2305 on top of the device shows the completion of the two step tum-on and activation of output relay 2310.” Col. 23:28-30.</p>

V. Conclusion

In view of the above, Patent Owner submits that the claims are in condition for allowance. No new matter has been added by this submission. If Examiner should have any questions, please contact Patent Owner's Attorney, Brian A. Carlson, at 972-732-1001. The Commissioner is hereby authorized to charge any fees due in connection with this filing, or credit any overpayment, to Deposit Account No. 50-1065.

Respectfully submitted,

November 19, 2012 _____
Date

/Brian A. Carlson/ _____
Brian A. Carlson
Attorney for Patent Owner
Reg. No. 37,793

SLATER & MATSIL, L.L.P.
17950 Preston Rd., Suite 1000
Dallas, Texas 75252
Tel.: 972-732-1001
Fax: 972-732-9218

Electronic Patent Application Fee Transmittal

Application Number:	90012439			
Filing Date:	17-Aug-2012			
Title of Invention:	Capacitive Responsive Electronic Switching Circuit			
First Named Inventor/Applicant Name:	5796183			
Filer:	Brian A. Carlson/Michelle Hatcher			
Attorney Docket Number:	NAR-5796183RX			
Filed as Large Entity				
ex parte reexam Filing Fees				
Description	Fee Code	Quantity	Amount	Sub-Total in USD(\$)
Basic Filing:				
Pages:				
Claims:				
Reexamination Independent Claims	1821	1	250	250
Reexamination claims in excess of 20	1822	3	62	186
Miscellaneous-Filing:				
Petition:				
Patent-Appeals-and-Interference:				
Post-Allowance-and-Post-Issuance:				

Description	Fee Code	Quantity	Amount	Sub-Total in USD(\$)
Extension-of-Time:				
Miscellaneous:				
Total in USD (\$)				436

Electronic Acknowledgement Receipt

EFS ID:	14267867
Application Number:	90012439
International Application Number:	
Confirmation Number:	4155
Title of Invention:	Capacitive Responsive Electronic Switching Circuit
First Named Inventor/Applicant Name:	5796183
Customer Number:	25962
Filer:	Brian A. Carlson/Michelle Hatcher
Filer Authorized By:	Brian A. Carlson
Attorney Docket Number:	NAR-5796183RX
Receipt Date:	19-NOV-2012
Filing Date:	17-AUG-2012
Time Stamp:	17:13:34
Application Type:	Reexam (Patent Owner)

Payment information:

Submitted with Payment	yes
Payment Type	Deposit Account
Payment was successfully received in RAM	\$436
RAM confirmation Number	5429
Deposit Account	501065
Authorized User	

The Director of the USPTO is hereby authorized to charge indicated fees and credit any overpayment as follows:

- Charge any Additional Fees required under 37 C.F.R. Section 1.16 (National application filing, search, and examination fees)
- Charge any Additional Fees required under 37 C.F.R. Section 1.17 (Patent application and reexamination processing fees)

File Listing:					
Document Number	Document Description	File Name	File Size(Bytes)/ Message Digest	Multi Part /.zip	Pages (if appl.)
1	Reexam Timely Patent Owner's Stmtnt in Resp to Order	NAR_5796183RX_PatentOwner Statement.pdf	162005 <small>85f95817488b5057290fde7fa3874998251aadc</small>	no	37
Warnings:					
Information:					
2	Fee Worksheet (SB06)	fee-info.pdf	31575 <small>49b7d87fe8985d4a57903154d3764c47396547d</small>	no	2
Warnings:					
Information:					
Total Files Size (in bytes):			193580		
<p>This Acknowledgement Receipt evidences receipt on the noted date by the USPTO of the indicated documents, characterized by the applicant, and including page counts, where applicable. It serves as evidence of receipt similar to a Post Card, as described in MPEP 503.</p> <p><u>New Applications Under 35 U.S.C. 111</u> If a new application is being filed and the application includes the necessary components for a filing date (see 37 CFR 1.53(b)-(d) and MPEP 506), a Filing Receipt (37 CFR 1.54) will be issued in due course and the date shown on this Acknowledgement Receipt will establish the filing date of the application.</p> <p><u>National Stage of an International Application under 35 U.S.C. 371</u> If a timely submission to enter the national stage of an international application is compliant with the conditions of 35 U.S.C. 371 and other applicable requirements a Form PCT/DO/EO/903 indicating acceptance of the application as a national stage submission under 35 U.S.C. 371 will be issued in addition to the Filing Receipt, in due course.</p> <p><u>New International Application Filed with the USPTO as a Receiving Office</u> If a new international application is being filed and the international application includes the necessary components for an international filing date (see PCT Article 11 and MPEP 1810), a Notification of the International Application Number and of the International Filing Date (Form PCT/RO/105) will be issued in due course, subject to prescriptions concerning national security, and the date shown on this Acknowledgement Receipt will establish the international filing date of the application.</p>					



UNITED STATES PATENT AND TRADEMARK OFFICE

UNITED STATES DEPARTMENT OF COMMERCE
United States Patent and Trademark Office
Address: COMMISSIONER FOR PATENTS
P.O. Box 1450
Alexandria, Virginia 22313-1450
www.uspto.gov

APPLICATION NUMBER	FILING OR 371(C) DATE	FIRST NAMED APPLICANT	ATTY. DOCKET NO./TITLE
90/012,439	08/17/2012	5796183	5796183RX

CONFIRMATION NO. 4155

POWER OF ATTORNEY NOTICE

22045
BROOKS KUSHMAN P.C.
1000 TOWN CENTER
TWENTY-SECOND FLOOR
SOUTHFIELD, MI 48075



Date Mailed: 10/11/2012

NOTICE REGARDING CHANGE OF POWER OF ATTORNEY

This is in response to the Power of Attorney filed 09/28/2012.

- The Power of Attorney to you in this application has been revoked by the assignee who has intervned as provided by 37 CFR 3.71. Future correspondence will be mailed to the new address of record(37 CFR 1.33).

/sdstevenson/

Office of Data Management, Application Assistance Unit (571) 272-4000, or (571) 272-4200, or 1-888-786-0101



UNITED STATES PATENT AND TRADEMARK OFFICE

UNITED STATES DEPARTMENT OF COMMERCE
United States Patent and Trademark Office
Address: COMMISSIONER FOR PATENTS
P.O. Box 1450
Alexandria, Virginia 22313-1450
www.uspto.gov

APPLICATION NUMBER	FILING OR 371(C) DATE	FIRST NAMED APPLICANT	ATTY. DOCKET NO./TITLE
90/012,439	08/17/2012	5796183	5796183RX

CONFIRMATION NO. 4155

POA ACCEPTANCE LETTER

25962
SLATER & MATSIL, L.L.P.
17950 PRESTON RD, SUITE 1000
DALLAS, TX 75252-5793



OC000000056994055

Date Mailed: 10/11/2012

NOTICE OF ACCEPTANCE OF POWER OF ATTORNEY

This is in response to the Power of Attorney filed 09/28/2012.

The Power of Attorney in this application is accepted. Correspondence in this application will be mailed to the above address as provided by 37 CFR 1.33.

/sdstevenson/

Office of Data Management, Application Assistance Unit (571) 272-4000, or (571) 272-4200, or 1-888-786-0101



UNITED STATES PATENT AND TRADEMARK OFFICE

UNITED STATES DEPARTMENT OF COMMERCE
 United States Patent and Trademark Office
 Address: COMMISSIONER FOR PATENTS
 P.O. Box 1450
 Alexandria, Virginia 22313-1450
 www.uspto.gov



Bib Data Sheet

CONFIRMATION NO. 4155

SERIAL NUMBER 90/012,439	FILING OR 371(c) DATE 08/17/2012 RULE	CLASS 307	GROUP ART UNIT 3992	ATTORNEY DOCKET NO. 5796183RX	
APPLICANTS 5796183, Residence Not Provided; OWNER, REED CITY, MI; PATENT OWNER, REED CITY, MI;					
** CONTINUING DATA ***** This application is a REX of 08/601,268 01/31/1996 PAT 5796183					
** FOREIGN APPLICATIONS *****					
Foreign Priority claimed <input type="checkbox"/> yes <input type="checkbox"/> no		STATE OR COUNTRY	SHEETS DRAWING	TOTAL CLAIMS 32	INDEPENDENT CLAIMS 8
35 USC 119 (a-d) conditions <input type="checkbox"/> yes <input type="checkbox"/> no <input type="checkbox"/> Met after met Allowance					
Verified and Acknowledged		Examiner's Signature _____		Initials _____	
ADDRESS 25962					
TITLE Capacitive Responsive Electronic Switching Circuit					
FILING FEE RECEIVED 2520	FEES: Authority has been given in Paper No. _____ to charge/credit DEPOSIT ACCOUNT No. _____ for following:		<input type="checkbox"/> All Fees <input type="checkbox"/> 1.16 Fees (Filing) <input type="checkbox"/> 1.17 Fees (Processing Ext. of time) <input type="checkbox"/> 1.18 Fees (Issue) <input type="checkbox"/> Other _____ <input type="checkbox"/> Credit		

Under the Paperwork Reduction Act of 1995, no persons are required to respond to a collection of information unless it displays a valid OMB control number.

POWER OF ATTORNEY TO PROSECUTE APPLICATIONS BEFORE THE USPTO

I hereby revoke all previous powers of attorney given in the application identified in the attached statement under 37 CFR 3.73(b).

I hereby appoint:

Practitioners associated with the Customer Number: 25962

OR

Practitioner(s) named below (if more than ten patent practitioners are to be named, then a customer number must be used):

Name	Registration Number	Name	Registration Number

as attorney(s) or agent(s) to represent the undersigned before the United States Patent and Trademark Office (USPTO) in connection with any and all patent applications assigned only to the undersigned according to the USPTO assignment records or assignment documents attached to this form in accordance with 37 CFR 3.73(b).

Please change the correspondence address for the application identified in the attached statement under 37 CFR 3.73(b) to:

The address associated with Customer Number: 25962

OR

<input type="checkbox"/> Firm or Individual Name			
Address			
City	State	Zip	
Country			
Telephone	Email		

Assignee Name and Address:

UUSI, LLC
 5000 North US Highway 131, Twenty-Second Floor
 Reed City, Michigan 49677

A copy of this form, together with a statement under 37 CFR 3.73(b) (Form PTO/SB/96 or equivalent) is required to be filed in each application in which this form is used. The statement under 37 CFR 3.73(b) may be completed by one of the practitioners appointed in this form if the appointed practitioner is authorized to act on behalf of the assignee, and must identify the application in which this Power of Attorney is to be filed.

SIGNATURE of Assignee of Record

The individual whose signature and title is supplied below is authorized to act on behalf of the assignee

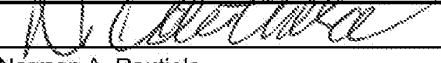
Signature		Date	9-26-12
Name	Norman A. Rautiola	Telephone	231-832-5525
Title	Manager		

This collection of information is required by 37 CFR 1.31, 1.32 and 1.33. The information is required to obtain or retain a benefit by the public which is to file (and by the USPTO to process) an application. Confidentiality is governed by 35 U.S.C. 122 and 37 CFR 1.11 and 1.14. This collection is estimated to take 3 minutes to complete, including gathering, preparing, and submitting the completed application form to the USPTO. Time will vary depending upon the individual case. Any comments on the amount of time you require to complete this form and/or suggestions for reducing this burden, should be sent to the Chief Information Officer, U.S. Patent and Trademark Office, U.S. Department of Commerce, P.O. Box 1450, Alexandria, VA 22313-1450. DO NOT SEND FEES OR COMPLETED FORMS TO THIS ADDRESS. SEND TO: Commissioner for Patents, P.O. Box 1450, Alexandria, VA 22313-1450.

If you need assistance in completing the form, call 1-800-PTO-9199 and select option 2.

Electronic Acknowledgement Receipt

EFS ID:	13863857
Application Number:	90012439
International Application Number:	
Confirmation Number:	4155
Title of Invention:	Capacitive Responsive Electronic Switching Circuit
First Named Inventor/Applicant Name:	5796183
Customer Number:	22045
Filer:	Brian A. Carlson
Filer Authorized By:	
Attorney Docket Number:	5796183RX
Receipt Date:	28-SEP-2012
Filing Date:	17-AUG-2012
Time Stamp:	12:18:04
Application Type:	Reexam (Patent Owner)

Payment information:

Submitted with Payment	no
------------------------	----

File Listing:

Document Number	Document Description	File Name	File Size(Bytes)/ Message Digest	Multi Part /.zip	Pages (if appl.)
1	Power of Attorney	5796183RX_PowerOfAttorney.pdf	1473545 <small>9ef4a2f2655441d3a34594d5746470668d9a4c18</small>	no	1

Warnings:

Information:

Total Files Size (in bytes):

1473545

This Acknowledgement Receipt evidences receipt on the noted date by the USPTO of the indicated documents, characterized by the applicant, and including page counts, where applicable. It serves as evidence of receipt similar to a Post Card, as described in MPEP 503.

New Applications Under 35 U.S.C. 111

If a new application is being filed and the application includes the necessary components for a filing date (see 37 CFR 1.53(b)-(d) and MPEP 506), a Filing Receipt (37 CFR 1.54) will be issued in due course and the date shown on this Acknowledgement Receipt will establish the filing date of the application.

National Stage of an International Application under 35 U.S.C. 371

If a timely submission to enter the national stage of an international application is compliant with the conditions of 35 U.S.C. 371 and other applicable requirements a Form PCT/DO/EO/903 indicating acceptance of the application as a national stage submission under 35 U.S.C. 371 will be issued in addition to the Filing Receipt, in due course.

New International Application Filed with the USPTO as a Receiving Office

If a new international application is being filed and the international application includes the necessary components for an international filing date (see PCT Article 11 and MPEP 1810), a Notification of the International Application Number and of the International Filing Date (Form PCT/RO/105) will be issued in due course, subject to prescriptions concerning national security, and the date shown on this Acknowledgement Receipt will establish the international filing date of the application.



UNITED STATES PATENT AND TRADEMARK OFFICE

UNITED STATES DEPARTMENT OF COMMERCE
United States Patent and Trademark Office
Address: COMMISSIONER FOR PATENTS
P.O. Box 1450
Alexandria, Virginia 22313-1450
www.uspto.gov

APPLICATION NO.	FILING DATE	FIRST NAMED INVENTOR	ATTORNEY DOCKET NO.	CONFIRMATION NO.
90/012,439	08/17/2012	5796183	5796183RX	4155

22045 7590 09/20/2012
BROOKS KUSHMAN P.C.
1000 TOWN CENTER
TWENTY-SECOND FLOOR
SOUTHFIELD, MI 48075

EXAMINER

NGUYEN, LINH M

ART UNIT	PAPER NUMBER
3992	

MAIL DATE	DELIVERY MODE
09/20/2012	PAPER

Please find below and/or attached an Office communication concerning this application or proceeding.

The time period for reply, if any, is set in the attached communication.

Order Granting / Denying Request For Ex Parte Reexamination	Control No.	Patent Under Reexamination
	90/012,439	5796183
	Examiner	Art Unit
	LINH M. NGUYEN	3992

--The MAILING DATE of this communication appears on the cover sheet with the correspondence address--

The request for *ex parte* reexamination filed 17 August 2012 has been considered and a determination has been made. An identification of the claims, the references relied upon, and the rationale supporting the determination are attached.

Attachments: a) PTO-892, b) PTO/SB/08, c) Other: _____

1. The request for *ex parte* reexamination is GRANTED.

RESPONSE TIMES ARE SET AS FOLLOWS:

For Patent Owner's Statement (Optional): TWO MONTHS from the mailing date of this communication (37 CFR 1.530 (b)). **EXTENSIONS OF TIME ARE GOVERNED BY 37 CFR 1.550(c).**

For Requester's Reply (optional): TWO MONTHS from the **date of service** of any timely filed Patent Owner's Statement (37 CFR 1.535). **NO EXTENSION OF THIS TIME PERIOD IS PERMITTED.** If Patent Owner does not file a timely statement under 37 CFR 1.530(b), then no reply by requester is permitted.

2. The request for *ex parte* reexamination is DENIED.

This decision is not appealable (35 U.S.C. 303(c)). Requester may seek review by petition to the Commissioner under 37 CFR 1.181 within ONE MONTH from the mailing date of this communication (37 CFR 1.515(c)). **EXTENSION OF TIME TO FILE SUCH A PETITION UNDER 37 CFR 1.181 ARE AVAILABLE ONLY BY PETITION TO SUSPEND OR WAIVE THE REGULATIONS UNDER 37 CFR 1.183.**

In due course, a refund under 37 CFR 1.26 (c) will be made to requester:

- a) by Treasury check or,
- b) by credit to Deposit Account No. _____, or
- c) by credit to a credit card account, unless otherwise notified (35 U.S.C. 303(c)).

--	--	--

cc:Requester (if third party requester)

DECISION

A substantial new question (SNQ) of patentability affecting claims 18 and 27 of United States Patent Number 5,796,183 (“the base patent” or “the 183’ patent”) is raised by the request for *ex parte* reexamination.

Information Disclosure Statement

The Information Disclosure Statement submission of August 17, 2012 has been considered. It is to be noted, however, that where patents, publications, and other such items of information are submitted by a patent owner in compliance with the requirements of the rules, **the requisite degree of consideration to be given to such information will be limited by the degree to which the patent owner has explained the content and relevance of the information.** In instances where no explanation of citations (items of information) is required and none is provided for an information citation, only a cursory review of that information is required. The examiner need only perform a cursory evaluation of each unexplained item of information, to the extent that he/she needs in order to determine whether he/she will evaluate the item further. If the cursory evaluation reveals the item not to be useful, the examiner may simply stop looking at it. This review may often take the form of considering the documents in the same manner as other documents in Office search files are considered by the examiner while conducting a search of the prior art in a proper field of search. **The initials of the examiner, in this proceeding, placed adjacent to the citations on the PTO-1449 or PTO/SB/08A and 08B or its equivalent, without an indication in the record to the contrary in the record, do not**

Art Unit: 3992

signify that the information has been considered by the examiner any further than to the extent noted above. See MPEP 609, seventh paragraph, Revision 5, Aug. 2006 [page 600-141].

References

Boie et al., U.S. Patent No. 5,463,388, filed on January 29, 1993 and issued on October 31, 1996 ("Boie '388").

Prosecution History

The base patent stems from United States Patent Application No. 08/601,268 (hereinafter "the base application").

The examiner generally agrees with the description of the prosecution history found in the Request at pp. 5-7, and that discussion is incorporated by reference. The base application was ultimately allowed without a statement of reasons for allowance. From the prosecution history, it appears likely that claims 18 and 27 were allowed in the base application because of the amendatory language in claim 18 and the new independent claim 27, as discussed at page 6-7 of the Request.

Proposed Rejections

Under 35 U.S.C. 102(a)

Claims 18 and 27 of the '183 patent are unpatentable under 35 U.S.C. § 102(a) as being anticipated by Boie '388.

Analysis of the Prior Art Provided in the Request

35 U.S.C. 102(a)

Boie '388:

It is **agreed** that Boie '388 raises SNQ for claims 18 and 27 of the '183 patent. Insofar as the explanation at pages 8-12 of the Request and the item-matching at page 12-17 of Claim Chart of the Request at least facially suggest that Boie '388 teaches a substantial number of claimed features. A reasonable examiner would consider that Boie '388 important in deciding whether or not claims 18 and 27 of the '183 patent are patentable. Accordingly, Boie '388 raises a substantial new question of patentability as to claims 18 and 27, which question has not been decided in a previous examination of the '306 patent.

Such teachings are not cumulative to any written discussion on the record of the teachings of the prior art, were not previously considered nor addressed during a prior examination and the same question of patentability was not the subject of a final holding of invalidity by Federal Courts.

Art Unit: 3992

Correspondence

All correspondence relating to this *ex parte* reexamination proceeding should be directed:

By Mail to: Mail Stop *Ex Parte* Reexam
Central Reexamination Unit
Commissioner for Patents
United States Patent & Trademark Office
P.O. Box 1450
Alexandria, VA 22313-1450

By FAX to: (571) 273-9900
Central Reexamination Unit

By hand: Customer Service Window
Randolph Building
401 Dulany Street
Alexandria, VA 22314

Registered users of EFS-Web may alternatively submit such correspondence via the electronic filing system EFS-Web, at <https://efs.uspto.gov/efile/myportal/efs-registered>. EFS-Web offers the benefit of quick submission to the particular area of the Office that needs to act on the correspondence. Also, EFS-Web submissions are "soft scanned" (i.e., electronically uploaded) directly into the official file for the reexamination proceeding, which offers parties the opportunity to review the content of their submissions after the "soft scanning" process is complete.

Any inquiry concerning this communication should be directed to Linh M. Nguyen at telephone number 571-272-1749.

Signed:

/Linh M. Nguyen/
Primary Examiner
Central Reexamination Unit 3992

Conferees:

/Margaret Rubin/

Primary Examiner CRU 3992



MARK J. REINHART
Supervisory Patent Reexamination Specialist
CRU -- Art Unit 3992

Doc Code: IDS

Received: 08/27/2012

90/012,439

Document Description: Information Disclosure Statement filed

PTO/SB/42 (07-09)

Approved for use through 07/31/2012. OMB 0651-0031

U.S. Patent and Trademark Office; U. S. DEPARTMENT OF COMMERCE

Under the Paperwork Reduction Act of 1995, no persons are required to respond to a collection of information unless it displays a valid OMB control number.

37 CFR 1.501 INFORMATION DISCLOSURE CITATION IN A PATENT (Sheet <u>1</u> of <u>1</u>)				Docket Number (Optional) 5796183RX		Patent Number 5,796,183	
				Applicant Hourmand			
				Issue Date August 18, 1998		Art Unit 2836 3992	
U.S. PATENT DOCUMENTS							
EXAMINER INITIAL	DOCUMENT NUMBER	DATE	NAME	CLASS	SUBCLASS	FILING DATE IF APPROPRIATE	
	4,766,368	8-23-1988	Cox			9-30-1986	
	4,806,709	2-21-1989	Evans			5-26-1987	
	4,893,071	1-09-1990	Miller			5-24-1988	
	5,113,041	5-12-1992	Blonder et al.			12-28-1990	
	5,337,353	8-09-1994	Boie et al.			4-01-1992	
	5,463,388	10-31-1995	Boie et al.			1-29-1993	
FOREIGN PATENT DOCUMENTS							
	DOCUMENT NUMBER	DATE	COUNTRY	CLASS	SUBCLASS	TRANSLATION	
						YES	NO
OTHER DOCUMENTS (Including Author, Title, Date, Pertinent Pages, Etc.)							
EXAMINER	/Linh Nguyen/			DATE CONSIDERED	09/12/2012		

This collection of information is required by 37 CFR 1.501. The information is required to obtain or retain a benefit by the public which is to file (and by the USPTO to process) an application. Confidentiality is governed by 35 U.S.C. 122 and 37 CFR 1.14. This collection is estimated to take 2 hours to complete, including gathering, preparing, and submitting the completed application form to the USPTO. Time will vary depending upon the individual case. Any comments on the amount of time you require to complete this form and/or suggestions for reducing this burden, should be sent to the Chief Information Officer, U.S. Patent and Trademark Office, U.S. Department of Commerce, P.O. Box 1450, Alexandria, VA 22313-1450. DO NOT SEND FEES OR COMPLETED FORMS TO THIS ADDRESS. SEND TO: Commissioner for Patents, P.O. Box 1450, Alexandria, VA 22313-1450.

If you need assistance in completing the form, call 1-800-PTO-9199 and select option 2.

ALL REFERENCES CONSIDERED EXCEPT WHERE LINED THROUGH. /L.N./

Reexamination 	Application/Control No. 90/012,439	Applicant(s)/Patent Under Reexamination 5796183
	Certificate Date	Certificate Number

Requester Correspondence Address: <input checked="" type="checkbox"/> Patent Owner <input type="checkbox"/> Third Party
BROOKS KUSHMAN P.C. 1000 TOWN CENTER TWENTY-SECOND FLOOR SOUTHFIELD, MI 48075

LITIGATION REVIEW <input checked="" type="checkbox"/>	LMN <small>(examiner initials)</small>	9/12/12 <small>(date)</small>
Case Name		Director Initials
U.S. District - Michigan Western (Grand Rapids) 1:10cv691 (CLOSED) Nartron Corporation et al v. Hourmand		ML for Iy
U.S. District- Pennsylvania Middle (Harrisburg) 1:06cv1777 Qrg, Ltd, A/K/A Quantum Research Group, Ltd v. Nartron Corporat (CLOSED)		↓
U.S. District - Pennsylvania Western (Pittsburgh) 2:06cv500 Qrg, Ltd v. Nartron Corporation (CLOSED)		

COPENDING OFFICE PROCEEDINGS	
TYPE OF PROCEEDING	NUMBER
1. N/A	
2.	
3.	
4.	

Search Notes



Application/Control No.

90/012,439

Examiner

LINH M. NGUYEN

Applicant(s)/Patent under Reexamination

5796183

Art Unit

3992

SEARCHED

Class	Subclass	Date	Examiner
None		9/12/2012	LMN

INTERFERENCE SEARCHED

Class	Subclass	Date	Examiner

**SEARCH NOTES
(INCLUDING SEARCH STRATEGY)**

	DATE	EXMR
Review of patented file's prosecution history	9/12/2012	LMN



UNITED STATES PATENT AND TRADEMARK OFFICE

UNITED STATES DEPARTMENT OF COMMERCE
United States Patent and Trademark Office
Address: COMMISSIONER FOR PATENTS
P.O. Box 1450
Alexandria, Virginia 22313-1450
www.uspto.gov

APPLICATION NO.	FILING DATE	FIRST NAMED INVENTOR	ATTORNEY DOCKET NO.	CONFIRMATION NO.
90/012,439	08/17/2012	5796183	5796183RX	4155

22045 7590 09/19/2012
BROOKS KUSHMAN P.C.
1000 TOWN CENTER
TWENTY-SECOND FLOOR
SOUTHFIELD, MI 48075

EXAMINER

NGUYEN, LINH M

ART UNIT PAPER NUMBER

3992

MAIL DATE DELIVERY MODE

09/19/2012

PAPER

Please find below and/or attached an Office communication concerning this application or proceeding.

The time period for reply, if any, is set in the attached communication.

Ex Parte Reexamination Interview Summary – Pilot Program for Waiver of Patent Owner's Statement	Control No.	Patent For Which Reexamination is Requested
	90/012,439	5,796,183
	Examiner	Art Unit

-- The MAILING DATE of this communication appears on the cover sheet with the correspondence address. --

All participants (USPTO official and patent owner):

- (1) Alicia Kelley-Collier CRU Paralegal (3)
- (2) BROOKS KUSHMAN P.C. (Christine) Will Call back (4)

Date of Telephonic Interview: September 7, 2012.

The USPTO official requested waiver of the patent owner's statement pursuant to the pilot program for waiver of patent owner's statement in *ex parte* reexamination proceedings.*

- The patent owner **agreed** to waive its right to file a patent owner's statement under 35 U.S.C. 304 in the event reexamination is ordered for the above-identified patent.
- The patent owner **did not agree** to waive its right to file a patent owner's statement under 35 U.S.C. 304 at this time.

The patent owner is not required to file a written statement of this telephone communication under 37 CFR 1.560(b) or otherwise. However, any disagreement as to this interview summary must be brought to the immediate attention of the USPTO; and no later than one month from the mailing date of this interview summary. Extensions of time are governed by 37 CFR 1.550(c).

*For more information regarding this pilot program, see *Pilot Program for Waiver of Patent Owner's Statement in Ex Parte Reexamination Proceedings*, 75 Fed. Reg. 47269 (August 5, 2010), available on the USPTO Web site at <http://www.uspto.gov/patents/law/notices/2010.jsp>.

- USPTO personnel were unable to reach the patent owner.

The patent owner may contact the USPTO personnel at the telephone number provided below if the patent owner decides to waive the right to file a patent owner's statement under 35 U.S.C. 304.

/A. Kelley-Collier/ (571) 272-6059
Signature and telephone number of the USPTO official who contacted or attempted to contact the patent owner.

cc: Requester (if third party requester)

Litigation Search Report CRU 3999

Reexam Control No. 90/012,439

To: Examiner
Location: CRU
Art Unit: 3999
Date: 8/30/12
Case Serial Number: 90/012,439

From: Alicia Kelley-Collier
Location: CRU 3999
MDE 5A74
Phone: (571) 272-6059
alicia.kelley@uspto.gov

Search Notes

U.S. Patent No. 5,796,183

- 1) I performed a KeyCite Search in Westlaw, which retrieves all history on the patent including any litigation.
- 2) I performed a search on the patent in Lexis CourtLink for any open dockets or closed cases.
- 3) I performed a search in Lexis in the Federal Courts and Administrative Materials databases for any cases found.
- 4) I performed a search in Lexis in the IP Journal and Periodicals database for any articles on the patent.
- 5) I performed a search in Lexis in the news databases for any articles about the patent or any articles about litigation on this patent.

Litigation involving this patent was found.

1:10cv691 Closed
1:06cv1777 Closed
2:06cv500 Closed
2:03cv75169 Closed

Westlaw Delivery Summary Report for KELLEY-COLLIER,A

Date/Time of Request:	Thursday, August 30, 2012 11:22 Central
Client Identifier:	5796183
Database:	KEYCITE-HIST
Citation Text:	US PAT 5796183
Service:	KeyCite
Lines:	313
Documents:	1
Images:	0

The material accompanying this summary is subject to copyright. Usage is governed by contract with Thomson Reuters, West and their affiliates.

KEYCITE

**C US PAT 5796183 CAPACITIVE RESPONSIVE ELECTRONIC SWITCHING CIRCUIT, Assignee:
Nartron Corporation (Aug 18, 1998)**

History**Direct History**

=> 1 **CAPACITIVE RESPONSIVE ELECTRONIC SWITCHING CIRCUIT**, US PAT 5796183,
1998 WL 1463338 (U.S. PTO Utility Aug 18, 1998)

Patent Family

2 CAPACITIVE REACTION ELECTRONIC SWITCH FOR ZERO FORCE APPLICATION
CONTAINS OSCILLATOR SUPPLYING FREQUENCY OF 50 KHZ OR HIGHER, AND IN-
PUT TOUCH TERMINAL, Derwent World Patents Legal 1997-394976

Assignments

3 Action: ASSIGNMENT OF ASSIGNORS INTEREST (SEE DOCUMENT FOR DETAILS).
Number of Pages: 002, (DATE RECORDED: Aug 17, 2012)
4 Action: ASSIGNMENT OF ASSIGNORS INTEREST (SEE DOCUMENT FOR DETAILS).
Number of Pages: 002, (DATE RECORDED: Aug 17, 2012)
5 Action: ASSIGNMENT OF ASSIGNORS INTEREST (SEE DOCUMENT FOR DETAILS).
Number of Pages: 011, (DATE RECORDED: Dec 22, 2009)
6 ASSIGNEE(S): NARTRON CORPORATION, (DATE RECORDED: Feb 04, 1997)
7 Assignee(s): NARTRON CORPORATION, (DATE RECORDED: Jan 31, 1996)

Patent Status Files

.. Certificate of Correction, (OG DATE: Nov 01, 2011)
.. Certificate of Correction, (OG DATE: May 11, 1999)

Docket Summaries

10 NARTRON CORPORATION ET AL v. HOURMAND, (W.D.MICH. Jul 20, 2010) (NO.
1:10CV00691), (28 USC 1338 PATENT INFRINGEMENT)
11 "QRG, LTD. v. NARTRON CORPORATION", (M.D.PA. Sep 12, 2006) (NO. 1:06CV01777),
(28 USC 2201 DECLARATORY JUDGEMENT)
12 "NARTRON CORP v. GEN ELEC, ET AL", (E.D.MICH. Dec 24, 2003) (NO. 2:03CV75169)

Litigation Alert

- 13 Derwent LitAlert P2010-30-63 (Jul 20, 2010) Action Taken: complaint for PATENT INFRINGEMENT
- 14 Derwent LitAlert P2007-35-68 (Sep 12, 2006) Action Taken: A complaint was filed
- 15 Derwent LitAlert P2007-02-10 (Apr 13, 2006) Action Taken: Order of court - Ordered that motion to dismiss by defendant is denied. Further ordered that the case is to be transferred to the US District Court for the Middle Dist of Pennsylvania

Prior Art (Coverage Begins 1976)

- C** 16 CAPACITIVE PRESS CONTROL ACTUATION SYSTEM, US PAT 5235217 Assignee: ISB Ltd., (U.S. PTO Utility 1993)
- C** 17 CAPACITIVE SENSOR CONTROL SYSTEM, US PAT 4323829 Assignee: Fish, Barry M., (U.S. PTO Utility 1982)
- C** 18 CAPACITY RESPONSIVE CONTROL CIRCUIT, US PAT 4831279 Assignee: Nartron Corporation, (U.S. PTO Utility 1989)
- C** 19 CAPACITY RESPONSIVE KEYBOARD, US PAT 5087825 Assignee: Nartron Corporation, (U.S. PTO Utility 1992)
- C** 20 CHARGE SENSITIVE SWITCH, US PAT 4159473 Assignee: Johnson-Lazare Canada Limited, (U.S. PTO Utility 1979)
- C** 21 CONTROL-SAFE CAPACITIVE SWITCH, US PAT 5233231 Assignee: Pepperl & plus; Fuchs, Inc., (U.S. PTO Utility 1993)
- C** 22 DC TOUCH CONTROL SWITCH CIRCUIT, US PAT 4758735 Assignee: Nartron Corporation, (U.S. PTO Utility 1988)
- C** 23 DISCRIMINATING CONTACT SENSOR, US PAT 3911215 Assignee: ELOGRAPHICS, INC., (U.S. PTO Utility 1975)
- C** 24 DISPLAY DEVICE HAVING UNPATTERNED TOUCH DETECTION, US PAT 4476463 Assignee: Interaction Systems, Inc., (U.S. PTO Utility 1984)
- C** 25 ELECTROGRAPHIC SENSOR FOR DETERMINING PLANAR COORDINATES, US PAT 3798370 Assignee: ELOGRAPHICS, INC., (U.S. PTO Utility 1974)
- C** 26 ELECTRONIC SWITCH ARRANGEMENTS, US PAT 3651391 Assignee: BLACK & DECKER INC., (U.S. PTO Utility 1972)
- C** 27 ELECTRONIC WATCH WITH TOUCH-SENSITIVE KEYS, US PAT 4257117 Assignee: Ebauches S.A., (U.S. PTO Utility 1981)
- C** 28 ELECTRONICALLY ACTUATED ELECTRIC SWITCH, US PAT 4213061 (U.S. PTO Utility 1980)
- C** 29 HAND SANITIZING STATION, US PAT 4942631 Assignee: Barry Robertson; Rosa, Rudy, (U.S. PTO Utility 1990)
- C** 30 INDUCTION COOK-TOP WITH IMPROVED TOUCH CONTROL, US PAT 4308443 Assignee: Rangaire Corporation, (U.S. PTO Utility 1981)
- C** 31 KEYBOARD SWITCH, US PAT 4503294 Assignee: Nippon Mektron Ltd., (U.S. PTO Utility 1985)
- C** 32 LAMP RESPONSIVE TO THE HUMAN TOUCH UPON A LIVING PLANT AND CONTROL

- SYSTEM THEREFOR, US PAT 4152629 (U.S. PTO Utility 1979)
- C** 33 LUCENT ELECTROGRAPHIC SENSOR FOR DETERMINING PLANAR COORDINATES, US PAT 4071689 Assignee: Elographics, Incorporated, (U.S. PTO Utility 1978)
 - C** 34 MULTI-WAY SWITCH SYSTEM HAVING PLURAL REMOTE TOUCH PADS, US PAT 5066898 Assignee: Delat Systems, Incorporated, (U.S. PTO Utility 1991)
 - C** 35 NONPLANAR TRANSPARENT ELECTROGRAPHIC SENSOR, US PAT 4220815 Assignee: Elographics, Inc., (U.S. PTO Utility 1980)
 - C** 36 PERSONAL-CARE APPARATUS COMPRISING A CAPACITIVE ON/OFF SWITCH, US PAT 5453644 Assignee: U.S. Philips Corporation, (U.S. PTO Utility 1995)
 - C** 37 PROXIMITY ACTUATED POWER CONTROL VARIABLE AS TO SENSE AND MAGNITUDE, US PAT 3984757 (U.S. PTO Utility 1976)
 - C** 38 PROXIMITY CONTROLLED POWER SWITCHING CIRCUIT, US PAT 4246533 (U.S. PTO Utility 1981)
 - C** 39 PROXIMITY PAD WITH CONTROLLED ILLUMINATION, US PAT 4016453 (U.S. PTO Utility 1977)
 - C** 40 PROXIMITY SWITCHING SYSTEM, US PAT 4031408 (U.S. PTO Utility 1977)
 - C** 41 SELF TIMING SWITCH, US PAT 3965465 (U.S. PTO Utility 1976)
 - C** 42 SINGLE-ELECTRODE CAPACITANCE TOUCHPAD SENSOR SYSTEMS, US PAT 4237421 Assignee: General Electric Company, (U.S. PTO Utility 1980)
 - C** 43 TOUCH ACTIVATED AC, FULL WAVE, TWO WIRE SWITCHES, US PAT 3549909 Assignee: HALL?BARKAN INSTRUMENTS, INC., (U.S. PTO Utility 1970)
 - H** 44 TOUCH-CONTROL ADAPTER FOR ELECTRIC LAMPS, US PAT 4211959 Assignee: Westek Corporation, (U.S. PTO Utility 1980)
 - C** 45 TOUCH CONTROL FOR ELECTRICAL APPARATUS, US PAT 3641410 Assignee: BLACK & DECKER INC., (U.S. PTO Utility 1972)
 - C** 46 TOUCH CONTROL SWITCH, US PAT 4289972 (U.S. PTO Utility 1981)
 - C** 47 TOUCH CONTROL SWITCH, US PAT 4264831 (U.S. PTO Utility 1981)
 - C** 48 TOUCH CONTROL SWITCH, US PAT 4210822 (U.S. PTO Utility 1980)
 - C** 49 TOUCH CONTROL SWITCH CIRCUIT, US PAT 4731548 Assignee: Nartron Corporation, (U.S. PTO Utility 1988)
 - C** 50 TOUCH CONTROL SYSTEM, US PAT 5572205 Assignee: Donnelly Technology, Inc., (U.S. PTO Utility 1996)
 - C** 51 TOUCH CONTROLLED DISPLAY DEVICE, US PAT 4910504 Assignee: Touch Display Systems AB, (U.S. PTO Utility 1990)
 - C** 52 TOUCH CONTROLLED ELECTRIC LIGHT SOCKET WITH HIGH CURRENT TOLERANCE, US PAT 5208516 (U.S. PTO Utility 1993)
 - C** 53 TOUCH LAMP, LATCHING AC SOLID STATE TOUCH SWITCH USABLE WITH SUCH LAMP, AND CIRCUITS FOR THE SAME, US PAT 3899713 Assignee: HALL?BARKAN INSTRUMENTS, INC., (U.S. PTO Utility 1975)
 - C** 54 TOUCH OVERLAY FOR IMPROVED TOUCH SENSITIVITY, US PAT 5386219 Assignee: In-

- ternational Business Machines Corp., (U.S. PTO Utility 1995)
- C** 55 TOUCH RESPONSIVE POWER CONTROL SYSTEM, US PAT 4939382 (U.S. PTO Utility 1990)
 - C** 56 TOUCH-RESPONSIVE SOCKET, US PAT 4101805 Assignee: Destron, Inc., (U.S. PTO Utility 1978)
 - C** 57 TOUCH SENSITIVE CONTROL PANEL, US PAT 5012124 (U.S. PTO Utility 1991)
 - C** 58 TOUCH SENSITIVE ELECTRIC SWITCH, US PAT 4289980 (U.S. PTO Utility 1981)
 - C** 59 TOUCH SENSITIVE ELECTRONIC SWITCH, US PAT 3879618 Assignee: MAGIC DOT, INC., (U.S. PTO Utility 1975)
 - C** 60 TOUCH SENSITIVE POWER CONTROL CIRCUIT, US PAT 3666988 Assignee: ROBERT E BELLIS, (U.S. PTO Utility 1972)
 - C** 61 TOUCH SENSITIVE POWER CONTROL SYSTEM, US PAT 3919596 Assignee: BELLIS ROBERT ELLIOTT, (U.S. PTO Utility 1975)
 - C** 62 TOUCH SENSITIVE SWITCH, US PAT 4360737 Assignee: Leviton Manufacturing Co., Inc., (U.S. PTO Utility 1982)
 - C** 63 TOUCH SWITCH CIRCUITS, US PAT 4119864 Assignee: RCA Corporation, (U.S. PTO Utility 1978)
 - C** 64 TOUCH SWITCH DEVICE, US PAT 4352141 Assignee: Starcote Limited, (U.S. PTO Utility 1982)
 - C** 65 TOUCH TERMINAL WITH RELIABLE PAD SELECTION, US PAT 4374381 Assignee: Interaction Systems, Inc., (U.S. PTO Utility 1983)

US District Court Civil Docket

U.S. District - Michigan Western
(Grand Rapids)

1:10cv691

Nartron Corporation et al v. Hourmand

This case was retrieved from the court on Friday, October 29, 2010

Date Filed: 07/20/2010	Class Code: CLOSED
Assigned To: Judge Robert Holmes Bell	Closed: Yes
Referred To:	Statute: 28:1338
Nature of suit: Patent (830)	Jury Demand: None
Cause: Patent Infringement	Demand Amount: \$0
Lead Docket: None	NOS Description: Patent
Other Docket: None	
Jurisdiction: Federal Question	

Litigants

Attorneys

Nartron Corporation
Plaintiff

Robert CJ Tuttle
[COR LD NTC]
Brooks Kushman PC
1000 Town Ctr, 22ND FL
Southfield , MI 48075-1238
USA
(248) 358-4400
Fax: (248) 358-3351
Email: RTUTTLE@BROOKSKUSHMAN.COM

Uusi, Llc
Plaintiff

Robert CJ Tuttle
[COR LD NTC]
Brooks Kushman PC
1000 Town Ctr, 22ND FL
Southfield , MI 48075-1238
USA
(248) 358-4400
Fax: (248) 358-3351
Email: RTUTTLE@BROOKSKUSHMAN.COM

Byron Hourmand
Defendant

Date	#	Proceeding Text	Source
07/20/2010	1	COMPLAINT against Byron Hourmand filed by Nartron Corporation, UUSI, LLC (Attachments: # 1 Exhibit A, # 2 Exhibit B, # 3 Exhibit C, # 4 Exhibit D, # 5 Exhibit E, # 6 Exhibit F, # 7 Exhibit G, # 8 Exhibit H, # 9 Exhibit I, # 10 Exhibit J, # 11 Exhibit K, # 12 Civil Cover Sheet)(rmw) (Entered: 07/21/2010)	
07/20/2010	--	RECEIPT: in the amount of \$350.00, receipt number GR020949; for filing fees (rmw) (Entered: 07/21/2010)	
07/20/2010	--	SUMMONS ISSUED as to defendant Byron Hourmand (rmw) (Entered: 07/21/2010)	
07/20/2010	2	CORPORATE DISCLOSURE STATEMENT by Nartron Corporation (rmw) (Entered: 07/21/2010)	
07/20/2010	3	CORPORATE DISCLOSURE STATEMENT by UUSI, LLC (rmw) (Entered: 07/21/2010)	

Thursday, August 30, 2012

- 07/21/2010 4 REPORT from the Clerk, WDMI, to the Director of the U.S. Patent and Trademark Office on the filing of a PATENT ACTION (rmw) (Entered: 07/21/2010)
- 08/16/2010 5 SUMMONS returned executed; Byron Hourmand served on 8/4/2010, answer due 8/25/2010 (Brandenburg, Robert) (Entered: 08/16/2010)
- 08/16/2010 6 SUMMONS returned executed; Byron Hourmand served on 7/27/2010, answer due 8/25/2010 (Brandenburg, Robert) (Entered: 08/16/2010)
- 09/01/2010 7 UNOPPOSED MOTION to approve consent judgment by plaintiffs Nartron Corporation, UUSI, LLC; (Tuttle, Robert) (Entered: 09/01/2010)
- 09/08/2010 8 ORDER granting 7 motion to approve consent judgment ; signed by Judge Robert Holmes Bell (Judge Robert Holmes Bell, kcb) (Entered: 09/08/2010)
- 09/09/2010 9 REPORT from the Clerk, WDMI, to the Director of the U.S. Patent and Trademark Office on the determination of a PATENT ACTION (gjf) (Entered: 09/09/2010)

Copyright © 2012 LexisNexis CourtLink, Inc. All rights reserved.
*** THIS DATA IS FOR INFORMATIONAL PURPOSES ONLY ***

US District Court Civil Docket

**U.S. District - Pennsylvania Middle
(Harrisburg)**

1:06cv1777

Qrg, Ltd, A/K/A Quantum Research Group, Ltd v. Nartron Corporatio

This case was retrieved from the court on Wednesday, May 07, 2008

Date Filed: 09/12/2006	Class Code: CLOSED
Assigned To: Honorable Sylvia H Rambo	Closed: Yes
Referred To:	Statute: 28:2201
Nature of suit: Patent (830)	Jury Demand: Both
Cause: Declaratory Judgement	Demand Amount: \$0
Lead Docket: None	NOS Description: Patent
Other Docket: U.S. District Court, Western District of PA, 2:06-CV-500	
Jurisdiction: Federal Question	

Litigants

Attorneys

Qrg, Ltd A/K/A Quantum Research Group, Ltd
Plaintiff

Andrew E Falsetti
[COR LD NTC]
[Term: 10/23/2007]
Reed Smith LLP
435 Sixth Avenue
Pittsburgh , PA 15219
USA
412-288-3844
Email: Afalsetti@reedsmith.com

Clay P. Hughes
[COR LD NTC]
Reed Smith
435 Sixth Avenue
Pittsburgh , PA 15219
USA
412.288.3008
Email: CHUGHES@REEDSMITH.COM

Gene A Tabachnick
[COR LD NTC]
Reed Smith LLP
435 Sixth Avenue
Pittsburgh , PA 15219
USA
412-288-3258
Email: Gtabachnick@reedsmith.com

Robert B Hoffman
[COR LD NTC]
Wolf Block
213 Market Street, 9TH Floor
Harrisburg , PA 17101
USA
(717) 237-7182
Email: Rhoffman@wolfblock.com

Thursday, August 30, 2012

Nartron Corporation
Defendant

Mark D Chuey
[COR LD NTC]
Brooks Kushman PC
1000 Town Center
22ND Floor
Southfield , MI 48075-1238
USA
248-358-4400
Email: Mchuey@brookskushman.com

Mark A Grace
[COR LD NTC]
Cohen & Grigsby PC
11 Stanwix Street
15TH Floor
Pittsburgh , PA 15222-1319
USA
412-297-4900
Email: Mgrace@cohenlaw.com

Robert CJ Tuttle
[COR LD NTC]
Brooks Kushman PC
1000 Town Center
22ND Floor
Southfield , MI 48075-1238
USA
248-358-4400
Email: Rtuttle@brookskushman.com

Thomas C Wettach
[COR LD NTC]
Cohen & Grigsby, PC
11 Stanwix Street
15TH Floor
Pittsburgh , PA 15222
USA
412-297-4900
Email: Twettach@cohenlaw.com

Jill L Bradley
[COR LD NTC]
Cohen & Grigsby, PC
11 Stanwix Street, 15TH Floor
Pittsburgh , PA 15222
USA
412-297-4707
Email: Jbradley@cohenlaw.com

Nartron Corporation Counterclaim
Plaintiff

Mark D Chuey
[COR LD NTC]
Brooks Kushman PC
1000 Town Center
22ND Floor
Southfield , MI 48075-1238
USA
248-358-4400
Email: Mchuey@brookskushman.com

Mark A Grace
[COR LD NTC]
Cohen & Grigsby PC
11 Stanwix Street
15TH Floor
Pittsburgh , PA 15222-1319
USA
412-297-4900
Email: Mgrace@cohenlaw.com

Robert CJ Tuttle

Thursday, August 30, 2012

[COR LD NTC]
Brooks Kushman PC
1000 Town Center
22ND Floor
Southfield , MI 48075-1238
USA
248-358-4400
Email: Rtuttle@brookskushman.com

Thomas C Wettach
[COR LD NTC]
Cohen & Grigsby, PC
11 Stanwix Street
15TH Floor
Pittsburgh , PA 15222
USA
412-297-4900
Email: Twettach@cohenlaw.com

Jill L Bradley
[COR LD NTC]
Cohen & Grigsby, PC
11 Stanwix Street, 15TH Floor
Pittsburgh , PA 15222
USA
412-297-4707
Email: Jbradley@cohenlaw.com

Qrg, Ltd Counterclaim
Defendant

Andrew E Falsetti
[COR LD NTC]
[Term: 10/23/2007]
Reed Smith LLP
435 Sixth Avenue
Pittsburgh , PA 15219
USA
412-288-3844
Email: Afalsetti@reedsmith.com

Clay P Hughes
[COR LD NTC]
Reed Smith
435 Sixth Avenue
Pittsburgh , PA 15219
USA
412.288.3008
Email: CHUGHES@REEDSMITH.COM

Gene A Tabachnick
[COR LD NTC]
Reed Smith LLP
435 Sixth Avenue
Pittsburgh , PA 15219
USA
412-288-3258
Email: Gtabachnick@reedsmith.com

Robert B Hoffman
[COR LD NTC]
Wolf Block Schorr and Solis-Cohen, LLP
213 Market Street, 9TH Floor
Harrisburg , PA 17101
USA
(717) 237-7182
Email: Rhoffman@wolfblock.com

Date	#	Proceeding Text	Source
09/12/2006	1	Case transferred in from District of Western District of Pennsylvania; Case Number 2:06-CV-500. Original file with documents numbered 1-17, certified copy of transfer order and docket sheet	

Thursday, August 30, 2012

received., filed by QRG, LTD.. (Attachments: # 1 Civil Cover Sheet # 2 Receipt# 3 Doc. 2- Disclosure Statement# 4 Doc. 3- Summons# 5 Doc. 4- Motion to Dismiss# 6 Proposed Order to Motion to Dismiss# 7 Doc. 5- Brief in Support to Motion to Dismiss# 8 Exhibit A# 9 Exhibit B# 10 Exhibit C# 11 Doc. 6- Notice of Appearance by Thomas C. Wettach# 12 Doc. 7- Notice; Response to Motion to Dismiss# 13 Doc. 8- Motion for Discovery# 14 Proposed Order for Motion for Discovery# 15 Exhibit 1# 16 Exhibit 2# 17 Exhibit 3# 18 Exhibit 4# 19 Exhibit 6# 20 Exhibit 7# 21 Exhibit 8# 22 Exhibit 9# 23 Exhibit 5 (Motion for Discovery)# 24 Doc. 9- Notice:Response to Motion for Discovery# 25 Doc. 10- Brief in Opp. to Motion for Discovery# 26 Exhibit A (Brief in Opp. to Discovery)# 27 Exhibit B (Brief in Opp. to Discovery)# 28 Exhibit C (Brief in Opp. for Discovery)# 29 Exhibit D- (Brief in Opp. to Discovery)# 30 Doc. 11- Order Granting Motion for Discovery# 31 Doc. 12- Brief in Opp. to Motion to Dismiss# 32 Exhibit A (Brief in Opp. to Motion to Dismiss)# 33 Exhibit B (Brief in Opp. to Motion to Dismiss)# 34 Exhibit C (Brief in Opp. to Motion to Dismiss)# 35 Declaration of Richard T. Ting# 36 Declaration of Andrew E. Falsetti# 37 Declaration of Harald Philipp# 38 Declaration of Chris Bede# 39 Doc. 3 - Motion for Leave to File a Brief in Reply# 40 Exhibit A (Motion to File Brief in Reply)# 41 Doc. 14- Response to Motion for Leave to File a Brief in Reply# 42 Supplemental Declaration of Richard Ting# 43 Doc. 15-Order Granting Motion to File Brief in Reply# 44 Doc. 16- Brief in Reply# 45 Exhibit A (Brief in Reply)# 46 Doc. 17- Order Denying Motion to Dismiss. ADDITIONAL ATTACHMENTS ADDED-TRANSFER LETTER AND DOCKET FROM WESTERN DISTRICT OF PA(s) added on 9/13/2006 (crh,). (Entered: 09/13/2006)

- 09/13/2006 -- SPECIAL ADMISSION FORM SENT to Andrew E. Falsetti, Mark A. Grace & Thomas C. Wettach (crh,) (Entered: 09/13/2006)
- 09/13/2006 2 Transfer Letter to Counsel (crh,) (Entered: 09/13/2006)
- 09/20/2006 3 NOTICE:A Case Mgmt Conf has been set for 10/24/2006 @ 9:15 AM before Honorable Sylvia H. Rambo. This conference is by phone and the call is to initiated by the pltf. unless otherwise agreed upon. A joint case mgmt plan is to be filed n/l/t 10/17/06.(ma,) (Entered: 09/20/2006)
- 09/21/2006 4 PETITION FOR SPECIAL ADMISSION (PRO HAC VICE) by Andrew E. Falsetti on behalf of QRG, LTD. Attorney Andrew E. Falsetti is seeking special admission. Filing Fee: 25.00 Receipt Number: 111 146455 (Attachments: # 1 Receipt) (jc) (Entered: 09/21/2006)
- 09/21/2006 5 PETITION FOR SPECIAL ADMISSION (PRO HAC VICE) by Gene A. Tabachnick on behalf of QRG, LTD. Attorney Gene A. Tabachnick is seeking special admission. Filing Fee: 25.00 Receipt Number: 111 146455 (Attachments: # 1 Receipt) (jc) (Entered: 09/21/2006)
- 09/21/2006 6 NOTICE of Appearance by Robert B. Hoffman on behalf of QRG, LTD. (Hoffman, Robert) (Entered: 09/21/2006)
- 09/22/2006 7 SPECIAL ADMISSIONS FORM APPROVED as to Andrew Falsetti, Esq. on behalf of ORG, LTD Signed by Judge Sylvia H. Rambo on 09/22/06. (ma,) (Entered: 09/22/2006)
- 09/22/2006 8 SPECIAL ADMISSIONS FORM APPROVED as to Gene Tabachnick, Esq. on behalf of QRG, LTD Signed by Judge Sylvia H. Rambo on 09/22/06. (ma,) (Entered: 09/22/2006)
- 09/29/2006 9 PETITION FOR SPECIAL ADMISSION (PRO HAC VICE) by Mark D. Chuey on behalf of NARTRON CORPORATION Attorney Mark D. Chuey is seeking special admission. Filing Fee: 25.00 Receipt Number: 111 146486 (crh,) (Entered: 09/29/2006)
- 09/29/2006 10 PETITION FOR SPECIAL ADMISSION (PRO HAC VICE) by Robert C.J. Tuttle on behalf of NARTRON CORPORATION Attorney Robert C.J. Tuttle is seeking special admission. Filing Fee: 25.00 Receipt Number: 111 146485. (crh,) (Entered: 09/29/2006)
- 10/02/2006 11 SPECIAL ADMISSIONS FORM APPROVED as to Mark D. Chuey, Esq. on behalf of Nartron/Signed by Judge Sylvia H. Rambo on 10/02/06. (ma,) (Entered: 10/02/2006)
- 10/02/2006 12 SPECIAL ADMISSIONS FORM APPROVED as to Robert Tuttle, Esq. on behalf of Nartron.Signed by Judge Sylvia H. Rambo on 10/02/06. (ma,) (Entered: 10/02/2006)
- 10/06/2006 13 ANSWER to Complaint by NARTRON CORPORATION. (Attachments: # 1 Exhibit(s) A# 2 Exhibit(s) B)(Bradley, Jill) (Entered: 10/06/2006)
- 10/17/2006 14 CASE MANAGEMENT PLAN by QRG, LTD.. (Falsetti, Andrew) (Entered: 10/17/2006)
- 10/18/2006 15 PETITION FOR SPECIAL ADMISSION (PRO HAC VICE) by Mark A. Grace on behalf of NARTRON CORPORATION Attorney Mark A. Grace is seeking special admission. Filing Fee: 25.00 Receipt Number: 111 146621. (crh,) (Entered: 10/18/2006)
- 10/18/2006 16 PETITION FOR SPECIAL ADMISSION (PRO HAC VICE) by Thomas C. Wettach on behalf of NARTRON CORPORATION Attorney Thomas C. Wettach is seeking special admission. Filing Fee: 25.00 Receipt Number: 111 146621. (crh,) (Entered: 10/18/2006)
- 10/19/2006 17 SPECIAL ADMISSIONS FORM APPROVED as to Mark Grace, Esq. on behalf of Nartron Signed by Judge Sylvia H. Rambo on 10/19/06. (ma,) (Entered: 10/19/2006)
- 10/19/2006 18 SPECIAL ADMISSIONS FORM APPROVED as to Thomas Wettach, Esq. on behalf of Nartron Signed by Judge Sylvia H. Rambo on 10/19/06. (ma,) (Entered: 10/19/2006)

10/24/2006 20 ORDER - STANDARD CASE MANAGEMENT TRACK Case placed on the 08/2007 trial list. Cases on this list are scheduled to begin on 9/4/2007 following all j/s's starting at 9:30 AM. A date certain may be discussed at the PTC which is set for 8/17/2007 @ 1:30 PM; Discovery due by 2/28/2007. Dispositive Mtns due by 6/20/2007. PTMs due by 8/10/2007. See order for other ddls. Signed by Judge Sylvia H. Rambo on 10/24/06. (ma,) (Entered: 10/24/2006)

11/01/2006 21 MOTION to Dismiss Pursuant to Fed.R.Civ.P. 12(b)(1) by NARTRON CORPORATION. (Attachments: # 1 Certificate of Compliance With Local Rule 7.1# 2 Proposed Order)(Grace, Mark) (Entered: 11/01/2006)

11/01/2006 22 BRIEF IN SUPPORT re 21 MOTION to Dismiss Pursuant to Fed.R.Civ.P. 12(b)(1) filed by NARTRON CORPORATION. (Attachments: # 1 Declaration of John E. Nemazi# 2 Exhibit(s) A - G)(Grace, Mark) (Entered: 11/01/2006)

11/16/2006 23 BRIEF IN OPPOSITION re 21 MOTION to Dismiss Pursuant to Fed.R.Civ.P. 12(b)(1) filed by QRG, LTD.. (Attachments: # 1 Affidavit /Declaration of Harald Philipp# 2 Exhibit(s) 1# 3 Exhibit(s) 2# 4 Exhibit(s) 3# 5 Exhibit(s) 4# 6 Exhibit(s) 5# 7 Exhibit(s) 6# 8 Exhibit(s) 7)(Falsetti, Andrew) (Entered: 11/16/2006)

11/27/2006 24 REPLY BRIEF re 21 MOTION to Dismiss Pursuant to Fed.R.Civ.P. 12(b)(1) filed by NARTRON CORPORATION. (Attachments: # 1 Exhibit(s) 1)(Grace, Mark) (Entered: 11/27/2006)

11/30/2006 25 MOTION to Clarify The Case Caption by QRG, LTD.. (Attachments: # 1 Certificate of Compliance with Local Rule 7.1# 2 Proposed Order)(Falsetti, Andrew) (Entered: 11/30/2006)

12/01/2006 26 BRIEF IN SUPPORT re 25 MOTION to Clarify The Case Caption filed by QRG, LTD..(Falsetti, Andrew) (Entered: 12/01/2006)

12/01/2006 27 ORDER deferring ruling on Motion to Clarify 25 pending decision on dft's mtn to dismiss Signed by Judge Sylvia H. Rambo on 12/01/06 (ma,) (Entered: 12/01/2006)

02/12/2007 29 NOTICE by QRG, LTD. of Dismissal of Related Action (Attachments: # 1 Appendix Eastern District of Michigan Order and Opinion Granting Motion to Dismiss)(Falsetti, Andrew) (Entered: 02/12/2007)

03/02/2007 30 MEMORANDUM AND ORDER: Denying in part dft's mtn to dismiss 21 as follows: a) The Court will reserve ruling with regard to the "capacitivetouch sensor products and related components" issue and grant Pltf lv to amend the complaint on or before 4/2/07. b) Mtn is denied in all other respects. 2) Pltf's Mtn to Clarify the Case Caption 25 is GRANTED. The Clrk shall change the case caption as to pltf to read: "QRG, Ltd., a/k/a Quantum Research Group, Ltd., Plaintiff." All future filings shall display this caption. 3) An amended cmo will follow. Signed by Judge Sylvia H. Rambo on 03/02/07 (ma,) (Entered: 03/02/2007)

03/02/2007 31 AMENDED CASE MANAGEMENT ORDER: J/S and Trial continued to the 10/1/2007 list beginning at 9:30 AM before Honorable Sylvia H. Rambo. Discovery due by 3/30/2007. Dispositive Mts ddl 7/20/2007. PTMs due by 9/7/2007. PTC rescheduled for 9/14/2007 @ 10:00 AM before Honorable Sylvia H. Rambo. See order for other ddls. Signed by Judge Sylvia H. Rambo on 03/02/07. (ma,) (Entered: 03/02/2007)

03/08/2007 32 AMENDED COMPLAINT against NARTRON CORPORATION, filed by QRG, LTD..(Falsetti, Andrew) (Entered: 03/08/2007)

03/19/2007 33 ANSWER to Amended Complaint, COUNTERCLAIM against all defendants by NARTRON CORPORATION.(Grace, Mark) (Entered: 03/19/2007)

03/20/2007 -- Correction made to docket sheet to reflect QRG, LTD. as the Counterclaim Defendant with appropriate counsel listed as per the 3/19/07 Amended Complaint and Counterclaim 33 . (dfm) (Entered: 03/20/2007)

03/23/2007 34 MOTION to Strike Counterclaim by QRG, LTD.. (Attachments: # 1 Exhibit(s) A# 2 Exhibit(s) B# 3 Exhibit(s) C# 4 Exhibit(s) D# 5 Brief in Support# 6 Proposed Order)(Falsetti, Andrew) (Entered: 03/23/2007)

03/26/2007 35 BRIEF IN SUPPORT re 34 MOTION to Strike Counterclaim filed by QRG, LTD..(Falsetti, Andrew) (Entered: 03/26/2007)

03/29/2007 36 REPLY BRIEF re 34 MOTION to Strike Counterclaim filed by NARTRON CORPORATION. (Attachments: # 1 Exhibit(s) A# 2 Exhibit(s) B# 3 Exhibit(s) C - Part 1# 4 Exhibit(s) C - Part 2# 5 Exhibit(s) D# 6 Exhibit(s) E# 7 Exhibit(s) F# 8 Exhibit(s) G# 9 Exhibit(s) H# 10 Exhibit(s) I) (Grace, Mark) (Entered: 03/29/2007)

03/29/2007 37 CERTIFICATE of of Compliance by NARTRON CORPORATION re 36 Reply Brief,. (Grace, Mark) (Entered: 03/29/2007)

04/12/2007 38 REPLY BRIEF re 34 MOTION to Strike Counterclaim filed by QRG, LTD..(Falsetti, Andrew) (Entered: 04/12/2007)

04/23/2007 39 MEMORANDUM AND ORDER denying pltf's Motion to Strike 34 .Signed by Judge Sylvia H. Rambo on 04/23/07 (ma,) (Entered: 04/23/2007)

04/23/2007 40 NOTICE: A scheduling Conference has been scheduled for 5/10/2007 @ 9:00 AM before

Thursday, August 30, 2012

- Honorable Sylvia H. Rambo. This conference is by phone with the call to be initiated by the pltf. Signed by Judge Sylvia H. Rambo on 04/23/07. (ma,) (Entered: 04/23/2007)
- 05/07/2007 41 REPLY/ ANSWER to Counterclaim for Patent Infringement by QRG, LTD..(Falsetti, Andrew) (Entered: 05/07/2007)
- 05/07/2007 42 MOTION for Partial Summary Judgment on Plaintiff QRG's Declaratory Judgment Claim for Unenforceability of The Five Nartron Patents-In-Suit by NARTRON CORPORATION.(Grace, Mark) (Entered: 05/07/2007)
- 05/07/2007 43 STATEMENT OF FACTS re 42 MOTION for Partial Summary Judgment on Plaintiff QRG's Declaratory Judgment Claim for Unenforceability of The Five Nartron Patents-In-Suit filed by NARTRON CORPORATION. (Attachments: # 1 Index of Exhibits# 2 Exhibit(s) A# 3 Exhibit(s) B# 4 Exhibit(s) C)(Grace, Mark) (Entered: 05/07/2007)
- 05/07/2007 44 BRIEF IN SUPPORT re 42 MOTION for Partial Summary Judgment on Plaintiff QRG's Declaratory Judgment Claim for Unenforceability of The Five Nartron Patents-In-Suit filed by NARTRON CORPORATION.(Grace, Mark) (Entered: 05/07/2007)
- 05/07/2007 45 EXHIBIT A to Brief in Support by NARTRON CORPORATION re 44 Brief in Support. (Grace, Mark) (Entered: 05/07/2007)
- 05/07/2007 46 EXHIBIT PROPOSED ORDER by NARTRON CORPORATION re 42 MOTION for Partial Summary Judgment on Plaintiff QRG's Declaratory Judgment Claim for Unenforceability of The Five Nartron Patents-In-Suit. (Grace, Mark) (Entered: 05/07/2007)
- 05/07/2007 47 MOTION for Partial Summary Judgment that the Nartron Patents-In-Suit Are Not Invalid by NARTRON CORPORATION. (Attachments: # 1 Proposed Order)(Grace, Mark) (Entered: 05/07/2007)
- 05/07/2007 48 STATEMENT OF FACTS re 47 MOTION for Partial Summary Judgment that the Nartron Patents-In-Suit Are Not Invalid filed by NARTRON CORPORATION. (Attachments: # 1 Index# 2 Exhibit(s) A# 3 Exhibit(s) B# 4 Exhibit(s) C# 5 Exhibit(s) D# 6 Exhibit(s) E)(Grace, Mark) (Entered: 05/07/2007)
- 05/07/2007 49 BRIEF IN SUPPORT re 47 MOTION for Partial Summary Judgment that the Nartron Patents-In-Suit Are Not Invalid filed by NARTRON CORPORATION. (Attachments: # 1 Exhibit(s) A)(Grace, Mark) (Entered: 05/07/2007)
- 05/08/2007 50 CERTIFICATE of Compliance with Word-Count Limit by NARTRON CORPORATION re 44 Brief in Support. (Grace, Mark) (Entered: 05/08/2007)
- 05/08/2007 51 CERTIFICATE of Compliance with Word-Count Limit by NARTRON CORPORATION re 49 Brief in Support. (Grace, Mark) (Entered: 05/08/2007)
- 05/08/2007 -- Pursuant to the Local Rules and ECF User Manual, all motions and briefs should be filed simultaneously with their corresponding proposed orders, exhibits and any certificates as attachments to the main documents and not as individual documents. (dfm) (Entered: 05/08/2007)
- 05/10/2007 54 ORDER: 1) The fact discovery ddl shall be ext'd to (90) days from the date of this order; 2) W/i (30) days of this order, the parties shall depose Mr. Ingraham, an inventor; 3) W/i (30) days of this order, the parties shall jointly determine whether the issues and patents involved in this case can be narrowed; 4) A telephonic status conference shall take place on 6/26/07, at 9:30 a.m. Pltf shall initiate the call; 5) Briefing of Nartrons two partial mtns for sum jgm (Docs. 42 and 47) is STAYED until 8/17/07. On or before that date, Nartron shall notify the crt and QRG whether it intends to rely upon the mtns as they are, or withdraw the mtns and file a new dispositive mtn. If Nartronelects to file a new dispositive mtn, it must do so by 8/17/07. If Nartron leaves the mtns as they are, briefing will resume in accord w/LRs and QRGs responses will be due on or before 9/4/07; 6) The case management deadlines are amended as follows: Jury Selection/Trial Date December 3, 2007@ 9:30 AM Fact Discovery Ddl 8/10/07; Amended Dispositive Mtns & Brsups 08/17/07; Pltfs Expert Reports 08/24/07; Dfts Expert Reports 09/7/07; Supplemental Reports 09/21/07; Mtns in Limine & Brsups 10/09/07; Mtns in Limine Response 10/19/07; Mtns in Limine Reply 10/26/07; P-T Conference 11/16/07@ 11:00 AM; P-T Memoranda 11/9/07; Signed by Judge Sylvia H. Rambo on 05/10/07. (ma,) (Entered: 05/10/2007)
- 06/14/2007 55 STATUS REPORT to the Court on Narrowing of Issues and Patents Involved, and Request for Order for Mandatory Rule 26(a)(1) Disclosures by the Parties by NARTRON CORPORATION. (Attachments: # 1 Exhibit(s) A# 2 Exhibit(s) B# 3 Exhibit(s) C# 4 Exhibit(s) D)(Grace, Mark) (Entered: 06/14/2007)
- 06/19/2007 56 ORDER: Pltf QRG, Ltd. a/k/a Quantum Research Group, Ltd. shall respond to the points and proposals set forth in Nartrons status report 55 and proposed order no later than July 9, 2007. Signed by Judge Sylvia H. Rambo on 06/19/07. (ma,) (Entered: 06/19/2007)
- 07/09/2007 58 NOTICE by QRG, LTD. in Response to Nartron's Report and Proposed Order (Attachments: # 1 Word-Count Certificate# 2 Proposed Order # 3 Exhibit(s) 1# 4 Exhibit(s) 2# 5 Exhibit(s) 3# 6 Exhibit(s) 4# 7 Exhibit(s) 5# 8 Exhibit(s) 6# 9 Exhibit(s) 8# 10 Exhibit(s) 9# 11 Exhibit(s) 10# 12 Exhibit(s) 11# 13 Exhibit(s) 12# 14 Exhibit(s) 7)(Falsetti, Andrew) (Entered: 07/09/2007)

Thursday, August 30, 2012

- 07/13/2007 59 RESPONSE by NARTRON CORPORATION to 58 Notice,. (Attachments: # 1 Exhibit(s) 1-4)(Grace, Mark) (Entered: 07/13/2007)
- 07/27/2007 60 Joint MOTION for Extension of Time to Complete Discovery by QRG, LTD.. (Attachments: # 1 Proposed Order)(Falsetti, Andrew) (Entered: 07/27/2007)
- 08/01/2007 61 MEMORANDUM AND ORDER: 1) The claims and counterclaim in the captioned case are limited to those involving QRGs QProx E2SR, QT110, QT113, QT9701, and QT1106 products, and Nartron patents U.S. patents: 4,731,548; 4,758,735; 4,831,279; 5,087,825; 5,796,183. All other claims are DISMISSED for lack of subject matter jurisdiction. 2) Defendant Nartron Corporations Motion for Partial Summary Judgment on Plaintiff QRGs Declaratory Judgment Claim for Unenforceability of the Five Nartron Patents-in-Suit 42 and Motion for Partial Summary Judgment that the Nartron Patents-in-Suit are not Invalid 47 are STRICKEN. 3) Disposition of the parties Joint Motion to Revise Case Management Order 60 is deferred pending the outcome of mediation. 4) The parties shall notify the court no later than August 10, 2007, whether they intend to obtain their own mediator or request the court to appoint a mediator. 5) Mediation shall be completed no later than September 14, 2007. Signed by Judge Sylvia H. Rambo on 08/01/07 (ma,) (Entered: 08/01/2007)
- 08/10/2007 62 NOTICE by QRG, LTD. and Nartron Corporation Regarding Mediator Selection (Falsetti, Andrew) (Entered: 08/10/2007)
- 09/26/2007 63 STATUS REPORT by NARTRON CORPORATION. (Grace, Mark) (Entered: 09/26/2007)
- 10/22/2007 64 STATUS REPORT (Joint) by NARTRON CORPORATION. (Grace, Mark) (Entered: 10/22/2007)
- 10/23/2007 65 PETITION FOR SPECIAL ADMISSION (PRO HAC VICE) by Clay P. Hughes on behalf of QRG, LTD. Attorney Clay Hughes is seeking special admission. Filing fee \$ 25, receipt number 1136392.. (Hughes, Clay) (Entered: 10/23/2007)
- 10/23/2007 66 ATTORNEY SUBSTITUTION - Withdrawal and Entry of Attorney Appearance. Attorney Andrew E. Falsetti terminated. Attorney Clay P. Hughes and Clay P. Hughes for QRG, LTD. added. (Hughes, Clay) (Entered: 10/23/2007)
- 10/23/2007 67 SPECIAL ADMISSIONS FORM APPROVED as to Clay Hughes, Esq. on behalf of QRG Signed by Judge Sylvia H. Rambo on 10/23/07. (ma,) (Entered: 10/23/2007)
- 11/28/2007 68 STIPULATION of Dismissal with Prejudice by NARTRON CORPORATION. (Grace, Mark) (Entered: 11/28/2007)
- 11/28/2007 69 ORDER APPROVING STIPULATION OF DISMISSAL. Signed by all parties. Case termed. Signed by Judge Sylvia H. Rambo on 11/28/07. (ma,) (Entered: 11/28/2007)

Copyright © 2012 LexisNexis CourtLink, Inc. All rights reserved.
 *** THIS DATA IS FOR INFORMATIONAL PURPOSES ONLY ***

US District Court Civil Docket

U.S. District - Pennsylvania Western
(Pittsburgh)

2:06cv500

Qrg, Ltd v. Nartron Corporation

This case was retrieved from the court on Wednesday, May 07, 2008

Date Filed: **04/13/2006** Class Code: **CLOSED**
Assigned To: **Donetta W Ambrose** Closed: **Yes**
Referred To: Statute: **28:2201**
Nature of suit: **Patent (830)** Jury Demand: **Plaintiff**
Cause: **Declaratory Judgment** Demand Amount: **\$0**
Lead Docket: **None** NOS Description: **Patent**
Other Docket: **None**
Jurisdiction: **Federal Question**

Litigants

Attorneys

Qrg, Ltd
Plaintiff

Andrew E Falsetti
[COR LD NTC]
Reed Smith
435 Sixth Avenue
Pittsburgh, PA 15219-1886
USA
(412) 288-3844
Fax: (412) 288-3063
Email: Afalsetti@reedsmith.com

Nartron Corporation
Defendant

Mark A Grace
[COR LD NTC]
Cohen & Grigsby
11 Stanwix Street
15TH Floor
Pittsburgh, PA 15222-1319
USA
(412) 297-4838
Fax: (412) 209-1838
Email: MGRACE@COHENLAW.COM

Thomas C Wettach
[COR LD NTC]
Cohen & Grigsby
11 Stanwix Street
15TH Floor
Pittsburgh, PA 15222-1319
USA
(412) 297-4840
Email: Twettach@cohenlaw.com

Date	#	Proceeding Text	Source
04/13/2006	1	COMPLAINT against NARTRON CORPORATION (Filing fee \$ 350 receipt number 3312.) filed by QRG, LTD.. (Attachments: # 1 Civil Cover Sheet # 2 Receipt #3312)(jsp) (Entered: 04/14/2006)	
04/13/2006	2	Disclosure Statement by QRG, LTD. (jsp) (Entered: 04/14/2006)	

Thursday, August 30, 2012

04/14/2006 -- Summons Issued as to NARTRON CORPORATION. (jsp) (Entered: 04/14/2006)

04/14/2006 -- Remark: E-mail notification to the U.S. Patent and Trademark Office with complaint and docket entries attached sent this date. (jsp,) (Entered: 04/14/2006)

04/24/2006 3 SUMMONS/Return of Service Returned Executed by QRG, LTD.. NARTRON CORPORATION served on 4/18/2006, answer due 5/8/2006. (Tabachnick, Gene) (Entered: 04/24/2006)

05/08/2006 4 MOTION to Dismiss Pursuant to Fed.R.Civ.P. 12(b)(2) by NARTRON CORPORATION. (Attachments: # 1 Proposed Order (Grace, Mark) (Entered: 05/08/2006)

05/08/2006 5 BRIEF in Support re 4 MOTION to Dismiss Pursuant to Fed.R.Civ.P. 12(b)(2) filed by NARTRON CORPORATION. (Attachments: # 1 Exhibit A# 2 Exhibit B# 3 Exhibit C)(Grace, Mark) (Entered: 05/08/2006)

05/09/2006 6 NOTICE of Appearance by Thomas C. Wettach on behalf of NARTRON CORPORATION (Wettach, Thomas) (Entered: 05/09/2006)

05/09/2006 7 NOTICE: Response to Defendant's Motion to Dismiss (Docket No. 4) due by 5/30/2006. (jlh) (Entered: 05/09/2006)

05/12/2006 8 MOTION for Discovery on Personal Jurisdiction by QRG, LTD.. (Attachments: # 1 Proposed Order # 2 Exhibit 1# 3 Exhibit 2# 4 Exhibit 3# 5 Exhibit 4# 6 Exhibit 5# 7 Exhibit 6# 8 Exhibit 7# 9 Exhibit 8# 10 Exhibit 9)(Falsetti, Andrew) (Entered: 05/12/2006)

05/22/2006 9 NOTICE: Response to Plaintiff's Motion for Leave to Take Discovery on the Personal Jurisdiction Issue Raised by Defendant's Motion to Dismiss shall be due by 5/29/2006. In addition, the Plaintiff's response to the Defendant's Motion to Dismiss shall be continued from May 30, 2006 until a date set forth in a future order of this court. (jlh) (Entered: 05/22/2006)

05/26/2006 10 BRIEF in Opposition re 8 MOTION for Discovery on Personal Jurisdiction filed by NARTRON CORPORATION. (Attachments: # 1 Exhibit A# 2 Exhibit B# 3 Exhibit C# 4 Exhibit D)(Grace, Mark) (Entered: 05/26/2006)

05/30/2006 11 ORDER granting 8 Motion for Discovery (as stated more fully in order). Signed by Judge Donetta W. Ambrose on 5/30/06. (jlh) (Entered: 05/30/2006)

05/30/2006 -- Response to Motion to Dismiss due by 7/30/2006. (jlh) (Entered: 05/30/2006)

07/31/2006 12 BRIEF in Opposition re 4 MOTION to Dismiss Pursuant to Fed.R.Civ.P. 12(b)(2) filed by QRG, LTD.. (Attachments: # 1 Exhibit A# 2 Exhibit B# 3 Exhibit C# 4 Affidavit /Declaration of Richard T. Ting in Support of Qrg's Opposition to Defendant's Motion to Dismiss# 5 Affidavit /Declaration of Andrew E. Falsetti in Support of Qrg's Opposition to Defendant's Motion to Dismiss# 6 Affidavit /Declaration of Harald Philipp in Support of Qrg's Opposition to Defendant's Motion to Dismiss# 7 Affidavit /Declaration of Chris Bede in Support of QRG's Opposition to Defendant's Motion to Dismiss)(Falsetti, Andrew) (Entered: 07/31/2006)

08/04/2006 13 MOTION for Leave to File A Brief in Reply to Plaintiff QRG's Opposition to Defendant's Motion to Dismiss by NARTRON CORPORATION. (Attachments: # 1 Exhibit A)(Grace, Mark) (Entered: 08/04/2006)

08/07/2006 14 RESPONSE to Motion re 13 MOTION for Leave to File A Brief in Reply to Plaintiff QRG's Opposition to Defendant's Motion to Dismiss filed by QRG, LTD.. (Attachments: # 1 Affidavit /Supplemental Declaration of Richard T. Ting)(Falsetti, Andrew) (Entered: 08/07/2006)

08/09/2006 15 ORDER granting 13 Motion for Leave to File Reply Brief . Signed by Judge Donetta W. Ambrose on 8/8/06. (jlh) (Entered: 08/09/2006)

08/09/2006 16 BRIEF IN REPLY to Response to Motion re 4 MOTION to Dismiss Pursuant to Fed.R.Civ.P. 12(b)(2) filed by NARTRON CORPORATION. (Attachments: # 1 Exhibit A)(Grace, Mark) Modified text to reflect title of document on 8/10/2006 (jsp,). (Entered: 08/09/2006)

09/07/2006 17 ORDER denying 4 Motion to Dismiss, as set forth more fully in the Opinion accompanying this Order; It is further ORDERED that the within case is transferred to the United States District Court for the Middle District of Pennsylvania. The Clerk of Court is directed to transfer this case forthwith to the U.S. District Court for the Middle District of Pennsylvania. Signed by Judge Donetta W. Ambrose, Chief Judge, on 09/07/2006. (adb) (Entered: 09/07/2006)

09/07/2006 -- Case transferred to District of USDC Middle District of PA. Original file, certified copy of transfer order, retrieval instructions and docket sheet sent. (jsp) (Entered: 09/07/2006)

09/07/2006 -- Remark: E-mail notification to the U.S. Patent and Trademark Office with copy of order transferring this action to the USDC for the Middle District of Pennsylvania sent on September 7, 2006. (jsp) (Entered: 09/07/2006)

1. 4963097, October 16, 1990, Display apparatus for a group education system, Anju, Shinji, Saitama, Japan(JP); 869449, Sony Corporation, Tokyo, Japan(JP)

CORE TERMS: display, seat, screen, designated, symbol, cursor, displayed, switch, electrode, classroom, correspond, column, row, assigned, actuation, terminal, seating, designatable, stored, microcomputer, array, teacher, console, actuated; memory, corner, designation, switching, seated, select

2. 7287216, October 23, 2007, Dynamic XML processing system, Lee, Wai-Kwong (Sam), Nashua, New Hampshire, United States of America(US), United States of America(); Carrer, Marco, Nashua, New Hampshire, United States of America(US), United States of America(); Srivastava, Alok, Chelmsford, Massachusetts, United States of America(US), United States of America(); Lin, Paul, Nashua, New Hampshire, United States of America(US), United States of America(); Han, Cheng, Nashua, New Hampshire, United States of America(US), United States of America(); 583245, November 16, 2005, ASSIGNMENT OF ASSIGNORS INTEREST (SEE DOCUMENT FOR DETAILS)., ORACLE INTERNATIONAL CORPORATION, M/S 50P7, 500 ORACLE PARKWAY, REDWOOD SHORES, CALIFORNIA, UNITED STATES OF AMERICA(US), 94065, reel-frame:016797/0172; November 16, 2005, ASSIGNMENT OF ASSIGNORS INTEREST (SEE DOCUMENT FOR DETAILS)., ORACLE INTERNATIONAL CORPORATION, M/S 50P7, 500 ORACLE PARKWAY, REDWOOD SHORES, CALIFORNIA, UNITED STATES OF AMERICA(US), 94065, reel-frame:017366/0283, Oracle International Corp., Redwood Shores, California, United States of America(US), United States company or corporation

CORE TERMS: relational, stored, descriptor, database, skeleton, row, uid, column, leaf, path, lastname, schema, dynamically, query, separately, storage, updated, retrieved, referential, deleted, retrieve, named, user, illustrative, processing, designated, retrieval, deletion, specify, selects

3. 7110585, September 19, 2006, Nanoparticle imaging system and method, Cork, William, Lake Bluff, Illinois, United States of America(US), United States of America(); Patno, Tim, Evanston, Illinois, United States of America(US), United States of America(); Weber, Mark, Algonquin, Illinois, United States of America(US), United States of America(); Morrow, Dave, Chicago, Illinois, United States of America(US), United States of America(); Buckingham, Wesley, Chicago, Illinois, United States of America(US), United States of America(); 210959, October 31, 2002, ASSIGNMENT OF ASSIGNORS INTEREST (SEE DOCUMENT FOR DETAILS)., NANOSPHERE, INC. 1818 SKOKIE BLVD, SUITE 200 NORTHBROOK ILLINOIS 60062, reel-frame:013448/0602, Nanosphere, Inc., Northbrook, Illinois, United States of America(US), United States company or corporation, April 24, 2007, SECURITY INTEREST (SEE DOCUMENT FOR DETAILS)., VENTURE LENDING & LEASING IV, INC. 2010 NORTH FIRST STREET SAN JOSE CALIFORNIA 95131, 2010 NORTH FIRST STREET, SAN JOSE, CALIFORNIA, UNITED STATES OF AMERICA(US), 95131, reel-frame:019227/0165

CORE TERMS: spot, substrate, pixel, nanoparticle, exposure, sensor, imaging, module, blob, row, distortion, target, detection, sample, optimal, detected, alignment, probe, photosensor, oligonucleotide, nucleic acid, sequence, software, illumination, prime, acquired, identification, intensity, analyte, gap

4. 7773790, August 10, 2010, Method for detecting the presence of a target analyte in a test spot, Cork, William, Lake Bluff, Illinois, United States of America(US), United States of America(); Patno, Tim, Chicago, Illinois, United States of America(US), United States of America(); Weber, Mark, Cary, Illinois, United States of America(US), United States of America(); Morrow, Dave, Chicago, Illinois, United States of America(US), United States of America(); Buckingham, Wesley, Chicago, Illinois, United States of America(US), United States of America(); 530110, September 8, 2006, ASSIGNMENT OF ASSIGNORS INTEREST (SEE DOCUMENT FOR DETAILS)., NANOSPHERE, INC., 4088 COMMERCIAL AVENUE, NORTHBROOK, ILLINOIS, UNITED STATES OF AMERICA(US), 60062, reel-frame:018221/0083; April 24, 2007, SECURITY INTEREST (SEE DOCUMENT FOR DETAILS)., VENTURE LENDING & LEASING V, INC., 2010 NORTH FIRST STREET, SAN JOSE, CALIFORNIA, UNITED STATES OF AMERICA (US), 95131, reel-frame:019227/0165, Nanosphere, Inc., Northbrook, Illinois, United States

of America(US), United States company or corporation

CORE TERMS: spot, substrate, pixel, nanoparticle, exposure, sensor, imaging, module, blob, row, distortion, target, detection, sample, optimal, detected, alignment, probe, photosensor, oligonucleotide, nucleic acid, sequence, software, prime, illumination, acquired, analyte, identification, intensity, gap

5. 4930390, June 5, 1990, Automatic musical performance apparatus having separate level data storage, Kellogg, Steven L., Santa Cruz, United States of America(US); Kellogg, Jack A., Santa Cruz, United States of America(US); 300115, February 24, 1989, ASSIGNMENT OF ASSIGNORS INTEREST., YAMAHA CORPORATION, 10-1, NAKAZAWA-CHO, HAMAMATSU-SHI, SHIZUOKA-KEN, JAPAN, A CORP. OF JAPAN, A CORP. OF JAPAN, 10-1, NAKAZAWA-CHO, HAMAMATSU-SHI, SHIZUOKA-KEN, JAPAN(), reel-frame:005024/0262, Yamaha Corporation, Hamamatsu, Japan(JP)

CORE TERMS: register, song, switch, track, tone, performer, memory, velocity, duration, slider, sequence, routine, zero, designate, automatic, screen, musical, continuous, displayed, tone colors, generator, cursor, musical performance, depressed, clock, generating, keyboard, starting, tempo, denote

6. 20080020380 (Note: This is a Patent Application only.), January 24, 2008, Method of denaturing and fragmenting DNA or RNA using ultrasound, Patno, Tim, Chicago, Illinois, United States of America(US), United States of America(); Westberg, Tom, Gurnee, Illinois, United States of America(US), United States of America(); Halblander, Michael F., Des Plaines, Illinois, United States of America(US), United States of America(); Beeson, Emily R., Chicago, Illinois, United States of America(US), United States of America(); Rush, Benjamin L., Evanston, Illinois, United States of America(US), United States of America(); 491565, September 21, 2006, ASSIGNMENT OF ASSIGNORS INTEREST (SEE DOCUMENT FOR DETAILS)., NANOSPHERE, INC., 4088 COMMERCIAL AVENUE, NORTHBROOK, ILLINOIS, UNITED STATES OF AMERICA(US), 60062, reel-frame:018327/0694; April 24, 2007, SECURITY INTEREST (SEE DOCUMENT FOR DETAILS)., VENTURE LENDING & LEASING V, INC., 2010 NORTH FIRST STREET, SAN JOSE, CALIFORNIA, UNITED STATES OF AMERICA (US), 95131, reel-frame:019227/0165, PATNO TIM; WESTBERG TOM; HALBLANDER MICHAEL F; BEESON EMILY R; RUSH BENJAMIN L

CORE TERMS: sample, acoustic, module, processing, denaturing, hybridization, nucleic acids, energy, cap, oligonucleotide, ultrasonic, conduit, fluid, chamber, nanoparticles, coupling, sequence, probe, ultrasound, disease, emitter, pin, transmission, fragmenting, denature, horn, time period, detecting, detection, genetic

7. 20050170493 (Note: This is a Patent Application only.), August 4, 2005, Disposable sample processing module for detecting nucleic acids, Patno, Tim, Chicago, Illinois, United States of America(US), United States of America(); Westberg, Tom, Gurnee, Illinois, United States of America(US), United States of America(); 982292, November 5, 2004, ASSIGNMENT OF ASSIGNORS INTEREST (SEE DOCUMENT FOR DETAILS)., NANOSPHERE, INC. 4088 COMMERCIAL AVENUE NORTHBROOK ILLINOIS 60062, 4088 COMMERCIAL AVENUE, NORTHBROOK, ILLINOIS, UNITED STATES OF AMERICA(US), 60062, reel-frame:015955/0521, PATNO TIM; WESTBERG TOM, April 24, 2007, SECURITY INTEREST (SEE DOCUMENT FOR DETAILS)., VENTURE LENDING & LEASING V, INC., 2010 NORTH FIRST STREET, SAN JOSE, CALIFORNIA, UNITED STATES OF AMERICA(US), 95131, reel-frame:019227/0165

CORE TERMS: sample, hybridization, chamber, module, processing, fluid, nucleic acids, valve plate, oligonucleotide, aperture, gasket, nozzle, substrate, pumping, port, connect, nanoparticles, probe, passageway, disease, detecting, sequence, channels, fill, hybridized, disposable, detection, manifold, genetic, target

8. 20050112583 (Note: This is a Patent Application only.), May 26, 2005, Method of preparing nucleic acids for detection, Patno, Tim, Chicago, Illinois, United States of America(US), United States of America(); Hollenstein, Jennifer, Grayslake, Illinois, United States of America(US), United States of America(); Kronshage, Christian, Round Lake, Illinois, United States of

America(US), United States of America(); Khoury, Christopher, Chicago, Illinois, United States of America(US), United States of America(); Weber, Mark, Algonquin, Illinois, United States of America(US), United States of America(); Westberg, Tom, Gurnee, Illinois, United States of America(US), United States of America(); Cork, William, Lake Bluff, Illinois, United States of America(US), United States of America(); 703368, November 7, 2003, ASSIGNMENT OF ASSIGNORS INTEREST (SEE DOCUMENT FOR DETAILS)., NANOSPHERE, INC. 4088 COMMERCIAL AVENUE NORTHBROOK ILLINOIS 60062, 4088 COMMERCIAL AVENUE, NORTHBROOK, ILLINOIS, UNITED STATES OF AMERICA(US), 60062, reel-frame:014679/0650, PATNO TIM; HOLLENSTEIN JENNIFER; KRONSHAGE CHRISTIAN; KHOURY CHRISTOPHER; WEBER MARK; WESTBERG TOM; CORK WILLIAM, April 24, 2007, SECURITY INTEREST (SEE DOCUMENT FOR DETAILS)., VENTURE LENDING & LEASING V, INC., 2010 NORTH FIRST STREET, SAN JOSE, CALIFORNIA, UNITED STATES OF AMERICA (US), 95131, reel-frame:019227/0165

CORE TERMS: sample, hybridization, pump, port, processing, chamber, fluid, valve, nucleic acids, waste, silver, manifold, controller, target, hybridized, oligonucleotide, probe, forms a connection, nanoparticle, substrate, container, detecting, channel, empty, user, detection, syringe, connect, heating, execute

9. 20030224505 (Note: This is a Patent Application only.), December 4, 2003, DNA hybridization device and method, Patno, Tim, Evanston, Illinois, United States of America(); Fisher, Mark, Highland Park, Illinois, United States of America(); Maung, George Kyaw Soe, Chicago, Illinois, United States of America(); Westberg, Tom, Gurnee, Illinois, United States of America(); 352714, June 16, 2003, ASSIGNMENT OF ASSIGNORS INTEREST (SEE DOCUMENT FOR DETAILS)., NANOSPHERE, INC. 1818 SKOKIE BLVD, SUITE 200 NORTHBROOK, ILLINOIS, 60062, 1818 SKOKIE BLVD, SUITE 200, NORTHBROOK, ILLINOIS, UNITED STATES OF AMERICA(US), 60062, reel-frame:014194/0215, PATNO TIM; FISHER MARK; MAUNG GEORGE KYAW SOE; WESTBERG TOM, January 26, 2005, CORRECTIVE ASSIGNMENT TO CORRECT THE THE NAME OF MR. GEORGE KYAW SOE MAUNG AYE ON THE ASSIGNMENT PREVIOUSLY RECORDED ON REEL 014194 FRAME 0215. ASSIGNOR(S) HEREBY CONFIRMS THE OWNERSHIP OF THE ENTIRE INTEREST., NANOSPHERE, INC. 4088 COMMERCIAL AVENUE NORTHBROOK, ILLINOIS, 60062, 4088 COMMERCIAL AVENUE, NORTHBROOK, ILLINOIS, UNITED STATES OF AMERICA(US), 60062, reel-frame:015606/0873; April 24, 2007, SECURITY INTEREST (SEE DOCUMENT FOR DETAILS)., VENTURE LENDING & LEASING V, INC., 2010 NORTH FIRST STREET, SAN JOSE, CALIFORNIA, UNITED STATES OF AMERICA (US), 95131, reel-frame:019227/0165

CORE TERMS: substrate, hybridization, chamber, holder, slide, pliable, sidewall, cap, rigid, user, bath, gasket, seal, probe, alternatively, bracket, neck, clamp, curved, fluid, abut, flexible, sealing, imaging, lip, inserted, sample, target, composed, enhancement

10. 20030068638 (Note: This is a Patent Application only.), April 10, 2003, Nanoparticle imaging system and method, Cork, William, Lake Bluff, Illinois, United States of America(); Patno, Tim, Evanston, Illinois, United States of America(); Weber, Mark, Algonquin, Illinois, United States of America(); Morrow, Dave, Chicago, Illinois, United States of America(); Buckingham, Wesley, Chicago, Illinois, United States of America(); 210959, October 31, 2002, ASSIGNMENT OF ASSIGNORS INTEREST (SEE DOCUMENT FOR DETAILS)., NANOSPHERE, INC., 1818 SKOKIE BLVD, SUITE 200, NORTHBROOK, ILLINOIS, UNITED STATES OF AMERICA (US), 60062, reel-frame:013448/0602, CORK WILLIAM; PATNO TIM; WEBER MARK; MORROW DAVE; BUCKINGHAM WESLEY, April 24, 2007, SECURITY INTEREST (SEE DOCUMENT FOR DETAILS)., VENTURE LENDING & LEASING V, INC., 2010 NORTH FIRST STREET, SAN JOSE, CALIFORNIA, UNITED STATES OF AMERICA(US), 95131, reel-frame:019227/0165

CORE TERMS: spot, substrate, pixel, nanoparticle, exposure, sensor, imaging, module, blob, row, distortion, target, detection, sample, optimal, detected, alignment, probe, photosensor, oligonucleotide, nucleic acid, sequence, software, illumination, prime, acquired, identification, intensity, analyte, gap

Source: [Legal > Area of Law - By Topic > Patent Law > Find Patents > Utility, Design and Plant Patents](#) [i](#)

Terms: **patno=5796183** (Suggest Terms for My Search)
View: Cite
Date/Time: Thursday, August 30, 2012 - 12:27 PM EDT

In

[About LexisNexis](#) | [Privacy Policy](#) | [Terms & Conditions](#) | [Contact Us](#)
Copyright © 2012 LexisNexis, a division of Reed Elsevier Inc. All rights reserved.

1. Five Star Quality Care, Inc. Announces Lease Realignment Agreement With Senior Housing Properties Trust, Business Wire, August 4, 2009 Tuesday 8:05 PM GMT, , 1467 words, NEWTON, Mass.
2. US Swaptions: Real Vol Delivers, Light Short Cover Support, The Main Wire, May 19, 2011 Thursday 12:21 PM GMT, , 636 words, CHICAGO May 19
3. N.D. STATE GIRLS GOLF TOURNAMENT, Grand Forks Herald, October 5, 2005 Wednesday, SPT, 549 words
4. State Girls A Golf Results, The Associated Press State & Local Wire, October 4, 2005, Tuesday, BC cycle, Sports News, 525 words, GRAND FORKS, N.D.
5. Page 16 Issue No. 796, Coal Americas, January 24, 1991, 179 words
6. Stocks NZ Close 3, AAP NEWSFEED, February 16, 2001, Friday, Nationwide General News; Finance Wire, 1280 words
7. Shelter for your pets, St. Petersburg Times (Florida), June 1, 1997, Sunday, SPECIAL SECTION; HURRICANE '97; Pg. 17I, 391 words
8. US Swaptions: OTC Vol Off Early Highs, Light Gamma Sales, The Main Wire, April 28, 2010 Wednesday 12:08 PM GMT, , 558 words, CHICAGO
9. Shelter available for pets, St. Petersburg Times (Florida), May 31, 1998, Sunday, SPECIAL SECTION; 1998 HURRICANE GUIDE: THE STORM APPROACHES; Pg. 18I, 377 words
10. Five Star Quality Care, Inc. Announces Annual Meeting Results, Business Wire, May 10, 2010 Monday 9:00 PM GMT, , 183 words, NEWTON, Mass.

Source: **News & Business > Combined Sources > News, All (English, Full Text)** 

Terms: **5796183 or 5,796,183** (Suggest Terms for My Search | Feedback on Your Search)

View: Cite

Date/Time: Thursday, August 30, 2012 - 12:28 PM EDT

In

About LexisNexis | Privacy Policy | Terms & Conditions | Contact Us
Copyright © 2012 LexisNexis, a division of Reed Elsevier Inc. All rights reserved.

1. Microstrategy Inc. v. Business Objects Ams., Civil Action No. 03-1124-KAJ , UNITED STATES DISTRICT COURT FOR THE DISTRICT OF DELAWARE, 410 F. Supp. 2d 348; 2006 U.S. Dist. LEXIS 2136, January 23, 2006, Decided , Affirmed by Microstrategy Inc. v. Bus. Objects Ams., 2007 U.S. App. LEXIS 15100 (Fed. Cir., June 25, 2007)

OVERVIEW: Summary judgment was granted in favor of defendant in patent infringement action on three patents. District court's claim construction resulted in finding of no infringement on one patent, and no genuine issues of fact existed as to defendant's argument that several claims in the other patents were invalid due to anticipation.

CORE TERMS: patent, user's, infringement, summary judgment, invalidity, asynchronously, reporting, interface, server, network ...

2. SSL Servs., ILC v. Citrix Sys., CIVIL ACTION NO. 2:08-cv-158-JRG, UNITED STATES DISTRICT COURT FOR THE EASTERN DISTRICT OF TEXAS, MARSHALL DIVISION, 2012 U.S. Dist. LEXIS 76965, June 4, 2012, Decided, June 4, 2012, Filed, Summary judgment denied by SSL Servs., LLC v. Citrix Sys., 2012 U.S. Dist. LEXIS 76970 (E.D. Tex., June 4, 2012)

CORE TERMS: non-infringing, patent, expert report, discovery requests, infringe, software, reliable, patents-in-suit, design-arounds, hardware ...

3. Ex parte Kuriappan P. Alappat, Edward E. Averill, and James G. Larsen, Appeal No. 91-1277 from Art Unit 231. ON BRIEF. Application for Patent filed January 29, 1988, Serial No. 07/149,792, for Raster Scan Waveform Display Rasterizer With Pixel Intensity Gradation., Board of Patent Appeals and Interferences, 1992 Pat. App. LEXIS 11; 23 U.S.P.Q.2D (BNA) 1340, April 22, 1992, On Reconsideration

CORE TERMS: apparatus, mathematical, algorithm, subject matter, recited, specification, invention, performing, recite, nonstatutory ...

4. In re Lanham, et al. Reexamination Proceeding, Control No. 90/000,883 Filed: October 11, 1985 For: U.S. Patent No. 3,440,973 Control No. 90/000,884 Filed: October 11, 1985 For: U.S. Patent No. 3,680,493, Commissioner of Patents and Trademarks, 1986 Commr. Pat. LEXIS 4; 1 U.S.P.Q.2D (BNA) 1877, October 31, 1986, Decided

CORE TERMS: reexamination, patent, printed, requester, legislative history, ex parte, patenting, double, set forth, inequitable conduct ...

5. Ex parte RICHARD DOUGLAS BARNES, Appeal 2007-3782 Application 10/755,554 n1 n1 Application filed January 12, 2004. The real party in interest is the inventor. Technology Center 2800, Board of Patent Appeals and Interferences, 2007 Pat. App. LEXIS 4482, November 20, 2007, Decided

CORE TERMS: suppression, examiner, earring, user, skill, ear, obviousness, glasses, worn, prima facie case ...

6. Certain Seamless Carbon and Alloy Standard, Line, and Pressure Steel Pipe from Argentina, Brazil, Germany, and Italy., Investigations Nos. 701-TA-362; 731-TA-707 through 710 (Preliminary), USITC PUBLICATION 2801, UNITED STATES INTERNATIONAL TRADE COMMISSION, 1994 ITC LEXIS 666, August 1994

7. Ex parte John Dash and Patrick S. Keefe, Appeal No. 92-3536 from Art Unit 2204 Application for Patent filed April 16, 1990, Serial No. 07/509,585. Low Temperature Nuclear Fusion., Board of Patent Appeals and Interferences, 1992 Pat. App. LEXIS 36; 27 U.S.P.Q.2D (BNA) 1481, November 24, 1992, Decided

CORE TERMS: examiner, electrolyte, fusion, invention, cold, energy, electrolysis, cell, nuclear fusion, specification ...

8. SSL Servs., LLC v. Citrix Sys., CIVIL ACTION NO. 2-08-cv-158-TJW, UNITED STATES

DISTRICT COURT FOR THE EASTERN DISTRICT OF TEXAS, MARSHALL DIVISION, 816 F. Supp. 2d 364; 2011 U.S. Dist. LEXIS 106725, September 20, 2011, Decided, September 20, 2011, Filed, Stay denied by SSL Servs., LLC v. Citrix Sys., 2012 U.S. Dist. LEXIS 35779 (E.D. Tex., Mar. 16, 2012)

OVERVIEW: In this patent infringement action, the court construed the disputed claim terms; the court construed "intercepting function calls and requests for service" to mean "using a shim to intercept or divert a request for a desired function, service, operation or event."

CORE TERMS: server, authentication, encryption, shim, session, specification, destination, layer, network, software ...

9. Ex parte RAJEEV BHIDE, DINESH V. PATEL and ERIC M. GORDON, Appeal No. 95-0796 Application No. 07/994,230 n1n1 Application for patent filed December 21, 1992., BOARD OF PATENT APPEALS AND INTERFERENCES, 1996 Pat. App. LEXIS 13; 42 U.S.P.Q.2D (BNA) 1441, January 31, 1996, Decided

CORE TERMS: compound, protein, farnesyl, examiner, transferase, specification, amino acid, cancer, peptide, cysteine ...

- I** 10. Ill. Computer Research, LLC v. HarperCollins Publr., Inc., Case No. 10 C 5021, UNITED STATES DISTRICT COURT FOR THE NORTHERN DISTRICT OF ILLINOIS, EASTERN DIVISION, 2010 U.S. Dist. LEXIS 124288, November 22, 2010, Decided, November 22, 2010, Filed

CORE TERMS: convenience, patent, website, place of business, non-party, venue, weigh, statistics, lawsuit, interest of justice ...

Source: [Legal > Area of Law - By Topic > Patent Law > Find Cases > Patent Cases from Federal Courts and Administrative Materials](#) **I**

Terms: **5796183** or **5,796,183** (Suggest Terms for My Search | Feedback on Your Search)

View: Cite

Date/Time: Thursday, August 30, 2012 - 12:28 PM EDT

* Signal Legend:

● - Warning: Negative treatment is indicated

Q - Questioned: Validity questioned by citing refs

△ - Caution: Possible negative treatment

◆ - Positive treatment is indicated

A - Citing Refs. With Analysis Available

I - Citation information available

* Click on any *Shepard's* signal to *Shepardize*® that case.

In

About LexisNexis | Privacy Policy | Terms & Conditions | Contact Us
Copyright © 2012 LexisNexis, a division of Reed Elsevier Inc. All rights reserved.

1. Copyright (c) 2010, American Intellectual Property Law Association. AIPLA QUARTERLY JOURNAL, 38 AIPLA Q. J. 471, PREDICTABILITY AND INTERACTIVITY: AN EXAMINATION OF ARISTA RECORDS, LLC V. LAUNCH MEDIA, INC., Ari Z. Moskowitz *
2. Copyright (c) 2001, American Intellectual Property Law Association. AIPLA QUARTERLY JOURNAL, 29 AIPLA Q. J. 375, A NEW WAY TO DETERMINE OBVIOUSNESS: APPLYING THE PIONEER DOCTRINE TO 35 U.S.C. § 103(a), By Samson Vermont *
3. Copyright (c) 2004 by the President and Fellows of Harvard College Harvard Journal of Law & Technology, Spring, 2004, 17 Harv. J. Law & Tec 533, 19215 words, NOTE: Don'T Just Hit Send: Unsolicited E-Mail and the Attorney-Client Relationship, Douglas K. Schnell *
4. Copyright (c) 2001, American Intellectual Property Law Association. AIPLA QUARTERLY JOURNAL, 29 AIPLA Q. J. 269, EFFECTIVE PREPARATION OF PATENT RELATED EXCULPATORY LEGAL OPINIONS, By Edward Poplawski *
5. Copyright (c) 1983, American Intellectual Property Law Association. AIPLA QUARTERLY JOURNAL, 11 AIPLA Q. J. 236, COPING WITH STATUTES WHICH "MUDDY THE WATERS" OF TRADEMARK PRACTICE *, by VERONICA COLBY DEVITT **
6. Copyright (c) 2009 by the President and Fellows of Harvard College Harvard Journal of Law & Technology, Fall, 2009, Harvard Journal of Law & Technology, 23 Harv. J. Law & Tec 179, 26230 words, ARTICLE: HIGHER STANDARDS REGULATION IN THE NETWORK AGE, By Kevin Werbach*
7. Copyright (c) 2011, American Intellectual Property Law Association. AIPLA QUARTERLY JOURNAL, 39 AIPLA Q. J. 511, ARTICLE: BELOW THE SURFACE OF THE ACTA: THE DANGERS THAT JUSTIFY NEW CRIMINAL SANCTIONS AGAINST INTELLECTUAL PROPERTY INFRINGEMENT, Ryan Rufo *
8. Copyright (c) 1999, American Intellectual Property Law Association. AIPLA QUARTERLY JOURNAL, 27 AIPLA Q. J. 1, ARTICLE: SELECTION AND USE OF EXPERTS IN PATENT CASES, Edward G. Poplawski *
9. Copyright (c) 1987, American Intellectual Property Law Association. AIPLA QUARTERLY JOURNAL, 15 AIPLA Q. J. 85, REEXAMINATION -- THE PATENT CHALLENGER'S VIEW, William J. Speranza * and Michael L. Goldman **
10. Copyright (c) 2009 by the President and Fellows of Harvard College Harvard Journal of Law & Technology, Spring, 2009, Harvard Journal of Law & Technology, 22 Harv. J. Law & Tec 381, 16409 words, ARTICLE: BRAND SPILLOVERS, Eric Goldman*

Source: **Legal > Area of Law - By Topic > Patent Law > Search News > Patent, Trademark & Copyright Periodicals, Combined** [\[i\]](#)

Terms: **5796183 or 5,796,183** (Suggest Terms for My Search | Feedback on Your Search)

View: Cite

Date/Time: Thursday, August 30, 2012 - 12:28 PM EDT

In

About LexisNexis | Privacy Policy | Terms & Conditions | Contact Us
 Copyright © 2012 LexisNexis, a division of Reed Elsevier Inc. All rights reserved.



UNITED STATES PATENT AND TRADEMARK OFFICE

UNITED STATES DEPARTMENT OF COMMERCE
United States Patent and Trademark Office
Address: COMMISSIONER FOR PATENTS
P.O. Box 1450
Alexandria, Virginia 22313-1450
www.uspto.gov

REEXAM CONTROL NUMBER	FILING OR 371 (c) DATE	PATENT NUMBER
90/012,439	08/17/2012	5796183

22045
BROOKS KUSHMAN P.C.
1000 TOWN CENTER
TWENTY-SECOND FLOOR
SOUTHFIELD, MI 48075

CONFIRMATION NO. 4155
REEXAM ASSIGNMENT NOTICE



Date Mailed: 08/24/2012

NOTICE OF ASSIGNMENT OF REEXAMINATION REQUEST

The above-identified request for reexamination has been assigned to Art Unit 3992. All future correspondence to the proceeding should be identified by the control number listed above and directed to the assigned Art Unit.

A copy of this Notice is being sent to the latest attorney or agent of record in the patent file or to all owners of record. (See 37 CFR 1.33(c)). If the addressee is not, or does not represent, the current owner, he or she is required to forward all communications regarding this proceeding to the current owner(s). An attorney or agent receiving this communication who does not represent the current owner(s) may wish to seek to withdraw pursuant to 37 CFR 1.36 in order to avoid receiving future communications. If the address of the current owner(s) is unknown, this communication should be returned within the request to withdraw pursuant to Section 1.36.

/sdstevenson/

Legal Instruments Examiner
Central Reexamination Unit 571-272-7705; FAX No. 571-273-9900



UNITED STATES PATENT AND TRADEMARK OFFICE

UNITED STATES DEPARTMENT OF COMMERCE
United States Patent and Trademark Office
Address: COMMISSIONER FOR PATENTS
P.O. Box 1450
Alexandria, Virginia 22313-1450
www.uspto.gov

Table with 3 columns: REEXAM CONTROL NUMBER (90/012,439), FILING OR 371 (c) DATE (08/17/2012), PATENT NUMBER (5796183)

22045
BROOKS KUSHMAN P.C.
1000 TOWN CENTER
TWENTY-SECOND FLOOR
SOUTHFIELD, MI 48075

CONFIRMATION NO. 4155
REEXAMINATION REQUEST
NOTICE



Date Mailed: 08/24/2012

NOTICE OF REEXAMINATION REQUEST FILING DATE
(Patent Owner Requester)

Requester is hereby notified that the filing date of the request for reexamination is 08/17/2012, the date the required fee of \$2,520 was received. (See CFR 1.510(d)).

A decision on the request for reexamination will be mailed within three months from the filing date of the request for reexamination. (See 37 CFR 1.515(a)).

Pursuant to 37 CFR 1.33(c), future correspondence in this reexamination proceeding will be with the latest attorney or agent of the record in the patent file.

The paragraphs checked below are part of this communication:

- 1. The party receiving the courtesy copy is the latest attorney or agent of record in the patent file.
2. The person named to receive the correspondence in this proceeding has not been made the latest attorney or agent of record in the patent file because:
A. Requester's claim of ownership of the patent is not verified by the record.
B. The request papers are not signed with a real or apparent binding signature.
C. The mere naming of a correspondence addressee does not result in that person being appointed as the latest attorney or agent of record in the patent file.
3. Addressee is the latest attorney or agent of record in the patent file.
4. Other

/sdstevenson/

Legal Instruments Examiner
Central Reexamination Unit 571-272-7705; FAX No. 571-273-9900

UNITED STATES PATENT AND TRADEMARK OFFICE

UNITED STATES DEPARTMENT OF COMMERCE
 United States Patent and Trademark Office
 Address: COMMISSIONER FOR PATENTS
 P.O. Box 1450
 Alexandria, Virginia 22313-1450
 www.uspto.gov

BROOKS KUSHMAN P.C.
 1000 TOWN CENTER
 TWENTY-SECOND FLOOR
 SOUTHFIELD, MI 48075

Cc: SLATER & MATSIL, L.L.P.
 17950 PRESTON RD, SUITE 1000
 DALLAS, TX 75252-5793

CONTROL NUMBER 90/012439

Date Mailed: 08/24/12

**DENIAL OF REQUEST FOR POWER OF ATTORNEY
 IN A REEXAMINATION PROCEEDING**

The request for Power of Attorney filed 08/17/12 is acknowledged. However, the request cannot be granted at this time for the reason stated below:

- The power of attorney you provided did not comply with 37 CFR 1.32. See 69 Fed. Reg. 29865 (May 26, 2004).
- The revocation is not signed by the applicant, the assignee of the entire interest, or one particular principal attorney having the authority to revoke.
- The power of attorney is from an assignee and the statement required by 37 CFR 3.73(b) has not been received.
- The person signing for the assignee has omitted their empowerment to sign on behalf of the assignee.
- The inventor(s) is/are without authority to appoint attorneys since the assignee has intervened as provided by 37 CFR 3.71.
- The signature(s) of _____, co-inventor(s) in this application, has/have been omitted. The power of attorney will be entered upon receipt of confirmation signed by said co-inventor(s).
- The person(s) appointed in the power of attorney is/are not registered to practice before the U.S. Patent and Trademark Office.

X The correspondence address in the request for power of attorney is different than the address for the patent that is currently of record in the patent file. Pursuant to 37 CFR 1.33, any paper attempting to change the correspondence address in a reexamination proceeding to other than that of record in the patent file is ineffective. See MPEP 2224, 2624. Since the power of attorney will not be separately processed from the change of correspondence address, the power of attorney is ineffective. The correspondence address in the reexamination proceeding is the address of record in the patent file as listed at the top of this letter.

Note: to properly change the correspondence address in the reexamination proceeding, a change of correspondence address must first (or concurrently) be filed in the patent file, for example, through form



UNITED STATES PATENT AND TRADEMARK OFFICE

UNITED STATES DEPARTMENT OF COMMERCE
United States Patent and Trademark Office
Address: COMMISSIONER FOR PATENTS
P.O. Box 1450
Alexandria, Virginia 22313-1450
www.uspto.gov

PTO/SB/123. Note that patent owner may designate a separate address solely for payment of maintenance fees through form PTO/SB/47.

Questions relating to this Notice should be directed to the Central Reexamination Unit at (571) 272-7705.

Patent Assignment Abstract of Title

Total Assignments: 5

Application #: <u>08601268</u>	Filing Dt: 01/31/1996	Patent #: <u>5296183</u>
PCT #: NONE		Publication #: NONE
Inventors: JOHN M. WASHELESKI, STEPHEN R. W. COOPER, BYRON HOURMAND		Issue Dt: 08/18/1998
Title: CAPACITIVE RESPONSIVE ELECTRONIC SWITCHING CIRCUIT		Pub Dt:

Assignment: 1

Reel/Frame: <u>008254 / 0496</u>	Received: 02/10/1997	Recorded: 01/31/1996	Mailed: 02/12/1997	Pages: 2
Conveyance: ASSIGNMENT OF ASSIGNORS INTEREST (SEE DOCUMENT FOR DETAILS).				
Assignor: <u>HOURMAND, BYRON</u>			Exec Dt: 01/31/1996	
Assignee: <u>HARTRON CORPORATION</u>				
5000 NORTH U.S. 131 REED CITY, MICHIGAN 49677				
Correspondent: PRICE, HENEVELD, COOPER, DEWITT & LITTON TERRY S. CALLAGHAN, ESQ. P.O. BOX 2567 GRAND RAPIDS, MI 49501				

Assignment: 2

Reel/Frame: <u>008443 / 0749</u>	Received: 04/17/1997	Recorded: 02/04/1997	Mailed: 05/28/1997	Pages: 2
Conveyance: ASSIGNMENT OF ASSIGNORS INTEREST (SEE DOCUMENT FOR DETAILS).				
Assignor: <u>HOURMAND, BYRON</u>			Exec Dt: 01/31/1996	
Assignee: <u>HARTRON CORPORATION</u>				
5000 NORTH US 131 REED CITY, MICHIGAN 49677				
Correspondent: PRICE, HENEVELD, COOPER, ET AL TERRY S. CALLAGHAN, ESQ. P.O. BOX 2567 GRAND RAPIDS, MI 49501				

Assignment: 3

Reel/Frame: <u>022679 / 0803</u>	Received: 12/22/2009	Recorded: 12/22/2009	Mailed: 12/23/2009	Pages: 11
Conveyance: ASSIGNMENT OF ASSIGNORS INTEREST (SEE DOCUMENT FOR DETAILS).				
Assignor: <u>HARTRON CORPORATION</u>			Exec Dt: 12/17/2009	
Assignee: <u>WVSI, LLC</u>				
5000 NORTH US HIGHWAY 131 REED CITY, MICHIGAN 49677				
Correspondent: TAROLLI, SUNDHEIM, COVELL & TUMMINO LLP 1300 EAST NINTH STREET SUITE 1700 CLEVELAND, OH 44114				

Assignment: 4

Reel/Frame: <u>028804 / 0075</u>	Received: 08/17/2012	Recorded: 08/17/2012	Mailed: 08/20/2012	Pages: 2
Conveyance: ASSIGNMENT OF ASSIGNORS INTEREST (SEE DOCUMENT FOR DETAILS).				
Assignor: <u>WASHELESKI, JOHN M.</u>			Exec Dt: 04/14/2010	
Assignee: <u>HARTRON CORPORATION</u>				
5000 NORTH US-131 REED CITY, MICHIGAN 49677				
Correspondent: SLATER & MATSIL, L.L.P. 17950 PRESTON RD. SUITE 1000 DALLAS, TX 75252				

Assignment: 5

Reel/Frame: <u>025804 / 0137</u>	Received: 08/17/2012	Recorded: 08/17/2012	Mailed: 08/20/2012	Pages: 2
Conveyance: ASSIGNMENT OF ASSIGNORS INTEREST (SEE DOCUMENT FOR DETAILS).				
Assignor: <u>COOPER, STEPHEN R. W.</u>			Exec Dt: 04/14/2010	
Assignee: <u>HARTRON CORPORATION</u>				
5000 NORTH US-131 REED CITY, MICHIGAN 49677				
Correspondent: SLATER & MATSIL, L.L.P. 17950 PRESTON RD. SUITE 1000 DALLAS, TX 75252				

Search Results as of: 08/23/2012 12:12 PM

Additional documents in the chain:

4. From: Stephen R.W. Cooper To: Nartron Corporation

The document was recorded in the United States Patent and Trademark Office at
Reel _____, Frame _____, **or for which a copy thereof is attached.**

5. From: Nartron Corporation To: : UUSI, LLC

The document was recorded in the United States Patent and Trademark Office at
Reel 023679, Frame 0803, or for which a copy thereof is attached.

Under the Paperwork Reduction Act of 1995, no persons are required to respond to a collection of information unless it displays a valid OMB control number.

POWER OF ATTORNEY TO PROSECUTE APPLICATIONS BEFORE THE USPTO

I hereby revoke all previous powers of attorney given in the application identified in the attached statement under 37 CFR 3.73(b).

I hereby appoint:

Practitioners associated with the Customer Number: 25962

OR

Practitioner(s) named below (if more than ten patent practitioners are to be named, then a customer number must be used):

Name	Registration Number	Name	Registration Number

as attorney(s) or agent(s) to represent the undersigned before the United States Patent and Trademark Office (USPTO) in connection with any and all patent applications assigned only to the undersigned according to the USPTO assignment records or assignment documents attached to this form in accordance with 37 CFR 3.73(b).

Please change the correspondence address for the application identified in the attached statement under 37 CFR 3.73(b) to:

The address associated with Customer Number: 25962

OR

<input type="checkbox"/> Firm or Individual Name			
Address			
City	State	Zip	
Country			
Telephone	Email		

Assignee Name and Address:

UUSI, LLC
 5000 North US 131
 Reed City, MI 49677

A copy of this form, together with a statement under 37 CFR 3.73(b) (Form PTO/SB/96 or equivalent) is required to be filed in each application in which this form is used. The statement under 37 CFR 3.73(b) may be completed by one of the practitioners appointed in this form if the appointed practitioner is authorized to act on behalf of the assignee, and must identify the application in which this Power of Attorney is to be filed.

SIGNATURE of Assignee of Record

The individual whose signature and title is supplied below is authorized to act on behalf of the assignee

Signature	<i>Heather Huber</i>	Date	8/17/12
Name	Heather Huber	Telephone	231-832-5513
Title	Admin. Supv.		

This collection of information is required by 37 CFR 1.31, 1.32 and 1.33. The information is required to obtain or retain a benefit by the public which is to file (and by the USPTO to process) an application. Confidentiality is governed by 35 U.S.C. 122 and 37 CFR 1.11 and 1.14. This collection is estimated to take 3 minutes to complete, including gathering, preparing, and submitting the completed application form to the USPTO. Time will vary depending upon the individual case. Any comments on the amount of time you require to complete this form and/or suggestions for reducing this burden, should be sent to the Chief Information Officer, U.S. Patent and Trademark Office, U.S. Department of Commerce, P.O. Box 1450, Alexandria, VA 22313-1450. DO NOT SEND FEES OR COMPLETED FORMS TO THIS ADDRESS. SEND TO: Commissioner for Patents, P.O. Box 1450, Alexandria, VA 22313-1450.

If you need assistance in completing the form, call 1-800-PTO-9199 and select option 2.

ASSIGNMENT

For good and valuable consideration, receipt of which is hereby acknowledged, **Stephen R. W. Cooper** of 5499 N. Hogback Road, Fowlerville, Michigan 48835, hereby assigns to **Nartron Corporation**, a corporation organized and existing under the laws of the state of Michigan, and having a place of business at 5000 North US-131, Reed City, Michigan 49677, its successors, assigns or other legal representatives, the entire right, title and interest, domestic and foreign, in and to the inventions and discoveries in

CAPACITIVE RESPONSIVE ELECTRONIC SWITCHING CIRCUIT

of United States Patent No. 5,796,183, issued August 18, 1998, including all rights of priority, in and to said inventions and discoveries in all countries, including all applications claiming benefit of the filing date hereof, continuations, continuations-in-part, divisionals, reexaminations and reissue applications. This assignment further includes the right to recover for past infringements of United States Patent No. 5,796,183, including bringing actions in the name of Nartron Corporation.

Date: April 14, 2010

Stephen R. W. Cooper
STEPHEN R. W. COOPER

STATE OF Michigan)
) ss.
COUNTY OF Osceola)

On this 14th day of April, 2010, personally appeared before me Stephen R. W. Cooper, to me known to be the person named in and who executed the above instrument, and acknowledged that he executed the same for the uses and purposes therein mentioned.

H. Huber
Notary Public

(SEAL)

My Commission expires:

H. HUBER
NOTARY PUBLIC, STATE OF MI
COUNTY OF OSCEOLA
MY COMMISSION EXPIRES Nov 11, 2013
ACTING IN COUNTY OF Osceola

Exhibit I

Doc Code: IDS

Document Description: Information Disclosure Statement filed

PTO/SB/42 (07-09)
Approved for use through 07/31/2012. OMB 0651-0031

U.S. Patent and Trademark Office; U. S. DEPARTMENT OF COMMERCE

Under the Paperwork Reduction Act of 1995, no persons are required to respond to a collection of information unless it displays a valid OMB control number.

37 CFR 1.501 INFORMATION DISCLOSURE CITATION IN A PATENT (Sheet <u>1</u> of <u>1</u>)				Docket Number (Optional)		Patent Number			
				5796183RX		5,796,183			
				Applicant				Hourmand	
				Issue Date		Art Unit		August 18, 1998	
U.S. PATENT DOCUMENTS									
EXAMINER INITIAL	DOCUMENT NUMBER	DATE	NAME	CLASS	SUBCLASS	FILING DATE IF APPROPRIATE			
	4,766,368	8-23-1988	Cox			9-30-1986			
	4,806,709	2-21-1989	Evans			5-26-1987			
	4,893,071	1-09-1990	Miller			5-24-1988			
	5,113,041	5-12-1992	Blonder et al.			12-28-1990			
	5,337,353	8-09-1994	Boie et al.			4-01-1992			
	5,463,388	10-31-1995	Boie et al.			1-29-1993			
FOREIGN PATENT DOCUMENTS									
	DOCUMENT NUMBER	DATE	COUNTRY	CLASS	SUBCLASS	TRANSLATION			
						YES	NO		
OTHER DOCUMENTS (Including Author, Title, Date, Pertinent Pages, Etc.)									
EXAMINER				DATE CONSIDERED					

This collection of information is required by 37 CFR 1.501. The information is required to obtain or retain a benefit by the public which is to file (and by the USPTO to process) an application. Confidentiality is governed by 35 U.S.C. 122 and 37 CFR 1.14. This collection is estimated to take 2 hours to complete, including gathering, preparing, and submitting the completed application form to the USPTO. Time will vary depending upon the individual case. Any comments on the amount of time you require to complete this form and/or suggestions for reducing this burden, should be sent to the Chief Information Officer, U.S. Patent and Trademark Office, U.S. Department of Commerce, P.O. Box 1450, Alexandria, VA 22313-1450. DO NOT SEND FEES OR COMPLETED FORMS TO THIS ADDRESS. **SEND TO: Commissioner for Patents, P.O. Box 1450, Alexandria, VA 22313-1450.**

If you need assistance in completing the form, call 1-800-PTO-9199 and select option 2.

Electronic Patent Application Fee Transmittal

Application Number:					
Filing Date:					
Title of Invention:	Capacitive Responsive Electronic Switching Circuit				
First Named Inventor/Applicant Name:	Byron Hourmand				
Filer:	Brian A. Carlson/Michelle Hatcher				
Attorney Docket Number:	5796183RX				
Filed as Large Entity					
ex parte reexam Filing Fees					
Description	Fee Code	Quantity	Amount	Sub-Total in USD(\$)	
Basic Filing:					
Request for ex parte reexamination	1812	1	2520	2520	
Pages:					
Claims:					
Miscellaneous-Filing:					
Petition:					
Patent-Appeals-and-Interference:					
Post-Allowance-and-Post-Issuance:					
Extension-of-Time:					

Description	Fee Code	Quantity	Amount	Sub-Total in USD(\$)
Miscellaneous:				
Total in USD (\$)				2520

Electronic Acknowledgement Receipt

EFS ID:	13525604
Application Number:	90012439
International Application Number:	
Confirmation Number:	4155
Title of Invention:	Capacitive Responsive Electronic Switching Circuit
First Named Inventor/Applicant Name:	Byron Hourmand
Customer Number:	25962
Filer:	Brian A. Carlson/Michelle Hatcher
Filer Authorized By:	Brian A. Carlson
Attorney Docket Number:	5796183RX
Receipt Date:	17-AUG-2012
Filing Date:	
Time Stamp:	15:48:59
Application Type:	Reexam (Patent Owner)

Payment information:

Submitted with Payment	yes
Payment Type	Deposit Account
Payment was successfully received in RAM	\$2520
RAM confirmation Number	2388
Deposit Account	501065
Authorized User	

The Director of the USPTO is hereby authorized to charge indicated fees and credit any overpayment as follows:

- Charge any Additional Fees required under 37 C.F.R. Section 1.16 (National application filing, search, and examination fees)
- Charge any Additional Fees required under 37 C.F.R. Section 1.17 (Patent application and reexamination processing fees)

File Listing:					
Document Number	Document Description	File Name	File Size(Bytes)/ Message Digest	Multi Part /.zip	Pages (if appl.)
1	Receipt of Original Ex Parte Reexam Request	5796183RX_ExParteReexamRequestTransmittalForm.pdf	39393 ccc20a86f3ab7de5856aa3190d5ccf2716d45627	no	2
Warnings:					
Information:					
2	Receipt of Original Ex Parte Reexam Request	5796183RX_ExParteReexamRequest.pdf	208597 9f8d86099ada3258c71a406c2391e47a2647f5b9	no	18
Warnings:					
Information:					
3	Reexam Miscellaneous Incoming Letter	5796183_ExhibitA.pdf	5594531 9ae5200d97de4c4288cfc3ac9396b03fd643e13	no	34
Warnings:					
Information:					
4	Reexam Miscellaneous Incoming Letter	5796183_ExhibitB.pdf	5903270 8773b184f19ec186b8d4ff74550d24f14787c7ee	no	54
Warnings:					
Information:					
5	Reexam Miscellaneous Incoming Letter	5796183_ExhibitC.pdf	1801216 0f42ade02d5c9d0a026af0268165041da3a5957d	no	13
Warnings:					
Information:					
6		5796183RX_ExParteReexamStatementUnder37_3b.pdf	218057 6441dc92f6066e561398cb798727a6c87eaa0d7	yes	5
	Multipart Description/PDF files in .zip description				
	Document Description	Start	End		
	Assignee showing of ownership per 37 CFR 3.73(b).	1	1		
	Power of Attorney	2	2		
	Assignee showing of ownership per 37 CFR 3.73(b).	3	5		
Warnings:					
Information:					
7	Information Disclosure Statement (IDS) Form (SB08)	5796183RX_ExParteReexamIDS.pdf	149472 5d1a81386eccc4d3fd84baac8be6591924a09f	no	1

Warnings:					
Information:					
This is not an USPTO supplied IDS fillable form					
8	Fee Worksheet (SB06)	fee-info.pdf	29750	no	2
			4599c3a102663605f3ff04c289e02a31039d01632		
Warnings:					
Information:					
			Total Files Size (in bytes):	13944286	
<p>This Acknowledgement Receipt evidences receipt on the noted date by the USPTO of the indicated documents, characterized by the applicant, and including page counts, where applicable. It serves as evidence of receipt similar to a Post Card, as described in MPEP 503.</p> <p><u>New Applications Under 35 U.S.C. 111</u> If a new application is being filed and the application includes the necessary components for a filing date (see 37 CFR 1.53(b)-(d) and MPEP 506), a Filing Receipt (37 CFR 1.54) will be issued in due course and the date shown on this Acknowledgement Receipt will establish the filing date of the application.</p> <p><u>National Stage of an International Application under 35 U.S.C. 371</u> If a timely submission to enter the national stage of an international application is compliant with the conditions of 35 U.S.C. 371 and other applicable requirements a Form PCT/DO/EO/903 indicating acceptance of the application as a national stage submission under 35 U.S.C. 371 will be issued in addition to the Filing Receipt, in due course.</p> <p><u>New International Application Filed with the USPTO as a Receiving Office</u> If a new international application is being filed and the international application includes the necessary components for an international filing date (see PCT Article 11 and MPEP 1810), a Notification of the International Application Number and of the International Filing Date (Form PCT/RO/105) will be issued in due course, subject to prescriptions concerning national security, and the date shown on this Acknowledgement Receipt will establish the international filing date of the application.</p>					

Under the Paperwork Reduction Act of 1995, no persons are required to respond to a collection of information unless it displays a valid OMB control number.

(Also referred to as FORM PTO - 1465)

REQUEST FOR *EX PARTE* REEXAMINATION TRANSMITTAL FORM

Address to:

**Mail Stop *Ex Parte* Reexam
Commissioner for Patents
P.O. Box 1450
Alexandria, VA 22313-1450**

Attorney Docket No. 5796183RX

Date:

1. This is a request for *ex parte* reexamination pursuant to 37 CFR 1.510 of patent number 5,796,183 issued August 18, 1998. The request is made by:
 patent owner. third party requester.
2. The name and address of the person requesting reexamination is:
UUSI, LLC
5000 North US Highway 131, Twenty-Second Floor
Reed City, Michigan 49677
3. a. A check in the amount of \$_____ is enclosed to cover the reexamination fee, 37 CFR 1.20(c)(1);
 b. The Director is hereby authorized to charge the fee as set forth in 37 CFR 1.20(c)(1) to Deposit Account No. 50-1065; or
 c. Payment by credit card. Form PTO-2038 is attached.
4. Any refund should be made by check or credit to Deposit Account No. 50-1065. 37 CFR 1.26(c). If payment is made by credit card, refund must be to credit card account.
5. A copy of the patent to be reexamined having a double column format on one side of a separate paper is enclosed. 37 CFR 1.510(b)(4)
6. CD-ROM or CD-R in duplicate, Computer Program (Appendix) or large table
 Landscape Table on CD
7. Nucleotide and/or Amino Acid Sequence Submission
If applicable, items a. - c. are required.
 - a. Computer Readable Form (CRF)
 - b. Specification Sequence Listing on:
 - i. CD-ROM (2 copies) or CD-R (2 copies); or
 - ii. paper
 - c. Statements verifying identity of above copies
8. A copy of any disclaimer, certificate of correction or reexamination certificate issued in the patent is included.
9. Reexamination of claim(s) 18 and 27 is requested.
10. A copy of every patent or printed publication relied upon is submitted herewith including a listing thereof on Form PTO/SB/08, PTO-1449, or equivalent.
11. An English language translation of all necessary and pertinent non-English language patents and/or printed publications is included.

[Page 1 of 2]

This collection of information is required by 37 CFR 1.510. The information is required to obtain or retain a benefit by the public which is to file (and by the USPTO to process) an application. Confidentiality is governed by 35 U.S.C. 122 and 37 CFR 1.11 and 1.14. This collection is estimated to take 2 hours to complete, including gathering, preparing, and submitting the completed application form to the USPTO. Time will vary depending upon the individual case. Any comments on the amount of time you require to complete this form and/or suggestions for reducing this burden, should be sent to the Chief Information Officer, U.S. Patent and Trademark Office, U.S. Department of Commerce P.O. Box 1450, Alexandria, VA 22313-1450. DO NOT SEND FEES OR COMPLETED FORMS TO THIS ADDRESS. **SEND TO: Mail Stop *Ex Parte* Reexam, Commissioner for Patents, P.O. Box 1450, Alexandria, VA 22313-1450.**
If you need assistance in completing the form, call 1-800-PTO-9199 and select option 2.

Under the Paperwork Reduction Act of 1995, no persons are required to a collection of information unless it displays a valid OMB control number.

12. The attached detailed request includes at least the following items:

- a. A statement identifying each substantial new question of patentability based on prior patents and printed publications. 37 CFR 1.510(b)(1)
- b. An identification of every claim for which reexamination is requested, and a detailed explanation of the pertinency and manner of applying the cited art to every claim for which reexamination is requested. 37 CFR 1.510(b)(2)

13. A proposed amendment is included (only where the patent owner is the requester). 37 CFR 1.510(e)

14. a. It is certified that a copy of this request (if filed by other than the patent owner) has been served in its entirety on the patent owner as provided in 37 CFR 1.33(c).
 The name and address of the party served and the date of service are:

Date of Service: _____; or

b. A duplicate copy is enclosed since service on patent owner was not possible.

15. Correspondence Address: Direct all communication about the reexamination to:

The address associated with Customer Number: 25962

OR

Firm or Individual Name

Address

City	State	Zip
Country		
Telephone	Email	

16. The patent is currently the subject of the following concurrent proceeding(s):

- a. Copending reissue Application No. _____.
- b. Copending reexamination Control No. _____.
- c. Copending Interference No. _____.
- d. Copending litigation styled: _____

WARNING: Information on this form may become public. Credit card information should not be included on this form. Provide credit card information and authorization on PTO-2038.

_____/Brian A. Carlson/_____
 Authorized Signature

August 17, 2012
 Date

Brian A. Carlson
 Typed/Printed Name

For Patent Owner Requester

37,793
 Registration No. For Third Party Requester

IN THE UNITED STATES PATENT AND TRADEMARK OFFICE

U.S. Patent No.:	5,796,183 B1	§	Docket No.:	5796183RX
Issued:	August 18, 1998	§	Inventors:	Hourmand et al.
Filed:	January 31, 1996	§	Patent Owner:	UUSI, LLC
Control No.	TBD	§	Examiner:	TBD

For: Capacitive Responsive Electronic Switching Circuit

Mail Stop *Ex Parte* Reexam
Attn: Central Reexamination Unit
Commissioner for Patents
P.O. Box 1450
Alexandria, VA 22313-1450

REQUEST FOR *EX PARTE* REEXAMINATION UNDER 35 U.S.C. §§ 302-307

Dear Sir:

Patent Owner UUSI, LLC respectfully requests *Ex Parte* Reexamination, pursuant to the provisions of 35 U.S.C. §§ 302–307 (2002), of claims 18 and 27 of United States Patent No. 5,796,183 (the “183 Patent”). This patent is still enforceable.

As set forth below, the prior art reference submitted herewith was not previously before the Office, and presents new, non-cumulative technological teachings not considered during the 183 Patent prosecution history.

I. OVERVIEW OF THE `183 PATENT AND ITS PROSECUTION HISTORY

Section II.A below provides an overview of the subject matter of the `183 Patent, while Section II.B provides an overview of its prosecution history.

A. The `183 Patent

The `183 Patent, a copy of which is provided as Exhibit A, issued on August 18, 1998 from an application filed on January 31, 1996. The `183 Patent generally relates to a capacitive responsive electronic switching circuit including an oscillator providing a periodic output signal, an input touch terminal defining an area for an operator to provide an input by proximity and touch, and a detector circuit coupled to the oscillator for receiving the periodic output signal from the oscillator, and coupled to the input touch terminal. *See, e.g.*, `183 Patent, Abstract.

The `183 Patent contains 32 total claims, with claims 1, 9, 12, 16, 18, 20, 24 and 27 being independent. Claims 18 and 27, which are the subject of this reexam request, require an oscillator, a plurality of touch terminals, and a detector circuit.

An embodiment with a single touch terminal is shown in Figure 4, and an embodiment with multiple touch terminals is shown in Figure 11, both of which are reproduced below:

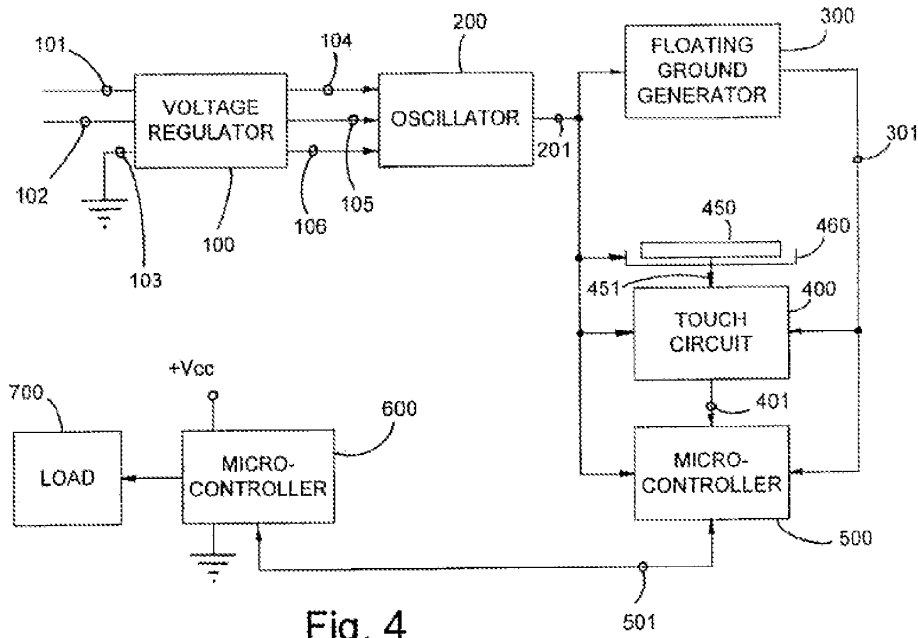

Fig. 4

Fig. 4 of the '183 Patent

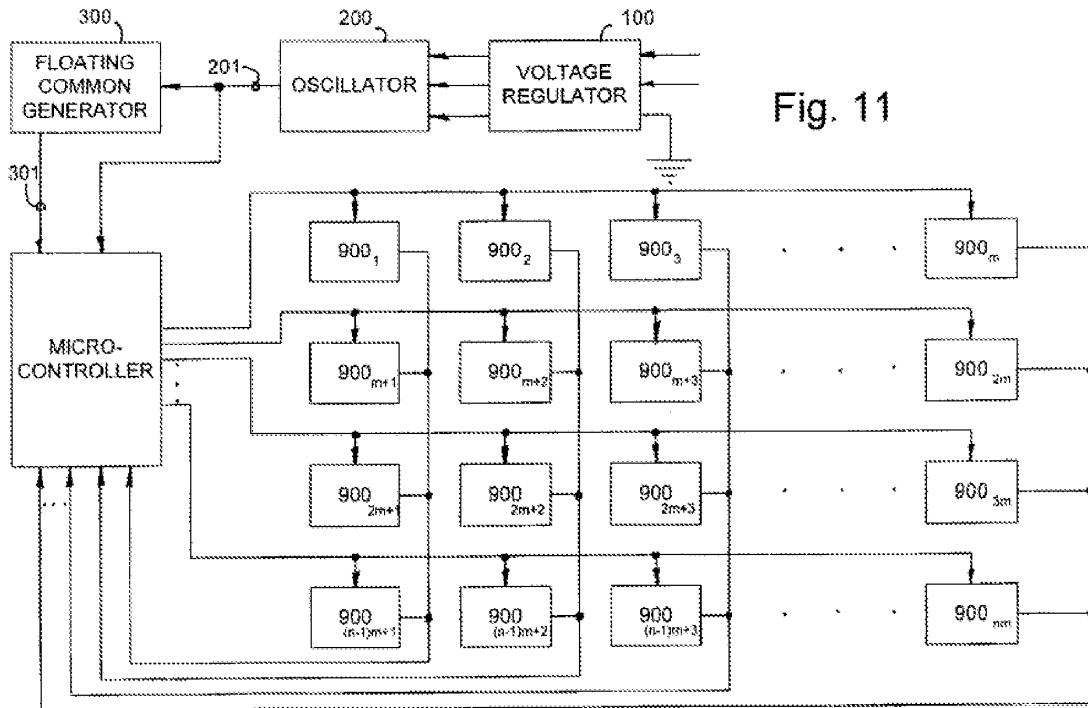

Fig. 11

Fig. 11 of the '183 Patent

The multiple touch pad circuit of Figure 11 is a variation of the embodiment shown in Figure 4, but with an array of touch circuits designated as 900₁ through 900_{nm}. *See, e.g., id.* at col. 18:34-41. The touch detection circuit offers improvements in detection sensitivity that allow close control of the degree of proximity (ideally very close proximity) that is required for actuation and to enable employment of a multiplicity of small sized touch terminals in a physically close array such as a keyboard. *See, e.g., id.* at col. 5:53-57.

Microcontroller 500 selects each row of the touch circuits 900₁ to 900_{nm} by providing the signal from oscillator 200 to selected rows of touch circuits. *See, e.g., id.* at col. 18:43-46. The values of the resistors and capacitors utilized in oscillator 200 may be varied from those disclosed above to provide for different oscillator output frequencies. *See, e.g., id.* at col. 14:22-25. Although the preferred frequency is at or above 100 kHz, and more preferably at or above 800 kHz, it is conceivable that frequencies as low as 50 kHz could be used provided the frequency creates a difference in the impedance paths of adjacent pads that is sufficient enough to accurately distinguish between an intended touch and the touch of an adjacent pad. *See, e.g., id.* at col. 11:19-25.

Microcontroller 500 sequentially activates the touch circuit rows and associates the received inputs from the columns of the array with the activated touch circuit(s). *See, e.g., id.* at col. 46-49. The detector circuit is responsive to signals from the oscillator and the presence of an operator's body capacitance to ground coupled to the touch terminal when in proximity or touched by an operator to provide a control output signal. *See, e.g., id.* at Abstract. Another method for implementing capacitive touch switches relies on the change in capacitive coupling between a touch terminal and ground. *See, e.g., id.* at col. 3:44-46.

B. The Prosecution History of the `183 Patent

A copy of selected portions of the prosecution history of the `183 Patent is provided in Exhibit B.

The `183 Patent issued from U.S. Patent Application Serial No. 08/601,268 (“the `268 application”), filed on January 31, 1996, and naming Byron Hourmand as the sole inventor. The `268 application was filed with 20 total claims, of which four were independent. Claims 21-32 were added by subsequent amendment. A cross-reference between the issued claims and the application claims from which they issued is provided below for convenience.

Issued Claim	Appl. Claim	Issued Claim	Appl. Claim	Issued Claim	Appl. Claim	Issued Claim	Appl. Claim
1	1	9	5	17	16	25	25
2	2	10	6	18	18	26	26
3	3	11	7	19	19	27	27
4	4	12	12	20	20	28	28
5	8	13	13	21	21	29	29
6	9	14	14	22	22	30	30
7	10	15	17	23	23	31	31
8	11	16	15	24	24	32	32

In an Office Action dated April 22, 1997, the Examiner rejected application claims 6, 7 and 16 under 35 U.S.C. § 112, second paragraph, as being indefinite. *See* Ex. B, `183 Patent File History, Office Action, p. 2 (Apr. 22, 1997). Claims 6, 7 and 16 would be allowable if rewritten to overcome the section 112 rejection, and to include all of the limitations of the base claim and any intervening claims. *See id.* at p. 5.

Claims 1-4 and 12-14 were rejected under 35 U.S.C. § 102(b) as being anticipated by U.S. Patent No. 4,352,141 to Kent (“Kent”). *See id.* Claims 8-11, 18, and 19 were rejected under 35 § U.S.C. 103(a) as being unpatentable over Kent in view of U.S. Patent No. 5,087,825 to Ingraham (“Ingraham”), *see id.* at p. 3, and claims 8-11, 18 and 19 were rejected under 35 U.S.C.

§ 103(a) as being unpatentable over Kent in view of U.S. Patent No. 5,235,217 to Kirton (“Kirton”). *See id.* at p. 4. Lastly, claims 5 and 15 were objected to as being dependent upon a rejected base claim, but would be allowable if rewritten in independent form including all the limitations of the base claim and any intervening claims. *See id.* at p. 5.

In response, the Applicant filed an amendment on August 22, 1997, amending claims 1, 3, 5, 6, 12-18 and 20, and adding new claims 21-32. In particular, the Applicant amended independent claim 18 as follows:

18. (Amended) A capacitive responsive electronic switching circuit comprising:
an oscillator providing a periodic output signal having a predefined frequency;
a plurality of input touch terminals defining adjacent areas on a dielectric substrate for an operator to provide inputs by proximity and touch; and
a detector circuit coupled to said oscillator for receiving said periodic output signal from said oscillator, and coupled to said input touch terminals, said detector circuit being responsive to signals from said oscillator and the presence of an operator's body capacitance to ground coupled said touch terminals when proximal or touched by an operator to provide a control output signal,
wherein said predefined frequency of said oscillator is selected to decrease the impedance of said dielectric substrate relative to the impedance of any contaminate that may create an electrical on said dielectric substrate path between said adjacent areas, and wherein said detector circuit compares the sensed body capacitance to ground proximate an input touch terminal to a threshold level to prevent inadvertent generation of the control output signal.

Ex. B, `183 Patent File History, Amendment, p. 11 (Aug. 22, 1997). The Applicant argued that the Kent and Ingraham patents both fail to teach or suggest a capacitive responsive electronic switching circuit comprising a detector circuit that compares the sensed body capacitance proximate an input touch terminal to a threshold level in order to prevent inadvertent generation of a control output signal. *See id.* at p. 19. The Applicant further argued that the Kirton patent, like the Kent and Ingraham patents, does not disclose a touch control circuit that is capable of discriminating between a full intentional touch of a touch terminal and an inadvertent touch of a portion of the surface of the touch terminal. *See id.*

With respect to new independent claim 27, the Applicant argued none of the cited references teaches or suggests a switching circuit for a control device that comprises at least first and second touch terminals and a detector circuit that generates a control output signal for actuation of the control device when an operator is proximal or touches the second touch terminal after the operator is proximal or touches the first touch terminal. *See id.* at pp. 20-21.

The Examiner issued a Notice of Allowance on October 27, 1997, allowing all of the pending claims. *See Ex. B, `183 Patent File History, Notice of Allowance, p. 2 (Oct. 27, 1997).* The Applicant then filed a section 312 amendment on November 3, 1997 to delete the word “said” after the word “when” in claim 27, line 11. *See Ex. B, `183 Patent File History, Amendment Under 37 C.F.R. § 1.312, p. 1 (Nov. 3, 1997).* The issue fee was paid on January 26, 1998, *see Ex. B, `183 Patent File History, Issue Fee Transmittal, p. 1 (Jan. 26, 1998),* and the `183 Patent subsequently issued on August 18, 1998.

The Applicant filed a certificate of correction on January 20, 1999, which was accepted by the patent office on May 11, 1999. In claim 18, the word “path” was inserted after the word “electrical” in column 27, line 44 of the `183 Patent, and the word “path” was deleted from column 27, line 45 of the `183 Patent. *See Ex. B, `183 Patent File History, Cert. of Correction, p. 3 (May 11, 1999).* In claim 27, the word “said” was deleted after the word “when.” *See id.*

The Patent Owner subsequently made several attempts to correct the inventorship of the patent, which resulted in the inventorship being changed to be Byron Hourmand, John M. Washeleski and Stephen R. W. Cooper. *See Ex. B, `183 Patent File History, Petition Decision (Aug. 25, 2011); see also Corrected Filing Receipt, p. 1 (Aug. 25, 2011); Certificate of Correction (Oct. 11, 2011).*

II. SUBSTANTIAL NEW QUESTION (“SNQ”) OF PATENTABILITY

Section III.A below provides a list of the prior art reference relied upon in the present request. Section III.B provides an overview of the prior art reference. Section III.C provides a statement regarding an SNQ of patentability for claims 18 and 27 of the `183 Patent with respect to the new reference.

|

A. Listing of Prior Art Patents and Publications

Reexamination of claims 18 and 27 of the `183 Patent is requested in view of the following reference:

Exhibit C Boie et al., U.S. Patent No. 5,463,388, filed on January 29, 1993 and issued on October 31, 1996 (“Boie `388”), which qualifies as 35 U.S.C. § 102(a)-type prior art.

B. Overview of Prior Art Patents and Publications

As discussed in more detail below, Boie`388 presents new, non-cumulative technological teachings not considered during the `183 Patent prosecution history.

1. Boie `388

Boie `388 generally relates to sensors for capacitively sensing the position or movement of an object, such as a finger, on a surface. *See, e.g.*, Boie `388, col. 1:6-8. A computer input device comprises a thin, insulating surface covering an array of electrodes arranged in a grid pattern and connected in columns and rows. *See, e.g., id.* at Abstract. Each column and row is connected to circuitry for measuring the capacitance seen by each column and row. *See, e.g., id.* The position of an object with respect to the array is determined from the centroid of such capacitance values, which is calculated in a microcontroller. *See, e.g., id.* Figure 4, reproduced below, illustrates a block diagram of a two-dimensional capacitive position sensor.

FIG. 4

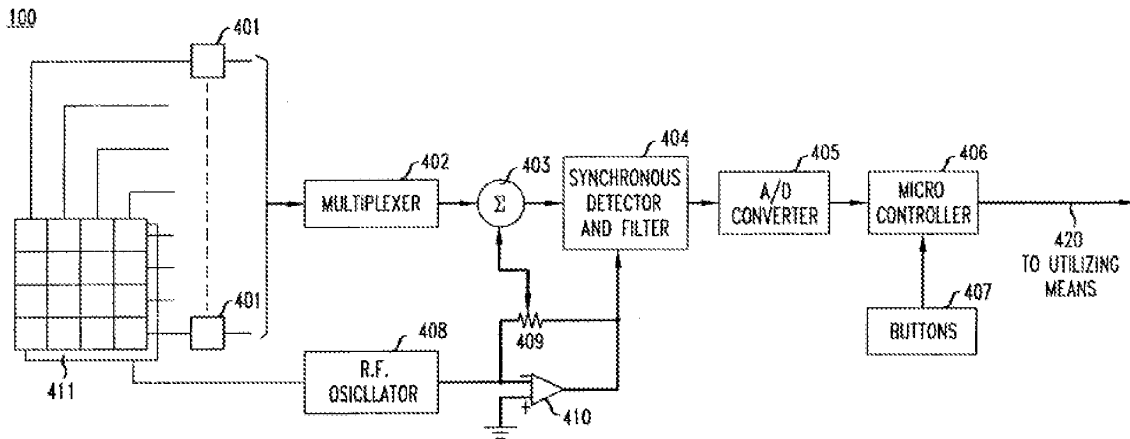

Fig. 4 of Boie `38

Each row and column of electrodes from array 100 is connected to an integrating amplifier and bootstrap circuit 401, each of which can be selected by multiplexer 402 under control of microcontroller 406. *See, e.g., Boie `388, col. 3:56-61.* The selected output is forwarded to summing circuit 403, the output of which is converted by synchronous detector and filter 404 to a signal related to the capacitance of the row or column selected by multiplexer 402. *See, e.g., id. at col. 3:62-67.* RF oscillator 408 provides an RF signal of, for example, 100 kilohertz, to circuits 401, synchronous detector and filter 404 via inverter 410, and guard plane 411, which is a substantially continuous plane parallel to array 100 and associated connections, and serves to isolate array 100 from extraneous signals. *See, e.g., id. at col. 3:67-col. 4:5.*

To measure separate capacitance values for each electrode in array 100 instead of the collective capacitances of subdivided electrode elements connected in rows and columns, a circuit 401 is provided for each electrode in array 100 and multiplexer 402 is enlarged to accommodate the outputs from all circuits 401. *See, e.g., id. at col. 4:14-21.* The output of synchronous detector and filter 404 is converted to digital form by analog-to-digital converter

405 and forwarded to microcontroller 406 so that microcontroller 406 obtains a digital value representing the capacitance seen by any row or column of electrode elements (or electrode if measured separately) selected by multiplexer 402. *See, e.g., id.* at col. 4:22-28.

C. Statement Pointing Out Each SNQ of Patentability

Boie `388 was not cited during the original patent prosecution of the `183 Patent, and presents new, non-cumulative technological teachings with respect to `183 Patent claims 18 and 27.

1. Claim 18

During the original prosecution, the Applicant amended independent claim 18 to recite “wherein said detector circuit compares the sensed body capacitance to ground proximate an input touch terminal to a threshold level to prevent inadvertent generation of the control output signal,” and argued that the cited art did not teach or suggest these limitations. After the Applicant made this amendment, the Examiner allowed claim 18.

Boie `388 discloses,

Referring to FIG. 6, microcomputer 406 reads the initial capacitance values for all the elements in array 100 and stores such values (step 601). Such initial values should reflect the state of array 100 without a finger or other object being nearby, accordingly, it may be desirable to repeat step 601 a number of times and then to select the minimum capacitance values read as the initial values, thereby compensating for the effect of any objects moving close to array 100 during the initialization step. After initialization, all capacitance values are periodically read and the initial values subtracted to yield a remainder value for each element (step 602). If one or more of the remainders exceeds a preset threshold (step 603), indicating that an object is close to or touching array 100, then the x and y coordinates of the centroid of capacitance for such object can be calculated from such remainders (step 604). . . . To avoid spurious operation, it may be desirable to require that two or more measurements exceed the preset threshold. The threshold can be set to some percentage of the range of A/D converter 405, for example 10-15% of such range.

Boie `388, col. 5:10-48; *see also id.* at Fig. 6. Boie `388 thus presents new, non-cumulative technological teachings related to the elements of claim 18 added by amendment, and such teachings were not considered in the cited art during the `183 Patent prosecution history. If the original Examiner had known of Boie `388, the Examiner likely would have considered it relevant, and likely would have cited it during the original prosecution. Boie `388 therefore raises an SNQ of patentability with respect to independent claim 18.

2. Claim 27

During the prosecution of the `183 Patent, the Applicant added independent claim 27, and argued that the cited art did not teach or suggest a detector circuit that generates a control output signal for actuation of the control device when an operator is proximal or touches the second touch terminal after the operator is proximal or touches the first touch terminal. After the Applicant added claim 27 and made this argument, the Examiner allowed claim 27.

Boie `388 discloses,

In using the position sensor of the invention as a computer mouse or trackball to control a cursor, movement of the mouse or trackball is emulated by touching array 100 with finger 102, or some other object, and stroking finger 102 over array 100 to move the cursor. Changes in position of the finger with respect to array 100 are reflected in corresponding changes in position of the cursor. Thus, for such an application, microcontroller 406 sends data over lead 420 relating to changes in position. FIG. 6 is a flow chart of the operation of microcontroller 406 in such an application.

Boie `388, col. 4:67-col. 5:9; *see also id.* at Fig. 6. Boie `388 thus presents new, non-cumulative technological teachings related to the elements of claim 27 argued by the Applicant, and such teachings were not considered in the cited art during the `183 Patent prosecution history. If the original Examiner had known of Boie `388, the Examiner likely would have considered it relevant, and likely would have cited it during the original prosecution. Boie `388 therefore raises an SNQ of patentability with respect to independent claim 27.

III. DETAILED EXPLANATION OF THE RELEVANCY AND MANNER OF APPLYING THE PRIOR ART REFERENCES TO EVERY CLAIM FOR WHICH REEXAMINATION IS REQUESTED

A detailed explanation pointing out the relevance and application of the prior art references to each of claims 18 and 27 is provided below. The charts below indicate what the Patent Owner believes are the portions of the cited art most relevant to the elements of the claims for which reexamination is requested. The Patent Owner, however, reserves the right to take positions asserting and submit arguments explaining why various claim elements are not disclosed or suggested by the cited art.

A. Claim 18

`183 Patent Claim Language	Boie `388
18. A capacitive responsive electronic switching circuit comprising:	“The capacitive sensor of the invention comprises a thin, insulating surface covering a plurality of electrodes. The position of an object, such as a finger or hand-held stylus, with respect to the electrodes, is determined from the centroid of capacitance values measured at the electrodes. . . . The x and y coordinates of the centroid are calculated in a microcontroller from the measured capacitances.” Boie `388, col. 1:61-col. 2:5, Fig. 4.
an oscillator providing a periodic output signal having a predefined frequency;	“RF oscillator 408 provides an RF signal, for example, 100 kilohertz, to circuits 401, synchronous detector and filter 404 via inverter 410, and guard plane 411.” <i>Id.</i> at col. 3:67-col. 4:2, Fig. 4.
a plurality of input touch terminals defining adjacent areas on a dielectric substrate for an operator to provide inputs by proximity and touch; and	“The operational principle of the capacitive position sensor of the invention is shown in FIG. 1. Electrode array 100 is a square or rectangular array of electrodes 101 arranged in a grid pattern of rows and columns, as in an array of tiles. . . . The electrodes are covered with a thin layer of insulating material (not shown). . . . Histogram 110 shows the capacitances for electrodes 101 in array 100 with respect to finger 102.” <i>Id.</i> at col.

`183 Patent Claim Language	Boie `388
	<p>2:49-62, Fig. 1.</p> <p>“FIG. 2 shows four such subdivided electrodes in more detail at an intersection of two rows and two columns in array 100. As can be seen from FIG. 2, a horizontal element 201 and a vertical element 202 are situated at each intersection of a row and column.” <i>Id.</i> at col. 3:16-20, Fig. 2.</p> <p>“As will be clear to those skilled in the art, elements 201 and 202 can be fabricated in one plane of a multi-layer printed circuit board together with one set of interconnections, for example, the horizontal row connections 203. The vertical row connections 204 can then be fabricated in another plane of the circuit board with appropriate via connections between the planes.” <i>Id.</i> at col. 3:30-36, Fig. 2.</p>
<p>a detector circuit coupled to said oscillator for receiving said periodic output signal from said oscillator, and coupled to said input touch terminals, said detector circuit being responsive to signals from said oscillator and the presence of an operator's body capacitance to ground coupled said touch terminals when proximal or touched by an operator to provide a control output signal,</p>	<p>“[E]ach row and column of electrodes from array 100 is connected to an integrating amplifier and bootstrap circuit 401, . . . Each of the outputs from circuits 401 can be selected by multiplexer 402 under control of microcontroller 406. The selected output is then forwarded to summing circuit 403, where such output is combined with a signal from trimmer resistor 409. Synchronous detector and filter 404 convert the output from summing circuit 403 to a signal related to the capacitance of the row or column selected by multiplexer 402. RF oscillator 408 provides an RF signal, for example, 100 kilohertz, to circuits 401, synchronous detector and filter 404 via inverter 410, and guard plane 411.” <i>Id.</i> at col. 3:53-col. 4:2, Fig. 4.</p> <p>“The output of synchronous detector and filter 404 is converted to digital form by analog-to-digital converter 405 and forwarded to microcontroller 406. Thus, microcontroller 406 can obtain a digital value representing the capacitance seen by any row or column of electrode elements (or electrode if measured</p>

`183 Patent Claim Language	Boie `388
	<p>separately) selected by multiplexer 402. . . . Microcontroller 406 sends data to utilizing means, such as a personal computer (not shown) over lead 420.” <i>Id.</i> at col. 4:21-32, Fig. 4.</p>
<p>wherein said predefined frequency of said oscillator is selected to decrease the impedance of said dielectric substrate relative to the impedance of any contaminate that may create an electrical path on said dielectric substrate between said adjacent areas, and</p> <p>wherein said detector circuit compares the sensed body capacitance to ground proximate an input touch terminal to a threshold level to prevent inadvertent generation of the control output signal.</p>	<p>“RF oscillator 408 provides an RF signal, for example, 100 kilohertz, to circuits 401, synchronous detector and filter 404 via inverter 410, and guard plane 411.” <i>Id.</i> at col. 3:67-col. 4:2, Fig. 4.</p> <p>“The effects of electrode-to-electrode capacitances, wiring capacitances and other extraneous capacitances are minimized by driving all electrodes and guard plane 411 in unison with the same RF signal from RF oscillator 408.” <i>Id.</i> at col. 4:58-61.</p> <p>“Referring to FIG. 6, microcomputer 406 reads the initial capacitance values for all the elements in array 100 and stores such values (step 601). Such initial values should reflect the state of array 100 without a finger or other object being nearby, accordingly, it may be desirable to repeat step 601 a number of times and then to select the minimum capacitance values read as the initial values, thereby compensating for the effect of any objects moving close to array 100 during the initialization step. After initialization, all capacitance values are periodically read and the initial values subtracted to yield a remainder value for each element (step 602). If one or more of the remainders exceeds a preset threshold (step 603), indicating that an object is close to or touching array 100, then the x and y coordinates of the centroid of capacitance for such object can be calculated from such remainders (step 604). . . . To avoid spurious operation, it may be desirable to require that two or more measurements exceed the preset threshold. The threshold can be set to some percentage of the range of A/D converter 405, for example 10-15% of such range.” <i>Id.</i> at col. 5:10-48, Fig. 6.</p>

B. Claim 27

`183 Patent Claim Language	Boie `388
<p>27. A capacitive responsive electronic switching circuit for a controlled device comprising:</p>	<p>“The capacitive sensor of the invention comprises a thin, insulating surface covering a plurality of electrodes. The position of an object, such as a finger or hand-held stylus, with respect to the electrodes, is determined from the centroid of capacitance values measured at the electrodes. . . . The x and y coordinates of the centroid are calculated in a microcontroller from the measured capacitances.” Boie `388, col. 1:61-col. 2:5, Fig. 4.</p> <p>“A computer input device for use as a computer mouse or keyboard comprises a thin, insulating surface covering an array of electrodes. . . . For applications in which the input device is used as a mouse, the microcontroller forwards position change information to the computer. For applications in which the input device is used as a keyboard, the microcomputer identifies a key from the position of the touching object and forwards such key identity to the computer.” <i>Id.</i> at Abstract.</p>
<p>an oscillator providing a periodic output signal having a predefined frequency;</p>	<p>“RF oscillator 408 provides an RF signal, for example, 100 kilohertz, to circuits 401, synchronous detector and filter 404 via inverter 410, and guard plane 411.” <i>Id.</i> at col. 3:67-col. 4:2, Fig. 4.</p>
<p>first and second touch terminals defining areas for an operator to provide an input by proximity and touch; and</p>	<p>“The operational principle of the capacitive position sensor of the invention is shown in FIG. 1. Electrode array 100 is a square or rectangular array of electrodes 101 arranged in a grid pattern of rows and columns, as in an array of tiles. . . . The electrodes are covered with a thin layer of insulating material (not shown). . . . Histogram 110 shows the capacitances for electrodes 101 in array 100 with respect to finger 102.” <i>Id.</i> at col. 2:49-62, Fig. 1.</p> <p>“FIG. 2 shows four such subdivided electrodes in more detail at an intersection of two rows and</p>

`183 Patent Claim Language	Boie `388
	<p>two columns in array 100. As can be seen from FIG. 2, a horizontal element 201 and a vertical element 202 are situated at each intersection of a row and column.” <i>Id.</i> at col. 3:16-20, Fig. 2.</p> <p>“As will be clear to those skilled in the art, elements 201 and 202 can be fabricated in one plane of a multi-layer printed circuit board together with one set of interconnections, for example, the horizontal row connections 203. The vertical row connections 204 can then be fabricated in another plane of the circuit board with appropriate via connections between the planes.” <i>Id.</i> at col. 3:30-36, Fig. 2.</p>
<p>a detector circuit coupled to said oscillator for receiving said periodic output signal from said oscillator, and coupled to said first and second touch terminals, said detector circuit being responsive to signals from said oscillator and the presence of an operator's body capacitance to ground coupled to said first and second touch terminals when proximal or touched by an operator to provide a control output signal for actuation of the controlled device,</p>	<p>“[E]ach row and column of electrodes from array 100 is connected to an integrating amplifier and bootstrap circuit 401, . . . Each of the outputs from circuits 401 can be selected by multiplexer 402 under control of microcontroller 406. The selected output is then forwarded to summing circuit 403, where such output is combined with a signal from trimmer resistor 409. Synchronous detector and filter 404 convert the output from summing circuit 403 to a signal related to the capacitance of the row or column selected by multiplexer 402. RF oscillator 408 provides an RF signal, for example, 100 kilohertz, to circuits 401, synchronous detector and filter 404 via inverter 410, and guard plane 411.” <i>Id.</i> at col. 3:53-col. 4:2, Fig. 4.</p> <p>“The output of synchronous detector and filter 404 is converted to digital form by analog-to-digital converter 405 and forwarded to microcontroller 406. Thus, microcontroller 406 can obtain a digital value representing the capacitance seen by any row or column of electrode elements (or electrode if measured separately) selected by multiplexer 402. . . . Microcontroller 406 sends data to utilizing means, such as a personal computer (not shown) over lead 420.” <i>Id.</i> at col. 4:21-32, Fig. 4.</p>

`183 Patent Claim Language	Boie `388
<p>said detector circuit being configured to generate said control output signal when an operator is proximal or touches said second touch terminal after the operator is proximal or touches said first touch terminal.</p>	<p>“A computer input device for use as a computer mouse or keyboard comprises a thin, insulating surface covering an array of electrodes. . . . For applications in which the input device is used as a mouse, the microcontroller forwards position change information to the computer. For applications in which the input device is used as a keyboard, the microcomputer identifies a key from the position of the touching object and forwards such key identity to the computer.” <i>Id.</i> at Abstract.</p> <p>“In using the position sensor of the invention as a computer mouse or trackball to control a cursor, movement of the mouse or trackball is emulated by touching array 100 with finger 102, or some other object, and stroking finger 102 over array 100 to move the cursor. Changes in position of the finger with respect to array 100 are reflected in corresponding changes in position of the cursor. Thus, for such an application, microcontroller 406 sends data over lead 420 relating to changes in position. FIG. 6 is a flow chart of the operation of microcontroller 406 in such an application.” <i>Id.</i> at col. 4:67-col. 5:9, Fig. 6.</p>

IV. CONCLUSION

A substantial new question of patentability is raised based on the newly cited prior art, and therefore a reexamination of claims 18 and 27 is warranted. Again, the Patent Owner reserves the right to take positions asserting and submit arguments explaining why various claim elements are not disclosed or suggested by the cited art.

If the Office should have any questions, please contact the undersigned attorney. The Commissioner is hereby authorized to charge any fees due in connection with this filing, or credit any overpayment, to Deposit Account No. 50-1065.

Respectfully submitted,

August 17, 2012
Date

/Brian A. Carlson/
Brian A. Carlson
Reg. No. 37,793

Slater & Matsil, L.L.P.
17950 Preston Rd.
Suite 1000
Dallas, TX 75252
972-732-1001
972-732-9218 (fax)

EXHIBIT A

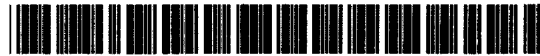

US005796183A

United States Patent [19]
Hourmand

[11] **Patent Number:** **5,796,183**
[45] **Date of Patent:** **Aug. 18, 1998**

- [54] **CAPACITIVE RESPONSIVE ELECTRONIC SWITCHING CIRCUIT**
- [75] **Inventor:** **Byron Hourmand**, Hersey, Mich.
- [73] **Assignee:** **Nartron Corporation**, Reed City, Mich.
- [21] **Appl. No.:** **601,268**
- [22] **Filed:** **Jan. 31, 1996**
- [51] **Int. Cl.⁶** **H01H 35/00**
- [52] **U.S. Cl.** **307/116; 361/181; 307/125; 307/139**
- [58] **Field of Search** **307/112, 113, 307/116, 125, 139, 140, 157; 361/181**
- [56] **References Cited**

U.S. PATENT DOCUMENTS

- 3,549,909 12/1970 Adelson et al. .
- 3,641,410 2/1972 Vogelsberg .
- 3,651,391 3/1972 Vogelsberg .
- 3,666,988 5/1972 Bellis .
- 3,798,370 3/1974 Hurst .
- 3,879,618 4/1975 Larson 307/116
- 3,899,713 8/1975 Barkan et al. .
- 3,911,215 10/1975 Hurst et al. .
- 3,919,596 11/1975 Bellis .
- 3,965,465 6/1976 Alexander .
- 3,984,757 10/1976 Gott et al. .
- 4,016,453 4/1977 Moennig .
- 4,031,408 6/1977 Holz .
- 4,071,689 1/1978 Talmage et al. .
- 4,101,805 7/1978 Stone .
- 4,119,864 10/1978 Petrizio .
- 4,152,629 5/1979 Raupp .
- 4,159,473 6/1979 Senk .
- 4,210,822 7/1980 Wern .
- 4,211,959 7/1980 Deavenport et al. .
- 4,213,061 7/1980 Conner .
- 4,220,815 9/1980 Gibson et al. .
- 4,237,421 12/1980 Waldron .
- 4,246,533 1/1981 Chiang .
- 4,257,117 3/1981 Besson .
- 4,264,831 4/1981 Wern .
- 4,289,972 9/1981 Wern .
- 4,289,980 9/1981 McLaughlin .

- 4,308,443 12/1981 Tucker et al. .
- 4,323,829 4/1982 Witney et al. .
- 4,352,141 9/1982 Kent 363/181
- 4,360,737 11/1982 Leopold .
- 4,374,381 2/1983 Ng et al. .
- 4,476,463 10/1984 Ng et al. .
- 4,503,294 3/1985 Matsumaru 200/5 A
- 4,731,548 3/1988 Ingraham .
- 4,758,735 7/1988 Ingraham .
- 4,831,279 5/1989 Ingraham .
- 4,910,504 3/1990 Eriksson .
- 4,939,382 7/1990 Gruodis .
- 4,942,631 7/1990 Rosa 4/623
- 5,012,124 4/1991 Hollaway .
- 5,066,898 11/1991 Miller et al. .
- 5,087,825 2/1992 Ingraham .
- 5,208,516 5/1993 Saidian .
- 5,233,231 8/1993 Wieth et al. .
- 5,235,217 8/1993 Kirton 307/326
- 5,386,219 1/1995 Greanias et al. .
- 5,453,644 9/1995 Yap et al. .
- 5,572,205 11/1996 Caldwell et al. 341/33

Primary Examiner—William M. Shoop, Jr.
Assistant Examiner—Jonathan Kaplan
Attorney, Agent, or Firm—Price, Heneveld, Cooper, DeWitt & Litton

[57] **ABSTRACT**

A capacitive responsive electronic switching circuit comprises an oscillator providing a periodic output signal having a frequency of 50 kHz or greater, an input touch terminal defining an area for an operator provide an input by proximity and touch, and a detector circuit coupled to the oscillator for receiving the periodic output signal from the oscillator, and coupled to the input touch terminal. The detector circuit being responsive to signals from the oscillator and the presence of an operator's body capacitance to ground coupled to the touch terminal when in proximity or touched by an operator to provide a control output signal. Preferably, the oscillator provides a periodic output signal having a frequency of 800 kHz or greater. An array of touch terminals may be provided in close proximity due to the reduction in crosstalk that may result from contaminants by utilizing an oscillator outputting a signal having a frequency of 50 kHz or greater.

32 Claims, 13 Drawing Sheets

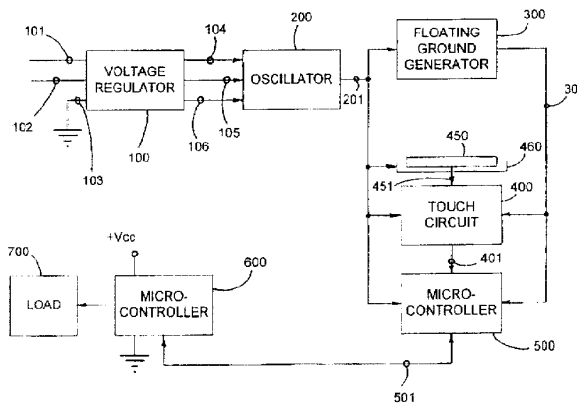

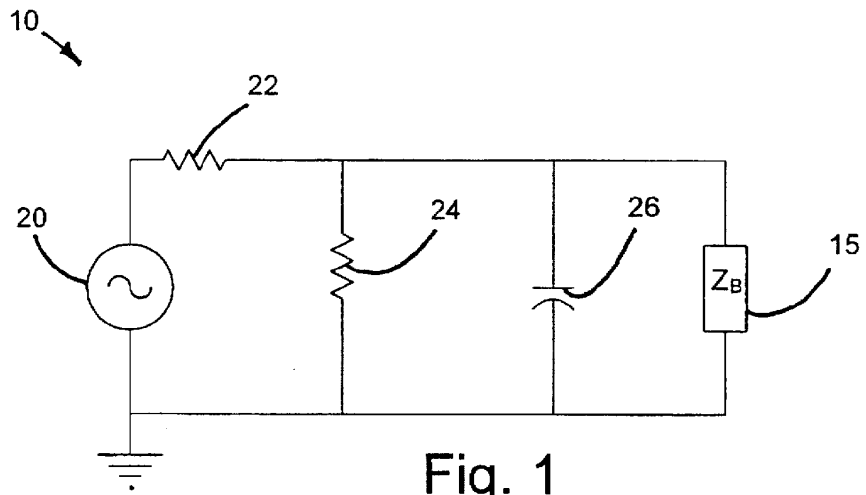

Fig. 1

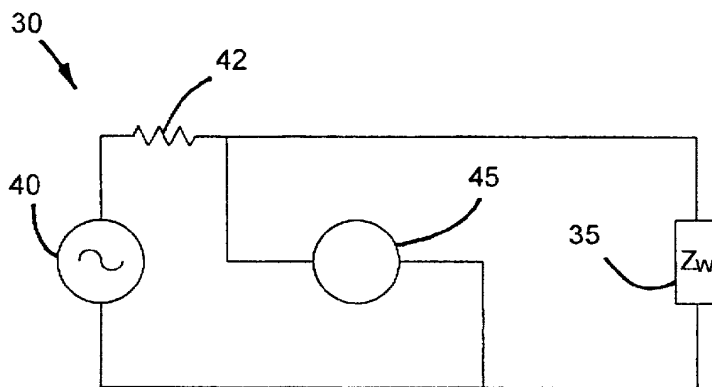

Fig. 2

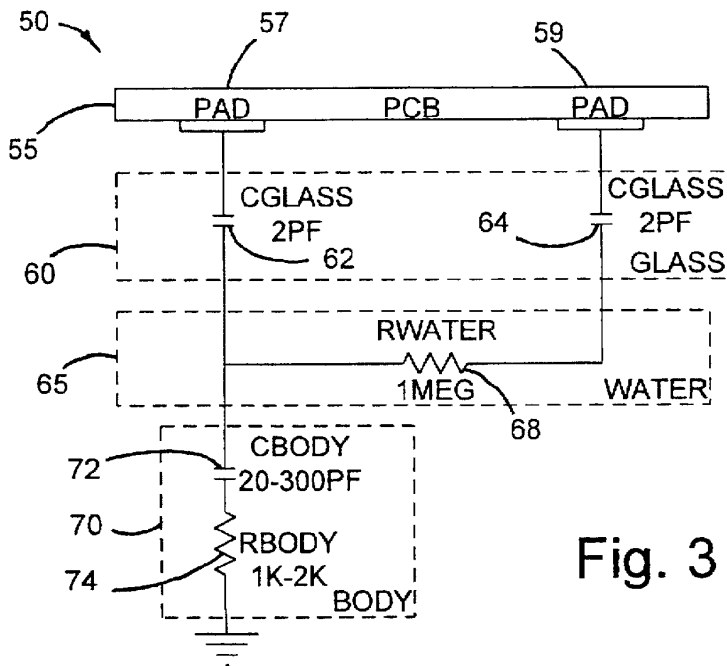

Fig. 3

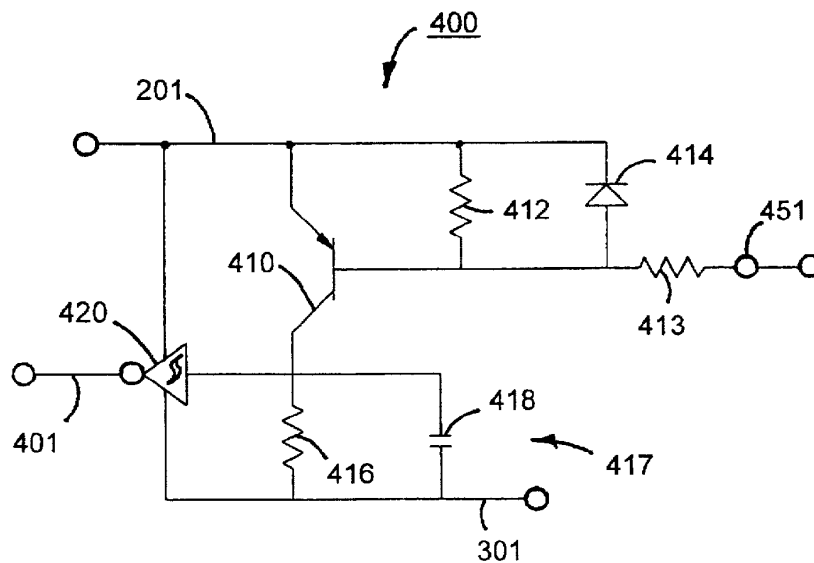

Fig. 8

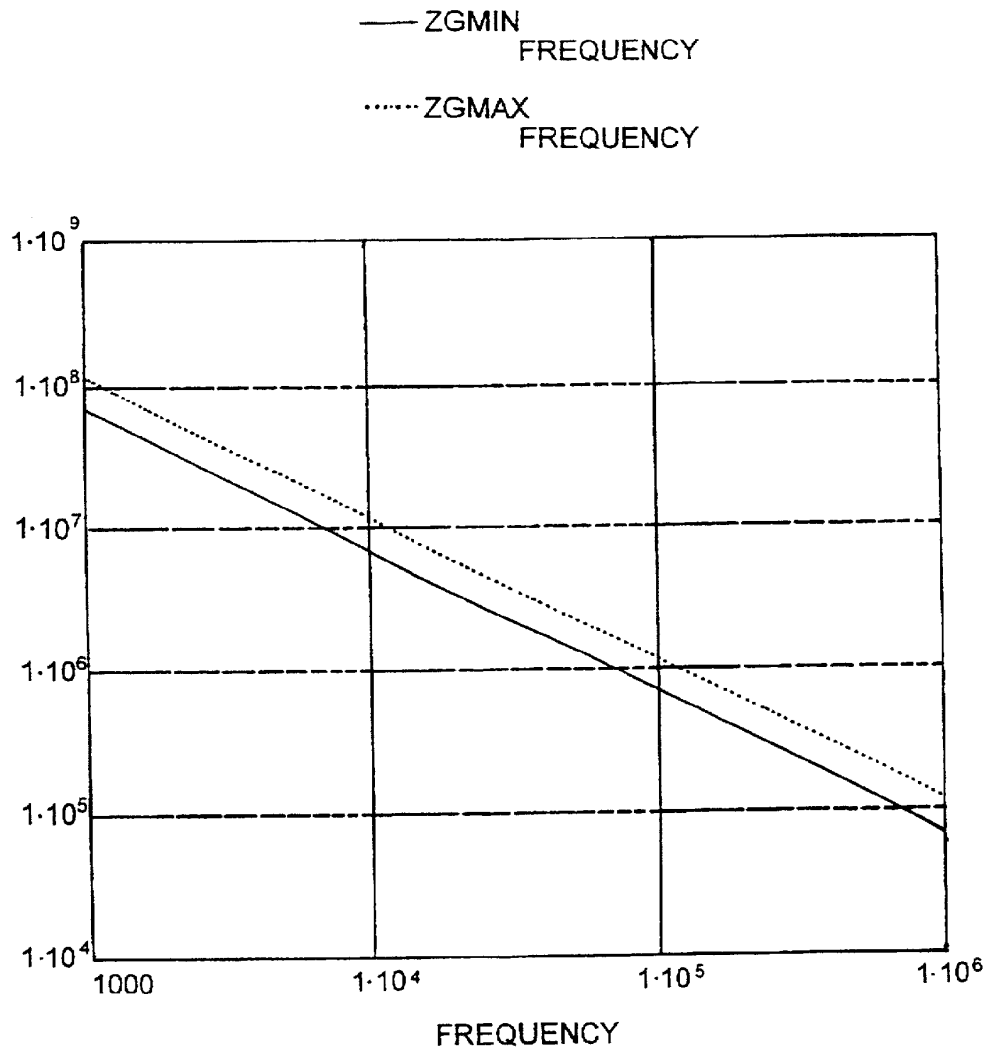

Fig. 3A

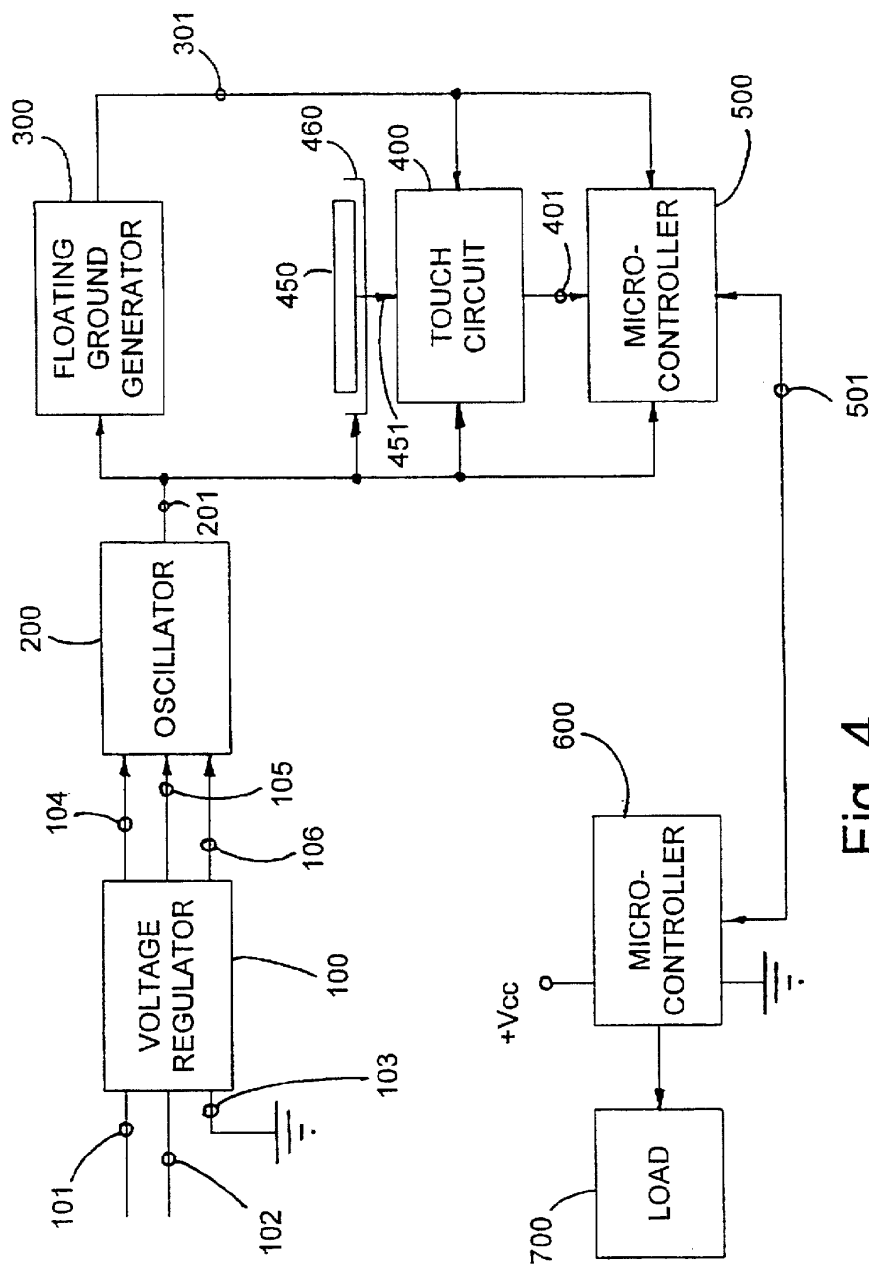
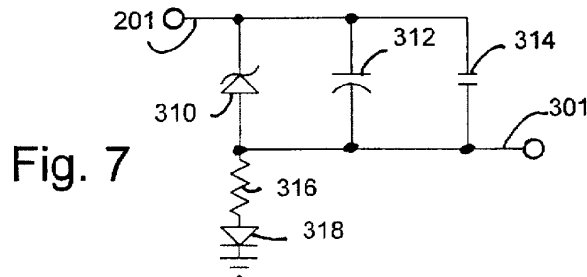
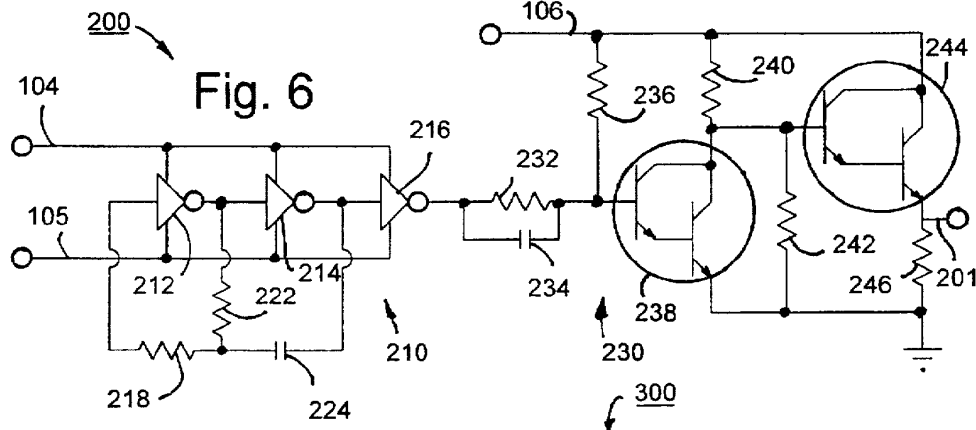
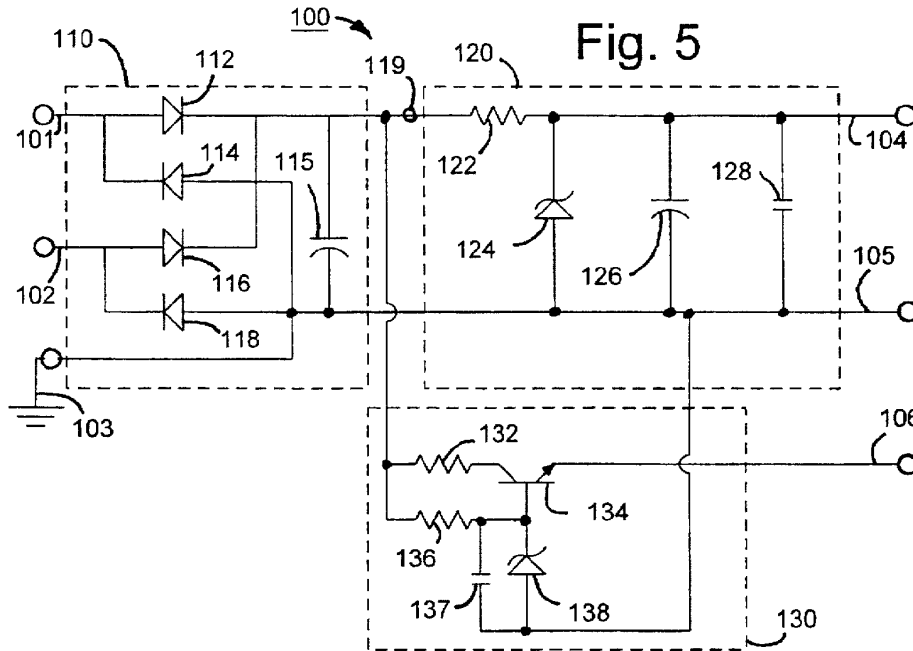

Fig. 4



S/N VS. BODY CAPACITANCE
TEMPERATURE = 105°C

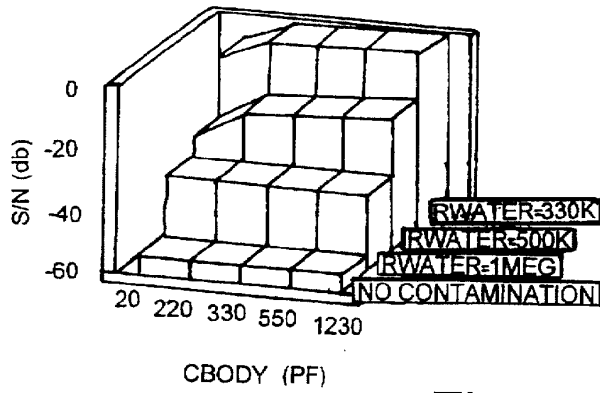

Fig. 9

S/N VS. BODY CAPACITANCE
TEMPERATURE = 25°C

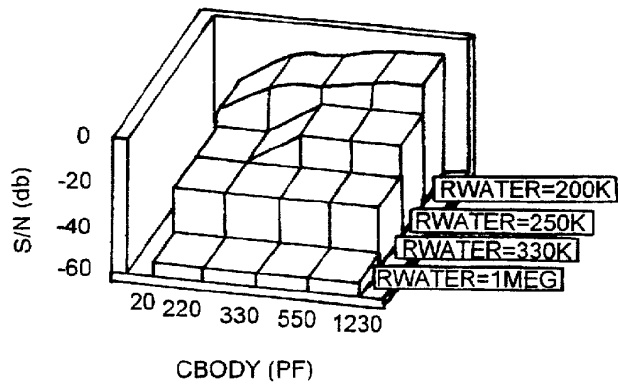
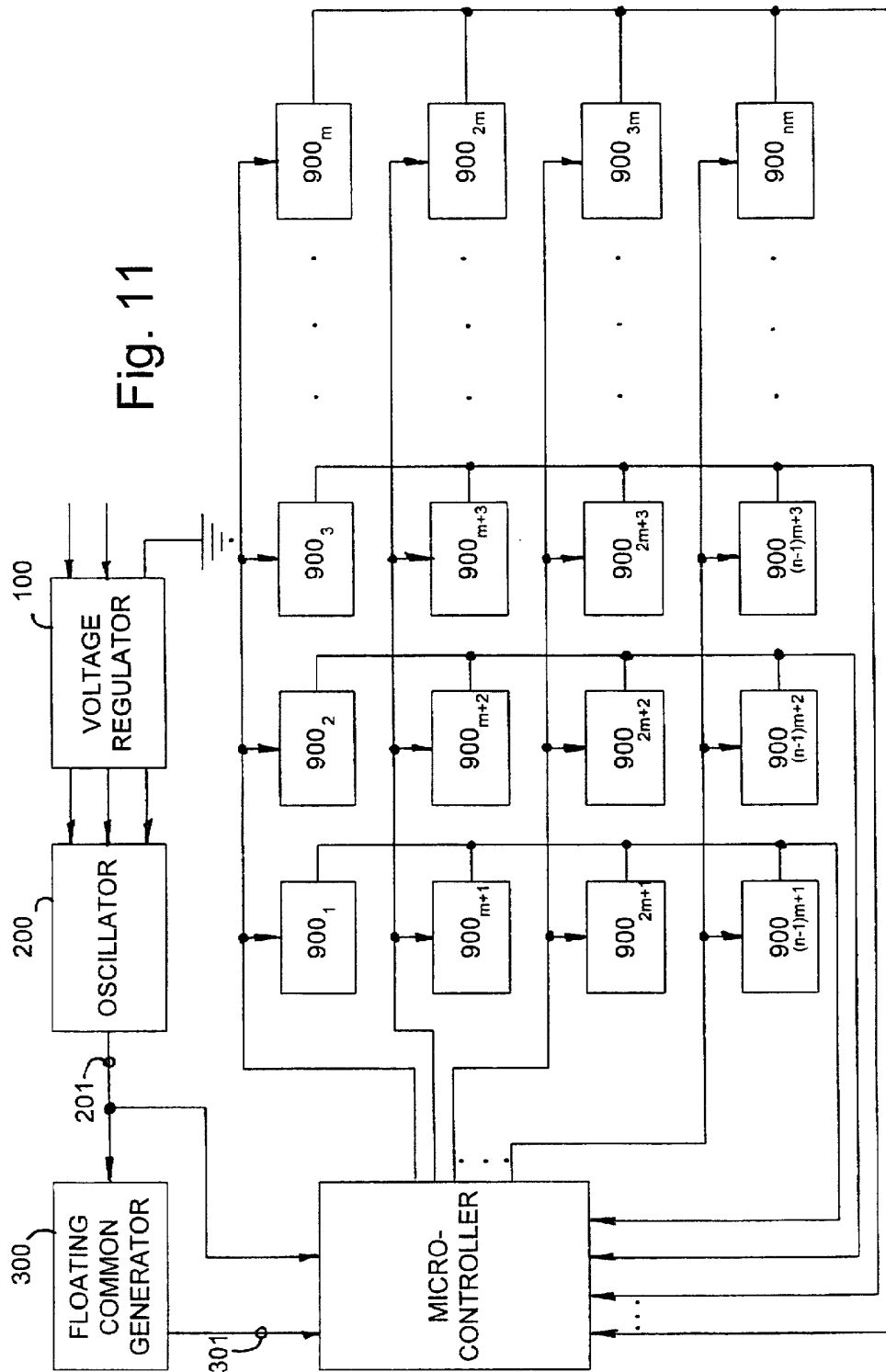

Fig. 10

Fig. 11



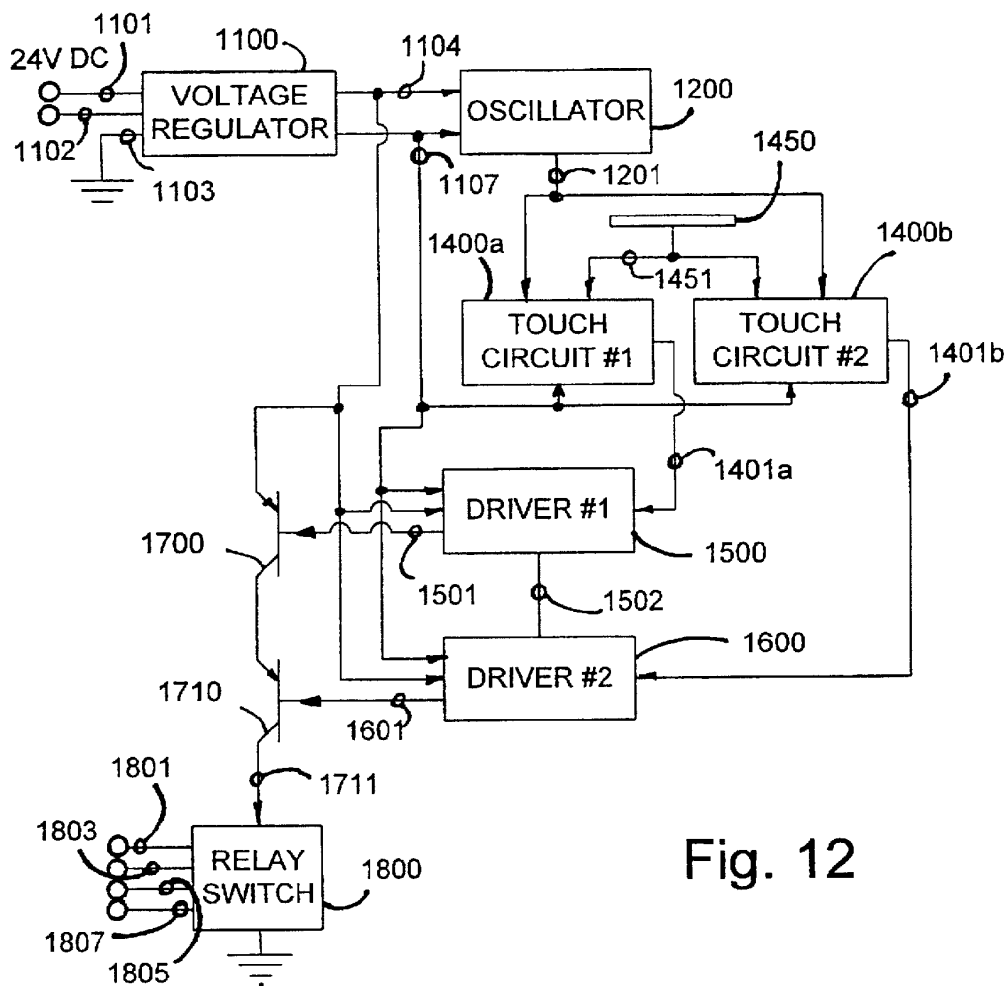

Fig. 12

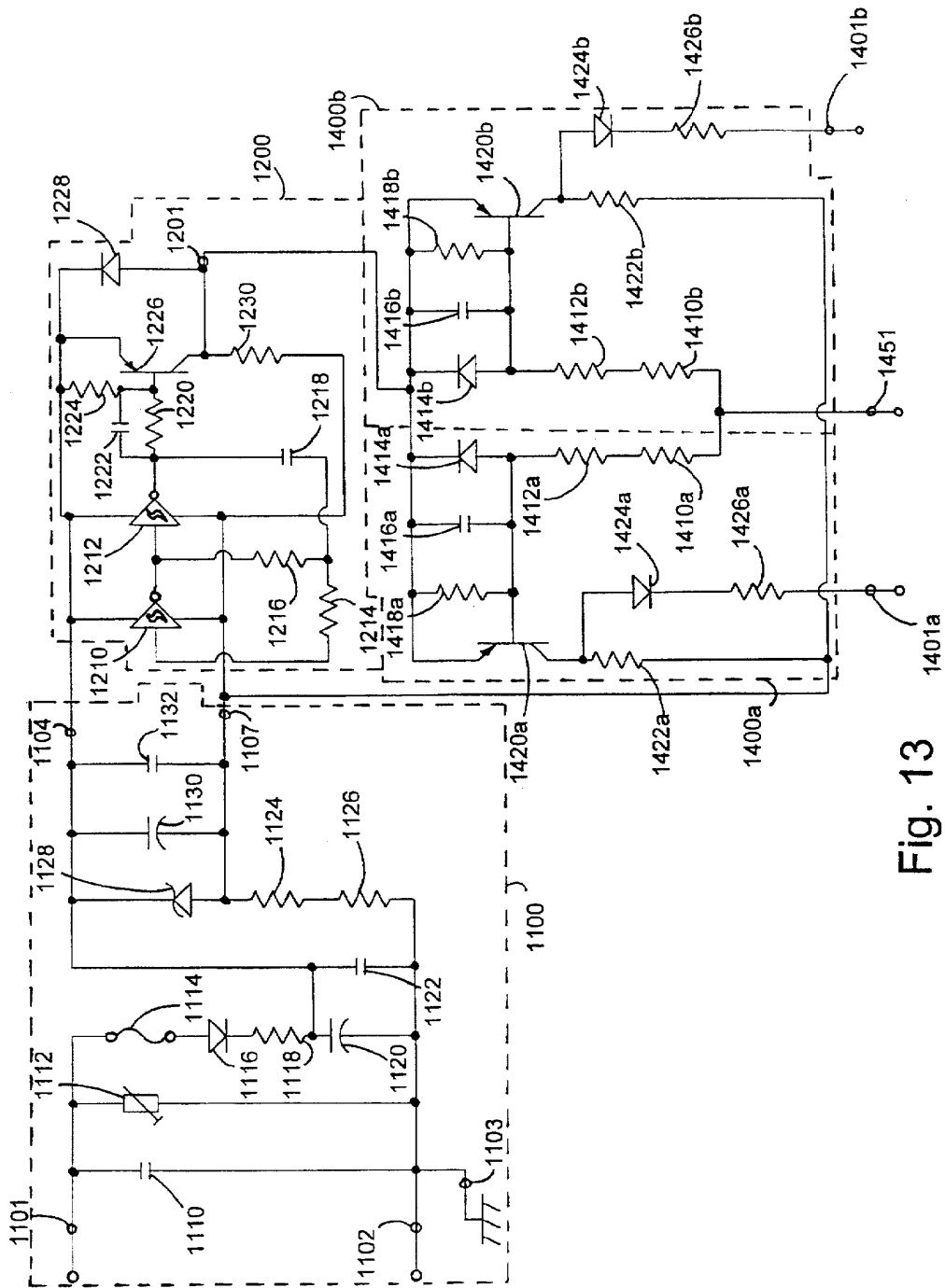

Fig. 13

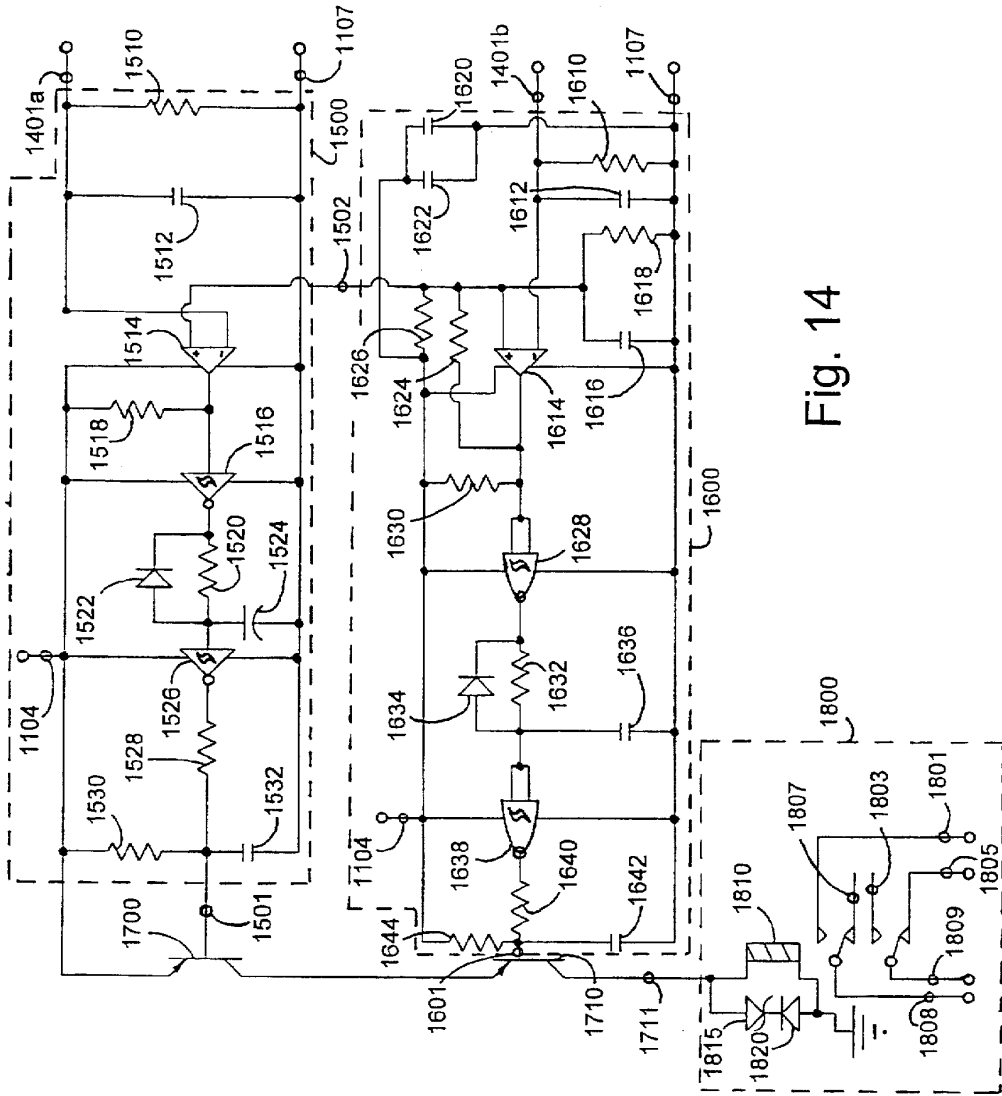
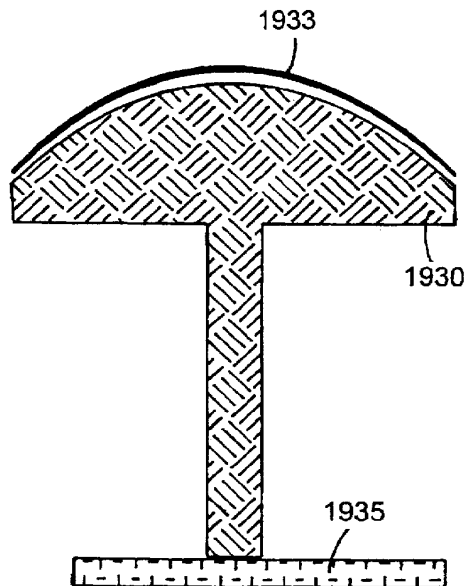
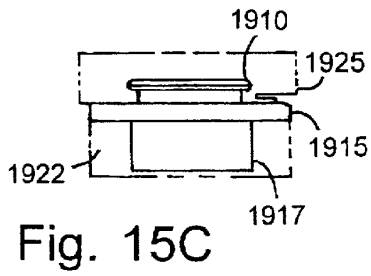
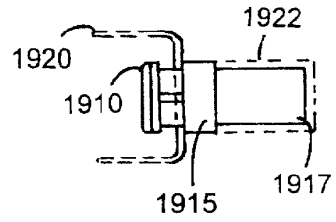
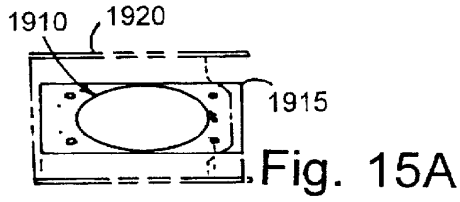

Fig. 14



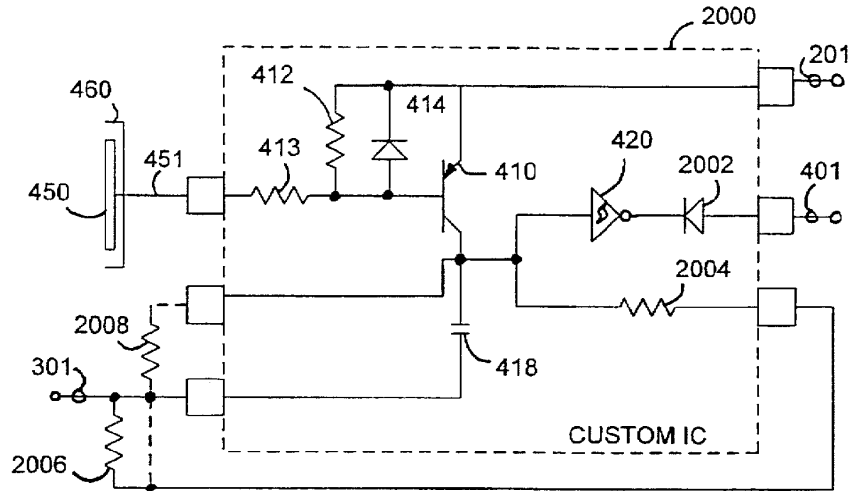

Fig. 17

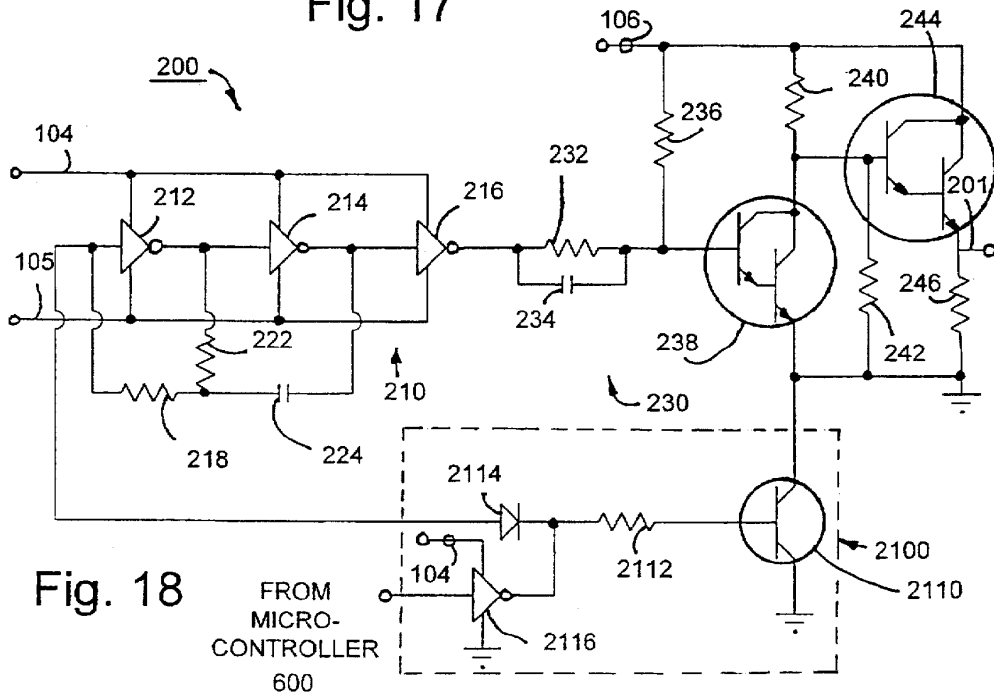

Fig. 18

FROM
MICRO-
CONTROLLER
600

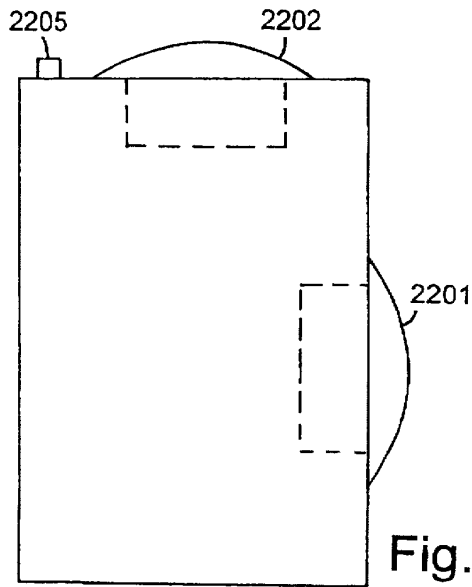

Fig. 19

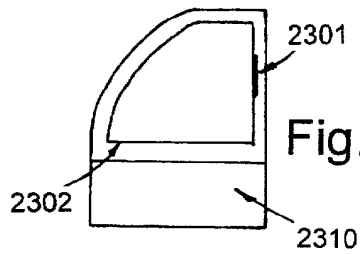

Fig. 20A

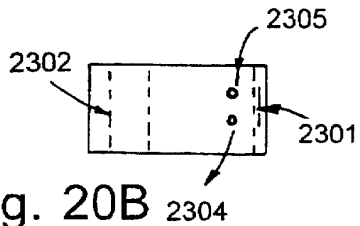

Fig. 20B

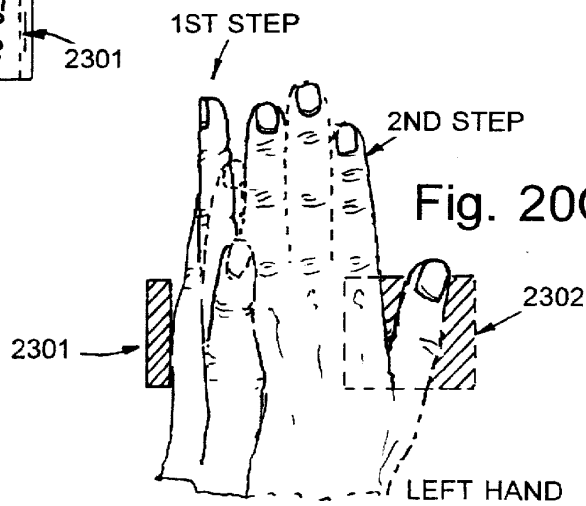

Fig. 20C

CAPACITIVE RESPONSIVE ELECTRONIC SWITCHING CIRCUIT

BACKGROUND OF THE INVENTION

The present invention relates to an electrical circuit and particularly a capacitive responsive electronic switching circuit used to make possible a "zero force" manual electronic switch.

Manual switches are well known in the art existing in the familiar forms of the common toggle light switch, pull cord switches, push button switches, and keyboard switches among others. The majority of such switches employ a mechanical contact that "makes" and "breaks" the circuit to be switched as the switch is moved to a closed or an open condition.

Switches that operate by a mechanical contact have a number of well known problems. First, mechanical movements of components within any mechanism make those components susceptible to wear, fatigue, and loosening. This is a progressive problem that occurs with use and leads to eventual failure when a sufficient amount of movement has occurred.

Second, a sudden "make" or "break" between conductive contacts typically produces an electrical arc as the contacts come into close proximity. This arcing action generates both radio frequency emissions and high frequency noise on the line that is switched.

Third, the separation between contacts that occurs on each break, exposes the contact surfaces to corrosion and contamination. A particular problem occurs when the arc associated with a "make" or "break" occurs in an oxidizing atmosphere. The heat of the arc in the presence of oxygen facilitates the formation of oxides on the contact surfaces. Once exposed, the contact surfaces of mechanical switches are also vulnerable to contaminants. Water borne contaminants such as oils and salts can be a particular problem on the contact surfaces of switches. A related problem occurs in that the repeated arcing of mechanical contact can result in a migration of contact materials away from the area of the mechanical contact. Corrosion, contamination, and migration operating independently or in combination often lead to eventual switch failure where the switch seizes in a closed or opened condition.

An additional problem results from the mechanical force required in operating a mechanical switch. This problem occurs in systems where a human operator is required to repetitively operate a given switch or a number of switches. Such repetitive motions commonly occur in the operation of electronic keyboards such as those used with computers and in industrial switches such as used in forming and assembly equipment among other applications. A common type of industrial switch is the palm button seen in pressing and insertion equipment. For safety purposes, the operator must press the switch before an insertion or pressing can occur. This ensures that the operators hand(s) is(are) on the button (s) and not in the field of motion of the associated machinery. It also ensures that the mechanical motion occurs at a desired and controllable point in time. The difficulty arises from the motion and force required of the operator. In recent years, it has been noted that repeated human motions can result in debilitating and painful wear on joints and soft tissues yielding arthritis like symptoms. Such repetitive motion may result in swelling and cramping in muscle tissues associated with conditions such as Carpal Tunnel Syndrome. Equipment designers combat these Repetitive Motion or Cumulative

lative Trauma Disorders by adopting ergonomic designs that more favorably control the range, angle, number, and force of motions required of an operator as well as the number of the operator's muscle groups involved in the required motions. Prosthetics and tests are used as well to provide strain relief for the operator's muscles, joints, and tendons.

In mechanical switches, the force required to actuate the switch may be minimized by reducing spring forces and frictional forces between moving parts. However, reducing such forces makes such switches more vulnerable to failure. For instance, weaker springs typically lower the pressure between contacts in a "make" condition. This lower contact pressure increases the resistance in the switch which can lead to fatal heating in the switch and/or loss of voltage applied to the switched load. Reducing frictional forces in the switch by increasing the use of lubricants is undesirable because the lubricants can migrate and contaminate the contact surfaces. A switch designer may also reduce friction by providing looser fits between moving parts. However, looser fits tend to increase wear and contribute to earlier switch failure. A designer can also reduce friction by using higher quality, higher cost, surface finishes on the parts. Thus, as apparent from the foregoing description, measures taken to reduce actuator force in mechanical switch parts generally reduce the reliability and performance of the switch and/or increase the cost of the switch.

In applications such as computer keyboards or appliance controls, the electric load switched by a given switch can be quite low in terms of current and/or voltage. In such cases it is possible to use low force membrane switches such as described in U.S. Pat. No. 4,503,294. Such switches can relieve operator strain and are not as susceptible to arcing problems because they switch small loads. However, the flexible membrane remains susceptible to wear, corrosion, and contamination. Although such switches require very low actuation force, they are still mechanically based and thus suffer from the same problems as any other mechanical switch.

A more recent innovation is the development of "zero force" touch switches. These switches have no moving parts and no contact surfaces that directly switch loads. Rather, these switches operate by detecting the operator's touch and then use solid state electronics to switch the loads or activate mechanical relays or triacs to switch even larger loads. Approaches include optical proximity or motion detectors to detect the presence or motion of a body part such as in the automatic controls used in urinals in some public rest rooms or as disclosed in U.S. Pat. No. 4,942,631. Although these non-contact switches are by their very nature truly zero force, they are not practical where a multiplicity of switches are required in a small area such as a keyboard. Among other problems, these non-contact switches suffer from the comparatively high cost of electro-optics and from false detections when the operator's hand or other body part unintentionally comes close to the switch's area of detection. Some optical touch keyboards have been proposed, but none have enjoyed commercial success due to performance and/or cost considerations.

A further solution has been to detect the operator's touch via the electrical conductivity of the operator's skin. Such a system is described in U.S. Pat. No. 3,879,618. Problems with this system result from variations in the electrical conductivity of different operators due to variations in sweat, skin oils, or dryness, and from variable ambient conditions such as humidity. A further problem arises in that the touch surface of the switch that the operator touches must remain clean enough to provide an electrical conductivity path to

the operator. Such surfaces can be susceptible to contamination, corrosion, and/or a wearing away of the conductive material. Also, these switches do not work if the operator is wearing a glove. Safety considerations also arise by virtue of the operators placing their body in electrical contact with the switch electronics. A further problem arises in that such systems are vulnerable to contact with materials that are equally or more conductive than human skin. For instance, water condensation can provide a conductive path as good as that of an operator's skin, resulting in a false activation.

A common solution used to achieve a zero force touch switch has been to make use of the capacitance of the human operator. Such switches, which are hereinafter referred to as capacitive touch switches, utilize one of at least three different methodologies. The first method involves detecting RF or other high frequency noise that a human operator can capacitively couple to a touch terminal when the operator makes contact such as is disclosed in U.S. Pat. No. 5,066,898. One common source of noise is 60 Hz noise radiated from commercial power lines. A drawback of this approach is that radiated electrical noise can vary in intensity from locale to locale and thereby cause variations in switch sensitivity. In some cases, devices implemented using this first method, rely on conductive contact between the operator and the touch terminal of the switch. As stated, such surfaces are subject to contamination, corrosion, and wear and will not work with gloved hands. An additional problem can arise in the presence of moisture when multiple switches are employed in a dense array such as a keyboard. In such instances, the operator may touch one touch terminal, but end up inadvertently activating others through the path of conduction caused by the moisture contamination.

A second method for implementing capacitive touch switches is to couple the capacitance of the operator into a variable oscillator circuit that outputs a signal having a frequency that varies with the capacitance seen at a touch terminal. An example of such a system is described in U.S. Pat. No. 5,235,217. Problems with such a system can arise where conductive contact with the operator is required and where the frequency change caused by a touch is close to the frequency changes that would result from unintentionally coming into contact with the touch terminal.

Another method for implementing capacitive touch switches relies on the change in capacitive coupling between a touch terminal and ground. Systems utilizing such a method are described in U.S. Pat. No. 4,758,735 and U.S. Pat. No. 5,087,825. With this methodology the detection circuit consists of an oscillator (or AC line voltage derivative) providing a signal to a touch terminal whose voltage is then monitored by a detector. The touch terminal is driven in electrical series with other components that function in part as a charge pump. The touch of an operator then provides a capacitive short to ground via the operator's own body capacitance that lowers the amplitude of oscillator voltage seen at the touch terminal. A major advantage of this methodology is that the operator need not come in conductive contact with the touch terminal but rather only in close proximity to it. A further advantage arises in that the system does not rely upon radiated emissions picked up by the operator's body which can vary with locale, but relies instead upon the human body's capacitance, which can vary over an acceptable range of 20 pF to 300 pF.

An additional consideration in using zero force switches resides in the difficulties that arise in trying to employ dense arrays of such switches. Touch switches that do not require physical contact with the operator but rather rely on the

operator's close proximity can result in unintended actuations as an operator's hand or other body part passes in close proximity to the touch terminals. Above-mentioned U.S. Pat. No. 5,087,825 employs conductive guard rings around the conductive pad of each touch terminal in an effort to decouple adjacent touch pads and prevent multiple actuations where only a single one is desired. In conjunction with the guard rings, it is also possible to adjust the detection sensitivity by adjusting the threshold voltage to which the sensed voltage is compared. The sensitivity may be adjusted in this manner to a point where the operator's body part, for instance, a finger, has to entirely overlap a touch terminal and come into contact with its dielectric facing plate before actuation occurs. Although these methods (guard rings and sensitivity adjustment) have gone a considerable way in allowing touch switches to be spaced in comparatively close proximity, a susceptibility to surface contamination remains as a problem. Skin oils, water, and other contaminants can form conductive films that overlay and capacitively couple adjacent or multiple touch pads. An operator making contact with the film can then couple multiple touch pads to his or her body capacitance and it's capacitive coupling to ground. This can result in multiple actuations where only one is desired. Small touch terminals placed in close proximity by necessity require sensitive detection circuits that in some cases are preferably isolated from interference with the associated load switching circuits that they activate.

As mentioned, in industrial controls, switches can be used to control actuation time and to ensure that the operator's hand(s) or other body part(s) are out of the field of motion of associated machinery. A common type of switch used in this application is the palm button. The button is large enough so that the operator can rapidly bring his or her hand into contact with the button without having to lose the time that would be taken in acquiring and lining up a finger with a smaller switch. Zero force touch switches are also desirable in this application as Repetitive Motion or Cumulative Trauma Disorders have been a problem with operator's utilizing palm buttons—especially those palm buttons that must be actuated against a spring resistance. In this area capacitive touch switches have also been employed. U.S. Pat. No. 5,233,231 is an example of such an implementation. Due to the proximity of machinery with the potential to cause injury, false actuations are a particular liability in such applications. Capacitive touch switches that exhibit vulnerability to radiated electromagnetic noise or that operate off operator proximity have the potential to actuate when the operator's hand(s) is not at the desired location on the palm button(s). In general, this is addressed by the use of redundancies. In U.S. Pat. No. 5,233,231, a separate detector is used to measure RF noise and disable the system to a safe state if excessive RF noise is present. Other systems such as UltraTouch vended by Pinnacle Systems, Inc. use redundant sensing methodologies. In UltraTouch, both optical and capacitive sensors are used and actuation occurs only when both sensor types detect the operator's hand at the desired location. These implementations have a number of disadvantages. In the case of the RF noise detection system, the system is unusable in the presence of RF noise. This forces the user to employ a backup mechanical switch system or accept the loss of function when RF noise is present. The second system is less reliable and more expensive because it requires two sensor systems to accomplish the same task, i.e., detect the operator. Such system may also suffer from problems inherent in any optical system, namely, susceptibility to blockages in the optical path and the need to achieve and maintain specific optical alignments. A further problem

is that this system considerably constrains the angle and direction of motion that the operator must use in activating the switch.

Currently, there are several zero force palm buttons in the market. These products utilize optical and/or capacitive coupling to activate a normally closed (NC) or a normally open (NO) relay, and thereby switching 110 V AC, 220 V AC, or 24 V DC to machine controllers. The UltraTouch by Pinnacle Systems Inc. uses two sensors (infrared & capacitive) with isolated circuits to activate a relay when a machine operator inserts his hand into a U-shaped sensor actuation tunnel. The company claims that by permitting the machine operator to activate the machine with no force or pressure and with the operator's hand and wrist in the ergonomic neutral position (i.e. 0° wrist joint angle and 100% hand power positions as shown in FIG. 1.0-1), hand, wrist, and arm stresses are minimized and contributing elements to Carpal Tunnel Syndrome are negated. After a machine cycle is initiated, the operator must maintain an initial posture until the cycle is completed. A typical cycle time lasts approximately one to two seconds and is repeated about 3000 times daily. This adds up to about one hour to one hour and a half per day while the operator is in the posture. While this module reduces stress on wrist and hand, it strains the muscles in the forearm. Also, because of limited space permitted for the operator to insert his hand, it stresses the operator mentally and reduces productivity by causing fatigue. Furthermore, the infrared emitters and detectors rely on a clean path between the transmitter and receiver and will not operate properly if contaminants block the beam of light.

SUMMARY OF THE INVENTION

The present invention overcomes the above problems by using the method of sensing body capacitance to ground in conjunction with redundant detection circuits. Additional improvements are offered in the construction of the touch terminal (palm button) itself and in the regime of body capacitance to ground detection which minimizes sensitivity to skin oils and other contaminants. The invention also allows the operator to utilize the system with or without gloves which is a particular advantage in the industrial setting.

The specific touch detection method of the present invention has similarities to the devices of U.S. Pat. No. 4,758,735 and U.S. Pat. No. 5,087,825. However, significant improvements are offered in the means of detection and in the development of an overall system to employ the touch switches in a dense array and in an improved zero force palm button. The touch detection circuit of the present invention features operation at frequencies at or above 50 kHz and preferably at or above 800 kHz to minimize the effects of surface contamination from materials such as skin oils and water. It also offers improvements in detection sensitivity that allow close control of the degree of proximity (ideally very close proximity) that is required for actuation and to enable employment of a multiplicity of small sized touch terminals in a physically close array such as a keyboard. The circuitry of the present invention minimizes the force required in human operator motions and eliminates awkward angles and other constraints required in those motions. The outer surface of the touch switch typically consists of a continuous dielectric layer such as glass or polycarbonate with no mechanical or electrical feed-throughs. The surface can be shaped to have no recesses that would trap or hold organic material. As a result it is easily cleaned and kept clean and so is ideal for hygienic applications such as medical or food processing equipment.

In a first preferred embodiment the circuit offers enhanced detection sensitivity to allow reliable operation with small (finger size) touch pads. Susceptibility to variations in supply voltage and noise are minimized by use of a floating common and supply that follow the oscillator signal to power the detection circuit. The enhanced sensitivity allows the use of a 26V or lower amplitude oscillator signal applied to the touch terminal and detection circuit. This lower voltage (as compared to the device of U.S. Pat. No. 4,758,735) obviates the need for expensive UL listed higher voltage construction measures and testing to handle what would otherwise be large enough voltages to cause safety concerns. A further advantage of the present invention is seen in the manner in which the touch terminal detection circuit is interfaced to the touch terminals and to external control systems. A dedicated microprocessor referenced to the floating supply and floating common of the detection circuit may be used to cost effectively multiplex a number of touch terminal detection circuits and multiplex the associated touch terminal output signals over a two line optical bus to a dedicated microprocessor referenced to a fixed supply and ground. An additional advantage of the microprocessor is an expanded ability to detect faults, i.e. a pad that is touched for an excessive amount of time that is known a priori to be an unlikely mode of operation or two or more pads touched at the same time or in an improper order. Additionally, the microprocessor can be used to distinguish desired multiple pad touches in simultaneous or sequential modes, i.e. two or more switches touched in a given order within a given amount of time. The microprocessor can be used to perform system diagnostics as well. The microprocessor also allows the use of visual indicators such as LEDs or annunciators such as a bell or tone generator to confirm the actuation of a given touch switch or switches. This is particularly useful in cases where a sequence of actuations is required before an action occurs. The feedback to the operator provided by a visual or audio indicator activated by the microprocessor in response to intermediate touches in a required sequence can minimize time lost and/or frustration on the part of the operator due to failed actuations from partial touches or wrong actuations from touching the wrong pad in a given required sequence or combination of touches. The second microprocessor may be used to communicate with the user's control system. Additional features include a "sleep mode" to minimize power consumption during periods of non-use or power brown outs, and redundant control circuits to facilitate "fail to safe" operation. Another improvement is offered in a means to move much of the cost of the system into simplified custom integrated circuits that allow ease of sensitivity adjustment and assembly.

In a second preferred embodiment, an improved palm button is featured. Through the use of a dielectric cover, a large metallic touch terminal can be used that differentiates between the touch of a finger or partial touch and the full touch of a palm. In this way the system avoids false triggers due to inadvertent finger touches or brushing contact with the palm prior or after an intended touch. The second embodiment also features redundant control circuits to facilitate "fail to safe" operation.

To achieve these and other advantages, and in accordance with the purpose of the invention as embodied and described herein, the capacitive responsive electronic switching circuit comprises an oscillator providing a periodic output signal having a frequency of 50 kHz or greater, an input touch terminal defining an area for an operator to provide an input by touch, and a detector circuit coupled to the oscillator for receiving the periodic output signal from the oscillator, and

coupled to the input touch terminal. The detector circuit being responsive to signals from the oscillator and the presence of an operator's body capacitance to ground coupled to the touch terminal when touched by an operator to provide a control output signal. Preferably, the oscillator provides a periodic output signal having a frequency of 800 kHz or greater.

These and other features, objects, and advantages of the invention may be realized and obtained by means of the instrumentalities and combinations particularly pointed out in the written description and claims hereof, as well as by the appended drawings.

BRIEF DESCRIPTION OF THE DRAWINGS

FIG. 1 is an electrical schematic of a testing circuit used to measure the impedance of the human body;

FIG. 2 is an electrical schematic of a testing circuit used to measure the impedance of water;

FIG. 3 is an electrical schematic of an equivalent circuit model for analyzing a human body in contact with glass covered with water;

FIG. 4 is a block diagram of a capacitive responsive electronic switching circuit constructed in accordance with a first embodiment of the present invention;

FIG. 5 is an electrical schematic of a preferred voltage regulator circuit for use in the capacitive responsive electronic switching circuit shown in FIG. 4;

FIG. 6 is an electrical schematic of a preferred oscillator circuit for use in the capacitive responsive electronic switching circuit shown in FIG. 4;

FIG. 7 is an electrical schematic of a preferred floating common generator circuit for use in the capacitive responsive electronic switching circuit shown in FIG. 4;

FIG. 8 is an electrical schematic of a preferred touch circuit for use in the capacitive responsive electronic switching circuit shown in FIG. 4;

FIG. 9 is a three dimensional bar graph illustrating signal-to-noise ratio vs. body capacitance at T=105° C.;

FIG. 10 is a three dimensional bar graph illustrating signal-to-noise ratio vs. body capacitance at T=22° C.;

FIG. 11 is a block diagram of a capacitive responsive electronic switching circuit constructed in accordance with a second embodiment of the present invention;

FIG. 12 is a block diagram of a capacitive responsive electronic switching circuit constructed in accordance with a third embodiment of the present invention;

FIG. 13 is an electrical schematic of a preferred voltage regulator, oscillator, and touch circuits for use in the capacitive responsive electronic switching circuit shown in FIG. 12;

FIG. 14 is an electrical schematic of preferred driver circuits for use in the capacitive responsive electronic switching circuit shown in FIG. 12;

FIGS. 15A-C are top, side, and front views, respectively, of an example of a flat palm button constructed in accordance with the present invention;

FIG. 16 is a cross-sectional view of an example of a dome-shaped palm button constructed in accordance with the present invention;

FIG. 17 is an electrical schematic of a touch circuit of the present invention implemented in a custom integrated circuit;

FIG. 18 is an electrical schematic of an oscillator having a sleeper circuit for use in the capacitive responsive electronic switching circuits of the present invention;

FIG. 19 is a pictorial view of a device having two palm buttons and an indicator light operated in accordance with the present invention; and

FIGS. 20A-C are pictorial views of another embodiment of the device shown in FIG. 19.

DETAILED DESCRIPTION OF THE PREFERRED EMBODIMENTS

As apparent from the above summary, the touch circuit of present invention operates at a higher frequency than prior touch sensing circuits. A move to high frequency operation (>50 to 800 kHz) is not a benign choice relative to the lower frequency (60 to 1000 Hz) operation seen in existing art such as U.S. Pat. No. 4,758,735 and U.S. Pat. No. 5,087,825. Higher frequencies require generally more costly, higher speed parts, and often results in the added cost of special design measures to minimize electronic emissions and the introduction of high frequency noise on power supply lines. The preference for using such higher frequencies is based on a study performed to determine if high frequency operation would allow a touch of an operator and conduction via surface contamination films, such as moisture, providing a conductive path from a non-touched area to the touched area. The study also determined whether a high frequency touch circuit could operate over a sufficiently wide temperature range, an assortment of overlying dielectric layer thicknesses and materials, and in the presence of likely power supply fluctuations. The following calculations and measurements are the results of this study. The results summarize the investigation conducted to reduce crosstalk due to condensation of water on the dielectric member (glass). By increasing the frequency of operation, the impedance of the body-glass combination is reduced as compared to the impedance of water between the touch pads.

The equivalent circuit of body impedance was measured using the testing circuit 10 shown in FIG. 1. Testing circuit 10 includes an oscillator 20 coupled between ground plate and a 100 kΩ series resistor 22 and in parallel with a 10 MΩ resistor 24, a 20 pF capacitor 26, and contacts for connecting to a human body identified in the figure as an impedance load 15 having an impedance Z_B representing the body's impedance.

Two types of measurements were taken: one with the person under test standing on a large ground plane i.e., concrete slab; and another while standing on a subfloor. The subfloor was used to simulate a typical northern home, i.e., wood joists with plywood sheeting. Carpeting was used as an added insulation layer. Table 1 below shows the measured body resistance and capacitance for five individuals.

TABLE 1

CONCRETE SLAB	CONCRETE SLAB	SUBFLOOR	SUBFLOOR
1.4 kΩ	100 pF	1.7 kΩ	73 pF
1.4 kΩ	217 pF	1.9 kΩ	78 pF
1.3 kΩ	174 pF	1.9 kΩ	93 pF
1.2 kΩ	160 pF	1.6 kΩ	85 pF
1.0 kΩ	107 pF	1.4 kΩ	75 pF

As apparent from Table 1 above and the discussion to follow, a human body's impedance may be represented by the series combination of a 20-300 pF capacitor and a 1 k-2 kΩ resistor.

The impedance of water, which is mainly resistive, was measured using the testing circuit 30 shown in FIG. 2. Testing circuit 30 includes an oscillator 40 coupled in series with a 1 MΩ resistor 42 and contacts across which water is

applied to define an impedance load **35** having an impedance Z_w representing the impedance of water. A true RMS voltage meter **45** is connected across the contacts of the impedance load **35**.

The resistance of tap water over a 1x1 inch area and 1/32 inch deep, was measured to be around 160 kΩ.

The following calculation is for resistance of rain water where c is the conductivity for rain:

$$R = \left(\frac{1}{cin} \right) \times \left(\frac{L}{A} \right)$$

where,

$$c = 128 \times 10^{-6} (\Omega - cm)^{-1}$$

$$cin = c \left(\frac{100 \text{ cm}}{\text{m}} \right) \left(\frac{.0254 \text{ m}}{\text{in}} \right)$$

$$L = 1.0 \text{ in}$$

$$A = (1.0) \times \left(\frac{1}{32} \right) = \frac{1}{32} \text{ in}^2$$

therefore,

$$R = \left(\frac{1}{325.12 \times 10^{-6}} \right) \times \left(\frac{1.0 \text{ in}}{\frac{1}{32} \text{ in}^2} \right) = 98.43 \text{ k}\Omega$$

However, the thickness of a layer of water condensed on the surface of glass is much less than 1/32 inch and it's resistance is higher than that of tap water. For design purposes, a resistance value of 1 MΩ was used to simulate water.

The capacitance of a piece of glass measuring 1/2"x1/2"x1/4", is approximately 2 pF where,

$$C = K_{glass} K_a \frac{A(\text{cm}^2)}{L(\text{cm})} (\mu\text{F})$$

$$K_a = 0.08842 \times 10^{-6} \text{ for vacuum}$$

$$6.0 < K_{glass} < 10$$

$$A = 0.25 \text{ in}^2$$

$$L = 0.25 \text{ in}$$

therefore,

$$C_{max} = 10 \times 0.08842 \times 10^{-6} \times 2.54 \times 10^{-6} = 2.25 \text{ pF}$$

$$C_{min} = 6 \times 0.08842 \times 10^{-6} \times 2.54 \times 10^{-6} = 1.35 \text{ pF}$$

Table 2 below shows the dielectric constant for several types of glass:

TABLE 2

TYPE OF GLASS	Dielectric Constant (K)
Corning 0010	6.32
Corning 0080	6.75
Corning 0120	6.65
Corning 8870	9.5

The equivalent circuit **50** of body touching the glass with the presence of water is shown in FIG. 3. As shown, the equivalent circuit **50** includes a polycarbon (PCB) plate **55** having at least two pads **57** and **59** formed thereon, a glass plate **60** adjacent to PCB plate **55**, water **65** on glass plate **60** spanning at least two touch pad areas, and a body **70** in

contact with the water **65** and glass plate **60** at one touch pad area. The impedance of glass plate **60** is approximated by two 2 pF capacitors **62** and **64** connected to pads **57** and **59**, respectively. The water **65** is approximated by a 1 MΩ resistor **68** connected between capacitors **62** and **64**. The body is represented by a 20–300 pF capacitor **72** coupled at one end to water resistor **68** and glass plate capacitor **62**, and by a 1–2 kΩ resistor **74** coupled between the other end of capacitor **72** and ground.

Referring to FIG. 3, it can be seen that a human touch opposite pad **57** will couple pad **57** to ground through the capacitance of glass **62** and the series contact with the human body impedance provided by the 20–300 pF capacitance and the 1 k–2 kΩ resistance of a typical human body. This will have the effect of pulling any voltage on the pad towards ground. Pad **59** will be similarly effected, however it's coupling to ground will not only be through capacitance **64**, and the series capacitance and resistance of the human body, but will also be through the ohmic resistance of water on the glass cover between the proximate location of pad **59** and the touched pad **57**. Because the human capacitance is considerably greater than the 2 pF capacitance of the glass, the impedance of the path to ground for pads **57** and **59** will be dominated by the glass and water impedances. If the impedance of the water path is significant compared to that of the glass, then the effect of a touch will be more significant at pad **57** than at pad **59**. To overcome the effect of condensation or possible water spills, the impedance of the glass is preferably made as small as is practical compared to the impedance of the water. This allows discrimination between touched and adjacent pads. As the water impedance is primarily resistive and the glass impedance is primarily capacitive, the impedance of the glass will drop with frequency.

FIG. 3A shows the maximum and minimum glass impedance as a function of frequency. The maximum and minimum glass impedances shown were computed as follows:

$$\epsilon_o = 8.854 \times 10^{-12} \text{ C}^2 / (\text{nm}^2)$$

$$K_{glass} = 6$$

$$K_{glass} = 10$$

$$A = 0.25 \text{ in}^2$$

$$L = 0.25 \text{ in}$$

$$C_{max} = K_{glass} \epsilon_o A / L \quad C_{max} = 2.249 \text{ pF}$$

$$C_{min} = K_{glass} \epsilon_o A / L \quad C_{min} = 1.349 \text{ pF}$$

$$Z_{gmin \text{ frequency}} = 1 / (2 \pi C_{max} \text{ frequency})$$

$$Z_{gmax \text{ frequency}} = 1 / (2 \pi C_{min} \text{ frequency})$$

As can be seen, at 1 kHz, the capacitive impedance of the glass is much greater than the nominal 1 MΩ of the water bridge between the pads. As a result, at 1 kHz, there would be little difference in the impedance paths to ground of the two adjacent pads when either is touched. This would result in the voltage on both pads being pulled towards ground by comparable amounts. Conversely, at 100 kHz, the glass impedance drops to approximately 1 MΩ resulting in the impedance of the path to ground for pad **59** being twice that of the touched pad **57**. For cases where background noise and temperature drifts are comparatively small, a 100 kHz oscillator frequency would allow a sufficiently low detection threshold to be set to differentiate between the signal changes induced at both pads by a human touch opposite a

single pad. At 800 kHz, the impedance of the glass drops to 200 k Ω or lower giving a ratio of a greater than 5 to 1 impedance difference between the paths to ground of the touched pad 57 and adjacent pads 59. In fact, the impedance ratio may exceed 10 to 1, as illustrated in the calculation below. This allows the detection threshold for the touched pad to be set well below that of an adjacent pad resulting in a much lower incidence of inadvertent actuation of adjacent touch pads to that of the touched pad. Ideally, the frequency of operation would be kept at the 800 kHz of the preferred embodiment or even higher. However, as noted earlier, higher frequency operation forces the use of more expensive components and designs. For applications where thermal drift and electronic noise levels are low, operation at or near 100 kHz may be possible. However, at 10 kHz and below, the impedance of the glass becomes much greater than that of likely water bridges between pads resulting in adjacent pads being effected as much by a touch as the touched pad itself. Although the preferred frequency is at or above 100 kHz, and more preferably at or above 800 kHz, it is conceivable that frequencies as low as 50 kHz could be used provided the frequency creates a difference in the impedance paths of adjacent pads that is sufficient enough to accurately distinguish between an intended touch and the touch of an adjacent pad. Use of frequencies as low as 50 kHz may also be possible depending upon the type of glass or covering or the thickness thereof used for the touch pad. However, in cases where there is little or no surface contamination, the frequency of operation can go well below 50 kHz. Ultimately, the frequency chosen will be a tradeoff between the likelihood of surface contamination and the cost of going to higher frequencies to prevent cross talk due to such contamination. The following analysis illustrates one example of how a frequency may be calculated based on the typical parameters used to construct a touch switch and the typical impedance of a contaminant, such as rain water. In the analysis below a 10 to 1 ratio of water to glass impedance is sought.

To eliminate crosstalk due to condensation of water on the glass, the impedance of body (Z_b) and glass (Z_g) combination must be much lower than impedance of water (Z_w). Since the impedance of glass is much higher than body impedance, Z_g will be considered only. Therefore,

$$10|Z_g| < |Z_w| \quad \text{Eq. 3}$$

where,

$$C_{glass} = 2 \text{ pF } Z_w = 1 \text{ M}\Omega$$

$$Z_g = \frac{1}{2\pi f C_g} = \frac{7.96 \times 10^{10}}{f} \quad \text{Eq. 4}$$

$$10 \times \left(\frac{7.96 \times 10^{10}}{f} \right) < 1 \text{ M}\Omega$$

Therefore,

$$f > 796 \text{ kHz}$$

Having provided a basis for the use of higher frequencies, the basic construction of the electronic switching circuit constructed in accordance with a first embodiment of the present invention is now described with reference to FIG. 4. The electronic switching circuit includes a voltage regulator 100 including input lines 101 and 102 for receiving a 24 V AC line voltage and a line 103 for grounding the circuit. Voltage regulator 100 converts the received AC voltage to a

DC voltage and supplies a regulated 5 V DC power to an oscillator 200 via lines 104 and 105. Voltage regulator also supplies oscillator 200 with 26 V DC power via line 106. The details of voltage regulator 100 are discussed below with reference to FIG. 5.

Upon being powered by voltage regulator 100, oscillator 200 generates a square wave with a frequency of 50 kHz, and preferably greater than 800 kHz, and having an amplitude of 26 V peak. The square wave generated by oscillator 200 is supplied via line 201 to a floating common generator 300, a touch pad shield plate 460, a touch circuit 400, and a microcontroller 500. Oscillator 200 is described below with reference to FIG. 6.

Floating common generator 300 receives the 26 V peak square wave from oscillator 200 and outputs a regulated floating common that is 5 volts below the square wave output from oscillator 200 and has the same phase and frequency as the received square wave. This floating common output is supplied to touch circuit 400 and microcontroller 500 via line 301 such that the output square wave from oscillator 200 and floating common output from floating common generator 300 provide power to touch circuit 400 and microcontroller 500. Details of floating common generator 300 are discussed below with reference to FIG. 7.

Touch circuit 400 senses capacitance from a touch pad 450 via line 451 and outputs a signal to microcontroller 500 via line 401 upon detecting a capacitance to ground at touch pad 450 that exceeds a threshold value. The details of touch circuit 400 are described below with reference to FIG. 8.

Upon receiving an indication from touch circuit 400 that a sufficient capacitance to ground (typically at least 20 pF) is present at touch pad 450, microcontroller 500 outputs a signal to a load-controlling microcontroller 600 via line 501, which is preferably a two way optical coupling bus. Microcontroller 600 then responds in a predetermined manner to control a load 700. Having generally described the basic construction of the first embodiment, the preferred detailed construction of the depicted components will now be described with FIGS. 5-8. In cases where the number of lines to be switched is low, microcontroller 600 can be replaced by additional optical coupling lines. The number of lines to be switched will dictate whether it is more cost effective to multiplex over a two line optical bus such as line 501 and use a microcontroller to demultiplex, or to use a multiplicity of optical coupling lines. Other considerations such as reliability and power consumption may also affect this choice. In this preferred embodiment, the use of a single pair of optical coupling paths (line 501) and a microcontroller 600, is shown to emphasize the capability to switch a large number of lines.

A preferred circuit for implementing a voltage regulator 100 is shown in FIG. 5. Voltage regulator 100 preferably includes an AC/DC convertor 110 for generating 29 V to 36 V unregulated DC on line 119. This unregulated DC power is supplied to a 5 V DC regulator 120 and to a 26 V DC regulator 130. AC/DC convertor 110 includes diodes 112, 114, 116, and 118, which rectify the supplied 24 V AC power provided on power lines 101 and 102. The anode of the first diode 112 is coupled to power line 101 and to the cathode of the second diode 114. The cathode of the first diode 112 is coupled to output line 119. The anode of the second diode 114 is coupled to ground via line 103 and to the anode of the fourth diode 118. The anode of the third diode 116 is coupled to the cathode of the fourth diode 118 and to power line 102. The cathode of the third diode 116 is coupled to line 119 and to the cathode of the first diode 112. The anode of the fourth diode 118 is coupled to ground via line 103. Diodes 112, 114, 116, and 118 are preferably diodes having part no. 1N4002

available from LITEON. AC/DC convertor **110** also preferably includes a capacitor **115** for filtering the rectified output of the diodes. Capacitor **115** is preferably a 1000 μF capacitor coupled between output line **119** and ground via line **103**.

The 5 V regulator **120** preferably includes a 500 Ω resistor **122** coupled between line **119** and 5 V output line **104**, and a zener diode **124**, a first capacitor **126**, and second capacitor **128** all connected and parallel between output power lines **104** and **105**. Preferably, zener diode **124** is a 5.1 V zener diode having part no. 1N4733A available from LITEON, first capacitor **126** has a capacitance of 10 μF , and second capacitor **128** has a capacitance of 0.1 μF .

The 26 V regulator **130** preferably includes a transistor **134** having a collector connected to line **119** via a first resistor **132**, a base connected to line **119** via a second resistor **136**, and an emitter coupled to the regulated 26 V output power line **106**. The 26 V regulator **130** also preferably includes a capacitor **137** and zener diode **138** connected in parallel between the base of transistor **134** and ground line **103**. Preferably, first resistor **132** is a 20 Ω , 0.5 W resistor, second resistor **136** is a 1 k Ω , 0.5 W resistor, capacitor **137** is a 0.1 μF capacitor, and zener diode **138** is a 27 V, 0.5 W diode having part no. 1N5254B available from LITEON. It will be apparent to those skilled in the art, that various components of voltage regulator **100** may be added or excluded depending upon the source of power available to power the oscillator **200**. For example, if the available power is a 110 V AC 60 Hz commercial power line, a transformer may be added to convert the 110 V AC power to 24 V AC. Alternatively, if a DC battery is used, the AC/DC convertor among other components may be eliminated.

A preferred example of an 800 kHz oscillator is shown in FIG. 6. Oscillator **200** preferably includes a square wave generator **210**, which is powered by 5 V regulator **120** via lines **104** and **105**, for generating a 5 V peak square wave having the desired frequency, and a buffer circuit **230** powered by 26 V regulator **130** via line **106** for buffering the output of square wave generator **210** and boosting its peak from 5 V to 26 V while maintaining the preferred frequency. Square wave generator **210** is preferably an astable multivibrator constructed with at least two serially connected inverter gates **212** and **214**, and optionally, a third serially connected inverter gate **216**. Inverter gates **212**, **214** and **216** are preferably provided in a single integrated circuit designated as part 74HC04 available from National Semiconductor. The output of the first inverter gate **212** is coupled to its input via resistors **218** and **222** and is coupled to the output of the second inverter gate **214** via a capacitor **224**. The input of the second inverter gate **214** is directly connected to the output of the first inverter gate **212** and the output of the second inverter gate **214** is directly connected to the input of the optional third inverter gate **216**. To provide an 800 kHz output, resistor **218** preferably has a 10.0 k Ω value, resistor **222** preferably has a 1.78 k Ω value, and capacitor **224** is preferably a 220 pF capacitor.

The 5 V peak square wave generated by square wave generator **210** is supplied from either the output of inverter gate **214** or the output of optional inverter gate **216** to the base of a first transistor **238** via a first resistor **232** connected and parallel a capacitor **234**. The base of first transistor **238** is connected to the 26 V regulated DC power line **106** via a second resistor **236**. The collector of first transistor **238** is connected to 26 V power line **106** via a third resistor **240** and to the base of a second transistor **244**. The emitter of first transistor **238** is coupled to ground and to its own collector and the base of second transistor **244** via a fourth resistor **242**. The collector of the second transistor **244** is connected

directly to 26 V power line **106** and the emitter of second transistor **244** is connected to ground via a fifth resistor **246**. Second transistor **244** provides the 26 V peak square wave on output line **201**, which is connected to its emitter. In operation, the square wave signal applied to the base of transistor **238** causes the collector of transistor **238** to swing between near to the DC supply **106** voltage and the collector-emitter saturation voltage. Capacitor **234** is provided to improve the turning off of transistor **238**. Transistor **244** along with resistors **242** and **246** are used to buffer the square wave signal generated by transistor **238**. In a preferred embodiment, the values of the resistors and capacitor are as follows: first resistor **232** is 5.1 k Ω , capacitor **234** is 0.0047 μF , second resistor **236** is 1 M Ω , third resistor **240** is 1.6 k Ω , fourth resistor **242** is 100 k Ω , and fifth resistor **246** is 4.7 k Ω . Preferably, transistors **238** and **244** are those identified as part no. ZTX600 available from ZETEX. In this configuration, the oscillator **200** sources 80 mA to the floating common generator **300** such that together they supply a floating 5 V DC to power touch circuit(s) **400**, microcontroller **500**, and Schmitt triggered gates **420** (FIG. 8). As will be apparent to those skilled in the art, the values of the resistors and capacitors utilized in oscillator **200** may be varied from those disclosed above to provide for different oscillator output frequencies. As discussed above, however, oscillator **200** is preferably constructed so as to output a square wave having a frequency of 50 kHz or greater, and more preferably, of 800 kHz or greater. In some cases it may be necessary to use lower gain bandwidth product transistors or filtration to achieve a softer roll-off of the square edges to reduce high frequency noise emissions. When this is done the amplitude of the oscillator voltage can be increased to compensate.

The preferred construction of floating ground generator **300** is shown in FIG. 7 includes a zener diode **310** having a cathode connected to the oscillator output on line **201** and an anode connected to floating ground output line **301** and to ground via resistor **316** and diode **318**. Floating ground generator **300** also preferably includes a first capacitor **312** and a second capacitor **314** connected in parallel with zener diode **310**. In the preferred embodiment, zener diode **310** is a 5.1 V zener diode identified by part no. 1N4733A available from LITEON, capacitor **312** is a 47 μF tantalum capacitor, capacitor **314** is a 0.1 μF capacitor, resistor **316** is a 270 Ω resistor, and diode **318** is a diode identified as part no. 1N914B available from LITEON.

Touch circuit **400**, as shown in FIG. 8, preferably includes a transistor **410** having a base connected to touch pad **450** via resistor **413** and line **451**, an emitter coupled to oscillator output line **201**, and a collector coupled to floating ground line **301** via a pulse stretcher circuit **417**, which includes a resistor **416** and a capacitor **418** connected in parallel. To minimize susceptibility to noise, the physical length of the path between the touch pad **450** and the base of the transistor **410**, must be held to a minimum. Additionally, RC filters can be placed in line **401** between the output of the touch circuit **400** and the input of the microcontroller **500** to give additional EMI/RFI immunity. Additionally, the higher the frequency, the higher the gain bandwidth product that is required in transistor **410**. The gain bandwidth product must be sufficient to guarantee that the oscillator turns on during oscillator High pulses. A further trade-off is to use higher gain bandwidth product to allow lower oscillator voltages or higher oscillator voltages to all allow a lower gain bandwidth product transistor to be used. The combination of oscillator voltage, frequency and transistor gain bandwidth product that is used will necessarily vary with the cost.

15

safety and reliability requirements of a given application. The present combination was chosen to keep the oscillator voltage down and allow operation at 800 kHz to minimize cross talk. At higher frequencies a higher gain bandwidth product transistor would be required in both the oscillator 200 and detection 400 circuits. Touch circuit 400 also preferably includes resistor 412 and a diode 414 having an anode connected to the base of transistor 410 and to resistor 413, and a cathode connected to the emitter of transistor 410 and to a resistor 412 connected in parallel with diode 414 between the base and emitter of transistor 410. The pulse stretcher circuit 417 is identified as such because the sensitivity of the touch circuit may be increased or decreased by varying the resistance of resistor 416. The base of transistor 410 is connected via resistor 413 to line 451 connected to touch pad 450.

Additionally, touch circuit 400 may include at least one Schmitt triggered gate 420 powered by the voltage difference existing between oscillator line 201 and 301, and having an input terminal coupled to the collector of transistor 410 and an output coupled to microcontroller 500 via output line 401. Schmitt triggered inverter gate 420 is optionally provided to improve the rise time of the touch switch output and to buffer the output. Preferably, transistor 410 is part no. BC858CL available from Motorola, resistor 412 is a 12 M Ω resistor, diode 414 is part no. 1N914B available from Diodes, Inc., resistor 416 is a 470 k Ω resistor, capacitor 418 is a 0.001 μ F capacitor, and resistor 413 is a 10 k Ω resistor.

As stated above, the operator's body includes a capacitance to ground, which may range in a typical person from between 20 to 300 pF. The base terminal of transistor 410 is coupled to its emitter by resistor 412 such that unless capacitance is present by the user touching the touch pad 450, transistor 410 will not be forward biased and will not conduct. Thus, when touch pad 450 is not touched, the output signal at the collector terminal of transistor 410 and across pulse stretcher circuit 417 will be zero volts. When, however, a person touches the touch pad 450, that person's body capacitance to ground couples the base of transistor 410 to ground 103 through resistor 413, thereby forward biasing transistor 410 into conduction. This charges capacitor 418 providing a positive DC voltage with respect to the line 301 and causes the output of the Schmitt trigger 420 to go low. Diode 414 is coupled across the base to emitter junction of transistor 410 to clamp the base emitter reverse bias voltage to -0.7 V and also reduce the forward recovery and turn-on time.

Touch pad 450 includes a substrate on which a plurality of electrically conductive plate members are mounted on one surface thereof. The substrate is an insulator and the plates are spaced apart in order to insulate the plates from one another and from ground. Also, positioned on the substrate is a guard band, generally shown as 460. Guard band 460 is a grid of conductor segments extending between adjacent pairs of plate members. All conductor segments are physically interconnected to define a plurality of spaces with one plate member positioned centrally within each space. Components of the touch circuit may be positioned on the side of substrate opposite plate members and guard band 460.

A planar dielectric member is spaced from the substrate facing plate members. The dielectric member is made from a non-porous insulating material such as polycarbonate or glass. A plurality of electrically conductive spring contacts are sandwiched between the inner surface of the dielectric member and the substrate. An indicia layer may be adhered to the inner surface of the dielectric member to provide an indication of the function of each input portion.

16

As mentioned above, interface between the dielectric member and a conductive plate is a metallic spring contact that is attached to the back of the dielectric member. The spring contacts offer advantages at high temperature extremes. However, for sufficiently narrow temperature ranges, conductive polymer foam pads cut to the size of the touch pads are preferably used to fill the gap between conductive pad and dielectric layer. The function of the spring contacts or conductive foam pads is to eliminate that capacitive contribution of the air filled gap between the conductive pads and the overlying dielectric layer.

A problem with capacity responsive keyboards is the tendency of switches that are closely positioned in a keyboard system to inadvertently become actuated even though the user is touching an adjacent switch. Furthermore, this problem is greatly aggravated by the presence of contamination on the outer surface of dielectric member. Contamination such as skin oil or moisture causes erratic keyboard operation and multiple switches will turn on even though one switch is touched. By operating at a high frequency such as 100 kHz or 800 kHz, the impedance of the series combination of body and glass capacitance are lowered as compared to the impedance of contamination present on the glass thereby reducing crosstalk.

If glass thickness is smaller than $\frac{3}{16}$ inch, the touch circuit becomes more sensitive to body capacitance. There are two ways to adjust the sensitivity so that crosstalk does not occur: remove diode 414 and/or reduce the resistance of resistor 416. Increasing the resistance of resistor 416 would allow usage of thicker glass. However, this resistance preferably should not go above 750 k Ω . This is because of the maximum low input voltage of 0.8 V and input leakage current of 1 μ A at the Schmitt trigger gate 420.

The oscillator circuitry shown in FIG. 6 is very stable over the temperature range of -40 $^{\circ}$ C. to 105 $^{\circ}$ C. The output of the touch switch circuitry drops at a rate of approximately 40 mV/ $^{\circ}$ C. when temperature falls below 0 $^{\circ}$ C. If application requires operation at low temperatures (-40 $^{\circ}$ C.), the following three methods may be used to increase the output of the switch: increase the oscillator's regulated supply voltage, increase the resistance of resistor 416, and use a higher gain transistor 410. All of these methods would increase sensitivity at high temperatures. Another way to correct this problem is to use a thermistor to vary the regulated supply voltage as a function of temperature.

Since the input power is regulated down to 26 V DC, variation of power (24 V AC \pm 10% or 29 V DC to 36 V DC) does not affect circuit operation. Table 3 below shows the measured output voltage of the switch for various supply voltages.

TABLE 3

SUPPLY VOLTAGE	SWITCH OUTPUT
36 VDC	4.96 V
35 VDC	4.96 V
34 VDC	4.95 V
33 VDC	4.95 V
32 VDC	4.94 V
31 VDC	4.93 V
30 VDC	4.93 V
29 VDC	4.92 V

$$PSRR=6 \text{ mV/V}=-45 \text{ dB}$$

In order to determine the effect of body capacitance on circuit operation, the circuit of FIG. 3 was used to simulate glass, water resistance, and body capacitance. The following two conditions were simulated and tested:

- 1—The maximum body capacitance that does not cause crosswalk when:
 Temperature=105° C.
 Supply Voltage=36VDC
 Glass Capacitance=2 pF
 Water Resistance=330 k to 1 MΩ
 - 2—The minimum capacitance to turn on a switch when:
 Temperature=0° C.
 Supply Voltage=29VDC
 Glass Capacitance=2 pF
 - 3—Operation at room temperature.
- Table 4 below shows the signal and noise voltages at the switch output for different values of body capacitance and contamination resistance.

TABLE 4

CONTAMINATION RE-SISTANCE	BODY CAPACITANCE				
	20 pF	220 pF	330 pF	550 pF	1230 pF
330 kΩ	S: 5.1 V N: 2.0 V	S: 5.1 V N: 4.0 V	S: 5.1 V N: 4.5 V	S: 5.1 V N: 4.9 V	S: 5.1 V N: 5.0 V
500 kΩ	S: 5.1 V N: 0.2 V	S: 5.1 V N: 0.6 V	S: 5.1 V N: 0.7 V	S: 5.1 V N: 0.8 V	S: 5.1 V N: 0.8 V
1 MΩ (Condensed Water)	S: 5.1 V N: 0.1 V	S: 5.1 V N: 0.1 V	S: 5.1 V N: 0.1 V	S: 5.1 V N: 0.1 V	S: 5.1 V N: 0.1 V
NONE	S: 5.1 V N: 10 mV	S: 5.1 V N: 10 mV	S: 5.1 V N: 10 mV	S: 5.1 V N: 10 mV	S: 5.1 V N: 10 mV

S = Signal (TOUCH)
 N = Noise (NO TOUCH)
 supply voltage = 36 VDC
 temperature = 105° C.

With contamination resistance of 1 MΩ or more, the circuit is insensitive to body capacitance variations and has a minimum signal-to-noise ratio of -34 dB. With no contamination, signal-to-noise ratio is approximately -54 dB. The graph in FIG. 9 shows the signal-to-noise ratio versus body capacitance, for different values of contamination resistance at 105° C. The minimum body capacitance to turn on a switch is 20 pF.

At room temperature, crosstalk decreases because of gain drop of transistor 410. Table 5 below shows that at room temperature, the circuit rejects 250 kΩ of contamination, independent of body capacitance. Below 250 kΩ, body capacitance will affect crosstalk.

TABLE 5

CONTAMINATION RE-SISTANCE	BODY CAPACITANCE				
	20 pF	220 pF	330 pF	550 pF	1230 pF
200 kΩ	S: 5.1 V N: 0.2 V	S: 5.1 V N: 1.0 V	S: 5.1 V N: 1.2 V	S: 5.1 V N: 1.8 V	S: 5.1 V N: 2.2 V
250 kΩ	S: 5.1 V N: 0.1 V	S: 5.1 V N: 0.1 V	S: 5.1 V N: 0.5 V	S: 5.1 V N: 0.5 V	S: 5.1 V N: 0.5 V
330 kΩ	S: 5.1 V N: 0.1 V	S: 5.1 V N: 0.1 V	S: 5.1 V N: 0.1 V	S: 5.1 V N: 0.1 V	S: 5.1 V N: 0.1 V
1 MΩ (Condensed Water)	S: 5.1 V N: 0.1 V	S: 5.1 V N: 0.1 V	S: 5.1 V N: 0.1 V	S: 5.1 V N: 0.1 V	S: 5.1 V N: 0.1 V

S = Signal (TOUCH)
 N = Noise (NO TOUCH)
 supply voltage = 36 VDC
 temperature = 25° C.

The graph of FIG. 10 shows the measured signal-to-noise ratio versus body capacitance, for different contamination resistance values at room temperature.

The particular advantages of the preceding circuit over that of existing touch detection circuits such as that disclosed in U.S. Pat. No. 4,758,735, are the use of diode 414 (selected for high speed) to minimize forward recovery time rather than merely provide reverse polarity protection (as with the slower type of diode used in the existing circuits) and the omission of a capacitor coupled across the base to emitter junction of the detection transistor 410 to make the circuit more sensitive and operable with a lower oscillator amplitude and higher oscillator frequency. These features along with appropriate choices in component values make possible operation at significantly higher frequencies (>50 to 800 kHz) than are seen in existing art (60 to 1000 Hz). At frequencies at or near 800 kHz, the 20-300 pF of capacitance to ground offered by the human body presents a considerably lower impedance than the primarily resistive impedance of skin oil or water films that may appear on the dielectric layer overlying the conductive touch pads. This allows the peak voltage of a pad that is touched to come considerably closer to ground than adjacent pads which will have a voltage drop across any contaminating film layer that is providing a conductive path to the area that is touched. The enhanced sensitivity offered by the omission of any capacitor between the base and emitter of the detection transistor 410, allows the threshold of detection to be set much closer to ground than would be the case otherwise. This allows discrimination between the pad that is touched and adjacent pads that might be pulled towards ground via the conductive path to the touch formed by a contaminating film. This high frequency regime of operation offers a considerable advantage relative to the existing art in terms of immunity to surface contaminants such as skin oil and moisture.

A multiple touch pad circuit constructed in accordance with the second embodiment is shown in FIG. 11. In the second embodiment of FIG. 11, components similar to those in the first embodiment in FIG. 4 are designated with the same reference numerals and will not be discussed in detail. The multiple touch pad circuit is a variation of the first embodiment in that it includes an array of touch circuits designated as 900₁ through 900_{nm}, which, as shown, include both the touch circuit 400 shown in FIGS. 4 and 8 and the input touch terminal pad 451 (FIG. 4). Microcontroller 500 selects each row of the touch circuits 900₁ to 900_{nm} by providing the signal from oscillator 200 to selected rows of touch circuits. In this manner, microcontroller 500 can sequentially activate the touch circuit rows and associate the received inputs from the columns of the array with the activated touch circuit(s). To keep the path length 451 between the touch pad 450 and the base to the detection transistor 410 to a minimum, the detection circuits 900 are physically located directly beneath the touch pads. To simplify assembly, a flexible circuit board such as vended by Sheldahl, Inc. or Circuit Etching Technics, Inc. can be used for this purpose. Ideally, the printed circuit will be fixed directly against the surface (typically glass) bearing the conductive touch pads to eliminate air gaps and the need for conductive foam pads and spring contacts which were used to fill air gaps.

For this second embodiment, the oscillator 200 of the first embodiment may be slightly modified from that shown in FIG. 6 to include a transistor (not shown) coupled between the oscillator output and ground with its base connected to microcontroller 600 such that microcontroller 600 may selectively disable the output of oscillator 200.

The use of a high frequency in accordance with the present invention provides distinct advantages for circuits

such as the multiple touch pad circuit of the present invention due to the manner in which crosstalk is substantially reduced without requiring any physical structure to isolate the touch terminals. Further, the reduction in crosstalk afforded by the present invention, allows the touch terminals in the array to be more closely spaced together.

A third embodiment of the present invention, which provides touch circuit redundancy, is described below with reference to FIGS. 12-14. As shown in FIG. 12, the switching circuit according to the third embodiment includes a voltage regulator 1100 for regulating power supplied by 24 V DC power lines 1101 and 1102 with ground connection 1103, for supplying the regulated power to an oscillator 1200 via lines 1104 and 1107.

Oscillator 1200 supplies a continuous and periodic signal to touch circuits 1400a and 1400b via line 1201. Preferably, the frequency of the oscillator output signal is at least 100 kHz, and more preferably, at least 800 kHz. The two touch circuits 1400a and 1400b are identical in construction and both receive the output of touch terminal 1450 via line 1451. A detailed description of the preferred voltage regulator circuit 1100, oscillator 1200, and touch circuits 1400a and 1400b is provided below with reference to FIG. 13 following the description of the remaining portion of the third embodiment.

The output of the first touch circuit 1400a is supplied to a first driver circuit 1500 via line 1401a while the output of the second touch circuit 1400b is supplied to a second driver circuit 1600 via line 1401b. The two driver circuits 1500 and 1600 are provided to drive first and second serially connected switching transistors 1700 and 1710. The switching transistors 1700 and 1710 must both be conducting to supply power to a relay switch 1800. Thus, if one of touch circuits 1400a and 1400b does not detect a touch of touch terminal 1450, one of switching transistors 1700 and 1710 will not conduct and power will not be supplied to relay switch 1800. The preferred construction of driver circuits 1500 and 1600 and relay switch 1800 are described below with reference to FIG. 14.

As shown in FIG. 13, voltage regulator 1100 may be constructed by providing a first capacitor 1110 and a varistor 1112 connected in parallel across input power terminals 1101 and 1102. Preferably, return power terminal 1102 is connected via line 1103 to ground. Varistor 1112 is used to protect the circuit for over-voltage conditions. Also connected in parallel with first capacitor 1110 and varistor 1112, are the serially connected combination of a fuse 1114, a diode 1116, a resistor 1118 and two parallel connected capacitors 1120 and 1122. The voltage regulator 1100 is reverse polarity protected by diode 1116 and current limited by resistor 1118. Capacitors 1120 and 1122 provide filtering.

Voltage regulator 1100 further includes a zener diode 1128 having its cathode connected to a node between resistor 1118 and capacitors 1120 and 1122 and to output power line 1104. The anode of zener diode 1128 is coupled to output power common line 1107 and to ground line 1103 via two serially connected resistors 1124 and 1126. Zener diode 1128 and resistors 1124 and 1126 generate regulated 15 V DC. Two capacitors 1130 and 1132 are connected in parallel with zener diode 1128 between power lines 1104 and 1107. Capacitors 1130 and 1132 provide filtering and decoupling, respectively. Preferably, capacitor 1110 has a capacitance of 1000 pF, 1000V, varistor 1112 is part no. S14K25 available from Siemens, fuse 1114 is a ¼A fuse, diode 1116 is part no. 1N4002 available from LITEON, resistor 1118 has a resistance of 10Ω, ½W, capacitor 1120 has a capacitance of 22 μF, 35V, capacitor 1122 has a

capacitance of 0.1 μF, zener diode 1128 is part no. 1N4744A available from LITEON, resistor 1124 has a resistance of 220Ω, resistor 1126 has a resistance of 220Ω, capacitor 1130 has a capacitance of 1 μF, 25V, and capacitor 1132 has a capacitance of 0.1 μF.

Oscillator 1200 is preferably comprised of a first inverter gate 1210 having its input coupled to its output via resistors 1214 and 1216, and a second inverter gate 1212 having its input coupled to the output of first inverter gate 1210 and its output coupled to its input via a capacitor 1218 and resistor 1216. The oscillating output of the second inverter gate 1212 is buffered via transistor 1226, which has its base connected to the output of second inverter gate 1212 via resistor 1220 and capacitor 1222, which are connected in parallel therebetween. The base of transistor 1226 is also coupled to power line 1104 via a resistor 1224. The emitter of transistor 1226 is connected to power line 1104 and the collector is connected to power line 1107 via a resistor 1230, to the anode of a diode 1228, and to the oscillator output line 1201. Diode 1228 has its cathode connected to power line 1104 and is used to protect transistor 1226.

Preferably, inverter gates 1210 and 1212 are provided by part no. CD40106B available from Harris, resistor 1214 has a resistance of 10 kΩ, resistor 1216 has a resistance of 1.18 kΩ, 1%, capacitor 1218 has a capacitance of 220 pF, resistor 1220 has a resistance of 4.7 kΩ, capacitor 1222 has a capacitance of 220 pF, resistor 1224 has a resistance of 100 kΩ, transistor 1226 is part no. MMBTA70L available from Motorola, diode 1228 is part no. RLS4448 available from LITEON, and resistor 1230 has a resistance of 3.3 kΩ.

Two touch circuits 1400a and 1400b are provided in parallel to provide redundancy so that if one fails, the relay drivers are disabled. Because the touch circuits 1400a and 1400b are identical, only one of the touch circuits will now be described. Touch circuit 1400a preferably includes two resistors 1410a and 1412a coupled in series between touch terminal output line 1451 and the base of a bipolar PNP transistor 1420a. Transistor 1420a has its emitter connected to the oscillator output line 1201 and its collector connected to power common line 1107 via a resistor 1422a. Touch circuit 1400a further includes a diode 1414a, a capacitor 1416a, and a resistor 1418a all connected in parallel between the base of transistor 1420a and the emitter thereof, which is connected to oscillator output line 1201. Touch circuit 1400a also includes a diode 1424a having its anode connected to the collector of transistor 1420a and its cathode connected to touch circuit output line 1401a via a resistor 1426a.

Preferably, resistor 1410a has a resistance of 5.1 kΩ, resistor 1412a has a resistance of 5.1 kΩ, diode 1414a is part no. RLS4448 available from LITEON, capacitor 1416a has a capacitance of 240 pF, resistor 1418a has a resistance of 12 MΩ, transistor 1420a is part no. BC857CL available from Motorola, resistor 1422a has a resistance of 100 kΩ, diode 1424a is part no. RLS4448 available from LITEON, and resistor 1426a has a resistance of 100 kΩ.

The preferred detailed construction of the first and second driver circuits 1500 and 1600 will now be described with reference to FIG. 14. In first driver circuit 1500, the output line 1401a of first touch circuit 1400a is connected to power common line 1107 via a resistor 1510 and also via a capacitor 1512 connected in parallel therewith. The output line 1401a is also connected to the inverting input terminal of an operational amplifier 1514. The non-inverting input terminal of operational amplifier 1514 is connected to line 1502, which runs between first and second driver circuits

1500 and 1600 and is connected to power line 1104 via a resistor 1626. The output of op amp 1514 is connected to power line 1104 via a resistor 1518 and to the input of a Schmitt trigger inverter gate 1516. The output of Schmitt trigger inverter gate 1516 is connected to the input of a second Schmitt trigger inverter gate 1526 via a resistor 1520. A diode 1522 is connected in parallel with resistor 1520 with its cathode connected to the output of inverter gate 1516 and its anode connected to the input of inverter gate 1526 and to power common line 1107 via capacitor 1524. The output of inverter gate 1526 is connected to the base of bipolar PNP switching transistor 1700 via a resistor 1528. The base of transistor 1700 is also connected to power common line 1107 via a capacitor 1532 and to power line 1104 and its emitter via a resistor 1530.

Preferably, resistor 1510 has a resistance of 10 M Ω , capacitor 1512 has a capacitance of 0.01 μ F, op amp comparator 1514 is part no. LM393 available from National Semiconductor, inverter gate 1516 is part no. CD40106B available from Harris, resistor 1518 has a resistance of 10 k Ω , resistor 1520 has a resistance of 1 M Ω , diode 1522 is part no. RLS4448 available from LITEON, capacitor 1524 has a capacitance of 0.22 μ F, inverter gate 1526 is part no. CD40106 available from Harris, resistor 1528 has a resistance of 12 k Ω , resistor 1530 has a resistance of 100 k Ω , capacitor 1532 has a capacitance of 0.01 μ F, and transistor 1700 is part no. MMBTA56L available from Motorola.

In second driver circuit 1600, the output line 1401b of second touch circuit 1400b is connected to power common line 1107 via a resistor 1610 and also via a capacitor 1612 connected in parallel therewith. The output line 1401b is also connected to the inverting input terminal of an operational amplifier 1614. The non-inverting input terminal of operational amplifier 1614 is connected to line 1502, which is connected to power line 1104 via resistor 1626. The non-inverting input terminal of op amp 1614 is also connected to power common line 1107 via a capacitor 1616 and a resistor 1618, which are connected in parallel. The output of op amp 1614 is connected to power line 1104 via a resistor 1630 and to the coupled inputs of a Schmitt trigger inverter gate 1628. The output of op amp 1614 is also connected to its non-inverting input terminal via a resistor 1624. The output of Schmitt trigger inverter NAND gate 1628 is connected to the input of a second Schmitt trigger inverter gate 1638 via a resistor 1632. A diode 1634 is connected in parallel with resistor 1632 with its cathode connected to the output of inverter NAND gate 1628 and its anode connected to the input of inverter NAND gate 1638 and to power common line 1107 via a capacitor 1636. The output of inverter gate 1638 is connected to the base of switching bipolar PNP transistor 1710 via a resistor 1640. The base of transistor 1710 is also connected to power common line 1107 via a capacitor 1642 and to power line 1104 via a resistor 1644. Second driver circuit 1600 also preferably includes capacitors 1620 and 1622 connected in parallel between its connections to power lines 1104 and 1107.

Preferably, resistor 1610 has a resistance of 10 M Ω , capacitor 1612 has a capacitance of 0.01 μ F, op amp comparator 1614 is part no. LM393 available from National Semiconductor, capacitor 1616 has a capacitance of 0.01 μ F, resistor 1618 has a resistance of 20 k Ω , capacitor 1620 has a capacitance of 0.1 μ F, capacitor 1622 has a capacitance of 0.1 μ F, resistor 1624 has a resistance of 100 k Ω , resistor 1626 has a resistance of 10 k Ω , inverter NAND gate 1628 is part no. CD4093B available from Harris, resistor 1630 has a resistance of 10 k Ω , resistor 1632 has a resistance of 1 M Ω , diode 1634 is part no. RLS4448 available from

LITEON, capacitor 1636 has a capacitance of 0.22 μ F, inverter NAND gate 1638 is part no. CD4093B available from Harris, resistor 1640 has a resistance of 12 k Ω , capacitor 1642 has a capacitance of 0.01 μ F, resistor 1644 has a resistance of 100 k Ω , and transistor 1710 is part no. MMBTA56L available from Motorola.

In operation, the output of transistor 1420a (FIG. 13) taken at its collector is rectified by diode 1424a and a DC level is generated by resistors 1426a and 1510 and capacitor 1512 (a DC level of the output of transistor 1420b is generated by resistors 1426b and 1610 and capacitor 1612). When this DC level exceeds the upper threshold voltage of op amp comparator 1514 (1614), the output of schmitt triggered inverter gate 1516 inverter NAND gate 1628 (1628) goes high which charges capacitor 1524 (1636) through resistor 1520 (1632). Gates 1516 and 1526 (1628 and 1638), resistor 1520 (1632), and capacitor 1524 (1636) provide debounce in a conventional manner. Diode 1522 (1634) is used to provide fast release when the palm of the hand is removed from the touch terminal 1450. The output of the debounce circuitry drives transistor 1700 (1710). Resistor 1528 (1640) and capacitor 1532 (1642) are used to filter noise. Both touch circuits must be functional in order to drive the relay switch 1800. Also, if one of the transistors 1700 or 1710 fails, the relay will not be activated.

Relay switch 1800 may be any conventional relay. An example of such a relay is shown in FIG. 14. Relay switch 1800 may include a relay coil 1810 coupled between the selective power supply 1711 of transistors 1700 and 1710 and ground, and a pair of magnetically responsive switches that switch from normally closed terminals 1805 and 1807 to normally open terminals 1801 and 1803 when the relay coil is energized. A zener diode 1815 may be placed in series with a diode 1820 to reduce stress on the relay coil 1810 and to protect transistor 1710 when transistors 1700 and 1710 switch off.

Although the touch circuits of the third embodiment are disclosed as operating a relay switch via driver circuits, it will be appreciated by those skilled in the art that the outputs of touch circuits 1400a and 1400b could be supplied to a microcontroller in the manner discussed above with respect to the first embodiment.

The palm button switch of the present invention uses two redundant touch switch circuits, such as shown in FIG. 12, to disable relay drivers if one of the touch switch circuits fails and redundant relay driver circuitry to turn off a relay switch if one of the driver circuits fails.

Alternatively, the circuitry shown in FIG. 4 could be used. In another embodiment a method to prevent inadvertent actuations is to require a multi-step process. Referring to FIG. 19, a device is shown having a first palm button 2201, a second palm button 2202, and an indicator light 2205. Palm button 2201 has to be activated first and then button 2202 has to be activated within a 2 second time window before a desired actuation can occur. The 90 degree orientation of the two buttons makes it extremely difficult to accidentally touch both with an arm and an elbow or other such physical combination. An added advantage is that the motion required to move the hand from button 2201 to button 2202 can provide some relief from fatigue in the forearm by the resulting muscle flexure that would otherwise not occur if the hand had to be kept near a single button for extended periods of time. A further redundancy can be achieved by requiring simultaneous operation of two such devices, one for each hand. This provides further safeguards against inadvertent actuations and forces the operator to have both hands in a desired safe location once a desired

actuation occurs. A further option is to provide one or more LEDs 2205 or audible annunciators for visual or audible feedback to the operator. Specifically, in FIG. 19 the LED 2205 will come on when button 2201 has been successfully activated to cue the operator that it is time to move to button 2202. Where required a second LED with a different color than the first (yellow for the first LED and red for the second) can be provided to provide visual confirmation that the second button 2202 has been activated or that the required combination of the two buttons has been activated. Two different audible tone or sound generators could also be used in lieu of the LEDs to provide feedback to the operator. In industrial or other challenging settings, the housing is made of high strength polycarbonate (or other high strength non-metallic material) to meet high impact and vibration requirements, preferably NEMA 4. A further option is to provide lighting for the switches to allow operation in the dark.

In a variation of the multi-step process, two touch plates within a housing (one vertical and one horizontal) are used to provide a two-step turn-on. Referring to FIGS. 20A-C, the first step to actuate the output relay 2310, is initiated when the operator inserts his hands and touches the vertical touch sensor 2301 with the dorsal side of the hands. A yellow LED 2304 on top of the device show the successful completion of the first step. The second step is to flip the hand over and touch the horizontal touch sensor 2302 with the palmar side of the hand. A red LED 2305 on top of the device shows the completion of the two step turn-on and activation of output relay 2310. The flipping action of the hand in the second step causes the forearm muscles to flex, thereby reducing stiffness and fatigue. Also, the hands, and arms can rest on the run bar until the machine cycle is complete. The second step of the two-step turn-on must occur within some predetermined time (for example 2 seconds) after the release of vertical touch sensor or the first step must be repeated. In this proposed embodiment, the second step provides an added stimulus and reduces operator errors due to mental and physical fatigue. The top cover prevents actuation of two devices by the use of one hand and elbow of the same arm, as required by ANSI Standard B11.19-1990. The enclosure must be a high strength polycarbonate module to meet the high impact and vibration requirements of the industry, preferably NEMA 4. In both embodiments, high frequency switching is used to desensitize the unit against moisture and contaminants that could generate a path between the button and grounded chassis. The palm button may be formed as the flat palm button shown in FIGS. 15A-C or as a dome-shaped palm button shown in FIG. 16. The button is made of a brass plate 1910 (1930) and can be covered with a plastic or glass 1925 (1933) cover or membrane to desensitize the unit even more against contaminants and other inadvertent actuation. The plastic cover 1925 (1933) acts as a dielectric and capacitance is varied as a function of the area of the plastic being touched. Therefore, if button is touched by finger, a much smaller series capacitance is generated as opposed to button being touched by the palm of a hand. This capacitance is placed in series with the capacitance of the body to ground when the button is touched. Since the capacitance of the body to ground is much larger than the capacitance generated by the button, the functionality of the unit is independent of the variations in body capacitance to ground from person to person. The other factor that needs to be considered here is body resistance. If the button is not covered with an insulator such as plastic, the unit would become sensitive to body resistance. Body resistance to ground, changes as a function of moisture in the work area,

skin dryness, floor structure, and shoes. By using a plastic cover, the unit is made insensitive to variations of body resistance and capacitance. The shape of the button is also a factor in sensitivity. If the button is flat, less of the button area would be covered by the palm of the hand as opposed to a dome shape button that matches the contour of the palm. Therefore, if the button is dome-shaped, the unit can be even more desensitized against inadvertent operation.

By providing a large space for hand insertion and switch activation and a flat or dome shape button where the palm of the hand rests while machine cycle is in process, stress on the forearms is ergonomically reduced. The palm button of the present invention can be activated with or without gloves. The zero force palm button of the present invention may be used to activate electric, pneumatic, air clutch, and hydraulic equipment such as punch presses, molding machines, etc.

As shown in FIGS. 15A-C, the flat palm button may include a plastic housing 1917 having an optional metallic enclosure 1922 for surface mounting. The button also may include a flush mount surface 1915 and optional guarding 1920.

The circuit board 1935 used with the palm button of the present invention may be packaged on two printed circuit boards. One board for power and relay and the other for touch switches and relay drivers. The touch circuit on the touch switch board is interfaced to the button through a screw that also holds the button in place. The power/relay board is interfaced to the touch switch board through a three pin right angle connector. Wiring to the unit is done through a seven position terminal block on the power/relay board. The power/relay board is designed for 24 V DC input power and provides two double-throw relay contacts. However, it can be modified to accommodate different power inputs and switch outputs. For example, a transformer may be added to the power board so that the unit is powered 110VAC/220VAC instead of 24 V DC. Also, the relays may be replaced with other outputs such as digital or 4-20 mA outputs.

The touch circuit components can be integrated in a custom IC 2000, as shown in FIG. 17, to facilitate manufacturing and to reduce cost. Components 413, 412, 414, 410, 418, and 420 are similar to those of circuit 400 shown in FIG. 8. Preferably, resistor 2004 has a resistance of 470 k Ω and diode 2002 has characteristics similar to part no. 1N4148 available from LITEON. Resistors 2008 and 2006 are used to adjust the sensitivity. Diode 2002 at the output of 420, allows the IC to be used in applications where several touch circuit IC's are multiplexed.

As shown in FIG. 18, a sleep circuit 2100 may be added to the oscillator circuit 200 (FIG. 6) to allow microcontroller 600 to turn off the oscillator circuit 200. The disabling of oscillator circuit 200 is done to reduce drainage of capacitor 126 in the regulator circuit 120 during brown outs. The circuit diagram shown in FIG. 18 is a modified version of circuit 200 in FIG. 6. During normal operation microcontroller 600 pulls the input of gate 2116 to ground and causes the output of gate 2116 to go high (power line 104). Therefore, transistor 2110 is biased on and oscillator 200 is functional. When in a sleep mode, microcontroller 600 sources the input to gate 2116 high and causes the output of gate 2116 to go low which turns off transistor 2110 and pulls the input of gate 212 low. Therefore, the oscillator will stop oscillating and drainage on capacitor 126 decreases considerably.

The above described embodiments were chosen for purposes of describing but one application of the present

25

invention. It will be understood by those who practice the invention and by those skilled in the art, that various modifications and improvements may be made to the invention without departing from the spirit or scope of the invention as defined by the appended claims.

The embodiments of the invention in which an exclusive property or privilege is claimed are defined as follows:

1. A capacitive responsive electronic switching circuit comprising:

an oscillator providing a periodic output signal having a frequency of 50 kHz or greater;

an input touch terminal having a dielectric cover defining an area for an operator to provide an input by proximity and touch, an operator's body capacitance to ground as sensed through said input touch terminal varying as a function of the area of said input touch terminal that is proximate the operator's body; and

a detector circuit coupled to said oscillator for receiving said periodic output signal from said oscillator, and coupled to said input touch terminal, said detector circuit being responsive to signals from said oscillator and the presence of an operator's body capacitance to ground coupled to said touch terminal when proximal or touched by an operator to provide a control output signal, wherein said detector circuit includes means for generating said control signal when the sensed body capacitance to ground exceeds a threshold level in order to prevent unintended activation based upon an operator's inadvertent proximity and touch with said input touch terminal.

2. The switching circuit as defined in claim 1, wherein said oscillator provides a periodic output signal having a frequency of 800 kHz or greater.

3. The switching circuit as defined in claim 1 and further including a DC power supply for supplying power to said oscillator and a ground.

4. The switching circuit as defined in claim 1, wherein said periodic output signal provided by said oscillator is a square wave output signal, said oscillator includes a square wave generator for generating a square wave, and a plurality of active elements coupled to an output of said square wave generator to buffer and improve the shape of the square wave output therefrom.

5. The switching circuit as defined in claim 1, wherein said detector circuit includes a microcontroller and a charge pump circuit coupled between said input touch terminal and said microcontroller.

6. The switching circuit as defined in claim 1, wherein said detector circuit includes a microcontroller and a touch circuit coupled between said input touch terminal and said microcontroller.

7. The switching circuit as defined in claim 6 and further including a plurality of said input touch terminals and a plurality of said touch circuits respectively associated with said input touch terminals.

8. The switching circuit as defined in claim 7, wherein said microcontroller selectively applies said periodic output signals received from said oscillator to each of said touch circuits to separately activate each touch circuit.

9. A capacitive responsive electronic switching circuit comprising:

an oscillator providing a periodic output signal having a frequency of 50 kHz or greater;

an input touch terminal defining an area for an operator to provide an input by proximity and touch;

a detector circuit coupled to said oscillator for receiving said periodic output signal from said oscillator, and

26

coupled to said input touch terminal, said detector circuit being responsive to signals from said oscillator and the presence of an operator's body capacitance to ground coupled to said touch terminal when proximal or touched by an operator to provide a control output signal; and

a floating common generator coupled to said oscillator for receiving said square wave output signal, said floating common generator generating a floating common reference for said detector circuit that is set at a fixed voltage below and tracks the square wave output signal.

10. The switching circuit as defined in claim 9, wherein said detector circuit is powered by said square wave output signal provided by said oscillator and by said floating common reference provided by said floating common generator thereby increasing the sensitivity of said detector circuit to proximity and touching of said touch terminal by an operator's body.

11. The switching circuit as defined in claim 10, wherein said detector circuit includes a microcontroller and a charge pump circuit coupled between said input touch terminal and said microcontroller, by an operator's body, wherein said charge pump circuit includes at least one high speed diode coupled between said oscillator and said touch terminal, for enhancing a sensitivity at which said charge pump responds to sensed body capacitance at said touch terminal for higher frequencies.

12. A proximity and touch controlled switching circuit comprising:

an oscillator providing a square wave output signal having a frequency of 50 kHz or greater;

a touch terminal having a dielectric cover defining an input terminal for coupling to an operator's body capacitance to ground; and

a charge pump circuit coupled to said oscillator for receiving said square wave output signal, and coupled to said touch terminal, said charge pump circuit having an output terminal that supplies an output signal having a voltage that varies when said touch terminal is proximal or touched by an operator's body, the voltage of said output signal varies as a function of the area of said touch terminal that is proximal or touched by an operator,

wherein said charge pump circuit includes at least one high speed diode coupled between said oscillator and said touch terminal, for enhancing a sensitivity at which said charge pump responds to sensed body capacitance to ground at said touch terminal for higher frequencies.

13. The proximity and touch controlled circuit as defined in claim 12 and further including a DC power supply for supplying power to said oscillator and a ground.

14. The proximity and touch controlled circuit as defined in claim 12, wherein said oscillator includes a square wave generator for generating a square wave, and a plurality of active elements coupled to an output of said square wave generator to buffer and improve the shape of the square wave output therefrom.

15. The proximity and touch controlled circuit as defined in claim 12, wherein said oscillator provides a periodic output signal having a frequency of 800 kHz or greater.

16. A proximity and touch controlled switching circuit comprising:

an oscillator providing a square wave output signal having a frequency of 50 kHz or greater;

a touch terminal defining an input terminal for coupling to an operator's body capacitance to ground;

27

- a charge pump circuit coupled to said oscillator for receiving said square wave output signal, and coupled to said touch terminal, said charge pump circuit having an output terminal that supplies an output signal having a voltage that varies when said touch terminal is proximal or touched by an operator's body; and
- a floating common generator coupled to said oscillator for receiving said square wave output signal, said floating common generator generating a floating common reference for said charge pump circuit that is set at a fixed voltage below and tracks said square wave output signal.

wherein said charge pump circuit includes at least one high speed diode coupled between said oscillator and said touch terminal, for enhancing a sensitivity at which said charge pump responds to sensed body capacitance to ground at said touch terminal for higher frequencies.

17. The proximity and touch controlled circuit as defined in claim 16, wherein said charge pump circuit is powered by said square wave output signal provided by said oscillator and by said floating common reference provided by said floating common generator thereby increasing the sensitivity of said charge pump circuit to proximity and touching of said touch terminal by an operator's body.

18. A capacitive responsive electronic switching circuit comprising:

- an oscillator providing a periodic output signal having a predefined frequency;
- a plurality of input touch terminals defining adjacent areas on a dielectric substrate for an operator to provide inputs by proximity and touch; and
- a detector circuit coupled to said oscillator for receiving said periodic output signal from said oscillator, and coupled to said input touch terminals, said detector circuit being responsive to signals from said oscillator and the presence of an operator's body capacitance to ground coupled said touch terminals when proximal or touched by an operator to provide a control output signal.

wherein said predefined frequency of said oscillator is selected to decrease the impedance of said dielectric substrate relative to the impedance of any contaminate that may create an electrical on said dielectric substrate path between said adjacent areas, and wherein said detector circuit compares the sensed body capacitance to ground proximate an input touch terminal to a threshold level to prevent inadvertent generation of the control output signal.

19. The switching circuit as defined in claim 18, wherein said oscillator provides a periodic output signal having a frequency of 800 kHz or greater.

20. A capacitive responsive electronic switching circuit comprising:

- an oscillator providing a periodic output signal having a predefined frequency;
- a dome-shaped touch terminal defining an area for an operator to provide an input by proximity and touch, wherein the dome shape of the touch terminal is constructed to ergonomically fit the palm of a human hand; and
- a detector circuit coupled to said oscillator for receiving said periodic output signal from said oscillator, and coupled to said touch terminal, said detector circuit being responsive to signals from said oscillator and the presence of an operator's body capacitance to ground

28

coupled to said touch terminal when proximal or touched by an operator to provide a control output signal, said detector circuit including means for discriminating between a proximity and touch of said dome-shaped touch terminal by the palm of a human hand and a proximity and touch by a human finger.

21. A capacitive responsive electronic switching circuit comprising:

- an oscillator providing a periodic output signal having a predefined frequency;
- a touch terminal defining an area for an operator to provide an input by proximity and touch; and
- a detector circuit coupled to said oscillator for receiving said periodic output signal from said oscillator, and coupled to said touch terminal, said detector circuit being responsive to signals from said oscillator and the presence of an operator's body capacitance to ground coupled to said touch terminal when proximal or touched by an operator to provide a control output signal, said detector circuit including discriminating means for discriminating between a proximity and touch of said touch terminal covering substantially all of said area of said touch terminal and a proximity and touch covering less than substantially all of said area of said touch terminal.

22. The switching circuit as defined in claim 21, wherein said touch terminal includes a dome-shaped dielectric cover.

23. The switching circuit as defined in claim 21, wherein said touch terminal includes a palm-sized dielectric cover.

24. The switching circuit as defined in claim 23, wherein said discriminating means determines that a proximity and touch of said touch terminal covers substantially all of said area of said touch terminal when said dielectric cover is proximal or touched with the palm of an operator's hand and determines that a proximity or touch covers less than substantially all of said area of said touch terminal when said dielectric cover is proximal or touched with one of an operator's fingers.

25. The switching circuit as defined in claim 21, wherein said discriminating means discriminates between a proximity and touch of said touch terminal covering substantially all of said area of said touch terminal and a proximity and touch covering less than substantially all of said area of said touch terminal based upon a sensed level of body capacitance to ground proximate said touch terminal.

26. The switching circuit as defined in claim 21, wherein said coupling of capacitance to ground occurs when an operator's body is proximate, but not touching, said touch terminal.

27. A capacitive responsive electronic switching circuit for a controlled device comprising:

- an oscillator providing a periodic output signal having a predefined frequency;
- first and second touch terminals defining areas for an operator to provide an input by proximity and touch; and
- a detector circuit coupled to said oscillator for receiving said periodic output signal from said oscillator, and coupled to said first and second touch terminals, said detector circuit being responsive to signals from said oscillator and the presence of an operator's body capacitance to ground coupled to said first and second touch terminals when proximal or touched by an operator to provide a control output signal for actuation of the controlled device, said detector circuit being con-

29

figured to generate said control output signal when said an operator is proximal or touches said second touch terminal after the operator is proximal or touches said first touch terminal.

28. The capacitive responsive electronic switching circuit as defined in claim 27, wherein said detector circuit generates said control signal only when an operator is proximal or touches said second touch terminal within a predetermined time period after the operator is proximal or touches said first touch terminal.

29. The capacitive responsive electronic switching circuit as defined in claim 27, wherein said first and second touch terminals are adapted to be mounted on different surfaces of the controlled device.

30

30. The capacitive responsive electronic switching circuit as defined in claim 27, wherein said first and second touch terminals are adapted to be mounted on non-parallel planar surfaces of the controlled device.

31. The capacitive responsive electronic switching circuit as defined in claim 27, wherein said first and second touch terminals are adapted to be mounted on perpendicular planar surfaces of the controlled device.

32. The capacitive responsive electronic switching circuit as defined in claim 27 and further including an indicator for indicating when said detector circuit determines that an operator is proximal or touches said first touch terminal.

* * * * *

UNITED STATES PATENT AND TRADEMARK OFFICE
CERTIFICATE OF CORRECTION

PATENT NO. : 5,796,183
DATED : August 18, 1998
INVENTOR(S) : Byron Hourmand

Page 1 of 3

It is certified that error appears in the above-identified patent and that said Letters Patent is hereby corrected as shown below:

Column 5, line 52, "such a" should be --such as--.

Column 9, line 31, before "water" insert --condensed--.

Column 14, line 35, "is" should be --as--.

Column 13, line 65, "it's" should be --its--.

Column 18, line 38, "references" should be --reference--.

Column 20, line 7, "it's" should be --its-- (both occurrences).

Column 20, line 9, "it's" should be --its--.

Column 20, line 10, "it's" should be --its-- (both occurrences).

Column 20, line 13, "it's" should be --its--.

Column 20, line 20, "it's" should be --its--.

Column 20, line 39, "it's" should be --its--.

Column 20, line 40, "it's" should be --its--.

Column 20, line 46, "it's" should be --its--.

Column 20, line 47, "it's" should be --its--.

UNITED STATES PATENT AND TRADEMARK OFFICE
CERTIFICATE OF CORRECTION

PATENT NO. : 5,796,183
DATED : August 18, 1998
INVENTOR(S) : Byron Hourmand

Page 2 of 3

It is certified that error appears in the above-identified patent and that said Letters Patent is hereby corrected as shown below:

Column 21, line 8, "it's" should be --its--.

Column 21, line 9, "it's" should be --its--.

Column 21, line 15, "it's" should be --its--.

Column 21, line 42, "it's" should be --its--.

Column 21, line 46, "it's" should be --its--.

Column 21, line 47, "it's" should be --its--.

Column 21, line 56, "it's" should be --its--.

Column 22, line 8, "it's" should be --its--.

Column 22, line 13, "schmitt" should be --Schmitt--.

Column 26, lines 22-27, after "microcontroller." delete "by an operator's body . . . higher frequencies."

UNITED STATES PATENT AND TRADEMARK OFFICE
CERTIFICATE OF CORRECTION

PATENT NO. : 5,796,183
DATED : August 18, 1998
INVENTOR(S) : Byron Hourmand

Page 3 of 3

It is certified that error appears in the above-identified patent and that said Letters Patent is hereby corrected as shown below:

Column 27, line 44, after "electrical" insert --path--.

Column 27, line 45, delete "path".

Column 29, line 1, after "when" delete "said".

Signed and Sealed this
Eleventh Day of May, 1999

Attest:



Q. TODD DICKINSON

Attesting Officer

Acting Commissioner of Patents and Trademarks

UNITED STATES PATENT AND TRADEMARK OFFICE
CERTIFICATE OF CORRECTION

PATENT NO. : 5,796,183
APPLICATION NO. : 08/601268
DATED : August 18, 1998
INVENTOR(S) : Byron Hourmand et al.

Page 1 of 1

It is certified that error appears in the above-identified patent and that said Letters Patent is hereby corrected as shown below:

Title Page, Item (75) Inventor, should read --(75) Inventors: Byron Hourmand,
Hersey, MI (US); John M. Washeleski, Cadillac, MI (US); Stephen R. W. Cooper,
Fowlerville, MI (US)--.

Signed and Sealed this
Eleventh Day of October, 2011

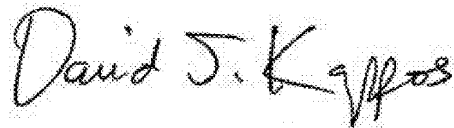
A handwritten signature in black ink that reads "David J. Kappos". The signature is written in a cursive style with a large, stylized "D" and "K".

David J. Kappos
Director of the United States Patent and Trademark Office

Under the Paperwork Reduction Act of 1995, no persons are required to respond to a collection of information unless it displays a valid OMB control number.

STATEMENT UNDER 37 CFR 3.73(b)Applicant/Patent Owner: HourmandApplication No./Patent No.: 5,796,183 Filed/Issue Date: August 18, 1998Titled: **Capacitive Responsive Electronic Switching Circuit**UUSI, LLC, a Corporation
(Name of Assignee) (Type of Assignee, e.g., corporation, partnership, university, government agency, etc.)

states that it is:

1. the assignee of the entire right, title, and interest in;
2. an assignee of less than the entire right, title and interest in
(The extent (by percentage) of its ownership interest is _____ %); or
3. the assignee of an undivided interest in the entirety of (a complete assignment from one of the joint inventors was made)

the patent application/patent identified above, by virtue of either:

- A. An assignment from the inventor(s) of the patent application/patent identified above. The assignment was recorded in the United States Patent and Trademark Office at Reel _____, Frame _____, **or for which a copy thereof is attached.**

OR

- B. A chain of title from the inventor(s), of the patent application/patent identified above, to the current assignee as follows:

1. From: Byron Hourmand To: Nartron Corporation

The document was recorded in the United States Patent and Trademark Office at
Reel 008254, Frame 0496, or for which a copy thereof is attached.

2. From: Byron Hourmand To: Nartron Corporation

The document was recorded in the United States Patent and Trademark Office at
Reel 008443, Frame 0749, or for which a copy thereof is attached.

3. From: John M. Washeleski To: Nartron Corporation

The document was recorded in the United States Patent and Trademark Office at
Reel _____, Frame _____, **or for which a copy thereof is attached.**

Additional documents in the chain of title are listed on a supplemental sheet(s).

- As required by 37 CFR 3.73(b)(1)(i), the documentary evidence of the chain of title from the original owner to the assignee was, or concurrently is being, submitted for recordation pursuant to 37 CFR 3.11.

[NOTE: A separate copy (*i.e.*, a true copy of the original assignment document(s)) must be submitted to Assignment Division in accordance with 37 CFR Part 3, to record the assignment in the records of the USPTO. See MPEP 302.08]

The undersigned (whose title is supplied below) is authorized to act on behalf of the assignee.

/Brian A. Carlson/
Signature

August 17, 2012
Date

Brian A. Carlson, Reg. No. 37,793
Printed or Typed Name

Attorney for Assignee
Title

This collection of information is required by 37 CFR 3.73(b). The information is required to obtain or retain a benefit by the public which is to file (and by the USPTO to process) an application. Confidentiality is governed by 35 U.S.C. 122 and 37 CFR 1.11 and 1.14. This collection is estimated to take 12 minutes to complete, including gathering, preparing, and submitting the completed application form to the USPTO. Time will vary depending upon the individual case. Any comments on the amount of time you require to complete this form and/or suggestions for reducing this burden, should be sent to the Chief Information Officer, U.S. Patent and Trademark Office, U.S. Department of Commerce, P.O. Box 1450, Alexandria, VA 22313-1450. DO NOT SEND FEES OR COMPLETED FORMS TO THIS ADDRESS. **SEND TO: Commissioner for Patents, P.O. Box 1450, Alexandria, VA 22313-1450.**

If you need assistance in completing the form, call 1-800-PTO-9199 and select option 2.



UNITED STATES PATENT AND TRADEMARK OFFICE

UNITED STATES DEPARTMENT OF COMMERCE
 United States Patent and Trademark Office
 Address: COMMISSIONER FOR PATENTS
 P.O. Box 1450
 Alexandria, Virginia 22313-1450
 www.uspto.gov



Bib Data Sheet

CONFIRMATION NO. 4155

SERIAL NUMBER 90/012,439	FILING OR 371(c) DATE 08/17/2012 RULE	CLASS 307	GROUP ART UNIT 3992	ATTORNEY DOCKET NO. 5796183RX	
APPLICANTS 5796183, Residence Not Provided; OWNER, REED CITY, MI; PATENT OWNER, REED CITY, MI;					
** CONTINUING DATA ***** This application is a REX of 08/601,268 01/31/1996 PAT 5796183					
** FOREIGN APPLICATIONS *****					
Foreign Priority claimed <input type="checkbox"/> yes <input type="checkbox"/> no		STATE OR COUNTRY	SHEETS DRAWING	TOTAL CLAIMS 32	INDEPENDENT CLAIMS 8
35 USC 119 (a-d) conditions met <input type="checkbox"/> yes <input type="checkbox"/> no <input type="checkbox"/> Met after Allowance					
Verified and Acknowledged		Examiner's Signature _____ Initials _____			
ADDRESS 22045					
TITLE Capacitive Responsive Electronic Switching Circuit					
FILING FEE RECEIVED 2520	FEES: Authority has been given in Paper No. _____ to charge/credit DEPOSIT ACCOUNT No. _____ for following:		<input type="checkbox"/> All Fees <input type="checkbox"/> 1.16 Fees (Filing) <input type="checkbox"/> 1.17 Fees (Processing Ext. of time) <input type="checkbox"/> 1.18 Fees (Issue) <input type="checkbox"/> Other _____ <input type="checkbox"/> Credit		