

UNITED STATES PATENT AND TRADEMARK OFFICE

BEFORE THE PATENT TRIAL AND APPEAL BOARD

APPLE, INC.
Petitioner,

v.

UUSI, LLC d/b/a NARTRON
Patent Owner.

Case IPR2019-00356
Patent 5,796,183

Before BRYAN F. MOORE, MINN CHUNG, and
NORMAN H. BEAMER, *Administrative Patent Judges*.

BEAMER, *Administrative Patent Judge*.

DECISION
Denying Institution of *Inter Partes* Review
35 U.S.C. § 314(a)

I. INTRODUCTION

On November 29, 2018, Apple, Inc. (“Petitioner”) filed a Petition (Paper 2, “Pet.”) pursuant to 35 U.S.C. §§ 311–319 to institute an *inter partes* review of claims 28, 32, 36, 83–88, and 90–93 of U.S. Patent No. 5,796,183 (“the ’183 patent”). On April 23, 2019, UUSI, LLC d/b/a Nartron (“Patent Owner”) filed a Preliminary Response (Paper 10, “Prelim. Resp.”). Pursuant to a May 22, 2019 Order (Paper 11), the parties exchanged briefs further addressing the issue of discretionary denial of institution under 35 U.S.C. § 314(a) (Papers 12, 13).

Applying the standard set forth in 35 U.S.C. § 314(a), which requires demonstration of a reasonable likelihood that Petitioner would prevail with respect to at least one challenged claim, we deny the Petition and do not institute an *inter partes* review.

II. BACKGROUND

A. The ’183 Patent

The ’183 patent, titled “Capacitive Responsive Electronic Switching Circuit,” was filed January 31, 1996, and issued August 18, 1998. Ex. 1001, [22], [45], [54]. The ’183 patent has expired. Prelim. Resp. 17.

The ’183 patent relates to a “capacitive responsive electronic switching circuit used to make possible a ‘zero force’ manual electronic switch.” Ex. 1001, 1:6–9. According to the ’183 patent, zero force touch switches have no moving parts and no contact surfaces that directly switch loads. *Id.* at 2:40–41. Instead, such switches detect an operator’s touch and use solid state electronics to switch loads or activate mechanical relays. *Id.* at 2:42–44. “A common solution used to achieve a zero force touch switch has been to make use of the capacitance of the human operator.” *Id.* at 3:12–

14. The '183 patent recites three methods used by capacitive touch switches to detect an operator's touch, one of which relies on the change in capacitive coupling between a touch terminal and ground. *Id.* at 3:13–15, 3:44–46. In this method, “[t]he touch of an operator then provides a capacitive short to ground via the operator's own body capacitance.” *Id.* at 3:52–55. Figure 8, reproduced below, is an example that makes use of this method.

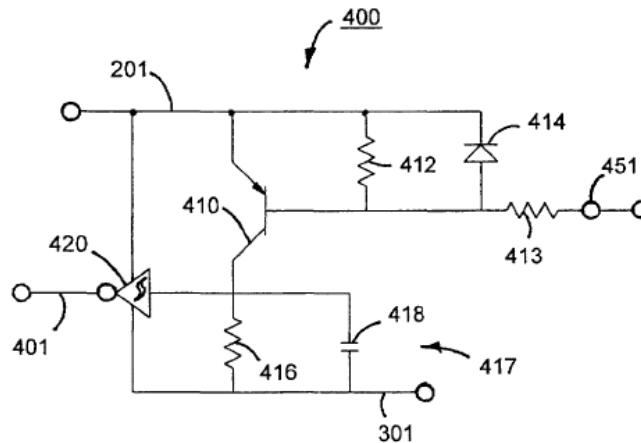

Fig. 8

Figure 8 depicts a “touch circuit” in which, when a pad (not shown) is touched to create a short to ground via terminal 451, transistor 410 turns on and connects a high frequency input at 201 to resistor/capacitor circuit 416/418, thus triggering Schmitt Trigger 420 to provide control output 401. *Id.* at 14:47–52, 15:17–47. Significantly, the operator of a capacitive touch switch using this method need not come in conductive contact with the touch terminal. *Id.* at 3:57–59. Rather, the operator needs only to come into close proximity of the switch. *Id.*

Figure 11 of the '183 patent is reproduced below.

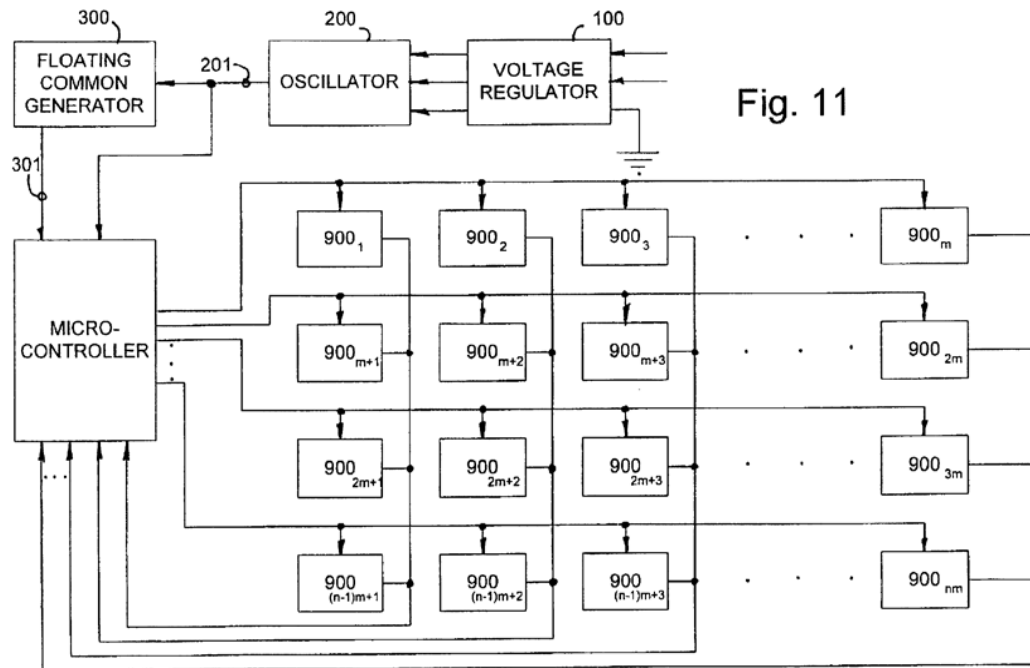

Fig. 11

Figure 11 depicts a “multiple touch pad circuit” including “an array of touch circuits” 900₁ through 900_{nm}. *Id.* at 18:34–43. The microcontroller selects successive rows of the touch circuit array by providing the signal from oscillator 200 sequentially to each row. *Id.* at 18:43–46. A particular activated touch circuit is detected by the microcontroller via association of an activated row with received input from a column line of the array. *Id.* at 18:46–49.

The '183 patent recognizes that placing capacitive touch switches in dense arrays, as in Figure 11, can result in unintended actuations. *Id.* at 3:65–4:3. One method of addressing this problem known in the art involves placing guard rings around each touch pad. *Id.* at 4:4–7. Another known method of addressing this problem is to adjust the sensitivity of the touch pad such that the operator's finger must entirely overlap a touch terminal.

Id. at 4:8–14. “Although these methods (guard rings and sensitivity adjustment) have gone a considerable way in allowing touch switches to be spaced in comparatively close proximity, a susceptibility to surface contamination remains as a problem.” *Id.* at 4:14–18.

The ’183 patent uses the technique of Figure 11 to overcome the problem of unintended actuation of small capacitive touch switches “by using the method of sensing body capacitance to ground in conjunction with redundant detection circuits.” *Id.* at 5:33–35. Specifically, the ’183 patent’s touch detection circuit operates at frequencies at or above 50 kHz, and preferably at or above 800 kHz, in order to minimize the effects of surface contamination on the touch pads. *Id.* at 11:19–29. Operating at these frequencies also improves sensitivity, allowing close control of the proximity required for actuation of small-sized touch terminals in a close array, such as a keyboard. *Id.* at 5:48–57.

B. The Claims

Independent claim 27, reproduced below, was cancelled in *ex parte* reexamination. Ex. 1007, 51.¹ Nonetheless, because claims 28, 32, and 36, which depend from claim 27, are challenged, we consider claim 27 as part of those claims.

27. A capacitive responsive electronic switching circuit for a controlled keypad device comprising:
an oscillator providing a periodic output signal having a predefined frequency;

¹ Citations to Exhibits 1006 and 1007, which are the file histories for reexamination requests 90/012,439 and 90/013,106, refer to consecutive page numbers applied to the exhibits.

Explore Litigation Insights

Docket Alarm provides insights to develop a more informed litigation strategy and the peace of mind of knowing you're on top of things.

Real-Time Litigation Alerts



Keep your litigation team up-to-date with **real-time alerts** and advanced team management tools built for the enterprise, all while greatly reducing PACER spend.

Our comprehensive service means we can handle Federal, State, and Administrative courts across the country.

Advanced Docket Research



With over 230 million records, Docket Alarm's cloud-native docket research platform finds what other services can't. Coverage includes Federal, State, plus PTAB, TTAB, ITC and NLRB decisions, all in one place.

Identify arguments that have been successful in the past with full text, pinpoint searching. Link to case law cited within any court document via Fastcase.

Analytics At Your Fingertips



Learn what happened the last time a particular judge, opposing counsel or company faced cases similar to yours.

Advanced out-of-the-box PTAB and TTAB analytics are always at your fingertips.

API

Docket Alarm offers a powerful API (application programming interface) to developers that want to integrate case filings into their apps.

LAW FIRMS

Build custom dashboards for your attorneys and clients with live data direct from the court.

Automate many repetitive legal tasks like conflict checks, document management, and marketing.

FINANCIAL INSTITUTIONS

Litigation and bankruptcy checks for companies and debtors.

E-DISCOVERY AND LEGAL VENDORS

Sync your system to PACER to automate legal marketing.