

[54] **INDUCTION COOK-TOP WITH IMPROVED TOUCH CONTROL**

[75] Inventors: **Raymond M. Tucker; Clarence L. Dyer; Gregory P. Maman**, all of Cleburne, Tex.

[73] Assignee: **Rangaire Corporation**, Cleburne, Tex.

[21] Appl. No.: **35,083**

[22] Filed: **May 1, 1979**

[51] Int. Cl.<sup>3</sup> ..... **H05B 6/06; H05B 6/12; G08C 9/02**

[52] U.S. Cl. .... **219/10.49 R; 219/10.77; 219/506; 307/116; 340/365 C; 340/365 E; 328/5; 200/DIG. 1**

[58] **Field of Search** ..... **219/10.77, 10.49 R, 219/10.55 B, 445, 453, 459, 492-494, 490, 497, 499, 501, 506; 200/DIG. 1; 307/116, 126, 96, 97, 308, 252 K, 252 M, 238, 239, 296; 363/57, 135, 95, 96; 361/94, 97; 328/48, 71, 5; 340/365 S, 365 C, 365 E, 366 R, 382, 716; 235/92 CT, 92 EV, 92 PE; 323/101**

[56] **References Cited**

**U.S. PATENT DOCUMENTS**

3,530,310 9/1970 Adelson et al. .... 340/365 C

3,530,499 9/1970 Schroeder ..... 219/10.49 R

3,637,970 1/1972 Cunningham ..... 219/10.75

3,697,716 10/1972 Kornrumpf ..... 219/10.49 R

3,697,717 10/1972 Kornrumpf ..... 219/10.49 R

3,701,869 10/1972 Jacob et al. .... 200/167 R

3,710,062 1/1973 Peters, Jr. .... 219/10.49 R

3,711,672 1/1973 Moreland ..... 219/10.49 R

3,715,550 2/1973 Harnden, Jr. .... 219/10.49 R

3,719,789 3/1973 Harnden, Jr. .... 219/10.49 R

3,742,173 6/1973 Kornrumpf et al. .... 219/10.41

3,742,174 6/1973 Harnden, Jr. .... 219/10.49 R

3,742,175 6/1973 Harnden, Jr. .... 219/10.49 R

3,742,178 6/1973 Harnden, Jr. .... 219/10.49 R

3,742,179 6/1973 Harnden, Jr. .... 219/10.49 R

3,742,337 6/1973 Digneffe ..... 307/252 B

3,745,290 7/1973 Harnden, Jr. et al. .... 219/10.49 R

3,745,450 7/1973 Wilt ..... 340/382

3,761,667 9/1973 Walden ..... 219/10.49 R

3,761,668 9/1973 Harnden, Jr. et al. .... 219/10.49 R

3,770,928 11/1973 Kornrumpf et al. .... 219/10.49 R

3,775,577 11/1973 Peters, Jr. .... 219/10.49 R

3,777,094 12/1973 Peters, Jr. .... 219/10.49 R

3,781,503 12/1973 Harnden, Jr. et al. .... 219/10.49 R

3,781,504 12/1973 Harnden, Jr. .... 219/10.49 R

3,781,506 12/1973 Ketchum ..... 219/10.49 R

3,781,508 12/1973 Steigerwald ..... 219/10.49 R

3,786,219 1/1974 Kornrumpf et al. .... 219/10.49 R

3,786,220 1/1974 Harnden, Jr. .... 219/10.49 R

3,786,222 1/1974 Harnden, Jr. et al. .... 219/10.49 R

3,796,850 3/1974 Moreland et al. .... 219/10.49 R

3,806,688 4/1974 Mackenzie et al. .... 219/10.49 R

3,814,888 6/1974 Bowers et al. .... 219/10.49 R

3,820,005 6/1974 Steigerwald ..... 219/10.77 X

3,823,297 7/1974 Cunningham ..... 219/10.77

3,843,857 10/1974 Cunningham ..... 219/10.49 R

3,852,558 12/1974 McCleerey et al. .... 219/10.49 R

3,886,342 5/1975 Peters, Jr. .... 219/10.49 R

3,887,781 6/1975 Peters, Jr. .... 219/10.49 R

3,887,848 6/1975 Larson et al. .... 200/DIG. 1

3,889,090 6/1975 Makenzie ..... 219/10.49 R

3,898,410 8/1975 Peters, Jr. .... 219/10.49 R

3,906,181 9/1975 Hibino et al. .... 219/10.49 R

3,925,633 12/1975 Partridge ..... 219/10.49 R

3,927,336 12/1975 Carlson et al. .... 307/116 X

3,928,744 12/1975 Hibino et al. .... 219/10.49 R

3,932,801 1/1976 Peters, Jr. .... 219/10.49 R X

3,947,652 3/1976 Cobb ..... 219/10.79

3,949,183 4/1976 Usami et al. .... 219/10.49

3,953,783 4/1976 Peters, Jr. .... 219/10.49 R X

3,966,426 6/1976 McCoy et al. .... 219/10.49 R X

3,974,472 8/1976 Gould, Jr. .... 219/506 X

4,010,342 3/1977 Austin ..... 219/10.49 R

4,011,428 3/1977 Fosnough et al. .... 219/10.55 B

4,046,991 9/1977 Sefton et al. .... 219/497

4,074,101 2/1978 Kiuchi et al. .... 219/10.49 R

4,081,700 3/1978 Hamilton ..... 328/5 X

4,105,902 8/1978 Iwai et al. .... 340/365 E X

4,149,217 4/1979 Tucker ..... 219/10.77

4,158,759 6/1979 Mason ..... 219/506 X

**OTHER PUBLICATIONS**

"Power on Reset For Machine Circuits", IBM Technical Disclosure Bulletin, vol. 9, No. 6, Nov. 1966.

G.E. Semiconductor Products Department, "A Low Cost, Ultrasonic Frequency Inverter using a Single SCR," Note 200.49, Neville Mapham, Feb., 1967.

Environmental/one, "Annual Report, Licensing Business".

IEEE Transactions on Industry Applications, "The

Induction Range: Its Performance and Its Development Problems", W. C. Moreland II, Jan./Feb., 1973, vol. 1A-9, No. 1.

IEEE Transactions on Industry Applications, "A Portable Cool-Surface Induction Cooking Appliances", Philip, Peters, Nov./Dec. 1974, vol. 1A-10, No. 6.

"Induction Range Circuits—Past, Present, Future", Jul. 30, 1973.

"Non-Heating Range Using Induction Method", Mitsubishi Electric Corp.

RCA, Solid State Division, Thyristors and Rectifiers "Characteristics and Applications of RCA Fast-Switching ASCR's", Application note AN6456, Henri Digneffe, Jan. 1976.

"Solid State Power Control Program", Dr. Richard G. Hoft, Aug. 21, 1973.

*Primary Examiner*—Gene Z. Rubinson

*Assistant Examiner*—Philip H. Leung

*Attorney, Agent, or Firm*—Richards, Harris & Medlock

[57]

#### ABSTRACT

An induction heating system (40) is provided and includes a plurality of induction heating coils (118). Touch control pads (50, 52, 70, and 72) are provided together with circuitry (80) for generating energization control signals. Circuitry (112 and 116) is provided for electrically energizing the induction heating coils (118). An electronic digital processor (82) is responsive to the energization control signals for generating energization signals for actuating and controlling the energization circuitry (112 and 116) to thereby vary the energization of the plurality of induction heating coils (118). Circuitry (150 and 152) is provided for maintaining touch control pads (50, 52, 70 and 72) operable when an operator is in contact with a pan disposed adjacent the plurality of induction heating coils (118).

**13 Claims, 24 Drawing Figures**

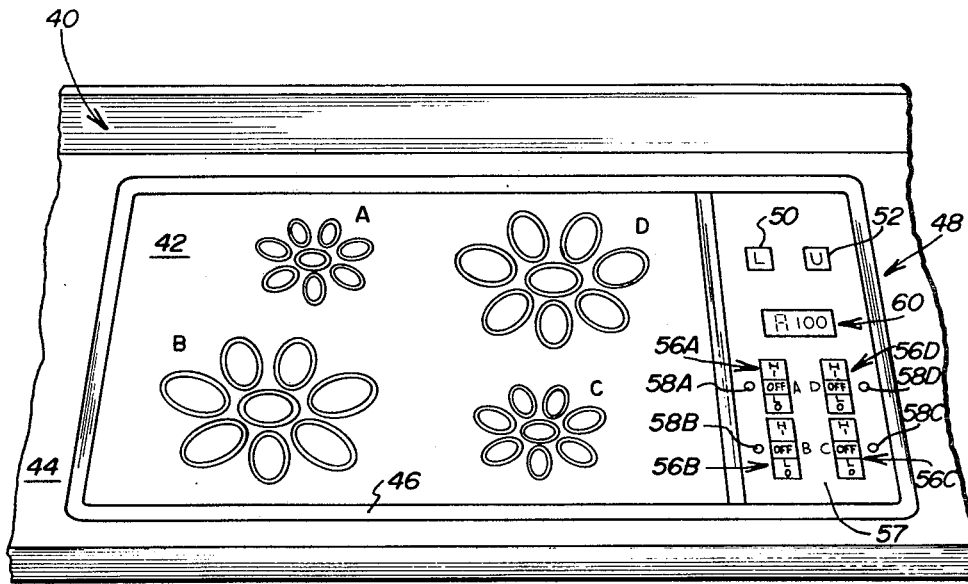

FIG. 1

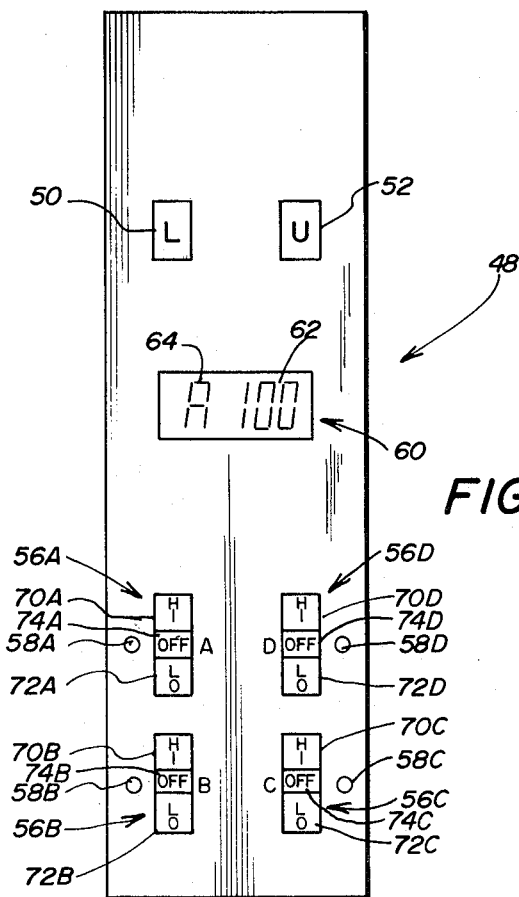

FIG. 2

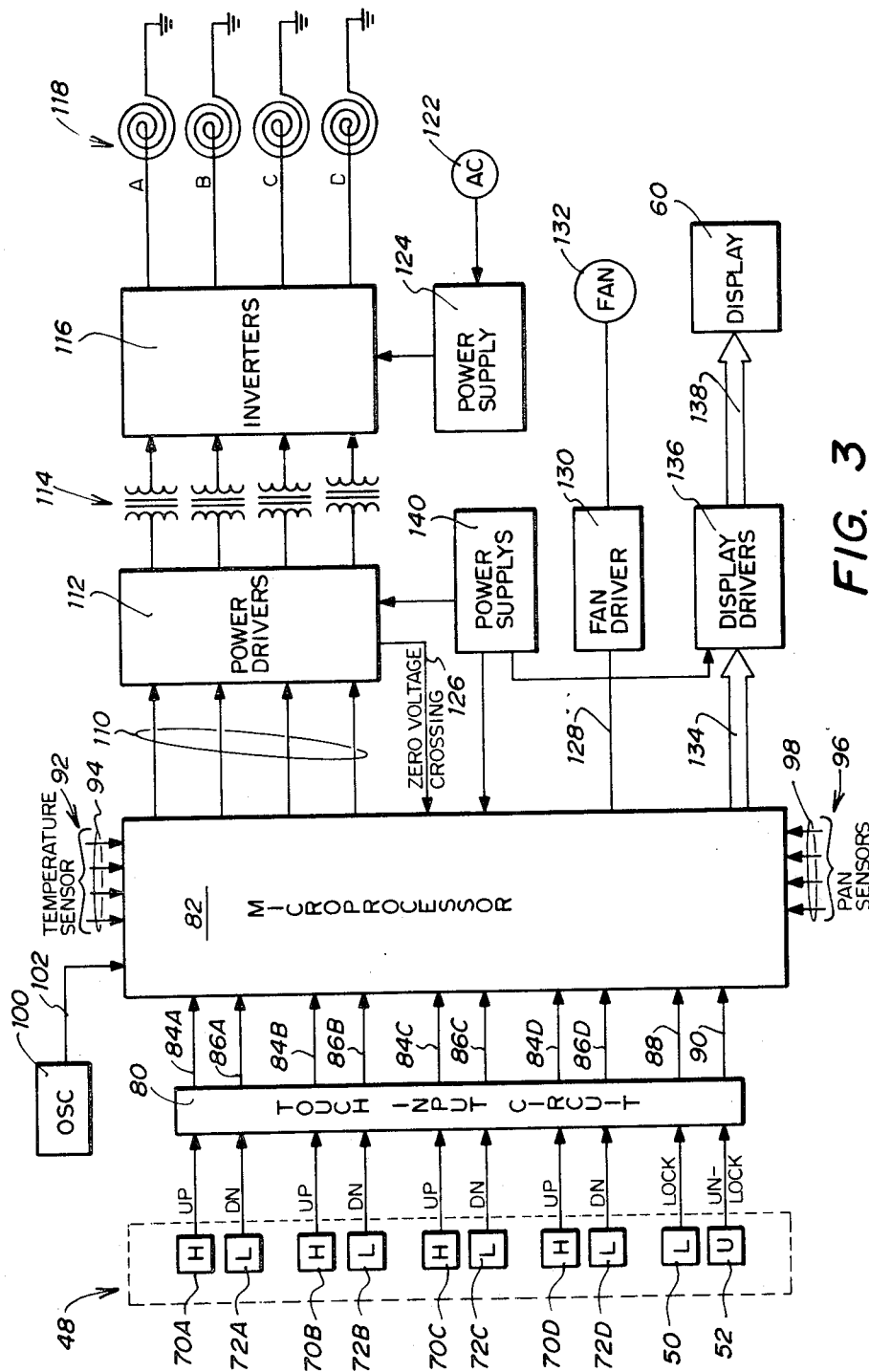

FIG. 3

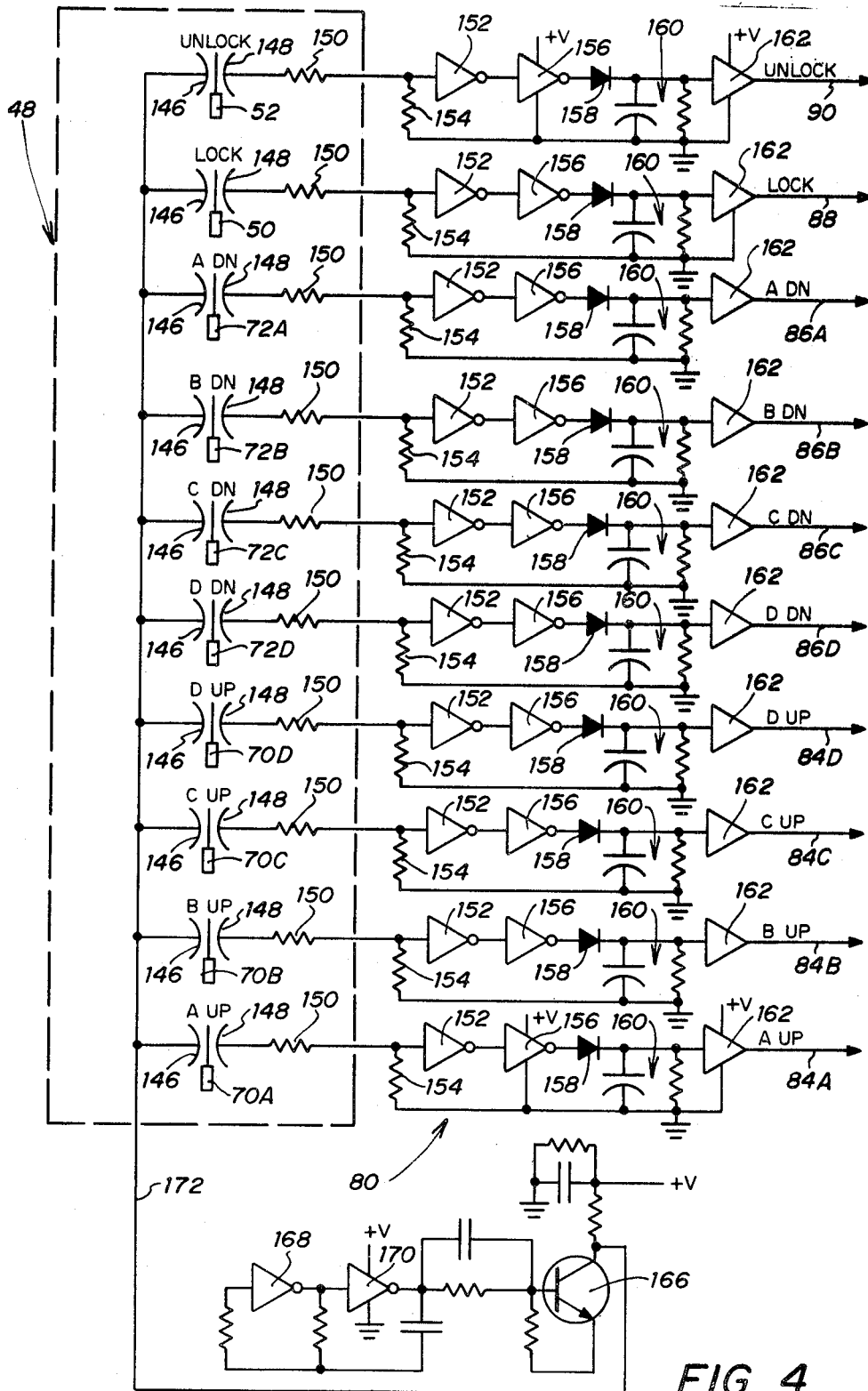

FIG. 4

# Explore Litigation Insights

Docket Alarm provides insights to develop a more informed litigation strategy and the peace of mind of knowing you're on top of things.

## Real-Time Litigation Alerts



Keep your litigation team up-to-date with **real-time alerts** and advanced team management tools built for the enterprise, all while greatly reducing PACER spend.

Our comprehensive service means we can handle Federal, State, and Administrative courts across the country.

## Advanced Docket Research



With over 230 million records, Docket Alarm's cloud-native docket research platform finds what other services can't. Coverage includes Federal, State, plus PTAB, TTAB, ITC and NLRB decisions, all in one place.

Identify arguments that have been successful in the past with full text, pinpoint searching. Link to case law cited within any court document via Fastcase.

## Analytics At Your Fingertips



Learn what happened the last time a particular judge, opposing counsel or company faced cases similar to yours.

Advanced out-of-the-box PTAB and TTAB analytics are always at your fingertips.

## API

Docket Alarm offers a powerful API (application programming interface) to developers that want to integrate case filings into their apps.

## LAW FIRMS

Build custom dashboards for your attorneys and clients with live data direct from the court.

Automate many repetitive legal tasks like conflict checks, document management, and marketing.

## FINANCIAL INSTITUTIONS

Litigation and bankruptcy checks for companies and debtors.

## E-DISCOVERY AND LEGAL VENDORS

Sync your system to PACER to automate legal marketing.