

Notice of Intent to Issue Ex Parte Reexamination Certificate	Control No. 90/013,106	Patent Under Reexamination 5796183	
	Examiner HENRY N. TRAN	Art Unit 3992	AIA (First Inventor to File) Status No

-- The MAILING DATE of this communication appears on the cover sheet with the correspondence address --

1. Prosecution on the merits is (or remains) closed in this *ex parte* reexamination proceeding. This proceeding is subject to reopening at the initiative of the Office or upon petition. Cf. 37 CFR 1.313(a). A Certificate will be issued in view of
 - (a) Patent owner's communication(s) filed: 07 May 2014.
 - (b) Patent owner's failure to file an appropriate timely response to the Office action mailed: _____.
 - (c) Patent owner's failure to timely file an Appeal Brief (37 CFR 41.31).
 - (d) The decision on appeal by the Board of Patent Appeals and Interferences Court dated _____
 - (e) Other: _____.
2. The Reexamination Certificate will indicate the following:
 - (a) Change in the Specification: Yes No
 - (b) Change in the Drawing(s): Yes No
 - (c) Status of the Claim(s):
 - (1) Patent claim(s) confirmed: _____.
 - (2) Patent claim(s) amended (including dependent on amended claim(s)): _____
 - (3) Patent claim(s) canceled: 18,27 and 35.
 - (4) Newly presented claim(s) patentable: 40-117.
 - (5) Newly presented canceled claims: _____.
 - (6) Patent claim(s) previously currently disclaimed: _____
 - (7) Patent claim(s) not subject to reexamination: 1-17,19-26,28-34 and 36-39.
3. A declaration(s)/affidavit(s) under **37 CFR 1.130(b)** was/were filed on _____.
4. Note the attached statement of reasons for patentability and/or confirmation. Any comments considered necessary by patent owner regarding reasons for patentability and/or confirmation must be submitted promptly to avoid processing delays. Such submission(s) should be labeled: "Comments On Statement of Reasons for Patentability and/or Confirmation."
5. Note attached NOTICE OF REFERENCES CITED (PTO-892).
6. Note attached LIST OF REFERENCES CITED (PTO/SB/08 or PTO/SB/08 substitute).
7. The drawing correction request filed on _____ is: approved disapproved.
8. Acknowledgment is made of the priority claim under 35 U.S.C. § 119(a)-(d) or (f).
 - a) All b) Some* c) None of the certified copies have
 - been received.
 - not been received.
 - been filed in Application No. _____.
 - been filed in reexamination Control No. _____.
 - been received by the International Bureau in PCT Application No. _____.

* Certified copies not received: _____.
9. Note attached Examiner's Amendment.
10. Note attached Interview Summary (PTO-474).
11. Other: _____.

All correspondence relating to this reexamination proceeding should be directed to the **Central Reexamination Unit** at the mail, FAX, or hand-carry addresses given at the end of this Office action.

/HENRY N TRAN/
Primary Examiner
Art Unit: 3992

cc: Requester (if third party requester)

The present application is being examined under the pre-AIA first to invent provisions.

NOTICE OF INTENT TO ISSUE *EX PARTE* REEXAMINATION CERTIFICATE

INTRODUCTION

1. This Notice of Intent to Issue *Ex Parte* Reexamination Certificate (NIRC) action concerns the *Ex Parte* Reexamination Request (hereinafter “the Request”) filed by patent owner on December 24, 2013 for the *Ex Parte* Reexamination Certificate, the U.S. Patent No. 5,786,183 C1, issued on April 29, 2013 to Hourmand et al. (hereinafter “the ‘183 patent”); and it is responsive to the patent owner’s response filed on May 7, 2014 (hereinafter “the response”). The response has been entered. Claims 40-117 are subject to this reexamination; and they are found patentable and/or confirmed.

RESPONSE TO THE RESPONSE

2. Patent owner’s proposed amendment to the claims, see pages 2-14, filed with the response is in compliance with 37 CFR 1.530(d)-(j), and it has been entered. See M.P.E.P. § 2250. Claims 18, 27, and 35 are canceled; claims 1-17, 19-26, 28-34, and 36-39 are unamended and they are not subject to reexamination; claims 40-105 were previously added, and of which, claims 40, 41, 56, 66, 67, 71, and 95 are amended; and claims 106-117 are newly added. Thus, claims 40-117 are subject to this reexamination.

3. Patent owner’s arguments, see pages 15-141, filed with the response, with respect to the claim rejections under 35 U.S.C. § 305, the prior art references of Boie, Gerpheide, Lee, and Casio, and

the supports for new claims 40-117, have been fully considered and are persuasive. The rejection of claims 18, 27, 40-44, 56-71, and 95-105 under 35 U.S.C. § 305 as recited in the prior Office action mailed on March 27, 2014 has been overcome, and it has been withdrawn.

REFERENCES CITED IN THIS OFFICE ACTION

3. The prior art patents and printed publications (the prior art references) cited in the Request pursuant to C.F.R. § 1.510(b) (3), see the Request page 10, and relied upon are relisted below:

- U.S. Patent No. 5,463,388 issued to Boie et al. on October 31, 1995 ("Boie" or the '388 patent), which was submitted with the request as Exhibit C.
- U.S. Patent No. 5,565,658 issued to Gerpheide et al. on October 15, 1996 ("Gerpheide" or the '658 patent), which was submitted with the request as Exhibit D.
- Casio advertisement entitled "Now... The Invisible Casio Calculator Watch," published in Popular Science by On the Run in 1984 ("Casio"), which was submitted with the request as Exhibit E.
- Lee, thesis entitled "A Fast Multiple-Touch-Sensitive Input Device," and published October 1984 ("Lee"), which was submitted with the IDS filed with the request.

ALLOWABLE SUBJECT MATTER

4. New claims 40-117 are patentable.

STATEMENT OF REASONS FOR PATENTABILITY AND/OR CONFIRMATION

5. The following is an examiner's statement of reasons for patentability and/or confirmation of the claims found patentable in this reexamination proceeding:

The '183 patent generally relates to a capacitive responsive electronic switching circuit including an oscillator **200** providing a periodic output signal, a keypad having a plurality of input touch terminals **450** defining areas for an operator to provide inputs by proximity and touch, a microcontroller **500** using the periodic output signal from the oscillator for selectively providing signal output frequencies to the input touch terminals(e.g., touch terminals 57 and 59), and a detector circuit **400** coupled to the oscillator, the input touch terminals, and the microcontroller for providing a control output signal based on the presence of operator's body capacitance to ground coupled to the input touch terminal when in proximity or touched by an operator. An array of touch terminals may be provided in close proximity due to the reduction in crosstalk that may result from contaminants by utilizing an oscillator outputting signal having a frequency of 50 KHz or greater. See, the '183 patent Abstract, and Figures 3, 4 and 11. Each of the new independent claims 45, 56, 72, 84, 95, 106, and 111 identifies the uniquely distinct features that are not taught or suggested by the cited prior art references, either alone or in any reasonable combinations. Specifically,

(i) Independent claim 45 includes the new limitation of “*a microcontroller using the periodic output signal from the oscillator, the microcontroller selectively providing signal output frequencies **directly** to a plurality of small sized input touch terminals of a keypad*”

(ii) Independent claim 56 requires, *inter alia*, the features: “*a microcontroller using the periodic output signal from the oscillator, the microcontroller selectively providing signal output frequencies to a plurality of small sized input touch terminals of a keypad, and **wherein a peak voltage of the signal output frequencies is greater than a supply voltage***”;

(iii) Independent claim 72 requires, *inter alia*, the features: “a microcontroller using the periodic output signal from the oscillator, the microcontroller selectively providing signal output frequencies directly to a closely spaced array of input touch terminals of a keypad”, and “a detector circuit coupled to said oscillator for receiving said periodic output signal from said oscillator, and coupled to said input touch terminals, said detector circuit being responsive to signals from said oscillator via said microcontroller and a presence of an operator's body capacitance to ground coupled to said touch terminals when proximal or touched by the operator to provide a control output signal for actuation of the controlled keypad device, said detector circuit being configured to generate said control output signal when the operator is proximal or touch said second touch terminal after the operator is proximal or touches said first touch terminal”

(iv) independent claims 84 and 95, each requires, *inter alia*, the features: “a microcontroller using the periodic output signal from the oscillator, the microcontroller selectively providing signal output frequencies to a closely spaced array of input touch terminals of a keypad, the input touch terminals comprising first and second input touch terminals, and wherein a peak voltage of the signal output frequencies is greater than a supply voltage”;

(v) Independent claim 106 requires, *inter alia*, the features: “a microcontroller using the periodic output signal from the oscillator, the microcontroller selectively providing signal output frequencies to a plurality of small sized input touch terminals of a keypad, wherein the selectively providing comprises the microcontroller selectively providing a signal output frequency to each row of the plurality of small sized input touch terminals of a keypad”; and

(vi) Independent claim 111 requires, *inter alia*, the features: “*a microcontroller using the periodic output signal from the oscillator, the microcontroller selectively providing signal output frequencies to a closely spaced array of input touch terminals of a keypad, the input touch terminals comprising first and second input touch terminal, wherein the selectively providing comprises the microcontroller selectively providing a signal output frequency to each row of the plurality of closely spaced array of input touch terminals of a keypad.*”.

Whereas, the cited prior art references:

Boie

Boie discloses a computer input device for use as a computer mouse or keyboard comprises a thin, insulating surface covering an array **100** of electrodes arranged in a grid pattern and connected in columns and rows, each column and row is connected to circuitry **401**, which can be selected by multiplexer **402** under control of microcontroller 406. See *id.* at col. 3:56-61. The selected output is forwarded to summing circuit **403**, the output of which is converted by synchronous detector and filter circuit **404** to a signal related to the capacitance of the row or column selected by the multiplexer. See *id.* at col. 3:62-67. The RF oscillator **408** provides an RF signal of, for example ,100 KiloHertz, to circuits **401**, synchronous detector and filter circuit **404** via inverter **410**, and guard plane **411**, which is a substantially continuous plane parallel to array **100** and associated connections, and serves to isolate array **100** from extraneous signals. See *id.* at col. 3:67 - col. 4:5. To measure separate capacitance values for each electrode in array **100** instead of the collective capacitances of subdivided electrode elements connected in rows and columns, a circuit **401** is provided for each electrode in array **100** and multiplexer **402** is enlarged to accommodate the outputs from all circuits **401**. See *id.* at col. 4:14-21. The output of

synchronous detector and filter **404** is converted to digital form by analog-to-digital converter **405** and forwarded to microcontroller **406** so that microcontroller 406 obtains a digital value representing the capacitance seen by any row or column of electrode elements (or electrode if measured separately) selected by multiplexer **402**. *See id.* at col. 4:22-28. Particularly, Boie discloses driving the electrodes of electrode array 100 and guard planes 411 with a single RF signal for minimizing the effects of electrode-to-electrode capacitances, wiring capacitances and other extraneous capacitances. *See id.* at col. 4:58-61.

Thus, Boie does not teach or suggest the microcontroller is used to selectively providing signal output frequencies to input touch terminals of a keypad.

Accordingly, Boie does not teach or suggest the above-identified underlined claimed features.

Gerpheide

Gerpheide teaches a system and method for a capacitance-based proximity sensor with interference rejection. *See* Abstract. The system **10** comprises an electrode array **12**, a synchronous electrode capacitance measurement unit **14**, a reference frequency generator **16**, and a position locator **18**. *See id.* at Figure 1, and col. 3:52 to col. 4:26. The electrode array consists of multiple X electrodes **20** and Y electrodes **22**. *See id.* at Figures 2A and 2B. The synchronous electrode capacitance measurement unit **14** is connected to the electrode array **12** and the reference frequency generator **16** for producing capacitive measurement signals. *See id.* at Figure 4, and col. 5:50-67. Particularly, Gerpheide teaches that the reference frequency generator **16** includes an oscillator **100** for driving a microcontroller **102** and a divide-by-(M+N) circuit **104**, for providing signal output frequencies and always selecting a reference frequency away from frequencies which have been found to result in measurement interference; wherein, N

is a fixed constant, approximately 50, and M is specified by the microcontroller **102** to be, for example, one of four values in the ranges 61 KHz to 80 KHz as specified by the microcontroller **102**; and wherein, the microcontroller **102** performs the functions of interference evaluation 106 and frequency selection 108. See *id.* at Figure 7, and col. 8:20-43.

Thus, Gerpheide does not teach or suggest the synchronous electrode capacitance measurement unit is responsive to signals from the oscillator via said microcontroller and the presence of an operator's body capacitance to ground.

Accordingly, Gerpheide does not teach or suggest the above-identified underlined claimed features.

Casio

Casio teaches a Casio Calculator Watch, which is a timepiece product employing electro-touch technology. The watch works by reading finger-strokes traced across its face. See *id.* at col. 1. The transparent touch panel construction includes a fiberglass panel having a transparent conductor film pattern (first layer) and a dielectric layer (second layer) overlying the fiberglass. See *id.* at col. 2. The touch panel determines figure and math symbols outlined with finger-strokes traced across the face. See *id.* at col. 1. The touch panel senses the input, and then digitizes it to extract features of the figure or math symbol. See *id.* at col. 2. The watch then outputs the corresponding figure or math symbol on the screen.

Thus, Casio does not teach or suggest the microcontroller is used to selectively providing signal output frequencies to input touch terminals of a keypad.

Accordingly, Casio does not teach or suggest the above-identified underlined claimed features.

Lee

Lee discloses a fast-scanning multiple-touch-sensitive input device comprising: a sensor matrix board, row and column selection registers, A/D converting circuits and a dedicated CPU. *See id.* at Figure 3.4. The row selection registers select one or more rows by setting the corresponding bits to a high state in order to charge up the sensors while the column selection registers select one or more columns by turn on corresponding analog switches to discharge the sensors through timing resistors. The intersecting region of the selected rows and the selected columns represents the selected sensors as a unit. *See id.* at Figure 3.1(a) shows a model of a selected sensor in the sensor matrix, Figure 3.1 (b) shows the timing diagram for discharging time measurement of a selected sensor, and Figure 3.2 illustrates a small section of a sensor matrix. Particularly, Lee describes the interface between the CPU and the sensor matrix as follows: The CPU selects the row or rows of a sensor group, initiating charging of all the associated sensors. After a charging interval, the CPU discharges the selected column or columns corresponding to a sensor group by connecting a group of discharge resistors whose current is summed via a high slew rate operational amplifier. Wherein, the CPU selects or deselects the row(s) by sending binary signals to the selected row(s). *See id.* at Figs. 3.1(a), 3.1(b), and 3.4, and page 3-10. As illustrated by the data bus of Figure 3.4.

Thus, Lee does not teach or suggest sending signal output frequencies to the selected rows and/or column.

Accordingly, Lee does not teach or suggest the above-identified underlined claimed features.

Further, the examiner agrees with the discussion articulated by patent owner that the prior art references, Boie, Gerpheide, Lee, and Casio, either alone or in combinations, fails to teach the above-identified claimed, see the response pages 16-20.

Accordingly, the independent claims 45, 56, 72, 84, 95, 106, and 111 are patentable over the prior art references of Boie, Gerpheide, Lee, and Casio.

Dependent claims 40-44, 46-55, 57-71, 73-83, 85-94, 96-105, 107-110, and 112-117, each is dependent upon one of said independent claims, and it is patentable based on at least the reasons set forth for the independent claim due to its dependency.

Any comments considered necessary by PATENT OWNER regarding the above statement must be submitted promptly to avoid processing delays. Such submission by the patent owner should be labeled: "Comments on Statement of Reasons for Patentability and/or Confirmation" and will be placed in the reexamination file.

CLAIM RENUMBERS

6. Claims 40-117 are renumbered consecutively in compliance with 37 CFR 1.126 and 37 CFR 1.530(g), see MPEP 608.01(j) and MPEP § 2250, as shown in the table below.

Art Unit: 3992

Claims renumbered in the same order as presented by applicant															
CPA															
T.D.															
R.1.47															
Final	Original	Final	Original	Final	Original	Final	Original	Final	Original	Final	Original	Final	Original	Final	Original
1	1		18		35	50	52	109	59	85	85	103	103		
2	2	19	19	36	36	53	53	110	70	87	87	104	104		
3	3	20	20	37	37	54	54	111	71	88	88	105	105		
4	4	21	21	38	38	55	55	71	72	87	89	49	106		
5	5	22	22	39	39	61	61	73	73	90	90	45	107		
6	6	23	23	40	40	62	62	74	74	91	91	47	108		
7	7	24	24	41	41	63	63	75	75	92	92	48	109		
8	8	25	25	42	42	65	65	76	76	93	93	49	110		
9	9	26	26	43	43	67	67	77	77	94	94	105	111		
10	10		27	44	44	68	68	78	78	94	95	112	112		
11	11	28	28	50	45	69	82	79	79	95	95	113	113		
12	12	29	29	51	46	70	83	72	80	97	97	114	114		
13	13	30	30	52	47	64	64	80	81	98	98	115	115		
14	14	31	31	53	48	65	65	81	82	98	98	116	116		
15	15	32	32	57	49	106	66	82	83	100	100	117	117		
16	16	33	33	58	50	107	67	83	84	101	101				
17	17	34	34	55	51	108	68	85	85	102	102				

CONCLUSION

7. Extensions of Time

Extensions of time under 37 CFR 1.136(a) will not be permitted in these proceedings because the provisions of 37 CFR 1.136 apply only to "an applicant" and not to parties in a reexamination proceeding. Additionally, 35 U.S.C. 305 requires that reexamination proceedings "will be conducted with special dispatch" (37 CFR 1.550(a)). Extension of time in *ex parte* reexamination proceedings are provided for in 37 CFR 1.550(c).

8. Litigation Reminder

The patent owner is reminded of the continuing responsibility under 37 CFR 1.565(a) to apprise the Office of any litigation activity, or other prior or concurrent proceeding, involving the '183

patent throughout the course of this reexamination proceeding. See MPEP §§ 2207, 2282 and 2286.

9. Correspondence and Inquiry as to Office Actions

All correspondence related to this ex parte reexamination proceeding should be directed as follows:

By EFS: Registered users may submit via the electronic filing system EFS-Web, at <https://efs.uspto.gov/efile/myportal/efs-registered>

By Mail to: Mail Stop *Ex Parte* Reexam
Central Reexamination Unit
Commissioner for Patents
United States Patent & Trademark Office
P.O. Box 1450
Alexandria, VA 22313-1450

By FAX to: (571) 273-9900
Central Reexamination Unit

By hand: Customer Service Window
Randolph Building
401 Dulany Street
Alexandria, VA 2231

For EFS-Web transmissions, 37 CFR 1.8(a)(1)(i) (C) and (ii) states that correspondence (except for a request for reexamination and a corrected or replacement request for reexamination) will be considered timely filed if (a) it is transmitted via the Office's electronic filing system in accordance with 37 CFR 1.6(a)(4), and (b) includes a certificate of transmission for each piece of correspondence stating the data of transmission, which is prior to the expiration of the set period of time in the Office action.

Art Unit: 3992

Any inquiry by the patent owner concerning this communication or earlier communications from the Legal Advisor or Examiner, or as to the status of this proceeding, should be directed to the Central Reexamination Unit at telephone number (571) 272-7705.

Signed:

/Henry N Tran/
Patent Reexamination Specialist,
CRU - Art Unit 3992

Conferees:

//
Patent Reexamination Specialist,
CRU - Art Unit 3992

//
Supervisory Patent Examiner, Art Unit 3992

Issue Classification 	Application/Control No. 90013106	Applicant(s)/Patent Under Reexamination 5796183
	Examiner HENRY N TRAN	Art Unit 3992

<input type="checkbox"/> Claims renumbered in the same order as presented by applicant <input type="checkbox"/> CPA <input type="checkbox"/> T.D. <input type="checkbox"/> R.1.47															
Final	Original	Final	Original	Final	Original	Final	Original	Final	Original	Final	Original	Final	Original	Final	Original
1	1		18		35	60	52	109	69	86	86	103	103		
2	2	19	19	36	36	53	53	110	70	87	87	104	104		
3	3	20	20	37	37	54	54	111	71	88	88	95	105		
4	4	21	21	38	38	55	55	71	72	89	89	40	106		
5	5	22	22	38	39	61	56	73	73	90	90	46	107		
6	6	23	23	45	40	62	57	74	74	91	91	47	108		
7	7	24	24	41	41	63	58	75	75	92	92	48	109		
8	8	25	25	42	42	66	59	76	76	93	93	49	110		
9	9	26	26	43	43	67	60	77	77	84	94	105	111		
10	10		27	44	44	68	61	78	78	94	95	112	112		
11	11	28	28	50	45	69	62	79	79	96	96	113	113		
12	12	29	29	51	46	70	63	72	80	97	97	114	114		
13	13	30	30	52	47	64	64	80	81	98	98	115	115		
14	14	31	31	56	48	65	65	81	82	99	99	116	116		
15	15	32	32	57	49	106	66	82	83	100	100	117	117		
16	16	33	33	58	50	107	67	83	84	101	101				
17	17	34	34	59	51	108	68	85	85	102	102				

NONE		Total Claims Allowed:	
		78	
(Assistant Examiner)	(Date)		
/HENRY N TRAN/ Primary Examiner. Art Unit 3992	06/03/2014	O.G. Print Claim(s)	O.G. Print Figure
(Primary Examiner)	(Date)	40	4



UNITED STATES PATENT AND TRADEMARK OFFICE

UNITED STATES DEPARTMENT OF COMMERCE
 United States Patent and Trademark Office
 Address: COMMISSIONER FOR PATENTS
 P.O. Box 1450
 Alexandria, Virginia 22313-1450
 www.uspto.gov

BIB DATA SHEET

CONFIRMATION NO. 9188

SERIAL NUMBER 90/013,106	FILING or 371(c) DATE 12/24/2013 RULE	CLASS 307	GROUP ART UNIT 3992	ATTORNEY DOCKET NO. NAR-5796183RX2		
APPLICANTS						
INVENTORS 5796183, Residence Not Provided; NARTRON CORPORATION, REED CITY, MI;						
** CONTINUING DATA ***** This application is a REX of 08/601,268 01/31/1996 PAT 5796183						
** FOREIGN APPLICATIONS *****						
** IF REQUIRED, FOREIGN FILING LICENSE GRANTED ** ** SMALL ENTITY **						
Foreign Priority claimed <input type="checkbox"/> Yes <input checked="" type="checkbox"/> No	35 USC 119(a-d) conditions met <input type="checkbox"/> Yes <input checked="" type="checkbox"/> No	<input type="checkbox"/> Met after Allowance Initials _____	STATE OR COUNTRY	SHEETS DRAWINGS	TOTAL CLAIMS 14	INDEPENDENT CLAIMS 110
ADDRESS SLATER & MATSIL, L.L.P. 17950 PRESTON RD, SUITE 1000 DALLAS, TX 75252-5793 UNITED STATES						
TITLE Capacitive Responsive Electronic Switching Circuit						
FILING FEE RECEIVED 6000	FEES: Authority has been given in Paper No. _____ to charge/credit DEPOSIT ACCOUNT No. _____ for following:		<input type="checkbox"/> All Fees <input type="checkbox"/> 1.16 Fees (Filing) <input type="checkbox"/> 1.17 Fees (Processing Ext. of time) <input type="checkbox"/> 1.18 Fees (Issue) <input type="checkbox"/> Other _____ <input type="checkbox"/> Credit			

Reexamination 	Application/Control No. 90013106	Applicant(s)/Patent Under Reexamination 5796183
	Certificate Date 04/29/2013	Certificate Number 5796183C1

Requester Correspondence Address:	<input checked="" type="checkbox"/> Patent Owner	<input type="checkbox"/> Third Party
SLATER & MATSIL, L.L.P. 17950 PRESTON RD, SUITE 1000 DALLAS, TX 75252-5793		

LITIGATION REVIEW <input checked="" type="checkbox"/>	/HT/ (examiner initials)	01/26/2014 (date)
Case Name		Director Initials
1:06cv 1777 - CLOSED		
2:03cv75169 - CLOSED		
1:10cv691 - CLOSED		
2:06cv500 -CLOSED		

COPENDING OFFICE PROCEEDINGS	
TYPE OF PROCEEDING	NUMBER
1. NONE	

--	--

Search Notes 	Application/Control No. 90013106	Applicant(s)/Patent Under Reexamination 5796183
	Examiner HENRY N TRAN	Art Unit 3992

CPC- SEARCHED		
Symbol	Date	Examiner

CPC COMBINATION SETS - SEARCHED		
Symbol	Date	Examiner

US CLASSIFICATION SEARCHED			
Class	Subclass	Date	Examiner
307	112,113,116,125,139,140,157	6/2/2014	HT
361	181	6/2/2014	HT

SEARCH NOTES		
Search Notes	Date	Examiner
Review of patented file's prosecution history	03/102014/	HT
Review of patented file's prosecution history	05/30 & 06/02/14	HT

INTERFERENCE SEARCH			
US Class/ CPC Symbol	US Subclass / CPC Group	Date	Examiner
307	112,113,116,125,139,140,157	6/2/14	HT
361	181	6/2/14	HT

	/HENRY N TRAN/ Primary Examiner.Art Unit 3992
--	--

Index of Claims 	Application/Control No. 90013106	Applicant(s)/Patent Under Reexamination 5796183
	Examiner HENRY N TRAN	Art Unit 3992

✓	Rejected	-	Cancelled	N	Non-Elected	A	Appeal
=	Allowed	÷	Restricted	I	Interference	O	Objected

Claims renumbered in the same order as presented by applicant
 CPA
 T.D.
 R.1.47

CLAIM		DATE							
Final	Original	03/20/2014	06/03/2014						
1	1	N	N						
2	2	N	N						
3	3	N	N						
4	4	N	N						
5	5	N	N						
6	6	N	N						
7	7	N	N						
8	8	N	N						
9	9	N	N						
10	10	N	N						
11	11	N	N						
12	12	N	N						
13	13	N	N						
14	14	N	N						
15	15	N	N						
16	16	N	N						
17	17	N	N						
	18	✓	-						
19	19	N	N						
20	20	N	N						
21	21	N	N						
22	22	N	N						
23	23	N	N						
24	24	N	N						
25	25	N	N						
26	26	N	N						
	27	✓	-						
28	28	N	N						
29	29	N	N						
30	30	N	N						
31	31	N	N						
32	32	N	N						
33	33	N	N						
34	34	N	N						
	35	-	-						
36	36	N	N						

Index of Claims 	Application/Control No. 90013106	Applicant(s)/Patent Under Reexamination 5796183
	Examiner HENRY N TRAN	Art Unit 3992

✓	Rejected	-	Cancelled	N	Non-Elected	A	Appeal
=	Allowed	÷	Restricted	I	Interference	O	Objected

Claims renumbered in the same order as presented by applicant
 CPA
 T.D.
 R.1.47

CLAIM		DATE							
Final	Original	03/20/2014	06/03/2014						
37	37	N	N						
38	38	N	N						
39	39	N	N						
45	40	✓	=						
41	41	✓	=						
42	42	✓	=						
43	43	✓	=						
44	44	✓	=						
50	45	=	=						
51	46	=	=						
52	47	=	=						
56	48	=	=						
57	49	=	=						
58	50	=	=						
59	51	=	=						
60	52	=	=						
53	53	=	=						
54	54	=	=						
55	55	=	=						
61	56	✓	=						
62	57	✓	=						
63	58	✓	=						
66	59	✓	=						
67	60	✓	=						
68	61	✓	=						
69	62	✓	=						
70	63	✓	=						
64	64	✓	=						
65	65	✓	=						
106	66	✓	=						
107	67	✓	=						
108	68	✓	=						
109	69	✓	=						
110	70	✓	=						
111	71	✓	=						
71	72	=	=						

Index of Claims 	Application/Control No. 90013106	Applicant(s)/Patent Under Reexamination 5796183
	Examiner HENRY N TRAN	Art Unit 3992

✓	Rejected	-	Cancelled	N	Non-Elected	A	Appeal
=	Allowed	÷	Restricted	I	Interference	O	Objected

Claims renumbered in the same order as presented by applicant
 CPA
 T.D.
 R.1.47

CLAIM		DATE							
Final	Original	03/20/2014	06/03/2014						
73	73	=	=						
74	74	=	=						
75	75	=	=						
76	76	=	=						
77	77	=	=						
78	78	=	=						
79	79	=	=						
72	80	=	=						
80	81	=	=						
81	82	=	=						
82	83	=	=						
83	84	=	=						
85	85	=	=						
86	86	=	=						
87	87	=	=						
88	88	=	=						
89	89	=	=						
90	90	=	=						
91	91	=	=						
92	92	=	=						
93	93	=	=						
84	94	=	=						
94	95	✓	=						
96	96	✓	=						
97	97	✓	=						
98	98	✓	=						
99	99	✓	=						
100	100	✓	=						
101	101	✓	=						
102	102	✓	=						
103	103	✓	=						
104	104	✓	=						
95	105	✓	=						
40	106		=						
46	107		=						
47	108		=						

<i>Index of Claims</i> 	Application/Control No. 90013106	Applicant(s)/Patent Under Reexamination 5796183
	Examiner HENRY N TRAN	Art Unit 3992

✓	Rejected	-	Cancelled	N	Non-Elected	A	Appeal
=	Allowed	÷	Restricted	I	Interference	O	Objected

Claims renumbered in the same order as presented by applicant
 CPA
 T.D.
 R.1.47

CLAIM		DATE							
Final	Original	03/20/2014	06/03/2014						
48	109		=						
49	110		=						
105	111		=						
112	112		=						
113	113		=						
114	114		=						
115	115		=						
116	116		=						
117	117		=						



US005796183C2

(12) **EX PARTE REEXAMINATION CERTIFICATE** (10211th)
United States Patent
Hourmand et al.

(10) **Number:** **US 5,796,183 C2**
(45) **Certificate Issued:** **Jun. 27, 2014**

(54) **CAPACITIVE RESPONSIVE ELECTRONIC SWITCHING CIRCUIT**

(75) Inventors: **Byron Hourmand**, Hersey, MI (US);
John M. Washeleski, Cadillac, MI (US);
Stephen R. W. Cooper, Fowlerville, MI (US)

(73) Assignee: **Nartron Corporation**, Reed City, MI (US)

Reexamination Request:
No. 90/013,106, Dec. 24, 2013

Reexamination Certificate for:
Patent No.: **5,796,183**
Issued: **Aug. 18, 1998**
Appl. No.: **08/601,268**
Filed: **Jan. 31, 1996**

Reexamination Certificate C1 5,796,183 issued Apr. 29, 2013

Certificate of Correction issued May 11, 1999

Certificate of Correction issued Oct. 11, 2011

(51) **Int. Cl.**
H03K 17/96 (2006.01)
H03K 17/94 (2006.01)
(52) **U.S. Cl.**
USPC **307/116; 307/125; 307/139; 307/140;**
307/112; 307/113; 361/181

(58) **Field of Classification Search**
USPC 307/112, 113, 116, 125, 139, 140, 157;
361/181
See application file for complete search history.

(56) **References Cited**

To view the complete listing of prior art documents cited during the proceeding for Reexamination Control Number 90/013,106, please refer to the USPTO's public Patent Application Information Retrieval (PAIR) system under the Display References tab.

Primary Examiner — Henry N Tran

(57) **ABSTRACT**

A capacitive responsive electronic switching circuit comprises an oscillator providing a periodic output signal having a frequency of 50 kHz or greater, an input touch terminal defining an area for an operator provide an input by proximity and touch, and a detector circuit coupled to the oscillator for receiving the periodic output signal from the oscillator, and coupled to the input touch terminal. The detector circuit being responsive to signals from the oscillator and the presence of an operator's body capacitance to ground coupled to the touch terminal when in proximity or touched by an operator to provide a control output signal. Preferably, the oscillator provides a periodic output signal having a frequency of 800 kHz or greater. An array of touch terminals may be provided in close proximity due to the reduction in crosstalk that may result from contaminants by utilizing an oscillator outputting a signal having a frequency of 50 kHz or greater.

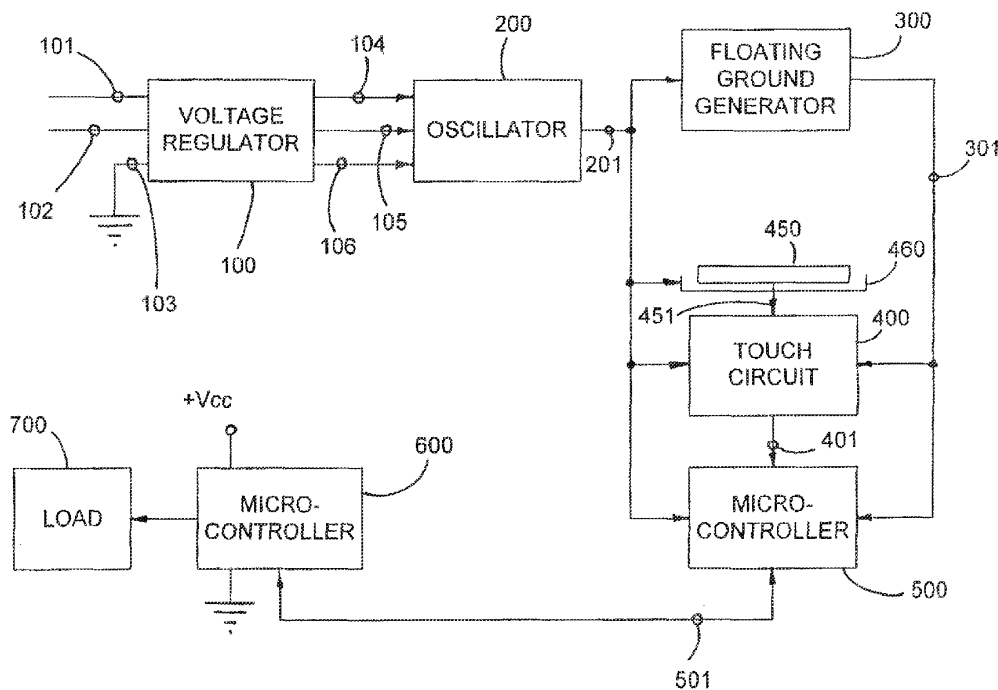

1
EX PARTE
REEXAMINATION CERTIFICATE
ISSUED UNDER 35 U.S.C. 307

THE PATENT IS HEREBY AMENDED AS
INDICATED BELOW.

Matter enclosed in heavy brackets [] appeared in the patent, but has been deleted and is no longer a part of the patent; matter printed in italics indicates additions made to the patent.

AS A RESULT OF REEXAMINATION, IT HAS BEEN DETERMINED THAT:

Claims 18, 27 and 35 are cancelled.

New claims 40-117 are added and determined to be patentable.

Claims 1-17, 19-26, 28-34 and 36-39 were not reexamined.

40. *A capacitive responsive electronic switching circuit comprising:*

an oscillator providing a periodic output signal having a predefined frequency;

a microcontroller using the periodic output signal from the oscillator, the microcontroller selectively providing signal output frequencies to a plurality of small sized input touch terminals of a keypad, wherein the selectively providing comprises the microcontroller selectively providing a signal output frequency to each row of the plurality of small sized input touch terminals of the keypad;

the plurality of small sized input touch terminals defining adjacent areas on a dielectric substrate for an operator to provide inputs by proximity and touch; and

a detector circuit coupled to said oscillator for receiving said periodic output signal from said oscillator, and coupled to said input touch terminals, said detector circuit being responsive to signals from said oscillator via said microcontroller and a presence of an operator's body capacitance to ground coupled to said touch terminals when proximal or touched by the operator to provide a control output signal,

wherein said predefined frequency of said oscillator and said signal output frequencies are selected to decrease a first impedance of said dielectric substrate relative to a second impedance of any contaminate that may create an electrical path on said dielectric substrate between said adjacent areas defined by the plurality of small sized input touch terminals, and wherein said detector circuit compares a sensed body capacitance change to ground proximate an input touch terminal to a threshold level to prevent inadvertent generation of the control output signal.

41. *The capacitive responsive electronic switching circuit as defined in claim 40, wherein each signal output frequency selectively provided to each row of the plurality of small sized input touch terminals of the keypad is selected from a plurality of Hertz values.*

42. *The capacitive responsive electronic switching circuit as defined in claim 41, wherein the plurality of Hertz values comprises Hertz values greater than 50 kHz.*

43. *The capacitive responsive electronic switching circuit as defined in claim 41, wherein the plurality of Hertz values comprises Hertz values greater than 100 kHz.*

2

44. *The capacitive responsive electronic switching circuit as defined in claim 41, wherein the plurality of Hertz values comprises Hertz values greater than 800 kHz.*

45. *The capacitive responsive electronic switching circuit as defined in claim 40, wherein each signal output frequency selectively provided to each row of the plurality of small sized input touch terminals of the keypad has a same Hertz value.*

46. *The capacitive responsive switching circuit as defined in claim 40, wherein said oscillator provides a periodic output signal having a frequency of 800 kHz or greater.*

47. *The capacitive responsive electronic switching circuit as defined in claim 40, wherein the sensed body capacitance change to ground proximate the input touch terminal is caused by the operator's body capacitance decreasing an input touch terminal signal on the detector circuit, and wherein the sensed body capacitance change to ground is compared to a second threshold level to generate the control output signal.*

48. *The capacitive responsive electronic switching circuit as defined in claim 40, wherein the sensed body capacitance change to ground proximate the input touch terminal is caused by the operator's body capacitance decreasing an input touch terminal signal amplitude on the detector circuit, and wherein the sensed body capacitance change to ground is compared to a second threshold level to generate the control output signal.*

49. *The capacitive responsive electronic switching circuit as defined in claim 40, wherein the detector circuit comprises a plurality of touch circuits, and wherein the microcontroller selectively provides the signal output frequencies to the plurality of small sized input touch terminals of the keypad via the plurality of touch circuits.*

50. *A capacitive responsive electronic switching circuit comprising:*

an oscillator providing a periodic output signal having a predefined frequency;

a microcontroller using the periodic output signal from the oscillator, the microcontroller selectively providing signal output frequencies directly to a plurality of small sized input touch terminals of a keypad;

the plurality of small sized input touch terminals defining adjacent areas on a dielectric substrate for an operator to provide inputs by proximity and touch; and

a detector circuit coupled to said oscillator for receiving said periodic output signal from said oscillator, and coupled to said input touch terminals, said detector circuit being responsive to signals from said oscillator via said microcontroller and a presence of an operator's body capacitance to ground coupled to said touch terminals when proximal or touched by the operator to provide a control output signal,

wherein said predefined frequency of said oscillator and said signal output frequencies are selected to decrease a first impedance of said dielectric substrate relative to a second impedance of any contaminate that may create an electrical path on said dielectric substrate between said adjacent areas defined by the plurality of small sized input touch terminals, and wherein said detector circuit compares a sensed body capacitance change to ground proximate an input touch terminal to a threshold level to prevent inadvertent generation of the control output signal.

51. *The capacitive responsive electronic switching circuit as defined in claim 50, wherein the sensed body capacitance change to ground proximate the input touch terminal is caused by the operator's body capacitance decreasing an input touch terminal signal on the detector circuit, and*

3

wherein the sensed body capacitance change to ground is compared to a second threshold level to generate the control output signal.

52. The capacitive responsive electronic switching circuit as defined in claim 50, wherein the sensed body capacitance change to ground proximate the input touch terminal is caused by the operator's body capacitance decreasing an input touch terminal signal amplitude on the detector circuit, and wherein the sensed body capacitance change to ground is compared to a second threshold level to generate the control output signal.

53. The capacitive responsive electronic switching circuit as defined in claim 50, wherein a peak voltage of the signal output frequencies is greater than a supply voltage.

54. The capacitive responsive electronic switching circuit as defined in claim 53, wherein the supply voltage is a battery supply voltage.

55. The capacitive responsive electronic switching circuit as defined in claim 53, wherein the supply voltage is a voltage regulator supply voltage.

56. The capacitive responsive electronic switching circuit as defined in claim 50, wherein the signal output frequencies have a same Hertz value.

57. The capacitive responsive electronic switching circuit as defined in claim 50, wherein each signal output frequency is selected from a plurality of Hertz values.

58. The capacitive responsive electronic switching circuit as defined in claim 57, wherein the plurality of Hertz values comprises Hertz values greater than 50 kHz.

59. The capacitive responsive electronic switching circuit as defined in claim 57, wherein the plurality of Hertz values comprises Hertz values greater than 100 kHz.

60. The capacitive responsive electronic switching circuit as defined in claim 57, wherein the plurality of Hertz values comprises Hertz values greater than 800 kHz.

61. A capacitive responsive electronic switching circuit comprising:

an oscillator providing a periodic output signal having a predefined frequency;

a microcontroller using the periodic output signal from the oscillator, the microcontroller selectively providing signal output frequencies to a plurality of small sized input touch terminals of a keypad, wherein the selectively providing comprises the microcontroller selectively providing a signal output frequency to each row of the plurality of small sized input touch terminals of the keypad, and wherein a peak voltage of the signal output frequencies is greater than a supply voltage;

the plurality of small sized input touch terminals defining adjacent areas on a dielectric substrate for an operator to provide inputs by proximity and touch; and

a detector circuit coupled to said oscillator for receiving said periodic output signal from said oscillator, and coupled to said input touch terminals, said detector circuit being responsive to signals from said oscillator via said microcontroller and a presence of an operator's body capacitance to ground coupled to said touch terminals when proximal or touched by the operator to provide a control output signal,

wherein said predefined frequency of said oscillator and said signal output frequencies are selected to decrease a first impedance of said dielectric substrate relative to a second impedance of any contaminate that may create an electrical path on said dielectric substrate between said adjacent areas defined by the plurality of small sized input touch terminals, and wherein said detector circuit compares a sensed body capacitance change to

4

ground proximate an input touch terminal to a threshold level to prevent inadvertent generation of the control output signal.

62. The capacitive responsive electronic switching circuit as defined in claim 61, wherein the sensed body capacitance change to ground proximate the input touch terminal is caused by the operator's body capacitance decreasing an input touch terminal signal on the detector circuit, and wherein the sensed body capacitance change to ground is compared to a second threshold level to generate the control output signal.

63. The capacitive responsive electronic switching circuit as defined in claim 61, wherein the sensed body capacitance change to ground proximate the input touch terminal is caused by the operator's body capacitance decreasing an input touch terminal signal amplitude on the detector circuit, and wherein the sensed body capacitance change to ground is compared to a second threshold level to generate the control output signal.

64. The capacitive responsive electronic switching circuit as defined in claim 61, wherein the supply voltage is a battery supply voltage.

65. The capacitive responsive electronic switching circuit as defined in claim 61, wherein the supply voltage is a voltage regulator supply voltage.

66. The capacitive responsive electronic switching circuit as defined in claim 61, wherein each signal output frequency selectively provided to each row of the plurality of small sized input touch terminals of the keypad has a same Hertz value.

67. The capacitive responsive electronic switching circuit as defined in claim 61, wherein each signal output frequency selectively provided to each row of the plurality of small sized input touch terminals of the keypad is selected from a plurality of Hertz values.

68. The capacitive responsive electronic switching circuit as defined in claim 67, wherein the plurality of Hertz values comprises Hertz values greater than 50 kHz.

69. The capacitive responsive electronic switching circuit as defined in claim 67, wherein the plurality of Hertz values comprises Hertz values greater than 100 kHz.

70. The capacitive responsive electronic switching circuit as defined in claim 67, wherein the plurality of Hertz values comprises Hertz values greater than 800 kHz.

71. A capacitive responsive electronic switching circuit for a controlled keypad device comprising:

an oscillator providing a periodic output signal having a predefined frequency;

a microcontroller using the periodic output signal from the oscillator, the microcontroller selectively providing signal output frequencies directly to a closely spaced array of input touch terminals of a keypad, the input touch terminals comprising first and second input touch terminals;

the first and second input touch terminals defining areas for an operator to provide an input by proximity and touch; and

a detector circuit coupled to said oscillator for receiving said periodic output signal from said oscillator, and coupled to said first and second touch terminals, said detector circuit being responsive to signals from said oscillator via said microcontroller and a presence of an operator's body capacitance to ground coupled to said first and second touch terminals when proximal or touched by the operator to provide a control output signal for actuation of the controlled keypad device, said detector circuit being configured to generate said control output signal when the operator is proximal or

5

touches said second touch terminal after the operator is proximal or touches said first touch terminal.

72. *The capacitive responsive electronic switching circuit as defined in claim 71, wherein the detector circuit is configured to inhibit the control output signal unless the operator is proximal or touches said second touch terminal after the operator is proximal or touches said first touch terminal.*

73. *The capacitive responsive electronic switching circuit as defined in claim 71, wherein the signal output frequencies have a same Hertz value.*

74. *The capacitive responsive electronic switching circuit as defined in claim 71, wherein each signal output frequency is selected from a plurality of Hertz values.*

75. *The capacitive responsive electronic switching circuit as defined in claim 74, wherein the plurality of Hertz values comprises Hertz values greater than 50 kHz.*

76. *The capacitive responsive electronic switching circuit as defined in claim 74, wherein the plurality of Hertz values comprises Hertz values greater than 100 kHz.*

77. *The capacitive responsive electronic switching circuit as defined in claim 74, wherein the plurality of Hertz values comprises Hertz values greater than 800 kHz.*

78. *The capacitive responsive electronic switching circuit as defined in claim 71, wherein said detector circuit is configured to generate said control output signal only when the operator is proximal or touches said second touch terminal within a predetermined time period after the operator is proximal or touches said first touch terminal.*

79. *The capacitive responsive electronic switching circuit as defined in claim 71, further comprising an indicator for indicating the detector circuit has determined that the operator is proximal or touches said second touch terminal.*

80. *The capacitive responsive electronic switching circuit as defined in claim 71, wherein a peak voltage of the signal output frequencies is greater than a supply voltage.*

81. *The capacitive responsive electronic switching circuit as defined in claim 80, wherein the supply voltage is a battery supply voltage.*

82. *The capacitive responsive electronic switching circuit as defined in claim 80, wherein the supply voltage is a voltage regulator supply voltage.*

83. *A capacitive responsive electronic switching circuit for a controlled keypad device comprising:*

an oscillator providing a periodic output signal having a predefined frequency;

a microcontroller using the periodic output signal from the oscillator, the microcontroller selectively providing signal output frequencies to a closely spaced array of input touch terminals of a keypad, the input touch terminals comprising first and second input touch terminals, wherein a peak voltage of the signal output frequencies is greater than a supply voltage;

the first and second input touch terminals defining areas for an operator to provide an input by proximity and touch; and

a detector circuit coupled to said oscillator for receiving said periodic output signal from said oscillator, and coupled to said first and second touch terminals, said detector circuit being responsive to signals from said oscillator via said microcontroller and a presence of an operator's body capacitance to ground coupled to said first and second touch terminals when proximal or touched by the operator to provide a control output signal for actuation of the controlled keypad device, said detector circuit being configured to generate said control output signal when the operator is proximal or

6

touches said second touch terminal after the operator is proximal or touches said first touch terminal.

84. *The capacitive responsive electronic switching circuit as defined in claim 83, wherein the detector circuit is configured to inhibit the control output signal unless the operator is proximal or touches said second touch terminal after the operator is proximal or touches said first touch terminal.*

85. *The capacitive responsive electronic switching circuit as defined in claim 83, wherein the signal output frequencies have a same Hertz value.*

86. *The capacitive responsive electronic switching circuit as defined in claim 83, wherein each signal output frequency is selected from a plurality of Hertz values.*

87. *The capacitive responsive electronic switching circuit as defined in claim 86, wherein the plurality of Hertz values comprises Hertz values greater than 50 kHz.*

88. *The capacitive responsive electronic switching circuit as defined in claim 86, wherein the plurality of Hertz values comprises Hertz values greater than 100 kHz.*

89. *The capacitive responsive electronic switching circuit as defined in claim 86, wherein the plurality of Hertz values comprises Hertz values greater than 800 kHz.*

90. *The capacitive responsive electronic switching circuit as defined in claim 83, wherein the supply voltage is a battery supply voltage.*

91. *The capacitive responsive electronic switching circuit as defined in claim 83, wherein the supply voltage is a voltage regulator supply voltage.*

92. *The capacitive responsive electronic switching circuit as defined in claim 83, wherein said detector circuit is configured to generate said control output signal only when the operator is proximal or touches said second touch terminal within a predetermined time period after the operator is proximal or touches said first touch terminal.*

93. *The capacitive responsive electronic switching circuit as defined in claim 83, further comprising an indicator for indicating the detector circuit has determined that the operator is proximal or touches said second touch terminal.*

94. *A capacitive responsive electronic switching circuit for a controlled keypad device comprising:*

an oscillator providing a periodic output signal having a predefined frequency;

a microcontroller using the periodic output signal from the oscillator, the microcontroller selectively providing signal output frequencies to a closely spaced array of input touch terminals of a keypad, wherein the selectively providing comprises the microcontroller selectively providing a signal output frequency to each row of the closely spaced array of input touch terminals of the keypad, the input touch terminals comprising first and second input touch terminals, and wherein a peak voltage of the signal output frequencies is greater than a supply voltage;

the first and second input touch terminals defining areas for an operator to provide an input by proximity and touch; and

a detector circuit coupled to said oscillator for receiving said periodic output signal from said oscillator, and coupled to said first and second touch terminals, said detector circuit being responsive to signals from said oscillator via said microcontroller and a presence of an operator's body capacitance to ground coupled to said first and second touch terminals when proximal or touched by the operator to provide a control output signal for actuation of the controlled keypad device, said detector circuit being configured to generate said control output signal when the operator is proximal or

touches said second touch terminal after the operator is proximal or touches said first touch terminal.

95. The capacitive responsive electronic switching circuit as defined in claim 94, wherein the detector circuit is configured to inhibit the control output signal unless the operator is proximal or touches said second touch terminal after the operator is proximal or touches said first touch terminal.

96. The capacitive responsive electronic switching circuit as defined in claim 94, wherein each signal output frequency selectively provided to each row of the closely spaced array of input touch terminals of the keypad has a same Hertz value.

97. The capacitive responsive electronic switching circuit as defined in claim 94, wherein each signal output frequency selectively provided to each row of the closely spaced array of input touch terminals of the keypad is selected from a plurality of Hertz values.

98. The capacitive responsive electronic switching circuit as defined in claim 97, wherein the plurality of Hertz values comprises Hertz values greater than 50 kHz.

99. The capacitive responsive electronic switching circuit as defined in claim 97, wherein the plurality of Hertz values comprises Hertz values greater than 100 kHz.

100. The capacitive responsive electronic switching circuit as defined in claim 97, wherein the plurality of Hertz values comprises Hertz values greater than 800 kHz.

101. The capacitive responsive electronic switching circuit as defined in claim 94, wherein the supply voltage is a battery supply voltage.

102. The capacitive responsive electronic switching circuit as defined in claim 94, wherein the supply voltage is a voltage regulator supply voltage.

103. The capacitive responsive electronic switching circuit as defined in claim 94, wherein said detector circuit is configured to generate said control output signal only when the operator is proximal or touches said second touch terminal within a predetermined time period after the operator is proximal or touches said first touch terminal.

104. The capacitive responsive electronic switching circuit as defined in claim 94, further comprising an indicator for indicating the detector circuit has determined that the operator is proximal or touches said second touch terminal.

105. A capacitive responsive electronic switching circuit for a controlled keypad device comprising:

an oscillator providing a periodic output signal having a predefined frequency;

a microcontroller using the periodic output signal from the oscillator, the microcontroller selectively providing signal output frequencies to a closely spaced array of input touch terminals of a keypad, the input touch terminals comprising first and second input touch terminals, wherein the selectively providing comprises the microcontroller selectively providing a signal output frequency to each row of the closely spaced array of input touch terminals of the keypad;

the first and second input touch terminals defining areas for an operator to provide an input by proximity and touch; and

a detector circuit coupled to said oscillator for receiving said periodic output signal from said oscillator, and coupled to said first and second touch terminals, said

detector circuit being responsive to signals from said oscillator via said microcontroller and a presence of an operator's body capacitance to ground coupled to said first and second touch terminals when proximal or touched by the operator to provide a control output signal for actuation of the controlled keypad device, said detector circuit being configured to generate said control output signal when the operator is proximal or touches said second touch terminal after the operator is proximal or touches said first touch terminal.

106. The capacitive responsive electronic switching circuit as defined in claim 105, wherein each signal output frequency selectively provided to each row of the closely spaced array of input touch terminals of the keypad has a same Hertz value.

107. The capacitive responsive electronic switching circuit as defined in claim 105, wherein each signal output frequency selectively provided to each row of the closely spaced array of input touch terminals of the keypad is selected from a plurality of Hertz values.

108. The capacitive responsive electronic switching circuit as defined in claim 107, wherein the plurality of Hertz values comprises Hertz values greater than 50 kHz.

109. The capacitive responsive electronic switching circuit as defined in claim 107, wherein the plurality of Hertz values comprises Hertz values greater than 100 kHz.

110. The capacitive responsive electronic switching circuit as defined in claim 107, wherein the plurality of Hertz values comprises Hertz values greater than 800 kHz.

111. The capacitive responsive electronic switching circuit as defined in claim 105, wherein the detector circuit is configured to inhibit the control output signal unless the operator is proximal or touches said second touch terminal after the operator is proximal or touches said first touch terminal.

112. The capacitive responsive electronic switching circuit as defined in claim 105, wherein said first and second touch terminals are adapted to be mounted on different surfaces of the controlled keypad device.

113. The capacitive responsive electronic switching circuit as defined in claim 105, wherein said first and second touch terminals are adapted to be mounted on non-parallel planar surfaces of the controlled keypad device.

114. The capacitive responsive electronic switching circuit as defined in claim 105, wherein said first and second touch terminals are adapted to be mounted on perpendicular planar surfaces of the controlled keypad device.

115. The capacitive responsive electronic switching circuit as defined in claim 105 and further including an indicator for indicating when said detector circuit determines that the operator is proximal or touches said first touch terminal.

116. The capacitive responsive electronic switching circuit as defined in claim 105 and further including an indicator for indicating when said detector circuit determines that the operator is proximal or touches said second touch terminal.

117. The capacitive responsive electronic switching circuit as defined in claim 105, wherein the detector circuit comprises a plurality of touch circuits, and wherein the microcontroller selectively provides the signal output frequencies to the closely spaced array of input touch terminals of the keypad via the plurality of touch circuits.

* * * * *



UNITED STATES PATENT AND TRADEMARK OFFICE

UNITED STATES DEPARTMENT OF COMMERCE
United States Patent and Trademark Office
Address: COMMISSIONER FOR PATENTS
P.O. Box 1450
Alexandria, Virginia 22313-1450
www.uspto.gov

APPLICATION NO.	FILING DATE	FIRST NAMED INVENTOR	ATTORNEY DOCKET NO.	CONFIRMATION NO.
-----------------	-------------	----------------------	---------------------	------------------

90/013,106	12/24/2013	5796183	NAR-5796183RX2	9188
------------	------------	---------	----------------	------

25962 7590 06/11/2014
 SLATER & MATSIL, L.L.P.
 17950 PRESTON RD, SUITE 1000
 DALLAS, TX 75252-5793

EXAMINER

TRAN, HENRY N

ART UNIT	PAPER NUMBER
----------	--------------

3992

MAIL DATE	DELIVERY MODE
-----------	---------------

06/11/2014

PAPER

Please find below and/or attached an Office communication concerning this application or proceeding.

The time period for reply, if any, is set in the attached communication.

Notice of Intent to Issue Ex Parte Reexamination Certificate	Control No. 90/013,106	Patent Under Reexamination 5796183	
	Examiner HENRY N. TRAN	Art Unit 3992	AIA (First Inventor to File) Status No

-- The MAILING DATE of this communication appears on the cover sheet with the correspondence address --

1. Prosecution on the merits is (or remains) closed in this *ex parte* reexamination proceeding. This proceeding is subject to reopening at the initiative of the Office or upon petition. *Cf.* 37 CFR 1.313(a). A Certificate will be issued in view of
 - (a) Patent owner's communication(s) filed: 07 May 2014.
 - (b) Patent owner's failure to file an appropriate timely response to the Office action mailed: _____.
 - (c) Patent owner's failure to timely file an Appeal Brief (37 CFR 41.31).
 - (d) The decision on appeal by the Board of Patent Appeals and Interferences Court dated _____
 - (e) Other: _____.
2. The Reexamination Certificate will indicate the following:
 - (a) Change in the Specification: Yes No
 - (b) Change in the Drawing(s): Yes No
 - (c) Status of the Claim(s):
 - (1) Patent claim(s) confirmed: _____.
 - (2) Patent claim(s) amended (including dependent on amended claim(s)): _____
 - (3) Patent claim(s) canceled: 18,27 and 35.
 - (4) Newly presented claim(s) patentable: 40-117.
 - (5) Newly presented canceled claims: _____.
 - (6) Patent claim(s) previously currently disclaimed: _____
 - (7) Patent claim(s) not subject to reexamination: 1-17,19-26,28-34 and 36-39.
3. A declaration(s)/affidavit(s) under **37 CFR 1.130(b)** was/were filed on _____.
4. Note the attached statement of reasons for patentability and/or confirmation. Any comments considered necessary by patent owner regarding reasons for patentability and/or confirmation must be submitted promptly to avoid processing delays. Such submission(s) should be labeled: "Comments On Statement of Reasons for Patentability and/or Confirmation."
5. Note attached NOTICE OF REFERENCES CITED (PTO-892).
6. Note attached LIST OF REFERENCES CITED (PTO/SB/08 or PTO/SB/08 substitute).
7. The drawing correction request filed on _____ is: approved disapproved.
8. Acknowledgment is made of the priority claim under 35 U.S.C. § 119(a)-(d) or (f).
 - a) All b) Some* c) None of the certified copies have
 - been received.
 - not been received.
 - been filed in Application No. _____.
 - been filed in reexamination Control No. _____.
 - been received by the International Bureau in PCT Application No. _____.

* Certified copies not received: _____.
9. Note attached Examiner's Amendment.
10. Note attached Interview Summary (PTO-474).
11. Other: _____.

All correspondence relating to this reexamination proceeding should be directed to the **Central Reexamination Unit** at the mail, FAX, or hand-carry addresses given at the end of this Office action.

	/HENRY N TRAN/ Primary Examiner, Art Unit 3992
--	---

cc: Requester (if third party requester)

The present application is being examined under the pre-AIA first to invent provisions.

NOTICE OF INTENT TO ISSUE *EX PARTE* REEXAMINATION CERTIFICATE

INTRODUCTION

1. This Notice of Intent to Issue *Ex Parte* Reexamination Certificate (NIRC) action concerns the *Ex Parte* Reexamination Request (hereinafter “the Request”) filed by patent owner on December 24, 2013 for the *Ex Parte* Reexamination Certificate, the U.S. Patent No. 5,786,183 C1, issued on April 29, 2013 to Hourmand et al. (hereinafter “the ‘183 patent”); and it is responsive to the patent owner’s response filed on May 7, 2014 (hereinafter “the response”). The response has been entered. Claims 40-117 are subject to this reexamination; and they are found patentable and/or confirmed.

RESPONSE TO THE RESPONSE

2. Patent owner’s proposed amendment to the claims, see pages 2-14, filed with the response is in compliance with 37 CFR 1.530(d)-(j), and it has been entered. Claims 18, 27, and 35 are canceled; claims 40, 41, 56, 66, 67, 71, and 95 of the previously added new claims 40-105 are amended; and claims 106-117 are newly added. Claims 1-17, 19-26, 28-34, and 36-39 are not subject to reexamination. Thus, only claims 40-117 are subject to this reexamination.

3. Patent owner’s arguments, see pages 15-141, filed with the response, with respect to the claim rejections under 35 U.S.C. § 305, the prior art references of Boie, Gerpheide, Lee, and Casio, and the supports for new claims 40-117, have been fully considered and are persuasive. The

rejection of claims 18, 27, 40-44, 56-71, and 95-105 under 35 U.S.C. § 305 as recited in the prior Office action, see pages 9-11, mailed on March 27, 2014 has been overcome due to the amendment to the claims, and it has been withdrawn.

REFERENCES CITED IN THIS OFFICE ACTION

3. The prior art patents and printed publications (the prior art references) cited in the Request pursuant to C.F.R. § 1.510(b) (3), see the Request page 10, and relied upon are relisted below:

- U.S. Patent No. 5,463,388 issued to Boie et al. on October 31, 1995 ("Boie" or the '388 patent), which was submitted with the request as Exhibit C.
- U.S. Patent No. 5,565,658 issued to Gerpheide et al. on October 15, 1996 ("Gerpheide" or the '658 patent), which was submitted with the request as Exhibit D.
- Casio advertisement entitled "Now... The Invisible Casio Calculator Watch," published in Popular Science by On the Run in 1984 ("Casio"), which was submitted with the request as Exhibit E.
- Lee, thesis entitled "A Fast Multiple-Touch-Sensitive Input Device," and published October 1984 ("Lee"), which was submitted with the IDS filed with the request.

ALLOWABLE SUBJECT MATTER

4. New claims 40-117 are patentable.

STATEMENT OF REASONS FOR PATENTABILITY AND/OR CONFIRMATION

5. The following is an examiner's statement of reasons for patentability and/or confirmation of the claims found patentable in this reexamination proceeding:

Each of the newly added independent claims 45, 56, 72, 84, 95, 106, and 111 identifies the uniquely distinct features that are not taught or suggested by the cited prior art references, either alone or in any reasonable combinations. Specifically,

Regarding independent claim 45, claim 45 is similar to cancelled patent claim 18 but includes the new limitation of “*a microcontroller using the periodic output signal from the oscillator, the microcontroller selectively providing signal output frequencies directly to a plurality of small sized input touch terminals of a keypad;*”.

The combination of Boie, Gerpheide, Lee and/or Casio does not disclose or fairly suggest this limitation. The examiner agrees with the discussion articulated by the patent owner for claim 45; see the 12/24/2013 Amendment filed with the Request at pages 24-25.

Regarding independent claim 56, claim 56 is similar to cancelled patent claim 18 but includes the new limitation of “*a microcontroller using the periodic output signal from the oscillator, the microcontroller selectively providing signal output frequencies to a plurality of small sized input touch terminals of a keypad, wherein the selectively providing comprises the microcontroller selectively providing a signal output frequency to each row of the plurality of small sized input touch terminals of a keypad, and wherein a peak voltage of the signal output frequencies is greater than a supply voltage;*”.

The combination of Boie, Gerpheide, Lee and/or Casio does not disclose or fairly suggest this limitation. The examiner agrees with the discussions articulated by the patent owner for claim 56, see the 12/24/2013 Amendment filed with the Request at page 26 and the 5/7/14 Response at pages 16-17.

Regarding independent claim 72, claim 72 is similar to cancelled patent claim 27 but includes the new limitation of “*a microcontroller using the periodic output signal from the oscillator, the microcontroller selectively providing signal output frequencies directly to a closely spaced array of input touch terminals of a keypad, the input touch terminals comprising first and second input touch terminals;*” .

The combination of Boie, Gerpheide, Lee and/or Casio does not disclose or fairly suggest this limitation. The examiner agrees with the discussion articulated by the patent owner for claim 72, see the 5/7/14 Response at pages 27-28.

Regarding independent claim 84, claim 84 is similar to cancelled patent claim 27 but includes the new limitation of “*a microcontroller using the periodic output signal from the oscillator, the microcontroller selectively providing signal output frequencies to a closely spaced array of input touch terminals of a keypad, the input touch terminals comprising first and second input touch terminals, wherein a peak voltage of the signal output frequencies is greater than a supply voltage;*”.

The prior references, Boie, Gerpheide, Lee, and Casio, either alone or in any combination, do not disclose or fairly suggest this limitation. The examiner agrees with the discussions articulated by the patent owner for claim 84, see the 12/24/2013 Amendment filed with the Request at page 26 and the 5/7/14 Response at pages 28-29.

Regarding independent claim 95, claim 95 is similar to cancelled patent claim 27 but includes the new limitation of “*a microcontroller using the periodic output signal from the oscillator, the microcontroller selectively providing signal output frequencies to a closely spaced array of input touch terminals of a keypad, wherein the selectively providing comprises the microcontroller*

selectively providing a signal output frequency to each row of the closely spaced array of input touch terminals of a keypad, the input touch terminals comprising first and second input touch terminals, and wherein a peak voltage of the signal output frequencies is greater than a supply voltage;”.

The prior references, Boie, Gerpheide, Lee, and Casio, either alone or in any combination, do not disclose or fairly suggest this limitation. The examiner agrees with the discussion articulated by the patent owner for claim 95, see the 5/7/14 Response at pages 17-19.

Regarding independent claim 106, claim 106 is similar to cancelled patent claim 18 but includes the limitation of “*a microcontroller using the periodic output signal from the oscillator, the microcontroller selectively providing signal output frequencies to a plurality of small sized input touch terminals of a keypad, wherein the selectively providing comprises the microcontroller selectively providing a signal output frequency to each row of the plurality of small sized input touch terminals of a keypad.*”

The prior references, Boie, Gerpheide, Lee, and Casio, either alone or in any combination, do not disclose or fairly suggest this limitation. The examiner agrees with the discussion articulated by the patent owner for claim 106, see the 5/7/14 Response at pages 19-20.

Regarding independent claim 111, claim 111 is similar to cancelled patent claim 27 but includes the limitation of “*a microcontroller using the periodic output signal from the oscillator, the microcontroller selectively providing signal output frequencies to a closely spaced array of input touch terminals of a keypad, the input touch terminals comprising first and second input touch terminals, and wherein the selectively providing comprises the microcontroller selectively*

providing a signal output frequency to each row of closely spaced array of input touch terminals of a keypad.”

The prior references, Boie, Gerpheide, Lee, and Casio, either alone or in any combination, do not disclose or fairly suggest this limitation. The examiner agrees with the discussion articulated by the patent owner for claim 111, see the 5/7/14 Response at page 20.

Regarding dependent claims 46-55, claims 46-55 depend from claim 45 and add further limitations. They are allowable at least by the reason set forth for claim 45.

Regarding dependent claims 57-65, claims 57-65 depend from claim 56 and add further limitations. They are allowable at least by the reason set forth for claim 56.

Regarding dependent claims 73-83, claims 73-83 depend from claim 72 and add further limitations. They are allowable at least by the reason set forth for claim 72.

Regarding dependent claims 85-94, claims 85-94 depend from claim 84 and add further limitations. They are allowable at least by the reason set forth for claim 84.

Regarding dependent claims 96-104, claims 96-104 depend from claim 95 and add further limitations. They are allowable at least by the reason set forth for claim 95.

Regarding dependent claims 40-44 and 107-110, claims 40-44 and 107-110 depend from claim 106 and add further limitations. They are allowable at least by the reason set forth for claim 106.

Regarding dependent claims 66-71 and 112-117, claims 66-71 and 112-117 depend from claim 111 and add further limitations. They are allowable at least by the reason set forth for claim 111.

Any comments considered necessary by PATENT OWNER regarding the above statement must be submitted promptly to avoid processing delays. Such submission by the patent owner should

Art Unit: 3992

be labeled: "Comments on Statement of Reasons for Patentability and/or Confirmation" and will be placed in the reexamination file.

6. Claims 40-117 are renumbered consecutively in compliance with 37 CFR 1.126 and 37 CFR 1.530(g), see MPEP 608.01(j) and MPEP § 2250, as shown in the table below.

Claims renumbered in the same order as presented by applicant															
				CPA				T.D.				R.1.47			
Final	Original	Final	Original	Final	Original	Final	Original	Final	Original	Final	Original	Final	Original	Final	Original
1	1		18		56	60	62	109	59	66	68	103	103		
2	2	19	19	66	66	63	63	110	70	67	67	104	104		
3	3	20	20	37	37	64	64	111	71	68	68	95	105		
4	4	21	21	38	38	65	65	71	72	69	69	40	106		
5	5	22	22	39	39	61	66	73	73	90	90	46	107		
6	6	23	23	40	40	62	67	74	74	91	91	47	108		
7	7	24	24	41	41	63	68	75	75	92	92	48	109		
8	8	25	25	42	42	64	68	76	76	93	93	49	110		
9	9	26	26	43	43	67	60	77	77	94	94	105	111		
10	10		27	44	44	66	61	78	78	94	95	112	112		
11	11	28	28	50	45	65	62	79	79	96	96	113	113		
12	12	29	29	51	46	70	63	72	80	97	97	114	114		
13	13	30	30	52	47	64	64	80	81	98	98	115	115		
14	14	31	31	55	48	65	65	81	82	98	98	116	116		
15	15	32	32	57	49	106	66	82	83	100	100	117	117		
16	16	33	33	58	50	107	67	83	84	101	101				
17	17	34	34	59	51	108	68	84	85	102	102				

CONCLUSION

7. Extensions of Time

Extensions of time under 37 CFR 1.136(a) will not be permitted in these proceedings because the provisions of 37 CFR 1.136 apply only to "an applicant" and not to parties in a reexamination proceeding. Additionally, 35 U.S.C. 305 requires that reexamination proceedings "will be conducted with special dispatch" (37 CFR 1.550(a)). Extension of time in *ex parte* reexamination proceedings are provided for in 37 CFR 1.550(c).

8. Litigation Reminder

The patent owner is reminded of the continuing responsibility under 37 CFR 1.565(a) to apprise the Office of any litigation activity, or other prior or concurrent proceeding, involving the '183 patent throughout the course of this reexamination proceeding. See MPEP §§ 2207, 2282 and 2286.

9. Correspondence and Inquiry as to Office Actions

All correspondence related to this ex parte reexamination proceeding should be directed as follows:

By EFS: Registered users may submit via the electronic filing system EFS-Web, at <https://efs.uspto.gov/efile/myportal/efs-registered>

By Mail to: Mail Stop *Ex Parte* Reexam
Central Reexamination Unit
Commissioner for Patents
United States Patent & Trademark Office
P.O. Box 1450
Alexandria, VA 22313-1450

By FAX to: (571) 273-9900
Central Reexamination Unit

By hand: Customer Service Window
Randolph Building
401 Dulany Street
Alexandria, VA 2231

For EFS-Web transmissions, 37 CFR 1.8(a)(1)(i) (C) and (ii) states that correspondence (except for a request for reexamination and a corrected or replacement request for reexamination) will be considered timely filed if (a) it is transmitted via the Office's electronic filing system in

Application/Control Number: 90/013,106
Art Unit: 3992

Page 10

accordance with 37 CFR 1.6(a)(4), and (b) includes a certificate of transmission for each piece of correspondence stating the data of transmission, which is prior to the expiration of the set period of time in the Office action.

Any inquiry by the patent owner concerning this communication or earlier communications from the Legal Advisor or Examiner, or as to the status of this proceeding, should be directed to the Central Reexamination Unit at telephone number (571) 272-7705.

Signed:

/Henry N Tran/
Patent Reexamination Specialist,
CRU - Art Unit 3992

Conferees:

/Albert Gagliardi/
Patent Reexamination Specialist,
CRU - Art Unit 3992

/SUDHANSHU PATHAK/
Supervisory Patent Examiner, Art Unit 3992

Reexamination 	Application/Control No. 90013106	Applicant(s)/Patent Under Reexamination 5796183
	Certificate Date 04/29/2013	Certificate Number 5796183 C2

Requester Correspondence Address:	<input checked="" type="checkbox"/> Patent Owner	<input type="checkbox"/> Third Party
SLATER & MATSIL, L.L.P. 17950 PRESTON RD, SUITE 1000 DALLAS, TX 75252-5793		

LITIGATION REVIEW <input checked="" type="checkbox"/>	/HT/ (examiner initials)	01/26/2014 (date)
Case Name		Director Initials
1:06cv 1777 - CLOSED		
2:03cv75169 - CLOSED		
1:10cv691 - CLOSED		
2:06cv500 -CLOSED		

COPENDING OFFICE PROCEEDINGS	
TYPE OF PROCEEDING	NUMBER
1. NONE	

/HENRY N TRAN/ Primary Examiner.Art Unit 3992
--



UNITED STATES PATENT AND TRADEMARK OFFICE

UNITED STATES DEPARTMENT OF COMMERCE
 United States Patent and Trademark Office
 Address: COMMISSIONER FOR PATENTS
 P.O. Box 1450
 Alexandria, Virginia 22313-1450
 www.uspto.gov

BIB DATA SHEET

CONFIRMATION NO. 9188

SERIAL NUMBER 90/013,106	FILING or 371(c) DATE 12/24/2013 RULE	CLASS 307	GROUP ART UNIT 3992	ATTORNEY DOCKET NO. NAR-5796183RX2		
APPLICANTS						
INVENTORS 5796183, Residence Not Provided; NARTRON CORPORATION, REED CITY, MI;						
** CONTINUING DATA ***** This application is a REX of 08/601,268 01/31/1996 PAT 5796183						
** FOREIGN APPLICATIONS *****						
** IF REQUIRED, FOREIGN FILING LICENSE GRANTED ** ** SMALL ENTITY **						
Foreign Priority claimed <input type="checkbox"/> Yes <input checked="" type="checkbox"/> No	35 USC 119(a-d) conditions met <input type="checkbox"/> Yes <input checked="" type="checkbox"/> No	<input type="checkbox"/> Met after Allowance	STATE OR COUNTRY	SHEETS DRAWINGS	TOTAL CLAIMS	INDEPENDENT CLAIMS
Verified and Acknowledged	/HENRY N TRAN/ Examiner's Signature	Initials			32 114	8 14
ADDRESS SLATER & MATSIL, L.L.P. 17950 PRESTON RD, SUITE 1000 DALLAS, TX 75252-5793 UNITED STATES						
TITLE Capacitive Responsive Electronic Switching Circuit						
FILING FEE RECEIVED 6000	FEES: Authority has been given in Paper No. _____ to charge/credit DEPOSIT ACCOUNT No. _____ for following:		<input type="checkbox"/> All Fees <input type="checkbox"/> 1.16 Fees (Filing) <input type="checkbox"/> 1.17 Fees (Processing Ext. of time) <input type="checkbox"/> 1.18 Fees (Issue) <input type="checkbox"/> Other _____ <input type="checkbox"/> Credit			

Search Notes 	Application/Control No. 90013106	Applicant(s)/Patent Under Reexamination 5796183
	Examiner HENRY N TRAN	Art Unit 3992

CPC- SEARCHED		
Symbol	Date	Examiner

CPC COMBINATION SETS - SEARCHED		
Symbol	Date	Examiner

US CLASSIFICATION SEARCHED			
Class	Subclass	Date	Examiner
307	112,113,116,125,139,140,157	6/2/2014	HT
361	181	6/2/2014	HT

SEARCH NOTES		
Search Notes	Date	Examiner
Review of patented file's prosecution history	03/102014/	HT
Review of patented file's prosecution history	05/30 & 06/02/14	HT

INTERFERENCE SEARCH			
US Class/ CPC Symbol	US Subclass / CPC Group	Date	Examiner
307	112,113,116,125,139,140,157	6/2/14	HT
361	181	6/2/14	HT

	/HENRY N TRAN/ Primary Examiner.Art Unit 3992
--	--

Issue Classification 	Application/Control No. 90013106	Applicant(s)/Patent Under Reexamination 5796183
	Examiner HENRY N TRAN	Art Unit 3992

<input type="checkbox"/> Claims renumbered in the same order as presented by applicant																<input type="checkbox"/> CPA		<input type="checkbox"/> T.D.		<input type="checkbox"/> R.1.47	
Final	Original	Final	Original	Final	Original	Final	Original	Final	Original	Final	Original	Final	Original	Final	Original						
1	1		18		35	60	52	109	69	86	86	103	103								
2	2	19	19	36	36	53	53	110	70	87	87	104	104								
3	3	20	20	37	37	54	54	111	71	88	88	95	105								
4	4	21	21	38	38	55	55	71	72	89	89	40	106								
5	5	22	22	38	39	61	56	73	73	90	90	46	107								
6	6	23	23	45	40	62	57	74	74	91	91	47	108								
7	7	24	24	41	41	63	58	75	75	92	92	48	109								
8	8	25	25	42	42	66	59	76	76	93	93	49	110								
9	9	26	26	43	43	67	60	77	77	84	94	105	111								
10	10		27	44	44	68	61	78	78	94	95	112	112								
11	11	28	28	50	45	69	62	79	79	96	96	113	113								
12	12	29	29	51	46	70	63	72	80	97	97	114	114								
13	13	30	30	52	47	64	64	80	81	98	98	115	115								
14	14	31	31	56	48	65	65	81	82	99	99	116	116								
15	15	32	32	57	49	106	66	82	83	100	100	117	117								
16	16	33	33	58	50	107	67	83	84	101	101										
17	17	34	34	59	51	108	68	85	85	102	102										

NONE		Total Claims Allowed:	
		78	
(Assistant Examiner)	(Date)		
/HENRY N TRAN/ Primary Examiner. Art Unit 3992	06/03/2014	O.G. Print Claim(s)	O.G. Print Figure
(Primary Examiner)	(Date)	40	4

Index of Claims 	Application/Control No. 90013106	Applicant(s)/Patent Under Reexamination 5796183
	Examiner HENRY N TRAN	Art Unit 3992

✓	Rejected	-	Cancelled	N	Non-Elected	A	Appeal
=	Allowed	÷	Restricted	I	Interference	O	Objected

Claims renumbered in the same order as presented by applicant
 CPA
 T.D.
 R.1.47

CLAIM		DATE							
Final	Original	03/20/2014	06/03/2014						
1	1	N	N						
2	2	N	N						
3	3	N	N						
4	4	N	N						
5	5	N	N						
6	6	N	N						
7	7	N	N						
8	8	N	N						
9	9	N	N						
10	10	N	N						
11	11	N	N						
12	12	N	N						
13	13	N	N						
14	14	N	N						
15	15	N	N						
16	16	N	N						
17	17	N	N						
	18	✓	-						
19	19	N	N						
20	20	N	N						
21	21	N	N						
22	22	N	N						
23	23	N	N						
24	24	N	N						
25	25	N	N						
26	26	N	N						
	27	✓	-						
28	28	N	N						
29	29	N	N						
30	30	N	N						
31	31	N	N						
32	32	N	N						
33	33	N	N						
34	34	N	N						
	35	-	-						
36	36	N	N						

<i>Index of Claims</i> 	Application/Control No. 90013106	Applicant(s)/Patent Under Reexamination 5796183
	Examiner HENRY N TRAN	Art Unit 3992

✓	Rejected	-	Cancelled	N	Non-Elected	A	Appeal
=	Allowed	÷	Restricted	I	Interference	O	Objected

Claims renumbered in the same order as presented by applicant
 CPA
 T.D.
 R.1.47

CLAIM		DATE							
Final	Original	03/20/2014	06/03/2014						
37	37	N	N						
38	38	N	N						
39	39	N	N						
45	40	✓	=						
41	41	✓	=						
42	42	✓	=						
43	43	✓	=						
44	44	✓	=						
50	45	=	=						
51	46	=	=						
52	47	=	=						
56	48	=	=						
57	49	=	=						
58	50	=	=						
59	51	=	=						
60	52	=	=						
53	53	=	=						
54	54	=	=						
55	55	=	=						
61	56	✓	=						
62	57	✓	=						
63	58	✓	=						
66	59	✓	=						
67	60	✓	=						
68	61	✓	=						
69	62	✓	=						
70	63	✓	=						
64	64	✓	=						
65	65	✓	=						
106	66	✓	=						
107	67	✓	=						
108	68	✓	=						
109	69	✓	=						
110	70	✓	=						
111	71	✓	=						
71	72	=	=						

Index of Claims 	Application/Control No. 90013106	Applicant(s)/Patent Under Reexamination 5796183
	Examiner HENRY N TRAN	Art Unit 3992

✓	Rejected	-	Cancelled	N	Non-Elected	A	Appeal
=	Allowed	÷	Restricted	I	Interference	O	Objected

Claims renumbered in the same order as presented by applicant
 CPA
 T.D.
 R.1.47

CLAIM		DATE							
Final	Original	03/20/2014	06/03/2014						
73	73	=	=						
74	74	=	=						
75	75	=	=						
76	76	=	=						
77	77	=	=						
78	78	=	=						
79	79	=	=						
72	80	=	=						
80	81	=	=						
81	82	=	=						
82	83	=	=						
83	84	=	=						
85	85	=	=						
86	86	=	=						
87	87	=	=						
88	88	=	=						
89	89	=	=						
90	90	=	=						
91	91	=	=						
92	92	=	=						
93	93	=	=						
84	94	=	=						
94	95	✓	=						
96	96	✓	=						
97	97	✓	=						
98	98	✓	=						
99	99	✓	=						
100	100	✓	=						
101	101	✓	=						
102	102	✓	=						
103	103	✓	=						
104	104	✓	=						
95	105	✓	=						
40	106		=						
46	107		=						
47	108		=						

<i>Index of Claims</i> 	Application/Control No. 90013106	Applicant(s)/Patent Under Reexamination 5796183
	Examiner HENRY N TRAN	Art Unit 3992

✓	Rejected	-	Cancelled	N	Non-Elected	A	Appeal
=	Allowed	÷	Restricted	I	Interference	O	Objected

Claims renumbered in the same order as presented by applicant
 CPA
 T.D.
 R.1.47

CLAIM		DATE							
Final	Original	03/20/2014	06/03/2014						
48	109		=						
49	110		=						
105	111		=						
112	112		=						
113	113		=						
114	114		=						
115	115		=						
116	116		=						
117	117		=						

IN THE UNITED STATES PATENT AND TRADEMARK OFFICE

U.S. Patent No.: 5,796,183 B1 § Docket No.: 5796183RX2
Issued: August 18, 1998 § Inventors: Hourmand et al.
Filed: January 31, 1996 § Patent Owner: UUSI, LLC
Control No. TBD § Examiner: TBD
For: Capacitive Responsive Electronic Switching Circuit

Mail Stop *Ex Parte* Reexam
Attn: Central Reexamination Unit
Commissioner for Patents
P.O. Box 1450
Alexandria, VA 22313-1450

RESPONSE TO OFFICE ACTION

Dear Sir:

Patent Owner UUSI, LLC respectfully submits the following amendments and remarks in response to the Examiner's Office Action dated March 27, 2014. The Patent Owner respectfully requests the following amendments and remarks be entered and respectfully requests reconsideration of claims 40-117.

In the Claims:

18. (Canceled)

27. (Canceled)

35. (Canceled)

40. (New – Once Amended) The capacitive responsive electronic switching circuit as defined in claim 106, wherein each signal output frequency selectively provided to each row of the plurality of small sized input touch terminals of the keypad has a same Hertz value.

41. (New – Once Amended) The capacitive responsive electronic switching circuit as defined in claim 106, wherein each signal output frequency selectively provided to each row of the plurality of small sized input touch terminals of the keypad is selected from a plurality of Hertz values.

42. (New) The capacitive responsive electronic switching circuit as defined in claim 41, wherein the plurality of Hertz values comprises Hertz values greater than 50 kHz.

43. (New) The capacitive responsive electronic switching circuit as defined in claim 41, wherein the plurality of Hertz values comprises Hertz values greater than 100 kHz.

44. (New) The capacitive responsive electronic switching circuit as defined in claim 41, wherein the plurality of Hertz values comprises Hertz values greater than 800 kHz.

45. (New) A capacitive responsive electronic switching circuit comprising:
an oscillator providing a periodic output signal having a predefined frequency;
a microcontroller using the periodic output signal from the oscillator, the microcontroller selectively providing signal output frequencies directly to a plurality of small sized input touch terminals of a keypad;
the plurality of small sized input touch terminals defining adjacent areas on a dielectric

substrate for an operator to provide inputs by proximity and touch; and

a detector circuit coupled to said oscillator for receiving said periodic output signal from said oscillator, and coupled to said input touch terminals, said detector circuit being responsive to signals from said oscillator via said microcontroller and a presence of an operator's body capacitance to ground coupled to said touch terminals when proximal or touched by the operator to provide a control output signal,

wherein said predefined frequency of said oscillator and said signal output frequencies are selected to decrease a first impedance of said dielectric substrate relative to a second impedance of any contaminate that may create an electrical path on said dielectric substrate between said adjacent areas defined by the plurality of small sized input touch terminals, and wherein said detector circuit compares a sensed body capacitance change to ground proximate an input touch terminal to a threshold level to prevent inadvertent generation of the control output signal.

46. (New) The capacitive responsive electronic switching circuit as defined in claim 45, wherein the sensed body capacitance change to ground proximate the input touch terminal is caused by the operator's body capacitance decreasing an input touch terminal signal on the detector circuit, and wherein the sensed body capacitance change to ground is compared to a second threshold level to generate the control output signal.

47. (New) The capacitive responsive electronic switching circuit as defined in claim 45, wherein the sensed body capacitance change to ground proximate the input touch terminal is caused by the operator's body capacitance decreasing an input touch terminal signal amplitude on the detector circuit, and wherein the sensed body capacitance change to ground is compared to a second threshold level to generate the control output signal.

48. (New) The capacitive responsive electronic switching circuit as defined in claim 45, wherein the signal output frequencies have a same Hertz value.

49. (New) The capacitive responsive electronic switching circuit as defined in claim 45, wherein each signal output frequency is selected from a plurality of Hertz values.

50. (New) The capacitive responsive electronic switching circuit as defined in claim 49, wherein the plurality of Hertz values comprises Hertz values greater than 50 kHz.

51. (New) The capacitive responsive electronic switching circuit as defined in claim 49, wherein the plurality of Hertz values comprises Hertz values greater than 100 kHz.

52. (New) The capacitive responsive electronic switching circuit as defined in claim 49, wherein the plurality of Hertz values comprises Hertz values greater than 800 kHz.

53. (New) The capacitive responsive electronic switching circuit as defined in claim 45, wherein a peak voltage of the signal output frequencies is greater than a supply voltage.

54. (New) The capacitive responsive electronic switching circuit as defined in claim 53, wherein the supply voltage is a battery supply voltage.

55. (New) The capacitive responsive electronic switching circuit as defined in claim 53, wherein the supply voltage is a voltage regulator supply voltage.

56. (New – Once Amended) A capacitive responsive electronic switching circuit comprising:

an oscillator providing a periodic output signal having a predefined frequency;

a microcontroller using the periodic output signal from the oscillator, the microcontroller selectively providing signal output frequencies to a plurality of small sized input touch terminals of a keypad, wherein the selectively providing comprises the microcontroller selectively providing a signal output frequency to each row of the plurality of small sized input touch terminals of the keypad, and wherein a peak voltage of the signal output frequencies is greater than a supply voltage;

the plurality of small sized input touch terminals defining adjacent areas on a dielectric substrate for an operator to provide inputs by proximity and touch; and

a detector circuit coupled to said oscillator for receiving said periodic output signal from said oscillator, and coupled to said input touch terminals, said detector circuit being responsive to signals from said oscillator via said microcontroller and a presence of an operator's body

capacitance to ground coupled to said touch terminals when proximal or touched by the operator to provide a control output signal.

wherein said predefined frequency of said oscillator and said signal output frequencies are selected to decrease a first impedance of said dielectric substrate relative to a second impedance of any contaminate that may create an electrical path on said dielectric substrate between said adjacent areas defined by the plurality of small sized input touch terminals, and wherein said detector circuit compares a sensed body capacitance change to ground proximate an input touch terminal to a threshold level to prevent inadvertent generation of the control output signal.

57. (New) The capacitive responsive electronic switching circuit as defined in claim 56, wherein the sensed body capacitance change to ground proximate the input touch terminal is caused by the operator's body capacitance decreasing an input touch terminal signal on the detector circuit, and wherein the sensed body capacitance change to ground is compared to a second threshold level to generate the control output signal.

58. (New) The capacitive responsive electronic switching circuit as defined in claim 56, wherein the sensed body capacitance change to ground proximate the input touch terminal is caused by the operator's body capacitance decreasing an input touch terminal signal amplitude on the detector circuit, and wherein the sensed body capacitance change to ground is compared to a second threshold level to generate the control output signal.

59. (New) The capacitive responsive electronic switching circuit as defined in claim 56, wherein each signal output frequency selectively provided to each row of the plurality of small sized input touch terminals of the keypad has a same Hertz value.

60. (New) The capacitive responsive electronic switching circuit as defined in claim 56, wherein each signal output frequency selectively provided to each row of the plurality of small sized input touch terminals of the keypad is selected from a plurality of Hertz values.

61. (New) The capacitive responsive electronic switching circuit as defined in claim 60, wherein the plurality of Hertz values comprises Hertz values greater than 50 kHz.

62. (New) The capacitive responsive electronic switching circuit as defined in claim 60, wherein the plurality of Hertz values comprises Hertz values greater than 100 kHz.

63. (New) The capacitive responsive electronic switching circuit as defined in claim 60, wherein the plurality of Hertz values comprises Hertz values greater than 800 kHz.

64. (New) The capacitive responsive electronic switching circuit as defined in claim 56, wherein the supply voltage is a battery supply voltage.

65. (New) The capacitive responsive electronic switching circuit as defined in claim 56, wherein the supply voltage is a voltage regulator supply voltage.

66. (New – Once Amended) The capacitive responsive electronic switching circuit as defined in claim 111, wherein each signal output frequency selectively provided to each row of the closely spaced array of input touch terminals of the keypad has a same Hertz value.

67. (New – Once Amended) The capacitive responsive electronic switching circuit as defined in claim 111, wherein each signal output frequency selectively provided to each row of the closely spaced array of input touch terminals of the keypad is selected from a plurality of Hertz values.

68. (New) The capacitive responsive electronic switching circuit as defined in claim 67, wherein the plurality of Hertz values comprises Hertz values greater than 50 kHz.

69. (New) The capacitive responsive electronic switching circuit as defined in claim 67, wherein the plurality of Hertz values comprises Hertz values greater than 100 kHz.

70. (New) The capacitive responsive electronic switching circuit as defined in claim 67, wherein the plurality of Hertz values comprises Hertz values greater than 800 kHz.

71. (New – Once Amended) The capacitive responsive electronic switching circuit as defined in claim 111, wherein the detector circuit is configured to inhibit the control output

signal unless the operator is proximal or touches said second touch terminal after the operator is proximal or touches said first touch terminal.

72. (New) A capacitive responsive electronic switching circuit for a controlled keypad device comprising:

an oscillator providing a periodic output signal having a predefined frequency;

a microcontroller using the periodic output signal from the oscillator, the microcontroller selectively providing signal output frequencies directly to a closely spaced array of input touch terminals of a keypad, the input touch terminals comprising first and second input touch terminals;

the first and second input touch terminals defining areas for an operator to provide an input by proximity and touch; and

a detector circuit coupled to said oscillator for receiving said periodic output signal from said oscillator, and coupled to said first and second touch terminals, said detector circuit being responsive to signals from said oscillator via said microcontroller and a presence of an operator's body capacitance to ground coupled to said first and second touch terminals when proximal or touched by the operator to provide a control output signal for actuation of the controlled keypad device, said detector circuit being configured to generate said control output signal when the operator is proximal or touches said second touch terminal after the operator is proximal or touches said first touch terminal.

73. (New) The capacitive responsive electronic switching circuit as defined in claim 72, wherein the signal output frequencies have a same Hertz value.

74. (New) The capacitive responsive electronic switching circuit as defined in claim 72, wherein each signal output frequency is selected from a plurality of Hertz values.

75. (New) The capacitive responsive electronic switching circuit as defined in claim 74, wherein the plurality of Hertz values comprises Hertz values greater than 50 kHz.

76. (New) The capacitive responsive electronic switching circuit as defined in claim 74, wherein the plurality of Hertz values comprises Hertz values greater than 100 kHz.

77. (New) The capacitive responsive electronic switching circuit as defined in claim 74, wherein the plurality of Hertz values comprises Hertz values greater than 800 kHz.

78. (New) The capacitive responsive electronic switching circuit as defined in claim 72, wherein said detector circuit is configured to generate said control output signal only when the operator is proximal or touches said second touch terminal within a predetermined time period after the operator is proximal or touches said first touch terminal.

79. (New) The capacitive responsive electronic switching circuit as defined in claim 72, further comprising an indicator for indicating the detector circuit has determined that the operator is proximal or touches said second touch terminal.

80. (New) The capacitive responsive electronic switching circuit as defined in claim 72, wherein the detector circuit is configured to inhibit the control output signal unless the operator is proximal or touches said second touch terminal after the operator is proximal or touches said first touch terminal.

81. (New) The capacitive responsive electronic switching circuit as defined in claim 72, wherein a peak voltage of the signal output frequencies is greater than a supply voltage.

82. (New) The capacitive responsive electronic switching circuit as defined in claim 81, wherein the supply voltage is a battery supply voltage.

83. (New) The capacitive responsive electronic switching circuit as defined in claim 81, wherein the supply voltage is a voltage regulator supply voltage.

84. (New) A capacitive responsive electronic switching circuit for a controlled keypad device comprising:

an oscillator providing a periodic output signal having a predefined frequency;
a microcontroller using the periodic output signal from the oscillator, the microcontroller selectively providing signal output frequencies to a closely spaced array of input touch terminals of a keypad, the input touch terminals comprising first and second input touch terminals, wherein

a peak voltage of the signal output frequencies is greater than a supply voltage;

the first and second input touch terminals defining areas for an operator to provide an input by proximity and touch; and

a detector circuit coupled to said oscillator for receiving said periodic output signal from said oscillator, and coupled to said first and second touch terminals, said detector circuit being responsive to signals from said oscillator via said microcontroller and a presence of an operator's body capacitance to ground coupled to said first and second touch terminals when proximal or touched by the operator to provide a control output signal for actuation of the controlled keypad device, said detector circuit being configured to generate said control output signal when the operator is proximal or touches said second touch terminal after the operator is proximal or touches said first touch terminal.

85. (New) The capacitive responsive electronic switching circuit as defined in claim 84, wherein the signal output frequencies have a same Hertz value.

86. (New) The capacitive responsive electronic switching circuit as defined in claim 84, wherein each signal output frequency is selected from a plurality of Hertz values.

87. (New) The capacitive responsive electronic switching circuit as defined in claim 86, wherein the plurality of Hertz values comprises Hertz values greater than 50 kHz.

88. (New) The capacitive responsive electronic switching circuit as defined in claim 86, wherein the plurality of Hertz values comprises Hertz values greater than 100 kHz.

89. (New) The capacitive responsive electronic switching circuit as defined in claim 86, wherein the plurality of Hertz values comprises Hertz values greater than 800 kHz.

90. (New) The capacitive responsive electronic switching circuit as defined in claim 84, wherein the supply voltage is a battery supply voltage.

91. (New) The capacitive responsive electronic switching circuit as defined in claim 84, wherein the supply voltage is a voltage regulator supply voltage.

92. (New) The capacitive responsive electronic switching circuit as defined in claim 84, wherein said detector circuit is configured to generate said control output signal only when the operator is proximal or touches said second touch terminal within a predetermined time period after the operator is proximal or touches said first touch terminal.

93. (New) The capacitive responsive electronic switching circuit as defined in claim 84, further comprising an indicator for indicating the detector circuit has determined that the operator is proximal or touches said second touch terminal.

94. (New) The capacitive responsive electronic switching circuit as defined in claim 84, wherein the detector circuit is configured to inhibit the control output signal unless the operator is proximal or touches said second touch terminal after the operator is proximal or touches said first touch terminal.

95. (New – Once Amended) A capacitive responsive electronic switching circuit for a controlled keypad device comprising:

an oscillator providing a periodic output signal having a predefined frequency;

a microcontroller using the periodic output signal from the oscillator, the microcontroller selectively providing signal output frequencies to a closely spaced array of input touch terminals of a keypad, wherein the selectively providing comprises the microcontroller selectively providing a signal output frequency to each row of the closely spaced array of input touch terminals of the keypad, the input touch terminals comprising first and second input touch terminals, and wherein a peak voltage of the signal output frequencies is greater than a supply voltage;

the first and second input touch terminals defining areas for an operator to provide an input by proximity and touch; and

a detector circuit coupled to said oscillator for receiving said periodic output signal from said oscillator, and coupled to said first and second touch terminals, said detector circuit being responsive to signals from said oscillator via said microcontroller and a presence of an operator's body capacitance to ground coupled to said first and second touch terminals when proximal or touched by the operator to provide a control output signal for actuation of the controlled keypad

device, said detector circuit being configured to generate said control output signal when the operator is proximal or touches said second touch terminal after the operator is proximal or touches said first touch terminal.

96. (New) The capacitive responsive electronic switching circuit as defined in claim 95, wherein each signal output frequency selectively provided to each row of the closely spaced array of input touch terminals of the keypad has a same Hertz value.

97. (New) The capacitive responsive electronic switching circuit as defined in claim 95, wherein each signal output frequency selectively provided to each row of the closely spaced array of input touch terminals of the keypad is selected from a plurality of Hertz values.

98. (New) The capacitive responsive electronic switching circuit as defined in claim 97, wherein the plurality of Hertz values comprises Hertz values greater than 50 kHz.

99. (New) The capacitive responsive electronic switching circuit as defined in claim 97, wherein the plurality of Hertz values comprises Hertz values greater than 100 kHz.

100. (New) The capacitive responsive electronic switching circuit as defined in claim 97, wherein the plurality of Hertz values comprises Hertz values greater than 800 kHz.

101. (New) The capacitive responsive electronic switching circuit as defined in claim 95, wherein the supply voltage is a battery supply voltage.

102. (New) The capacitive responsive electronic switching circuit as defined in claim 95, wherein the supply voltage is a voltage regulator supply voltage.

103. (New) The capacitive responsive electronic switching circuit as defined in claim 95, wherein said detector circuit is configured to generate said control output signal only when the operator is proximal or touches said second touch terminal within a predetermined time period after the operator is proximal or touches said first touch terminal.

104. (New) The capacitive responsive electronic switching circuit as defined in claim 95, further comprising an indicator for indicating the detector circuit has determined that the operator is proximal or touches said second touch terminal.

105. (New) The capacitive responsive electronic switching circuit as defined in claim 95, wherein the detector circuit is configured to inhibit the control output signal unless the operator is proximal or touches said second touch terminal after the operator is proximal or touches said first touch terminal.

106. (New) A capacitive responsive electronic switching circuit comprising:
an oscillator providing a periodic output signal having a predefined frequency;
a microcontroller using the periodic output signal from the oscillator, the microcontroller selectively providing signal output frequencies to a plurality of small sized input touch terminals of a keypad, wherein the selectively providing comprises the microcontroller selectively providing a signal output frequency to each row of the plurality of small sized input touch terminals of the keypad;

the plurality of small sized input touch terminals defining adjacent areas on a dielectric substrate for an operator to provide inputs by proximity and touch; and

a detector circuit coupled to said oscillator for receiving said periodic output signal from said oscillator, and coupled to said input touch terminals, said detector circuit being responsive to signals from said oscillator via said microcontroller and a presence of an operator's body capacitance to ground coupled to said touch terminals when proximal or touched by the operator to provide a control output signal.

wherein said predefined frequency of said oscillator and said signal output frequencies are selected to decrease a first impedance of said dielectric substrate relative to a second impedance of any contaminate that may create an electrical path on said dielectric substrate between said adjacent areas defined by the plurality of small sized input touch terminals, and wherein said detector circuit compares a sensed body capacitance change to ground proximate an input touch terminal to a threshold level to prevent inadvertent generation of the control output signal.

107. (New) The capacitive responsive switching circuit as defined in claim 106, wherein said oscillator provides a periodic output signal having a frequency of 800 kHz or greater.

108. (New) The capacitive responsive electronic switching circuit as defined in claim 106, wherein the sensed body capacitance change to ground proximate the input touch terminal is caused by the operator's body capacitance decreasing an input touch terminal signal on the detector circuit, and wherein the sensed body capacitance change to ground is compared to a second threshold level to generate the control output signal.

109. (New) The capacitive responsive electronic switching circuit as defined in claim 106, wherein the sensed body capacitance change to ground proximate the input touch terminal is caused by the operator's body capacitance decreasing an input touch terminal signal amplitude on the detector circuit, and wherein the sensed body capacitance change to ground is compared to a second threshold level to generate the control output signal.

110. (New) The capacitive responsive electronic switching circuit as defined in claim 106, wherein the detector circuit comprises a plurality of touch circuits, and wherein the microcontroller selectively provides the signal output frequencies to the plurality of small sized input touch terminals of the keypad via the plurality of touch circuits.

111. (New) A capacitive responsive electronic switching circuit for a controlled keypad device comprising:

an oscillator providing a periodic output signal having a predefined frequency;

a microcontroller using the periodic output signal from the oscillator, the microcontroller selectively providing signal output frequencies to a closely spaced array of input touch terminals of a keypad, the input touch terminals comprising first and second input touch terminals, wherein the selectively providing comprises the microcontroller selectively providing a signal output frequency to each row of the closely spaced array of input touch terminals of the keypad;

the first and second input touch terminals defining areas for an operator to provide an input by proximity and touch; and

a detector circuit coupled to said oscillator for receiving said periodic output signal from said oscillator, and coupled to said first and second touch terminals, said detector circuit being

responsive to signals from said oscillator via said microcontroller and a presence of an operator's body capacitance to ground coupled to said first and second touch terminals when proximal or touched by the operator to provide a control output signal for actuation of the controlled keypad device, said detector circuit being configured to generate said control output signal when the operator is proximal or touches said second touch terminal after the operator is proximal or touches said first touch terminal.

112. (New) The capacitive responsive electronic switching circuit as defined in claim 111, wherein said first and second touch terminals are adapted to be mounted on different surfaces of the controlled keypad device.

113. (New) The capacitive responsive electronic switching circuit as defined in claim 111, wherein said first and second touch terminals are adapted to be mounted on non-parallel planar surfaces of the controlled keypad device.

114. (New) The capacitive responsive electronic switching circuit as defined in claim 111, wherein said first and second touch terminals are adapted to be mounted on perpendicular planar surfaces of the controlled keypad device.

115. (New) The capacitive responsive electronic switching circuit as defined in claim 111 and further including an indicator for indicating when said detector circuit determines that the operator is proximal or touches said first touch terminal.

116. (New) The capacitive responsive electronic switching circuit as defined in claim 111 and further including an indicator for indicating when said detector circuit determines that the operator is proximal or touches said second touch terminal.

117. (New) The capacitive responsive electronic switching circuit as defined in claim 111, wherein the detector circuit comprises a plurality of touch circuits, and wherein the microcontroller selectively provides the signal output frequencies to the closely spaced array of input touch terminals of the keypad via the plurality of touch circuits.

REMARKS

Claims 1-17, 19-26, 28-34, and 36-39 are unamended with respect to the first Ex Parte Reexamination Certificate No. 5,796,183 C1 issued April 29, 2013. Claims 18, 27, and 35 are canceled herein. Claims 40-105 were previously added, and claims 106-117 are newly added by this amendment. The present amendment neither enlarges the scope of the claims of the patent nor introduces new matter.

Allowance of Claims

The Patent Owner acknowledges allowance of claims 45-55 and 72-94.

Claim Rejections under 35 U.S.C. § 305

Claims 18, 27, 40-44, 56-71, and 95-105 were rejected under 35 U.S.C. § 305 as enlarging the scope of claims 18 and 27 of the patent being reexamined. The Patent Owner respectfully submits that the amendments made herein overcome these rejections. In particular, the amendments to each independent claim restore the amended clause to its original form, and add the new claim language as a separate clause, so that the original clause retains its original scope. The Patent Owner further provides below a discussion of the newly-amended claims with respect to the cited prior art references.

Independent Claim 18

Independent claim 18 has been canceled and rewritten as new claim 106 per the Examiner's suggestion in Section 5 of the Office Action. Dependent claims 40-44 now depend from new claim 106. Likewise, dependent claims 107-109 – corresponding to claims 19, 33, and 34 – have been added and depend from claim 106. Each of these claims is allowable at least for the reasons discussed below with respect to claim 106.

Independent Claim 27

Independent claim 27 has been canceled and rewritten as new claim 111 per the Examiner's suggestion in Section 5 of the Office Action. Dependent claims 66-71 now depend from new claim 111. Likewise, dependent claims 112-117 – corresponding to claims 28-32 and 36 – have been added and depend from claim 111. Each of these claims is allowable at least for the reasons discussed below with respect to claim 111.

Independent Claim 56

Claim 56 has been amended to restore the previously amended clause to its original form and to add the new claim language as a separate clause, so that the original clause retains its original scope. More specifically, independent claim 56 recites “a microcontroller using the periodic output signal from the oscillator, the microcontroller selectively providing signal output frequencies to a plurality of small sized input touch terminals of a keypad, wherein the selectively providing comprises the microcontroller selectively providing a signal output frequency to each row of the plurality of small sized input touch terminals of the keypad, and wherein a peak voltage of the signal output frequencies is greater than a supply voltage.” None of the cited references, alone or in combination, teaches or suggests these limitations.

Rather, Boie discloses that “RF oscillator 408 provides an RF signal, for example, 100 kilohertz, to circuits 401, synchronous detector and filter 404 via inverter 410, and guard plane 411.” Boie, col. 3:67-col. 4:2. Boie further discloses that “[t]he effects of electrode-to-electrode capacitances, wiring capacitances and other extraneous capacitances are minimized by driving all electrodes and guard plane 411 in unison with the same RF signal from RF oscillator 408.” *Id.* at col. 4:58-60; *see id.* at Fig. 4. Thus, Boie discloses driving the electrodes of electrode array 100 and guard plane 411 with a single RF signal. As acknowledged by the Examiner, “Boie does not teach or suggest the microcontroller is used to selectively provid[e] signal output frequencies to input touch terminals of a keypad.” Office Action, p. 15. Therefore, Boie does not teach or suggest a microcontroller providing signal output frequencies to these components, wherein the microcontroller selectively provides a signal output frequency to each row of the plurality of small sized input touch terminals of the keypad.

Neither Gerpheide nor Lee cures the deficiencies of Boie. While Gerpheide teaches a reference frequency generator 16 “observes position signals to evaluate the extent of interference at some reference frequency” and that in “the event that substantial interference is detected, the generator 16 selects a different frequency for further measurements,” Gerpheide does not teach that a microcontroller provides these frequencies selectively to each row of the input touch terminals. *See, e.g., id.* at col. 8:22-30; Fig. 7. Rather, in Gerpheide, the “reference frequency signal is supplied to unit 14 via an AND gate 72.... The AND gate output feeds through inverter 74 and noninverting buffer 76 to wires RP and RN respectively which are part of a capacitive measurement element 78.” *See id.* at col. 6:19-26; Fig. 4. Thus, the output of AND gate 72 is

sent to every row of electrode array 12 via one of inverter 74 and noninverting buffer 76 at the same time. Therefore, Gerpheide does not disclose a microcontroller selectively providing a signal output frequency to each row of a plurality of small sized input touch terminals of a keypad.

Likewise, Lee does not teach or suggest that a microcontroller selectively provides a signal output frequency to each row of a plurality of small sized input touch terminals of a keypad. The Examiner has also acknowledged Lee does not disclose this limitation. *See, e.g.*, Office Action, p. 16 (“Lee does not teach or suggest sending signal output frequencies to the selected rows.”). Rather, Lee teaches the CPU selects or deselects row(s) by sending binary signals to the selected row(s). *See, e.g., id.* at Figs. 3.1(a), 3.1(b), and 3.4. Therefore, Lee does not teach or suggest a microcontroller selectively providing a signal output frequency to each row of a plurality of small sized input touch terminals of a keypad.

Moreover, none of the cited references teaches or suggests wherein a peak voltage of the signal output frequencies is greater than a supply voltage.

Accordingly, Boie in combination with Gerpheide and/or Lee does not disclose all of the elements of claim 56, and therefore claim 56 is patentable over these references.

New claims 57-65 depend from claim 56 and add further limitations. The Patent Owner respectfully submits that these dependent claims are allowable by reason of depending from an allowable claim as well as for adding new limitations.

Independent Claim 95

Claim 95 has been amended to restore the previously amended clause to its original form and to add the new claim language as a separate clause, so that the original clause retains its original scope. More specifically, independent claim 95 recites “a microcontroller using the periodic output signal from the oscillator, the microcontroller selectively providing signal output frequencies to a closely spaced array of input touch terminals of a keypad, wherein the selectively providing comprises the microcontroller selectively providing a signal output frequency to each row of the closely spaced array of input touch terminals of the keypad, the input touch terminals comprising first and second input touch terminals, and wherein a peak voltage of the signal output frequencies is greater than a supply voltage.” None of the cited references, alone or in combination, teaches or suggests these limitations.

Rather, Boie discloses that “RF oscillator 408 provides an RF signal, for example, 100 kilohertz, to circuits 401, synchronous detector and filter 404 via inverter 410, and guard plane 411.” Boie, col. 3:67-col. 4:2. Boie further discloses that “[t]he effects of electrode-to-electrode capacitances, wiring capacitances and other extraneous capacitances are minimized by driving all electrodes and guard plane 411 in unison with the same RF signal from RF oscillator 408.” *Id.* at col. 4:58-60; *see id.* at Fig. 4. Thus Boie discloses driving the electrodes of electrode array 100 and guard plane 411 with a single RF signal. As acknowledged by the Examiner, “Boie does not teach or suggest the microcontroller is used to selectively provid[e] signal output frequencies to input touch terminals of a keypad.” Office Action, p. 15. Therefore, Boie does not teach or suggest the microcontroller selectively providing signal output frequencies to a closely spaced array of input touch terminals of a keypad, wherein the selectively providing comprises the microcontroller selectively providing a signal output frequency to each row of the closely spaced array of input touch terminals of the keypad, the input touch terminals comprising first and second input touch terminals.

None of Gerpheide, Lee or Casio cures the deficiencies of Boie. While Gerpheide teaches a reference frequency generator 16 “observes position signals to evaluate the extent of interference at some reference frequency” and that in “the event that substantial interference is detected, the generator 16 selects a different frequency for further measurements,” Gerpheide does not teach that a microcontroller provides these frequencies selectively to each row of the input touch terminals. *See, e.g., id.* at col. 8:22-30; Fig. 7. Rather, in Gerpheide, the “reference frequency signal is supplied to unit 14 via an AND gate 72.... The AND gate output feeds through inverter 74 and noninverting buffer 76 to wires RP and RN respectively which are part of a capacitive measurement element 78.” *See id.* at col. 6:19-26; Fig. 4. Thus, the output of AND gate 72 is sent to every row of electrode array 12 via one of inverter 74 and noninverting buffer 76 at the same time. Therefore, Gerpheide does not disclose a signal output frequency is selectively provided to each row of a plurality of small sized input touch terminals of a keypad.

Likewise, Lee does not teach or suggest that a microcontroller selectively provides a signal output frequency to each row of a plurality of small sized input touch terminals of a keypad. The Examiner has also acknowledged Lee does not disclose this limitation. *See, e.g.,* Office Action, p. 16 (“Lee does not teach or suggest sending signal output frequencies to the selected rows.”). Rather, Lee teaches the CPU selects or deselects row(s) by sending binary

signals to the selected row(s). *See, e.g., id.* at Figs. 3.1(a), 3.1(b), and 3.4. In contrast, claim 95 recites selectively providing a signal output frequency to each row of the touch terminals. Therefore, Lee does not teach or suggest a microcontroller selectively providing a signal output frequency to each row of the closely spaced array of input touch terminals of the keypad.

Casio discloses input touch terminals comprising first and second input touch terminals, *see, e.g.,* Figure, but fails to provide any teaching with respect to the microcontroller selectively providing signal output frequencies to a closely spaced array of input touch terminals of a keypad, wherein the selectively providing comprises the microcontroller selectively providing a signal output frequency to each row of the closely spaced array of input touch terminals of the keypad.

Moreover, none of the cited references teaches or suggests wherein a peak voltage of the signal output frequencies is greater than a supply voltage.

Accordingly, Boie in combination with Gerpheide, Lee and/or Casio does not disclose all of the elements of claim 95, and therefore claim 95 is patentable over these references.

New claims 96-105 depend from claim 95 and add further limitations. The Patent Owner respectfully submits that these dependent claims are allowable by reason of depending from an allowable claim as well as for adding new limitations.

Independent Claim 106

As discussed above, independent claim 18 has been canceled and rewritten as new claim 106 per the Examiner's suggestion in Section 5 of the Office Action. Claim 106 also restores the previously amended clause of claim 18 to its original form and adds the new claim language as a separate clause, so that the original clause retains its original scope. More specifically, independent claim 106 recites "a microcontroller using the periodic output signal from the oscillator, the microcontroller selectively providing signal output frequencies to a plurality of small sized input touch terminals of a keypad, wherein the selectively providing comprises the microcontroller selectively providing a signal output frequency to each row of the plurality of small sized input touch terminals of the keypad." None of the cited references, alone or in combination, teaches or suggests these limitations.

As discussed above with respect to claim 56, the cited references, either alone or in combination, fail to teach or suggest the microcontroller selectively providing signal output frequencies to a plurality of small sized input touch terminals of a keypad, wherein the

selectively providing comprises the microcontroller selectively providing a signal output frequency to each row of the plurality of small sized input touch terminals of the keypad. For at least these same reasons, claim 106 is allowable over the cited art.

New claims 40-44 and 107-110 depend from claim 106 and add further limitations. The Patent Owner respectfully submits that these dependent claims are allowable by reason of depending from an allowable claim as well as for adding new limitations.

Independent Claim 111

As discussed above, independent claim 27 has been canceled and rewritten as new claim 111 per the Examiner's suggestion in Section 5 of the Office Action. Claim 111 also restores the previously amended clause of claim 27 to its original form and adds the new claim language as a separate clause, so that the original clause retains its original scope. More specifically, independent claim 111 recites "a microcontroller using the periodic output signal from the oscillator, the microcontroller selectively providing signal output frequencies to a closely spaced array of input touch terminals of a keypad, the input touch terminals comprising first and second input touch terminals, wherein the selectively providing comprises the microcontroller selectively providing a signal output frequency to each row of the closely spaced array of input touch terminals of the keypad." None of the cited references, alone or in combination, teaches or suggests these limitations.

As discussed above with respect to claim 95, the cited references, either alone or in combination, fail to teach or suggest the microcontroller selectively providing signal output frequencies to a closely spaced array of input touch terminals of a keypad, the input touch terminals comprising first and second input touch terminals, wherein the selectively providing comprises the microcontroller selectively providing a signal output frequency to each row of the closely spaced array of input touch terminals of the keypad.

Accordingly, Boie in combination with Gerpheide, Lee and/or Casio does not disclose all of the elements of claim 111, and therefore claim 111 is patentable over these references.

New claims 66-71 and 112-117 depend from claim 111 and add further limitations. The Patent Owner respectfully submits that these dependent claims are allowable by reason of depending from an allowable claim as well as for adding new limitations.

Support for New Claims

Support for each of the new claims 40-117 may be found throughout the `183 Patent, and particular support may be found, for example, as set forth in the charts below. These charts follow the same organizational structure as those provided in the Amendment Accompanying Request for Ex Parte Reexamination under 35 U.S.C. §§ 302-307 filed on December 24, 2013

A. Canceled Claim 18

Claim 18 has been canceled herein, thus no chart of claim support is provided.

B. Canceled Claim 27

Claim 27 has been canceled herein, thus no chart of claim support is provided.

C. New Claim 40

`183 Patent Claim Language	`183 Patent Support
<p>40. The capacitive responsive electronic switching circuit as defined in claim 106, wherein each signal output frequency selectively provided to each row of the plurality of small sized input touch terminals of the keypad has a same Hertz value.</p>	<p>See Figure 11.</p> <p>The `183 Patent discloses “The touch detection circuit of the present invention features operation at frequencies at or above 50 kHz and preferably at or above 800 kHz to minimize the effects of surface contamination from materials such a [sic] skin oils and water. Col. 5:49-53.</p> <p>The `183 Patent discloses “Conversely, at 100 kHz, the glass impedance drops to approximately 1 MΩ resulting in the impedance of the path to ground for pad 59 being twice that of the touched pad 57. For cases where background noise and temperature drifts are comparatively small, a 100 kHz oscillator frequency would allow a sufficiently low detection threshold to be set to differentiate between the signal changes induced at both pads by a human touch opposite a single pad. At 800 kHz, the impedance of the glass drops to 200 kΩ or lower giving a ratio of a greater than 5 to 1 impedance difference between the paths to ground of the touched pad 57 and adjacent pads 59. In fact, the impedance ratio may exceed 10 to 1, as illustrated in the calculation below. This</p>

`183 Patent Claim Language	`183 Patent Support
	<p>allows the detection threshold for the touched pad to be set well below that of an adjacent pad resulting in a much lower incidence of inadvertent actuation of adjacent touch pads to that of the touched pad. Ideally, the frequency of operation would be kept at the 800 kHz of the preferred embodiment or even higher. However, as noted earlier, higher frequency operation forces the use of more expensive components and designs. For applications where thermal drift and electronic noise levels are low, operation at or near 100 kHz may be possible. However, at 10 kHz and below, the impedance of the glass becomes much greater than that of likely water bridges between pads resulting in adjacent pads being effected as much by a touch as the touched pad itself. Although the preferred frequency is at or above 100 kHz, and more preferably at or above 800 kHz, it is conceivable that frequencies as low as 50 kHz could be used provided the frequency creates a difference in the impedance paths of adjacent pads that is sufficient enough to accurately distinguish between an intended touch and the touch of an adjacent pad. Use of frequencies as low as 50 kHz may also be possible depending upon the type of glass or covering or the thickness thereof used for the touch pad. Col. 10:60 – Col. 11:27.</p> <p>The `183 Patent discloses “As will be apparent to those skilled in the art, the values of the resistors and capacitors utilized in oscillator 200 may be varied from those disclosed above to provide for different oscillator output frequencies. As discussed above, however, oscillator 200 is preferably constructed so as to output a square wave having a frequency of 50 kHz or greater, and more preferably, of 800 kHz or greater. Col. 14:22-28.</p> <p>The `183 Patent disclosed “The combination of oscillator voltage, frequency and transistor gain bandwidth product that is used will necessarily vary with the cost, safety and reliability</p>

`183 Patent Claim Language	`183 Patent Support
	requirements of a given application.” Col. 14:65 – Col. 15:1.

D. New Claim 41

`183 Patent Claim Language	`183 Patent Support
<p>41. The capacitive responsive electronic switching circuit as defined in claim 106, wherein each signal output frequency selectively provided to each row of the plurality of small sized input touch terminals of the keypad is selected from a plurality of Hertz values.</p>	<p>See Figure 11.</p> <p>The `183 Patent discloses “The touch detection circuit of the present invention features operation at frequencies at or above 50 kHz and preferably at or above 800 kHz to minimize the effects of surface contamination from materials such a [sic] skin oils and water. Col. 5:49-53.</p> <p>The `183 Patent discloses “Conversely, at 100 kHz, the glass impedance drops to approximately 1 MΩ resulting in the impedance of the path to ground for pad 59 being twice that of the touched pad 57. For cases where background noise and temperature drifts are comparatively small, a 100 kHz oscillator frequency would allow a sufficiently low detection threshold to be set to differentiate between the signal changes induced at both pads by a human touch opposite a single pad. At 800 kHz, the impedance of the glass drops to 200 kΩ or lower giving a ratio of a greater than 5 to 1 impedance difference between the paths to ground of the touched pad 57 and adjacent pads 59. In fact, the impedance ratio may exceed 10 to 1, as illustrated in the calculation below. This allows the detection threshold for the touched pad to be set well below that of an adjacent pad resulting in a much lower incidence of inadvertent actuation of adjacent touch pads to that of the touched pad. Ideally, the frequency of operation would be kept at the 800 kHz of the preferred embodiment or even higher. However, as noted earlier, higher frequency operation forces the use of more expensive components and designs. For applications where thermal drift and electronic noise levels are low, operation at or near 100 kHz may be possible. However, at</p>

`183 Patent Claim Language	`183 Patent Support
	<p>10 kHz and below, the impedance of the glass becomes much greater than that of likely water bridges between pads resulting in adjacent pads being effected as much by a touch as the touched pad itself. Although the preferred frequency is at or above 100 kHz, and more preferably at or above 800 kHz, it is conceivable that frequencies as low as 50 kHz could be used provided the frequency creates a difference in the impedance paths of adjacent pads that is sufficient enough to accurately distinguish between an intended touch and the touch of an adjacent pad. Use of frequencies as low as 50 kHz may also be possible depending upon the type of glass or covering or the thickness thereof used for the touch pad. Col. 10:60 – Col. 11:27.</p> <p>The `183 Patent discloses “As will be apparent to those skilled in the art, the values of the resistors and capacitors utilized in oscillator 200 may be varied from those disclosed above to provide for different oscillator output frequencies. As discussed above, however, oscillator 200 is preferably constructed so as to output a square wave having a frequency of 50 kHz or greater, and more preferably, of 800 kHz or greater. Col. 14:22-28.</p> <p>The `183 Patent disclosed “The combination of oscillator voltage, frequency and transistor gain bandwidth product that is used will necessarily vary with the cost, safety and reliability requirements of a given application.” Col. 14:65 – Col. 15:1.</p>

E. New Claim 42

`183 Patent Claim Language	`183 Patent Support
<p>42. The capacitive responsive electronic switching circuit as defined in claim 41, wherein the plurality of Hertz values comprises Hertz values greater</p>	<p>See Figure 11.</p> <p>The `183 Patent discloses “The touch detection circuit of the present invention features operation at frequencies at or above 50 kHz and preferably at or above 800 kHz to minimize the effects of</p>

`183 Patent Claim Language	`183 Patent Support
<p>than 50 kHz.</p>	<p>surface contamination from materials such a [sic] skin oils and water. Col. 5:49-53.</p> <p>The `183 Patent discloses “Conversely, at 100 kHz, the glass impedance drops to approximately 1 MΩ resulting in the impedance of the path to ground for pad 59 being twice that of the touched pad 57. For cases where background noise and temperature drifts are comparatively small, a 100 kHz oscillator frequency would allow a sufficiently low detection threshold to be set to differentiate between the signal changes induced at both pads by a human touch opposite a single pad. At 800 kHz, the impedance of the glass drops to 200 kΩ or lower giving a ratio of a greater than 5 to 1 impedance difference between the paths to ground of the touched pad 57 and adjacent pads 59. In fact, the impedance ratio may exceed 10 to 1, as illustrated in the calculation below. This allows the detection threshold for the touched pad to be set well below that of an adjacent pad resulting in a much lower incidence of inadvertent actuation of adjacent touch pads to that of the touched pad. Ideally, the frequency of operation would be kept at the 800 kHz of the preferred embodiment or even higher. However, as noted earlier, higher frequency operation forces the use of more expensive components and designs. For applications where thermal drift and electronic noise levels are low, operation at or near 100 kHz may be possible. However, at 10 kHz and below, the impedance of the glass becomes much greater than that of likely water bridges between pads resulting in adjacent pads being effected as much by a touch as the touched pad itself. Although the preferred frequency is at or above 100 kHz, and more preferably at or above 800 kHz, it is conceivable that frequencies as low as 50 kHz could be used provided the frequency creates a difference in the impedance paths of adjacent pads that is sufficient enough to accurately distinguish between an intended touch and the touch of an adjacent pad. Use of</p>

`183 Patent Claim Language	`183 Patent Support
	<p>frequencies as low as 50 kHz may also be possible depending upon the type of glass or covering or the thickness thereof used for the touch pad. Col. 10:60 – Col. 11:27.</p> <p>The `183 Patent discloses “As will be apparent to those skilled in the art, the values of the resistors and capacitors utilized in oscillator 200 may be varied from those disclosed above to provide for different oscillator output frequencies. As discussed above, however, oscillator 200 is preferably constructed so as to output a square wave having a frequency of 50 kHz or greater, and more preferably, of 800 kHz or greater. Col. 14:22-28.</p> <p>The `183 Patent disclosed “The combination of oscillator voltage, frequency and transistor gain bandwidth product that is used will necessarily vary with the cost, safety and reliability requirements of a given application.” Col. 14:65 – Col. 15:1.</p>

F. New Claim 43

`183 Patent Claim Language	`183 Patent Support
<p>43. The capacitive responsive electronic switching circuit as defined in claim 41, wherein the plurality of Hertz values comprises Hertz values greater than 100 kHz.</p>	<p>See Figure 11.</p> <p>The `183 Patent discloses “The touch detection circuit of the present invention features operation at frequencies at or above 50 kHz and preferably at or above 800 kHz to minimize the effects of surface contamination from materials such a [sic] skin oils and water. Col. 5:49-53.</p> <p>The `183 Patent discloses “Conversely, at 100 kHz, the glass impedance drops to approximately 1 MΩ resulting in the impedance of the path to ground for pad 59 being twice that of the touched pad 57. For cases where background noise and temperature drifts are comparatively small, a 100 kHz oscillator frequency would allow a sufficiently low detection threshold to be set to differentiate</p>

`183 Patent Claim Language	`183 Patent Support
	<p>between the signal changes induced at both pads by a human touch opposite a single pad. At 800 kHz, the impedance of the glass drops to 200 kΩ or lower giving a ratio of a greater than 5 to 1 impedance difference between the paths to ground of the touched pad 57 and adjacent pads 59. In fact, the impedance ratio may exceed 10 to 1, as illustrated in the calculation below. This allows the detection threshold for the touched pad to be set well below that of an adjacent pad resulting in a much lower incidence of inadvertent actuation of adjacent touch pads to that of the touched pad. Ideally, the frequency of operation would be kept at the 800 kHz of the preferred embodiment or even higher. However, as noted earlier, higher frequency operation forces the use of more expensive components and designs. For applications where thermal drift and electronic noise levels are low, operation at or near 100 kHz may be possible. However, at 10 kHz and below, the impedance of the glass becomes much greater than that of likely water bridges between pads resulting in adjacent pads being effected as much by a touch as the touched pad itself. Although the preferred frequency is at or above 100 kHz, and more preferably at or above 800 kHz, it is conceivable that frequencies as low as 50 kHz could be used provided the frequency creates a difference in the impedance paths of adjacent pads that is sufficient enough to accurately distinguish between an intended touch and the touch of an adjacent pad. Use of frequencies as low as 50 kHz may also be possible depending upon the type of glass or covering or the thickness thereof used for the touch pad. Col. 10:60 – Col. 11:27.</p> <p>The `183 Patent discloses “As will be apparent to those skilled in the art, the values of the resistors and capacitors utilized in oscillator 200 may be varied from those disclosed above to provide for different oscillator output frequencies. As discussed above, however, oscillator 200 is preferably constructed so as to</p>

`183 Patent Claim Language	`183 Patent Support
	<p>output a square wave having a frequency of 50 kHz or greater, and more preferably, of 800 kHz or greater. Col. 14:22-28.</p> <p>The `183 Patent disclosed “The combination of oscillator voltage, frequency and transistor gain bandwidth product that is used will necessarily vary with the cost, safety and reliability requirements of a given application.” Col. 14:65 – Col. 15:1.</p>

G. New Claim 44

`183 Patent Claim Language	`183 Patent Support
<p>44. The capacitive responsive electronic switching circuit as defined in claim 41, wherein the plurality of Hertz values comprises Hertz values greater than 800 kHz.</p>	<p>See Fig. 11.</p> <p>The `183 Patent discloses “The touch detection circuit of the present invention features operation at frequencies at or above 50 kHz and preferably at or above 800 kHz to minimize the effects of surface contamination from materials such a [sic] skin oils and water. Col. 5:49-53.</p> <p>The `183 Patent discloses “At 800 kHz, the impedance of the glass drops to 200 kΩ or lower giving a ratio of a greater than 5 to 1 impedance difference between the paths to ground of the touched pad 57 and adjacent pads 59. In fact, the impedance ratio may exceed 10 to 1, as illustrated in the calculation below. This allows the detection threshold for the touched pad to be set well below that of an adjacent pad resulting in a much lower incidence of inadvertent actuation of adjacent touch pads to that of the touched pad. Ideally, the frequency of operation would be kept at the 800 kHz of the preferred embodiment or even higher. However, as noted earlier, higher frequency operation forces the use of more expensive components and designs. For applications where thermal drift and electronic noise levels are low, operation at or near 100 kHz may be possible. However, at 10 kHz and below, the impedance of the glass becomes much greater than that of likely water bridges</p>

`183 Patent Claim Language	`183 Patent Support
	<p>between pads resulting in adjacent pads being effected as much by a touch as the touched pad itself. Although the preferred frequency is at or above 100 kHz, and more preferably at or above 800 kHz, it is conceivable that frequencies as low as 50 kHz could be used provided the frequency creates a difference in the impedance paths of adjacent pads that is sufficient enough to accurately distinguish between an intended touch and the touch of an adjacent pad. Use of frequencies as low as 50 kHz may also be possible depending upon the type of glass or covering or the thickness thereof used for the touch pad. Col. 11:1-27.</p> <p>The `183 Patent discloses “As will be apparent to those skilled in the art, the values of the resistors and capacitors utilized in oscillator 200 may be varied from those disclosed above to provide for different oscillator output frequencies. As discussed above, however, oscillator 200 is preferably constructed so as to output a square wave having a frequency of 50 kHz or greater, and more preferably, of 800 kHz or greater. Col. 14:22-28.</p> <p>The `183 Patent disclosed “The combination of oscillator voltage, frequency and transistor gain bandwidth product that is used will necessarily vary with the cost, safety and reliability requirements of a given application.” Col. 14:65 – Col. 15:1.</p>

H. New Claim 45

For ease of analysis, new independent claim 45 is shown below with pseudo-amendments illustrating the differences between new claim 45 and claim 18 of the `183 Patent following the first reexamination proceeding.

`183 Patent Claim Language	`183 Patent Support
45. A capacitive responsive electronic switching circuit comprising:	See Claim 18.

`183 Patent Claim Language	`183 Patent Support
<p>an oscillator providing a periodic output signal having a predefined frequency;</p>	<p>See Claim 18.</p>
<p>a microcontroller using the periodic output signal from the oscillator, the microcontroller selectively providing signal output frequencies <u>directly</u> to a plurality of small sized input touch terminals of a keypad;</p>	<p>See Figures 4, 11; and Claims 8, 12, 16.</p> <p>The `183 Patent discloses “The touch detection circuit of the present invention features operation at frequencies at or above 50kHz and preferably at or above 800 kHz to minimize the effects of surface contamination from materials such a [sic] skin oils and water. It also offers improvements in detection sensitivity that allow close control of the degree of proximity (ideally very close proximity) that is required for actuation and to enable employment of a multiplicity of small sized touch terminals in a physically close array such as a keyboard.” Col. 5:49-57.</p> <p>The `183 Patent discloses “In a first preferred embodiment the circuit offers enhanced detection sensitivity to allow reliable operation with small (finger size) touch pads.” Col. 6:1-3.</p> <p>The `183 Patent discloses “Although the preferred frequency is at or above 100 kHz, and more preferably at or above 800 kHz, it is conceivable that frequencies as low as 50 kHz could be used provided the frequency creates a difference in the impedance paths of adjacent pads that is sufficient enough to accurately distinguish between an intended touch and the touch of an adjacent pad. Use of frequencies as low as 50 kHz may also be possible depending upon the type of glass or covering or the thickness thereof used for the touch pad.” Col. 11:19-27.</p> <p>The `183 Patent discloses “Upon being powered by voltage regulator 100, oscillator 200 generates a square wave with a frequency of 50 kHz, and preferably greater than 800 kHz, and having an amplitude of 26 V peak. The square wave generated by oscillator 200 is supplied via</p>

`183 Patent Claim Language	`183 Patent Support
	<p>line 201 to a floating common generator 300, a touch pad shield plate 460, a touch circuit 400, and a microcontroller 500. Oscillator 200 is described below with reference to FIG. 6. Floating common generator 300 receives the 26 V peak square wave from oscillator 200 and outputs a regulated floating common that is 5 volts below the square wave output from oscillator 200 and has the same phase and frequency as the received square wave. This floating common output is supplied to touch circuit 400 and microcontroller 500 via line 301 such that the output square wave from oscillator 200 and floating common output from floating common generator 300 provide power to touch circuit 400 and microcontroller 500. Details of floating common generator 300 are discussed below with reference to FIG. 7.</p> <p>Touch circuit 400 senses capacitance from a touch pad 450 via line 451 and outputs a signal to microcontroller 500 via line 401 upon detecting a capacitance to ground at touch pad 450 that exceeds a threshold value. The details of touch circuit 400 are described below with reference to FIG. 8.</p> <p>Upon receiving an indication from touch circuit 400 that a sufficient capacitance to ground (typically at least 20 pF) is present at touch pad 450, microcontroller 500 outputs a signal to a load-controlling microcontroller 600 via line 501, which is preferably a two way optical coupling bus.” Col. 12:6-33.</p> <p>The `183 Patent discloses “As will be apparent to those skilled in the art, the values of the resistors and capacitors utilized in oscillator 200 may be varied from those disclosed above to provide for different oscillator output frequencies.” Col. 14:22-25.</p> <p>The `183 Patent discloses “A multiple touch pad circuit constructed in accordance with the second embodiment is shown in FIG. 11. In the second embodiment of FIG. 11, components</p>

`183 Patent Claim Language	`183 Patent Support
	<p>similar to those in the first embodiment in FIG. 4 are designated with the same references numerals and will not be discussed in detail. The multiple touch pad circuit is a variation of the first embodiment in that it includes an array of touch circuits designated as 900₁ through 900_{nm}, which, as shown, include both the touch circuit 400 shown in FIGS. 4 and 8 and the input touch terminal pad 451 (FIG. 4). Microcontroller 500 selects each row of the touch circuits 900₁ to 900_{nm} by providing the signal from oscillator 200 to selected rows of touch circuits. In this manner, microcontroller 500 can sequentially activate the touch circuit rows and associate the received inputs from the columns of the array with the activated touch circuit(s). To keep the path length 451 between the touch pad 450 and the base to the detection transistor 410 to a minimum, the detection circuits 900 are physically located directly beneath the touch pads. To simplify assembly, a flexible circuit board such as vended by Sheldahl, Inc. or Circuit Etching Technics, Inc. can be used for this purpose. Ideally, the printed circuit will be fixed directly against the surface (typically glass) bearing the conductive touch pads to eliminate air gaps and the need for conductive foam pads and spring contacts which were used to fill air gaps.” Col. 18:34-59.</p>
<p>the plurality of small sized input touch terminals defining adjacent areas on a dielectric substrate for an operator to provide inputs by proximity and touch; and</p>	<p>See Claim 18.</p>
<p>a detector circuit coupled to said oscillator for receiving said periodic output signal from said oscillator, and coupled to said input touch terminals, said detector circuit being responsive to signals from said oscillator via said microcontroller and a presence of an operator's body capacitance to ground coupled to said touch terminals when</p>	<p>See Claim 18.</p>

`183 Patent Claim Language	`183 Patent Support
proximal or touched by the operator to provide a control output signal,	
wherein said predefined frequency of said oscillator and said signal output frequencies are selected to decrease a first impedance of said dielectric substrate relative to a second impedance of any contaminate that may create an electrical path on said dielectric substrate between said adjacent areas defined by the plurality of small sized input touch terminals, and wherein said detector circuit compares a sensed body capacitance change to ground proximate an input touch terminal to a threshold level to prevent inadvertent generation of the control output signal.	See Claim 18.

I. New Claim 46

For ease of analysis, new dependent claim 46 is shown below with pseudo-amendments illustrating the differences between new claim 46 and claim 33 of the `183 Patent following the first reexamination proceeding.

`183 Patent Claim Language	`183 Patent Support
46. The capacitive responsive electronic switching circuit as defined in claim 45, further comprising wherein said detector circuit compares the sensed body capacitance change <u>to ground proximate the input touch terminal</u> is caused by the <u>operator's</u> body capacitance decreasing an input touch terminal signal on the detector circuit, and wherein the sensed body <u>capacitance change</u> to ground when proximate to the input touch terminal is compared to a second threshold level to generate the control output signal.	See Claims 1, 18, 28, and 33. The `183 Patent discloses “The touch detection circuit of the present invention features operation at frequencies at or above 50 kHz and preferably at or above 800 kHz to minimize the effects of surface contamination from materials such a [sic] skin oils and water. It also offers improvements in detection sensitivity that allow close control of the degree of proximity (ideally very close proximity) that is required for actuation and to enable employment of a multiplicity of small sized touch terminals in a physically close array such as a keyboard.” Col. 5:49-57. The `183 Patent discloses “Touch circuit 400 senses capacitance from a touch pad 450 via line

`183 Patent Claim Language	`183 Patent Support
	<p>451 and outputs a signal to microcontroller 500 via line 401 upon detecting a capacitance to ground at touch pad 450 that exceeds a threshold value. The details of touch circuit 400 are described below with reference to FIG. 8.” Col. 12:24-28.</p> <p>The `183 Patent discloses “As can be seen, at 1 kHz, the capacitive impedance of the glass is much greater than the nominal 1 MΩ of the water bridge across the pads. As a result, at 1 kHz, there would be little difference in the impedance paths to ground of the two adjacent pads when either is touched. This would result in the voltage on both pads being pulled towards ground by comparable amounts. Conversely, at 100 kHz, the glass impedance drops to approximately 1 MΩ resulting in the impedance of the path to ground for pad 59 being twice that of the touched pad 57. For cases where background noise and temperature drifts are comparatively small, a 100 kHz oscillator frequency would allow a sufficiently low detection threshold to be set to differentiate between the signal changes induced at both pads by a human touch opposite a single pad. At 800 kHz, the impedance of the glass drops to 200 kΩ or lower giving a ratio of a greater than 5 to 1 impedance difference between the paths to ground of the touched pad 57 and adjacent pads 59. In fact, the impedance ratio may exceed 10 to 1, as illustrated in the calculation below. This allows the detection threshold for the touched pad to be set well below that of an adjacent pad resulting in a much lower incidence of inadvertent actuation of adjacent touch pads to that of the touched pad. Col. 10:54 – Col. 11:9.</p> <p>The `183 Patent discloses “As stated above, the operator’s body includes a capacitance to ground, which may range in a typical person from between 20 to 300 pF. The base terminal of transistor 410 is coupled to it’s [sic] emitter by resistor 412 such that unless capacitance is</p>

`183 Patent Claim Language	`183 Patent Support
	<p>present by the user touching the touch pad 450, transistor 410 will not be forward biased and will not conduct. Thus, when touch pad 450 is not touched, the output signal at the collector terminal of transistor 410 and across pulse stretcher circuit 417 will be zero volts. When, however, a person touches the touch pad 450, that person's body capacitance to ground couples the base of transistor 410 to ground 103 through resistor 413, thereby forward biasing transistor 410 into conduction. This charges capacitor 418 providing a positive DC voltage with respect to the line 301 and causes the output of the Schmitt trigger 420 to go low. Diode 414 is coupled across the base to emitter junction of transistor 410 to clamp the base emitter reverse bias voltage to -0.7V and also reduce the forward recovery and turn-on time. Col. 15:29-47.</p>

J. New Claim 47

For ease of analysis, new dependent claim 47 is shown below with pseudo-amendments illustrating the differences between new claim 47 and claim 34 of the `183 Patent following the first reexamination proceeding.

`183 Patent Claim Language	`183 Patent Support
<p>47. The capacitive responsive electronic switching circuit as defined in claim 45, further comprising wherein said detector circuit compares the sensed body capacitance change to <u>ground proximate the input touch terminal</u> is caused by the <u>operator's</u> body capacitance decreasing an input touch terminal signal amplitude on the detector <u>circuit, and wherein the sensed body capacitance change to ground when proximate to the input touch terminal is compared</u> to a second threshold level to generate the control output signal.</p>	<p>See Claims 1, 18, 28, and 34.</p> <p>The `183 Patent discloses "Another method for implementing capacitive touch switches relies on the change in capacitive coupling between a touch terminal and ground. Systems utilizing such a method are described in U.S. Pat. No. 4,758,735 and U.S. Pat. No. 5,087,825. With this methodology the detection circuit consists of an oscillator (or AC line voltage derivative) providing a signal to a touch terminal whose voltage is then monitored by a detector. The touch terminal is driven in electrical series with other components that function in part as a charge pump. The touch of an operator then provides a capacitive short to ground via the operator's own body capacitance that lowers the</p>

`183 Patent Claim Language	`183 Patent Support
	<p>amplitude of oscillator voltage seen at the touch terminal.” Col. 3:44-56.</p> <p>The `183 Patent discloses “The touch detection circuit of the present invention features operation at frequencies at or above 50 kHz and preferably at or above 800 kHz to minimize the effects of surface contamination from materials such a [sic] skin oils and water. It also offers improvements in detection sensitivity that allow close control of the degree of proximity (ideally very close proximity) that is required for actuation and to enable employment of a multiplicity of small sized touch terminals in a physically close array such as a keyboard.” Col. 5:49-57.</p> <p>The `183 Patent discloses “Touch circuit 400 senses capacitance from a touch pad 450 via line 451 and outputs a signal to microcontroller 500 via line 401 upon detecting a capacitance to ground at touch pad 450 that exceeds a threshold value. The details of touch circuit 400 are described below with reference to FIG. 8.” Col. 12:24-28.</p> <p>The `183 Patent discloses “As can be seen, at 1 kHz, the capacitive impedance of the glass is much greater than the nominal 1 MΩ of the water bridge across the pads. As a result, at 1 kHz, there would be little difference in the impedance paths to ground of the two adjacent pads when either is touched. This would result in the voltage on both pads being pulled towards ground by comparable amounts. Conversely, at 100 kHz, the glass impedance drops to approximately 1 MΩ resulting in the impedance of the path to ground for pad 59 being twice that of the touched pad 57. For cases where background noise and temperature drifts are comparatively small, a 100 kHz oscillator frequency would allow a sufficiently low detection threshold to be set to differentiate between the signal changes induced at both pads</p>

`183 Patent Claim Language	`183 Patent Support
	<p>by a human touch opposite a single pad. At 800 kHz, the impedance of the glass drops to 200 kΩ or lower giving a ratio of a greater than 5 to 1 impedance difference between the paths to ground of the touched pad 57 and adjacent pads 59. In fact, the impedance ratio may exceed 10 to 1, as illustrated in the calculation below. This allows the detection threshold for the touched pad to be set well below that of an adjacent pad resulting in a much lower incidence of inadvertent actuation of adjacent touch pads to that of the touched pad. Col. 10:54 – Col. 11:9.</p> <p>The `183 Patent discloses “As stated above, the operator’s body includes a capacitance to ground, which may range in a typical person from between 20 to 300 pF. The base terminal of transistor 410 is coupled to it’s [sic] emitter by resistor 412 such that unless capacitance is present by the user touching the touch pad 450, transistor 410 will not be forward biased and will not conduct. Thus, when touch pad 450 is not touched, the output signal at the collector terminal of transistor 410 and across pulse stretcher circuit 417 will be zero volts. When, however, a person touches the touch pad 450, that person’s body capacitance to ground couples the base of transistor 410 to ground 103 through resistor 413, thereby forward biasing transistor 410 into conduction. This charges capacitor 418 providing a positive DC voltage with respect to the line 301 and causes the output of the Schmitt trigger 420 to go low. Diode 414 is coupled across the base to emitter junction of transistor 410 to clamp the base emitter reverse bias voltage to –0.7V and also reduce the forward recovery and turn-on time. Col. 15:29-47.</p>

K. New Claim 48

`183 Patent Claim Language	`183 Patent Support
48. The capacitive responsive electronic switching circuit as defined in claim 45, wherein the signal output	See Figure 11. The `183 Patent discloses “The touch detection

`183 Patent Claim Language	`183 Patent Support
<p>frequencies have a same Hertz value.</p>	<p>circuit of the present invention features operation at frequencies at or above 50 kHz and preferably at or above 800 kHz to minimize the effects of surface contamination from materials such a [sic] skin oils and water. Col. 5:49-53.</p> <p>The `183 Patent discloses “Conversely, at 100 kHz, the glass impedance drops to approximately 1 MΩ resulting in the impedance of the path to ground for pad 59 being twice that of the touched pad 57. For cases where background noise and temperature drifts are comparatively small, a 100 kHz oscillator frequency would allow a sufficiently low detection threshold to be set to differentiate between the signal changes induced at both pads by a human touch opposite a single pad. At 800 kHz, the impedance of the glass drops to 200 kΩ or lower giving a ratio of a greater than 5 to 1 impedance difference between the paths to ground of the touched pad 57 and adjacent pads 59. In fact, the impedance ratio may exceed 10 to 1, as illustrated in the calculation below. This allows the detection threshold for the touched pad to be set well below that of an adjacent pad resulting in a much lower incidence of inadvertent actuation of adjacent touch pads to that of the touched pad. Ideally, the frequency of operation would be kept at the 800 kHz of the preferred embodiment or even higher. However, as noted earlier, higher frequency operation forces the use of more expensive components and designs. For applications where thermal drift and electronic noise levels are low, operation at or near 100 kHz may be possible. However, at 10 kHz and below, the impedance of the glass becomes much greater than that of likely water bridges between pads resulting in adjacent pads being effected as much by a touch as the touched pad itself. Although the preferred frequency is at or above 100 kHz, and more preferably at or above 800 kHz, it is conceivable that frequencies as low as 50 kHz could be used provided the frequency creates a difference in the impedance</p>

`183 Patent Claim Language	`183 Patent Support
	<p>paths of adjacent pads that is sufficient enough to accurately distinguish between an intended touch and the touch of an adjacent pad. Use of frequencies as low as 50 kHz may also be possible depending upon the type of glass or covering or the thickness thereof used for the touch pad. Col. 10:60 – Col. 11:27.</p> <p>The `183 Patent discloses “As will be apparent to those skilled in the art, the values of the resistors and capacitors utilized in oscillator 200 may be varied from those disclosed above to provide for different oscillator output frequencies. As discussed above, however, oscillator 200 is preferably constructed so as to output a square wave having a frequency of 50 kHz or greater, and more preferably, of 800 kHz or greater. Col. 14:22-28.</p> <p>The `183 Patent disclosed “The combination of oscillator voltage, frequency and transistor gain bandwidth product that is used will necessarily vary with the cost, safety and reliability requirements of a given application.” Col. 14:65 – Col. 15:1.</p>

L. New Claim 49

`183 Patent Claim Language	`183 Patent Support
<p>49. The capacitive responsive electronic switching circuit as defined in claim 45, wherein each signal output frequency is selected from a plurality of Hertz values.</p>	<p>See Figure 11.</p> <p>The `183 Patent discloses “The touch detection circuit of the present invention features operation at frequencies at or above 50 kHz and preferably at or above 800 kHz to minimize the effects of surface contamination from materials such a [sic] skin oils and water. Col. 5:49-53.</p> <p>The `183 Patent discloses “Conversely, at 100 kHz, the glass impedance drops to approximately 1 MΩ resulting in the impedance of the path to ground for pad 59 being twice that of the touched pad 57. For cases where background noise and temperature drifts are</p>

`183 Patent Claim Language	`183 Patent Support
	<p>comparatively small, a 100 kHz oscillator frequency would allow a sufficiently low detection threshold to be set to differentiate between the signal changes induced at both pads by a human touch opposite a single pad. At 800 kHz, the impedance of the glass drops to 200 kΩ or lower giving a ratio of a greater than 5 to 1 impedance difference between the paths to ground of the touched pad 57 and adjacent pads 59. In fact, the impedance ratio may exceed 10 to 1, as illustrated in the calculation below. This allows the detection threshold for the touched pad to be set well below that of an adjacent pad resulting in a much lower incidence of inadvertent actuation of adjacent touch pads to that of the touched pad. Ideally, the frequency of operation would be kept at the 800 kHz of the preferred embodiment or even higher. However, as noted earlier, higher frequency operation forces the use of more expensive components and designs. For applications where thermal drift and electronic noise levels are low, operation at or near 100 kHz may be possible. However, at 10 kHz and below, the impedance of the glass becomes much greater than that of likely water bridges between pads resulting in adjacent pads being effected as much by a touch as the touched pad itself. Although the preferred frequency is at or above 100 kHz, and more preferably at or above 800 kHz, it is conceivable that frequencies as low as 50 kHz could be used provided the frequency creates a difference in the impedance paths of adjacent pads that is sufficient enough to accurately distinguish between an intended touch and the touch of an adjacent pad. Use of frequencies as low as 50 kHz may also be possible depending upon the type of glass or covering or the thickness thereof used for the touch pad. Col. 10:60 – Col. 11:27.</p> <p>The `183 Patent discloses “As will be apparent to those skilled in the art, the values of the resistors and capacitors utilized in oscillator 200 may be varied from those disclosed above to</p>

`183 Patent Claim Language	`183 Patent Support
	<p>provide for different oscillator output frequencies. As discussed above, however, oscillator 200 is preferably constructed so as to output a square wave having a frequency of 50 kHz or greater, and more preferably, of 800 kHz or greater. Col. 14:22-28.</p> <p>The `183 Patent disclosed “The combination of oscillator voltage, frequency and transistor gain bandwidth product that is used will necessarily vary with the cost, safety and reliability requirements of a given application.” Col. 14:65 – Col. 15:1.</p>

M. New Claim 50

`183 Patent Claim Language	`183 Patent Support
<p>50. The capacitive responsive electronic switching circuit as defined in claim 49, wherein the plurality of Hertz values comprises Hertz values greater than 50 kHz.</p>	<p>See Figure 11.</p> <p>The `183 Patent discloses “The touch detection circuit of the present invention features operation at frequencies at or above 50 kHz and preferably at or above 800 kHz to minimize the effects of surface contamination from materials such a [sic] skin oils and water. Col. 5:49-53.</p> <p>The `183 Patent discloses “Conversely, at 100 kHz, the glass impedance drops to approximately 1 MΩ resulting in the impedance of the path to ground for pad 59 being twice that of the touched pad 57. For cases where background noise and temperature drifts are comparatively small, a 100 kHz oscillator frequency would allow a sufficiently low detection threshold to be set to differentiate between the signal changes induced at both pads by a human touch opposite a single pad. At 800 kHz, the impedance of the glass drops to 200 kΩ or lower giving a ratio of a greater than 5 to 1 impedance difference between the paths to ground of the touched pad 57 and adjacent pads 59. In fact, the impedance ratio may exceed 10 to 1, as illustrated in the calculation below. This allows the detection threshold for the touched</p>

`183 Patent Claim Language	`183 Patent Support
	<p>pad to be set well below that of an adjacent pad resulting in a much lower incidence of inadvertent actuation of adjacent touch pads to that of the touched pad. Ideally, the frequency of operation would be kept at the 800 kHz of the preferred embodiment or even higher. However, as noted earlier, higher frequency operation forces the use of more expensive components and designs. For applications where thermal drift and electronic noise levels are low, operation at or near 100 kHz may be possible. However, at 10 kHz and below, the impedance of the glass becomes much greater than that of likely water bridges between pads resulting in adjacent pads being effected as much by a touch as the touched pad itself. Although the preferred frequency is at or above 100 kHz, and more preferably at or above 800 kHz, it is conceivable that frequencies as low as 50 kHz could be used provided the frequency creates a difference in the impedance paths of adjacent pads that is sufficient enough to accurately distinguish between an intended touch and the touch of an adjacent pad. Use of frequencies as low as 50 kHz may also be possible depending upon the type of glass or covering or the thickness thereof used for the touch pad. Col. 10:60 – Col. 11:27.</p> <p>The `183 Patent discloses “As will be apparent to those skilled in the art, the values of the resistors and capacitors utilized in oscillator 200 may be varied from those disclosed above to provide for different oscillator output frequencies. As discussed above, however, oscillator 200 is preferably constructed so as to output a square wave having a frequency of 50 kHz or greater, and more preferably, of 800 kHz or greater. Col. 14:22-28.</p> <p>The `183 Patent disclosed “The combination of oscillator voltage, frequency and transistor gain bandwidth product that is used will necessarily vary with the cost, safety and reliability requirements of a given application.” Col. 14:65</p>

`183 Patent Claim Language	`183 Patent Support
	– Col. 15:1.

N. New Claim 51

`183 Patent Claim Language	`183 Patent Support
<p>51. The capacitive responsive electronic switching circuit as defined in claim 49, wherein the plurality of Hertz values comprises Hertz values greater than 100 kHz.</p>	<p>See Figure 11.</p> <p>The `183 Patent discloses “The touch detection circuit of the present invention features operation at frequencies at or above 50 kHz and preferably at or above 800 kHz to minimize the effects of surface contamination from materials such a [sic] skin oils and water. Col. 5:49-53.</p> <p>The `183 Patent discloses “Conversely, at 100 kHz, the glass impedance drops to approximately 1 MΩ resulting in the impedance of the path to ground for pad 59 being twice that of the touched pad 57. For cases where background noise and temperature drifts are comparatively small, a 100 kHz oscillator frequency would allow a sufficiently low detection threshold to be set to differentiate between the signal changes induced at both pads by a human touch opposite a single pad. At 800 kHz, the impedance of the glass drops to 200 kΩ or lower giving a ratio of a greater than 5 to 1 impedance difference between the paths to ground of the touched pad 57 and adjacent pads 59. In fact, the impedance ratio may exceed 10 to 1, as illustrated in the calculation below. This allows the detection threshold for the touched pad to be set well below that of an adjacent pad resulting in a much lower incidence of inadvertent actuation of adjacent touch pads to that of the touched pad. Ideally, the frequency of operation would be kept at the 800 kHz of the preferred embodiment or even higher. However, as noted earlier, higher frequency operation forces the use of more expensive components and designs. For applications where thermal drift and electronic noise levels are low, operation at or near 100 kHz may be possible. However, at 10 kHz and below, the impedance of the glass</p>

`183 Patent Claim Language	`183 Patent Support
	<p>becomes much greater than that of likely water bridges between pads resulting in adjacent pads being effected as much by a touch as the touched pad itself. Although the preferred frequency is at or above 100 kHz, and more preferably at or above 800 kHz, it is conceivable that frequencies as low as 50 kHz could be used provided the frequency creates a difference in the impedance paths of adjacent pads that is sufficient enough to accurately distinguish between an intended touch and the touch of an adjacent pad. Use of frequencies as low as 50 kHz may also be possible depending upon the type of glass or covering or the thickness thereof used for the touch pad. Col. 10:60 – Col. 11:27.</p> <p>The `183 Patent discloses “As will be apparent to those skilled in the art, the values of the resistors and capacitors utilized in oscillator 200 may be varied from those disclosed above to provide for different oscillator output frequencies. As discussed above, however, oscillator 200 is preferably constructed so as to output a square wave having a frequency of 50 kHz or greater, and more preferably, of 800 kHz or greater. Col. 14:22-28.</p> <p>The `183 Patent disclosed “The combination of oscillator voltage, frequency and transistor gain bandwidth product that is used will necessarily vary with the cost, safety and reliability requirements of a given application.” Col. 14:65 – Col. 15:1.</p>

O. New Claim 52

`183 Patent Claim Language	`183 Patent Support
<p>52. The capacitive responsive electronic switching circuit as defined in claim 49, wherein the plurality of Hertz values comprises Hertz values greater than 800 kHz.</p>	<p>See Fig. 11.</p> <p>The `183 Patent discloses “The touch detection circuit of the present invention features operation at frequencies at or above 50 kHz and preferably at or above 800 kHz to minimize the effects of surface contamination from materials such a</p>

`183 Patent Claim Language	`183 Patent Support
	<p>[sic] skin oils and water. Col. 5:49-53.</p> <p>The `183 Patent discloses “At 800 kHz, the impedance of the glass drops to 200 kΩ or lower giving a ratio of a greater than 5 to 1 impedance difference between the paths to ground of the touched pad 57 and adjacent pads 59. In fact, the impedance ratio may exceed 10 to 1, as illustrated in the calculation below. This allows the detection threshold for the touched pad to be set well below that of an adjacent pad resulting in a much lower incidence of inadvertent actuation of adjacent touch pads to that of the touched pad. Ideally, the frequency of operation would be kept at the 800 kHz of the preferred embodiment or even higher. However, as noted earlier, higher frequency operation forces the use of more expensive components and designs. For applications where thermal drift and electronic noise levels are low, operation at or near 100 kHz may be possible. However, at 10 kHz and below, the impedance of the glass becomes much greater than that of likely water bridges between pads resulting in adjacent pads being effected as much by a touch as the touched pad itself. Although the preferred frequency is at or above 100 kHz, and more preferably at or above 800 kHz, it is conceivable that frequencies as low as 50 kHz could be used provided the frequency creates a difference in the impedance paths of adjacent pads that is sufficient enough to accurately distinguish between an intended touch and the touch of an adjacent pad. Use of frequencies as low as 50 kHz may also be possible depending upon the type of glass or covering or the thickness thereof used for the touch pad. Col. 11:1-27.</p> <p>The `183 Patent discloses “As will be apparent to those skilled in the art, the values of the resistors and capacitors utilized in oscillator 200 may be varied from those disclosed above to provide for different oscillator output frequencies. As discussed above, however,</p>

`183 Patent Claim Language	`183 Patent Support
	<p>oscillator 200 is preferably constructed so as to output a square wave having a frequency of 50 kHz or greater, and more preferably, of 800 kHz or greater. Col. 14:22-28.</p> <p>The `183 Patent disclosed “The combination of oscillator voltage, frequency and transistor gain bandwidth product that is used will necessarily vary with the cost, safety and reliability requirements of a given application.” Col. 14:65 – Col. 15:1.</p>

P. New Claim 53

`183 Patent Claim Language	`183 Patent Support
<p>53. The capacitive responsive electronic switching circuit as defined in claim 45, wherein a peak voltage of the signal output frequencies is greater than a supply voltage.</p>	<p>See Figures 4, 5; Claims 27 and 37.</p> <p>The `183 Patent discloses “Having provided a basis for the use of higher frequencies, the basic construction of the electronic switching circuit constructed in accordance with a first embodiment of the present invention is now described with reference to FIG. 4. The electronic switching circuit includes a voltage regulator 100 including input lines 101 and 102 for receiving a 24 V AC line voltage and a line 103 for grounding the circuit. Voltage regulator 100 converts the received AC voltage to a DC voltage and supplies a regulated 5 V DC power to an oscillator 200 via lines 104 and 105. Voltage regulator also supplies oscillator 200 with 26 V DC power via line 106. The details of voltage regulator 100 are discussed below with reference to FIG. 5.</p> <p>Upon being powered by voltage regulator 100, oscillator 200 generates a square wave with a frequency of 50 kHz, and preferably greater than 800 kHz, and having an amplitude of 26 V peak. The square wave generated by oscillator 200 is supplied via line 201 to a floating common generator 300, a touch pad shield plate 460, a touch circuit 400, and a microcontroller 500. Oscillator 200 is described below with reference to FIG. 6.” Col. 11:60 – Col. 12:13.</p>

`183 Patent Claim Language	`183 Patent Support
	<p>The `183 Patent discloses “Microcontroller 500 selects each row of the touch circuits 900₁ to 900_{nm} by providing the signal from oscillator 200 to selected rows of touch circuits. In this manner, microcontroller 500 can sequentially activate the touch circuit rows and associate the received inputs from the columns of the array with the activated touch circuit(s).” Col. 18:43-49.</p> <p>The `183 Patent discloses “A preferred circuit for implementing a voltage regulator 100 is shown in FIG. 5. Voltage regulator 100 preferably includes an AC/DC convertor 110 for generating 29 V to 36 V unregulated DC on line 119. This unregulated DC power is supplied to a 5 V DC regulator 120 and to a 26 V DC regulator 130. AC/DC convertor 110 includes diodes 112, 114, 116, and 118, which rectify the supplied 24 V AC power provided on power lines 101 and 102.” Col. 12:50-57; see also Col. 12:57 – Col. 13:31.</p> <p>The `183 Patent discloses “The oscillator circuitry shown in FIG. 6 is very stable over the temperature range of -40° C. to 105° C. The output of the touch switch circuitry drops at a rate of approximately 40 mV/°C. when temperature falls below 0° C. If application requires operation at low temperatures (-40° C.), the following three methods may be used to increase the output of the switch: increase the oscillator’s regulated supply voltage, increase the resistance of resistor 416, and use a higher gain transistor 410. All of these methods would increase sensitivity at high temperatures.” Col. 16:33-41.</p>

Q. New Claim 54

`183 Patent Claim Language	`183 Patent Support
54. The capacitive responsive	The `183 Patent discloses “It will be apparent to

`183 Patent Claim Language	`183 Patent Support
electronic switching circuit as defined in claim 53, wherein the supply voltage is a battery supply voltage.	those skilled in the art, that various components of voltage regulator 100 may be added or excluded depending upon the source of power available to power the oscillator 200. For example, if the available power is a 110 V AC 60 Hz commercial power line, a transformer may be added to convert the 100 V AC power to 24 V AC. Alternatively, if a DC batter is used, the AC/DC convertor among other components may be eliminated.” Col 13:23-31.

R. New Claim 55

`183 Patent Claim Language	`183 Patent Support
55. The capacitive responsive electronic switching circuit as defined in claim 53, wherein the supply voltage is a voltage regulator supply voltage.	Figures 4, 5, 11, and 12. The `183 Patent discloses “The electronic switching circuit includes a voltage regulator 100 including input lines 101 and 102 for receiving a 24 V AC line voltage and a line 103 for grounding the circuit. Voltage regulator 100 converts the received AC voltage to a DC voltage and supplies a regulated 5 V DC power to an oscillator 200 via lines 104 and 105. Voltage regulator also supplies oscillator 200 with 26 V DC power via line 106. The details of voltage regulator 100 are discussed below with reference to FIG. 5.” Col. 11:64 – Col. 12:5; see also Col. 12:50 – Col. 13:31.

S. New Claim 56

For ease of analysis, new independent claim 56 is shown below with pseudo-amendments illustrating the differences between new claim 56 and claim 18 of the `183 Patent following the first reexamination proceeding.

`183 Patent Claim Language	`183 Patent Support
56. A capacitive responsive electronic switching circuit comprising:	See Claim 18.
an oscillator providing a periodic output signal having a predefined	See Claim 18.

`183 Patent Claim Language	`183 Patent Support
frequency;	
<p>a microcontroller using the periodic output signal from the oscillator, the microcontroller selectively providing signal output frequencies to a plurality of small sized input touch terminals of a keypad, <u>wherein the selectively providing comprises the microcontroller selectively providing a signal output frequency to each row of the plurality of small sized input touch terminals of the keypad, and wherein a peak voltage of the signal output frequencies is greater than a supply voltage;</u></p>	<p>See Figures 4, 5, 11; and Claims 8, 12, 16, 18, 27 and 37.</p> <p>The `183 Patent discloses “The touch detection circuit of the present invention features operation at frequencies at or above 50kHz and preferably at or above 800 kHz to minimize the effects of surface contamination from materials such a [sic] skin oils and water. It also offers improvements in detection sensitivity that allow close control of the degree of proximity (ideally very close proximity) that is required for actuation and to enable employment of a multiplicity of small sized touch terminals in a physically close array such as a keyboard.” Col. 5:49-57.</p> <p>The `183 Patent discloses “In a first preferred embodiment the circuit offers enhanced detection sensitivity to allow reliable operation with small (finger size) touch pads.” Col. 6:1-3.</p> <p>The `183 Patent discloses “Although the preferred frequency is at or above 100 kHz, and more preferably at or above 800 kHz, it is conceivable that frequencies as low as 50 kHz could be used provided the frequency creates a difference in the impedance paths of adjacent pads that is sufficient enough to accurately distinguish between an intended touch and the touch of an adjacent pad. Use of frequencies as low as 50 kHz may also be possible depending upon the type of glass or covering or the thickness thereof used for the touch pad.” Col. 11:19-27.</p> <p>The `183 Patent discloses “Having provided a basis for the use of higher frequencies, the basic construction of the electronic switching circuit constructed in accordance with a first embodiment of the present invention is now described with reference to FIG. 4. The electronic switching circuit includes a voltage</p>

`183 Patent Claim Language	`183 Patent Support
	<p>regulator 100 including input lines 101 and 102 for receiving a 24 V AC line voltage and a line 103 for grounding the circuit. Voltage regulator 100 converts the received AC voltage to a DC voltage and supplies a regulated 5 V DC power to an oscillator 200 via lines 104 and 105. Voltage regulator also supplies oscillator 200 with 26 V DC power via line 106. The details of voltage regulator 100 are discussed below with reference to FIG. 5.</p> <p>Upon being powered by voltage regulator 100, oscillator 200 generates a square wave with a frequency of 50 kHz, and preferably greater than 800 kHz, and having an amplitude of 26 V peak. The square wave generated by oscillator 200 is supplied via line 201 to a floating common generator 300, a touch pad shield plate 460, a touch circuit 400, and a microcontroller 500. Oscillator 200 is described below with reference to FIG. 6.</p> <p>Floating common generator 300 receives the 26 V peak square wave from oscillator 200 and outputs a regulated floating common that is 5 volts below the square wave output from oscillator 200 and has the same phase and frequency as the received square wave. This floating common output is supplied to touch circuit 400 and microcontroller 500 via line 301 such that the output square wave from oscillator 200 and floating common output from floating common generator 300 provide power to touch circuit 400 and microcontroller 500. Details of floating common generator 300 are discussed below with reference to FIG. 7.</p> <p>Touch circuit 400 senses capacitance from a touch pad 450 via line 451 and outputs a signal to microcontroller 500 via line 401 upon detecting a capacitance to ground at touch pad 450 that exceeds a threshold value. The details of touch circuit 400 are described below with reference to FIG. 8.</p> <p>Upon receiving an indication from touch circuit 400 that a sufficient capacitance to ground (typically at least 20 pF) is present at touch pad</p>

`183 Patent Claim Language	`183 Patent Support
	<p>450, microcontroller 500 outputs a signal to a load-controlling microcontroller 600 via line 501, which is preferably a two way optical coupling bus.” Col. 11:60 – 12:33.</p> <p>The `183 Patent discloses “A preferred circuit for implementing a voltage regulator 100 is shown in FIG. 5. Voltage regulator 100 preferably includes an AC/DC converter 110 for generating 29 V to 36 V unregulated DC on line 119. This unregulated DC power is supplied to a 5 V DC regulator 120 and to a 26 V DC regulator 130. AC/DC converter 110 includes diodes 112, 114, 116, and 118, which rectify the supplied 24 V AC power provided on power lines 101 and 102.” Col. 12:50-57; see also Col. 12:57 – Col. 13:31.</p> <p>The `183 Patent discloses “As will be apparent to those skilled in the art, the values of the resistors and capacitors utilized in oscillator 200 may be varied from those disclosed above to provide for different oscillator output frequencies.” Col. 14:22-25.</p> <p>The `183 Patent discloses “The oscillator circuitry shown in FIG. 6 is very stable over the temperature range of -40° C. to 105° C. The output of the touch switch circuitry drops at a rate of approximately 40 mV/°C. when temperature falls below 0° C. If application requires operation at low temperatures (-40° C.), the following three methods may be used to increase the output of the switch: increase the oscillator’s regulated supply voltage, increase the resistance of resistor 416, and use a higher gain transistor 410. All of these methods would increase sensitivity at high temperatures.” Col. 16:33-41.</p> <p>The `183 Patent discloses “A multiple touch pad circuit constructed in accordance with the second embodiment is shown in FIG. 11. In the second embodiment of FIG. 11, components</p>

`183 Patent Claim Language	`183 Patent Support
	<p>similar to those in the first embodiment in FIG. 4 are designated with the same references numerals and will not be discussed in detail. The multiple touch pad circuit is a variation of the first embodiment in that it includes an array of touch circuits designated as 900₁ through 900_{nm}, which, as shown, include both the touch circuit 400 shown in FIGS. 4 and 8 and the input touch terminal pad 451 (FIG. 4). Microcontroller 500 selects each row of the touch circuits 900₁ to 900_{nm} by providing the signal from oscillator 200 to selected rows of touch circuits. In this manner, microcontroller 500 can sequentially activate the touch circuit rows and associate the received inputs from the columns of the array with the activated touch circuit(s). To keep the path length 451 between the touch pad 450 and the base to the detection transistor 410 to a minimum, the detection circuits 900 are physically located directly beneath the touch pads. To simplify assembly, a flexible circuit board such as vended by Sheldahl, Inc. or Circuit Etching Technics, Inc. can be used for this purpose. Ideally, the printed circuit will be fixed directly against the surface (typically glass) bearing the conductive touch pads to eliminate air gaps and the need for conductive foam pads and spring contacts which were used to fill air gaps.” Col. 18:34-59.</p>
<p>the plurality of small sized input touch terminals defining adjacent areas on a dielectric substrate for an operator to provide inputs by proximity and touch; and</p>	<p>See Claim 18.</p>
<p>a detector circuit coupled to said oscillator for receiving said periodic output signal from said oscillator, and coupled to said input touch terminals, said detector circuit being responsive to signals from said oscillator via said microcontroller and a presence of an operator's body capacitance to ground coupled to said touch terminals when</p>	<p>See Claim 18.</p>

`183 Patent Claim Language	`183 Patent Support
proximal or touched by the operator to provide a control output signal,	
wherein said predefined frequency of said oscillator and said signal output frequencies are selected to decrease a first impedance of said dielectric substrate relative to a second impedance of any contaminate that may create an electrical path on said dielectric substrate between said adjacent areas defined by the plurality of small sized input touch terminals, and wherein said detector circuit compares a sensed body capacitance change to ground proximate an input touch terminal to a threshold level to prevent inadvertent generation of the control output signal.	See Claim 18.

T. New Claim 57

For ease of analysis, new dependent claim 57 is shown below with pseudo-amendments illustrating the differences between new claim 57 and claim 33 of the `183 Patent following the first reexamination proceeding.

`183 Patent Claim Language	`183 Patent Support
57. The capacitive responsive electronic switching circuit as defined in claim 56, further comprising wherein said detector circuit compares the sensed body capacitance change to <u>ground proximate the input touch terminal</u> is caused by the <u>operator's</u> body capacitance decreasing an input touch terminal signal on the detector <u>circuit, and wherein the sensed body capacitance change</u> to ground when proximate to the input touch terminal is compared to a second threshold level to generate the control output signal.	See Claims 1, 18, 28, and 33. The `183 Patent discloses “The touch detection circuit of the present invention features operation at frequencies at or above 50 kHz and preferably at or above 800 kHz to minimize the effects of surface contamination from materials such a [sic] skin oils and water. It also offers improvements in detection sensitivity that allow close control of the degree of proximity (ideally very close proximity) that is required for actuation and to enable employment of a multiplicity of small sized touch terminals in a physically close array such as a keyboard.” Col. 5:49-57.

`183 Patent Claim Language	`183 Patent Support
	<p>The `183 Patent discloses “Touch circuit 400 senses capacitance from a touch pad 450 via line 451 and outputs a signal to microcontroller 500 via line 401 upon detecting a capacitance to ground at touch pad 450 that exceeds a threshold value. The details of touch circuit 400 are described below with reference to FIG. 8.” Col. 12:24-28.</p> <p>The `183 Patent discloses “As can be seen, at 1 kHz, the capacitive impedance of the glass is much greater than the nominal 1 MΩ of the water bridge across the pads. As a result, at 1 kHz, there would be little difference in the impedance paths to ground of the two adjacent pads when either is touched. This would result in the voltage on both pads being pulled towards ground by comparable amounts. Conversely, at 100 kHz, the glass impedance drops to approximately 1 MΩ resulting in the impedance of the path to ground for pad 59 being twice that of the touched pad 57. For cases where background noise and temperature drifts are comparatively small, a 100 kHz oscillator frequency would allow a sufficiently low detection threshold to be set to differentiate between the signal changes induced at both pads by a human touch opposite a single pad. At 800 kHz, the impedance of the glass drops to 200 kΩ or lower giving a ratio of a greater than 5 to 1 impedance difference between the paths to ground of the touched pad 57 and adjacent pads 59. In fact, the impedance ratio may exceed 10 to 1, as illustrated in the calculation below. This allows the detection threshold for the touched pad to be set well below that of an adjacent pad resulting in a much lower incidence of inadvertent actuation of adjacent touch pads to that of the touched pad. Col. 10:54 – Col. 11:9.</p> <p>The `183 Patent discloses “As stated above, the operator’s body includes a capacitance to ground, which may range in a typical person from between 20 to 300 pF. The base terminal</p>

`183 Patent Claim Language	`183 Patent Support
	<p>of transistor 410 is coupled to it's [sic] emitter by resistor 412 such that unless capacitance is present by the user touching the touch pad 450, transistor 410 will not be forward biased and will not conduct. Thus, when touch pad 450 is not touched, the output signal at the collector terminal of transistor 410 and across pulse stretcher circuit 417 will be zero volts. When, however, a person touches the touch pad 450, that person's body capacitance to ground couples the base of transistor 410 to ground 103 through resistor 413, thereby forward biasing transistor 410 into conduction. This charges capacitor 418 providing a positive DC voltage with respect to the line 301 and causes the output of the Schmitt trigger 420 to go low. Diode 414 is coupled across the base to emitter junction of transistor 410 to clamp the base emitter reverse bias voltage to -0.7V and also reduce the forward recovery and turn-on time. Col. 15:29-47.</p>

U. New Claim 58

For ease of analysis, new dependent claim 58 is shown below with pseudo-amendments illustrating the differences between new claim 58 and claim 34 of the `183 Patent following the first reexamination proceeding.

`183 Patent Claim Language	`183 Patent Support
<p>58. The capacitive responsive electronic switching circuit as defined in claim 56, further comprising wherein said detector circuit compares the sensed body capacitance change <u>to ground proximate the input touch terminal</u> is caused by the <u>operator's</u> body capacitance decreasing an input touch terminal signal amplitude on the detector <u>circuit, and wherein the sensed body capacitance change to ground when proximate to the input touch terminal is compared</u> to a second threshold level to generate the control output signal.</p>	<p>See Claims 1, 18, 28, and 34.</p> <p>The `183 Patent discloses "Another method for implementing capacitive touch switches relies on the change in capacitive coupling between a touch terminal and ground. Systems utilizing such a method are described in U.S. Pat. No. 4,758,735 and U.S. Pat. No. 5,087,825. With this methodology the detection circuit consists of an oscillator (or AC line voltage derivative) providing a signal to a touch terminal whose voltage is then monitored by a detector. The touch terminal is driven in electrical series with other components that function in part as a charge pump. The touch of an operator then</p>

`183 Patent Claim Language	`183 Patent Support
	<p>provides a capacitive short to ground via the operator's own body capacitance that lowers the amplitude of oscillator voltage seen at the touch terminal.” Col. 3:44-56.</p> <p>The `183 Patent discloses “The touch detection circuit of the present invention features operation at frequencies at or above 50 kHz and preferably at or above 800 kHz to minimize the effects of surface contamination from materials such a [sic] skin oils and water. It also offers improvements in detection sensitivity that allow close control of the degree of proximity (ideally very close proximity) that is required for actuation and to enable employment of a multiplicity of small sized touch terminals in a physically close array such as a keyboard.” Col. 5:49-57.</p> <p>The `183 Patent discloses “Touch circuit 400 senses capacitance from a touch pad 450 via line 451 and outputs a signal to microcontroller 500 via line 401 upon detecting a capacitance to ground at touch pad 450 that exceeds a threshold value. The details of touch circuit 400 are described below with reference to FIG. 8.” Col. 12:24-28.</p> <p>The `183 Patent discloses “As can be seen, at 1 kHz, the capacitive impedance of the glass is much greater than the nominal 1 MΩ of the water bridge across the pads. As a result, at 1 kHz, there would be little difference in the impedance paths to ground of the two adjacent pads when either is touched. This would result in the voltage on both pads being pulled towards ground by comparable amounts. Conversely, at 100 kHz, the glass impedance drops to approximately 1 MΩ resulting in the impedance of the path to ground for pad 59 being twice that of the touched pad 57. For cases where background noise and temperature drifts are comparatively small, a 100 kHz oscillator frequency would allow a sufficiently low</p>

`183 Patent Claim Language	`183 Patent Support
	<p>detection threshold to be set to differentiate between the signal changes induced at both pads by a human touch opposite a single pad. At 800 kHz, the impedance of the glass drops to 200 kΩ or lower giving a ratio of a greater than 5 to 1 impedance difference between the paths to ground of the touched pad 57 and adjacent pads 59. In fact, the impedance ratio may exceed 10 to 1, as illustrated in the calculation below. This allows the detection threshold for the touched pad to be set well below that of an adjacent pad resulting in a much lower incidence of inadvertent actuation of adjacent touch pads to that of the touched pad. Col. 10:54 – Col. 11:9.</p> <p>The `183 Patent discloses “As stated above, the operator’s body includes a capacitance to ground, which may range in a typical person from between 20 to 300 pF. The base terminal of transistor 410 is coupled to it’s [sic] emitter by resistor 412 such that unless capacitance is present by the user touching the touch pad 450, transistor 410 will not be forward biased and will not conduct. Thus, when touch pad 450 is not touched, the output signal at the collector terminal of transistor 410 and across pulse stretcher circuit 417 will be zero volts. When, however, a person touches the touch pad 450, that person’s body capacitance to ground couples the base of transistor 410 to ground 103 through resistor 413, thereby forward biasing transistor 410 into conduction. This charges capacitor 418 providing a positive DC voltage with respect to the line 301 and causes the output of the Schmitt trigger 420 to go low. Diode 414 is coupled across the base to emitter junction of transistor 410 to clamp the base emitter reverse bias voltage to –0.7V and also reduce the forward recovery and turn-on time. Col. 15:29-47.</p>

V. New Claim 59

`183 Patent Claim Language	`183 Patent Support
59. The capacitive responsive	See Figure 11.

`183 Patent Claim Language	`183 Patent Support
<p>electronic switching circuit as defined in claim 56, wherein each signal output frequency selectively provided to each row of the plurality of small sized input touch terminals of the keypad has a same Hertz value.</p>	<p>The `183 Patent discloses “The touch detection circuit of the present invention features operation at frequencies at or above 50 kHz and preferably at or above 800 kHz to minimize the effects of surface contamination from materials such a [sic] skin oils and water. Col. 5:49-53.</p> <p>The `183 Patent discloses “Conversely, at 100 kHz, the glass impedance drops to approximately 1 MΩ resulting in the impedance of the path to ground for pad 59 being twice that of the touched pad 57. For cases where background noise and temperature drifts are comparatively small, a 100 kHz oscillator frequency would allow a sufficiently low detection threshold to be set to differentiate between the signal changes induced at both pads by a human touch opposite a single pad. At 800 kHz, the impedance of the glass drops to 200 kΩ or lower giving a ratio of a greater than 5 to 1 impedance difference between the paths to ground of the touched pad 57 and adjacent pads 59. In fact, the impedance ratio may exceed 10 to 1, as illustrated in the calculation below. This allows the detection threshold for the touched pad to be set well below that of an adjacent pad resulting in a much lower incidence of inadvertent actuation of adjacent touch pads to that of the touched pad. Ideally, the frequency of operation would be kept at the 800 kHz of the preferred embodiment or even higher. However, as noted earlier, higher frequency operation forces the use of more expensive components and designs. For applications where thermal drift and electronic noise levels are low, operation at or near 100 kHz may be possible. However, at 10 kHz and below, the impedance of the glass becomes much greater than that of likely water bridges between pads resulting in adjacent pads being effected as much by a touch as the touched pad itself. Although the preferred frequency is at or above 100 kHz, and more preferably at or above 800 kHz, it is conceivable that frequencies</p>

`183 Patent Claim Language	`183 Patent Support
	<p>as low as 50 kHz could be used provided the frequency creates a difference in the impedance paths of adjacent pads that is sufficient enough to accurately distinguish between an intended touch and the touch of an adjacent pad. Use of frequencies as low as 50 kHz may also be possible depending upon the type of glass or covering or the thickness thereof used for the touch pad. Col. 10:60 – Col. 11:27.</p> <p>The `183 Patent discloses “As will be apparent to those skilled in the art, the values of the resistors and capacitors utilized in oscillator 200 may be varied from those disclosed above to provide for different oscillator output frequencies. As discussed above, however, oscillator 200 is preferably constructed so as to output a square wave having a frequency of 50 kHz or greater, and more preferably, of 800 kHz or greater. Col. 14:22-28.</p> <p>The `183 Patent disclosed “The combination of oscillator voltage, frequency and transistor gain bandwidth product that is used will necessarily vary with the cost, safety and reliability requirements of a given application.” Col. 14:65 – Col. 15:1.</p>

W. New Claim 60

`183 Patent Claim Language	`183 Patent Support
<p>60. The capacitive responsive electronic switching circuit as defined in claim 56, wherein each signal output frequency selectively provided to each row of the plurality of small sized input touch terminals of the keypad is selected from a plurality of Hertz values.</p>	<p>See Figure 11.</p> <p>The `183 Patent discloses “The touch detection circuit of the present invention features operation at frequencies at or above 50 kHz and preferably at or above 800 kHz to minimize the effects of surface contamination from materials such a [sic] skin oils and water. Col. 5:49-53.</p> <p>The `183 Patent discloses “Conversely, at 100 kHz, the glass impedance drops to approximately 1 MΩ resulting in the impedance of the path to ground for pad 59 being twice that</p>

`183 Patent Claim Language	`183 Patent Support
	<p>of the touched pad 57. For cases where background noise and temperature drifts are comparatively small, a 100 kHz oscillator frequency would allow a sufficiently low detection threshold to be set to differentiate between the signal changes induced at both pads by a human touch opposite a single pad. At 800 kHz, the impedance of the glass drops to 200 kΩ or lower giving a ratio of a greater than 5 to 1 impedance difference between the paths to ground of the touched pad 57 and adjacent pads 59. In fact, the impedance ratio may exceed 10 to 1, as illustrated in the calculation below. This allows the detection threshold for the touched pad to be set well below that of an adjacent pad resulting in a much lower incidence of inadvertent actuation of adjacent touch pads to that of the touched pad. Ideally, the frequency of operation would be kept at the 800 kHz of the preferred embodiment or even higher. However, as noted earlier, higher frequency operation forces the use of more expensive components and designs. For applications where thermal drift and electronic noise levels are low, operation at or near 100 kHz may be possible. However, at 10 kHz and below, the impedance of the glass becomes much greater than that of likely water bridges between pads resulting in adjacent pads being effected as much by a touch as the touched pad itself. Although the preferred frequency is at or above 100 kHz, and more preferably at or above 800 kHz, it is conceivable that frequencies as low as 50 kHz could be used provided the frequency creates a difference in the impedance paths of adjacent pads that is sufficient enough to accurately distinguish between an intended touch and the touch of an adjacent pad. Use of frequencies as low as 50 kHz may also be possible depending upon the type of glass or covering or the thickness thereof used for the touch pad. Col. 10:60 – Col. 11:27.</p> <p>The `183 Patent discloses “As will be apparent to those skilled in the art, the values of the</p>

`183 Patent Claim Language	`183 Patent Support
	<p>resistors and capacitors utilized in oscillator 200 may be varied from those disclosed above to provide for different oscillator output frequencies. As discussed above, however, oscillator 200 is preferably constructed so as to output a square wave having a frequency of 50 kHz or greater, and more preferably, of 800 kHz or greater. Col. 14:22-28.</p> <p>The `183 Patent disclosed “The combination of oscillator voltage, frequency and transistor gain bandwidth product that is used will necessarily vary with the cost, safety and reliability requirements of a given application.” Col. 14:65 – Col. 15:1.</p>

X. New Claim 61

`183 Patent Claim Language	`183 Patent Support
<p>61. The capacitive responsive electronic switching circuit as defined in claim 60, wherein the plurality of Hertz values comprises Hertz values greater than 50 kHz.</p>	<p>See Figure 11.</p> <p>The `183 Patent discloses “The touch detection circuit of the present invention features operation at frequencies at or above 50 kHz and preferably at or above 800 kHz to minimize the effects of surface contamination from materials such a [sic] skin oils and water. Col. 5:49-53.</p> <p>The `183 Patent discloses “Conversely, at 100 kHz, the glass impedance drops to approximately 1 MΩ resulting in the impedance of the path to ground for pad 59 being twice that of the touched pad 57. For cases where background noise and temperature drifts are comparatively small, a 100 kHz oscillator frequency would allow a sufficiently low detection threshold to be set to differentiate between the signal changes induced at both pads by a human touch opposite a single pad. At 800 kHz, the impedance of the glass drops to 200 kΩ or lower giving a ratio of a greater than 5 to 1 impedance difference between the paths to ground of the touched pad 57 and adjacent pads 59. In fact, the impedance ratio may exceed 10</p>

`183 Patent Claim Language	`183 Patent Support
	<p>to 1, as illustrated in the calculation below. This allows the detection threshold for the touched pad to be set well below that of an adjacent pad resulting in a much lower incidence of inadvertent actuation of adjacent touch pads to that of the touched pad. Ideally, the frequency of operation would be kept at the 800 kHz of the preferred embodiment or even higher. However, as noted earlier, higher frequency operation forces the use of more expensive components and designs. For applications where thermal drift and electronic noise levels are low, operation at or near 100 kHz may be possible. However, at 10 kHz and below, the impedance of the glass becomes much greater than that of likely water bridges between pads resulting in adjacent pads being effected as much by a touch as the touched pad itself. Although the preferred frequency is at or above 100 kHz, and more preferably at or above 800 kHz, it is conceivable that frequencies as low as 50 kHz could be used provided the frequency creates a difference in the impedance paths of adjacent pads that is sufficient enough to accurately distinguish between an intended touch and the touch of an adjacent pad. Use of frequencies as low as 50 kHz may also be possible depending upon the type of glass or covering or the thickness thereof used for the touch pad. Col. 10:60 – Col. 11:27.</p> <p>The `183 Patent discloses “As will be apparent to those skilled in the art, the values of the resistors and capacitors utilized in oscillator 200 may be varied from those disclosed above to provide for different oscillator output frequencies. As discussed above, however, oscillator 200 is preferably constructed so as to output a square wave having a frequency of 50 kHz or greater, and more preferably, of 800 kHz or greater. Col. 14:22-28.</p> <p>The `183 Patent disclosed “The combination of oscillator voltage, frequency and transistor gain bandwidth product that is used will necessarily</p>

`183 Patent Claim Language	`183 Patent Support
	vary with the cost, safety and reliability requirements of a given application.” Col. 14:65 – Col. 15:1.

Y. New Claim 62

`183 Patent Claim Language	`183 Patent Support
<p>62. The capacitive responsive electronic switching circuit as defined in claim 60, wherein the plurality of Hertz values comprises Hertz values greater than 100 kHz.</p>	<p>See Figure 11.</p> <p>The `183 Patent discloses “The touch detection circuit of the present invention features operation at frequencies at or above 50 kHz and preferably at or above 800 kHz to minimize the effects of surface contamination from materials such a [sic] skin oils and water. Col. 5:49-53.</p> <p>The `183 Patent discloses “Conversely, at 100 kHz, the glass impedance drops to approximately 1 MΩ resulting in the impedance of the path to ground for pad 59 being twice that of the touched pad 57. For cases where background noise and temperature drifts are comparatively small, a 100 kHz oscillator frequency would allow a sufficiently low detection threshold to be set to differentiate between the signal changes induced at both pads by a human touch opposite a single pad. At 800 kHz, the impedance of the glass drops to 200 kΩ or lower giving a ratio of a greater than 5 to 1 impedance difference between the paths to ground of the touched pad 57 and adjacent pads 59. In fact, the impedance ratio may exceed 10 to 1, as illustrated in the calculation below. This allows the detection threshold for the touched pad to be set well below that of an adjacent pad resulting in a much lower incidence of inadvertent actuation of adjacent touch pads to that of the touched pad. Ideally, the frequency of operation would be kept at the 800 kHz of the preferred embodiment or even higher. However, as noted earlier, higher frequency operation forces the use of more expensive components and designs. For applications where thermal drift and electronic noise levels are low, operation at</p>

`183 Patent Claim Language	`183 Patent Support
	<p>or near 100 kHz may be possible. However, at 10 kHz and below, the impedance of the glass becomes much greater than that of likely water bridges between pads resulting in adjacent pads being effected as much by a touch as the touched pad itself. Although the preferred frequency is at or above 100 kHz, and more preferably at or above 800 kHz, it is conceivable that frequencies as low as 50 kHz could be used provided the frequency creates a difference in the impedance paths of adjacent pads that is sufficient enough to accurately distinguish between an intended touch and the touch of an adjacent pad. Use of frequencies as low as 50 kHz may also be possible depending upon the type of glass or covering or the thickness thereof used for the touch pad. Col. 10:60 – Col. 11:27.</p> <p>The `183 Patent discloses “As will be apparent to those skilled in the art, the values of the resistors and capacitors utilized in oscillator 200 may be varied from those disclosed above to provide for different oscillator output frequencies. As discussed above, however, oscillator 200 is preferably constructed so as to output a square wave having a frequency of 50 kHz or greater, and more preferably, of 800 kHz or greater. Col. 14:22-28.</p> <p>The `183 Patent disclosed “The combination of oscillator voltage, frequency and transistor gain bandwidth product that is used will necessarily vary with the cost, safety and reliability requirements of a given application.” Col. 14:65 – Col. 15:1.</p>

Z. New Claim 63

`183 Patent Claim Language	`183 Patent Support
<p>63. The capacitive responsive electronic switching circuit as defined in claim 60, wherein the plurality of Hertz values comprises Hertz values greater</p>	<p>See Fig. 11.</p> <p>The `183 Patent discloses “The touch detection circuit of the present invention features operation at frequencies at or above 50 kHz and preferably</p>

`183 Patent Claim Language	`183 Patent Support
<p>than 800 kHz.</p>	<p>at or above 800 kHz to minimize the effects of surface contamination from materials such a [sic] skin oils and water. Col. 5:49-53.</p> <p>The `183 Patent discloses “At 800 kHz, the impedance of the glass drops to 200 kΩ or lower giving a ratio of a greater than 5 to 1 impedance difference between the paths to ground of the touched pad 57 and adjacent pads 59. In fact, the impedance ratio may exceed 10 to 1, as illustrated in the calculation below. This allows the detection threshold for the touched pad to be set well below that of an adjacent pad resulting in a much lower incidence of inadvertent actuation of adjacent touch pads to that of the touched pad. Ideally, the frequency of operation would be kept at the 800 kHz of the preferred embodiment or even higher. However, as noted earlier, higher frequency operation forces the use of more expensive components and designs. For applications where thermal drift and electronic noise levels are low, operation at or near 100 kHz may be possible. However, at 10 kHz and below, the impedance of the glass becomes much greater than that of likely water bridges between pads resulting in adjacent pads being effected as much by a touch as the touched pad itself. Although the preferred frequency is at or above 100 kHz, and more preferably at or above 800 kHz, it is conceivable that frequencies as low as 50 kHz could be used provided the frequency creates a difference in the impedance paths of adjacent pads that is sufficient enough to accurately distinguish between an intended touch and the touch of an adjacent pad. Use of frequencies as low as 50 kHz may also be possible depending upon the type of glass or covering or the thickness thereof used for the touch pad. Col. 11:1-27.</p> <p>The `183 Patent discloses “As will be apparent to those skilled in the art, the values of the resistors and capacitors utilized in oscillator 200 may be varied from those disclosed above to</p>

`183 Patent Claim Language	`183 Patent Support
	<p>provide for different oscillator output frequencies. As discussed above, however, oscillator 200 is preferably constructed so as to output a square wave having a frequency of 50 kHz or greater, and more preferably, of 800 kHz or greater. Col. 14:22-28.</p> <p>The `183 Patent disclosed “The combination of oscillator voltage, frequency and transistor gain bandwidth product that is used will necessarily vary with the cost, safety and reliability requirements of a given application.” Col. 14:65 – Col. 15:1.</p>

AA. New Claim 64

`183 Patent Claim Language	`183 Patent Support
<p>64. The capacitive responsive electronic switching circuit as defined in claim 56, wherein the supply voltage is a battery supply voltage.</p>	<p>The `183 Patent discloses “It will be apparent to those skilled in the art, that various components of voltage regulator 100 may be added or excluded depending upon the source of power available to power the oscillator 200. For example, if the available power is a 110 V AC 60 Hz commercial power line, a transformer may be added to convert the 100 V AC power to 24 V AC. Alternatively, if a DC batter is used, the AC/DC convertor among other components may be eliminated.” Col 13:23-31.</p>

BB. New Claim 65

`183 Patent Claim Language	`183 Patent Support
<p>65. The capacitive responsive electronic switching circuit as defined in claim 56, wherein the supply voltage is a voltage regulator supply voltage.</p>	<p>Figures 4, 5, 11, and 12.</p> <p>The `183 Patent discloses “The electronic switching circuit includes a voltage regulator 100 including input lines 101 and 102 for receiving a 24 V AC line voltage and a line 103 for grounding the circuit. Voltage regulator 100 converts the received AC voltage to a DC voltage and supplies a regulated 5 V DC power to an oscillator 200 via lines 104 and 105. Voltage regulator also supplies oscillator 200</p>

`183 Patent Claim Language	`183 Patent Support
	with 26 V DC power via line 106. The details of voltage regulator 100 are discussed below with reference to FIG. 5.” Col. 11:64 – Col. 12:5; see also Col. 12:50 – Col. 13:31.

CC. New Claim 66

`183 Patent Claim Language	`183 Patent Support
<p>66. The capacitive responsive electronic switching circuit as defined in claim 111, wherein each signal output frequency selectively provided to each row of the closely spaced array of input touch terminals of the keypad has a same Hertz value.</p>	<p>See Figure 11.</p> <p>The `183 Patent discloses “The touch detection circuit of the present invention features operation at frequencies at or above 50 kHz and preferably at or above 800 kHz to minimize the effects of surface contamination from materials such a [sic] skin oils and water. Col. 5:49-53.</p> <p>The `183 Patent discloses “Conversely, at 100 kHz, the glass impedance drops to approximately 1 MΩ resulting in the impedance of the path to ground for pad 59 being twice that of the touched pad 57. For cases where background noise and temperature drifts are comparatively small, a 100 kHz oscillator frequency would allow a sufficiently low detection threshold to be set to differentiate between the signal changes induced at both pads by a human touch opposite a single pad. At 800 kHz, the impedance of the glass drops to 200 kΩ or lower giving a ratio of a greater than 5 to 1 impedance difference between the paths to ground of the touched pad 57 and adjacent pads 59. In fact, the impedance ratio may exceed 10 to 1, as illustrated in the calculation below. This allows the detection threshold for the touched pad to be set well below that of an adjacent pad resulting in a much lower incidence of inadvertent actuation of adjacent touch pads to that of the touched pad. Ideally, the frequency of operation would be kept at the 800 kHz of the preferred embodiment or even higher. However, as noted earlier, higher frequency operation forces the use of more expensive components and designs. For applications where thermal drift</p>

`183 Patent Claim Language	`183 Patent Support
	<p>and electronic noise levels are low, operation at or near 100 kHz may be possible. However, at 10 kHz and below, the impedance of the glass becomes much greater than that of likely water bridges between pads resulting in adjacent pads being effected as much by a touch as the touched pad itself. Although the preferred frequency is at or above 100 kHz, and more preferably at or above 800 kHz, it is conceivable that frequencies as low as 50 kHz could be used provided the frequency creates a difference in the impedance paths of adjacent pads that is sufficient enough to accurately distinguish between an intended touch and the touch of an adjacent pad. Use of frequencies as low as 50 kHz may also be possible depending upon the type of glass or covering or the thickness thereof used for the touch pad. Col. 10:60 – Col. 11:27.</p> <p>The `183 Patent discloses “As will be apparent to those skilled in the art, the values of the resistors and capacitors utilized in oscillator 200 may be varied from those disclosed above to provide for different oscillator output frequencies. As discussed above, however, oscillator 200 is preferably constructed so as to output a square wave having a frequency of 50 kHz or greater, and more preferably, of 800 kHz or greater. Col. 14:22-28.</p> <p>The `183 Patent disclosed “The combination of oscillator voltage, frequency and transistor gain bandwidth product that is used will necessarily vary with the cost, safety and reliability requirements of a given application.” Col. 14:65 – Col. 15:1.</p>

DD. New Claim 67

`183 Patent Claim Language	`183 Patent Support
<p>67. The capacitive responsive electronic switching circuit as defined in claim 111, wherein each signal output frequency selectively provided to each</p>	<p>See Figure 11.</p> <p>The `183 Patent discloses “The touch detection circuit of the present invention features operation</p>

`183 Patent Claim Language	`183 Patent Support
<p>row of the closely spaced array of input touch terminals of the keypad is selected from a plurality of Hertz values.</p>	<p>at frequencies at or above 50 kHz and preferably at or above 800 kHz to minimize the effects of surface contamination from materials such a [sic] skin oils and water. Col. 5:49-53.</p> <p>The `183 Patent discloses “Conversely, at 100 kHz, the glass impedance drops to approximately 1 MΩ resulting in the impedance of the path to ground for pad 59 being twice that of the touched pad 57. For cases where background noise and temperature drifts are comparatively small, a 100 kHz oscillator frequency would allow a sufficiently low detection threshold to be set to differentiate between the signal changes induced at both pads by a human touch opposite a single pad. At 800 kHz, the impedance of the glass drops to 200 kΩ or lower giving a ratio of a greater than 5 to 1 impedance difference between the paths to ground of the touched pad 57 and adjacent pads 59. In fact, the impedance ratio may exceed 10 to 1, as illustrated in the calculation below. This allows the detection threshold for the touched pad to be set well below that of an adjacent pad resulting in a much lower incidence of inadvertent actuation of adjacent touch pads to that of the touched pad. Ideally, the frequency of operation would be kept at the 800 kHz of the preferred embodiment or even higher. However, as noted earlier, higher frequency operation forces the use of more expensive components and designs. For applications where thermal drift and electronic noise levels are low, operation at or near 100 kHz may be possible. However, at 10 kHz and below, the impedance of the glass becomes much greater than that of likely water bridges between pads resulting in adjacent pads being effected as much by a touch as the touched pad itself. Although the preferred frequency is at or above 100 kHz, and more preferably at or above 800 kHz, it is conceivable that frequencies as low as 50 kHz could be used provided the frequency creates a difference in the impedance paths of adjacent pads that is sufficient enough</p>

`183 Patent Claim Language	`183 Patent Support
	<p>to accurately distinguish between an intended touch and the touch of an adjacent pad. Use of frequencies as low as 50 kHz may also be possible depending upon the type of glass or covering or the thickness thereof used for the touch pad. Col. 10:60 – Col. 11:27.</p> <p>The `183 Patent discloses “As will be apparent to those skilled in the art, the values of the resistors and capacitors utilized in oscillator 200 may be varied from those disclosed above to provide for different oscillator output frequencies. As discussed above, however, oscillator 200 is preferably constructed so as to output a square wave having a frequency of 50 kHz or greater, and more preferably, of 800 kHz or greater. Col. 14:22-28.</p> <p>The `183 Patent disclosed “The combination of oscillator voltage, frequency and transistor gain bandwidth product that is used will necessarily vary with the cost, safety and reliability requirements of a given application.” Col. 14:65 – Col. 15:1.</p>

EE. New Claim 68

`183 Patent Claim Language	`183 Patent Support
<p>68. The capacitive responsive electronic switching circuit as defined in claim 67, wherein the plurality of Hertz values comprises Hertz values greater than 50 kHz.</p>	<p>See Figure 11.</p> <p>The `183 Patent discloses “The touch detection circuit of the present invention features operation at frequencies at or above 50 kHz and preferably at or above 800 kHz to minimize the effects of surface contamination from materials such a [sic] skin oils and water. Col. 5:49-53.</p> <p>The `183 Patent discloses “Conversely, at 100 kHz, the glass impedance drops to approximately 1 MΩ resulting in the impedance of the path to ground for pad 59 being twice that of the touched pad 57. For cases where background noise and temperature drifts are comparatively small, a 100 kHz oscillator</p>

`183 Patent Claim Language	`183 Patent Support
	<p>frequency would allow a sufficiently low detection threshold to be set to differentiate between the signal changes induced at both pads by a human touch opposite a single pad. At 800 kHz, the impedance of the glass drops to 200 kΩ or lower giving a ratio of a greater than 5 to 1 impedance difference between the paths to ground of the touched pad 57 and adjacent pads 59. In fact, the impedance ratio may exceed 10 to 1, as illustrated in the calculation below. This allows the detection threshold for the touched pad to be set well below that of an adjacent pad resulting in a much lower incidence of inadvertent actuation of adjacent touch pads to that of the touched pad. Ideally, the frequency of operation would be kept at the 800 kHz of the preferred embodiment or even higher. However, as noted earlier, higher frequency operation forces the use of more expensive components and designs. For applications where thermal drift and electronic noise levels are low, operation at or near 100 kHz may be possible. However, at 10 kHz and below, the impedance of the glass becomes much greater than that of likely water bridges between pads resulting in adjacent pads being effected as much by a touch as the touched pad itself. Although the preferred frequency is at or above 100 kHz, and more preferably at or above 800 kHz, it is conceivable that frequencies as low as 50 kHz could be used provided the frequency creates a difference in the impedance paths of adjacent pads that is sufficient enough to accurately distinguish between an intended touch and the touch of an adjacent pad. Use of frequencies as low as 50 kHz may also be possible depending upon the type of glass or covering or the thickness thereof used for the touch pad. Col. 10:60 – Col. 11:27.</p> <p>The `183 Patent discloses “As will be apparent to those skilled in the art, the values of the resistors and capacitors utilized in oscillator 200 may be varied from those disclosed above to provide for different oscillator output</p>

`183 Patent Claim Language	`183 Patent Support
	<p>frequencies. As discussed above, however, oscillator 200 is preferably constructed so as to output a square wave having a frequency of 50 kHz or greater, and more preferably, of 800 kHz or greater. Col. 14:22-28.</p> <p>The `183 Patent disclosed “The combination of oscillator voltage, frequency and transistor gain bandwidth product that is used will necessarily vary with the cost, safety and reliability requirements of a given application.” Col. 14:65 – Col. 15:1.</p>

FF. New Claim 69

`183 Patent Claim Language	`183 Patent Support
<p>69. The capacitive responsive electronic switching circuit as defined in claim 67, wherein the plurality of Hertz values comprises Hertz values greater than 100 kHz.</p>	<p>See Figure 11.</p> <p>The `183 Patent discloses “The touch detection circuit of the present invention features operation at frequencies at or above 50 kHz and preferably at or above 800 kHz to minimize the effects of surface contamination from materials such a [sic] skin oils and water. Col. 5:49-53.</p> <p>The `183 Patent discloses “Conversely, at 100 kHz, the glass impedance drops to approximately 1 MΩ resulting in the impedance of the path to ground for pad 59 being twice that of the touched pad 57. For cases where background noise and temperature drifts are comparatively small, a 100 kHz oscillator frequency would allow a sufficiently low detection threshold to be set to differentiate between the signal changes induced at both pads by a human touch opposite a single pad. At 800 kHz, the impedance of the glass drops to 200 kΩ or lower giving a ratio of a greater than 5 to 1 impedance difference between the paths to ground of the touched pad 57 and adjacent pads 59. In fact, the impedance ratio may exceed 10 to 1, as illustrated in the calculation below. This allows the detection threshold for the touched pad to be set well below that of an adjacent pad</p>

`183 Patent Claim Language	`183 Patent Support
	<p>resulting in a much lower incidence of inadvertent actuation of adjacent touch pads to that of the touched pad. Ideally, the frequency of operation would be kept at the 800 kHz of the preferred embodiment or even higher. However, as noted earlier, higher frequency operation forces the use of more expensive components and designs. For applications where thermal drift and electronic noise levels are low, operation at or near 100 kHz may be possible. However, at 10 kHz and below, the impedance of the glass becomes much greater than that of likely water bridges between pads resulting in adjacent pads being effected as much by a touch as the touched pad itself. Although the preferred frequency is at or above 100 kHz, and more preferably at or above 800 kHz, it is conceivable that frequencies as low as 50 kHz could be used provided the frequency creates a difference in the impedance paths of adjacent pads that is sufficient enough to accurately distinguish between an intended touch and the touch of an adjacent pad. Use of frequencies as low as 50 kHz may also be possible depending upon the type of glass or covering or the thickness thereof used for the touch pad. Col. 10:60 – Col. 11:27.</p> <p>The `183 Patent discloses “As will be apparent to those skilled in the art, the values of the resistors and capacitors utilized in oscillator 200 may be varied from those disclosed above to provide for different oscillator output frequencies. As discussed above, however, oscillator 200 is preferably constructed so as to output a square wave having a frequency of 50 kHz or greater, and more preferably, of 800 kHz or greater. Col. 14:22-28.</p> <p>The `183 Patent disclosed “The combination of oscillator voltage, frequency and transistor gain bandwidth product that is used will necessarily vary with the cost, safety and reliability requirements of a given application.” Col. 14:65 – Col. 15:1.</p>

GG. New Claim 70

`183 Patent Claim Language	`183 Patent Support
<p>70. The capacitive responsive electronic switching circuit as defined in claim 67, wherein the plurality of Hertz values comprises Hertz values greater than 800 kHz.</p>	<p>See Fig. 11.</p> <p>The `183 Patent discloses “The touch detection circuit of the present invention features operation at frequencies at or above 50 kHz and preferably at or above 800 kHz to minimize the effects of surface contamination from materials such a [sic] skin oils and water. Col. 5:49-53.</p> <p>The `183 Patent discloses “At 800 kHz, the impedance of the glass drops to 200 kΩ or lower giving a ratio of a greater than 5 to 1 impedance difference between the paths to ground of the touched pad 57 and adjacent pads 59. In fact, the impedance ratio may exceed 10 to 1, as illustrated in the calculation below. This allows the detection threshold for the touched pad to be set well below that of an adjacent pad resulting in a much lower incidence of inadvertent actuation of adjacent touch pads to that of the touched pad. Ideally, the frequency of operation would be kept at the 800 kHz of the preferred embodiment or even higher. However, as noted earlier, higher frequency operation forces the use of more expensive components and designs. For applications where thermal drift and electronic noise levels are low, operation at or near 100 kHz may be possible. However, at 10 kHz and below, the impedance of the glass becomes much greater than that of likely water bridges between pads resulting in adjacent pads being effected as much by a touch as the touched pad itself. Although the preferred frequency is at or above 100 kHz, and more preferably at or above 800 kHz, it is conceivable that frequencies as low as 50 kHz could be used provided the frequency creates a difference in the impedance paths of adjacent pads that is sufficient enough to accurately distinguish between an intended touch and the touch of an adjacent pad. Use of frequencies as low as 50 kHz may also be possible depending upon the type of glass or</p>

`183 Patent Claim Language	`183 Patent Support
	<p>covering or the thickness thereof used for the touch pad. Col. 11:1-27.</p> <p>The `183 Patent discloses “As will be apparent to those skilled in the art, the values of the resistors and capacitors utilized in oscillator 200 may be varied from those disclosed above to provide for different oscillator output frequencies. As discussed above, however, oscillator 200 is preferably constructed so as to output a square wave having a frequency of 50 kHz or greater, and more preferably, of 800 kHz or greater. Col. 14:22-28.</p> <p>The `183 Patent disclosed “The combination of oscillator voltage, frequency and transistor gain bandwidth product that is used will necessarily vary with the cost, safety and reliability requirements of a given application.” Col. 14:65 – Col. 15:1.</p>

HH. New Claim 71

`183 Patent Claim Language	`183 Patent Support
<p>71. The capacitive responsive electronic switching circuit as defined in claim 111, wherein the detector circuit is configured to inhibit the control output signal unless the operator is proximal or touches said second touch terminal after the operator is proximal or touches said first touch terminal.</p>	<p>See Figures 19, 20A-C; and Claims 28 and 35.</p> <p>The `183 Patent discloses “In another embodiment a method to prevent inadvertent so actuations is to require a multi-step process. Referring to FIG. 19, a device is shown having a first palm button 2201, a second palm button 2202, and an indicator light 2205. Palm button 2201 has to be activated first and then button 2202 has to be activated within a 2 second time window before a desired actuation can occur.” Col. 22:49-55.</p> <p>The `183 Patent discloses “In a variation of the multi-step process, two touch plates within a housing (one vertical and one horizontal) are used to provide a two-step turn-on. Referring to FIGS. 20A-C, the first step to actuate the output relay 2310, is initiated when the operator inserts his hands and touches the vertical touch sensor</p>

`183 Patent Claim Language	`183 Patent Support
	<p>2301 with the dorsal side of the hands. A yellow LED 2304 on top of the device show the successful completion of the first step. The second step is to flip the hand over and touch the horizontal touch sensor 2302 with the palmar side of the hand. A red LED 2305 on top of the device shows the completion of the two step turn-on and activation of output relay 2310. The flipping action of the hand in the second step causes the forearm muscles to flex, thereby reducing stiffness and fatigue. Also, the hands, and arms can rest on the run bar until the machine cycle is complete. The second step of the two-step turn-on must occur within some predetermined time (for example 2 seconds) after the release of vertical touch sensor or the first step must be repeated.” Col. 23:19-36.</p>

II. New Claim 72

For ease of analysis, new independent claim 72 is shown below with pseudo-amendments illustrating the differences between new claim 72 and claim 27 of the `183 Patent following the first reexamination proceeding.

`183 Patent Claim Language	`183 Patent Support
<p>72. A capacitive responsive electronic switching circuit for a controlled keypad device comprising:</p>	<p>See Claim 27.</p>
<p>an oscillator providing a periodic output signal having a predefined frequency;</p>	<p>See Claim 27.</p>
<p>a microcontroller using the periodic output signal from the oscillator, the microcontroller selectively providing signal output frequencies <u>directly</u> to a closely spaced array of input touch terminals of a keypad, the input touch terminals comprising first and second input touch terminals;</p>	<p>See Figures 4, 11; and Claims 8, 12, 16.</p> <p>The `183 Patent discloses “The touch detection circuit of the present invention features operation at frequencies at or above 50 kHz and preferably at or above 800 kHz to minimize the effects of surface contamination from materials such a [sic] skin oils and water. It also offers improvements in detection sensitivity that allow close control of the degree of proximity (ideally</p>

`183 Patent Claim Language	`183 Patent Support
	<p>very close proximity) that is required for actuation and to enable employment of a multiplicity of small sized touch terminals in a physically close array such as a keyboard.” Col. 5:49-57.</p> <p>The `183 Patent discloses “In a first preferred embodiment the circuit offers enhanced detection sensitivity to allow reliable operation with small (finger size) touch pads.” Col. 6:1-3.</p> <p>The `183 Patent discloses “Although the preferred frequency is at or above 100 kHz, and more preferably at or above 800 kHz, it is conceivable that frequencies as low as 50 kHz could be used provided the frequency creates a difference in the impedance paths of adjacent pads that is sufficient enough to accurately distinguish between an intended touch and the touch of an adjacent pad. Use of frequencies as low as 50 kHz may also be possible depending upon the type of glass or covering or the thickness thereof used for the touch pad.” Col. 11:19-27.</p> <p>The `183 Patent discloses “Upon being powered by voltage regulator 100, oscillator 200 generates a square wave with a frequency of 50 kHz, and preferably greater than 800 kHz, and having an amplitude of 26 V peak. The square wave generated by oscillator 200 is supplied via line 201 to a floating common generator 300, a touch pad shield plate 460, a touch circuit 400, and a microcontroller 500. Oscillator 200 is described below with reference to FIG. 6. Floating common generator 300 receives the 26 V peak square wave from oscillator 200 and outputs a regulated floating common that is 5 volts below the square wave output from oscillator 200 and has the same phase and frequency as the received square wave. This floating common output is supplied to touch circuit 400 and microcontroller 500 via line 301 such that the output square wave from oscillator</p>

`183 Patent Claim Language	`183 Patent Support
	<p>200 and floating common output from floating common generator 300 provide power to touch circuit 400 and microcontroller 500. Details of floating common generator 300 are discussed below with reference to FIG. 7.</p> <p>Touch circuit 400 senses capacitance from a touch pad 450 via line 451 and outputs a signal to microcontroller 500 via line 401 upon detecting a capacitance to ground at touch pad 450 that exceeds a threshold value. The details of touch circuit 400 are described below with reference to FIG. 8.</p> <p>Upon receiving an indication from touch circuit 400 that a sufficient capacitance to ground (typically at least 20 pF) is present at touch pad 450, microcontroller 500 outputs a signal to a load-controlling microcontroller 600 via line 501, which is preferably a two way optical coupling bus.” Col. 12:6-33.</p> <p>The `183 Patent discloses “As will be apparent to those skilled in the art, the values of the resistors and capacitors utilized in oscillator 200 may be varied from those disclosed above to provide for different oscillator output frequencies.” Col. 14:22-25.</p> <p>The `183 Patent discloses “A multiple touch pad circuit constructed in accordance with the second embodiment is shown in FIG. 11. In the second embodiment of FIG. 11, components similar to those in the first embodiment in FIG. 4 are designated with the same references numerals and will not be discussed in detail.</p> <p>The multiple touch pad circuit is a variation of the first embodiment in that it includes an array of touch circuits designated as 900₁ through 900_{nm}, which, as shown, include both the touch circuit 400 shown in FIGS. 4 and 8 and the input touch terminal pad 451 (FIG. 4).</p> <p>Microcontroller 500 selects each row of the touch circuits 900₁ to 900_{nm} by providing the signal from oscillator 200 to selected rows of touch circuits. In this manner, microcontroller</p>

`183 Patent Claim Language	`183 Patent Support
	<p>500 can sequentially activate the touch circuit rows and associate the received inputs from the columns of the array with the activated touch circuit(s). To keep the path length 451 between the touch pad 450 and the base to the detection transistor 410 to a minimum, the detection circuits 900 are physically located directly beneath the touch pads. To simplify assembly, a flexible circuit board such as vended by Sheldahl, Inc. or Circuit Etching Technics, Inc. can be used for this purpose. Ideally, the printed circuit will be fixed directly against the surface (typically glass) bearing the conductive touch pads to eliminate air gaps and the need for conductive foam pads and spring contacts which were used to fill air gaps.” Col. 18:34-59.</p>
<p>the first and second input touch terminals defining areas for an operator to provide an input by proximity and touch; and</p>	<p>See Claim 27.</p>
<p>a detector circuit coupled to said oscillator for receiving said periodic output signal from said oscillator, and coupled to said first and second touch terminals, said detector circuit being responsive to signals from said oscillator via said microcontroller and a presence of an operator's body capacitance to ground coupled to said first and second touch terminals when proximal or touched by the operator to provide a control output signal for actuation of the controlled keypad device, said detector circuit being configured to generate said control output signal when the operator is proximal or touches said second touch terminal after the operator is proximal or touches said first touch terminal.</p>	<p>See Claim 27.</p>

JJ. New Claim 73

`183 Patent Claim Language	`183 Patent Support
<p>73. The capacitive responsive</p>	<p>See Figure 11.</p>

`183 Patent Claim Language	`183 Patent Support
<p>electronic switching circuit as defined in claim 72, wherein the signal output frequencies have a same Hertz value.</p>	<p>The `183 Patent discloses “The touch detection circuit of the present invention features operation at frequencies at or above 50 kHz and preferably at or above 800 kHz to minimize the effects of surface contamination from materials such a [sic] skin oils and water. Col. 5:49-53.</p> <p>The `183 Patent discloses “Conversely, at 100 kHz, the glass impedance drops to approximately 1 MΩ resulting in the impedance of the path to ground for pad 59 being twice that of the touched pad 57. For cases where background noise and temperature drifts are comparatively small, a 100 kHz oscillator frequency would allow a sufficiently low detection threshold to be set to differentiate between the signal changes induced at both pads by a human touch opposite a single pad. At 800 kHz, the impedance of the glass drops to 200 kΩ or lower giving a ratio of a greater than 5 to 1 impedance difference between the paths to ground of the touched pad 57 and adjacent pads 59. In fact, the impedance ratio may exceed 10 to 1, as illustrated in the calculation below. This allows the detection threshold for the touched pad to be set well below that of an adjacent pad resulting in a much lower incidence of inadvertent actuation of adjacent touch pads to that of the touched pad. Ideally, the frequency of operation would be kept at the 800 kHz of the preferred embodiment or even higher. However, as noted earlier, higher frequency operation forces the use of more expensive components and designs. For applications where thermal drift and electronic noise levels are low, operation at or near 100 kHz may be possible. However, at 10 kHz and below, the impedance of the glass becomes much greater than that of likely water bridges between pads resulting in adjacent pads being effected as much by a touch as the touched pad itself. Although the preferred frequency is at or above 100 kHz, and more preferably at or above 800 kHz, it is conceivable that frequencies</p>

`183 Patent Claim Language	`183 Patent Support
	<p>as low as 50 kHz could be used provided the frequency creates a difference in the impedance paths of adjacent pads that is sufficient enough to accurately distinguish between an intended touch and the touch of an adjacent pad. Use of frequencies as low as 50 kHz may also be possible depending upon the type of glass or covering or the thickness thereof used for the touch pad. Col. 10:60 – Col. 11:27.</p> <p>The `183 Patent discloses “As will be apparent to those skilled in the art, the values of the resistors and capacitors utilized in oscillator 200 may be varied from those disclosed above to provide for different oscillator output frequencies. As discussed above, however, oscillator 200 is preferably constructed so as to output a square wave having a frequency of 50 kHz or greater, and more preferably, of 800 kHz or greater. Col. 14:22-28.</p> <p>The `183 Patent disclosed “The combination of oscillator voltage, frequency and transistor gain bandwidth product that is used will necessarily vary with the cost, safety and reliability requirements of a given application.” Col. 14:65 – Col. 15:1.</p>

KK. New Claim 74

`183 Patent Claim Language	`183 Patent Support
<p>74. The capacitive responsive electronic switching circuit as defined in claim 72, wherein each signal output frequency is selected from a plurality of Hertz values.</p>	<p>See Figure 11.</p> <p>The `183 Patent discloses “The touch detection circuit of the present invention features operation at frequencies at or above 50 kHz and preferably at or above 800 kHz to minimize the effects of surface contamination from materials such a [sic] skin oils and water. Col. 5:49-53.</p> <p>The `183 Patent discloses “Conversely, at 100 kHz, the glass impedance drops to approximately 1 MΩ resulting in the impedance of the path to ground for pad 59 being twice that</p>

`183 Patent Claim Language	`183 Patent Support
	<p>of the touched pad 57. For cases where background noise and temperature drifts are comparatively small, a 100 kHz oscillator frequency would allow a sufficiently low detection threshold to be set to differentiate between the signal changes induced at both pads by a human touch opposite a single pad. At 800 kHz, the impedance of the glass drops to 200 kΩ or lower giving a ratio of a greater than 5 to 1 impedance difference between the paths to ground of the touched pad 57 and adjacent pads 59. In fact, the impedance ratio may exceed 10 to 1, as illustrated in the calculation below. This allows the detection threshold for the touched pad to be set well below that of an adjacent pad resulting in a much lower incidence of inadvertent actuation of adjacent touch pads to that of the touched pad. Ideally, the frequency of operation would be kept at the 800 kHz of the preferred embodiment or even higher. However, as noted earlier, higher frequency operation forces the use of more expensive components and designs. For applications where thermal drift and electronic noise levels are low, operation at or near 100 kHz may be possible. However, at 10 kHz and below, the impedance of the glass becomes much greater than that of likely water bridges between pads resulting in adjacent pads being effected as much by a touch as the touched pad itself. Although the preferred frequency is at or above 100 kHz, and more preferably at or above 800 kHz, it is conceivable that frequencies as low as 50 kHz could be used provided the frequency creates a difference in the impedance paths of adjacent pads that is sufficient enough to accurately distinguish between an intended touch and the touch of an adjacent pad. Use of frequencies as low as 50 kHz may also be possible depending upon the type of glass or covering or the thickness thereof used for the touch pad. Col. 10:60 – Col. 11:27.</p> <p>The `183 Patent discloses “As will be apparent to those skilled in the art, the values of the</p>

`183 Patent Claim Language	`183 Patent Support
	<p>resistors and capacitors utilized in oscillator 200 may be varied from those disclosed above to provide for different oscillator output frequencies. As discussed above, however, oscillator 200 is preferably constructed so as to output a square wave having a frequency of 50 kHz or greater, and more preferably, of 800 kHz or greater. Col. 14:22-28.</p> <p>The `183 Patent disclosed “The combination of oscillator voltage, frequency and transistor gain bandwidth product that is used will necessarily vary with the cost, safety and reliability requirements of a given application.” Col. 14:65 – Col. 15:1.</p>

LL. New Claim 75

`183 Patent Claim Language	`183 Patent Support
<p>75. The capacitive responsive electronic switching circuit as defined in claim 74, wherein the plurality of Hertz values comprises Hertz values greater than 50 kHz.</p>	<p>See Figure 11.</p> <p>The `183 Patent discloses “The touch detection circuit of the present invention features operation at frequencies at or above 50 kHz and preferably at or above 800 kHz to minimize the effects of surface contamination from materials such a [sic] skin oils and water. Col. 5:49-53.</p> <p>The `183 Patent discloses “Conversely, at 100 kHz, the glass impedance drops to approximately 1 MΩ resulting in the impedance of the path to ground for pad 59 being twice that of the touched pad 57. For cases where background noise and temperature drifts are comparatively small, a 100 kHz oscillator frequency would allow a sufficiently low detection threshold to be set to differentiate between the signal changes induced at both pads by a human touch opposite a single pad. At 800 kHz, the impedance of the glass drops to 200 kΩ or lower giving a ratio of a greater than 5 to 1 impedance difference between the paths to ground of the touched pad 57 and adjacent pads 59. In fact, the impedance ratio may exceed 10</p>

`183 Patent Claim Language	`183 Patent Support
	<p>to 1, as illustrated in the calculation below. This allows the detection threshold for the touched pad to be set well below that of an adjacent pad resulting in a much lower incidence of inadvertent actuation of adjacent touch pads to that of the touched pad. Ideally, the frequency of operation would be kept at the 800 kHz of the preferred embodiment or even higher. However, as noted earlier, higher frequency operation forces the use of more expensive components and designs. For applications where thermal drift and electronic noise levels are low, operation at or near 100 kHz may be possible. However, at 10 kHz and below, the impedance of the glass becomes much greater than that of likely water bridges between pads resulting in adjacent pads being effected as much by a touch as the touched pad itself. Although the preferred frequency is at or above 100 kHz, and more preferably at or above 800 kHz, it is conceivable that frequencies as low as 50 kHz could be used provided the frequency creates a difference in the impedance paths of adjacent pads that is sufficient enough to accurately distinguish between an intended touch and the touch of an adjacent pad. Use of frequencies as low as 50 kHz may also be possible depending upon the type of glass or covering or the thickness thereof used for the touch pad. Col. 10:60 – Col. 11:27.</p> <p>The `183 Patent discloses “As will be apparent to those skilled in the art, the values of the resistors and capacitors utilized in oscillator 200 may be varied from those disclosed above to provide for different oscillator output frequencies. As discussed above, however, oscillator 200 is preferably constructed so as to output a square wave having a frequency of 50 kHz or greater, and more preferably, of 800 kHz or greater. Col. 14:22-28.</p> <p>The `183 Patent disclosed “The combination of oscillator voltage, frequency and transistor gain bandwidth product that is used will necessarily</p>

`183 Patent Claim Language	`183 Patent Support
	vary with the cost, safety and reliability requirements of a given application.” Col. 14:65 – Col. 15:1.

MM. New Claim 76

`183 Patent Claim Language	`183 Patent Support
<p>76. The capacitive responsive electronic switching circuit as defined in claim 74, wherein the plurality of Hertz values comprises Hertz values greater than 100 kHz.</p>	<p>See Figure 11.</p> <p>The `183 Patent discloses “The touch detection circuit of the present invention features operation at frequencies at or above 50 kHz and preferably at or above 800 kHz to minimize the effects of surface contamination from materials such a [sic] skin oils and water. Col. 5:49-53.</p> <p>The `183 Patent discloses “Conversely, at 100 kHz, the glass impedance drops to approximately 1 MΩ resulting in the impedance of the path to ground for pad 59 being twice that of the touched pad 57. For cases where background noise and temperature drifts are comparatively small, a 100 kHz oscillator frequency would allow a sufficiently low detection threshold to be set to differentiate between the signal changes induced at both pads by a human touch opposite a single pad. At 800 kHz, the impedance of the glass drops to 200 kΩ or lower giving a ratio of a greater than 5 to 1 impedance difference between the paths to ground of the touched pad 57 and adjacent pads 59. In fact, the impedance ratio may exceed 10 to 1, as illustrated in the calculation below. This allows the detection threshold for the touched pad to be set well below that of an adjacent pad resulting in a much lower incidence of inadvertent actuation of adjacent touch pads to that of the touched pad. Ideally, the frequency of operation would be kept at the 800 kHz of the preferred embodiment or even higher. However, as noted earlier, higher frequency operation forces the use of more expensive components and designs. For applications where thermal drift and electronic noise levels are low, operation at</p>

`183 Patent Claim Language	`183 Patent Support
	<p>or near 100 kHz may be possible. However, at 10 kHz and below, the impedance of the glass becomes much greater than that of likely water bridges between pads resulting in adjacent pads being effected as much by a touch as the touched pad itself. Although the preferred frequency is at or above 100 kHz, and more preferably at or above 800 kHz, it is conceivable that frequencies as low as 50 kHz could be used provided the frequency creates a difference in the impedance paths of adjacent pads that is sufficient enough to accurately distinguish between an intended touch and the touch of an adjacent pad. Use of frequencies as low as 50 kHz may also be possible depending upon the type of glass or covering or the thickness thereof used for the touch pad. Col. 10:60 – Col. 11:27.</p> <p>The `183 Patent discloses “As will be apparent to those skilled in the art, the values of the resistors and capacitors utilized in oscillator 200 may be varied from those disclosed above to provide for different oscillator output frequencies. As discussed above, however, oscillator 200 is preferably constructed so as to output a square wave having a frequency of 50 kHz or greater, and more preferably, of 800 kHz or greater. Col. 14:22-28.</p> <p>The `183 Patent disclosed “The combination of oscillator voltage, frequency and transistor gain bandwidth product that is used will necessarily vary with the cost, safety and reliability requirements of a given application.” Col. 14:65 – Col. 15:1.</p>

NN. New Claim 77

`183 Patent Claim Language	`183 Patent Support
<p>77. The capacitive responsive electronic switching circuit as defined in claim 74, wherein the plurality of Hertz values comprises Hertz values greater</p>	<p>See Fig. 11.</p> <p>The `183 Patent discloses “The touch detection circuit of the present invention features operation at frequencies at or above 50 kHz and preferably</p>

`183 Patent Claim Language	`183 Patent Support
<p>than 800 kHz.</p>	<p>at or above 800 kHz to minimize the effects of surface contamination from materials such a [sic] skin oils and water. Col. 5:49-53.</p> <p>The `183 Patent discloses “At 800 kHz, the impedance of the glass drops to 200 kΩ or lower giving a ratio of a greater than 5 to 1 impedance difference between the paths to ground of the touched pad 57 and adjacent pads 59. In fact, the impedance ratio may exceed 10 to 1, as illustrated in the calculation below. This allows the detection threshold for the touched pad to be set well below that of an adjacent pad resulting in a much lower incidence of inadvertent actuation of adjacent touch pads to that of the touched pad. Ideally, the frequency of operation would be kept at the 800 kHz of the preferred embodiment or even higher. However, as noted earlier, higher frequency operation forces the use of more expensive components and designs. For applications where thermal drift and electronic noise levels are low, operation at or near 100 kHz may be possible. However, at 10 kHz and below, the impedance of the glass becomes much greater than that of likely water bridges between pads resulting in adjacent pads being effected as much by a touch as the touched pad itself. Although the preferred frequency is at or above 100 kHz, and more preferably at or above 800 kHz, it is conceivable that frequencies as low as 50 kHz could be used provided the frequency creates a difference in the impedance paths of adjacent pads that is sufficient enough to accurately distinguish between an intended touch and the touch of an adjacent pad. Use of frequencies as low as 50 kHz may also be possible depending upon the type of glass or covering or the thickness thereof used for the touch pad. Col. 11:1-27.</p> <p>The `183 Patent discloses “As will be apparent to those skilled in the art, the values of the resistors and capacitors utilized in oscillator 200 may be varied from those disclosed above to</p>

`183 Patent Claim Language	`183 Patent Support
	<p>provide for different oscillator output frequencies. As discussed above, however, oscillator 200 is preferably constructed so as to output a square wave having a frequency of 50 kHz or greater, and more preferably, of 800 kHz or greater. Col. 14:22-28.</p> <p>The `183 Patent disclosed “The combination of oscillator voltage, frequency and transistor gain bandwidth product that is used will necessarily vary with the cost, safety and reliability requirements of a given application.” Col. 14:65 – Col. 15:1.</p>

OO. New Claim 78

For ease of analysis, new dependent claim 78 is shown below with pseudo-amendments illustrating the differences between new claim 78 and claim 28 of the `183 Patent following the first reexamination proceeding.

`183 Patent Claim Language	`183 Patent Support
<p>78. The capacitive responsive electronic switching circuit as defined in claim 72, wherein said detector circuit generates <u>is configured to generate</u> said control <u>output</u> signal only when the operator is proximal or touches said second touch terminal within a predetermined time period after the operator is proximal or touches said first touch terminal.</p>	<p>See Claims 27 and 28.</p>

PP. New Claim 79

For ease of analysis, new dependent claim 79 is shown below with pseudo-amendments illustrating the differences between new claim 79 and claim 36 of the `183 Patent following the first reexamination proceeding.

`183 Patent Claim Language	`183 Patent Support
<p>79. The capacitive responsive</p>	<p>See Claims 32 and 36.</p>

`183 Patent Claim Language	`183 Patent Support
<p>electronic switching circuit as defined in claim 72, and further including <u>comprising</u> an indicator for indicating when said the <u>the</u> detector circuit determines <u>has determined</u> that the operator is proximal or touches said second touch terminal.</p>	<p>The `183 Patent discloses “The microprocessor also allows the use of visual indicators such as LEDs or annunciators such as a bell or tone generator to confirm the actuation of a given touch switch or switches. This is particularly useful in cases where a sequence of actuations is required before an action occurs. The feedback to the operator provided by a visual or audio indicator activated by the microprocessor in response to intermediate touches in a required sequence can minimize time lost and/or frustration on the part of the operator due to failed actuations from partial touches or wrong actuations from touching the wrong pad in a given required sequence or combination of touches.” Col. 6:31-42.</p> <p>The `183 Patent discloses “A further option is to provide one or more LEDs 2205 or audible annunciators for visual or audible feedback to the operator. Specifically, in FIG. 19 the LED 2205 will come on when button 2201 has been successfully activated to cue the operator that it is time to move to button 2202. Where required a second LED with a different color than the first (yellow for the first LED and red for the second) can be provided to provide visual confirmation that the second button 2202 has been activated or that the required combination of the two buttons has been activated. Two different audible tone or sound generators could also be used in lieu of the LEDs to provide feedback to the operator.” Col. 23:1-12.</p> <p>The `183 Patent discloses “A red LED 2305 on top of the device shows the completion of the two step turn-on and activation of output relay 2310.” Col. 23:28-30.</p>

QQ. New Claim 80

`183 Patent Claim Language	`183 Patent Support
80. The capacitive responsive	See Figures 19, 20A-C; and Claims 28 and 35.

`183 Patent Claim Language	`183 Patent Support
<p>electronic switching circuit as defined in claim 72, wherein the detector circuit is configured to inhibit the control output signal unless the operator is proximal or touches said second touch terminal after the operator is proximal or touches said first touch terminal.</p>	<p>The `183 Patent discloses “In another embodiment a method to prevent inadvertent so actuations is to require a multi-step process. Referring to FIG. 19, a device is shown having a first palm button 2201, a second palm button 2202, and an indicator light 2205. Palm button 2201 has to be activated first and then button 2202 has to be activated within a 2 second time window before a desired actuation can occur.” Col. 22:49-55.</p> <p>The `183 Patent discloses “In a variation of the multi-step process, two touch plates within a housing (one vertical and one horizontal) are used to provide a two-step turn-on. Referring to FIGS. 20A-C, the first step to actuate the output relay 2310, is initiated when the operator inserts his hands and touches the vertical touch sensor 2301 with the dorsal side of the hands. A yellow LED 2304 on top of the device show the successful completion of the first step. The second step is to flip the hand over and touch the horizontal touch sensor 2302 with the palmar side of the hand. A red LED 2305 on top of the device shows the completion of the two step turn-on and activation of output relay 2310. The flipping action of the hand in the second step causes the forearm muscles to flex, thereby reducing stiffness and fatigue. Also, the hands, and arms can rest on the run bar until the machine cycle is complete. The second step of the two-step turn-on must occur within some predetermined time (for example 2 seconds) after the release of vertical touch sensor or the first step must be repeated.” Col. 23:19-36.</p>

RR. New Claim 81

`183 Patent Claim Language	`183 Patent Support
<p>81. The capacitive responsive electronic switching circuit as defined in claim 72, wherein a peak voltage of the signal output frequencies is greater than a</p>	<p>See Figures 4, 5; Claims 27 and 37.</p> <p>The `183 Patent discloses “Having provided a basis for the use of higher frequencies, the basic</p>

`183 Patent Claim Language	`183 Patent Support
<p>supply voltage.</p>	<p>construction of the electronic switching circuit constructed in accordance with a first embodiment of the present invention is now described with reference to FIG. 4. The electronic switching circuit includes a voltage regulator 100 including input lines 101 and 102 for receiving a 24 V AC line voltage and a line 103 for grounding the circuit. Voltage regulator 100 converts the received AC voltage to a DC voltage and supplies a regulated 5 V DC power to an oscillator 200 via lines 104 and 105. Voltage regulator also supplies oscillator 200 with 26 V DC power via line 106. The details of voltage regulator 100 are discussed below with reference to FIG. 5.</p> <p>Upon being powered by voltage regulator 100, oscillator 200 generates a square wave with a frequency of 50 kHz, and preferably greater than 800 kHz, and having an amplitude of 26 V peak. The square wave generated by oscillator 200 is supplied via line 201 to a floating common generator 300, a touch pad shield plate 460, a touch circuit 400, and a microcontroller 500. Oscillator 200 is described below with reference to FIG. 6.” Col. 11:60 – Col. 12:13.</p> <p>The `183 Patent discloses “Microcontroller 500 selects each row of the touch circuits 900₁ to 900_{nm} by providing the signal from oscillator 200 to selected rows of touch circuits. In this manner, microcontroller 500 can sequentially activate the touch circuit rows and associate the received inputs from the columns of the array with the activated touch circuit(s).” Col. 18:43-49.</p> <p>The `183 Patent discloses “A preferred circuit for implementing a voltage regulator 100 is shown in FIG. 5. Voltage regulator 100 preferably includes an AC/DC convertor 110 for generating 29 V to 36 V unregulated DC on line 119. This unregulated DC power is supplied to a 5 V DC regulator 120 and to a 26 V DC regulator 130. AC/DC convertor 110 includes</p>

`183 Patent Claim Language	`183 Patent Support
	<p>diodes 112, 114, 116, and 118, which rectify the supplied 24 V AC power provided on power lines 101 and 102.” Col. 12:50-57; see also Col. 12:57 – Col. 13:31.</p> <p>The `183 Patent discloses “The oscillator circuitry shown in FIG. 6 is very stable over the temperature range of -40° C. to 105° C. The output of the touch switch circuitry drops at a rate of approximately 40 mV/°C. when temperature falls below 0° C. If application requires operation at low temperatures (-40° C.), the following three methods may be used to increase the output of the switch: increase the oscillator’s regulated supply voltage, increase the resistance of resistor 416, and use a higher gain transistor 410. All of these methods would increase sensitivity at high temperatures.” Col. 16:33-41.</p>

SS. New Claim 82

`183 Patent Claim Language	`183 Patent Support
<p>82. The capacitive responsive electronic switching circuit as defined in claim 81, wherein the supply voltage is a battery supply voltage.</p>	<p>The `183 Patent discloses “It will be apparent to those skilled in the art, that various components of voltage regulator 100 may be added or excluded depending upon the source of power available to power the oscillator 200. For example, if the available power is a 110 V AC 60 Hz commercial power line, a transformer may be added to convert the 100 V AC power to 24 V AC. Alternatively, if a DC batter is used, the AC/DC convertor among other components may be eliminated.” Col 13:23-31.</p>

TT. New Claim 83

`183 Patent Claim Language	`183 Patent Support
<p>83. The capacitive responsive electronic switching circuit as defined in claim 81, wherein the supply voltage is a</p>	<p>Figures 4, 5, 11, and 12.</p> <p>The `183 Patent discloses “The electronic switching circuit includes a voltage regulator 100 including input lines 101 and 102 for</p>

`183 Patent Claim Language	`183 Patent Support
voltage regulator supply voltage.	receiving a 24 V AC line voltage and a line 103 for grounding the circuit. Voltage regulator 100 converts the received AC voltage to a DC voltage and supplies a regulated 5 V DC power to an oscillator 200 via lines 104 and 105. Voltage regulator also supplies oscillator 200 with 26 V DC power via line 106. The details of voltage regulator 100 are discussed below with reference to FIG. 5.” Col. 11:64 – Col. 12:5; see also Col. 12:50 – Col. 13:31.

UU. New Claim 84

For ease of analysis, new independent claim 84 is shown below with pseudo-amendments illustrating the differences between new claim 84 and claim 27 of the `183 Patent following the first reexamination proceeding.

`183 Patent Claim Language	`183 Patent Support
84. A capacitive responsive electronic switching circuit for a controlled keypad device comprising:	See Claim 27.
an oscillator providing a periodic output signal having a predefined frequency;	See Claim 27.
a microcontroller using the periodic output signal from the oscillator, the microcontroller selectively providing signal output frequencies to a closely spaced array of input touch terminals of a keypad, the input touch terminals comprising first and second input touch terminals, <u>wherein a peak voltage of the signal output frequencies is greater than a supply voltage;</u>	See Figures 4, 5, 11; and Claims 8, 12, 16, 27 and 37. The `183 Patent discloses “The touch detection circuit of the present invention features operation at frequencies at or above 50 kHz and preferably at or above 800 kHz to minimize the effects of surface contamination from materials such a [sic] skin oils and water. It also offers improvements in detection sensitivity that allow close control of the degree of proximity (ideally very close proximity) that is required for actuation and to enable employment of a multiplicity of small sized touch terminals in a physically close array such as a keyboard.” Col. 5:49-57. The `183 Patent discloses “In a first preferred

`183 Patent Claim Language	`183 Patent Support
	<p>embodiment the circuit offers enhanced detection sensitivity to allow reliable operation with small (finger size) touch pads.” Col. 6:1-3.</p> <p>The `183 Patent discloses “Although the preferred frequency is at or above 100 kHz, and more preferably at or above 800 kHz, it is conceivable that frequencies as low as 50 kHz could be used provided the frequency creates a difference in the impedance paths of adjacent pads that is sufficient enough to accurately distinguish between an intended touch and the touch of an adjacent pad. Use of frequencies as low as 50 kHz may also be possible depending upon the type of glass or covering or the thickness thereof used for the touch pad.” Col. 11:19-27.</p> <p>The `183 Patent discloses “Having provided a basis for the use of higher frequencies, the basic construction of the electronic switching circuit constructed in accordance with a first embodiment of the present invention is now described with reference to FIG. 4. The electronic switching circuit includes a voltage regulator 100 including input lines 101 and 102 for receiving a 24 V AC line voltage and a line 103 for grounding the circuit. Voltage regulator 100 converts the received AC voltage to a DC voltage and supplies a regulated 5 V DC power to an oscillator 200 via lines 104 and 105. Voltage regulator also supplies oscillator 200 with 26 V DC power via line 106. The details of voltage regulator 100 are discussed below with reference to FIG. 5.</p> <p>Upon being powered by voltage regulator 100, oscillator 200 generates a square wave with a frequency of 50 kHz, and preferably greater than 800 kHz, and having an amplitude of 26 V peak. The square wave generated by oscillator 200 is supplied via line 201 to a floating common generator 300, a touch pad shield plate 460, a touch circuit 400, and a microcontroller 500. Oscillator 200 is described below with reference</p>

`183 Patent Claim Language	`183 Patent Support
	<p>to FIG. 6.</p> <p>Floating common generator 300 receives the 26 V peak square wave from oscillator 200 and outputs a regulated floating common that is 5 volts below the square wave output from oscillator 200 and has the same phase and frequency as the received square wave. This floating common output is supplied to touch circuit 400 and microcontroller 500 via line 301 such that the output square wave from oscillator 200 and floating common output from floating common generator 300 provide power to touch circuit 400 and microcontroller 500. Details of floating common generator 300 are discussed below with reference to FIG. 7.</p> <p>Touch circuit 400 senses capacitance from a touch pad 450 via line 451 and outputs a signal to microcontroller 500 via line 401 upon detecting a capacitance to ground at touch pad 450 that exceeds a threshold value. The details of touch circuit 400 are described below with reference to FIG. 8.</p> <p>Upon receiving an indication from touch circuit 400 that a sufficient capacitance to ground (typically at least 20 pF) is present at touch pad 450, microcontroller 500 outputs a signal to a load-controlling microcontroller 600 via line 501, which is preferably a two way optical coupling bus.” Col. 11:60 – 12:33.</p> <p>The `183 Patent discloses “A preferred circuit for implementing a voltage regulator 100 is shown in FIG. 5. Voltage regulator 100 preferably includes an AC/DC convertor 110 for generating 29 V to 36 V unregulated DC on line 119. This unregulated DC power is supplied to a 5 V DC regulator 120 and to a 26 V DC regulator 130. AC/DC convertor 110 includes diodes 112, 114, 116, and 118, which rectify the supplied 24 V AC power provided on power lines 101 and 102.” Col. 12:50-57; see also Col. 12:57 – Col. 13:31.</p> <p>The `183 Patent discloses “As will be apparent</p>

`183 Patent Claim Language	`183 Patent Support
	<p>to those skilled in the art, the values of the resistors and capacitors utilized in oscillator 200 may be varied from those disclosed above to provide for different oscillator output frequencies.” Col. 14:22-25.</p> <p>The `183 Patent discloses “The oscillator circuitry shown in FIG. 6 is very stable over the temperature range of -40° C. to 105° C. The output of the touch switch circuitry drops at a rate of approximately 40 mV/°C. when temperature falls below 0° C. If application requires operation at low temperatures (-40° C.), the following three methods may be used to increase the output of the switch: increase the oscillator’s regulated supply voltage, increase the resistance of resistor 416, and use a higher gain transistor 410. All of these methods would increase sensitivity at high temperatures.” Col. 16:33-41.</p> <p>The `183 Patent discloses “A multiple touch pad circuit constructed in accordance with the second embodiment is shown in FIG. 11. In the second embodiment of FIG. 11, components similar to those in the first embodiment in FIG. 4 are designated with the same references numerals and will not be discussed in detail. The multiple touch pad circuit is a variation of the first embodiment in that it includes an array of touch circuits designated as 900₁ through 900_{nm}, which, as shown, include both the touch circuit 400 shown in FIGS. 4 and 8 and the input touch terminal pad 451 (FIG. 4). Microcontroller 500 selects each row of the touch circuits 900₁ to 900_{nm} by providing the signal from oscillator 200 to selected rows of touch circuits. In this manner, microcontroller 500 can sequentially activate the touch circuit rows and associate the received inputs from the columns of the array with the activated touch circuit(s). To keep the path length 451 between the touch pad 450 and the base to the detection transistor 410 to a minimum, the detection</p>

`183 Patent Claim Language	`183 Patent Support
	circuits 900 are physically located directly beneath the touch pads. To simplify assembly, a flexible circuit board such as vended by Sheldahl, Inc. or Circuit Etching Technics, Inc. can be used for this purpose. Ideally, the printed circuit will be fixed directly against the surface (typically glass) bearing the conductive touch pads to eliminate air gaps and the need for conductive foam pads and spring contacts which were used to fill air gaps.” Col. 18:34-59.
the first and second input touch terminals defining areas for an operator to provide an input by proximity and touch; and	See Claim 27.
a detector circuit coupled to said oscillator for receiving said periodic output signal from said oscillator, and coupled to said first and second touch terminals, said detector circuit being responsive to signals from said oscillator via said microcontroller and a presence of an operator's body capacitance to ground coupled to said first and second touch terminals when proximal or touched by the operator to provide a control output signal for actuation of the controlled keypad device, said detector circuit being configured to generate said control output signal when the operator is proximal or touches said second touch terminal after the operator is proximal or touches said first touch terminal.	See Claim 27.

VV. New Claim 85

`183 Patent Claim Language	`183 Patent Support
85. The capacitive responsive electronic switching circuit as defined in claim 84, wherein the signal output frequencies have a same Hertz value.	See Figure 11. The `183 Patent discloses “The touch detection circuit of the present invention features operation at frequencies at or above 50 kHz and preferably at or above 800 kHz to minimize the effects of surface contamination from materials such a

`183 Patent Claim Language	`183 Patent Support
	<p>[sic] skin oils and water. Col. 5:49-53.</p> <p>The `183 Patent discloses “Conversely, at 100 kHz, the glass impedance drops to approximately 1 MΩ resulting in the impedance of the path to ground for pad 59 being twice that of the touched pad 57. For cases where background noise and temperature drifts are comparatively small, a 100 kHz oscillator frequency would allow a sufficiently low detection threshold to be set to differentiate between the signal changes induced at both pads by a human touch opposite a single pad. At 800 kHz, the impedance of the glass drops to 200 kΩ or lower giving a ratio of a greater than 5 to 1 impedance difference between the paths to ground of the touched pad 57 and adjacent pads 59. In fact, the impedance ratio may exceed 10 to 1, as illustrated in the calculation below. This allows the detection threshold for the touched pad to be set well below that of an adjacent pad resulting in a much lower incidence of inadvertent actuation of adjacent touch pads to that of the touched pad. Ideally, the frequency of operation would be kept at the 800 kHz of the preferred embodiment or even higher. However, as noted earlier, higher frequency operation forces the use of more expensive components and designs. For applications where thermal drift and electronic noise levels are low, operation at or near 100 kHz may be possible. However, at 10 kHz and below, the impedance of the glass becomes much greater than that of likely water bridges between pads resulting in adjacent pads being effected as much by a touch as the touched pad itself. Although the preferred frequency is at or above 100 kHz, and more preferably at or above 800 kHz, it is conceivable that frequencies as low as 50 kHz could be used provided the frequency creates a difference in the impedance paths of adjacent pads that is sufficient enough to accurately distinguish between an intended touch and the touch of an adjacent pad. Use of frequencies as low as 50 kHz may also be</p>

`183 Patent Claim Language	`183 Patent Support
	<p>possible depending upon the type of glass or covering or the thickness thereof used for the touch pad. Col. 10:60 – Col. 11:27.</p> <p>The `183 Patent discloses “As will be apparent to those skilled in the art, the values of the resistors and capacitors utilized in oscillator 200 may be varied from those disclosed above to provide for different oscillator output frequencies. As discussed above, however, oscillator 200 is preferably constructed so as to output a square wave having a frequency of 50 kHz or greater, and more preferably, of 800 kHz or greater. Col. 14:22-28.</p> <p>The `183 Patent disclosed “The combination of oscillator voltage, frequency and transistor gain bandwidth product that is used will necessarily vary with the cost, safety and reliability requirements of a given application.” Col. 14:65 – Col. 15:1.</p>

WW. New Claim 86

`183 Patent Claim Language	`183 Patent Support
<p>86. The capacitive responsive electronic switching circuit as defined in claim 84, wherein each signal output frequency is selected from a plurality of Hertz values.</p>	<p>See Figure 11.</p> <p>The `183 Patent discloses “The touch detection circuit of the present invention features operation at frequencies at or above 50 kHz and preferably at or above 800 kHz to minimize the effects of surface contamination from materials such a [sic] skin oils and water. Col. 5:49-53.</p> <p>The `183 Patent discloses “Conversely, at 100 kHz, the glass impedance drops to approximately 1 MΩ resulting in the impedance of the path to ground for pad 59 being twice that of the touched pad 57. For cases where background noise and temperature drifts are comparatively small, a 100 kHz oscillator frequency would allow a sufficiently low detection threshold to be set to differentiate between the signal changes induced at both pads</p>

`183 Patent Claim Language	`183 Patent Support
	<p>by a human touch opposite a single pad. At 800 kHz, the impedance of the glass drops to 200 kΩ or lower giving a ratio of a greater than 5 to 1 impedance difference between the paths to ground of the touched pad 57 and adjacent pads 59. In fact, the impedance ratio may exceed 10 to 1, as illustrated in the calculation below. This allows the detection threshold for the touched pad to be set well below that of an adjacent pad resulting in a much lower incidence of inadvertent actuation of adjacent touch pads to that of the touched pad. Ideally, the frequency of operation would be kept at the 800 kHz of the preferred embodiment or even higher. However, as noted earlier, higher frequency operation forces the use of more expensive components and designs. For applications where thermal drift and electronic noise levels are low, operation at or near 100 kHz may be possible. However, at 10 kHz and below, the impedance of the glass becomes much greater than that of likely water bridges between pads resulting in adjacent pads being effected as much by a touch as the touched pad itself. Although the preferred frequency is at or above 100 kHz, and more preferably at or above 800 kHz, it is conceivable that frequencies as low as 50 kHz could be used provided the frequency creates a difference in the impedance paths of adjacent pads that is sufficient enough to accurately distinguish between an intended touch and the touch of an adjacent pad. Use of frequencies as low as 50 kHz may also be possible depending upon the type of glass or covering or the thickness thereof used for the touch pad. Col. 10:60 – Col. 11:27.</p> <p>The `183 Patent discloses “As will be apparent to those skilled in the art, the values of the resistors and capacitors utilized in oscillator 200 may be varied from those disclosed above to provide for different oscillator output frequencies. As discussed above, however, oscillator 200 is preferably constructed so as to output a square wave having a frequency of 50</p>

`183 Patent Claim Language	`183 Patent Support
	<p>kHz or greater, and more preferably, of 800 kHz or greater. Col. 14:22-28.</p> <p>The `183 Patent disclosed “The combination of oscillator voltage, frequency and transistor gain bandwidth product that is used will necessarily vary with the cost, safety and reliability requirements of a given application.” Col. 14:65 – Col. 15:1.</p>

XX. New Claim 87

`183 Patent Claim Language	`183 Patent Support
<p>87. The capacitive responsive electronic switching circuit as defined in claim 86, wherein the plurality of Hertz values comprises Hertz values greater than 50 kHz.</p>	<p>See Figure 11.</p> <p>The `183 Patent discloses “The touch detection circuit of the present invention features operation at frequencies at or above 50 kHz and preferably at or above 800 kHz to minimize the effects of surface contamination from materials such a [sic] skin oils and water. Col. 5:49-53.</p> <p>The `183 Patent discloses “Conversely, at 100 kHz, the glass impedance drops to approximately 1 MΩ resulting in the impedance of the path to ground for pad 59 being twice that of the touched pad 57. For cases where background noise and temperature drifts are comparatively small, a 100 kHz oscillator frequency would allow a sufficiently low detection threshold to be set to differentiate between the signal changes induced at both pads by a human touch opposite a single pad. At 800 kHz, the impedance of the glass drops to 200 kΩ or lower giving a ratio of a greater than 5 to 1 impedance difference between the paths to ground of the touched pad 57 and adjacent pads 59. In fact, the impedance ratio may exceed 10 to 1, as illustrated in the calculation below. This allows the detection threshold for the touched pad to be set well below that of an adjacent pad resulting in a much lower incidence of inadvertent actuation of adjacent touch pads to that of the touched pad. Ideally, the frequency of</p>

`183 Patent Claim Language	`183 Patent Support
	<p>operation would be kept at the 800 kHz of the preferred embodiment or even higher. However, as noted earlier, higher frequency operation forces the use of more expensive components and designs. For applications where thermal drift and electronic noise levels are low, operation at or near 100 kHz may be possible. However, at 10 kHz and below, the impedance of the glass becomes much greater than that of likely water bridges between pads resulting in adjacent pads being effected as much by a touch as the touched pad itself. Although the preferred frequency is at or above 100 kHz, and more preferably at or above 800 kHz, it is conceivable that frequencies as low as 50 kHz could be used provided the frequency creates a difference in the impedance paths of adjacent pads that is sufficient enough to accurately distinguish between an intended touch and the touch of an adjacent pad. Use of frequencies as low as 50 kHz may also be possible depending upon the type of glass or covering or the thickness thereof used for the touch pad. Col. 10:60 – Col. 11:27.</p> <p>The `183 Patent discloses “As will be apparent to those skilled in the art, the values of the resistors and capacitors utilized in oscillator 200 may be varied from those disclosed above to provide for different oscillator output frequencies. As discussed above, however, oscillator 200 is preferably constructed so as to output a square wave having a frequency of 50 kHz or greater, and more preferably, of 800 kHz or greater. Col. 14:22-28.</p> <p>The `183 Patent disclosed “The combination of oscillator voltage, frequency and transistor gain bandwidth product that is used will necessarily vary with the cost, safety and reliability requirements of a given application.” Col. 14:65 – Col. 15:1.</p>

YY. New Claim 88

`183 Patent Claim Language	`183 Patent Support
<p>88. The capacitive responsive electronic switching circuit as defined in claim 86, wherein the plurality of Hertz values comprises Hertz values greater than 100 kHz.</p>	<p>See Figure 11.</p> <p>The `183 Patent discloses “The touch detection circuit of the present invention features operation at frequencies at or above 50 kHz and preferably at or above 800 kHz to minimize the effects of surface contamination from materials such a [sic] skin oils and water. Col. 5:49-53.</p> <p>The `183 Patent discloses “Conversely, at 100 kHz, the glass impedance drops to approximately 1 MΩ resulting in the impedance of the path to ground for pad 59 being twice that of the touched pad 57. For cases where background noise and temperature drifts are comparatively small, a 100 kHz oscillator frequency would allow a sufficiently low detection threshold to be set to differentiate between the signal changes induced at both pads by a human touch opposite a single pad. At 800 kHz, the impedance of the glass drops to 200 kΩ or lower giving a ratio of a greater than 5 to 1 impedance difference between the paths to ground of the touched pad 57 and adjacent pads 59. In fact, the impedance ratio may exceed 10 to 1, as illustrated in the calculation below. This allows the detection threshold for the touched pad to be set well below that of an adjacent pad resulting in a much lower incidence of inadvertent actuation of adjacent touch pads to that of the touched pad. Ideally, the frequency of operation would be kept at the 800 kHz of the preferred embodiment or even higher. However, as noted earlier, higher frequency operation forces the use of more expensive components and designs. For applications where thermal drift and electronic noise levels are low, operation at or near 100 kHz may be possible. However, at 10 kHz and below, the impedance of the glass becomes much greater than that of likely water bridges between pads resulting in adjacent pads being effected as much by a touch as the touched pad itself. Although the preferred frequency is at</p>

`183 Patent Claim Language	`183 Patent Support
	<p>or above 100 kHz, and more preferably at or above 800 kHz, it is conceivable that frequencies as low as 50 kHz could be used provided the frequency creates a difference in the impedance paths of adjacent pads that is sufficient enough to accurately distinguish between an intended touch and the touch of an adjacent pad. Use of frequencies as low as 50 kHz may also be possible depending upon the type of glass or covering or the thickness thereof used for the touch pad. Col. 10:60 – Col. 11:27.</p> <p>The `183 Patent discloses “As will be apparent to those skilled in the art, the values of the resistors and capacitors utilized in oscillator 200 may be varied from those disclosed above to provide for different oscillator output frequencies. As discussed above, however, oscillator 200 is preferably constructed so as to output a square wave having a frequency of 50 kHz or greater, and more preferably, of 800 kHz or greater. Col. 14:22-28.</p> <p>The `183 Patent disclosed “The combination of oscillator voltage, frequency and transistor gain bandwidth product that is used will necessarily vary with the cost, safety and reliability requirements of a given application.” Col. 14:65 – Col. 15:1.</p>

ZZ. New Claim 89

`183 Patent Claim Language	`183 Patent Support
<p>89. The capacitive responsive electronic switching circuit as defined in claim 86, wherein the plurality of Hertz values comprises Hertz values greater than 800 kHz.</p>	<p>See Fig. 11.</p> <p>The `183 Patent discloses “The touch detection circuit of the present invention features operation at frequencies at or above 50 kHz and preferably at or above 800 kHz to minimize the effects of surface contamination from materials such a [sic] skin oils and water. Col. 5:49-53.</p> <p>The `183 Patent discloses “At 800 kHz, the impedance of the glass drops to 200 kΩ or lower</p>

`183 Patent Claim Language	`183 Patent Support
	<p>giving a ratio of a greater than 5 to 1 impedance difference between the paths to ground of the touched pad 57 and adjacent pads 59. In fact, the impedance ratio may exceed 10 to 1, as illustrated in the calculation below. This allows the detection threshold for the touched pad to be set well below that of an adjacent pad resulting in a much lower incidence of inadvertent actuation of adjacent touch pads to that of the touched pad. Ideally, the frequency of operation would be kept at the 800 kHz of the preferred embodiment or even higher. However, as noted earlier, higher frequency operation forces the use of more expensive components and designs. For applications where thermal drift and electronic noise levels are low, operation at or near 100 kHz may be possible. However, at 10 kHz and below, the impedance of the glass becomes much greater than that of likely water bridges between pads resulting in adjacent pads being effected as much by a touch as the touched pad itself. Although the preferred frequency is at or above 100 kHz, and more preferably at or above 800 kHz, it is conceivable that frequencies as low as 50 kHz could be used provided the frequency creates a difference in the impedance paths of adjacent pads that is sufficient enough to accurately distinguish between an intended touch and the touch of an adjacent pad. Use of frequencies as low as 50 kHz may also be possible depending upon the type of glass or covering or the thickness thereof used for the touch pad. Col. 11:1-27.</p> <p>The `183 Patent discloses “As will be apparent to those skilled in the art, the values of the resistors and capacitors utilized in oscillator 200 may be varied from those disclosed above to provide for different oscillator output frequencies. As discussed above, however, oscillator 200 is preferably constructed so as to output a square wave having a frequency of 50 kHz or greater, and more preferably, of 800 kHz or greater. Col. 14:22-28.</p>

`183 Patent Claim Language	`183 Patent Support
	<p>The `183 Patent disclosed “The combination of oscillator voltage, frequency and transistor gain bandwidth product that is used will necessarily vary with the cost, safety and reliability requirements of a given application.” Col. 14:65 – Col. 15:1.</p>

AAA. New Claim 90

`183 Patent Claim Language	`183 Patent Support
<p>90. The capacitive responsive electronic switching circuit as defined in claim 84, wherein the supply voltage is a battery supply voltage.</p>	<p>The `183 Patent discloses “It will be apparent to those skilled in the art, that various components of voltage regulator 100 may be added or excluded depending upon the source of power available to power the oscillator 200. For example, if the available power is a 110 V AC 60 Hz commercial power line, a transformer may be added to convert the 100 V AC power to 24 V AC. Alternatively, if a DC batter is used, the AC/DC convertor among other components may be eliminated.” Col 13:23-31.</p>

BBB. New Claim 91

`183 Patent Claim Language	`183 Patent Support
<p>91. The capacitive responsive electronic switching circuit as defined in claim 84, wherein the supply voltage is a voltage regulator supply voltage.</p>	<p>Figures 4, 5, 11, and 12.</p> <p>The `183 Patent discloses “The electronic switching circuit includes a voltage regulator 100 including input lines 101 and 102 for receiving a 24 V AC line voltage and a line 103 for grounding the circuit. Voltage regulator 100 converts the received AC voltage to a DC voltage and supplies a regulated 5 V DC power to an oscillator 200 via lines 104 and 105. Voltage regulator also supplies oscillator 200 with 26 V DC power via line 106. The details of voltage regulator 100 are discussed below with reference to FIG. 5.” Col. 11:64 – Col. 12:5; see also Col. 12:50 – Col. 13:31.</p>

CCC. New Claim 92

For ease of analysis, new dependent claim 92 is shown below with pseudo-amendments illustrating the differences between new claim 92 and claim 28 of the `183 Patent following the first reexamination proceeding.

`183 Patent Claim Language	`183 Patent Support
<p>92. The capacitive responsive electronic switching circuit as defined in claim 84, wherein said detector circuit <u>generates is configured to generate</u> said control <u>output</u> signal only when the operator is proximal or touches said second touch terminal within a predetermined time period after the operator is proximal or touches said first touch terminal.</p>	<p>See Claims 27 and 28.</p>

DDD. New Claim 93

For ease of analysis, new dependent claim 93 is shown below with pseudo-amendments illustrating the differences between new claim 93 and claim 36 of the `183 Patent following the first reexamination proceeding.

`183 Patent Claim Language	`183 Patent Support
<p>93. The capacitive responsive electronic switching circuit as defined in claim 84, and further including <u>comprising</u> an indicator for indicating when said the detector circuit <u>determines has determined</u> that the operator is proximal or touches said second touch terminal.</p>	<p>See Claims 32 and 36.</p> <p>The `183 Patent discloses “The microprocessor also allows the use of visual indicators such as LEDs or annunciators such as a bell or tone generator to confirm the actuation of a given touch switch or switches. This is particularly useful in cases where a sequence of actuations is required before an action occurs. The feedback to the operator provided by a visual or audio indicator activated by the microprocessor in response to intermediate touches in a required sequence can minimize time lost and/or frustration on the part of the operator due to failed actuations from partial touches or wrong actuations from touching the wrong pad in a given required sequence or combination of</p>

`183 Patent Claim Language	`183 Patent Support
	<p>touches.” Col. 6:31-42.</p> <p>The `183 Patent discloses “A further option is to provide one or more LEDs 2205 or audible annunciators for visual or audible feedback to the operator. Specifically, in FIG. 19 the LED 2205 will come on when button 2201 has been successfully activated to cue the operator that it is time to move to button 2202. Where required a second LED with a different color than the first (yellow for the first LED and red for the second) can be provided to provide visual confirmation that the second button 2202 has been activated or that the required combination of the two buttons has been activated. Two different audible tone or sound generators could also be used in lieu of the LEDs to provide feedback to the operator.” Col. 23:1-12.</p> <p>The `183 Patent discloses “A red LED 2305 on top of the device shows the completion of the two step turn-on and activation of output relay 2310.” Col. 23:28-30.</p>

EEE. New Claim 94

`183 Patent Claim Language	`183 Patent Support
<p>94. The capacitive responsive electronic switching circuit as defined in claim 84, wherein the detector circuit is configured to inhibit the control output signal unless the operator is proximal or touches said second touch terminal after the operator is proximal or touches said first touch terminal.</p>	<p>See Figures 19, 20A-C; and Claims 28 and 35.</p> <p>The `183 Patent discloses “In another embodiment a method to prevent inadvertent so actuations is to require a multi-step process. Referring to FIG. 19, a device is shown having a first palm button 2201, a second palm button 2202, and an indicator light 2205. Palm button 2201 has to be activated first and then button 2202 has to be activated within a 2 second time window before a desired actuation can occur.” Col. 22:49-55.</p> <p>The `183 Patent discloses “In a variation of the multi-step process, two touch plates within a housing (one vertical and one horizontal) are used to provide a two-step turn-on. Referring to</p>

`183 Patent Claim Language	`183 Patent Support
	<p>FIGS. 20A-C, the first step to actuate the output relay 2310, is initiated when the operator inserts his hands and touches the vertical touch sensor 2301 with the dorsal side of the hands. A yellow LED 2304 on top of the device show the successful completion of the first step. The second step is to flip the hand over and touch the horizontal touch sensor 2302 with the palmar side of the hand. A red LED 2305 on top of the device shows the completion of the two step turn-on and activation of output relay 2310. The flipping action of the hand in the second step causes the forearm muscles to flex, thereby reducing stiffness and fatigue. Also, the hands, and arms can rest on the run bar until the machine cycle is complete. The second step of the two-step turn-on must occur within some predetermined time (for example 2 seconds) after the release of vertical touch sensor or the first step must be repeated.” Col. 23:19-36.</p>

FFF. New Claim 95

For ease of analysis, new independent claim 95 is shown below with pseudo-amendments illustrating the differences between new claim 95 and claim 27 of the `183 Patent following the first reexamination proceeding.

`183 Patent Claim Language	`183 Patent Support
<p>95. A capacitive responsive electronic switching circuit for a controlled keypad device comprising:</p>	<p>See Claim 27.</p>
<p>an oscillator providing a periodic output signal having a predefined frequency;</p>	<p>See Claim 27.</p>
<p>a microcontroller using the periodic output signal from the oscillator, the microcontroller selectively providing signal output frequencies to a closely spaced array of input touch terminals of a keypad, <u>wherein the selectively providing comprises the microcontroller selectively providing a signal output frequency to</u></p>	<p>See Figures 4, 5, 11; and Claims 8, 12, 16, 27 and 37.</p> <p>The `183 Patent discloses “The touch detection circuit of the present invention features operation at frequencies at or above 50 kHz and preferably at or above 800 kHz to minimize the effects of surface contamination from materials such a</p>

`183 Patent Claim Language	`183 Patent Support
<p><u>each row of the closed spaced array of input touch terminals of the keypad, the input touch terminals comprising first and second input touch terminals, and wherein a peak voltage of the signal output frequencies is greater than a supply voltage;</u></p>	<p>[sic] skin oils and water. It also offers improvements in detection sensitivity that allow close control of the degree of proximity (ideally very close proximity) that is required for actuation and to enable employment of a multiplicity of small sized touch terminals in a physically close array such as a keyboard.” Col. 5:49-57.</p> <p>The `183 Patent discloses “In a first preferred embodiment the circuit offers enhanced detection sensitivity to allow reliable operation with small (finger size) touch pads.” Col. 6:1-3.</p> <p>The `183 Patent discloses “Although the preferred frequency is at or above 100 kHz, and more preferably at or above 800 kHz, it is conceivable that frequencies as low as 50 kHz could be used provided the frequency creates a difference in the impedance paths of adjacent pads that is sufficient enough to accurately distinguish between an intended touch and the touch of an adjacent pad. Use of frequencies as low as 50 kHz may also be possible depending upon the type of glass or covering or the thickness thereof used for the touch pad.” Col. 11:19-27.</p> <p>The `183 Patent discloses “Having provided a basis for the use of higher frequencies, the basic construction of the electronic switching circuit constructed in accordance with a first embodiment of the present invention is now described with reference to FIG. 4. The electronic switching circuit includes a voltage regulator 100 including input lines 101 and 102 for receiving a 24 V AC line voltage and a line 103 for grounding the circuit. Voltage regulator 100 converts the received AC voltage to a DC voltage and supplies a regulated 5 V DC power to an oscillator 200 via lines 104 and 105. Voltage regulator also supplies oscillator 200 with 26 V DC power via line 106. The details of voltage regulator 100 are discussed below with</p>

`183 Patent Claim Language	`183 Patent Support
	<p>reference to FIG. 5.</p> <p>Upon being powered by voltage regulator 100, oscillator 200 generates a square wave with a frequency of 50 kHz, and preferably greater than 800 kHz, and having an amplitude of 26 V peak. The square wave generated by oscillator 200 is supplied via line 201 to a floating common generator 300, a touch pad shield plate 460, a touch circuit 400, and a microcontroller 500. Oscillator 200 is described below with reference to FIG. 6.</p> <p>Floating common generator 300 receives the 26 V peak square wave from oscillator 200 and outputs a regulated floating common that is 5 volts below the square wave output from oscillator 200 and has the same phase and frequency as the received square wave. This floating common output is supplied to touch circuit 400 and microcontroller 500 via line 301 such that the output square wave from oscillator 200 and floating common output from floating common generator 300 provide power to touch circuit 400 and microcontroller 500. Details of floating common generator 300 are discussed below with reference to FIG. 7.</p> <p>Touch circuit 400 senses capacitance from a touch pad 450 via line 451 and outputs a signal to microcontroller 500 via line 401 upon detecting a capacitance to ground at touch pad 450 that exceeds a threshold value. The details of touch circuit 400 are described below with reference to FIG. 8.</p> <p>Upon receiving an indication from touch circuit 400 that a sufficient capacitance to ground (typically at least 20 pF) is present at touch pad 450, microcontroller 500 outputs a signal to a load-controlling microcontroller 600 via line 501, which is preferably a two way optical coupling bus.” Col. 11:60 – 12:33.</p> <p>The `183 Patent discloses “A preferred circuit for implementing a voltage regulator 100 is shown in FIG. 5. Voltage regulator 100 preferably includes an AC/DC convertor 110 for</p>

`183 Patent Claim Language	`183 Patent Support
	<p>generating 29 V to 36 V unregulated DC on line 119. This unregulated DC power is supplied to a 5 V DC regulator 120 and to a 26 V DC regulator 130. AC/DC convertor 110 includes diodes 112, 114, 116, and 118, which rectify the supplied 24 V AC power provided on power lines 101 and 102.” Col. 12:50-57; see also Col. 12:57 – Col. 13:31.</p> <p>The `183 Patent discloses “As will be apparent to those skilled in the art, the values of the resistors and capacitors utilized in oscillator 200 may be varied from those disclosed above to provide for different oscillator output frequencies.” Col. 14:22-25.</p> <p>The `183 Patent discloses “The oscillator circuitry shown in FIG. 6 is very stable over the temperature range of -40° C. to 105° C. The output of the touch switch circuitry drops at a rate of approximately 40 mV/°C. when temperature falls below 0° C. If application requires operation at low temperatures (-40° C.), the following three methods may be used to increase the output of the switch: increase the oscillator’s regulated supply voltage, increase the resistance of resistor 416, and use a higher gain transistor 410. All of these methods would increase sensitivity at high temperatures.” Col. 16:33-41.</p> <p>The `183 Patent discloses “A multiple touch pad circuit constructed in accordance with the second embodiment is shown in FIG. 11. In the second embodiment of FIG. 11, components similar to those in the first embodiment in FIG. 4 are designated with the same references numerals and will not be discussed in detail. The multiple touch pad circuit is a variation of the first embodiment in that it includes an array of touch circuits designated as 900₁ through 900_{nm}, which, as shown, include both the touch circuit 400 shown in FIGS. 4 and 8 and the input touch terminal pad 451 (FIG. 4).</p>

`183 Patent Claim Language	`183 Patent Support
	<p>Microcontroller 500 selects each row of the touch circuits 900₁ to 900_{nm} by providing the signal from oscillator 200 to selected rows of touch circuits. In this manner, microcontroller 500 can sequentially activate the touch circuit rows and associate the received inputs from the columns of the array with the activated touch circuit(s). To keep the path length 451 between the touch pad 450 and the base to the detection transistor 410 to a minimum, the detection circuits 900 are physically located directly beneath the touch pads. To simplify assembly, a flexible circuit board such as vended by Sheldahl, Inc. or Circuit Etching Technics, Inc. can be used for this purpose. Ideally, the printed circuit will be fixed directly against the surface (typically glass) bearing the conductive touch pads to eliminate air gaps and the need for conductive foam pads and spring contacts which were used to fill air gaps.” Col. 18:34-59.</p>
<p>the first and second input touch terminals defining areas for an operator to provide an input by proximity and touch; and</p>	<p>See Claim 27.</p>
<p>a detector circuit coupled to said oscillator for receiving said periodic output signal from said oscillator, and coupled to said first and second touch terminals, said detector circuit being responsive to signals from said oscillator via said microcontroller and a presence of an operator's body capacitance to ground coupled to said first and second touch terminals when proximal or touched by the operator to provide a control output signal for actuation of the controlled keypad device, said detector circuit being configured to generate said control output signal when the operator is proximal or touches said second touch terminal after the operator is proximal or touches said first touch terminal.</p>	<p>See Claim 27.</p>

GGG. New Claim 96

`183 Patent Claim Language	`183 Patent Support
<p>96. The capacitive responsive electronic switching circuit as defined in claim 95, wherein each signal output frequency selectively provided to each row of the closely spaced array of input touch terminals of the keypad has a same Hertz value.</p>	<p>See Figure 11.</p> <p>The `183 Patent discloses “The touch detection circuit of the present invention features operation at frequencies at or above 50 kHz and preferably at or above 800 kHz to minimize the effects of surface contamination from materials such a [sic] skin oils and water. Col. 5:49-53.</p> <p>The `183 Patent discloses “Conversely, at 100 kHz, the glass impedance drops to approximately 1 MΩ resulting in the impedance of the path to ground for pad 59 being twice that of the touched pad 57. For cases where background noise and temperature drifts are comparatively small, a 100 kHz oscillator frequency would allow a sufficiently low detection threshold to be set to differentiate between the signal changes induced at both pads by a human touch opposite a single pad. At 800 kHz, the impedance of the glass drops to 200 kΩ or lower giving a ratio of a greater than 5 to 1 impedance difference between the paths to ground of the touched pad 57 and adjacent pads 59. In fact, the impedance ratio may exceed 10 to 1, as illustrated in the calculation below. This allows the detection threshold for the touched pad to be set well below that of an adjacent pad resulting in a much lower incidence of inadvertent actuation of adjacent touch pads to that of the touched pad. Ideally, the frequency of operation would be kept at the 800 kHz of the preferred embodiment or even higher. However, as noted earlier, higher frequency operation forces the use of more expensive components and designs. For applications where thermal drift and electronic noise levels are low, operation at or near 100 kHz may be possible. However, at 10 kHz and below, the impedance of the glass becomes much greater than that of likely water bridges between pads resulting in adjacent pads being effected as much by a touch as the touched pad itself. Although the preferred frequency is at</p>

`183 Patent Claim Language	`183 Patent Support
	<p>or above 100 kHz, and more preferably at or above 800 kHz, it is conceivable that frequencies as low as 50 kHz could be used provided the frequency creates a difference in the impedance paths of adjacent pads that is sufficient enough to accurately distinguish between an intended touch and the touch of an adjacent pad. Use of frequencies as low as 50 kHz may also be possible depending upon the type of glass or covering or the thickness thereof used for the touch pad. Col. 10:60 – Col. 11:27.</p> <p>The `183 Patent discloses “As will be apparent to those skilled in the art, the values of the resistors and capacitors utilized in oscillator 200 may be varied from those disclosed above to provide for different oscillator output frequencies. As discussed above, however, oscillator 200 is preferably constructed so as to output a square wave having a frequency of 50 kHz or greater, and more preferably, of 800 kHz or greater. Col. 14:22-28.</p> <p>The `183 Patent disclosed “The combination of oscillator voltage, frequency and transistor gain bandwidth product that is used will necessarily vary with the cost, safety and reliability requirements of a given application.” Col. 14:65 – Col. 15:1.</p>

HHH. New Claim 97

`183 Patent Claim Language	`183 Patent Support
<p>97. The capacitive responsive electronic switching circuit as defined in claim 95, wherein each signal output frequency selectively provided to each row of the closely spaced array of input touch terminals of the keypad is selected from a plurality of Hertz values.</p>	<p>See Figure 11.</p> <p>The `183 Patent discloses “The touch detection circuit of the present invention features operation at frequencies at or above 50 kHz and preferably at or above 800 kHz to minimize the effects of surface contamination from materials such a [sic] skin oils and water. Col. 5:49-53.</p> <p>The `183 Patent discloses “Conversely, at 100 kHz, the glass impedance drops to</p>

`183 Patent Claim Language	`183 Patent Support
	<p>approximately 1 MΩ resulting in the impedance of the path to ground for pad 59 being twice that of the touched pad 57. For cases where background noise and temperature drifts are comparatively small, a 100 kHz oscillator frequency would allow a sufficiently low detection threshold to be set to differentiate between the signal changes induced at both pads by a human touch opposite a single pad. At 800 kHz, the impedance of the glass drops to 200 kΩ or lower giving a ratio of a greater than 5 to 1 impedance difference between the paths to ground of the touched pad 57 and adjacent pads 59. In fact, the impedance ratio may exceed 10 to 1, as illustrated in the calculation below. This allows the detection threshold for the touched pad to be set well below that of an adjacent pad resulting in a much lower incidence of inadvertent actuation of adjacent touch pads to that of the touched pad. Ideally, the frequency of operation would be kept at the 800 kHz of the preferred embodiment or even higher. However, as noted earlier, higher frequency operation forces the use of more expensive components and designs. For applications where thermal drift and electronic noise levels are low, operation at or near 100 kHz may be possible. However, at 10 kHz and below, the impedance of the glass becomes much greater than that of likely water bridges between pads resulting in adjacent pads being effected as much by a touch as the touched pad itself. Although the preferred frequency is at or above 100 kHz, and more preferably at or above 800 kHz, it is conceivable that frequencies as low as 50 kHz could be used provided the frequency creates a difference in the impedance paths of adjacent pads that is sufficient enough to accurately distinguish between an intended touch and the touch of an adjacent pad. Use of frequencies as low as 50 kHz may also be possible depending upon the type of glass or covering or the thickness thereof used for the touch pad. Col. 10:60 – Col. 11:27.</p>

`183 Patent Claim Language	`183 Patent Support
	<p>The `183 Patent discloses “As will be apparent to those skilled in the art, the values of the resistors and capacitors utilized in oscillator 200 may be varied from those disclosed above to provide for different oscillator output frequencies. As discussed above, however, oscillator 200 is preferably constructed so as to output a square wave having a frequency of 50 kHz or greater, and more preferably, of 800 kHz or greater. Col. 14:22-28.</p> <p>The `183 Patent disclosed “The combination of oscillator voltage, frequency and transistor gain bandwidth product that is used will necessarily vary with the cost, safety and reliability requirements of a given application.” Col. 14:65 – Col. 15:1.</p>

III. New Claim 98

`183 Patent Claim Language	`183 Patent Support
<p>98. The capacitive responsive electronic switching circuit as defined in claim 97, wherein the plurality of Hertz values comprises Hertz values greater than 50 kHz.</p>	<p>See Figure 11.</p> <p>The `183 Patent discloses “The touch detection circuit of the present invention features operation at frequencies at or above 50 kHz and preferably at or above 800 kHz to minimize the effects of surface contamination from materials such a [sic] skin oils and water. Col. 5:49-53.</p> <p>The `183 Patent discloses “Conversely, at 100 kHz, the glass impedance drops to approximately 1 MΩ resulting in the impedance of the path to ground for pad 59 being twice that of the touched pad 57. For cases where background noise and temperature drifts are comparatively small, a 100 kHz oscillator frequency would allow a sufficiently low detection threshold to be set to differentiate between the signal changes induced at both pads by a human touch opposite a single pad. At 800 kHz, the impedance of the glass drops to 200 kΩ or lower giving a ratio of a greater than 5 to 1 impedance difference between the paths to</p>

`183 Patent Claim Language	`183 Patent Support
	<p>ground of the touched pad 57 and adjacent pads 59. In fact, the impedance ratio may exceed 10 to 1, as illustrated in the calculation below. This allows the detection threshold for the touched pad to be set well below that of an adjacent pad resulting in a much lower incidence of inadvertent actuation of adjacent touch pads to that of the touched pad. Ideally, the frequency of operation would be kept at the 800 kHz of the preferred embodiment or even higher. However, as noted earlier, higher frequency operation forces the use of more expensive components and designs. For applications where thermal drift and electronic noise levels are low, operation at or near 100 kHz may be possible. However, at 10 kHz and below, the impedance of the glass becomes much greater than that of likely water bridges between pads resulting in adjacent pads being effected as much by a touch as the touched pad itself. Although the preferred frequency is at or above 100 kHz, and more preferably at or above 800 kHz, it is conceivable that frequencies as low as 50 kHz could be used provided the frequency creates a difference in the impedance paths of adjacent pads that is sufficient enough to accurately distinguish between an intended touch and the touch of an adjacent pad. Use of frequencies as low as 50 kHz may also be possible depending upon the type of glass or covering or the thickness thereof used for the touch pad. Col. 10:60 – Col. 11:27.</p> <p>The `183 Patent discloses “As will be apparent to those skilled in the art, the values of the resistors and capacitors utilized in oscillator 200 may be varied from those disclosed above to provide for different oscillator output frequencies. As discussed above, however, oscillator 200 is preferably constructed so as to output a square wave having a frequency of 50 kHz or greater, and more preferably, of 800 kHz or greater. Col. 14:22-28.</p> <p>The `183 Patent disclosed “The combination of</p>

`183 Patent Claim Language	`183 Patent Support
	oscillator voltage, frequency and transistor gain bandwidth product that is used will necessarily vary with the cost, safety and reliability requirements of a given application.” Col. 14:65 – Col. 15:1.

JJJ. New Claim 99

`183 Patent Claim Language	`183 Patent Support
<p>99. The capacitive responsive electronic switching circuit as defined in claim 97, wherein the plurality of Hertz values comprises Hertz values greater than 100 kHz.</p>	<p>See Figure 11.</p> <p>The `183 Patent discloses “The touch detection circuit of the present invention features operation at frequencies at or above 50 kHz and preferably at or above 800 kHz to minimize the effects of surface contamination from materials such a [sic] skin oils and water. Col. 5:49-53.</p> <p>The `183 Patent discloses “Conversely, at 100 kHz, the glass impedance drops to approximately 1 MΩ resulting in the impedance of the path to ground for pad 59 being twice that of the touched pad 57. For cases where background noise and temperature drifts are comparatively small, a 100 kHz oscillator frequency would allow a sufficiently low detection threshold to be set to differentiate between the signal changes induced at both pads by a human touch opposite a single pad. At 800 kHz, the impedance of the glass drops to 200 kΩ or lower giving a ratio of a greater than 5 to 1 impedance difference between the paths to ground of the touched pad 57 and adjacent pads 59. In fact, the impedance ratio may exceed 10 to 1, as illustrated in the calculation below. This allows the detection threshold for the touched pad to be set well below that of an adjacent pad resulting in a much lower incidence of inadvertent actuation of adjacent touch pads to that of the touched pad. Ideally, the frequency of operation would be kept at the 800 kHz of the preferred embodiment or even higher. However, as noted earlier, higher frequency operation forces the use of more expensive components</p>

`183 Patent Claim Language	`183 Patent Support
	<p>and designs. For applications where thermal drift and electronic noise levels are low, operation at or near 100 kHz may be possible. However, at 10 kHz and below, the impedance of the glass becomes much greater than that of likely water bridges between pads resulting in adjacent pads being effected as much by a touch as the touched pad itself. Although the preferred frequency is at or above 100 kHz, and more preferably at or above 800 kHz, it is conceivable that frequencies as low as 50 kHz could be used provided the frequency creates a difference in the impedance paths of adjacent pads that is sufficient enough to accurately distinguish between an intended touch and the touch of an adjacent pad. Use of frequencies as low as 50 kHz may also be possible depending upon the type of glass or covering or the thickness thereof used for the touch pad. Col. 10:60 – Col. 11:27.</p> <p>The `183 Patent discloses “As will be apparent to those skilled in the art, the values of the resistors and capacitors utilized in oscillator 200 may be varied from those disclosed above to provide for different oscillator output frequencies. As discussed above, however, oscillator 200 is preferably constructed so as to output a square wave having a frequency of 50 kHz or greater, and more preferably, of 800 kHz or greater. Col. 14:22-28.</p> <p>The `183 Patent disclosed “The combination of oscillator voltage, frequency and transistor gain bandwidth product that is used will necessarily vary with the cost, safety and reliability requirements of a given application.” Col. 14:65 – Col. 15:1.</p>

KKK. New Claim 100

`183 Patent Claim Language	`183 Patent Support
<p>100. The capacitive responsive electronic switching circuit as defined in claim 97, wherein the plurality of Hertz</p>	<p>See Fig. 11.</p> <p>The `183 Patent discloses “The touch detection</p>

`183 Patent Claim Language	`183 Patent Support
<p>values comprises Hertz values greater than 800 kHz.</p>	<p>circuit of the present invention features operation at frequencies at or above 50 kHz and preferably at or above 800 kHz to minimize the effects of surface contamination from materials such a [sic] skin oils and water. Col. 5:49-53.</p> <p>The `183 Patent discloses “At 800 kHz, the impedance of the glass drops to 200 kΩ or lower giving a ratio of a greater than 5 to 1 impedance difference between the paths to ground of the touched pad 57 and adjacent pads 59. In fact, the impedance ratio may exceed 10 to 1, as illustrated in the calculation below. This allows the detection threshold for the touched pad to be set well below that of an adjacent pad resulting in a much lower incidence of inadvertent actuation of adjacent touch pads to that of the touched pad. Ideally, the frequency of operation would be kept at the 800 kHz of the preferred embodiment or even higher. However, as noted earlier, higher frequency operation forces the use of more expensive components and designs. For applications where thermal drift and electronic noise levels are low, operation at or near 100 kHz may be possible. However, at 10 kHz and below, the impedance of the glass becomes much greater than that of likely water bridges between pads resulting in adjacent pads being effected as much by a touch as the touched pad itself. Although the preferred frequency is at or above 100 kHz, and more preferably at or above 800 kHz, it is conceivable that frequencies as low as 50 kHz could be used provided the frequency creates a difference in the impedance paths of adjacent pads that is sufficient enough to accurately distinguish between an intended touch and the touch of an adjacent pad. Use of frequencies as low as 50 kHz may also be possible depending upon the type of glass or covering or the thickness thereof used for the touch pad. Col. 11:1-27.</p> <p>The `183 Patent discloses “As will be apparent to those skilled in the art, the values of the</p>

`183 Patent Claim Language	`183 Patent Support
	<p>resistors and capacitors utilized in oscillator 200 may be varied from those disclosed above to provide for different oscillator output frequencies. As discussed above, however, oscillator 200 is preferably constructed so as to output a square wave having a frequency of 50 kHz or greater, and more preferably, of 800 kHz or greater. Col. 14:22-28.</p> <p>The `183 Patent disclosed “The combination of oscillator voltage, frequency and transistor gain bandwidth product that is used will necessarily vary with the cost, safety and reliability requirements of a given application.” Col. 14:65 – Col. 15:1.</p>

LLL. New Claim 101

`183 Patent Claim Language	`183 Patent Support
<p>101. The capacitive responsive electronic switching circuit as defined in claim 95, wherein the supply voltage is a battery supply voltage.</p>	<p>The `183 Patent discloses “It will be apparent to those skilled in the art, that various components of voltage regulator 100 may be added or excluded depending upon the source of power available to power the oscillator 200. For example, if the available power is a 110 V AC 60 Hz commercial power line, a transformer may be added to convert the 100 V AC power to 24 V AC. Alternatively, if a DC batter is used, the AC/DC convertor among other components may be eliminated.” Col 13:23-31.</p>

MMM. New Claim 102

`183 Patent Claim Language	`183 Patent Support
<p>102. The capacitive responsive electronic switching circuit as defined in claim 95, wherein the supply voltage is a voltage regulator supply voltage.</p>	<p>Figures 4, 5, 11, and 12.</p> <p>The `183 Patent discloses “The electronic switching circuit includes a voltage regulator 100 including input lines 101 and 102 for receiving a 24 V AC line voltage and a line 103 for grounding the circuit. Voltage regulator 100 converts the received AC voltage to a DC voltage and supplies a regulated 5 V DC power</p>

`183 Patent Claim Language	`183 Patent Support
	to an oscillator 200 via lines 104 and 105. Voltage regulator also supplies oscillator 200 with 26 V DC power via line 106. The details of voltage regulator 100 are discussed below with reference to FIG. 5.” Col. 11:64 – Col. 12:5; see also Col. 12:50 – Col. 13:31.

NNN. New Claim 103

For ease of analysis, new dependent claim 103 is shown below with pseudo-amendments illustrating the differences between new claim 103 and claim 28 of the `183 Patent following the first reexamination proceeding.

`183 Patent Claim Language	`183 Patent Support
103. The capacitive responsive electronic switching circuit as defined in claim 95, wherein said detector circuit <u>generates is configured to generate</u> said control <u>output</u> signal only when the operator is proximal or touches said second touch terminal within a predetermined time period after the operator is proximal or touches said first touch terminal.	See Claims 27 and 28.

OOO. New Claim 104

For ease of analysis, new dependent claim 104 is shown below with pseudo-amendments illustrating the differences between new claim 104 and claim 36 of the `183 Patent following the first reexamination proceeding.

`183 Patent Claim Language	`183 Patent Support
104. The capacitive responsive electronic switching circuit as defined in claim 95, and further including <u>comprising</u> an indicator for indicating when said the detector circuit determines <u>has determined</u> that the operator is proximal or touches said second touch terminal.	See Claims 32 and 36. The `183 Patent discloses “The microprocessor also allows the use of visual indicators such as LEDs or annunciators such as a bell or tone generator to confirm the actuation of a given touch switch or switches. This is particularly useful in cases where a sequence of actuations is required before an action occurs. The feedback to the operator provided by a visual or audio

`183 Patent Claim Language	`183 Patent Support
	<p>indicator activated by the microprocessor in response to intermediate touches in a required sequence can minimize time lost and/or frustration on the part of the operator due to failed actuations from partial touches or wrong actuations from touching the wrong pad in a given required sequence or combination of touches.” Col. 6:31-42.</p> <p>The `183 Patent discloses “A further option is to provide one or more LEDs 2205 or audible annunciators for visual or audible feedback to the operator. Specifically, in FIG. 19 the LED 2205 will come on when button 2201 has been successfully activated to cue the operator that it is time to move to button 2202. Where required a second LED with a different color than the first (yellow for the first LED and red for the second) can be provided to provide visual confirmation that the second button 2202 has been activated or that the required combination of the two buttons has been activated. Two different audible tone or sound generators could also be used in lieu of the LEDs to provide feedback to the operator.” Col. 23:1-12.</p> <p>The `183 Patent discloses “A red LED 2305 on top of the device shows the completion of the two step turn-on and activation of output relay 2310.” Col. 23:28-30.</p>

PPP. New Claim 105

`183 Patent Claim Language	`183 Patent Support
<p>105. The capacitive responsive electronic switching circuit as defined in claim 95, wherein the detector circuit is configured to inhibit the control output signal unless the operator is proximal or touches said second touch terminal after the operator is proximal or touches said first touch terminal.</p>	<p>See Figures 19, 20A-C; and Claims 28 and 35.</p> <p>The `183 Patent discloses “In another embodiment a method to prevent inadvertent so actuations is to require a multi-step process. Referring to FIG. 19, a device is shown having a first palm button 2201, a second palm button 2202, and an indicator light 2205. Palm button 2201 has to be activated first and then button 2202 has to be activated within a 2 second time</p>

`183 Patent Claim Language	`183 Patent Support
	<p>window before a desired actuation can occur.” Col. 22:49-55.</p> <p>The `183 Patent discloses “In a variation of the multi-step process, two touch plates within a housing (one vertical and one horizontal) are used to provide a two-step turn-on. Referring to FIGS. 20A-C, the first step to actuate the output relay 2310, is initiated when the operator inserts his hands and touches the vertical touch sensor 2301 with the dorsal side of the hands. A yellow LED 2304 on top of the device show the successful completion of the first step. The second step is to flip the hand over and touch the horizontal touch sensor 2302 with the palmar side of the hand. A red LED 2305 on top of the device shows the completion of the two step turn-on and activation of output relay 2310. The flipping action of the hand in the second step causes the forearm muscles to flex, thereby reducing stiffness and fatigue. Also, the hands, and arms can rest on the run bar until the machine cycle is complete. The second step of the two-step turn-on must occur within some predetermined time (for example 2 seconds) after the release of vertical touch sensor or the first step must be repeated.” Col. 23:19-36.</p>

QQQ. Claim 106

For ease of analysis, new independent claim 106 is shown below with pseudo-amendments illustrating the differences between new claim 106 and claim 18 of the `183 Patent following the first reexamination proceeding.

`183 Patent Claim Language	`183 Patent Support
106. A capacitive responsive electronic switching circuit comprising:	See Claim 18.
an oscillator providing a periodic output signal having a predefined frequency;	See Claim 18.
a microcontroller using the	See Figures 4, 11; and Claims 8, 12, 16, 18.

`183 Patent Claim Language	`183 Patent Support
<p>periodic output signal from the oscillator, the microcontroller selectively providing signal output frequencies to a plurality of small sized input touch terminals of a keypad, <u>wherein the selectively providing comprises the microcontroller selectively providing a signal output frequency to each row of the plurality of small sized input touch terminals of the keypad;</u></p>	<p>The `183 Patent discloses “The touch detection circuit of the present invention features operation at frequencies at or above 50kHz and preferably at or above 800 kHz to minimize the effects of surface contamination from materials such a [sic] skin oils and water. It also offers improvements in detection sensitivity that allow close control of the degree of proximity (ideally very close proximity) that is required for actuation and to enable employment of a multiplicity of small sized touch terminals in a physically close array such as a keyboard.” Col. 5:49-57.</p> <p>The `183 Patent discloses “In a first preferred embodiment the circuit offers enhanced detection sensitivity to allow reliable operation with small (finger size) touch pads.” Col. 6:1-3.</p> <p>The `183 Patent discloses “Although the preferred frequency is at or above 100 kHz, and more preferably at or above 800 kHz, it is conceivable that frequencies as low as 50 kHz could be used provided the frequency creates a difference in the impedance paths of adjacent pads that is sufficient enough to accurately distinguish between an intended touch and the touch of an adjacent pad. Use of frequencies as low as 50 kHz may also be possible depending upon the type of glass or covering or the thickness thereof used for the touch pad.” Col. 11:19-27.</p> <p>The `183 Patent discloses “Upon being powered by voltage regulator 100, oscillator 200 generates a square wave with a frequency of 50 kHz, and preferably greater than 800 kHz, and having an amplitude of 26 V peak. The square wave generated by oscillator 200 is supplied via line 201 to a floating common generator 300, a touch pad shield plate 460, a touch circuit 400, and a microcontroller 500. Oscillator 200 is described below with reference to FIG. 6.</p>

`183 Patent Claim Language	`183 Patent Support
	<p>Floating common generator 300 receives the 26 V peak square wave from oscillator 200 and outputs a regulated floating common that is 5 volts below the square wave output from oscillator 200 and has the same phase and frequency as the received square wave. This floating common output is supplied to touch circuit 400 and microcontroller 500 via line 301 such that the output square wave from oscillator 200 and floating common output from floating common generator 300 provide power to touch circuit 400 and microcontroller 500. Details of floating common generator 300 are discussed below with reference to FIG. 7.</p> <p>Touch circuit 400 senses capacitance from a touch pad 450 via line 451 and outputs a signal to microcontroller 500 via line 401 upon detecting a capacitance to ground at touch pad 450 that exceeds a threshold value. The details of touch circuit 400 are described below with reference to FIG. 8.</p> <p>Upon receiving an indication from touch circuit 400 that a sufficient capacitance to ground (typically at least 20 pF) is present at touch pad 450, microcontroller 500 outputs a signal to a load-controlling microcontroller 600 via line 501, which is preferably a two way optical coupling bus.” Col. 12:6-33.</p> <p>The `183 Patent discloses “As will be apparent to those skilled in the art, the values of the resistors and capacitors utilized in oscillator 200 may be varied from those disclosed above to provide for different oscillator output frequencies.” Col. 14:22-25.</p> <p>The `183 Patent discloses “A multiple touch pad circuit constructed in accordance with the second embodiment is shown in FIG. 11. In the second embodiment of FIG. 11, components similar to those in the first embodiment in FIG. 4 are designated with the same references numerals and will not be discussed in detail. The multiple touch pad circuit is a variation of</p>

`183 Patent Claim Language	`183 Patent Support
	<p>the first embodiment in that it includes an array of touch circuits designated as 900₁ through 900_{nm}, which, as shown, include both the touch circuit 400 shown in FIGS. 4 and 8 and the input touch terminal pad 451 (FIG. 4). Microcontroller 500 selects each row of the touch circuits 900₁ to 900_{nm} by providing the signal from oscillator 200 to selected rows of touch circuits. In this manner, microcontroller 500 can sequentially activate the touch circuit rows and associate the received inputs from the columns of the array with the activated touch circuit(s). To keep the path length 451 between the touch pad 450 and the base to the detection transistor 410 to a minimum, the detection circuits 900 are physically located directly beneath the touch pads. To simplify assembly, a flexible circuit board such as vended by Sheldahl, Inc. or Circuit Etching Technics, Inc. can be used for this purpose. Ideally, the printed circuit will be fixed directly against the surface (typically glass) bearing the conductive touch pads to eliminate air gaps and the need for conductive foam pads and spring contacts which were used to fill air gaps.” Col. 18:34-59.</p>
<p>the plurality of small sized input touch terminals defining adjacent areas on a dielectric substrate for an operator to provide inputs by proximity and touch; and</p>	<p>See Claim 18.</p>
<p>a detector circuit coupled to said oscillator for receiving said periodic output signal from said oscillator, and coupled to said input touch terminals, said detector circuit being responsive to signals from said oscillator via said microcontroller and a presence of an operator's body capacitance to ground coupled to said touch terminals when proximal or touched by the operator to provide a control output signal,</p>	<p>See Claim 18.</p>
<p>wherein said predefined frequency of said oscillator and said signal output</p>	<p>See Claim 18.</p>

`183 Patent Claim Language	`183 Patent Support
frequencies are selected to decrease a first impedance of said dielectric substrate relative to a second impedance of any contaminate that may create an electrical path on said dielectric substrate between said adjacent areas defined by the plurality of small sized input touch terminals, and wherein said detector circuit compares a sensed body capacitance change to ground proximate an input touch terminal to a threshold level to prevent inadvertent generation of the control output signal.	

RRR. New Claim 107

`183 Patent Claim Language	`183 Patent Support
107. The capacitive responsive switching circuit as defined in claim 106, wherein said oscillator provides a periodic output signal having a frequency of 800 kHz or greater.	See Claim 19.

SSS. New Claim 108

For ease of analysis, new dependent claim 108 is shown below with pseudo-amendments illustrating the differences between new claim 108 and claim 33 of the `183 Patent following the first reexamination proceeding.

`183 Patent Claim Language	`183 Patent Support
108. The capacitive responsive electronic switching circuit as defined in claim 106, further comprising wherein said detector circuit compares the sensed body capacitance change <u>to ground proximate the input touch terminal</u> is caused by the <u>operator's</u> body capacitance decreasing an input touch terminal signal on the detector circuit, and wherein the sensed body	See Claims 1, 18, 28, and 33. The `183 Patent discloses “The touch detection circuit of the present invention features operation at frequencies at or above 50 kHz and preferably at or above 800 kHz to minimize the effects of surface contamination from materials such a [sic] skin oils and water. It also offers improvements in detection sensitivity that allow

`183 Patent Claim Language	`183 Patent Support
<p>capacitance change to ground when proximate to the input touch terminal is compared to a second threshold level to generate the control output signal.</p>	<p>close control of the degree of proximity (ideally very close proximity) that is required for actuation and to enable employment of a multiplicity of small sized touch terminals in a physically close array such as a keyboard.” Col. 5:49-57.</p> <p>The `183 Patent discloses “Touch circuit 400 senses capacitance from a touch pad 450 via line 451 and outputs a signal to microcontroller 500 via line 401 upon detecting a capacitance to ground at touch pad 450 that exceeds a threshold value. The details of touch circuit 400 are described below with reference to FIG. 8.” Col. 12:24-28.</p> <p>The `183 Patent discloses “As can be seen, at 1 kHz, the capacitive impedance of the glass is much greater than the nominal 1 MΩ of the water bridge across the pads. As a result, at 1 kHz, there would be little difference in the impedance paths to ground of the two adjacent pads when either is touched. This would result in the voltage on both pads being pulled towards ground by comparable amounts. Conversely, at 100 kHz, the glass impedance drops to approximately 1 MΩ resulting in the impedance of the path to ground for pad 59 being twice that of the touched pad 57. For cases where background noise and temperature drifts are comparatively small, a 100 kHz oscillator frequency would allow a sufficiently low detection threshold to be set to differentiate between the signal changes induced at both pads by a human touch opposite a single pad. At 800 kHz, the impedance of the glass drops to 200 kΩ or lower giving a ratio of a greater than 5 to 1 impedance difference between the paths to ground of the touched pad 57 and adjacent pads 59. In fact, the impedance ratio may exceed 10 to 1, as illustrated in the calculation below. This allows the detection threshold for the touched pad to be set well below that of an adjacent pad resulting in a much lower incidence of</p>

`183 Patent Claim Language	`183 Patent Support
	<p>inadvertent actuation of adjacent touch pads to that of the touched pad. Col. 10:54 – Col. 11:9.</p> <p>The `183 Patent discloses “As stated above, the operator’s body includes a capacitance to ground, which may range in a typical person from between 20 to 300 pF. The base terminal of transistor 410 is coupled to it’s [sic] emitter by resistor 412 such that unless capacitance is present by the user touching the touch pad 450, transistor 410 will not be forward biased and will not conduct. Thus, when touch pad 450 is not touched, the output signal at the collector terminal of transistor 410 and across pulse stretcher circuit 417 will be zero volts. When, however, a person touches the touch pad 450, that person’s body capacitance to ground couples the base of transistor 410 to ground 103 through resistor 413, thereby forward biasing transistor 410 into conduction. This charges capacitor 418 providing a positive DC voltage with respect to the line 301 and causes the output of the Schmitt trigger 420 to go low. Diode 414 is coupled across the base to emitter junction of transistor 410 to clamp the base emitter reverse bias voltage to –0.7V and also reduce the forward recovery and turn-on time. Col. 15:29-47.</p>

TTT. New Claim 109

For ease of analysis, new dependent claim 109 is shown below with pseudo-amendments illustrating the differences between new claim 109 and claim 34 of the `183 Patent following the first reexamination proceeding.

`183 Patent Claim Language	`183 Patent Support
<p>109. The capacitive responsive electronic switching circuit as defined in claim 106, further comprising wherein said detector circuit compares the sensed body capacitance change <u>to ground proximate the input touch terminal</u> is caused by the <u>operator’s</u> body capacitance decreasing an input touch terminal signal amplitude on</p>	<p>See Claims 1, 18, 28, and 34.</p> <p>The `183 Patent discloses “Another method for implementing capacitive touch switches relies on the change in capacitive coupling between a touch terminal and ground. Systems utilizing such a method are described in U.S. Pat. No. 4,758,735 and U.S. Pat. No. 5,087,825. With</p>

`183 Patent Claim Language	`183 Patent Support
<p>the detector <u>circuit, and wherein the sensed body capacitance change to ground when proximate to the input touch terminal is compared</u> to a second threshold level to generate the control output signal.</p>	<p>this methodology the detection circuit consists of an oscillator (or AC line voltage derivative) providing a signal to a touch terminal whose voltage is then monitored by a detector. The touch terminal is driven in electrical series with other components that function in part as a charge pump. The touch of an operator then provides a capacitive short to ground via the operator's own body capacitance that lowers the amplitude of oscillator voltage seen at the touch terminal.” Col. 3:44-56.</p> <p>The `183 Patent discloses “The touch detection circuit of the present invention features operation at frequencies at or above 50 kHz and preferably at or above 800 kHz to minimize the effects of surface contamination from materials such a [sic] skin oils and water. It also offers improvements in detection sensitivity that allow close control of the degree of proximity (ideally very close proximity) that is required for actuation and to enable employment of a multiplicity of small sized touch terminals in a physically close array such as a keyboard.” Col. 5:49-57.</p> <p>The `183 Patent discloses “Touch circuit 400 senses capacitance from a touch pad 450 via line 451 and outputs a signal to microcontroller 500 via line 401 upon detecting a capacitance to ground at touch pad 450 that exceeds a threshold value. The details of touch circuit 400 are described below with reference to FIG. 8.” Col. 12:24-28.</p> <p>The `183 Patent discloses “As can be seen, at 1 kHz, the capacitive impedance of the glass is much greater than the nominal 1 MΩ of the water bridge across the pads. As a result, at 1 kHz, there would be little difference in the impedance paths to ground of the two adjacent pads when either is touched. This would result in the voltage on both pads being pulled towards ground by comparable amounts. Conversely, at</p>

`183 Patent Claim Language	`183 Patent Support
	<p>100 kHz, the glass impedance drops to approximately 1 MΩ resulting in the impedance of the path to ground for pad 59 being twice that of the touched pad 57. For cases where background noise and temperature drifts are comparatively small, a 100 kHz oscillator frequency would allow a sufficiently low detection threshold to be set to differentiate between the signal changes induced at both pads by a human touch opposite a single pad. At 800 kHz, the impedance of the glass drops to 200 kΩ or lower giving a ratio of a greater than 5 to 1 impedance difference between the paths to ground of the touched pad 57 and adjacent pads 59. In fact, the impedance ratio may exceed 10 to 1, as illustrated in the calculation below. This allows the detection threshold for the touched pad to be set well below that of an adjacent pad resulting in a much lower incidence of inadvertent actuation of adjacent touch pads to that of the touched pad. Col. 10:54 – Col. 11:9.</p> <p>The `183 Patent discloses “As stated above, the operator’s body includes a capacitance to ground, which may range in a typical person from between 20 to 300 pF. The base terminal of transistor 410 is coupled to it’s [sic] emitter by resistor 412 such that unless capacitance is present by the user touching the touch pad 450, transistor 410 will not be forward biased and will not conduct. Thus, when touch pad 450 is not touched, the output signal at the collector terminal of transistor 410 and across pulse stretcher circuit 417 will be zero volts. When, however, a person touches the touch pad 450, that person’s body capacitance to ground couples the base of transistor 410 to ground 103 through resistor 413, thereby forward biasing transistor 410 into conduction. This charges capacitor 418 providing a positive DC voltage with respect to the line 301 and causes the output of the Schmitt trigger 420 to go low. Diode 414 is coupled across the base to emitter junction of transistor 410 to clamp the base emitter reverse bias</p>

`183 Patent Claim Language	`183 Patent Support
	voltage to -0.7V and also reduce the forward recovery and turn-on time. Col. 15:29-47.

UUU. New Claim 110

`183 Patent Claim Language	`183 Patent Support
<p>110. The capacitive responsive electronic switching circuit as defined in claim 106, wherein the detector circuit comprises a plurality of touch circuits, and wherein the microcontroller selectively provides the signal output frequencies to the plurality of small sized input touch terminals of the keypad via the plurality of touch circuits.</p>	<p>See Figures 4 and 11; Claims 6, 18.</p> <p>Microcontroller 500 selects each row of the touch circuits 900₁ to 900_{nm} by providing the signal from oscillator 200 to selected rows of touch circuits. In this manner, microcontroller 500 can sequentially activate the touch circuit rows and associate the received inputs from the columns of the array with the activated touch circuit(s). To keep the path length 451 between the touch pad 450 and the base to the detection transistor 410 to a minimum, the detection circuits 900 are physically located directly beneath the touch pads. Col. 18:43-52.</p>

VVV. New Claim 111

For ease of analysis, new independent claim 111 is shown below with pseudo-amendments illustrating the differences between new claim 111 and claim 27 of the `183 Patent following the first reexamination proceeding.

`183 Patent Claim Language	`183 Patent Support
<p>111. A capacitive responsive electronic switching circuit for a controlled keypad device comprising:</p>	<p>See Claim 27.</p>
<p>an oscillator providing a periodic output signal having a predefined frequency;</p>	<p>See Claim 27.</p>
<p>a microcontroller using the periodic output signal from the oscillator, the microcontroller selectively providing signal output frequencies to a closely spaced array of input touch terminals of a keypad, the input touch terminals</p>	<p>See Figures 4, 11; and Claims 8, 12, 16, 27.</p> <p>The `183 Patent discloses “The touch detection circuit of the present invention features operation at frequencies at or above 50 kHz and preferably at or above 800 kHz to minimize the effects of</p>

`183 Patent Claim Language	`183 Patent Support
<p>comprising first and second input touch terminals, wherein the selectively providing comprises the microcontroller selectively providing a signal output frequency to each row of the closely spaced array of input touch terminals of the keypad;</p>	<p>surface contamination from materials such a [sic] skin oils and water. It also offers improvements in detection sensitivity that allow close control of the degree of proximity (ideally very close proximity) that is required for actuation and to enable employment of a multiplicity of small sized touch terminals in a physically close array such as a keyboard.” Col. 5:49-57.</p> <p>The `183 Patent discloses “In a first preferred embodiment the circuit offers enhanced detection sensitivity to allow reliable operation with small (finger size) touch pads.” Col. 6:1-3.</p> <p>The `183 Patent discloses “Although the preferred frequency is at or above 100 kHz, and more preferably at or above 800 kHz, it is conceivable that frequencies as low as 50 kHz could be used provided the frequency creates a difference in the impedance paths of adjacent pads that is sufficient enough to accurately distinguish between an intended touch and the touch of an adjacent pad. Use of frequencies as low as 50 kHz may also be possible depending upon the type of glass or covering or the thickness thereof used for the touch pad.” Col. 11:19-27.</p> <p>The `183 Patent discloses “Upon being powered by voltage regulator 100, oscillator 200 generates a square wave with a frequency of 50 kHz, and preferably greater than 800 kHz, and having an amplitude of 26 V peak. The square wave generated by oscillator 200 is supplied via line 201 to a floating common generator 300, a touch pad shield plate 460, a touch circuit 400, and a microcontroller 500. Oscillator 200 is described below with reference to FIG. 6. Floating common generator 300 receives the 26 V peak square wave from oscillator 200 and outputs a regulated floating common that is 5 volts below the square wave output from oscillator 200 and has the same phase and</p>

`183 Patent Claim Language	`183 Patent Support
	<p>frequency as the received square wave. This floating common output is supplied to touch circuit 400 and microcontroller 500 via line 301 such that the output square wave from oscillator 200 and floating common output from floating common generator 300 provide power to touch circuit 400 and microcontroller 500. Details of floating common generator 300 are discussed below with reference to FIG. 7.</p> <p>Touch circuit 400 senses capacitance from a touch pad 450 via line 451 and outputs a signal to microcontroller 500 via line 401 upon detecting a capacitance to ground at touch pad 450 that exceeds a threshold value. The details of touch circuit 400 are described below with reference to FIG. 8.</p> <p>Upon receiving an indication from touch circuit 400 that a sufficient capacitance to ground (typically at least 20 pF) is present at touch pad 450, microcontroller 500 outputs a signal to a load-controlling microcontroller 600 via line 501, which is preferably a two way optical coupling bus.” Col. 12:6-33.</p> <p>The `183 Patent discloses “As will be apparent to those skilled in the art, the values of the resistors and capacitors utilized in oscillator 200 may be varied from those disclosed above to provide for different oscillator output frequencies.” Col. 14:22-25.</p> <p>The `183 Patent discloses “A multiple touch pad circuit constructed in accordance with the second embodiment is shown in FIG. 11. In the second embodiment of FIG. 11, components similar to those in the first embodiment in FIG. 4 are designated with the same references numerals and will not be discussed in detail.</p> <p>The multiple touch pad circuit is a variation of the first embodiment in that it includes an array of touch circuits designated as 900₁ through 900_{nm}, which, as shown, include both the touch circuit 400 shown in FIGS. 4 and 8 and the input touch terminal pad 451 (FIG. 4).</p>

`183 Patent Claim Language	`183 Patent Support
	<p>Microcontroller 500 selects each row of the touch circuits 900₁ to 900_{nm} by providing the signal from oscillator 200 to selected rows of touch circuits. In this manner, microcontroller 500 can sequentially activate the touch circuit rows and associate the received inputs from the columns of the array with the activated touch circuit(s). To keep the path length 451 between the touch pad 450 and the base to the detection transistor 410 to a minimum, the detection circuits 900 are physically located directly beneath the touch pads. To simplify assembly, a flexible circuit board such as vended by Sheldahl, Inc. or Circuit Etching Technics, Inc. can be used for this purpose. Ideally, the printed circuit will be fixed directly against the surface (typically glass) bearing the conductive touch pads to eliminate air gaps and the need for conductive foam pads and spring contacts which were used to fill air gaps.” Col. 18:34-59.</p>
<p>the first and second input touch terminals defining areas for an operator to provide an input by proximity and touch; and</p>	<p>See Claim 27.</p>
<p>a detector circuit coupled to said oscillator for receiving said periodic output signal from said oscillator, and coupled to said first and second touch terminals, said detector circuit being responsive to signals from said oscillator via said microcontroller and a presence of an operator's body capacitance to ground coupled to said first and second touch terminals when proximal or touched by the operator to provide a control output signal for actuation of the controlled keypad device, said detector circuit being configured to generate said control output signal when the operator is proximal or touches said second touch terminal after the operator is proximal or touches said first touch terminal.</p>	<p>See Claim 27.</p>

WWW. New Claim 112

`183 Patent Claim Language	`183 Patent Support
112. The capacitive responsive electronic switching circuit as defined in claim 111, wherein said first and second touch terminals are adapted to be mounted on different surfaces of the controlled keypad device.	See Claim 29.

XXX. New Claim 113

`183 Patent Claim Language	`183 Patent Support
113. The capacitive responsive electronic switching circuit as defined in claim 111, wherein said first and second touch terminals are adapted to be mounted on non-parallel planar surfaces of the controlled keypad device.	See Claim 30.

YYY. New Claim 114

`183 Patent Claim Language	`183 Patent Support
114. The capacitive responsive electronic switching circuit as defined in claim 111, wherein said first and second touch terminals are adapted to be mounted on perpendicular planar surfaces of the controlled keypad device.	See Claim 31.

ZZZ. New Claim 115

`183 Patent Claim Language	`183 Patent Support
115. The capacitive responsive electronic switching circuit as defined in	See Claim 32.

`183 Patent Claim Language	`183 Patent Support
claim 111 and further including an indicator for indicating when said detector circuit determines that the operator is proximal or touches said first touch terminal.	

AAAA. New Claim 116

`183 Patent Claim Language	`183 Patent Support
116. The capacitive responsive electronic switching circuit as defined in claim 111 and further including an indicator for indicating when said detector circuit determines that the operator is proximal or touches said second touch terminal.	<p>See Claims 32 and 36.</p> <p>The `183 Patent discloses “The microprocessor also allows the use of visual indicators such as LEDs or annunciators such as a bell or tone generator to confirm the actuation of a given touch switch or switches. This is particularly useful in cases where a sequence of actuations is required before an action occurs. The feedback to the operator provided by a visual or audio indicator activated by the microprocessor in response to intermediate touches in a required sequence can minimize time lost and/or frustration on the part of the operator due to failed actuations from partial touches or wrong actuations from touching the wrong pad in a given required sequence or combination of touches.” Col. 6:31-42.</p> <p>The `183 Patent discloses “A further option is to provide one or more LEDs 2205 or audible annunciators for visual or audible feedback to the operator. Specifically, in FIG. 19 the LED 2205 will come on when button 2201 has been successfully activated to cue the operator that it is time to move to button 2202. Where required a second LED with a different color than the first (yellow for the first LED and red for the second) can be provided to provide visual confirmation that the second button 2202 has been activated or that the required combination of the two buttons has been activated. Two different audible tone</p>

`183 Patent Claim Language	`183 Patent Support
	<p>or sound generators could also be used in lieu of the LEDs to provide feedback to the operator.” Col. 23:1-12.</p> <p>The `183 Patent discloses “A red LED 2305 on top of the device shows the completion of the two step tum-on and activation of output relay 2310.” Col. 23:28-30.</p>

BBBB. New Claim 117

`183 Patent Claim Language	`183 Patent Support
<p>117. The capacitive responsive electronic switching circuit as defined in claim 111, wherein the detector circuit comprises a plurality of touch circuits, and wherein the microcontroller selectively provides the signal output frequencies to the closely spaced array of input touch terminals of the keypad via the plurality of touch circuits.</p>	<p>See Figures 4 and 11; Claims 6, 27.</p> <p>Microcontroller 500 selects each row of the touch circuits 900₁ to 900_{nm} by providing the signal from oscillator 200 to selected rows of touch circuits. In this manner, microcontroller 500 can sequentially activate the touch circuit rows and associate the received inputs from the columns of the array with the activated touch circuit(s). To keep the path length 451 between the touch pad 450 and the base to the detection transistor 410 to a minimum, the detection circuits 900 are physically located directly beneath the touch pads. Col. 18:43-52.</p>

I. CONCLUSION

In view of the above, the Patent Owner submits that the claims are in condition for allowance. The present amendment neither enlarges the scope of the claims of the patent nor introduces new matter. If the Examiner should have any questions, please contact the Patent Owner's Attorney, Brian A. Carlson, at 972-732-1001. The Commissioner is hereby authorized to charge any fees due in connection with this filing, or credit any overpayment, to Deposit Account No. 50-1065.

Respectfully submitted,

May 7, 2014
Date

/Brian A. Carlson/
Brian A. Carlson
Reg. No. 37,793

Slater & Matsil, L.L.P.
17950 Preston Rd.
Suite 1000
Dallas, TX 75252
972-732-1001
972-732-9218 (fax)

Electronic Patent Application Fee Transmittal

Application Number:	90013106				
Filing Date:	24-Dec-2013				
Title of Invention:	Capacitive Responsive Electronic Switching Circuit				
First Named Inventor/Applicant Name:	5796183				
Filer:	Brian A. Carlson/Michelle Hatcher				
Attorney Docket Number:	NAR-5796183RX2				
Filed as Large Entity					
ex parte reexam Filing Fees					
Description	Fee Code	Quantity	Amount	Sub-Total in USD(\$)	
Basic Filing:					
Pages:					
Claims:					
Reexamination claims in excess of 20	1822	10	80	800	
Miscellaneous-Filing:					
Petition:					
Patent-Appeals-and-Interference:					
Post-Allowance-and-Post-Issuance:					
Extension-of-Time:					

Description	Fee Code	Quantity	Amount	Sub-Total in USD(\$)
Miscellaneous:				
Total in USD (\$)				800

Electronic Acknowledgement Receipt

EFS ID:	18972281
Application Number:	90013106
International Application Number:	
Confirmation Number:	9188
Title of Invention:	Capacitive Responsive Electronic Switching Circuit
First Named Inventor/Applicant Name:	5796183
Customer Number:	25962
Filer:	Brian A. Carlson/Michelle Hatcher
Filer Authorized By:	Brian A. Carlson
Attorney Docket Number:	NAR-5796183RX2
Receipt Date:	07-MAY-2014
Filing Date:	24-DEC-2013
Time Stamp:	18:11:47
Application Type:	Reexam (Patent Owner)

Payment information:

Submitted with Payment	yes
Payment Type	Deposit Account
Payment was successfully received in RAM	\$800
RAM confirmation Number	4565
Deposit Account	501065
Authorized User	

The Director of the USPTO is hereby authorized to charge indicated fees and credit any overpayment as follows:
 Charge any Additional Fees required under 37 C.F.R. Section 1.16 (National application filing, search, and examination fees)
 Charge any Additional Fees required under 37 C.F.R. Section 1.17 (Patent application and reexamination processing fees)

File Listing:					
Document Number	Document Description	File Name	File Size(Bytes)/ Message Digest	Multi Part /.zip	Pages (if appl.)
1		NAR_5796183RX_ResponseTo OfficeAction.pdf	595176 <small>cd065ed1b6eda4b303e75f27de8f369062fd5cc52</small>	yes	141
Multipart Description/PDF files in .zip description					
		Document Description	Start	End	
		Response after non-final action-owner timely	1	1	
		Claims	2	14	
		Applicant Arguments/Remarks Made in an Amendment	15	141	
Warnings:					
Information:					
2	Fee Worksheet (SB06)	fee-info.pdf	30097 <small>afa5124608e57e6f6709f2fa7861b4c38d2e117d</small>	no	2
Warnings:					
Information:					
Total Files Size (in bytes):			625273		
<p>This Acknowledgement Receipt evidences receipt on the noted date by the USPTO of the indicated documents, characterized by the applicant, and including page counts, where applicable. It serves as evidence of receipt similar to a Post Card, as described in MPEP 503.</p> <p><u>New Applications Under 35 U.S.C. 111</u> If a new application is being filed and the application includes the necessary components for a filing date (see 37 CFR 1.53(b)-(d) and MPEP 506), a Filing Receipt (37 CFR 1.54) will be issued in due course and the date shown on this Acknowledgement Receipt will establish the filing date of the application.</p> <p><u>National Stage of an International Application under 35 U.S.C. 371</u> If a timely submission to enter the national stage of an international application is compliant with the conditions of 35 U.S.C. 371 and other applicable requirements a Form PCT/DO/EO/903 indicating acceptance of the application as a national stage submission under 35 U.S.C. 371 will be issued in addition to the Filing Receipt, in due course.</p> <p><u>New International Application Filed with the USPTO as a Receiving Office</u> If a new international application is being filed and the international application includes the necessary components for an international filing date (see PCT Article 11 and MPEP 1810), a Notification of the International Application Number and of the International Filing Date (Form PCT/RO/105) will be issued in due course, subject to prescriptions concerning national security, and the date shown on this Acknowledgement Receipt will establish the international filing date of the application.</p>					



UNITED STATES PATENT AND TRADEMARK OFFICE

UNITED STATES DEPARTMENT OF COMMERCE
United States Patent and Trademark Office
Address: COMMISSIONER FOR PATENTS
P.O. Box 1450
Alexandria, Virginia 22313-1450
www.uspto.gov

APPLICATION NO.	FILING DATE	FIRST NAMED INVENTOR	ATTORNEY DOCKET NO.	CONFIRMATION NO.
-----------------	-------------	----------------------	---------------------	------------------

90/013,106	12/24/2013	5796183	NAR-5796183RX2	9188
------------	------------	---------	----------------	------

25962 7590 03/27/2014
 SLATER & MATSIL, L.L.P.
 17950 PRESTON RD, SUITE 1000
 DALLAS, TX 75252-5793

EXAMINER

TRAN, HENRY N

ART UNIT	PAPER NUMBER
----------	--------------

3992

MAIL DATE	DELIVERY MODE
-----------	---------------

03/27/2014

PAPER

Please find below and/or attached an Office communication concerning this application or proceeding.

The time period for reply, if any, is set in the attached communication.

Office Action in Ex Parte Reexamination	Control No. 90/013,106	Patent Under Reexamination 5796183	
	Examiner HENRY N. TRAN	Art Unit 3992	AIA (First Inventor to File) Status No

-- The MAILING DATE of this communication appears on the cover sheet with the correspondence address --

- a. Responsive to the communication(s) filed on 12/24/2013.
 A declaration(s)/affidavit(s) under **37 CFR 1.130(b)** was/were filed on _____.
- b. This action is made FINAL.
- c. A statement under 37 CFR 1.530 has not been received from the patent owner.

A shortened statutory period for response to this action is set to expire 2 month(s) from the mailing date of this letter. Failure to respond within the period for response will result in termination of the proceeding and issuance of an *ex parte* reexamination certificate in accordance with this action. 37 CFR 1.550(d). **EXTENSIONS OF TIME ARE GOVERNED BY 37 CFR 1.550(c)**. If the period for response specified above is less than thirty (30) days, a response within the statutory minimum of thirty (30) days will be considered timely.

Part I THE FOLLOWING ATTACHMENT(S) ARE PART OF THIS ACTION:

- | | |
|---|---|
| 1. <input type="checkbox"/> Notice of References Cited by Examiner, PTO-892. | 3. <input type="checkbox"/> Interview Summary, PTO-474. |
| 2. <input checked="" type="checkbox"/> Information Disclosure Statement, PTO/SB/08. | 4. <input type="checkbox"/> _____. |

Part II SUMMARY OF ACTION

- 1a. Claims 18,27 and 40-105 are subject to reexamination.
- 1b. Claims 1-17,19-26,28-34 and 36-39 are not subject to reexamination.
2. Claims 35 have been canceled in the present reexamination proceeding.
3. Claims 45-55 and 72-94 are patentable and/or confirmed.
4. Claims 18,27,40-44, 56-71 and 95-105 are rejected.
5. Claims _____ are objected to.
6. The drawings, filed on _____ are acceptable.
7. The proposed drawing correction, filed on _____ has been (7a) approved (7b) disapproved.
8. Acknowledgment is made of the priority claim under 35 U.S.C. § 119(a)-(d) or (f).
a) All b) Some* c) None of the certified copies have
1 been received.
2 not been received.
3 been filed in Application No. _____ .
4 been filed in reexamination Control No. _____ .
5 been received by the International Bureau in PCT application No. _____ .
* See the attached detailed Office action for a list of the certified copies not received.
9. Since the proceeding appears to be in condition for issuance of an *ex parte* reexamination certificate except for formal matters, prosecution as to the merits is closed in accordance with the practice under *Ex parte* Quayle, 1935 C.D. 11, 453 O.G. 213.
10. Other: _____

cc: Requester (if third party requester)

The present application is being examined under the pre-AIA first to invent provisions.

DETAILED EX PARTE REEXAMINATION NON-FINAL ACTION

I. INTRODUCTION

1. This Non-Final Office action concerns the *Ex Parte* Reexamination of the U.S. Patent No. 5,796,183 C1 issued April 29, 2013 to Hourmand et al. (the '183 patent or "Hourmand"). Patent Owner's waiver of its statement under 37 CFR 1.530 filed on March 4, 2014 after the Order Granting Request for *Ex Parte* Reexamination of claims 18 and 27 of the '183 patent mailed on February 26, 2014. Patent owner's Amendment under rule 37 CFR 1.510 filed with the Request on December 24, 2013 has been entered. Claims 18, 27, and 40-105 are considered in this reexamination proceeding. The examination results are: Claims 18, 27, 40-44, 56-71, and 95-105 are rejected; and claims 45-55 and 72-94 are found patentable because of the reasons set forth below.

II. RULES, REGULATIONS AND REEXAMINATION PROCEDURE

2. The following rules and procedures are applicable to this action:

35 U.S.C. 305 Conduct of reexamination proceedings.

After the times for filing the statement and reply provided for by section 304 of this title have expired, reexamination will be conducted according to the procedures established for initial examination under the provisions of sections 132 and 133 of this title. In any reexamination proceeding under this chapter, the patent owner will be permitted to propose any amendment to his patent and a new claim or claims thereto, in order to distinguish the invention as claimed from the prior art cited under the provisions of section 301 of this title, or in response to a decision adverse to the patentability of a claim of a patent. No proposed amended or new claim enlarging the scope of a claim of the patent will be permitted in a reexamination proceeding under this chapter. All reexamination proceedings under this section, including any appeal to the

Art Unit: 3992

Board of Patent Appeals and Interferences, will be conducted with special dispatch within the Office.

37 C.F.R. 1.552 Scope of reexamination in ex parte reexamination proceedings.

- (a) Claims in an *ex parte* reexamination proceeding will be examined on the basis of patents or printed publications and, with respect to subject matter added or deleted in the reexamination proceeding, on the basis of the requirements of 35 U.S.C. **112**.
- (b) Claims in an *ex parte* reexamination proceeding will not be permitted to enlarge the scope of the claims of the patent.
- (c) Issues other than those indicated in paragraphs (a) and (b) of this section will not be resolved in a reexamination proceeding. If such issues are raised by the patent owner or third party requester during a reexamination proceeding, the existence of such issues will be noted by the examiner in the next Office action, in which case the patent owner may consider the advisability of filing a reissue application to have such issues considered and resolved.

The reexamination proceeding provides a complete reexamination of the patent claims on the basis of prior art patents and printed publications. Issues relating to **35 U.S.C. 112** are addressed only with respect to new claims or amendatory subject matter in the specification, claims or drawings. Any new or amended claims are examined to ensure that the scope of the original patent claims is not enlarged, i.e., broadened. See **35 U.S.C. 305**.

See MPEP 2258

MPEP 2260.01 Dependent Claims [R-2] provides:

If ** > an unamended base patent claim (i.e., a claim appearing in the reexamination as it appears in the patent) < has been rejected or canceled, any claim which is directly or indirectly dependent thereon should be confirmed or allowed if the dependent claim is otherwise allowable. The dependent claim should *not* be objected to or rejected merely because it depends on a rejected or canceled patent claim. No requirement should be made for rewriting the dependent claim in independent form. As the original patent claim numbers are not changed in a reexamination proceeding, the content of the canceled base claim would remain in the printed patent and would be available to be read as a part of the confirmed or allowed dependent claim.

If a new base claim (a base claim other than a base claim appearing in the patent) has been canceled in a reexamination proceeding, a claim which depends thereon should be rejected as * > indefinite < . If a new base claim > or an amended patent claim < is rejected, a claim dependent thereon should be objected to if it is otherwise patentable and a requirement made for rewriting the dependent claim in independent form

III. PRIOR ART PATENTS AND PRINTED PUBLICATIONS

3. The prior art patents and printed publications cited in the request pursuant to C.F.R. § 1.510(b) (3), see *id.*, Request page 10, and relied upon in this Office action are relisted below:

- U.S. Patent No. 5,463,388 issued to Boie et al. on October 31, 1995 ("Boie" or the '388 patent), which was submitted with the request as Exhibit C.
- U.S. Patent No. 5,565,658 issued to Gerpheide et al. on October 15, 1996 ("Gerpheide" or the '658 patent), which was submitted with the request as Exhibit D.
- Casio advertisement entitled "Now... The Invisible Casio Calculator Watch," published in Popular Science by On the Run in 1984 ("Casio"), which was submitted with the request as Exhibit E.
- Lee, thesis entitled "A Fast Multiple-Touch-Sensitive Input Device," and published October 1984 ("Lee"), which was submitted with the IDS filed with the request.

4. Boie filed on January 29, 1993, Gerpheide filed on December 7, 1994, Casio published in 1984, and Lee published in October 1984; and they are all prior to the Critical Date of January 31, 1996 - which is the filing date of the '183 patent - constitute effective prior art reference as to the claims of the '183 patent under 35 U.S.C. §102(a), 102(e), or 102(b).

It is noted that Boie was previously cited and considered, i.e., "old art", by the Office in an earlier concluded *ex parte* reexamination control number 90/012,439 of the patent being reexamined, which is hereinafter referred to as "the first request"; and Lee was newly cited with the Amendment and its content and pertinent information thereof as explained by the patent owner have been noted.

IV. RESPONSE TO AMENDMENT

Patent owner's Amendment under 37 CFR 1.510 filed on December 24, 2013 has been entered. Patent owner's amendments to the claims and the remarks, see *id.* Amendment pp. 2-142, with respect to the claims status, claims support, and prior art references have been fully considered with the results set forth below.

5. Regarding the status of the claims

(Amendment Section II page 17)

Claims 18 and 27 have been amended, claims 40-105 are new, claim 35 is canceled, and claims 1-17, 19-26, 28-34, and 36-39 are original and they have not been requested for reexamination; thus, claims 18, 27, and 40-105 are considered in this reexamination proceeding.

It is noted that claims 18 and 27 each has dependent claims (i.e., claims 19, 33, and 34, or 28-32, and 36, respectively) that are not subject to reexamination. Because the effect that they would have on the scope of claims that are not subject to reexamination, no amendments to any of these claims that would change the scope of each respective claim may be made, unless all claims that are dependent upon the claim are also made subject to this reexamination proceeding.

In order to make the dependent claims subject to reexamination, the patent holder should submit for each such dependent claim:

(a) a statement pointing out at least one substantial new question of patentability based on the prior patents and printed publications of record as to the dependent claim, and

(b) a detailed explanation of the pertinency and manner of applying the prior art patents and printed publications of record to that dependent claim.

As an alternative, the patent holder may submit new claims that consist of the same limitations as the original parent claims, with any desired amendments to the claims being made to those new claims; and the patent holder may also choose to amend any other claims that are subject to reexamination so that they are properly dependent upon these new claims, as appropriate. In this case, claims 18 and 27 should be canceled and have them rewritten into two new claims; also, new claims 40-44 and 66-71 should be amended, where applicable, to reflect the dependency to the two new claims; and non-reexamined dependent claims 19, 28-34, and 36 are not changed (see MPEP 2260.01 recited above).

Appropriate correction is required.

6. Regarding Patent owner's discussion of claims and prior art references

(a) Regarding Lee

Patent owner's arguments, see Amendment pp. 18-20, with respect to the teachings of the Lee's system and method of A Fast Multiple-Touch-Sensitive Input Device, has been fully considered and are persuasive. The examiner agrees that Lee does not disclose sending signal output frequencies to the selected rows.

(b) Regarding Claims 18, 27, 40-44, and 66-71

Patent owner's arguments, see *id.* at Amendment pp. 21-24, with respect to the combinations of prior art references, Boie, Gerpheide, Lee, and/or Casio, for the rejections of independent claims 18 and 27, and their dependent claims 40-44, and 66-71, respectively, have been fully considered but they are not persuasive because the discussion is directed to the issues and/or limitations that enlarge the scope of the claims of the '183 patent. Such issues may be considered and resolved in a reissue application. See 37 C.F.R. 1.552(c). It is noted that claims 18, 27, 40-44, and 66-71 are rejected under 35 U.S.C. 305 (see the rejections under 35 U.S.C. 305 below).

(c) Regarding Claims 45-55

Patent owner's arguments, see *id.* at Amendment pp. 24-26, with respect to claims 45-55, have been fully considered and are persuasive. The examiner agrees that Boie in combination with Gerpheide and/or Lee does not disclose at least all the limitations of base claim 45. Claims 45-55 are patentable.

(d) Regarding Claims 56-65

Patent owner's arguments, see *id.* at Amendment p. 26, with respect to the combinations of prior art references, Boie, Gerpheide, and/or Lee, for the rejections of independent claim 56 and its dependent claims 57-65, have been fully considered but they are not persuasive because the discussion is directed to the issues and/or limitations that enlarge the scope of the claims of the '183 patent. As noted in claims 18 and 27 above, such issues may be considered and resolved in a reissue application. See 37 C.F.R. 1.552(c). It is noted that claims 56-65 are rejected under 35 U.S.C. 305 (see the rejections under 35 U.S.C. 305 below).

(e) Regarding Claims 72-83

Patent owner's arguments, see *id.* at Amendment pp. 27-28, with respect to claims 72-83, have been fully considered and are persuasive. The examiner agrees that Boie in combination with Gerpheide, Lee and/or Casio does not disclose at least all the limitations of base claim 72.

Claims 72-83 are patentable.

(f) Regarding Claims 84-94

Patent owner's arguments, see *id.* at Amendment pp. 28-29, with respect to claims 84-94, have been fully considered and are persuasive. The examiner agrees that Boie in combination with Gerpheide, Lee and/or Casio does not disclose at least all the limitations of base claim 84.

Claims 84-94 are patentable.

(g) Regarding Claims 95-105

Patent owner's arguments, see *id.* at Amendment pp. 29-30, with respect to the combinations of prior art references, Boie, Gerpheide, Casio and/or Lee, for the rejections of independent claim 95 and its dependent claims 96-105, have been fully considered but they are not persuasive because the discussion is directed to the issues and/or limitations that enlarge the scope of the claims of the '183 patent. As noted in claims 18 and 27 above, such issues may be considered and resolved in a reissue application. See 37 C.F.R. 1.552(c). It is noted that claims 95-105 are rejected under 35 U.S.C. 305 (see the rejections under 35 U.S.C. 305 below).

V. RELEVANT STATUTE - CLAIMS REJECTIONS

7. Relevant Statute

35 U.S.C. 305 Conduct of reexamination proceedings

After the times for filing the statement and reply provided for by section 304 of this title have expired, reexamination will be conducted according to the procedures established for initial examination under the provisions of sections 132 and 133 of this title. In any reexamination proceeding under this chapter, the patent owner will be permitted to propose any amendment to his patent and a new claim or claims thereto, in order to distinguish the invention as claimed from the prior art cited under the provisions of section 301 of this title, or in response to a decision adverse to the patentability of a claim of a patent. No proposed amended or new claim enlarging the scope of a claim of the patent will be permitted in a reexamination proceeding under this chapter. All reexamination proceedings under this section, including any appeal to the Board of Patent Appeals and Interferences, will be conducted with special dispatch within the Office.

8. Claim Rejections

(a) Claim Rejections - 35 U.S.C. 305

Claims 18, 27, 40-44, 56-71, and 95-105 are rejected under 35 U.S.C. 305 as enlarging the scope of the claims 18 and 27 of the patent being reexamined. In 35 U.S.C. 305, it is stated that “[n]o proposed amended or new claim enlarging the scope of a claim of the patent will be permitted in a reexamination proceeding... .” A claim presented in a reexamination “enlarges the scope” of the patent claim(s) where the claim is broader than any claim of the patent. A claim is

broader in scope than the original claims if it contains within its scope any conceivable product or process which would not have infringed the original patent. A claim is broadened if it is broader in any one respect, even though it may be narrower in other respects.

Regarding amended base claim 18, the limitation: “the microcontroller selectively providing signal output frequencies, wherein a signal output frequency is selectively provided to each row of a plurality of small sized input touch terminals of a keypad;” recited in lines 3-5 enlarges the scope of the original patent claim 18 because it is different from the term “the microcontroller selectively providing signal output frequencies to a plurality of small sized input touch terminals of a keypad;” recited in lines 6-8 of the original base patent claim 18. The scope of patent claim 18 has been redefined and enlarged by said limitation in at least one respect. Specifically, the microcontroller is no longer being required to selectively provide signal output frequencies to a plurality of small sized input touch terminals of a keypad as compared with that of the original base patent claim 18; and thus, the claim is broader in scope in this respect. Claim 18 is therefore rejected.

Regarding new claims 40-44, which are dependent upon the amended base claim 18, and they are rejected on the same reason set forth for the amended base claim 18 above due to their dependency.

Regarding amended base claim 27, the limitation: “the microcontroller selectively providing signal output frequencies, wherein a signal output frequency is selectively provided to each row of a closely spaced array of input touch terminals of a keypad, the input touch terminals comprising first and second input touch terminals;” recited in lines 4-7 enlarges the scope of the original patent claim 27 because it is different from the term “the microcontroller selectively

providing signal output frequencies to a closely spaced array of input touch terminals of a keypad, the input touch terminals comprising first and second input touch terminals;” recited in lines 6-9 of the original base patent claim 27. The scope of patent claim 27 has been redefined and enlarged by said limitation in at least one respect. Specifically, the microcontroller is no longer being required to selectively provide signal output frequencies to a closely spaced array of input touch terminals of a keypad as compared with that of the original base patent claim 27; and thus, the claim is broader in scope in this respect. Claim 27 is therefore rejected.

Regarding new claims 66-71, which are dependent upon the amended base claim 27, and they are rejected on the same reason set forth for the amended base claim 27 above due to their dependency.

Regarding new claims 56-65, each recites the limitation: “the microcontroller selectively providing signal output frequencies, wherein a signal output frequency is selectively provided to each row of a plurality of small sized input touch terminals of a keypad;” in lines 3-5 of base claim 56, and which has been found to enlarge the scope of the ‘183 patent claim 18 (see the discussion for claim 18 above). Claim 56-65 are therefore rejected.

Regarding new claims 95-105, each recites the limitation: “the microcontroller selectively providing signal output frequencies, wherein a signal output frequency is selectively provided to each row of a closely spaced array of input touch terminals of a keypad, the input touch terminals comprising first and second input touch terminals;” in lines 4-7, and which has been found to enlarge the scope of the ‘183 patent claim 27 (see the discussion for claim 27 above). Claim 95-105 are therefore rejected.

VI. ALLOWABLE SUBJECT MATTER

9. Claims 45-55 and 72-94 are allowed.

STATEMENT OF REASONS FOR PATENTABILITY AND/OR CONFIRMATION

10. The following is an examiner's statement of reasons for patentability and/or confirmation of the claims found patentable in this reexamination proceeding:

The '183 patent generally relates to a capacitive responsive electronic switching circuit including an oscillator **200** providing a periodic output signal, a keypad having a plurality of input touch terminals **450** defining areas for an operator to provide inputs by proximity and touch, a microcontroller **500** using the periodic output signal from the oscillator for selectively providing signal output frequencies to the input touch terminals, and a detector circuit **400** coupled to the oscillator, the input touch terminals, and the microcontroller for providing a control output signal based on the presence of operator's body capacitance to ground coupled to the input touch terminal when in proximity or touched by an operator. See, e.g., the '183 patent, Abstract, Figures 4 and 11. Each of the independent claims 45, 72 and 84 identifies the uniquely distinct features that are not taught or suggested by the cited prior art patents and publications, either alone or in any reasonable combinations. Specifically,

(i) Independent claim 45 requires, *inter alia*, the features: "an oscillator (200) providing a periodic output signal having a predefined frequency;", "the microcontroller (500) selectively providing signal output frequencies directly to a plurality of small sized input touch terminals (57, 59) of a keypad", and "a detector circuit (400) coupled to said oscillator (200) for receiving said periodic output signal from said oscillator, and coupled to said input touch terminals, said

Art Unit: 3992

detector circuit being responsive to signals from said oscillator via said microcontroller and a presence of an operator's body capacitance (CBODY) to ground coupled to said touch terminals when proximal or touched by the operator to provide a control output signal, wherein said predefined frequency of said oscillator and said signal output frequencies are selected to decrease a first impedance of said dielectric substrate relative to a second impedance of any contaminate that may create an electrical path on said dielectric substrate between said adjacent areas defined by the plurality of small sized input touch terminals, and wherein said detector circuit compares a sensed body capacitance change to ground proximate an input touch terminal to a threshold level to prevent inadvertent generation of the control output signal.", see Figures 3 and 4;

(ii) Independent claim 72 requires, *inter alia*, the features: "an oscillator (200) providing a periodic output signal having a predefined frequency;", "a microcontroller (500) using the periodic output signal from the oscillator, the microcontroller selectively providing signal output frequencies directly to a closely spaced array of input touch terminals (57, 59) of a keypad;", and "a detector circuit (400) coupled to said oscillator for receiving said periodic output signal from said oscillator, and coupled to said first and second touch terminals (57, 59), said detector circuit being responsive to signals from said oscillator via said microcontroller and a presence of an operator's body capacitance (CBODY) to ground coupled to said first and second touch terminals when proximal or touched by the operator to provide a control output signal for actuation of the controlled keypad device, said detector circuit being configured to generate said control output signal when the operator is proximal or touches said second touch terminal after the operator is proximal or touches said first touch terminal." , see Figures 3 and 4; and

Art Unit: 3992

(iii) independent claim 84 requires, *inter alia*, the features: “an oscillator (200) providing a periodic output signal having a predefined frequency;”, “a microcontroller(500) using the periodic output signal from the oscillator, the microcontroller selectively providing signal output frequencies to a closely spaced array of input touch terminals (57, 59) of a keypad, the input touch terminals comprising first and second input touch terminals (57, 59), wherein a peak voltage of the signal output frequencies is greater than a supply voltage;”, and “a detector circuit coupled to said oscillator for receiving said periodic output signal from said oscillator, and coupled to said first and second touch terminals, said detector circuit being responsive to signals from said oscillator via said microcontroller and a presence of an operator's body capacitance to ground coupled to said first and second touch terminals when proximal or touched by the operator to provide a control output signal for actuation of the controlled keypad device, said detector circuit being configured to generate said control output signal when the operator is proximal or touches said second touch terminal after the operator is proximal or touches said first touch terminal.”, see Figures 3 and 4

Whereas, the cited prior art:

Boie

Boie discloses a computer input device for use as a computer mouse or keyboard comprises a thin, insulating surface covering an array **100** of electrodes arranged in a grid pattern and connected in columns and rows, each column and row is connected to circuitry **401**, which can be selected by multiplexer **402** under control of microcontroller 406. See *id.* at col. 3:56-61. The selected output is forwarded to summing circuit **403**, the output of which is converted by synchronous detector and filter circuit **404** to a signal related to the capacitance of the row or column selected by the multiplexer. See *id.* at col. 3:62-67. The RF oscillator **408** provides an RF signal of, for example ,100 Kilohertz, to circuits **401**, synchronous detector and filter circuit **404** via inverter **410**, and guard plane **411**, which is a substantially continuous plane parallel to array **100** and associated connections, and serves to isolate array **100** from extraneous signals. See *id.* at col. 3:67 - col. 4:5. To measure separate capacitance values for each electrode in array **100** instead of the collective capacitances of subdivided electrode elements connected in rows and columns, a circuit **401** is provided for each electrode in array **100** and multiplexer **402** is

Art Unit: 3992

enlarged to accommodate the outputs from all circuits **401**. *See id.* at col. 4:14-21. The output of synchronous detector and filter **404** is converted to digital form by analog-to-digital converter **405** and forwarded to microcontroller **406** so that microcontroller 406 obtains a digital value representing the capacitance seen by any row or column of electrode elements (or electrode if measured separately) selected by multiplexer **402**. *See id.* at col. 4:22-28. Particularly, Boie discloses driving the electrodes of electrode array 100 and guard planes 411 with a single RF signal for minimizing the effects of electrode-to-electrode capacitances, wiring capacitances and other extraneous capacitances. *See id.* at col. 4:58-61.

Thus, Boie does not teach or suggest the microcontroller is used to selectively providing signal output frequencies to input touch terminals of a keypad.

Accordingly, Boie does not teach or suggest the above-identified underlined claimed features.

Gerpheide

Gerpheide teaches a system and method for a capacitance-based proximity sensor with interference rejection. *See* Abstract. The system **10** comprises an electrode array **12**, a synchronous electrode capacitance measurement unit **14**, a reference frequency generator **16**, and a position locator **18**. *See id.* at Figure 1, and col. 3:52 to col. 4:26. The electrode array consists of multiple X electrodes **20** and Y electrodes **22**. *See id.* at Figures 2A and 2B. The synchronous electrode capacitance measurement unit **14** is connected to the electrode array **12** and the reference frequency generator **16** for producing capacitive measurement signals. *See id.* at Figure 4, and col. 5:50-67. Particularly, Gerpheide teaches that the reference frequency generator **16** includes an oscillator **100** for driving a microcontroller **102** and a divide-by-(M+N) circuit **104**, for providing signal output frequencies and always selecting a reference frequency away from frequencies which have been found to result in measurement interference; wherein, N is a fixed constant, approximately 50, and M is specified by the microcontroller **102** to be, for example, one of four values in the ranges 61 KHz to 80 KHz as specified by the microcontroller **102**; and wherein, the microcontroller **102** performs the functions of interference evaluation 106 and frequency selection 108. *See id.* at Figure 7, and col. 8:20-43.

Thus, Gerpheide does not teach or suggest the synchronous electrode capacitance measurement unit is responsive to signals from the oscillator via said microcontroller and the presence of an operator's body capacitance (CBODY) to ground.

Accordingly, Gerpheide does not teach or suggest the above-identified underlined claimed features.

Casio

Casio teaches a Casio Calculator Watch, which is a timepiece product employing electro-touch technology. The watch works by reading finger-strokes traced across its face. *See id.* at col. 1. The transparent touch panel construction includes a fiberglass panel having a transparent

Art Unit: 3992

conductor film pattern (first layer) and a dielectric layer (second layer) overlying the fiberglass. See *id.* at col. 2. The touch panel determines figure and math symbols outlined with finger-strokes traced across the face. See *id.* at col. 1. The touch panel senses the input, and then digitizes it to extract features of the figure or math symbol. See *id.* at col. 2. The watch then outputs the corresponding figure or math symbol on the screen.

Thus, Casio does not teach or suggest the microcontroller is used to selectively providing signal output frequencies to input touch terminals of a keypad.

Accordingly, Casio does not teach or suggest the above-identified underlined claimed features.

Lee

Lee discloses a fast-scanning multiple-touch-sensitive input device comprising: a sensor matrix board, row and column selection registers, A/D converting circuits and a dedicated CPU. See *id.* at Figure 3.4. The row selection registers select one or more rows by setting the corresponding bits to a high state in order to charge up the sensors while the column selection registers select one or more columns by turn on corresponding analog switches to discharge the sensors through timing resistors. The intersecting region of the selected rows and the selected columns represents the selected sensors as a unit. See *id.* at Figure 3.1(a) shows a model of a selected sensor in the sensor matrix, Figure 3.1 (b) shows the timing diagram for discharging time measurement of a selected sensor, and Figure 3.2 illustrates a small section of a sensor matrix. Particularly, Lee describes the interface between the CPU and the sensor matrix as follows: The CPU selects the row or rows of a sensor group, initiating charging of all the associated sensors. After a charging interval, the CPU discharges the selected column or columns corresponding to a sensor group by connecting a group of discharge resistors whose current is summed via a high slew rate operational amplifier. Wherein, the CPU selects or deselects the row(s) by sending binary signals to the selected row(s). See *id.* at Figs. 3.1(a), 3.1(b), and 3.4, and page 3-10. As illustrated by the data bus of Figure 3.4.

Thus, Lee does not teach or suggest sending signal output frequencies to the selected rows and/or column.

Accordingly, Lee does not teach or suggest the above-identified underlined claimed features.

The above cited prior art references, Boie, Gerpheide, Casio and/or Lee, disclose conventional capacitive responsive switching devices for an operator provide an input by proximity and touch.

However, said cited prior art references, either alone or in any reasonable combinations, fail to teach or suggest the above-identified underlined claimed features.

Any comments considered necessary by PATENT OWNER regarding the above statement must be submitted promptly to avoid processing delays. Such submission by the patent owner should be labeled: "Comments on Statement of Reasons for Patentability and/or Confirmation" and will be placed in the reexamination file.

VII. INFORMATION DISCLOSURE STATEMENT

With respect to the Information Disclosure Statements (PTO/SB/08A and 08B or its equivalent) filed on 12/24/2013, the material has been considered with this action, the information cited thereon has been considered to the extent suggested in the MPEP. Note that MPEP §§ 2256 and 2656 indicate that degree of consideration to be given to such information will be normally limited by the degree to which the party filing the information citation has explained the content and relevance of the information.

Any duplicate citations noticed by the examiner have been lined through.

VIII. CONCLUSION

A. Extensions of Time

Extensions of time under 37 CFR 1.136(a) will not be permitted in these proceedings because the provisions of 37 CFR 1.136 apply only to "an applicant" and not to parties in a reexamination proceeding. Additionally, 35 U.S.C. 305 requires that reexamination proceedings "will be conducted with special dispatch" (37 CFR 1.550(a)). Extension of time in *ex parte* reexamination proceedings are provided for in 37 CFR 1.550(c).

B. Litigation Reminder

The patent owner is reminded of the continuing responsibility under 37 CFR 1.565(a) to apprise the Office of any litigation activity, or other prior or concurrent proceeding, involving the '183 patent throughout the course of this reexamination proceeding. See MPEP §§ 2207, 2282 and 2286.

C. Amendment Proposed in Reexamination – 37 CFR 1.530(d)-(j)

Patent owner is notified that any proposed amendment to the specification and/or claims in this reexamination proceeding must comply with 37 CFR 1.530(d)-(j), must be formally presented pursuant to 37 CFR 1.52(a) and (b), and must contain any fees required by 37 CFR 1.20(c).

D. Correspondence and Inquiry as to Office Actions

All correspondence related to this ex parte reexamination proceeding should be directed as follows:

By EFS: Registered users may submit via the electronic filing system EFS-Web, at <https://efs.uspto.gov/efile/myportal/efs-registered>

By Mail to: Mail Stop *Ex Parte* Reexam
Central Reexamination Unit
Commissioner for Patents
United States Patent & Trademark Office
P.O. Box 1450
Alexandria, VA 22313-1450

By FAX to: (571) 273-9900
Central Reexamination Unit

By hand: Customer Service Window
Randolph Building
401 Dulany Street
Alexandria, VA 2231

For EFS-Web transmissions, 37 CFR 1.8(a)(1)(i) (C) and (ii) states that correspondence (except for a request for reexamination and a corrected or replacement request for reexamination) will be considered timely filed if (a) it is transmitted via the Office's electronic filing system in accordance with 37 CFR 1.6(a)(4), and (b) includes a certificate of transmission for each piece of correspondence stating the data of transmission, which is prior to the expiration of the set period of time in the Office action.

Any inquiry by the patent owner concerning this communication or earlier communications from the Legal Advisor or Examiner, or as to the status of this proceeding, should be directed to the Central Reexamination Unit at telephone number (571) 272-7705.

Signed:

/Henry N Tran/
Patent Reexamination Specialist,
CRU - Art Unit 3992

Conferees:

/Albert Gagliardi/
Patent Reexamination Specialist,
CRU - Art Unit 3992

/SUDHANSHU PATHAK/
Supervisory Patent Examiner, Art Unit 3992

Receipt date: 12/24/2013

90013106 - GAU: 3992

Doc code: IDS

Doc description: Information Disclosure Statement (IDS) Filed

PTO/SB/08a (01-10)

Approved for use through 07/31/2012. OMB 0651-0031

U.S. Patent and Trademark Office; U.S. DEPARTMENT OF COMMERCE

Under the Paperwork Reduction Act of 1995, no persons are required to respond to a collection of information unless it contains a valid OMB control number.

INFORMATION DISCLOSURE STATEMENT BY APPLICANT (Not for submission under 37 CFR 1.99)	Application Number		
	Filing Date		
	First Named Inventor	Byron Hourmand	
	Art Unit	3992	
	Examiner Name	H. Tran	
	Attorney Docket Number	5796183RX	

U.S. PATENTS							Remove	
Examiner Initial*	Cite No	Patent Number	Kind Code ¹	Issue Date	Name of Patentee or Applicant of cited Document	Pages, Columns, Lines where Relevant Passages or Relevant Figures Appear		
	1	4766368		1988-08-23	Cox			
	2	4825385		1989-04-25	Dolph, et al.			
	3	5305017		1994-04-19	Gerpheide			
	4	5337353		1994-08-09	Boie, et al.			
	5	5463388		1995-10-31	Boie, et al.			
	6	5565658		1996-10-15	Gerpheide, et al.			
If you wish to add additional U.S. Patent citation information please click the Add button.							Add	
U.S. PATENT APPLICATION PUBLICATIONS							Remove	
Examiner Initial*	Cite No	Publication Number	Kind Code ¹	Publication Date	Name of Patentee or Applicant of cited Document	Pages, Columns, Lines where Relevant Passages or Relevant Figures Appear		

INFORMATION DISCLOSURE STATEMENT BY APPLICANT (Not for submission under 37 CFR 1.99)	Application Number		90013106 - GAU: 3992	
	Filing Date			
	First Named Inventor	Byron Hourmand		
	Art Unit			
	Examiner Name			
	Attorney Docket Number		5796183RX	

1						
---	--	--	--	--	--	--

If you wish to add additional U.S. Published Application citation information please click the Add button. **Add**

FOREIGN PATENT DOCUMENTS								Remove
Examiner Initial*	Cite No	Foreign Document Number ³	Country Code ²	Kind Code ⁴	Publication Date	Name of Patentee or Applicant of cited Document	Pages, Columns, Lines where Relevant Passages or Relevant Figures Appear	T ⁵
	1							<input type="checkbox"/>

If you wish to add additional Foreign Patent Document citation information please click the Add button. **Add**

NON-PATENT LITERATURE DOCUMENTS			Remove
Examiner Initials*	Cite No	Include name of the author (in CAPITAL LETTERS), title of the article (when appropriate), title of the item (book, magazine, journal, serial, symposium, catalog, etc), date, pages(s), volume-issue number(s), publisher, city and/or country where published.	T ⁵
	1	BUXTON, B., "31.1: Invited Paper: A Touching Story: A Personal Perspective on the History of Touch Interfaces Past and Future," Society for Information Display (SID) Symposium Digest of Technical Papers, Vol. 41, No. 1, Session 31, May 2010, pp. 444-448.	<input type="checkbox"/>
	2	HINCKLEY, K., et al., "38.2: Direct Display Interaction via Simultaneous Pen + Multi-touch Input," Society for Information Display (SID) Symposium Digest of Technical Papers, Vol. 41, No. 1, Session 38, May 2010, pp. 537-540.	<input type="checkbox"/>
	3	LEE, S., "A Fast Multiple-Touch-Sensitive Input Device," University of Toronto, Department of Electrical Engineering, Master Thesis, October 1984, 118 pages.	<input type="checkbox"/>
	4	HILLIS, W.D., "A High-Resolution Imaging Touch Sensor," The International Journal of Robotics Research, Vol. 1, No. 2, Summer (June - Aug.) 1982, pp. 33-44.	<input type="checkbox"/>
	5	LEE, S.K., et al., "A Multi-Touch Three Dimensional Touch-Sensitive Tablet," Proceedings of the SIGCHI Conference on Human Factors in Computing Systems, April 1985, pp. 21-25.	<input type="checkbox"/>

INFORMATION DISCLOSURE STATEMENT BY APPLICANT (Not for submission under 37 CFR 1.99)	Application Number		90013106 - GAU: 3992
	Filing Date		
	First Named Inventor	Byron Hourmand	
	Art Unit		
	Examiner Name		
	Attorney Docket Number		5796183RX

6	HLADY, A.M., "A touch sensitive X-Y position encoder for computer input," Proceedings of the Fall Joint Computer Conference, November 18-20, 1969, pp. 545-551.	<input type="checkbox"/>
7	SASAKI, L., et al., "A Touch-Sensitive Input Device," International Computer Music Conference Proceedings, November 1981, pp. 293-296.	<input type="checkbox"/>
8	CALLAHAN, J., et al., "An Empirical Comparison of Pie vs. Linear Menus," Human Factors in Computing Systems: Chicago '88 Conference Proceedings: May 15-19, 1988, Washington DC: Special Issue of the SIGCHI Bulletin, New York, Association for Computing Machinery, pp. 95-100.	<input type="checkbox"/>
9	CASIO, AT-550 Advertisement, published in Popular Science by On The Run, February 1984, p.-129.	<input type="checkbox"/>
10	CASIO, "Module No. 320," AT-550 Owner's Manual, at least as early as December 1984, 14 pages.	<input type="checkbox"/>
11	SMITH, S.D., et al., "Bit-slice microprocessors in h.f. digital communications," The Radio and Electronic Engineer, Vol. 51, No. 6, June 1981, pp. 299-301.	<input type="checkbox"/>
12	BOIE, R.A., "Capacitive Impedance Readout Tactile Image Sensor," Proceedings of the IEEE International Conference on Robotics and Automation, Vol. 1, March 1984, pp. 370-372.	<input type="checkbox"/>
13	THOMPSON, C., "Clive Thompson on The Breakthrough Myth," Wired Magazine, http://www.wired.com/magazine/2011/07/st_thompson_breakthrough , August 2011, 3 pages.	<input type="checkbox"/>
14	"Innovation in Information Technology," National Research Council of the National Academies, Computer Science and Telecommunications Board, Division on Engineering and Physical Sciences, http://www.nap.edu/catalog/10795.html , 2003, 85 pages.	<input type="checkbox"/>
15	BUXTON, W., et al., "Issues and Techniques in Touch-Sensitive Tablet Input," Proceedings of SIGGRAPH '85, Vol. 19, No. 3, July 22-26, 1985, pp. 215-223.	<input type="checkbox"/>
16	BUXTON, W., et al., "Large Displays in Automotive Design," IEEE Computer Graphics and Applications, July/August 2000, pp. 68-75.	<input type="checkbox"/>

INFORMATION DISCLOSURE STATEMENT BY APPLICANT (Not for submission under 37 CFR 1.99)	Application Number		90013106 - GAU: 3992
	Filing Date		
	First Named Inventor	Byron Hourmand	
	Art Unit		
	Examiner Name		
	Attorney Docket Number	5796183RX	

17	BUXTON, W., "Lexical and Pragmatic Considerations of Input Structures," ACM SIGGRAPH Computer Graphics, Vol. 17, No. 1, January 1983, pp. 31-37.	<input type="checkbox"/>
18	BETTS, P., et al., "Light Beam Matrix Input Terminal," IBM Technical Disclosure Bulletin, October 1966, pp. 493-494.	<input type="checkbox"/>
19	BUXTON, B., "Multi-Touch Systems that I Have Known and Loved," downloaded from http://www.billbuxton.com/multitouchOverview.html , January 12, 2007, 22 pages.	<input type="checkbox"/>
20	HEROT, C.F., et al., "One-Point Touch Input of Vector Information for Computer Displays," Proceedings of the 5th Annual Conference on Computer Graphics and Interactive Techniques, August 23-25, 1978, pp. 210-216.	<input type="checkbox"/>
21	WOLFELD, J.A., "Real Time Control of a Robot Tactile Sensor," University of Pennsylvania, Department of Computer & Information Science, Technical Reports (CIS), Master Thesis, http://repository.upenn.edu/cis-reports/678 , August 1981, 68 pages.	<input type="checkbox"/>
22	LEWIS, J.R., "Reaping the Benefits of Modern Usability Evaluation: The Simon Story," Advances in Applied Ergonomics: Proceedings of the 1st International Conference on Applied Ergonomics, ICAE May 21-24, 1996, pp. 752-755.	<input type="checkbox"/>
23	NAKATANI, L.H., et al., "Soft Machines: A Philosophy of User-Computer Interface Design," Proceedings of the SIGCHI Conference on Human Factors in Computing Systems, December 1983, Chicago, pp. 19-23.	<input type="checkbox"/>
24	RUBINE, D.H., "The Automatic Recognition of Gestures," Carnegie Mellon University, Master Thesis, CMU-CS-91-202, December, 1991, 285 pages.	<input type="checkbox"/>
25	KURTENBACH, G.P., "The Design and Evaluation of Marking Menus," University of Toronto, Graduate Department of Computer Science, Master Thesis, May 1993, 201 pages.	<input type="checkbox"/>
26	HOPKINS, D., "The Design and Implementation of Pie Menus," originally published in Dr. Dobb's Journal, December 1991, lead cover story, user interface issue, reproduced at www.DonHopkins.com , 8 pages.	<input type="checkbox"/>
27	BUXTON, B., "The Long Nose of Innovation," Bloomberg Businessweek, Innovation & Design, January 2, 2008, 3 pages, downloaded from: http://www.businessweek.com/stories/2008-01-02/the-long-nose-of-innovationbusinessweek-business-news-stock-market-and-financialadvice .	<input type="checkbox"/>

INFORMATION DISCLOSURE STATEMENT BY APPLICANT (Not for submission under 37 CFR 1.99)	Application Number		90013106 - GAU: 3992	
	Filing Date			
	First Named Inventor	Byron Hourmand		
	Art Unit			
	Examiner Name			
	Attorney Docket Number		5796183RX	

28	BUXTON, B., "The Mad Dash Toward Touch Technology," Bloomberg Businessweek, Innovation & Design, October 21, 2009, 3 pages, downloaded from: http://www.businessweek.com/innovate/content/oct2009/id20091021_629186.htm .	<input type="checkbox"/>
29	"The Sensor Frame Graphic Manipulator," NASA Phase II Final Report, NASA-CR-194243, May 8, 1992, 28 pages.	<input type="checkbox"/>
30	IZADI, S., et al., "ThinSight: A Thin Form-Factor Interactive Surface Technology," Communications of the ACM, Research Highlights, Vol. 52, No. 12, December 2009, pp. 90-98.	<input type="checkbox"/>
31	KRUEGER, M.W., et al., "VIDEOPLACE - An Artificial Reality," Proceedings of the SIGCHI Conference on Human Factors in Computing Systems, April 1985, pp. 35-40.	<input type="checkbox"/>
32	BROWN, E., et al., "Windows on Tablets as a Means of Achieving Virtual Input Devices," Proceedings of the IFIP TC13 Third International Conference on Human-Computer Interaction, August 27-31, 1990, in D. Diaper, et al. (Eds), Human-Computer Interaction - INTERACT '90, Amsterdam: Elsevier Science Publishers B.V. (North Holland), 11 pages.	<input type="checkbox"/>
33	"A Multi-Touch Three Dimensional Touch-Sensitive Tablet," http://www.youtube.com/watch?v=Arrus9CxUiA , November 18, 2009, 1 page.	<input type="checkbox"/>
34	"Casio AT-550 Touch Screen Calculator Watch (1984)," http://www.youtube.com/watch?v=UhVAsqhfhqU , May 24, 2012, 1 page.	<input type="checkbox"/>

If you wish to add additional non-patent literature document citation information please click the Add button **Add**

EXAMINER SIGNATURE

Examiner Signature	/Henry Tran/ (03/18/2014)	Date Considered	
--------------------	---------------------------	-----------------	--

*EXAMINER: Initial if reference considered, whether or not citation is in conformance with MPEP 609. Draw line through a citation if not in conformance and not considered. Include copy of this form with next communication to applicant.

¹ See Kind Codes of USPTO Patent Documents at www.USPTO.GOV or MPEP 901.04. ² Enter office that issued the document, by the two-letter code (WIPO Standard ST.3). ³ For Japanese patent documents, the indication of the year of the reign of the Emperor must precede the serial number of the patent document. ⁴ Kind of document by the appropriate symbols as indicated on the document under WIPO Standard ST.16 if possible. ⁵ Applicant is to place a check mark here if English language translation is attached.

INFORMATION DISCLOSURE STATEMENT BY APPLICANT (Not for submission under 37 CFR 1.99)	Application Number		90013106 - GAU: 3992
	Filing Date		
	First Named Inventor	Byron Hourmand	
	Art Unit		
	Examiner Name		
	Attorney Docket Number	5796183RX	

CERTIFICATION STATEMENT

Please see 37 CFR 1.97 and 1.98 to make the appropriate selection(s):

That each item of information contained in the information disclosure statement was first cited in any communication from a foreign patent office in a counterpart foreign application not more than three months prior to the filing of the information disclosure statement. See 37 CFR 1.97(e)(1).

OR

That no item of information contained in the information disclosure statement was cited in a communication from a foreign patent office in a counterpart foreign application, and, to the knowledge of the person signing the certification after making reasonable inquiry, no item of information contained in the information disclosure statement was known to any individual designated in 37 CFR 1.56(c) more than three months prior to the filing of the information disclosure statement. See 37 CFR 1.97(e)(2).

- See attached certification statement.
- The fee set forth in 37 CFR 1.17 (p) has been submitted herewith.
- A certification statement is not submitted herewith.

SIGNATURE

A signature of the applicant or representative is required in accordance with CFR 1.33, 10.18. Please see CFR 1.4(d) for the form of the signature.

Signature	/Brian A. Carlson/	Date (YYYY-MM-DD)	2013-12-24
Name/Print	Brian A. Carlson	Registration Number	37,793

This collection of information is required by 37 CFR 1.97 and 1.98. The information is required to obtain or retain a benefit by the public which is to file (and by the USPTO to process) an application. Confidentiality is governed by 35 U.S.C. 122 and 37 CFR 1.14. This collection is estimated to take 1 hour to complete, including gathering, preparing and submitting the completed application form to the USPTO. Time will vary depending upon the individual case. Any comments on the amount of time you require to complete this form and/or suggestions for reducing this burden, should be sent to the Chief Information Officer, U.S. Patent and Trademark Office, U.S. Department of Commerce, P.O. Box 1450, Alexandria, VA 22313-1450. **DO NOT SEND FEES OR COMPLETED FORMS TO THIS ADDRESS. SEND TO: Commissioner for Patents, P.O. Box 1450, Alexandria, VA 22313-1450.**

Privacy Act Statement

The Privacy Act of 1974 (P.L. 93-579) requires that you be given certain information in connection with your submission of the attached form related to a patent application or patent. Accordingly, pursuant to the requirements of the Act, please be advised that: (1) the general authority for the collection of this information is 35 U.S.C. 2(b)(2); (2) furnishing of the information solicited is voluntary; and (3) the principal purpose for which the information is used by the U.S. Patent and Trademark Office is to process and/or examine your submission related to a patent application or patent. If you do not furnish the requested information, the U.S. Patent and Trademark Office may not be able to process and/or examine your submission, which may result in termination of proceedings or abandonment of the application or expiration of the patent.

The information provided by you in this form will be subject to the following routine uses:

1. The information on this form will be treated confidentially to the extent allowed under the Freedom of Information Act (5 U.S.C. 552) and the Privacy Act (5 U.S.C. 552a). Records from this system of records may be disclosed to the Department of Justice to determine whether the Freedom of Information Act requires disclosure of these records.
2. A record from this system of records may be disclosed, as a routine use, in the course of presenting evidence to a court, magistrate, or administrative tribunal, including disclosures to opposing counsel in the course of settlement negotiations.
3. A record in this system of records may be disclosed, as a routine use, to a Member of Congress submitting a request involving an individual, to whom the record pertains, when the individual has requested assistance from the Member with respect to the subject matter of the record.
4. A record in this system of records may be disclosed, as a routine use, to a contractor of the Agency having need for the information in order to perform a contract. Recipients of information shall be required to comply with the requirements of the Privacy Act of 1974, as amended, pursuant to 5 U.S.C. 552a(m).
5. A record related to an International Application filed under the Patent Cooperation Treaty in this system of records may be disclosed, as a routine use, to the International Bureau of the World Intellectual Property Organization, pursuant to the Patent Cooperation Treaty.
6. A record in this system of records may be disclosed, as a routine use, to another federal agency for purposes of National Security review (35 U.S.C. 181) and for review pursuant to the Atomic Energy Act (42 U.S.C. 218(c)).
7. A record from this system of records may be disclosed, as a routine use, to the Administrator, General Services, or his/her designee, during an inspection of records conducted by GSA as part of that agency's responsibility to recommend improvements in records management practices and programs, under authority of 44 U.S.C. 2904 and 2906. Such disclosure shall be made in accordance with the GSA regulations governing inspection of records for this purpose, and any other relevant (i.e., GSA or Commerce) directive. Such disclosure shall not be used to make determinations about individuals.
8. A record from this system of records may be disclosed, as a routine use, to the public after either publication of the application pursuant to 35 U.S.C. 122(b) or issuance of a patent pursuant to 35 U.S.C. 151. Further, a record may be disclosed, subject to the limitations of 37 CFR 1.14, as a routine use, to the public if the record was filed in an application which became abandoned or in which the proceedings were terminated and which application is referenced by either a published application, an application open to public inspections or an issued patent.
9. A record from this system of records may be disclosed, as a routine use, to a Federal, State, or local law enforcement agency, if the USPTO becomes aware of a violation or potential violation of law or regulation.

ALL REFERENCES CONSIDERED EXCEPT WHERE LINED THROUGH. /HT/

<i>Index of Claims</i> 	Application/Control No. 90013106	Applicant(s)/Patent Under Reexamination 5796183
	Examiner HENRY N TRAN	Art Unit 3992

✓	Rejected	-	Cancelled	N	Non-Elected	A	Appeal
=	Allowed	÷	Restricted	I	Interference	O	Objected

Claims renumbered in the same order as presented by applicant
 CPA
 T.D.
 R.1.47

CLAIM		DATE									
Final	Original	03/20/2014									
	1	N									
	2	N									
	3	N									
	4	N									
	5	N									
	6	N									
	7	N									
	8	N									
	9	N									
	10	N									
	11	N									
	12	N									
	13	N									
	14	N									
	15	N									
	16	N									
	17	N									
	18	✓									
	19	N									
	20	N									
	21	N									
	22	N									
	23	N									
	24	N									
	25	N									
	26	N									
	27	✓									
	28	N									
	29	N									
	30	N									
	31	N									
	32	N									
	33	N									
	34	N									
	35	-									
	36	N									

Index of Claims 	Application/Control No. 90013106	Applicant(s)/Patent Under Reexamination 5796183
	Examiner HENRY N TRAN	Art Unit 3992

✓	Rejected	-	Cancelled	N	Non-Elected	A	Appeal
=	Allowed	÷	Restricted	I	Interference	O	Objected

Claims renumbered in the same order as presented by applicant
 CPA
 T.D.
 R.1.47

CLAIM		DATE									
Final	Original	03/20/2014									
	37	N									
	38	N									
	39	N									
	40	✓									
	41	✓									
	42	✓									
	43	✓									
	44	✓									
	45	=									
	46	=									
	47	=									
	48	=									
	49	=									
	50	=									
	51	=									
	52	=									
	53	=									
	54	=									
	55	=									
	56	✓									
	57	✓									
	58	✓									
	59	✓									
	60	✓									
	61	✓									
	62	✓									
	63	✓									
	64	✓									
	65	✓									
	66	✓									
	67	✓									
	68	✓									
	69	✓									
	70	✓									
	71	✓									
	72	=									

<i>Index of Claims</i> 	Application/Control No. 90013106	Applicant(s)/Patent Under Reexamination 5796183
	Examiner HENRY N TRAN	Art Unit 3992

✓	Rejected	-	Cancelled	N	Non-Elected	A	Appeal
=	Allowed	÷	Restricted	I	Interference	O	Objected

Claims renumbered in the same order as presented by applicant
 CPA
 T.D.
 R.1.47

CLAIM		DATE									
Final	Original	03/20/2014									
	73	=									
	74	=									
	75	=									
	76	=									
	77	=									
	78	=									
	79	=									
	80	=									
	81	=									
	82	=									
	83	=									
	84	=									
	85	=									
	86	=									
	87	=									
	88	=									
	89	=									
	90	=									
	91	=									
	92	=									
	93	=									
	94	=									
	95	✓									
	96	✓									
	97	✓									
	98	✓									
	99	✓									
	100	✓									
	101	✓									
	102	✓									
	103	✓									
	104	✓									
	105	✓									

Reexamination 	Application/Control No. 90013106	Applicant(s)/Patent Under Reexamination 5796183
	Certificate Date 04/29/2013	Certificate Number 5796183C1

Requester Correspondence Address:	<input checked="" type="checkbox"/> Patent Owner	<input type="checkbox"/> Third Party
SLATER & MATSIL, L.L.P. 17950 PRESTON RD, SUITE 1000 DALLAS, TX 75252-5793		

LITIGATION REVIEW <input checked="" type="checkbox"/>	/HT/ (examiner initials)	03/10/2014 (date)
Case Name		Director Initials
1:06cv 1777 - CLOSED		
2:03cv75169 - CLOSED		
1:10cv691 - CLOSED		
2:06cv500 -CLOSED		

COPENDING OFFICE PROCEEDINGS	
TYPE OF PROCEEDING	NUMBER
1. NONE	

	/HENRY N TRAN/ Primary Examiner.Art Unit 3992
--	--

Search Notes 	Application/Control No. 90013106	Applicant(s)/Patent Under Reexamination 5796183
	Examiner HENRY N TRAN	Art Unit 3992

CPC- SEARCHED		
Symbol	Date	Examiner

CPC COMBINATION SETS - SEARCHED		
Symbol	Date	Examiner

US CLASSIFICATION SEARCHED			
Class	Subclass	Date	Examiner

SEARCH NOTES		
Search Notes	Date	Examiner
Review of patented file's prosecution history	03/102014/	HT

INTERFERENCE SEARCH			
US Class/ CPC Symbol	US Subclass / CPC Group	Date	Examiner

	/HENRY N TRAN/ Primary Examiner.Art Unit 3992
--	--

IN THE UNITED STATES PATENT AND TRADEMARK OFFICE

U.S. Patent No.: 5,796,183 B1 § Docket No.: 5796183RX2
Issued: August 18, 1998 § Inventors: Hourmand et al.
Filed: January 31, 1996 § Patent Owner: UUSI, LLC
Control No. 90/013,106 § Examiner: Henry N. Tran
For: Capacitive Responsive Electronic Switching Circuit

Mail Stop *Ex Parte* Reexam
Attn: Central Reexamination Unit
Commissioner for Patents
P.O. Box 1450
Alexandria, VA 22313-1450

WAIVER OF PATENT OWNER'S STATEMENT

Dear Sir:

Patent Owner UUSI, LLC respectfully notifies the Office that Patent Owner waives the filing of a statement under 37 C.F.R. § 1.530 to expedite the reexamination proceeding. Patent Owner respectfully requests that the reexamination proceeding be allowed to proceed immediately pursuant to 37 C.F.R. § 1.550(a). *See* M.P.E.P. § 2249.

If the Examiner should have any questions, please contact the Patent Owner's Attorney, Brian A. Carlson, at 972-732-1001. The Commissioner is hereby authorized to charge any fees due in connection with this filing, or credit any overpayment, to Deposit Account No. 50-1065.

Respectfully submitted,

March 4, 2014
Date

/Brian A. Carlson/
Brian A. Carlson
Reg. No. 37,793

Slater & Matsil, L.L.P.
17950 Preston Rd., Suite 1000
Dallas, TX 75252
972-732-1001
972-732-9218 (fax)

Electronic Acknowledgement Receipt

EFS ID:	18368569
Application Number:	90013106
International Application Number:	
Confirmation Number:	9188
Title of Invention:	Capacitive Responsive Electronic Switching Circuit
First Named Inventor/Applicant Name:	5796183
Customer Number:	25962
Filer:	Brian A. Carlson/Michelle Hatcher
Filer Authorized By:	Brian A. Carlson
Attorney Docket Number:	NAR-5796183RX2
Receipt Date:	04-MAR-2014
Filing Date:	24-DEC-2013
Time Stamp:	18:08:23
Application Type:	Reexam (Patent Owner)

Payment information:

Submitted with Payment	no
------------------------	----

File Listing:

Document Number	Document Description	File Name	File Size(Bytes)/ Message Digest	Multi Part /.zip	Pages (if appl.)
1	Miscellaneous Incoming Letter	NAR-5796183RX2_WaiverOfPatentOwnerStatement.pdf	17322 <small>b992900dd5ad2cd0648f69ed45e716cc7863ac26</small>	no	1

Warnings:

Information:

This Acknowledgement Receipt evidences receipt on the noted date by the USPTO of the indicated documents, characterized by the applicant, and including page counts, where applicable. It serves as evidence of receipt similar to a Post Card, as described in MPEP 503.

New Applications Under 35 U.S.C. 111

If a new application is being filed and the application includes the necessary components for a filing date (see 37 CFR 1.53(b)-(d) and MPEP 506), a Filing Receipt (37 CFR 1.54) will be issued in due course and the date shown on this Acknowledgement Receipt will establish the filing date of the application.

National Stage of an International Application under 35 U.S.C. 371

If a timely submission to enter the national stage of an international application is compliant with the conditions of 35 U.S.C. 371 and other applicable requirements a Form PCT/DO/EO/903 indicating acceptance of the application as a national stage submission under 35 U.S.C. 371 will be issued in addition to the Filing Receipt, in due course.

New International Application Filed with the USPTO as a Receiving Office

If a new international application is being filed and the international application includes the necessary components for an international filing date (see PCT Article 11 and MPEP 1810), a Notification of the International Application Number and of the International Filing Date (Form PCT/RO/105) will be issued in due course, subject to prescriptions concerning national security, and the date shown on this Acknowledgement Receipt will establish the international filing date of the application.



UNITED STATES PATENT AND TRADEMARK OFFICE

UNITED STATES DEPARTMENT OF COMMERCE
United States Patent and Trademark Office
Address: COMMISSIONER FOR PATENTS
P.O. Box 1450
Alexandria, Virginia 22313-1450
www.uspto.gov

APPLICATION NO.	FILING DATE	FIRST NAMED INVENTOR	ATTORNEY DOCKET NO.	CONFIRMATION NO.
-----------------	-------------	----------------------	---------------------	------------------

90/013,106	12/24/2013	5796183	NAR-5796183RX2	9188
------------	------------	---------	----------------	------

25962 7590 02/26/2014
 SLATER & MATSIL, L.L.P.
 17950 PRESTON RD, SUITE 1000
 DALLAS, TX 75252-5793

EXAMINER

TRAN, HENRY N

ART UNIT	PAPER NUMBER
----------	--------------

3992

MAIL DATE	DELIVERY MODE
-----------	---------------

02/26/2014

PAPER

Please find below and/or attached an Office communication concerning this application or proceeding.

The time period for reply, if any, is set in the attached communication.

Order Granting / Denying Request For Ex Parte Reexamination	Control No. 90/013,106	Patent Under Reexamination 5796183
	Examiner HENRY N. TRAN	Art Unit 3992

--The MAILING DATE of this communication appears on the cover sheet with the correspondence address--

The request for *ex parte* reexamination filed 24 December 2013 has been considered and a determination has been made. An identification of the claims, the references relied upon, and the rationale supporting the determination are attached.

Attachments: a) PTO-892, b) PTO/SB/08, c) Other: _____

1. The request for *ex parte* reexamination is GRANTED.

RESPONSE TIMES ARE SET AS FOLLOWS:

For Patent Owner's Statement (Optional): TWO MONTHS from the mailing date of this communication (37 CFR 1.530 (b)). **EXTENSIONS OF TIME ARE GOVERNED BY 37 CFR 1.550(c).**

For Requester's Reply (optional): TWO MONTHS from the **date of service** of any timely filed Patent Owner's Statement (37 CFR 1.535). **NO EXTENSION OF THIS TIME PERIOD IS PERMITTED.** If Patent Owner does not file a timely statement under 37 CFR 1.530(b), then no reply by requester is permitted.

2. The request for *ex parte* reexamination is DENIED.

This decision is not appealable (35 U.S.C. 303(c)). Requester may seek review by petition to the Commissioner under 37 CFR 1.181 within ONE MONTH from the mailing date of this communication (37 CFR 1.515(c)). **EXTENSION OF TIME TO FILE SUCH A PETITION UNDER 37 CFR 1.181 ARE AVAILABLE ONLY BY PETITION TO SUSPEND OR WAIVE THE REGULATIONS UNDER 37 CFR 1.183.**

In due course, a refund under 37 CFR 1.26 (c) will be made to requester:

- a) by Treasury check or,
- b) by credit to Deposit Account No. _____, or
- c) by credit to a credit card account, unless otherwise notified (35 U.S.C. 303(c)).

/HENRY N TRAN/ Primary Examiner, Art Unit 3992		
---	--	--

cc:Requester (if third party requester)

The present application is being examined under the pre-AIA first to invent provisions.

DECISION GRANTING EX PARTE REEXAMINATION

I. DECISION

1. A substantial new question of patentability (SNQ) affecting claims 18 and 27 of United States Patent Number 5,796,183 C1 to Hourmand et al. (the '183 patent) is raised by the request for *ex parte* reexamination under 35 U.S.C §§ 301-307 filed by the Patent Owner on December 24, 2013.

2. Pursuant to 37 CFR 1.515, it is agreed that a SNQ affecting claims 18 and 27 of the '183 patent has been found based on the request and the prior art patents and/or publications cited therein.

3. The request for *ex parte* reexamination is granted.

II. PRIOR ART PATENTS AND PUBLICATION CITED IN THE REQUEST

4. In the request for reexamination, the requester alleged that the following prior art patents and publication raise a SNQ as to claims 18 and 27 of the '183 patent:

- U.S. Patent No. 5,463,388 issued to Boie et al. on October 31, 1995 ("Boie" or the '388 patent), and filed with the request as Exhibit C.
- U.S. Patent No. 5,565,658 issued to Gerpheide et al. on October 15, 1996 ("Gerpheide" or the '658 patent), and filed with the request as Exhibit D.
- Casio advertisement entitled "Now... The Invisible Casio Calculator Watch," published in Popular Science by On the Run in 1984 ("Casio"), and filed with the request as Exhibit E.

The cited prior art patents and/or publication submitted with the request pursuant to C.F.R. § 1.510(b) (3) are listed in form PTO/SB/08 filed with the request.

Boie filed on January 29, 1993, Gerpheide filed on December 7, 1994, and Casio published in 1984; and which are all prior to the Critical Date of January 31, 1996 - which is the filing date of the '183 patent - constitute effective prior art reference as to the claims of the '183 patent under 35 U.S.C. §102(a), 102(e), or 102(b).

It is noted that Boie was previously cited/considered, i.e., "old art", by the Office in an earlier concluded *ex parte* reexamination control number 90/012,439 of the patent being reexamined, which is hereinafter referred to as "the first request".

III. A SUBSTANTIAL NEW QUESTION OF PATENTABILITY (SNQ)

5. The requester alleges that the combination of Boie with Gerpheide and/or Casio raises a SNQ regarding claims 18 and 27 of the '183 patent (see the request, section III.C page 17).

IV. PROSECUTION HISTORY OF THE '183 PATENT

6. The '183 patent stems from United States Patent Application No. 08/601,268 (hereinafter referred to as "the base application") and the first request for *ex parte* reexamination.

The examiner generally agrees with the description of the prosecution history found in section I. B of the request at pp. 5-9.

With respect to the Examiner's statement of reasons for patentability of claims 18, 27, 28, and 32-39, the prosecution history of the first request indicates:

- On April 10, 2013, the Notice of Intent to Issue Ex Parte Reexamination Certificate was issued with the Examiner's statement of reasons for patentability of the claims provided in pp. 3-4, which is repeated below:

“There is not taught or disclosed in the prior art *a capacitive responsive electronic switching circuit having a microcontroller using the periodic output signal from the oscillator, the microcontroller selectively providing signal output frequencies to a plurality of small sized input touch terminals of a keypad*, as called for in independent claim 18; nor *a capacitive responsive electronic switching circuit having a microcontroller using the periodic output signal from the oscillator, the microcontroller selectively providing signal output frequencies to a closely spaced array of input touch terminals of a keypad, the input touch terminals comprising first and second input touch terminals*, as called for in independent claims 27 and 37. The examiner agrees with the discussion articulated by Patent Owner in the Statement that Boie does not teach or suggest these claim elements. Rather, Boie discloses that "RF oscillator 408 provides an RF signal, for example, 100 kilohertz, to circuits 401, synchronous detector and filter 404 via inverter 410, and guard plane 411." Boie, col. 3:67-col. 4:2. Boie further discloses that "[t]he effects of electrode-to-electrode capacitances, wiring capacitances and other extraneous capacitances are minimized by driving all electrodes and guard plane 411 in unison with the same RF signal from RF oscillator 408." *Id.* at col. 4:58-60 (emphasis added); *see id.* at Fig. 4. Thus Boie discloses driving the electrodes of electrode array 100 and guard plane 411 with a single RF signal. Boie does not teach or suggest providing signal output frequencies to these components. Accordingly, claims 18, 27, amended non-requested claims 28, 32, and newly added claims 33-39 are patentable.”

- On April 29, 2013, the Ex Parte Reexamination Certificate was issued as United States Patent Number 5,796,183 C1.

7. In view of the prosecution history, it appears that the reason for allowance of claims 18 and 27 is the fact that no cited prior art reference was considered during the prosecution of the '183 patent that teaches or suggests the following limitation or limitations: “*a capacitive responsive electronic switching circuit having a microcontroller using the periodic output signal from the oscillator, the microcontroller selectively providing signal output frequencies to a plurality of small sized input touch terminals of a keypad*” (independent claim 18); and “*a capacitive responsive electronic switching circuit having a microcontroller using the periodic output signal from the oscillator, the microcontroller selectively providing signal output frequencies to a closely spaced array of input touch terminals of a keypad, the input touch terminals comprising first and second input touch terminals*” (independent claim 27).

V. CRITERIA FOR DECIDING REQUEST

8. MPEP § 2240 provides:

37 C.F.R. 1.515 Determination of the request for ex parte reexamination.

- (a) Within three months following the filing date of a request for an *ex parte* reexamination, an examiner will consider the request and determine whether or not a substantial new question of patentability affecting any claim of the patent is raised by the request and the prior art cited therein, with or without consideration of other patents or printed publications. The examiner's determination will be based on the claims in effect at the time of the determination, will become a part of the official file of the patent, and will be mailed to the patent owner at the address as provided for in § **1.33(c)** and to the person requesting reexamination.

9. MPEP § 2242 provides:

For “a substantial new question of patentability” to be present, it is only necessary that: (A) the prior art patents and/or printed publications raise a substantial question of patentability regarding at least one claim, i.e., the teaching of the (prior art) patents and printed publications is such that a reasonable examiner would consider the teaching to be important in deciding whether or not the claim is patentable; and (B) the same question of patentability as to the claim has not been decided by the Office in a previous examination or pending reexamination of the patent or in a final holding of invalidity by the Federal Courts in a decision on the merits involving the claim. It is not necessary that a “*prima facie*” case of unpatentability exist as to the claim in order for “a substantial new question of patentability” to be present as to the claim. Thus, “a substantial new question of patentability” as to a patent claim could be present even if the examiner would not necessarily reject the claim as either fully anticipated by, or obvious in view of, the prior art patents or printed publications. As to the importance of the difference between “a substantial new question of patentability” and a “*prima facie*” case of unpatentability see generally *In re Etter*, 756 F.2d 852, 857 n.5, 225 USPQ 1, 4 n.5 (Fed. Cir. 1985).

VI. ANALYSIS OF PRIOR ART AND PROPOSED REJECTIONS

10. In view of the prosecution history and the criteria for deciding request noted above, it is considered that a prior art reference or a combination of prior art references that discloses or fairly suggests at least some or all of the main components of the claimed invention noted in the reasons for patentability of claims in the first request reexamination of the ‘183 patent, or an equivalent thereof, would raise a SNQ.

11. Summary of the ‘183 patent

The ‘183 patent relates to a capacitive responsive electronic switching circuit including an oscillator providing a periodic output signal, an input touch terminal defining an area for an operator to provide an input by proximity and touch, and a detector circuit coupled to the oscillator for receiving the periodic output signal from the oscillator, and coupled to the input touch terminal. See Abstract.

An embodiment with a single touch terminal is shown in Figure 4, and an embodiment with multiple touch terminals is shown in Figure 11, both of which are reproduced below:

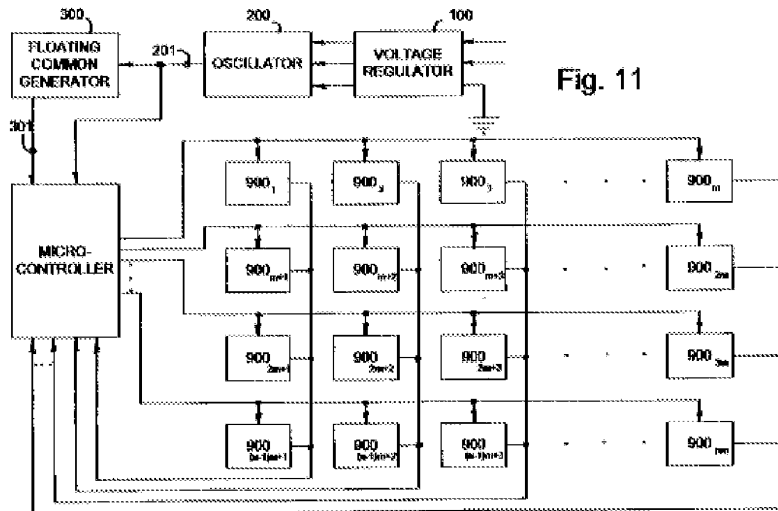
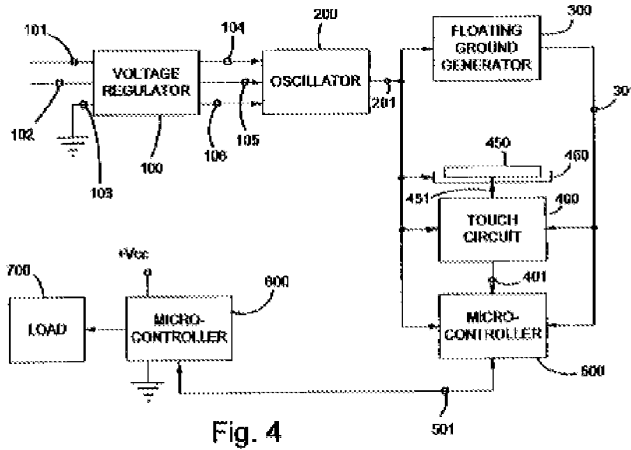

The multiple touch pad circuit of Figure 11 is a variation of the embodiment shown in Figure 4, but with an array of touch circuits designated as 900_1 through 900_{nm} . Microcontroller 500 selects each row of the touch circuits 900_1 to 900_{nm} by providing the signal from oscillator 200 to selected rows of touch circuits. *See, id.* at col.18:43-46. The values of the resistors and capacitors utilized in oscillator 200 may be varied to provide for different oscillator output frequencies. *See, id.* at col. 14:22-25. Although the preferred frequency is at or above 100 kHz, and more preferably at or above 800 kHz, it is conceivable that frequencies as low as 50 kHz could be used provided the frequency creates a difference in the impedance paths of adjacent pads that is sufficient enough to accurately distinguish between an intended touch and the touch of an adjacent pad. *See, id.* at col. 11:19-25. Microcontroller 500 sequentially activates the touch circuit rows and associates the received inputs from the columns

Art Unit: 3992

of the array with the activated touch circuit(s). *See, id.* at col. 18:46-49. The detector circuit is responsive to signals from the oscillator and the presence of an operator's body capacitance to ground coupled to the touch terminal when in proximity or touched by an operator to provide a control output signal. *See, id.* at Abstract. Another method for implementing capacitive touch switches relies on the change in capacitive coupling between a touch terminal and ground. *See, id.* at col. 3:44-46."

12. Summary of the prior art references

Boie

Boie teaches a computer input device for use as a computer mouse or keyboard comprises a thin, insulating surface covering an array of electrodes arranged in a grid pattern and connected in columns and rows, each column and row is connected to circuitry for measuring the capacitance seen by each column and row, and the position of an object with respect to the array is determined from the centroid of such capacitance values, which is calculated in a microcontroller. *See* Abstract. Particularly, Boie Figure 4 illustrates a block diagram of a two-dimensional capacitive position sensor device.

FIG. 4

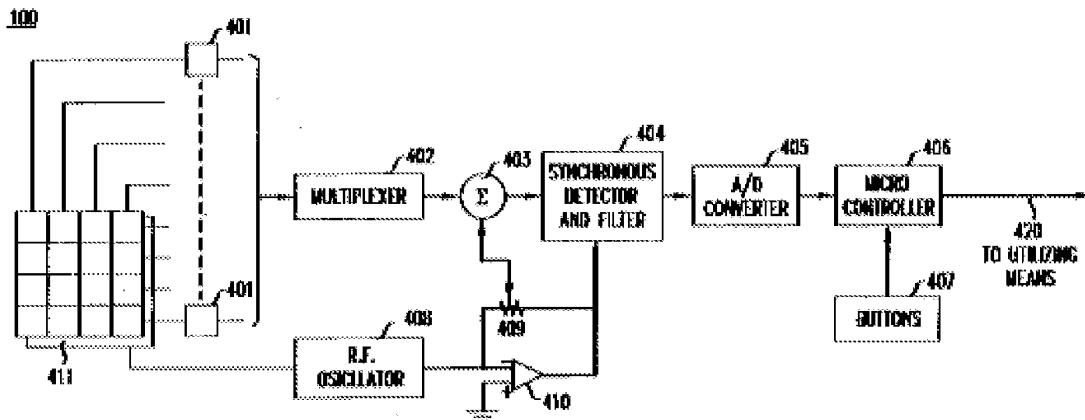

The device comprises an electrode array **100** having rows and columns of electrodes, each row and column of electrodes is connected to an integrating amplifier and bootstrap circuit **401**, each of the outputs from circuits **401** can be selected by multiplexer **402** under control of microcontroller **406**. The selected output is then forwarded to summing circuit **403**, where such output is combined with a signal from trimmer resistor **409**. Synchronous detector and filter **404** convert the output from summing circuit to a signal related to the capacitance of the row or column selected by the multiplexer. RF oscillator **408** provides an RF signal, for example, 100 kilohertz, to circuits **401**, synchronous detector and filter **404** via inverter **410**, and guard plane **411**. Guard plane **411** is a substantially continuous plane parallel to array **100** and associated

connections, and serves to isolate array **100** from extraneous signals. See *id.* at col. 3:67 to col. 4:5. To measure separate capacitance values for each electrode in array **100** instead of the collective capacitances of subdivided electrode elements connected in rows and columns, a circuit **401** is provided for each electrode in array **100** and multiplexer **402** is enlarged to accommodate the outputs from all circuits **401**. See *id.* at col. 4:14-21. The output of synchronous detector and filter **404** is converted to digital form by analog-to-digital converter **405** and forwarded to microcontroller **406**. Thus, microcontroller 406 can obtain a digital value representing the capacitance seen by any row or column of electrode elements (or electrode if measured separately) selected by multiplexer **402**. See *id.* at col. 4:22-28.

Gerpheide

Gerpheide teaches a system and method for a capacitance-based proximity sensor with interference rejection. See Abstract. The system **10** comprises an electrode array **12**, a synchronous electrode capacitance measurement unit **14**, a reference frequency generator **16**, and a position locator **18**. See Figure 1, and col. 3:52 to col. 4:26. The electrode array consists of multiple X electrodes **20** and Y electrodes **22**. See Figures 2A and 2B. The synchronous electrode capacitance measurement unit 14 is connected to the electrode array 12 and the reference frequency generator 16 for producing capacitive measurement signals. See Figure 4, and col. 5:50-67.

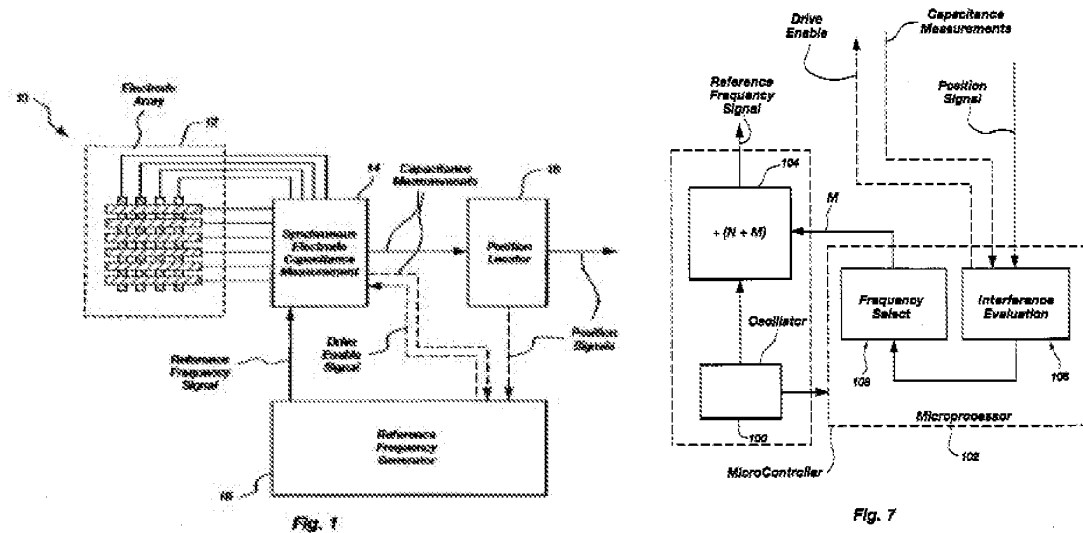

The reference frequency generator includes an oscillator 100 for driving a microcontroller 102 and a divide-by-(M+N) circuit 104, for providing signal output frequencies in the range 61KHz to 80KHz; wherein, N is a fixed constant, and M is specified by the microcontroller using capacitive measurement signals and position signals. See Figure 7, and col. 8:20-38.

Art Unit: 3992

Casio

Casio discloses a Casio Calculator Watch, which is a timepiece product employing electro-touch technology. The watch works by reading finger-strokes traced across its face. See, Casio, col. 1. The transparent touch panel construction includes a fiberglass panel having a transparent conductor film pattern (first layer) and a dielectric layer (second layer) overlying the fiberglass. See *id.* at col. 2. The touch panel determines figure and math symbols outlined with finger-strokes traced across the face. See *id.* at col. 1. The touch panel senses the input, and then digitizes it to extract features of the figure or math symbol. See *id.* at col. 2. The watch then outputs the corresponding figure or math symbol on the screen.

13. Discussion of the Issues

Issue 1: The requester alleges that the combination of Boie with Gerpheide raises a SNQ regarding claim 18 of the '183 patent.

It is agreed that the combination of Boie with Gerpheide raises a SNQ regarding claim 18 of the '183 patent.

As pointed out in the request sections II.B pp. 10-15 and III.A of the claim chart pp. 21-27 for claim 18, Boie teaches a capacitive sensor array 100 comprises a RF oscillator 408 for providing an RF signal having a predefined frequency, e.g., 100KHz, to circuits 401, synchronous detector and filter 404 via inverter 410, and guard plane 411, see Figure 4, and col. 3:67 to col. 4:2.

Gerpheide teaches a capacitive sensor system 10 comprises a reference frequency generator 16 that seeks to always select a reference frequency away from frequencies which have been found to result in measurement interference; wherein, the reference frequency generator includes an oscillator 100 for driving a microcontroller 102 and a divide-by-(M+N) circuit 104 for providing signal output frequencies in the range 61KHz to 80KHz. See Figure 7, and col. 8:20-38.

Thus, Boie and Gerpheide teach the elements and limitations that led to the patentability of claim 18 of the '183 patent.

The teachings of Boie and Gerpheide present a new, non-cumulative technological teachings that was not previously considered in the prosecution of the '183 patent. Furthermore, there is a substantial likelihood that a reasonable examiner would consider the teachings of Boie and Gerpheide important in deciding whether or not claim 18 is patentable.

Accordingly, it is agreed that the combination of Boie and Gerpheide raises a SNQ of claim 18 which has not been decided in the prior examinations of the '183 patent.

Issue 2: The requester allege that the combination of Boie with Gerpheide and/or Casio raises a SNQ regarding claim 27 of the '183 patent.

It is agreed that the combination of Boie with Gerpheide and/or Casio raises a SNQ regarding claim 27 of the '183 patent.

As pointed out in the request sections II.B pp. 10-17 and III.A of the claim chart pp. 27-33 for claim 27, Boie teaches a capacitive sensor array 100 comprises a RF oscillator 408 for providing an RF signal having a predefined frequency, e.g., 100KHz, to circuits 401, synchronous detector and filter 404 via inverter 410, and guard plane 411, see Figure 4, and col. 3:67 to col. 4:2.

Gerpheide teaches a capacitive sensor system 10 comprises a reference frequency generator 16 that seeks to always select a reference frequency away from frequencies which have been found to result in measurement interference; wherein, the reference frequency generator includes an oscillator 100 for driving a microcontroller 102 and a divide-by-(M+N) circuit 104 for providing signal output frequencies in the range 61KHz to 80KHz. See Figure 7, and col. 8:20-38.

Casio teaches a calculator watch employing electro-touch technology using a transparent touch panel (a keypad). The transparent touch panel construction includes a fiberglass panel having a

transparent conductor film pattern (first layer) and a dielectric layer (second layer) overlying the fiberglass. See Figure at col. 2.

Thus, Boie and Gerpheide and/or Casio teach the elements and limitations that led to the patentability of claim 27 of the '183 patent.

The teachings of Boie and Gerpheide and/or Casio present a new, non-cumulative technological teachings that was not previously considered in the prosecution of the '183 patent. Furthermore, there is a substantial likelihood that a reasonable examiner would consider the teachings of Boie and Gerpheide and/or Casio important in deciding whether or not claim 27 is patentable.

Accordingly, it is agreed that the combination of Boie and Gerpheide and/or Casio raises a SNQ of claim 27 which has not been decided in the prior examinations of the '183 patent.

VII. INFORMATION DISCLOSURE STATEMENT

14. With respect to the Information Disclosure Statement (PTO/SB/08A and 08B or its equivalent) filed on 12/24/2013, the material has been considered with this action; the information cited thereon has been considered to the extent suggested in the MPEP.

Note that MPEP §§ 2256 and 2656 indicate that degree of consideration to be given to such information will be normally limited by the degree to which the party filing the information citation has explained the content and relevance of the information. Any duplicate citations noticed by the examiner have been lined through.

It is noted that, according to 37 C.F.R. 1.515 (a), the examiner's decision on the SNQ issues recited in this order is based on only the consideration of patents and publication cited in the request section II.A (page 10). The other patents or printed publications listed in form PTO/SB/08a filed with the request have not been considered and been lined through; and they will be considered after this order as appropriate.

VIII. CONCLUSION

15. The prior art patents and publication, Boie and Gerpheide and Casio, set forth in the request have been considered. They raise SNQs affecting claims 18 and 27 of the '183 patent.

Accordingly, the request for *ex parte* reexamination is granted. Claims 18 and 27 of the '183 patent will be reexamined. Claims 1-17, 19-26, and 28-39 of the '183 patent will not be reexamined.

16. The patent owner is reminded of the continuing responsibility under 37 CFR 1.565(a), to apprise the Office of any litigation activity, or other prior or concurrent proceeding, involving the '183 patent throughout the course of this reexamination proceeding. See MPEP §§ 2207, 2282 and 2286.

17. Extensions of time under 37 CFR 1.136(a) will not be permitted in these proceedings because the provisions of 37 CFR 1.136 apply only to "an applicant" and not to parties in a reexamination proceeding. Additionally, 35 U.S.C. 305 requires that *ex parte* reexamination proceedings "will be conducted with special dispatch" (37 CFR 1.550(a)). Extensions of time in *ex parte* reexamination proceedings are provided for in 37 CFR 1.550(c).

18. Patent owner is notified that any proposed amendment to the specification and/or claims in this reexamination proceeding must comply with 37 CFR 1.530(d)-(j), must be formally presented pursuant to 37 CFR 1.52(a) and (b), and must contain any fees required by 37 CFR 1.20(c).

It is noted that the Patent Owner's Amendment Accompanying Request filed on 12/24/2013 will be addressed subsequently following this Order Granting Request for *ex parte* reexamination as appropriate.

19. **All** correspondence related to this *ex parte* reexamination proceeding should be directed as follows:

By EFS: Registered users may submit via the electronic filing system EFS-Web, at <https://efs.uspto.gov/efile/myportal/efs-registered>

By Mail to: Mail Stop *Ex Parte* Reexam
Central Reexamination Unit
Commissioner for Patents
United States Patent & Trademark Office
P.O. Box 1450
Alexandria, VA 22313-1450

By FAX to: (571) 273-9900
Central Reexamination Unit

By hand: Customer Service Window
Randolph Building
401 Dulany Street
Alexandria, VA 22314

Art Unit: 3992

For EFS-Web transmissions, 37 CFR 1.8(a)(1)(i) (C) and (ii) states that correspondence (except for a request for reexamination and a corrected or replacement request for reexamination) will be considered timely filed if (a) it is transmitted via the Office's electronic filing system in accordance with 37 CFR 1.6(a)(4), and (b) includes a certificate of transmission for each piece of correspondence stating the data of transmission, which is prior to the expiration of the set period of time in the Office action.

Any inquiry by the patent owner concerning this communication or earlier communications from the Legal Advisor or Examiner, or as to the status of this proceeding, should be directed to the Central Reexamination Unit at telephone number (571) 272-7705.

/Henry N Tran/
Patent Reexamination Specialist,
CRU - Art Unit 3992

Conferees:

/Albert Gagliardi/
Patent Reexamination Specialist,
CRU - Art Unit 3992

/Sudhanshu C. Pathak/
Supervisory Patent Reexamination Specialist,
CRU - Art Unit 3992

Order Granting / Denying Request For Ex Parte Reexamination	Control No. 90/013,106	Patent Under Reexamination 5796183
	Examiner HENRY N. TRAN	Art Unit 3992

--The MAILING DATE of this communication appears on the cover sheet with the correspondence address--

The request for *ex parte* reexamination filed 24 December 2013 has been considered and a determination has been made. An identification of the claims, the references relied upon, and the rationale supporting the determination are attached.

Attachments: a) PTO-892, b) PTO/SB/08, c) Other: _____

1. The request for *ex parte* reexamination is GRANTED.

RESPONSE TIMES ARE SET AS FOLLOWS:

For Patent Owner's Statement (Optional): TWO MONTHS from the mailing date of this communication (37 CFR 1.530 (b)). **EXTENSIONS OF TIME ARE GOVERNED BY 37 CFR 1.550(c).**

For Requester's Reply (optional): TWO MONTHS from the **date of service** of any timely filed Patent Owner's Statement (37 CFR 1.535). **NO EXTENSION OF THIS TIME PERIOD IS PERMITTED.** If Patent Owner does not file a timely statement under 37 CFR 1.530(b), then no reply by requester is permitted.

2. The request for *ex parte* reexamination is DENIED.

This decision is not appealable (35 U.S.C. 303(c)). Requester may seek review by petition to the Commissioner under 37 CFR 1.181 within ONE MONTH from the mailing date of this communication (37 CFR 1.515(c)). **EXTENSION OF TIME TO FILE SUCH A PETITION UNDER 37 CFR 1.181 ARE AVAILABLE ONLY BY PETITION TO SUSPEND OR WAIVE THE REGULATIONS UNDER 37 CFR 1.183.**

In due course, a refund under 37 CFR 1.26 (c) will be made to requester:

- a) by Treasury check or,
b) by credit to Deposit Account No. _____, or
c) by credit to a credit card account, unless otherwise notified (35 U.S.C. 303(c)).

/HENRY N TRAN/ Primary Examiner, Art Unit 3992		
---	--	--

cc:Requester (if third party requester)

Search Notes 	Application/Control No. 90013106	Applicant(s)/Patent Under Reexamination 5796183
	Examiner HENRY N TRAN	Art Unit 3992

CPC- SEARCHED		
Symbol	Date	Examiner

CPC COMBINATION SETS - SEARCHED		
Symbol	Date	Examiner

US CLASSIFICATION SEARCHED			
Class	Subclass	Date	Examiner

SEARCH NOTES		
Search Notes	Date	Examiner
Review of patented file's prosecution history	02/06/2014	HT

INTERFERENCE SEARCH			
US Class/ CPC Symbol	US Subclass / CPC Group	Date	Examiner

	/HENRY N TRAN/ Primary Examiner.Art Unit 3992
--	--

Reexamination 	Application/Control No. 90013106	Applicant(s)/Patent Under Reexamination 5796183
	Certificate Date 04/29/2013	Certificate Number 5796183C1

Requester Correspondence Address:	<input checked="" type="checkbox"/> Patent Owner	<input type="checkbox"/> Third Party
SLATER & MATSIL, L.L.P. 17950 PRESTON RD, SUITE 1000 DALLAS, TX 75252-5793		

LITIGATION REVIEW <input checked="" type="checkbox"/>	/HT/ (examiner initials)	02/06/2014 (date)
Case Name		Director Initials
1:06cv 1777 - CLOSED		
2:03cv75169 - CLOSED		
1:10cv691 - CLOSED		
2:06cv500 -CLOSED		

COPENDING OFFICE PROCEEDINGS	
TYPE OF PROCEEDING	NUMBER
1. NONE	

	/HENRY N TRAN/ Primary Examiner.Art Unit 3992
--	--

Receipt date: 12/24/2013

90013106 - GAU: 3992

Doc code: IDS

Doc description: Information Disclosure Statement (IDS) Filed

PTO/SB/08a (01-10)

Approved for use through 07/31/2012. OMB 0651-0031
U.S. Patent and Trademark Office; U.S. DEPARTMENT OF COMMERCE

Under the Paperwork Reduction Act of 1995, no persons are required to respond to a collection of information unless it contains a valid OMB control number.

INFORMATION DISCLOSURE STATEMENT BY APPLICANT (Not for submission under 37 CFR 1.99)	Application Number		90/013106	
	Filing Date		12/24/2013	
	First Named Inventor	Byron Hourmand		
	Art Unit	3992		
	Examiner Name	H. Tran		
	Attorney Docket Number	5796183RX		

U.S. PATENTS							Remove
Examiner Initial*	Cite No	Patent Number	Kind Code ¹	Issue Date	Name of Patentee or Applicant of cited Document	Pages, Columns, Lines where Relevant Passages or Relevant Figures Appear	
	1	4766368		1988-08-23	Cox		
	2	4825385		1989-04-25	Dolph, et al.		
	3	5305017		1994-04-19	Gerpheide		
	4	5337353		1994-08-09	Boie, et al.		
/HT/	5	5463388		1995-10-31	Boie, et al.		
/HT/	6	5565658		1996-10-15	Gerpheide, et al.		
If you wish to add additional U.S. Patent citation information please click the Add button.							Add
U.S. PATENT APPLICATION PUBLICATIONS							Remove
Examiner Initial*	Cite No	Publication Number	Kind Code ¹	Publication Date	Name of Patentee or Applicant of cited Document	Pages, Columns, Lines where Relevant Passages or Relevant Figures Appear	

INFORMATION DISCLOSURE STATEMENT BY APPLICANT (Not for submission under 37 CFR 1.99)	Application Number		90013106 - GAU: 3992	
	Filing Date			
	First Named Inventor	Byron Hourmand		
	Art Unit			
	Examiner Name			
	Attorney Docket Number		5796183RX	

1							
---	--	--	--	--	--	--	--

If you wish to add additional U.S. Published Application citation information please click the Add button. **Add**

FOREIGN PATENT DOCUMENTS								Remove
Examiner Initial*	Cite No	Foreign Document Number ³	Country Code ²	Kind Code ⁴	Publication Date	Name of Patentee or Applicant of cited Document	Pages, Columns, Lines where Relevant Passages or Relevant Figures Appear	T ⁵
	1							<input type="checkbox"/>

If you wish to add additional Foreign Patent Document citation information please click the Add button. **Add**

NON-PATENT LITERATURE DOCUMENTS								Remove
Examiner Initials*	Cite No	Include name of the author (in CAPITAL LETTERS), title of the article (when appropriate), title of the item (book, magazine, journal, serial, symposium, catalog, etc), date, pages(s), volume-issue number(s), publisher, city and/or country where published.					T ⁵	
	1	BUXTON, B., "31.1: Invited Paper: A Touching Story: A Personal Perspective on the History of Touch Interfaces Past and Future," Society for Information Display (SID) Symposium Digest of Technical Papers, Vol. 41, No. 1, Session 31, May 2010, pp. 444-448.					<input type="checkbox"/>	
	2	HINCKLEY, K., et al., "38.2: Direct Display Interaction via Simultaneous Pen + Multi-touch Input," Society for Information Display (SID) Symposium Digest of Technical Papers, Vol. 41, No. 1, Session 38, May 2010, pp. 537-540.					<input type="checkbox"/>	
	3	LEE, S., "A Fast Multiple-Touch-Sensitive Input Device," University of Toronto, Department of Electrical Engineering, Master Thesis, October 1984, 118 pages.					<input type="checkbox"/>	
	4	HILLIS, W.D., "A High-Resolution Imaging Touch Sensor," The International Journal of Robotics Research, Vol. 1, No. 2, Summer (June - Aug.) 1982, pp. 33-44.					<input type="checkbox"/>	
	5	LEE, S.K., et al., "A Multi-Touch Three Dimensional Touch-Sensitive Tablet," Proceedings of the SIGCHI Conference on Human Factors in Computing Systems, April 1985, pp. 21-25.					<input type="checkbox"/>	

INFORMATION DISCLOSURE STATEMENT BY APPLICANT (Not for submission under 37 CFR 1.99)	Application Number		90013106 - GAU: 3992
	Filing Date		
	First Named Inventor	Byron Hourmand	
	Art Unit		
	Examiner Name		
	Attorney Docket Number		5796183RX

	6	HLADY, A.M., "A touch sensitive X-Y position encoder for computer input," Proceedings of the Fall Joint Computer Conference, November 18-20, 1969, pp. 545-551.	<input type="checkbox"/>
	7	SASAKI, L., et al., "A Touch-Sensitive Input Device," International Computer Music Conference Proceedings, November 1981, pp. 293-296.	<input type="checkbox"/>
	8	CALLAHAN, J., et al., "An Empirical Comparison of Pie vs. Linear Menus," Human Factors in Computing Systems: Chicago '88 Conference Proceedings: May 15-19, 1988, Washington DC: Special Issue of the SIGCHI Bulletin, New York: Association for Computing Machinery, pp. 95-100.	<input type="checkbox"/>
/HT/	9	CASIO, AT-550 Advertisement, published in Popular Science by On The Run, February 1984, p.-129.	<input type="checkbox"/>
	10	CASIO, "Module No. 320," AT-550 Owner's Manual, at least as early as December 1984, 14 pages.	<input type="checkbox"/>
	11	SMITH, S.D., et al., "Bit-slice microprocessors in h.f. digital communications," The Radio and Electronic Engineer, Vol. 51, No. 6, June 1981, pp. 299-301.	<input type="checkbox"/>
	12	BOIE, R.A., "Capacitive Impedance Readout Tactile Image Sensor," Proceedings of the IEEE International Conference on Robotics and Automation, Vol. 1, March 1984, pp. 370-372.	<input type="checkbox"/>
	13	THOMPSON, C., "Clive Thompson on The Breakthrough Myth," Wired Magazine, http://www.wired.com/magazine/2011/07/st_thompson_breakthrough , August 2011, 3 pages.	<input type="checkbox"/>
	14	"Innovation in Information Technology," National Research Council of the National Academies, Computer Science and Telecommunications Board, Division on Engineering and Physical Sciences, http://www.nap.edu/catalog/10795.html , 2003, 85 pages.	<input type="checkbox"/>
	15	BUXTON, W., et al., "Issues and Techniques in Touch-Sensitive Tablet Input," Proceedings of SIGGRAPH '85, Vol. 19, No. 3, July 22-26, 1985, pp. 215-223.	<input type="checkbox"/>
	16	BUXTON, W., et al., "Large Displays in Automotive Design," IEEE Computer Graphics and Applications, July/August 2000, pp. 68-75.	<input type="checkbox"/>

INFORMATION DISCLOSURE STATEMENT BY APPLICANT (Not for submission under 37 CFR 1.99)	Application Number		90013106 - GAU: 3992
	Filing Date		
	First Named Inventor	Byron Hourmand	
	Art Unit		
	Examiner Name		
	Attorney Docket Number	5796183RX	

17	BUXTON, W., "Lexical and Pragmatic Considerations of Input Structures," ACM SIGGRAPH Computer Graphics, Vol. 17, No. 1, January 1983, pp. 31-37.	<input type="checkbox"/>
18	BETTS, P., et al., "Light Beam Matrix Input Terminal," IBM Technical Disclosure Bulletin, October 1966, pp. 493-494.	<input type="checkbox"/>
19	BUXTON, B., "Multi-Touch Systems that I Have Known and Loved," downloaded from http://www.billbuxton.com/multitouchOverview.html , January 12, 2007, 22 pages.	<input type="checkbox"/>
20	HEROT, C.F., et al., "One-Point Touch Input of Vector Information for Computer Displays," Proceedings of the 5th Annual Conference on Computer Graphics and Interactive Techniques, August 23-25, 1978, pp. 210-216.	<input type="checkbox"/>
21	WOLFELD, J.A., "Real Time Control of a Robot Tactile Sensor," University of Pennsylvania, Department of Computer & Information Science, Technical Reports (CIS), Master Thesis, http://repository.upenn.edu/cis-reports/678 , August 1981, 68 pages.	<input type="checkbox"/>
22	LEWIS, J.R., "Reaping the Benefits of Modern Usability Evaluation: The Simon Story," Advances in Applied Ergonomics: Proceedings of the 1st International Conference on Applied Ergonomics, ICAE May 21-24, 1996, pp. 752-755.	<input type="checkbox"/>
23	NAKATANI, L.H., et al., "Soft Machines: A Philosophy of User-Computer Interface Design," Proceedings of the SIGCHI Conference on Human Factors in Computing Systems, December 1983, Chicago, pp. 19-23.	<input type="checkbox"/>
24	RUBINE, D.H., "The Automatic Recognition of Gestures," Carnegie Mellon University, Master Thesis, CMU-CS-91-202, December, 1991, 285 pages.	<input type="checkbox"/>
25	KURTENBACH, S.P., "The Design and Evaluation of Marking Menus," University of Toronto, Graduate Department of Computer Science, Master Thesis, May 1993, 201 pages.	<input type="checkbox"/>
26	HOPKINS, D., "The Design and Implementation of Pie Menus," originally published in Dr. Dobb's Journal, December 1991, lead cover story, user interface issue, reproduced at www.DonHopkins.com , 8 pages.	<input type="checkbox"/>
27	BUXTON, B., "The Long Nose of Innovation," Bloomberg Businessweek, Innovation & Design, January 2, 2008, 3 pages, downloaded from: http://www.businessweek.com/stories/2008-01-02/the-long-nose-of-innovationbusinessweek-business-news-stock-market-and-financialadvice .	<input type="checkbox"/>

INFORMATION DISCLOSURE STATEMENT BY APPLICANT (Not for submission under 37 CFR 1.99)	Application Number		90013106 - GAU: 3992
	Filing Date		
	First Named Inventor	Byron Hourmand	
	Art Unit		
	Examiner Name		
	Attorney Docket Number		5796183RX

28	BUXTON, B., "The Mad Dash Toward Touch Technology," Bloomberg Businessweek, Innovation & Design, October 21, 2009, 3 pages, downloaded from: http://www.businessweek.com/innovate/content/oct2009/id20091021_629786.htm .	<input type="checkbox"/>
29	"The Sensor Frame Graphic Manipulator," NASA Phase II Final Report, NASA-CR-194243, May 8, 1992, 28 pages.	<input type="checkbox"/>
30	IZADI, S., et al., "ThinSight: A Thin Form-Factor Interactive Surface Technology," Communications of the ACM, Research Highlights, Vol. 52, No. 12, December 2009, pp. 90-98.	<input type="checkbox"/>
31	KRUEGER, M.W., et al., "VIDEOPACE - An Artificial Reality," Proceedings of the SIGCHI Conference on Human Factors in Computing Systems, April 1985, pp. 35-40.	<input type="checkbox"/>
32	BROWN, E., et al., "Windows on Tablets as a Means of Achieving Virtual Input Devices," Proceedings of the IFIP TC13 Third International Conference on Human-Computer Interaction, August 27-31, 1990, in D. Diaper, et al. (Eds), Human-Computer Interaction - INTERACT '90, Amsterdam: Elsevier Science Publishers B.V. (North Holland), 11 pages.	<input type="checkbox"/>
33	"A Multi-Touch Three Dimensional Touch-Sensitive Tablet," http://www.youtube.com/watch?v=Arrus9CxUiA , November 18, 2009, 1 page.	<input type="checkbox"/>
34	"Casio AT-550 Touch Screen Calculator Watch (1984)," http://www.youtube.com/watch?v=UhVAsqhfqU , May 24, 2012, 1 page.	<input type="checkbox"/>

If you wish to add additional non-patent literature document citation information please click the Add button **Add**

EXAMINER SIGNATURE

Examiner Signature	/Henry Tran/ (02/20/2014)	Date Considered	
--------------------	---------------------------	-----------------	--

*EXAMINER: Initial if reference considered, whether or not citation is in conformance with MPEP 609. Draw line through a citation if not in conformance and not considered. Include copy of this form with next communication to applicant.

¹ See Kind Codes of USPTO Patent Documents at www.USPTO.GOV or MPEP 901.04. ² Enter office that issued the document, by the two-letter code (WIPO Standard ST.3). ³ For Japanese patent documents, the indication of the year of the reign of the Emperor must precede the serial number of the patent document. ⁴ Kind of document by the appropriate symbols as indicated on the document under WIPO Standard ST.16 if possible. ⁵ Applicant is to place a check mark here if English language translation is attached.

INFORMATION DISCLOSURE STATEMENT BY APPLICANT (Not for submission under 37 CFR 1.99)	Application Number		90013106 - GAU: 3992
	Filing Date		
	First Named Inventor	Byron Hourmand	
	Art Unit		
	Examiner Name		
	Attorney Docket Number	5796183RX	

CERTIFICATION STATEMENT

Please see 37 CFR 1.97 and 1.98 to make the appropriate selection(s):

That each item of information contained in the information disclosure statement was first cited in any communication from a foreign patent office in a counterpart foreign application not more than three months prior to the filing of the information disclosure statement. See 37 CFR 1.97(e)(1).

OR

That no item of information contained in the information disclosure statement was cited in a communication from a foreign patent office in a counterpart foreign application, and, to the knowledge of the person signing the certification after making reasonable inquiry, no item of information contained in the information disclosure statement was known to any individual designated in 37 CFR 1.56(c) more than three months prior to the filing of the information disclosure statement. See 37 CFR 1.97(e)(2).

- See attached certification statement.
- The fee set forth in 37 CFR 1.17 (p) has been submitted herewith.
- A certification statement is not submitted herewith.

SIGNATURE

A signature of the applicant or representative is required in accordance with CFR 1.33, 10.18. Please see CFR 1.4(d) for the form of the signature.

Signature	/Brian A. Carlson/	Date (YYYY-MM-DD)	2013-12-24
Name/Print	Brian A. Carlson	Registration Number	37,793

This collection of information is required by 37 CFR 1.97 and 1.98. The information is required to obtain or retain a benefit by the public which is to file (and by the USPTO to process) an application. Confidentiality is governed by 35 U.S.C. 122 and 37 CFR 1.14. This collection is estimated to take 1 hour to complete, including gathering, preparing and submitting the completed application form to the USPTO. Time will vary depending upon the individual case. Any comments on the amount of time you require to complete this form and/or suggestions for reducing this burden, should be sent to the Chief Information Officer, U.S. Patent and Trademark Office, U.S. Department of Commerce, P.O. Box 1450, Alexandria, VA 22313-1450. **DO NOT SEND FEES OR COMPLETED FORMS TO THIS ADDRESS. SEND TO: Commissioner for Patents, P.O. Box 1450, Alexandria, VA 22313-1450.**

Privacy Act Statement

The Privacy Act of 1974 (P.L. 93-579) requires that you be given certain information in connection with your submission of the attached form related to a patent application or patent. Accordingly, pursuant to the requirements of the Act, please be advised that: (1) the general authority for the collection of this information is 35 U.S.C. 2(b)(2); (2) furnishing of the information solicited is voluntary; and (3) the principal purpose for which the information is used by the U.S. Patent and Trademark Office is to process and/or examine your submission related to a patent application or patent. If you do not furnish the requested information, the U.S. Patent and Trademark Office may not be able to process and/or examine your submission, which may result in termination of proceedings or abandonment of the application or expiration of the patent.

The information provided by you in this form will be subject to the following routine uses:

1. The information on this form will be treated confidentially to the extent allowed under the Freedom of Information Act (5 U.S.C. 552) and the Privacy Act (5 U.S.C. 552a). Records from this system of records may be disclosed to the Department of Justice to determine whether the Freedom of Information Act requires disclosure of these records.
2. A record from this system of records may be disclosed, as a routine use, in the course of presenting evidence to a court, magistrate, or administrative tribunal, including disclosures to opposing counsel in the course of settlement negotiations.
3. A record in this system of records may be disclosed, as a routine use, to a Member of Congress submitting a request involving an individual, to whom the record pertains, when the individual has requested assistance from the Member with respect to the subject matter of the record.
4. A record in this system of records may be disclosed, as a routine use, to a contractor of the Agency having need for the information in order to perform a contract. Recipients of information shall be required to comply with the requirements of the Privacy Act of 1974, as amended, pursuant to 5 U.S.C. 552a(m).
5. A record related to an International Application filed under the Patent Cooperation Treaty in this system of records may be disclosed, as a routine use, to the International Bureau of the World Intellectual Property Organization, pursuant to the Patent Cooperation Treaty.
6. A record in this system of records may be disclosed, as a routine use, to another federal agency for purposes of National Security review (35 U.S.C. 181) and for review pursuant to the Atomic Energy Act (42 U.S.C. 218(c)).
7. A record from this system of records may be disclosed, as a routine use, to the Administrator, General Services, or his/her designee, during an inspection of records conducted by GSA as part of that agency's responsibility to recommend improvements in records management practices and programs, under authority of 44 U.S.C. 2904 and 2906. Such disclosure shall be made in accordance with the GSA regulations governing inspection of records for this purpose, and any other relevant (i.e., GSA or Commerce) directive. Such disclosure shall not be used to make determinations about individuals.
8. A record from this system of records may be disclosed, as a routine use, to the public after either publication of the application pursuant to 35 U.S.C. 122(b) or issuance of a patent pursuant to 35 U.S.C. 151. Further, a record may be disclosed, subject to the limitations of 37 CFR 1.14, as a routine use, to the public if the record was filed in an application which became abandoned or in which the proceedings were terminated and which application is referenced by either a published application, an application open to public inspections or an issued patent.
9. A record from this system of records may be disclosed, as a routine use, to a Federal, State, or local law enforcement agency, if the USPTO becomes aware of a violation or potential violation of law or regulation.

Litigation Search Report CRU 3999

Reexam Control No. 90/013,106

TO: Henry Tran Location: CRU Art Unit: 3992 Date: 01/27/2014	From: Shanette Brown Location: CRU 3999 MDE 05D10 Phone: (571) 272-6632 Shanett.Brown@uspto.gov
---	--

Search Notes

RE: 90/013,106–Litigation was found for US Patent Number: 5,796,183

Patent	Class	Subclass	Description	Court	Docket Number	Filed	Date Retrieved
5,796,183	307	116	QRG, Ltd, A/K/A Quantum Research Group, Ltd v. Nartron Corporatio	US-DIS-PAMD	1:06cv1777 CLOSED	9/12/2006	5/7/2008
5,796,183	307	116	Nartron Corporation et al v. Hourmand	US-DIS-MIWD	1:10cv691 CLOSED	7/20/2010	10/29/2010
5,796,183	307	116	Nartron Corp v. Gen Elec, et al	US-DIS-MIED	2:03cv75169 CLOSED	12/24/2003	1/5/2012
5,796,183	307	116	QRG, Ltd v. Nartron Corporation	US-DIS-PAWD	2:06cv500 CLOSED	4/13/2006	5/7/2008

Sources:

- 1) I performed a KeyCite Search in Westlaw, which retrieves all history on the patent including any litigation.
- 2) I performed a search on the patent in Lexis CourtLink for any open dockets or closed cases.
- 3) I performed a search in Lexis in the Federal Courts and Administrative Materials databases for any cases found.
- 4) I performed a search in Lexis in the IP Journal and Periodicals database for any articles on the patent.
- 5) I performed a search in Lexis in the news databases for any articles about the patent or any articles about litigation on this patent.

Westlaw Delivery Summary Report for BROWN,SHANETTE L

Date/Time of Request:	Sunday, January 26, 2014 14:47 Central
Client Identifier:	SB
Database:	KEYCITE-HIST
Citation Text:	US PAT 5796183
Service:	KeyCite
Lines:	369
Documents:	1
Images:	0

The material accompanying this summary is subject to copyright. Usage is governed by contract with Thomson Reuters, West and their affiliates.



Date of Printing: Jan 26, 2014

KEYCITE

© US PAT 5796183 CAPACITIVE RESPONSIVE ELECTRONIC SWITCHING CIRCUIT, Assignee: Nartron Corporation (Aug 18, 1998)

History

Direct History

=> 1 **CAPACITIVE RESPONSIVE ELECTRONIC SWITCHING CIRCUIT**, US PAT 5796183, 1998 WL 1463338 (U.S. PTO Utility Aug 18, 1998)

Patent Family

2 CAPACITIVE REACTION ELECTRONIC SWITCH FOR ZERO FORCE APPLICATION CONTAINS OSCILLATOR SUPPLYING FREQUENCY OF 50 KHZ OR HIGHER, AND INPUT TOUCH TERMINAL, Derwent World Patents Legal 1997-394976+

Assignments

- 3 Action: ASSIGNMENT OF ASSIGNORS INTEREST (SEE DOCUMENT FOR DETAILS).
Number of Pages: 002, (DATE RECORDED: Aug 17, 2012)
- 4 Action: ASSIGNMENT OF ASSIGNORS INTEREST (SEE DOCUMENT FOR DETAILS).
Number of Pages: 002, (DATE RECORDED: Aug 17, 2012)
- 5 Action: ASSIGNMENT OF ASSIGNORS INTEREST (SEE DOCUMENT FOR DETAILS).
Number of Pages: 011, (DATE RECORDED: Dec 22, 2009)
- 6 ASSIGNEE(S): NARTRON CORPORATION, (DATE RECORDED: Feb 04, 1997)
- 7 Assignee(s): NARTRON CORPORATION, (DATE RECORDED: Jan 31, 1996)

Patent Status Files

- .. Re-Examination Certificate, (OG DATE: May 07, 2013)
- .. Request for Re-Examination, (OG DATE: Oct 02, 2012)
- .. Certificate of Correction, (OG DATE: Nov 01, 2011)
- .. Certificate of Correction, (OG DATE: May 11, 1999)

Docket Summaries

- 12 NARTRON CORPORATION ET AL v. HOURMAND, (W.D.MICH. Jul 20, 2010) (NO. 1:10CV00691), (28 USC 1338 PATENT INFRINGEMENT)
- 13 "QRG, LTD. v. NARTRON CORPORATION", (M.D.PA. Sep 12, 2006) (NO. 1:06CV01777), (28 USC 2201 DECLARATORY JUDGEMENT)

© 2014 Thomson Reuters. All rights reserved.

14 "NARTRON CORP v. GEN ELEC, ET AL", (E.D.MICH. Dec 24, 2003) (NO. 2:03CV75169)

Litigation Alert

15 Derwent LitAlert P2010-30-63 (Jul 20, 2010) Action Taken: complaint for PATENT INFRINGEMENT

16 Derwent LitAlert P2007-35-68 (Sep 12, 2006) Action Taken: A complaint was filed

17 Derwent LitAlert P2007-02-10 (Apr 13, 2006) Action Taken: Order of court - Ordered that motion to dismiss by defendant is denied. Further ordered that the case is to be transferred to the US District Court for the Middle Dist of Pennsylvania

Prior Art (Coverage Begins 1976)

- 18 CAPACITIVE PRESS CONTROL ACTUATION SYSTEM, US PAT 5235217 Assignee: ISB Ltd., (U.S. PTO Utility 1993)
- 19 CAPACITIVE SENSOR CONTROL SYSTEM, US PAT 4323829 Assignee: Fish, Barry M., (U.S. PTO Utility 1982)
- 20 CAPACITY RESPONSIVE CONTROL CIRCUIT, US PAT 4831279 Assignee: Nartron Corporation, (U.S. PTO Utility 1989)
- 21 CAPACITY RESPONSIVE KEYBOARD, US PAT 5087825 Assignee: Nartron Corporation, (U.S. PTO Utility 1992)
- 22 CHARGE SENSITIVE SWITCH, US PAT 4159473 Assignee: Johnson-Lazare Canada Limited, (U.S. PTO Utility 1979)
- 23 CONTROL-SAFE CAPACITIVE SWITCH, US PAT 5233231 Assignee: Pepperl + Fuchs, Inc., (U.S. PTO Utility 1993)
- 24 DC TOUCH CONTROL SWITCH CIRCUIT, US PAT 4758735 Assignee: Nartron Corporation, (U.S. PTO Utility 1988)
- 25 DISCRIMINATING CONTACT SENSOR, US PAT 3911215 Assignee: ELOGRAPHICS, INC., (U.S. PTO Utility 1975)
- 26 DISPLAY DEVICE HAVING UNPATTERNED TOUCH DETECTION, US PAT 4476463 Assignee: Interaction Systems, Inc., (U.S. PTO Utility 1984)
- 27 ELECTROGRAPHIC SENSOR FOR DETERMINING PLANAR COORDINATES, US PAT 3798370 Assignee: ELOGRAPHICS, INC., (U.S. PTO Utility 1974)
- 28 ELECTRONIC SWITCH ARRANGEMENTS, US PAT 3651391 Assignee: BLACK & DECKER INC., (U.S. PTO Utility 1972)
- 29 ELECTRONIC WATCH WITH TOUCH-SENSITIVE KEYS, US PAT 4257117 Assignee: Ebauches S.A., (U.S. PTO Utility 1981)
- 30 ELECTRONICALLY ACTUATED ELECTRIC SWITCH, US PAT 4213061 (U.S. PTO Utility 1980)
- 31 HAND SANITIZING STATION, US PAT 4942631 Assignee: Barry Robertson; Rosa, Rudy, (U.S. PTO Utility 1990)
- 32 INDUCTION COOK-TOP WITH IMPROVED TOUCH CONTROL, US PAT 4308443 Assignee:

- Rangaire Corporation, (U.S. PTO Utility 1981)
- © 33 KEYBOARD SWITCH, US PAT 4503294 Assignee: Nippon Mektron Ltd., (U.S. PTO Utility 1985)
 - © 34 LAMP RESPONSIVE TO THE HUMAN TOUCH UPON A LIVING PLANT AND CONTROL SYSTEM THEREFOR, US PAT 4152629 (U.S. PTO Utility 1979)
 - © 35 LUCENT ELECTROGRAPHIC SENSOR FOR DETERMINING PLANAR COORDINATES, US PAT 4071689 Assignee: Elographics, Incorporated, (U.S. PTO Utility 1978)
 - © 36 MULTI-WAY SWITCH SYSTEM HAVING PLURAL REMOTE TOUCH PADS, US PAT 5066898 Assignee: Delat Systems, Incorporated, (U.S. PTO Utility 1991)
 - © 37 NONPLANAR TRANSPARENT ELECTROGRAPHIC SENSOR, US PAT 4220815 Assignee: Elographics, Inc., (U.S. PTO Utility 1980)
 - © 38 PERSONAL-CARE APPARATUS COMPRISING A CAPACITIVE ON/OFF SWITCH, US PAT 5453644 Assignee: U.S. Philips Corporation, (U.S. PTO Utility 1995)
 - © 39 PROXIMITY ACTUATED POWER CONTROL VARIABLE AS TO SENSE AND MAGNITUDE, US PAT 3984757 (U.S. PTO Utility 1976)
 - © 40 PROXIMITY CONTROLLED POWER SWITCHING CIRCUIT, US PAT 4246533 (U.S. PTO Utility 1981)
 - © 41 PROXIMITY PAD WITH CONTROLLED ILLUMINATION, US PAT 4016453 (U.S. PTO Utility 1977)
 - © 42 PROXIMITY SWITCHING SYSTEM, US PAT 4031408 (U.S. PTO Utility 1977)
 - © 43 SELF TIMING SWITCH, US PAT 3965465 (U.S. PTO Utility 1976)
 - © 44 SINGLE-ELECTRODE CAPACITANCE TOUCHPAD SENSOR SYSTEMS, US PAT 4237421 Assignee: General Electric Company, (U.S. PTO Utility 1980)
 - © 45 TOUCH ACTIVATED AC, FULL WAVE, TWO WIRE SWITCHES, US PAT 3549909 Assignee: HALL?BARKAN INSTRUMENTS, INC., (U.S. PTO Utility 1970)
 - H 46 TOUCH-CONTROL ADAPTER FOR ELECTRIC LAMPS, US PAT 4211959 Assignee: Westek Corporation, (U.S. PTO Utility 1980)
 - © 47 TOUCH CONTROL FOR ELECTRICAL APPARATUS, US PAT 3641410 Assignee: BLACK \$#amp;#amp; DECKER INC., (U.S. PTO Utility 1972)
 - © 48 TOUCH CONTROL SWITCH, US PAT 4289972 (U.S. PTO Utility 1981)
 - © 49 TOUCH CONTROL SWITCH, US PAT 4264831 (U.S. PTO Utility 1981)
 - © 50 TOUCH CONTROL SWITCH, US PAT 4210822 (U.S. PTO Utility 1980)
 - © 51 TOUCH CONTROL SWITCH CIRCUIT, US PAT 4731548 Assignee: Nartron Corporation, (U.S. PTO Utility 1988)
 - © 52 TOUCH CONTROL SYSTEM, US PAT 5572205 Assignee: Donnelly Technology, Inc., (U.S. PTO Utility 1996)
 - © 53 TOUCH CONTROLLED DISPLAY DEVICE, US PAT 4910504 Assignee: Touch Display Systems AB, (U.S. PTO Utility 1990)
 - © 54 TOUCH CONTROLLED ELECTRIC LIGHT SOCKET WITH HIGH CURRENT TOLERANCE, US PAT 5208516 (U.S. PTO Utility 1993)

- 55 TOUCH LAMP, LATCHING AC SOLID STATE TOUCH SWITCH USABLE WITH SUCH LAMP, AND CIRCUITS FOR THE SAME, US PAT 3899713 Assignee: HALL BARKAN INSTRUMENTS, INC., (U.S. PTO Utility 1975)
- 56 TOUCH OVERLAY FOR IMPROVED TOUCH SENSITIVITY, US PAT 5386219 Assignee: International Business Machines Corp., (U.S. PTO Utility 1995)
- 57 TOUCH RESPONSIVE POWER CONTROL SYSTEM, US PAT 4939382 (U.S. PTO Utility 1990)
- 58 TOUCH-RESPONSIVE SOCKET, US PAT 4101805 Assignee: Destron, Inc., (U.S. PTO Utility 1978)
- 59 TOUCH SENSITIVE CONTROL PANEL, US PAT 5012124 (U.S. PTO Utility 1991)
- 60 TOUCH SENSITIVE ELECTRIC SWITCH, US PAT 4289980 (U.S. PTO Utility 1981)
- 61 TOUCH SENSITIVE ELECTRONIC SWITCH, US PAT 3879618 Assignee: MAGIC DOT, INC., (U.S. PTO Utility 1975)
- 62 TOUCH SENSITIVE POWER CONTROL CIRCUIT, US PAT 3666988 Assignee: ROBERT E BELLIS, (U.S. PTO Utility 1972)
- 63 TOUCH SENSITIVE POWER CONTROL SYSTEM, US PAT 3919596 Assignee: BELLIS ROBERT ELLIOTT, (U.S. PTO Utility 1975)
- 64 TOUCH SENSITIVE SWITCH, US PAT 4360737 Assignee: Leviton Manufacturing Co., Inc., (U.S. PTO Utility 1982)
- 65 TOUCH SWITCH CIRCUITS, US PAT 4119864 Assignee: RCA Corporation, (U.S. PTO Utility 1978)
- 66 TOUCH SWITCH DEVICE, US PAT 4352141 Assignee: Starcote Limited, (U.S. PTO Utility 1982)
- 67 TOUCH TERMINAL WITH RELIABLE PAD SELECTION, US PAT 4374381 Assignee: Interaction Systems, Inc., (U.S. PTO Utility 1983)

US District Court Civil Docket

U.S. District - Michigan Western
(Southern Division 1)

1:10cv691

Nartron Corporation et al v. Hourmand

This case was retrieved from the court on Sunday, January 26, 2014

Date Filed: 07/20/2010	Class Code: CLOSED
Assigned To: Judge Robert Holmes Bell	Closed: 09/08/2010
Referred To:	Statute: 28:1338
Nature of suit: Patent (830)	Jury Demand: None
Cause: Patent Infringement	Demand Amount: \$0
Lead Docket: None	NOS Description: Patent
Other Docket: None	
Jurisdiction: Federal Question	

Litigants

Attorneys

Nartron Corporation
Plaintiff

Robert C.J. Tuttle
ATTORNEY TO BE NOTICED
Brooks Kushman PC
1000 Town Ctr., 22nd Fl.
Southfield, MI 48075-1238
USA
(248) 358-4400
Fax: (248) 358-3351
Email: Rtuttle@brookskushman.Com

Uusi, Llc
Plaintiff

Robert C.J. Tuttle
ATTORNEY TO BE NOTICED
Brooks Kushman PC
1000 Town Ctr., 22nd Fl.
Southfield, MI 48075-1238
USA
(248) 358-4400
Fax: (248) 358-3351
Email: Rtuttle@brookskushman.Com

Byron Hourmand
Defendant

Date	#	Proceeding Text	Source
07/20/2010	1	COMPLAINT against Byron Hourmand filed by Nartron Corporation, UUSI, LLC (Attachments: # 1 Exhibit A, # 2 Exhibit B, # 3 Exhibit C, # 4 Exhibit D, # 5 Exhibit E, # 6 Exhibit F, # 7 Exhibit G, # 8 Exhibit H, # 9 Exhibit I, # 10 Exhibit J, # 11 Exhibit K, # 12 Civil Cover Sheet)(rmw) (Entered: 07/21/2010)	

07/20/2010 RECEIPT: in the amount of \$350.00, receipt number GR020949; for filing fees (rmw) (Entered: 07/21/2010)

07/20/2010 SUMMONS ISSUED as to defendant Byron Hourmand (rmw) (Entered: 07/21/2010)

07/20/2010 2 CORPORATE DISCLOSURE STATEMENT by Nartron Corporation (rmw) (Entered: 07/21/2010)

07/20/2010 3 CORPORATE DISCLOSURE STATEMENT by UUSI, LLC (rmw) (Entered: 07/21/2010)

07/21/2010 4 REPORT from the Clerk, WDMI, to the Director of the U.S. Patent and Trademark Office on the filing of a PATENT ACTION (rmw) (Entered: 07/21/2010)

08/16/2010 5 SUMMONS returned executed; Byron Hourmand served on 8/4/2010, answer due 8/25/2010 (Brandenburg, Robert) (Entered: 08/16/2010)

08/16/2010 6 SUMMONS returned executed; Byron Hourmand served on 7/27/2010, answer due 8/25/2010 (Brandenburg, Robert) (Entered: 08/16/2010)

09/01/2010 7 UNOPPOSED MOTION to approve consent judgment by plaintiffs Nartron Corporation, UUSI, LLC; (Tuttle, Robert) (Entered: 09/01/2010)

09/08/2010 8 ORDER granting 7 motion to approve consent judgment ; signed by Judge Robert Holmes Bell (Judge Robert Holmes Bell, kcb) (Entered: 09/08/2010)

09/09/2010 9 REPORT from the Clerk, WDMI, to the Director of the U.S. Patent and Trademark Office on the determination of a PATENT ACTION (gjf) (Entered: 09/09/2010)

Copyright © 2014 LexisNexis CourtLink, Inc. All rights reserved.
*** THIS DATA IS FOR INFORMATIONAL PURPOSES ONLY ***

US District Court Civil Docket

U.S. District - Pennsylvania Middle
(Harrisburg)

1:06cv1777

Org, Ltd., A/ K/ A Quantum Research Group, Ltd. v. Nartron Corporation

This case was retrieved from the court on Sunday, January 26, 2014

Date Filed: 09/12/2006	
Assigned To: Honorable Sylvia H. Rambo	
Referred To:	Class Code: CLOSED
Nature of suit: Patent (830)	Closed: 11/28/2007
Cause: Declaratory Judgement	Statute: 28:2201
Lead Docket: None	Jury Demand: Both
Other U.S. District Court, Western Docket: District of PA, 2:06-CV-500	Demand Amount: \$0
Jurisdiction: Federal Question	NOS Description: Patent

Litigants

Attorneys

Org, Ltd.
a/k/a Quantum Research Group, Ltd.
Plaintiff

Andrew E. Falsetti
LEAD ATTORNEY; ATTORNEY TO BE NOTICED
[Term: 10/23/2007]
Reed Smith LLP
435 Sixth Avenue
Pittsburgh, PA 15219
USA
412-288-3844
Email: Afalsetti@reedsmith.Com

Clay P. Hughes
LEAD ATTORNEY; ATTORNEY TO BE NOTICED
Reed Smith
435 Sixth Avenue
Pittsburgh, PA 15219
USA
412.288.3008
Email: Chughes@reedsmith.Com

Gene A. Tabachnick
LEAD ATTORNEY; ATTORNEY TO BE NOTICED
Reed Smith LLP
435 Sixth Avenue
Pittsburgh, PA 15219
USA
412-288-3258
Email: Gtabachnick@reedsmith.Com

Robert B. Hoffman

Nartron Corporation
Defendant

LEAD ATTORNEY; ATTORNEY TO BE NOTICED
Eckert Seamans Cherin & Mellott, LLC
213 Market Street, 8th Floor
Harrisburg , PA 17101
USA
(717) 237-7182
Email: Rhoffman@eckertseamans.Com

Mark D. Chuey
LEAD ATTORNEY; ATTORNEY TO BE NOTICED
Brooks Kushman P.C.
1000 Town Center 22nd Floor
Southfield , MI 48075-1238
USA
248-358-4400
Email: Mchuey@brookskushman.Com

Mark A. Grace
LEAD ATTORNEY; ATTORNEY TO BE NOTICED
Cohen & Grigsby PC
11 Stanwix Street 15th Floor
Pittsburgh , PA 15222-1319
USA
412-297-4900
Email: Mgrace@cohenlaw.Com

Robert C.J. Tuttle
LEAD ATTORNEY; ATTORNEY TO BE NOTICED
Brooks Kushman P.C.
1000 Town Center 22nd Floor
Southfield , MI 48075-1238
USA
248-358-4400
Email: Rtuttle@brookskushman.Com

Thomas C. Wettach
LEAD ATTORNEY; ATTORNEY TO BE NOTICED
Cohen & Grigsby, PC
11 Stanwix Street 15th Floor
Pittsburgh , PA 15222
USA
412-297-4900
Email: Twettach@cohenlaw.Com

Jill L. Bradley
ATTORNEY TO BE NOTICED
Cohen & Grigsby, P.C.
625 Liberty Avenue
Pittsburgh , PA 15222-3152
USA
412-297-4707
Email: Jbradley@cohenlaw.Com

Nartron Corporation
Counterclaim Plaintiff

Mark D. Chuey
LEAD ATTORNEY; ATTORNEY TO BE NOTICED
Brooks Kushman P.C.
1000 Town Center 22nd Floor
Southfield , MI 48075-1238
USA

248-358-4400
Email: Mchuey@brookskushman.Com

Mark A. Grace
LEAD ATTORNEY; ATTORNEY TO BE NOTICED
Cohen & Grigsby PC
11 Stanwix Street 15th Floor
Pittsburgh , PA 15222-1319
USA
412-297-4900
Email: Mgrace@cohenlaw.Com

Robert C.J. Tuttle
LEAD ATTORNEY; ATTORNEY TO BE NOTICED
Brooks Kushman P.C.
1000 Town Center 22nd Floor
Southfield , MI 48075-1238
USA
248-358-4400
Email: Rtuttle@brookskushman.Com

Thomas C. Wettach
LEAD ATTORNEY; ATTORNEY TO BE NOTICED
Cohen & Grigsby, PC
11 Stanwix Street 15th Floor
Pittsburgh , PA 15222
USA
412-297-4900
Email: Twettach@cohenlaw.Com

Jill L. Bradley
ATTORNEY TO BE NOTICED
Cohen & Grigsby, P.C.
625 Liberty Avenue
Pittsburgh , PA 15222-3152
USA
412-297-4707
Email: Jbradley@cohenlaw.Com

Qrg, Ltd.
Counterclaim Defendant

Andrew E. Falsetti
LEAD ATTORNEY; ATTORNEY TO BE NOTICED
[Term: 10/23/2007]
Reed Smith LLP
435 Sixth Avenue
Pittsburgh , PA 15219
USA
412-288-3844
Email: Afalsetti@reedsmith.Com

Clay P. Hughes
LEAD ATTORNEY; ATTORNEY TO BE NOTICED
Reed Smith
435 Sixth Avenue
Pittsburgh , PA 15219
USA
412.288.3008
Email: Chughes@reedsmith.Com

Gene A. Tabachnick
LEAD ATTORNEY; ATTORNEY TO BE NOTICED

Reed Smith LLP
 435 Sixth Avenue
 Pittsburgh , PA 15219
 USA
 412-288-3258
 Email: Gtabachnick@reedsmith.Com

Robert B. Hoffman
 LEAD ATTORNEY; ATTORNEY TO BE NOTICED
 Eckert Seamans Cherin & Mellott, LLC
 213 Market Street, 8th Floor
 Harrisburg , PA 17101
 USA
 (717) 237-7182
 Email: Rhoffman@eckertseamans.Com

Date	#	Proceeding Text	Source
09/12/2006	1	Case transferred in from District of Western District of Pennsylvania; Case Number 2:06-CV-500. Original file with documents numbered 1-17, certified copy of transfer order and docket sheet received., filed by QRG, LTD.. (Attachments: # 1 Civil Cover Sheet # 2 Receipt# 3 Doc. 2- Disclosure Statement# 4 Doc. 3- Summons# 5 Doc. 4- Motion to Dismiss# 6 Proposed Order to Motion to Dismiss# 7 Doc. 5- Brief in Support to Motion to Dismiss# 8 Exhibit A# 9 Exhibit B# 10 Exhibit C# 11 Doc. 6- Notice of Appearance by Thomas C. Wettach# 12 Doc. 7- Notice; Response to Motion to Dismiss# 13 Doc. 8- Motion for Discovery# 14 Proposed Order for Motion for Discovery# 15 Exhibit 1# 16 Exhibit 2# 17 Exhibit 3# 18 Exhibit 4# 19 Exhibit 6# 20 Exhibit 7# 21 Exhibit 8# 22 Exhibit 9# 23 Exhibit 5 (Motion for Discovery)# 24 Doc. 9- Notice: Response to Motion for Discovery# 25 Doc. 10- Brief in Opp. to Motion for Discovery# 26 Exhibit A (Brief in Opp. to Discovery)# 27 Exhibit B (Brief in Opp. to Discovery)# 28 Exhibit C (Brief in Opp. for Discovery)# 29 Exhibit D- (Brief in Opp. to Discovery)# 30 Doc. 11- Order Granting Motion for Discovery# 31 Doc. 12- Brief in Opp. to Motion to Dismiss# 32 Exhibit A (Brief in Opp. to Motion to Dismiss)# 33 Exhibit B (Brief in Opp. to Motion to Dismiss)# 34 Exhibit C (Brief in Opp. to Motion to Dismiss)# 35 Declaration of Richard T. Ting# 36 Declaration of Andrew E. Falsetti# 37 Declaration of Harald Philipp# 38 Declaration of Chris Bede# 39 Doc. 3 - Motion for Leave to File a Brief in Reply# 40 Exhibit A (Motion to File Brief in Reply)# 41 Doc. 14- Response to Motion for Leave to File a Brief in Reply# 42 Supplemental Declaration of Richard Ting# 43 Doc. 15-Order Granting Motion to File Brief in Reply# 44 Doc. 16- Brief in Reply# 45 Exhibit A (Brief in Reply)# 46 Doc. 17- Order Denying Motion to Dismiss. ADDITIONAL ATTACHMENTS ADDED-TRANSFER LETTER AND DOCKET FROM WESTERN DISTRICT OF PA(s) added on 9/13/2006 (crh,). (Entered: 09/13/2006)	
09/13/2006		SPECIAL ADMISSION FORM SENT to Andrew E. Falsetti, Mark A. Grace & Thomas C. Wettach (crh,) (Entered: 09/13/2006)	
09/13/2006	2	Transfer Letter to Counsel (crh,) (Entered: 09/13/2006)	
09/20/2006	3	NOTICE:A Case Mgmnt Conf has been set for 10/24/2006 @ 9:15 AM before Honorable Sylvia H. Rambo. This conference is by phone and the call is to initiated by the pltf. unless otherwise agreed upon. A joint case mgmnt plan is to be filed n/l/t 10/17/06.(ma,) (Entered: 09/20/2006)	
09/21/2006	4	PETITION FOR SPECIAL ADMISSION (PRO HAC VICE) by Andrew E. Falsetti on behalf of QRG, LTD. Attorney Andrew E. Falsetti is seeking special admission. Filing Fee: 25.00 Receipt Number: 111 146455 (Attachments: # 1 Receipt) (jc) (Entered: 09/21/2006)	

- 09/21/2006 5 PETITION FOR SPECIAL ADMISSION (PRO HAC VICE) by Gene A. Tabachnick on behalf of QRG, LTD. Attorney Gene A. Tabachnick is seeking special admission. Filing Fee: 25.00 Receipt Number: 111 146455 (Attachments: # 1 Receipt) (jc) (Entered: 09/21/2006)
- 09/21/2006 6 NOTICE of Appearance by Robert B. Hoffman on behalf of QRG, LTD. (Hoffman, Robert) (Entered: 09/21/2006)
- 09/22/2006 7 SPECIAL ADMISSIONS FORM APPROVED as to Andrew Falsetti, Esq. on behalf of ORG, LTDSigned by Judge Sylvia H. Rambo on 09/22/06. (ma,) (Entered: 09/22/2006)
- 09/22/2006 8 SPECIAL ADMISSIONS FORM APPROVED as to Gene Tabachnick, Esq. on behalf of QRG, LTDSigned by Judge Sylvia H. Rambo on 09/22/06. (ma,) (Entered: 09/22/2006)
- 09/29/2006 9 PETITION FOR SPECIAL ADMISSION (PRO HAC VICE) by Mark D. Chuey on behalf of NARTRON CORPORATION Attorney Mark D. Chuey is seeking special admission. Filing Fee: 25.00 Receipt Number: 111 146486 (crh,) (Entered: 09/29/2006)
- 09/29/2006 10 PETITION FOR SPECIAL ADMISSION (PRO HAC VICE) by Robert C.J. Tuttle on behalf of NARTRON CORPORATION Attorney Robert C.J. Tuttle is seeking special admission. Filing Fee: 25.00 Receipt Number: 111 146485. (crh,) (Entered: 09/29/2006)
- 10/02/2006 11 SPECIAL ADMISSIONS FORM APPROVED as to Mark D. Chuey, Esq. on behalf of Nartron/Signed by Judge Sylvia H. Rambo on 10/02/06. (ma,) (Entered: 10/02/2006)
- 10/02/2006 12 SPECIAL ADMISSIONS FORM APPROVED as to Robert Tuttle, Esq. on behalf of Nartron.Signed by Judge Sylvia H. Rambo on 10/02/06. (ma,) (Entered: 10/02/2006)
- 10/06/2006 13 ANSWER to Complaint by NARTRON CORPORATION. (Attachments: # 1 Exhibit(s) A# 2 Exhibit(s) B)(Bradley, Jill) (Entered: 10/06/2006)
- 10/17/2006 14 CASE MANAGEMENT PLAN by QRG, LTD.. (Falsetti, Andrew) (Entered: 10/17/2006)
- 10/18/2006 15 PETITION FOR SPECIAL ADMISSION (PRO HAC VICE) by Mark A. Grace on behalf of NARTRON CORPORATION Attorney Mark A. Grace is seeking special admission. Filing Fee: 25.00 Receipt Number: 111 146621. (crh,) (Entered: 10/18/2006)
- 10/18/2006 16 PETITION FOR SPECIAL ADMISSION (PRO HAC VICE) by Thomas C. Wettach on behalf of NARTRON CORPORATION Attorney Thomas C. Wettach is seeking special admission. Filing Fee: 25.00 Receipt Number: 111 146621. (crh,) (Entered: 10/18/2006)
- 10/19/2006 17 SPECIAL ADMISSIONS FORM APPROVED as to Mark Grace, Esq. on behalf of NartronSigned by Judge Sylvia H. Rambo on 10/19/06. (ma,) (Entered: 10/19/2006)
- 10/19/2006 18 SPECIAL ADMISSIONS FORM APPROVED as to Thomas Wettach, Esq. on behalf of NartronSigned by Judge Sylvia H. Rambo on 10/19/06. (ma,) (Entered: 10/19/2006)
- 10/24/2006 20 ORDER - STANDARD CASE MANAGEMENT TRACK Case placed on the 08/2007 trial list. Cases on this list are scheduled to begin on 9/4/2007 following all j/s's starting at 9:30 AM. A date certain may be discussed at the PTC which is set for 8/17/2007 @ 1:30 PM; Discovery due by 2/28/2007. Dispositive Mtns due by 6/20/2007. PTMs due by 8/10/2007. See order for other ddls. Signed by Judge Sylvia H. Rambo on 10/24/06. (ma,) (Entered: 10/24/2006)
- 11/01/2006 21 MOTION to Dismiss Pursuant to Fed.R.Civ.P. 12(b)(1) by NARTRON CORPORATION. (Attachments: # 1 Certificate of Compliance With Local Rule 7.1# 2 Proposed Order)(Grace, Mark) (Entered: 11/01/2006)

- 11/01/2006 22 BRIEF IN SUPPORT re 21 MOTION to Dismiss Pursuant to Fed.R.Civ.P. 12(b)(1) filed by NARTRON CORPORATION. (Attachments: # 1 Declaration of John E. Nemazi# 2 Exhibit(s) A - G)(Grace, Mark) (Entered: 11/01/2006)
- 11/16/2006 23 BRIEF IN OPPOSITION re 21 MOTION to Dismiss Pursuant to Fed.R.Civ.P. 12(b)(1) filed by QRG, LTD.. (Attachments: # 1 Affidavit / Declaration of Harald Philipp# 2 Exhibit(s) 1# 3 Exhibit(s) 2# 4 Exhibit(s) 3# 5 Exhibit(s) 4# 6 Exhibit(s) 5# 7 Exhibit(s) 6# 8 Exhibit(s) 7)(Falsetti, Andrew) (Entered: 11/16/2006)
- 11/27/2006 24 REPLY BRIEF re 21 MOTION to Dismiss Pursuant to Fed.R.Civ.P. 12(b)(1) filed by NARTRON CORPORATION. (Attachments: # 1 Exhibit(s) 1)(Grace, Mark) (Entered: 11/27/2006)
- 11/30/2006 25 MOTION to Clarify The Case Caption by QRG, LTD.. (Attachments: # 1 Certificate of Compliance with Local Rule 7.1# 2 Proposed Order)(Falsetti, Andrew) (Entered: 11/30/2006)
- 12/01/2006 26 BRIEF IN SUPPORT re 25 MOTION to Clarify The Case Caption filed by QRG, LTD..(Falsetti, Andrew) (Entered: 12/01/2006)
- 12/01/2006 27 ORDER deferring ruling on Motion to Clarify 25 pending decision on dft's mtn to dismissSigned by Judge Sylvia H. Rambo on 12/01/06 (ma,) (Entered: 12/01/2006)
- 02/12/2007 29 NOTICE by QRG, LTD. of Dismissal of Related Action (Attachments: # 1 Appendix Eastern District of Michigan Order and Opinion Granting Motion to Dismiss)(Falsetti, Andrew) (Entered: 02/12/2007)
- 03/02/2007 30 MEMORANDUM AND ORDER: Denying in part dft's mtn to dismiss 21 as follows: a) The Court will reserve ruling with regard to the "capacitivetouch sensor products and related components" issue and grant Pltf lv to amend the complaint on or before 4/2/07.b) Mtn is denied in all other respects.2) Pltf's Mtn to Clarify the Case Caption 25 is GRANTED. The Clrk shall change the case caption as to pltf to read: "QRG, Ltd., a/k/a Quantum Research Group, Ltd., Plaintiff." All future filings shall display this caption. 3) An amended cmo will follow.Signed by Judge Sylvia H. Rambo on 03/02/07 (ma,) (Entered: 03/02/2007)
- 03/02/2007 31 AMENDED CASE MANAGEMENT ORDER: J/S and Trial continued to the 10/1/2007 list beginning at 9:30 AM before Honorable Sylvia H. Rambo. Discovery due by 3/30/2007. Dispositive Mts ddl 7/20/2007. PTMs due by 9/7/2007. PTC rescheduled for 9/14/2007 @ 10:00 AM before Honorable Sylvia H. Rambo. See order for other ddls.Signed by Judge Sylvia H. Rambo on 03/02/07. (ma,) (Entered: 03/02/2007)
- 03/08/2007 32 AMENDED COMPLAINT against NARTRON CORPORATION, filed by QRG, LTD..(Falsetti, Andrew) (Entered: 03/08/2007)
- 03/19/2007 33 ANSWER to Amended Complaint, COUNTERCLAIM against all defendants by NARTRON CORPORATION.(Grace, Mark) (Entered: 03/19/2007)
- 03/20/2007 Correction made to docket sheet to reflect QRG, LTD. as the Counterclaim Defendant with appropriate counsel listed as per the 3/19/07 Amended Complaint and Counterclaim 33 . (dfm) (Entered: 03/20/2007)
- 03/23/2007 34 MOTION to Strike Counterclaim by QRG, LTD.. (Attachments: # 1 Exhibit(s) A# 2 Exhibit(s) B# 3 Exhibit(s) C# 4 Exhibit(s) D# 5 Brief in Support# 6 Proposed Order)(Falsetti, Andrew) (Entered: 03/23/2007)
- 03/26/2007 35 BRIEF IN SUPPORT re 34 MOTION to Strike Counterclaim filed by QRG, LTD..(Falsetti, Andrew) (Entered: 03/26/2007)
- 03/29/2007 36 REPLY BRIEF re 34 MOTION to Strike Counterclaim filed by NARTRON CORPORATION. (Attachments: # 1 Exhibit(s) A# 2 Exhibit(s) B# 3 Exhibit(s) C - Part 1# 4 Exhibit(s) C - Part 2# 5 Exhibit(s) D# 6 Exhibit(s) E# 7 Exhibit(s) F# 8 Exhibit(s) G# 9 Exhibit(s) H# 10 Exhibit(s) I)(Grace, Mark) (Entered: 03/29/2007)

- 03/29/2007 37 CERTIFICATE of of Compliance by NARTRON CORPORATION re 36 Reply Brief,. (Grace, Mark) (Entered: 03/29/2007)
- 04/12/2007 38 REPLY BRIEF re 34 MOTION to Strike Counterclaim filed by QRG, LTD.. (Falsetti, Andrew) (Entered: 04/12/2007)
- 04/23/2007 39 MEMORANDUM AND ORDER denying pltf's Motion to Strike 34 .Signed by Judge Sylvia H. Rambo on 04/23/07 (ma,) (Entered: 04/23/2007)
- 04/23/2007 40 NOTICE: A scheduling Conference has been scheduled for 5/10/2007 @ 9:00 AM before Honorable Sylvia H. Rambo. This conference is by phone with the call to be initiated by the pltf.Signed by Judge Sylvia H. Rambo on 04/23/07. (ma,) (Entered: 04/23/2007)
- 05/07/2007 41 REPLY/ ANSWER to Counterclaim for Patent Infringement by QRG, LTD.. (Falsetti, Andrew) (Entered: 05/07/2007)
- 05/07/2007 42 MOTION for Partial Summary Judgment on Plaintiff QRG's Declaratory Judgment Claim for Unenforceability of The Five Nartron Patents-In-Suit by NARTRON CORPORATION.(Grace, Mark) (Entered: 05/07/2007)
- 05/07/2007 43 STATEMENT OF FACTS re 42 MOTION for Partial Summary Judgment on Plaintiff QRG's Declaratory Judgment Claim for Unenforceability of The Five Nartron Patents-In-Suit filed by NARTRON CORPORATION. (Attachments: # 1 Index of Exhibits# 2 Exhibit(s) A# 3 Exhibit(s) B# 4 Exhibit(s) C) (Grace, Mark) (Entered: 05/07/2007)
- 05/07/2007 44 BRIEF IN SUPPORT re 42 MOTION for Partial Summary Judgment on Plaintiff QRG's Declaratory Judgment Claim for Unenforceability of The Five Nartron Patents-In-Suit filed by NARTRON CORPORATION.(Grace, Mark) (Entered: 05/07/2007)
- 05/07/2007 45 EXHIBIT A to Brief in Support by NARTRON CORPORATION re 44 Brief in Support. (Grace, Mark) (Entered: 05/07/2007)
- 05/07/2007 46 EXHIBIT PROPOSED ORDER by NARTRON CORPORATION re 42 MOTION for Partial Summary Judgment on Plaintiff QRG's Declaratory Judgment Claim for Unenforceability of The Five Nartron Patents-In-Suit. (Grace, Mark) (Entered: 05/07/2007)
- 05/07/2007 47 MOTION for Partial Summary Judgment that the Nartron Patents-In-Suit Are Not Invalid by NARTRON CORPORATION. (Attachments: # 1 Proposed Order)(Grace, Mark) (Entered: 05/07/2007)
- 05/07/2007 48 STATEMENT OF FACTS re 47 MOTION for Partial Summary Judgment that the Nartron Patents-In-Suit Are Not Invalid filed by NARTRON CORPORATION. (Attachments: # 1 Index# 2 Exhibit(s) A# 3 Exhibit(s) B# 4 Exhibit(s) C# 5 Exhibit(s) D# 6 Exhibit(s) E)(Grace, Mark) (Entered: 05/07/2007)
- 05/07/2007 49 BRIEF IN SUPPORT re 47 MOTION for Partial Summary Judgment that the Nartron Patents-In-Suit Are Not Invalid filed by NARTRON CORPORATION. (Attachments: # 1 Exhibit(s) A)(Grace, Mark) (Entered: 05/07/2007)
- 05/08/2007 50 CERTIFICATE of Compliance with Word-Count Limit by NARTRON CORPORATION re 44 Brief in Support. (Grace, Mark) (Entered: 05/08/2007)
- 05/08/2007 51 CERTIFICATE of Compliance with Word-Count Limit by NARTRON CORPORATION re 49 Brief in Support. (Grace, Mark) (Entered: 05/08/2007)
- 05/08/2007 Pursuant to the Local Rules and ECF User Manual, all motions and briefs should be filed simultaneously with their corresponding proposed orders, exhibits and any certificates as attachments to the main documents and not as individual documents. (dfm) (Entered: 05/08/2007)
- 05/10/2007 54 ORDER: 1) The fact discovery ddl shall be ext'd to (90) daysfrom the date of this order;2) W/i (30) days of this order, the parties shall depose

Mr. Ingraham, an inventor; 3) W/i (30) days of this order, the parties shall jointly determine whether the issues and patents involved in this case can be narrowed; 4) A telephonic status conference shall take place on 6/26/07, at 9:30 a.m. Pltf shall initiate the call; 5) Briefing of Nartrons two partial mtns for sum jgm (Docs. 42 and 47) is STAYED until 8/17/07. On or before that date, Nartron shall notify the crt and QRG whether it intends to rely upon the mtns as they are, or withdraw the mtns and file a new dispositive mtn. If Nartron elects to file a new dispositive mtn, it must do so by 8/17/07. If Nartron leaves the mtns as they are, briefing will resume in accord w/LRs and QRGs responses will be due on or before 9/4/07; 6) The case management deadlines are amended as follows: Jury Selection/Trial Date December 3, 2007 @ 9:30 AM Fact Discovery Ddl 8/10/07; Amended Dispositive Mtns & Brsups 08/17/07; Pltfs Expert Reports 08/24/07; Dfts Expert Reports 09/7/07; Supplemental Reports 09/21/07; Mtns in Limine & Brsups 10/09/07; Mtns in Limine Response 10/19/07; Mtns in Limine Reply 10/26/07; P-T Conference 11/16/07 @ 11:00 AM; P-T Memoranda 11/9/07; Signed by Judge Sylvia H. Rambo on 05/10/07. (ma,) (Entered: 05/10/2007)

- 06/14/2007 55 STATUS REPORT to the Court on Narrowing of Issues and Patents Involved, and Request for Order for Mandatory Rule 26(a)(1) Disclosures by the Parties by NARTRON CORPORATION. (Attachments: # 1 Exhibit(s) A# 2 Exhibit(s) B# 3 Exhibit(s) C# 4 Exhibit(s) D)(Grace, Mark) (Entered: 06/14/2007)
- 06/19/2007 56 ORDER: Pltf QRG, Ltd. a/k/a Quantum Research Group, Ltd. shall respond to the points and proposals set forth in Nartrons status report 55 and proposed order no later than July 9, 2007. Signed by Judge Sylvia H. Rambo on 06/19/07. (ma,) (Entered: 06/19/2007)
- 07/09/2007 58 NOTICE by QRG, LTD. in Response to Nartron's Report and Proposed Order (Attachments: # 1 Word-Count Certificate# 2 Proposed Order # 3 Exhibit(s) 1# 4 Exhibit(s) 2# 5 Exhibit(s) 3# 6 Exhibit(s) 4# 7 Exhibit(s) 5# 8 Exhibit(s) 6# 9 Exhibit(s) 8# 10 Exhibit(s) 9# 11 Exhibit(s) 10# 12 Exhibit(s) 11# 13 Exhibit(s) 12# 14 Exhibit(s) 7)(Falsetti, Andrew) (Entered: 07/09/2007)
- 07/13/2007 59 RESPONSE by NARTRON CORPORATION to 58 Notice.. (Attachments: # 1 Exhibit(s) 1-4)(Grace, Mark) (Entered: 07/13/2007)
- 07/27/2007 60 Joint MOTION for Extension of Time to Complete Discovery by QRG, LTD.. (Attachments: # 1 Proposed Order)(Falsetti, Andrew) (Entered: 07/27/2007)
- 08/01/2007 61 MEMORANDUM AND ORDER: 1) The claims and counterclaim in the captioned case are limited to those involving QRGs QProx E2SR, QT110, QT113, QT9701, and QT1106 products, and Nartrons patents U.S. patents: 4,731,548; 4,758,735; 4,831,279; 5,087,825; 5,796,183. All other claims are DISMISSED for lack of subject matter jurisdiction. 2) Defendant Nartron Corporations Motion for Partial Summary Judgment on Plaintiff QRGs Declaratory Judgment Claim for Unenforceability of the Five Nartron Patents-in-Suit 42 and Motion for Partial Summary Judgment that the Nartron Patents-in-Suit are not Invalid 47 are STRICKEN. 3) Disposition of the parties Joint Motion to Revise Case Management Order 60 is deferred pending the outcome of mediation. 4) The parties shall notify the court no later than August 10, 2007, whether they intend to obtain their own mediator or request the court to appoint a mediator. 5) Mediation shall be completed no later than September 14, 2007. Signed by Judge Sylvia H. Rambo on 08/01/07 (ma,) (Entered: 08/01/2007)
- 08/10/2007 62 NOTICE by QRG, LTD. and Nartron Corporation Regarding Mediator Selection (Falsetti, Andrew) (Entered: 08/10/2007)
- 09/26/2007 63 STATUS REPORT by NARTRON CORPORATION. (Grace, Mark) (Entered: 09/26/2007)

- 10/22/2007 64 STATUS REPORT (Joint) by NARTRON CORPORATION. (Grace, Mark)
(Entered: 10/22/2007)
- 10/23/2007 65 PETITION FOR SPECIAL ADMISSION (PRO HAC VICE) by Clay P. Hughes
on behalf of QRG, LTD. Attorney Clay Hughes is seeking special admission.
Filing fee \$ 25, receipt number 1136392.. (Hughes, Clay) (Entered:
10/23/2007)
- 10/23/2007 66 ATTORNEY SUBSTITUTION - Withdrawal and Entry of Attorney
Appearance. Attorney Andrew E. Falsetti terminated. Attorney Clay P.
Hughes and Clay P. Hughes for QRG, LTD. added. (Hughes, Clay)
(Entered: 10/23/2007)
- 10/23/2007 67 SPECIAL ADMISSIONS FORM APPROVED as to Clay Hughes, Esq. on behalf
of QRG Signed by Judge Sylvia H. Rambo on 10/23/07. (ma,) (Entered:
10/23/2007)
- 11/28/2007 68 STIPULATION of Dismissal with Prejudice by NARTRON CORPORATION.
(Grace, Mark) (Entered: 11/28/2007)
- 11/28/2007 69 ORDER APPROVING STIPULATION OF DISMISSAL. Signed by all parties.
Case termed. Signed by Judge Sylvia H. Rambo on 11/28/07. (ma,)
(Entered: 11/28/2007)

Copyright © 2014 LexisNexis CourtLink, Inc. All rights reserved.
*** THIS DATA IS FOR INFORMATIONAL PURPOSES ONLY ***

US District Court Civil Docket

U.S. District - Pennsylvania Western
(Pittsburgh)

2:06cv500

Org, Ltd. v. Nartron Corporation

This case was retrieved from the court on Sunday, January 26, 2014

Date Filed: 04/13/2006	Class Code: CLOSED
Assigned To: Donetta W. Ambrose	Closed: 09/07/2006
Referred To:	Statute: 28:2201
Nature of suit: Patent (830)	Jury Demand: Plaintiff
Cause: Declaratory Judgment	Demand Amount: \$0
Lead Docket: None	NOS Description: Patent
Other Docket: None	
Jurisdiction: Federal Question	

Litigants

Attorneys

Org, Ltd.
Plaintiff

Andrew E. Falsetti
LEAD ATTORNEY
Reed Smith
435 Sixth Avenue
Pittsburgh , PA 15219-1886
USA
(412) 288-3844
Fax: (412) 288-3063
Email: Afalsetti@reedsmith.Com

Nartron Corporation
Defendant

Mark A. Grace
LEAD ATTORNEY; ATTORNEY TO BE NOTICED
Cohen & Grace, LLC
105 Braunlich Dr. Suite 300
Pittsburgh , PA 15237
USA
(412) 680-1266
Email: Mgrace@cohengrace.Com

Thomas C. Wettach
LEAD ATTORNEY; ATTORNEY TO BE NOTICED
Cohen & Grace LLC
105 Braunlich Drive, Suite # 300
Pittsburgh , PA 15237-3351
USA
(412) 847-0300
Email: Twettach@cohengrace.Com

Date	#	Proceeding Text	Source
------	---	-----------------	--------

- 04/13/2006 1 COMPLAINT against NARTRON CORPORATION (Filing fee \$ 350 receipt number 3312.) filed by QRG, LTD.. (Attachments: # 1 Civil Cover Sheet # 2 Receipt # 3312)(jsp) (Entered: 04/14/2006)
- 04/13/2006 2 Disclosure Statement by QRG, LTD. (jsp) (Entered: 04/14/2006)
- 04/14/2006 Summons Issued as to NARTRON CORPORATION. (jsp) (Entered: 04/14/2006)
- 04/14/2006 Remark: E-mail notification to the U.S. Patent and Trademark Office with complaint and docket entries attached sent this date. (jsp,) (Entered: 04/14/2006)
- 04/24/2006 3 SUMMONS/ Return of Service Returned Executed by QRG, LTD.. NARTRON CORPORATION served on 4/18/2006, answer due 5/8/2006. (Tabachnick, Gene) (Entered: 04/24/2006)
- 05/08/2006 4 MOTION to Dismiss Pursuant to Fed.R.Civ.P. 12(b)(2) by NARTRON CORPORATION. (Attachments: # 1 Proposed Order (Grace, Mark) (Entered: 05/08/2006)
- 05/08/2006 5 BRIEF in Support re 4 MOTION to Dismiss Pursuant to Fed.R.Civ.P. 12(b)(2) filed by NARTRON CORPORATION. (Attachments: # 1 Exhibit A# 2 Exhibit B# 3 Exhibit C)(Grace, Mark) (Entered: 05/08/2006)
- 05/09/2006 6 NOTICE of Appearance by Thomas C. Wettach on behalf of NARTRON CORPORATION (Wettach, Thomas) (Entered: 05/09/2006)
- 05/09/2006 7 NOTICE: Response to Defendant's Motion to Dismiss (Docket No. 4) due by 5/30/2006. (jlh) (Entered: 05/09/2006)
- 05/12/2006 8 MOTION for Discovery on Personal Jurisdiction by QRG, LTD.. (Attachments: # 1 Proposed Order # 2 Exhibit 1# 3 Exhibit 2# 4 Exhibit 3# 5 Exhibit 4# 6 Exhibit 5# 7 Exhibit 6# 8 Exhibit 7# 9 Exhibit 8# 10 Exhibit 9)(Falsetti, Andrew) (Entered: 05/12/2006)
- 05/22/2006 9 NOTICE: Response to Plaintiff's Motion for Leave to Take Discovery on the Personal Jurisdiction Issue Raised by Defendant's Motion to Dismiss shall be due by 5/29/2006. In addition, the Plaintiff's response to the Defendant's Motion to Dismiss shall be continued from May 30, 2006 until a date set forth in a future order of this court. (jlh) (Entered: 05/22/2006)
- 05/26/2006 10 BRIEF in Opposition re 8 MOTION for Discovery on Personal Jurisdiction filed by NARTRON CORPORATION. (Attachments: # 1 Exhibit A# 2 Exhibit B# 3 Exhibit C# 4 Exhibit D)(Grace, Mark) (Entered: 05/26/2006)
- 05/30/2006 11 ORDER granting 8 Motion for Discovery (as stated more fully in order). Signed by Judge Donetta W. Ambrose on 5/30/06. (jlh) (Entered: 05/30/2006)
- 05/30/2006 Response to Motion to Dismiss due by 7/30/2006. (jlh) (Entered: 05/30/2006)
- 07/31/2006 12 BRIEF in Opposition re 4 MOTION to Dismiss Pursuant to Fed.R.Civ.P. 12(b)(2) filed by QRG, LTD.. (Attachments: # 1 Exhibit A# 2 Exhibit B# 3 Exhibit C# 4 Affidavit /Declaration of Richard T. Ting in Support of Qrg's Oppostion to Defendant's Motion to Dismiss# 5 Affidavit /Declaration of Andrew E. Falsetti in Support of Qrg's Oppostion to Defendant's Motion to Dismiss# 6 Affidavit /Declaration of Harald Philipp in Support of Qrg's Oppostion to Defendant's Motion to Dismiss# 7 Affidavit /Declaration of Chris Bede in Support of QRG's Oppostion to Defendant's Motion to Dismiss)(Falsetti, Andrew) (Entered: 07/31/2006)
- 08/04/2006 13 MOTION for Leave to File A Brief in Reply to Plaintiff QRG's Opposition to Defendant's Motion to Dismiss by NARTRON CORPORATION. (Attachments: # 1 Exhibit A)(Grace, Mark) (Entered: 08/04/2006)
- 08/07/2006 14 RESPONSE to Motion re 13 MOTION for Leave to File A Brief in Reply to Plaintiff QRG's Opposition to Defendant's Motion to Dismiss filed by QRG,

- LTD.. (Attachments: # 1 Affidavit /Supplemental Declaration of Richard T. Ting)(Falsetti, Andrew) (Entered: 08/07/2006)
- 08/09/2006 15 ORDER granting 13 Motion for Leave to File Reply Brief . Signed by Judge Donetta W. Ambrose on 8/8/06. (jlh) (Entered: 08/09/2006)
- 08/09/2006 16 BRIEF IN REPLY to Response to Motion re 4 MOTION to Dismiss Pursuant to Fed.R.Civ.P. 12(b)(2) filed by NARTRON CORPORATION. (Attachments: # 1 Exhibit A)(Grace, Mark) Modified text to reflect title of document on 8/10/2006 (jsp,). (Entered: 08/09/2006)
- 09/07/2006 17 ORDER denying 4 Motion to Dismiss, as set forth more fully in the Opinion accompanying this Order; It is further ORDERED that the within case is transferred to the United States District Court for the Middle District of Pennsylvania. The Clerk of Court is directed to transfer this case forthwith to the U.S. District Court for the Middle District of Pennsylvania. Signed by Judge Donetta W. Ambrose, Chief Judge, on 09/07/2006. (adb) (Entered: 09/07/2006)
- 09/07/2006 Case transferred to District of USDC Middle District of PA. Original file, certified copy of transfer order, retrieval instructions and docket sheet sent. (jsp) (Entered: 09/07/2006)
- 09/07/2006 Remark: E-mail notification to the U.S. Patent and Trademark Office with copy of order transferring this action to the USDC for the Middle District of Pennsylvania sent on September 7, 2006. (jsp) (Entered: 09/07/2006)

Copyright © 2014 LexisNexis CourtLink, Inc. All rights reserved.
*** THIS DATA IS FOR INFORMATIONAL PURPOSES ONLY ***

US District Court Civil Docket

U.S. District - Michigan Eastern
(Detroit)

2:03cv75169

Nartron Corp v. Gen Elec, et al

This case was retrieved from the court on Sunday, January 26, 2014

Date Filed: 12/24/2003	
Assigned To: District Judge Nancy G. Edmunds	
Referred To: Magistrate Judge Virginia M. Morgan	Class Code: CLOSED
	Closed: 02/14/2005
Nature of suit: Patent (830)	Statute:
Cause:	Jury Demand: Both
Lead Docket: None	Demand Amount: \$0
Other Docket: None	NOS Description: Patent
Jurisdiction: Federal Question	

Litigants

Attorneys

Nartron Corporation
Plaintiff

Ernie L. Brooks - INACTIVE
LEAD ATTORNEY; ATTORNEY TO BE NOTICED
Brooks Kushman
1000 Town Center 22nd Floor
Southfield , MI 48075
USA
248-358-4400

John E. Nemazi
LEAD ATTORNEY; ATTORNEY TO BE NOTICED
Brooks Kushman
1000 Town Center 22nd Floor
Southfield , MI 48075
USA
248-358-4400
Email: Jnemazi@brookskushman.Com

Sangeeta G. Shah
LEAD ATTORNEY; ATTORNEY TO BE NOTICED
Brooks Kushman
1000 Town Center 22nd Floor
Southfield , MI 48075
USA
248-358-4400
Email: Sshah@brookskushman.Com

Thomas W. Cunningham

General Electric
Defendant

LEAD ATTORNEY; ATTORNEY TO BE NOTICED
Brooks Kushman
1000 Town Center 22nd Floor
Southfield , MI 48075
USA
248-358-4400
Email: Tcunningham@brookskushman.Com

J. Michael Huget
LEAD ATTORNEY; ATTORNEY TO BE NOTICED
Honigman Miller Schwartz and Cohn LLP
130 South First Street 4th Floor
Ann Arbor , MI 48104-1386
USA
734-418-4254
Fax: 734-418-4255
Email: Mhuget@honigman.Com

James W. Stuart
LEAD ATTORNEY
[Term: 03/10/2004]
Ogne, Alberts,
1869 E. Maple Road Suite 100
Troy , MI 48083
USA
248-362-3707
Fax: 248-382-0422
Email: Jstuart@oaspc.Com

Laurie J. Michelson
LEAD ATTORNEY; ATTORNEY TO BE NOTICED
Butzel Long
150 W. Jefferson Suite 100
Detroit , MI 48226-4430
USA
313-225-7000
Email: Orłowski@butzel.Com

Marshall J. Schmitt
LEAD ATTORNEY; ATTORNEY TO BE NOTICED
Jenner and Block
330 N. Wabash Avenue
One Ibm Plaza
Chicago , IL 60611
USA
312-923-2759

Philip J. Kessler
LEAD ATTORNEY; ATTORNEY TO BE NOTICED
Thompson & Knight LLP
2000 Town Center, Suite 1900
Southfield , MI 48075
USA
248-233-0852
Fax: 214-999-1576
Email: Philip.Kessler@tklaw.Com

Stanley A. Schlitter
LEAD ATTORNEY; ATTORNEY TO BE NOTICED
One IBM Plaza

Maytag Corporation
Defendant

Suite 4700
Chicago , IL 60611-7603
USA
312-222-9350

J. Michael Huget
LEAD ATTORNEY; ATTORNEY TO BE NOTICED
Honigman Miller Schwartz and Cohn LLP
130 South First Street 4th Floor
Ann Arbor , MI 48104-1386
USA
734-418-4254
Fax: 734-418-4255
Email: Mhuget@honigman.Com

James W. Stuart
LEAD ATTORNEY
[Term: 03/10/2004]
Ogne, Alberts,
1869 E. Maple Road Suite 100
Troy , MI 48083
USA
248-362-3707
Fax: 248-382-0422
Email: Jstuart@oaspc.Com

Laurie J. Michelson
LEAD ATTORNEY; ATTORNEY TO BE NOTICED
Butzel Long
150 W. Jefferson Suite 100
Detroit , MI 48226-4430
USA
313-225-7000
Email: Orłowski@butzel.Com

Marshall J. Schmitt
LEAD ATTORNEY; ATTORNEY TO BE NOTICED
Jenner and Block
330 N. Wabash Avenue
One Ibm Plaza
Chicago , IL 60611
USA
312-923-2759

Philip J. Kessler
LEAD ATTORNEY; ATTORNEY TO BE NOTICED
Thompson & Knight LLP
2000 Town Center, Suite 1900
Southfield , MI 48075
USA
248-233-0852
Fax: 214-999-1576
Email: Philip.Kessler@tklaw.Com

Stanley A. Schlitter
LEAD ATTORNEY; ATTORNEY TO BE NOTICED
One IBM Plaza
Suite 4700
Chicago , IL 60611-7603
USA

312-222-9350

Touchsensor Technologies, L. L. C.
Defendant

J. Michael Huget
LEAD ATTORNEY; ATTORNEY TO BE NOTICED
Honigman Miller Schwartz and Cohn LLP
130 South First Street 4th Floor
Ann Arbor , MI 48104-1386
USA
734-418-4254
Fax: 734-418-4255
Email: Mhuget@honigman.Com

James W. Stuart
LEAD ATTORNEY
[Term: 03/10/2004]
Ogne, Alberts,
1869 E. Maple Road Suite 100
Troy , MI 48083
USA
248-362-3707
Fax: 248-382-0422
Email: Jstuart@oaspc.Com

Laurie J. Michelson
LEAD ATTORNEY; ATTORNEY TO BE NOTICED
Butzel Long
150 W. Jefferson Suite 100
Detroit , MI 48226-4430
USA
313-225-7000
Email: Orłowski@butzel.Com

Marshall J. Schmitt
LEAD ATTORNEY; ATTORNEY TO BE NOTICED
Jenner and Block
330 N. Wabash Avenue
One Ibm Plaza
Chicago , IL 60611
USA
312-923-2759

Philip J. Kessler
LEAD ATTORNEY; ATTORNEY TO BE NOTICED
Thompson & Knight LLP
2000 Town Center, Suite 1900
Southfield , MI 48075
USA
248-233-0852
Fax: 214-999-1576
Email: Philip.Kessler@tklaw.Com

Stanley A. Schlitter
LEAD ATTORNEY; ATTORNEY TO BE NOTICED
One IBM Plaza
Suite 4700
Chicago , IL 60611-7603
USA
312-222-9350

Touchsensor Technologies, L. L. C.
Counter Claimant

J. Michael Huget
LEAD ATTORNEY; ATTORNEY TO BE NOTICED
Honigman Miller Schwartz and Cohn LLP
130 South First Street 4th Floor
Ann Arbor , MI 48104-1386
USA
734-418-4254
Fax: 734-418-4255
Email: Mhuget@honigman.Com

Laurie J. Michelson
LEAD ATTORNEY; ATTORNEY TO BE NOTICED
Butzel Long
150 W. Jefferson Suite 100
Detroit , MI 48226-4430
USA
313-225-7000
Email: Orłowski@butzel.Com

Marshall J. Schmitt
LEAD ATTORNEY; ATTORNEY TO BE NOTICED
Jenner and Block
330 N. Wabash Avenue
One Ibm Plaza
Chicago , IL 60611
USA
312-923-2759

Philip J. Kessler
LEAD ATTORNEY; ATTORNEY TO BE NOTICED
Thompson & Knight LLP
2000 Town Center, Suite 1900
Southfield , MI 48075
USA
248-233-0852
Fax: 214-999-1576
Email: Philip.Kessler@tklaw.Com

Stanley A. Schlitter
LEAD ATTORNEY; ATTORNEY TO BE NOTICED
One IBM Plaza
Suite 4700
Chicago , IL 60611-7603
USA
312-222-9350

Nartron Corporation
Counter Defendant

Sangeeta G. Shah
ATTORNEY TO BE NOTICED
Brooks Kushman
1000 Town Center 22nd Floor
Southfield , MI 48075
USA
248-358-4400
Email: Sshah@brookskushman.Com

Maytag Corporation
Counter Claimant

J. Michael Huget
LEAD ATTORNEY; ATTORNEY TO BE NOTICED
Honigman Miller Schwartz and Cohn LLP
130 South First Street 4th Floor

Ann Arbor , MI 48104-1386
USA
734-418-4254
Fax: 734-418-4255
Email: Mhuget@honigman.Com

Laurie J. Michelson
LEAD ATTORNEY; ATTORNEY TO BE NOTICED
Butzel Long
150 W. Jefferson Suite 100
Detroit , MI 48226-4430
USA
313-225-7000
Email: Orłowski@butzel.Com

Marshall J. Schmitt
LEAD ATTORNEY; ATTORNEY TO BE NOTICED
Jenner and Block
330 N. Wabash Avenue
One Ibm Plaza
Chicago , IL 60611
USA
312-923-2759

Philip J. Kessler
LEAD ATTORNEY; ATTORNEY TO BE NOTICED
Thompson & Knight LLP
2000 Town Center, Suite 1900
Southfield , MI 48075
USA
248-233-0852
Fax: 214-999-1576
Email: Philip.Kessler@tklaw.Com

Stanley A. Schlitter
LEAD ATTORNEY; ATTORNEY TO BE NOTICED
One IBM Plaza
Suite 4700
Chicago , IL 60611-7603
USA
312-222-9350

Nartron Corporation
Counter Defendant

Sangeeta G. Shah
ATTORNEY TO BE NOTICED
Brooks Kushman
1000 Town Center 22nd Floor
Southfield , MI 48075
USA
248-358-4400
Email: Sshah@brookskushman.Com

General Electric
Counter Claimant

J. Michael Huget
LEAD ATTORNEY; ATTORNEY TO BE NOTICED
Honigman Miller Schwartz and Cohn LLP
130 South First Street 4th Floor
Ann Arbor , MI 48104-1386
USA
734-418-4254
Fax: 734-418-4255

Email: Mhuget@honigman.Com

Laurie J. Michelson
LEAD ATTORNEY; ATTORNEY TO BE NOTICED
Butzel Long
150 W. Jefferson Suite 100
Detroit , MI 48226-4430
USA
313-225-7000
Email: Orłowski@butzel.Com

Marshall J. Schmitt
LEAD ATTORNEY; ATTORNEY TO BE NOTICED
Jenner and Block
330 N. Wabash Avenue
One Ibm Plaza
Chicago , IL 60611
USA
312-923-2759

Philip J. Kessler
LEAD ATTORNEY; ATTORNEY TO BE NOTICED
Thompson & Knight LLP
2000 Town Center, Suite 1900
Southfield , MI 48075
USA
248-233-0852
Fax: 214-999-1576
Email: Philip.Kessler@tklaw.Com

Stanley A. Schlitter
LEAD ATTORNEY; ATTORNEY TO BE NOTICED
One IBM Plaza
Suite 4700
Chicago , IL 60611-7603
USA
312-222-9350

Nartron Corporation
Counter Defendant

Sangeeta G. Shah
ATTORNEY TO BE NOTICED
Brooks Kushman
1000 Town Center 22nd Floor
Southfield , MI 48075
USA
248-358-4400
Email: Sshah@brookskushman.Com

Date	#	Proceeding Text	Source
12/24/2003	1	COMPLAINT for patent infringement and jury demand - Receipt # 36294 - Date Fee Received: 12/24/03 with attachments A-C (DT) (Entered: 12/29/2003)	
12/24/2003		REPORT sent to Washington (DT) (Entered: 12/29/2003)	
12/24/2003	2	STATEMENT of disclosure of corporate affiliations and financial interests by plaintiff Nartron Corp (DT) (Entered: 12/29/2003)	
01/08/2004	3	AMENDED complaint by plaintiff Nartron Corp for patent infringement, with jury, exhibits A-C and proof of service. demand (RH) (Entered: 01/09/2004)	

- 01/14/2004 4 SUMMONS Returned Executed. General Electric served on 1/12/2004, answer due 2/2/2004 (NHoll,) (Entered: 02/03/2004)
- 01/30/2004 7 SUMMONS Returned Executed. Touchsensor Technologies, L. L. C. served on 1/15/2004, answer due 2/4/2004 (NHoll,) (Entered: 02/11/2004)
- 02/02/2004 5 ATTORNEY APPEARANCE: James W. Stuart appearing on behalf of General Electric, Maytag Corporation. (NHoll,) (Entered: 02/11/2004)
- 02/02/2004 6 SUMMONS Returned Executed. Maytag Corporation served on 1/16/2004, answer due 2/5/2004. (NHoll,) (Entered: 02/11/2004)
- 02/04/2004 8 ATTORNEY APPEARANCE: James W. Stuart appearing on behalf of Touchsensor Technologies, L. L. C. (NHoll,) (Entered: 02/12/2004)
- 02/11/2004 9 ANSWER to Amended Complaint with Affirmative Defenses, COUNTERCLAIM filed by Touchsensor Technologies, L. L. C. against Nartron Corporation (NHoll,) (Entered: 02/17/2004)
- 02/11/2004 10 ANSWER to Amended Complaint with Affirmative Defenses, COUNTERCLAIM filed by Maytag Corporation against Nartron Corporation (NHoll,) (Entered: 02/17/2004)
- 02/11/2004 11 ANSWER to Amended Complaint with Affirmative Defenses, COUNTERCLAIM filed by General Electric against Nartron Corporation (NHoll,) (Entered: 02/17/2004)
- 02/18/2004 12 ANSWER to 9 Counterclaim by Nartron Corporation. (NHoll,) Modified on 2/23/2004 (NHoll,). (Entered: 02/23/2004)
- 02/18/2004 13 ANSWER to 11 Counterclaim by Nartron Corporation. (NHoll,) (Entered: 02/23/2004)
- 02/18/2004 14 ANSWER to 10 Counterclaim by Nartron Corporation.(NHoll,) (Entered: 02/24/2004)
- 03/03/2004 16 STATEMENT of DISCLOSURE of CORPORATE AFFILIATIONS and FINANCIAL INTEREST by General Electric (DTyle,) (Entered: 03/16/2004)
- 03/03/2004 17 STATEMENT of DISCLOSURE of CORPORATE AFFILIATIONS and FINANCIAL INTEREST by Maytag Corporation (DTyle,) (Entered: 03/16/2004)
- 03/03/2004 18 STATEMENT of DISCLOSURE of CORPORATE AFFILIATIONS and FINANCIAL INTEREST by Touchsensor Technologies, L. L. C. (DTyle,) (Entered: 03/16/2004)
- 03/04/2004 15 NOTICE TO APPEAR: Scheduling Conference set for 4/1/2004 02:00 PM before Honorable Nancy G Edmunds. (CHem,) (Entered: 03/04/2004)
- 03/10/2004 19 STIPULATED ORDER substituting attorneys Philip J. Kessler, J. Michael Huget and Laurie J. Michelson for Maytag Corporation, Touchsensor Technologies, L. L. C. and General Electric in place of attorney James W. Stuart Signed by Judge Nancy G Edmunds. (DTyle,) (Entered: 03/23/2004)
- 03/30/2004 21 DISCOVERY plan jointly filed pursuant to Federal Rules of Civil Procedure 26(f) (NHoll,) (Entered: 04/14/2004)
- 03/31/2004 22 REVISED DISCOVERY plan jointly filed pursuant to Federal Rules of Civil Procedure 26(f) (NHoll,) (Entered: 04/14/2004)
- 04/06/2004 Minute Entry -Scheduling Conference held on 4/6/2004 before Honorable Nancy G Edmunds. Status Conference set for 7/13/2004 02:00 PM before Honorable Nancy G Edmunds. (CHem,) (Entered: 04/07/2004)
- 04/06/2004 27 SCHEDULING ORDER: Status Conference set for 7/13/2004 02:00 PM before Honorable Nancy G Edmunds. Signed by Honorable Nancy G Edmunds. (Refer to image for additional dates)(CHem,) (Entered: 06/10/2004)
- 04/08/2004 23 STIPULATED PROTECTIVE ORDER Signed by Judge Nancy G Edmunds. (DTyle,) (Entered: 04/22/2004)

- 05/04/2004 24 NOTICE of Appearance by Marshall J. Schmitt, Stanley A. Schlitter on behalf of General Electric, Maytag Corporation, Touchsensor Technologies, L. L. C. (DTyle,) (Entered: 05/06/2004)
- 06/07/2004 (STICKEN 6/10/04) Ex Parte MOTION to Amend/Correct 20 Scheduling Conference, Set Scheduling Order Deadlines by Nartron Corporation. (Attachments: # 1 Index of Exhibits # 2 Exhibit 6/4/04 letter regarding mediation# 3 Exhibit 6/4/04 letter regarding document production)(Shah, Sangeeta) Modified on 6/10/2004 (CHem,). (Entered: 06/07/2004)
- 06/10/2004 26 ORDER to Strike 25 Ex Parte MOTION to Amend/Correct 20 Scheduling Conference, Set Scheduling Order Deadlines filed by Nartron Corporation. Signed by Honorable Nancy G Edmunds. (CHem,) (Entered: 06/10/2004)
- 06/14/2004 28 MOTION to Amend/Correct 27 Scheduling Order by Nartron Corporation. (Attachments: # 1 Index of Exhibits # 2 Exhibit 6/4/04 letter regarding mediator# 3 Exhibit 6/4/04 letter regarding document production)(Shah, Sangeeta) (Entered: 06/14/2004)
- 06/24/2004 29 RESPONSE to 28 Motion to amend scheduling order filed by General Electric, Maytag Corporation and Touchsensor Technologies, L. L. C.; with exhibit A. (DPer,) (Entered: 06/30/2004)
- 07/01/2004 30 REPLY to Response re 28 MOTION to Amend/Correct 27 Scheduling Order filed by Nartron Corporation. (Shah, Sangeeta) (Entered: 07/01/2004)
- 07/13/2004 Minute Entry -Status Conference held on 7/13/2004, parties agreed to special master, before Honorable Nancy G Edmunds. (CHem,) (Entered: 07/21/2004)
- 07/27/2004 31 DECLARATION of compliance by John Robinson Thomas (DTyle,) (Entered: 08/02/2004)
- 07/27/2004 32 AFFIDAVIT of John R. Thomas (DTyle,) (Entered: 08/02/2004)
- 07/29/2004 33 AMENDED SCHEDULING ORDER: Signed by Honorable Nancy G Edmunds. (Refer to image for dates)(DTyle,) (Entered: 08/05/2004)
- 07/29/2004 34 APPOINTMENT AND ORDER of reference to Special Master Signed by Honorable Nancy G Edmunds. (DTyle,) (Entered: 08/05/2004)
- 08/13/2004 35 MOTION to Amend the scheduling order and MOTION to Compel Discovery by Nartron Corporation. (Attachments: # 1 Document Continuation # 2 Document Continuation # 3 Document Continuation # 4 Document Continuation)(DTyle,) (Entered: 08/16/2004)
- 08/19/2004 36 RESPONSE to 35 Motion to Amend scheduling order and Motion to Compel discovery filed by defendants. (DTyle,) (Entered: 08/23/2004)
- 08/31/2004 37 ORDER REFERRING MOTION to Magistrate Judge Komives: 35 MOTION to Amend/Correct MOTION to Compel filed by Nartron Corporation. Signed by Honorable Nancy G Edmunds. (CHem,) (Entered: 08/31/2004)
- 08/31/2004 39 REPLY to Response re 35 MOTION to Amend Scheduling Order and MOTION to Compel filed by Nartron Corporation. (CMul,) (Entered: 09/02/2004)
- 09/02/2004 38 NOTICE of hearing on 35 MOTION to Amend/Correct MOTION to Compel. Motion Hearing set for 9/15/2004 11:00 AM before Honorable Paul J Komives. (SJef,) (Entered: 09/02/2004)
- 09/16/2004 Minute Entry -Motion Hearing held on 9/16/2004 re 35 MOTION to Amend/Correct MOTION to Compel filed by Nartron Corporation before Honorable Paul J Komives. Disposition: TAKEN UNDER ADVISEMENT (Tape # 04-010) (SJef,) (Entered: 09/16/2004)
- 09/23/2004 40 ORDER of DISQUALIFICATION and REASSIGNING CASE from Magistrate Judge Paul J Komives to Magistrate Judge Virginia M Morgan Signed by Honorable Paul J Komives. (SSchoe,) (Entered: 09/24/2004)
- 09/27/2004 41 TRANSCRIPT of Proceedings held on 9/15/04 of plaintiff's motion to amend

- scheduling order and motion to compel discovery (DTyle,) (Entered: 09/28/2004)
- 09/29/2004 42 ORDER Referring Pretrial Matters to Magistrate Judge Virginia M Morgan. Signed by Honorable Nancy G Edmunds. (CHem,) (Entered: 09/29/2004)
- 10/08/2004 43 AMENDED DISCOVERY plan jointly filed pursuant to Federal Rules of Civil Procedure 26(f); with exhibit A. (Attachments: # 1 Document Continuation)(DPer,) (Entered: 10/13/2004)
- 10/27/2004 44 NOTICE of hearing on 35 MOTION to Amend/Correct MOTION to Compel. Resolved/Unresolved Issues due by 11/8/2004. Motion Hearing set for 11/15/2004 10:30 AM before Honorable Virginia M Morgan. (JOwe,) (Entered: 10/27/2004)
- 10/29/2004 45 STATEMENT of Claim Construction Statement by Nartron Corporation. (Attachments: # 1 Index of Exhibits # 2 Exhibit A - Table with Parties' Proposed Constructions)(Shah, Sangeeta) (Entered: 10/29/2004)
- 10/29/2004 46 STATEMENT regarding claim construction by General Electric, Maytag Corporation, Touchsensor Technologies, L. L. C.. (Attachments: # 1 Document Continuation # 2 Document Continuation)(DTyle,) (Entered: 11/01/2004)
- 11/15/2004 Minute Entry -Motion Hearing not held on 11/15/2004 re 35 MOTION to Amend/Correct MOTION to Compel filed by Nartron Corporation before Honorable Virginia M Morgan. Disposition: WITHDRAWN; CASE SETTLED (JOwe,) (Entered: 11/15/2004)
- 11/15/2004 47 ORDER withdrawing 35 Motion to Amend/Correct, withdrawing 35 Motion to Compel- Signed by Honorable Virginia M Morgan. (JOwe,) (Entered: 11/16/2004)
- 11/30/2004 48 STIPULATED ORDER STAYING CASE. Signed by Honorable Nancy G Edmunds. (LBeh,) (Entered: 12/07/2004)
- 02/14/2005 49 STIPULATED ORDER DISMISSING CASE with prejudice Signed by Honorable Nancy G Edmunds. (DTyle,) (Entered: 02/15/2005)

Copyright © 2014 LexisNexis CourtLink, Inc. All rights reserved.
*** THIS DATA IS FOR INFORMATIONAL PURPOSES ONLY ***



Switch Client | Preferences | Help | Sign Out

My Lexis™ Search Get a Document Shepard's® More History Alerts

All

Command Searching > Utility, Design and Plant Patents

Search [View Tutorial](#) | [Help](#)

Select Search Type and Enter Search Terms

<p>Terms & Connectors</p> <p><input type="text" value="patno=5796183"/></p> <p><input type="button" value="Natural Language"/></p> <p><input type="button" value="Easy Search™"/></p> <p><input type="button" value="Semantic Search"/></p> <p><input type="button" value="What's this?"/></p>	<p><input type="text" value="patno=5796183"/></p> <p><input type="button" value="Search"/></p> <p>Suggest terms for my search</p> <p>Check spelling</p>
---	---

Restrict by Document Segment

Select a document segment, enter search terms for the segment, then click Add.

Select a Segment

Note: Segment availability differs between sources. Segments may not be applied consistently across sources.

Restrict by Date

No Date Restrictions From To [Date formats...](#)

<p>Search Connectors</p> <p>and and w/p in same paragraph</p> <p>or or w/seg in same segment</p> <p>w/N within N words w/s in same sentence</p> <p>pre/N precedes by N words and not and not</p> <p>More Connectors & Commands...</p>	<p>How Do I...?</p> <p>Combine sources?</p> <p>Restrict by date?</p> <p>Restrict by document segment?</p> <p>Use wildcards as placeholders for one or more characters in a search term?</p> <p>View Tutorials</p>
---	--

5,796,183 Apr. 29, 2013 Hourmand, et. al.

5,796,183

EX PARTE REEXAMINATION CERTIFICATE C1 (9614th)

Apr. 29, 2013

Capacitive Responsive Electronic Switching Circuit

CORE TERMS: touch, terminal, oscillator, input, output signal, detector, responsive, second touch, electronic switching, capacitive ...

Source: [Command Searching > Utility, Design and Plant Patents](#) 

Terms: **patno=5796183** (Suggest Terms for My Search)

View: KWIC

Date/Time: Sunday, January 26, 2014 - 3:57 PM EST



LexisNexis

[About LexisNexis](#) | [Privacy Policy](#) | [Terms & Conditions](#) | [Contact Us](#)

Copyright © 2014 LexisNexis, a division of Reed Elsevier Inc. All rights reserved.



Switch Client | Preferences | Help | Sign Out

My Lexis™ Search Get a Document Shepard's® More History Alerts

All Add/Edit Subtabs

Command Searching > Patent Cases from Federal Courts and Administrative Materials

Search View Tutorial | Help

Select Search Type and Enter Search Terms

Terms & Connectors	5796183 or 5,796,183	Suggest terms for my search	<input type="button" value="Search"/>
Natural Language			
Easy Search™			

Check spelling

Restrict by Document Segment

Select a document segment, enter search terms for the segment, then click Add.

Select a Segment

Note: Segment availability differs between sources. Segments may not be applied consistently across sources.

Restrict by Date

No Date Restrictions From To Date formats...

<p>Search Connectors</p> <p>and and w/p in same paragraph</p> <p>or or w/seg in same segment</p> <p>w/N within N words w/s in same sentence</p> <p>pre/N precedes by N words and not and not</p> <p>More Connectors & Commands...</p>	<p>How Do I...?</p> <p>Combine sources?</p> <p>Restrict by date?</p> <p>Restrict by document segment?</p> <p>Use wildcards as placeholders for one or more characters in a search term?</p> <p>View Tutorials</p>
--	--



Switch Client | Preferences | Help | Sign Out

My Lexis™	Search	Get a Document	Shepard's®	More	History
					Alerts

FOCUS™ Terms: Search Within: [View Tutorial](#)
 Advanced...

Source: [Command Searching > Patent Cases from Federal Courts and Administrative Materials](#)

Terms: **5796183** or **5,796,183** (Suggest Terms for My Search)

Select for FOCUS™ or Delivery

- 1. QRG, Ltd. v. Nartron Corp., CIVIL NO. 1:06-CV-1777, UNITED STATES DISTRICT COURT FOR THE MIDDLE DISTRICT OF PENNSYLVANIA, 2007 U.S. Dist. LEXIS 55848, August 1, 2007, Decided, August 1, 2007, Filed

CORE TERMS: patent, infringement, declaratory judgment, subject matter jurisdiction, counterclaim, product lines, discovery, status report, identification, apprehension ...

... lines do not infringe U.S. patents: 4,731,548; 4,758,735; 4,831,279; 5,087,825; **5,796,183** ("patents"). Nartron asserts a counterclaim that some of QRG's QProx

... products, and Nartron's patents -- U.S. patents: 4,731,548; 4,758,735; 4,831,279; 5,087,825; **5,796,183**. All other claims are DISMISSED for lack of subject matter ...

- 2. QRG, Ltd. v. Nartron Corp., CIVIL NO. 1:06-CV-1777 , UNITED STATES DISTRICT COURT FOR THE MIDDLE DISTRICT OF PENNSYLVANIA, 2007 U.S. Dist. LEXIS 29725, April 23, 2007, Decided , April 23, 2007, Filed , Claim dismissed by QRG, Ltd. v. Nartron Corp., 2007 U.S. Dist. LEXIS 55848 (M.D. Pa., Aug. 1, 2007)

CORE TERMS: counterclaim, discovery, amend, declaratory judgment, inexcusable delay, infringement, bad faith, futility, patent, product lines ...

... not violate Nartron's patents (U.S. patents: 4,731,548; 4,758,735; 4,831,279; 5,087,825; **5,796,183** ("patents")). Nartron has filed an answer to QRG's amended declaratory ...



- 3. QRG, Ltd. v. Nartron Corp., CIVIL NO. 1:06-CV-1777 , UNITED STATES DISTRICT COURT FOR THE MIDDLE DISTRICT OF PENNSYLVANIA, 513 F. Supp. 2d 149; 2007 U.S. Dist. LEXIS 14782, March 2, 2007, Decided , March 2, 2007, Filed , Motion to strike denied by QRG, Ltd. v. Nartron Corp., 2007 U.S. Dist. LEXIS 29725 (M.D. Pa., Apr. 23, 2007)

OVERVIEW: Court reserved ruling on the holder's motion to dismiss in part, because the competitor's attempt to identify other allegedly infringing products was insufficient to satisfy the second prong of the patent infringement declaratory judgment test; namely, it was unclear what products and components the competitor was referring.

CORE TERMS: patent, apprehension, infringement, declaratory judgment, patent

infringement, prong, patentee's, matter jurisdiction, actual controversy, caption ...



... not violate Nartron's patents (U.S. patents: 4,731,548; 4,758,735; 4,831,279; 5,087,825; **5,796,183** ("patents")). Nartron has filed this motion to dismiss pursuant to Federal Rule of Civil Procedure 12(b)(1) ...

-   4. Nartron Corp. v. Quantum Research Group, Ltd., Case Number 06-13792 , UNITED STATES DISTRICT COURT FOR THE EASTERN DISTRICT OF MICHIGAN, SOUTHERN DIVISION, 473 F. Supp. 2d 790; 2007 U.S. Dist. LEXIS 12373, February 12, 2007, Decided , Related proceeding at QRG, Ltd. v. Nartron Corp., 2007 U.S. Dist. LEXIS 14782 (M.D. Pa., Mar. 2, 2007)

OVERVIEW: Company's motion to dismiss was granted because a prior lawsuit in Pennsylvania involving the same claims between the same parties was filed in a federal court of equal rank and the matter should proceed there. Moreover, the court did not have personal jurisdiction over the company on the basis of Fed. R. Civ. P. 4(k)(2).

CORE TERMS: patent, personal jurisdiction, entity, infringement, website, qprox, declaratory, technology, lawsuit, replies ...

... reads as follows: Re: US patents 4,731,548; 4,758,735; 4,831,279; 5,087,825; **5,796,183** Dear Mr. Phillip: We have recently been made aware of ...

-   5. QRG, Ltd. v. Nartron Corp., Civil Action No. 06-500 , UNITED STATES DISTRICT COURT FOR THE WESTERN DISTRICT OF PENNSYLVANIA, 2006 U.S. Dist. LEXIS 64121, September 7, 2006, Decided , September 7, 2006, Filed , Related proceeding at Nartron Corp. v. Quantum Research Group, Ltd., 2007 U.S. Dist. LEXIS 12373 (E.D. Mich., Feb. 12, 2007)

OVERVIEW: The fact that Michigan patent holder weekly shipped goods to Pennsylvania rendered it subject to general personal jurisdiction in Pennsylvania. Court sua sponte exercised its discretion under 28 U.S.C.S. § 1406(a) and transferred patent declaratory judgment suit to Middle District of Pennsylvania, which was proper venue under 28 U.S.C.S. § 1391(c).

CORE TERMS: personal jurisdiction, continuous, systematic, venue, general jurisdiction, judicial district, reside, asserting, patents, sua sponte ...

... Patent Nos. 4,731,548 ("the '548 Patent"), 4,758,735 ("the '735 Patent"), **5,796,183** ("The '183 Patent"), 4,831,279 ("the '279 Patent"), and 5,087,825 ("the '825 Patent" ...





Source: **Command Searching > Patent Cases from Federal Courts and Administrative Materials** 



Terms: **5796183 or 5,796,183** (Suggest Terms for My Search)

View: Cite

Date/Time: Sunday, January 26, 2014 - 3:58 PM EST

* Signal Legend:

-  - Warning: Negative treatment is indicated
-  - Questioned: Validity questioned by citing refs
-  - Caution: Possible negative treatment
-  - Positive treatment is indicated

-  - Citing Refs. With Analysis Available
 -  - Citation information available
- * Click on any *Shepard's* signal to *Shepardize*[®] that case.



[About LexisNexis](#) | [Privacy Policy](#) | [Terms & Conditions](#) | [Contact Us](#)
Copyright © 2014 LexisNexis, a division of Reed Elsevier Inc. All rights reserved.



Switch Client | Preferences | Help | Sign Out

My Lexis™ Search Get a Document Shepard's® More History Alerts

All Add/Edit Subtabs

Command Searching > Patent, Trademark & Copyright Periodicals, Combined

Search View Tutorial | Help

Select Search Type and Enter Search Terms

Terms & Connectors	5796183 or 5,796,183	Suggest terms for my search Check spelling
Natural Language		
Easy Search™		

Restrict by Document Segment

Select a document segment, enter search terms for the segment, then click Add.

Select a Segment

Note: Segment availability differs between sources. Segments may not be applied consistently across sources.

Restrict by Date

No Date Restrictions From To Date formats...

Search Connectors and and w/p in same paragraph or or w/seg in same segment w/N within N words w/s in same sentence pre/N precedes by N words and not and not More Connectors & Commands...	How Do I...? Combine sources? Restrict by date? Restrict by document segment? Use wildcards as placeholders for one or more characters in a search term? View Tutorials
--	---

No Documents Found

No documents were found for your search terms
"5796183 or 5,796,183"

Click "Save this search as an Alert" to schedule your search to run in the future.

- OR -

Click "Search Using Natural Language" to run your search as Natural Language search.

- OR -

Click "Edit Search" to return to the search form and modify your search.

Suggestions:

- Check for spelling errors.
- Remove some search terms.
- Use more common search terms, such as those listed in "Suggested Words and Concepts."
- Use a less restrictive date range.
- Use "OR" in between terms to search for one term or the other.

Save this Search as an Alert ||| **Search Using Natural Language** ||| **Edit Search** |||





Switch Client | Preferences | Help | Sign Out

My Lexis™ Search Get a Document Shepard's® More History Alerts

All

Command Searching > All English Language News

View Tutorial | Help

Search

Select Search Type and Enter Search Terms

Terms & Connectors	5796183 or 5,796,183	<input type="button" value="Search"/> <p>Suggest terms for my search</p> <p>Check spelling</p>
Natural Language		
Easy Search™		

Restrict by Document Segment

Select a document segment, enter search terms for the segment, then click Add.

Select a Segment

Note: Segment availability differs between sources. Segments may not be applied consistently across sources.

Restrict by Date

No Date Restrictions From To [Date formats...](#)

<p>Search Connectors</p> <p>and and w/p in same paragraph</p> <p>or or w/seg in same segment</p> <p>w/N within N words w/s in same sentence</p> <p>pre/N precedes by N words and not and not</p> <p>More Connectors & Commands...</p>	<p>How Do I...?</p> <p>Combine sources?</p> <p>Restrict by date?</p> <p>Restrict by document segment?</p> <p>Use wildcards as placeholders for one or more characters in a search term?</p> <p>View Tutorials</p>
---	--



Switch Client | Preferences | Help | Sign Out

My Lexis™	Search	Get a Document	Shepard's®	More	History
					Alerts

FOCUS™ Terms Search Within Original Results (1 - 1) [Advanced...](#)

[View Tutorial](#)

Source: [Command Searching > All English Language News](#)

Terms: **5796183 or 5,796,183** ([Suggest Terms for My Search](#))

Cumberland Pharmaceuticals Reports 58% Increase in Net Revenue With Third Quarter 2009 Financial Results; - Caldolor(R) begins generating revenue; - 20% increase in revenue for Acetadote(R) and Kristalose(R); - Profitability maintained through Caldolor(R) launch PR Newswire November 10, 2009 Tuesday 7:30 AM EST

Copyright 2009 PR Newswire Association LLC
All Rights Reserved
PR Newswire

November 10, 2009 Tuesday 7:30 AM EST

LENGTH: 5124 words

HEADLINE: Cumberland Pharmaceuticals Reports 58% Increase in Net Revenue With Third Quarter 2009 Financial Results;
- Caldolor(R) begins generating revenue;
- 20% increase in revenue for Acetadote(R) and Kristalose(R);
- Profitability maintained through Caldolor(R) launch

DATELINE: NASHVILLE, Tenn., Nov. 10

BODY:

NASHVILLE, Tenn., Nov. 10 /PRNewswire-FirstCall/ -- Cumberland Pharmaceuticals Inc. (↖ Nasdaq: CPIX ↗), a specialty pharmaceutical company focused on the hospital acute care and gastroenterology markets, today announced third quarter 2009 financial results.

"With an earlier-than-anticipated Caldolor launch, we were able to dramatically exceed our earnings expectations in the third quarter," said A.J. Kazimi, Chief Executive Officer of Cumberland Pharmaceuticals. "Additionally, the completion of our initial public offering in August provides us with the strongest balance sheet in the history of the Company. We intend to put that capital to good use not only by supporting the Caldolor launch, but also by adding select new products to our portfolio that can benefit patients and enhance shareholder value."

Net Revenue: For the three months ended September 30, 2009, net revenue was \$13.6 million, up 58% from the corresponding period in 2008. This growth was attributable to initial revenue from Caldolor (ibuprofen) Injection, the Company's recently approved IV treatment for pain and fever, as well as an increase in volume for Acetadote (acetylcysteine) Injection, Cumberland's treatment for acetaminophen overdose. Net revenue for the nine months ended September 30, 2009, was \$32.8 million, up 30% from \$25.3 million for the same period in 2008, also primarily due to the Caldolor launch and Acetadote sales growth.

Operating Expenses: Total operating expenses for the three months ended September 30, 2009, were \$11.2 million, compared to \$6.5 million for the same period in 2008. This increase was due primarily to sales and marketing expense associated with the Caldolor launch, higher cost of products sold resulting from sales growth and a change in product mix, as well as a significant, non-recurring payroll tax expense of \$1.0 million related to the exercise of non-qualified options. For the nine-month period ended September 30, 2009, total operating expenses were \$27.7 million, compared with \$19.5 million for the corresponding period in 2008. This increase primarily reflected Caldolor milestone obligations related to FDA approval, the aforementioned payroll tax expense, costs incurred in connection with the Company's hospital sales force expansion, and increased marketing and advertising costs associated with the Caldolor launch.

Net Income: Net income for the three months ended September 30, 2009, grew to \$1.3 million, or \$0.07 per diluted share, compared to \$1.2 million, or \$0.07 per diluted share, for the same period in 2008. Excluding the non-recurring payroll tax expense, net income for the three months ended September 30, 2009, would have increased 54% to \$1.9 million, or \$0.10 per diluted share.

Net income for the nine months ended September 30, 2009, was \$2.8 million, or \$0.16 per diluted share, compared to \$3.7 million, or \$0.22 per diluted share, for the corresponding period in 2008. The decrease is due primarily to milestone obligations triggered by FDA approval of Caldolor in the second quarter of 2009, as well as the aforementioned sales force expansion and option-related payroll tax. Excluding Caldolor milestone payments and the non-recurring payroll tax expense, net income for the nine months ended September 30, 2009, would have grown 25% to \$4.6 million, or \$0.27 per diluted share.

Cash and Cash Equivalents: As of September 30, 2009, Cumberland had \$79.5 million in cash and cash equivalents, a \$67.7 million increase from June 30, 2009. The increase was largely due to the Company's initial public offering in August. At quarter's end, Cumberland had total debt of \$19.8 million, including \$4.5 million in current liabilities. The Company had net accounts receivable and inventories of \$7.3 million and \$1.7 million, respectively, at September 30, 2009.

Third Quarter Highlights

Caldolor Launch

In September 2009, Cumberland successfully launched Caldolor in the U.S., and the Company's hospital and field sales forces comprised of 113 experienced sales professionals are now promoting the product. Caldolor is fully stocked at wholesalers serving hospitals nationwide, and is available in both 400 mg and 800 mg vials. The Company is working to introduce Caldolor and secure formulary approval nationally. The product is now stocked in a number of medical facilities across the country. In addition to personal sales promotion Cumberland is supporting the product through a multi-faceted campaign, including internet and media advertising, medical society and convention presence, journal publications, and its medical information call center, among other initiatives.

Initial Public Offering

In August 2009, Cumberland completed its initial public offering of 5,000,000 shares of common stock at a price to the public of \$17.00 per share, raising \$85.0 million in gross proceeds. Net proceeds to the Company were \$74.8 million after commissions and offering expenses. The proceeds from this offering are being used primarily for potential acquisitions, the launch of Caldolor, expansion of the Company's hospital sales force, product development, debt repayment and general corporate purposes. Cumberland's common stock began trading on the NASDAQ Global Select Market on August 11, 2009, under the trading symbol "CPIX."

Recent Events

International Markets

In October 2009, the Company announced that it has entered into an exclusive agreement with Phebra Pty Ltd., an Australian-based specialty pharmaceutical company, for the commercialization of Caldolor in Australia and New Zealand. Phebra will be responsible for obtaining any regulatory approval for the product, and for handling ongoing regulatory requirements, product marketing, distribution and sales in the territories. Cumberland will maintain responsibility for product formulation, development and manufacturing, and will provide finished product to Phebra. Under the terms of the agreement, Cumberland will receive upfront and milestone payments as well as a transfer price, and will also receive royalties on any future sales of Caldolor in those territories.

New Intellectual Property Initiative for Caldolor

In addition to Cumberland's issued patent for Caldolor, the Company has filed the first of several expected new patent applications for the product. Cumberland's clinical research uncovered several new product-related discoveries, for which the Company filed several provisional patent applications. Part of an ongoing initiative to protect the Company's intellectual property, this new patent application addresses Cumberland's proprietary method of dosing intravenous ibuprofen.

Supplemental Financial Information

The following tables provide a reconciliation of Cumberland's reported (GAAP) statements of income to adjusted (non-GAAP) statements of income for the three- and nine-month periods ended September 30, 2009. The adjusted statements exclude certain non-recurring items, and are provided by management to assist investors in evaluating Cumberland's operating results. The adjusted statements should not be considered a substitute for Cumberland's reported statements of income.

Three Months Ended September 30, 2009	As reported	Adjustments	As adjusted
	-----	-----	-----
Net revenues	\$13,597,760		\$13,597,760
Costs and expenses:			
Cost of products sold	1,761,069		1,761,069
Selling and marketing	6,087,807		6,087,807
Research and development	640,877		640,877
General and administrative	2,537,627	(977,258) (1)	1,560,369
Amortization of product license right	171,726		171,726
Other	26,595		26,595
	-----	-----	-----
Total costs and expenses	11,225,701	(977,258)	10,248,443
	-----	-----	-----
Operating income	2,372,059	977,258	3,349,317
Interest income	14,285		14,285
Interest expense	(248,272)		(248,272)
	-----	-----	-----
Net income before income taxes	2,138,072	977,258	3,115,330
Income tax expense	(855,660)	(403,608) (1)	(1,259,268)
	-----	-----	-----
Net income	1,282,412	573,650	1,856,062
Net loss at subsidiary attributable to noncontrolling interests	5,725		5,725
	-----	-----	-----

Net income attributable to common shareholders	\$1,288,137	573,650	\$1,861,787
	=====	=====	=====
Weighted-average shares outstanding - diluted	19,183,606		19,183,606
Earnings per share - diluted	\$0.07		\$0.10

Notes to reconciliation of reported statement of income to adjusted statement of income:

1. To exclude payroll-related taxes and income tax benefit associated with the exercise of non-qualified options in 2009.

Nine Months Ended September 30, 2009

	As reported	Adjustments	As adjusted
	-----	-----	-----
Net revenues	\$32,822,972		\$32,822,972
Costs and expenses:			
Cost of products sold	3,271,363		3,271,363
Selling and marketing	14,611,796		14,611,796
Research and development	4,041,719	(1,950,362) (1)	2,091,357
General and administrative	5,218,925	(1,093,464) (2)	4,125,461
Amortization of product license right	515,178		515,178
Other	80,791		80,791
	-----	-----	-----
Total costs and expenses	27,739,772	(3,043,826)	24,695,946
	-----	-----	-----
Operating income	5,083,200	3,043,826	8,127,026
Interest income	42,041		42,041
Interest expense	(430,207)		(430,207)
	-----	-----	-----
Net income before income taxes	4,695,034	3,043,826	7,738,860
Income tax expense	(1,919,356)	(1,257,100) (3)	(3,176,456)
	-----	-----	-----
Net income	2,775,678	1,786,726	4,562,404
Net loss at subsidiary attributable to noncontrolling interests	26,420		26,420
	-----	-----	-----
Net income attributable to common shareholders	\$2,802,098	1,786,726	\$4,588,824
	=====	=====	=====
Weighted-average shares outstanding - diluted	17,143,348		17,143,348
Earnings per share - diluted	\$0.16		\$0.27

Notes to reconciliation of reported statement of income to adjusted

statement of income:

1. To exclude milestone expenses associated with the FDA approval of Caldolor.
2. To exclude payroll-related taxes associated with the exercise of non-qualified options in 2009.
3. To include the tax impact of adjustments.

Conference Call and Webcast

A conference call and live webcast will be held on Tuesday, November 10, 2009, at 10:00 a.m. Eastern Time to discuss the Company's third quarter 2009 financial results. To participate on the call, please dial 888-417-8462 (for U.S. callers) or 719-457-2552 (for international callers). A rebroadcast of the teleconference will be available for one week and can be accessed by dialing 888-203-1112 (for U.S. callers) or 719-457-0820 (for international callers). The passcode for the rebroadcast is 9695498. The live webcast and rebroadcast can be accessed via Cumberland Pharmaceuticals' website at <http://investor.shareholder.com/cpix/events.cfm>.

About Cumberland Pharmaceuticals

Cumberland Pharmaceuticals Inc. is a Tennessee-based specialty pharmaceutical company focused on the acquisition, development and commercialization of branded prescription products. The Company's primary target markets include hospital acute care and gastroenterology. Cumberland's product portfolio includes Acetadote® (acetylcysteine) Injection for the treatment of acetaminophen poisoning and Kristalose® (lactulose) for Oral Solution, a prescription laxative. The Company also recently launched Caldolor® (ibuprofen) Injection, the first injectable treatment for pain and fever available in the United States. Cumberland is dedicated to providing innovative products which improve quality of care for patients. The Company completed the initial public offering of its common stock in August 2009. For more information on Cumberland Pharmaceuticals, please visit www.cumberlandpharma.com.

About Caldolor

Caldolor is indicated for the management of mild to moderate pain and management of moderate to severe pain as an adjunct to opioid analgesics, as well as the reduction of fever in adults. It is the first FDA-approved intravenous therapy for fever. Caldolor is contraindicated in patients with known hypersensitivity to ibuprofen or other NSAIDs, patients with asthma, urticaria, or allergic type reactions after taking aspirin or other NSAIDs. Caldolor is contraindicated for use during the peri-operative period in the setting of coronary artery bypass graft (CABG) surgery. Caldolor should be used with caution in patients with prior history of ulcer disease or GI bleeding, in patients with fluid retention or heart failure, in the elderly, those with renal impairment, heart failure, liver impairment, and those taking diuretics or ACE inhibitors. Blood pressure should be monitored during treatment with Caldolor. For full prescribing information, including boxed warning, visit www.caldolor.com.

About Acetadote

Acetadote is used in the emergency department to prevent or lessen potential liver damage resulting from an overdose of acetaminophen, a common ingredient in many over-the-counter painkillers. It is the only approved injectable product in the United States for the treatment of acetaminophen overdose, the leading cause of poisonings presenting in emergency departments in the country(1). Acetadote is contraindicated in patients with hypersensitivity or previous anaphylactoid reactions to acetylcysteine or any components of the preparation. Serious anaphylactoid reactions, including death in a patient with asthma, have been reported in patients administered acetylcysteine intravenously. Acetadote should be used with caution in patients with asthma, or where there is a history of bronchospasm. The total volume administered should be

adjusted for patients less than 40 kg and for those requiring fluid restriction. To avoid fluid overload, the volume of diluent should be reduced as needed. If volume is not adjusted, fluid overload can occur, potentially resulting in hyponatremia, seizure, and death. For full prescribing information, visit www.acefadote.net.

About Kristalose

Kristalose is indicated for the treatment of acute and chronic constipation. It is a unique, proprietary, crystalline form of lactulose, with no restrictions on length of therapy or patient age. Initial dosing may produce flatulence and intestinal cramps, which are usually transient. Excessive dosage can lead to diarrhea with potential complications such as loss of fluids, hypokalemia and hypernatremia. Nausea and vomiting have been reported. Use with caution in diabetics. Kristalose is contraindicated in patients who require a low-galactose diet. Elderly, debilitated patients who receive lactulose for more than six months should have serum electrolytes (potassium, chloride, carbon dioxide) measured periodically. For full prescribing information, visit www.kristalose.com.

Forward Looking Statements

This press release contains "forward-looking statements", including statements regarding estimated results of operations in future periods. These statements are subject to the finalization of Cumberland's quarterly financial and accounting procedures and reflect Cumberland's current views with respect to future events, based on what it believes are reasonable assumptions. No assurance can be given that these events will occur. As with any business, all phases of Cumberland's operations are subject to influences outside its control. Any one or a combination of these factors could materially affect the results of Cumberland's operations. These factors include, among other things, market conditions, commercialization of Caldolor, competition from existing and new products, which could diminish the commercial potential of Cumberland's products, an inability of manufacturers to produce Cumberland's products on a timely basis or a failure of manufacturers to comply with stringent regulations applicable to pharmaceutical manufacturers, maintaining and building an effective sales and marketing infrastructure, Cumberland's ability to identify and acquire rights to products, government regulation, the possibility that Cumberland's marketing exclusivity and patent rights may provide limited protection from competition, and other factors discussed in the Company's Registration Statement declared effective by the SEC on August 10, 2009. There can be no assurance that the results or developments anticipated by the Company will be realized or, even if substantially realized, that they will have the expected effects on the Company's business and operations. Readers are cautioned not to place undue reliance on these forward-looking statements, which speak only as of the date hereof. The Company does not undertake any obligation to release publicly any revisions to these statements to reflect events or circumstances after the date hereof or to reflect the occurrence of unanticipated events.

(1) National Poison Data System, American Association of Poison Control Centers

SOURCE: Cumberland Pharmaceuticals Inc. ▼

CUMBERLAND PHARMACEUTICALS INC. ▼
CONDENSED CONSOLIDATED BALANCE SHEETS
(UNAUDITED)

	December 31, 2008 -----	September 30, 2009 -----
ASSETS		
Current assets:		
Cash and cash equivalents	\$11,829,551	\$79,541,274
Accounts receivable, net of allowances	3,129,347	7,282,371

Inventories	1,762,776	1,687,591
Prepaid and other current assets	481,312	2,536,202
Deferred tax assets	507,212	505,617
	-----	-----
Total current assets	17,710,198	91,553,055
Property and equipment, net	432,413	597,238
Intangible assets, net	8,528,732	8,099,612
Deferred tax assets	1,000,031	990,661
Other assets	3,447,813	415,170
	-----	-----
Total assets	\$31,119,187	\$101,655,736
	=====	=====
LIABILITIES AND EQUITY		
Current liabilities:		
Current portion of long-term debt	\$1,250,000	\$4,500,000
Current portion of other long-term obligations	457,915	204,027
Accounts payable	3,257,164	5,797,596
Other accrued liabilities	2,640,855	3,056,915
	-----	-----
Total current liabilities	7,605,934	13,558,538
Revolving line of credit	1,825,951	1,825,951
Long-term debt, excluding current portion	3,750,000	13,500,000
Other long-term obligations, excluding current portion	382,487	180,652
	-----	-----
Total liabilities	13,564,372	29,065,141
	-----	-----
Commitments and contingencies		
Redeemable common stock	-	1,930,000
Shareholders' equity:		
Cumberland Pharmaceuticals Inc. ▼		
shareholders' equity:		
Convertible preferred stock -		
no par value; 3,000,000 shares		
authorized; 812,749 and 0 shares		
issued and outstanding		
	2,604,070	-
as of December 31, 2008 and		
September 30, 2009, respectively		
Common stock - no par value;		
100,000,000 shares authorized;		
9,903,047 and 20,129,791(1) shares		
issued and outstanding as of		
December 31, 2008 and		
September 30, 2009, respectively		
	13,500,034	66,434,206
Retained earnings	1,450,711	4,252,809

Total shareholders' equity	17,554,815	70,687,015
Noncontrolling interests	--	(26,420)
Total equity	17,554,815	70,660,595
Total liabilities and equity	\$31,119,187	\$101,655,736

(1) Number of shares issued and outstanding represents total shares of common stock regardless of classification on the consolidated balance sheet. The number of shares of redeemable common stock at September 30, 2009 was 119,209.

CUMBERLAND PHARMACEUTICALS INC. ▼
CONDENSED CONSOLIDATED STATEMENTS OF INCOME
(UNAUDITED)

	Three months ended		Nine months ended	
	September 30,		September 30,	
	2008	2009	2008	2009
Net revenues	\$8,602,709	\$13,597,760	\$25,264,068	\$32,822,972
Costs and expenses:				
Cost of products sold	735,492	1,761,069	2,228,213	3,271,363
Selling and marketing	3,620,243	6,087,807	10,629,045	14,611,796
Research and development	730,640	640,877	2,759,042	4,041,719
General and administrative	1,167,687	2,537,627	3,272,420	5,218,925
Amortization of product license right	171,726	171,726	515,178	515,178
Other	26,413	26,595	77,635	80,791
Total costs and expenses	6,452,201	11,225,701	19,481,533	27,739,772
Operating income	2,150,508	2,372,059	5,782,535	5,083,200
Interest income	53,257	14,285	186,276	42,041
Interest expense	(48,647)	(248,272)	(172,628)	(430,207)
Net income before income taxes	2,155,118	2,138,072	5,796,183	4,695,034
Income tax expense	(946,109)	(855,660)	(2,133,501)	(1,919,356)
Net income	1,209,009	1,282,412	3,662,682	2,775,678
Net loss at subsidiary				

attributable to noncontrolling interests	-	5,725	-	26,420
	-----	-----	-----	-----
Net income attributable to common shareholders	\$1,209,009	\$1,288,137	\$3,662,682	\$2,902,098
	=====	=====	=====	=====
Earnings per share attributable to common shareholders - basic	\$0.12	\$0.08	\$0.36	\$0.23
Earnings per share attributable to common shareholders - diluted	\$0.07	\$0.07	\$0.22	\$0.16
Weighted-average shares outstanding - basic	10,165,824	15,745,069	10,128,238	12,197,876
Weighted-average shares outstanding - diluted	16,644,395	19,193,606	16,501,905	17,143,348

CUMBERLAND PHARMACEUTICALS INC. ▼
 CONDENSED CONSOLIDATED STATEMENTS OF CASH FLOWS
 (UNAUDITED)

	Nine Months Ended September 30,	
	-----	-----
	2008	2009
	-----	-----
Cash flows from operating activities:		
Net income	\$3,662,682	\$2,775,678
Adjustments to reconcile net income to net cash flows from operating activities:		
Gain on early extinguishment of other long-term obligations	(38,577)	-
Depreciation and amortization expense	589,721	605,514
Nonemployee stock granted for services received	104,716	205,693
Nonemployee stock option grant expense	-	840,499
Stock-based compensation - employee stock options	274,584	455,502
Excess tax benefit derived from exercise of stock options	(254,681)	(2,842,825)
Noncash interest expense	67,523	83,420
Net changes in assets and liabilities affecting operating activities:		
Accounts receivable	(828,880)	(4,054,710)
Inventory	(849,460)	75,185
Prepaid, other current assets and other assets	849,062	936,286

Accounts payable and other accrued liabilities	613,983	3,299,235
Other long-term obligations	48,681	(455,723)
	-----	-----
Net cash provided by operating activities	4,239,354	1,923,754
	-----	-----
Cash flows from investing activities:		
Additions to property and equipment	(60,996)	(199,312)
Additions to patents	(62,671)	(71,358)
	-----	-----
Net cash used in investment activities	(123,667)	(270,670)
	-----	-----
Cash flows from financing activities:		
Proceeds from initial public offering of common stock	-	85,000,000
Costs of initial public offering	(445,562)	(7,385,124)
Proceeds from borrowings on long-term debt	-	18,000,000
Principal payments on note payable	(1,375,002)	(5,000,000)
Net borrowings on line of credit	500,000	-
Payment of other long-term obligations	(2,760,000)	
Costs of financing for long-term debt and credit facility	-	(189,660)
Proceeds from exercise of stock options	59,097	64,275
Excess tax benefit derived from exercise of stock options	254,681	2,842,825
Payments made in connection with repurchase of common shares	-	(27,273,677)
	-----	-----
Net cash (used in) provided by financing activities	(3,766,786)	66,058,639
	-----	-----
Net increase in cash and cash equivalents	348,901	67,711,723
Cash and cash equivalents at beginning of period	10,814,519	11,829,551
	-----	-----
Cash and cash equivalents at end of period	\$11,163,419	\$79,541,274
	=====	=====

SOURCE Cumberland Pharmaceuticals Inc. ~

CONTACT: investors, Angela Novak, Corporate Relations of Cumberland Pharmaceuticals Inc., + 1-615-255-0068, anovak@cumberlandpharma.com; or Kathy Waller of Financial Relations Board, + 1-312-543-6708; or Media, Paula Lovell of Lovell Communications, + 1-615-297-7766, both for Cumberland Pharmaceuticals Inc. ▼

URL: <http://www.prnewswire.com>

LOAD-DATE: November 11, 2009

Source: [Command Searching > All English Language News](#) 

Terms: **5796183 or 5,796,183** (Suggest Terms for My Search)

View: Full

Date/Time: Sunday, January 26, 2014 - 4:00 PM EST



[About LexisNexis](#) | [Privacy Policy](#) | [Terms & Conditions](#) | [Contact Us](#)
Copyright © 2014 LexisNexis, a division of Reed Elsevier Inc. All rights reserved.

REEXAM CONTROL NUMBER	FILING OR 371 (c) DATE	PATENT NUMBER
90/013,106	12/24/2013	5796183

25962
 SLATER & MATSIL, L.L.P.
 17950 PRESTON RD, SUITE 1000
 DALLAS, TX 75252-5793

CONFIRMATION NO. 9188
REEXAMINATION REQUEST
NOTICE



Date Mailed: 01/15/2014

NOTICE OF REEXAMINATION REQUEST FILING DATE
(Patent Owner Requester)

Requester is hereby notified that the filing date of the request for reexamination is 12/24/2013, the date the required fee of \$2,520 was received. (See CFR 1.510(d)).

A decision on the request for reexamination will be mailed within three months from the filing date of the request for reexamination. (See 37 CFR 1.515(a)).

Pursuant to 37 CFR 1.33(c), future correspondence in this reexamination proceeding will be with the latest attorney or agent of the record in the patent file.

The paragraphs checked below are part of this communication:

- 1. The party receiving the courtesy copy is the latest attorney or agent of record in the patent file.
- 2. The person named to receive the correspondence in this proceeding has not been made the latest attorney or agent of record in the patent file because:
 - A. Requester's claim of ownership of the patent is not verified by the record.
 - B. The request papers are not signed with a real or apparent binding signature.
 - C. The mere naming of a correspondence addressee does not result in that person being appointed as the latest attorney or agent of record in the patent file.
- 3. Addressee is the latest attorney or agent of record in the patent file.
- 4. Other _____

/rbell/

 Legal Instruments Examiner
 Central Reexamination Unit 571-272-7705; FAX No. 571-273-9900

REEXAM CONTROL NUMBER	FILING OR 371 (c) DATE	PATENT NUMBER
90/013,106	12/24/2013	5796183

25962
SLATER & MATSIL, L.L.P.
17950 PRESTON RD, SUITE 1000
DALLAS, TX 75252-5793

CONFIRMATION NO. 9188
REEXAM ASSIGNMENT NOTICE



Date Mailed: 01/15/2014

NOTICE OF ASSIGNMENT OF REEXAMINATION REQUEST

The above-identified request for reexamination has been assigned to Art Unit 3992. All future correspondence to the proceeding should be identified by the control number listed above and directed to the assigned Art Unit.

A copy of this Notice is being sent to the latest attorney or agent of record in the patent file or to all owners of record. (See 37 CFR 1.33(c)). If the addressee is not, or does not represent, the current owner, he or she is required to forward all communications regarding this proceeding to the current owner(s). An attorney or agent receiving this communication who does not represent the current owner(s) may wish to seek to withdraw pursuant to 37 CFR 1.36 in order to avoid receiving future communications. If the address of the current owner(s) is unknown, this communication should be returned within the request to withdraw pursuant to Section 1.36.

/rbell/

Legal Instruments Examiner
Central Reexamination Unit 571-272-7705; FAX No. 571-273-9900

Patent Assignment Abstract of Title

Total Assignments: 5

Application #: 08601268 Filing Dt: 01/31/1996 Patent #: 5796183 Issue Dt: 08/18/1998
PCT #: NONE Publication #: NONE Pub Dt:
Inventors: JOHN M. WASHELESKI, STEPHEN R. W. COOPER, BYRON HOURMAND
Title: CAPACITIVE RESPONSIVE ELECTRONIC SWITCHING CIRCUIT

Assignment: 1

Reel/Frame: 008254 / 0496 Received: 02/10/1997 Recorded: 01/31/1996 Mailed: 02/12/1997 Pages: 2

Conveyance: ASSIGNMENT OF ASSIGNORS INTEREST (SEE DOCUMENT FOR DETAILS).

Assignor: HOURMAND, BYRON

Exec Dt: 01/31/1996

Assignee: NARTRON CORPORATION
5000 NORTH U.S. 131
REED CITY, MICHIGAN 49677

Correspondent: PRICE, HENEVELD, COOPER,
DEWITT & LITTON
TERRY S. CALLAGHAN, ESQ.
P.O. BOX 2567
GRAND RAPIDS, MI 49501

Assignment: 2

Reel/Frame: 008443 / 0749 Received: 04/17/1997 Recorded: 02/04/1997 Mailed: 05/28/1997 Pages: 2

Conveyance: ASSIGNMENT OF ASSIGNORS INTEREST (SEE DOCUMENT FOR DETAILS).

Assignor: HOURMAND, BYRON

Exec Dt: 01/31/1996

Assignee: NARTRON CORPORATION
5000 NORTH US 131
REED CITY, MICHIGAN 49677

Correspondent: PRICE, HENEVELD, COOPER, ET AL
TERRY S. CALLAGHAN, ESQ.
P.O. BOX 2567
GRAND RAPIDS, MI 49501

Assignment: 3

Reel/Frame: 023679 / 0803 Received: 12/22/2009 Recorded: 12/22/2009 Mailed: 12/23/2009 Pages: 11

Conveyance: ASSIGNMENT OF ASSIGNORS INTEREST (SEE DOCUMENT FOR DETAILS).

Assignor: NARTRON CORPORATION

Exec Dt: 12/17/2009

Assignee: UUSI, LLC
5000 NORTH US HIGHWAY 131
REED CITY, MICHIGAN 49677

Correspondent: TAROLLI, SUNDHEIM, COVELL & TUMMINO LLP
1300 EAST NINTH STREET
SUITE 1700
CLEVELAND, OH 44114

Assignment: 4

Reel/Frame: 028804 / 0075 Received: 08/17/2012 Recorded: 08/17/2012 Mailed: 08/20/2012 Pages: 2

Conveyance: ASSIGNMENT OF ASSIGNORS INTEREST (SEE DOCUMENT FOR DETAILS).

Assignor: WASHELESKI, JOHN M.

Exec Dt: 04/14/2010

Assignee: NARTRON CORPORATION
5000 NORTH US-131
REED CITY, MICHIGAN 49677

Correspondent: SLATER & MATSIL, L.L.P.
17950 PRESTON RD.
SUITE 1000
DALLAS, TX 75252

Assignment: 5

Reel/Frame: 028804 / 0137 **Received:** 08/17/2012 **Recorded:** 08/17/2012 **Mailed:** 08/20/2012 **Pages:** 2

Conveyance: ASSIGNMENT OF ASSIGNORS INTEREST (SEE DOCUMENT FOR DETAILS).

Assignor: COOPER, STEPHEN R.W.

Exec Dt: 04/14/2010

Assignee: NARTRON CORPORATION
5000 NORTH US-131
REED CITY, MICHIGAN 49677

Correspondent: SLATER & MATSIL, L.L.P.
17950 PRESTON RD.
SUITE 1000
DALLAS, TX 75252

Search Results as of: 12/30/2013 02:39 PM

If you have any comments or questions concerning the data displayed, contact PRD / Assignments at 571-272-3350. v.2.2.4
Web interface last modified: Jul 8, 2013 v.2.2.4

Under the Paperwork Reduction Act of 1995, no persons are required to respond to a collection of information unless it displays a valid OMB control number.
(Also referred to as FORM PTO-1465)

REQUEST FOR EX PARTE REEXAMINATION TRANSMITTAL FORM

Address to:
Mail Stop Ex Parte Reexam
Commissioner for Patents
P.O. Box 1450
Alexandria, VA 22313-1450

Attorney Docket No.: **5796183RX2**

Date: **12/24/2013**

1. This is a request for *ex parte* reexamination pursuant to 37 CFR 1.510 of patent number 5,796,183 B1 issued August 18, 1998. The request is made by:
 patent owner. third party requester.
2. The name and address of the person requesting reexamination is:
UUSI, LLC
5000 North US Highway 131, 22nd Floor
Reed City, Michigan 49677
3. Requester claims small entity (37 CFR 1.27) or micro entity status (37 CFR 1.29) -- only a patent owner requester can claim micro entity status.
4. a. A check in the amount of \$ _____ is enclosed to cover the reexamination fee, 37 CFR 1.20(c)(1);
 b. The Director is hereby authorized to charge the fee as set forth in 37 CFR 1.20(c)(1) to Deposit Account No. 50-1065;
 c. Payment by credit card. Form PTO-2038 is attached; or
 d. Payment made via EFS-Web.
5. Any refund should be made by check or credit to Deposit Account No. 50-1065 37 CFR 1.26(c). If payment is made by credit card, refund must be to credit card account.
6. A copy of the patent to be reexamined having a double column format on one side of a separate paper is enclosed. 37 CFR 1.510(b)(4).
7. CD-ROM or CD-R in duplicate, Computer Program (Appendix) or large table
 Landscape Table on CD
8. Nucleotide and/or Amino Acid Sequence Submission
If applicable, items a. -- c. are required.
 - a. Computer Readable Form (CRF)
 - b. Specification Sequence Listing on:
 - i. CD-ROM (2 copies) or CD-R (2 copies); or
 - ii. paper
 - c. Statements verifying identity of above copies
9. A copy of any disclaimer, certificate of correction or reexamination certificate issued in the patent is included.
10. Reexamination of claim(s) 18 and 27 is requested.
11. A copy of every patent or printed publication relied upon is submitted herewith including a listing thereof on Form PTO/SB/08, PTO-1449, or equivalent.
12. An English language translation of all necessary and pertinent non-English language patents and/or printed publications is included.

[Page 1 of 2]

This collection of information is required by 37 CFR 1.510. The information is required to obtain or retain a benefit by the public which is to file (and by the USPTO to process) an application. Confidentiality is governed by 35 U.S.C. 122 and 37 CFR 1.11 and 1.14. This collection is estimated to take 18 minutes to complete, including gathering, preparing, and submitting the completed application form to the USPTO. Time will vary depending upon the individual case. Any comments on the amount of time you require to complete this form and/or suggestions for reducing this burden, should be sent to the Chief Information Officer, U.S. Patent and Trademark Office, U.S. Department of Commerce, P.O. Box 1450, Alexandria, VA 22313-1450. DO NOT SEND FEES OR COMPLETED FORMS TO THIS ADDRESS. SEND TO: **Mail Stop Ex Parte Reexam, Commissioner for Patents, P.O. Box 1450, Alexandria, VA 22313-1450.**

If you need assistance in completing the form, call 1-800-PTO-9199 and select option 2.

Under the Paperwork Reduction Act of 1995, no persons are required to respond to a collection of information unless it displays a valid OMB control number.

13. The attached detailed request includes at least the following items:
- a. A statement identifying each substantial new question of patentability based on prior patents and printed publications. 37 CFR 1.510(b)(1).
 - b. An identification of every claim for which reexamination is requested, and a detailed explanation of the pertinency and manner of applying the cited art to every claim for which reexamination is requested. 37 CFR 1.510(b)(2).

14. A proposed amendment is included (only where the patent owner is the requester). 37 CFR 1.510(e).

15. a. It is certified that a copy of this request (if filed by other than the patent owner) has been served in its entirety on the patent owner as provided in 37 CFR 1.33(c).

The name and address of the party served and the date of service are:

.....

Date of Service: _____; or

b. A duplicate copy is enclosed since service on patent owner was not possible. An explanation of the efforts made to serve patent owner is attached. See MPEP § 2220.

16. Correspondence Address: Direct all communication about the reexamination to:

The address associated with Customer Number:

25962

OR

Firm or Individual Name

Address

City	State	Zip
------	-------	-----

Country

Telephone	Email
-----------	-------

17. The patent is currently the subject of the following concurrent proceeding(s):

- a. Copending reissue Application No. _____
- b. Copending reexamination Control No. _____
- c. Copending Interference No. _____
- d. Copending litigation styled: _____

WARNING: Information on this form may become public. Credit card information should not be included on this form. Provide credit card information and authorization on PTO-2038.

/Brian A. Carlson/

Authorized Signature

December 24, 2013

Date

Brian A. Carlson

Typed/Printed Name

37,793

Registration No.

For Patent Owner Requester

For Third Party Requester

Privacy Act Statement

The **Privacy Act of 1974 (P.L. 93-579)** requires that you be given certain information in connection with your submission of the attached form related to a patent application or patent. Accordingly, pursuant to the requirements of the Act, please be advised that: (1) the general authority for the collection of this information is 35 U.S.C. 2(b)(2); (2) furnishing of the information solicited is voluntary; and (3) the principal purpose for which the information is used by the U.S. Patent and Trademark Office is to process and/or examine your submission related to a patent application or patent. If you do not furnish the requested information, the U.S. Patent and Trademark Office may not be able to process and/or examine your submission, which may result in termination of proceedings or abandonment of the application or expiration of the patent.

The information provided by you in this form will be subject to the following routine uses:

1. The information on this form will be treated confidentially to the extent allowed under the Freedom of Information Act (5 U.S.C. 552) and the Privacy Act (5 U.S.C. 552a). Records from this system of records may be disclosed to the Department of Justice to determine whether disclosure of these records is required by the Freedom of Information Act.
2. A record from this system of records may be disclosed, as a routine use, in the course of presenting evidence to a court, magistrate, or administrative tribunal, including disclosures to opposing counsel in the course of settlement negotiations.
3. A record in this system of records may be disclosed, as a routine use, to a Member of Congress submitting a request involving an individual, to whom the record pertains, when the individual has requested assistance from the Member with respect to the subject matter of the record.
4. A record in this system of records may be disclosed, as a routine use, to a contractor of the Agency having need for the information in order to perform a contract. Recipients of information shall be required to comply with the requirements of the Privacy Act of 1974, as amended, pursuant to 5 U.S.C. 552a(m).
5. A record related to an International Application filed under the Patent Cooperation Treaty in this system of records may be disclosed, as a routine use, to the International Bureau of the World Intellectual Property Organization, pursuant to the Patent Cooperation Treaty.
6. A record in this system of records may be disclosed, as a routine use, to another federal agency for purposes of National Security review (35 U.S.C. 181) and for review pursuant to the Atomic Energy Act (42 U.S.C. 218(c)).
7. A record from this system of records may be disclosed, as a routine use, to the Administrator, General Services, or his/her designee, during an inspection of records conducted by GSA as part of that agency's responsibility to recommend improvements in records management practices and programs, under authority of 44 U.S.C. 2904 and 2906. Such disclosure shall be made in accordance with the GSA regulations governing inspection of records for this purpose, and any other relevant (*i.e.*, GSA or Commerce) directive. Such disclosure shall not be used to make determinations about individuals.
8. A record from this system of records may be disclosed, as a routine use, to the public after either publication of the application pursuant to 35 U.S.C. 122(b) or issuance of a patent pursuant to 35 U.S.C. 151. Further, a record may be disclosed, subject to the limitations of 37 CFR 1.14, as a routine use, to the public if the record was filed in an application which became abandoned or in which the proceedings were terminated and which application is referenced by either a published application, an application open to public inspection or an issued patent.
9. A record from this system of records may be disclosed, as a routine use, to a Federal, State, or local law enforcement agency, if the USPTO becomes aware of a violation or potential violation of law or regulation.

IN THE UNITED STATES PATENT AND TRADEMARK OFFICE

U.S. Patent No.: 5,796,183 B1 § Docket No.: 5796183RX2
Issued: August 18, 1998 § Inventors: Hourmand et al.
Filed: January 31, 1996 § Patent Owner: UUSI, LLC
Control No. TBD § Examiner: TBD
For: Capacitive Responsive Electronic Switching Circuit

Mail Stop *Ex Parte* Reexam
Attn: Central Reexamination Unit
Commissioner for Patents
P.O. Box 1450
Alexandria, VA 22313-1450

REQUEST FOR *EX PARTE* REEXAMINATION UNDER 35 U.S.C. §§ 302-307

Dear Sir:

Patent Owner UUSI, LLC respectfully requests *Ex Parte* Reexamination, pursuant to the provisions of 35 U.S.C. §§ 302–307 (2002), of claims 18 and 27 of United States Patent No. 5,796,183 C1 (the “`183 Patent”). This patent is still enforceable.

As set forth below, some of the prior art references submitted herewith were not previously before the Office, and the combination of these references with previously considered references presents new, non-cumulative technological teachings not considered during the `183 Patent prosecution history including the first reexamination proceeding having control number 90/012,439.

I. OVERVIEW OF THE `183 PATENT AND ITS PROSECUTION HISTORY

Section I.A below provides an overview of the subject matter of the `183 Patent, while Section I.B provides an overview of its prosecution history.

A. The `183 Patent

The `183 Patent, a copy of which is provided as Exhibit A, issued on August 18, 1998 from an application filed on January 31, 1996. Ex Parte Reexamination Certification Number 5,796,183 C1 was issued for the `183 Patent on April 29, 2013. The `183 Patent generally relates to a capacitive responsive electronic switching circuit including an oscillator providing a periodic output signal, an input touch terminal defining an area for an operator to provide an input by proximity and touch, and a detector circuit coupled to the oscillator for receiving the periodic output signal from the oscillator, and coupled to the input touch terminal. *See, e.g.*, `183 Patent, Abstract.

The `183 Patent as reexamined contains 39 total claims, with claims 1, 9, 12, 16, 18, 20, 24, 27, and 37 being independent. Claims 18 and 27, which are the subject of this reexam request, require an oscillator, a microcontroller, a plurality of touch terminals, and a detector circuit.

An embodiment with a single touch terminal is shown in Figure 4, and an embodiment with multiple touch terminals is shown in Figure 11, both of which are reproduced below:

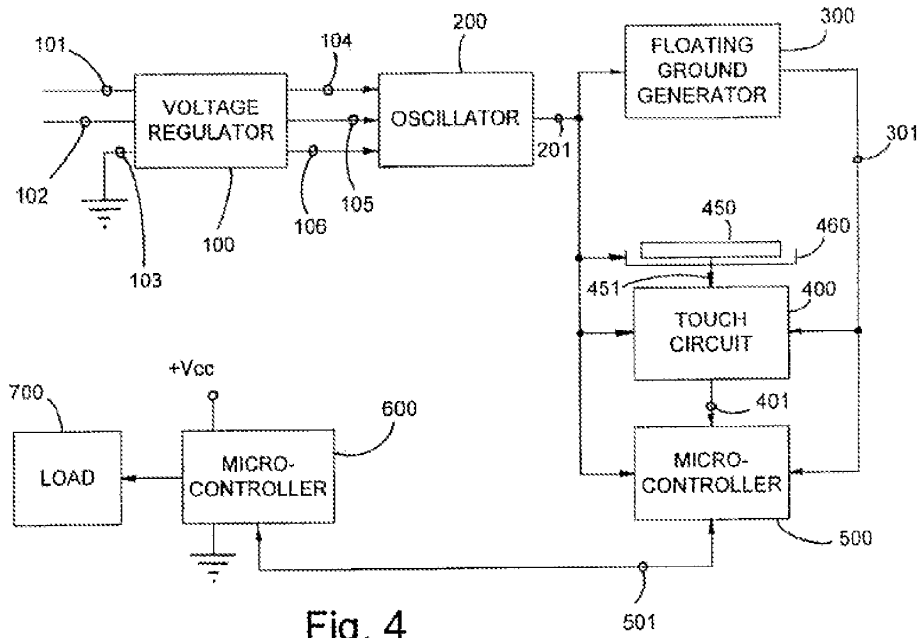

Fig. 4

Fig. 4 of the '183 Patent

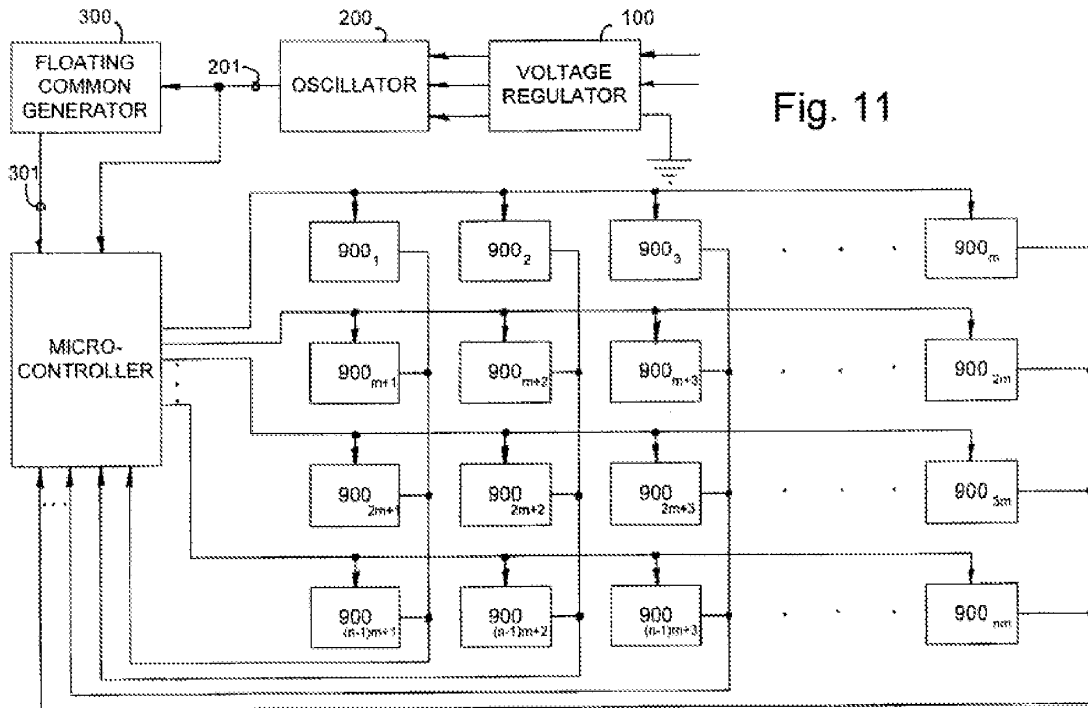

Fig. 11

Fig. 11 of the '183 Patent

The multiple touch pad circuit of Figure 11 is a variation of the embodiment shown in Figure 4, but with an array of touch circuits designated as 900₁ through 900_{nm}. *See, e.g., id.* at col. 18:34-43. The touch detection circuit offers improvements in detection sensitivity that allow close control of the degree of proximity (ideally very close proximity) that is required for actuation and to enable employment of a multiplicity of small sized touch terminals in a physically close array such as a keyboard. *See, e.g., id.* at col. 5:53-57.

Microcontroller 500 selects each row of the touch circuits 900₁ to 900_{nm} by providing the signal from oscillator 200 to selected rows of touch circuits. *See, e.g., id.* at col. 18:43-46. The values of the resistors and capacitors utilized in oscillator 200 may be varied to provide for different oscillator output frequencies. *See, e.g., id.* at col. 14:22-25. Although the preferred frequency is at or above 100 kHz, and more preferably at or above 800 kHz, it is conceivable that frequencies as low as 50 kHz could be used provided the frequency creates a difference in the impedance paths of adjacent pads that is sufficient enough to accurately distinguish between an intended touch and the touch of an adjacent pad. *See, e.g., id.* at col. 11:19-25.

Microcontroller 500 sequentially activates the touch circuit rows and associates the received inputs from the columns of the array with the activated touch circuit(s). *See, e.g., id.* at col. 18:46-49. The detector circuit is responsive to signals from the oscillator and the presence of an operator's body capacitance to ground coupled to the touch terminal when in proximity or touched by an operator to provide a control output signal. *See, e.g., id.* at Abstract. Another method for implementing capacitive touch switches relies on the change in capacitive coupling between a touch terminal and ground. *See, e.g., id.* at col. 3:44-46.

B. The Prosecution History of the `183 Patent

A copy of selected portions of the prosecution history of the `183 Patent is provided in Exhibit B.

The `183 Patent issued from U.S. Patent Application Serial No. 08/601,268 (“the `268 application”), filed on January 31, 1996, and naming Byron Hourmand as the sole inventor. A request for ex parte reexamination of the `183 Patent was filed on August 17, 2012 and assigned control number 90/012,439. Ex Parte Reexamination Certificate No. 5,796,183 C1 was thereafter issued on April 29, 2013.

The `268 application was filed with 20 total claims, of which four were independent. Claims 21-32 were added by subsequent amendment. A cross-reference between the originally issued claims and the application claims from which they issued is provided below for convenience.

Issued Claim	Appl. Claim	Issued Claim	Appl. Claim	Issued Claim	Appl. Claim	Issued Claim	Appl. Claim
1	1	9	5	17	16	25	25
2	2	10	6	18	18	26	26
3	3	11	7	19	19	27	27
4	4	12	12	20	20	28	28
5	8	13	13	21	21	29	29
6	9	14	14	22	22	30	30
7	10	15	17	23	23	31	31
8	11	16	15	24	24	32	32

In an Office Action dated April 22, 1997, the Examiner rejected application claims 6, 7 and 16 under 35 U.S.C. § 112, second paragraph, as being indefinite. *See* Ex. B, `183 Patent File History, Office Action, p. 2 (Apr. 22, 1997). Claims 6, 7 and 16 would be allowable if rewritten to overcome the section 112 rejection, and to include all of the limitations of the base claim and any intervening claims. *See id.* at p. 5.

Claims 1-4 and 12-14 were rejected under 35 U.S.C. § 102(b) as being anticipated by U.S. Patent No. 4,352,141 to Kent (“Kent”). *See id.* Claims 8-11, 18, and 19 were rejected under 35 § U.S.C. 103(a) as being unpatentable over Kent in view of U.S. Patent No. 5,087,825 to Ingraham (“Ingraham”), *see id.* at p. 3, and claims 8-11, 18 and 19 were rejected under 35 U.S.C. § 103(a) as being unpatentable over Kent in view of U.S. Patent No. 5,235,217 to Kirton (“Kirton”). *See id.* at p. 4. Lastly, claims 5 and 15 were objected to as being dependent upon a rejected base claim, but would be allowable if rewritten in independent form including all the limitations of the base claim and any intervening claims. *See id.* at p. 5.

In response, the Applicant filed an amendment on August 22, 1997, amending claims 1, 3, 5, 6, 12-18 and 20, and adding new claims 21-32. In particular, the Applicant amended independent claim 18 as follows:

18. (Amended) A capacitive responsive electronic switching circuit comprising:
an oscillator providing a periodic output signal having a predefined frequency;
a plurality of input touch terminals defining adjacent areas on a dielectric substrate for an operator to provide inputs by proximity and touch; and
a detector circuit coupled to said oscillator for receiving said periodic output signal from said oscillator, and coupled to said input touch terminals, said detector circuit being responsive to signals from said oscillator and the presence of an operator's body capacitance to ground coupled said touch terminals when proximal or touched by an operator to provide a control output signal,
wherein said predefined frequency of said oscillator is selected to decrease the impedance of said dielectric substrate relative to the impedance of any contaminate that may create an electrical on said dielectric substrate path between said adjacent areas, and wherein said detector circuit compares the sensed body capacitance to ground proximate an input touch terminal to a threshold level to prevent inadvertent generation of the control output signal.

Ex. B, `183 Patent File History, Amendment, p. 11 (Aug. 22, 1997). The Applicant argued that the Kent and Ingraham patents both fail to teach or suggest a capacitive responsive electronic switching circuit comprising a detector circuit that compares the sensed body capacitance proximate an input touch terminal to a threshold level in order to prevent inadvertent generation

of a control output signal. *See id.* at p. 19. The Applicant further argued that the Kirton patent, like the Kent and Ingraham patents, does not disclose a touch control circuit that is capable of discriminating between a full intentional touch of a touch terminal and an inadvertent touch of a portion of the surface of the touch terminal. *See id.*

With respect to new independent claim 27, the Applicant argued none of the cited references teaches or suggests a switching circuit for a control device that comprises at least first and second touch terminals and a detector circuit that generates a control output signal for actuation of the control device when an operator is proximal or touches the second touch terminal after the operator is proximal or touches the first touch terminal. *See id.* at pp. 20-21.

The Examiner issued a Notice of Allowance on October 27, 1997, allowing all of the pending claims. *See Ex. B, `183 Patent File History, Notice of Allowance, p. 2 (Oct. 27, 1997).* The Applicant then filed a section 312 amendment on November 3, 1997 to delete the word “said” after the word “when” in claim 27, line 11. *See Ex. B, `183 Patent File History, Amendment Under 37 C.F.R. § 1.312, p. 1 (Nov. 3, 1997).* The issue fee was paid on January 26, 1998, *see Ex. B, `183 Patent File History, Issue Fee Transmittal, p. 1 (Jan. 26, 1998),* and the `183 Patent subsequently issued on August 18, 1998.

The Applicant filed a certificate of correction on January 20, 1999, which was accepted by the patent office on May 11, 1999. In claim 18, the word “path” was inserted after the word “electrical” in column 27, line 44 of the `183 Patent, and the word “path” was deleted from column 27, line 45 of the `183 Patent. *See Ex. B, `183 Patent File History, Cert. of Correction, p. 3 (May 11, 1999).* In claim 27, the word “said” was deleted after the word “when.” *See id.*

The Patent Owner subsequently made several attempts to correct the inventorship of the patent, which resulted in the inventorship being changed to be Byron Hourmand, John M.

Washeleski and Stephen R. W. Cooper. *See* Ex. B, `183 Patent File History, Petition Decision (Aug. 25, 2011); *see also* Corrected Filing Receipt, p. 1 (Aug. 25, 2011); Certificate of Correction (Oct. 11, 2011).

On August 17, 2012, the Patent Owner filed a request for *ex parte* reexamination of claims 18 and 27 of the `183 Patent. *See* Ex. B, `183 Patent File History, Request for *Ex Parte* Reexamination under 35 U.S.C. §§ 302-307 (Aug. 17, 2012). The reexamination request was granted on September 20, 2012 and assigned control number 90/012,439. *See* Ex. B, `183 Patent File History, Order Granting / Denying Request for *Ex Parte* Reexamination (Sep. 20, 2012). Thereafter, the Patent Owner filed a Patent Owner Statement amending claims 18, 27, 28, and 32 and adding claims 33-39. *See* Ex. B, `183 Patent File History, Patent Owner Statement (Nov. 19, 2012).

In the Patent Owner Statement, claim 18 was amended to recite “a microcontroller using the periodic output signal from the oscillator, the microcontroller selectively providing signal output frequencies to a plurality of small sized input touch terminals of a keypad.” *See id.* at p. 2. Claim 27 was amended to recite “a microcontroller using the periodic output signal from the oscillator, the microcontroller selectively providing signal output frequencies to a closely spaced array of input touch terminals of a keypad, the input touch terminals comprising first and second input touch terminals.” *See id.* at p. 3. New independent claim 37 recited “a microcontroller using the periodic output signal from the oscillator, the microcontroller selectively providing signal output frequencies to a closely spaced array of input touch terminals of a keypad, the input touch terminals comprising first and second input touch terminals.” *See id.* at p. 5. The Patent Owner argued that the cited art, U.S. Patent No. 5,463,388 (“Boie”), does not teach or suggest these claim elements. *See id.* at pp. 7-9.

In the Statement of Reasons for Patentability and/or Confirmation, the Examiner agreed with the Patent Owner that Boie does not teach or suggest these elements. *See* Ex. B, `183 Patent File History, Notice of Intent to Issue Ex Parte Reexamination Certificate (Apr. 10, 2013), pp. 3-4. The Examiner stated, “Boie discloses driving the electrodes of electrode array 100 and guard plane 411 with a single RF signal. Boie does not teach or suggest providing signal output frequencies to these components.” *See id.* at p. 4.

The Ex Parte Reexamination Certificate thereafter issued on April 29, 2013. *See* Ex. A, Ex Parte Reexamination Certificate (Apr. 29, 2013).

II. SUBSTANTIAL NEW QUESTION (“SNQ”) OF PATENTABILITY

Section II.A below provides a list of the prior art references relied upon in the present request. Section II.B provides an overview of the prior art references. Section II.C provides a statement regarding an SNQ of patentability for claims 18 and 27 of the `183 Patent with respect to the new references.

A. Listing of Prior Art Patents and Publications

Reexamination of claims 18 and 27 of the `183 Patent is requested in view of the following references:

- Exhibit C Boie et al., U.S. Patent No. 5,463,388, filed on January 29, 1993 and issued on October 31, 1995 (“Boie”), which qualifies as 35 U.S.C. § 102(a)-type prior art.
- Exhibit D Gerpheide et al., U.S. Patent No. 5,565,658, filed on December 7, 1994 and issued on October 15, 1996 (“Gerpheide”), which qualifies as 35 U.S.C. § 102(e)-type prior art.
- Exhibit E Casio advertisement entitled “Now... The Invisible Casio Calculator Watch,” published in *Popular Science* by On the Run in 1984 (“Casio”), which qualifies as 35 U.S.C. § 102(b)-type prior art.

B. Overview of Prior Art Patents and Publications

As discussed in more detail below, combinations of Boie, Gerpheide, and Casio present new, non-cumulative technological teachings not considered during the `183 Patent prosecution history.

1. Boie

Boie generally relates to sensors for capacitively sensing the position or movement of an object, such as a finger, on a surface. *See, e.g.*, Boie, col. 1:6-8. A computer input device comprises a thin, insulating surface covering an array of electrodes arranged in a grid pattern and connected in columns and rows. *See, e.g., id.* at Abstract. Each column and row is connected to

circuitry for measuring the capacitance seen by each column and row. *See, e.g., id.* The position of an object with respect to the array is determined from the centroid of such capacitance values, which is calculated in a microcontroller. *See, e.g., id.* Figure 4, reproduced below, illustrates a block diagram of a two-dimensional capacitive position sensor.

FIG. 4

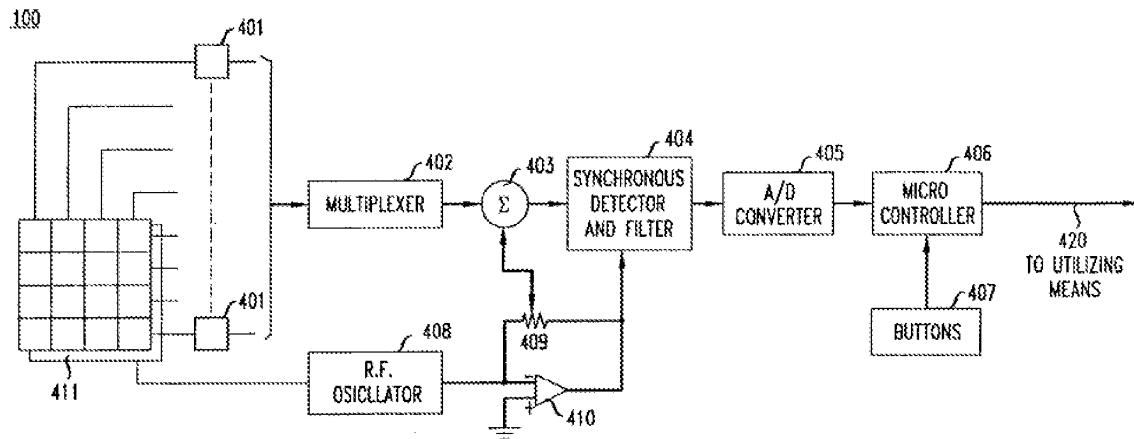

Fig. 4 of Boie

Each row and column of electrodes from array 100 is connected to an integrating amplifier and bootstrap circuit 401, each of which can be selected by multiplexer 402 under control of microcontroller 406. *See, e.g., id.* at col. 3:56-61. The selected output is forwarded to summing circuit 403, the output of which is converted by synchronous detector and filter 404 to a signal related to the capacitance of the row or column selected by multiplexer 402. *See, e.g., id.* at col. 3:62-67. RF oscillator 408 provides an RF signal of, for example, 100 kilohertz, to circuits 401, synchronous detector and filter 404 via inverter 410, and guard plane 411, which is a substantially continuous plane parallel to array 100 and associated connections, and serves to isolate array 100 from extraneous signals. *See, e.g., id.* at col. 3:67-col. 4:5.

To measure separate capacitance values for each electrode in array 100 instead of the collective capacitances of subdivided electrode elements connected in rows and columns, a circuit 401 is provided for each electrode in array 100 and multiplexer 402 is enlarged to accommodate the outputs from all circuits 401. *See, e.g., id.* at col. 4:14-21. The output of synchronous detector and filter 404 is converted to digital form by analog-to-digital converter 405 and forwarded to microcontroller 406 so that microcontroller 406 obtains a digital value representing the capacitance seen by any row or column of electrode elements (or electrode if measured separately) selected by multiplexer 402. *See, e.g., id.* at col. 4:22-28.

2. Gerpheide

Gerpheide generally relates to the rejection of electrical interference in capacitance-based touch detection apparatuses and methods. *See, e.g.,* Gerpheide, col. 1:12-14. In discussing the shortcomings of the prior art, Gerpheide states

[A] capacitance-based detection device may suffer from electrical background interference from its surroundings, which is coupled onto the sensing electrodes and interferes with position detection. These spurious signals cause troublesome interference with the detection of finger positioning. The device operator may even act as an antenna for electrical interference which may cause a false charge injection or depletion from the detecting electrodes. Accordingly, there is a need for a touch detection system which has the following characteristics: ... (3) electrical interference signals are rejected and eliminated from the detection system regardless of their frequency and without requiring possibly expensive nulling apparatus.

Id. at col. 2:37-57.

Figure 1 of Gerpheide (reproduced below) illustrates a capacitance variation finger (or other conductive body or non-body part) position sensing system 10 that includes an electrode array 12, a synchronous electrode capacitance measurement unit 14, a reference frequency generator 16, and a position locator 18. *See id.* at col. 3:52 – col. 4:26.

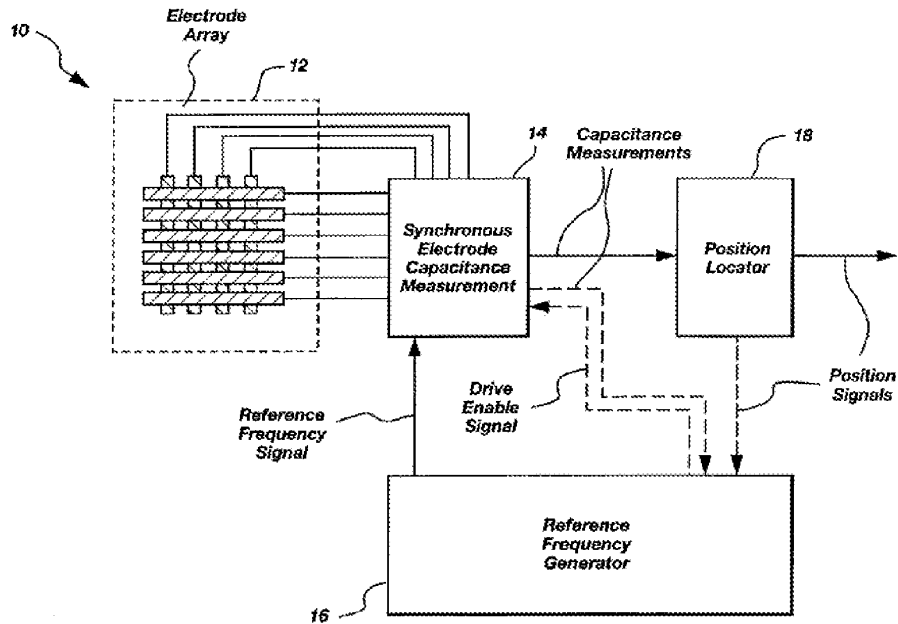
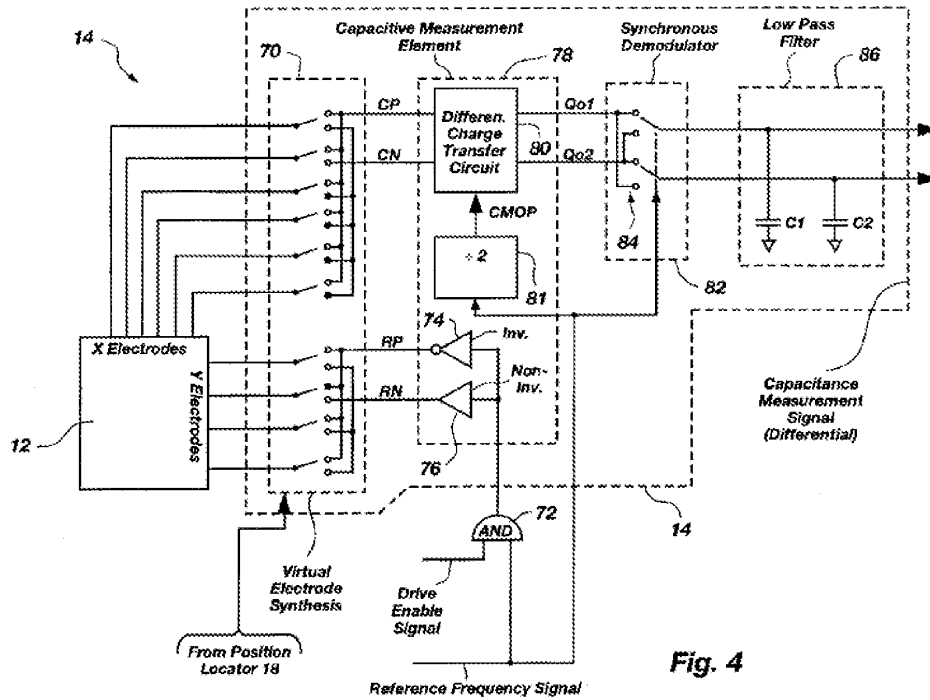

Fig. 1

Gerpheide, Figure 1

The electrode array 12 is described in relation to Figures 2a and 2b. *See generally id.* at col. 4:41 – col. 5:48; Figs. 2a and 2b. In Gerpheide, electrode array 12 consists of multiple X electrodes 20 and Y electrodes 22 and is preferably fabricated as a multi-layer printed circuit board 24. *See id.* at col. 4:41-48.

The synchronous electrode capacitance measurement unit 14 is connected to the electrode array 12 and one embodiment is further described with reference to Figure 4, reproduced below.



Gerpheide, Figure 4

According to Gerpheide,

The key elements of the synchronous electrode capacitance measurement unit 14 are (a) an element for producing a voltage change in the electrode array synchronously with a reference signal, (b) an element producing a signal indicative of the displacement charge thereby coupled between electrodes of the electrode array, (c) an element for demodulating this signal synchronously with the reference signal, and (d) an element for low pass filtering the demodulated signal.

See id. at col. 5:52-63; Fig. 4.

The reference frequency signal is preferably a digital logic signal from the reference frequency generator 16 (FIG. 1). The reference frequency signal is supplied to unit 14 via an AND gate 72 also having a "drive enable" input, supplied by the reference frequency generator 16 (FIG. 1). The AND gate output feeds through inverter 74 and noninverting buffer 76 to wires RP and RN respectively which are part of a capacitive measurement element 78.

See id. at col. 6:19-26; Fig. 4. The reference frequency generator 16 "observes position signals to evaluate the extent of interference at some reference frequency. In the event that substantial

interference is detected, the generator 16 selects a different frequency for further measurements. The generator 16 seeks to always select a reference frequency away from frequencies which have been found to result in measurement interference.” *See id.* at col. 8:22-30; Fig. 7. Reference frequency generator 16 is further illustrated with respect to Figure 7, reproduced below.

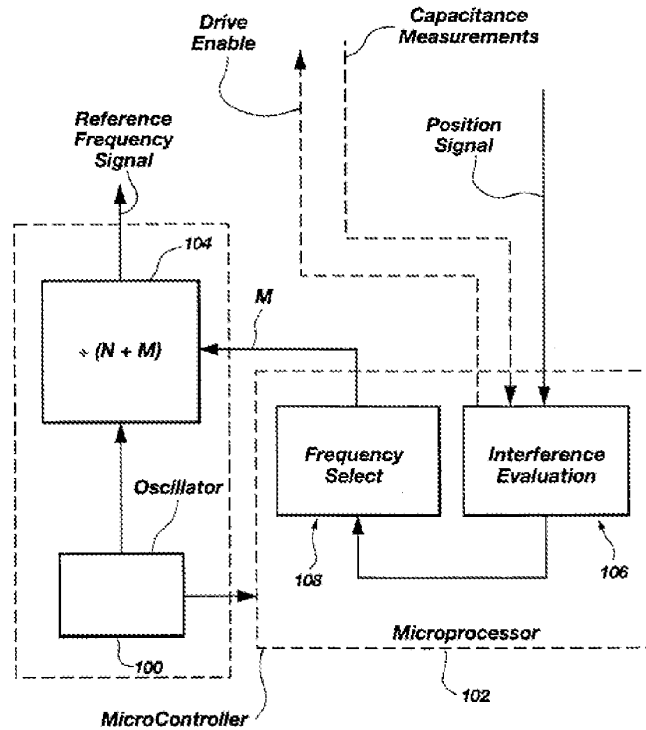

Fig. 7

Gerpheide, Figure 7

The generator 16 includes an oscillator 100. *See id.* at col. 8:31. The oscillator 100 drives a microcontroller 102 and a divide-by-(M+N) circuit 104. *See id.* at col. 8:31-33. Value N is a fixed constant, for example, approximately 50. *See id.* at col. 8:33-34. Microcontroller 102 specifies value M to be, for example, one of four values in the range 61 KHz to 80 KHz. *See id.* at col. 8:34-36. The microcontroller 102 performs the functions of interference evaluation 106 and frequency selection 108. *See id.* at col. 8:37-38.

3. Casio

Casio generally relates to a timepiece product employing electro-touch technology. *See, e.g.*, Casio, col. 1. The watch works by reading finger-strokes traced across its face. *See id.* The transparent touch panel construction includes a fiberglass panel having a transparent conductor film pattern (first layer) and a dielectric layer (second layer) overlying the fiberglass. *See id.* at col. 2; *see also* Figure in col. 2 (reproduced below).

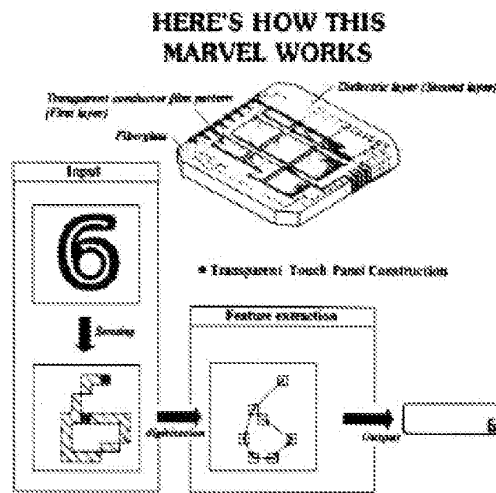

Id., col. 2.

The touch panel determines figure and math symbols outlined with finger-strokes traced across the face. *See id.* at col. 1. As shown in the figure above, the touch panel senses the input, and then digitizes it to extract features of the figure or math symbol. *See id.* at col. 2. The watch then outputs the corresponding figure or math symbol on the screen. *See id.* The advertisement states

This ... timepiece has a transparent crystal that reads finger-strokes you trace across its face. Each figure and math symbol you outline appears on the background digital display. Take your finger across twice (=) and the answer presents itself like magic.

No keys, no keyboards, no need to use stylus or pen. Even the broadest fingers will work. Add, subtract, multiply, divide – perform chain and mixed calculations

to eight places, plus decimal. There's even an indicator telling you which function is being performed.

See id. at col. 1.

C. Statement Pointing Out Each SNQ of Patentability

Boie was not cited during the original patent prosecution of the `183 Patent and was cited as an anticipatory reference in the first reexamination proceeding. The combination of Boie with Gerpheide and/or Casio presents new, non-cumulative technological teachings with respect to claims 18 and 27 of the `183 Patent.

1. Claim 18

During the first reexamination prosecution, the Patent Owner amended independent claim 18 to recite “a microcontroller using the periodic output signal from the oscillator, the microcontroller selectively providing signal output frequencies to a plurality of small sized input touch terminals of a keypad,” and argued that the cited art did not teach or suggest these limitations. After the Patent Owner made this amendment, the Examiner allowed claim 18 stating, “Boie discloses driving the electrodes of electrode array 100 and guard plane 411 with a single RF signal. Boie does not teach or suggest providing signal output frequencies to these components.” *See* Ex. B, `183 Patent File History, Notice of Intent to Issue Ex Parte Reexamination Certificate, p.4 (Apr. 10, 2013).

Gerpheide discloses,

[A reference frequency generator 16] observes position signals to evaluate the extent of interference at some reference frequency. In the event that substantial interference is detected, the generator 16 selects a different frequency for further measurements. The generator 16 seeks to always select a reference frequency away from frequencies which have been found to result in measurement interference, as described below. The generator 16 includes an oscillator 100 which is, for example, set at four MHz, driving a microcontroller 102 and a divide-by-(M+N) circuit 104. Value N is a fixed constant, approximately 50. Value M is specified by the microcontroller 102 to be, for example, one of four values in the range 61 KHz to 80 KHz as specified by the microcontroller 102.

The microcontroller 102 performs the functions of interference evaluation 106 and frequency selection 108.

Gerpheide, col. 8:22-38; Fig. 7. Thus, Gerpheide discloses selectively providing signal output frequencies.

It would have been obvious to one of ordinary skill in the art at the time of the invention to determine the single RF signal of Boie by evaluating the extent of interference at a given signal frequency and selecting a different frequency when substantial interference is detected as taught by Gerpheide. *See, e.g.*, Gerpheide, col. 8:22-38; Fig. 7.

The combination of Boie with Gerpheide thus presents new, non-cumulative technological teachings related to the elements of claim 18 added by amendment, and such teachings were not considered in the cited art during the '183 Patent prosecution history including the reexamination proceeding. If the original Examiners had known of each of these references, the Examiners likely would have considered them relevant, and likely would have cited them during the respective prosecution/proceeding. Boie in view of Gerpheide therefore raises an SNQ of patentability with respect to independent claim 18.

2. Claim 27

During the first reexamination prosecution, the Patent Owner amended independent claim 27 to recite “a microcontroller using the periodic output signal from the oscillator, the microcontroller selectively providing signal output frequencies to a closely spaced array of input touch terminals of a keypad, the input touch terminals comprising first and second input touch terminals,” and argued that the cited art did not teach or suggest these limitations. After the Patent Owner made this amendment, the Examiner allowed claim 27 stating, “Boie discloses driving the electrodes of electrode array 100 and guard plane 411 with a single RF signal. Boie does not teach or suggest providing signal output frequencies to these components.” *See Ex. B,*

183 Patent File History, Notice of Intent to Issue Ex Parte Reexamination Certificate (Apr. 10, 2013), p. 4.

Gerpheide discloses,

[A reference frequency generator 16] observes position signals to evaluate the extent of interference at some reference frequency. In the event that substantial interference is detected, the generator 16 selects a different frequency for further measurements. The generator 16 seeks to always select a reference frequency away from frequencies which have been found to result in measurement interference, as described below. The generator 16 includes an oscillator 100 which is, for example, set at four MHz, driving a microcontroller 102 and a divide-by-(M+N) circuit 104. Value N is a fixed constant, approximately 50. Value M is specified by the microcontroller 102 to be, for example, one of four values in the range 61 KHz to 80 KHz as specified by the microcontroller 102. The microcontroller 102 performs the functions of interference evaluation 106 and frequency selection 108.

Gerpheide, col. 8:22-38; Fig. 7. Thus, Gerpheide discloses selectively providing signal output frequencies.

It would have been obvious to one of ordinary skill in the art at the time of the invention to determine the single RF signal of Boie by evaluating the extent of interference at a given signal frequency and selecting a different frequency when substantial interference is detected as taught by Gerpheide. *See, e.g.*, Gerpheide, col. 8:22-38; Fig. 7.

Casio discloses first and second input touch terminals. *See, e.g.*, Casio, figure at col. 2, reproduced below. Specifically, the finger drawn 6 in the box in the lower left hand corner includes two black portions illustrating first and second input touch terminals.

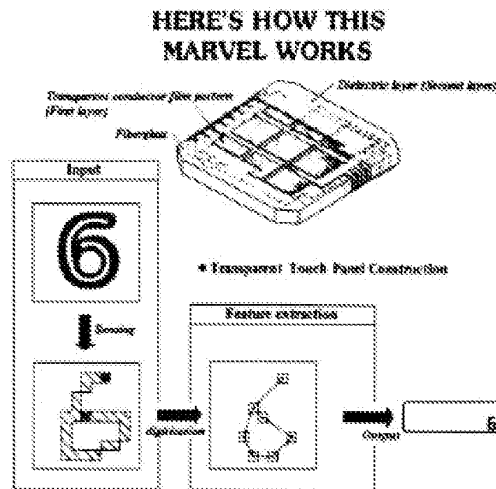

It would have been obvious to one of ordinary skill in the art at the time of the invention to modify the apparatus of Boie to sense first and second input touch terminals (electrodes) as taught by Casio in order to provide finger-stroke or finger-trace recognition capability. *See, e.g.*, Casio, col. 1, fourth paragraph and col. 3, third paragraph; figure (reproduced above).

The combination of Boie with Gerpheide and Casio thus presents new, non-cumulative technological teachings related to the elements of claim 27 added by amendment, and such teachings were not considered in the cited art during the '183 Patent prosecution history including the reexamination proceeding. If the original Examiners had known of each of these references, the Examiners likely would have considered them relevant, and likely would have cited them during the respective prosecution/proceeding. Boie in view of Gerpheide and Casio therefore raises an SNQ of patentability with respect to independent claim 27.

III. DETAILED EXPLANATION OF THE RELEVANCY AND MANNER OF APPLYING THE PRIOR ART REFERENCES TO EVERY CLAIM FOR WHICH REEXAMINATION IS REQUESTED

A detailed explanation pointing out the relevance and application of the prior art references to each of claims 18 and 27 is provided below. The charts below indicate what the Patent Owner believes are the portions of the cited art most relevant to the elements of the claims for which reexamination is requested. The Patent Owner, however, reserves the right to take positions asserting and submit arguments explaining why various claim elements are not disclosed or suggested by the cited art.

A. Claim 18

183 Patent Claim Language	Boie in view of Gerpheide
18. A capacitive responsive electronic switching circuit comprising:	“The capacitive sensor of the invention comprises a thin, insulating surface covering a plurality of electrodes. The position of an object, such as a finger or hand-held stylus, with respect to the electrodes, is determined from the centroid of capacitance values measured at the electrodes. . . . The x and y coordinates of the centroid are calculated in a microcontroller from the measured capacitances.” Boie, col. 1:61-col. 2:5, Fig. 4.
an oscillator providing a periodic output signal having a predefined frequency;	“RF oscillator 408 provides an RF signal, for example, 100 kilohertz, to circuits 401, synchronous detector and filter 404 via inverter 410, and guard plane 411.” Boie, col. 3:67-col. 4:2, Fig. 4.
a microcontroller using the periodic output signal from the oscillator, the microcontroller selectively providing signal output frequencies to a plurality of small sized input touch terminals of a keypad;	A reference frequency generator 16 “observes position signals to evaluate the extent of interference at some reference frequency. In the event that substantial interference is detected, the generator 16 selects a different frequency for further measurements. The generator 16 seeks to always select a reference frequency away from frequencies which have been found to result in measurement interference, as described below.

183 Patent Claim Language	Boie in view of Gerpheide
	<p>The generator 16 includes an oscillator 100 which is, for example, set at four MHz, driving a microcontroller 102 and a divide-by-(M+N) circuit 104. Value N is a fixed constant, approximately 50. Value M is specified by the microcontroller 102 to be, for example, one of four values in the range 61 KHz to 80 KHz as specified by the microcontroller 102. The microcontroller 102 performs the functions of interference evaluation 106 and frequency selection 108.” Gerpheide, col. 8:22-38; Fig. 7.</p> <p>“FIG. 2A illustrates the electrodes in a preferred electrode array 12, together with a coordinate axes defining X and Y directions. One embodiment includes sixteen X electrodes and twelve Y electrodes, but for clarity of illustration, only six X electrodes 20 and four Y electrodes 22 are shown. It is apparent to one skilled in the art how to extend the number of electrodes. The array is preferably fabricated as a multilayer printed circuit board 24. The electrodes are etched electrically conductive strips, connected to vias 26 which in turn connect them to other layers in the array. Illustratively, the array 12 is approximately 65 millimeters in the X direction and 49 millimeters in the Y direction. The X electrodes are approximately 0.7 millimeters wide on 3.3 millimeter centers. The Y electrodes are approximately three millimeters wide on 3.3 millimeter centers.” Gerpheide, col. 4:41-55; Fig. 2A.</p> <p>“FIG. 4 shows one embodiment of the synchronous electrode capacitance measurement unit 14 in more detail. The key elements of the synchronous electrode capacitance measurement unit 14 are (a) an element for producing a voltage change in the electrode array synchronously with a reference signal, (b) an element producing a signal indicative of the displacement charge thereby coupled between electrodes of the electrode array, (c) an element</p>

183 Patent Claim Language	Boie in view of Gerpheide
	<p>for demodulating this signal synchronously with the reference signal, and (d) an element for low pass filtering the demodulated signal. Unit 14 is coupled to the electrode array, preferably through a multiplexor or switches.” Gerpheide, col. 5:52-63; Fig. 4.</p> <p>“The reference frequency signal is preferably a digital logic signal from the reference frequency generator 16 (FIG. 1). The reference frequency signal is supplied to unit 14 via an AND gate 72 also having a "drive enable" input, supplied by the reference frequency generator 16 (FIG. 1). The AND gate output feeds through inverter 74 and noninverting buffer 76 to wires RP and RN respectively which are part of a capacitive measurement element 78.” Gerpheide, col. 6:19-26; Fig. 4.</p> <p>“The operational principle of the capacitive position sensor of the invention is shown in FIG. 1. Electrode array 100 is a square or rectangular array of electrodes 101 arranged in a grid pattern of rows and columns, as in an array of tiles. . . . The electrodes are covered with a thin layer of insulating material (not shown). . . . Histogram 110 shows the capacitances for electrodes 101 in array 100 with respect to finger 102.” Boie, col. 2:49-62, Fig. 1.</p> <p>“FIG. 2 shows four such subdivided electrodes in more detail at an intersection of two rows and two columns in array 100. As can be seen from FIG. 2, a horizontal element 201 and a vertical element 202 are situated at each intersection of a row and column.” Boie, col. 3:16-20, Fig. 2.</p> <p>“As will be clear to those skilled in the art, elements 201 and 202 can be fabricated in one plane of a multi-layer printed circuit board together with one set of interconnections, for example, the horizontal row connections 203. The vertical row connections 204 can then be fabricated in another plane of the circuit board</p>

183 Patent Claim Language	Boie in view of Gerpheide
	with appropriate via connections between the planes.” Boie, col. 3:30-36, Fig. 2.
<p>the plurality of small sized input touch terminals defining adjacent areas on a dielectric substrate for an operator to provide inputs by proximity and touch; and</p>	<p>“The operational principle of the capacitive position sensor of the invention is shown in FIG. 1. Electrode array 100 is a square or rectangular array of electrodes 101 arranged in a grid pattern of rows and columns, as in an array of tiles. . . . The electrodes are covered with a thin layer of insulating material (not shown). . . . Histogram 110 shows the capacitances for electrodes 101 in array 100 with respect to finger 102.” Boie, col. 2:49-62, Fig. 1.</p> <p>“FIG. 2 shows four such subdivided electrodes in more detail at an intersection of two rows and two columns in array 100. As can be seen from FIG. 2, a horizontal element 201 and a vertical element 202 are situated at each intersection of a row and column.” Boie, col. 3:16-20, Fig. 2.</p> <p>“As will be clear to those skilled in the art, elements 201 and 202 can be fabricated in one plane of a multi-layer printed circuit board together with one set of interconnections, for example, the horizontal row connections 203. The vertical row connections 204 can then be fabricated in another plane of the circuit board with appropriate via connections between the planes.” Boie, col. 3:30-36, Fig. 2.</p>
<p>a detector circuit coupled to said oscillator for receiving said periodic output signal from said oscillator, and coupled to said input touch terminals, said detector circuit being responsive to signals from said oscillator via said microcontroller and a presence of an operator's body capacitance to ground coupled to said touch terminals when proximal or touched by the operator to provide a control output signal,</p>	<p>“[E]ach row and column of electrodes from array 100 is connected to an integrating amplifier and bootstrap circuit 401, Each of the outputs from circuits 401 can be selected by multiplexer 402 under control of microcontroller 406. The selected output is then forwarded to summing circuit 403, where such output is combined with a signal from trimmer resistor 409. Synchronous detector and filter 404 convert the output from summing circuit 403 to a signal related to the capacitance of the row or column selected by multiplexer 402. RF oscillator 408 provides an RF signal, for</p>

183 Patent Claim Language	Boie in view of Gerpheide
	<p>example, 100 kilohertz, to circuits 401, synchronous detector and filter 404 via inverter 410, and guard plane 411.” Boie, col. 3:53-col. 4:2, Fig. 4.</p> <p>“The output of synchronous detector and filter 404 is converted to digital form by analog-to-digital converter 405 and forwarded to microcontroller 406. Thus, microcontroller 406 can obtain a digital value representing the capacitance seen by any row or column of electrode elements (or electrode if measured separately) selected by multiplexer 402. . . . Microcontroller 406 sends data to utilizing means, such as a personal computer (not shown) over lead 420.” Boie, col. 4:21-32, Fig. 4.</p>
<p>wherein said predefined frequency of said oscillator and said signal output frequencies are selected to decrease a first impedance of said dielectric substrate relative to a second impedance of any contaminate that may create an electrical path on said dielectric substrate between said adjacent areas defined by the plurality of small sized input touch terminals, and</p>	<p>“RF oscillator 408 provides an RF signal, for example, 100 kilohertz, to circuits 401, synchronous detector and filter 404 via inverter 410, and guard plane 411.” Boie, col. 3:67-col. 4:2, Fig. 4.</p> <p>“The effects of electrode-to-electrode capacitances, wiring capacitances and other extraneous capacitances are minimized by driving all electrodes and guard plane 411 in unison with the same RF signal from RF oscillator 408.” Boie, col. 4:58-61.</p> <p>“[A] capacitance-based detection device may suffer from electrical background interference from its surroundings, which is coupled onto the sensing electrodes and interferes with position detection. These spurious signals cause troublesome interference with the detection of finger positioning. The device operator may even act as an antenna for electrical interference which may cause a false charge injection or depletion from the detecting electrodes. Accordingly, there is a need for a touch detection system which has the following characteristics: . . . (3) electrical interference signals are rejected and eliminated from the</p>

183 Patent Claim Language	Boie in view of Gerpheide
	<p>detection system regardless of their frequency and without requiring possibly expensive nulling apparatus.” Gerpheide, col. 2:37-57.</p> <p>A reference frequency generator 16 “observes position signals to evaluate the extent of interference at some reference frequency. In the event that substantial interference is detected, the generator 16 selects a different frequency for further measurements. The generator 16 seeks to always select a reference frequency away from frequencies which have been found to result in measurement interference, as described below. The generator 16 includes an oscillator 100 which is, for example, set at four MHz, driving a microcontroller 102 and a divide-by-(M+N) circuit 104. Value N is a fixed constant, approximately 50. Value M is specified by the microcontroller 102 to be, for example, one of four values in the range 61 KHz to 80 KHz as specified by the microcontroller 102. The microcontroller 102 performs the functions of interference evaluation 106 and frequency selection 108.” Gerpheide, col. 8:22-38; Fig. 7.</p>
<p>wherein said detector circuit compares a sensed body capacitance change to ground proximate an input touch terminal to a threshold level to prevent inadvertent generation of the control output signal.</p>	<p>“Referring to FIG. 6, microcomputer 406 reads the initial capacitance values for all the elements in array 100 and stores such values (step 601). Such initial values should reflect the state of array 100 without a finger or other object being nearby, accordingly, it may be desirable to repeat step 601 a number of times and then to select the minimum capacitance values read as the initial values, thereby compensating for the effect of any objects moving close to array 100 during the initialization step. After initialization, all capacitance values are periodically read and the initial values subtracted to yield a remainder value for each element (step 602). If one or more of the remainders exceeds a preset threshold (step 603), indicating that an object is close to or touching array 100, then the x and y coordinates of the centroid of capacitance for such object can be calculated from such</p>

`183 Patent Claim Language	Boie in view of Gerpheide
	remainders (step 604). . . . To avoid spurious operation, it may be desirable to require that two or more measurements exceed the preset threshold. The threshold can be set to some percentage of the range of A/D converter 405, for example 10-15% of such range.” Boie, col. 5:10-48, Fig. 6.

B. Claim 27

`183 Patent Claim Language	Boie in view of Gerpheide and Casio
27. A capacitive responsive electronic switching circuit for a controlled keypad device comprising:	<p>“The capacitive sensor of the invention comprises a thin, insulating surface covering a plurality of electrodes. The position of an object, such as a finger or hand-held stylus, with respect to the electrodes, is determined from the centroid of capacitance values measured at the electrodes. . . . The x and y coordinates of the centroid are calculated in a microcontroller from the measured capacitances.” Boie, col. 1:61-col. 2:5, Fig. 4.</p> <p>“A computer input device for use as a computer mouse or keyboard comprises a thin, insulating surface covering an array of electrodes. . . . For applications in which the input device is used as a mouse, the microcontroller forwards position change information to the computer. For applications in which the input device is used as a keyboard, the microcomputer identifies a key from the position of the touching object and forwards such key identity to the computer.” Boie, Abstract.</p>
an oscillator providing a periodic output signal having a predefined frequency;	“RF oscillator 408 provides an RF signal, for example, 100 kilohertz, to circuits 401, synchronous detector and filter 404 via inverter 410, and guard plane 411.” Boie, col. 3:67-col. 4:2, Fig. 4.
a microcontroller using the periodic output signal from the oscillator, the	A reference frequency generator 16 “observes position signals to evaluate the extent of

183 Patent Claim Language	Boie in view of Gerpheide and Casio
<p>microcontroller selectively providing signal output frequencies to a closely spaced array of input touch terminals of a keypad, the input touch terminals comprising first and second input touch terminals;</p>	<p>interference at some reference frequency. In the event that substantial interference is detected, the generator 16 selects a different frequency for further measurements. The generator 16 seeks to always select a reference frequency away from frequencies which have been found to result in measurement interference, as described below. The generator 16 includes an oscillator 100 which is, for example, set at four MHz, driving a microcontroller 102 and a divide-by-(M+N) circuit 104. Value N is a fixed constant, approximately 50. Value M is specified by the microcontroller 102 to be, for example, one of four values in the range 61 KHz to 80 KHz as specified by the microcontroller 102. The microcontroller 102 performs the functions of interference evaluation 106 and frequency selection 108.” Gerpheide, col. 8:22-38; Fig. 7.</p> <p>“FIG. 2A illustrates the electrodes in a preferred electrode array 12, together with a coordinate axes defining X and Y directions. One embodiment includes sixteen X electrodes and twelve Y electrodes, but for clarity of illustration, only six X electrodes 20 and four Y electrodes 22 are shown. It is apparent to one skilled in the art how to extend the number of electrodes. The array is preferably fabricated as a multilayer printed circuit board 24. The electrodes are etched electrically conductive strips, connected to vias 26 which in turn connect them to other layers in the array. Illustratively, the array 12 is approximately 65 millimeters in the X direction and 49 millimeters in the Y direction. The X electrodes are approximately 0.7 millimeters wide on 3.3 millimeter centers. The Y electrodes are approximately three millimeters wide on 3.3 millimeter centers.” Gerpheide, col. 4:41-55; Fig. 2A.</p> <p>“FIG. 4 shows one embodiment of the synchronous electrode capacitance measurement unit 14 in more detail. The key elements of the</p>

183 Patent Claim Language	Boie in view of Gerpheide and Casio
	<p>synchronous electrode capacitance measurement unit 14 are (a) an element for producing a voltage change in the electrode array synchronously with a reference signal, (b) an element producing a signal indicative of the displacement charge thereby coupled between electrodes of the electrode array, (c) an element for demodulating this signal synchronously with the reference signal, and (d) an element for low pass filtering the demodulated signal. Unit 14 is coupled to the electrode array, preferably through a multiplexor or switches.” Gerpheide, col. 5:52-63; Fig. 4.</p> <p>“The reference frequency signal is preferably a digital logic signal from the reference frequency generator 16 (FIG. 1). The reference frequency signal is supplied to unit 14 via an AND gate 72 also having a "drive enable" input, supplied by the reference frequency generator 16 (FIG. 1). The AND gate output feeds through inverter 74 and noninverting buffer 76 to wires RP and RN respectively which are part of a capacitive measurement element 78.” Gerpheide, col. 6:19-26; Fig. 4.</p> <p>“The operational principle of the capacitive position sensor of the invention is shown in FIG. 1. Electrode array 100 is a square or rectangular array of electrodes 101 arranged in a grid pattern of rows and columns, as in an array of tiles. . . . The electrodes are covered with a thin layer of insulating material (not shown). . . . Histogram 110 shows the capacitances for electrodes 101 in array 100 with respect to finger 102.” Boie, col. 2:49-62, Fig. 1.</p> <p>“FIG. 2 shows four such subdivided electrodes in more detail at an intersection of two rows and two columns in array 100. As can be seen from FIG. 2, a horizontal element 201 and a vertical element 202 are situated at each intersection of a row and column.” Boie, col. 3:16-20, Fig. 2.</p>

183 Patent Claim Language	Boie in view of Gerpheide and Casio
	<p>“As will be clear to those skilled in the art, elements 201 and 202 can be fabricated in one plane of a multi-layer printed circuit board together with one set of interconnections, for example, the horizontal row connections 203. The vertical row connections 204 can then be fabricated in another plane of the circuit board with appropriate via connections between the planes.” Boie, col. 3:30-36, Fig. 2.</p>
<p>the first and second input touch terminals defining areas for an operator to provide an input by proximity and touch; and</p>	<p>“The operational principle of the capacitive position sensor of the invention is shown in FIG. 1. Electrode array 100 is a square or rectangular array of electrodes 101 arranged in a grid pattern of rows and columns, as in an array of tiles. . . . The electrodes are covered with a thin layer of insulating material (not shown). . . . Histogram 110 shows the capacitances for electrodes 101 in array 100 with respect to finger 102.” Boie, col. 2:49-62, Fig. 1.</p> <p>“FIG. 2 shows four such subdivided electrodes in more detail at an intersection of two rows and two columns in array 100. As can be seen from FIG. 2, a horizontal element 201 and a vertical element 202 are situated at each intersection of a row and column.” Boie, col. 3:16-20, Fig. 2.</p> <p>“As will be clear to those skilled in the art, elements 201 and 202 can be fabricated in one plane of a multi-layer printed circuit board together with one set of interconnections, for example, the horizontal row connections 203. The vertical row connections 204 can then be fabricated in another plane of the circuit board with appropriate via connections between the planes.” Boie, col. 3:30-36, Fig. 2.</p>

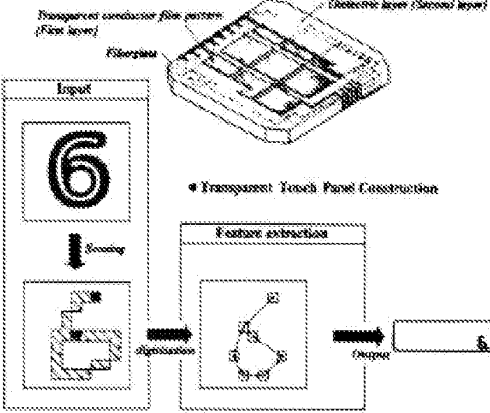
183 Patent Claim Language	Boie in view of Gerpheide and Casio
	<p style="text-align: center;">HERE'S HOW THIS MARVEL WORKS</p>  <p style="text-align: center;">Casio, col. 2.</p>
<p>a detector circuit coupled to said oscillator for receiving said periodic output signal from said oscillator, and coupled to said first and second touch terminals, said detector circuit being responsive to signals from said oscillator via said microcontroller and a presence of an operator's body capacitance to ground coupled to said first and second touch terminals when proximal or touched by the operator to provide a control output signal for actuation of the controlled keypad device,</p>	<p>“[E]ach row and column of electrodes from array 100 is connected to an integrating amplifier and bootstrap circuit 401, Each of the outputs from circuits 401 can be selected by multiplexer 402 under control of microcontroller 406. The selected output is then forwarded to summing circuit 403, where such output is combined with a signal from trimmer resistor 409. Synchronous detector and filter 404 convert the output from summing circuit 403 to a signal related to the capacitance of the row or column selected by multiplexer 402. RF oscillator 408 provides an RF signal, for example, 100 kilohertz, to circuits 401, synchronous detector and filter 404 via inverter 410, and guard plane 411.” Boie, col. 3:53-col. 4:2, Fig. 4.</p> <p>“The output of synchronous detector and filter 404 is converted to digital form by analog-to-digital converter 405 and forwarded to microcontroller 406. Thus, microcontroller 406 can obtain a digital value representing the capacitance seen by any row or column of electrode elements (or electrode if measured separately) selected by multiplexer 402. . . . Microcontroller 406 sends data to utilizing means, such as a personal computer (not shown)</p>

183 Patent Claim Language	Boie in view of Gerpheide and Casio
	<p>over lead 420.” Boie, col. 4:21-32, Fig. 4.</p> <p>“A computer input device for use as a computer mouse or keyboard comprises a thin, insulating surface covering an array of electrodes. . . . For applications in which the input device is used as a mouse, the microcontroller forwards position change information to the computer. For applications in which the input device is used as a keyboard, the microcomputer identifies a key from the position of the touching object and forwards such key identity to the computer.” Boie, Abstract.</p> <div data-bbox="787 798 1282 1281" data-label="Diagram"> <p style="text-align: center;">HERE'S HOW THIS MARVEL WORKS</p> </div> <p>Casio, col. 2.</p>
<p>said detector circuit being configured to generate said control output signal when the operator is proximal or touches said second touch terminal after the operator is proximal or touches said first touch terminal.</p>	<p>“In using the position sensor of the invention as a computer mouse or trackball to control a cursor, movement of the mouse or trackball is emulated by touching array 100 with finger 102, or some other object, and stroking finger 102 over array 100 to move the cursor. Changes in position of the finger with respect to array 100 are reflected in corresponding changes in position of the cursor. Thus, for such an application, microcontroller 406 sends data over lead 420 relating to changes in position. FIG. 6 is a flow chart of the operation of microcontroller 406 in such an application.” Boie, col. 4:67-col. 5:9, Fig. 6.</p>

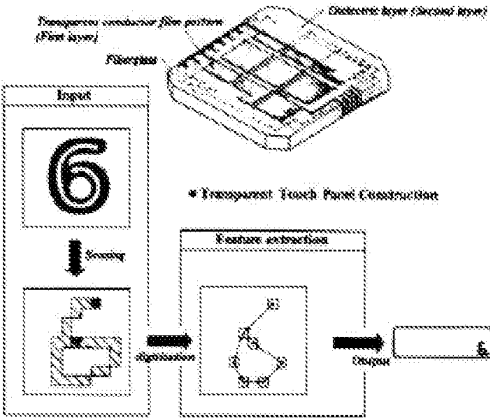
183 Patent Claim Language	Boie in view of Gerpheide and Casio
	<p style="text-align: center;">HERE'S HOW THIS MARVEL WORKS</p>  <p style="text-align: center;">Casio, col. 2.</p>

IV. CONCLUSION

A substantial new question of patentability is raised based on the newly cited prior art combinations, and therefore a reexamination of claims 18 and 27 is warranted. Again, the Patent Owner reserves the right to take positions asserting and to submit arguments explaining why various claim elements are not disclosed or suggested by the cited art.

If the Office should have any questions, please contact the undersigned attorney. The Commissioner is hereby authorized to charge any fees due in connection with this filing, or credit any overpayment, to Deposit Account No. 50-1065.

Respectfully submitted,

December 24, 2013
Date

/Brian A. Carlson/
Brian A. Carlson
Reg. No. 37,793

Slater & Matsil, L.L.P.
17950 Preston Rd.
Suite 1000
Dallas, TX 75252
972-732-1001
972-732-9218 (fax)

EXHIBIT A

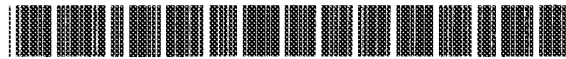

US005796183A

United States Patent [19] Hourmand

[11] Patent Number: **5,796,183**
[45] Date of Patent: **Aug. 18, 1998**

[54] CAPACITIVE RESPONSIVE ELECTRONIC SWITCHING CIRCUIT

[75] Inventor: Byron Hourmand, Hersey, Mich.

[73] Assignee: Nartron Corporation, Reed City, Mich.

[21] Appl. No.: 601,268

[22] Filed: Jan. 31, 1996

[51] Int. Cl.⁶ H01H 35/00

[52] U.S. Cl. 307/116; 361/181; 307/125; 307/139

[58] Field of Search 307/112, 113, 307/116, 125, 139, 140, 157; 361/181

[56] References Cited

U.S. PATENT DOCUMENTS

- 3,549,909 12/1970 Adelson et al.
- 3,641,410 2/1972 Vogelsberg
- 3,651,391 3/1972 Vogelsberg
- 3,666,988 5/1972 Bellis
- 3,798,370 3/1974 Hurst
- 3,879,618 4/1975 Larson 307/116
- 3,899,713 8/1975 Barkan et al.
- 3,911,215 10/1975 Hurst et al.
- 3,919,596 11/1975 Bellis
- 3,965,465 6/1976 Alexander
- 3,984,757 10/1976 Gott et al.
- 4,016,453 4/1977 Moennig
- 4,031,408 6/1977 Holz
- 4,071,689 1/1978 Talmage et al.
- 4,101,805 7/1978 Stone
- 4,119,864 10/1978 Petrizio
- 4,152,629 5/1979 Raupp
- 4,159,473 6/1979 Senk
- 4,210,822 7/1980 Wern
- 4,211,959 7/1980 Deavenport et al.
- 4,213,061 7/1980 Conner
- 4,220,815 9/1980 Gibson et al.
- 4,237,421 12/1980 Waldron
- 4,246,533 1/1981 Chiang
- 4,257,117 3/1981 Besson
- 4,264,831 4/1981 Wern
- 4,289,972 9/1981 Wern
- 4,289,980 9/1981 McLaughlin

- 4,308,443 12/1981 Tucker et al.
- 4,323,829 4/1982 Witney et al.
- 4,352,141 9/1982 Kent 363/181
- 4,360,737 11/1982 Leopold
- 4,374,381 2/1983 Ng et al.
- 4,476,463 10/1984 Ng et al.
- 4,503,294 3/1985 Matsumaru 200/5 A
- 4,731,548 3/1988 Ingraham
- 4,758,735 7/1988 Ingraham
- 4,831,279 5/1989 Ingraham
- 4,910,504 3/1990 Eriksson
- 4,939,382 7/1990 Grudis 4/623
- 4,942,631 7/1990 Rosa
- 5,012,124 4/1991 Holloway
- 5,066,898 11/1991 Miller et al.
- 5,087,825 2/1992 Ingraham
- 5,208,516 5/1993 Saidian
- 5,233,231 8/1993 Wieth et al.
- 5,235,217 8/1993 Kirton 307/326
- 5,386,219 1/1995 Greanias et al.
- 5,453,644 9/1995 Yap et al.
- 5,572,205 11/1996 Caldwell et al. 341/33

Primary Examiner—William M. Shoop, Jr.
Assistant Examiner—Jonathan Kaplan
Attorney, Agent, or Firm—Price, Heneveld, Cooper, DeWitt & Litton

[57] ABSTRACT

A capacitive responsive electronic switching circuit comprises an oscillator providing a periodic output signal having a frequency of 50 kHz or greater, an input touch terminal defining an area for an operator provide an input by proximity and touch, and a detector circuit coupled to the oscillator for receiving the periodic output signal from the oscillator, and coupled to the input touch terminal. The detector circuit being responsive to signals from the oscillator and the presence of an operator's body capacitance to ground coupled to the touch terminal when in proximity or touched by an operator to provide a control output signal. Preferably, the oscillator provides a periodic output signal having a frequency of 800 kHz or greater. An array of touch terminals may be provided in close proximity due to the reduction in crosstalk that may result from contaminants by utilizing an oscillator outputting a signal having a frequency of 50 kHz or greater.

32 Claims, 13 Drawing Sheets

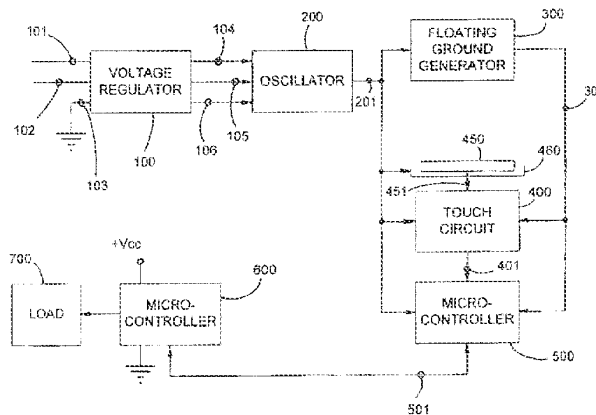

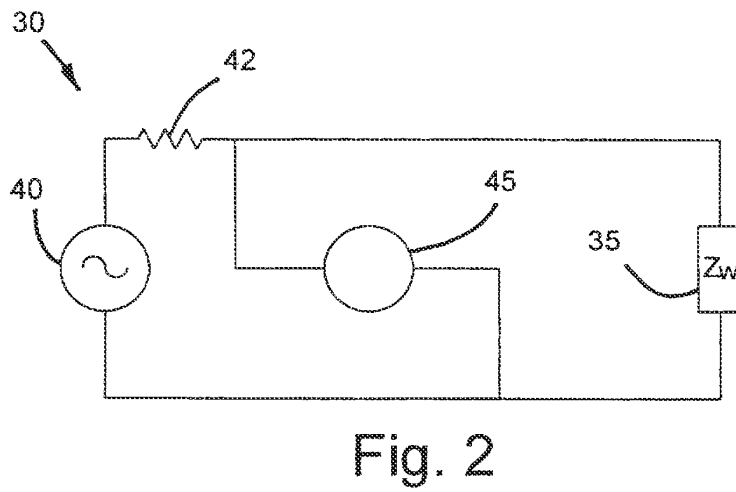
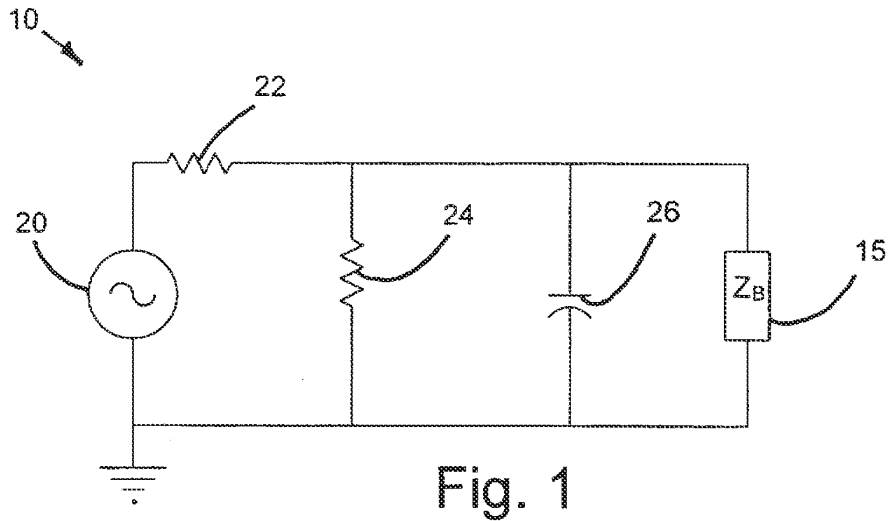

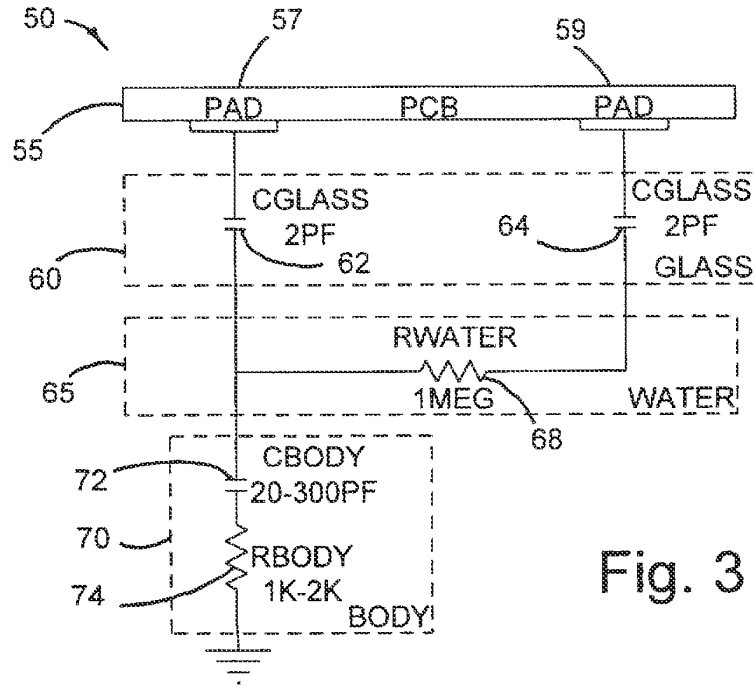

Fig. 3

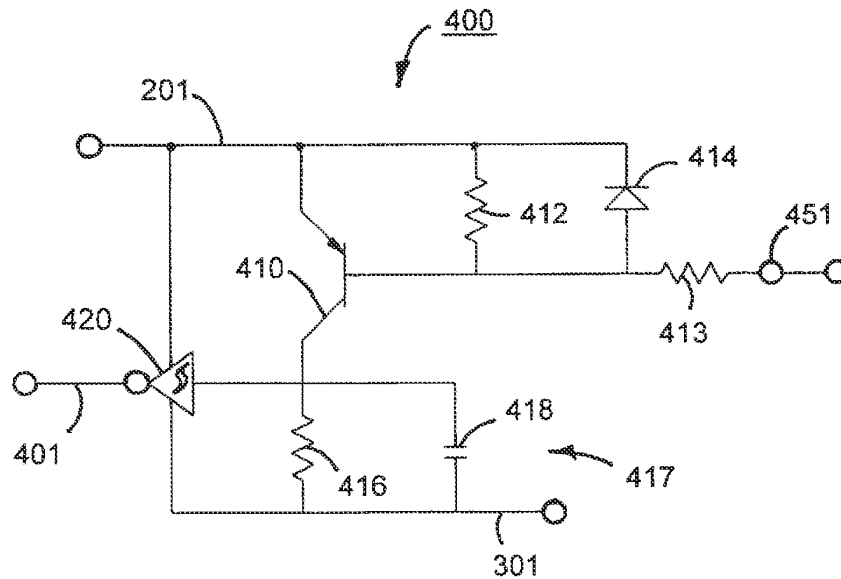

Fig. 8

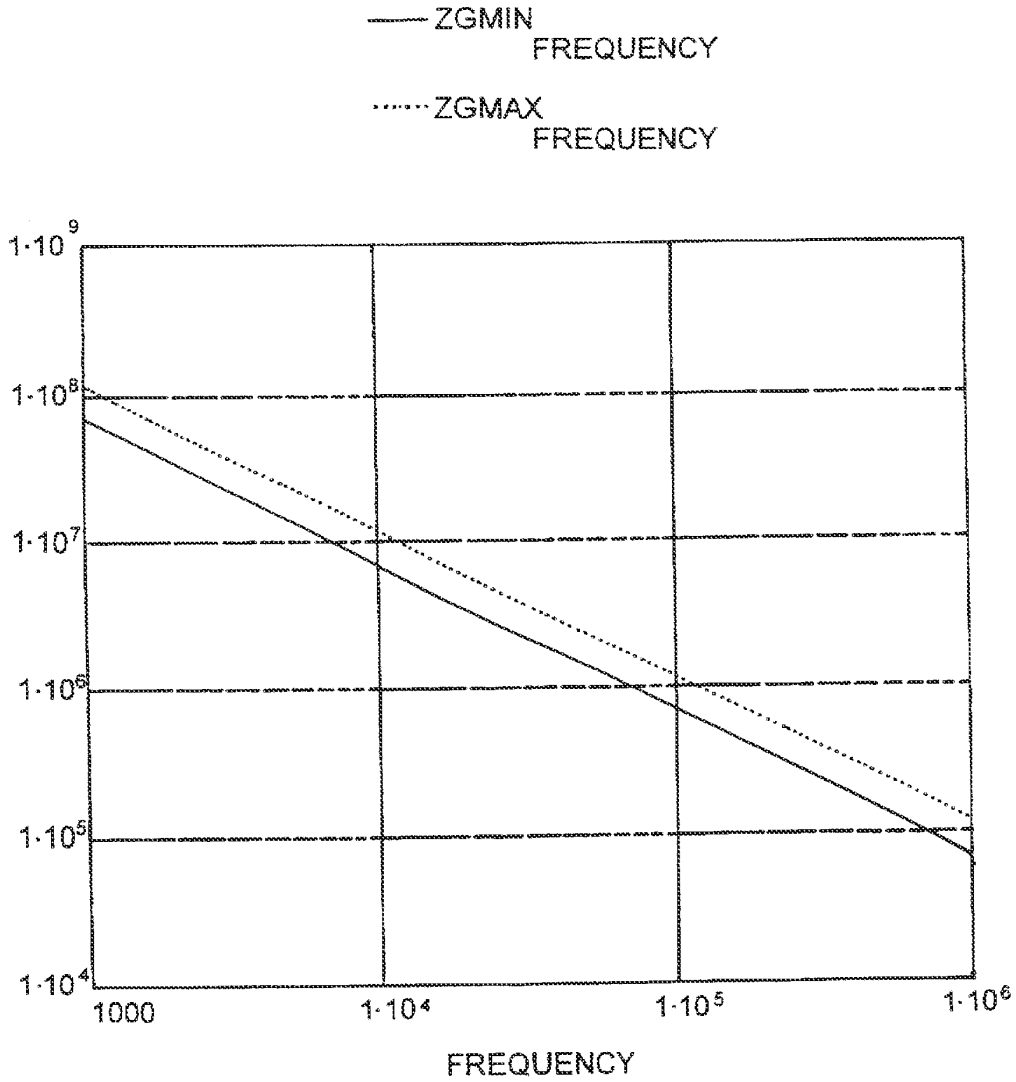

Fig. 3A

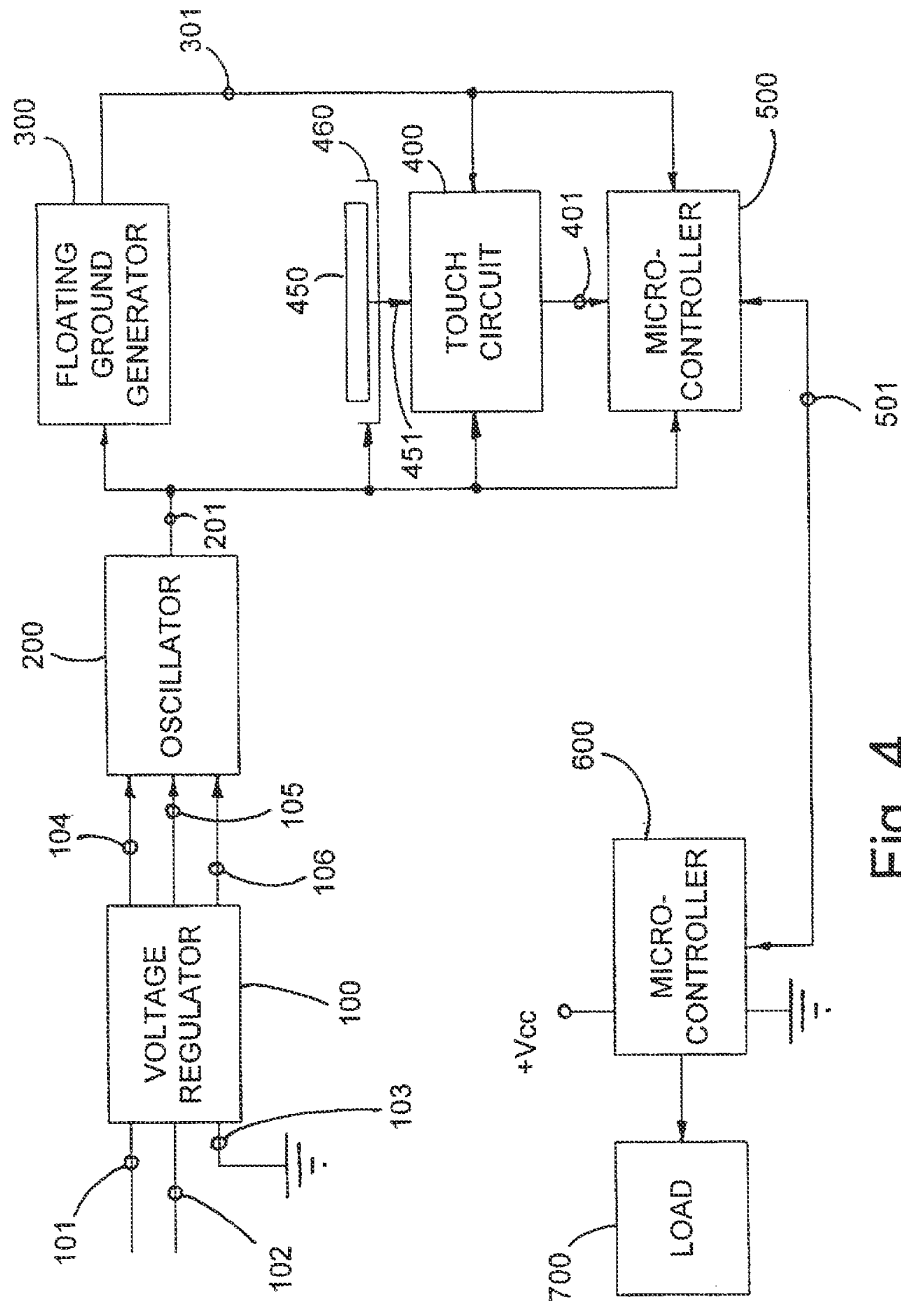
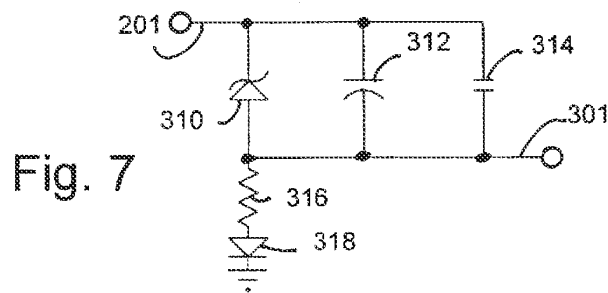
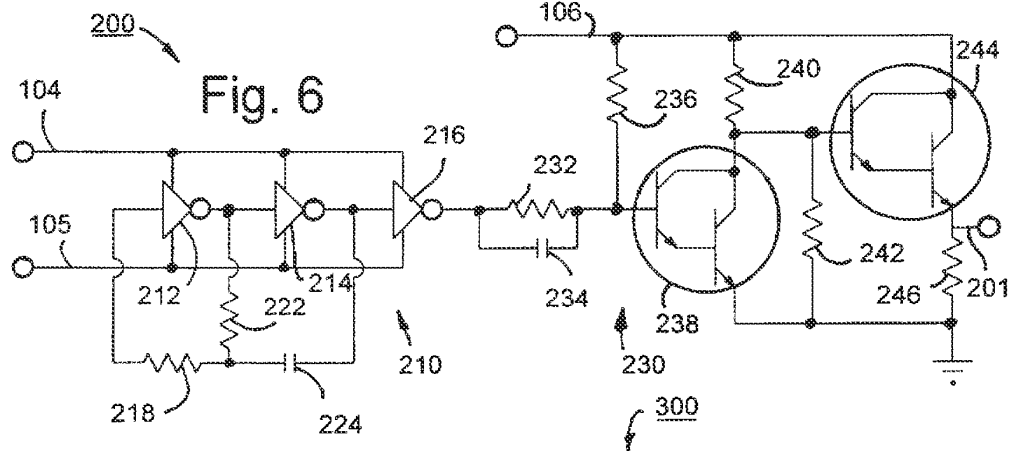
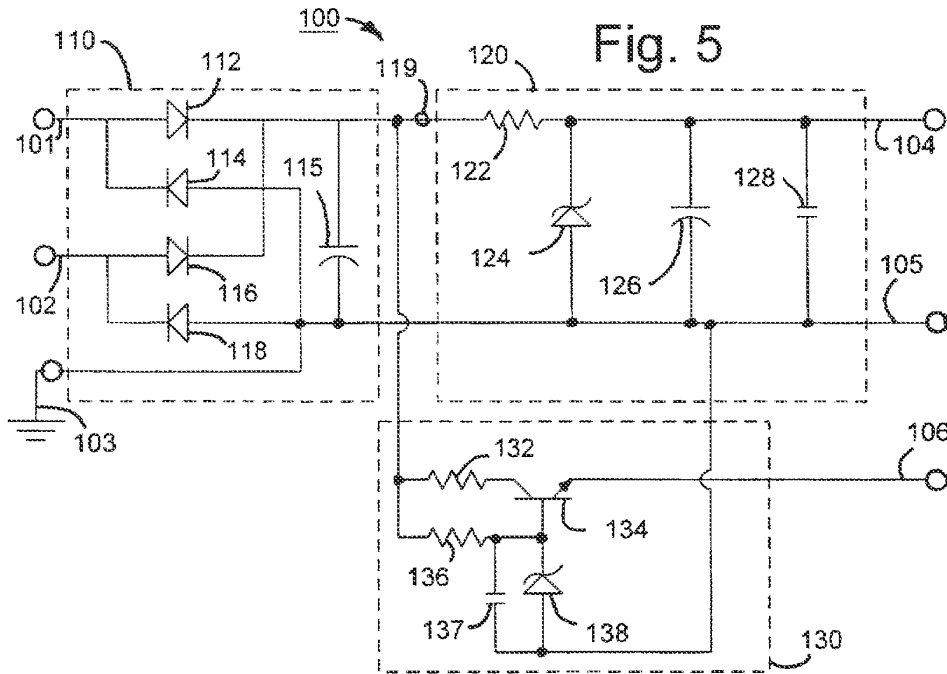

Fig. 4



S/N VS. BODY CAPACITANCE
TEMPERATURE = 105°C

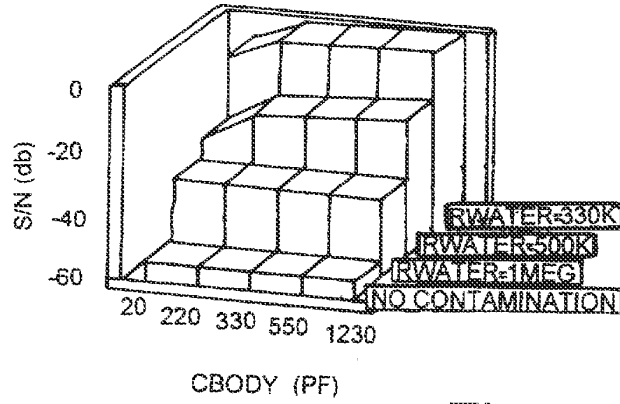

Fig. 9

S/N VS. BODY CAPACITANCE
TEMPERATURE = 25°C

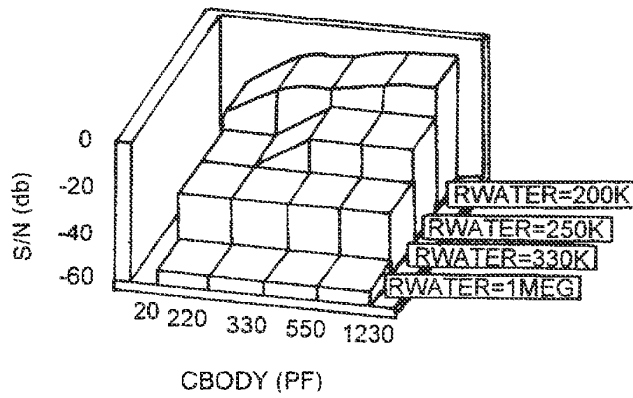

Fig. 10

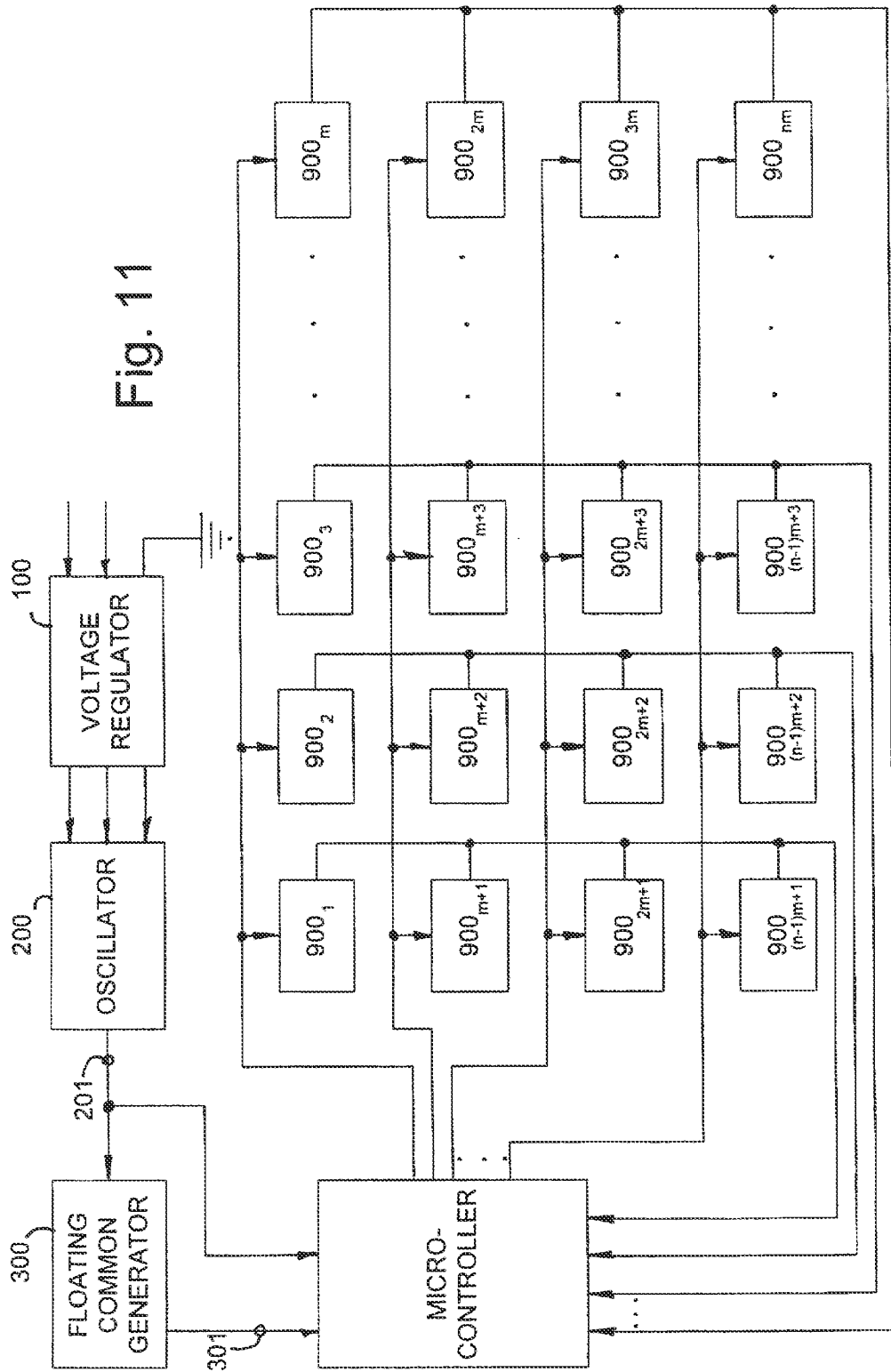

Fig. 11

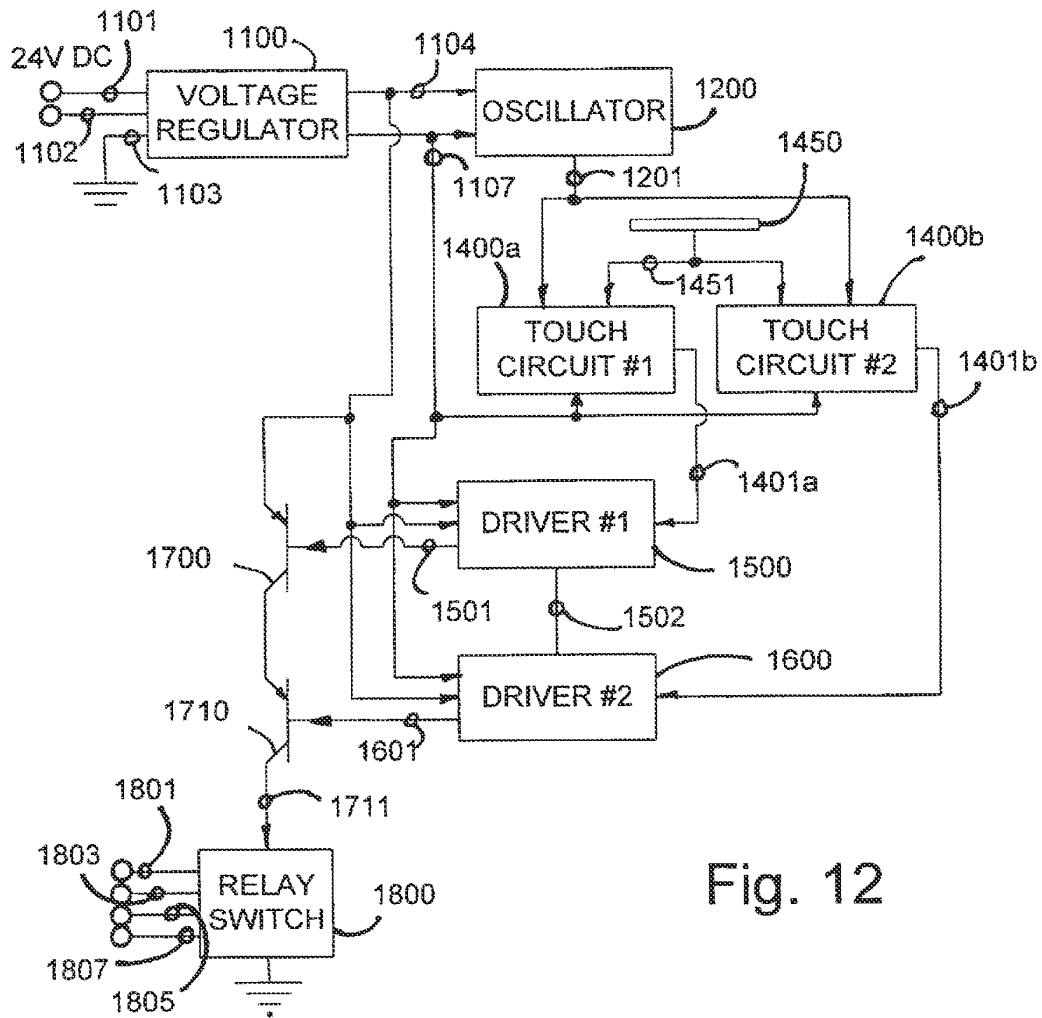

Fig. 12

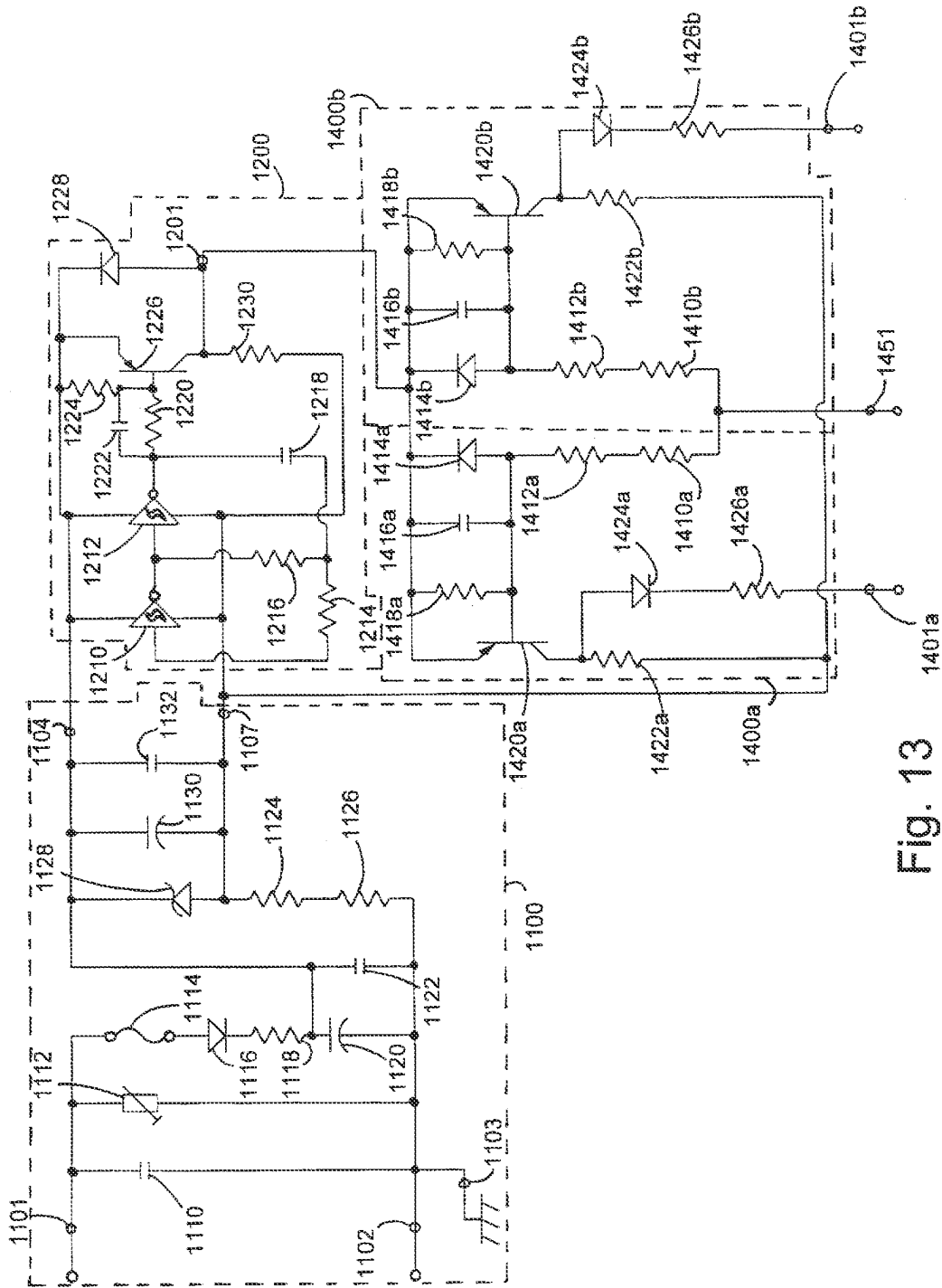

Fig. 13

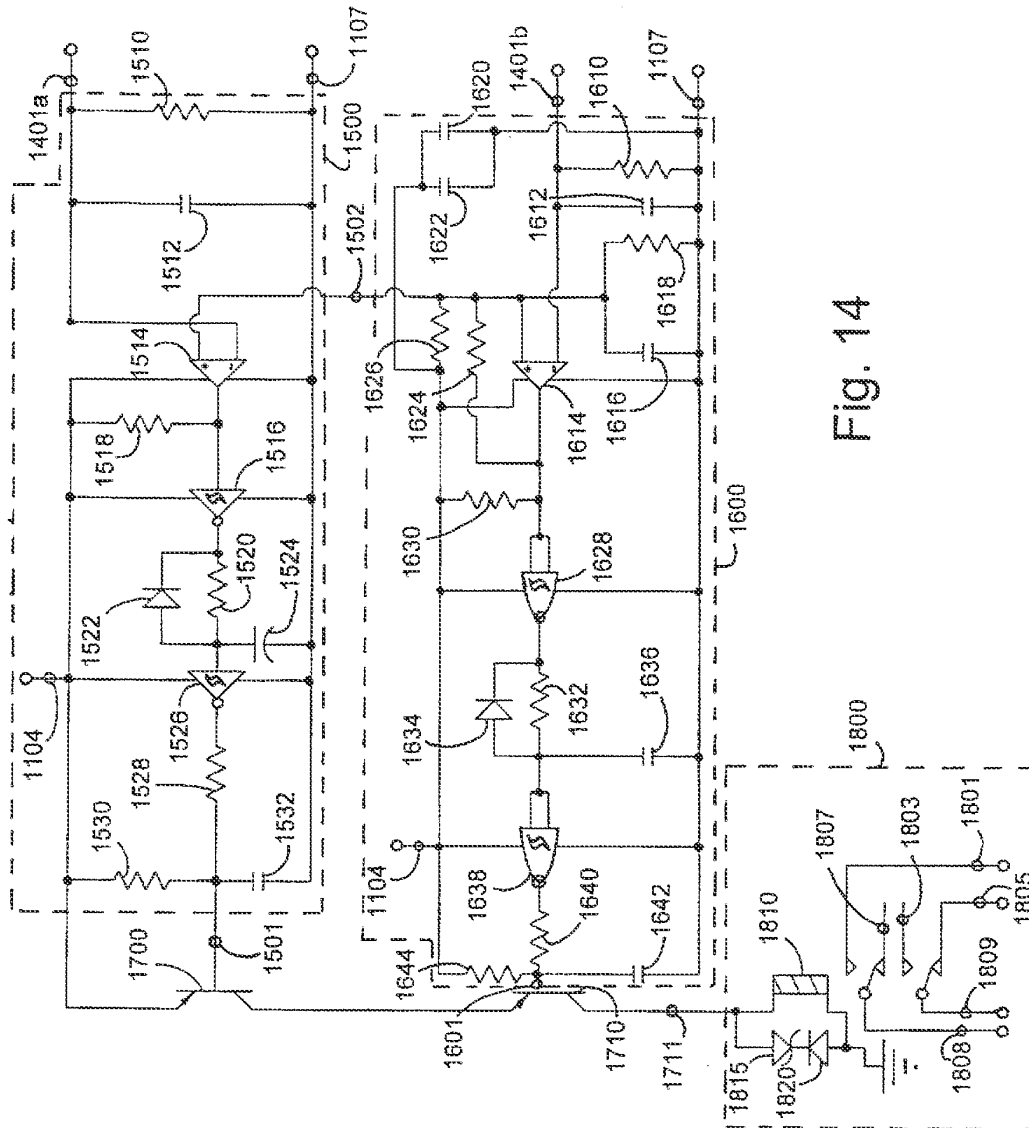

Fig. 14

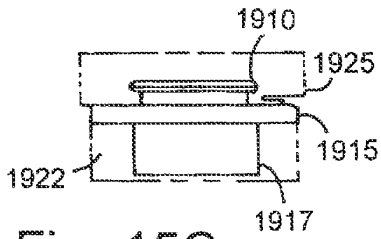
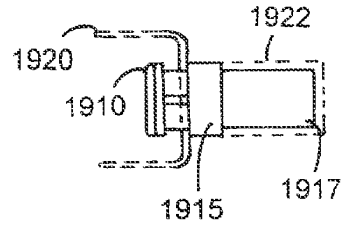
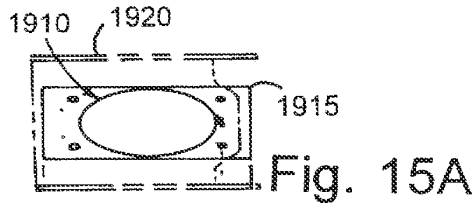

Fig. 15B

Fig. 15C

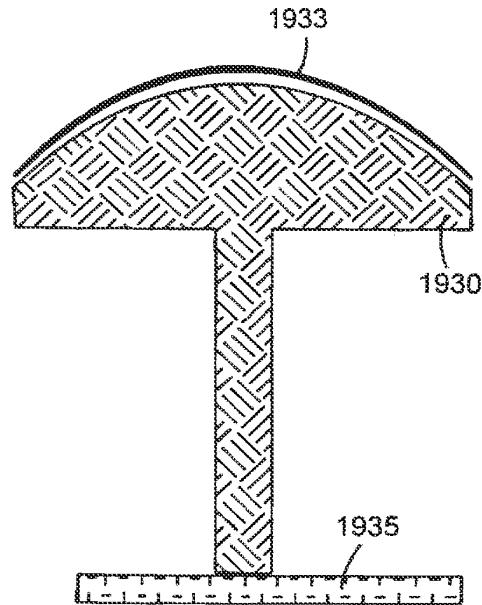

Fig. 16

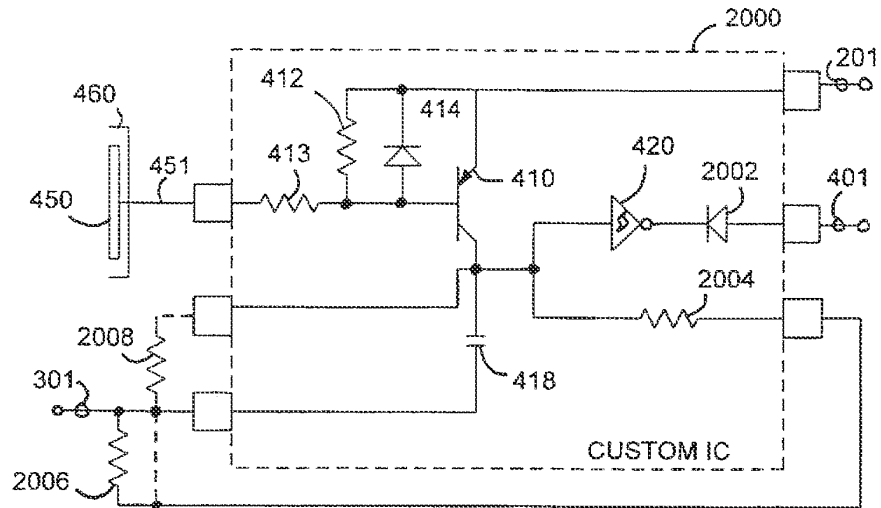

Fig. 17

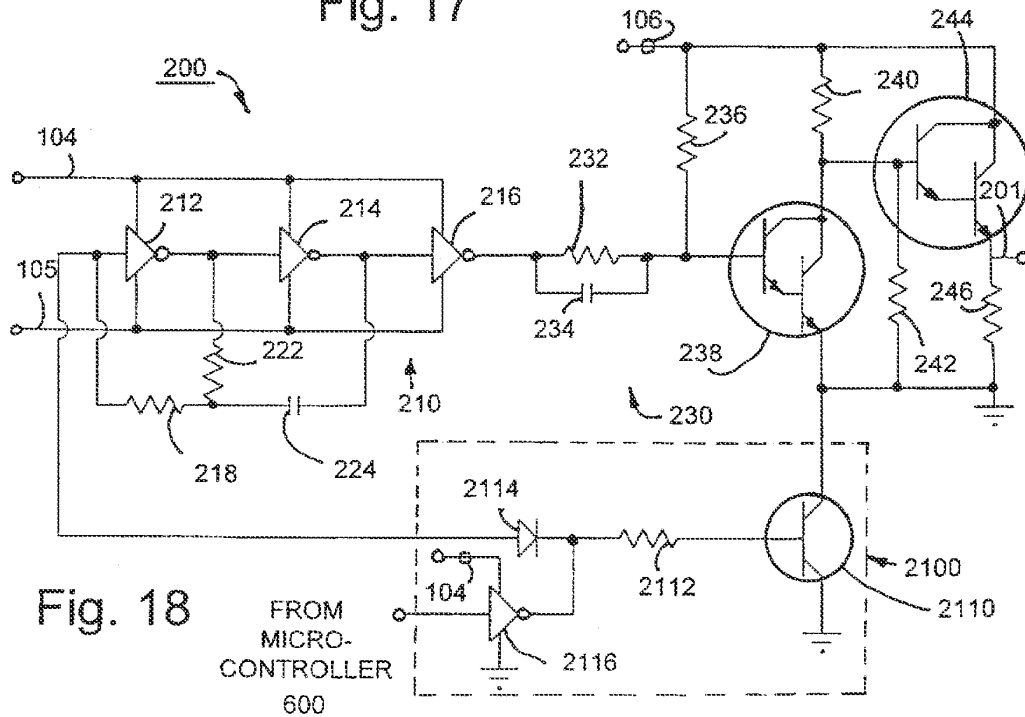
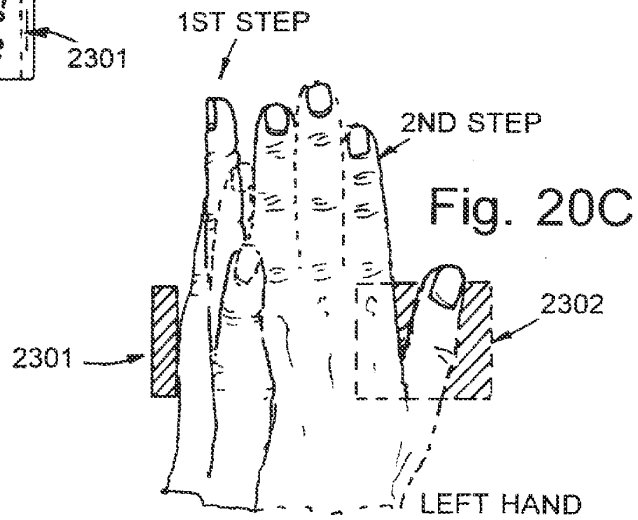
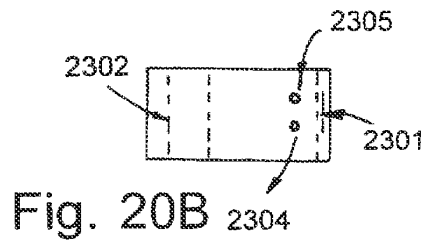
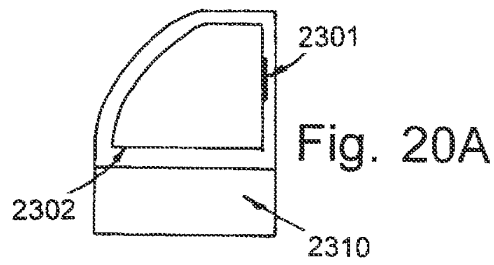
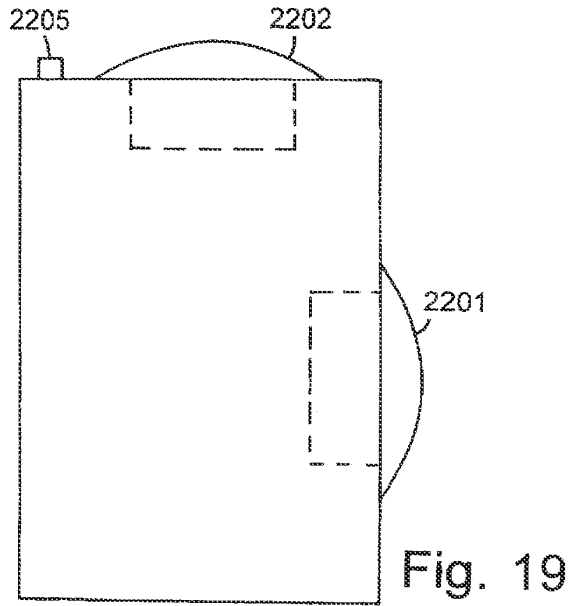

Fig. 18



CAPACITIVE RESPONSIVE ELECTRONIC SWITCHING CIRCUIT

BACKGROUND OF THE INVENTION

The present invention relates to an electrical circuit and particularly a capacitive responsive electronic switching circuit used to make possible a "zero force" manual electronic switch.

Manual switches are well known in the art existing in the familiar forms of the common toggle light switch, pull cord switches, push button switches, and keyboard switches among others. The majority of such switches employ a mechanical contact that "makes" and "breaks" the circuit to be switched as the switch is moved to a closed or an open condition.

Switches that operate by a mechanical contact have a number of well known problems. First, mechanical movements of components within any mechanism make those components susceptible to wear, fatigue, and loosening. This is a progressive problem that occurs with use and leads to eventual failure when a sufficient amount of movement has occurred.

Second, a sudden "make" or "break" between conductive contacts typically produces an electrical arc as the contacts come into close proximity. This arcing action generates both radio frequency emissions and high frequency noise on the line that is switched.

Third, the separation between contacts that occurs on each break, exposes the contact surfaces to corrosion and contamination. A particular problem occurs when the arc associated with a "make" or "break" occurs in an oxidizing atmosphere. The heat of the arc in the presence of oxygen facilitates the formation of oxides on the contact surfaces. Once exposed, the contact surfaces of mechanical switches are also vulnerable to contaminants. Water borne contaminants such as oils and salts can be a particular problem on the contact surfaces of switches. A related problem occurs in that the repeated arcing of mechanical contact can result in a migration of contact materials away from the area of the mechanical contact. Corrosion, contamination, and migration operating independently or in combination often lead to eventual switch failure where the switch seizes in a closed or opened condition.

An additional problem results from the mechanical force required in operating a mechanical switch. This problem occurs in systems where a human operator is required to repetitively operate a given switch or a number of switches. Such repetitive motions commonly occur in the operation of electronic keyboards such as those used with computers and in industrial switches such as used in forming and assembly equipment among other applications. A common type of industrial switch is the palm button seen in pressing and insertion equipment. For safety purposes, the operator must press the switch before an insertion or pressing can occur. This ensures that the operator's hand(s) is(are) on the button (s) and not in the field of motion of the associated machinery. It also ensures that the mechanical motion occurs at a desired and controllable point in time. The difficulty arises from the motion and force required of the operator. In recent years, it has been noted that repeated human motions can result in debilitating and painful wear on joints and soft tissues yielding arthritis like symptoms. Such repetitive motion may result in swelling and cramping in muscle tissues associated with conditions such as Carpal Tunnel Syndrome. Equipment designers combat these Repetitive Motion or Cumulative

Trauma Disorders by adopting ergonomic designs that more favorably control the range, angle, number, and force of motions required of an operator as well as the number of the operator's muscle groups involved in the required motions. Prosthetics and tests are used as well to provide strain relief for the operator's muscles, joints, and tendons.

In mechanical switches, the force required to actuate the switch may be minimized by reducing spring forces and frictional forces between moving parts. However, reducing such forces makes such switches more vulnerable to failure. For instance, weaker springs typically lower the pressure between contacts in a "make" condition. This lower contact pressure increases the resistance in the switch which can lead to fatal heating in the switch and/or loss of voltage applied to the switched load. Reducing frictional forces in the switch by increasing the use of lubricants is undesirable because the lubricants can migrate and contaminate the contact surfaces. A switch designer may also reduce friction by providing looser fits between moving parts. However, looser fits tend to increase wear and contribute to earlier switch failure. A designer can also reduce friction by using higher quality, higher cost, surface finishes on the parts. Thus, as apparent from the foregoing description, measures taken to reduce actuator force in mechanical switch parts generally reduce the reliability and performance of the switch and/or increase the cost of the switch.

In applications such as computer keyboards or appliance controls, the electric load switched by a given switch can be quite low in terms of current and/or voltage. In such cases it is possible to use low force membrane switches such as described in U.S. Pat. No. 4,503,294. Such switches can relieve operator strain and are not as susceptible to arcing problems because they switch small loads. However, the flexible membrane remains susceptible to wear, corrosion, and contamination. Although such switches require very low actuation force, they are still mechanically based and thus suffer from the same problems as any other mechanical switch.

A more recent innovation is the development of "zero force" touch switches. These switches have no moving parts and no contact surfaces that directly switch loads. Rather, these switches operate by detecting the operator's touch and then use solid state electronics to switch the loads or activate mechanical relays or triacs to switch even larger loads. Approaches include optical proximity or motion detectors to detect the presence or motion of a body part such as in the automatic controls used in urinals in some public rest rooms or as disclosed in U.S. Pat. No. 4,942,631. Although these non-contact switches are by their very nature truly zero force, they are not practical where a multiplicity of switches are required in a small area such as a keyboard. Among other problems, these non-contact switches suffer from the comparatively high cost of electro-optics and from false detections when the operator's hand or other body part unintentionally comes close to the switch's area of detection. Some optical touch keyboards have been proposed, but none have enjoyed commercial success due to performance and/or cost considerations.

A further solution has been to detect the operator's touch via the electrical conductivity of the operator's skin. Such a system is described in U.S. Pat. No. 3,879,618. Problems with this system result from variations in the electrical conductivity of different operators due to variations in sweat, skin oils, or dryness, and from variable ambient conditions such as humidity. A further problem arises in that the touch surface of the switch that the operator touches must remain clean enough to provide an electrical conductivity path to

the operator. Such surfaces can be susceptible to contamination, corrosion, and/or a wearing away of the conductive material. Also, these switches do not work if the operator is wearing a glove. Safety considerations also arise by virtue of the operators placing their body in electrical contact with the switch electronics. A further problem arises in that such systems are vulnerable to contact with materials that are equally or more conductive than human skin. For instance, water condensation can provide a conductive path as good as that of an operator's skin, resulting in a false activation.

A common solution used to achieve a zero force touch switch has been to make use of the capacitance of the human operator. Such switches, which are hereinafter referred to as capacitive touch switches, utilize one of at least three different methodologies. The first method involves detecting RF or other high frequency noise that a human operator can capacitively couple to a touch terminal when the operator makes contact such as is disclosed in U.S. Pat. No. 5,066,898. One common source of noise is 60 Hz noise radiated from commercial power lines. A drawback of this approach is that radiated electrical noise can vary in intensity from locale to locale and thereby cause variations in switch sensitivity. In some cases, devices implemented using this first method, rely on conductive contact between the operator and the touch terminal of the switch. As stated, such surfaces are subject to contamination, corrosion, and wear and will not work with gloved hands. An additional problem can arise in the presence of moisture when multiple switches are employed in a dense array such as a keyboard. In such instances, the operator may touch one touch terminal, but end up inadvertently activating others through the path of conduction caused by the moisture contamination.

A second method for implementing capacitive touch switches is to couple the capacitance of the operator into a variable oscillator circuit that outputs a signal having a frequency that varies with the capacitance seen at a touch terminal. An example of such a system is described in U.S. Pat. No. 5,235,217. Problems with such a system can arise where conductive contact with the operator is required and where the frequency change caused by a touch is close to the frequency changes that would result from unintentionally coming into contact with the touch terminal.

Another method for implementing capacitive touch switches relies on the change in capacitive coupling between a touch terminal and ground. Systems utilizing such a method are described in U.S. Pat. No. 4,758,735 and U.S. Pat. No. 5,087,825. With this methodology the detection circuit consists of an oscillator (or AC line voltage derivative) providing a signal to a touch terminal whose voltage is then monitored by a detector. The touch terminal is driven in electrical series with other components that function in part as a charge pump. The touch of an operator then provides a capacitive short to ground via the operator's own body capacitance that lowers the amplitude of oscillator voltage seen at the touch terminal. A major advantage of this methodology is that the operator need not come in conductive contact with the touch terminal but rather only in close proximity to it. A further advantage arises in that the system does not rely upon radiated emissions picked up by the operator's body which can vary with locale, but relies instead upon the human body's capacitance, which can vary over an acceptable range of 20 pF to 300 pF.

An additional consideration in using zero force switches resides in the difficulties that arise in trying to employ dense arrays of such switches. Touch switches that do not require physical contact with the operator but rather rely on the

operator's close proximity can result in unintended actuations as an operator's hand or other body part passes in close proximity to the touch terminals. Above-mentioned U.S. Pat. No. 5,087,825 employs conductive guard rings around the conductive pad of each touch terminal in an effort to decouple adjacent touch pads and prevent multiple actuations where only a single one is desired. In conjunction with the guard rings, it is also possible to adjust the detection sensitivity by adjusting the threshold voltage to which the sensed voltage is compared. The sensitivity may be adjusted in this manner to a point where the operator's body part, for instance, a finger, has to entirely overlap a touch terminal and come into contact with its dielectric facing plate before actuation occurs. Although these methods (guard rings and sensitivity adjustment) have gone a considerable way in allowing touch switches to be spaced in comparatively close proximity, a susceptibility to surface contamination remains as a problem. Skin oils, water, and other contaminants can form conductive films that overlay and capacitively couple adjacent or multiple touch pads. An operator making contact with the film can then couple multiple touch pads to his or her body capacitance and it's capacitive coupling to ground. This can result in multiple actuations where only one is desired. Small touch terminals placed in close proximity by necessity require sensitive detection circuits that in some cases are preferably isolated from interference with the associated load switching circuits that they activate.

As mentioned, in industrial controls, switches can be used to control actuation time and to ensure that the operator's hand(s) or other body part(s) are out of the field of motion of associated machinery. A common type of switch used in this application is the palm button. The button is large enough so that the operator can rapidly bring his or her hand into contact with the button without having to lose the time that would be taken in acquiring and lining up a finger with a smaller switch. Zero force touch switches are also desirable in this application as Repetitive Motion or Cumulative Trauma Disorders have been a problem with operator's utilizing palm buttons—especially those palm buttons that must be actuated against a spring resistance. In this area capacitive touch switches have also been employed. U.S. Pat. No. 5,233,231 is an example of such an implementation. Due to the proximity of machinery with the potential to cause injury, false actuations are a particular liability in such applications. Capacitive touch switches that exhibit vulnerability to radiated electromagnetic noise or that operate off operator proximity have the potential to actuate when the operator's hand(s) is not at the desired location on the palm button(s). In general, this is addressed by the use of redundancies. In U.S. Pat. No. 5,233,231, a separate detector is used to measure RF noise and disable the system to a safe state if excessive RF noise is present. Other systems such as UltraTouch vended by Pinnacle Systems, Inc. use redundant sensing methodologies. In UltraTouch, both optical and capacitive sensors are used and actuation occurs only when both sensor types detect the operator's hand at the desired location. These implementations have a number of disadvantages. In the case of the RF noise detection system, the system is unusable in the presence of RF noise. This forces the user to employ a backup mechanical switch system or accept the loss of function when RF noise is present. The second system is less reliable and more expensive because it requires two sensor systems to accomplish the same task, i.e., detect the operator. Such system may also suffer from problems inherent in any optical system, namely, susceptibility to blockages in the optical path and the need to achieve and maintain specific optical alignments. A further problem

is that this system considerably constrains the angle and direction of motion that the operator must use in activating the switch.

Currently, there are several zero force palm buttons in the market. These products utilize optical and/or capacitive coupling to activate a normally closed (NC) or a normally open (NO) relay, and thereby switching 110 V AC, 220 V AC, or 24 V DC to machine controllers. The UltraTouch by Pinnacle Systems Inc. uses two sensors (infrared & capacitive) with isolated circuits to activate a relay when a machine operator inserts his hand into a U-shaped sensor actuation tunnel. The company claims that by permitting the machine operator to activate the machine with no force or pressure and with the operator's hand and wrist in the ergonomic neutral position (i.e. 0° wrist joint angle and 100% hand power positions as shown in FIG. 1.0-1), hand, wrist, and arm stresses are minimized and contributing elements to Carpal Tunnel Syndrome are negated. After a machine cycle is initiated, the operator must maintain an initial posture until the cycle is completed. A typical cycle time lasts approximately one to two seconds and is repeated about 3000 times daily. This adds up to about one hour to one hour and a half per day while the operator is in the posture. While this module reduces stress on wrist and hand, it strains the muscles in the forearm. Also, because of limited space permitted for the operator to insert his hand, it stresses the operator mentally and reduces productivity by causing fatigue. Furthermore, the infrared emitters and detectors rely on a clean path between the transmitter and receiver and will not operate properly if contaminants block the beam of light.

SUMMARY OF THE INVENTION

The present invention overcomes the above problems by using the method of sensing body capacitance to ground in conjunction with redundant detection circuits. Additional improvements are offered in the construction of the touch terminal (palm button) itself and in the regime of body capacitance to ground detection which minimizes sensitivity to skin oils and other contaminants. The invention also allows the operator to utilize the system with or without gloves which is a particular advantage in the industrial setting.

The specific touch detection method of the present invention has similarities to the devices of U.S. Pat. No. 4,758,735 and U.S. Pat. No. 5,087,825. However, significant improvements are offered in the means of detection and in the development of an overall system to employ the touch switches in a dense array and in an improved zero force palm button. The touch detection circuit of the present invention features operation at frequencies at or above 50 kHz and preferably at or above 800 kHz to minimize the effects of surface contamination from materials such as skin oils and water. It also offers improvements in detection sensitivity that allow close control of the degree of proximity (ideally very close proximity) that is required for actuation and to enable employment of a multiplicity of small sized touch terminals in a physically close array such as a keyboard. The circuitry of the present invention minimizes the force required in human operator motions and eliminates awkward angles and other constraints required in those motions. The outer surface of the touch switch typically consists of a continuous dielectric layer such as glass or polycarbonate with no mechanical or electrical feed-throughs. The surface can be shaped to have no recesses that would trap or hold organic material. As a result it is easily cleaned and kept clean and so is ideal for hygienic applications such as medical or food processing equipment.

In a first preferred embodiment the circuit offers enhanced detection sensitivity to allow reliable operation with small (finger size) touch pads. Susceptibility to variations in supply voltage and noise are minimized by use of a floating common and supply that follow the oscillator signal to power the detection circuit. The enhanced sensitivity allows the use of a 26V or lower amplitude oscillator signal applied to the touch terminal and detection circuit. This lower voltage (as compared to the device of U.S. Pat. No. 4,758,735) obviates the need for expensive UL listed higher voltage construction measures and testing to handle what would otherwise be large enough voltages to cause safety concerns. A further advantage of the present invention is seen in the manner in which the touch terminal detection circuit is interfaced to the touch terminals and to external control systems. A dedicated microprocessor referenced to the floating supply and floating common of the detection circuit maybe used to cost effectively multiplex a number of touch terminal detection circuits and multiplex the associated touch terminal output signals over a two line optical bus to a dedicated microprocessor referenced to a fixed supply and ground. An additional advantage of the microprocessor is an expanded ability to detect faults, i.e. a pad that is touched for an excessive amount of time that is known a priori to be an unlikely mode of operation or two or more pads touched at the same time or in an improper order. Additionally, the microprocessor can be used to distinguish desired multiple pad touches in simultaneous or sequential modes, i.e. two or more switches touched in a given order within a given amount of time. The microprocessor can be used to perform system diagnostics as well. The microprocessor also allows the use of visual indicators such as LEDs or annunciators such as a bell or tone generator to confirm the actuation of a given touch switch or switches. This is particularly useful in cases where a sequence of actuations is required before an action occurs. The feedback to the operator provided by a visual or audio indicator activated by the microprocessor in response to intermediate touches in a required sequence can minimize time lost and/or frustration on the part of the operator due to failed actuations from partial touches or wrong actuations from touching the wrong pad in a given required sequence or combination of touches. The second microprocessor may be used to communicate with the user's control system. Additional features include a "sleep mode" to minimize power consumption during periods of non-use or power brown outs, and redundant control circuits to facilitate "fail to safe" operation. Another improvement is offered in a means to move much of the cost of the system into simplified custom integrated circuits that allow ease of sensitivity adjustment and assembly.

In a second preferred embodiment, an improved palm button is featured. Through the use of a dielectric cover, a large metallic touch terminal can be used that differentiates between the touch of a finger or partial touch and the full touch of a palm. In this way the system avoids false triggers due to inadvertent finger touches or brushing contact with the palm prior or after an intended touch. The second embodiment also features redundant control circuits to facilitate "fail to safe" operation.

To achieve these and other advantages, and in accordance with the purpose of the invention as embodied and described herein, the capacitive responsive electronic switching circuit comprises an oscillator providing a periodic output signal having a frequency of 50 kHz or greater, an input touch terminal defining an area for an operator to provide an input by touch, and a detector circuit coupled to the oscillator for receiving the periodic output signal from the oscillator, and

coupled to the input touch terminal. The detector circuit being responsive to signals from the oscillator and the presence of an operator's body capacitance to ground coupled to the touch terminal when touched by an operator to provide a control output signal. Preferably, the oscillator provides a periodic output signal having a frequency of 800 kHz or greater.

These and other features, objects, and advantages of the invention may be realized and obtained by means of the instrumentalities and combinations particularly pointed out in the written description and claims hereof, as well as by the appended drawings.

BRIEF DESCRIPTION OF THE DRAWINGS

FIG. 1 is an electrical schematic of a testing circuit used to measure the impedance of the human body;

FIG. 2 is an electrical schematic of a testing circuit used to measure the impedance of water;

FIG. 3 is an electrical schematic of an equivalent circuit model for analyzing a human body in contact with glass covered with water;

FIG. 4 is a block diagram of a capacitive responsive electronic switching circuit constructed in accordance with a first embodiment of the present invention;

FIG. 5 is an electrical schematic of a preferred voltage regulator circuit for use in the capacitive responsive electronic switching circuit shown in FIG. 4;

FIG. 6 is an electrical schematic of a preferred oscillator circuit for use in the capacitive responsive electronic switching circuit shown in FIG. 4;

FIG. 7 is an electrical schematic of a preferred floating common generator circuit for use in the capacitive responsive electronic switching circuit shown in FIG. 4;

FIG. 8 is an electrical schematic of a preferred touch circuit for use in the capacitive responsive electronic switching circuit shown in FIG. 4;

FIG. 9 is a three dimensional bar graph illustrating signal-to-noise ratio vs. body capacitance at $T=105^{\circ}\text{C}$;

FIG. 10 is a three dimensional bar graph illustrating signal-to-noise ratio vs. body capacitance at $T=22^{\circ}\text{C}$;

FIG. 11 is a block diagram of a capacitive responsive electronic switching circuit constructed in accordance with a second embodiment of the present invention;

FIG. 12 is a block diagram of a capacitive responsive electronic switching circuit constructed in accordance with a third embodiment of the present invention;

FIG. 13 is an electrical schematic of a preferred voltage regulator, oscillator, and touch circuits for use in the capacitive responsive electronic switching circuit shown in FIG. 12;

FIG. 14 is an electrical schematic of preferred driver circuits for use in the capacitive responsive electronic switching circuit shown in FIG. 12;

FIGS. 15A-C are top, side, and front views, respectively, of an example of a flat palm button constructed in accordance with the present invention;

FIG. 16 is a cross-sectional view of an example of a dome-shaped palm button constructed in accordance with the present invention;

FIG. 17 is an electrical schematic of a touch circuit of the present invention implemented in a custom integrated circuit;

FIG. 18 is an electrical schematic of an oscillator having a sleeper circuit for use in the capacitive responsive electronic switching circuits of the present invention;

FIG. 19 is a pictorial view of a device having two palm buttons and an indicator light operated in accordance with the present invention; and

FIGS. 20A-C are pictorial views of another embodiment of the device shown in FIG. 19.

DETAILED DESCRIPTION OF THE PREFERRED EMBODIMENTS

As apparent from the above summary, the touch circuit of present invention operates at a higher frequency than prior touch sensing circuits. A move to high frequency operation (>50 to 800 kHz) is not a benign choice relative to the lower frequency (60 to 1000 Hz) operation seen in existing art such as U.S. Pat. No. 4,758,735 and U.S. Pat. No. 5,087,825. Higher frequencies require generally more costly, higher speed parts, and often results in the added cost of special design measures to minimize electronic emissions and the introduction of high frequency noise on power supply lines. The preference for using such higher frequencies is based on a study performed to determine if high frequency operation would allow a touch of an operator and conduction via surface contamination films, such as moisture, providing a conductive path from a non-touched area to the touched area. The study also determined whether a high frequency touch circuit could operate over a sufficiently wide temperature range, an assortment of overlying dielectric layer thicknesses and materials, and in the presence of likely power supply fluctuations. The following calculations and measurements are the results of this study. The results summarize the investigation conducted to reduce crosstalk due to condensation of water on the dielectric member (glass). By increasing the frequency of operation, the impedance of the body-glass combination is reduced as compared to the impedance of water between the touch pads.

The equivalent circuit of body impedance was measured using the testing circuit 10 shown in FIG. 1. Testing circuit 10 includes an oscillator 20 coupled between ground plane and a 100 k Ω series resistor 22 and in parallel with a 10 M Ω resistor 24, a 20 pF capacitor 26, and contacts for connecting to a human body identified in the figure as an impedance load 15 having an impedance Z_B representing the body's impedance.

Two types of measurements were taken: one with the person under test standing on a large ground plane i.e., concrete slab; and another while standing on a subfloor. The subfloor was used to simulate a typical northern home, i.e., wood joists with plywood sheeting. Carpeting was used as an added insulation layer. Table 1 below shows the measured body resistance and capacitance for five individuals.

TABLE 1

CONCRETE SLAB	CONCRETE SLAB	SUBFLOOR	SUBFLOOR
1.4 k Ω	100 pF	1.7 k Ω	73 pF
1.4 k Ω	217 pF	1.9 k Ω	78 pF
1.3 k Ω	174 pF	1.9 k Ω	93 pF
1.2 k Ω	160 pF	1.6 k Ω	85 pF
1.0 k Ω	107 pF	1.4 k Ω	75 pF

As apparent from Table 1 above and the discussion to follow, a human body's impedance may be represented by the series combination of a 20-300 pF capacitor and a 1 k-2 k Ω resistor.

The impedance of water, which is mainly resistive, was measured using the testing circuit 30 shown in FIG. 2. Testing circuit 30 includes an oscillator 40 coupled in series with a 1 M Ω resistor 42 and contacts across which water is

applied to define an impedance load 35 having an impedance Z_w , representing the impedance of water. A true RMS voltage meter 45 is connected across the contacts of the impedance load 35.

The resistance of tap water over a 1x1 inch area and 1/32 inch deep, was measured to be around 160 kΩ.

The following calculation is for resistance of rain water where c is the conductivity for rain:

$$R = \left(\frac{1}{cin} \right) \times \left(\frac{L}{A} \right)$$

where,

$$c = 128 \times 10^{-6} (\Omega \cdot \text{cm})^{-1}$$

$$cin = c \left(\frac{100 \text{ cm}}{\text{m}} \right) \left(\frac{.0254 \text{ m}}{\text{in}} \right)$$

$$L = 1.0 \text{ in}$$

$$A = (1.0) \times \left(\frac{1}{32} \right) = \frac{1}{32} \text{ in}^2$$

therefore,

$$R = \left(\frac{1}{325.12 \times 10^{-6}} \right) \times \left(\frac{1.0 \text{ in}}{\frac{1}{32} \text{ in}^2} \right) = 98.43 \text{ k}\Omega$$

However, the thickness of a layer of water condensed on the surface of glass is much less than 1/32 inch and its resistance is higher than that of tap water. For design purposes, a resistance value of 1 MΩ was used to simulate water.

The capacitance of a piece of glass measuring 1/2"x1/2"x1/4", is approximately 2 pF.

$$C = K_{glass} K_v \frac{A(\text{cm}^2)}{L(\text{cm})} (\mu\text{F})$$

$$K_v = 0.08842 \times 10^{-6} \text{ for vacuum}$$

$$6.0 < K_{glass} < 10$$

$$A = 0.25 \text{ in}^2$$

$$L = 0.25 \text{ in}$$

therefore,

$$C_{max} = 10 \times 0.08842 \times 10^{-6} \times 2.54 \times 10^{-6} = 2.25 \text{ pF}$$

$$C_{min} = 6 \times 0.08842 \times 10^{-6} \times 2.54 \times 10^{-6} = 1.35 \text{ pF}$$

Table 2 below shows the dielectric constant for several types of glass:

TABLE 2

TYPE OF GLASS	Dielectric Constant (K)
Corning 0010	6.32
Corning 0080	6.75
Corning 0120	6.65
Corning 8870	9.5

The equivalent circuit 50 of body touching the glass with the presence of water is shown in FIG. 3. As shown, the equivalent circuit 50 includes a polycarbon (PCB) plate 55 having at least two pads 57 and 59 formed thereon, a glass plate 60 adjacent to PCB plate 55, water 65 on glass plate 60 spanning at least two touch pad areas, and a body 70 in

contact with the water 65 and glass plate 60 at one touch pad area. The impedance of glass plate 60 is approximated by two 2 pF capacitors 62 and 64 connected to pads 57 and 59, respectively. The water 65 is approximated by a 1 MΩ resistor 68 connected between capacitors 62 and 64. The body is represented by a 20-300 pF capacitor 72 coupled at one end to water resistor 68 and glass plate capacitor 62, and by a 1-2 kΩ resistor 74 coupled between the other end of capacitor 72 and ground.

Referring to FIG. 3, it can be seen that a human touch opposite pad 57 will couple pad 57 to ground through the capacitance of glass 62 and the series contact with the human body impedance provided by the 20-300 pF capacitance and the 1 k-2 kΩ resistance of a typical human body. This will have the effect of pulling any voltage on the pad towards ground. Pad 59 will be similarly effected, however it's coupling to ground will not only be through capacitance 64, and the series capacitance and resistance of the human body, but will also be through the ohmic resistance of water on the glass cover between the proximate location of pad 59 and the touched pad 57. Because the human capacitance is considerably greater than the 2 pF capacitance of the glass, the impedance of the path to ground for pads 57 and 59 will be dominated by the glass and water impedances. If the impedance of the water path is significant compared to that of the glass, then the effect of a touch will be more significant at pad 57 than at pad 59. To overcome the effect of condensation or possible water spills, the impedance of the glass is preferably made as small as is practical compared to the impedance of the water. This allows discrimination between touched and adjacent pads. As the water impedance is primarily resistive and the glass impedance is primarily capacitive, the impedance of the glass will drop with frequency.

FIG. 3A shows the maximum and minimum glass impedance as a function of frequency. The maximum and minimum glass impedances shown were computed as follows:

$$\sigma_g = 8.854 \times 10^{-12} C^2 / (\text{mm}^2)$$

$$K_{gmin} = 6$$

$$K_{gmax} = 10$$

$$A = 0.25 \text{ in}^2$$

$$L = 0.25 \text{ in}$$

$$C_{max} = K_{gmax} \sigma_g A / L, C_{max} = 2.249 \text{ pF}$$

$$C_{min} = K_{gmin} \sigma_g A / L, C_{min} = 1.349 \text{ pF}$$

$$Z_{gmin_frequency} = 1 / (2 \pi C_{max} \text{frequency})$$

$$Z_{gmax_frequency} = 1 / (2 \pi C_{min} \text{frequency})$$

As can be seen, at 1 kHz, the capacitive impedance of the glass is much greater than the nominal 1 MΩ of the water bridge between the pads. As a result, at 1 kHz, there would be little difference in the impedance paths to ground of the two adjacent pads when either is touched. This would result in the voltage on both pads being pulled towards ground by comparable amounts. Conversely, at 100 kHz, the glass impedance drops to approximately 1 MΩ resulting in the impedance of the path to ground for pad 59 being twice that of the touched pad 57. For cases where background noise and temperature drifts are comparatively small, a 100 kHz oscillator frequency would allow a sufficiently low detection threshold to be set to differentiate between the signal changes induced at both pads by a human touch opposite a

single pad. At 800 kHz, the impedance of the glass drops to 200 k Ω or lower giving a ratio of a greater than 5 to 1 impedance difference between the paths to ground of the touched pad 57 and adjacent pads 59. In fact, the impedance ratio may exceed 10 to 1, as illustrated in the calculation below. This allows the detection threshold for the touched pad to be set well below that of an adjacent pad resulting in a much lower incidence of inadvertent actuation of adjacent touch pads to that of the touched pad. Ideally, the frequency of operation would be kept at the 800 kHz of the preferred embodiment or even higher. However, as noted earlier, higher frequency operation forces the use of more expensive components and designs. For applications where thermal drift and electronic noise levels are low, operation at or near 100 kHz may be possible. However, at 10 kHz and below, the impedance of the glass becomes much greater than that of likely water bridges between pads resulting in adjacent pads being effected as much by a touch as the touched pad itself. Although the preferred frequency is at or above 100 kHz, and more preferably at or above 800 kHz, it is conceivable that frequencies as low as 50 kHz could be used provided the frequency creates a difference in the impedance paths of adjacent pads that is sufficient enough to accurately distinguish between an intended touch and the touch of an adjacent pad. Use of frequencies as low as 50 kHz may also be possible depending upon the type of glass or covering or the thickness thereof used for the touch pad. However, in cases where there is little or no surface contamination, the frequency of operation can go well below 50 kHz. Ultimately, the frequency chosen will be a tradeoff between the likelihood of surface contamination and the cost of going to higher frequencies to prevent cross talk due to such contamination. The following analysis illustrates one example of how a frequency may be calculated based on the typical parameters used to construct a touch switch and the typical impedance of a contaminant, such as rain water. In the analysis below a 10 to 1 ratio of water to glass impedance is sought.

To eliminate crosstalk due to condensation of water on the glass, the impedance of body (Z_B) and glass (Z_g) combination must be much lower than impedance of water (Z_w). Since the impedance of glass is much higher than body impedance, Z_g will be considered only. Therefore,

$$10Z_g < 1Z_w \quad \text{Eq. 3}$$

where,

$$C_{glass} = 2 \text{ pF} \quad Z_w = 1 \text{ M}\Omega$$

$$Z_g = \frac{1}{2\pi f C_g} = \frac{7.96 \times 10^{10}}{f} \quad \text{Eq. 4}$$

$$10 \times \left(\frac{7.96 \times 10^{10}}{f} \right) < 1 \text{ M}\Omega$$

Therefore,

$$f > 796 \text{ kHz}$$

Having provided a basis for the use of higher frequencies, the basic construction of the electronic switching circuit constructed in accordance with a first embodiment of the present invention is now described with reference to FIG. 4. The electronic switching circuit includes a voltage regulator 100 including input lines 101 and 102 for receiving a 24 V AC line voltage and a line 103 for grounding the circuit. Voltage regulator 100 converts the received AC voltage to a

DC voltage and supplies a regulated 5 V DC power to an oscillator 200 via lines 104 and 105. Voltage regulator also supplies oscillator 200 with 26 V DC power via line 106. The details of voltage regulator 100 are discussed below with reference to FIG. 5.

Upon being powered by voltage regulator 100, oscillator 200 generates a square wave with a frequency of 50 kHz, and preferably greater than 800 kHz, and having an amplitude of 26 V peak. The square wave generated by oscillator 200 is supplied via line 201 to a floating common generator 300, a touch pad shield plate 460, a touch circuit 400, and a microcontroller 500. Oscillator 200 is described below with reference to FIG. 6.

Floating common generator 300 receives the 26 V peak square wave from oscillator 200 and outputs a regulated floating common that is 5 volts below the square wave output from oscillator 200 and has the same phase and frequency as the received square wave. This floating common output is supplied to touch circuit 400 and microcontroller 500 via line 301 such that the output square wave from oscillator 200 and floating common output from floating common generator 300 provide power to touch circuit 400 and microcontroller 500. Details of floating common generator 300 are discussed below with reference to FIG. 7.

Touch circuit 400 senses capacitance from a touch pad 450 via line 451 and outputs a signal to microcontroller 500 via line 401 upon detecting a capacitance to ground at touch pad 450 that exceeds a threshold value. The details of touch circuit 400 are described below with reference to FIG. 8.

Upon receiving an indication from touch circuit 400 that a sufficient capacitance to ground (typically at least 20 pF) is present at touch pad 450, microcontroller 500 outputs a signal to a load-controlling microcontroller 600 via line 501, which is preferably a two way optical coupling bus. Microcontroller 600 then responds in a predetermined manner to control a load 700. Having generally described the basic construction of the first embodiment, the preferred detailed construction of the depicted components will now be described with FIGS. 5-8. In cases where the number of lines to be switched is low, microcontroller 600 can be replaced by additional optical coupling lines. The number of lines to be switched will dictate whether it is more cost effective to multiplex over a two line optical bus such as line 501 and use a microcontroller to demultiplex, or to use a multiplicity of optical coupling lines. Other considerations such as reliability and power consumption may also affect this choice. In this preferred embodiment, the use of a single pair of optical coupling paths (line 501) and a microcontroller 600, is shown to emphasize the capability to switch a large number of lines.

A preferred circuit for implementing a voltage regulator 100 is shown in FIG. 5. Voltage regulator 100 preferably includes an AC/DC converter 110 for generating 29 V to 36 V unregulated DC on line 119. This unregulated DC power is supplied to a 5 V DC regulator 120 and to a 26 V DC regulator 130. AC/DC converter 110 includes diodes 112, 114, 116, and 118, which rectify the supplied 24 V AC power provided on power lines 101 and 102. The anode of the first diode 112 is coupled to power line 101 and to the cathode of the second diode 114. The cathode of the first diode 112 is coupled to output line 119. The anode of the second diode 114 is coupled to ground via line 103 and to the anode of the fourth diode 118. The anode of the third diode 116 is coupled to the cathode of the fourth diode 118 and to power line 102. The cathode of the third diode 116 is coupled to line 119 and to the cathode of the first diode 112. The anode of the fourth diode 118 is coupled to ground via line 103. Diodes 112, 114, 116, and 118 are preferably diodes having part no. 1N4002

available from LITEON. AC/DC convertor 110 also preferably includes a capacitor 115 for filtering the rectified output of the diodes. Capacitor 115 is preferably a 1000 μF capacitor coupled between output line 119 and ground via line 103.

The 5 V regulator 120 preferably includes a 500 Ω resistor 122 coupled between line 119 and 5 V output line 104, and a zener diode 124, a first capacitor 126, and second capacitor 128 all connected and parallel between output power lines 104 and 105. Preferably, zener diode 124 is a 5.1 V zener diode having part no. 1N4733A available from LITEON, first capacitor 126 has a capacitance of 10 μF , and second capacitor 128 has a capacitance of 0.1 μF .

The 26 V regulator 130 preferably includes a transistor 134 having a collector connected to line 119 via a first resistor 132, a base connected to line 119 via a second resistor 136, and an emitter coupled to the regulated 26 V output power line 106. The 26 V regulator 130 also preferably includes a capacitor 137 and zener diode 138 connected in parallel between the base of transistor 134 and ground line 103. Preferably, first resistor 132 is a 20 Ω , 0.5 W resistor, second resistor 136 is a 1 k Ω , 0.5 W resistor, capacitor 137 is a 0.1 μF capacitor, and zener diode 138 is a 27 V, 0.5 W diode having part no. 1N5254B available from LITEON. It will be apparent to those skilled in the art, that various components of voltage regulator 100 may be added or excluded depending upon the source of power available to power the oscillator 200. For example, if the available power is a 110 V AC 60 Hz commercial power line, a transformer may be added to convert the 110 V AC power to 24 V AC. Alternatively, if a DC battery is used, the AC/DC convertor among other components may be eliminated.

A preferred example of an 800 kHz oscillator is shown in FIG. 6. Oscillator 200 preferably includes a square wave generator 210, which is powered by 5 V regulator 120 via lines 104 and 105, for generating a 5 V peak square wave having the desired frequency, and a buffer circuit 230 powered by 26 V regulator 130 via line 106 for buffering the output of square wave generator 210 and boosting its peak from 5 V to 26 V while maintaining the preferred frequency. Square wave generator 210 is preferably an astable multivibrator constructed with at least two serially connected inverter gates 212 and 214, and optionally, a third serially connected inverter gate 216. Inverter gates 212, 214 and 216 are preferably provided in a single integrated circuit designated as part 74HC04 available from National Semiconductor. The output of the first inverter gate 212 is coupled to its input via resistors 218 and 222 and is coupled to the output of the second inverter gate 214 via a capacitor 224. The input of the second inverter gate 214 is directly connected to the output of the first inverter gate 212 and the output of the second inverter gate 214 is directly connected to the input of the optional third inverter gate 216. To provide an 800 kHz output, resistor 218 preferably has a 10.0 k Ω value, resistor 222 preferably has a 1.78 k Ω value, and capacitor 224 is preferably a 220 pF capacitor.

The 5 V peak square wave generated by square wave generator 210 is supplied from either the output of inverter gate 214 or the output of optional inverter gate 216 to the base of a first transistor 238 via a first resistor 232 connected and parallel a capacitor 234. The base of first transistor 238 is connected to the 26 V regulated DC power line 106 via a second resistor 236. The collector of first transistor 238 is connected to 26 V power line 106 via a third resistor 240 and to the base of a second transistor 244. The emitter of first transistor 238 is coupled to ground and to its own collector and the base of second transistor 244 via a fourth resistor 242. The collector of the second transistor 244 is connected

directly to 26 V power line 106 and the emitter of second transistor 244 is connected to ground via a fifth resistor 246. Second transistor 244 provides the 26 V peak square wave on output line 201, which is connected to its emitter. In operation, the square wave signal applied to the base of transistor 238 causes the collector of transistor 238 to swing between near to the DC supply 106 voltage and the collector-emitter saturation voltage. Capacitor 234 is provided to improve the turning off of transistor 238. Transistor 244 along with resistors 242 and 246 are used to buffer the square wave signal generated by transistor 238. In a preferred embodiment, the values of the resistors and capacitor are as follows: first resistor 232 is 5.1 k Ω , capacitor 234 is 0.0047 μF , second resistor 236 is 1 M Ω , third resistor 240 is 1.6 k Ω , fourth resistor 242 is 100 k Ω , and fifth resistor 246 is 4.7 k Ω . Preferably, transistors 238 and 244 are those identified as part no. ZTX600 available from ZETEX. In this configuration, the oscillator 200 sources 80 mA to the floating common generator 300 such that together they supply a floating 5 V DC to power touch circuit(s) 400, microcontroller 500, and Schmitt triggered gates 420 (FIG. 8). As will be apparent to those skilled in the art, the values of the resistors and capacitors utilized in oscillator 200 may be varied from those disclosed above to provide for different oscillator output frequencies. As discussed above, however, oscillator 200 is preferably constructed so as to output a square wave having a frequency of 50 kHz or greater, and more preferably, of 800 kHz or greater. In some cases it may be necessary to use lower gain bandwidth product transistors or filtration to achieve a softer roll-off of the square edges to reduce high frequency noise emissions. When this is done the amplitude of the oscillator voltage can be increased to compensate.

The preferred construction of floating ground generator 300 is shown in FIG. 7 includes a zener diode 310 having a cathode connected to the oscillator output on line 201 and an anode connected to floating ground output line 301 and to ground via resistor 316 and diode 318. Floating ground generator 300 also preferably includes a first capacitor 312 and a second capacitor 314 connected in parallel with zener diode 310. In the preferred embodiment, zener diode 310 is a 5.1 V zener diode identified by part no. 1N4733A available from LITEON, capacitor 312 is a 47 μF tantalum capacitor, capacitor 314 is a 0.1 μF capacitor, resistor 316 is a 270 Ω resistor, and diode 318 is a diode identified as part no. 1N914B available from LITEON.

Touch circuit 400, as shown in FIG. 8, preferably includes a transistor 410 having a base connected to touch pad 450 via resistor 413 and line 451, an emitter coupled to oscillator output line 201, and a collector coupled to floating ground line 301 via a pulse stretcher circuit 417, which includes a resistor 416 and a capacitor 418 connected in parallel. To minimize susceptibility to noise, the physical length of the path between the touch pad 450 and the base of the transistor 410, must be held to a minimum. Additionally, RC filters can be placed in line 401 between the output of the touch circuit 400 and the input of the microcontroller 500 to give additional EMI/RFI immunity. Additionally, the higher the frequency, the higher the gain bandwidth product that is required in transistor 410. The gain bandwidth product must be sufficient to guarantee that the oscillator turns on during oscillator High pulses. A further trade-off is to use higher gain bandwidth product to allow lower oscillator voltages or higher oscillator voltages to all allow a lower gain bandwidth product transistor to be used. The combination of oscillator voltage, frequency and transistor gain bandwidth product that is used will necessarily vary with the cost,

safety and reliability requirements of a given application. The present combination was chosen to keep the oscillator voltage down and allow operation at 800 kHz to minimize cross talk. At higher frequencies a higher gain bandwidth product transistor would be required in both the oscillator 200 and detection 400 circuits. Touch circuit 400 also preferably includes resistor 412 and a diode 414 having an anode connected to the base of transistor 410 and to resistor 413, and a cathode connected to the emitter of transistor 410 and to a resistor 412 connected in parallel with diode 414 between the base and emitter of transistor 410. The pulse stretcher circuit 417 is identified as such because the sensitivity of the touch circuit may be increased or decreased by varying the resistance of resistor 416. The base of transistor 410 is connected via resistor 413 to line 451 connected to touch pad 450.

Additionally, touch circuit 400 may include at least one Schmitt triggered gate 420 powered by the voltage difference existing between oscillator line 201 and 301, and having an input terminal coupled to the collector of transistor 410 and an output coupled to microcontroller 500 via output line 401. Schmitt triggered inverter gate 420 is optionally provided to improve the rise time of the touch switch output and to buffer the output. Preferably, transistor 410 is part no. BC858CL available from Motorola, resistor 412 is a 12 M Ω resistor, diode 414 is part no. 1N914B available from Diodes, Inc., resistor 416 is a 470 k Ω resistor, capacitor 418 is a 0.001 μ F capacitor, and resistor 413 is a 10 k Ω resistor.

As stated above, the operator's body includes a capacitance to ground, which may range in a typical person from between 20 to 300 pF. The base terminal of transistor 410 is coupled to its emitter by resistor 412 such that unless capacitance is present by the user touching the touch pad 450, transistor 410 will not be forward biased and will not conduct. Thus, when touch pad 450 is not touched, the output signal at the collector terminal of transistor 410 and across pulse stretcher circuit 417 will be zero volts. When, however, a person touches the touch pad 450, that person's body capacitance to ground couples the base of transistor 410 to ground 103 through resistor 413, thereby forward biasing transistor 410 into conduction. This charges capacitor 418 providing a positive DC voltage with respect to the line 301 and causes the output of the Schmitt trigger 420 to go low. Diode 414 is coupled across the base to emitter junction of transistor 410 to clamp the base emitter reverse bias voltage to -0.7 V and also reduce the forward recovery and turn-on time.

Touch pad 450 includes a substrate on which a plurality of electrically conductive plate members are mounted on one surface thereof. The substrate is an insulator and the plates are spaced apart in order to insulate the plates from one another and from ground. Also, positioned on the substrate is a guard band, generally shown as 460. Guard band 460 is a grid of conductor segments extending between adjacent pairs of plate members. All conductor segments are physically interconnected to define a plurality of spaces with one plate member positioned centrally within each space. Components of the touch circuit may be positioned on the side of substrate opposite plate members and guard band 460.

A planar dielectric member is spaced from the substrate facing plate members. The dielectric member is made from a non-porous insulating material such as polycarbonate or glass. A plurality of electrically conductive spring contacts are sandwiched between the inner surface of the dielectric member and the substrate. An indicia layer may be adhered to the inner surface of the dielectric member to provide an indication of the function of each input portion.

As mentioned above, interface between the dielectric member and a conductive plate is a metallic spring contact that is attached to the back of the dielectric member. The spring contacts offer advantages at high temperature extremes. However, for sufficiently narrow temperature ranges, conductive polymer foam pads cut to the size of the touch pads are preferably used to fill the gap between conductive pad and dielectric layer. The function of the spring contacts or conductive foam pads is to eliminate that capacitive contribution of the air filled gap between the conductive pads and the overlying dielectric layer.

A problem with capacity responsive keyboards is the tendency of switches that are closely positioned in a keyboard system to inadvertently become actuated even though the user is touching an adjacent switch. Furthermore, this problem is greatly aggravated by the presence of contamination on the outer surface of dielectric member. Contamination such as skin oil or moisture causes erratic keyboard operation and multiple switches will turn on even though one switch is touched. By operating at a high frequency such as 100 kHz or 800 kHz, the impedance of the series combination of body and glass capacitance are lowered as compared to the impedance of contamination present on the glass thereby reducing crosstalk.

If glass thickness is smaller than $\frac{1}{16}$ inch, the touch circuit becomes more sensitive to body capacitance. There are two ways to adjust the sensitivity so that crosstalk does not occur: remove diode 414 and/or reduce the resistance of resistor 416. Increasing the resistance of resistor 416 would allow usage of thicker glass. However, this resistance preferably should not go above 750 k Ω . This is because of the maximum low input voltage of 0.8 V and input leakage current of 1 μ A at the Schmitt trigger gate 420.

The oscillator circuitry shown in FIG. 6 is very stable over the temperature range of -40° C. to 105° C. The output of the touch switch circuitry drops at a rate of approximately 40 mV/ $^{\circ}$ C. when temperature falls below 0° C. If application requires operation at low temperatures (-40° C.), the following three methods may be used to increase the output of the switch: increase the oscillator's regulated supply voltage, increase the resistance of resistor 416, and use a higher gain transistor 410. All of these methods would increase sensitivity at high temperatures. Another way to correct this problem is to use a thermistor to vary the regulated supply voltage as a function of temperature.

Since the input power is regulated down to 26 V DC, variation of power (24 V AC \pm 10% or 29 V DC to 36 V DC) does not affect circuit operation. Table 3 below shows the measured output voltage of the switch for various supply voltages.

TABLE 3

SUPPLY VOLTAGE	SWITCH OUTPUT
36 VDC	4.96 V
35 VDC	4.96 V
34 VDC	4.95 V
33 VDC	4.95 V
32 VDC	4.94 V
31 VDC	4.93 V
30 VDC	4.93 V
29 VDC	4.92 V

$$PSRR=6 \text{ mV/V}=-45 \text{ dB}$$

In order to determine the effect of body capacitance on circuit operation, the circuit of FIG. 3 was used to simulate glass, water resistance, and body capacitance. The following two conditions were simulated and tested:

- 1—The maximum body capacitance that does not cause crosstalk when:
 Temperature=105° C.
 Supply Voltage=36VDC
 Glass Capacitance=2 pF
 Water Resistance=330 k to 1 MΩ
 - 2—The minimum capacitance to turn on a switch when:
 Temperature=0° C.
 Supply Voltage=29VDC
 Glass Capacitance=2 pF
 - 3—Operation at room temperature.
- Table 4 below shows the signal and noise voltages at the switch output for different values of body capacitance and contamination resistance.

TABLE 4

CONTAMINATION RE-SISTANCE	BODY CAPACITANCE				
	20 pF	220 pF	330 pF	550 pF	1230 pF
330 kΩ	S: 5.1 V	S: 5.1 V	S: 5.1 V	S: 5.1 V	S: 5.1 V
	N: 2.0 V	N: 4.0 V	N: 4.5 V	N: 4.9 V	N: 5.0 V
500 kΩ	S: 5.1 V	S: 5.1 V	S: 5.1 V	S: 5.1 V	S: 5.1 V
	N: 0.2 V	N: 0.6 V	N: 0.7 V	N: 0.8 V	N: 0.8 V
1 MΩ (Condensed Water)	S: 5.1 V	S: 5.1 V	S: 5.1 V	S: 5.1 V	S: 5.1 V
	N: 0.1 V	N: 0.1 V	N: 0.1 V	N: 0.1 V	N: 0.1 V
NONE	S: 5.1 V	S: 5.1 V	S: 5.1 V	S: 5.1 V	S: 5.1 V
	N: 10 mV	N: 10 mV	N: 10 mV	N: 10 mV	N: 10 mV

S = Signal (TOUCH)
 N = Noise (NO TOUCH)
 supply voltage = 36 VDC
 temperature = 105° C.

With contamination resistance of 1 MΩ or more, the circuit is insensitive to body capacitance variations and has a minimum signal-to-noise ratio of -34 dB. With no contamination, signal-to-noise ratio is approximately -54 dB. The graph in FIG. 9 shows the signal-to-noise ratio versus body capacitance, for different values of contamination resistance at 105° C. The minimum body capacitance to turn on a switch is 20 pF.

At room temperature, crosstalk decreases because of gain drop of transistor 410. Table 5 below shows that at room temperature, the circuit rejects 250 kΩ of contamination, independent of body capacitance. Below 250 kΩ, body capacitance will affect crosstalk.

TABLE 5

CONTAMINATION RE-SISTANCE	BODY CAPACITANCE				
	20 pF	220 pF	330 pF	550 pF	1230 pF
200 kΩ	S: 5.1 V	S: 5.1 V	S: 5.1 V	S: 5.1 V	S: 5.1 V
	N: 0.2 V	N: 1.0 V	N: 1.2 V	N: 1.8 V	N: 2.2 V
250 kΩ	S: 5.1 V	S: 5.1 V	S: 5.1 V	S: 5.1 V	S: 5.1 V
	N: 0.1 V	N: 0.1 V	N: 0.5 V	N: 0.5 V	N: 0.5 V
330 kΩ	S: 5.1 V	S: 5.1 V	S: 5.1 V	S: 5.1 V	S: 5.1 V
	N: 0.1 V	N: 0.1 V	N: 0.1 V	N: 0.1 V	N: 0.1 V
1 MΩ (Condensed Water)	S: 5.1 V	S: 5.1 V	S: 5.1 V	S: 5.1 V	S: 5.1 V
	N: 0.1 V	N: 0.1 V	N: 0.1 V	N: 0.1 V	N: 0.1 V

S = Signal (TOUCH)
 N = Noise (NO TOUCH)
 supply voltage = 36 VDC
 temperature = 25° C.

The graph of FIG. 10 shows the measured signal-to-noise ratio versus body capacitance, for different contamination resistance values at room temperature.

The particular advantages of the preceding circuit over that of existing touch detection circuits such as that disclosed in U.S. Pat. No. 4,758,735, are the use of diode 414 (selected for high speed) to minimize forward recovery time rather than merely provide reverse polarity protection (as with the slower type of diode used in the existing circuits) and the omission of a capacitor coupled across the base to emitter junction of the detection transistor 410 to make the circuit more sensitive and operable with a lower oscillator amplitude and higher oscillator frequency. These features along with appropriate choices in component values make possible operation at significantly higher frequencies (>50 to 800 kHz) than are seen in existing art (60 to 1000 Hz). At frequencies at or near 800 kHz, the 20-300 pF of capacitance to ground offered by the human body presents a considerably lower impedance than the primarily resistive impedance of skin oil or water films that may appear on the dielectric layer overlying the conductive touch pads. This allows the peak voltage of a pad that is touched to come considerably closer to ground than adjacent pads which will have a voltage drop across any contaminating film layer that is providing a conductive path to the area that is touched. The enhanced sensitivity offered by the omission of any capacitor between the base and emitter of the detection transistor 410, allows the threshold of detection to be set much closer to ground than would be the case otherwise. This allows discrimination between the pad that is touched and adjacent pads that might be pulled towards ground via the conductive path to the touch formed by a contaminating film. This high frequency regime of operation offers a considerable advantage relative to the existing art in terms of immunity to surface contaminants such as skin oil and moisture.

A multiple touch pad circuit constructed in accordance with the second embodiment is shown in FIG. 11. In the second embodiment of FIG. 11, components similar to those in the first embodiment in FIG. 4 are designated with the same references numerals and will not be discussed in detail. The multiple touch pad circuit is a variation of the first embodiment in that it includes an array of touch circuits designated as 900₁ through 900_{nm}, which, as shown, include both the touch circuit 400 shown in FIGS. 4 and 8 and the input touch terminal pad 451 (FIG. 4). Microcontroller 500 selects each row of the touch circuits 900₁ to 900_{nm} by providing the signal from oscillator 200 to selected rows of touch circuits. In this manner, microcontroller 500 can sequentially activate the touch circuit rows and associate the received inputs from the columns of the array with the activated touch circuit(s). To keep the path length 451 between the touch pad 450 and the base to the detection transistor 410 to a minimum, the detection circuits 900 are physically located directly beneath the touch pads. To simplify assembly, a flexible circuit board such as vended by Sheldahl, Inc. or Circuit Etching Technics, Inc. can be used for this purpose. Ideally, the printed circuit will be fixed directly against the surface (typically glass) bearing the conductive touch pads to eliminate air gaps and the need for conductive foam pads and spring contacts which were used to fill air gaps.

For this second embodiment, the oscillator 200 of the first embodiment may be slightly modified from that shown in FIG. 6 to include a transistor (not shown) coupled between the oscillator output and ground with it's base connected to microcontroller 600 such that microcontroller 600 may selectively disable the output of oscillator 200.

The use of a high frequency in accordance with the present invention provides distinct advantages for circuits

such as the multiple touch pad circuit of the present invention due to the manner in which crosstalk is substantially reduced without requiring any physical structure to isolate the touch terminals. Further, the reduction in crosstalk afforded by the present invention, allows the touch terminals in the array to be more closely spaced together.

A third embodiment of the present invention, which provides touch circuit redundancy, is described below with reference to FIGS. 12-14. As shown in FIG. 12, the switching circuit according to the third embodiment includes a voltage regulator 1100 for regulating power supplied by 24 V DC power lines 1101 and 1102 with ground connection 1103, for supplying the regulated power to an oscillator 1200 via lines 1104 and 1107.

Oscillator 1200 supplies a continuous and periodic signal to touch circuits 1400a and 1400b via line 1201. Preferably, the frequency of the oscillator output signal is at least 100 kHz, and more preferably, at least 800 kHz. The two touch circuits 1400a and 1400b are identical in construction and both receive the output of touch terminal 1450 via line 1451. A detailed description of the preferred voltage regulator circuit 1100, oscillator 1200, and touch circuits 1400a and 1400b is provided below with reference to FIG. 13 following the description of the remaining portion of the third embodiment.

The output of the first touch circuit 1400a is supplied to a first driver circuit 1500 via line 1401a while the output of the second touch circuit 1400b is supplied to a second driver circuit 1600 via line 1401b. The two driver circuits 1500 and 1600 are provided to drive first and second serially connected switching transistors 1700 and 1710. The switching transistors 1700 and 1710 must both be conducting to supply power to a relay switch 1800. Thus, if one of touch circuits 1400a and 1400b does not detect a touch of touch terminal 1450, one of switching transistors 1700 and 1710 will not conduct and power will not be supplied to relay switch 1800. The preferred construction of driver circuits 1500 and 1600 and relay switch 1800 are described below with reference to FIG. 14.

As shown in FIG. 13, voltage regulator 1100 may be constructed by providing a first capacitor 1110 and a varistor 1112 connected in parallel across input power terminals 1101 and 1102. Preferably, return power terminal 1102 is connected via line 1103 to ground. Varistor 1112 is used to protect the circuit for over-voltage conditions. Also connected in parallel with first capacitor 1110 and varistor 1112, are the serially connected combination of a fuse 1114, a diode 1116, a resistor 1118 and two parallel connected capacitors 1120 and 1122. The voltage regulator 1100 is reverse polarity protected by diode 1116 and current limited by resistor 1118. Capacitors 1120 and 1122 provide filtering.

Voltage regulator 1100 further includes a zener diode 1128 having its cathode connected to a node between resistor 1118 and capacitors 1120 and 1122 and to output power line 1104. The anode of zener diode 1128 is coupled to output power common line 1107 and to ground line 1103 via two serially connected resistors 1124 and 1126. Zener diode 1128 and resistors 1124 and 1126 generate regulated 15 V DC. Two capacitors 1130 and 1132 are connected in parallel with zener diode 1128 between power lines 1104 and 1107. Capacitors 1130 and 1132 provide filtering and decoupling, respectively. Preferably, capacitor 1110 has a capacitance of 1000 pF, 1000V, varistor 1112 is part no. S14K25 available from Siemens, fuse 1114 is a ¼A fuse, diode 1116 is part no. 1N4002 available from LITEON, resistor 1118 has a resistance of 10Ω, ½W, capacitor 1120 has a capacitance of 22 μF, 35V, capacitor 1122 has a

capacitance of 0.1 μF, zener diode 1128 is part no. 1N4744A available from LITEON, resistor 1124 has a resistance of 220Ω, resistor 1126 has a resistance of 220Ω, capacitor 1130 has a capacitance of 1 μF, 25V, and capacitor 1132 has a capacitance of 0.1 μF.

Oscillator 1200 is preferably comprised of a first inverter gate 1210 having its input coupled to its output via resistors 1214 and 1216, and a second inverter gate 1212 having its input coupled to the output of first inverter gate 1210 and its output coupled to its input via a capacitor 1218 and resistor 1216. The oscillating output of the second inverter gate 1212 is buffered via transistor 1226, which has its base connected to the output of second inverter gate 1212 via resistor 1220 and capacitor 1222, which are connected in parallel therebetween. The base of transistor 1226 is also coupled to power line 1104 via a resistor 1224. The emitter of transistor 1226 is connected to power line 1104 and the collector is connected to power line 1107 via a resistor 1230, to the anode of a diode 1228, and to the oscillator output line 1201. Diode 1228 has its cathode connected to power line 1104 and is used to protect transistor 1226.

Preferably, inverter gates 1210 and 1212 are provided by part no. CD40106B available from Harris, resistor 1214 has a resistance of 10 kΩ, resistor 1216 has a resistance of 1.18 kΩ, 1%, capacitor 1218 has a capacitance of 220 pF, resistor 1220 has a resistance of 4.7 kΩ, capacitor 1222 has a capacitance of 220 pF, resistor 1224 has a resistance of 100 kΩ, transistor 1226 is part no. MMBTA70L available from Motorola, diode 1228 is part no. RLS4448 available from LITEON, and resistor 1230 has a resistance of 3.3 kΩ.

Two touch circuits 1400a and 1400b are provided in parallel to provide redundancy so that if one fails, the relay drivers are disabled. Because the touch circuits 1400a and 1400b are identical, only one of the touch circuits will now be described. Touch circuit 1400a preferably includes two resistors 1410a and 1412a coupled in series between touch terminal output line 1451 and the base of a bipolar PNP transistor 1420a. Transistor 1420a has its emitter connected to the oscillator output line 1201 and its collector connected to power common line 1107 via a resistor 1422a. Touch circuit 1400a further includes a diode 1414a, a capacitor 1416a, and a resistor 1418a all connected in parallel between the base of transistor 1420a and the emitter thereof, which is connected to oscillator output line 1201. Touch circuit 1400a also includes a diode 1424a having its anode connected to the collector of transistor 1420a and its cathode connected to touch circuit output line 1401a via a resistor 1426a.

Preferably, resistor 1410a has a resistance of 5.1 kΩ, resistor 1412a has a resistance of 5.1 kΩ, diode 1414a is part no. RLS4448 available from LITEON, capacitor 1416a has a capacitance of 240 pF, resistor 1418a has a resistance of 12 MΩ, transistor 1420a is part no. BC857CL available from Motorola, resistor 1422a has a resistance of 100 kΩ, diode 1424a is part no. RLS4448 available from LITEON, and resistor 1426a has a resistance of 100 kΩ.

The preferred detailed construction of the first and second driver circuits 1500 and 1600 will now be described with reference to FIG. 14. In first driver circuit 1500, the output line 1401a of first touch circuit 1400a is connected to power common line 1107 via a resistor 1510 and also via a capacitor 1512 connected in parallel therewith. The output line 1401a is also connected to the inverting input terminal of an operational amplifier 1514. The non-inverting input terminal of operational amplifier 1514 is connected to line 1502, which runs between first and second driver circuits

1500 and 1600 and is connected to power line 1104 via a resistor 1626. The output of op amp 1514 is connected to power line 1104 via a resistor 1518 and to the input of a Schmitt trigger inverter gate 1516. The output of Schmitt trigger inverter gate 1516 is connected to the input of a second Schmitt trigger inverter gate 1526 via a resistor 1520. A diode 1522 is connected in parallel with resistor 1520 with its cathode connected to the output of inverter gate 1516 and its anode connected to the input of inverter gate 1526 and to power common line 1107 via capacitor 1524. The output of inverter gate 1526 is connected to the base of bipolar PNP switching transistor 1700 via a resistor 1528. The base of transistor 1700 is also connected to power common line 1107 via a capacitor 1532 and to power line 1104 and its emitter via a resistor 1530.

Preferably, resistor 1510 has a resistance of 10 M Ω , capacitor 1512 has a capacitance of 0.01 μ F, op amp comparator 1514 is part no. LM393 available from National Semiconductor, inverter gate 1516 is part no. CD40106B available from Harris, resistor 1518 has a resistance of 10 k Ω , resistor 1520 has a resistance of 1 M Ω , diode 1522 is part no. RLS4448 available from LITEON, capacitor 1524 has a capacitance of 0.22 μ F, inverter gate 1526 is part no. CD40106 available from Harris, resistor 1528 has a resistance of 12 k Ω , resistor 1530 has a resistance of 100 k Ω , capacitor 1532 has a capacitance of 0.01 μ F, and transistor 1700 is part no. MMBTA56L available from Motorola.

In second driver circuit 1600, the output line 1401b of second touch circuit 1400b is connected to power common line 1107 via a resistor 1610 and also via a capacitor 1612 connected in parallel therewith. The output line 1401b is also connected to the inverting input terminal of an operational amplifier 1614. The non-inverting input terminal of operational amplifier 1614 is connected to line 1502, which is connected to power line 1104 via resistor 1626. The non-inverting input terminal of op amp 1614 is also connected to power common line 1107 via a capacitor 1616 and a resistor 1618, which are connected in parallel. The output of op amp 1614 is connected to power line 1104 via a resistor 1630 and to the coupled inputs of a Schmitt trigger inverter gate 1628. The output of op amp 1614 is also connected to its non-inverting input terminal via a resistor 1624. The output of Schmitt trigger inverter NAND gate 1628 is connected to the input of a second Schmitt trigger inverter gate 1638 via a resistor 1632. A diode 1634 is connected in parallel with resistor 1632 with its cathode connected to the output of inverter NAND gate 1628 and its anode connected to the input of inverter NAND gate 1638 and to power common line 1107 via a capacitor 1636. The output of inverter gate 1638 is connected to the base of switching bipolar PNP transistor 1710 via a resistor 1640. The base of transistor 1710 is also connected to power common line 1107 via a capacitor 1642 and to power line 1104 via a resistor 1644. Second driver circuit 1600 also preferably includes capacitors 1620 and 1622 connected in parallel between its connections to power lines 1104 and 1107.

Preferably, resistor 1610 has a resistance of 10 M Ω , capacitor 1612 has a capacitance of 0.01 μ F, op amp comparator 1614 is part no. LM393 available from National Semiconductor, capacitor 1616 has a capacitance of 0.01 μ F, resistor 1618 has a resistance of 20 k Ω , capacitor 1620 has a capacitance of 0.1 μ F, capacitor 1622 has a capacitance of 0.1 μ F, resistor 1624 has a resistance of 100 k Ω , resistor 1626 has a resistance of 10 k Ω , inverter NAND gate 1628 is part no. CD4093B available from Harris, resistor 1630 has a resistance of 10 k Ω , resistor 1632 has a resistance of 1 M Ω , diode 1634 is part no. RLS4448 available from

LITEON, capacitor 1636 has a capacitance of 0.22 μ F, inverter NAND gate 1638 is part no. CD4093B available from Harris, resistor 1640 has a resistance of 12 k Ω , capacitor 1642 has a capacitance of 0.01 μ F, resistor 1644 has a resistance of 100 k Ω , and transistor 1710 is part no. MMBTA56L available from Motorola.

In operation, the output of transistor 1420a (FIG. 13) taken at its collector is rectified by diode 1424a and a DC level is generated by resistors 1426a and 1510 and capacitor 1512 (a DC level of the output of transistor 1420b is generated by resistors 1426b and 1610 and capacitor 1612). When this DC level exceeds the upper threshold voltage of op amp comparator 1514 (1614), the output of schmitt triggered inverter gate 1516 inverter NAND gate 1628 (1628) goes high which charges capacitor 1524 (1636) through resistor 1520 (1632). Gates 1516 and 1526 (1628 and 1638), resistor 1520 (1632), and capacitor 1524 (1636) provide debounce in a conventional manner. Diode 1522 (1634) is used to provide fast release when the palm of the hand is removed from the touch terminal 1450. The output of the debounce circuitry drives transistor 1700 (1710). Resistor 1528 (1640) and capacitor 1532 (1642) are used to filter noise. Both touch circuits must be functional in order to drive the relay switch 1800. Also, if one of the transistors 1700 or 1710 fails, the relay will not be activated.

Relay switch 1800 may be any conventional relay. An example of such a relay is shown in FIG. 14. Relay switch 1800 may include a relay coil 1810 coupled between the selective power supply 1711 of transistors 1700 and 1710 and ground, and a pair of magnetically responsive switches that switch from normally closed terminals 1805 and 1807 to normally open terminals 1801 and 1803 when the relay coil is energized. A zener diode 1815 may be placed in series with a diode 1820 to reduce stress on the relay coil 1810 and to protect transistor 1710 when transistors 1700 and 1710 switch off.

Although the touch circuits of the third embodiment are disclosed as operating a relay switch via driver circuits, it will be appreciated by those skilled in the art that the outputs of touch circuits 1400a and 1400b could be supplied to a microcontroller in the manner discussed above with respect to the first embodiment.

The palm button switch of the present invention uses two redundant touch switch circuits, such as shown in FIG. 12, to disable relay drivers if one of the touch switch circuits fails and redundant relay driver circuitry to turn off a relay switch if one of the driver circuits fails.

Alternatively, the circuitry shown in FIG. 4 could be used. In another embodiment a method to prevent inadvertent actuations is to require a multi-step process. Referring to FIG. 19, a device is shown having a first palm button 2201, a second palm button 2202, and an indicator light 2205. Palm button 2201 has to be activated first and then button 2202 has to be activated within a 2 second time window before a desired actuation can occur. The 90 degree orientation of the two buttons makes it extremely difficult to accidentally touch both with an arm and an elbow or other such physical combination. An added advantage is that the motion required to move the hand from button 2201 to button 2202 can provide some relief from fatigue in the forearm by the resulting muscle flexure that would otherwise not occur if the hand had to be kept near a single button for extended periods of time. A further redundancy can be achieved by requiring simultaneous operation of two such devices, one for each hand. This provides further safeguards against inadvertent actuations and forces the operator to have both hands in a desired safe location once a desired

actuation occurs. A further option is to provide one or more LEDs 2205 or audible annunciators for visual or audible feedback to the operator. Specifically, in FIG. 19 the LED 2205 will come on when button 2201 has been successfully activated to cue the operator that it is time to move to button 2202. Where required a second LED with a different color than the first (yellow for the first LED and red for the second) can be provided to provide visual confirmation that the second button 2202 has been activated or that the required combination of the two buttons has been activated. Two different audible tone or sound generators could also be used in lieu of the LEDs to provide feedback to the operator. In industrial or other challenging settings, the housing is made of high strength polycarbonate (or other high strength non-metallic material) to meet high impact and vibration requirements, preferably NEMA 4. A further option is to provide lighting for the switches to allow operation in the dark.

In a variation of the multi-step process, two touch plates within a housing (one vertical and one horizontal) are used to provide a two-step turn-on. Referring to FIGS. 20A-C, the first step to actuate the output relay 2310, is initiated when the operator inserts his hands and touches the vertical touch sensor 2301 with the dorsal side of the hands. A yellow LED 2304 on top of the device show the successful completion of the first step. The second step is to flip the hand over and touch the horizontal touch sensor 2302 with the palmar side of the hand. A red LED 2305 on top of the device shows the completion of the two step turn-on and activation of output relay 2310. The flipping action of the hand in the second step causes the forearm muscles to flex, thereby reducing stiffness and fatigue. Also, the hands, and arms can rest on the run bar until the machine cycle is complete. The second step of the two-step turn-on must occur within some predetermined time (for example 2 seconds) after the release of vertical touch sensor or the first step must be repeated. In this proposed embodiment, the second step provides an added stimulus and reduces operator errors due to mental and physical fatigue. The top cover prevents actuation of two devices by the use of one hand and elbow of the same arm, as required by ANSI Standard B11.19-1990. The enclosure must be a high strength polycarbonate module to meet the high impact and vibration requirements of the industry, preferably NEMA 4. In both embodiments, high frequency switching is used to desensitize the unit against moisture and contaminants that could generate a path between the button and grounded chassis. The palm button may be formed as the flat palm button shown in FIGS. 15A-C or as a dome-shaped palm button shown in FIG. 16. The button is made of a brass plate 1910 (1930) and can be covered with a plastic or glass 1925 (1933) cover or membrane to desensitize the unit even more against contaminants and other inadvertent actuation. The plastic cover 1925 (1933) acts as a dielectric and capacitance is varied as a function of the area of the plastic being touched. Therefore, if button is touched by finger, a much smaller series capacitance is generated as opposed to button being touched by the palm of a hand. This capacitance is placed in series with the capacitance of the body to ground when the button is touched. Since the capacitance of the body to ground is much larger than the capacitance generated by the button, the functionality of the unit is independent of the variations in body capacitance to ground from person to person. The other factor that needs to be considered here is body resistance. If the button is not covered with an insulator such as plastic, the unit would become sensitive to body resistance. Body resistance to ground, changes as a function of moisture in the work area,

skin dryness, floor structure, and shoes. By using a plastic cover, the unit is made insensitive to variations of body resistance and capacitance. The shape of the button is also a factor in sensitivity. If the button is flat, less of the button area would be covered by the palm of the hand as opposed to a dome shape button that matches the contour of the palm. Therefore, if the button is dome-shaped, the unit can be even more desensitized against inadvertent operation.

By providing a large space for hand insertion and switch activation and a flat or dome shape button where the palm of the hand rests while machine cycle is in process, stress on the forearms is ergonomically reduced. The palm button of the present invention can be activated with or without gloves. The zero force palm button of the present invention may be used to activate electric, pneumatic, air clutch, and hydraulic equipment such as punch presses, molding machines, etc.

As shown in FIGS. 15A-C, the flat palm button may include a plastic housing 1917 having an optional metallic enclosure 1922 for surface mounting. The button also may include a flush mount surface 1915 and optional guarding 1920.

The circuit board 1935 used with the palm button of the present invention may be packaged on two printed circuit boards. One board for power and relay and the other for touch switches and relay drivers. The touch circuit on the touch switch board is interfaced to the button through a screw that also holds the button in place. The power/relay board is interfaced to the touch switch board through a three pin right angle connector. Wiring to the unit is done through a seven position terminal block on the power/relay board. The power/relay board is designed for 24 V DC input power and provides two double-throw relay contacts. However, it can be modified to accommodate different power inputs and switch outputs. For example, a transformer may be added to the power board so that the unit is powered 110VAC/220VAC instead of 24 V DC. Also, the relays may be replaced with other outputs such as digital or 4-20 mA outputs.

The touch circuit components can be integrated in a custom IC 2000, as shown in FIG. 17, to facilitate manufacturing and to reduce cost. Components 413, 412, 414, 410, 418, and 420 are similar to those of circuit 400 shown in FIG. 8. Preferably, resistor 2004 has a resistance of 470 k Ω and diode 2002 has characteristics similar to part no. 1N4148 available from LITEON. Resistors 2008 and 2006 are used to adjust the sensitivity. Diode 2002 at the output of 420, allows the IC to be used in applications where several touch circuit IC's are multiplexed.

As shown in FIG. 18, a sleep circuit 2100 may be added to the oscillator circuit 200 (FIG. 6) to allow microcontroller 600 to turn off the oscillator circuit 200. The disabling of oscillator circuit 200 is done to reduce drainage of capacitor 126 in the regulator circuit 120 during brown outs. The circuit diagram shown in FIG. 18 is a modified version of circuit 200 in FIG. 6. During normal operation microcontroller 600 pulls the input of gate 2116 to ground and causes the output of gate 2116 to go high (power line 104). Therefore, transistor 2110 is biased on and oscillator 200 is functional. When in a sleep mode, microcontroller 600 sources the input to gate 2116 high and causes the output of gate 2116 to go low which turns off transistor 2110 and pulls the input of gate 212 low. Therefore, the oscillator will stop oscillating and drainage on capacitor 126 decreases considerably.

The above described embodiments were chosen for purposes of describing but one application of the present

invention. It will be understood by those who practice the invention and by those skilled in the art, that various modifications and improvements may be made to the invention without departing from the spirit or scope of the invention as defined by the appended claims.

The embodiments of the invention in which an exclusive property or privilege is claimed are defined as follows:

1. A capacitive responsive electronic switching circuit comprising:

an oscillator providing a periodic output signal having a frequency of 50 kHz or greater;

an input touch terminal having a dielectric cover defining an area for an operator to provide an input by proximity and touch, an operator's body capacitance to ground as sensed through said input touch terminal varying as a function of the area of said input touch terminal that is proximate the operator's body; and

a detector circuit coupled to said oscillator for receiving said periodic output signal from said oscillator, and coupled to said input touch terminal, said detector circuit being responsive to signals from said oscillator and the presence of an operator's body capacitance to ground coupled to said touch terminal when proximal or touched by an operator to provide a control output signal, wherein said detector circuit includes means for generating said control signal when the sensed body capacitance to ground exceeds a threshold level in order to prevent unintended activation based upon an operator's inadvertent proximity and touch with said input touch terminal.

2. The switching circuit as defined in claim 1, wherein said oscillator provides a periodic output signal having a frequency of 800 kHz or greater.

3. The switching circuit as defined in claim 1 and further including a DC power supply for supplying power to said oscillator and a ground.

4. The switching circuit as defined in claim 1, wherein said periodic output signal provided by said oscillator is a square wave output signal, said oscillator includes a square wave generator for generating a square wave, and a plurality of active elements coupled to an output of said square wave generator to buffer and improve the shape of the square wave output therefrom.

5. The switching circuit as defined in claim 1, wherein said detector circuit includes a microcontroller and a charge pump circuit coupled between said input touch terminal and said microcontroller.

6. The switching circuit as defined in claim 1, wherein said detector circuit includes a microcontroller and a touch circuit coupled between said input touch terminal and said microcontroller.

7. The switching circuit as defined in claim 6 and further including a plurality of said input touch terminals and a plurality of said touch circuits respectively associated with said input touch terminals.

8. The switching circuit as defined in claim 7, wherein said microcontroller selectively applies said periodic output signals received from said oscillator to each of said touch circuits to separately activate each touch circuit.

9. A capacitive responsive electronic switching circuit comprising:

an oscillator providing a periodic output signal having a frequency of 50 kHz or greater;

an input touch terminal defining an area for an operator to provide an input by proximity and touch;

a detector circuit coupled to said oscillator for receiving said periodic output signal from said oscillator, and

coupled to said input touch terminal, said detector circuit being responsive to signals from said oscillator and the presence of an operator's body capacitance to ground coupled to said touch terminal when proximal or touched by an operator to provide a control output signal; and

a floating common generator coupled to said oscillator for receiving said square wave output signal, said floating common generator generating a floating common reference for said detector circuit that is set at a fixed voltage below and tracks the square wave output signal.

10. The switching circuit as defined in claim 9, wherein said detector circuit is powered by said square wave output signal provided by said oscillator and by said floating common reference provided by said floating common generator thereby increasing the sensitivity of said detector circuit to proximity and touching of said touch terminal by an operator's body.

11. The switching circuit as defined in claim 10, wherein said detector circuit includes a microcontroller and a charge pump circuit coupled between said input touch terminal and said microcontroller, by an operator's body, wherein said charge pump circuit includes at least one high speed diode coupled between said oscillator and said touch terminal, for enhancing a sensitivity at which said charge pump responds to sensed body capacitance at said touch terminal for higher frequencies.

12. A proximity and touch controlled switching circuit comprising:

an oscillator providing a square wave output signal having a frequency of 50 kHz or greater;

a touch terminal having a dielectric cover defining an input terminal for coupling to an operator's body capacitance to ground; and

a charge pump circuit coupled to said oscillator for receiving said square wave output signal, and coupled to said touch terminal, said charge pump circuit having an output terminal that supplies an output signal having a voltage that varies when said touch terminal is proximal or touched by an operator's body, the voltage of said output signal varies as a function of the area of said touch terminal that is proximal or touched by an operator.

wherein said charge pump circuit includes at least one high speed diode coupled between said oscillator and said touch terminal, for enhancing a sensitivity at which said charge pump responds to sensed body capacitance to ground at said touch terminal for higher frequencies.

13. The proximity and touch controlled circuit as defined in claim 12 and further including a DC power supply for supplying power to said oscillator and a ground.

14. The proximity and touch controlled circuit as defined in claim 12, wherein said oscillator includes a square wave generator for generating a square wave, and a plurality of active elements coupled to an output of said square wave generator to buffer and improve the shape of the square wave output therefrom.

15. The proximity and touch controlled circuit as defined in claim 12, wherein said oscillator provides a periodic output signal having a frequency of 800 kHz or greater.

16. A proximity and touch controlled switching circuit comprising:

an oscillator providing a square wave output signal having a frequency of 50 kHz or greater;

a touch terminal defining an input terminal for coupling to an operator's body capacitance to ground;

27

a charge pump circuit coupled to said oscillator for receiving said square wave output signal, and coupled to said touch terminal, said charge pump circuit having an output terminal that supplies an output signal having a voltage that varies when said touch terminal is proximal or touched by an operator's body; and

a floating common generator coupled to said oscillator for receiving said square wave output signal, said floating common generator generating a floating common reference for said charge pump circuit that is set at a fixed voltage below and tracks said square wave output signal.

wherein said charge pump circuit includes at least one high speed diode coupled between said oscillator and said touch terminal, for enhancing a sensitivity at which said charge pump responds to sensed body capacitance to ground at said touch terminal for higher frequencies.

17. The proximity and touch controlled circuit as defined in claim 16, wherein said charge pump circuit is powered by said square wave output signal provided by said oscillator and by said floating common reference provided by said floating common generator thereby increasing the sensitivity of said charge pump circuit to proximity and touching of said touch terminal by an operator's body.

18. A capacitive responsive electronic switching circuit comprising:

an oscillator providing a periodic output signal having a predefined frequency;

a plurality of input touch terminals defining adjacent areas on a dielectric substrate for an operator to provide inputs by proximity and touch; and

a detector circuit coupled to said oscillator for receiving said periodic output signal from said oscillator, and coupled to said input touch terminals, said detector circuit being responsive to signals from said oscillator and the presence of an operator's body capacitance to ground coupled said touch terminals when proximal or touched by an operator to provide a control output signal,

wherein said predefined frequency of said oscillator is selected to decrease the impedance of said dielectric substrate relative to the impedance of any contaminate that may create an electrical on said dielectric substrate path between said adjacent areas, and wherein said detector circuit compares the sensed body capacitance to ground proximate an input touch terminal to a threshold level to prevent inadvertent generation of the control output signal.

19. The switching circuit as defined in claim 18, wherein said oscillator provides a periodic output signal having a frequency of 800 kHz or greater.

20. A capacitive responsive electronic switching circuit comprising:

an oscillator providing a periodic output signal having a predefined frequency;

a dome-shaped touch terminal defining an area for an operator to provide an input by proximity and touch, wherein the dome shape of the touch terminal is constructed to ergonomically fit the palm of a human hand; and

a detector circuit coupled to said oscillator for receiving said periodic output signal from said oscillator, and coupled to said touch terminal, said detector circuit being responsive to signals from said oscillator and the presence of an operator's body capacitance to ground

28

coupled to said touch terminal when proximal or touched by an operator to provide a control output signal, said detector circuit including means for discriminating between a proximity and touch of said dome-shaped touch terminal by the palm of a human hand and a proximity and touch by a human finger.

21. A capacitive responsive electronic switching circuit comprising:

an oscillator providing a periodic output signal having a predefined frequency;

a touch terminal defining an area for an operator to provide an input by proximity and touch; and

a detector circuit coupled to said oscillator for receiving said periodic output signal from said oscillator, and coupled to said touch terminal, said detector circuit being responsive to signals from said oscillator and the presence of an operator's body capacitance to ground coupled to said touch terminal when proximal or touched by an operator to provide a control output signal, said detector circuit including discriminating means for discriminating between a proximity and touch of said touch terminal covering substantially all of said area of said touch terminal and a proximity and touch covering less than substantially all of said area of said touch terminal.

22. The switching circuit as defined in claim 21, wherein said touch terminal includes a dome-shaped dielectric cover.

23. The switching circuit as defined in claim 21, wherein said touch terminal includes a palm-sized dielectric cover.

24. The switching circuit as defined in claim 23, wherein said discriminating means determines that a proximity and touch of said touch terminal covers substantially all of said area of said touch terminal when said dielectric cover is proximal or touched with the palm of an operator's hand and determines that a proximity or touch covers less than substantially all of said area of said touch terminal when said dielectric cover is proximal or touched with one of an operator's fingers.

25. The switching circuit as defined in claim 21, wherein said discriminating means discriminates between a proximity and touch of said touch terminal covering substantially all of said area of said touch terminal and a proximity and touch covering less than substantially all of said area of said touch terminal based upon a sensed level of body capacitance to ground proximate said touch terminal.

26. The switching circuit as defined in claim 21, wherein said coupling of capacitance to ground occurs when an operator's body is proximate, but not touching, said touch terminal.

27. A capacitive responsive electronic switching circuit for a controlled device comprising:

an oscillator providing a periodic output signal having a predefined frequency;

first and second touch terminals defining areas for an operator to provide an input by proximity and touch; and

a detector circuit coupled to said oscillator for receiving said periodic output signal from said oscillator, and coupled to said first and second touch terminals, said detector circuit being responsive to signals from said oscillator and the presence of an operator's body capacitance to ground coupled to said first and second touch terminals when proximal or touched by an operator to provide a control output signal for actuation of the controlled device, said detector circuit being con-

29

figured to generate said control output signal when said an operator is proximal or touches said second touch terminal after the operator is proximal or touches said first touch terminal.

28. The capacitive responsive electronic switching circuit as defined in claim 27, wherein said detector circuit generates said control signal only when an operator is proximal or touches said second touch terminal within a predetermined time period after the operator is proximal or touches said first touch terminal.

29. The capacitive responsive electronic switching circuit as defined in claim 27, wherein said first and second touch terminals are adapted to be mounted on different surfaces of the controlled device.

30

30. The capacitive responsive electronic switching circuit as defined in claim 27, wherein said first and second touch terminals are adapted to be mounted on non-parallel planar surfaces of the controlled device.

31. The capacitive responsive electronic switching circuit as defined in claim 27, wherein said first and second touch terminals are adapted to be mounted on perpendicular planar surfaces of the controlled device.

32. The capacitive responsive electronic switching circuit as defined in claim 27 and further including an indicator for indicating when said detector circuit determines that an operator is proximal or touches said first touch terminal.

* * * * *

UNITED STATES PATENT AND TRADEMARK OFFICE
CERTIFICATE OF CORRECTION

PATENT NO. : 5,796,183
DATED : August 18, 1998
INVENTOR(S) : Byron Hourmand

Page 1 of 3

It is certified that error appears in the above-identified patent and that said Letters Patent is hereby corrected as shown below:

Column 5, line 52, "such a" should be --such as--.

Column 9, line 31, before "water" insert --condensed--.

Column 14, line 35, "is" should be --as--.

Column 13, line 65, "it's" should be --its--.

Column 18, line 38, "references" should be --reference--.

Column 20, line 7, "it's" should be --its-- (both occurrences).

Column 20, line 9, "it's" should be --its--.

Column 20, line 10, "it's" should be --its-- (both occurrences).

Column 20, line 13, "it's" should be --its--.

Column 20, line 20, "it's" should be --its--.

Column 20, line 39, "it's" should be --its--.

Column 20, line 40, "it's" should be --its--.

Column 20, line 46, "it's" should be --its--.

Column 20, line 47, "it's" should be --its--.

UNITED STATES PATENT AND TRADEMARK OFFICE
CERTIFICATE OF CORRECTION

PATENT NO. : 5,796,183
DATED : August 18, 1998
INVENTOR(S) : Byron Hourmand

Page 2 of 3

It is certified that error appears in the above-identified patent and that said Letters Patent is hereby corrected as shown below:

Column 21, line 8, "it's" should be --its--.

Column 21, line 9, "it's" should be --its--.

Column 21, line 15, "it's" should be --its--.

Column 21, line 42, "it's" should be --its--.

Column 21, line 46, "it's" should be --its--.

Column 21, line 47, "it's" should be --its--.

Column 21, line 56, "it's" should be --its--.

Column 22, line 8, "it's" should be --its--.

Column 22, line 13, "schmitt" should be --Schmitt--.

Column 26, lines 22-27, after "microcontroller." delete "by an operator's body . . . higher frequencies."

UNITED STATES PATENT AND TRADEMARK OFFICE
CERTIFICATE OF CORRECTION

PATENT NO. : 5,796,183
DATED : August 18, 1998
INVENTOR(S) : Byron Hourmand

Page 3 of 3

It is certified that error appears in the above-identified patent and that said Letters Patent is hereby corrected as shown below:

Column 27, line 44, after "electrical" insert "--path--".

Column 27, line 45, delete "path".

Column 29, line 1, after "when" delete "said".

Signed and Sealed this
Eleventh Day of May, 1999

Attest:



Q. TODD DICKINSON

Attesting Officer

Acting Commissioner of Patents and Trademarks

UNITED STATES PATENT AND TRADEMARK OFFICE
CERTIFICATE OF CORRECTION

PATENT NO. : 5,796,183
APPLICATION NO. : 08/601268
DATED : August 18, 1998
INVENTOR(S) : Byron Hourmand et al.

Page 1 of 1

It is certified that error appears in the above-identified patent and that said Letters Patent is hereby corrected as shown below:

Title Page, Item (75) Inventor, should read --(75) Inventors: Byron Hourmand,
Hersey, MI (US); John M. Washeleski, Cadillac, MI (US); Stephen R. W. Cooper,
Fowlerville, MI (US)--.

Signed and Sealed this
Eleventh Day of October, 2011

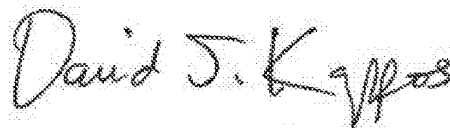

David J. Kappos
Director of the United States Patent and Trademark Office



US005796183C1

(12) **EX PARTE REEXAMINATION CERTIFICATE** (9614th)
United States Patent
Hourmand et al.

(10) **Number:** US 5,796,183 C1
(45) **Certificate Issued:** Apr. 29, 2013

- (54) **CAPACITIVE RESPONSIVE ELECTRONIC SWITCHING CIRCUIT**
- (75) Inventors: **Byron Hourmand**, Hersey, MI (US);
John M. Washeleski, Cadillac, MI (US);
Stephen R. W. Cooper, Fowlerville, MI (US)
- (73) Assignee: **Nartron Corporation**, Reed City, MI (US)

(58) **Field of Classification Search**
None
See application file for complete search history.

(56) **References Cited**

To view the complete listing of prior art documents cited during the proceeding for Reexamination Control Number 90/012,439, please refer to the USPTO's public Patent Application Information Retrieval (PAIR) system under the Display References tab.

Primary Examiner — Linh M. Nguyen

Reexamination Request:
No. 90/012,439, Aug. 17, 2012

Reexamination Certificate for:
Patent No.: 5,796,183
Issued: Aug. 18, 1998
Appl. No.: 08/601,268
Filed: Jan. 31, 1996

Certificate of Correction issued May 11, 1999
Certificate of Correction issued Oct. 11, 2011

(57) **ABSTRACT**

A capacitive responsive electronic switching circuit comprises an oscillator providing a periodic output signal having a frequency of 50 kHz or greater, an input touch terminal defining an area for an operator provide an input by proximity and touch, and a detector circuit coupled to the oscillator for receiving the periodic output signal from the oscillator, and coupled to the input touch terminal. The detector circuit being responsive to signals from the oscillator and the presence of an operator's body capacitance to ground coupled to the touch terminal when in proximity or touched by an operator to provide a control output signal. Preferably, the oscillator provides a periodic output signal having a frequency of 800 kHz or greater. An array of touch terminals may be provided in close proximity due to the reduction in crosstalk that may result from contaminants by utilizing an oscillator outputting a signal having a frequency of 50 kHz or greater.

- (51) **Int. Cl.**
H03K 17/96 (2006.01)
H03K 17/94 (2006.01)
- (52) **U.S. Cl.**
USPC 307/116; 307/125; 307/139; 361/181

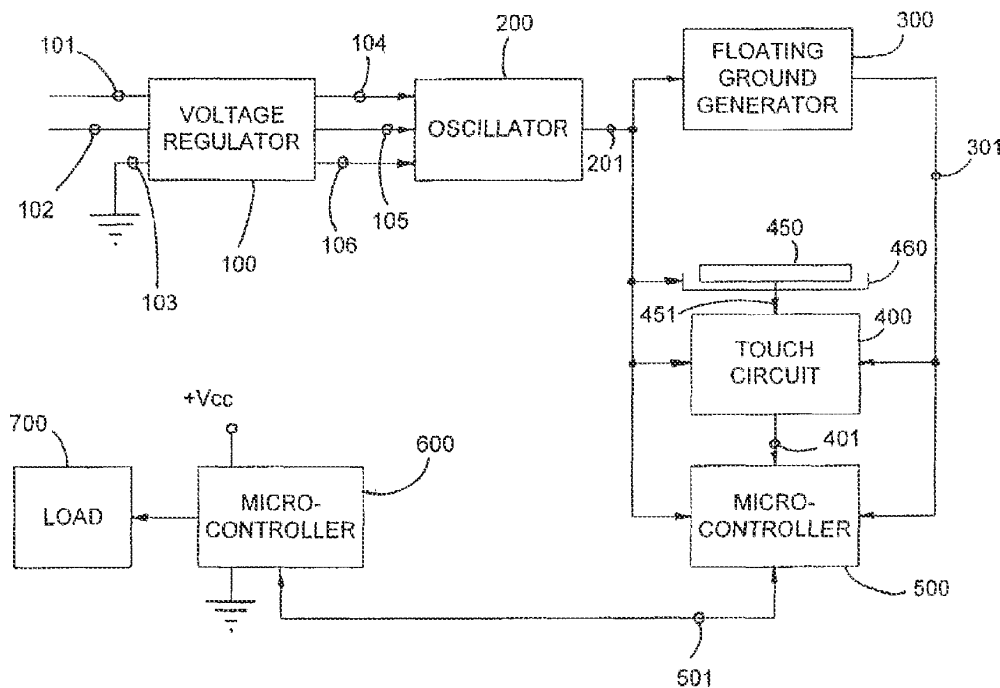

1
EX PARTE
REEXAMINATION CERTIFICATE
ISSUED UNDER 35 U.S.C. 307

THE PATENT IS HEREBY AMENDED AS
INDICATED BELOW.

Matter enclosed in heavy brackets [] appeared in the patent, but has been deleted and is no longer a part of the patent; matter printed in italics indicates additions made to the patent.

AS A RESULT OF REEXAMINATION, IT HAS BEEN DETERMINED THAT:

Claims 18, 27, 28 and 32 are determined to be patentable as amended.

New claims 33-39 are added and determined to be patentable.

Claims 1-17, 19-26 and 29-31 were not reexamined.

18. A capacitive responsive electronic switching circuit comprising:

an oscillator providing a periodic output signal having a predefined frequency;

a microcontroller using the periodic output signal from the oscillator, the microcontroller selectively providing signal output frequencies to a plurality of small sized input touch terminals of a keypad;

[a] the plurality of *small sized* input touch terminals defining adjacent areas on a dielectric substrate for an operator to provide inputs by proximity and touch; and a detector circuit coupled to said oscillator for receiving said periodic output signal from said oscillator, and coupled to said input touch terminals, said detector circuit being responsive to signals from said oscillator via said microcontroller and [the] a presence of an operator's body capacitance to ground coupled to said touch terminals when proximal or touched by [an] the operator to provide a control output signal,

wherein said predefined frequency of said oscillator [is] and said signal output frequencies are selected to decrease [the] a first impedance of said dielectric substrate relative to [the] a second impedance of any contaminant that may create an electrical path on said dielectric substrate between said adjacent areas *defined by the plurality of small sized input touch terminals*, and wherein said detector circuit compares [the] a sensed body capacitance change to ground proximate an input touch terminal to a threshold level to prevent inadvertent generation of the control output signal.

27. A capacitive responsive electronic switching circuit for a controlled keypad device comprising:

an oscillator providing a periodic output signal having a predefined frequency;

a microcontroller using the periodic output signal from the oscillator, the microcontroller selectively providing signal output frequencies to a closely spaced array of input touch terminals of a keypad, the input touch terminals comprising first and second input touch terminals;

the first and second input touch terminals defining areas for an operator to provide an input by proximity and touch; and

a detector circuit coupled to said oscillator for receiving said periodic output signal from said oscillator, and coupled to said first and second touch terminals, said

2

detector circuit being responsive to signals from said oscillator via said microcontroller and [the] a presence of an operator's body capacitance to ground coupled to said first and second touch terminals when proximal or touched by [an] the operator to provide a control output signal for actuation of the controlled keypad device, said detector circuit being configured to generate said control output signal when [an] the operator is proximal or touches said second touch terminal after the operator is proximal or touches said first touch terminal.

28. The capacitive responsive electronic switching circuit as defined in claim 27, wherein said detector circuit generates said control signal only when [an] the operator is proximal or touches said second touch terminal within a predetermined time period after the operator is proximal or touches said first touch terminal.

32. The capacitive responsive electronic switching circuit as defined in claim 27 and further including an indicator for indicating when said detector circuit determines that [an] the operator is proximal or touches said first touch terminal.

33. *The capacitive responsive electronic switching circuit as defined in claim 18, further comprising wherein said detector circuit compares the sensed body capacitance change caused by the body capacitance decreasing an input touch terminal signal on the detector to ground when proximate to the input touch terminal to a second threshold level to generate the control output signal.*

34. *The capacitive responsive electronic switching circuit as defined in claim 18, further comprising wherein said detector circuit compares the sensed body capacitance change caused by the body capacitance decreasing an input touch terminal signal amplitude on the detector to ground when proximate to the input touch terminal to a second threshold level to generate the control output signal.*

35. *The capacitive responsive electronic switching circuit as defined in claim 27, wherein when the second touch terminal is not touched on its defining area by the operator to provide input, the control output signal is prevented.*

36. *The capacitive responsive electronic switching circuit as defined in claim 27 and further including an indicator for indicating when said detector circuit determines that the operator is proximal or touches said second touch terminal.*

37. *A capacitive responsive electronic switching circuit for a controlled device comprising:*

an oscillator providing a periodic output signal having a predefined frequency, wherein an oscillator voltage is greater than a supply voltage;

a microcontroller using the periodic output signal from the oscillator, the microcontroller selectively providing signal output frequencies to a closely spaced array of input touch terminals of a keypad, the input touch terminals comprising first and second input touch terminals;

the first and second touch terminals defining areas for an operator to provide an input by proximity and touch; and a detector circuit coupled to said oscillator for receiving said periodic output signal from said oscillator, and

coupled to said first and second touch terminals, said detector circuit being responsive to signals from said oscillator via said microcontroller and a presence of an operator's body capacitance to ground coupled to said first and second touch terminals when proximal or touched by the operator to provide a control output signal for actuation of the controlled device, said detector circuit being configured to generate said control output signal when the operator is proximal or touches said second touch terminal after the operator is proximal or touches said first touch terminal.

38. The capacitive responsive electronic switching circuit as defined in claim 37, wherein feedback to the operator is provided by an indicator activated by the microcontroller after the operator touches the second touch terminal.

39. The capacitive responsive electronic switching circuit as defined in claim 37,

wherein said detector circuit compares a sensed body capacitance change caused by the body capacitance decreasing a second touch terminal signal on the detector to ground when proximate to the second touch terminal to a threshold level to generate the control output signal, and

wherein feedback to the operator is provided by an indicator activated by the microcontroller after the operator touches the second touch terminal.

* * * * *

EXHIBIT B



**UNITED STATES DEPARTMENT OF COMMERCE
Patent and Trademark Office**

Address: COMMISSIONER OF PATENTS AND TRADEMARKS
Washington, D.C. 20231

APPLICATION NO.	FILING DATE	FIRST NAMED INVENTOR	ATTORNEY DOCKET NO.
08/601,268	01/31/96	HOURMAND	B NAR01-P-310

21M1/0422

PRICE HENEVELD COOPER
DEWITT & LITTON
695 KENMOOR DRIVE SE
P O BOX 2567
GRAND RAPIDS MI 49501

EXAMINER

KAPLAN, J

ART UNIT PAPER NUMBER

2107

8

DATE MAILED: 04/22/97

Please find below and/or attached an Office communication concerning this application or proceeding.

Commissioner of Patents and Trademarks

Office Action Summary

Application No. 08/601,268	Applicant(s) Hourmand
Examiner Jonathan S. Kaplan	Group Art Unit 2107



- Responsive to communication(s) filed on _____
- This action is **FINAL**.
- Since this application is in condition for allowance except for formal matters, **prosecution as to the merits is closed** in accordance with the practice under *Ex parte Quayle*, 1935 C.D. 11; 453 O.G. 213.

A shortened statutory period for response to this action is set to expire three month(s), or thirty days, whichever is longer, from the mailing date of this communication. Failure to respond within the period for response will cause the application to become abandoned. (35 U.S.C. § 133). Extensions of time may be obtained under the provisions of 37 CFR 1.136(a).

Disposition of Claims

- Claim(s) 1-20 is/are pending in the application.
Of the above, claim(s) _____ is/are withdrawn from consideration.
- Claim(s) _____ is/are allowed.
- Claim(s) 1-4, 6-14, and 16-20 is/are rejected.
- Claim(s) 5 and 15 is/are objected to.
- Claims _____ are subject to restriction or election requirement.

Application Papers

- See the attached Notice of Draftsperson's Patent Drawing Review, PTO-948.
- The drawing(s) filed on _____ is/are objected to by the Examiner.
- The proposed drawing correction, filed on _____ is approved disapproved.
- The specification is objected to by the Examiner.
- The oath or declaration is objected to by the Examiner.

Priority under 35 U.S.C. § 119

- Acknowledgement is made of a claim for foreign priority under 35 U.S.C. § 119(a)-(d).
 - All Some* None of the CERTIFIED copies of the priority documents have been
 - received.
 - received in Application No. (Series Code/Serial Number) _____
 - received in this national stage application from the International Bureau (PCT Rule 17.2(a)).
- *Certified copies not received: _____
- Acknowledgement is made of a claim for domestic priority under 35 U.S.C. § 119(e).

Attachment(s)

- Notice of References Cited, PTO-892
- Information Disclosure Statement(s), PTO-1449, Paper No(s). 5 and 6
- Interview Summary, PTO-413
- Notice of Draftsperson's Patent Drawing Review, PTO-948
- Notice of Informal Patent Application, PTO-152

--- SEE OFFICE ACTION ON THE FOLLOWING PAGES ---

Art Unit: 2107

DETAILED ACTION

Claim Rejections - 35 USC § 112

1. Claims 6, 7, and 16 are rejected under 35 U.S.C. 112, second paragraph, as being indefinite for failing to particularly point out and distinctly claim the subject matter which applicant regards as the invention.

Claims 6 and 16 are vague and indefinite because it is unclear what is meant by "to increase the sensitivity of said charge pump circuit to touching of said touch terminal by an operator's body."

Claim Rejections - 35 USC § 102

2. The following is a quotation of the appropriate paragraphs of 35 U.S.C. 102 that form the basis for the rejections under this section made in this Office action:

A person shall be entitled to a patent unless --

(b) the invention was patented or described in a printed publication in this or a foreign country or in public use or on sale in this country, more than one year prior to the date of application for patent in the United States.

3. Claims 1-4 and 12-14 are rejected under 35 U.S.C. 102(b) as being anticipated by Kent. (4,352,141)

Kent discloses a capacitive responsive switching comprising: an oscillator (N5, N6, R1, C1) having a frequency of 1 MHZ, an input touch terminal (3), a detector circuit (E) coupled to said oscillator and said touch input terminal, DC power supply (1), wherein said periodic input signal provided by said oscillator is a square wave see column 2, lines 9-12, and a plurality of

Art Unit: 2107

active elements coupled to an output of said oscillator to buffer and improve the shape of the square wave output therefrom (C3, C4, R2), and a charge pump (D1, N1, R4, and C6).

Claim Rejections - 35 USC § 103

4. The following is a quotation of 35 U.S.C. 103(a) which forms the basis for all obviousness rejections set forth in this Office action:

(a) A patent may not be obtained though the invention is not identically disclosed or described as set forth in section 102 of this title, if the differences between the subject matter sought to be patented and the prior art are such that the subject matter as a whole would have been obvious at the time the invention was made to a person having ordinary skill in the art to which said subject matter pertains. Patentability shall not be negated by the manner in which the invention was made.

5. Claims 8-11, 18, and 19 are rejected under 35 U.S.C. 103(a) as being unpatentable over Kent in view of Ingraham (5,087,825).

Claims 8 and 9 add the limitations of a microcontroller. Kent does not disclose the detector circuit including a microcontroller. However, Ingraham discloses a detector circuit including a microcontroller. (80) It would have been obvious to one of ordinary skill in the art to replace the detector circuit of Kent with the detector circuit of Ingraham in order to provide a computerized control circuit that can control a plurality of different load requirements sent by a plurality of touch sensors.

Claims 10 and 11 add the limitations of a plurality of input touch terminals and a plurality of touch circuits. Kent only teaches one touch input terminal and one touch circuitry. However, Ingraham discloses a plurality of input touch terminals (18) with corresponding touch circuits. It would have been obvious to one of ordinary skill in the art at the time the invention was made to

Art Unit: 2107

utilize the teachings of Ingraham into Kent's device for the purpose of providing a plurality of ways in which the load may be controlled see column 2, lines 36-40.

As to claims 18 and 19, Kent discloses a capacitive responsive switching comprising: an oscillator (N5, N6, R1, C1) having a frequency of 1 MHZ, an input touch terminal (3), and a detector circuit (E) coupled to said oscillator and said touch input terminal. Kent only teaches one touch input terminal and one touch circuitry. However, Ingraham discloses a plurality of input touch terminals (18) with corresponding touch circuits. It would have been obvious to one of ordinary skill in the art at the time the invention was made to utilize the teachings of Ingraham into Kent's device for the purpose of providing a plurality of ways in which the load may be controlled see column 2, lines 36-40. Kent also does not disclose the details of the touch input comprising a dielectric substrate. However, Ingraham does disclose a touch sensor comprising a dielectric layer substrate (26). It would have been obvious to one of ordinary skill in the art at the time the invention was made to utilize the teachings of Ingraham into Kent's device as this is a well known way to activate a capacitor switch input.

6. Claims 8-11, 18, and 19 are rejected under 35 U.S.C. 103(a) as being unpatentable over Kent in view of Kirton (5,235,217).

Kent discloses a capacitive responsive switching comprising: an oscillator (N5, N6, R1, C1) having a frequency of 1 MHZ, an input touch terminal (3), and a detector circuit (E) coupled to said oscillator and said touch input terminal.

Art Unit: 2107

Kent does not disclose the shape of the touch terminal. However, Kirton discloses a touch terminal (14) which is domed shaped. It would have been obvious to one of ordinary skill in the art at the time the invention was made to utilize the teachings of Kirton into Kent's device for the purpose of providing a touch sensor which is easy to operate.

7. Claims 5 and 15 are objected to as being dependent upon a rejected base claim, but would be allowable if rewritten in independent form including all of the limitations of the base claim and any intervening claims.

8. Claims 6, 7, and 16 would be allowable if rewritten to overcome the rejection(s) under 35 U.S.C. 112 set forth in this Office action and to include all of the limitations of the base claim and any intervening claims.

Any inquiry concerning this communication or earlier communications from the examiner should be directed to Jonathan S. Kaplan whose telephone number is (703) 308-1216.

Any inquiry of a general nature or relating to the status of this application should be directed to the Group receptionist whose telephone number is (703) 308-1782.

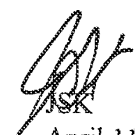
ASK
April 11, 1997

WILLIAM M. CHOOPER
SUPERVISORY PATENT EXAMINER
ART UNIT 217

Notice of References Cited

Application No. 08/601,268	Applicant(s) Hourmand
Examiner Jonathan S. Kaplan	Group Art Unit 2107
Page 1 of 1	

U.S. PATENT DOCUMENTS

	DOCUMENT NO.	DATE	NAME	CLASS	SUBCLASS
A	3,352,141 4,352,141	8/1993	Kirton	307	326
B	4,352,141	9/1982	Kent	363	181
C					
D					
E					
F					
G					
H					
I					
J					
K					
L					
M					

FOREIGN PATENT DOCUMENTS

	DOCUMENT NO.	DATE	COUNTRY	NAME	CLASS	SUBCLASS
N						
O						
P						
Q						
R						
S						
T						

NON-PATENT DOCUMENTS

	DOCUMENT (Including Author, Title, Source, and Pertinent Pages)	DATE
U		
V		
W		
X		

NOTICE OF DRAFTSPERSON'S PATENT DRAWING REVIEW

PTO Draftpersons review all originally filed drawings regardless of whether they are designated as formal or informal. Additionally, patent Examiners will review the drawings for compliance with the regulations. Direct telephone inquiries concerning this review to the Drawing Review Branch, 703-305-8404.

The drawings filed (insert date) 1/31/96, are

A. not objected to by the Draftsperson under 37 CFR 1.84 or 1.152.

B. objected to by the Draftsperson under 37 CFR 1.84 or 1.152 as indicated below. The Examiner will require submission of new, corrected drawings when necessary. Corrected drawings must be submitted according to the instructions on the back of this Notice.

- DRAWINGS.** 37 CFR 1.84(a): Acceptable categories of drawings:
 - Black ink. Color.
 - Not black solid lines. Fig(s) _____
 - Color drawings are not acceptable until petition is granted. Fig(s) _____
- PHOTOGRAPHS.** 37 CFR 1.84(b)
 - Photographs are not acceptable until petition is granted. Fig(s) _____
 - Photographs not properly mounted (must use brylston board or photographic double-weight paper). Fig(s) _____
 - Poor quality (half-tone). Fig(s) _____
- GRAPHIC FORMS.** 37 CFR 1.84(d)
 - Chemical or mathematical formula not labeled as separate figure. Fig(s) _____
 - Group of waveforms not presented as a single figure, using common vertical axis with time extending along horizontal axis. Fig(s) _____
 - Individuals waveform not identified with a separate letter designation adjacent to the vertical axis. Fig(s) _____
- TYPE OF PAPER.** 37 CFR 1.84(c)
 - Paper not flexible, strong, white, smooth, nonshiny, and durable. Sheet(s) _____
 - Measurements, alterations, overwritings, interlineations, cracks, creases, and folds copy machine marks not accepted. Fig(s) 1-200
 - Mylar, vellum paper is not acceptable (too thin). Fig(s) _____
- SIZE OF PAPER.** 37 CFR 1.84(f): Acceptable sizes:
 - 21.6 cm. by 35.6 cm. (8 1/2 by 14 inches)
 - 21.6 cm. by 33.1 cm. (8 1/2 by 13 inches)
 - 21.6 cm. by 27.9 cm. (8 1/2 by 11 inches)
 - 21.0 cm. by 29.7 cm. (DIN size A4)
 - All drawing sheets not the same size. Sheet(s) _____
 - Drawing sheet not an acceptable size. Sheet(s) _____
- MARGINS.** 37 CFR 1.84(g): Acceptable margins:

Paper size			
21.6 cm. X 35.6 cm. (8 1/2 X 14 inches)	21.6 cm. X 33.1 cm. (8 1/2 X 13 inches)	21.6 cm. X 27.9 cm. (8 1/2 X 11 inches)	21.0 cm. X 29.7 cm. (DIN Size A4)
T 5.1 cm. (2")	2.5 cm. (1")	2.5 cm. (1")	2.5 cm.
L .64 cm. (1/4")	.64 cm. (1/4")	.64 cm. (1/4")	2.3 cm.
R .64 cm. (1/4")	.64 cm. (1/4")	.64 cm. (1/4")	1.5 cm.
B .64 cm. (1/4")	.64 cm. (1/4")	.64 cm. (1/4")	1.0 cm.

Margins do not exceed more than above.

Sheet(s) 5, 12, 13, 15A, 17

Top (T) _____ Left (L) _____ Right (R) _____ Bottom (B) _____
- VIEWS.** 37 CFR 1.84(h)
 - REMINDER: Specification may require revision to correspond to drawing changes.
 - All views not grouped together. Fig(s) _____
 - Views connected by projection lines or lead lines. Fig(s) _____
 - Partial views. 37 CFR 1.84(h) 2
 - View and enlarged view not labeled separately or properly. Fig(s) _____
 - Sectional views. 37 CFR 1.84 (h) 3
 - Hatching not indicated for sectional portions of an object. Fig(s) _____
 - Cross section not drawn same as view with parts in cross section with regularly spaced parallel oblique strokes. Fig(s) _____
- ARRANGEMENT OF VIEWS.** 37 CFR 1.84(i)
 - Words do not appear on a horizontal, left-to-right fashion when page is either upright or turned so that the top becomes the right side, except for graphs. Fig(s) _____
- SCALE.** 37 CFR 1.84(k)
 - Scale not large enough to show mechanism with crowding when drawing is reduced in size to two-thirds in reproduction. Fig(s) _____
 - Indication such as "actual size" or scale 1/2" not permitted. Fig(s) _____
- CHARACTER OF LINES, NUMBERS, & LETTERS.** 37 CFR 1.84(l)
 - Lines, numbers & letters not uniformly thick and well defined, clean, durable, and black (except for color drawings). Fig(s) 1-200
- SHADING.** 37 CFR 1.84(m)
 - Solid black shading areas not permitted. Fig(s) _____
 - Shade lines, pale, rough and blurred. Fig(s) _____
- NUMBERS, LETTERS, & REFERENCE CHARACTERS.** 37 CFR 1.84(p)
 - Numbers and reference characters not plain and legible. (37 CFR 1.84(p)(1)) Fig(s) 1-200
 - Numbers and reference characters not oriented in same direction as the view. 37 CFR 1.84(p)(1) Fig(s) _____
 - English alphabet not used. 37 CFR 1.84(p)(2) Fig(s) _____
 - Numbers, letters, and reference characters do not measure at least .32 cm. (1/8 inch) in height. 37 CFR(p)(3) Fig(s) 5
- LEAD LINES.** 37 CFR 1.84(q)
 - Lead lines cross each other. Fig(s) _____
 - Lead lines missing. Fig(s) _____
- NUMBERING OF SHEETS OF DRAWINGS.** 37 CFR 1.84(t)
 - Sheets not numbered consecutively, and in Arabic numerals, beginning with number 1. Sheet(s) _____
- NUMBER OF VIEWS.** 37 CFR 1.84(u)
 - Views not numbered consecutively, and in Arabic numerals, beginning with number 1. Fig(s) _____
 - View numbers not preceded by the abbreviation Fig. Fig(s) _____
- CORRECTIONS.** 37 CFR 1.84(w)
 - Corrections not made from prior PTO-948. Fig(s) _____
- DESIGN DRAWING.** 37 CFR 1.152
 - Surface shading shown not appropriate. Fig(s) _____
 - Solid black shading not used for color contrast. Fig(s) _____

COMMENTS:

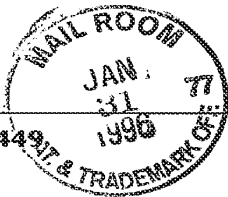

Form PTO-1449

U.S. DEPARTMENT OF COMMERCE
PATENT AND TRADEMARK OFFICE

ATTY. DOCKET NO.

SERIAL NO.

NAR01 P-310

05/601,268

INFORMATION DISCLOSURE STATEMENT
BY APPLICANT

APPLICANTS

Byron Hourmand

FILING DATE

GROUP

U.S. PATENT DOCUMENTS

EXAMINER INITIAL	PATENT NUMBER								ISSUE DATE	NAME	CLASS	SUBCLASS	FILING DATE IF APPROPRIATE
	5	4	5	3	6	4	4	9					
OK	5	4	5	3	6	4	4	09/26/95	Yap et al.				
	5	3	8	6	2	1	9	01/31/95	Greanias et al.				
	5	2	3	5	2	1	7	08/10/93	Kirton				
	5	2	3	3	2	3	1	08/03/93	Wieth et al.				
	5	2	0	8	5	1	6	05/04/93	Saidian				
	5	0	8	7	8	2	5	02/11/92	Ingraham				
	5	0	6	6	8	9	8	11/19/91	Miller et al.				
	5	0	1	2	1	2	4	04/30/91	Hollaway				
	4	9	3	9	3	8	2	07/03/90	Gruodis				
	4	9	1	0	5	0	4	03/20/90	Eriksson				
	4	8	3	1	2	7	9	05/16/89	Ingraham				
	4	7	5	8	7	3	5	07/19/88	Ingraham				
	4	7	3	1	5	4	8	03/15/88	Ingraham				
	4	4	7	6	4	6	3	10/09/84	Ng et al.				
	4	3	7	4	3	8	1	02/15/83	Ng et al.				
	4	3	6	0	7	3	7	11/23/82	Leopold				
	4	3	2	3	8	2	9	04/06/82	Witney et al.				
	4	3	0	8	4	4	3	12/29/81	Tucker et al.				
4	2	8	9	9	8	0	09/15/81	McLaughlin					
4	2	8	9	9	7	2	09/15/81	Wern					
4	2	6	4	8	3	1	04/28/81	Wern					
4	2	5	7	1	1	7	03/17/81	Besson					

FOREIGN PATENT DOCUMENTS

DOCUMENT NUMBER	PUBLICATION DATE	COUNTRY	CLASS	SUBCLASS	TRANSLATION	
					YES	NO

OTHER DOCUMENTS (Including Author, Title, Date, Pertinent Pages, Etc.)

--	--	--

EXAMINER

Jonathan Kaplan

DATE CONSIDERED

4/11/97

EXAMINER: Initial if citation is considered, whether or not citation is in conformance with MPEP 609; Draw line through citation if not in conformance and not considered. Include copy of this form with next communication to applicant.



Form PTO-1449

U.S. DEPARTMENT OF COMMERCE
PATENT AND TRADEMARK OFFICE

ATTY. DOCKET NO.

SERIAL NO.

NAR01 P-310

08/601268

INFORMATION DISCLOSURE STATEMENT
BY APPLICANT

APPLICANTS

Byron Hourmand

FILING DATE

GROUP

U.S. PATENT DOCUMENTS

EXAMINER INITIAL	PATENT NUMBER								ISSUE DATE	NAME	CLASS	SUBCLASS	FILING DATE IF APPROPRIATE
OK	4	2	4	6	5	3	3	01/20/81	Chiang				
	4	2	3	7	4	2	1	12/02/80	Waldron				
	4	2	2	0	8	1	5	09/02/80	Gibson et al.				
	4	2	1	3	0	6	1	07/15/80	Conner				
	4	2	1	1	9	5	9	07/08/80	Deavenport et al.				
	4	2	1	0	8	2	2	07/01/80	Wern				
	4	1	5	9	4	7	3	06/26/79	Senk				
	4	1	5	2	6	2	9	05/01/79	Raupp				
	4	1	1	9	8	6	4	10/10/78	Petrizio				
	4	1	0	1	8	0	5	07/18/78	Stone				
	4	0	7	1	6	8	9	01/31/78	Talmage et al.				
	4	0	3	1	4	0	8	06/21/77	Holz				
	4	0	1	6	4	5	3	04/05/77	Moennig				
	3	9	8	4	7	5	7	10/05/76	Gott et al.				
	3	9	6	5	4	6	5	06/22/76	Alexander				
	3	9	1	9	5	9	6	11/11/75	Bellis				
	3	9	1	1	2	1	5	10/07/75	Hurst et al.				
	3	8	9	9	7	1	3	08/12/75	Barkan et al.				
	3	7	9	8	3	7	0	03/19/74	Hurst				
	3	6	6	6	9	8	8	05/30/72	Bellis				
3	6	5	1	3	9	1	03/21/72	Vogelsberg					
3	6	4	1	4	1	0	02/08/72	Vogelsberg					
3	5	4	9	9	0	9	08/25/69	Adelson et al.					

FOREIGN PATENT DOCUMENTS

DOCUMENT NUMBER	PUBLICATION DATE	COUNTRY	CLASS	SUBCLASS	TRANSLATION	
					YES	NO

OTHER DOCUMENTS (Including Author, Title, Date, Pertinent Pages, Etc.)

--

EXAMINER

Jonathan Kaplan

DATE CONSIDERED

4/11/97

EXAMINER: Initial if citation is considered, whether or not citation is in conformance with MPEP 609; Draw line through citation if not in conformance and not considered. Include copy of this form with next communication to applicant.

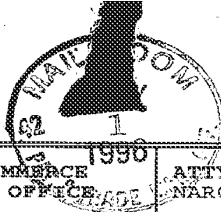

5/1/96

FORM PTO-1449 U.S. DEPARTMENT OF COMMERCE (Rev. 2-32) PATENT AND TRADEMARK OFFICE INFORMATION DISCLOSURE STATEMENT BY APPLICANT (Use several sheets if necessary)	ATTY. DOCKET NO. NAR01 P-310	SERIAL NO. 08/601,268 (unofficial)
	APPLICANT(S) Byron Hourmand	
	FILING DATE 01/31/96	GROUP

U.S. PATENT DOCUMENTS

EXAMINER INITIAL	DOCUMENT NUMBER	DATE	NAME	CLASS	SUB-CLASS	FILING DATE IF APPROPRIATE	
						Y	N
	3 8 7 9 6 1 8	04/22/75	Larson	367	116		
	4 5 0 3 2 9 4	03/05/85	Matsumaru	200	5A		
	4 9 4 2 6 3 1	07/24/90	Rosa	4	623		

FOREIGN PATENT DOCUMENTS

EXAMINER INITIAL	DOCUMENT NUMBER	DATE	COUNTRY	CLASS	SUB-CLASS	TRANSLATION	
						Y	N

OTHER DOCUMENTS (Including Author, Title, Date, Pertinent Pages, Etc.)

EXAMINER INITIAL	DOCUMENT NUMBER	DATE	OTHER INFORMATION

EXAMINER	Jonathan Kaplan	DATE CONSIDERED	4/11/97
EXAMINER: Initial if citation considered, whether or not citation is in conformance with MPEP 609; Draw line through citation if not in conformance and not considered. Include copy of this form with next communication to applicant.			



Atty. Docket No. NAR01 P-310

IN THE UNITED STATES PATENT AND TRADEMARK OFFICE

Art Unit : 2107
Examiner : J. Kaplan
Appln. No. : 08/601,268
Filing Date : January 31, 1996
Applicant : Byron Hourmand
For : CAPACITIVE RESPONSIVE ELECTRONIC SWITCHING CIRCUIT

10

Assistant Commissioner for Patents
Washington, D.C. 20231

RECEIVED
SEP 22 1997
GROUP 2100

Dear Sir:

AMENDMENT

This is a response to the Office Action mailed April 22, 1997. The time for filing a response to the Office Action has been extended by the petition for a one-month extension of time and payment of the appropriate fee filed concurrently with this amendment. Applicant requests that the Examiner amend the above-captioned application as follows.

In the Drawings:

Subject to the approval of the Examiner, please amend Figs. 1, 3, 4, 5, 11, 12, 13, 14, and 18 as shown in red on the attached sheets of drawings.

In the Specification:

Please amend the specification as follows:

- Page 1, line 9, change "movement" to --movements--.
- Page 2, line 17, after "is" insert --(are)--.
- Page 12, line 1, change "ground" to --common--.
- Page 12, line 5, change "approved" to --listed--.
- Page 12, line 9, change "ground" to --floating common--.
- Page 12, line 12, delete "true".

Applicant : Byron Hourmand
Appl. No. : 08/601,268
Page : 2

- ✓ Page 13, line 19, after "operator" insert --to--.
- ✓ Page 14, line 2, after "capacitance" insert --to ground--.
- ✓ Page 15, line 2, change "ground" to --common--.
- ✓ Page 17, line 9, change "an external" to --a--.
- ✓ Page 17, line 12, change "ZB" to --Z_B--.
- ✓ Page 18, line 11, change "ZW" to --Z_W--.
- ✓ Page 21, line 11, change "an external" to --a--.
- ✓ Page 21, line 16, change "it's" to --its--.
- ✓ Page 23, line 12, change "will" to --well--.
- ✓ Page 23, line 20, delete "preferably".
- ✓ Page 25, line 7, delete "relative to an external ground such as the earth".
- ✓ Page 26, line 4, change "ground" to --common--.
- ✓ Page 26, line 6, change "ground" to --common--.
- ✓ Page 26, line 7, change "ground" to --common--.
- ✓ Page 26, line 9, change "ground" to --common--.
- ✓ Page 26, line 10, change "ground" to --common-- (both occurrences).
- ✓ Page 26, line 12, change "ground" to --common--.
- ✓ Page 26, line 14, after "capacitance" insert --to ground--.
- ✓ Page 26, line 17, after "capacitance" insert --to ground--.
- ✓ Page 29, line 13, change "coupled" to --directly connected--.
- ✓ Page 29, line 14, change "coupled" to --directly connected--.

Applicant : Byron Hourmand
Appl. No. : 08/601,268
Page : 3

Page 29, line 14, delete "output of the".

Page 29, line 14, change "213" to --216--.

Page 30, line 8, after "between" insert --near to--.

Page 30, line 15, change "generate" to --the floating common generator 300 such that

a' together they supply a--.

Page 30, line 16, change "and powers up" to --to power--.

Page 30, line 16, change "circuits" to --circuit(s)--.

Page 31, line 4, change "must" to --can--.

Page 31, line 6, delete "and preferably".

Page 31, line 17, delete "between the".

Page 31, line 18, delete "collector of transistor 410 and floating ground line 301".

Page 32, line 11, after "includes" insert --resistor 412 and--.

Page 32, line 12, before "resistor" insert --to--.

Page 32, line 16, change "Resistor 413 is used to limit the base current." to --The

a2 base of transistor 410 is connected via resistor 413 to line 451 connected to touch pad 450.--.

Page 33, line 5, after "capacitance" insert --to ground--.

Page 33, line 11, after "capacitance" insert --to ground--.

Page 33, line 11, delete "earth".

Page 33, line 15, after "reverse" insert --bias--.

Page 33, line 15, change "thereby reducing" to --and also reduce--.

Page 40, line 11, after "length" insert --451--.

60

Applicant : Byron Hourmand
Appl. No. : 08/601,268
Page : 4

- Page 40, line 11, change "pad 451" to --pad 450--.
- Page 41, line 9, change "and an earth relative ground" to --with ground connection--.
- Page 41, line 10, after "1103," delete "and".
- Page 42, line 9, change "to relative earth ground 1103" to --via line 1103 to ground--.
- Page 42, line 17, change "power line" to --power common line--.
- Page 42, line 17, delete "relative".
- Page 44, line 8, change "a transistor" to --a bipolar PNP transistor--.
- Page 44, line 8, change "1420" to --1420a--.
- Page 44, line 9, change "power line" to --power common line--.
- Page 44, line 18, change "1424" to --1424a--.
- Page 45, line 2, change "power line" to --power common line--.
- Page 45, line 4, change "negative" to --inverting input--.
- Page 45, line 4, change "positive" to --non-inverting input--.
- Page 45, line 11, change "power line" to --power common line--.
- Page 45, line 12, after "base of" insert --bipolar PNP--.
- Page 45, line 13, change "power line" to --power common line--.
- Page 46, line 4, change "power line" to --power common line--.
- Page 46, line 5, change "negative" to --inverting input--.
- Page 46, line 6, change "positive" to --non-inverting input--.
- Page 46, line 7, change "positive" to --non-inverting input--.
- Page 46, line 8, change "power line" to --power common line--.

Applicant : Byron Hourmand
Appl. No. : 08/601,268
Page : 5

- Page 46, line 10, change "1639" to --1630--.
- Page 46, line 11, change "positive" to --non-inverting--.
- Page 46, line 12, change "invertor gate" to --invertor NAND gate--.
- Page 46, line 14, change "invertor gate" to --invertor NAND gate--.
- Page 46, line 15, change "invertor gate" to --invertor NAND gate-- (both occurrences).
- Page 46, line 15, change "power line" to --power common line--.
- Page 46, line 16, after "switching" insert --bipolar PNP--.
- Page 46, line 17, change "power line" to --power common line--.
- Page 47, line 15, change "(1628)" to --(invertor NAND gate 1628)--.
- Page 47, line 17, change "(1536)" to --(1636)--.
- Page 47, line 18, after "when" insert --the--.
- Page 47, line 19, change "button" to --touch terminal--.
- Page 48, line 15, after "one" insert --of the touch switch circuits--.
- Page 48, line 15, after "redundant" insert --relay driver--.
- Page 48, line 16, after "one" insert --of the driver circuits--.
- Page 48, line 20, change "2201" to --2205. Palm button 2201--.
- Page 49, line 1, delete "second" (first occurrence).
- Page 50, line 6, change "sid" to --side--.
- Page 51, line 4, after "smaller" insert --series--.
- Page 51, line 6, after "body" insert --to ground-- (both occurrences).

Applicant : Byron Hourmand
Appl. No. : 08/601,268
Page : 6

Page 51, line 8, after "capacitance" insert --to ground--.

Page 51, line 10, change "earth" to --ground--.

Page 53, line 1, change "decrease and increase" to --adjust--.

Page 53, line 2, delete "respectively".

Page 53, line 5, after "200" insert --(Fig. 6)-- (first occurrence).

Page 53, line 10, change "pulls" to --sources--.

In the Abstract:

Please amend the abstract as follows:

Line 6, before "touch" insert --proximity and--.

Line 9, after "capacitance" insert --to ground--.

Line 9, after "when" insert --in proximity or--.

In the Claims:

Please amend claims 1, 3, 5, 6, 12-18, and 20, and add new claims 21-32 as follows:

1. (Amended) A capacitive responsive electronic switching circuit comprising:

an oscillator providing a periodic output signal having a frequency of 50 kHz or greater;

an input touch terminal having a dielectric cover defining an area for an operator to provide an input by proximity and touch, an operator's body capacitance to ground as sensed through said input touch terminal varying as a function of the area of said input touch terminal that is proximate the operator's body; and

Applicant : Byron Hourmand
Appl. No. : 08/601,268
Page : 7

AP
Cmd

a detector circuit coupled to said oscillator for receiving said periodic output signal from said oscillator, and coupled to said input touch terminal, said detector circuit being responsive to signals from said oscillator and the presence of an operator's body capacitance to ground coupled to said touch terminal when proximal or touched by an operator to provide a control output signal, wherein said detector circuit includes means for generating said control signal when the sensed body capacitance to ground exceeds a threshold level in order to prevent unintended activation based upon an operator's inadvertent proximity and touch with said input touch terminal.

[\

Claim 3, line 2, delete "reference to an external".

9. → (Amended) A capacitive responsive electronic [The] switching circuit [as defined in claim 1 and further including] comprising:

an oscillator providing a periodic output signal having a frequency of 50 kHz or greater;

an input touch terminal defining an area for an operator to provide an input by proximity and touch;

a detector circuit coupled to said oscillator for receiving said periodic output signal from said oscillator, and coupled to said input touch terminal, said detector circuit being responsive to signals from said oscillator and the presence of an operator's body capacitance

Applicant : Byron Hourmand
Appl. No. : 08/601,268
Page : 8

to ground coupled to said touch terminal when proximal or touched by an operator to provide a control output signal; and

a floating [ground] common generator coupled to said oscillator for receiving said square wave output signal, said floating [ground] common generator generating a floating [ground] common reference for said detector circuit that is set at a fixed voltage below and tracks the square wave output signal.

10. ~~6.~~ (Amended) The switching circuit as defined in claim ⁹~~5~~, wherein said detector circuit is powered by said square wave output signal provided by said oscillator and by said floating [ground] common reference provided by said floating [ground] common generator [to increase] thereby increasing the sensitivity of said detector circuit to proximity and touching of said touch terminal by an operator's body.

12. (Amended) A proximity and touch controlled switching circuit comprising:

an oscillator providing a square wave output signal having a frequency of 50 kHz or greater;

a touch terminal having a dielectric cover defining an input terminal for coupling to an operator's body capacitance to ground; and

a charge pump circuit coupled to said oscillator for receiving said square wave output signal, and coupled to said touch terminal, said charge pump circuit having an output terminal that supplies an output signal having a voltage that varies when said touch terminal

Applicant : Byron Hourmand
Appl. No. : 08/601,268
Page : 9

is proximal or touched by an operator's body, the voltage of said output signal varies as a function of the area of said touch terminal that is proximal or touched by an operator,

wherein said charge pump circuit includes at least one high speed diode coupled between said oscillator and said touch terminal, for enhancing a sensitivity at which said charge pump responds to sensed body capacitance to ground at said touch terminal for higher frequencies.

AS
cond.

13. (Amended) The [touch control] proximity and touch controlled circuit as defined in claim 12 and further including a DC power supply for supplying power to said oscillator and a [reference to an external] ground.

[

Claim 14, line 1, change "touch control" to --proximity and touch controlled--.

16.

~~15.~~ (Amended) A proximity and [The] touch [control] controlled switching circuit [as defined in claim 12 and further including] comprising:

an oscillator providing a square wave output signal having a frequency of 50 kHz or greater;

a touch terminal defining an input terminal for coupling to an operator's body capacitance to ground;

a charge pump circuit coupled to said oscillator for receiving said square wave output signal, and coupled to said touch terminal, said charge pump circuit having an output

Ab

64

Applicant : Byron Hourmand
Appl. No. : 08/601,268
Page : 10

terminal that supplies an output signal having a voltage that varies when said touch terminal is proximal or touched by an operator's body; and

a floating [ground] common generator coupled to said oscillator for receiving said square wave output signal, said floating [ground] common generator generating a floating [ground] common reference for said charge pump circuit that is set at a fixed voltage below and tracks said square wave output signal,

wherein said charge pump circuit includes at least one high speed diode coupled between said oscillator and said touch terminal, for enhancing a sensitivity at which said charge pump responds to sensed body capacitance to ground at said touch terminal for higher frequencies.

Ab
Amil

17. ¹⁶
~~16.~~ (Amended) The proximity and touch [control] controlled circuit as defined in claim ~~15~~,
wherein said charge pump circuit is powered by said square wave output signal provided by said oscillator and by said floating [ground] common reference provided by said floating [ground] common generator [to increase] thereby increasing the sensitivity of said charge pump circuit to proximity and touching of said touch terminal by an operator's body.

[

Claim 17, line 1, change " touch control" to --proximity and touch controlled--.

65

Applicant : Byron Hourmand
Appl. No. : 08/601,268
Page : 11

18. (Amended) A capacitive responsive electronic switching circuit comprising:

an oscillator providing a periodic output signal having a predefined frequency;

a plurality of input touch terminals defining adjacent areas on a dielectric substrate for an operator to provide inputs by proximity and touch; and

MB
AT
a detector circuit coupled to said oscillator for receiving said periodic output signal from said oscillator, and coupled to said input touch terminals, said detector circuit being responsive to signals from said oscillator and the presence of an operator's body capacitance to ground coupled said touch terminals when proximal or touched by an operator to provide a control output signal,

wherein said predefined frequency of said oscillator is selected to decrease the impedance of said dielectric substrate relative to the impedance of any contaminate that may create an electrical on said dielectric substrate path between said adjacent areas, and wherein said detector circuit compares the sensed body capacitance to ground proximate an input touch terminal to a threshold level to prevent inadvertent generation of the control output signal.

AS
20. (Amended) A capacitive responsive electronic switching circuit comprising:

an oscillator providing a periodic output signal having a predefined frequency;

a dome-shaped touch terminal defining an area for an operator to provide an input by proximity and touch, wherein the dome shape of the touch terminal is constructed to ergonomically fit the palm of a human hand; and

66

Applicant : Byron Hourmand
Appl. No. : 08/601,268
Page : 12

AG
am

a detector circuit coupled to said oscillator for receiving said periodic output signal from said oscillator, and coupled to said [input] touch terminal [terminals], said detector circuit being responsive to signals from said oscillator and the presence of an operator's body capacitance to ground coupled to said touch [terminals] terminal when proximal or touched by an operator to provide a control output signal, said detector circuit including means for discriminating between a proximity and touch of said dome-shaped touch terminal by the palm of a human hand and a proximity and touch by a human finger.

21. (New) A capacitive responsive electronic switching circuit comprising:

an oscillator providing a periodic output signal having a predefined frequency;

a touch terminal defining an area for an operator to provide an input by proximity and touch; and

AG

a detector circuit coupled to said oscillator for receiving said periodic output signal from said oscillator, and coupled to said touch terminal, said detector circuit being responsive to signals from said oscillator and the presence of an operator's body capacitance to ground coupled to said touch terminal when proximal or touched by an operator to provide a control output signal, said detector circuit including discriminating means for discriminating between a proximity and touch of said touch terminal covering substantially all of said area of said touch terminal and a proximity and touch covering less than substantially all of said area of said touch terminal.

Applicant : Byron Hourmand
Appl. No. : 08/601,268
Page : 13

22. (New) The switching circuit as defined in claim 21, wherein said touch terminal includes a dome-shaped dielectric cover.

23. (New) The switching circuit as defined in claim 21, wherein said touch terminal includes a palm-sized dielectric cover.

24. (New) The switching circuit as defined in claim 23, wherein said discriminating means determines that a proximity and touch of said touch terminal covers substantially all of said area of said touch terminal when said dielectric cover is proximal or touched with the palm of an operator's hand and determines that a proximity or touch covers less than substantially all of said area of said touch terminal when said dielectric cover is proximal or touched with one of an operator's fingers.

25. (New) The switching circuit as defined in claim 21, wherein said discriminating means discriminates between a proximity and touch of said touch terminal covering substantially all of said area of said touch terminal and a proximity and touch covering less than substantially all of said area of said touch terminal based upon a sensed level of body capacitance to ground proximate said touch terminal.

CG
Com 4.

68

Applicant : Byron Hourmand
Appl. No. : 08/601,268
Page : 14

26. (New) The switching circuit as defined in claim 21, wherein said coupling of capacitance to ground occurs when an operator's body is proximate, but not touching, said touch terminal.

27. (New) A capacitive responsive electronic switching circuit for a controlled device comprising:

69
Cont.

an oscillator providing a periodic output signal having a predefined frequency;
first and second touch terminals defining areas for an operator to provide an input by proximity and touch; and
a detector circuit coupled to said oscillator for receiving said periodic output signal from said oscillator, and coupled to said first and second touch terminals, said detector circuit being responsive to signals from said oscillator and the presence of an operator's body capacitance to ground coupled to said first and second touch terminals when proximal or touched by an operator to provide a control output signal for actuation of the controlled device, said detector circuit being configured to generate said control output signal when said an operator is proximal or touches said second touch terminal after the operator is proximal or touches said first touch terminal.

69

28. (New) The capacitive responsive electronic switching circuit as defined in claim 27, wherein said detector circuit generates said control signal only when an operator is proximal

Applicant : Byron Hourmand
Appl. No. : 08/601,268
Page : 15

or touches said second touch terminal within a predetermined time period after the operator is proximal or touches said first touch terminal.

29. (New) The capacitive responsive electronic switching circuit as defined in claim 27, wherein said first and second touch terminals are adapted to be mounted on different surfaces of the controlled device.

29
Cont.
30. (New) The capacitive responsive electronic switching circuit as defined in claim 27, wherein said first and second touch terminals are adapted to be mounted on non-parallel planar surfaces of the controlled device.

31. (New) The capacitive responsive electronic switching circuit as defined in claim 27, wherein said first and second touch terminals are adapted to be mounted on perpendicular planar surfaces of the controlled device.

32. (New) The capacitive responsive electronic switching circuit as defined in claim 27 and further including an indicator for indicating when said detector circuit determines that an operator is proximal or touches said first touch terminal.

70

Applicant : Byron Hourmand
Appl. No. : 08/601,268
Page : 16

REMARKS

In the Office Action, the Examiner indicated that claims 5 and 15 would be allowed if rewritten in independent form including all the limitations of the base claim and any intervening claims, and that claims 6, 7, and 16 would also be allowed if rewritten to overcome the rejection under 35 U.S.C. §112. Applicant wishes to thank the Examiner for the early indication of allowable subject matter. By this amendment, Applicant has amended claims 5 and 15 by rewriting them in independent form and by amending claims 6 and 16 to overcome the rejection under 35 U.S.C. §112. Therefore, claims 5-7, 15, and 16 are in condition for allowance.

In the Office Action, the Examiner rejected claims 6, 7, and 16 under 35 U.S.C. §112, second paragraph; rejected claims 1-4 and 12-14 under 35 U.S.C. §102(b) as being anticipated by U.S. Patent No. 4,352,141 issued to Kent; rejected claims 8-11, 18, and 19 under 35 U.S.C. §103 as being unpatentable over Kent in view of U.S. Patent No. 5,087,825 issued to Ingraham; and rejected claims 8-11, 18, and 19 under 35 U.S.C. §103 as being unpatentable over Kent in view of U.S. Patent No. 5,235,217 issued to Kirton.

By this amendment, Applicant has amended claims 1, 5, 6, 12-18, and 20 to more clearly define the present invention, and has added new claims 21-32 to define additional features of the present invention. Accordingly, claims 1-32 are now pending.

With respect to the rejection of claims 6, 7, and 16 under 35 U.S.C. §112, second paragraph, Applicant has amended claims 6 and 16 to more clearly recite the present

Applicant : Byron Hourmand
Appl. No. : 08/601,268
Page : 17

invention. Applicant submits that amended claims 6, 7, and 16 meet the requirements of 35 U.S.C. §112, second paragraph.

Applicant respectfully traverses the rejection of claims 1-4 and 12-14 under 35 U.S.C. §102(b) as being anticipated by Kent. As pointed out on page 51 of the present specification, the present invention provides a mechanism by which the touch control circuit can discriminate between an intentional touching of the touch terminal and an inadvertent contact by the operator. Specifically, when the touch terminal is palm-sized and includes a dielectric cover, users may intentionally touch the touch terminal by placing their palm over the entire surface of the touch terminal. When the operator touches the touch terminal in this manner, the touch control circuit of the present invention generates a control signal. On the other hand, if the operator inadvertently touches the touch terminal with one or two fingers, the touch control circuit of the present invention senses a lower body capacitance in the proximity of the touch terminal and thereby determines that the touch was unintentional and thus does not generate the control signal.

As amended, independent claim 1 recites a capacitive response electronic switching circuit comprising a combination of elements including at least "an input touch terminal having a dielectric cover defining an area for an operator to provide an input by touch, an operator's body capacitance as sensed through said input touch terminal varying as a function of the area of said input touch terminal that is proximate the operator's body," and a detector circuit that "includes means for generating said control signal when the sensed body

Applicant : Byron Hourmand
Appln. No. : 08/601,268
Page : 18

capacitance exceeds a threshold level in order to prevent unintended activation based upon an operator's inadvertent contact with said input touch terminal."

The Kent patent discloses a touch switch device that also generates the control signal in response to the touching of a touch terminal. The Kent patent, however, fails to teach or suggest a capacitive responsive electronic switching circuit having a detector circuit that includes means for generating a control signal when the sensed body capacitance exceeds a threshold level in order to prevent unintended activation based upon an operator's inadvertent contact with the input touch terminal. Thus, the Kent patent does not anticipate nor render obvious the invention as defined in independent claim 1. Clearly, the Kent patent does not disclose any way of discriminating between a partial touch and a full touch of the touch terminal.

With respect to independent claim 12, the Kent patent fails to teach or suggest a touch-controlled switching circuit comprising a charge pump circuit that supplies an output signal having a voltage that varies as a function of the area of the touch terminal that is touched by an operator. Therefore, the Kent patent fails to teach or suggest each and every element recited in independent claim 12.

For these reasons, independent claims 1 and 12, as well as claims 2-4, 13, and 14 which depend therefrom, are allowable over the Kent patent.

Applicant respectfully traverses the rejection of claims 8-11, 18, and 19 under 35 U.S.C. §103 as being unpatentable over Kent in view of Ingraham. Like the Kent patent, the Ingraham patent, which is assigned to the assignee of the present invention, fails to teach

Applicant : Byron Hourmand
Appl. No. : 08/601,268
Page : 19

or suggest a touch control circuit that discriminates between a full intentional contact with a touch terminal and an inadvertent partial contact of the same touch terminal. Therefore, the combination of the Kent and Ingraham patents fails to teach or suggest each and every element recited in independent claim 1. For this reason claims 8-11, which depend from independent claim 1, are allowable over the combination of the Kent and Ingraham patents.

With respect to independent claim 18, the Kent and Ingraham patents both fail to teach or suggest a capacitive responsive electronic switching circuit comprising a detector circuit that compares the sensed body capacitance proximate an input touch terminal to a threshold level in order to prevent inadvertent generation of a control output signal. For these reasons, Applicant submits that independent claims 1 and 18, as well as claims 8-11 and 19 which depend therefrom, are allowable over the Kent and Ingraham patents whether considered separately or in combination.

Applicant respectfully traverses the rejection of claims 8-11, 18, and 19 under 35 U.S.C. §103 as being unpatentable over Kent in view of Kirton. The Kirton patent, like the Kent and Ingraham patents, does not disclose a touch control circuit that is capable of discriminating between a full intentional touch of a touch terminal and an inadvertent touch of a portion of the surface of the touch terminal. For these reasons, independent claims 1 and 18, as well as claims 8-11 and 19 which depend therefrom, are allowable over the teachings of the Kent and Kirton patents whether considered separately or in combination.

It is noted that the Examiner has not rejected claims 17 and 20 in the Office Action. Claim 17 depends from independent claim 12 and is believed to be allowable for the reasons

Applicant : Byron Hourmand
Appln. No. : 08/601,268
Page : 20

discussed above with respect to claim 12. Independent claim 20 recites a dome-shaped touch terminal. By this amendment, Applicant has amended independent claim 20 to recite that the detector circuit includes means for discriminating between a touch of the dome-shaped touch terminal by the palm of a human hand and a touch by a human finger. For the reasons stated above with respect to independent claims 1, 12, and 18, Applicant submits that independent claim 20 is allowable over the combined teachings of the Kent, Ingraham, and Kirton patents.

In this amendment, Applicant has presented new independent claim 21, and claims 22-26 which depend therefrom. New independent claim 21 defines a capacitive responsive electronic switching circuit comprising at least a detector circuit "including discriminating means for discriminating between the touch of said touch terminal covering substantially all of said area of said touch terminal and a touch covering less than substantially all of said area of said touch terminal. For the reasons discussed above with respect to the other independent claims, Applicants submit that neither the Kent, Ingraham, nor Kirton patents teach or suggest the touch control circuit including a detector circuit having such discriminating means. Therefore, new independent claim 21 as well as claims 22-26 are allowable over the references cited of record.

New independent claim 27 recites a switching circuit for a control device that comprises at least first and second touch terminals and a detector circuit that generates a control output signal for actuation of the control device when an operator is proximal or touches the second touch terminal after the operator is proximal or touches the first touch

Applicant : Byron Hourmand
Appl. No. : 08/601,268
Page : 21

terminal. Dependent claim 28 recites that the detector circuit generates the control signal only when the second touch terminal is actuated within a predetermined time period after the actuation of the first touch terminal. Applicant submits that none of the cited references teaches or suggests such features. New claims 29-32 depend from new independent claim 27 and are believed to be allowable for the same reasons stated above with respect to independent claim 27.

In view of the foregoing amendments and remarks, Applicant submits that the present invention as defined in the pending claims, is allowable over the prior art of record. The Examiner's reconsideration and timely allowance of the claims are requested. A Notice of Allowance is therefore respectfully solicited.

Respectfully submitted,

BYRON HOURMAND

By: Price, Heneveld, Cooper,
DeWitt & Litton

8-22-97
Date

Terry S. Callaghan
Registration No. 34 559
695 Kenmoor, S.E.
Post Office Box 2567
Grand Rapids, Michigan 49501
(616) 949-9610

TSC/ras

Att #10

OK to enter
D/C 10/24/87

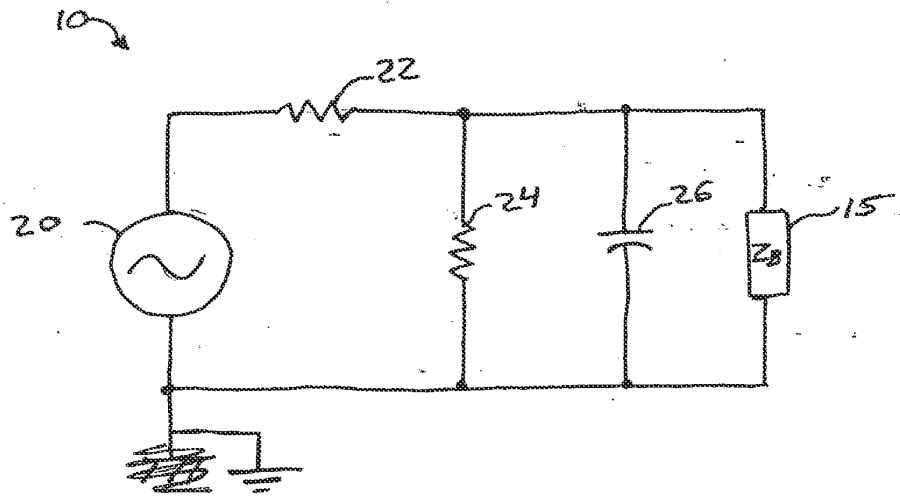

FIG. 1

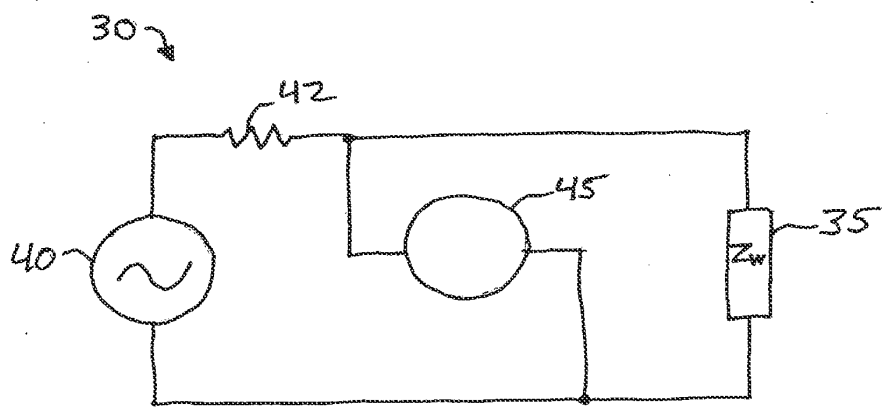

FIG. 2

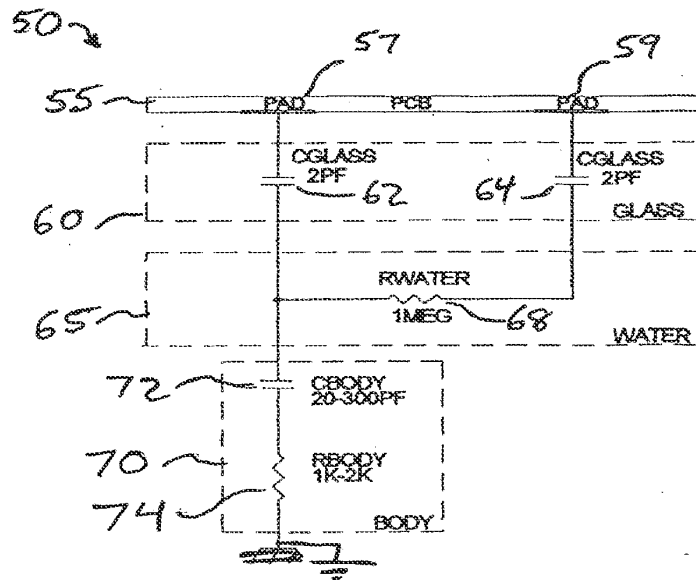

FIG. 3

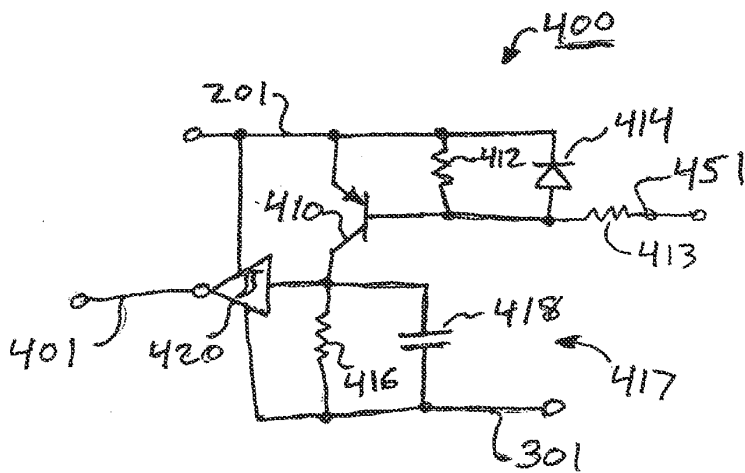

FIG. 8

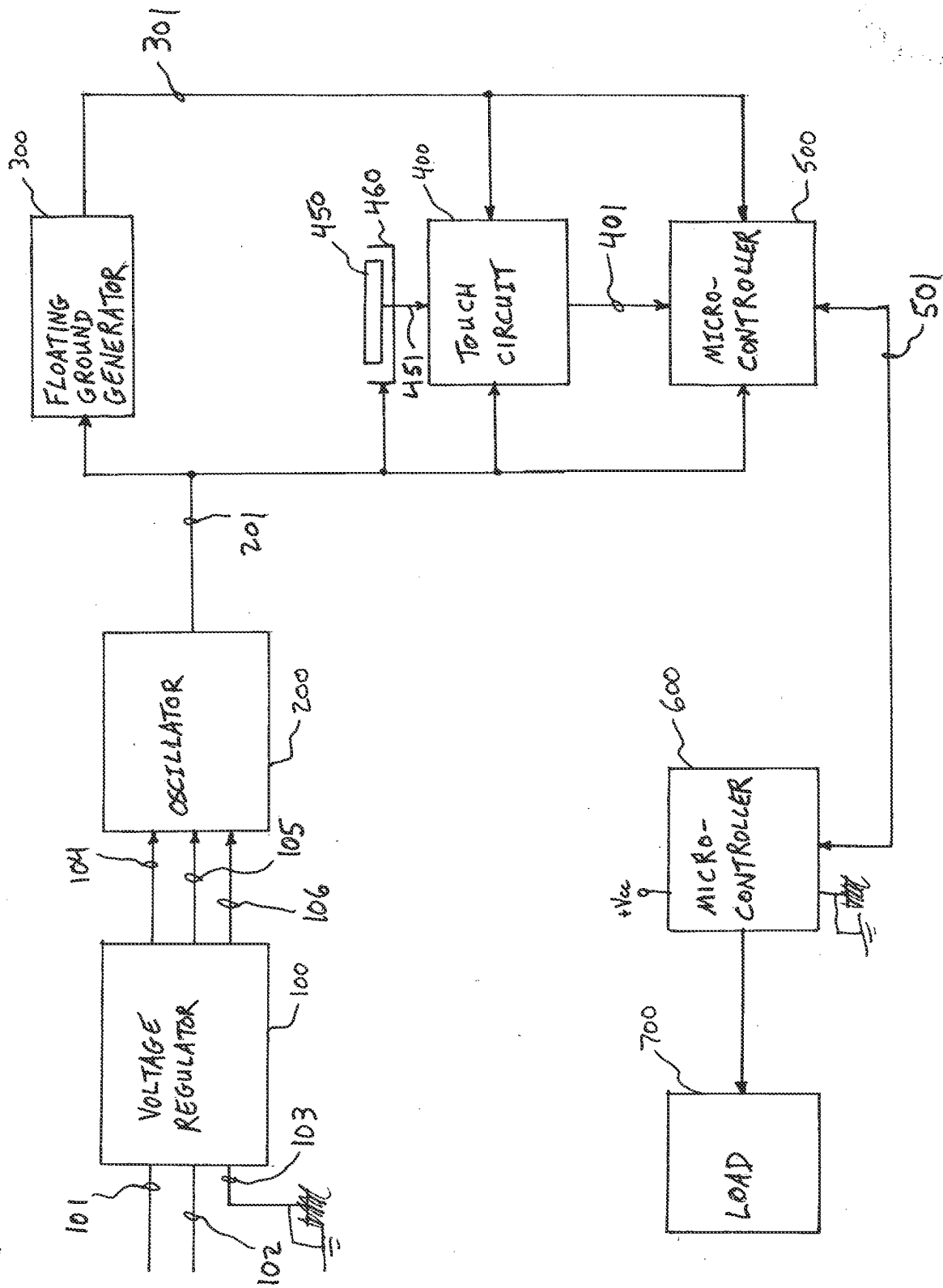

FIG. 4

FIG. 5

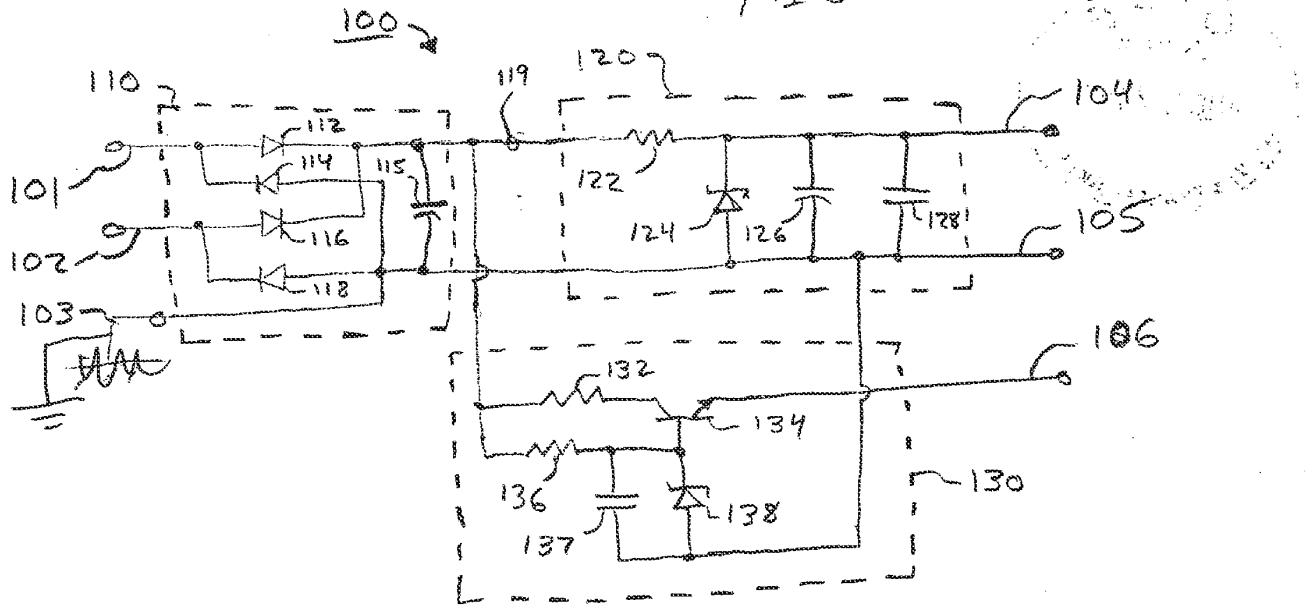

FIG. 6

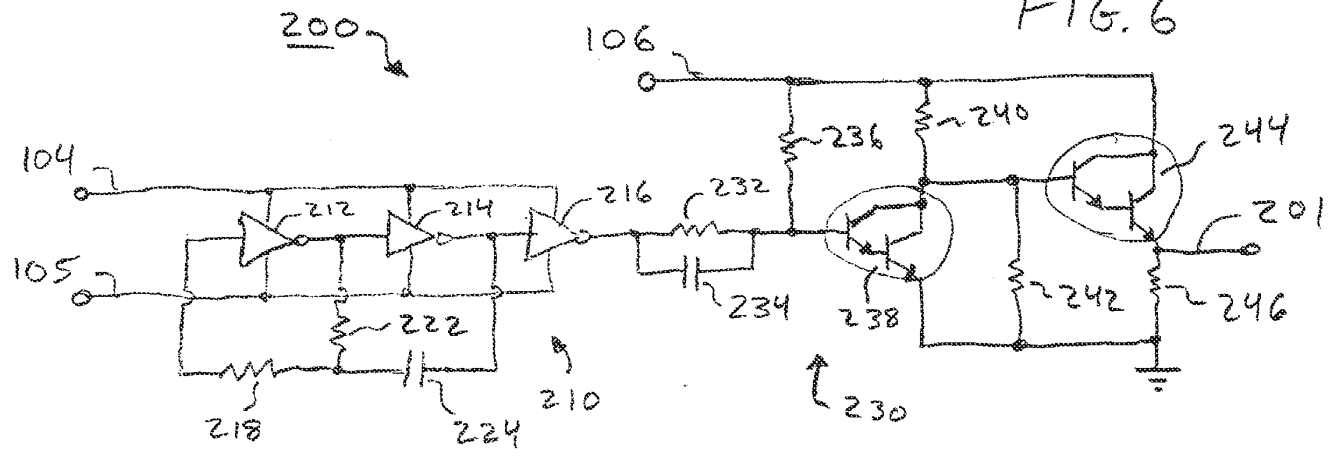
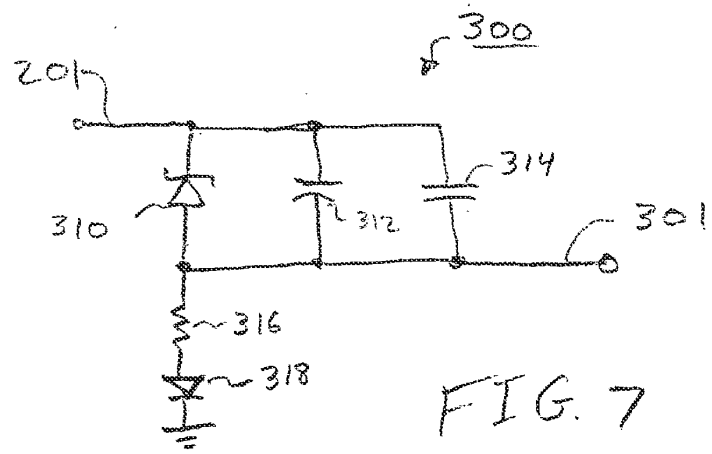

FIG. 7



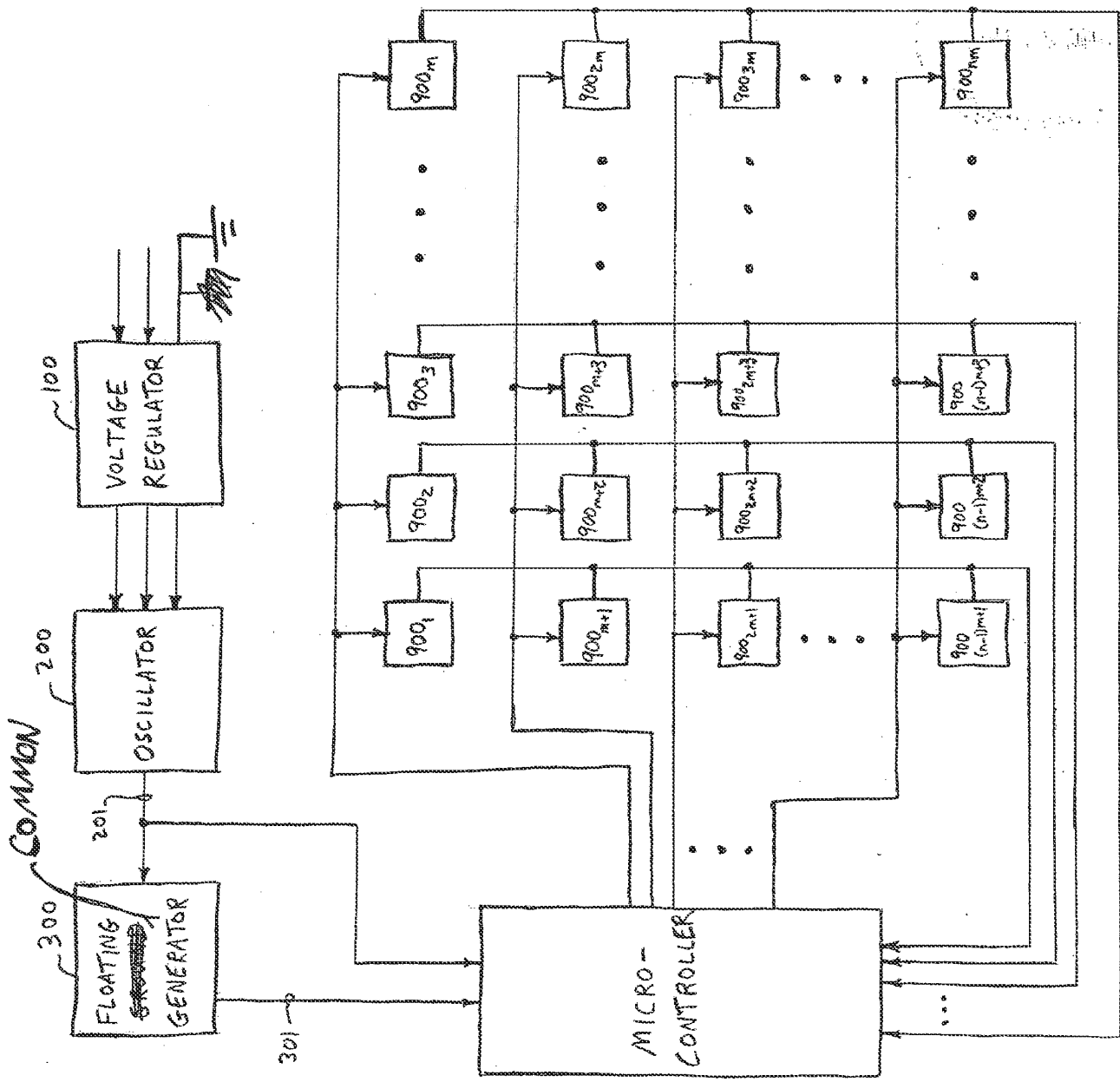

FIG. 11

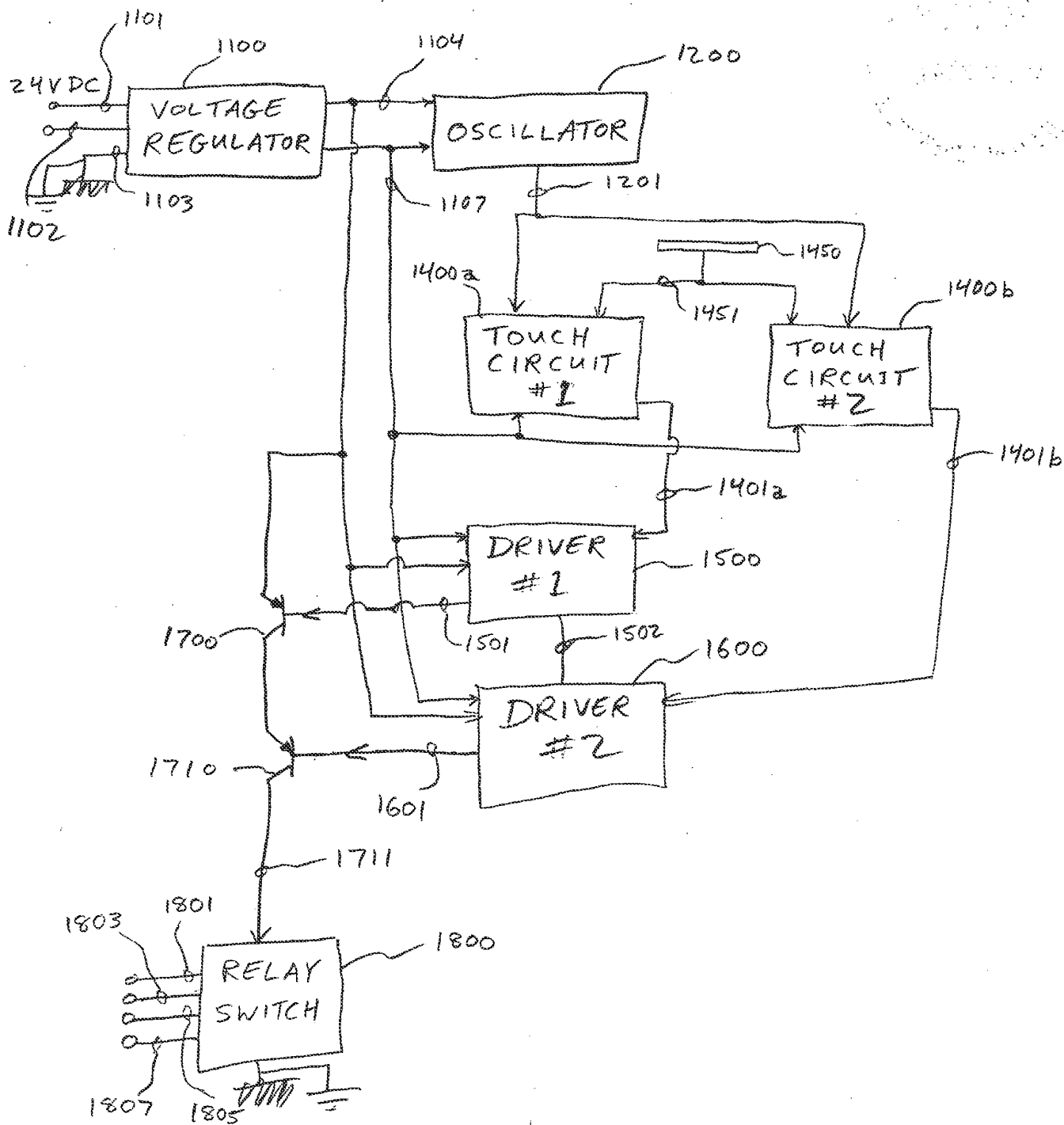

FIG. 12

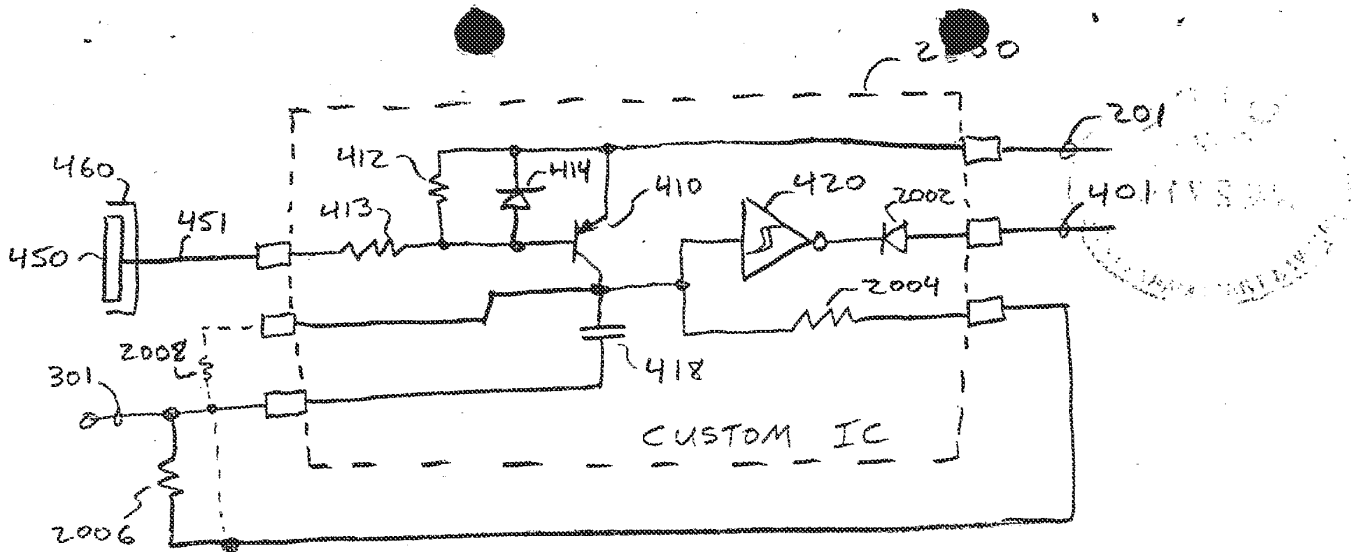

FIG. 17

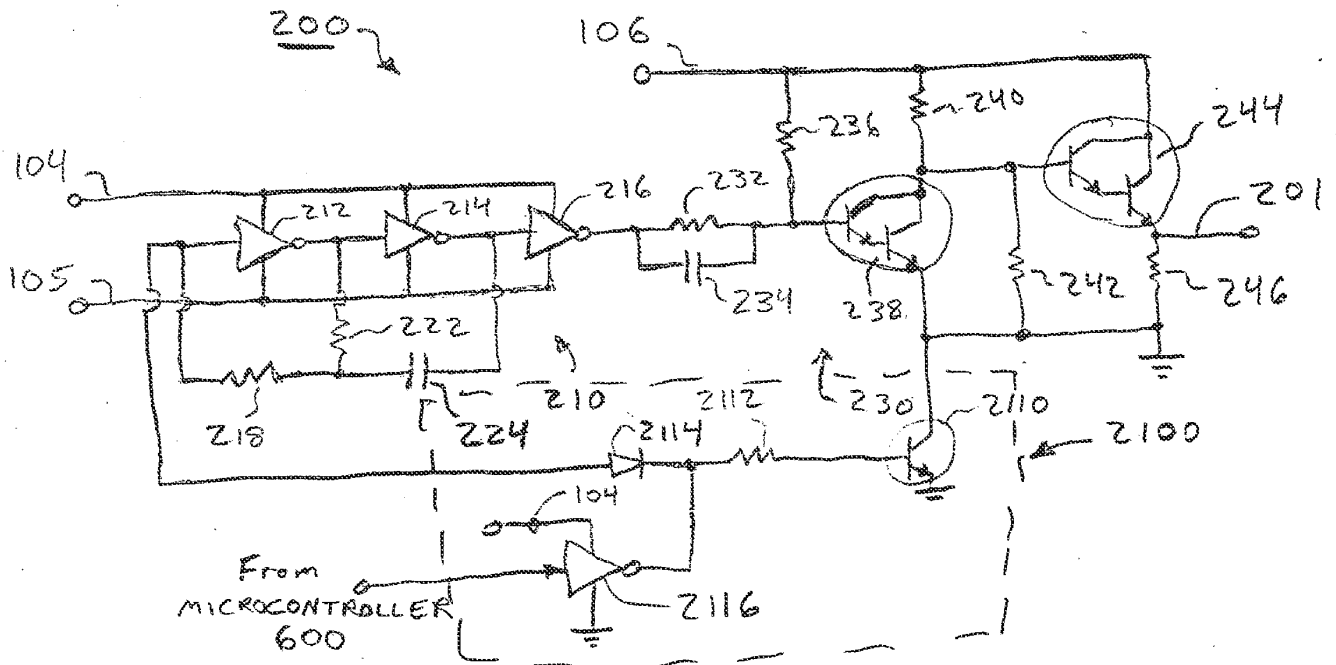
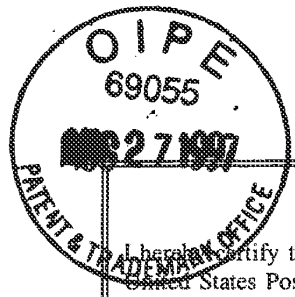

FIG. 18

GP 2107/B



Atty. Docket No. NAR01 P-310

CERTIFICATE OF MAILING

I hereby certify that this paper, together with all enclosures identified herein, are being deposited with the United States Postal Service as first class mail, addressed to the Assistant Commissioner for Patents, Washington D.C. 20231, on the date indicated below.

Date 8/22/97 *Rebecca A. Schwartz*
 Rebecca A. Schwartz

IN THE UNITED STATES PATENT AND TRADEMARK OFFICE

RECEIVED
SEP 22 1997
GROUP 2100

Art Unit : 2107
 Examiner : J. Kaplan
 Appln. No. : 08/601,268
 Filing Date : January 31, 1996
 Applicant : Byron Hourmand
 For : CAPACITIVE RESPONSIVE ELECTRONIC SWITCHING CIRCUIT

10/10/97
w/ drug. call.
Shuman
9-23-97
Shuman

Assistant Commissioner for Patents
 Washington, D.C. 20231

Dear Sir:

Enclosed is a response to the Office Action dated April 22, 1997. Also enclosed are nine sheets of corrected drawings. The items checked below are appropriate:

Applicants hereby petition for a one-month extension of time to respond to the above Office Action. The fee of \$55.00 for the Extension is enclosed.

Any fee for additional claims has been calculated as shown below:

CLAIMS AS AMENDED

	Col. 1		Col. 2		Col. 3		Small Entity		Other Than A Small Entity	
	Claims Remaining After Amendment		Highest No. Previously Paid For	Present Extra	Rate	Add'l Fee	Rate	Add'l Fee		
Total Claims	*3,250.00 OP 132.00 OP 55.00 OP	Minus	**20	=12	x \$11	\$132	x \$ 22	\$00		
Independent Claims	*08	Minus	***04	=04	x \$40	\$160	x \$ 80	\$00		
First Presentation of Multiple Dependent Claims							\$130	\$00	x \$260	\$00
TOTAL ADDITIONAL FEE FOR THIS AMENDMENT							\$292		\$00	

09/16/1997
 01 FC:202
 02 FC:203
 03 FC:215

A

Applicant : Byron Hourmand
Appln. No. : 08/601,268
Page : 2

- * If the entry in Col. 1 is less than the entry in Col. 2, write "0" in Col. 3
- ** If the "Highest No. Previously Paid For" IN THIS SPACE is less than 20, write "20" in this space.
- *** If the "Highest No. Previously Paid For" IN THIS SPACE is less than 3, write "3" in this space.
The "Highest No. Previously Paid For" (Total or Independent) is the highest number found from the equivalent box in Col. 1 of a prior amendment or the number of claims originally filed.

Small entity status of this application under 37 C.F.R. §§ 1.9 and 1.27 has been established by a verified statement previously submitted.

No additional fee is required.

A fee of \$292.00 to cover the cost of the additional claims added by this response is enclosed.

Please charge any additional fees or credit overpayment to Deposit Account 16 2463. A duplicate copy of this sheet is attached.

PRICE, HENEVELD, COOPER,
DEWITT & LITTON

8-22-97

Date

Terry S. Callaghan
Registration No. 34 559
695 Kenmoor, S.E.
Post Office Box 2567
Grand Rapids, Michigan 49501
(616) 949-9610

TSC/ras



**UNITED STATES DEPARTMENT OF COMMERCE
Patent and Trademark Office**

Address: Box ISSUE FEE
ASSISTANT COMMISSIONER FOR PATENTS
Washington, D.C. 20231

NOTICE OF ALLOWANCE AND ISSUE FEE DUE

21M1/1027

PRICE HENEVELD COOPER
DEWITT & LITTON
695 KENMOOR DRIVE SE
P O BOX 2567
GRAND RAPIDS MI 49501

12

APPLICATION NO.	FILING DATE	TOTAL CLAIMS	EXAMINER AND GROUP ART UNIT	DATE MAILED
08/601,268	01/31/96	032	KAPLAN, J	2107 10/27/97
First Named Applicant	HOURMAND, BYRON			

TITLE OF INVENTION CAPACITIVE RESPONSIVE ELECTRONIC SWITCHING CIRCUIT

ATTY'S DOCKET NO.	CLASS-SUBCLASS	BATCH NO.	APPLN. TYPE	SMALL ENTITY	FEE DUE	DATE DUE
2	NAR01-P-310	307-116.000	T51 UTILITY	YES	\$660.00	01/27/98

THE APPLICATION IDENTIFIED ABOVE HAS BEEN EXAMINED AND IS ALLOWED FOR ISSUANCE AS A PATENT. PROSECUTION ON THE MERITS IS CLOSED.

THE ISSUE FEE MUST BE PAID WITHIN THREE MONTHS FROM THE MAILING DATE OF THIS NOTICE OR THIS APPLICATION SHALL BE REGARDED AS ABANDONED. THIS STATUTORY PERIOD CANNOT BE EXTENDED.

HOW TO RESPOND TO THIS NOTICE:

- I. Review the SMALL ENTITY status shown above.
If the SMALL ENTITY is shown as YES, verify your current SMALL ENTITY status:
 - A. If the status is changed, pay twice the amount of the FEE DUE shown above and notify the Patent and Trademark Office of the change in status, or
 - B. If the status is the same, pay the FEE DUE shown above.

- If the SMALL ENTITY is shown as NO:
 - A. Pay FEE DUE shown above, or
 - B. File verified statement of Small Entity Status before, or with, payment of 1/2 the FEE DUE shown above.

II. Part B of this notice should be completed and returned to the Patent and Trademark Office (PTO) with your ISSUE FEE. Even if the ISSUE FEE has already been paid by charge to deposit account, Part B should be completed and returned. If you are charging the ISSUE FEE to your deposit account, section "6b" of Part B should be completed.

III. All communications regarding this application must give application number and batch number. Please direct all communication prior to issuance to Box ISSUE FEE unless advised to the contrary.

IMPORTANT REMINDER: Patents issuing on applications filed on or after Dec. 12, 1980 may require payment of maintenance fees. It is patentee's responsibility to ensure timely payment of maintenance fees when due.

Notice of Allowability

Application No. 08/601,268	Applicant(s) Hourmand
Examiner Jonathan Kaplan	Group Art Unit 2107



All claims being allowable, PROSECUTION ON THE MERITS IS (OR REMAINS) CLOSED in this application. If not included herewith (or previously mailed), a Notice of Allowance and Issue Fee Due or other appropriate communication will be mailed in due course.

- This communication is responsive to the amendment filed 8/27/97.
- The allowed claim(s) is/are 1-32.
- The drawings filed on _____ are acceptable.
- Acknowledgement is made of a claim for foreign priority under 35 U.S.C. § 119(a)-(d).
 - All Some* None of the CERTIFIED copies of the priority documents have been received.
 - received in Application No. (Series Code/Serial Number) _____.
 - received in this national stage application from the International Bureau (PCT Rule 17.2(a)).
- *Certified copies not received: _____
- Acknowledgement is made of a claim for domestic priority under 35 U.S.C. § 119(e).

A SHORTENED STATUTORY PERIOD FOR RESPONSE to comply with the requirements noted below is set to EXPIRE THREE MONTHS FROM THE "DATE MAILED" of this Office action. Failure to timely comply will result in ABANDONMENT of this application. Extensions of time may be obtained under the provisions of 37 CFR 1.136(a).

- Note the attached EXAMINER'S AMENDMENT or NOTICE OF INFORMAL APPLICATION, PTO-152, which discloses that the oath or declaration is deficient. A SUBSTITUTE OATH OR DECLARATION IS REQUIRED.
- Applicant MUST submit NEW FORMAL DRAWINGS
 - because the originally filed drawings were declared by applicant to be informal.
 - including changes required by the Notice of Draftsperson's Patent Drawing Review, PTO-948, attached hereto or to Paper No. 8.
 - including changes required by the proposed drawing correction filed on 8/27/97, which has been approved by the examiner.
 - including changes required by the attached Examiner's Amendment/Comment.

Identifying indicia such as the application number (see 37 CFR 1.84(c)) should be written on the reverse side of the drawings. The drawings should be filed as a separate paper with a transmittal letter addressed to the Official Draftsperson.

- Note the attached Examiner's comment regarding REQUIREMENT FOR THE DEPOSIT OF BIOLOGICAL MATERIAL.

Any response to this letter should include, in the upper right hand corner, the APPLICATION NUMBER (SERIES CODE/SERIAL NUMBER). If applicant has received a Notice of Allowance and Issue Fee Due, the ISSUE BATCH NUMBER and DATE of the NOTICE OF ALLOWANCE should also be included.

Attachment(s)

- Notice of References Cited, PTO-892
- Information Disclosure Statement(s), PTO-1449, Paper No(s) 9
- Notice of Draftsperson's Patent Drawing Review, PTO-948
- Notice of Informal Patent Application, PTO-152
- Interview Summary, PTO-413
- Examiner's Amendment/Comment
- Examiner's Comment Regarding Requirement for Deposit of Biological Material
- Examiner's Statement of Reasons for Allowance

WILLIAM M. SHOOP, JR.
SUPERVISORY PATENT EXAMINER
ART UNIT 217

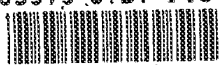

07/31/97

FORM PTO-1449 U.S. DEPARTMENT OF COMMERCE (Rev. 2-32) PATENT AND TRADEMARK OFFICE INFORMATION DISCLOSURE STATEMENT BY APPLICANT (Use several sheets if necessary)	ATTY. DOCKET NO. NAR01 P-310	SERIAL NO. 08/601,268
	APPLICANT(S) BYRON HOURMAND	
	FILING DATE 01/31/96	ART UNIT 2107

U.S. PATENT DOCUMENTS

EXAMINER INITIAL	DOCUMENT NUMBER	DATE	NAME	CLASS	SUB- CLASS	FILING DATE IF APPRO- PRIATE	
						Y	N
<i>JK</i>	5 5 7 2 2 0 5	11/05/96	Caldwell et al.	341	33		

FOREIGN PATENT DOCUMENTS

EXAMINER INITIAL	DOCUMENT NUMBER	DATE	COUNTRY	CLASS	SUB- CLASS	TRANSLA- TION	
						Y	N

OTHER DOCUMENTS (Including Author, Title, Date, Pertinent Pages, Etc.)

EXAMINER INITIAL	

EXAMINER <i>Jonathan Kaplan</i>	DATE CONSIDERED <i>10/24/97</i>
EXAMINER: Initial if citation considered, whether or not citation is in conformance with MPEP 609; Draw line through citation if not in conformance and not considered. Include copy of this form with next communication to applicant.	

4100
 5796183
 4/17/98
 307/116.000
 2811
 4/23/98
 6/2/98

Atty. Docket No. NAR01 P-310

CERTIFICATE OF MAILING

I hereby certify that this paper, together with all enclosures identified herein, are being deposited with the United States Postal Service as first class mail, addressed to the Assistant Commissioner for Patents, Box Issue Fee, Washington D.C. 20231, on the date indicated below.

11/3/97
 Date

Rebecca A. Schwartz
 Rebecca A. Schwartz

IN THE UNITED STATES PATENT AND TRADEMARK OFFICE

Art Unit : 2107
 Examiner : J. Kaplan
 Appln. No. : 08/601,268
 Filing Date : January 31, 1996
 Applicant : Byron Hourmand
 For : CAPACTIVE RESPONSIVE ELECTRONIC SWITCHING CIRCUIT
 Batch No. : T51

NOV 06 1997
 RECEIVED
 Pub. Div.

Asst. Commissioner for Patents
 Box Issue Fee
 Washington, D.C. 20231

6-19-98
 7530 Pub. Div
 PN = 5,796,183

Dear Sir:

Enter bk for 10/14/98

AMENDMENT UNDER 37 C.F.R. §1.312

Pursuant to 37 C.F.R. §1.312 and subject to the recommendation of the Examiner and the approval of the Commissioner, and without withdrawing the case from issue, kindly amend the subject application as follows.

In the Claims:

Claim 27, line 11, after "when" delete "said".

REMARKS

The above-identified application was allowed in the Office Action mailed October 27, 1997. The issue fee has not been paid. Subsequent to the receipt of the Notice of

Applicant : Byron Hourmand
Appl. No. : 08/601,268
Page : 2

Allowance, Applicant noted a typographical error in claim 27. The requested amendment is submitted to correct this error. The requested amendment is fully supported by the specification and drawings, will not require an additional search, and does not raise new issues. Therefore, Applicant respectfully requests that this amendment be entered and the requested change made.

The reference for the application within the issue branch as indicated on the Notice of Allowance, is T51. If there are any fees due in connection with the filing of this amendment, please charge the fees to our deposit account No. 16 2463.

Respectfully submitted,

BYRON HOURMAND

By: Price, Heneveld, Cooper,
DeWitt & Litton

11-3-97
Date

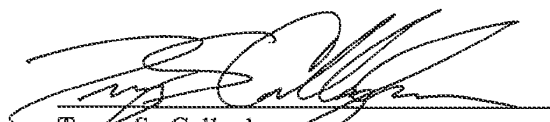
Terry S. Callaghan
Registration No. 34 559
695 Kenmoor, S.E.
Post Office Box 2567
Grand Rapids, Michigan 49501
(616) 949-9610

TSC/ras

PB

PART B—ISSUE FEE TRANSMITTAL

2,422,660
501 15

MAILING INSTRUCTIONS: This form should be used for transmitting the ISSUE FEE. Blocks 2 through 6 should be completed where appropriate. All further correspondence including the Issue Fee Receipt, the Patent, advance orders and notification of maintenance fees will be mailed to addressee entered in Block 1 unless you direct otherwise, by: (a) specifying a new correspondence address in Block 3 below; or (b) providing the PTO with a separate "FEE ADDRESS" for maintenance fee notifications with the payment of Issue Fee or thereafter. See reverse for Certificate of Mailing, below.

Under the Paperwork Reduction Act of 1995, no persons are required to respond to a collection of information unless it displays a valid OMB control number.

Burden Hour Statement: This form is estimated to take 0.2 hours to complete. Time will vary depending on the needs of the individual case. Any comments on the amount of time required to complete this form should be sent to the Chief Information Officer, Patent and Trademark Office, Washington, D.C. 20231.

DO NOT SEND FEES OR COMPLETED FORMS TO THIS ADDRESS. SEND TO: Box Issue Fee, Assistant Commissioner for Patents, Washington D.C. 20231

1. CORRESPONDENCE ADDRESS

PRICE HENEVELD COOPER
DEWITT & LITTON
695 KENMOOR DRIVE SE
P O BOX 2567
GRAND RAPIDS MI 49501

21 RECEIVED
Publishing Division
JAN 29 1998
C7

2. INVENTOR(S) ADDRESS CHANGE (Complete only if there is a change)

INVENTOR'S NAME _____

Street Address _____

City, State and ZIP Code _____

CO-INVENTOR'S NAME _____

Street Address _____

City, State and ZIP Code _____

Check if additional changes are enclosed

APPLICATION NO.	FILING DATE	TOTAL CLAIMS	EXAMINER AND GROUP ART UNIT	DATE MAILED
08/601,268	01/31/96	032	KAPLAN, J 2107	10/27/97
First Named Applicant	HOURMAND, BYRON			

TITLE OF INVENTION CAPACITIVE RESPONSIVE ELECTRONIC SWITCHING CIRCUIT

ATTY'S DOCKET NO.	CLASS-SUBCLASS	BATCH NO.	APPLN. TYPE	SMALL ENTITY	FEE DUE	DATE DUE
2	NAR01-P-310	307-116,000	T51 - UTILITY	YES	\$660.00	01/27/98

3. Correspondence address change (Complete only if there is a change)

4. For printing on the patent front page, list the names of not more than 3 registered patent attorneys or agents OR, alternatively, the name of a firm having as a member a registered attorney or agent. If no name is listed, no name will be printed.

Price, Heneveld
Cooper, DeWitt &
Litton
2 _____
3 _____

02/09/1998 CASHBY 00000148 08601268
01 FC:242 660.00 OP
02 FC:561 15.00 OP

5. ASSIGNMENT DATA TO BE PRINTED ON THE PATENT (print or type)

(1) NAME OF ASSIGNEE: Nartron Corporation
(2) ADDRESS: (CITY & STATE OR COUNTRY) Reed City, Michigan

A. This application is NOT assigned.
 Assignment previously submitted to the Patent and Trademark Office.
 Assignment is being submitted under separate cover. Assignments should be directed to Box ASSIGNMENTS.
PLEASE NOTE: Unless an assignee is identified in Block 5, no assignee data will appear on the patent. Inclusion of assignee data is only appropriate when an assignment has been previously submitted to the PTO or is being submitted under separate cover. Completion of this form is NOT a substitute for filing an assignment.

6a. The following fees are enclosed:
 Issue Fee Advance Order - # of Copies 5

6b. The following fees should be changed to:
DEPOSIT ACCOUNT NUMBER 16 2463
(ENCLOSE A COPY OF THIS FORM)
 Issue Fee Advance Order - # of Copies _____
 Any Deficiencies in Enclosed Fees

The COMMISSIONER OF PATENTS AND TRADEMARKS is requested to apply the Issue Fee to the application identified above.

(Authorized Signatory)
Perry S. Callaghan 34 559 01/26/98
NOTE: The Issue Fee will not be accepted from anyone other than the applicant, a registered attorney or agent, or the assignee or other party in interest as shown by the records of the Patent and Trademark Office.

Certificate of Mailing

Note: If this certificate of mailing is used, it can only be used to transmit the Issue Fee. This certificate cannot be used for any other accompanying papers. Each additional paper, such as an assignment or formal drawing, must have its own certificate of mailing.

I hereby certify that this correspondence is being deposited with the United States Postal Service with sufficient postage as first class mail in an envelope addressed to: Box ISSUE FEE, Assistant Commissioner for Patents, Washington, D.C. 20231

on: January 26, 1998 (Date)
Rebecca A. Schwartz (Name of person making deposit)
Rebecca A. Schwartz (Signature)
1/26/98 (Date)

1. TRANSMIT THIS FORM WITH FEE



UNITED STATES DEPARTMENT OF COMMERCE
Patent and Trademark Office

Address: COMMISSIONER OF PATENTS AND TRADEMARKS
Washington, D.C. 20231

APPLICATION NO.	FILING DATE	FIRST NAMED INVENTOR	ATTORNEY DOCKET NO.
087601,268	01/31/96	HOURMAND	B NAR01-P-310

B2M1/0304

PRICE HENEVELD COOPER
DEWITT & LITTON
695 KENMOOR DRIVE SE
P O BOX 2567
GRAND RAPIDS MI 49501

EXAMINER
KAFLAN, J

ART UNIT	PAPER NUMBER
2107	

DATE MAILED: 03/04/98

Please find below and/or attached an Office communication concerning this application or proceeding.

Commissioner of Patents and Trademarks

*Supplemental
Notice of Allowability*

Application No. 08/601,268	Applicant(s) Hourmend
Examiner Jonathan Kaplan	Group Art Unit 2107



All claims being allowable, PROSECUTION ON THE MERITS IS (OR REMAINS) CLOSED in this application. If not included herewith (or previously mailed), a Notice of Allowance and Issue Fee Due or other appropriate communication will be mailed in due course.

This communication is responsive to the letter mailed 2/3/98

The allowed claim(s) is/are 1-32

The drawings filed on _____ are acceptable.

Acknowledgement is made of a claim for foreign priority under 35 U.S.C. § 119(a)-(d).

All Some* None of the CERTIFIED copies of the priority documents have been
 received.

received in Application No. (Series Code/Serial Number) _____

received in this national stage application from the International Bureau (PCT Rule 17.2(a)).

*Certified copies not received: _____

Acknowledgement is made of a claim for domestic priority under 35 U.S.C. § 119(e).

A SHORTENED STATUTORY PERIOD FOR RESPONSE to comply with the requirements noted below is set to EXPIRE THREE MONTHS FROM THE "DATE MAILED" of this Office action. Failure to timely comply will result in ABANDONMENT of this application. Extensions of time may be obtained under the provisions of 37 CFR 1.136(a).

Note the attached EXAMINER'S AMENDMENT or NOTICE OF INFORMAL APPLICATION, PTO-152, which discloses that the oath or declaration is deficient. A SUBSTITUTE OATH OR DECLARATION IS REQUIRED.

Applicant MUST submit NEW FORMAL DRAWINGS

because the originally filed drawings were declared by applicant to be informal.

including changes required by the Notice of Draftsperson's Patent Drawing Review, PTO-948, attached hereto or to Paper No. _____

including changes required by the proposed drawing correction filed on _____, which has been approved by the examiner.

including changes required by the attached Examiner's Amendment/Comment.

Identifying indicia such as the application number (see 37 CFR 1.84(c)) should be written on the reverse side of the drawings. The drawings should be filed as a separate paper with a transmittal letter addressed to the Official Draftsperson.

Note the attached Examiner's comment regarding REQUIREMENT FOR THE DEPOSIT OF BIOLOGICAL MATERIAL.

Any response to this letter should include, in the upper right hand corner, the APPLICATION NUMBER (SERIES CODE/SERIAL NUMBER). If applicant has received a Notice of Allowance and Issue Fee Due, the ISSUE BATCH NUMBER and DATE of the NOTICE OF ALLOWANCE should also be included.

Attachment(s)

Notice of References Cited, PTO-892

Information Disclosure Statement(s), PTO-1449, Paper No(s). 5

Notice of Draftsperson's Patent Drawing Review, PTO-948

Notice of Informal Patent Application, PTO-152

Interview Summary, PTO-413

Examiner's Amendment/Comment

Examiner's Comment Regarding Requirement for Deposit of Biological Material

Examiner's Statement of Reasons for Allowance

WILLIAM M. SHOOP, JR.
SUPERVISORY PATENT EXAMINER
ART UNIT 217



Express Mail No. Rb7825787641
Sheet 1 of 2

Form PTO-1449

U.S. DEPARTMENT OF COMMERCE
PATENT AND TRADEMARK OFFICE

ATTY. DOCKET NO.

SERIAL NO.

NAR01 P-310

INFORMATION DISCLOSURE STATEMENT
BY APPLICANT

APPLICANTS

Byron Hourmand

FILING DATE

GROUP

U.S. PATENT DOCUMENTS

EXAMINER INITIAL	PATENT NUMBER								ISSUE DATE	NAME	CLASS	SUBCLASS	FILING DATE IF APPROPRIATE
	5	4	5	3	6	4	4						
AK	5	4	5	3	6	4	4	09/26/95	Yap et al.				
	5	3	8	6	2	1	9	01/31/95	Creanias et al.				
	5	2	3	5	2	1	7	08/10/93	Kirton				
	5	2	3	3	2	3	1	08/03/93	Wieth et al.				
	5	2	0	8	5	1	6	05/04/93	Saidian				
	5	0	8	7	8	2	5	02/11/92	Ingraham				
	5	0	6	6	8	9	8	11/19/91	Miller et al.				
	5	0	1	2	1	2	4	04/30/91	Hollaway				
	4	9	3	9	3	8	2	07/03/90	Gruodis				
	4	9	1	0	5	0	4	03/20/90	Eriksson				
	4	8	3	1	2	7	9	05/16/89	Ingraham				
	4	7	5	8	7	3	5	07/19/88	Ingraham				
	4	7	3	1	5	4	8	03/15/88	Ingraham				
	4	4	7	6	4	6	3	10/09/84	Ng et al.				
	4	3	7	4	3	8	1	02/15/83	Ng et al.				
	4	3	6	0	7	3	7	11/23/82	Leopold				
	4	3	2	3	8	2	9	04/06/82	Witney et al.				
	4	3	0	8	4	4	3	12/29/81	Tucker et al.				
	4	2	8	9	9	8	0	09/15/81	McLaughlin				
	4	2	8	9	9	7	2	09/15/81	Wern				
4	2	6	4	8	3	1	04/28/81	Wern					
4	2	5	7	1	1	7	03/17/81	Besson					

FOREIGN PATENT DOCUMENTS

DOCUMENT NUMBER	PUBLICATION DATE	COUNTRY	CLASS	SUBCLASS	TRANSLATION	
					YES	NO

OTHER DOCUMENTS (Including Author, Title, Date, Pertinent Pages, Etc.)

EXAMINER

Jonathan Kaplan

DATE CONSIDERED

4/11/97

EXAMINER: Initial if citation is considered, whether or not citation is in conformance with MPEP 609; Draw line through citation if not in conformance and not considered. Include copy of this form with next communication to applicant.

Express Mail No. RB782578764U

Sheet 2 of 2



Form PTO-1489

U.S. DEPARTMENT OF COMMERCE
PATENT AND TRADEMARK OFFICE

ATTY. DOCKET NO.
NAR01 P-310

SERIAL NO.

INFORMATION DISCLOSURE STATEMENT
BY APPLICANT

APPLICANTS
Byron Hourmand

FILING DATE

GROUP

U.S. PATENT DOCUMENTS

EXAMINER INITIAL	PATENT NUMBER							ISSUE DATE	NAME	CLASS	SUBCLASS	FILING DATE IF APPROPRIATE
JK	4	2	4	6	5	3	3	01/20/81	Chiang			
	4	2	3	7	4	2	1	12/02/80	Waldron			
	4	2	2	0	8	1	5	09/02/80	Gibson et al.			
	4	2	1	3	0	6	1	07/15/80	Conner			
	4	2	1	1	9	5	9	07/08/80	Deavenport et al.			
	4	2	1	0	8	2	2	07/01/80	Wern			
	4	1	5	9	4	7	3	06/26/79	Senk			
	4	1	5	2	6	2	9	05/01/79	Raupp			
	4	1	1	9	8	6	4	10/10/78	Petrizio			
	4	1	0	1	8	0	5	07/18/78	Stone			
	4	0	7	1	6	8	9	01/31/78	Talmage et al.			
	4	0	3	1	4	0	8	06/21/77	Holz			
	4	0	1	6	4	5	3	04/05/77	Moennig			
	3	9	8	4	7	5	7	10/05/76	Gott et al.			
	3	9	6	5	4	6	5	06/22/76	Alexander			
	3	9	1	9	5	9	6	11/11/75	Bellis			
	3	9	1	1	2	1	5	10/07/75	Hurst et al.			
	3	8	9	9	7	1	3	08/12/75	Barkan et al.			
	3	7	9	8	3	7	0	03/19/74	Hurst			
	3	6	6	6	9	8	8	05/30/72	Bellis			
3	6	5	1	3	9	1	03/21/72	Vogelsberg				
3	6	4	1	4	1	0	02/08/72	Vogelsberg				
3	5	4	9	9	0	9	08/25/69	Adelson et al.				

FOREIGN PATENT DOCUMENTS

DOCUMENT NUMBER	PUBLICATION DATE	COUNTRY	CLASS	SUBCLASS	TRANSLATION	
					YES	NO

OTHER DOCUMENTS (Including Author, Title, Date, Pertinent Pages, Etc.)

EXAMINER: Jonathan Kaplan

DATE CONSIDERED: 4/11/97

EXAMINER: Initial if citation is considered, whether or not citation is in conformance with MPEP 609; Draw line through citation if not in conformance and not considered. Include copy of this form with next communication to applicant.



ede \$
#17
MJ

Atty. Docket No. NAR01 P-310

CERTIFICATE OF MAILING

I hereby certify that this paper, together with all enclosures identified herein, are being deposited with the United States Postal Service as first class mail, addressed to the Assistant Commissioner for Patents, Washington D.C. 20231, on the date indicated below.

1/20/99
Date

Rebecca A. Schwartz
Rebecca A. Schwartz

IN THE UNITED STATES PATENT AND TRADEMARK OFFICE

Patentee : Byron Hourmand
Patent No. : 5,796,183
Issue Date : August 18, 1998

CERTIFICATE

FEB - 4 1999

Assistant Commissioner for Patents
Washington, D.C. 20231

CORRECTION

Dear Sir:

A request is being made for a Certificate of Correction in the above-identified patent, which issued with the following errors identified by page and line from the application file.

- * Page 11, line 9, "such a" should be --such as--.
- Page 19, line 4, before "water" insert --condensed--.
- * Page 31, line 5, "is" should be --as--.
- * Page 30, line 3, "it's" should be --its--.
- * Page 40, line 3, "references" should be --reference--.
- * Page 43, line 8, "it's" should be --its--.
- * Page 43, line 9, "it's" should be --its--.
- * Page 43, line 10, "it's" should be --its-- (all occurrences).
- * Page 43, line 12, "it's" should be --its--.
- * Page 43, line 17, "it's" should be --its--.
- * Page 44, line 8, "it's" should be --its--.
- * Page 44, line 9, "it's" should be --its--.
- * Page 44, line 13, "it's" should be --its-- (both occurrences).
- * Page 45, line 10, "it's" should be --its--.

Mary H. Deane
APR 15 1999
FOR THE COMMISSIONER OF PAT. & T.M.

01/29/1999 NABAT1 00000207 5796183

01 FC:145

100.00 OP

Patentee : Byron Hourmand
Patent No. : 5,796,183
Page : 2

- * Page 45, line 11, "it's" should be --its--.
- * Page 45, line 14, "it's" should be --its--.
- * Page 46, line 11, "it's" should be --its--.
- * Page 46, line 14, "it's" should be --its-- (both occurrences).
- * Page 46, line 19, "it's" should be --its--.
- * Page 47, line 11, "it's" should be --its--.
- * Page 47, line 15, "schmitt" should be --Schmitt--.

Page 55, claim 7 [11], line 3, after "microcontroller." delete "by an operator's body . . .
higher frequencies."

- * Amendment A, page 11, claim 18, line 12, after "electrical" insert --path--.
 - * Amendment A, page 11, claim 18, line 12, delete "path".
- 312 Amendment, page 1, claim 27, line 11, after "when" delete "said".

Enclosed is the Certificate of Correction Form PTO 1050 identifying errors by column and line from the patent which are chargeable to the Official Printer. Also enclosed is a check for \$100.00 to cover our errors, which are identified with an asterisk. The Commissioner is hereby authorized to charge any additional payment, or to credit any overpayment, to Deposit Account No. 16-2463.

Respectfully submitted,

BYRON HOURMAND

By: Price, Heneveld, Cooper,
DeWitt & Litton

1-20-99
Date

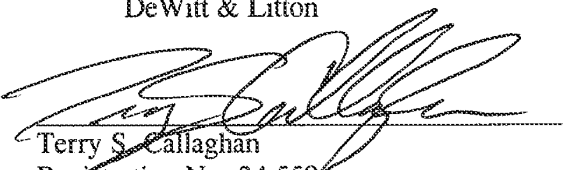
Terry S. Callaghan
Registration No. 34 559
695 Kenmoor, S.E./Post Office Box 2567
Grand Rapids, Michigan 49501
(616) 949-9610

TSC/ras

Staple
Here
Only!

UNITED STATES PATENT AND TRADEMARK OFFICE CERTIFICATE OF CORRECTION

PATENT NO. : 5,796,183
DATED : August 18, 1998
INVENTOR(S) : Byron Hourmand

It is certified that error appears in the above-identified patent and that said Letters Patent is hereby corrected as shown below:

- Column 5, line 52, "such a" should be --such as--. *a*
- Column 9, line 31, before "water" insert --condensed--. *C*
- Column 14, line 35, "is" should be --as--. *a*
- Column 13, line 65, "it's" should be --its--. *a*
- Column 18, line 38, "references" should be --reference--. *a*
- Column 20, line 7, "it's" should be --its-- (both occurrences). *a*
- Column 20, line 9, "it's" should be --its--. *a*
- Column 20, line 10, "it's" should be --its-- (both occurrences). *a*
- Column 20, line 13, "it's" should be --its--. *a*
- Column 20, line 20, "it's" should be --its--. *a*
- Column 20, line 39, "it's" should be --its--. *a*
- Column 20, line 40, "it's" should be --its--. *a*
- Column 20, line 46, "it's" should be --its--. *a*
- Column 20, line 47, "it's" should be --its--. *a*
- Column 21, line 8, "it's" should be --its--. *a*
- Column 21, line 9, "it's" should be --its--. *a*
- Column 21, line 15, "it's" should be --its--. *a*

MAILING ADDRESS OF SENDER:

Terry S. Callaghan
Price, Heneveld, Cooper,
DeWitt & Litton
Post Office Box 2567
Grand Rapids, MI 49501

PATENT NO. 5,796,183

No. of add'l copies
@ \$0.50 per page

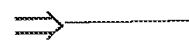

Staple
Here
Only!

UNITED STATES PATENT AND TRADEMARK OFFICE CERTIFICATE OF CORRECTION

PATENT NO. : 5,796,183
DATED : August 18, 1998
INVENTOR(S) : Byron Hourmand

It is certified that error appears in the above-identified patent and that said Letters Patent is hereby corrected as shown below:

- Column 21, line 42, "it's" should be --its--.
- Column 21, line 46, "it's" should be --its--.
- Column 21, line 47, "it's" should be --its--.
- Column 21, line 56, "it's" should be --its--.
- Column 22, line 8, "it's" should be --its--.
- Column 22, line 13, "schmitt" should be --Schmitt--.
- Column 26, lines 22-27, after "microcontroller." delete "by an operator's body . . . higher frequencies."
- Column 27, line 44, after "electrical" insert --path--.
- Column 27, line 45, delete "path".
- Column 29, line 1, after "when" delete "said".

MAILING ADDRESS OF SENDER:

Terry S. Callaghan
Price, Heneveld, Cooper,
DeWitt & Litton
Post Office Box 2567
Grand Rapids, MI 49501

PATENT NO. 5,796,183

No. of add'l copies
@ \$0.50 per page





UNITED STATES PATENT AND TRADEMARK OFFICE

Commissioner for Patents
United States Patent and Trademark Office
P.O. Box 1450
Alexandria, VA 22313-1450
www.uspto.gov

**BROOKS KUSHMAN P.C.
1000 TOWN CENTER
TWENTY-SECOND FLOOR
SOUTHFIELD, MI 48075**

MAILED

AUG 25 2011

OFFICE OF PETITIONS

In re Patent No. 5,796,183 :
Issue Date: August 18, 1998 :
Application No. 08/601,268 :
Filed: January 31, 1996 :
Attorney Docket No. :

ON PETITION

This is a decision on the petition filed August 19, 2011 under 37 CFR 1.323, which is being treated as a request under 37 CFR 1.324 to correct the name of the inventors by way of a Certificate of Correction.

The petition is **GRANTED**.

Petitioner request that the inventorship of this application be amended by the addition of **JOHN M. WASHELESKI** of Cadillac, Michigan, and **STEPHEN R. W. COOPER**, of Fowlerville, Michigan, based on the Consent Judgment dated September 8 2010 under 35 USC 256. Petitioner includes with the renewed petition an Oath having the above inventors.

The inventorship of this patent has been amended by the addition of **JOHN M. WASHELESKI** and **STEPHEN R. W. COOPER**.

Telephone inquiries concerning this decision may be directed to the undersigned at (571) 272-0602. Inquiries regarding the issuance of a certificate of correction should be directed to the Certificate of Correction Branch at (571) 272-4200.

Thurman K. Page
Petitions Examiner
Office of Petitions

Enclosure: Corrected filing receipt



UNITED STATES PATENT AND TRADEMARK OFFICE

UNITED STATES DEPARTMENT OF COMMERCE
United States Patent and Trademark Office
Address: COMMISSIONER FOR PATENTS
P.O. Box 1450
Alexandria, Virginia 22313-1450
www.uspto.gov

APPLICATION NUMBER	FILING or 371(c) DATE	GRP ART UNIT	FIL FEE REC'D	ATTY. DOCKET NO	TOT CLAIMS	IND CLAIMS
08/601,268	01/31/1996	2836	771	NAR0227L	20	4

CONFIRMATION NO. 3176

CORRECTED FILING RECEIPT



22045
BROOKS KUSHMAN P.C.
1000 TOWN CENTER
TWENTY-SECOND FLOOR
SOUTHFIELD, MI 48075

Date Mailed: 08/25/2011

Receipt is acknowledged of this non-provisional patent application. The application will be taken up for examination in due course. Applicant will be notified as to the results of the examination. Any correspondence concerning the application must include the following identification information: the U.S. APPLICATION NUMBER, FILING DATE, NAME OF APPLICANT, and TITLE OF INVENTION. Fees transmitted by check or draft are subject to collection. Please verify the accuracy of the data presented on this receipt. **If an error is noted on this Filing Receipt, please submit a written request for a Filing Receipt Correction. Please provide a copy of this Filing Receipt with the changes noted thereon. If you received a "Notice to File Missing Parts" for this application, please submit any corrections to this Filing Receipt with your reply to the Notice. When the USPTO processes the reply to the Notice, the USPTO will generate another Filing Receipt incorporating the requested corrections**

Applicant(s)

BYRON HOURMAND, HERSEY, MI;
JOHN M. WASHELESKI, Cadillac, MI;
STEPHEN R. W. COOPER, Fowlerville, MI;

Power of Attorney: The patent practitioners associated with Customer Number 22045

Domestic Priority data as claimed by applicant

Foreign Applications (You may be eligible to benefit from the Patent Prosecution Highway program at the USPTO. Please see <http://www.uspto.gov> for more information.)

If Required, Foreign Filing License Granted: 07/24/1996

The country code and number of your priority application, to be used for filing abroad under the Paris Convention, is **US 08/601,268**

Projected Publication Date: None, application is not eligible for pre-grant publication

Non-Publication Request: No

Early Publication Request: No

**** SMALL ENTITY ****

Title

CAPACITIVE RESPONSIVE ELECTRONIC SWITCHING CIRCUIT

Preliminary Class

307

PROTECTING YOUR INVENTION OUTSIDE THE UNITED STATES

Since the rights granted by a U.S. patent extend only throughout the territory of the United States and have no effect in a foreign country, an inventor who wishes patent protection in another country must apply for a patent in a specific country or in regional patent offices. Applicants may wish to consider the filing of an international application under the Patent Cooperation Treaty (PCT). An international (PCT) application generally has the same effect as a regular national patent application in each PCT-member country. The PCT process simplifies the filing of patent applications on the same invention in member countries, but **does not result** in a grant of "an international patent" and does not eliminate the need of applicants to file additional documents and fees in countries where patent protection is desired.

Almost every country has its own patent law, and a person desiring a patent in a particular country must make an application for patent in that country in accordance with its particular laws. Since the laws of many countries differ in various respects from the patent law of the United States, applicants are advised to seek guidance from specific foreign countries to ensure that patent rights are not lost prematurely.

Applicants also are advised that in the case of inventions made in the United States, the Director of the USPTO must issue a license before applicants can apply for a patent in a foreign country. The filing of a U.S. patent application serves as a request for a foreign filing license. The application's filing receipt contains further information and guidance as to the status of applicant's license for foreign filing.

Applicants may wish to consult the USPTO booklet, "General Information Concerning Patents" (specifically, the section entitled "Treaties and Foreign Patents") for more information on timeframes and deadlines for filing foreign patent applications. The guide is available either by contacting the USPTO Contact Center at 800-786-9199, or it can be viewed on the USPTO website at <http://www.uspto.gov/web/offices/pac/doc/general/index.html>.

For information on preventing theft of your intellectual property (patents, trademarks and copyrights), you may wish to consult the U.S. Government website, <http://www.stopfakes.gov>. Part of a Department of Commerce initiative, this website includes self-help "toolkits" giving innovators guidance on how to protect intellectual property in specific countries such as China, Korea and Mexico. For questions regarding patent enforcement issues, applicants may call the U.S. Government hotline at 1-866-999-HALT (1-866-999-4158).

LICENSE FOR FOREIGN FILING UNDER

Title 35, United States Code, Section 184

Title 37, Code of Federal Regulations, 5.11 & 5.15

GRANTED

The applicant has been granted a license under 35 U.S.C. 184, if the phrase "IF REQUIRED, FOREIGN FILING LICENSE GRANTED" followed by a date appears on this form. Such licenses are issued in all applications where the conditions for issuance of a license have been met, regardless of whether or not a license may be required as

set forth in 37 CFR 5.15. The scope and limitations of this license are set forth in 37 CFR 5.15(a) unless an earlier license has been issued under 37 CFR 5.15(b). The license is subject to revocation upon written notification. The date indicated is the effective date of the license, unless an earlier license of similar scope has been granted under 37 CFR 5.13 or 5.14.

This license is to be retained by the licensee and may be used at any time on or after the effective date thereof unless it is revoked. This license is automatically transferred to any related applications(s) filed under 37 CFR 1.53(d). This license is not retroactive.

The grant of a license does not in any way lessen the responsibility of a licensee for the security of the subject matter as imposed by any Government contract or the provisions of existing laws relating to espionage and the national security or the export of technical data. Licensees should apprise themselves of current regulations especially with respect to certain countries, of other agencies, particularly the Office of Defense Trade Controls, Department of State (with respect to Arms, Munitions and Implements of War (22 CFR 121-128)); the Bureau of Industry and Security, Department of Commerce (15 CFR parts 730-774); the Office of Foreign Assets Control, Department of Treasury (31 CFR Parts 500+) and the Department of Energy.

NOT GRANTED

No license under 35 U.S.C. 184 has been granted at this time, if the phrase "IF REQUIRED, FOREIGN FILING LICENSE GRANTED" DOES NOT appear on this form. Applicant may still petition for a license under 37 CFR 5.12, if a license is desired before the expiration of 6 months from the filing date of the application. If 6 months has lapsed from the filing date of this application and the licensee has not received any indication of a secrecy order under 35 U.S.C. 181, the licensee may foreign file the application pursuant to 37 CFR 5.15(b).

UNITED STATES PATENT AND TRADEMARK OFFICE
CERTIFICATE OF CORRECTION

PATENT NO. : 5,796,183
APPLICATION NO. : 08/601268
DATED : August 18, 1998
INVENTOR(S) : Byron Hourmand et al.

Page 1 of 1

It is certified that error appears in the above-identified patent and that said Letters Patent is hereby corrected as shown below:

Title Page, Item (75) Inventor, should read --(75) Inventors: Byron Hourmand,
Hersey, MI (US); John M. Washeleski, Cadillac, MI (US); Stephen R. W. Cooper,
Fowlerville, MI (US)--.

Signed and Sealed this
Eleventh Day of October, 2011

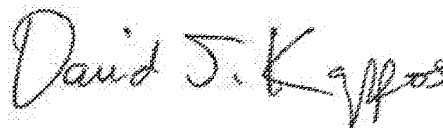
A handwritten signature in black ink that reads "David J. Kappos". The signature is written in a cursive style with a large, stylized "D" and "K".

David J. Kappos
Director of the United States Patent and Trademark Office

IN THE UNITED STATES PATENT AND TRADEMARK OFFICE

U.S. Patent No.:	5,796,183 B1	§	Docket No.:	5796183RX
Issued:	August 18, 1998	§	Inventors:	Hourmand et al.
Filed:	January 31, 1996	§	Patent Owner:	UUSI, LLC
Control No.	TBD	§	Examiner:	TBD

For: Capacitive Responsive Electronic Switching Circuit

Mail Stop *Ex Parte* Reexam
Attn: Central Reexamination Unit
Commissioner for Patents
P.O. Box 1450
Alexandria, VA 22313-1450

REQUEST FOR *EX PARTE* REEXAMINATION UNDER 35 U.S.C. §§ 302-307

Dear Sir:

Patent Owner UUSI, LLC respectfully requests *Ex Parte* Reexamination, pursuant to the provisions of 35 U.S.C. §§ 302–307 (2002), of claims 18 and 27 of United States Patent No. 5,796,183 (the “183 Patent”). This patent is still enforceable.

As set forth below, the prior art reference submitted herewith was not previously before the Office, and presents new, non-cumulative technological teachings not considered during the 183 Patent prosecution history.

I. OVERVIEW OF THE `183 PATENT AND ITS PROSECUTION HISTORY

Section II.A below provides an overview of the subject matter of the `183 Patent, while Section II.B provides an overview of its prosecution history.

A. The `183 Patent

The `183 Patent, a copy of which is provided as Exhibit A, issued on August 18, 1998 from an application filed on January 31, 1996. The `183 Patent generally relates to a capacitive responsive electronic switching circuit including an oscillator providing a periodic output signal, an input touch terminal defining an area for an operator to provide an input by proximity and touch, and a detector circuit coupled to the oscillator for receiving the periodic output signal from the oscillator, and coupled to the input touch terminal. *See, e.g.*, `183 Patent, Abstract.

The `183 Patent contains 32 total claims, with claims 1, 9, 12, 16, 18, 20, 24 and 27 being independent. Claims 18 and 27, which are the subject of this reexam request, require an oscillator, a plurality of touch terminals, and a detector circuit.

An embodiment with a single touch terminal is shown in Figure 4, and an embodiment with multiple touch terminals is shown in Figure 11, both of which are reproduced below:

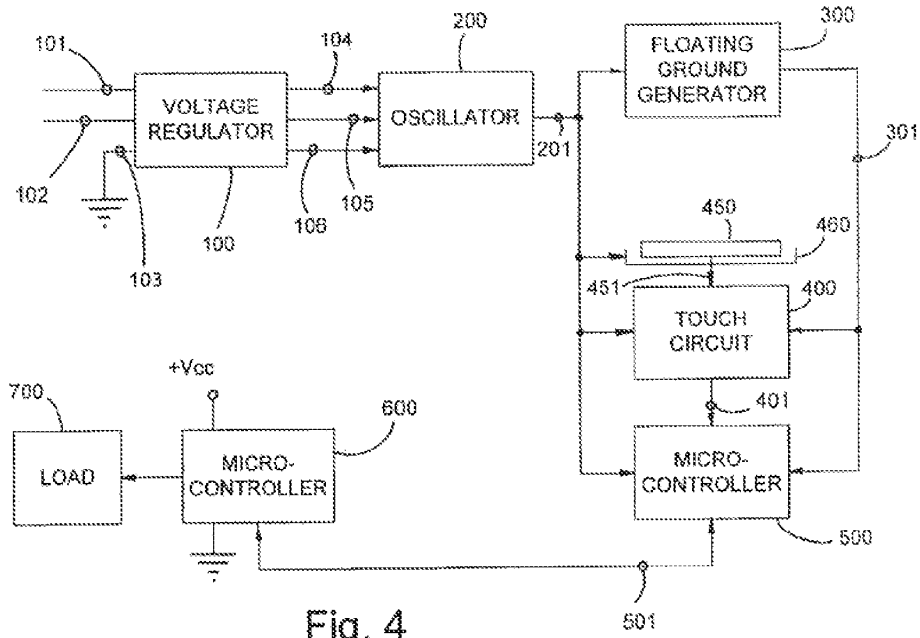

Fig. 4

Fig. 4 of the '183 Patent

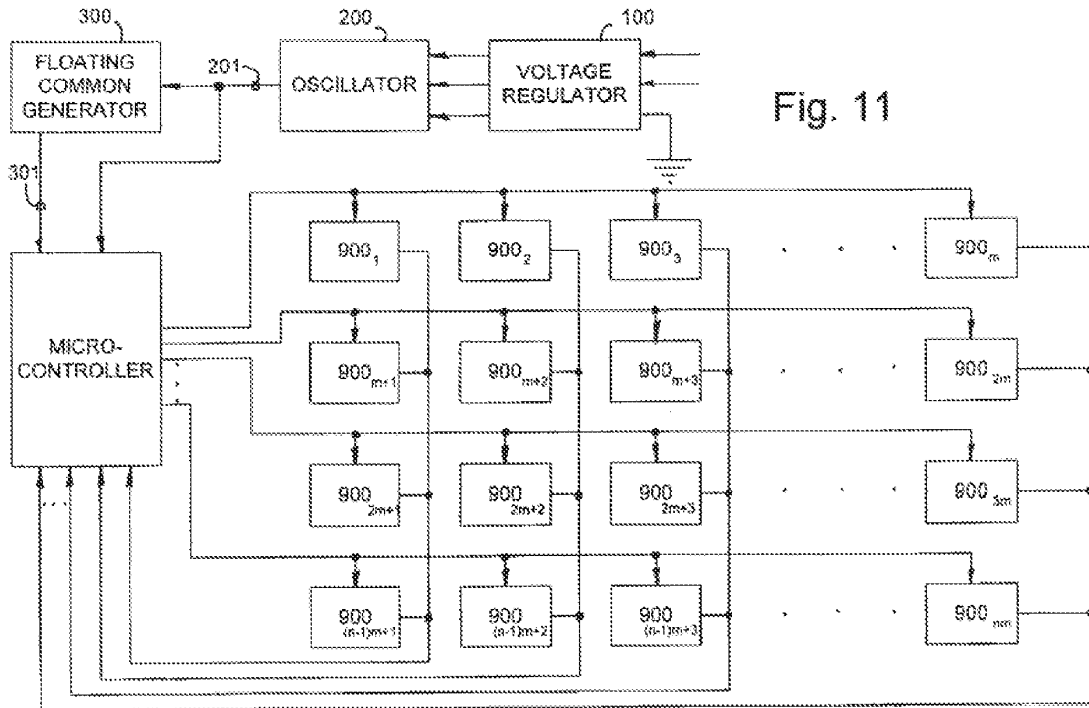

Fig. 11

Fig. 11 of the '183 Patent

The multiple touch pad circuit of Figure 11 is a variation of the embodiment shown in Figure 4, but with an array of touch circuits designated as 900₁ through 900_{nm}. *See, e.g., id.* at col. 18:34-41. The touch detection circuit offers improvements in detection sensitivity that allow close control of the degree of proximity (ideally very close proximity) that is required for actuation and to enable employment of a multiplicity of small sized touch terminals in a physically close array such as a keyboard. *See, e.g., id.* at col. 5:53-57.

Microcontroller 500 selects each row of the touch circuits 900₁ to 900_{nm} by providing the signal from oscillator 200 to selected rows of touch circuits. *See, e.g., id.* at col. 18:43-46. The values of the resistors and capacitors utilized in oscillator 200 may be varied from those disclosed above to provide for different oscillator output frequencies. *See, e.g., id.* at col. 14:22-25. Although the preferred frequency is at or above 100 kHz, and more preferably at or above 800 kHz, it is conceivable that frequencies as low as 50 kHz could be used provided the frequency creates a difference in the impedance paths of adjacent pads that is sufficient enough to accurately distinguish between an intended touch and the touch of an adjacent pad. *See, e.g., id.* at col. 11:19-25.

Microcontroller 500 sequentially activates the touch circuit rows and associates the received inputs from the columns of the array with the activated touch circuit(s). *See, e.g., id.* at col. 46-49. The detector circuit is responsive to signals from the oscillator and the presence of an operator's body capacitance to ground coupled to the touch terminal when in proximity or touched by an operator to provide a control output signal. *See, e.g., id.* at Abstract. Another method for implementing capacitive touch switches relies on the change in capacitive coupling between a touch terminal and ground. *See, e.g., id.* at col. 3:44-46.

B. The Prosecution History of the `183 Patent

A copy of selected portions of the prosecution history of the `183 Patent is provided in Exhibit B.

The `183 Patent issued from U.S. Patent Application Serial No. 08/601,268 (“the `268 application”), filed on January 31, 1996, and naming Byron Hourmand as the sole inventor. The `268 application was filed with 20 total claims, of which four were independent. Claims 21-32 were added by subsequent amendment. A cross-reference between the issued claims and the application claims from which they issued is provided below for convenience.

Issued Claim	Appl. Claim	Issued Claim	Appl. Claim	Issued Claim	Appl. Claim	Issued Claim	Appl. Claim
1	1	9	5	17	16	25	25
2	2	10	6	18	18	26	26
3	3	11	7	19	19	27	27
4	4	12	12	20	20	28	28
5	8	13	13	21	21	29	29
6	9	14	14	22	22	30	30
7	10	15	17	23	23	31	31
8	11	16	15	24	24	32	32

In an Office Action dated April 22, 1997, the Examiner rejected application claims 6, 7 and 16 under 35 U.S.C. § 112, second paragraph, as being indefinite. *See* Ex. B, `183 Patent File History, Office Action, p. 2 (Apr. 22, 1997). Claims 6, 7 and 16 would be allowable if rewritten to overcome the section 112 rejection, and to include all of the limitations of the base claim and any intervening claims. *See id.* at p. 5.

Claims 1-4 and 12-14 were rejected under 35 U.S.C. § 102(b) as being anticipated by U.S. Patent No. 4,352,141 to Kent (“Kent”). *See id.* Claims 8-11, 18, and 19 were rejected under 35 § U.S.C. 103(a) as being unpatentable over Kent in view of U.S. Patent No. 5,087,825 to Ingraham (“Ingraham”), *see id.* at p. 3, and claims 8-11, 18 and 19 were rejected under 35 U.S.C.

§ 103(a) as being unpatentable over Kent in view of U.S. Patent No. 5,235,217 to Kirton (“Kirton”). *See id.* at p. 4. Lastly, claims 5 and 15 were objected to as being dependent upon a rejected base claim, but would be allowable if rewritten in independent form including all the limitations of the base claim and any intervening claims. *See id.* at p. 5.

In response, the Applicant filed an amendment on August 22, 1997, amending claims 1, 3, 5, 6, 12-18 and 20, and adding new claims 21-32. In particular, the Applicant amended independent claim 18 as follows:

18. (Amended) A capacitive responsive electronic switching circuit comprising:
an oscillator providing a periodic output signal having a predefined frequency;
a plurality of input touch terminals defining adjacent areas on a dielectric substrate for an operator to provide inputs by proximity and touch; and
a detector circuit coupled to said oscillator for receiving said periodic output signal from said oscillator, and coupled to said input touch terminals, said detector circuit being responsive to signals from said oscillator and the presence of an operator's body capacitance to ground coupled said touch terminals when proximal or touched by an operator to provide a control output signal,
wherein said predefined frequency of said oscillator is selected to decrease the impedance of said dielectric substrate relative to the impedance of any contaminate that may create an electrical on said dielectric substrate path between said adjacent areas, and wherein said detector circuit compares the sensed body capacitance to ground proximate an input touch terminal to a threshold level to prevent inadvertent generation of the control output signal.

Ex. B, '183 Patent File History, Amendment, p. 11 (Aug. 22, 1997). The Applicant argued that the Kent and Ingraham patents both fail to teach or suggest a capacitive responsive electronic switching circuit comprising a detector circuit that compares the sensed body capacitance proximate an input touch terminal to a threshold level in order to prevent inadvertent generation of a control output signal. *See id.* at p. 19. The Applicant further argued that the Kirton patent, like the Kent and Ingraham patents, does not disclose a touch control circuit that is capable of discriminating between a full intentional touch of a touch terminal and an inadvertent touch of a portion of the surface of the touch terminal. *See id.*

With respect to new independent claim 27, the Applicant argued none of the cited references teaches or suggests a switching circuit for a control device that comprises at least first and second touch terminals and a detector circuit that generates a control output signal for actuation of the control device when an operator is proximal or touches the second touch terminal after the operator is proximal or touches the first touch terminal. *See id.* at pp. 20-21.

The Examiner issued a Notice of Allowance on October 27, 1997, allowing all of the pending claims. *See Ex. B, '183 Patent File History, Notice of Allowance, p. 2 (Oct. 27, 1997).* The Applicant then filed a section 312 amendment on November 3, 1997 to delete the word “said” after the word “when” in claim 27, line 11. *See Ex. B, '183 Patent File History, Amendment Under 37 C.F.R. § 1.312, p. 1 (Nov. 3, 1997).* The issue fee was paid on January 26, 1998, *see Ex. B, '183 Patent File History, Issue Fee Transmittal, p. 1 (Jan. 26, 1998),* and the '183 Patent subsequently issued on August 18, 1998.

The Applicant filed a certificate of correction on January 20, 1999, which was accepted by the patent office on May 11, 1999. In claim 18, the word “path” was inserted after the word “electrical” in column 27, line 44 of the '183 Patent, and the word “path” was deleted from column 27, line 45 of the '183 Patent. *See Ex. B, '183 Patent File History, Cert. of Correction, p. 3 (May 11, 1999).* In claim 27, the word “said” was deleted after the word “when.” *See id.*

The Patent Owner subsequently made several attempts to correct the inventorship of the patent, which resulted in the inventorship being changed to be Byron Hourmand, John M. Washeleski and Stephen R. W. Cooper. *See Ex. B, '183 Patent File History, Petition Decision (Aug. 25, 2011); see also Corrected Filing Receipt, p. 1 (Aug. 25, 2011); Certificate of Correction (Oct. 11, 2011).*

II. SUBSTANTIAL NEW QUESTION (“SNQ”) OF PATENTABILITY

Section III.A below provides a list of the prior art reference relied upon in the present request. Section III.B provides an overview of the prior art reference. Section III.C provides a statement regarding an SNQ of patentability for claims 18 and 27 of the `183 Patent with respect to the new reference.

|

A. Listing of Prior Art Patents and Publications

Reexamination of claims 18 and 27 of the `183 Patent is requested in view of the following reference:

Exhibit C Boie et al., U.S. Patent No. 5,463,388, filed on January 29, 1993 and issued on October 31, 1996 (“Boie `388”), which qualifies as 35 U.S.C. § 102(a)-type prior art.

B. Overview of Prior Art Patents and Publications

As discussed in more detail below, Boie`388 presents new, non-cumulative technological teachings not considered during the `183 Patent prosecution history.

1. Boie `388

Boie `388 generally relates to sensors for capacitively sensing the position or movement of an object, such as a finger, on a surface. *See, e.g.*, Boie `388, col. 1:6-8. A computer input device comprises a thin, insulating surface covering an array of electrodes arranged in a grid pattern and connected in columns and rows. *See, e.g., id.* at Abstract. Each column and row is connected to circuitry for measuring the capacitance seen by each column and row. *See, e.g., id.* The position of an object with respect to the array is determined from the centroid of such capacitance values, which is calculated in a microcontroller. *See, e.g., id.* Figure 4, reproduced below, illustrates a block diagram of a two-dimensional capacitive position sensor.

FIG. 4

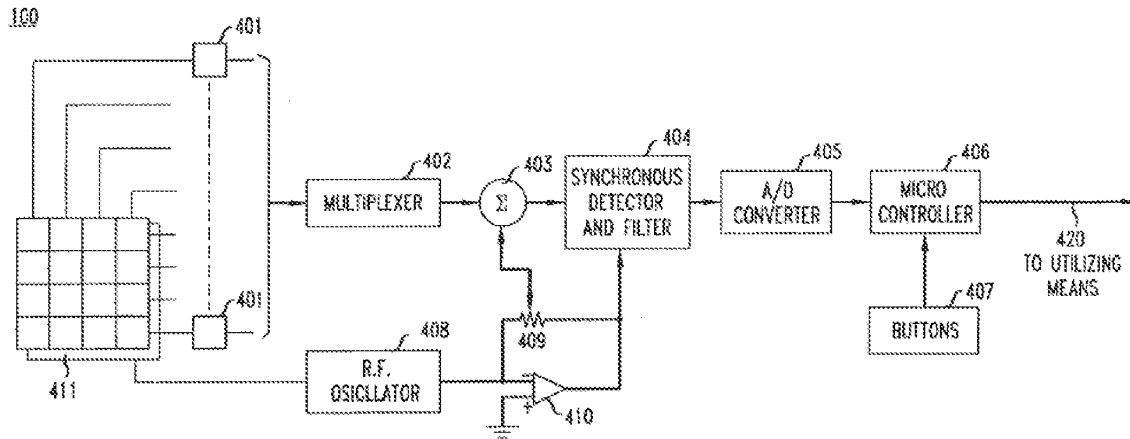

Fig. 4 of Boie '38

Each row and column of electrodes from array 100 is connected to an integrating amplifier and bootstrap circuit 401, each of which can be selected by multiplexer 402 under control of microcontroller 406. *See, e.g., Boie '388, col. 3:56-61.* The selected output is forwarded to summing circuit 403, the output of which is converted by synchronous detector and filter 404 to a signal related to the capacitance of the row or column selected by multiplexer 402. *See, e.g., id. at col. 3:62-67.* RF oscillator 408 provides an RF signal of, for example, 100 kilohertz, to circuits 401, synchronous detector and filter 404 via inverter 410, and guard plane 411, which is a substantially continuous plane parallel to array 100 and associated connections, and serves to isolate array 100 from extraneous signals. *See, e.g., id. at col. 3:67-col. 4:5.*

To measure separate capacitance values for each electrode in array 100 instead of the collective capacitances of subdivided electrode elements connected in rows and columns, a circuit 401 is provided for each electrode in array 100 and multiplexer 402 is enlarged to accommodate the outputs from all circuits 401. *See, e.g., id. at col. 4:14-21.* The output of synchronous detector and filter 404 is converted to digital form by analog-to-digital converter

405 and forwarded to microcontroller 406 so that microcontroller 406 obtains a digital value representing the capacitance seen by any row or column of electrode elements (or electrode if measured separately) selected by multiplexer 402. *See, e.g., id.* at col. 4:22-28.

C. Statement Pointing Out Each SNQ of Patentability

Boie `388 was not cited during the original patent prosecution of the `183 Patent, and presents new, non-cumulative technological teachings with respect to `183 Patent claims 18 and 27.

1. Claim 18

During the original prosecution, the Applicant amended independent claim 18 to recite “wherein said detector circuit compares the sensed body capacitance to ground proximate an input touch terminal to a threshold level to prevent inadvertent generation of the control output signal,” and argued that the cited art did not teach or suggest these limitations. After the Applicant made this amendment, the Examiner allowed claim 18.

Boie `388 discloses,

Referring to FIG. 6, microcomputer 406 reads the initial capacitance values for all the elements in array 100 and stores such values (step 601). Such initial values should reflect the state of array 100 without a finger or other object being nearby, accordingly, it may be desirable to repeat step 601 a number of times and then to select the minimum capacitance values read as the initial values, thereby compensating for the effect of any objects moving close to array 100 during the initialization step. After initialization, all capacitance values are periodically read and the initial values subtracted to yield a remainder value for each element (step 602). If one or more of the remainders exceeds a preset threshold (step 603), indicating that an object is close to or touching array 100, then the x and y coordinates of the centroid of capacitance for such object can be calculated from such remainders (step 604). . . . To avoid spurious operation, it may be desirable to require that two or more measurements exceed the preset threshold. The threshold can be set to some percentage of the range of A/D converter 405, for example 10-15% of such range.

Boie `388, col. 5:10-48; *see also id.* at Fig. 6. Boie `388 thus presents new, non-cumulative technological teachings related to the elements of claim 18 added by amendment, and such teachings were not considered in the cited art during the `183 Patent prosecution history. If the original Examiner had known of Boie `388, the Examiner likely would have considered it relevant, and likely would have cited it during the original prosecution. Boie `388 therefore raises an SNQ of patentability with respect to independent claim 18.

2. Claim 27

During the prosecution of the `183 Patent, the Applicant added independent claim 27, and argued that the cited art did not teach or suggest a detector circuit that generates a control output signal for actuation of the control device when an operator is proximal or touches the second touch terminal after the operator is proximal or touches the first touch terminal. After the Applicant added claim 27 and made this argument, the Examiner allowed claim 27.

Boie `388 discloses,

In using the position sensor of the invention as a computer mouse or trackball to control a cursor, movement of the mouse or trackball is emulated by touching array 100 with finger 102, or some other object, and stroking finger 102 over array 100 to move the cursor. Changes in position of the finger with respect to array 100 are reflected in corresponding changes in position of the cursor. Thus, for such an application, microcontroller 406 sends data over lead 420 relating to changes in position. FIG. 6 is a flow chart of the operation of microcontroller 406 in such an application.

Boie `388, col. 4:67-col. 5:9; *see also id.* at Fig. 6. Boie `388 thus presents new, non-cumulative technological teachings related to the elements of claim 27 argued by the Applicant, and such teachings were not considered in the cited art during the `183 Patent prosecution history. If the original Examiner had known of Boie `388, the Examiner likely would have considered it relevant, and likely would have cited it during the original prosecution. Boie `388 therefore raises an SNQ of patentability with respect to independent claim 27.

III. DETAILED EXPLANATION OF THE RELEVANCY AND MANNER OF APPLYING THE PRIOR ART REFERENCES TO EVERY CLAIM FOR WHICH REEXAMINATION IS REQUESTED

A detailed explanation pointing out the relevance and application of the prior art references to each of claims 18 and 27 is provided below. The charts below indicate what the Patent Owner believes are the portions of the cited art most relevant to the elements of the claims for which reexamination is requested. The Patent Owner, however, reserves the right to take positions asserting and submit arguments explaining why various claim elements are not disclosed or suggested by the cited art.

A. Claim 18

`183 Patent Claim Language	Boie `388
18. A capacitive responsive electronic switching circuit comprising:	“The capacitive sensor of the invention comprises a thin, insulating surface covering a plurality of electrodes. The position of an object, such as a finger or hand-held stylus, with respect to the electrodes, is determined from the centroid of capacitance values measured at the electrodes. . . . The x and y coordinates of the centroid are calculated in a microcontroller from the measured capacitances.” Boie `388, col. 1:61-col. 2:5, Fig. 4.
an oscillator providing a periodic output signal having a predefined frequency;	“RF oscillator 408 provides an RF signal, for example, 100 kilohertz, to circuits 401, synchronous detector and filter 404 via inverter 410, and guard plane 411.” <i>Id.</i> at col. 3:67-col. 4:2, Fig. 4.
a plurality of input touch terminals defining adjacent areas on a dielectric substrate for an operator to provide inputs by proximity and touch; and	“The operational principle of the capacitive position sensor of the invention is shown in FIG. 1. Electrode array 100 is a square or rectangular array of electrodes 101 arranged in a grid pattern of rows and columns, as in an array of tiles. . . . The electrodes are covered with a thin layer of insulating material (not shown). . . . Histogram 110 shows the capacitances for electrodes 101 in array 100 with respect to finger 102.” <i>Id.</i> at col.

`183 Patent Claim Language	Boie `388
	<p>2:49-62, Fig. 1.</p> <p>“FIG. 2 shows four such subdivided electrodes in more detail at an intersection of two rows and two columns in array 100. As can be seen from FIG. 2, a horizontal element 201 and a vertical element 202 are situated at each intersection of a row and column.” <i>Id.</i> at col. 3:16-20, Fig. 2.</p> <p>“As will be clear to those skilled in the art, elements 201 and 202 can be fabricated in one plane of a multi-layer printed circuit board together with one set of interconnections, for example, the horizontal row connections 203. The vertical row connections 204 can then be fabricated in another plane of the circuit board with appropriate via connections between the planes.” <i>Id.</i> at col. 3:30-36, Fig. 2.</p>
<p>a detector circuit coupled to said oscillator for receiving said periodic output signal from said oscillator, and coupled to said input touch terminals, said detector circuit being responsive to signals from said oscillator and the presence of an operator's body capacitance to ground coupled said touch terminals when proximal or touched by an operator to provide a control output signal,</p>	<p>“[E]ach row and column of electrodes from array 100 is connected to an integrating amplifier and bootstrap circuit 401, . . . Each of the outputs from circuits 401 can be selected by multiplexer 402 under control of microcontroller 406. The selected output is then forwarded to summing circuit 403, where such output is combined with a signal from trimmer resistor 409. Synchronous detector and filter 404 convert the output from summing circuit 403 to a signal related to the capacitance of the row or column selected by multiplexer 402. RF oscillator 408 provides an RF signal, for example, 100 kilohertz, to circuits 401, synchronous detector and filter 404 via inverter 410, and guard plane 411.” <i>Id.</i> at col. 3:53-col. 4:2, Fig. 4.</p> <p>“The output of synchronous detector and filter 404 is converted to digital form by analog-to-digital converter 405 and forwarded to microcontroller 406. Thus, microcontroller 406 can obtain a digital value representing the capacitance seen by any row or column of electrode elements (or electrode if measured</p>

`183 Patent Claim Language	Boie `388
	<p>separately) selected by multiplexer 402. . . . Microcontroller 406 sends data to utilizing means, such as a personal computer (not shown) over lead 420.” <i>Id.</i> at col. 4:21-32, Fig. 4.</p>
<p>wherein said predefined frequency of said oscillator is selected to decrease the impedance of said dielectric substrate relative to the impedance of any contaminate that may create an electrical path on said dielectric substrate between said adjacent areas, and</p> <p>wherein said detector circuit compares the sensed body capacitance to ground proximate an input touch terminal to a threshold level to prevent inadvertent generation of the control output signal.</p>	<p>“RF oscillator 408 provides an RF signal, for example, 100 kilohertz, to circuits 401, synchronous detector and filter 404 via inverter 410, and guard plane 411.” <i>Id.</i> at col. 3:67-col. 4:2, Fig. 4.</p> <p>“The effects of electrode-to-electrode capacitances, wiring capacitances and other extraneous capacitances are minimized by driving all electrodes and guard plane 411 in unison with the same RF signal from RF oscillator 408.” <i>Id.</i> at col. 4:58-61.</p> <p>“Referring to FIG. 6, microcomputer 406 reads the initial capacitance values for all the elements in array 100 and stores such values (step 601). Such initial values should reflect the state of array 100 without a finger or other object being nearby, accordingly, it may be desirable to repeat step 601 a number of times and then to select the minimum capacitance values read as the initial values, thereby compensating for the effect of any objects moving close to array 100 during the initialization step. After initialization, all capacitance values are periodically read and the initial values subtracted to yield a remainder value for each element (step 602). If one or more of the remainders exceeds a preset threshold (step 603), indicating that an object is close to or touching array 100, then the x and y coordinates of the centroid of capacitance for such object can be calculated from such remainders (step 604). . . . To avoid spurious operation, it may be desirable to require that two or more measurements exceed the preset threshold. The threshold can be set to some percentage of the range of A/D converter 405, for example 10-15% of such range.” <i>Id.</i> at col. 5:10-48, Fig. 6.</p>

B. Claim 27

`183 Patent Claim Language	Boie `388
<p>27. A capacitive responsive electronic switching circuit for a controlled device comprising:</p>	<p>“The capacitive sensor of the invention comprises a thin, insulating surface covering a plurality of electrodes. The position of an object, such as a finger or hand-held stylus, with respect to the electrodes, is determined from the centroid of capacitance values measured at the electrodes. . . . The x and y coordinates of the centroid are calculated in a microcontroller from the measured capacitances.” Boie `388, col. 1:61-col. 2:5, Fig. 4.</p> <p>“A computer input device for use as a computer mouse or keyboard comprises a thin, insulating surface covering an array of electrodes. . . . For applications in which the input device is used as a mouse, the microcontroller forwards position change information to the computer. For applications in which the input device is used as a keyboard, the microcomputer identifies a key from the position of the touching object and forwards such key identity to the computer.” <i>Id.</i> at Abstract.</p>
<p>an oscillator providing a periodic output signal having a predefined frequency;</p>	<p>“RF oscillator 408 provides an RF signal, for example, 100 kilohertz, to circuits 401, synchronous detector and filter 404 via inverter 410, and guard plane 411.” <i>Id.</i> at col. 3:67-col. 4:2, Fig. 4.</p>
<p>first and second touch terminals defining areas for an operator to provide an input by proximity and touch; and</p>	<p>“The operational principle of the capacitive position sensor of the invention is shown in FIG. 1. Electrode array 100 is a square or rectangular array of electrodes 101 arranged in a grid pattern of rows and columns, as in an array of tiles. . . . The electrodes are covered with a thin layer of insulating material (not shown). . . . Histogram 110 shows the capacitances for electrodes 101 in array 100 with respect to finger 102.” <i>Id.</i> at col. 2:49-62, Fig. 1.</p> <p>“FIG. 2 shows four such subdivided electrodes in more detail at an intersection of two rows and</p>

`183 Patent Claim Language	Boie `388
	<p>two columns in array 100. As can be seen from FIG. 2, a horizontal element 201 and a vertical element 202 are situated at each intersection of a row and column.” <i>Id.</i> at col. 3:16-20, Fig. 2.</p> <p>“As will be clear to those skilled in the art, elements 201 and 202 can be fabricated in one plane of a multi-layer printed circuit board together with one set of interconnections, for example, the horizontal row connections 203. The vertical row connections 204 can then be fabricated in another plane of the circuit board with appropriate via connections between the planes.” <i>Id.</i> at col. 3:30-36, Fig. 2.</p>
<p>a detector circuit coupled to said oscillator for receiving said periodic output signal from said oscillator, and coupled to said first and second touch terminals, said detector circuit being responsive to signals from said oscillator and the presence of an operator's body capacitance to ground coupled to said first and second touch terminals when proximal or touched by an operator to provide a control output signal for actuation of the controlled device,</p>	<p>“[E]ach row and column of electrodes from array 100 is connected to an integrating amplifier and bootstrap circuit 401, Each of the outputs from circuits 401 can be selected by multiplexer 402 under control of microcontroller 406. The selected output is then forwarded to summing circuit 403, where such output is combined with a signal from trimmer resistor 409. Synchronous detector and filter 404 convert the output from summing circuit 403 to a signal related to the capacitance of the row or column selected by multiplexer 402. RF oscillator 408 provides an RF signal, for example, 100 kilohertz, to circuits 401, synchronous detector and filter 404 via inverter 410, and guard plane 411.” <i>Id.</i> at col. 3:53-col. 4:2, Fig. 4.</p> <p>“The output of synchronous detector and filter 404 is converted to digital form by analog-to-digital converter 405 and forwarded to microcontroller 406. Thus, microcontroller 406 can obtain a digital value representing the capacitance seen by any row or column of electrode elements (or electrode if measured separately) selected by multiplexer 402. . . . Microcontroller 406 sends data to utilizing means, such as a personal computer (not shown) over lead 420.” <i>Id.</i> at col. 4:21-32, Fig. 4.</p>

`183 Patent Claim Language	Boie `388
<p>said detector circuit being configured to generate said control output signal when an operator is proximal or touches said second touch terminal after the operator is proximal or touches said first touch terminal.</p>	<p>“A computer input device for use as a computer mouse or keyboard comprises a thin, insulating surface covering an array of electrodes. . . . For applications in which the input device is used as a mouse, the microcontroller forwards position change information to the computer. For applications in which the input device is used as a keyboard, the microcomputer identifies a key from the position of the touching object and forwards such key identity to the computer.” <i>Id.</i> at Abstract.</p> <p>“In using the position sensor of the invention as a computer mouse or trackball to control a cursor, movement of the mouse or trackball is emulated by touching array 100 with finger 102, or some other object, and stroking finger 102 over array 100 to move the cursor. Changes in position of the finger with respect to array 100 are reflected in corresponding changes in position of the cursor. Thus, for such an application, microcontroller 406 sends data over lead 420 relating to changes in position. FIG. 6 is a flow chart of the operation of microcontroller 406 in such an application.” <i>Id.</i> at col. 4:67-col. 5:9, Fig. 6.</p>

IV. CONCLUSION

A substantial new question of patentability is raised based on the newly cited prior art, and therefore a reexamination of claims 18 and 27 is warranted. Again, the Patent Owner reserves the right to take positions asserting and submit arguments explaining why various claim elements are not disclosed or suggested by the cited art.

If the Office should have any questions, please contact the undersigned attorney. The Commissioner is hereby authorized to charge any fees due in connection with this filing, or credit any overpayment, to Deposit Account No. 50-1065.

Respectfully submitted,

August 17, 2012
Date

/Brian A. Carlson/
Brian A. Carlson
Reg. No. 37,793

Slater & Matsil, L.L.P.
17950 Preston Rd.
Suite 1000
Dallas, TX 75252
972-732-1001
972-732-9218 (fax)



UNITED STATES PATENT AND TRADEMARK OFFICE

UNITED STATES DEPARTMENT OF COMMERCE
United States Patent and Trademark Office
Address: COMMISSIONER FOR PATENTS
P.O. Box 1450
Alexandria, Virginia 22313-1450
www.uspto.gov

REEXAM CONTROL NUMBER	FILING OR 371 (e) DATE	PATENT NUMBER
90/012,439	08/17/2012	5796183

22045
BROOKS KUSHMAN P.C.
1000 TOWN CENTER
TWENTY-SECOND FLOOR
SOUTHFIELD, MI 48075

**CONFIRMATION NO. 4155
REEXAMINATION REQUEST
NOTICE**



Date Mailed: 08/24/2012

**NOTICE OF REEXAMINATION REQUEST FILING DATE
(Patent Owner Requester)**

Requester is hereby notified that the filing date of the request for reexamination is 08/17/2012, the date the required fee of \$2,520 was received. (See CFR 1.510(d)).

A decision on the request for reexamination will be mailed within three months from the filing date of the request for reexamination. (See 37 CFR 1.515(a)).

Pursuant to 37 CFR 1.33(c), future correspondence in this reexamination proceeding will be with the latest attorney or agent of the record in the patent file.

The paragraphs checked below are part of this communication:

- 1. The party receiving the courtesy copy is the latest attorney or agent of record in the patent file.
- 2. The person named to receive the correspondence in this proceeding has not been made the latest attorney or agent of record in the patent file because:
 - A. Requester's claim of ownership of the patent is not verified by the record.
 - B. The request papers are not signed with a real or apparent binding signature.
 - C. The mere naming of a correspondence addressee does not result in that person being appointed as the latest attorney or agent of record in the patent file.
- 3. Addressee is the latest attorney or agent of record in the patent file.
- 4. Other _____

/sdstevenson/

Legal Instruments Examiner
Central Reexamination Unit 571-272-7705; FAX No. 571-273-9900



UNITED STATES PATENT AND TRADEMARK OFFICE

UNITED STATES DEPARTMENT OF COMMERCE
United States Patent and Trademark Office
Address: COMMISSIONER FOR PATENTS
P.O. Box 1450
Alexandria, Virginia 22313-1450
www.uspto.gov

APPLICATION NO.	FILING DATE	FIRST NAMED INVENTOR	ATTORNEY DOCKET NO.	CONFIRMATION NO.
90/012,439	08/17/2012	5796183	5796183RX	4155

22045 7590 09/20/2012
BROOKS KUSHMAN P.C.
1000 TOWN CENTER
TWENTY-SECOND FLOOR
SOUTHFIELD, MI 48075

EXAMINER

NGUYEN, LINH M

ART UNIT	PAPER NUMBER
3992	

MAIL DATE	DELIVERY MODE
09/20/2012	PAPER

Please find below and/or attached an Office communication concerning this application or proceeding.

The time period for reply, if any, is set in the attached communication.

Order Granting / Denying Request For Ex Parte Reexamination	Control No.	Patent Under Reexamination
	90/012,439	5796183
	Examiner	Art Unit
	LINH M. NGUYEN	3992

--The MAILING DATE of this communication appears on the cover sheet with the correspondence address--

The request for *ex parte* reexamination filed 17 August 2012 has been considered and a determination has been made. An identification of the claims, the references relied upon, and the rationale supporting the determination are attached.

Attachments: a) PTO-892, b) PTO/SB/08, c) Other: _____

1. The request for *ex parte* reexamination is GRANTED.

RESPONSE TIMES ARE SET AS FOLLOWS:

For Patent Owner's Statement (Optional): **TWO MONTHS** from the mailing date of this communication (37 CFR 1.530 (b)). **EXTENSIONS OF TIME ARE GOVERNED BY 37 CFR 1.550(c).**

For Requester's Reply (optional): **TWO MONTHS** from the **date of service** of any timely filed Patent Owner's Statement (37 CFR 1.535). **NO EXTENSION OF THIS TIME PERIOD IS PERMITTED.** If Patent Owner does not file a timely statement under 37 CFR 1.530(b), then no reply by requester is permitted.

2. The request for *ex parte* reexamination is DENIED.

This decision is not appealable (35 U.S.C. 303(c)). Requester may seek review by petition to the Commissioner under 37 CFR 1.181 within **ONE MONTH** from the mailing date of this communication (37 CFR 1.515(c)). **EXTENSION OF TIME TO FILE SUCH A PETITION UNDER 37 CFR 1.181 ARE AVAILABLE ONLY BY PETITION TO SUSPEND OR WAIVE THE REGULATIONS UNDER 37 CFR 1.183.**

In due course, a refund under 37 CFR 1.26 (c) will be made to requester:

- a) by Treasury check or,
- b) by credit to Deposit Account No. _____, or
- c) by credit to a credit card account, unless otherwise notified (35 U.S.C. 303(c)).

--	--	--

cc: Requester (if third party requester)

DECISION

A substantial new question (SNQ) of patentability affecting claims 18 and 27 of United States Patent Number 5,796,183 ("the base patent" or "the 183' patent") is raised by the request for *ex parte* reexamination.

Information Disclosure Statement

The Information Disclosure Statement submission of August 17, 2012 has been considered. It is to be noted, however, that where patents, publications, and other such items of information are submitted by a patent owner in compliance with the requirements of the rules, **the requisite degree of consideration to be given to such information will be limited by the degree to which the patent owner has explained the content and relevance of the information.** In instances where no explanation of citations (items of information) is required and none is provided for an information citation, only a cursory review of that information is required. The examiner need only perform a cursory evaluation of each unexplained item of information, to the extent that he/she needs in order to determine whether he/she will evaluate the item further. If the cursory evaluation reveals the item not to be useful, the examiner may simply stop looking at it. This review may often take the form of considering the documents in the same manner as other documents in Office search files are considered by the examiner while conducting a search of the prior art in a proper field of search. **The initials of the examiner, in this proceeding, placed adjacent to the citations on the PTO-1449 or PTO/SB/08A and 08B or its equivalent, without an indication in the record to the contrary in the record, do not**

Art Unit: 3992

signify that the information has been considered by the examiner any further than to the extent noted above. See MPEP 609, seventh paragraph, Revision 5, Aug. 2006 [page 600-141].

References

Boie et al., U.S. Patent No. 5,463,388, filed on January 29, 1993 and issued on October 31, 1996 ("Boie '388").

Prosecution History

The base patent stems from United States Patent Application No. 08/601,268 (hereinafter "the base application").

The examiner generally agrees with the description of the prosecution history found in the Request at pp. 5-7, and that discussion is incorporated by reference. The base application was ultimately allowed without a statement of reasons for allowance. From the prosecution history, it appears likely that claims 18 and 27 were allowed in the base application because of the amendatory language in claim 18 and the new independent claim 27, as discussed at page 6-7 of the Request.

Proposed Rejections

Under 35 U.S.C. 102(a)

Claims 18 and 27 of the '183 patent are unpatentable under 35 U.S.C. § 102(a) as being anticipated by Boie '388.

Analysis of the Prior Art Provided in the Request

35 U.S.C. 102(a)

Boie '388:

It is agreed that Boie '388 raises SNQ for claims 18 and 27 of the '183 patent. Insofar as the explanation at pages 8-12 of the Request and the item-matching at page 12-17 of Claim Chart of the Request at least facially suggest that Boie '388 teaches a substantial number of claimed features. A reasonable examiner would consider that Boie '388 important in deciding whether or not claims 18 and 27 of the '183 patent are patentable. Accordingly, Boie '388 raises a substantial new question of patentability as to claims 18 and 27, which question has not been decided in a previous examination of the '306 patent.

Such teachings are not cumulative to any written discussion on the record of the teachings of the prior art, were not previously considered nor addressed during a prior examination and the same question of patentability was not the subject of a final holding of invalidity by Federal Courts.

Art Unit: 3992

Correspondence

All correspondence relating to this *ex parte* reexamination proceeding should be directed:

By Mail to: Mail Stop *Ex Parte* Reexam
Central Reexamination Unit
Commissioner for Patents
United States Patent & Trademark Office
P.O. Box 1450
Alexandria, VA 22313-1450

By FAX to: (571) 273-9900
Central Reexamination Unit

By hand: Customer Service Window
Randolph Building
401 Dulany Street
Alexandria, VA 22314

Registered users of EFS-Web may alternatively submit such correspondence via the electronic filing system EFS-Web, at <https://efs.uspto.gov/efile/myportal/efs-registered>. EFS-Web offers the benefit of quick submission to the particular area of the Office that needs to act on the correspondence. Also, EFS-Web submissions are "soft scanned" (i.e., electronically uploaded) directly into the official file for the reexamination proceeding, which offers parties the opportunity to review the content of their submissions after the "soft scanning" process is complete.

Any inquiry concerning this communication should be directed to Linh M. Nguyen at telephone number 571-272-1749.

Signed:

/Linh M. Nguyen/
Primary Examiner
Central Reexamination Unit 3992

Conferees:

/Margaret Rubin/

Primary Examiner CRU 3992

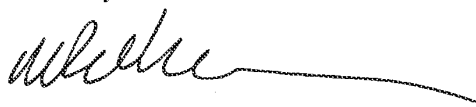
MARK J. REINHART
Supervisory Patent Reexamination Specialist
CRU -- Art Unit 3992

Electronic Acknowledgement Receipt

EFS ID:	14267867
Application Number:	90012439
International Application Number:	
Confirmation Number:	4155
Title of Invention:	Capacitive Responsive Electronic Switching Circuit
First Named Inventor/Applicant Name:	5796183
Customer Number:	25962
Filer:	Brian A. Carlson/Michelle Hatcher
Filer Authorized By:	Brian A. Carlson
Attorney Docket Number:	NAR-5796183RX
Receipt Date:	19-NOV-2012
Filing Date:	17-AUG-2012
Time Stamp:	17:13:34
Application Type:	Reexam (Patent Owner)

Payment information:

Submitted with Payment	yes
Payment Type	Deposit Account
Payment was successfully received in RAM	\$436
RAM confirmation Number	5429
Deposit Account	501065
Authorized User	

The Director of the USPTO is hereby authorized to charge indicated fees and credit any overpayment as follows:

Charge any Additional Fees required under 37 C.F.R. Section 1.16 (National application filing, search, and examination fees)

Charge any Additional Fees required under 37 C.F.R. Section 1.17 (Patent application and reexamination processing fees)

File Listing:

Document Number	Document Description	File Name	File Size(Bytes)/ Message Digest	Multi Part /.zip	Pages (if appl.)
1	Reexam Timely Patent Owner's Stmt in Resp to Order	NAR_5796183RX_PatentOwner Statement.pdf	162005 859f817488b65657299fed7faf3874996251ad6	no	37

Warnings:

Information:

2	Fee Worksheet (SB06)	fee-info.pdf	31575 49b7487f6e9985d4a57903154d3764c47396547d	no	2
---	----------------------	--------------	---	----	---

Warnings:

Information:

Total Files Size (in bytes): 193580

This Acknowledgement Receipt evidences receipt on the noted date by the USPTO of the indicated documents, characterized by the applicant, and including page counts, where applicable. It serves as evidence of receipt similar to a Post Card, as described in MPEP 503.

New Applications Under 35 U.S.C. 111

If a new application is being filed and the application includes the necessary components for a filing date (see 37 CFR 1.53(b)-(d) and MPEP 506), a Filing Receipt (37 CFR 1.54) will be issued in due course and the date shown on this Acknowledgement Receipt will establish the filing date of the application.

National Stage of an International Application under 35 U.S.C. 371

If a timely submission to enter the national stage of an international application is compliant with the conditions of 35 U.S.C. 371 and other applicable requirements a Form PCT/DO/EO/903 indicating acceptance of the application as a national stage submission under 35 U.S.C. 371 will be issued in addition to the Filing Receipt, in due course.

New International Application Filed with the USPTO as a Receiving Office

If a new international application is being filed and the international application includes the necessary components for an international filing date (see PCT Article 11 and MPEP 1810), a Notification of the International Application Number and of the International Filing Date (Form PCT/RO/105) will be issued in due course, subject to prescriptions concerning national security, and the date shown on this Acknowledgement Receipt will establish the international filing date of the application.

IN THE UNITED STATES PATENT AND TRADEMARK OFFICE

U.S. Patent No.:	5,796,183 B1	§	Docket No.:	NAR-5796183RX
Issued:	August 18, 1998	§	Inventors:	Hourmand et al.
Filed:	January 31, 1996	§	Patent Owner:	UUSI, LLC
Control No.	TBD	§	Examiner:	Nguyen, Linh M.

For: Capacitive Responsive Electronic Switching Circuit

Mail Stop *Ex Parte* Reexam
Attn: Central Reexamination Unit
Commissioner for Patents
P.O. Box 1450
Alexandria, VA 22313-1450

PATENT OWNER STATEMENT

Dear Sir:

Patent Owner respectfully submits this Patent Owner Statement in response to the September 20, 2012 Order Granting Request for *Ex Parte* Reexamination of U.S. Patent Number 5,796,183 B1 (the “183 Patent”). Patent Owner respectfully requests that the following amendments and remarks be entered, and respectfully requests consideration of amended claims 18, 27, 28 and 32, and newly-added claims 33-39.

1. Listing Of The '183 Patent Claims Under Reexamination

A listing of each claim under reexamination is provided below. Reexamination of claims 18 and 27 was granted in the Order dated September 20, 2012. Accordingly, please amend claims 18 and 27, as well claims 28 and 32, which depend from claim 27, as provided below. In addition, please add new claims 33-39 as follows.

18. (Amended) A capacitive responsive electronic switching circuit comprising:
an oscillator providing a periodic output signal having a predefined frequency;
a microcontroller using the periodic output signal from the oscillator, the microcontroller selectively providing signal output frequencies to a plurality of small sized input touch terminals of a keypad;

[a] the plurality of small sized input touch terminals defining adjacent areas on a dielectric substrate for an operator to provide inputs by proximity and touch; and

a detector circuit coupled to said oscillator for receiving said periodic output signal from said oscillator, and coupled to said input touch terminals, said detector circuit being responsive to signals from said oscillator via said microcontroller and [the] a presence of an operator's body capacitance to ground coupled to said touch terminals when proximal or touched by [an] the operator to provide a control output signal,

wherein said predefined frequency of said oscillator [is] and said signal output frequencies are selected to decrease [the] a first impedance of said dielectric substrate relative to [the] a second impedance of any contaminate that may create an electrical path on said dielectric substrate between said adjacent areas defined by the plurality of small sized input touch terminals, and wherein said detector circuit compares [the] a sensed body capacitance change to

ground proximate an input touch terminal to a threshold level to prevent inadvertent generation of the control output signal.

27. (Amended) A capacitive responsive electronic switching circuit for a controlled keypad device comprising:

an oscillator providing a periodic output signal having a predefined frequency;

a microcontroller using the periodic output signal from the oscillator, the microcontroller selectively providing signal output frequencies to a closely spaced array of input touch terminals of a keypad, the input touch terminals comprising first and second input touch terminals;

the first and second input touch terminals defining areas for an operator to provide an input by proximity and touch; and

a detector circuit coupled to said oscillator for receiving said periodic output signal from said oscillator, and coupled to said first and second touch terminals, said detector circuit being responsive to signals from said oscillator via said microcontroller and [the] a presence of an operator's body capacitance to ground coupled to said first and second touch terminals when proximal or touched by [an] the operator to provide a control output signal for actuation of the controlled keypad device, said detector circuit being configured to generate said control output signal when [an] the operator is proximal or touches said second touch terminal after the operator is proximal or touches said first touch terminal.

28. (Amended) The capacitive responsive electronic switching circuit as defined in claim 27, wherein said detector circuit generates said control signal only when [an] the operator is proximal or touches said second touch terminal within a predetermined time period after the operator is proximal or touches said first touch terminal.

32. (Amended) The capacitive responsive electronic switching circuit as defined in claim 27 and further including an indicator for indicating when said detector circuit determines that [an] the operator is proximal or touches said first touch terminal.

33. (New) The capacitive responsive electronic switching circuit as defined in claim 18, further comprising wherein said detector circuit compares the sensed body capacitance change caused by the body capacitance decreasing an input touch terminal signal on the detector to ground when proximate to the input touch terminal to a second threshold level to generate the control output signal.

34. (New) The capacitive responsive electronic switching circuit as defined in claim 18, further comprising wherein said detector circuit compares the sensed body capacitance change caused by the body capacitance decreasing an input touch terminal signal amplitude on the detector to ground when proximate to the input touch terminal to a second threshold level to generate the control output signal.

35. (New) The capacitive responsive electronic switching circuit as defined in claim 27, wherein when the second touch terminal is not touched on its defining area by the operator to provide input, the control output signal is prevented.

36. (New) The capacitive responsive electronic switching circuit as defined in claim 27 and further including an indicator for indicating when said detector circuit determines that the operator is proximal or touches said second touch terminal.

37. (New) A capacitive responsive electronic switching circuit for a controlled device

comprising:

an oscillator providing a periodic output signal having a predefined frequency, wherein an oscillator voltage is greater than a supply voltage;

a microcontroller using the periodic output signal from the oscillator, the microcontroller selectively providing signal output frequencies to a closely spaced array of input touch terminals of a keypad, the input touch terminals comprising first and second input touch terminals;

the first and second touch terminals defining areas for an operator to provide an input by proximity and touch; and

a detector circuit coupled to said oscillator for receiving said periodic output signal from said oscillator, and coupled to said first and second touch terminals, said detector circuit being responsive to signals from said oscillator via said microcontroller and a presence of an operator's body capacitance to ground coupled to said first and second touch terminals when proximal or touched by the operator to provide a control output signal for actuation of the controlled device, said detector circuit being configured to generate said control output signal when the operator is proximal or touches said second touch terminal after the operator is proximal or touches said first touch terminal.

38. (New) The capacitive responsive electronic switching circuit as defined in claim 37, wherein feedback to the operator is provided by an indicator activated by the microcontroller after the operator touches the second touch terminal.

39. (New) The capacitive responsive electronic switching circuit as defined in claim 37,

wherein said detector circuit compares a sensed body capacitance change caused by the

body capacitance decreasing a second touch terminal signal on the detector to ground when proximate to the second touch terminal to a threshold level to generate the control output signal, and

wherein feedback to the operator is provided by an indicator activated by the microcontroller after the operator touches the second touch terminal.

II. Status of the Claims

Claims 1-39 are pending in the present reexamination proceeding, of which claims 18, 27, 28 and 32 are amended herein and 33-39 are added herein.

III. Discussion of Claims and Prior Art Reference

Patent Owner filed a Request for *Ex Parte* Reexamination on August 17, 2012, submitting that a substantial new question of patentability of claims 18 and 27 is raised by Boie et al., U.S. Patent No. 5,463,388 (“Boie”). Reexamination of these claims was granted in the Order dated September 20, 2012.

Patent Owner is amending claims 18 and 27 in this Patent Owner Statement. Because some of these amendments were made to provide better antecedent basis for some claim terms, Patent Owner is amending dependent claims 28 and 32 for the same reason. Patent Owner also is adding new claims 33-39. Accordingly, Patent Owner respectfully requests consideration of amended claims 18, 27, 28 and 32, and new claims 33-39. No new matter has been added.

A. Independent Claim 18

Independent claim 18 recites “a microcontroller using the periodic output signal from the oscillator, the microcontroller selectively providing signal output frequencies to a plurality of small sized input touch terminals of a keypad.” Boie does not teach or suggest these claim elements.

Rather, Boie discloses that “RF oscillator 408 provides an RF signal, for example, 100 kilohertz, to circuits 401, synchronous detector and filter 404 via inverter 410, and guard plane 411.” Boie, col. 3:67-col. 4:2. Boie further discloses that “[t]he effects of electrode-to-electrode

capacitances, wiring capacitances and other extraneous capacitances are minimized by driving all electrodes and guard plane 411 in unison with the same RF signal from RF oscillator 408.” *Id.* at col. 4:58-60 (emphasis added); *see id.* at Fig. 4. Thus Boie discloses driving the electrodes of electrode array 100 and guard plane 411 with a single RF signal. Boie does not teach or suggest providing signal output frequencies to these components. Accordingly, Boie does not disclose all of the elements of claim 18, and therefore claim 18 is patentable over Boie.

New claims 33 and 34 depend from claim 18 and add further limitations. Patent Owner respectfully submits that these dependent claims are allowable by reason of depending from an allowable claim as well as for adding new limitations.

B. Independent Claim 27

Independent claim 27 recites “a microcontroller using the periodic output signal from the oscillator, the microcontroller selectively providing signal output frequencies to a closely spaced array of input touch terminals of a keypad, the input touch terminals comprising first and second input touch terminals.” Boie does not teach or suggest these claim elements.

Rather, Boie discloses that “RF oscillator 408 provides an RF signal, for example, 100 kilohertz, to circuits 401, synchronous detector and filter 404 via inverter 410, and guard plane 411.” Boie, col. 3:67-col. 4:2. Boie further discloses that “[t]he effects of electrode-to-electrode capacitances, wiring capacitances and other extraneous capacitances are minimized by driving all electrodes and guard plane 411 in unison with the same RF signal from RF oscillator 408.” *Id.* at col. 4:58-60 (emphasis added); *see id.* at Fig. 4. Thus Boie discloses driving the electrodes of electrode array 100 and guard plane 411 with a single RF signal. Boie does not teach or suggest

providing signal output frequencies to these components. Accordingly, Boie does not disclose all of the elements of claim 27, and therefore claim 27 is patentable over Boie.

Amended claims 28 and 32, and new claims 35-36, depend from claim 27 and add further limitations. Patent Owner respectfully submits that these dependent claims are allowable by reason of depending from an allowable claim as well as for adding new limitations.

C. Independent Claim 37

Independent claim 37 recites “a microcontroller using the periodic output signal from the oscillator, the microcontroller selectively providing signal output frequencies to a closely spaced array of input touch terminals of a keypad, the input touch terminals comprising first and second input touch terminals.” Boie does not teach or suggest these claim elements.

Rather, Boie discloses that “RF oscillator 408 provides an RF signal, for example, 100 kilohertz, to circuits 401, synchronous detector and filter 404 via inverter 410, and guard plane 411.” Boie, col. 3:67-col. 4:2. Boie further discloses that “[t]he effects of electrode-to-electrode capacitances, wiring capacitances and other extraneous capacitances are minimized by driving all electrodes and guard plane 411 in unison with the same RF signal from RF oscillator 408.” *Id.* at col. 4:58-60 (emphasis added); *see id.* at Fig. 4. Thus Boie discloses driving the electrodes of electrode array 100 and guard plane 411 with a single RF signal. Boie does not teach or suggest providing signal output frequencies to these components.

Independent claim 37 further recites “an oscillator providing a periodic output signal having a predefined frequency, wherein an oscillator voltage is greater than a supply voltage.” Boie is silent regarding an oscillator voltage being greater than a supply voltage.

For at least the above reasons, Boie does not disclose all of the elements of claim 37, and therefore claim 37 is patentable over Boie.

New claims 38-39 depend from claim 37 and add further limitations. Patent Owner respectfully submits that these dependent claims are allowable by reason of depending from an allowable claim as well as for adding new limitations.

IV. Support for Claim Amendments and New Claims

Support for each of the amendments to claims 18, 27, 28 and 32, and for new claims 33-39, may be found throughout the `183 Patent, and particular support may be found, for example, as set forth in the charts below.

A. Amended Claim 18

`183 Patent Claim Language	`183 Patent Support
18. A capacitive responsive electronic switching circuit comprising:	--
an oscillator providing a periodic output signal having a predefined frequency;	--
<u>a microcontroller using the periodic output signal from the oscillator, the microcontroller selectively providing signal output frequencies to a plurality of small sized input touch terminals of a keypad;</u>	<p>See Figures 4, 11; and Claims 8, 12, 16.</p> <p>The `183 Patent discloses “The touch detection circuit of the present invention features operation at frequencies at or above 50kHz and preferably at or above 800 kHz to minimize the effects of surface contamination for materials such a skin oils and water. It also offers improvements in detection sensitivity that allow close control of the degree of proximity (ideally very close proximity) that is required for actuation and to enable employment of a multiplicity of small size touch terminals in a physical close array such as a keyboard.” Col. 5:49-57.</p> <p>The `183 Patent discloses “In a first preferred embodiment the circuit offers enhanced detection sensitivity to allow reliable operation with small (finger size) touch pads.” Col. 6:1-3.</p> <p>The `183 Patent discloses “Although the preferred frequency is at or above 100 kHz, and more preferably at or above 800 kHz, it is conceivable that frequencies as low as 50 kHz could be used provided the frequency creates a difference in the impedance paths of adjacent pads that is sufficient enough to accurately</p>

`183 Patent Claim Language	`183 Patent Support
	<p>distinguish between an intended touch and the touch of an adjacent pad. Use of frequencies as low as 50 kHz may also be possible depending upon the type of glass or covering or the thickness thereof used for the touch pad.” Col. 11:19-27.</p> <p>The `183 Patent discloses “Upon being powered by voltage regulator 100, oscillator 200 generates a square wave with a frequency of 50 kHz, and preferably greater than 800 kHz, and having an amplitude of 26 V peak. The square wave generated by oscillator 200 is supplied via line 201 to a floating common generator 300, a touch pad shield plate 460, a touch circuit 400, and a microcontroller 500. Oscillator 200 is described below with reference to FIG. 6. Floating common generator 300 receives the 26 V peak square wave from oscillator 200 and outputs a regulated floating common that is 5 volts below the square wave output from oscillator 200 and has the same phase and frequency as the received square wave. This floating common output is supplied to touch circuit 400 and microcontroller 500 via line 301 such that the output square wave from oscillator 200 and floating common output from floating common generator 300 provide power to touch circuit 400 and microcontroller 500. Details of floating common generator 300 are discussed below with reference to FIG. 7. Touch circuit 400 senses capacitance from a touch pad 450 via line 451 and outputs a signal to microcontroller 500 via line 401 upon detecting a capacitance to ground at touch pad 450 that exceeds a threshold value. The details of touch circuit 400 are described below with reference to FIG. 8. Upon receiving an indication from touch circuit 400 that a sufficient capacitance to ground (typically at least 20 pF) is present at touch pad 450, microcontroller 500 outputs a signal to a load-controlling microcontroller 600 via line 501, which is preferably a two way optical coupling bus.” Col. 12:6-33.</p>

`183 Patent Claim Language	`183 Patent Support
	<p>The `183 Patent discloses “As will be apparent to those skilled in the art, the values of the resistors and capacitors utilized in oscillator 200 may be varied from those disclosed above to provide for different oscillator output frequencies.” Col. 14:22-25.</p> <p>The `183 Patent discloses “A multiple touch pad circuit constructed in accordance with the second embodiment is shown in FIG. 11. In the second embodiment of FIG. 11, components similar to those in the first embodiment in FIG. 4 are designated with the same references numerals and will not be discussed in detail. The multiple touch pad circuit is a variation of the first embodiment in that it includes an array of touch circuits designated as 900₁ through 900_{nm}, which, as shown, include both the touch circuit 400 shown in FIGS. 4 and 8 and the input touch terminal pad 451 (FIG. 4). Microcontroller 500 selects each row of the touch circuits 900₁ through 900_{nm} by providing the signal from oscillator 200 to selected rows of touch circuits. In this manner, microcontroller 500 can sequentially activate the touch circuit rows and associate the received inputs from the columns of the array with the activated touch circuit(s). To keep the path length 451 between the touch pad 450 and the base to the detection transistor 410 to a minimum, the detection circuits 900 are physically located directly beneath the touch pads. To simplify assembly, a flexible circuit board such as vended by Sheldahl, Inc. or Circuit Etching Technics, Inc. can be used for this purpose. Ideally, the printed circuit will be fixed directly against the surface (typically glass) bearing the conductive touch pads to eliminate air gaps and the need for conductive foam pads and spring contacts which were used to fill air gaps.” Col. 18:34-59.</p>
[a] <u>the plurality of small sized</u> input touch terminals defining adjacent	See Figure 11.

`183 Patent Claim Language	`183 Patent Support
<p>areas on a dielectric substrate for an operator to provide inputs by proximity and touch; and</p>	<p>The `183 Patent discloses “It also offers improvements in detection sensitivity that allow close control of the degree of proximity (ideally very close proximity) that is required for actuation and to enable employment of a multiplicity of small size touch terminals in a physical close array such as a keyboard.” Col. 5:53-57.</p>
<p>a detector circuit coupled to said oscillator for receiving said periodic output signal from said oscillator, and coupled to said input touch terminals, said detector circuit being responsive to signals from said oscillator <u>via said microcontroller</u> and [the] a presence of an operator's body capacitance to ground coupled <u>to</u> said touch terminals when proximal or touched by [an] <u>the</u> operator to provide a control output signal,</p>	<p>See Figures 4, 11; and Claims 8, 12, 16.</p> <p>The `183 Patent discloses The `183 Patent discloses “Upon being powered by voltage regulator 100, oscillator 200 generates a square wave with a frequency of 50 kHz, and preferably greater than 800 kHz, and having an amplitude of 26 V peak. The square wave generated by oscillator 200 is supplied via line 201 to a floating common generator 300, a touch pad shield plate 460, a touch circuit 400, and a microcontroller 500. Oscillator 200 is described below with reference to FIG. 6. Floating common generator 300 receives the 26 V peak square wave from oscillator 200 and outputs a regulated floating common that is 5 volts below the square wave output from oscillator 200 and has the same phase and frequency as the received square wave. This floating common output is supplied to touch circuit 400 and microcontroller 500 via line 301 such that the output square wave from oscillator 200 and floating common output from floating common generator 300 provide power to touch circuit 400 and microcontroller 500. Details of floating common generator 300 are discussed below with reference to FIG. 7. Touch circuit 400 senses capacitance from a touch pad 450 via line 451 and outputs a signal to microcontroller 500 via line 401 upon detecting a capacitance to ground at touch pad 450 that exceeds a threshold value. The details of touch circuit 400 are described below with reference to FIG. 8. Upon receiving an indication from touch circuit 400 that a sufficient capacitance to ground</p>

`183 Patent Claim Language	`183 Patent Support
	<p>(typically at least 20 pF) is present at touch pad 450, microcontroller 500 outputs a signal to a load-controlling microcontroller 600 via line 501, which is preferably a two way optical coupling bus.” Col. 12:6-33.</p> <p>The `183 Patent discloses “A multiple touch pad circuit constructed in accordance with the second embodiment is shown in FIG. 11. In the second embodiment of FIG. 11, components similar to those in the first embodiment in FIG. 4 are designated with the same references numerals and will not be discussed in detail. The multiple touch pad circuit is a variation of the first embodiment in that it includes an array of touch circuits designated as 9001 through 900nm, which, as shown, include both the touch circuit 400 shown in FIGS. 4 and 8 and the input touch terminal pad 451 (FIG. 4). Microcontroller 500 selects each row of the touch circuits 9001 through 900nm by providing the signal from oscillator 200 to selected rows of touch circuits. In this manner, microcontroller 500 can sequentially activate the touch circuit rows and associate the received inputs from the columns of the array with the activated touch circuit(s). To keep the path length 451 between the touch pad 450 and the base to the detection transistor 410 to a minimum, the detection circuits 900 are physically located directly beneath the touch pads. To simplify assembly, a flexible circuit board such as vended by Sheldahl, Inc. or Circuit Etching Technics, Inc. can be used for this purpose. Ideally, the printed circuit will be fixed directly against the surface (typically glass) bearing the conductive touch pads to eliminate air gaps and the need for conductive foam pads and spring contacts which were used to fill air gaps.” Col. 18:34-59.</p>
<p>wherein said predefined frequency of said oscillator [is] <u>and said signal output frequencies are</u> selected to decrease [the] <u>a first impedance of said dielectric</u></p>	<p>See Figure 11; and Claims 12, 16.</p> <p>The `183 Patent discloses “Another method for implementing capacitive touch switches relies on</p>

`183 Patent Claim Language	`183 Patent Support
<p>substrate relative to [the] <u>a second</u> impedance of any contaminate that may create an electrical path on said dielectric substrate between said adjacent areas <u>defined by the plurality of small sized input touch terminals</u>, and wherein said detector circuit compares [the] <u>a sensed body capacitance change</u> to ground proximate an input touch terminal to a threshold level to prevent inadvertent generation of the control output signal.</p>	<p>the change in capacitive coupling between a touch terminal and ground. Systems utilizing such a method are described in U.S. Pat. No. 4,758,735 and U.S. Pat. No. 5,087,825. With this methodology the detection circuit consists of an oscillator (or AC line voltage derivative) providing a signal to a touch terminal whose voltage is then monitored by a detector. The touch terminal is driven in electrical series with other components that function in part as a charge pump. The touch of an operator then provides a capacitive short to ground via the operator's own body capacitance that lowers the amplitude of oscillator voltage seen at the touch terminal." Col. 3:44-56.</p> <p>The `183 Patent discloses "The touch detection circuit of the present invention features operation at frequencies at or above 50kHz and preferably at or above 800 kHz to minimize the effects of surface contamination for materials such a skin oils and water. It also offers improvements in detection sensitivity that allow close control of the degree of proximity (ideally very close proximity) that is required for actuation and to enable employment of a multiplicity of small size touch terminals in a physical close array such as a keyboard." Col. 5:49-57.</p> <p>The `183 Patent discloses "Although the preferred frequency is at or above 100 kHz, and more preferably at or above 800 kHz, it is conceivable that frequencies as low as 50 kHz could be used provided the frequency creates a difference in the impedance paths of adjacent pads that is sufficient enough to accurately distinguish between an intended touch and the touch of an adjacent pad. Us of frequencies as low as 50 kHz may also be possible depending upon the type of glass or covering or the thickness thereof used for the touch pad." Col. 11:19-27.</p> <p>The `183 Patent discloses "As will be apparent</p>

`183 Patent Claim Language	`183 Patent Support
	to those skilled in the art, the values of the resistors and capacitors utilized in oscillator 200 may be varied from those disclosed above to provide for different oscillator output frequencies.” Col. 14:22-25.

B. Amended Claim 27

`183 Patent Claim Language	`183 Patent Support
27. A capacitive responsive electronic switching circuit for a controlled <u>keypad</u> device comprising:	<p>The `183 Patent discloses “It also offers improvements in detection sensitivity that allow close control of the degree of proximity (ideally very close proximity) that is required for actuation and to enable employment of a multiplicity of small size touch terminals in a physical close array such as a keyboard,” Col. 5:53-57.</p> <p>The `183 Patent discloses “In a first preferred embodiment the circuit offers enhanced detection sensitivity to allow reliable operation with small (finger size) touch pads.” Col. 6:1-3.</p>
an oscillator providing a periodic output signal having a predefined frequency;	---
<u>a microcontroller using the periodic output signal from the oscillator, the microcontroller selectively providing signal output frequencies to a closely spaced array of input touch terminals of a keypad, the input touch terminals comprising first and second input touch terminals;</u>	<p>See Figures 4, 11; and Claims 8, 12, 16.</p> <p>The `183 Patent discloses “The touch detection circuit of the present invention features operation at frequencies at or above 50kHz and preferably at or above 800 kHz to minimize the effects of surface contamination for materials such a skin oils and water. It also offers improvements in detection sensitivity that allow close control of the degree of proximity (ideally very close proximity) that is required for actuation and to enable employment of a multiplicity of small size touch terminals in a physical close array such as a keyboard.” Col. 5:49-57.</p>

`183 Patent Claim Language	`183 Patent Support
	<p>The `183 Patent discloses “In a first preferred embodiment the circuit offers enhanced detection sensitivity to allow reliable operation with small (finger size) touch pads.” Col. 6:1-3.</p> <p>The `183 Patent discloses “Although the preferred frequency is at or above 100 kHz, and more preferably at or above 800 kHz, it is conceivable that frequencies as low as 50 kHz could be used provided the frequency creates a difference in the impedance paths of adjacent pads that is sufficient enough to accurately distinguish between an intended touch and the touch of an adjacent pad. Us of frequencies as low as 50 kHz may also be possible depending upon the type of glass or covering or the thickness thereof used for the touch pad.” Col. 11:19-27.</p> <p>The `183 Patent discloses “Upon being powered by voltage regulator 100, oscillator 200 generates a square wave with a frequency of 50 kHz, and preferably greater than 800 kHz, and having an amplitude of 26 V peak. The square wave generated by oscillator 200 is supplied via line 201 to a floating common generator 300, a touch pad shield plate 460, a touch circuit 400, and a microcontroller 500. Oscillator 200 is described below with reference to FIG. 6. Floating common generator 300 receives the 26 V peak square wave from oscillator 200 and outputs a regulated floating common that is 5 volts below the square wave output from oscillator 200 and has the same phase and frequency as the received square wave. This floating common output is supplied to touch circuit 400 and microcontroller 500 via line 301 such that the output square wave from oscillator 200 and floating common output from floating common generator 300 provide power to touch circuit 400 and microcontroller 500. Details of floating common generator 300 are discussed below with reference to FIG. 7. Touch circuit</p>

`183 Patent Claim Language	`183 Patent Support
	<p>400 senses capacitance from a touch pad 450 via line 451 and outputs a signal to microcontroller 500 via line 401 upon detecting a capacitance to ground at touch pad 450 that exceeds a threshold value. The details of touch circuit 400 are described below with reference to FIG. 8.</p> <p>Upon receiving an indication from touch circuit 400 that a sufficient capacitance to ground (typically at least 20 pF) is present at touch pad 450, microcontroller 500 outputs a signal to a load-controlling microcontroller 600 via line 501, which is preferably a two way optical coupling bus.” Col. 12:6-33.</p> <p>The `183 Patent discloses “As will be apparent to those skilled in the art, the values of the resistors and capacitors utilized in oscillator 200 may be varied from those disclosed above to provide for different oscillator output frequencies.” Col. 14:22-25.</p> <p>The `183 Patent discloses “A multiple touch pad circuit constructed in accordance with the second embodiment is shown in FIG. 11. In the second embodiment of FIG. 11, components similar to those in the first embodiment in FIG. 4 are designated with the same references numerals and will not be discussed in detail. The multiple touch pad circuit is a variation of the first embodiment in that it includes an array of touch circuits designated as 9001 through 900n, which, as shown, include both the touch circuit 400 shown in FIGS. 4 and 8 and the input touch terminal pad 451 (FIG. 4). Microcontroller 500 selects each row of the touch circuits 9001 through 900n by providing the signal from oscillator 200 to selected rows of touch circuits. In this manner, microcontroller 500 can sequentially activate the touch circuit rows and associate the received inputs from the columns of the array with the activated touch circuit(s). To keep the path length 451 between the touch pad 450 and the base to the detection transistor 410 to a minimum, the detection circuits 900 are</p>

`183 Patent Claim Language	`183 Patent Support
	<p>physically located directly beneath the touch pads. To simplify assembly, a flexible circuit board such as vended by Sheldahl, Inc. or Circuit Etching Technics, Inc. can be used for this purpose. Ideally, the printed circuit will be fixed directly against the surface (typically glass) bearing the conductive touch pads to eliminate air gaps and the need for conductive foam pads and spring contacts which were used to fill air gaps.” Col. 18:34-59.</p>
<p><u>the</u> first and second <u>input</u> touch terminals defining areas for an operator to provide an input by proximity and touch; and</p>	<p>See Figure 11.</p> <p>The `183 Patent discloses “A multiple touch pad circuit constructed in accordance with the second embodiment is shown in FIG. 11. In the second embodiment of FIG. 11, components similar to those in the first embodiment in FIG. 4 are designated with the same references numerals and will not be discussed in detail. The multiple touch pad circuit is a variation of the first embodiment in that it includes an array of touch circuits designated as 9001 through 900nm, which, as shown, include both the touch circuit 400 shown in FIGS. 4 and 8 and the input touch terminal pad 451 (FIG. 4).” Col. 18:34-43.</p>
<p>a detector circuit coupled to said oscillator for receiving said periodic output signal from said oscillator, and coupled to said first and second touch terminals, said detector circuit being responsive to signals from said oscillator <u>via said microcontroller</u> and [the] a presence of an operator's body capacitance to ground coupled to said first and second touch terminals when proximal or touched by [an] <u>the</u> operator to provide a control output signal for actuation of the controlled <u>keypad</u> device, said detector circuit being configured to generate said control output signal when [an] <u>the</u> operator is proximal or touches said second touch terminal after the operator is</p>	<p>See Figures 4, 11; and Claims 8, 12, 16.</p> <p>The `183 Patent discloses “It also offers improvements in detection sensitivity that allow close control of the degree of proximity (ideally very close proximity) that is required for actuation and to enable employment of a multiplicity of small size touch terminals in a physical close array such as a keyboard,” Col. 5:53-57.</p> <p>The `183 Patent discloses “In a first preferred embodiment the circuit offers enhanced detection sensitivity to allow reliable operation with small (finger size) touch pads.” Col. 6:1-3.</p> <p>The `183 Patent discloses “Upon being powered</p>

`183 Patent Claim Language	`183 Patent Support
<p>proximal or touches said first touch terminal.</p>	<p>by voltage regulator 100, oscillator 200 generates a square wave with a frequency of 50 kHz, and preferably greater than 800 kHz, and having an amplitude of 26 V peak. The square wave generated by oscillator 200 is supplied via line 201 to a floating common generator 300, a touch pad shield plate 460, a touch circuit 400, and a microcontroller 500. Oscillator 200 is described below with reference to FIG. 6. Floating common generator 300 receives the 26 V peak square wave from oscillator 200 and outputs a regulated floating common that is 5 volts below the square wave output from oscillator 200 and has the same phase and frequency as the received square wave. This floating common output is supplied to touch circuit 400 and microcontroller 500 via line 301 such that the output square wave from oscillator 200 and floating common output from floating common generator 300 provide power to touch circuit 400 and microcontroller 500. Details of floating common generator 300 are discussed below with reference to FIG. 7. Touch circuit 400 senses capacitance from a touch pad 450 via line 451 and outputs a signal to microcontroller 500 via line 401 upon detecting a capacitance to ground at touch pad 450 that exceeds a threshold value. The details of touch circuit 400 are described below with reference to FIG. 8. Upon receiving an indication from touch circuit 400 that a sufficient capacitance to ground (typically at least 20 pF) is present at touch pad 450, microcontroller 500 outputs a signal to a load-controlling microcontroller 600 via line 501, which is preferably a two way optical coupling bus.” Col. 12:6-33.</p> <p>The `183 Patent discloses “A multiple touch pad circuit constructed in accordance with the second embodiment is shown in FIG. 11. In the second embodiment of FIG. 11, components similar to those in the first embodiment in FIG. 4 are designated with the same references numerals and will not be discussed in detail. The multiple</p>

`183 Patent Claim Language	`183 Patent Support
	<p>touch pad circuit is a variation of the first embodiment in that it includes an array of touch circuits designated as 9001 through 900nm, which, as shown, include both the touch circuit 400 shown in FIGS. 4 and 8 and the input touch terminal pad 451 (FIG. 4). Microcontroller 500 selects each row of the touch circuits 9001 through 900nm by providing the signal from oscillator 200 to selected rows of touch circuits. In this manner, microcontroller 500 can sequentially activate the touch circuit rows and associate the received inputs from the columns of the array with the activated touch circuit(s). To keep the path length 451 between the touch pad 450 and the base to the detection transistor 410 to a minimum, the detection circuits 900 are physically located directly beneath the touch pads. To simplify assembly, a flexible circuit board such as vended by Sheldahl, Inc. or Circuit Etching Technics, Inc. can be used for this purpose. Ideally, the printed circuit will be fixed directly against the surface (typically glass) bearing the conductive touch pads to eliminate air gaps and the need for conductive foam pads and spring contacts which were used to fill air gaps." Col. 18:34-59.</p>

C. Amended Claim 28

`183 Patent Claim Language	`183 Patent Support
<p>28. The capacitive responsive electronic switching circuit as defined in claim 27, wherein said detector circuit generates said control signal only when [an] <u>the</u> operator is proximal or touches said second touch terminal within a predetermined time period after the operator is proximal or touches said first touch terminal.</p>	<p>The amendment does not substantively change original claim 28.</p>

D. Amended Claim 32

`183 Patent Claim Language	`183 Patent Support
<p>32. The capacitive responsive electronic switching circuit as defined in claim 27 and further including an indicator for indicating when said detector circuit determines that [an] <u>the</u> operator is proximal or touches said first touch terminal.</p>	<p>The amendment does not substantively change original claim 32.</p>

E. New Claim 33

`183 Patent Claim Language	`183 Patent Support
<p>33. The capacitive responsive electronic switching circuit as defined in claim 18, further comprising wherein said detector circuit compares the sensed body capacitance change caused by the body capacitance decreasing an input touch terminal signal on the detector to ground when proximate to the input touch terminal to a second threshold level to generate the control output signal.</p>	<p>See Claims 1, 18, 28.</p> <p>The `183 Patent discloses “The touch detection circuit of the present invention features operation at frequencies at or above 50kHz and preferably at or above 800 kHz to minimize the effects of surface contamination for materials such a skin oils and water. It also offers improvements in detection sensitivity that allow close control of the degree of proximity (ideally very close proximity) that is required for actuation and to enable employment of a multiplicity of small size touch terminals in a physical close array such as a keyboard.” Col. 5:49-57.</p> <p>The `183 Patent discloses “Touch circuit 400 senses capacitance from a touch pad 450 via line 451 and outputs a signal to microcontroller 500 via line 401 upon detecting a capacitance to ground at touch pad 450 that exceeds a threshold value. The details of touch circuit 400 are described below with reference to FIG. 8.” Col. 12:24-28.</p>

F. New Claim 34

`183 Patent Claim Language	`183 Patent Support
<p>34. The capacitive responsive electronic switching circuit as defined in claim 18, further comprising wherein said detector circuit compares the sensed body capacitance change caused by the body capacitance decreasing an input touch terminal signal amplitude on the detector to ground when proximate to the input touch terminal to a second threshold level to generate the control output signal.</p>	<p>See Claims 1, 18, 28.</p> <p>The `183 Patent discloses “Another method for implementing capacitive touch switches relies on the change in capacitive coupling between a touch terminal and ground. Systems utilizing such a method are described in U.S. Pat. No. 4,758,735 and U.S. Pat. No. 5,087,825. With this methodology the detection circuit consists of an oscillator (or AC line voltage derivative) providing a signal to a touch terminal whose voltage is then monitored by a detector. The touch terminal is driven in electrical series with other components that function in part as a charge pump. The touch of an operator then provides a capacitive short to ground via the operator's own body capacitance that lowers the amplitude of oscillator voltage seen at the touch terminal.” Col. 3:44-56.</p> <p>The `183 Patent discloses “The touch detection circuit of the present invention features operation at frequencies at or above 50kHz and preferably at or above 800 kHz to minimize the effects of surface contamination for materials such a skin oils and water. It also offers improvements in detection sensitivity that allow close control of the degree of proximity (ideally very close proximity) that is required for actuation and to enable employment of a multiplicity of small size touch terminals in a physical close array such as a keyboard.” Col. 5:49-57.</p> <p>The `183 Patent discloses “Touch circuit 400 senses capacitance from a touch pad 450 via line 451 and outputs a signal to microcontroller 500 via line 401 upon detecting a capacitance to ground at touch pad 450 that exceeds a threshold value. The details of touch circuit 400 are described below with reference to FIG. 8.” Col. 12:24-28.</p>

G. New Claim 35

`183 Patent Claim Language	`183 Patent Support
<p>35. The capacitive responsive electronic switching circuit as defined in claim 27, wherein when the second touch terminal is not touched on its defining area by the operator to provide input, the control output signal is prevented.</p>	<p>See Figures 19, 20A-C; and Claim 28.</p> <p>The `183 Patent discloses “In another embodiment a method to prevent inadvertent so actuations is to require a multi-step process. Referring to FIG. 19, a device is shown having a first palm button 2201, a second palm button 2202, and an indicator light 2205. Palm button 2201 has to be activated first and then button 2202 has to be activated within a 2 second time window before a desired actuation can occur.” Col. 22:49-55.</p> <p>The `183 Patent discloses “In a variation of the multi-step process, two touch plates within a housing (one vertical and one horizontal) are used to provide a two-step turn-on. Referring to FIGS. 20A-C, the first step to actuate the output relay 2310, is initiated when the operator inserts his hands and touches the vertical touch sensor 2301 with the dorsal side of the hands. A yellow LED 2304 on top of the device show the successful completion of the first step. The second step is to flip the hand over and touch the horizontal touch sensor 2302 with the palmar side of the hand. A red LED 2305 on top of the device shows the completion of the two step turn-on and activation of output relay 2310. The flipping action of the hand in the second step causes the forearm muscles to flex, thereby reducing stiffness and fatigue. Also, the hands, and arms can rest on the run bar until the machine cycle is complete. The second step of the two-step turn-on must occur within some predetermined time (for example 2 seconds) after the release of vertical touch sensor or the first step must be repeated.” Col. 23:19-36.</p>

H. New Claim 36

`183 Patent Claim Language	`183 Patent Support
<p>36. The capacitive responsive electronic switching circuit as defined in claim 27 and further including an indicator for indicating when said detector circuit determines that the operator is proximal or touches said second touch terminal.</p>	<p>See Claim 32.</p> <p>The `183 Patent discloses “The microprocessor also allows the use of visual indicators such as LEDs or annunciators such as a bell or tone generator to confirm the actuation of a given touch switch or switches. This is particularly useful in cases where a sequence of actuations is required before an action occurs. The feedback to the operator provided by a visual or audio indicator activated by the microprocessor in response to intermediate touches in a required sequence can minimize time lost and/or frustration on the part of the operator due to failed actuations from partial touches or wrong actuations from touching the wrong pad in a given required sequence or combination of touches.” Col. 6:31-42.</p> <p>The `183 Patent discloses “A further option is to provide one or more LEDs 2205 or audible annunciators for visual or audible feedback to the operator. Specifically, in FIG. 19 the LED 2205 will come on when button 2201 has been successfully activated to cue the operator that it is time to move to button 2202. Where required a second LED with a different color than the first (yellow for the first LED and red for the second) can be provided to provide visual confirmation that the second button 2202 has been activated or that the required combination of the two buttons has been activated. Two different audible tone or sound generators could also be used in lieu of the LEDs to provide feedback to the operator.” Col. 23:1-12.</p> <p>The `183 Patent discloses “A red LED 2305 on top of the device shows the completion of the two step tum-on and activation of output relay 2310.” Col. 23:28-30.</p>

I. New Claim 37

For ease of analysis, new independent claim 37 is shown below with pseudo-amendments illustrating the differences between new claim 37 and original claim 27 of the '183 Patent.

'183 Patent Claim Language	'183 Patent Support
37. A capacitive responsive electronic switching circuit for a controlled device comprising:	See Claim 27.
<p>an oscillator providing a periodic output signal having a predefined frequency, <u>wherein an oscillator voltage is greater than a supply voltage;</u></p>	<p>See Figures 4, 5; and Claim 27.</p> <p>The '183 Patent discloses "Having provided a basis for the use of higher frequencies the basic construction of the electronic switching circuit constructed in accordance with a first embodiment of the present invention is now described with reference to FIG. 4. The electronic switching circuit includes a voltage regulator 100 including input lines 101 and 102 for receiving a 24 V AC line voltage and a line 103 for grounding the circuit. Voltage regulator 100 converts the received AC voltage to a DC voltage and supplies a regulated 5 V DC power to an oscillator 200 via lines 104 and 105. Voltage regulator also supplies oscillator 200 with 26 V DC power via line 106. The details of voltage regulator 100 are discussed below with reference to FIG. 5." Col. 11:60-Col. 12:5.</p> <p>The '183 Patent discloses "A preferred circuit for implementing a voltage regulator 100 is shown in FIG. 5. Voltage regulator 100 preferably includes an AC/DC convertor 110 for generating 29 V to 36 V unregulated DC on line 119. This unregulated DC power is supplied to a 5 V DC regulator 120 and to a 26 V DC regulator 130. AC/DC convertor 110 includes diodes 112, 114, 116, and 118, which rectify the supplied 24 V AC power provided on power lines 101 and 102." Col. 12:50-57; see also Col. 12:58-Col. 13:31.</p> <p>The '183 Patent discloses "The oscillator</p>

`183 Patent Claim Language	`183 Patent Support
	<p>circuitry shown in FIG. 6 is very stable over the temperature range of -40° C. to 105° C. The output of the touch switch circuitry drops at a rate of approximately 40 mV/°C when temperature falls below 0° C. If application requires operation at low temperatures (-40° C.) the following three methods may be used to increase the output of the switch: increase the oscillator's regulated supply voltage, increase the resistance of resistor 416, and use a 40 higher gain transistor 410. All of these methods would increase sensitivity at high temperatures." Col. 16:33-41.</p>
<p><u>a microcontroller using the periodic output signal from the oscillator, the microcontroller selectively providing signal output frequencies to a closely spaced array of input touch terminals of a keypad, the input touch terminals comprising first and second input touch terminals;</u></p>	<p>See Figures 4, 11; and Claims 8, 12, 16, 27.</p> <p>The `183 Patent discloses "The touch detection circuit of the present invention features operation at frequencies at or above 50kHz and preferably at or above 800 kHz to minimize the effects of surface contamination for materials such a skin oils and water. It also offers improvements in detection sensitivity that allow close control of the degree of proximity (ideally very close proximity) that is required for actuation and to enable employment of a multiplicity of small size touch terminals in a physical close array such as a keyboard." Col. 5:49-57.</p> <p>The `183 Patent discloses "In a first preferred embodiment the circuit offers enhanced detection sensitivity to allow reliable operation with small (finger size) touch pads." Col. 6:1-3.</p> <p>The `183 Patent discloses "Although the preferred frequency is at or above 100 kHz, and more preferably at or above 800 kHz, it is conceivable that frequencies as low as 50 kHz could be used provided the frequency creates a difference in the impedance paths of adjacent pads that is sufficient enough to accurately distinguish between an intended touch and the touch of an adjacent pad. Us of frequencies as low as 50 kHz may also be possible depending</p>

`183 Patent Claim Language	`183 Patent Support
	<p>upon the type of glass or covering or the thickness thereof used for the touch pad.” Col. 11:19-27.</p> <p>The `183 Patent discloses “Upon being powered by voltage regulator 100, oscillator 200 generates a square wave with a frequency of 50 kHz, and preferably greater than 800 kHz, and having an amplitude of 26 V peak. The square wave generated by oscillator 200 is supplied via line 201 to a floating common generator 300, a touch pad shield plate 460, a touch circuit 400, and a microcontroller 500. Oscillator 200 is described below with reference to FIG. 6. Floating common generator 300 receives the 26 V peak square wave from oscillator 200 and outputs a regulated floating common that is 5 volts below the square wave output from oscillator 200 and has the same phase and frequency as the received square wave. This floating common output is supplied to touch circuit 400 and microcontroller 500 via line 301 such that the output square wave from oscillator 200 and floating common output from floating common generator 300 provide power to touch circuit 400 and microcontroller 500. Details of floating common generator 300 are discussed below with reference to FIG. 7. Touch circuit 400 senses capacitance from a touch pad 450 via line 451 and outputs a signal to microcontroller 500 via line 401 upon detecting a capacitance to ground at touch pad 450 that exceeds a threshold value. The details of touch circuit 400 are described below with reference to FIG. 8. Upon receiving an indication from touch circuit 400 that a sufficient capacitance to ground (typically at least 20 pF) is present at touch pad 450, microcontroller 500 outputs a signal to a load-controlling microcontroller 600 via line 501, which is preferably a two way optical coupling bus.” Col. 12:6-33.</p> <p>The `183 Patent discloses “As will be apparent to those skilled in the art, the values of the</p>

`183 Patent Claim Language	`183 Patent Support
	<p>resistors and capacitors utilized in oscillator 200 may be varied from those disclosed above to provide for different oscillator output frequencies.” Col. 14:22-25.</p> <p>The `183 Patent discloses “A multiple touch pad circuit constructed in accordance with the second embodiment is shown in FIG. 11. In the second embodiment of FIG. 11, components similar to those in the first embodiment in FIG. 4 are designated with the same references numerals and will not be discussed in detail. The multiple touch pad circuit is a variation of the first embodiment in that it includes an array of touch circuits designated as 9001 through 900n, which, as shown, include both the touch circuit 400 shown in FIGS. 4 and 8 and the input touch terminal pad 451 (FIG. 4). Microcontroller 500 selects each row of the touch circuits 9001 through 900n by providing the signal from oscillator 200 to selected rows of touch circuits. In this manner, microcontroller 500 can sequentially activate the touch circuit rows and associate the received inputs from the columns of the array with the activated touch circuit(s). To keep the path length 451 between the touch pad 450 and the base to the detection transistor 410 to a minimum, the detection circuits 900 are physically located directly beneath the touch pads. To simplify assembly, a flexible circuit board such as vended by Sheldahl, Inc. or Circuit Etching Technics, Inc. can be used for this purpose. Ideally, the printed circuit will be fixed directly against the surface (typically glass) bearing the conductive touch pads to eliminate air gaps and the need for conductive foam pads and spring contacts which were used to fill air gaps.” Col. 18:34-59.</p>
<p><u>the</u> first and second touch terminals defining areas for an operator to provide an input by proximity and touch; and</p>	<p>See Claim 27.</p>

`183 Patent Claim Language	`183 Patent Support
<p>a detector circuit coupled to said oscillator for receiving said periodic output signal from said oscillator, and coupled to said first and second touch terminals, said detector circuit being responsive to signals from said oscillator via said microcontroller and [the] a presence of an operator's body capacitance to ground coupled to said first and second touch terminals when proximal or touched by [an] the operator to provide a control output signal for actuation of the controlled device, said detector circuit being configured to generate said control output signal when [an] the operator is proximal or touches said second touch terminal after the operator is proximal or touches said first touch terminal.</p>	<p>See Figures 4, 11; and Claims 8, 12, 16, 27.</p> <p>The `183 Patent discloses "Upon being powered by voltage regulator 100, oscillator 200 generates a square wave with a frequency of 50 kHz, and preferably greater than 800 kHz, and having an amplitude of 26 V peak. The square wave generated by oscillator 200 is supplied via line 201 to a floating common generator 300, a touch pad shield plate 460, a touch circuit 400, and a microcontroller 500. Oscillator 200 is described below with reference to FIG. 6. Floating common generator 300 receives the 26 V peak square wave from oscillator 200 and outputs a regulated floating common that is 5 volts below the square wave output from oscillator 200 and has the same phase and frequency as the received square wave. This floating common output is supplied to touch circuit 400 and microcontroller 500 via line 301 such that the output square wave from oscillator 200 and floating common output from floating common generator 300 provide power to touch circuit 400 and microcontroller 500. Details of floating common generator 300 are discussed below with reference to FIG. 7. Touch circuit 400 senses capacitance from a touch pad 450 via line 451 and outputs a signal to microcontroller 500 via line 401 upon detecting a capacitance to ground at touch pad 450 that exceeds a threshold value. The details of touch circuit 400 are described below with reference to FIG. 8. Upon receiving an indication from touch circuit 400 that a sufficient capacitance to ground (typically at least 20 pF) is present at touch pad 450, microcontroller 500 outputs a signal to a load-controlling microcontroller 600 via line 501, which is preferably a two way optical coupling bus." Col. 12:6-33.</p> <p>The `183 Patent discloses "A multiple touch pad circuit constructed in accordance with the second embodiment is shown in FIG. 11. In the second embodiment of FIG. 11, components similar to</p>

`183 Patent Claim Language	`183 Patent Support
	<p>those in the first embodiment in FIG. 4 are designated with the same references numerals and will not be discussed in detail. The multiple touch pad circuit is a variation of the first embodiment in that it includes an array of touch circuits designated as 9001 through 900nm, which, as shown, include both the touch circuit 400 shown in FIGS. 4 and 8 and the input touch terminal pad 451 (FIG. 4). Microcontroller 500 selects each row of the touch circuits 9001 through 900nm by providing the signal from oscillator 200 to selected rows of touch circuits. In this manner, microcontroller 500 can sequentially activate the touch circuit rows and associate the received inputs from the columns of the array with the activated touch circuit(s). To keep the path length 451 between the touch pad 450 and the base to the detection transistor 410 to a minimum, the detection circuits 900 are physically located directly beneath the touch pads. To simplify assembly, a flexible circuit board such as vended by Sheldahl, Inc. or Circuit Etching Technics, Inc. can be used for this purpose. Ideally, the printed circuit will be fixed directly against the surface (typically glass) bearing the conductive touch pads to eliminate air gaps and the need for conductive foam pads and spring contacts which were used to fill air gaps.” Col. 18:34-59.</p>

J. New Claim 38

`183 Patent Claim Language	`183 Patent Support
<p>38. The capacitive responsive electronic switching circuit as defined in claim 37, wherein feedback to the operator is provided by an indicator activated by the microcontroller after the operator touches the second touch terminal.</p>	<p>See Claims 27, 32.</p> <p>The `183 Patent discloses “The microprocessor also allows the use of visual indicators such as LEDs or annunciators such as a bell or tone generator to confirm the actuation of a given touch switch or switches. This is particularly useful in cases where a sequence of actuations is required before an action occurs. The feedback</p>

`183 Patent Claim Language	`183 Patent Support
	<p>to the operator provided by a visual or audio indicator activated by the microprocessor in response to intermediate touches in a required sequence can minimize time lost and/or frustration on the part of the operator due to failed actuations from partial touches or wrong actuations from touching the wrong pad in a given required sequence or combination of touches.” Col. 6:31-42.</p> <p>The `183 Patent discloses “A further option is to provide one or more LEDs 2205 or audible annunciators for visual or audible feedback to the operator. Specifically, in FIG. 19 the LED 2205 will come on when button 2201 has been successfully activated to cue the operator that it is time to move to button 2202. Where required a second LED with a different color than the first (yellow for the first LED and red for the second) can be provided to provide visual confirmation that the second button 2202 has been activated or that the required combination of the two buttons has been activated. Two different audible tone or sound generators could also be used in lieu of the LEDs to provide feedback to the operator.” Col. 23:1-12.</p> <p>The `183 Patent discloses “A red LED 2305 on top of the device shows the completion of the two step tum-on and activation of output relay 2310.” Col. 23:28-30.</p>

K. New Claim 39

`183 Patent Claim Language	`183 Patent Support
39. The capacitive responsive electronic switching circuit as defined in claim 37,	Claim 27.
wherein said detector circuit compares a sensed body capacitance change caused by the body capacitance	See Figure 11; and Claims 1, 12, 16, 18, 27, 28. The `183 Patent discloses “Another method for

`183 Patent Claim Language	`183 Patent Support
<p>decreasing a second touch terminal signal on the detector to ground when proximate to the second touch terminal to a threshold level to generate the control output signal, and</p>	<p>implementing capacitive touch switches relies on the change in capacitive coupling between a touch terminal and ground. Systems utilizing such a method are described in U.S. Pat. No. 4,758,735 and U.S. Pat. No. 5,087,825. With this methodology the detection circuit consists of an oscillator (or AC line voltage derivative) providing a signal to a touch terminal whose voltage is then monitored by a detector. The touch terminal is driven in electrical series with other components that function in part as a charge pump. The touch of an operator then provides a capacitive short to ground via the operator's own body capacitance that lowers the amplitude of oscillator voltage seen at the touch terminal." Col. 3:44-56.</p> <p>The `183 Patent discloses "The touch detection circuit of the present invention features operation at frequencies at or above 50kHz and preferably at or above 800 kHz to minimize the effects of surface contamination for materials such a skin oils and water. It also offers improvements in detection sensitivity that allow close control of the degree of proximity (ideally very close proximity) that is required for actuation and to enable employment of a multiplicity of small size touch terminals in a physical close array such as a keyboard." Col. 5:49-57.</p> <p>The `183 Patent discloses "Although the preferred frequency is at or above 100 kHz, and more preferably at or above 800 kHz, it is conceivable that frequencies as low as 50 kHz could be used provided the frequency creates a difference in the impedance paths of adjacent pads that is sufficient enough to accurately distinguish between an intended touch and the touch of an adjacent pad. Us of frequencies as low as 50 kHz may also be possible depending upon the type of glass or covering or the thickness thereof used for the touch pad." Col. 11:19-27.</p>

`183 Patent Claim Language	`183 Patent Support
	<p>The `183 Patent discloses “Touch circuit 400 senses capacitance from a touch pad 450 via line 451 and outputs a signal to microcontroller 500 via line 401 upon detecting a capacitance to ground at touch pad 450 that exceeds a threshold value. The details of touch circuit 400 are described below with reference to FIG. 8.” Col. 12:24-28.</p> <p>The `183 Patent discloses “As will be apparent to those skilled in the art, the values of the resistors and capacitors utilized in oscillator 200 may be varied from those disclosed above to provide for different oscillator output frequencies.” Col. 14:22-25.</p>
<p>wherein feedback to the operator is provided by an indicator activated by the microcontroller after the operator touches the second touch terminal.</p>	<p>See Claims 27, 32.</p> <p>The `183 Patent discloses “The microprocessor also allows the use of visual indicators such as LEDs or annunciators such as a bell or tone generator to confirm the actuation of a given touch switch or switches. This is particularly useful in cases where a sequence of actuations is required before an action occurs. The feedback to the operator provided by a visual or audio indicator activated by the microprocessor in response to intermediate touches in a required sequence can minimize time lost and/or frustration on the part of the operator due to failed actuations from partial touches or wrong actuations from touching the wrong pad in a given required sequence or combination of touches.” Col. 6:31-42.</p> <p>The `183 Patent discloses “A further option is to provide one or more LEDs 2205 or audible annunciators for visual or audible feedback to the operator. Specifically, in FIG. 19 the LED 2205 will come on when button 2201 has been successfully activated to cue the operator that it is time to move to button 2202. Where required a second LED with a different color than the first (yellow for the first LED and red for the second)</p>

`183 Patent Claim Language	`183 Patent Support
	<p>can be provided to provide visual confirmation that the second button 2202 has been activated or that the required combination of the two buttons has been activated. Two different audible tone or sound generators could also be used in lieu of the LEDs to provide feedback to the operator.” Col. 23:1-12.</p> <p>The `183 Patent discloses “A red LED 2305 on top of the device shows the completion of the two step tum-on and activation of output relay 2310.” Col. 23:28-30.</p>

V. Conclusion

In view of the above, Patent Owner submits that the claims are in condition for allowance. No new matter has been added by this submission. If Examiner should have any questions, please contact Patent Owner's Attorney, Brian A. Carlson, at 972-732-1001. The Commissioner is hereby authorized to charge any fees due in connection with this filing, or credit any overpayment, to Deposit Account No. 50-1065.

Respectfully submitted,

November 19, 2012
Date

/Brian A. Carlson/
Brian A. Carlson
Attorney for Patent Owner
Reg. No. 37,793

SLATER & MATSIL, L.L.P.
17950 Preston Rd., Suite 1000
Dallas, Texas 75252
Tel.: 972-732-1001
Fax: 972-732-9218



UNITED STATES PATENT AND TRADEMARK OFFICE

UNITED STATES DEPARTMENT OF COMMERCE
United States Patent and Trademark Office
Address: COMMISSIONER FOR PATENTS
P.O. Box 1450
Alexandria, Virginia 22313-1450
www.uspto.gov

APPLICATION NO.	FILING DATE	FIRST NAMED INVENTOR	ATTORNEY DOCKET NO.	CONFIRMATION NO.
-----------------	-------------	----------------------	---------------------	------------------

90/012,439	08/17/2012	5796183	NAR-5796183RX	4155
------------	------------	---------	---------------	------

25962 7590 04/10/2013
 SLATER & MATSIL, L.L.P.
 17950 PRESTON RD, SUITE 1000
 DALLAS, TX 75252-5793

EXAMINER

NGUYEN, LINH M

ART UNIT	PAPER NUMBER
----------	--------------

3992

MAIL DATE	DELIVERY MODE
-----------	---------------

04/10/2013

PAPER

Please find below and/or attached an Office communication concerning this application or proceeding.

The time period for reply, if any, is set in the attached communication.

**Notice of Intent to Issue
Ex Parte Reexamination Certificate**

Control No. 90/012,439	Patent Under Reexamination 5796183
Examiner LINH M. NGUYEN	Art Unit 3992

-- The MAILING DATE of this communication appears on the cover sheet with the correspondence address --

1. Prosecution on the merits is (or remains) closed in this *ex parte* reexamination proceeding. This proceeding is subject to reopening at the initiative of the Office or upon petition. Cf. 37 CFR 1.313(a). A Certificate will be issued in view of
 - (a) Patent owner's communication(s) filed: 19 November 2012.
 - (b) Patent owner's failure to file an appropriate timely response to the Office action mailed: _____.
 - (c) Patent owner's failure to timely file an Appeal Brief (37 CFR 41.31).
 - (d) The decision on appeal by the Board of Patent Appeals and Interferences Court dated _____.
 - (e) Other: _____.
2. The Reexamination Certificate will indicate the following:
 - (a) Change in the Specification: Yes No
 - (b) Change in the Drawing(s): Yes No
 - (c) Status of the Claim(s):
 - (1) Patent claim(s) confirmed: _____.
 - (2) Patent claim(s) amended (including dependent on amended claim(s)): 18,27,28 and 32
 - (3) Patent claim(s) canceled: _____.
 - (4) Newly presented claim(s) patentable: 33-39.
 - (5) Newly presented canceled claims: _____.
 - (6) Patent claim(s) previously currently disclaimed: _____.
 - (7) Patent claim(s) not subject to reexamination: 1-17, 19-26 and 29-31.
3. Note the attached statement of reasons for patentability and/or confirmation. Any comments considered necessary by patent owner regarding reasons for patentability and/or confirmation must be submitted promptly to avoid processing delays. Such submission(s) should be labeled: "Comments On Statement of Reasons for Patentability and/or Confirmation."
4. Note attached NOTICE OF REFERENCES CITED (PTO-892).
5. Note attached LIST OF REFERENCES CITED (PTO/SB/08 or PTO/SB/08 substitute).
6. The drawing correction request filed on _____ is: approved disapproved.
7. Acknowledgment is made of the priority claim under 35 U.S.C. § 119(a)-(d) or (f).
 - a) All b) Some* c) None of the certified copies have
 - been received.
 - not been received.
 - been filed in Application No. _____.
 - been filed in reexamination Control No. _____.
 - been received by the International Bureau in PCT Application No. _____.

* Certified copies not received: _____.
8. Note attached Examiner's Amendment.
9. Note attached Interview Summary (PTO-474).
10. Other: _____.

All correspondence relating to this reexamination proceeding should be directed to the **Central Reexamination Unit** at the mail, FAX, or hand-carry addresses given at the end of this Office action.

cc: Requester (if third party requester)

U.S. Patent and Trademark Office
PTOL-469 (Rev. 07-10)

Notice of Intent to Issue Ex Parte Reexamination Certificate

Part of Paper No 20130327

Notice of Intent to Issue Reexamination Certificate

This is a reexamination of United States Patent Number 5,796,183 ("the 183' patent"). In the reexamination request filed 08/17/2012 ("Request"), by Patent Owner, a substantial new question (SNQ) of patentability was raised as to claims 18 and 27. Those claims are thus reexamined herein. Reexamination was not requested of claims 1-17, 19-26 and 28-32. Therefore, claims 1-17, 19-26, and 27-31 will not be reexamined. See MPEP 2243. However, claims 28 and 32 will be reexamined, as further explained below.

A Patent Owner Statement was filed 11/19/2012, in which claims 18 and 27 were amended, as well as claims 28 and 32 due to their dependencies from claim 27. Furthermore, new claims 33-39 were added.

Within the examiner's discretion, the newly added claims 33-39 and the non-requested amended claims 28 and 32 are now subject to reexamination.

References

Boie et al., U.S. Patent No. 5,463,388, filed on January 29, 1993 and issued on October 31, 1996 ("Boie '388").

Statement of Reasons for Patentability and/or Confirmation

Claims 18, 27, amended non-requested claims 28, 32 and newly added claims 33-39 are patentable.

The examiner has no opinion as to the claims that were not reexamined. The following is an examiner's statement of reasons for patentability of the claims found patentable in this reexamination proceeding:

There is not taught or disclosed in the prior art *a capacitive responsive electronic switching circuit having a microcontroller using the periodic output signal from the oscillator, the microcontroller selectively providing signal output frequencies to a plurality of small sized input touch terminals of a keypad*, as called for in independent claim 18; nor *a capacitive responsive electronic switching circuit having a microcontroller using the periodic output signal from the oscillator, the microcontroller selectively providing signal output frequencies to a closely spaced array of input touch terminals of a keypad, the input touch terminals comprising first and second input touch terminals*, as called for in independent claims 27 and 37. The examiner agrees with the discussion articulated by Patent Owner in the Statement that Boie does not teach or suggest these claim elements. Rather, Boie discloses that "RF oscillator 408 provides an RF signal, for example, 100 kilohertz, to circuits 401, synchronous detector and filter 404 via inverter 410, and guard plane 411." Boie, col. 3:67-col. 4:2. Boie further discloses that "[t]he effects of electrode-to-electrode capacitances, wiring capacitances and other extraneous

Art Unit: 3992

capacitances are minimized by driving all electrodes and guard plane 411 in unison with the same RF signal from RF oscillator 408." *Id.* at col. 4:58-60 (emphasis added); *see id.* at Fig. 4. Thus Boie discloses driving the electrodes of electrode array 100 and guard plane 411 with a single RF signal. Boie does not teach or suggest providing signal output frequencies to these components. Accordingly, claims 18, 27, amended non-requested claims 28, 32, and newly added claims 33-39 are patentable.

Any comments considered necessary by PATENT OWNER regarding the above statement must be submitted promptly to avoid processing delays. Such submission by the patent owner should be labeled: "Comments on Statement of Reasons for Patentability and/or Confirmation" and will be placed in the reexamination file.

Correspondence

All correspondence relating to this *inter partes* reexamination proceeding should be directed:

By Mail to: Mail Stop *Inter Partes* Reexam
Attn: Central Reexamination Unit
Commissioner for Patents
United States Patent & Trademark Office
P.O. Box 1450
Alexandria, VA 22313-1450

By FAX to: (571) 273-9900
Central Reexamination Unit

By hand: Customer Service Window
Randolph Building
401 Dulany Street
Alexandria, VA 22314

Registered users of EFS-Web may alternatively submit such correspondence via the electronic filing system EFS-Web, at <https://efs.uspto.gov/efile/myportal/efs-registered> EFS-Web offers the benefit of quick submission to the particular area of the Office that needs to act on the correspondence. Also, EFS-Web submissions are "soft scanned" (i.e., electronically uploaded) directly into the official file for the reexamination proceeding, which offers parties the opportunity to review the content of their submissions after the "soft scanning" process is complete.

Any inquiry concerning this communication or earlier communications from the examiner, or as to the status of this proceeding, should be directed to the Central Reexamination Unit at telephone number (571) 272-7705.

/Linh M. Nguyen/
Primary Examiner, Art Unit 3992

Conferees:
/James Menefee/
Primary Examiner, Art Unit 3992

/Daniel Ryman/
Supervisory Patent Examiner, Art Unit 3992

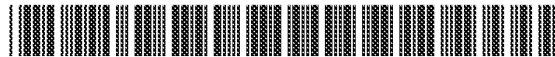

US005796183C1

(12) **EX PARTE REEXAMINATION CERTIFICATE** (9614th)
United States Patent
Hourmand et al.

(10) **Number:** US 5,796,183 C1
(45) **Certificate Issued:** Apr. 29, 2013

(54) **CAPACITIVE RESPONSIVE ELECTRONIC SWITCHING CIRCUIT**

(58) **Field of Classification Search**
None
See application file for complete search history.

(75) **Inventors:** **Byron Hourmand**, Hersey, MI (US);
John M. Washeleski, Cadillac, MI (US);
Stephen R. W. Cooper, Fowlerville, MI (US)

(56) **References Cited**

(73) **Assignee:** **Nartron Corporation**, Reed City, MI (US)

To view the complete listing of prior art documents cited during the proceeding for Reexamination Control Number 90/012,439, please refer to the USPTO's public Patent Application Information Retrieval (PAIR) system under the Display References tab.

Primary Examiner — Linh M. Nguyen

Reexamination Request:
No. 90/012,439, Aug. 17, 2012

(57) **ABSTRACT**

Reexamination Certificate for:
Patent No.: 5,796,183
Issued: Aug. 18, 1998
Appl. No.: 08/601,268
Filed: Jan. 31, 1996

A capacitive responsive electronic switching circuit comprises an oscillator providing a periodic output signal having a frequency of 50 kHz or greater, an input touch terminal defining an area for an operator provide an input by proximity and touch, and a detector circuit coupled to the oscillator for receiving the periodic output signal from the oscillator, and coupled to the input touch terminal. The detector circuit being responsive to signals from the oscillator and the presence of an operator's body capacitance to ground coupled to the touch terminal when in proximity or touched by an operator to provide a control output signal. Preferably, the oscillator provides a periodic output signal having a frequency of 800 kHz or greater. An array of touch terminals may be provided in close proximity due to the reduction in crosstalk that may result from contaminants by utilizing an oscillator outputting a signal having a frequency of 50 kHz or greater.

Certificate of Correction issued May 11, 1999

Certificate of Correction issued Oct. 11, 2011

(51) **Int. Cl.**
H03K 17/96 (2006.01)
H03K 17/94 (2006.01)
(52) **U.S. Cl.**
USPC 307/116; 307/125; 307/139; 361/181

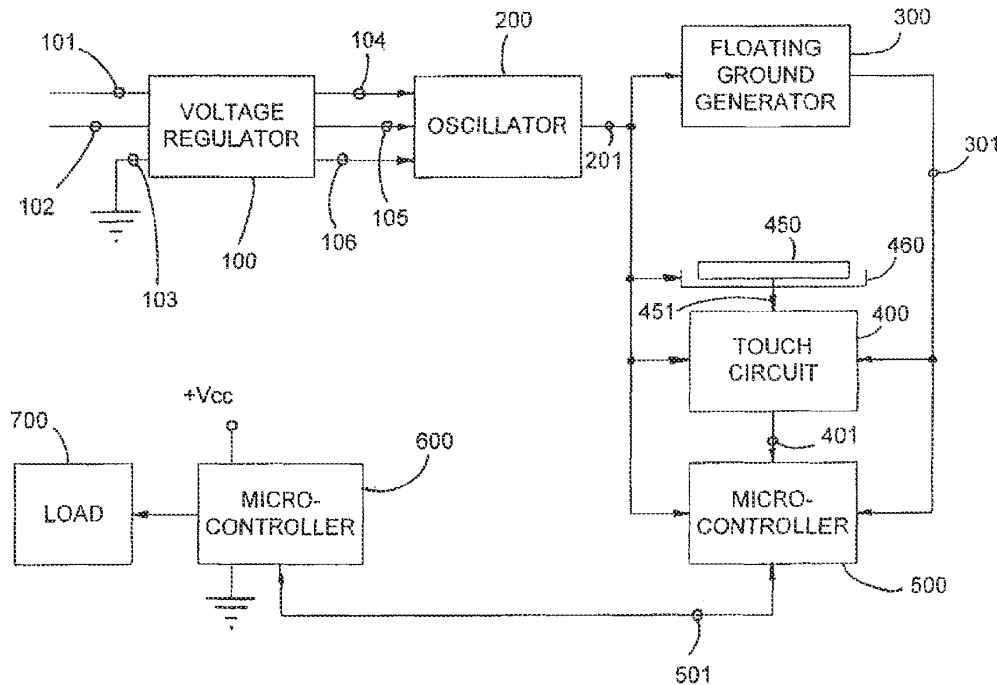

1
EX PARTE
REEXAMINATION CERTIFICATE
ISSUED UNDER 35 U.S.C. 307

THE PATENT IS HEREBY AMENDED AS
INDICATED BELOW.

Matter enclosed in heavy brackets [] appeared in the patent, but has been deleted and is no longer a part of the patent; matter printed in italics indicates additions made to the patent.

AS A RESULT OF REEXAMINATION, IT HAS BEEN DETERMINED THAT:

Claims 18, 27, 28 and 32 are determined to be patentable as amended.

New claims 33-39 are added and determined to be patentable.

Claims 1-17, 19-26 and 29-31 were not reexamined.

18. A capacitive responsive electronic switching circuit comprising:

an oscillator providing a periodic output signal having a predefined frequency;

a microcontroller using the periodic output signal from the oscillator, the microcontroller selectively providing signal output frequencies to a plurality of small sized input touch terminals of a keypad;

[a] *the plurality of small sized input touch terminals defining adjacent areas on a dielectric substrate for an operator to provide inputs by proximity and touch; and* a detector circuit coupled to said oscillator for receiving said periodic output signal from said oscillator, and coupled to said input touch terminals, said detector circuit being responsive to signals from said oscillator *via said microcontroller* and **[the]** a presence of an operator's body capacitance to ground coupled to said touch terminals when proximal or touched by **[an]** *the operator* to provide a control output signal,

wherein said predefined frequency of said oscillator **[is]** *and said signal output frequencies are selected to decrease [the] a first impedance of said dielectric substrate relative to [the] a second impedance of any contamine that may create an electrical path on said dielectric substrate between said adjacent areas defined by the plurality of small sized input touch terminals, and wherein said detector circuit compares [the] a sensed body capacitance change to ground proximate an input touch terminal to a threshold level to prevent inadvertent generation of the control output signal.*

27. A capacitive responsive electronic switching circuit for a controlled keypad device comprising:

an oscillator providing a periodic output signal having a predefined frequency;

a microcontroller using the periodic output signal from the oscillator, the microcontroller selectively providing signal output frequencies to a closely spaced array of input touch terminals of a keypad, the input touch terminals comprising first and second input touch terminals;

the first and second input touch terminals defining areas for an operator to provide an input by proximity and touch; and

a detector circuit coupled to said oscillator for receiving said periodic output signal from said oscillator, and coupled to said first and second touch terminals, said

2

detector circuit being responsive to signals from said oscillator *via said microcontroller* and **[the]** a presence of an operator's body capacitance to ground coupled to said first and second touch terminals when proximal or touched by **[an]** *the operator* to provide a control output signal for actuation of the controlled keypad device, said detector circuit being configured to generate said control output signal when **[an]** *the operator* is proximal or touches said second touch terminal after the operator is proximal or touches said first touch terminal.

28. The capacitive responsive electronic switching circuit as defined in claim 27, wherein said detector circuit generates said control signal only when **[an]** *the operator* is proximal or touches said second touch terminal within a predetermined time period after the operator is proximal or touches said first touch terminal.

32. The capacitive responsive electronic switching circuit as defined in claim 27 and further including an indicator for indicating when said detector circuit determines that **[an]** *the operator* is proximal or touches said first touch terminal.

33. *The capacitive responsive electronic switching circuit as defined in claim 18, further comprising wherein said detector circuit compares the sensed body capacitance change caused by the body capacitance decreasing an input touch terminal signal on the detector to ground when proximate to the input touch terminal to a second threshold level to generate the control output signal.*

34. *The capacitive responsive electronic switching circuit as defined in claim 18, further comprising wherein said detector circuit compares the sensed body capacitance change caused by the body capacitance decreasing an input touch terminal signal amplitude on the detector to ground when proximate to the input touch terminal to a second threshold level to generate the control output signal.*

35. *The capacitive responsive electronic switching circuit as defined in claim 27, wherein when the second touch terminal is not touched on its defining area by the operator to provide input, the control output signal is prevented.*

36. *The capacitive responsive electronic switching circuit as defined in claim 27 and further including an indicator for indicating when said detector circuit determines that the operator is proximal or touches said second touch terminal.*

37. *A capacitive responsive electronic switching circuit for a controlled device comprising:*

an oscillator providing a periodic output signal having a predefined frequency, wherein an oscillator voltage is greater than a supply voltage;

a microcontroller using the periodic output signal from the oscillator, the microcontroller selectively providing signal output frequencies to a closely spaced array of input touch terminals of a keypad, the input touch terminals comprising first and second input touch terminals;

the first and second touch terminals defining areas for an operator to provide an input by proximity and touch; and

a detector circuit coupled to said oscillator for receiving said periodic output signal from said oscillator, and coupled to said first and second touch terminals, said detector circuit being responsive to signals from said oscillator via said microcontroller and a presence of an operator's body capacitance to ground coupled to said first and second touch terminals when proximal or touched by the operator to provide a control output signal for actuation of the controlled device, said detector circuit being configured to generate said control output signal when the operator is proximal or touches said second touch terminal after the operator is proximal or touches said first touch terminal.

3

4

38. The capacitive responsive electronic switching circuit as defined in claim 37, wherein feedback to the operator is provided by an indicator activated by the microcontroller after the operator touches the second touch terminal.

39. The capacitive responsive electronic switching circuit 5 as defined in claim 37,

wherein said detector circuit compares a sensed body capacitance change caused by the body capacitance decreasing a second touch terminal signal on the detector to ground when proximate to the second touch terminal to a threshold level to generate the control output signal, and

wherein feedback to the operator is provided by an indicator activated by the microcontroller after the operator touches the second touch terminal. 15

* * * * *

EXHIBIT C



US005463388A

United States Patent [19]
Boie et al.

[11] Patent Number: 5,463,388
[45] Date of Patent: * Oct. 31, 1995

[54] COMPUTER MOUSE OR KEYBOARD INPUT DEVICE UTILIZING CAPACITIVE SENSORS

5,012,124	4/1991	Hollaway	341/33
5,016,098	5/1991	Gruaz et al.	341/33
5,113,041	5/1992	Blonder et al.	178/18
5,122,623	6/1992	Zank et al.	178/19

[75] Inventors: Robert A. Boie, Westfield; Laurence W. Ruedisueli, Berkeley Heights; Eric R. Wagner, South Plainfield, all of N.J.

OTHER PUBLICATIONS

"The Art of Electronics," Second Edition, Horowitz and Hill, p. 889, Cambridge University Press (1989).

[73] Assignee: AT&T IPM Corp., Coral Gables, Fla.

Primary Examiner—Brent Swarthout
Assistant Examiner—Thomas J. Mullen, Jr.
Attorney, Agent, or Firm—Geoffrey D. Green

[*] Notice: The portion of the term of this patent subsequent to May 12, 2009, has been disclaimed.

[57] ABSTRACT

A computer input device for use as a computer mouse or keyboard comprises a thin, insulating surface covering an array of electrodes. Such electrodes are arranged in a grid pattern and can be connected in columns and rows. Each column and row is connected to circuitry for measuring the capacitance seen by each column and row. The position of an object, such as a finger or handheld stylus, with respect to the array is determined from the centroid of such capacitance values, which is calculated in a microcontroller. For applications in which the input device is used as a mouse, the microcontroller forwards position change information to the computer. For applications in which the input device is used as a keyboard, the microcomputer identifies a key from the position of the touching object and forwards such key identity to the computer.

[21] Appl. No.: 11,040

[22] Filed: Jan. 29, 1993

[51] Int. Cl.⁶ H03K 17/94

[52] U.S. Cl. 341/33; 345/174

[58] Field of Search 341/33; 178/18, 178/19; 345/174

[56] References Cited

U.S. PATENT DOCUMENTS

4,733,222	3/1988	Evans	341/33
4,737,768	4/1988	Lewiner et al.	341/33
4,772,874	9/1988	Hasegawa	341/33
4,806,709	2/1989	Evans	178/19
4,852,443	8/1989	Duncan et al.	84/1,04
4,893,071	1/1990	Miller	324/660
4,972,496	11/1990	Sklarew	178/18 X

10 Claims, 6 Drawing Sheets

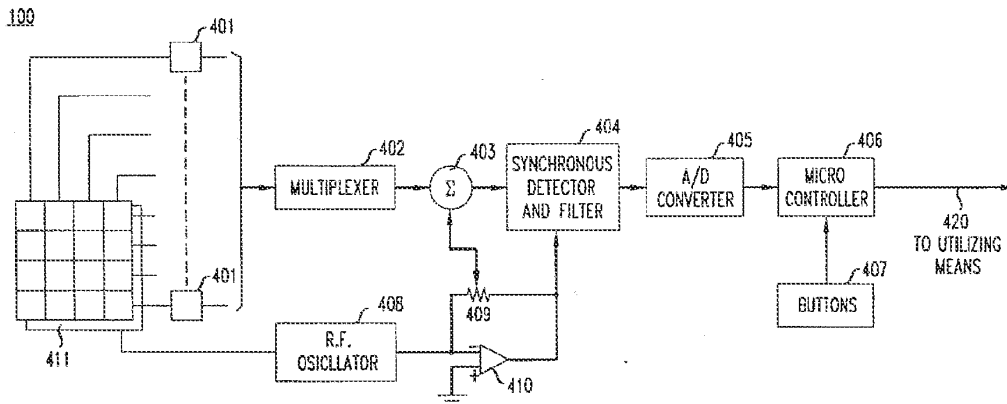

FIG. 1

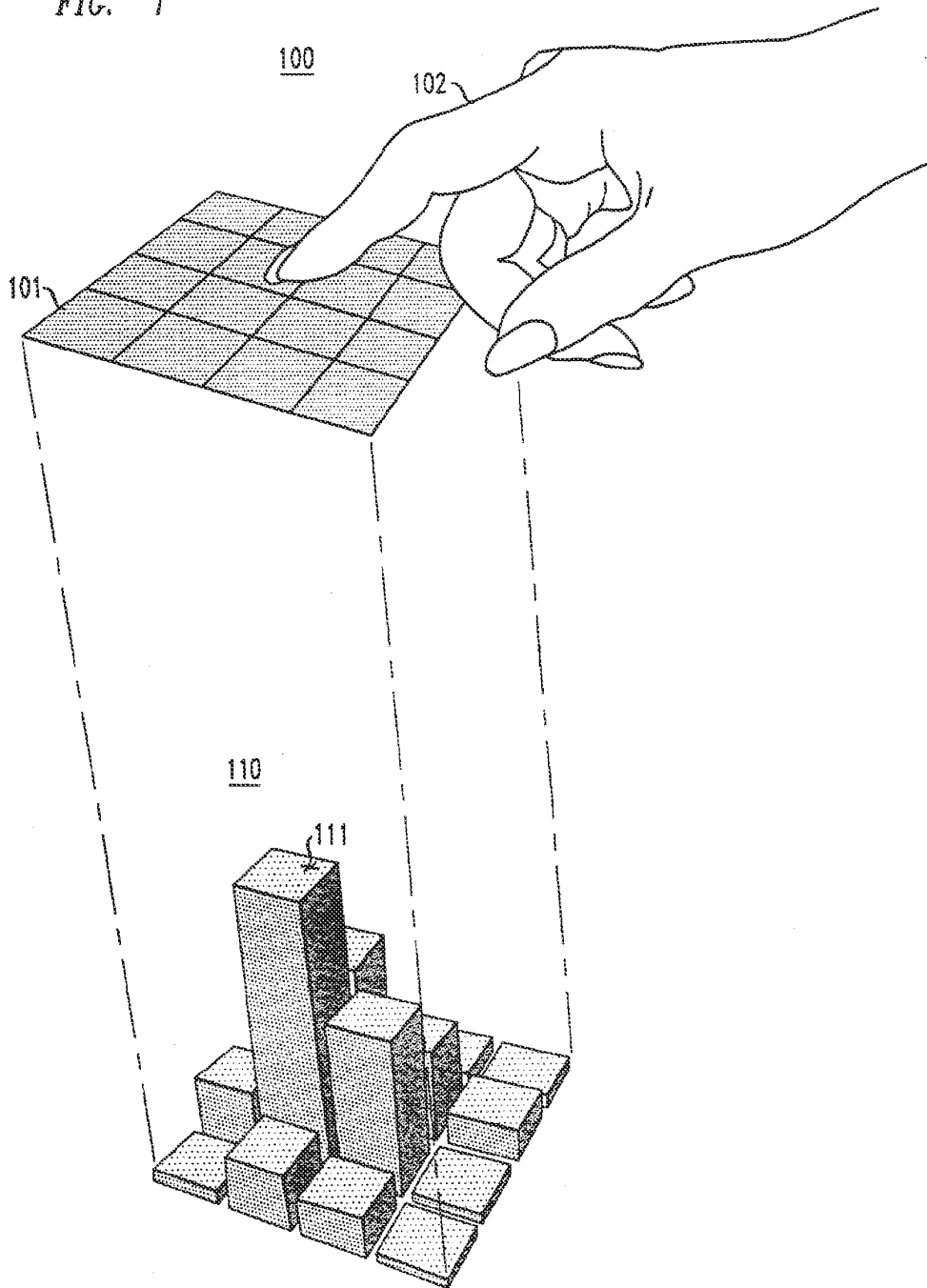

FIG. 2

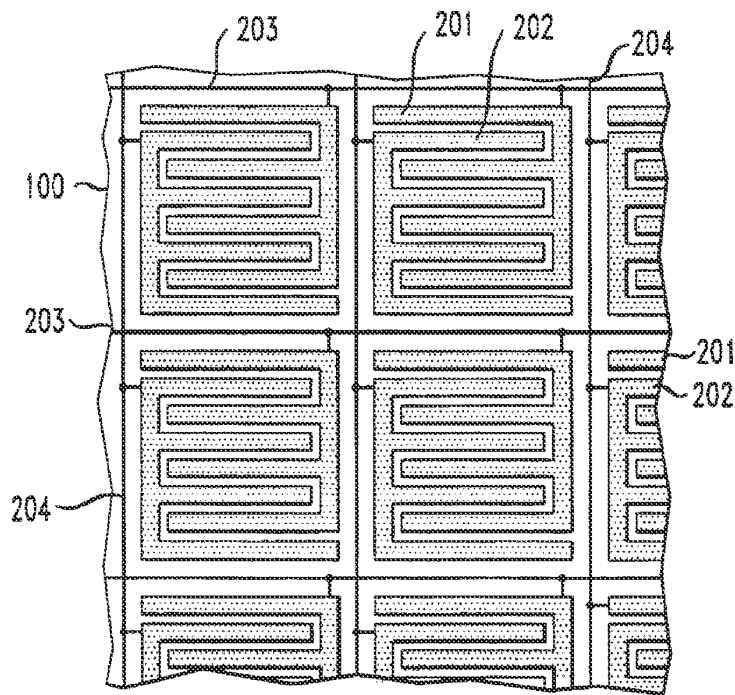

FIG. 3

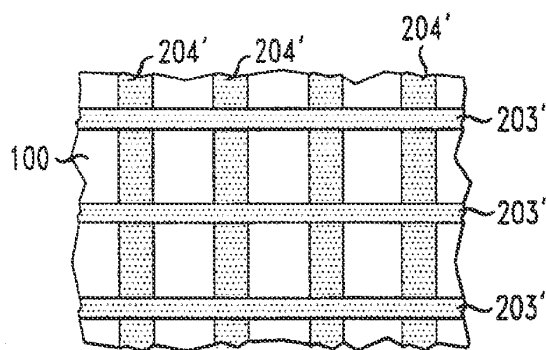

FIG. 4

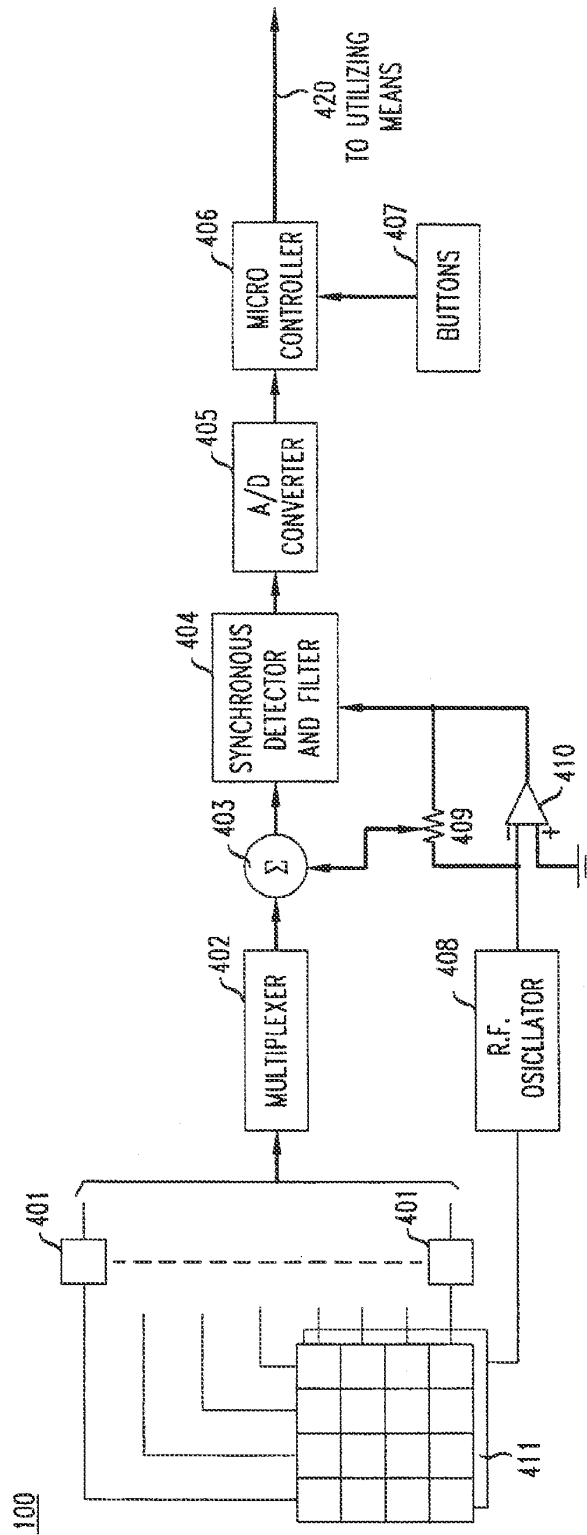

FIG. 5

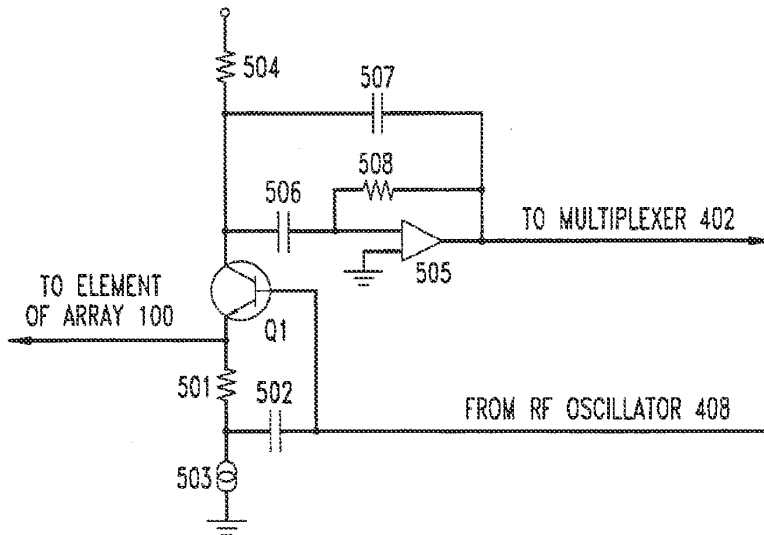

FIG. 7

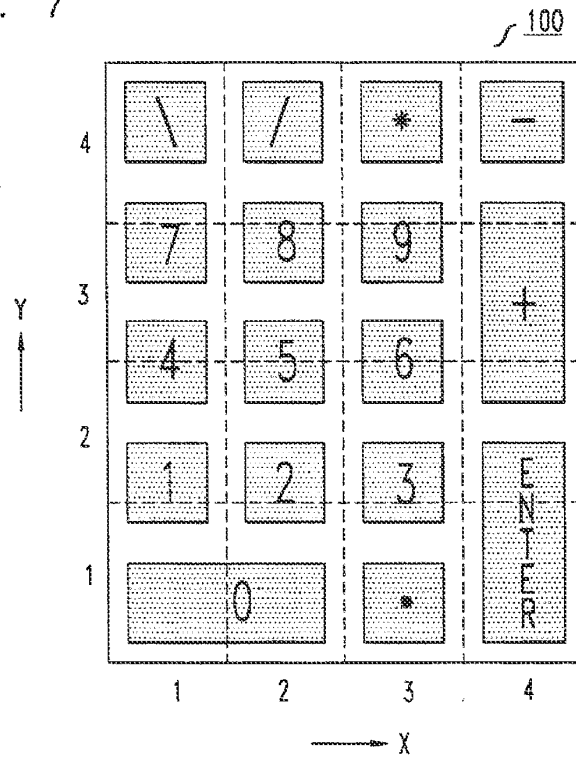

FIG. 6

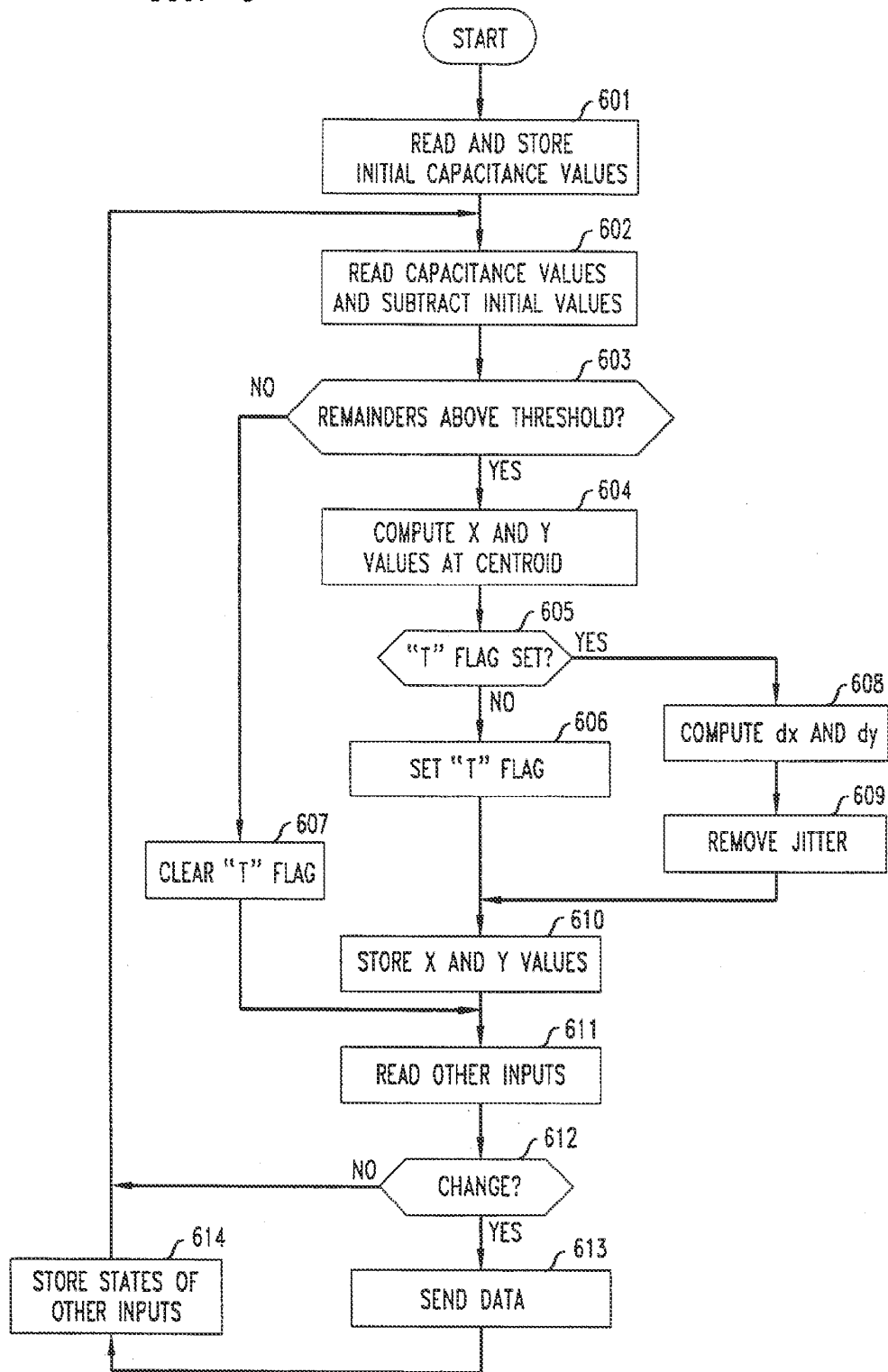
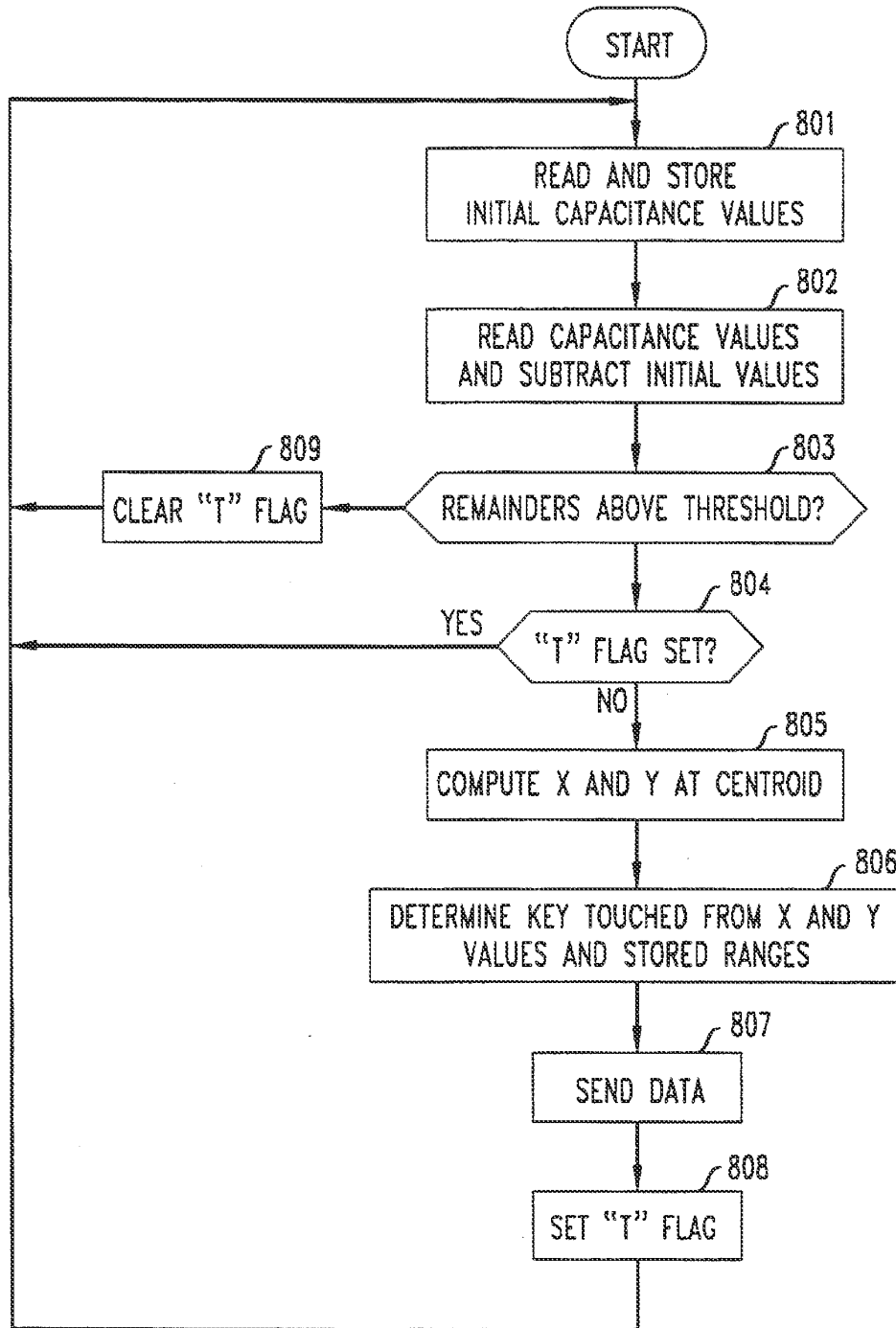

FIG. 8



1

COMPUTER MOUSE OR KEYBOARD INPUT DEVICE UTILIZING CAPACITIVE SENSORS

FIELD OF THE INVENTION

This invention relates to sensors for capacitively sensing the position or movement of an object, such as a finger, on a surface.

BACKGROUND OF THE INVENTION

Numerous devices are known for sensing the position of objects on surfaces, many of which relate to computer input tablets. For example, U.S. Pat. No. 5,113,041 to Greg E. Blonder et al. discloses a computer input tablet for use with a stylus in which the position of the stylus can be determined from signals transmitted to the stylus from a grid of signal lines embedded in the tablet, and U.S. Pat. No. 4,806,709 to Blair Evans discloses a touch-screen having a resistive layer with a number of point electrodes spaced thereon such that the position of a finger touching the screen can be determined from the relative values of the currents drawn from the point electrodes. The first such device requires means for the stylus itself to transmit information, such as a direct electrical connection. The second such device, and other kinds of tablets that sense the pressure of a finger or stylus, do not require such information-transmitting means.

Computer input tablets can be used for input of textual or graphical information. Various systems are known in the art which process handwritten text as if it were entered on a keyboard. Graphical information can also be captured by means of such tablets.

Other input devices such as computer "mice," joysticks and trackballs can be used with computers to control the position of a cursor on a display screen, such as a video terminal, for input of graphical information and for interactive programs such as computer games and programs using "windows" for display of information. Movement of a mouse in a particular direction on a surface causes a corresponding movement of the cursor or other object on the screen. Similarly, movement of a joystick or trackball in a particular direction causes such movement.

Input devices such as mice, joysticks and trackballs can be cumbersome because of their size and shape and, particularly with mice, the room needed for use. These drawbacks are more apparent with respect to portable computers, such as the so-called "notebook" computers. It is desirable, therefore, to furnish such control capabilities in an input device that can be incorporated in a small space, but without sacrificing ease of use. It is also desirable to be able to use such a device for multiple functions, for example, a particular area of a computer keyboard that can also be used as a mouse without losing its functionality as a keyboard. Further, it is desirable that such an input device be capable of operation by a finger or handheld stylus that does not require an electrical connection or other means for transmitting information.

SUMMARY OF THE INVENTION

The capacitive sensor of the invention comprises a thin, insulating surface covering a plurality of electrodes. The position of an object, such as a finger or hand-held stylus, with respect to the electrodes, is determined from the centroid of capacitance values measured at the electrodes. The electrodes can be arranged in one or two dimensions. In a two-dimensional array, the capacitance for each electrode

2

can be measured separately or the electrodes can be divided into separate elements connected in columns and rows and the capacitances measured for each column and row. The x and y coordinates of the centroid are calculated in a microcontroller from the measured capacitances. For applications in which the sensor is used to emulate a mouse or trackball, the microcontroller forwards position change information to utilizing means. For applications in which the sensor is used to emulate a keyboard, the microcontroller identifies a key from the position of the touching object and forwards such key identification to utilizing means.

These and other aspects of the invention will become apparent from the attached drawings and detailed description.

BRIEF DESCRIPTION OF THE DRAWING

FIG. 1 is a graphic diagram showing the relationship between the position of a user's finger and capacitances at electrodes in a two-dimensional sensor constructed in accordance with the invention.

FIG. 2 is a more detailed representation of interdigitated electrode components at the intersections of rows and columns in a two-dimensional sensor.

FIG. 3 is an alternate arrangement for electrodes in the array.

FIG. 4 is an overall block diagram of a two-dimensional capacitive position sensor in accordance with the invention.

FIG. 5 is a diagram of an integrating amplifier and bootstrap circuit associated with the electrodes.

FIG. 6 is a flow chart showing operation of the capacitive position sensor of the invention as a computer mouse or trackball.

FIG. 7 is a diagram showing use of the capacitive position sensor of the invention as a keyboard.

FIG. 8 is a flow chart showing operation of the capacitive position sensor of the invention as a keyboard.

DETAILED DESCRIPTION

The invention will be described in terms of an exemplary two-dimensional embodiment adapted to emulate a computer mouse or keyboard for use with a personal computer. However, it will be clear to those skilled in the art that the principles of the invention can be utilized in other applications in which it is convenient to sense position of an object capacitively in one or more dimensions.

The operational principle of the capacitive position sensor of the invention is shown in FIG. 1. Electrode array 100 is a square or rectangular array of electrodes 101 arranged in a grid pattern of rows and columns, as in an array of tiles. A 4x4 array is shown, which we have found adequate for emulating a computer mouse by finger strokes on the array. However, the invention can be used with arrays of other sizes, if desired. The electrodes are covered with a thin layer of insulating material (not shown). Finger 102 is shown positioned with respect to array 100. Electrode array 100 can be one-dimensional for applications in which position in only one dimension is to be sensed.

Histogram 110 shows the capacitances for electrodes 101 in array 100 with respect to finger 102. Such capacitances are a two-dimensional sampling of the distribution of capacitance between array 100 and finger 102. The centroid (center of gravity or first moment) 111 of such distribution will correspond to the position of finger 102, or some other object touching array 100, if suitable sampling criteria are

met; that is, by choosing electrodes of sufficiently small size when compared to the extent of the distribution. Such criteria are discussed in the Blonder et al. patent referred to above.

The x and y coordinates of the centroid can be determined by directly measuring the capacitance at each electrode 101 and calculating such x and y coordinates from such measured capacitances. Thus, for the 4x4 array 100, sixteen capacitance measurements would be needed. The number of measurements can be reduced, however, by taking advantage of the fact that the one-dimensional centroids of the projections of the distribution onto the x and y axes also correspond to the finger position. Such projections can be formed by subdividing each electrode 101 into two elements, as shown in FIG. 2.

FIG. 2 shows four such subdivided electrodes in more detail at an intersection of two rows and two columns in array 100. As can be seen from FIG. 2, a horizontal element 201 and a vertical element 202 are situated at each intersection of a row and column. Horizontal elements 201 are interconnected by leads 203 and vertical elements 202 are interconnected by leads 204. Elements 201 and 202 can be interdigitated as shown. It is advantageous for the conducting areas of elements 201 and 202 to cover the surface of array 100 as completely as possible. For finger strokes, we have used interdigitated elements 201 and 202 that are approximately 0.37" square. Smaller electrodes 101 or elements 201 and 202 be desirable for use with a hand-held stylus having a smaller cross-section than a finger.

As will be clear to those skilled in the art, elements 201 and 202 can be fabricated in one plane of a multi-layer printed circuit board together with one set of interconnections, for example, the horizontal row connections 203. The vertical row connections 204 can then be fabricated in another plane of the circuit board with appropriate via connections between the planes.

Other electrode array configurations can be used, if desired. For example, FIG. 3 shows horizontal strip electrodes 203' overlapping vertical strip electrodes 204'. Electrodes 203' and 204' are separated by a thin insulating layer (not shown) and covered by another thin insulating layer (not shown). In such a configuration, areas of electrodes 204' must be left unmasked by electrodes 203' so that electrodes 204' can still "see" the capacitance of an object touching the surface in which such electrodes are embedded. A similar configuration of electrodes is shown in the Blonder et al. patent. However, the structure of FIG. 2 is preferred because the interdigitated elements 201 and 202 do not overlap and the capacitance values measured can be higher for a given area of array 100, thus providing greater noise immunity.

FIG. 4 is an overall block diagram of a capacitive sensor 400 in accordance with the invention. Electrode array 100 comprises rows and columns of electrodes, for example, rows and columns of connected horizontal and vertical elements as shown in FIG. 2. Referring again to FIG. 4, each row and column of electrodes from array 100 is connected to an integrating amplifier and bootstrap circuit 401, which is shown in more detail in FIG. 5 and will be described below. Each of the outputs from circuits 401 can be selected by multiplexer 402 under control of microcontroller 406. The selected output is then forwarded to summing circuit 403, where such output is combined with a signal from trimmer resistor 409. Synchronous detector and filter 404 convert the output from summing circuit 403 to a signal related to the capacitance of the row or column selected by multiplexer 402. RF oscillator 408 provides an RF signal,

for example, 100 kilohertz, to circuits 401, synchronous detector and filter 404 via inverter 410, and guard plane 411. Guard plane 411 is a substantially continuous plane parallel to array 100 and associated connections, and serves to isolate array 100 from extraneous signals. The operation of synchronous detector and filter 404 is well known in the art, for example, see page 889 of "The Art of Electronics," Second Edition, by Horowitz and Hill, Cambridge University Press (1989). A capacitive proximity detector having a single electrode, a guard plane and similar circuitry is disclosed in co-pending Application No. 07/861,667 for R. A. Boic et al. filed Apr. 1, 1992, now U.S. Pat. No. 5,337,353.

Apparatus similar to that shown in FIG. 4 can also be used for applications in which it is desired to measure separate capacitance values for each electrode in array 100 instead of the collective capacitances of subdivided electrode elements connected in rows and columns. To measure such capacitances separately, a circuit 401 is provided for each electrode in array 100 and multiplexer 402 is enlarged to accommodate the outputs from all circuits 401.

The output of synchronous detector and filter 404 is converted to digital form by analog-to-digital converter 405 and forwarded to microcontroller 406. Thus, microcontroller 406 can obtain a digital value representing the capacitance seen by any row or column of electrode elements (or electrode if measured separately) selected by multiplexer 402. Buttons 407, which can be auxiliary pushbuttons or switches situated near array 400, are also connected to microcontroller 406. Buttons 407 can be used, for example, for the same purposes as the buttons on a computer mouse. Microcontroller 406 sends data to utilizing means, such as a personal computer (not shown) over lead 420. A particular device that can be used for A/D converter 405 and microcontroller 406 is the 87C552 circuit made by Intel Corporation, which includes both an A/D converter and a microprocessor.

FIG. 5 is a circuit diagram of each integrating amplifier and bootstrap circuit 401. The RF signal from RF oscillator 408 drives the base of transistor Q1 and the bootstrap circuit comprised of resistor 501 and capacitor 502. Current source 503 provides a constant DC bias current through transistor Q1. An electrode in array 100 is connected to the emitter of transistor Q1. The RF current to an electrode is determined by the capacitance seen by the electrode; thus, an increase in capacitance caused by the proximity of an object, such as a finger, causes an increase in such current. Such an increase is reflected as a change in the RF current flowing from the collector of transistor Q1. The collector of transistor Q1 is connected to the input node of integrating amplifier 505 via coupling capacitor 506. For a change in capacitance, ΔC , at the electrode, the change in the amplitude of the output signal from amplifier 505 will be approximately $A(\Delta C/C_p)$, where A is the amplitude of the RF signal from oscillator 408 and C_p is the value of integrating capacitor 507. Resistor 508 provides a bias current for amplifier 505 and resistor 504 provides bias current for transistor Q1.

The effects of electrode-to-electrode capacitances, wiring capacitances and other extraneous capacitances are minimized by driving all electrodes and guard plane 411 in unison with the same RF signal from RF oscillator 408. The bootstrap circuit serves to minimize any signal due to the finite impedance of the biasing circuit of transistor Q1. The base-to-collector capacitance of transistors Q1 and other stray capacitances in the circuit can be compensated for by adjusting trim resistor 109 shown in FIG. 1.

In using the position sensor of the invention as a computer

mouse or trackball to control a cursor, movement of the mouse or trackball is emulated by touching array 100 with finger 102, or some other object, and stroking finger 102 over array 100 to move the cursor. Changes in position of the finger with respect to array 100 are reflected in corresponding changes in position of the cursor. Thus, for such an application, microcontroller 406 sends data over lead 420 relating to changes in position. FIG. 6 is a flow chart of the operation of microcontroller 406 in such an application.

Referring to FIG. 6, microcomputer 406 reads the initial capacitance values for all the elements in array 100 and stores such values (step 601). Such initial values should reflect the state of array 100 without a finger or other object being nearby, accordingly, it may be desirable to repeat step 601 a number of times and then to select the minimum capacitance values read as the initial values, thereby compensating for the effect of any objects moving close to array 100 during the initialization step. After initialization, all capacitance values are periodically read and the initial values subtracted to yield a remainder value for each element (step 602). If one or more of the remainders exceeds a preset threshold (step 603), indicating that an object is close to or touching array 100, then the x and y coordinates of the centroid of capacitance for such object can be calculated from such remainders (step 604). For applications in which the electrodes of array 100 are connected in rows and columns, as shown in FIG. 2 and FIG. 3, such calculation can be performed as follows:

$$x = \frac{u_x \sum_{n_x=1}^{n_x} n_x V(n_x)}{u_y \sum_{n_x=1}^{n_x} V(n_x)}$$

$$y = \frac{u_y \sum_{n_y=1}^{n_y} n_y V(n_y)}{u_x \sum_{n_y=1}^{n_y} V(n_y)}$$

where:

u_x is the number of columns, $V(n_x)$ is the remainder value for column n_x , u_y is the number of rows and $V(n_y)$ is the remainder value for row n_y . To avoid spurious operation, it may be desirable to require that two or more measurements exceed the preset threshold. The threshold can be set to some percentage of the range of A/D converter 405, for example 10-15% of such range. Note that the value of x can neither be less than 1 nor more than u_x , and the value of y can neither be less than 1 nor more than u_y .

For applications in which the capacitance values for the electrode 101 in array 100 are measured separately, the x and y values of the centroid can also be calculated using equations (1) and (2) by adding all the capacitances measured for a row or column to obtain the value of V for such row or column. Such addition has the same effect as if the electrodes were connected together in a row or column.

When set, the "T" flag indicates that remainders were above the threshold during the previous iteration through step 603. Such flag is set during step 606 and cleared during step 607. Thus, after the first iteration through step 603, indicating a new stroke of finger 102 on array 100, the "T" flag is set and the x and y values just calculated are stored. During each subsequent iteration during such stroke, the changes in x and y (dx and dy) are calculated (step 608) as follows:

$$dx = x_c - x_p \quad (3)$$

$$dy = y_c - y_p \quad (4)$$

where x_c and y_c are the values just calculated in step 605 and x_p and y_p are the values calculated and stored (step 610) during the previous iteration.

It may be desirable to remove jitter from the least-significant bit in the values of dx and dy calculated (step 609). This can be accomplished by incrementing negative values by 1 and decrementing positive values by 1, leaving zero values without change.

The values calculated for x and y are stored (step 610) for use in calculating dx and dy during the next iteration. Then, if other inputs, such as buttons 407, are connected to microcontroller 406, the state of such inputs is read (step 611). Finally, if x and y have changed ($dx \neq 0$ or $dy \neq 0$) or the state of buttons 407 has changed (step 612), data relating to such changes is sent over line 420 to the computer or other utilizing means to which sensor 400 is connected (step 613). Such data typically includes dx, dy and the current state of the buttons, which corresponds to that sent to a computer by a conventional computer mouse or trackball. Finally the states of such other inputs are stored (step 614) for use during the next iteration.

Typically the cycle time through the above-described steps will be about 20 milliseconds, depending on the time constant of the filter in circuit 404. After each change of multiplexer 402, microcontroller 406 is programmed to wait approximately 2 milliseconds for the output of circuit 404 to settle.

It will be clear that the absolute values of x and y can be included in the data sent over line 420 to utilizing means, if desired. For example, capacitive input sensor 400 can be adapted for use as a general purpose input pad for entering handwritten information. For such an application, it may be desirable to increase the number of electrodes to improve definition, but even a 4x4 matrix for use with finger input can produce useful input data because of the interpolating effect of the centroid-finding calculations performed in step 604.

Instead of using buttons 407 for additional input when array sensor 100 is used as a computer mouse, it may be desirable to sense different finger pressures. For example, to perform a "click and drag" operation, a typical use of a computer mouse, a heavier finger pressure can be used on array 100 than when an ordinary cursor movement is desired. Clearly finger pressures can be sensed by electro-mechanical or other means, but differences in the capacitances sensed by sensor 400 can also be used for this purpose.

The magnitudes of the capacitance values sensed by array 100 are somewhat related to finger pressure because of the compressibility of the fingertip when contacting array 100. Higher finger pressure will cause higher capacitance values to be sensed. This effect can be enhanced by replacing the insulating layer (not shown) on array 100 with a compressible insulating layer. Different finger pressures can be set by defining one or more additional thresholds for use in step 603. An ordinary touch would cause the remainders to exceed only the first threshold; a heavier touch would cause at least one remainder to exceed a higher threshold, which could then be used to indicate a different button state.

FIG. 7 is a diagram showing how an array 100 can be used as a keyboard in accordance with the invention. Again, array 100 is shown as a 4x4 matrix of electrodes, but with a keyboard pattern overlay superimposed on the matrix. The dotted lines indicate such matrix. Such a keyboard pattern can be printed on the insulating layer covering the electrodes. Note that the individual "keys" in the keyboard do

not necessarily correspond to the underlying electrodes. The x and y coordinates are shown for reference purposes. Since the values obtained for x and y in a 4x4 matrix using equations (1) and (2) will range from 1 to 4, this range is shown on the coordinates.

The identity of a key touched is determined from the x and y values computed for the centroid of capacitance resulting from the touch. For example, using the x and y coordinates shown in FIG. 7, a "5" can be defined as a touch with $[1.7 \leq x \leq 2.3, 2.3 \leq y \leq 2.7]$; a "0" can be defined as a touch with $[1 \leq x \leq 2.3, 1 \leq y \leq 1.3]$; and a "+" can be defined as a touch with $[3.7 \leq x \leq 4, 2.4 \leq y \leq 3.5]$. These ranges are chosen to leave guard bands between adjacent keys. Such a range for each key on the keyboard is stored in microprocessor 406.

FIG. 8 is a flow chart showing operation of microcontroller 406 when the capacitive position sensor of the invention is used as a keyboard. Steps 801, 802, 803 and 805 are similar to steps 601, 602, 603 and 604, respectively, in FIG. 6. In step 805, the identity of the key touched is determined from the stored ranges and the values of x and y calculated in step 806. In step 807, the identity of the key touched is sent to utilizing means. The "T" flag is set in step 808, cleared in step 809 and tested in step 804. Such flag assures that the key identity is sent to utilizing means only once.

It should be clear that the various ways described above of using the capacitive position sensor of the invention can be combined. For example, a combination mouse-keyboard can be implemented in which one portion of array 100 is used as a mouse responsive to finger strokes and a second portion is used as a keyboard responsive to finger touches. Alternatively, array 100 can be adapted to operate in different modes: the first mode as a mouse, the second as a keyboard. Switching between modes can be accomplished, for example, with one of buttons 407, or with extra pressure in a specified region of array 100. Thus, where space is at a premium, such as in a portable computer, the capacitive position sensor of the invention can be used as part of the keyboard and also as a mouse.

The invention has been shown and described with reference to particular embodiments. However, it will be understood by those skilled in the art that various changes may be made therein without departing from the spirit and scope of the invention.

What is claimed is:

1. A sensor for capacitively sensing the position in a continuous range of positions of an object on a surface of an input device, which comprises:

an array of electrodes on said surface;

an insulating layer covering said electrodes;

means connected to said electrodes for measuring a capacitance value for each said electrode;

means responsive to said measuring means for comparing said capacitance values with a first preset threshold and, if at least one of said capacitance values exceeds said first preset threshold, for calculating the position of a centroid of capacitance for said array from said measured capacitance values, said first preset threshold being set at a capacitance value that is exceeded for a given electrode only when said object is close to or touching said given electrode, said centroid of capacitance being the first moment of the distribution of said capacitance values in said array and representing substantially the position of said object on said surface; and

means responsive to said calculating means and con-

nected to utilizing means for sending said centroid of capacitance position to said utilizing means.

2. The sensor of claim 1 in which said array is a two-dimensional array and said electrodes are arranged in rows and columns.

3. The sensor of claim 2 wherein said input device is a keyboard, said sensor further comprising:

means for designating portions of the surface of said keyboard to represent different keys; and

said calculating means comprises:

means for storing a range of coordinates for each key in said keyboard;

means for comparing said centroid of capacitance position with said ranges of coordinates and selecting the range of coordinates in which said centroid of capacitance position falls; and

said sending means comprises means for sending the identity of the key associated with said selected range of coordinates to said utilizing means.

4. The sensor of claim 2 wherein each said electrode comprises:

at each intersection of a row and a column, a first electrode element connected to other first electrode elements in said row and a second electrode element connected to other second electrode elements in said column,

and wherein said means for measuring a capacitance value for each electrode is adapted to measure the capacitance value for each row of said first electrode elements and the capacitance value for each column of said second electrode elements.

5. The sensor of claim 4 wherein said first and second electrode elements at each intersection are interdigitated.

6. The sensor of claim 1 wherein said calculating means periodically calculates changes in said centroid of capacitance position and said sending means periodically sends said changes to said utilizing means.

7. The sensor of claim 1 which further comprises:

means responsive to said measuring means for comparing said capacitance values with a second preset threshold and for indicating to said utilizing means when said second preset threshold is exceeded, said second preset threshold being set at a capacitance value higher than said first preset threshold.

8. The sensor of claim 1 wherein said measuring means comprises:

means connected to said electrodes for supplying the same RF signal in unison to each said electrode,

means connected to said electrodes for sensing RF currents flowing between said electrodes and said object in response to said RF signal, and

means connected to said RF current sensing means for converting said RF currents into signals representative of said capacitance values for each said electrode.

9. The sensor of claim 8, which further comprises:

a guard plane substantially parallel to said electrodes, and said means for supplying an RF signal further comprises:

means connected to said guard plane for supplying said RF signal to said guard plane in unison with the RF signals supplied to said electrodes.

10. A touch-sensitive input device for a computer, which comprises:

an array of electrodes on a surface of said input device, said electrodes being arranged in rows and columns;

9

an insulating layer covering said electrodes;
 means connected to said electrodes for measuring a
 capacitance value for each said electrode;
 means responsive to said measuring means for comparing
 said capacitance values with a first preset threshold
 and, if at least one of said capacitance values exceeds
 said first preset threshold, for calculating the coordi-
 nates of a centroid of capacitance for said array from
 said measured capacitance values, said centroid of
 capacitance corresponding to the position of a finger or
 other object touching said surface, said first preset
 threshold being set at a capacitance value that is
 exceeded for a given electrode only when said finger or

10

other object is close to or touching said surface in the
 vicinity of said given electrode, said centroid of capaci-
 tance being the first moment of the distribution of said
 capacitance values in said array and representing sub-
 stantially the position of said object in a continuous
 range of positions on said surface; and
 means responsive to said calculating means and con-
 nected to said computer for sending information to said
 computer indicative of or derived from said calculated
 coordinates.

* * * * *

EXHIBIT D

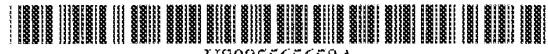

US005565658A

United States Patent [19]
Gerpheide et al.

[11] **Patent Number:** **5,565,658**
[45] **Date of Patent:** **Oct. 15, 1996**

[54] **CAPACITANCE-BASED PROXIMITY WITH INTERFERENCE REJECTION APPARATUS AND METHODS**

4,371,746	2/1983	Pepper, Jr.	178/18
4,476,463	10/1984	Ng et al.	178/187
4,845,682	7/1989	Boozer et al.	342/16 X
5,053,757	10/1991	Meadows	178/18 X
5,305,017	4/1994	Gerpheide	345/174

[75] Inventors: **George E. Gerpheide; Michael D. Layton**, both of Salt Lake City, Utah

[73] Assignee: **Cirque Corporation**, Salt Lake City, Utah

Primary Examiner—Stephen Chin
Assistant Examiner—Paul Loomis
Attorney, Agent, or Firm—Thorpe, North & Western

[21] Appl. No.: **351,008**

[22] Filed: **Dec. 7, 1994**

[57] **ABSTRACT**

Apparatus and method for a capacitance-based proximity sensor with interference rejection. A pair of electrode arrays establish a capacitance on a touch detection pad, the capacitance varying with movement of a conductive object near the pad. The capacitance variations are measured synchronously with a reference frequency signal to thus provide a measure of the position of the object. Electrical interference is rejected by producing a reference frequency signal which is not coherent with the interference.

Related U.S. Application Data

[63] Continuation-in-part of Ser. No. 193,275, Feb. 8, 1994, Pat. No. 5,478,170, which is a continuation of Ser. No. 914,043, Jul. 13, 1992, Pat. No. 5,305,017.

[51] **Int. Cl.⁶** **G08C 21/00**

[52] **U.S. Cl.** **178/19; 345/174**

[58] **Field of Search** 178/18, 19, 20; 345/168, 173, 174; 328/5; 342/16

[56] **References Cited**

U.S. PATENT DOCUMENTS

4,237,421 12/1980 Waldron 325/5

14 Claims, 8 Drawing Sheets

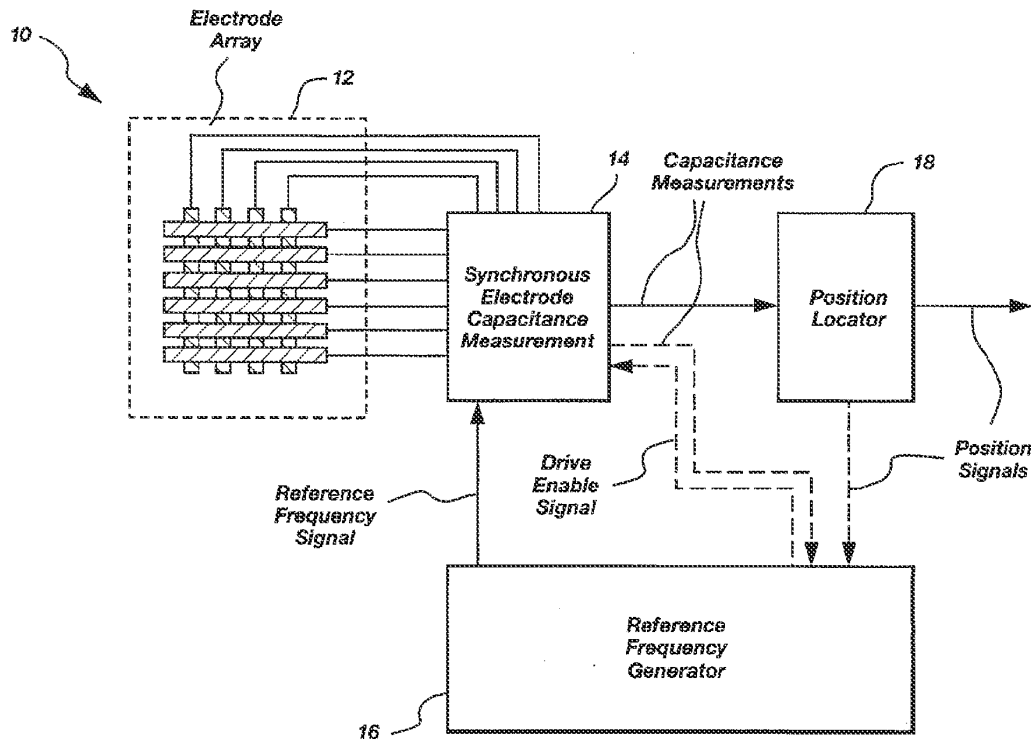

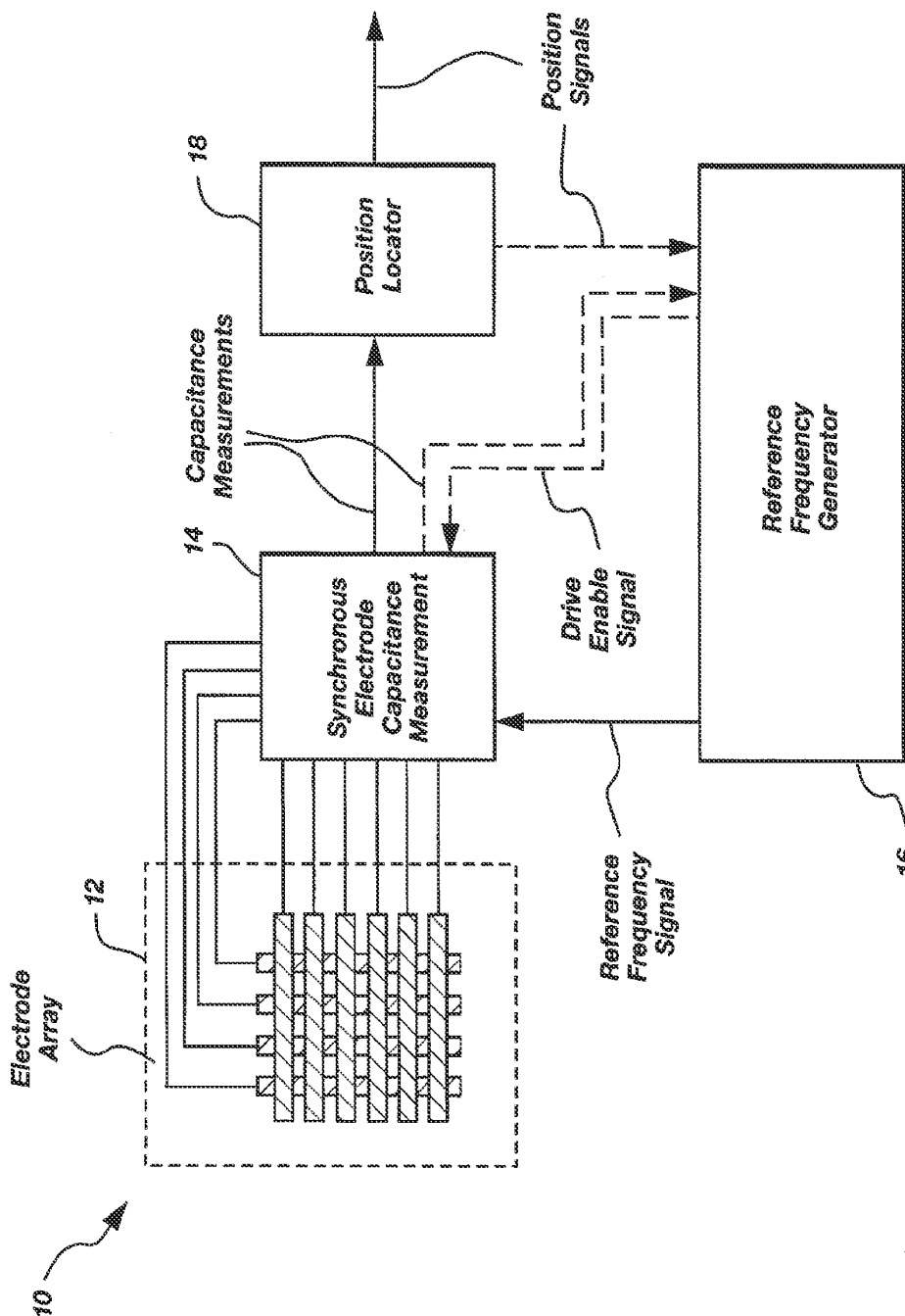

Fig. 1

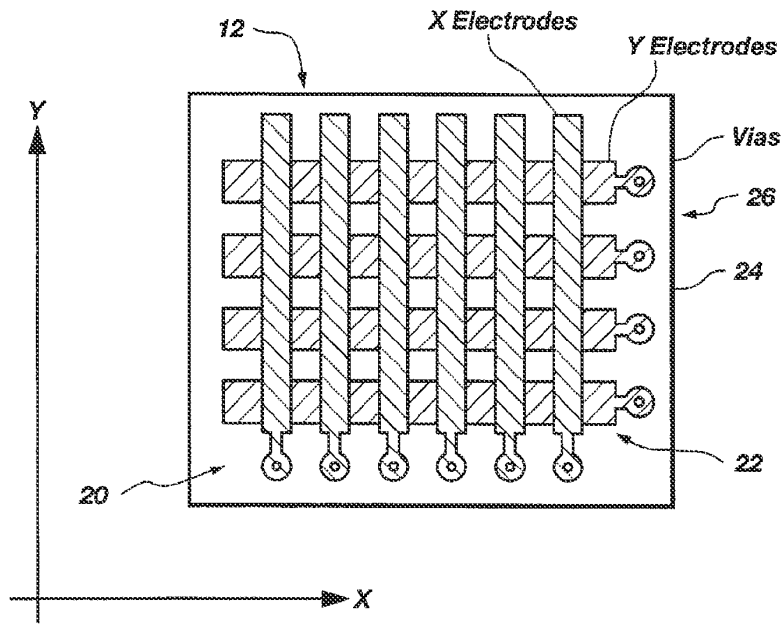

Fig. 2a

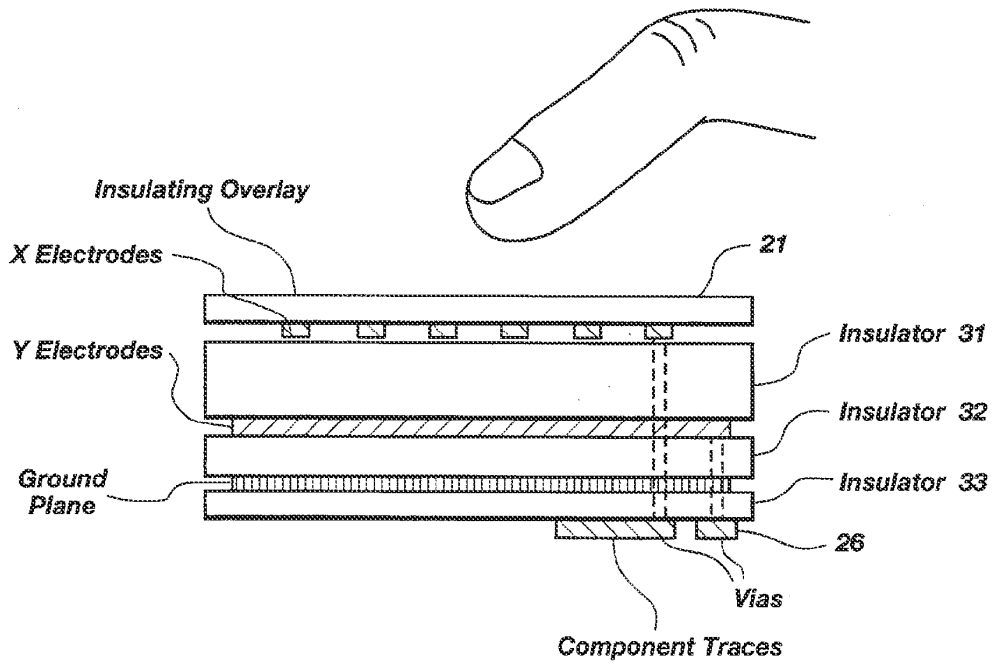

Fig. 2b

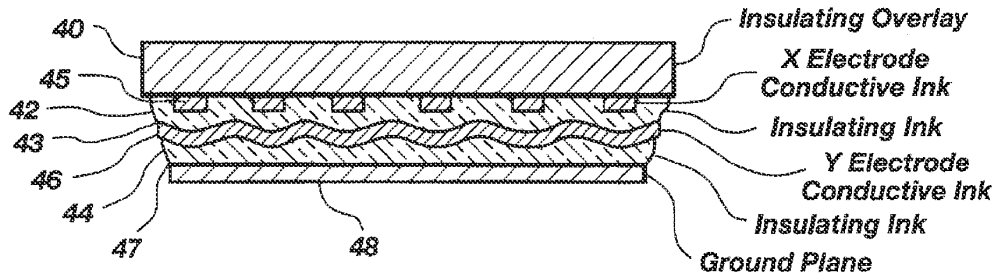

Fig. 3a

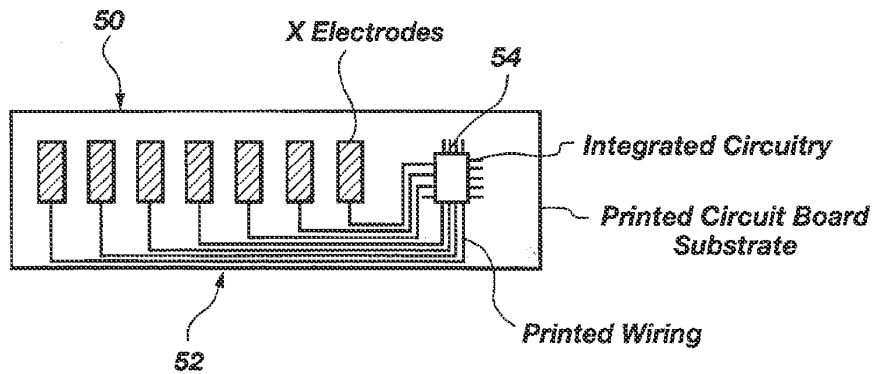

Fig. 3b

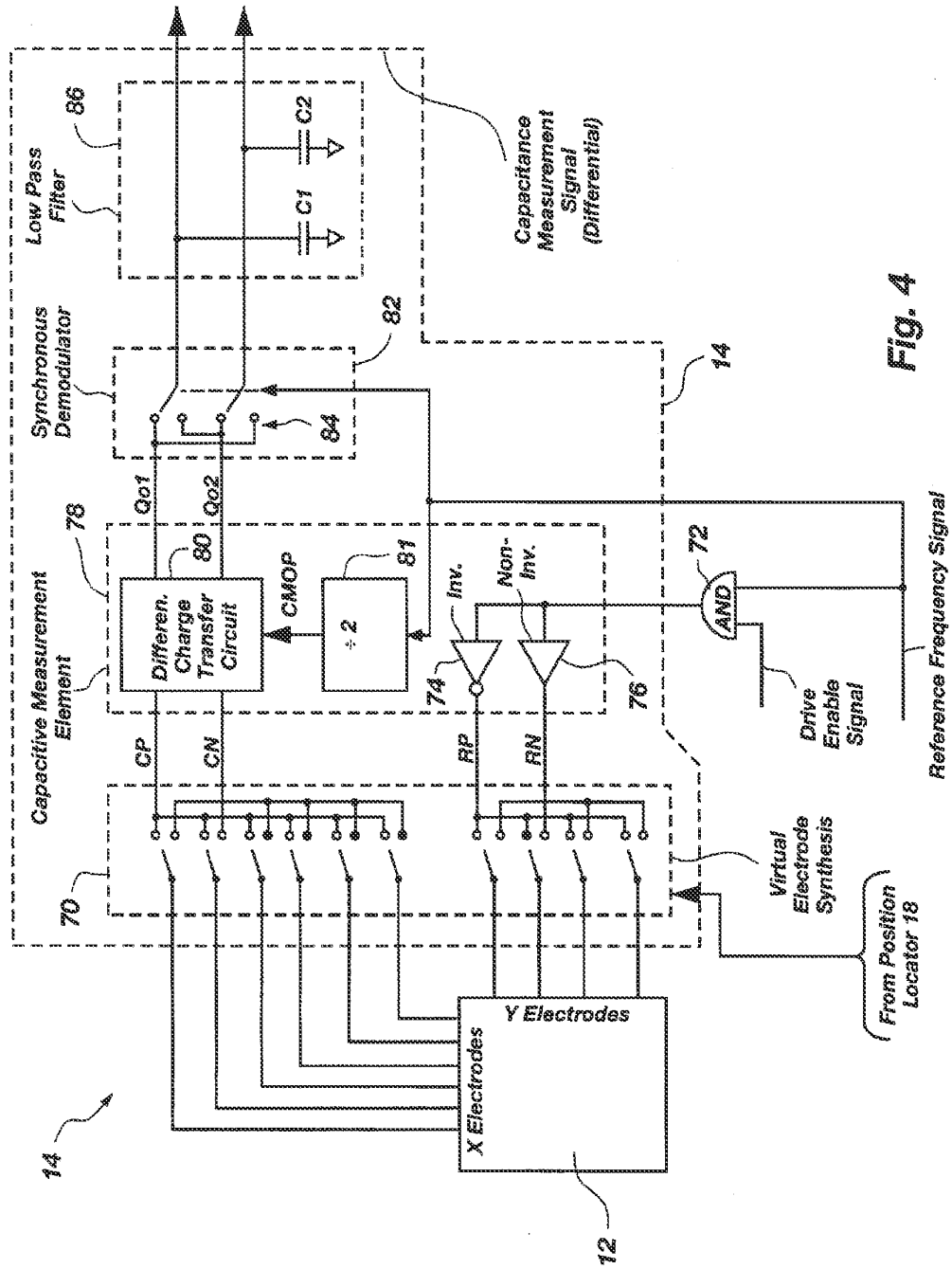

Fig. 4

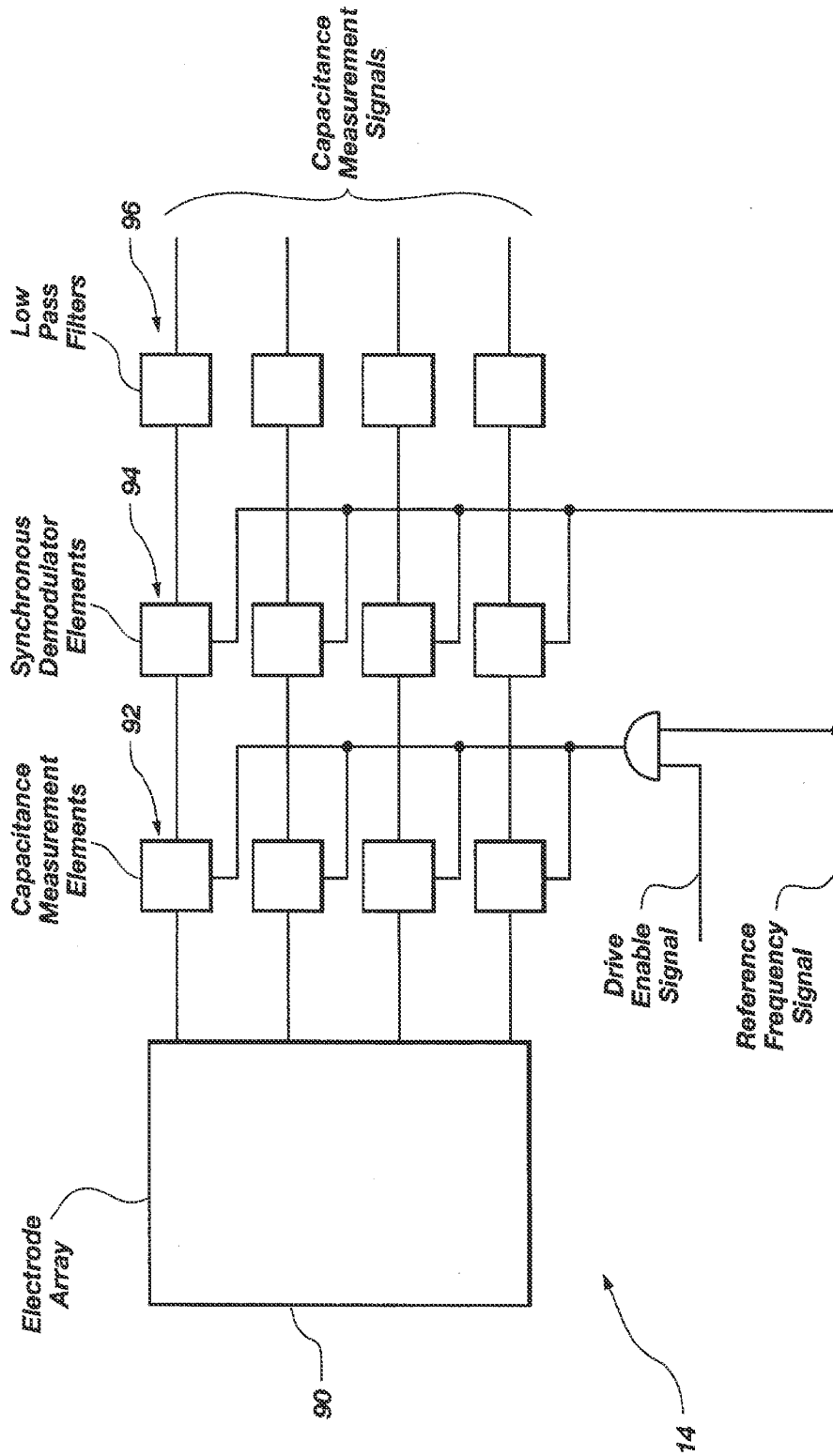
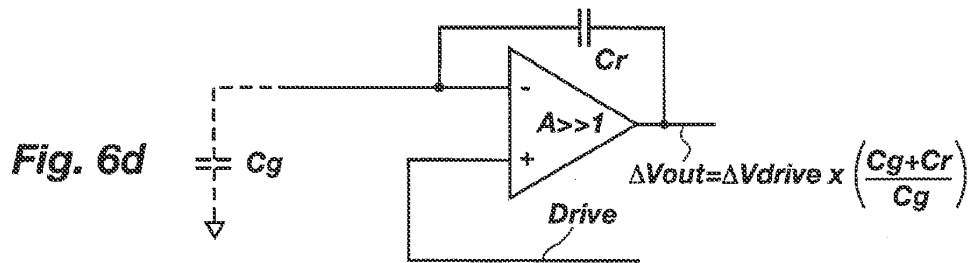
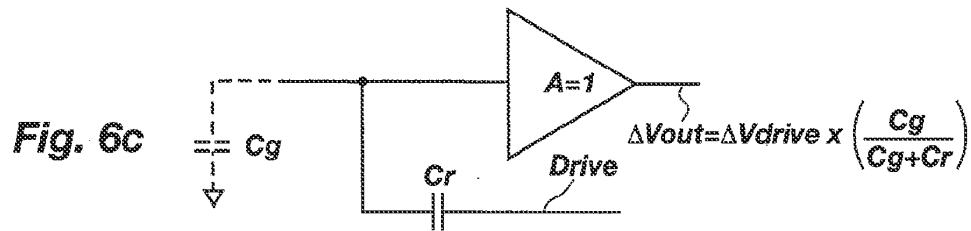
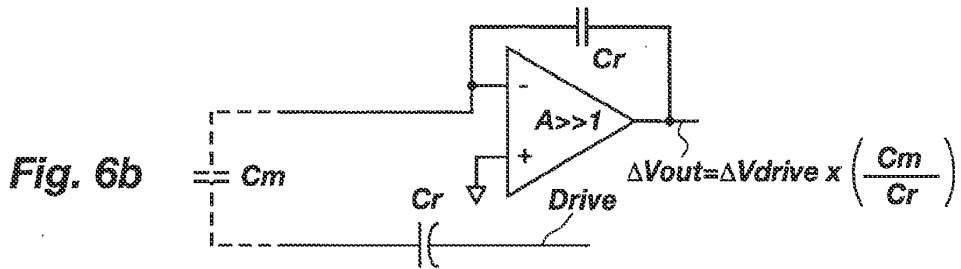
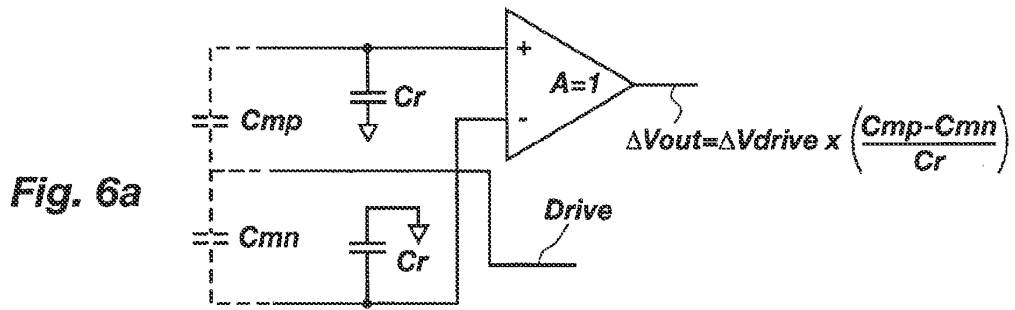

Fig. 5



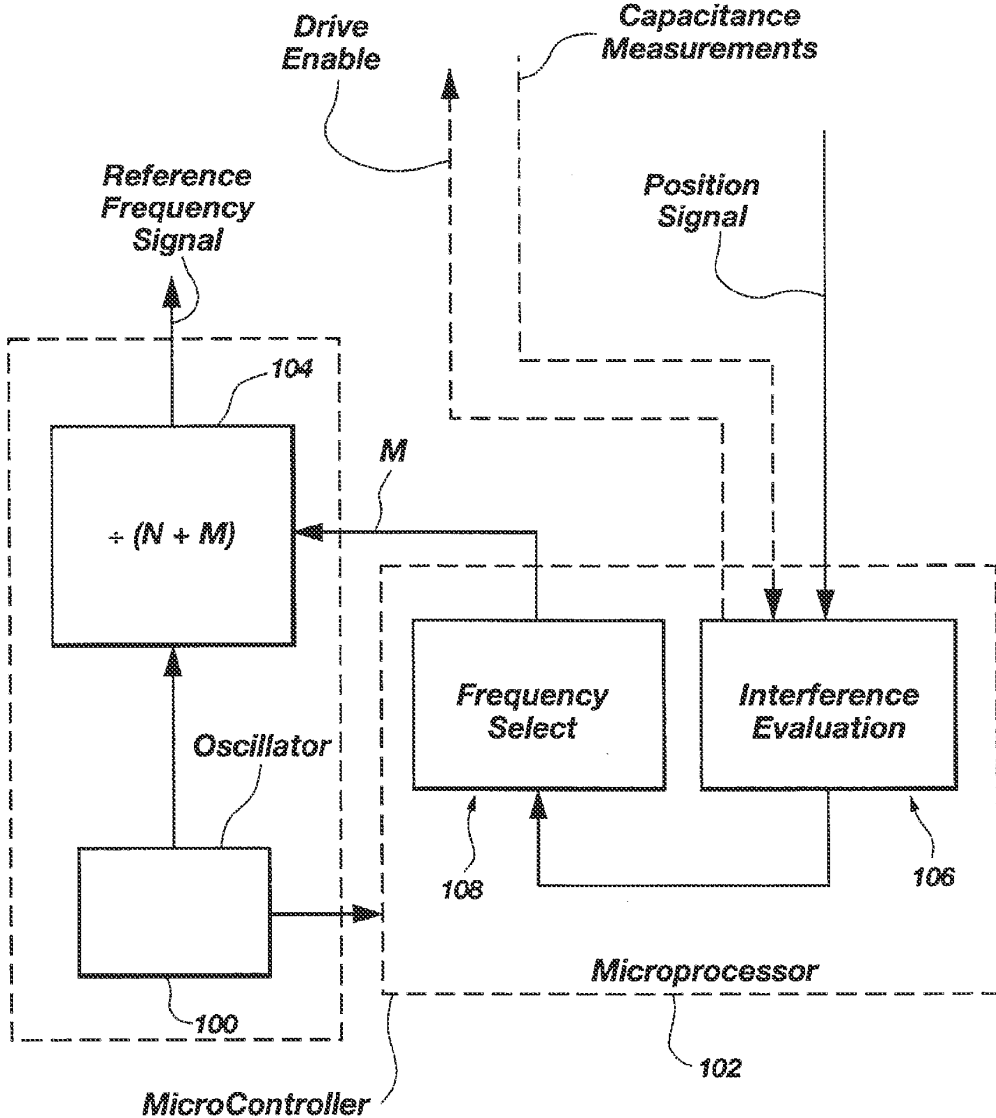

Fig. 7

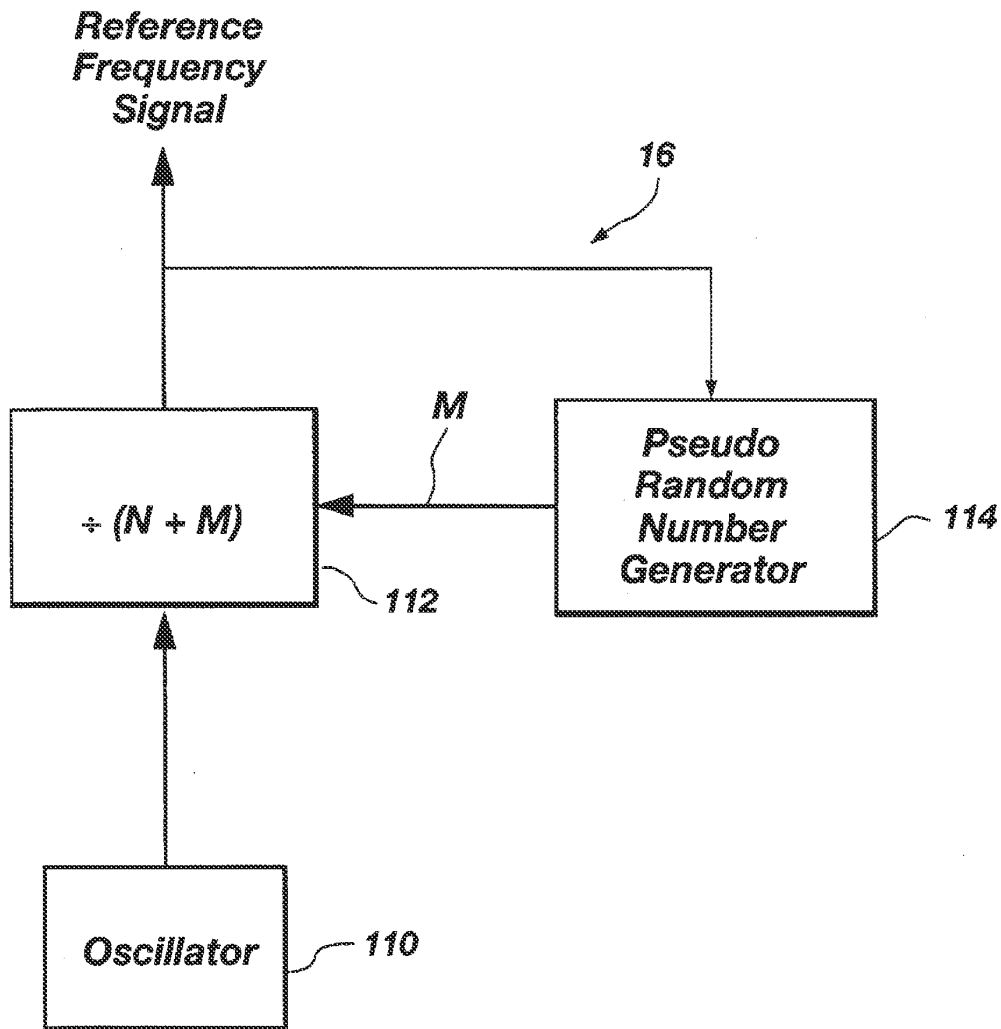

Fig. 8

CAPACITANCE-BASED PROXIMITY WITH INTERFERENCE REJECTION APPARATUS AND METHODS

The following patent is a continuation-in-part patent of U.S. patent application Ser. No. 08/193,275, filed Feb. 8, 1994, now U.S. Pat. No. 5,478,170, which is a continuation of Ser. No. 914,043, filed Jul. 13, 1992, now U.S. Pat. No. 5,305,017.

This invention relates generally to apparatus and methods for touch sensitive input devices, and more particularly, to apparatus and methods for capacitance-based touch detection wherein electrical interference is effectively rejected from the detection system.

BACKGROUND OF THE INVENTION

Numerous prior art devices and systems exist by which tactile sensing is used to provide data input to a data processor. Such devices are used in place of common pointing devices (such as a "mouse" or stylus) to provide data input by finger positioning on a pad or display device. These devices sense finger position by a capacitive touch pad wherein scanning signals are applied to the pad and variations in capacitance caused by a finger touching or approaching the pad are detected. By sensing the finger position at successive times, the motion of the finger can be detected. This sensing apparatus has application for controlling a computer screen cursor. More generally it can provide a variety of electrical equipment with information corresponding to finger movements, gestures, positions, writing, signatures and drawing motions.

In U.S. Pat. No. 4,698,461, Meadows et al., a touch surface is covered with a layer of invariant resistivity. Panel scanning signals are applied to excite selected touch surface edges so as to establish an alternating current voltage gradient across the panel surface. When the surface is touched, a touch current flows from each excited edge through the resistive surface and is then coupled to a user's finger (by capacitance or conduction), through a user's body, and finally coupled by the user's body capacitance to earth ground potential. Different scanning sequences and modes of voltage are applied to the edges, and in each case the currents are measured. It is possible to determine the location of touch by measuring these currents. In particular, the physical parameter which indicates touch location is the resistance from the edges to the point of touch on the surface. This resistance varies as the touch point is closer or farther from each edge. For this system, the term "capacitive touch pad" may be a misnomer because capacitance is involved as a means of coupling current from the surface touch point through the user's finger but is not the parameter indicative of finger position. A disadvantage of this invention is that accurate touch location measurement depends on uniform resistivity of the surface. Fabricating such a uniformly resistive surface layer can be difficult and expensive, and require special fabrication methods and equipment.

The panel of the Meadows '461 patent also includes circuitry for "nulling", or offsetting to zero, the touch currents which are present when the panel is not touched. This nulling can be accomplished while the panel operates, and allows touches which generate a relatively weak signal, such as from a gloved finger, to be more accurately determined. The Meadows '461 panel also includes circuitry for automatically shifting the frequency of panel scanning signals away from spectra of spurious signals, such as those developed by cathode-ray tube transformers, which may be

present in the environment. The panel seeks to avoid interference from the spurious signals, which could happen if the frequency of scanning was nearly equal to that of the spurious signals. A microcontroller determines whether the scanning frequency should be shifted by monitoring the rate at which adjustments are required in nulling of the touch currents, as described above. The only means described for generating frequency control signals is based on this nulling adjustment.

U.S. Pat. No. 4,922,061, Meadows et al., is similar to the Meadows '461 patent in that the touch panel determines touch location based on variations in resistance, not capacitance. This is particularly evident from FIG. 2 where the resistances from edge to touch point are shown as Kx times R_x , where Kx corresponds to the distance indicated by 76A. The apparatus uses a measurement signal of a frequency that varies in a substantially random manner, thus reducing susceptibility to interference from spurious electromagnetic spectra.

U.S. Pat. No. 4,700,022, Salvador, describes an array of detecting conductive strips, each laid between resistive emitting strips. The finger actually makes electrical contact from an emitting strip to detecting strip. Touch location is determined from resistance variation (as with Meadows '461 and '061 above) in the strip contacted by the finger. Averages are taken of a certain number of synchronous samples. A design formula is presented to choose a sampling frequency so that it is not a multiple of the most undesired predetermined interfering signal. No suggestion is made that sampling frequency is adjusted or adapts automatically.

In U.S. Pat. No. 5,305,017, Gerpheide, touch location is determined by true capacitance variation, instead of resistance variation, using a plurality of electrode strips forming virtual electrodes. This approach eliminates the necessity of a coating having uniform resistance across a display screen. However, such a capacitance-based detection device may suffer from electrical background interference from its surroundings, which is coupled onto the sensing electrodes and interferes with position detection. These spurious signals cause troublesome interference with the detection of finger positioning. The device operator may even act as an antenna for electrical interference which may cause a false charge injection or depletion from the detecting electrodes.

Accordingly, there is a need for a touch detection system which has the following characteristics:

- (1) the touch location is determined without the need of resistance variation so as to avoid the high cost of requiring uniform resistance during fabrication;
- (2) the touch location is measured in a manner independent of resistance of the electrodes or their connecting wiring, thus broadening the range of materials and processes which may be used for fabrication; and
- (3) electrical interference signals are rejected and eliminated from the detection system regardless of their frequency and without requiring possibly expensive nulling apparatus.

SUMMARY OF THE INVENTION

The present invention employs a touch location device having true capacitance variation by using insulated electrode arrays to form virtual electrodes. The capacitance variation is measured by means independent of the resistance of the electrodes, so as to eliminate that parameter as a fabrication consideration. The electrical interference is eliminated regardless of frequency to provide a clear detec-

3

tion signal.

An illustrative embodiment of the present invention includes an electrode array for developing capacitances which vary with movement of an object (such as finger, other body part, conductive stylus, etc.) near the array, a synchronous capacitance measurement element which measures variation in the capacitances, such measurements being synchronized with a reference frequency signal, and a reference frequency signal generator for generating a reference frequency signal which is not coherent with electrical interference which could otherwise interfere with capacitance measurements and thus position location.

Interference rejection is carried out by generating a reference frequency signal whose frequency is different from the interference frequency. Alternately, the reference signal is generated with random frequencies so as not to be coherent with the interference frequencies and thus the electrical interference is effectively rejected.

BRIEF DESCRIPTION OF THE DRAWINGS

FIG. 1 is a block diagram of a capacitance variation position measuring device made in accordance with the principles of the present invention;

FIG. 2A is a plan view of one illustrative embodiment of the electrode array shown in FIG. 1;

FIG. 2B is a side, cross-sectional view of one illustrative embodiment of the electrode array of FIG. 2A;

FIG. 3A is a side, cross-sectional view of another embodiment of the electrode array of FIG. 1;

FIG. 3B is a plan view of the electrode array of FIG. 3A;

FIG. 4 is a schematic of one embodiment of the synchronous electrode capacitance measurement device of FIG. 1;

FIG. 5 is a schematic of another embodiment of the synchronous electrode capacitance measurement device of FIG. 1;

FIGS. 6A-6D are circuit diagrams of alternative embodiments of the capacitance measurement elements shown in FIGS. 4 and 5;

FIG. 7 is a block diagram of one embodiment of the reference frequency generator shown in FIG. 1; and

FIG. 8 is a block diagram showing an alternative embodiment of the reference frequency generator shown in FIG. 1.

DETAILED DESCRIPTION OF PREFERRED EMBODIMENTS

FIG. 1 shows the essential elements of a capacitance variation finger (or other conductive body or non-body part) position sensing system 10, made in accordance with the invention. An electrode array 12 includes a plurality of layers of conductive electrode strips. The electrodes and the wiring connecting them to the device may have substantial resistance, which permits a variety of materials and processes to be used for fabricating them. The electrodes are electrically insulated from one another. Mutual capacitance exists between each two of the electrodes, and stray capacitance exists between each of the electrodes and ground. A finger positioned in proximity to the array alters these mutual and stray capacitance values. The degree of alteration depends on the position of the finger with respect to electrodes. In general, the alteration is greater when the finger is closer to the electrode in question.

4

A synchronous electrode capacitance measurement unit 14 is connected to the electrode array 12 and determines selected mutual and/or stray capacitance values associated with the electrodes. To minimize interference, a number of measurements are performed by unit 14 with timing synchronized to a reference frequency signal provided by reference frequency generator 16. The desired capacitance value is determined by integrating, averaging, or in more general terms, by filtering the individual measurements made by unit 14. In this way, interference in the measurement is substantially rejected except for spurious signals having strong frequency spectra near the reference frequency.

The reference frequency generator 16 attempts to automatically select and generate a reference frequency which is not coherent with the most undesirable frequency of spurious signals. This approach substantially eliminates interference even though its frequency is likely to be initially unknown and may even change during operation.

A position locator 18 processes the capacitance measurement signal from the synchronous electrode capacitance measurement unit 14 and provides position signals for use by a host computer, for example, and to the reference frequency generator 16. The position locator unit 18 determines finger position signals based on the capacitance measurements. Several different systems are commonly known in the art for determining finger position based on measurements of capacitance associated with electrodes in an array. Position locators may provide one-dimensional sensing (such as for a volume slider control), two-dimensional sensing with contact determination (such as for computer cursor control), or full three-dimensional sensing (such as for games and three-dimensional computer graphics.) An example of a prior art position locator unit is shown in the Gerpheide '017 patent mentioned above, as units 40 and 50 of FIG. 1 of the patent.

Electrode Array

FIG. 2A illustrates the electrodes in a preferred electrode array 12, together with a coordinate axes defining X and Y directions. One embodiment includes sixteen X electrodes and twelve Y electrodes, but for clarity of illustration, only six X electrodes 20 and four Y electrodes 22 are shown. It is apparent to one skilled in the art how to extend the number of electrodes. The array is preferably fabricated as a multilayer printed circuit board 24. The electrodes are etched electrically conductive strips, connected to vias 26 which in turn connect them to other layers in the array. Illustratively, the array 12 is approximately 65 millimeters in the X direction and 49 millimeters in the Y direction. The X electrodes are approximately 0.7 millimeters wide on 3.3 millimeter centers. The Y electrodes are approximately three millimeters wide on 3.3 millimeter centers.

FIG. 2b illustrates the electrode array 12 from a side, cross-sectional view. An insulating overlay 21 is an approximately 0.2 millimeters thick clear polycarbonate sheet with a texture on the top side which is comfortable to touch. Wear resistance may be enhanced by adding a textured clear hard coating over the top surface. The overlay bottom surface may be silk-screened with ink to provide graphics designs and colors.

The X electrodes 20, Y electrodes 22, ground plane 25 and component traces 27 are etched copper traces within a multilayer printed circuit board. The ground plane 25 covers the entire array area and shields the electrodes from elec-

trical interference which may be generated by the parts of the circuitry. The component traces 27 connect the vias 26 and hence the electrodes 20, 22, to other circuit components of FIG. 1. Insulator 31, insulator 32 and insulator 33 are fiberglass-epoxy layers within the printed circuit board 24. They have respective thicknesses of approximately 1.0 millimeter, 0.2 millimeters and 0.1 millimeters. Dimensions may be varied considerably as long as consistency is maintained. However, all X electrodes 20 must be the same size, as must all Y electrodes 22.

One skilled in the art will realize that a variety of techniques and materials can be used to form the electrode array. For example, FIG. 3A illustrates an alternative embodiment in which the electrode array includes an insulating overlay 40 as described above. Alternate layers of conductive ink 42 and insulating ink 43 are applied to the reverse surface by a silk screen process. The X electrodes 45 are positioned between the insulating overlay 40 and X electrode conductive ink layer 42. Another insulating ink layer 43 is applied below layer 42. The Y electrodes 46 are positioned between insulating ink layer 43 and conductive ink layer 44. Another insulating ink layer 47 is applied below conductive ink layer 44, and ground plane 48 is affixed to Y electrode conductive ink layer 47. Each layer is approximately 0.01 millimeters thick.

The resulting array is thin and flexible, which allows it to be formed into curved surfaces. In use it would be laid over a strong, solid support. In other examples, the electrode array may utilize a flexible printed circuit board, such as a flex circuit, or stampings of sheet metal or metal foil.

A variety of electrode geometries and arrangements are possible for finger position sensing. One example is shown in FIG. 3b. This is an array of parallel electrode strips 50 for one-dimensional position sensing which could be useful as a "slider volume control" or "toaster darkness control". Other examples include a grid of diamonds, or sectors of a disk.

It is desired that the electrode array of the present invention be easily fabricated by economical and widely available printed circuit board processes. It is also desired to allow use of various overlay materials selected for texture and low friction, upon which logo art work and coloration can be economically printed. A further preference is that the overlay may be custom printed separately from fabrication of the electrode-containing part of the array. This allows an economical standardized mass production of that part of the array, and later affixing of the custom printed overlay.

Synchronous Electrode Capacitance Measurement

FIG. 4 shows one embodiment of the synchronous electrode capacitance measurement unit 14 in more detail. The key elements of the synchronous electrode capacitance measurement unit 14 are (a) an element for producing a voltage change in the electrode array synchronously with a reference signal, (b) an element producing a signal indicative of the displacement charge thereby coupled between electrodes of the electrode array, (c) an element for demodulating this signal synchronously with the reference signal, and (d) an element for low pass filtering the demodulated signal. Unit 14 is coupled to the electrode array, preferably through a multiplexor or switches. The capacitances to be measured in this embodiment are mutual capacitances between electrodes but could be stray capacitances of electrodes to ground or algebraic sums (that is sums and differences) of such mutual or stray capacitances.

FIG. 4 shows one specific embodiment of a synchronous electrode capacitance measurement unit 14 connected to the electrode array 12, in which algebraic sums of mutual capacitances between electrodes are measured. The components are grouped into four main functional blocks. A virtual electrode synthesis block 70 connects each of the X electrodes to one of the wires CP or CN, and each of the Y electrodes to one of the wires RP or RN. The electrodes are selectively connected to the wires by switches, preferably CMOS switches under control of the position locator apparatus 18 (FIG. 1) to select appropriate electrodes for capacitance measurement. (See Gerpheide '017 which describes such electrode selection by signal S of FIG. 1 of the patent.) All electrodes connected to the CP wire at any one time are considered to form a single "positive virtual X electrode". Similarly, the electrodes connected to CN, RP, and RN form a "negative virtual X electrode", a "positive virtual Y electrode", and a "negative virtual Y electrode", respectively.

The reference frequency signal is preferably a digital logic signal from the reference frequency generator 16 (FIG. 1). The reference frequency signal is supplied to unit 14 via an AND gate 72 also having a "drive enable" input, supplied by the reference frequency generator 16 (FIG. 1). The AND gate output feeds through inverter 74 and noninverting buffer 76 to wires RP and RN respectively which are part of a capacitive measurement element 78. In the preferred embodiment, the drive enable signal is always TRUE, to pass the reference frequency signal. In further preferred embodiments, it is asserted FALSE by the reference frequency generator when interference evaluation is to be performed as described later. When the drive enable signal is FALSE, the drive signal stays at a constant voltage level. When the drive signal is TRUE, it is a copy of the reference frequency signal.

The capacitance measurement element 78 contains a differential charge transfer circuit 80 as illustrated in FIG. 4 of Gerpheide, U.S. Pat. 5,349,303, incorporated herein by reference. Capacitors Cs1 and Cs2 of FIG. 4 of that patent correspond to the stray capacitances of the positive and negative virtual electrodes to ground. The CHOP signal of that FIG. 4 is conveniently supplied in the present invention as a square wave signal having half the frequency of the reference frequency signal, as generated by the divide-by-2 circuit 81 shown herein. As described in the Gerpheide '303 patent, the circuit maintains CP and CN (lines 68 and 72 therein) at a constant virtual ground voltage.

The capacitance measurement element 78 also contains a non-inverting drive buffer 76 which drives RN and negative virtual Y electrodes to change voltage levels copying the drive enable signal transitions. The inverting buffer 74 drives RP and the positive virtual Y electrodes to change voltage levels opposite the drive enable signal transitions. Since CP and CN are maintained at virtual ground, these voltage changes are the net voltage changes across the mutual capacitances which exist between virtual Y and virtual X electrodes. Charges proportional to these voltage changes multiplied by the appropriate capacitance values are thereby coupled onto nodes CP and CN (the "coupled charges"). The charge transfer circuit therefore supplies a proportional differential charges at outputs Qo1 and Qo2, which are proportional to the coupled charges and thus to the capacitances.

In short, this differential charge is a proportionality factor K times the "balance" L, which is a combination of these capacitances given by the equation:

$$L=M(xp,yn)+M(xn,yp)-M(xp,yp)-M(xn,yn)$$

where M(a,b) is the notation for the mutual capacitance between virtual electrode "a" and virtual electrode "b". Changes in balance are indicative of finger position relative to virtual electrode position as described in Gerpheide, U.S. Pat. No. 5,305,017. The proportionality factor K has a sign which is the same as the drive enable signal transition direction.

Referring again to FIG. 4, the synchronous electrode capacitance measurement element 78 is connected via lines carrying charges Qo1 and Qo2 to a synchronous demodulator 82 which may be a double-pole double-throw CMOS switch 84 controlled by the reference frequency signal. The synchronous demodulator 82, which among other things functions to rectify the charges Qo1 and Qo2, is connected to a low-pass filter 86 which may be a pair of capacitors C1, C2 configured as an integrator for differential charges. (An integrator illustratively is a low pass filter with 6 db per octave frequency roll off.) Charges Qo1 and Qo2 are integrated onto capacitors C1 and C2, respectively, when the reference frequency signal has just transitioned positive, and K is positive. The charges are integrated onto opposite capacitors when K is negative. In this way, a differential charge proportional to the balance L is accumulated on C1 and C2.

FIG. 5 shows another embodiment of the synchronous electrode capacitance measurement unit 14. In this embodiment, each electrode in an electrode array 90 is connected to a dedicated capacitance measurement element 92, each of which is connected to a synchronous demodulator 94 and then to a low pass filter 96. This configuration has the advantage of continuously providing capacitance measurements for each electrode, whereas the prior preferred embodiment measures a single configuration of electrodes at any one time. The disadvantage of the embodiment of FIG. 5 is the greater expense which may be associated with the duplicated elements. This is a common tradeoff between providing multiple elements to process measurements at the same time versus multiplexing a single element to process measurements sequentially. There is obviously a wide spectrum of variations applying this trade off.

Also, many of the elements can be implemented in digital form using analog-digital converters and digital signal processing. While the preferred embodiments currently use substantial analog processing, future digital processing costs may be expected to become relatively cheaper.

FIG. 6 provides a number of preferred alternatives for the capacitance measurement element 78 (FIG. 4) or 92 (FIG. 5). FIGS. 6A and 6B show circuits adapted for measuring mutual capacitances between electrodes (which may be physical or virtual electrodes), represented by Cmp, Cmn, and Cm. FIGS. 6C and 6D show circuits adapted for measuring electrode capacitance to ground represented by Cg. Each of these provides an output voltage change indicative of the capacitance being measured. These voltage changes are given by the following formulas:

For FIG. 6A:

$$\Delta Vout=\Delta Vdrive \times (Cmp-Cmn)/Cr$$

For FIG. 6B:

$$\Delta Vout=\Delta Vdrive \times Cm/Cr$$

For FIG. 6C:

$$\Delta Vout=\Delta Vdrive \times Cg/(Cg+Cr)$$

For FIG. 6D:

$$\Delta Vout=\Delta Vdrive \times (Cg+Cr)/Cg$$

The formulas depend on a known reference capacitance represented by Cr and a known drive voltage change represented by ΔVdrive. Further capacitance measurement elements may be based on charge balance techniques as described in Meyer, U.S. Pat. No. 3,857,092. Synchronous demodulators may be implemented using an analog or digital multiplier, or a "double-balanced mixer" integrated circuit (such as part number LM1496) from National Semiconductor Company. There are different implementations known in the art for low pass filter elements, such as switched capacitor integrators and filters, high-order analog filters, and digital filters.

Reference Frequency Generator

FIG. 7 illustrates a preferred embodiment of reference frequency generator 16 (FIG. 1). The generator observes position signals to evaluate the extent of interference at some reference frequency. In the event that substantial interference is detected, the generator 16 selects a different reference frequency for further measurements. The generator 16 seeks to always select a reference frequency away from frequencies which have been found to result in measurement interference, as described below.

The generator 16 includes an oscillator 100 which is, for example, set at four MHz, driving a microcontroller 102 and a divide-by-(M+N) circuit 104. Value N is a fixed constant, approximately 50. Value M is specified by the microcontroller 102 to be, for example, one of four values in the range 61 KHz to 80 KHz as specified by the microcontroller 102.

The microcontroller 102 performs the functions of interference evaluation 106 and frequency selection 108. It may perform other functions associated with the system such as position location. The preferred interference evaluation function 106 produces a measure of the interference in the position signals generated by the position location unit 18 (FIG. 1). This is based on the principle that interference produces a spurious, relatively large magnitude high-frequency component of a position signal, and operates according to the following code description. It assumes position data points X, Y, and Z occur approximately every ten milliseconds. In brief, it calculates an interference measure, IM, as the sum of the absolute values of the second differences of X and Y together with the absolute values of the first differences of Z over 32 data points. Differencing a stream of data has the effect of applying a high-pass filter to it.

In detail, for each data point the interference evaluation function 106 executes the following steps, where ABS() means the absolute value function:

```

XD=X-XLAST ;computes first differences
YD=Y-YLAST
ZD=Z-ZLAST
XDD=XD-XDLAST ;computes second differences
YDD=YD-YDLAST
IM = IM + ABS(XDD) + ABS(YDD) + ABS(ZD) ;sum
IF EVERY 32ND SAMPLE
{EXECUTE FREQUENCY SELECT FUNCTION 108
(See description below)
IM = 0}
    
```

```

XLAST=X           ;move current values to last
YLAST=Y
ZLAST=Z
XDLAST=XD
YDLAST=YD

```

In another embodiment, the interference evaluation function 106 is not based on position signals. Instead the function asserts the drive enable signal described above to a FALSE state and reads a resulting synchronous capacitance measurement. This measures charge coupled to the electrodes when no voltage is being driven across the electrodes by the apparatus. Such charge must be the result of interference, and so this interference (from spurious signals) is directly measured. This is another way to generate the interference measure, IM.

The preferred frequency select function 108 generates a table of historical interference measurements for each frequency which may be selected. On system initialization, each entry is set to zero. Thereafter, the frequency select function is activated approximately every 32 data points by the interference evaluation function 106. The current interference measure, IM, is entered as the entry for the currently selected frequency in the table. Then all table entries are scanned. The frequency having the lowest interference measure entry is selected as the new current frequency, and the corresponding M value is sent to the divide-by-(M+N) element 104. Approximately every 80 seconds, every entry in the table is decremented by an amount corresponding to approximately 0.05 mm of position change. In this way, if a frequency is flagged as "bad" by having strong interference one time, it will not be flagged as "bad" permanently.

The functions described above for the different embodiments could be carried out by a microprocessor such as part no. MC 68HC705P6 manufactured by Motorola, Inc. serving as the microcontroller 102.

FIG. 8 shows an alternate preferred embodiment of the reference frequency generator 16 (FIG. 1). It generates a reference frequency signal that varies randomly. Each cycle of the signal has a different and substantially random period. It is extremely unlikely that a spurious signal would coherently follow the same sequence of random variation. Hence the spurious signal is substantially rejected by capacitance measurements synchronous to the reference frequency. The degree of rejection is not as great as in the former embodiment, but the generator is simpler because interference evaluation and frequency selection functions are not needed.

The generator of FIG. 8 includes an oscillator 110 and a divide-by-(N+M) circuit 112. The value M supplied to the divider comes from a pseudo-random number generator (PRNG) 114 which generates numbers in the range 0 to 15. Each cycle of the reference frequency clocks the PRNG 114 to produce a new number. PRNGs are well known in the art.

For either embodiment in FIGS. 7 or 8, the range of values for M in relation to the value of N can be increased or decreased to give a greater or lesser range of possible frequencies. The value of N or the oscillator frequency can be adjusted to change the maximum possible frequency. A phase-locked frequency synthesizer such as the Motorola MC145151-2, or a voltage controlled oscillator driven by a D/A converter, could also preferably be employed instead of the divide-by-(M+N) circuit.

It should be understood that other variations of the preferred embodiments described above fall within the scope of this invention. Such variations include different

electrode array geometry, such as a grid of strips, a grid of diamonds, parallel strips and various other shapes. Also included are different variations of electrode array fabrication, such as printed circuit board (PCB), flex PCB, silk screen, sheet or foil metal stampings. Variations of the kinds of capacitance utilized are included, such as full balance (see Gerpheide '017), stray, mutual, half balance.

The above description has provided certain preferred embodiments in accordance with this invention. It is apparent by those skilled in the art that various modifications can be made within the spirit and scope of the invention, which are included within the scope of the following claims.

What is claimed is:

1. A capacitance-based proximity sensor for locating the position of an object while rejecting a frequency of electrical interference, comprising:

(a) an electrode array for forming capacitances which vary with movements of the object,

(b) measurement means coupled to the electrode array for measuring the capacitances synchronously with a reference signal, and

(c) generator means for supplying a reference signal to the measurement means, said reference signal having a frequency which is not coherent with the frequency of electrical interference, wherein the generator means comprises means for evaluating the electrical interference and for producing the reference signal, and wherein the evaluating means includes means for storing a table of frequencies of selected reference signals and measures of electrical interference IM for each of these frequencies, and for producing a reference signal whose frequency has the lowest IM associated therewith.

2. A capacitance-based proximity sensor for locating the position of an object while rejecting electrical interference, comprising:

(a) an electrode array for forming capacitances which vary with movements of the object,

(b) measurement means coupled to the electrode array for measuring the capacitances synchronously with a reference signal,

(c) object locator means responsive to the measurement means for producing a position signal, having a high frequency component, indicating the position of the object relative to the electrode array,

(d) generator means for supplying a reference signal to the measurement means, said reference signal having a frequency which is not coherent with the frequency of the electrical interference, and wherein said generator means comprises

evaluation means responsive to the object locator means for determining the magnitude of the high frequency component of the position signal, and means responsive to the evaluation means for changing the frequency of the reference signal when the magnitude of the high frequency component of the position signal exceeds a predetermined value.

3. A capacitance-based proximity sensor for locating the position of an object while rejecting electrical interference, comprising:

(a) an electrode array for forming capacitances which vary with movements of the object,

(b) measurement means coupled to the electrode array for measuring the capacitances synchronously with a reference signal, wherein said measurement means comprises

11

driver means for developing, synchronously with the reference signal, voltage changes on the electrode array,

charge measuring means for measuring, synchronously with the reference signal, charges coupled to the electrode array and thus capacitance,

means for selectively inhibiting the driver means from developing voltage changes, the coupled charge measurements made during inhibition of the driver means representing the interference measure IM, and

(c) generator means for supplying a reference signal to the measurement means, said reference signal having a frequency which is not coherent with the frequency of the electrical interference, wherein said generator means includes means for changing the frequency of the reference signal when the interference measure IM exceeds a predetermined level.

4. The proximity sensor as in claim 3 wherein the generator means further includes means for storing a table of frequencies of reference signals and associated interference measures IM made for reference signals with each of such frequencies, and for producing a reference signal whose frequency has the lowest interference measure IM associated therewith.

5. A capacitance-based proximity sensor for locating the position of an object while rejecting electrical interference, comprising:

(a) an electrode array for forming capacitances which vary with movements of the object, wherein the electrode array comprises a plurality of first electrode strips spaced apart from each other in a first array, and a plurality of second electrode strips spaced apart from each other and in close proximity with the first electrode strips;

(b) measurement means coupled to the electrode array for measuring the capacitances synchronously with a reference signal, and

(c) generator means for supplying a reference signal to the measurement means, said reference signal having a frequency which is not coherent with the frequency of the electrical interference.

6. The proximity sensor of claim 5 wherein the measurement means includes

driver means for developing, synchronously with the reference signal, voltage changes on the electrode array,

a charge transfer means coupled to the electrode array for producing synchronously with the frequency of the reference signal, measurement signals representing charges coupled onto the electrode array as a result of the voltage changes,

12

synchronous demodulator means coupled to the charge transfer means for rectifying the measurement signals synchronously with the reference signal, and

low pass filter means coupled to the synchronous demodulator means for producing signals representing the average DC values of the rectified signals, and thus representing the capacitances of the electrode array.

7. The proximity sensor of claim 6 wherein the measurement means includes a plurality of capacitance measurement elements, each being connected to a respective electrode strip.

8. The proximity sensor of claim 7 further comprising a plurality of synchronous demodulation elements, each connected to a respective capacitance measurement element.

9. The proximity sensor of claim 1 further including a position locator means connected to the output of the measurement means for providing a position signal representative of the location of the object relative to the electrode array.

10. The detection system of claim 1 wherein the electrode array comprises first and second electrode sets spaced from each other to develop a capacitance for the touch pad.

11. The detection system of claim 10 wherein the first and second set of electrodes are generally orthogonal to each other to form virtual electrodes to provide capacitance.

12. The detection system of claim 1 wherein the measuring means comprises a capacitive measurement element coupled to the electrode array, a synchronous demodulator coupled to the capacitive measurement element, and a low-pass filter coupled to the demodulator.

13. A method of sensing the position of an object on an electrode array comprising the steps of:

(a) generating capacitances on the array which vary with movement of the object,

(b) measuring the capacitances on the array synchronously with the frequency of a reference signal, and

(c) generating a reference signal having a frequency which is not coherent with the frequencies of the electrical interference affecting the capacitances by evaluating the electrical interference, storing a table of frequencies of selected reference signals and measures of electrical interference IM for each of these frequencies, and for producing a reference signal whose frequency has the lowest IM associated therewith.

14. The method of claim 13 and further including producing a signal indicating the position of the object relative to the electrode array.

* * * * *

EXHIBIT E



NOW... THE INVISIBLE CASIO CALCULATOR WATCH

Finger-write your figures on the watch face.

Introducing the timepiece that adds another dimension to watch technology. This new CASIO combines state-of-the-art micro-computer technology with the latest styling to give you an elegant timepiece with a multitude of functions.

And the most remarkable function of all is this... The watch face actually reads and computes math problems you trace on its face.

And there's more, much more... for less than \$100.00!

ELECTRO-TOUCH TECHNOLOGY.

This handsome and superbly styled timepiece has a transparent crystal that reads finger-strokes you trace across its face. Each figure and math symbol you outline appears on the background digital display. Take your finger across twice (=) and the answer presents itself like magic.

No keys, no keyboards, no need to use stylus or pen. Even the broadest fingers will work. Add, subtract, multiply, divide — perform chain and mixed calculations to eight places, plus decimal. There's even an indicator telling you which function is being performed.

DIGITAL PRECISION. ANALOG STYLE.

This handsome CASIO was created exclusively for the man who recognizes exceptional styling. And that's what you get with this sleek new timepiece. From its raised time markers to the elegant case and band of light mesh-steel or gold-plate, this beauty has the special look of luxury that is never out of place... from the very casual to the most formal occasions.

You get the classic elegance and convenience of analog watch hands. Subtiled in the background is the modern message of digital precision. The digital display can be set

in 12-hour or 24-hour digital time. A pre-programmed calendar is set until the year 2019. It's a handsome and functional way to wear time with accuracy to 1/2 second per day.

HERE'S HOW THIS MARVEL WORKS

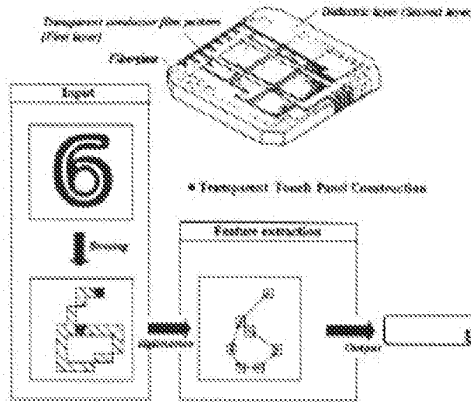

PRECISION ALARM AND STOPWATCH.

You can program this multi-talented wrist alarm for daily events. To wake you up. Catch your bus. Program it for any minute you choose. Or set it to beep-beep you every hour.

In addition to helping you organize your day, this gifted chronograph boasts a fiercely talented stopwatch. Measured normal times and net times with accuracy to 1/10 second. A beep confirms starts and stops. Ideal for tallying cooking time, minutes on your parking meter or anything you like.

WE INTRODUCE IT AND WE GUARANTEE IT.

When we first heard the engineers at CASIO were on the brink of perfecting a finger-trace recognition calculator watch, we had hopes of being the first to offer it. And now that's a reality.

Because this innovative timepiece is now available only through On The Run, to be assured earliest delivery, please order yours now. Chrome and stainless model **AT-550** is only **\$99.98** and gold-plated model **AT-550G** is **\$119.98**.

See how this handsome accessory can be worn anytime, anywhere. Discover the convenience of finger-trace calculation and all the other special features of this talented timepiece. Once you see this handsome and functional timepiece, you're sure to want to keep it. If not, we guarantee your satisfaction. Simply return it in new condition within 30 days for a full and courteous refund. One-year warranty included.

CREDIT CARD HOLDERS ORDER TOLL-FREE TODAY.

To order, call toll-free number below, or send a check of money order for the total amount plus \$2.50 for the base watch, \$1.00 for each additional watch for shipping and insurance. Add an additional \$2.00 for UPS air delivery. NC residents add 4% tax.

800-437-4385

On The Run

107 Roberts St., Department PS-2
P.O. Box 67, Fargo, ND 58107
Telephone (701) 232-9400

Call or write for a free one-year subscription to our catalog of timepieces and high-tech items for better living.

AT-650 PP-1

© 1984 ON THE RUN

IN THE UNITED STATES PATENT AND TRADEMARK OFFICE

U.S. Patent No.:	5,796,183 B1	§	Docket No.:	5796183RX2
Issued:	August 18, 1998	§	Inventors:	Hourmand et al.
Filed:	January 31, 1996	§	Patent Owner:	UUSI, LLC
Control No.	TBD	§	Examiner:	TBD

For: Capacitive Responsive Electronic Switching Circuit

Mail Stop *Ex Parte* Reexam
Attn: Central Reexamination Unit
Commissioner for Patents
P.O. Box 1450
Alexandria, VA 22313-1450

**AMENDMENT ACCOMPANYING REQUEST FOR *EX PARTE* REEXAMINATION
UNDER 35 U.S.C. §§ 302-307**

Dear Sir:

Patent Owner UUSI, LLC respectfully submits the following amendments and remarks in conjunction with its contemporaneous request for *Ex Parte* Reexamination, pursuant to the provisions of 35 U.S.C. §§ 302–307 (2002), of claims 18 and 27 of United States Patent No. 5,796,183 C1 (the “183 Patent”). The Patent Owner respectfully requests the following amendments and remarks be entered and respectfully requests consideration of amended claims 18 and 27 and newly added claims 40-105.

I. LISTING OF THE '183 PATENT CLAIMS UNDER REEXAMINATION

A listing of each claim for which reexamination has been requested is provided below. Reexamination of claims 18 and 27 is requested contemporaneously with this amendment. Accordingly, please amend claims 18 and 27 and cancel claim 35 as provided below. In addition, please add new claims 40-105 as follows.

18. (Amended) A capacitive responsive electronic switching circuit comprising:
- an oscillator providing a periodic output signal having a predefined frequency;
 - a microcontroller using the periodic output signal from the oscillator, the microcontroller selectively providing signal output frequencies, wherein a signal output frequency is selectively provided to each row of a plurality of small sized input touch terminals of a keypad;
 - the plurality of small sized input touch terminals defining adjacent areas on a dielectric substrate for an operator to provide inputs by proximity and touch; and
 - a detector circuit coupled to said oscillator for receiving said periodic output signal from said oscillator, and coupled to said input touch terminals, said detector circuit being responsive to signals from said oscillator via said microcontroller and a presence of an operator's body capacitance to ground coupled to said touch terminals when proximal or touched by the operator to provide a control output signal,
- wherein said predefined frequency of said oscillator and said signal output frequencies are selected to decrease a first impedance of said dielectric substrate relative to a second impedance of any contaminate that may create an electrical path on said dielectric substrate between said adjacent areas defined by the plurality of small sized input touch terminals, and wherein said detector circuit compares a sensed body capacitance change to ground proximate an

input touch terminal to a threshold level to prevent inadvertent generation of the control output signal.

27. (Amended) A capacitive responsive electronic switching circuit for a controlled keypad device comprising:

an oscillator providing a periodic output signal having a predefined frequency;

a microcontroller using the periodic output signal from the oscillator, the microcontroller selectively providing signal output frequencies, wherein a signal output frequency is selectively provided to each row of a closely spaced array of input touch terminals of a keypad, the input touch terminals comprising first and second input touch terminals;

the first and second input touch terminals defining areas for an operator to provide an input by proximity and touch; and

a detector circuit coupled to said oscillator for receiving said periodic output signal from said oscillator, and coupled to said first and second touch terminals, said detector circuit being responsive to signals from said oscillator via said microcontroller and a presence of an operator's body capacitance to ground coupled to said first and second touch terminals when proximal or touched by the operator to provide a control output signal for actuation of the controlled keypad device, said detector circuit being configured to generate said control output signal when the operator is proximal or touches said second touch terminal after the operator is proximal or touches said first touch terminal.

35. (Cancelled) [[The capacitive responsive electronic switching circuit as defined in claim 27, wherein when the second touch terminal is not touched on its defining area by the operator to provide input, the control output signal is prevented.]]

40. (New) The capacitive responsive electronic switching circuit as defined in claim 18, wherein each signal output frequency selectively provided to each row of the plurality of small sized input touch terminals of the keypad has a same Hertz value.

41. (New) The capacitive responsive electronic switching circuit as defined in claim 18, wherein each signal output frequency selectively provided to each row of the plurality of small sized input touch terminals of the keypad is selected from a plurality of Hertz values.

42. (New) The capacitive responsive electronic switching circuit as defined in claim 41, wherein the plurality of Hertz values comprises Hertz values greater than 50 kHz.

43. (New) The capacitive responsive electronic switching circuit as defined in claim 41, wherein the plurality of Hertz values comprises Hertz values greater than 100 kHz.

44. (New) The capacitive responsive electronic switching circuit as defined in claim 41, wherein the plurality of Hertz values comprises Hertz values greater than 800 kHz.

45. (New) A capacitive responsive electronic switching circuit comprising:
an oscillator providing a periodic output signal having a predefined frequency;
a microcontroller using the periodic output signal from the oscillator, the microcontroller selectively providing signal output frequencies directly to a plurality of small sized input touch terminals of a keypad;
the plurality of small sized input touch terminals defining adjacent areas on a dielectric substrate for an operator to provide inputs by proximity and touch; and
a detector circuit coupled to said oscillator for receiving said periodic output signal from

said oscillator, and coupled to said input touch terminals, said detector circuit being responsive to signals from said oscillator via said microcontroller and a presence of an operator's body capacitance to ground coupled to said touch terminals when proximal or touched by the operator to provide a control output signal,

wherein said predefined frequency of said oscillator and said signal output frequencies are selected to decrease a first impedance of said dielectric substrate relative to a second impedance of any contaminate that may create an electrical path on said dielectric substrate between said adjacent areas defined by the plurality of small sized input touch terminals, and wherein said detector circuit compares a sensed body capacitance change to ground proximate an input touch terminal to a threshold level to prevent inadvertent generation of the control output signal.

46. (New) The capacitive responsive electronic switching circuit as defined in claim 45, wherein the sensed body capacitance change to ground proximate the input touch terminal is caused by the operator's body capacitance decreasing an input touch terminal signal on the detector circuit, and wherein the sensed body capacitance change to ground is compared to a second threshold level to generate the control output signal.

47. (New) The capacitive responsive electronic switching circuit as defined in claim 45, wherein the sensed body capacitance change to ground proximate the input touch terminal is caused by the operator's body capacitance decreasing an input touch terminal signal amplitude on the detector circuit, and wherein the sensed body capacitance change to ground is compared to a second threshold level to generate the control output signal.

48. (New) The capacitive responsive electronic switching circuit as defined in claim 45, wherein the signal output frequencies have a same Hertz value.

49. (New) The capacitive responsive electronic switching circuit as defined in claim 45, wherein each signal output frequency is selected from a plurality of Hertz values.

50. (New) The capacitive responsive electronic switching circuit as defined in claim 49, wherein the plurality of Hertz values comprises Hertz values greater than 50 kHz.

51. (New) The capacitive responsive electronic switching circuit as defined in claim 49, wherein the plurality of Hertz values comprises Hertz values greater than 100 kHz.

52. (New) The capacitive responsive electronic switching circuit as defined in claim 49, wherein the plurality of Hertz values comprises Hertz values greater than 800 kHz.

53. (New) The capacitive responsive electronic switching circuit as defined in claim 45, wherein a peak voltage of the signal output frequencies is greater than a supply voltage.

54. (New) The capacitive responsive electronic switching circuit as defined in claim 53, wherein the supply voltage is a battery supply voltage.

55. (New) The capacitive responsive electronic switching circuit as defined in claim 53, wherein the supply voltage is a voltage regulator supply voltage.

56. (New) A capacitive responsive electronic switching circuit comprising:
an oscillator providing a periodic output signal having a predefined frequency;

a microcontroller using the periodic output signal from the oscillator, the microcontroller selectively providing signal output frequencies, wherein a signal output frequency is selectively provided to each row of a plurality of small sized input touch terminals of a keypad, and wherein a peak voltage of the signal output frequencies is greater than a supply voltage;

the plurality of small sized input touch terminals defining adjacent areas on a dielectric substrate for an operator to provide inputs by proximity and touch; and

a detector circuit coupled to said oscillator for receiving said periodic output signal from said oscillator, and coupled to said input touch terminals, said detector circuit being responsive to signals from said oscillator via said microcontroller and a presence of an operator's body capacitance to ground coupled to said touch terminals when proximal or touched by the operator to provide a control output signal,

wherein said predefined frequency of said oscillator and said signal output frequencies are selected to decrease a first impedance of said dielectric substrate relative to a second impedance of any contaminate that may create an electrical path on said dielectric substrate between said adjacent areas defined by the plurality of small sized input touch terminals, and wherein said detector circuit compares a sensed body capacitance change to ground proximate an input touch terminal to a threshold level to prevent inadvertent generation of the control output signal.

57. (New) The capacitive responsive electronic switching circuit as defined in claim 56, wherein the sensed body capacitance change to ground proximate the input touch terminal is caused by the operator's body capacitance decreasing an input touch terminal signal on the detector circuit, and wherein the sensed body capacitance change to ground is compared to a second threshold level to generate the control output signal.

58. (New) The capacitive responsive electronic switching circuit as defined in claim 56, wherein the sensed body capacitance change to ground proximate the input touch terminal is caused by the operator's body capacitance decreasing an input touch terminal signal amplitude on the detector circuit, and wherein the sensed body capacitance change to ground is compared to a second threshold level to generate the control output signal.

59. (New) The capacitive responsive electronic switching circuit as defined in claim 56, wherein each signal output frequency selectively provided to each row of the plurality of small sized input touch terminals of the keypad has a same Hertz value.

60. (New) The capacitive responsive electronic switching circuit as defined in claim 56, wherein each signal output frequency selectively provided to each row of the plurality of small sized input touch terminals of the keypad is selected from a plurality of Hertz values.

61. (New) The capacitive responsive electronic switching circuit as defined in claim 60, wherein the plurality of Hertz values comprises Hertz values greater than 50 kHz.

62. (New) The capacitive responsive electronic switching circuit as defined in claim 60, wherein the plurality of Hertz values comprises Hertz values greater than 100 kHz.

63. (New) The capacitive responsive electronic switching circuit as defined in claim 60, wherein the plurality of Hertz values comprises Hertz values greater than 800 kHz.

64. (New) The capacitive responsive electronic switching circuit as defined in claim 56, wherein the supply voltage is a battery supply voltage.

65. (New) The capacitive responsive electronic switching circuit as defined in claim 56, wherein the supply voltage is a voltage regulator supply voltage.

66. (New) The capacitive responsive electronic switching circuit as defined in claim 27, wherein each signal output frequency selectively provided to each row of the closely spaced array of input touch terminals of the keypad has a same Hertz value.

67. (New) The capacitive responsive electronic switching circuit as defined in claim 27, wherein each signal output frequency selectively provided to each row of the closely spaced array of input touch terminals of the keypad is selected from a plurality of Hertz values.

68. (New) The capacitive responsive electronic switching circuit as defined in claim 67, wherein the plurality of Hertz values comprises Hertz values greater than 50 kHz.

69. (New) The capacitive responsive electronic switching circuit as defined in claim 67, wherein the plurality of Hertz values comprises Hertz values greater than 100 kHz.

70. (New) The capacitive responsive electronic switching circuit as defined in claim 67, wherein the plurality of Hertz values comprises Hertz values greater than 800 kHz.

71. (New) The capacitive responsive electronic switching circuit as defined in claim 27, wherein the detector circuit is configured to inhibit the control output signal unless the operator is proximal or touches said second touch terminal after the operator is proximal or touches said first touch terminal.

72. (New) A capacitive responsive electronic switching circuit for a controlled keypad

device comprising:

an oscillator providing a periodic output signal having a predefined frequency;

a microcontroller using the periodic output signal from the oscillator, the microcontroller selectively providing signal output frequencies directly to a closely spaced array of input touch terminals of a keypad, the input touch terminals comprising first and second input touch terminals;

the first and second input touch terminals defining areas for an operator to provide an input by proximity and touch; and

a detector circuit coupled to said oscillator for receiving said periodic output signal from said oscillator, and coupled to said first and second touch terminals, said detector circuit being responsive to signals from said oscillator via said microcontroller and a presence of an operator's body capacitance to ground coupled to said first and second touch terminals when proximal or touched by the operator to provide a control output signal for actuation of the controlled keypad device, said detector circuit being configured to generate said control output signal when the operator is proximal or touches said second touch terminal after the operator is proximal or touches said first touch terminal.

73. (New) The capacitive responsive electronic switching circuit as defined in claim 72, wherein the signal output frequencies have a same Hertz value.

74. (New) The capacitive responsive electronic switching circuit as defined in claim 72, wherein each signal output frequency is selected from a plurality of Hertz values.

75. (New) The capacitive responsive electronic switching circuit as defined in claim 74, wherein the plurality of Hertz values comprises Hertz values greater than 50 kHz.

76. (New) The capacitive responsive electronic switching circuit as defined in claim 74, wherein the plurality of Hertz values comprises Hertz values greater than 100 kHz.

77. (New) The capacitive responsive electronic switching circuit as defined in claim 74, wherein the plurality of Hertz values comprises Hertz values greater than 800 kHz.

78. (New) The capacitive responsive electronic switching circuit as defined in claim 72, wherein said detector circuit is configured to generate said control output signal only when the operator is proximal or touches said second touch terminal within a predetermined time period after the operator is proximal or touches said first touch terminal.

79. (New) The capacitive responsive electronic switching circuit as defined in claim 72, further comprising an indicator for indicating the detector circuit has determined that the operator is proximal or touches said second touch terminal.

80. (New) The capacitive responsive electronic switching circuit as defined in claim 72, wherein the detector circuit is configured to inhibit the control output signal unless the operator is proximal or touches said second touch terminal after the operator is proximal or touches said first touch terminal.

81. (New) The capacitive responsive electronic switching circuit as defined in claim 72, wherein a peak voltage of the signal output frequencies is greater than a supply voltage.

82. (New) The capacitive responsive electronic switching circuit as defined in claim 81, wherein the supply voltage is a battery supply voltage.

83. (New) The capacitive responsive electronic switching circuit as defined in claim 81, wherein the supply voltage is a voltage regulator supply voltage.

84. (New) A capacitive responsive electronic switching circuit for a controlled keypad device comprising:

an oscillator providing a periodic output signal having a predefined frequency;

a microcontroller using the periodic output signal from the oscillator, the microcontroller selectively providing signal output frequencies to a closely spaced array of input touch terminals of a keypad, the input touch terminals comprising first and second input touch terminals, wherein a peak voltage of the signal output frequencies is greater than a supply voltage;

the first and second input touch terminals defining areas for an operator to provide an input by proximity and touch; and

a detector circuit coupled to said oscillator for receiving said periodic output signal from said oscillator, and coupled to said first and second touch terminals, said detector circuit being responsive to signals from said oscillator via said microcontroller and a presence of an operator's body capacitance to ground coupled to said first and second touch terminals when proximal or touched by the operator to provide a control output signal for actuation of the controlled keypad device, said detector circuit being configured to generate said control output signal when the operator is proximal or touches said second touch terminal after the operator is proximal or touches said first touch terminal.

85. (New) The capacitive responsive electronic switching circuit as defined in claim 84, wherein the signal output frequencies have a same Hertz value.

86. (New) The capacitive responsive electronic switching circuit as defined in claim 84, wherein each signal output frequency is selected from a plurality of Hertz values.

87. (New) The capacitive responsive electronic switching circuit as defined in claim 86, wherein the plurality of Hertz values comprises Hertz values greater than 50 kHz.

88. (New) The capacitive responsive electronic switching circuit as defined in claim 86, wherein the plurality of Hertz values comprises Hertz values greater than 100 kHz.

89. (New) The capacitive responsive electronic switching circuit as defined in claim 86, wherein the plurality of Hertz values comprises Hertz values greater than 800 kHz.

90. (New) The capacitive responsive electronic switching circuit as defined in claim 84, wherein the supply voltage is a battery supply voltage.

91. (New) The capacitive responsive electronic switching circuit as defined in claim 84, wherein the supply voltage is a voltage regulator supply voltage.

92. (New) The capacitive responsive electronic switching circuit as defined in claim 84, wherein said detector circuit is configured to generate said control output signal only when the operator is proximal or touches said second touch terminal within a predetermined time period after the operator is proximal or touches said first touch terminal.

93. (New) The capacitive responsive electronic switching circuit as defined in claim 84, further comprising an indicator for indicating the detector circuit has determined that the operator is proximal or touches said second touch terminal.

94. (New) The capacitive responsive electronic switching circuit as defined in claim 84, wherein the detector circuit is configured to inhibit the control output signal unless the operator is proximal or touches said second touch terminal after the operator is proximal or touches said first touch terminal.

95. (New) A capacitive responsive electronic switching circuit for a controlled keypad device comprising:

an oscillator providing a periodic output signal having a predefined frequency;

a microcontroller using the periodic output signal from the oscillator, the microcontroller selectively providing signal output frequencies, wherein a signal output frequency is selectively provided to each row of a closely spaced array of input touch terminals of a keypad, the input touch terminals comprising first and second input touch terminals, and wherein a peak voltage of the signal output frequencies is greater than a supply voltage;

the first and second input touch terminals defining areas for an operator to provide an input by proximity and touch; and

a detector circuit coupled to said oscillator for receiving said periodic output signal from said oscillator, and coupled to said first and second touch terminals, said detector circuit being responsive to signals from said oscillator via said microcontroller and a presence of an operator's body capacitance to ground coupled to said first and second touch terminals when proximal or touched by the operator to provide a control output signal for actuation of the controlled keypad

device, said detector circuit being configured to generate said control output signal when the operator is proximal or touches said second touch terminal after the operator is proximal or touches said first touch terminal.

96. (New) The capacitive responsive electronic switching circuit as defined in claim 95, wherein each signal output frequency selectively provided to each row of the closely spaced array of input touch terminals of the keypad has a same Hertz value.

97. (New) The capacitive responsive electronic switching circuit as defined in claim 95, wherein each signal output frequency selectively provided to each row of the closely spaced array of input touch terminals of the keypad is selected from a plurality of Hertz values.

98. (New) The capacitive responsive electronic switching circuit as defined in claim 97, wherein the plurality of Hertz values comprises Hertz values greater than 50 kHz.

99. (New) The capacitive responsive electronic switching circuit as defined in claim 97, wherein the plurality of Hertz values comprises Hertz values greater than 100 kHz.

100. (New) The capacitive responsive electronic switching circuit as defined in claim 97, wherein the plurality of Hertz values comprises Hertz values greater than 800 kHz.

101. (New) The capacitive responsive electronic switching circuit as defined in claim 95, wherein the supply voltage is a battery supply voltage.

102. (New) The capacitive responsive electronic switching circuit as defined in claim 95, wherein the supply voltage is a voltage regulator supply voltage.

103. (New) The capacitive responsive electronic switching circuit as defined in claim 95, wherein said detector circuit is configured to generate said control output signal only when the operator is proximal or touches said second touch terminal within a predetermined time period after the operator is proximal or touches said first touch terminal.

104. (New) The capacitive responsive electronic switching circuit as defined in claim 95, further comprising an indicator for indicating the detector circuit has determined that the operator is proximal or touches said second touch terminal.

105. (New) The capacitive responsive electronic switching circuit as defined in claim 95, wherein the detector circuit is configured to inhibit the control output signal unless the operator is proximal or touches said second touch terminal after the operator is proximal or touches said first touch terminal.

II. STATUS OF THE CLAIMS

Claims 1-17, 19-26, 28-34, and 36-39 are unamended with respect to the first *Ex Parte* Reexamination Certificate No. 5,796,183 C1 issued April 29, 2013. Claim 35 has been cancelled herein. Claims 18 and 27 have been amended, and claims 40-105 are newly added. The present amendment neither enlarges the scope of the claims of the patent nor introduces new matter.

III. DISCUSSION OF CLAIMS AND PRIOR ART REFERENCES

Patent Owner has filed a Request for *Ex Parte* Reexamination contemporaneously with this amendment submitting that a substantial new question of patentability of claim 18 is raised by the combination of U.S. Patent No. 5,463,388 (“Boie”) and U.S. Patent No. 5,565,658 (“Gerpheide”) and a substantial new question of patentability of claim 27 is raised by the combination of Boie, Gerpheide and the advertisement entitled “Now...The Invisible Casio Calculator Watch” (“Casio”).

Patent Owner is amending claims 18 and 27, canceling claim 35, and adding new claims 40-105 in this amendment. Accordingly, Patent Owner respectfully requests consideration of amended claims 18 and 27 and new claims 40-105. The present amendment neither enlarges the scope of the claims of the patent nor introduces new matter.

A. REFERENCES OF INTEREST

- Reference 1: Boie et al., U.S. Patent No. 5,463,388, filed on January 29, 1993 and issued on October 31, 1995 (“Boie”), which qualifies as 35 U.S.C. § 102(a)-type prior art.
- Reference 2: Gerpheide et al., U.S. Patent No. 5,565,658, filed on December 7, 1994 and issued on October 15, 1996 (“Gerpheide”), which qualifies as 35 U.S.C. § 102(e)-type prior art.
- Reference 3: Casio advertisement entitled “Now... The Invisible Casio Calculator Watch,” published in *Popular Science* by *On the Run* in 1984 (“Casio”), which qualifies as 35 U.S.C. § 102(b)-type prior art.

Reference 4: Lee, thesis entitled "A Fast Multiple-Touch-Sensitive Input Device," and published October 1984 ("Lee"), which qualifies as 35 U.S.C. § 102(b)-type prior art.

References 1-3 above are discussed in detail in the Request for *Ex Parte* Reexamination filed herewith, which discussion is incorporated herein by reference. A discussion of reference 4 (Lee) follows.

Lee generally relates to "the design and implementation of a fast-scanning multiple-touch-sensitive input device." *See, e.g.*, Lee, Abstract. Lee describes the hardware of his device as consisting of a sensor matrix board, row and column selection registers, A/D converting circuits and a dedicated CPU. *See id.* Figure 3.4, reproduced below, illustrates a block diagram of the hardware.

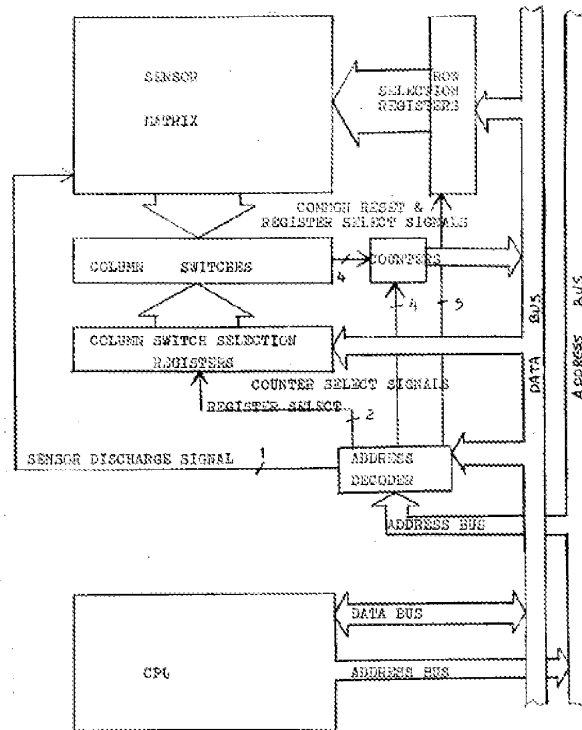

Fig. 3.4 Block diagram of the hardware.

Lee, Figure 3.4

Lee describes the operation of the row and column selection registers as follows:

The design of the sensor matrix is based on the technique of capacitance measurement between a finger tip and a metal plate. The row selection registers select one or more rows by setting the corresponding bits to a high state in order to charge up the sensors while the column selection registers select one or more columns by turn on corresponding analog switches to discharge the sensors through timing resistors. The intersecting region of the selected rows and the selected columns represents the selected sensors as a unit.

Id. at 3-1. Figure 3.1(a) shows a model of a selected sensor in the sensor matrix and Figure 3.1(b) shows the timing diagram for discharging time measurement of a selected sensor as shown in Figure 3.1(a). Figure 3.2 illustrates a small section of a sensor matrix according to Lee.

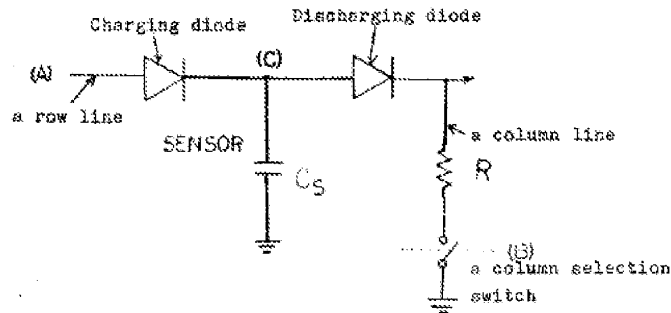

Fig. 3.1 a. A model of a selected sensor in the sensor matrix

Lee, Figure 3.1(a)

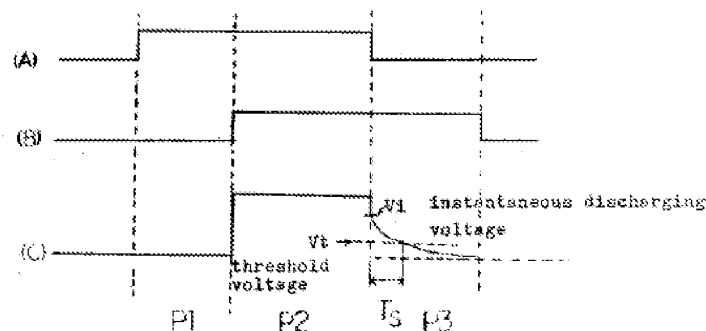

Fig. 3.1 b. The timing diagram for discharging time measurement of a selected sensor as shown above.

Lee, Figure 3.1(b)

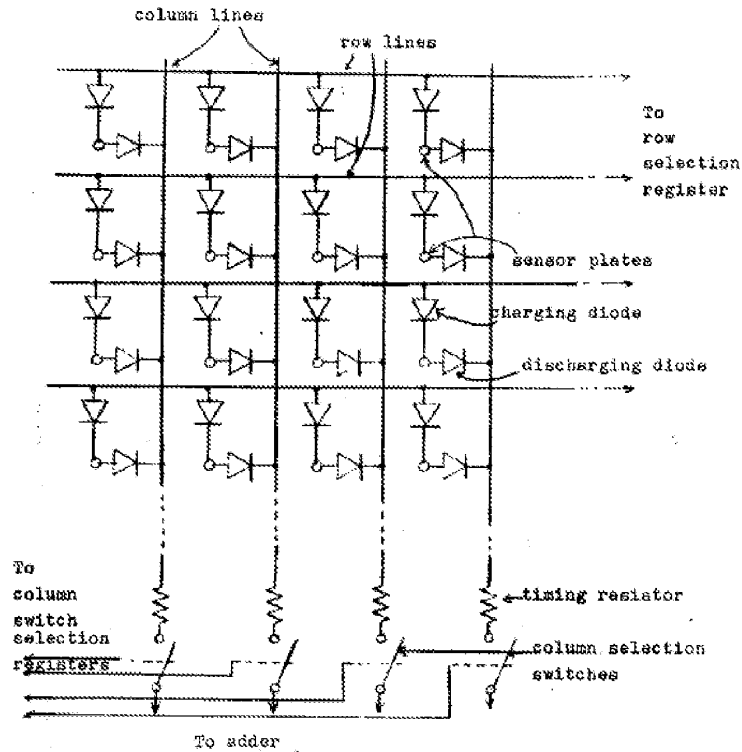

Fig. 3.2 A small section of sensor matrix.

Lee, Figure 3.2

Lee describes the interface between the CPU and the sensor matrix as follows:

The CPU selects the row or rows of a sensor group, initiating charging of all the associated sensors. After a charging interval, the CPU discharges the selected column or columns corresponding to a sensor group by connecting a group of discharge resistors whose current is summed via a high slew rate operational amplifier.

Id. at 3-10. As illustrated by the data bus of Figure 3.4, Lee teaches the CPU selects or deselects the row(s) by sending binary signals to the selected row(s). *See, e.g., id.* at Figs. 3.1(a), 3.1(b), and 3.4. Lee does not disclose sending frequencies to the selected rows.

B. DISCUSSION OF CLAIMS

Independent Claim 18

Independent claim 18 as amended herein recites “a microcontroller using the periodic output signal from the oscillator, the microcontroller selectively providing signal output frequencies, wherein a signal output frequency is selectively provided to each row of a plurality of small sized input touch terminals of a keypad.” None of the cited references, alone or in combination, teaches or suggests these limitations.

Rather, Boie discloses that “RF oscillator 408 provides an RF signal, for example, 100 kilohertz, to circuits 401, synchronous detector and filter 404 via inverter 410, and guard plane 411.” Boie, col. 3:67-col. 4:2. Boie further discloses that “[t]he effects of electrode-to-electrode capacitances, wiring capacitances and other extraneous capacitances are minimized by driving all electrodes and guard plane 411 in unison with the same RF signal from RF oscillator 408.” *Id.* at col. 4:58-60; *see id.* at Fig. 4. Thus, Boie discloses driving the electrodes of electrode array 100 and guard plane 411 with a single RF signal. Boie does not teach or suggest a microcontroller providing signal output frequencies to these components, wherein a signal output frequency is selectively provided to each row of a plurality of small sized input touch terminals of a keypad.

Neither Gerpheide nor Lee cures the deficiencies of Boie. While Gerpheide teaches a reference frequency generator 16 “observes position signals to evaluate the extent of interference at some reference frequency” and that in “the event that substantial interference is detected, the generator 16 selects a different frequency for further measurements,” Gerpheide does not teach that a microcontroller provides these frequencies selectively to each row of the input touch terminals. *See, e.g., id.* at col. 8:22-30; Fig. 7. Rather, in Gerpheide, the “reference frequency signal is supplied to unit 14 via an AND gate 72.... The AND gate output feeds through inverter 74 and noninverting buffer 76 to wires RP and RN respectively which are part of a capacitive

measurement element 78.” *See id.* at col. 6:19-26; Fig. 4. Thus, the output of AND gate 72 is sent to every row of electrode array 12 via one of inverter 74 and noninverting buffer 76 at the same time. Therefore, Gerpheide does not disclose a signal output frequency is selectively provided to each row of a plurality of small sized input touch terminals of a keypad.

Likewise, Lee does not teach or suggest that a signal output frequency is selectively provided to each row of a plurality of small sized input touch terminals of a keypad. Rather, Lee teaches the CPU selects or deselects row(s) by sending binary signals to the selected row(s). *See, e.g., id.* at Figs. 3.1(a), 3.1(b), and 3.4. In contrast, claim 18 recites selectively providing a signal output frequency to each row of the touch terminals.

Accordingly, Boie in combination with Gerpheide and/or Lee does not disclose all of the elements of claim 18, and therefore claim 18 is patentable over these references.

New claims 40-44 depend from claim 18 and add further limitations. Patent Owner respectfully submits that these dependent claims are allowable by reason of depending from an allowable claim as well as for adding new limitations.

Independent Claim 27

Independent claim 27 as amended herein recites “the microcontroller selectively providing signal output frequencies, wherein a signal output frequency is selectively provided to each row of a closely spaced array of input touch terminals of a keypad, the input touch terminals comprising first and second input touch terminals.” None of the cited references, alone or in combination, teaches or suggests these limitations.

Rather, Boie discloses that “RF oscillator 408 provides an RF signal, for example, 100 kilohertz, to circuits 401, synchronous detector and filter 404 via inverter 410, and guard plane 411.” Boie, col. 3:67-col. 4:2. Boie further discloses that “[t]he effects of electrode-to-electrode

capacitances, wiring capacitances and other extraneous capacitances are minimized by driving all electrodes and guard plane 411 in unison with the same RF signal from RF oscillator 408.” *Id.* at col. 4:58-60; *see id.* at Fig. 4. Thus Boie discloses driving the electrodes of electrode array 100 and guard plane 411 with a single RF signal. Boie does not teach or suggest the microcontroller selectively providing signal output frequencies, wherein a signal output frequency is selectively provided to each row of a closely spaced array of input touch terminals of a keypad, the input touch terminals comprising first and second input touch terminals.

None of Gerpheide, Lee or Casio cures the deficiencies of Boie. While Gerpheide teaches a reference frequency generator 16 “observes position signals to evaluate the extent of interference at some reference frequency” and that in “the event that substantial interference is detected, the generator 16 selects a different frequency for further measurements,” Gerpheide does not teach that a microcontroller provides these frequencies selectively to each row of the input touch terminals. *See, e.g., id.* at col. 8:22-30; Fig. 7. Rather, in Gerpheide, the “reference frequency signal is supplied to unit 14 via an AND gate 72.... The AND gate output feeds through inverter 74 and noninverting buffer 76 to wires RP and RN respectively which are part of a capacitive measurement element 78.” *See id.* at col. 6:19-26; Fig. 4. Thus, the output of AND gate 72 is sent to every row of electrode array 12 via one of inverter 74 and noninverting buffer 76 at the same time. Therefore, Gerpheide does not disclose a signal output frequency is selectively provided to each row of a plurality of small sized input touch terminals of a keypad.

Likewise, Lee does not teach or suggest that a signal output frequency is selectively provided to each row of a plurality of small sized input touch terminals of a keypad. Rather, Lee teaches the CPU selects or deselects row(s) by sending binary signals to the selected row(s). *See,*

e.g., id. at Figs. 3.1(a), 3.1(b), and 3.4. In contrast, claim 27 recites selectively providing a signal output frequency to each row of the touch terminals.

Casio discloses input touch terminals comprising first and second input touch terminals, *see, e.g.,* Figure, but fails to provide any teaching with respect to the microcontroller selectively providing signal output frequencies, wherein a signal output frequency is selectively provided to each row of a closely spaced array of input touch terminals of a keypad.

Accordingly, Boie in combination with Gerpheide, Lee and/or Casio does not disclose all of the elements of claim 27, and therefore claim 27 is patentable over these references.

New claims 66-71 depend from claim 27 and add further limitations. Patent Owner respectfully submits that these dependent claims are allowable by reason of depending from an allowable claim as well as for adding new limitations.

Independent Claim 45

Independent claim 45 recites “a microcontroller using the periodic output signal from the oscillator, the microcontroller selectively providing signal output frequencies directly to a plurality of small sized input touch terminals of a keypad.” None of the cited references, alone or in combination, teaches or suggests these limitations.

Rather, Boie discloses that “RF oscillator 408 provides an RF signal, for example, 100 kilohertz, to circuits 401, synchronous detector and filter 404 via inverter 410, and guard plane 411.” Boie, col. 3:67-col. 4:2. Boie further discloses that “[t]he effects of electrode-to-electrode capacitances, wiring capacitances and other extraneous capacitances are minimized by driving all electrodes and guard plane 411 in unison with the same RF signal from RF oscillator 408.” *Id.* at col. 4:58-60; *see id.* at Fig. 4. Thus, Boie discloses driving the electrodes of electrode array 100 and guard plane 411 with a single RF signal sent from oscillator 408. Therefore, Boie does not

teach or suggest a microcontroller selectively providing signal output frequencies directly to a plurality of small sized input touch terminals of a keypad.

Neither Gerpheide nor Lee cures the deficiencies of Boie. While Gerpheide teaches a reference frequency generator 16 “observes position signals to evaluate the extent of interference at some reference frequency” and that in “the event that substantial interference is detected, the generator 16 selects a different frequency for further measurements,” Gerpheide does not teach that a microcontroller provides these frequencies directly to a plurality of small sized input touch terminals. *See, e.g., id.* at col. 8:22-30; Fig. 7. Rather, in Gerpheide, the microprocessor provides value M, i.e., a selected frequency, to a divide-by-(M+N) circuit 104 which then outputs the reference frequency signal to AND gate 72. *See, e.g., id.* at col. 8:31-38; col. 6:19-26; Figs. 4 and 7. Thereafter, the output of AND gate 72 is sent to electrode array 12 via one of inverter 74 and noninverting buffer 76. *See, e.g., id.* at col. 6:19-26; Fig. 4. Therefore, Gerpheide does not disclose the microcontroller selectively providing signal output frequencies directly to a plurality of small sized input touch terminals of a keypad.

Lee does not teach or suggest that signal output frequencies are directly provided from a microcontroller to the plurality of small sized input touch terminals of a keypad. Rather, Lee teaches the CPU selects or deselects row(s) by sending binary signals to the selected row(s). *See, e.g., id.* at Figs. 3.1(a), 3.1(b), and 3.4. In contrast, claim 45 recites a microcontroller selectively provides signal output frequencies directly to the touch terminals.

Accordingly, Boie in combination with Gerpheide and/or Lee does not disclose all of the elements of claim 45, and therefore claim 45 is patentable over these references.

New claims 46-55 depend from claim 45 and add further limitations. Patent Owner respectfully submits that these dependent claims are allowable by reason of depending from an allowable claim as well as for adding new limitations.

Independent Claim 56

Independent claim 56 recites “a microcontroller using the periodic output signal from the oscillator, the microcontroller selectively providing signal output frequencies, wherein a signal output frequency is selectively provided to each row of a plurality of small sized input touch terminals of a keypad, and wherein a peak voltage of the signal output frequencies is greater than a supply voltage.” None of the cited references, alone or in combination, teaches or suggests these limitations.

As discussed above with respect to claims 18 and 27, the cited references, either alone or in combination, fail to teach or suggest the microcontroller selectively providing signal output frequencies, wherein a signal output frequency is selectively provided to each row of a plurality of small sized input touch terminals of a keypad. Moreover, none of the cited references teaches or suggests wherein a peak voltage of the signal output frequencies is greater than a supply voltage.

Accordingly, Boie in combination with Gerpheide and/or Lee does not disclose all of the elements of claim 56, and therefore claim 56 is patentable over these references.

New claims 57-65 depend from claim 56 and add further limitations. Patent Owner respectfully submits that these dependent claims are allowable by reason of depending from an allowable claim as well as for adding new limitations.

Independent Claim 72

Independent claim 72 recites “a microcontroller using the periodic output signal from the oscillator, the microcontroller selectively providing signal output frequencies directly to a closely spaced array of input touch terminals of a keypad, the input touch terminals comprising first and second input touch terminals.” None of the cited references, alone or in combination, teaches or suggests these limitations.

Rather, Boie discloses that “RF oscillator 408 provides an RF signal, for example, 100 kilohertz, to circuits 401, synchronous detector and filter 404 via inverter 410, and guard plane 411.” Boie, col. 3:67-col. 4:2. Boie further discloses that “[t]he effects of electrode-to-electrode capacitances, wiring capacitances and other extraneous capacitances are minimized by driving all electrodes and guard plane 411 in unison with the same RF signal from RF oscillator 408.” *Id.* at col. 4:58-60; *see id.* at Fig. 4. Thus, Boie discloses driving the electrodes of electrode array 100 and guard plane 411 with a single RF signal sent from oscillator 408. Therefore, Boie does not teach or suggest a microcontroller selectively providing signal output frequencies directly to a closely spaced array of input touch terminals of a keypad.

None of Gerpheide, Lee or Casio cures the deficiencies of Boie. While Gerpheide teaches a reference frequency generator 16 “observes position signals to evaluate the extent of interference at some reference frequency” and that in “the event that substantial interference is detected, the generator 16 selects a different frequency for further measurements,” Gerpheide does not teach that a microcontroller provides these frequencies directly to a closely spaced array of input touch terminals. *See, e.g., id.* at col. 8:22-30; Fig. 7. Rather, in Gerpheide, the microprocessor provides value M, i.e., a selected frequency, to a divide-by-(M+N) circuit 104 which then outputs the reference frequency signal to AND gate 72. *See, e.g., id.* at col. 8:31-38;

col. 6:19-26; Figs. 4 and 7. Thereafter, the output of AND gate 72 is sent to electrode array 12 via one of inverter 74 and noninverting buffer 76. *See, e.g., id.* at col. 6:19-26; Fig. 4.

Therefore, Gerpheide does not disclose the microcontroller selectively providing signal output frequencies directly to a closely spaced array of input touch terminals of a keypad.

Lee does not teach or suggest that signal output frequencies are directly provided from a microcontroller to the plurality of small sized input touch terminals of a keypad. Rather, Lee teaches the CPU selects or deselects row(s) by sending binary signals to the selected row(s). *See, e.g., id.* at Figs. 3.1(a), 3.1(b), and 3.4. In contrast, claim 72 recites a microcontroller selectively provides signal output frequencies directly to the touch terminals.

Casio discloses input touch terminals comprising first and second input touch terminals, *see, e.g.,* Figure, but fails to provide any teaching with respect to the microcontroller selectively providing signal output frequencies directly to a closely spaced array of input touch terminals of a keypad.

Accordingly, Boie in combination with Gerpheide, Lee and/or Casio does not disclose all of the elements of claim 72, and therefore claim 72 is patentable over these references.

New claims 73-83 depend from claim 72 and add further limitations. Patent Owner respectfully submits that these dependent claims are allowable by reason of depending from an allowable claim as well as for adding new limitations.

Independent Claim 84

Independent claim 84 recites “the microcontroller selectively providing signal output frequencies to a closely spaced array of input touch terminals of a keypad, the input touch terminals comprising first and second input touch terminals, wherein a peak voltage of the signal output frequencies is greater than a supply voltage.”

None of the cited references, alone or in combination, teaches or suggests at least wherein a peak voltage of the signal output frequencies is greater than a supply voltage. Accordingly, Boie in combination with Gerpheide, Casio and/or Lee does not disclose all of the elements of claim 84, and therefore claim 84 is patentable over these references.

New claims 85-94 depend from claim 84 and add further limitations. Patent Owner respectfully submits that these dependent claims are allowable by reason of depending from an allowable claim as well as for adding new limitations.

Independent Claim 95

Independent claim 95 recites “a microcontroller using the periodic output signal from the oscillator, the microcontroller selectively providing signal output frequencies, wherein a signal output frequency is selectively provided to each row of a closely spaced array of input touch terminals of a keypad, the input touch terminals comprising first and second input touch terminals, and wherein a peak voltage of the signal output frequencies is greater than a supply voltage.” None of the cited references, alone or in combination, teaches or suggests these limitations.

As discussed above with respect to claims 18, 27 and 56, the cited references, either alone or in combination, fail to teach or suggest a signal output frequency is selectively provided to each row of a closely spaced array of input touch terminals of a keypad. Moreover, none of the cited references teaches or suggests wherein a peak voltage of the signal output frequencies is greater than a supply voltage.

Accordingly, Boie in combination with Gerpheide, Casio and/or Lee does not disclose all of the elements of claim 95, and therefore claim 95 is patentable over these references.

New claims 96-105 depend from claim 95 and add further limitations. Patent Owner respectfully submits that these dependent claims are allowable by reason of depending from an allowable claim as well as for adding new limitations.

IV. SUPPORT FOR CLAIM AMENDMENTS AND NEW CLAIMS

Support for each of the amendments to claims 18 and 27 and for each of the new claims 40-105 may be found throughout the `183 Patent, and particular support may be found, for example, as set forth in the charts below.

A. Amended Claim 18

`183 Patent Claim Language	`183 Patent Support
18. A capacitive responsive electronic switching circuit comprising:	--
an oscillator providing a periodic output signal having a predefined frequency;	--
a microcontroller using the periodic output signal from the oscillator, the microcontroller selectively providing signal output frequencies, <u>wherein a signal output frequency is selectively provided to each row of</u> a plurality of small sized input touch terminals of a keypad;	<p>See Figures 4, 11; and Claims 8, 12, 16.</p> <p>The `183 Patent discloses “The touch detection circuit of the present invention features operation at frequencies at or above 50kHz and preferably at or above 800 kHz to minimize the effects of surface contamination from materials such a [sic] skin oils and water. It also offers improvements in detection sensitivity that allow close control of the degree of proximity (ideally very close proximity) that is required for actuation and to enable employment of a multiplicity of small sized touch terminals in a physically close array such as a keyboard.” Col. 5:49-57.</p> <p>The `183 Patent discloses “In a first preferred embodiment the circuit offers enhanced detection sensitivity to allow reliable operation with small (finger size) touch pads.” Col. 6:1-3.</p> <p>The `183 Patent discloses “Although the</p>

`183 Patent Claim Language	`183 Patent Support
	<p>preferred frequency is at or above 100 kHz, and more preferably at or above 800 kHz, it is conceivable that frequencies as low as 50 kHz could be used provided the frequency creates a difference in the impedance paths of adjacent pads that is sufficient enough to accurately distinguish between an intended touch and the touch of an adjacent pad. Use of frequencies as low as 50 kHz may also be possible depending upon the type of glass or covering or the thickness thereof used for the touch pad.” Col. 11:19-27.</p> <p>The `183 Patent discloses “Upon being powered by voltage regulator 100, oscillator 200 generates a square wave with a frequency of 50 kHz, and preferably greater than 800 kHz, and having an amplitude of 26 V peak. The square wave generated by oscillator 200 is supplied via line 201 to a floating common generator 300, a touch pad shield plate 460, a touch circuit 400, and a microcontroller 500. Oscillator 200 is described below with reference to FIG. 6. Floating common generator 300 receives the 26 V peak square wave from oscillator 200 and outputs a regulated floating common that is 5 volts below the square wave output from oscillator 200 and has the same phase and frequency as the received square wave. This floating common output is supplied to touch circuit 400 and microcontroller 500 via line 301 such that the output square wave from oscillator 200 and floating common output from floating common generator 300 provide power to touch circuit 400 and microcontroller 500. Details of floating common generator 300 are discussed below with reference to FIG. 7. Touch circuit 400 senses capacitance from a touch pad 450 via line 451 and outputs a signal to microcontroller 500 via line 401 upon detecting a capacitance to ground at touch pad 450 that exceeds a threshold value. The details of touch circuit 400 are described below with reference to FIG. 8.</p>

`183 Patent Claim Language	`183 Patent Support
	<p>Upon receiving an indication from touch circuit 400 that a sufficient capacitance to ground (typically at least 20 pF) is present at touch pad 450, microcontroller 500 outputs a signal to a load-controlling microcontroller 600 via line 501, which is preferably a two way optical coupling bus.” Col. 12:6-33.</p> <p>The `183 Patent discloses “As will be apparent to those skilled in the art, the values of the resistors and capacitors utilized in oscillator 200 may be varied from those disclosed above to provide for different oscillator output frequencies.” Col. 14:22-25.</p> <p>The `183 Patent discloses “A multiple touch pad circuit constructed in accordance with the second embodiment is shown in FIG. 11. In the second embodiment of FIG. 11, components similar to those in the first embodiment in FIG. 4 are designated with the same references numerals and will not be discussed in detail. The multiple touch pad circuit is a variation of the first embodiment in that it includes an array of touch circuits designated as 900₁ through 900_{nm}, which, as shown, include both the touch circuit 400 shown in FIGS. 4 and 8 and the input touch terminal pad 451 (FIG. 4). Microcontroller 500 selects each row of the touch circuits 900₁ to 900_{nm} by providing the signal from oscillator 200 to selected rows of touch circuits. In this manner, microcontroller 500 can sequentially activate the touch circuit rows and associate the received inputs from the columns of the array with the activated touch circuit(s). To keep the path length 451 between the touch pad 450 and the base to the detection transistor 410 to a minimum, the detection circuits 900 are physically located directly beneath the touch pads. To simplify assembly, a flexible circuit board such as vended by Sheldahl, Inc. or Circuit Etching Technics, Inc. can be used for this purpose. Ideally, the printed circuit will be fixed directly against the surface</p>

`183 Patent Claim Language	`183 Patent Support
	(typically glass) bearing the conductive touch pads to eliminate air gaps and the need for conductive foam pads and spring contacts which were used to fill air gaps.” Col. 18:34-59.
the plurality of small sized input touch terminals defining adjacent areas on a dielectric substrate for an operator to provide inputs by proximity and touch; and	--
a detector circuit coupled to said oscillator for receiving said periodic output signal from said oscillator, and coupled to said input touch terminals, said detector circuit being responsive to signals from said oscillator via said microcontroller and a presence of an operator's body capacitance to ground coupled to said touch terminals when proximal or touched by the operator to provide a control output signal,	--
wherein said predefined frequency of said oscillator and said signal output frequencies are selected to decrease a first impedance of said dielectric substrate relative to a second impedance of any contaminate that may create an electrical path on said dielectric substrate between said adjacent areas defined by the plurality of small sized input touch terminals, and wherein said detector circuit compares a sensed body capacitance change to ground proximate an input touch terminal to a threshold level to prevent inadvertent generation of the control output signal.	--

B. Amended Claim 27

`183 Patent Claim Language	`183 Patent Support
27. A capacitive responsive electronic switching circuit for a controlled keypad device comprising:	--

`183 Patent Claim Language	`183 Patent Support
<p>an oscillator providing a periodic output signal having a predefined frequency;</p>	<p>--</p>
<p>a microcontroller using the periodic output signal from the oscillator, the microcontroller selectively providing signal output frequencies, <u>wherein a signal output frequency is selectively provided to each row of</u> a closely spaced array of input touch terminals of a keypad, the input touch terminals comprising first and second input touch terminals;</p>	<p>See Figures 4, 11; and Claims 8, 12, 16.</p> <p>The `183 Patent discloses “The touch detection circuit of the present invention features operation at frequencies at or above 50 kHz and preferably at or above 800 kHz to minimize the effects of surface contamination from materials such a [sic] skin oils and water. It also offers improvements in detection sensitivity that allow close control of the degree of proximity (ideally very close proximity) that is required for actuation and to enable employment of a multiplicity of small sized touch terminals in a physically close array such as a keyboard.” Col. 5:49-57.</p> <p>The `183 Patent discloses “In a first preferred embodiment the circuit offers enhanced detection sensitivity to allow reliable operation with small (finger size) touch pads.” Col. 6:1-3.</p> <p>The `183 Patent discloses “Although the preferred frequency is at or above 100 kHz, and more preferably at or above 800 kHz, it is conceivable that frequencies as low as 50 kHz could be used provided the frequency creates a difference in the impedance paths of adjacent pads that is sufficient enough to accurately distinguish between an intended touch and the touch of an adjacent pad. Use of frequencies as low as 50 kHz may also be possible depending upon the type of glass or covering or the thickness thereof used for the touch pad.” Col. 11:19-27.</p> <p>The `183 Patent discloses “Upon being powered by voltage regulator 100, oscillator 200 generates a square wave with a frequency of 50 kHz, and preferably greater than 800 kHz, and having an amplitude of 26 V peak. The square wave generated by oscillator 200 is supplied via</p>

`183 Patent Claim Language	`183 Patent Support
	<p>line 201 to a floating common generator 300, a touch pad shield plate 460, a touch circuit 400, and a microcontroller 500. Oscillator 200 is described below with reference to FIG. 6. Floating common generator 300 receives the 26 V peak square wave from oscillator 200 and outputs a regulated floating common that is 5 volts below the square wave output from oscillator 200 and has the same phase and frequency as the received square wave. This floating common output is supplied to touch circuit 400 and microcontroller 500 via line 301 such that the output square wave from oscillator 200 and floating common output from floating common generator 300 provide power to touch circuit 400 and microcontroller 500. Details of floating common generator 300 are discussed below with reference to FIG. 7.</p> <p>Touch circuit 400 senses capacitance from a touch pad 450 via line 451 and outputs a signal to microcontroller 500 via line 401 upon detecting a capacitance to ground at touch pad 450 that exceeds a threshold value. The details of touch circuit 400 are described below with reference to FIG. 8.</p> <p>Upon receiving an indication from touch circuit 400 that a sufficient capacitance to ground (typically at least 20 pF) is present at touch pad 450, microcontroller 500 outputs a signal to a load-controlling microcontroller 600 via line 501, which is preferably a two way optical coupling bus.” Col. 12:6-33.</p> <p>The `183 Patent discloses “As will be apparent to those skilled in the art, the values of the resistors and capacitors utilized in oscillator 200 may be varied from those disclosed above to provide for different oscillator output frequencies.” Col. 14:22-25.</p> <p>The `183 Patent discloses “A multiple touch pad circuit constructed in accordance with the second embodiment is shown in FIG. 11. In the second embodiment of FIG. 11, components</p>

`183 Patent Claim Language	`183 Patent Support
	<p>similar to those in the first embodiment in FIG. 4 are designated with the same references numerals and will not be discussed in detail. The multiple touch pad circuit is a variation of the first embodiment in that it includes an array of touch circuits designated as 900₁ through 900_{nm}, which, as shown, include both the touch circuit 400 shown in FIGS. 4 and 8 and the input touch terminal pad 451 (FIG. 4). Microcontroller 500 selects each row of the touch circuits 900₁ to 900_{nm} by providing the signal from oscillator 200 to selected rows of touch circuits. In this manner, microcontroller 500 can sequentially activate the touch circuit rows and associate the received inputs from the columns of the array with the activated touch circuit(s). To keep the path length 451 between the touch pad 450 and the base to the detection transistor 410 to a minimum, the detection circuits 900 are physically located directly beneath the touch pads. To simplify assembly, a flexible circuit board such as vended by Sheldahl, Inc. or Circuit Etching Technics, Inc. can be used for this purpose. Ideally, the printed circuit will be fixed directly against the surface (typically glass) bearing the conductive touch pads to eliminate air gaps and the need for conductive foam pads and spring contacts which were used to fill air gaps.” Col. 18:34-59.</p>
<p>the first and second input touch terminals defining areas for an operator to provide an input by proximity and touch; and</p>	<p>--</p>
<p>a detector circuit coupled to said oscillator for receiving said periodic output signal from said oscillator, and coupled to said first and second touch terminals, said detector circuit being responsive to signals from said oscillator via said microcontroller and a presence of an operator's body capacitance to ground coupled to said first and second touch terminals when proximal or touched by</p>	<p>--</p>

`183 Patent Claim Language	`183 Patent Support
<p>the operator to provide a control output signal for actuation of the controlled keypad device, said detector circuit being configured to generate said control output signal when the operator is proximal or touches said second touch terminal after the operator is proximal or touches said first touch terminal.</p>	

C. New Claim 40

`183 Patent Claim Language	`183 Patent Support
<p>40. The capacitive responsive electronic switching circuit as defined in claim 18, wherein each signal output frequency selectively provided to each row of the plurality of small sized input touch terminals of the keypad has a same Hertz value.</p>	<p>See Figure 11.</p> <p>The `183 Patent discloses “The touch detection circuit of the present invention features operation at frequencies at or above 50 kHz and preferably at or above 800 kHz to minimize the effects of surface contamination from materials such a [sic] skin oils and water. Col. 5:49-53.</p> <p>The `183 Patent discloses “Conversely, at 100 kHz, the glass impedance drops to approximately 1 MΩ resulting in the impedance of the path to ground for pad 59 being twice that of the touched pad 57. For cases where background noise and temperature drifts are comparatively small, a 100 kHz oscillator frequency would allow a sufficiently low detection threshold to be set to differentiate between the signal changes induced at both pads by a human touch opposite a single pad. At 800 kHz, the impedance of the glass drops to 200 kΩ or lower giving a ratio of a greater than 5 to 1 impedance difference between the paths to ground of the touched pad 57 and adjacent pads 59. In fact, the impedance ratio may exceed 10 to 1, as illustrated in the calculation below. This allows the detection threshold for the touched pad to be set well below that of an adjacent pad resulting in a much lower incidence of inadvertent actuation of adjacent touch pads to that of the touched pad. Ideally, the frequency of operation would be kept at the 800 kHz of the</p>

`183 Patent Claim Language	`183 Patent Support
	<p>preferred embodiment or even higher. However, as noted earlier, higher frequency operation forces the use of more expensive components and designs. For applications where thermal drift and electronic noise levels are low, operation at or near 100 kHz may be possible. However, at 10 kHz and below, the impedance of the glass becomes much greater than that of likely water bridges between pads resulting in adjacent pads being effected as much by a touch as the touched pad itself. Although the preferred frequency is at or above 100 kHz, and more preferably at or above 800 kHz, it is conceivable that frequencies as low as 50 kHz could be used provided the frequency creates a difference in the impedance paths of adjacent pads that is sufficient enough to accurately distinguish between an intended touch and the touch of an adjacent pad. Use of frequencies as low as 50 kHz may also be possible depending upon the type of glass or covering or the thickness thereof used for the touch pad. Col. 10:60 – Col. 11:27.</p> <p>The `183 Patent discloses “As will be apparent to those skilled in the art, the values of the resistors and capacitors utilized in oscillator 200 may be varied from those disclosed above to provide for different oscillator output frequencies. As discussed above, however, oscillator 200 is preferably constructed so as to output a square wave having a frequency of 50 kHz or greater, and more preferably, of 800 kHz or greater. Col. 14:22-28.</p> <p>The `183 Patent disclosed “The combination of oscillator voltage, frequency and transistor gain bandwidth product that is used will necessarily vary with the cost, safety and reliability requirements of a given application.” Col. 14:65 – Col. 15:1.</p>

D. New Claim 41

`183 Patent Claim Language	`183 Patent Support

`183 Patent Claim Language	`183 Patent Support
<p>41. The capacitive responsive electronic switching circuit as defined in claim 18, wherein each signal output frequency selectively provided to each row of the plurality of small sized input touch terminals of the keypad is selected from a plurality of Hertz values.</p>	<p>See Figure 11.</p> <p>The `183 Patent discloses “The touch detection circuit of the present invention features operation at frequencies at or above 50 kHz and preferably at or above 800 kHz to minimize the effects of surface contamination from materials such a [sic] skin oils and water. Col. 5:49-53.</p> <p>The `183 Patent discloses “Conversely, at 100 kHz, the glass impedance drops to approximately 1 MΩ resulting in the impedance of the path to ground for pad 59 being twice that of the touched pad 57. For cases where background noise and temperature drifts are comparatively small, a 100 kHz oscillator frequency would allow a sufficiently low detection threshold to be set to differentiate between the signal changes induced at both pads by a human touch opposite a single pad. At 800 kHz, the impedance of the glass drops to 200 kΩ or lower giving a ratio of a greater than 5 to 1 impedance difference between the paths to ground of the touched pad 57 and adjacent pads 59. In fact, the impedance ratio may exceed 10 to 1, as illustrated in the calculation below. This allows the detection threshold for the touched pad to be set well below that of an adjacent pad resulting in a much lower incidence of inadvertent actuation of adjacent touch pads to that of the touched pad. Ideally, the frequency of operation would be kept at the 800 kHz of the preferred embodiment or even higher. However, as noted earlier, higher frequency operation forces the use of more expensive components and designs. For applications where thermal drift and electronic noise levels are low, operation at or near 100 kHz may be possible. However, at 10 kHz and below, the impedance of the glass becomes much greater than that of likely water bridges between pads resulting in adjacent pads being effected as much by a touch as the touched pad itself. Although the preferred frequency is at or above 100 kHz, and more preferably at or</p>

`183 Patent Claim Language	`183 Patent Support
	<p>above 800 kHz, it is conceivable that frequencies as low as 50 kHz could be used provided the frequency creates a difference in the impedance paths of adjacent pads that is sufficient enough to accurately distinguish between an intended touch and the touch of an adjacent pad. Use of frequencies as low as 50 kHz may also be possible depending upon the type of glass or covering or the thickness thereof used for the touch pad. Col. 10:60 – Col. 11:27.</p> <p>The `183 Patent discloses “As will be apparent to those skilled in the art, the values of the resistors and capacitors utilized in oscillator 200 may be varied from those disclosed above to provide for different oscillator output frequencies. As discussed above, however, oscillator 200 is preferably constructed so as to output a square wave having a frequency of 50 kHz or greater, and more preferably, of 800 kHz or greater. Col. 14:22-28.</p> <p>The `183 Patent disclosed “The combination of oscillator voltage, frequency and transistor gain bandwidth product that is used will necessarily vary with the cost, safety and reliability requirements of a given application.” Col. 14:65 – Col. 15:1.</p>

E. New Claim 42

`183 Patent Claim Language	`183 Patent Support
<p>42. The capacitive responsive electronic switching circuit as defined in claim 41, wherein the plurality of Hertz values comprises Hertz values greater than 50 kHz.</p>	<p>See Figure 11.</p> <p>The `183 Patent discloses “The touch detection circuit of the present invention features operation at frequencies at or above 50 kHz and preferably at or above 800 kHz to minimize the effects of surface contamination from materials such a [sic] skin oils and water. Col. 5:49-53.</p> <p>The `183 Patent discloses “Conversely, at 100 kHz, the glass impedance drops to approximately 1 MΩ resulting in the impedance</p>

`183 Patent Claim Language	`183 Patent Support
	<p>of the path to ground for pad 59 being twice that of the touched pad 57. For cases where background noise and temperature drifts are comparatively small, a 100 kHz oscillator frequency would allow a sufficiently low detection threshold to be set to differentiate between the signal changes induced at both pads by a human touch opposite a single pad. At 800 kHz, the impedance of the glass drops to 200 kΩ or lower giving a ratio of a greater than 5 to 1 impedance difference between the paths to ground of the touched pad 57 and adjacent pads 59. In fact, the impedance ratio may exceed 10 to 1, as illustrated in the calculation below. This allows the detection threshold for the touched pad to be set well below that of an adjacent pad resulting in a much lower incidence of inadvertent actuation of adjacent touch pads to that of the touched pad. Ideally, the frequency of operation would be kept at the 800 kHz of the preferred embodiment or even higher. However, as noted earlier, higher frequency operation forces the use of more expensive components and designs. For applications where thermal drift and electronic noise levels are low, operation at or near 100 kHz may be possible. However, at 10 kHz and below, the impedance of the glass becomes much greater than that of likely water bridges between pads resulting in adjacent pads being effected as much by a touch as the touched pad itself. Although the preferred frequency is at or above 100 kHz, and more preferably at or above 800 kHz, it is conceivable that frequencies as low as 50 kHz could be used provided the frequency creates a difference in the impedance paths of adjacent pads that is sufficient enough to accurately distinguish between an intended touch and the touch of an adjacent pad. Use of frequencies as low as 50 kHz may also be possible depending upon the type of glass or covering or the thickness thereof used for the touch pad. Col. 10:60 – Col. 11:27.</p> <p>The `183 Patent discloses “As will be apparent</p>

`183 Patent Claim Language	`183 Patent Support
	<p>to those skilled in the art, the values of the resistors and capacitors utilized in oscillator 200 may be varied from those disclosed above to provide for different oscillator output frequencies. As discussed above, however, oscillator 200 is preferably constructed so as to output a square wave having a frequency of 50 kHz or greater, and more preferably, of 800 kHz or greater. Col. 14:22-28.</p> <p>The `183 Patent disclosed “The combination of oscillator voltage, frequency and transistor gain bandwidth product that is used will necessarily vary with the cost, safety and reliability requirements of a given application.” Col. 14:65 – Col. 15:1.</p>

F. New Claim 43

`183 Patent Claim Language	`183 Patent Support
<p>43. The capacitive responsive electronic switching circuit as defined in claim 41, wherein the plurality of Hertz values comprises Hertz values greater than 100 kHz.</p>	<p>See Figure 11.</p> <p>The `183 Patent discloses “The touch detection circuit of the present invention features operation at frequencies at or above 50 kHz and preferably at or above 800 kHz to minimize the effects of surface contamination from materials such a [sic] skin oils and water. Col. 5:49-53.</p> <p>The `183 Patent discloses “Conversely, at 100 kHz, the glass impedance drops to approximately 1 MΩ resulting in the impedance of the path to ground for pad 59 being twice that of the touched pad 57. For cases where background noise and temperature drifts are comparatively small, a 100 kHz oscillator frequency would allow a sufficiently low detection threshold to be set to differentiate between the signal changes induced at both pads by a human touch opposite a single pad. At 800 kHz, the impedance of the glass drops to 200 kΩ or lower giving a ratio of a greater than 5 to 1 impedance difference between the paths to ground of the touched pad 57 and adjacent pads</p>

`183 Patent Claim Language	`183 Patent Support
	<p>59. In fact, the impedance ratio may exceed 10 to 1, as illustrated in the calculation below. This allows the detection threshold for the touched pad to be set well below that of an adjacent pad resulting in a much lower incidence of inadvertent actuation of adjacent touch pads to that of the touched pad. Ideally, the frequency of operation would be kept at the 800 kHz of the preferred embodiment or even higher. However, as noted earlier, higher frequency operation forces the use of more expensive components and designs. For applications where thermal drift and electronic noise levels are low, operation at or near 100 kHz may be possible. However, at 10 kHz and below, the impedance of the glass becomes much greater than that of likely water bridges between pads resulting in adjacent pads being effected as much by a touch as the touched pad itself. Although the preferred frequency is at or above 100 kHz, and more preferably at or above 800 kHz, it is conceivable that frequencies as low as 50 kHz could be used provided the frequency creates a difference in the impedance paths of adjacent pads that is sufficient enough to accurately distinguish between an intended touch and the touch of an adjacent pad. Use of frequencies as low as 50 kHz may also be possible depending upon the type of glass or covering or the thickness thereof used for the touch pad. Col. 10:60 – Col. 11:27.</p> <p>The `183 Patent discloses “As will be apparent to those skilled in the art, the values of the resistors and capacitors utilized in oscillator 200 may be varied from those disclosed above to provide for different oscillator output frequencies. As discussed above, however, oscillator 200 is preferably constructed so as to output a square wave having a frequency of 50 kHz or greater, and more preferably, of 800 kHz or greater. Col. 14:22-28.</p> <p>The `183 Patent disclosed “The combination of oscillator voltage, frequency and transistor gain</p>

`183 Patent Claim Language	`183 Patent Support
	bandwidth product that is used will necessarily vary with the cost, safety and reliability requirements of a given application.” Col. 14:65 – Col. 15:1.

G. New Claim 44

`183 Patent Claim Language	`183 Patent Support
<p>44. The capacitive responsive electronic switching circuit as defined in claim 41, wherein the plurality of Hertz values comprises Hertz values greater than 800 kHz.</p>	<p>See Fig. 11.</p> <p>The `183 Patent discloses “The touch detection circuit of the present invention features operation at frequencies at or above 50 kHz and preferably at or above 800 kHz to minimize the effects of surface contamination from materials such a [sic] skin oils and water. Col. 5:49-53.</p> <p>The `183 Patent discloses “At 800 kHz, the impedance of the glass drops to 200 kΩ or lower giving a ratio of a greater than 5 to 1 impedance difference between the paths to ground of the touched pad 57 and adjacent pads 59. In fact, the impedance ratio may exceed 10 to 1, as illustrated in the calculation below. This allows the detection threshold for the touched pad to be set well below that of an adjacent pad resulting in a much lower incidence of inadvertent actuation of adjacent touch pads to that of the touched pad. Ideally, the frequency of operation would be kept at the 800 kHz of the preferred embodiment or even higher. However, as noted earlier, higher frequency operation forces the use of more expensive components and designs. For applications where thermal drift and electronic noise levels are low, operation at or near 100 kHz may be possible. However, at 10 kHz and below, the impedance of the glass becomes much greater than that of likely water bridges between pads resulting in adjacent pads being effected as much by a touch as the touched pad itself. Although the preferred frequency is at or above 100 kHz, and more preferably at or above 800 kHz, it is conceivable that frequencies as low as 50 kHz could be used provided the</p>

`183 Patent Claim Language	`183 Patent Support
	<p>frequency creates a difference in the impedance paths of adjacent pads that is sufficient enough to accurately distinguish between an intended touch and the touch of an adjacent pad. Use of frequencies as low as 50 kHz may also be possible depending upon the type of glass or covering or the thickness thereof used for the touch pad. Col. 11:1-27.</p> <p>The `183 Patent discloses “As will be apparent to those skilled in the art, the values of the resistors and capacitors utilized in oscillator 200 may be varied from those disclosed above to provide for different oscillator output frequencies. As discussed above, however, oscillator 200 is preferably constructed so as to output a square wave having a frequency of 50 kHz or greater, and more preferably, of 800 kHz or greater. Col. 14:22-28.</p> <p>The `183 Patent disclosed “The combination of oscillator voltage, frequency and transistor gain bandwidth product that is used will necessarily vary with the cost, safety and reliability requirements of a given application.” Col. 14:65 – Col. 15:1.</p>

H. New Claim 45

For ease of analysis, new independent claim 45 is shown below with pseudo-amendments illustrating the differences between new claim 45 and claim 18 of the `183 Patent following the first reexamination proceeding.

`183 Patent Claim Language	`183 Patent Support
45. A capacitive responsive electronic switching circuit comprising:	See Claim 18.
an oscillator providing a periodic output signal having a predefined frequency;	See Claim 18.
a microcontroller using the	See Figures 4, 11; and Claims 8, 12, 16.

`183 Patent Claim Language	`183 Patent Support
<p>periodic output signal from the oscillator, the microcontroller selectively providing signal output frequencies <u>directly</u> to a plurality of small sized input touch terminals of a keypad;</p>	<p>The `183 Patent discloses “The touch detection circuit of the present invention features operation at frequencies at or above 50kHz and preferably at or above 800 kHz to minimize the effects of surface contamination from materials such a [sic] skin oils and water. It also offers improvements in detection sensitivity that allow close control of the degree of proximity (ideally very close proximity) that is required for actuation and to enable employment of a multiplicity of small sized touch terminals in a physically close array such as a keyboard.” Col. 5:49-57.</p> <p>The `183 Patent discloses “In a first preferred embodiment the circuit offers enhanced detection sensitivity to allow reliable operation with small (finger size) touch pads.” Col. 6:1-3.</p> <p>The `183 Patent discloses “Although the preferred frequency is at or above 100 kHz, and more preferably at or above 800 kHz, it is conceivable that frequencies as low as 50 kHz could be used provided the frequency creates a difference in the impedance paths of adjacent pads that is sufficient enough to accurately distinguish between an intended touch and the touch of an adjacent pad. Use of frequencies as low as 50 kHz may also be possible depending upon the type of glass or covering or the thickness thereof used for the touch pad.” Col. 11:19-27.</p> <p>The `183 Patent discloses “Upon being powered by voltage regulator 100, oscillator 200 generates a square wave with a frequency of 50 kHz, and preferably greater than 800 kHz, and having an amplitude of 26 V peak. The square wave generated by oscillator 200 is supplied via line 201 to a floating common generator 300, a touch pad shield plate 460, a touch circuit 400, and a microcontroller 500. Oscillator 200 is described below with reference to FIG. 6.</p>

`183 Patent Claim Language	`183 Patent Support
	<p>Floating common generator 300 receives the 26 V peak square wave from oscillator 200 and outputs a regulated floating common that is 5 volts below the square wave output from oscillator 200 and has the same phase and frequency as the received square wave. This floating common output is supplied to touch circuit 400 and microcontroller 500 via line 301 such that the output square wave from oscillator 200 and floating common output from floating common generator 300 provide power to touch circuit 400 and microcontroller 500. Details of floating common generator 300 are discussed below with reference to FIG. 7.</p> <p>Touch circuit 400 senses capacitance from a touch pad 450 via line 451 and outputs a signal to microcontroller 500 via line 401 upon detecting a capacitance to ground at touch pad 450 that exceeds a threshold value. The details of touch circuit 400 are described below with reference to FIG. 8.</p> <p>Upon receiving an indication from touch circuit 400 that a sufficient capacitance to ground (typically at least 20 pF) is present at touch pad 450, microcontroller 500 outputs a signal to a load-controlling microcontroller 600 via line 501, which is preferably a two way optical coupling bus.” Col. 12:6-33.</p> <p>The `183 Patent discloses “As will be apparent to those skilled in the art, the values of the resistors and capacitors utilized in oscillator 200 may be varied from those disclosed above to provide for different oscillator output frequencies.” Col. 14:22-25.</p> <p>The `183 Patent discloses “A multiple touch pad circuit constructed in accordance with the second embodiment is shown in FIG. 11. In the second embodiment of FIG. 11, components similar to those in the first embodiment in FIG. 4 are designated with the same references numerals and will not be discussed in detail. The multiple touch pad circuit is a variation of</p>

`183 Patent Claim Language	`183 Patent Support
	<p>the first embodiment in that it includes an array of touch circuits designated as 900₁ through 900_{nm}, which, as shown, include both the touch circuit 400 shown in FIGS. 4 and 8 and the input touch terminal pad 451 (FIG. 4). Microcontroller 500 selects each row of the touch circuits 900₁ to 900_{nm} by providing the signal from oscillator 200 to selected rows of touch circuits. In this manner, microcontroller 500 can sequentially activate the touch circuit rows and associate the received inputs from the columns of the array with the activated touch circuit(s). To keep the path length 451 between the touch pad 450 and the base to the detection transistor 410 to a minimum, the detection circuits 900 are physically located directly beneath the touch pads. To simplify assembly, a flexible circuit board such as vended by Sheldahl, Inc. or Circuit Etching Technics, Inc. can be used for this purpose. Ideally, the printed circuit will be fixed directly against the surface (typically glass) bearing the conductive touch pads to eliminate air gaps and the need for conductive foam pads and spring contacts which were used to fill air gaps.” Col. 18:34-59.</p>
<p>the plurality of small sized input touch terminals defining adjacent areas on a dielectric substrate for an operator to provide inputs by proximity and touch; and</p>	<p>See Claim 18.</p>
<p>a detector circuit coupled to said oscillator for receiving said periodic output signal from said oscillator, and coupled to said input touch terminals, said detector circuit being responsive to signals from said oscillator via said microcontroller and a presence of an operator's body capacitance to ground coupled to said touch terminals when proximal or touched by the operator to provide a control output signal,</p>	<p>See Claim 18.</p>
<p>wherein said predefined frequency of said oscillator and said signal output</p>	<p>See Claim 18.</p>

`183 Patent Claim Language	`183 Patent Support
frequencies are selected to decrease a first impedance of said dielectric substrate relative to a second impedance of any contaminate that may create an electrical path on said dielectric substrate between said adjacent areas defined by the plurality of small sized input touch terminals, and wherein said detector circuit compares a sensed body capacitance change to ground proximate an input touch terminal to a threshold level to prevent inadvertent generation of the control output signal.	

I. New Claim 46

For ease of analysis, new dependent claim 46 is shown below with pseudo-amendments illustrating the differences between new claim 46 and claim 33 of the `183 Patent following the first reexamination proceeding.

`183 Patent Claim Language	`183 Patent Support
46. The capacitive responsive electronic switching circuit as defined in claim 45, further comprising wherein said detector circuit compares the sensed body capacitance change <u>to ground proximate the input touch terminal</u> is caused by the <u>operator's</u> body capacitance decreasing an input touch terminal signal on the detector circuit, and wherein the sensed body <u>capacitance change</u> to ground when proximate to the input touch terminal is compared to a second threshold level to generate the control output signal.	See Claims 1, 18, 28, and 33. The `183 Patent discloses “The touch detection circuit of the present invention features operation at frequencies at or above 50 kHz and preferably at or above 800 kHz to minimize the effects of surface contamination from materials such a [sic] skin oils and water. It also offers improvements in detection sensitivity that allow close control of the degree of proximity (ideally very close proximity) that is required for actuation and to enable employment of a multiplicity of small sized touch terminals in a physically close array such as a keyboard.” Col. 5:49-57. The `183 Patent discloses “Touch circuit 400 senses capacitance from a touch pad 450 via line 451 and outputs a signal to microcontroller 500 via line 401 upon detecting a capacitance to ground at touch pad 450 that exceeds a threshold

`183 Patent Claim Language	`183 Patent Support
	<p>value. The details of touch circuit 400 are described below with reference to FIG. 8.” Col. 12:24-28.</p> <p>The `183 Patent discloses “As can be seen, at 1 kHz, the capacitive impedance of the glass is much greater than the nominal 1 MΩ of the water bridge across the pads. As a result, at 1 kHz, there would be little difference in the impedance paths to ground of the two adjacent pads when either is touched. This would result in the voltage on both pads being pulled towards ground by comparable amounts. Conversely, at 100 kHz, the glass impedance drops to approximately 1 MΩ resulting in the impedance of the path to ground for pad 59 being twice that of the touched pad 57. For cases where background noise and temperature drifts are comparatively small, a 100 kHz oscillator frequency would allow a sufficiently low detection threshold to be set to differentiate between the signal changes induced at both pads by a human touch opposite a single pad. At 800 kHz, the impedance of the glass drops to 200 kΩ or lower giving a ratio of a greater than 5 to 1 impedance difference between the paths to ground of the touched pad 57 and adjacent pads 59. In fact, the impedance ratio may exceed 10 to 1, as illustrated in the calculation below. This allows the detection threshold for the touched pad to be set well below that of an adjacent pad resulting in a much lower incidence of inadvertent actuation of adjacent touch pads to that of the touched pad. Col. 10:54 – Col. 11:9.</p> <p>The `183 Patent discloses “As stated above, the operator’s body includes a capacitance to ground, which may range in a typical person from between 20 to 300 pF. The base terminal of transistor 410 is coupled to it’s [sic] emitter by resistor 412 such that unless capacitance is present by the user touching the touch pad 450, transistor 410 will not be forward biased and will not conduct. Thus, when touch pad 450 is not</p>

`183 Patent Claim Language	`183 Patent Support
	<p>touched, the output signal at the collector terminal of transistor 410 and across pulse stretcher circuit 417 will be zero volts. When, however, a person touches the touch pad 450, that person's body capacitance to ground couples the base of transistor 410 to ground 103 through resistor 413, thereby forward biasing transistor 410 into conduction. This charges capacitor 418 providing a positive DC voltage with respect to the line 301 and causes the output of the Schmitt trigger 420 to go low. Diode 414 is coupled across the base to emitter junction of transistor 410 to clamp the base emitter reverse bias voltage to -0.7V and also reduce the forward recovery and turn-on time. Col. 15:29-47.</p>

J. New Claim 47

For ease of analysis, new dependent claim 47 is shown below with pseudo-amendments illustrating the differences between new claim 47 and claim 34 of the `183 Patent following the first reexamination proceeding.

`183 Patent Claim Language	`183 Patent Support
<p>47. The capacitive responsive electronic switching circuit as defined in claim 45, further comprising wherein said detector circuit compares the sensed body capacitance change <u>to ground proximate the input touch terminal</u> is caused by the operator's body capacitance decreasing an input touch terminal signal amplitude on the detector <u>circuit, and wherein the sensed body capacitance change</u> to ground when proximate to the input touch terminal is compared to a second threshold level to generate the control output signal.</p>	<p>See Claims 1, 18, 28, and 34.</p> <p>The `183 Patent discloses "Another method for implementing capacitive touch switches relies on the change in capacitive coupling between a touch terminal and ground. Systems utilizing such a method are described in U.S. Pat. No. 4,758,735 and U.S. Pat. No. 5,087,825. With this methodology the detection circuit consists of an oscillator (or AC line voltage derivative) providing a signal to a touch terminal whose voltage is then monitored by a detector. The touch terminal is driven in electrical series with other components that function in part as a charge pump. The touch of an operator then provides a capacitive short to ground via the operator's own body capacitance that lowers the amplitude of oscillator voltage seen at the touch terminal." Col. 3:44-56.</p>

`183 Patent Claim Language	`183 Patent Support
	<p>The `183 Patent discloses “The touch detection circuit of the present invention features operation at frequencies at or above 50 kHz and preferably at or above 800 kHz to minimize the effects of surface contamination from materials such a [sic] skin oils and water. It also offers improvements in detection sensitivity that allow close control of the degree of proximity (ideally very close proximity) that is required for actuation and to enable employment of a multiplicity of small sized touch terminals in a physically close array such as a keyboard.” Col. 5:49-57.</p> <p>The `183 Patent discloses “Touch circuit 400 senses capacitance from a touch pad 450 via line 451 and outputs a signal to microcontroller 500 via line 401 upon detecting a capacitance to ground at touch pad 450 that exceeds a threshold value. The details of touch circuit 400 are described below with reference to FIG. 8.” Col. 12:24-28.</p> <p>The `183 Patent discloses “As can be seen, at 1 kHz, the capacitive impedance of the glass is much greater than the nominal 1 MΩ of the water bridge across the pads. As a result, at 1 kHz, there would be little difference in the impedance paths to ground of the two adjacent pads when either is touched. This would result in the voltage on both pads being pulled towards ground by comparable amounts. Conversely, at 100 kHz, the glass impedance drops to approximately 1 MΩ resulting in the impedance of the path to ground for pad 59 being twice that of the touched pad 57. For cases where background noise and temperature drifts are comparatively small, a 100 kHz oscillator frequency would allow a sufficiently low detection threshold to be set to differentiate between the signal changes induced at both pads by a human touch opposite a single pad. At 800 kHz, the impedance of the glass drops to 200 kΩ</p>

`183 Patent Claim Language	`183 Patent Support
	<p>or lower giving a ratio of a greater than 5 to 1 impedance difference between the paths to ground of the touched pad 57 and adjacent pads 59. In fact, the impedance ratio may exceed 10 to 1, as illustrated in the calculation below. This allows the detection threshold for the touched pad to be set well below that of an adjacent pad resulting in a much lower incidence of inadvertent actuation of adjacent touch pads to that of the touched pad. Col. 10:54 – Col. 11:9.</p> <p>The `183 Patent discloses “As stated above, the operator’s body includes a capacitance to ground, which may range in a typical person from between 20 to 300 pF. The base terminal of transistor 410 is coupled to it’s [sic] emitter by resistor 412 such that unless capacitance is present by the user touching the touch pad 450, transistor 410 will not be forward biased and will not conduct. Thus, when touch pad 450 is not touched, the output signal at the collector terminal of transistor 410 and across pulse stretcher circuit 417 will be zero volts. When, however, a person touches the touch pad 450, that person’s body capacitance to ground couples the base of transistor 410 to ground 103 through resistor 413, thereby forward biasing transistor 410 into conduction. This charges capacitor 418 providing a positive DC voltage with respect to the line 301 and causes the output of the Schmitt trigger 420 to go low. Diode 414 is coupled across the base to emitter junction of transistor 410 to clamp the base emitter reverse bias voltage to –0.7V and also reduce the forward recovery and turn-on time. Col. 15:29-47.</p>

K. New Claim 48

`183 Patent Claim Language	`183 Patent Support
<p>48. The capacitive responsive electronic switching circuit as defined in claim 45, wherein the signal output</p>	<p>See Figure 11.</p> <p>The `183 Patent discloses “The touch detection circuit of the present invention features operation at frequencies at or above 50 kHz and preferably</p>

`183 Patent Claim Language	`183 Patent Support
<p>frequencies have a same Hertz value.</p>	<p>at or above 800 kHz to minimize the effects of surface contamination from materials such a [sic] skin oils and water. Col. 5:49-53.</p> <p>The `183 Patent discloses “Conversely, at 100 kHz, the glass impedance drops to approximately 1 MΩ resulting in the impedance of the path to ground for pad 59 being twice that of the touched pad 57. For cases where background noise and temperature drifts are comparatively small, a 100 kHz oscillator frequency would allow a sufficiently low detection threshold to be set to differentiate between the signal changes induced at both pads by a human touch opposite a single pad. At 800 kHz, the impedance of the glass drops to 200 kΩ or lower giving a ratio of a greater than 5 to 1 impedance difference between the paths to ground of the touched pad 57 and adjacent pads 59. In fact, the impedance ratio may exceed 10 to 1, as illustrated in the calculation below. This allows the detection threshold for the touched pad to be set well below that of an adjacent pad resulting in a much lower incidence of inadvertent actuation of adjacent touch pads to that of the touched pad. Ideally, the frequency of operation would be kept at the 800 kHz of the preferred embodiment or even higher. However, as noted earlier, higher frequency operation forces the use of more expensive components and designs. For applications where thermal drift and electronic noise levels are low, operation at or near 100 kHz may be possible. However, at 10 kHz and below, the impedance of the glass becomes much greater than that of likely water bridges between pads resulting in adjacent pads being effected as much by a touch as the touched pad itself. Although the preferred frequency is at or above 100 kHz, and more preferably at or above 800 kHz, it is conceivable that frequencies as low as 50 kHz could be used provided the frequency creates a difference in the impedance paths of adjacent pads that is sufficient enough to accurately distinguish between an intended</p>

`183 Patent Claim Language	`183 Patent Support
	<p>touch and the touch of an adjacent pad. Use of frequencies as low as 50 kHz may also be possible depending upon the type of glass or covering or the thickness thereof used for the touch pad. Col. 10:60 – Col. 11:27.</p> <p>The `183 Patent discloses “As will be apparent to those skilled in the art, the values of the resistors and capacitors utilized in oscillator 200 may be varied from those disclosed above to provide for different oscillator output frequencies. As discussed above, however, oscillator 200 is preferably constructed so as to output a square wave having a frequency of 50 kHz or greater, and more preferably, of 800 kHz or greater. Col. 14:22-28.</p> <p>The `183 Patent disclosed “The combination of oscillator voltage, frequency and transistor gain bandwidth product that is used will necessarily vary with the cost, safety and reliability requirements of a given application.” Col. 14:65 – Col. 15:1.</p>

L. New Claim 49

`183 Patent Claim Language	`183 Patent Support
<p>49. The capacitive responsive electronic switching circuit as defined in claim 45, wherein each signal output frequency is selected from a plurality of Hertz values.</p>	<p>See Figure 11.</p> <p>The `183 Patent discloses “The touch detection circuit of the present invention features operation at frequencies at or above 50 kHz and preferably at or above 800 kHz to minimize the effects of surface contamination from materials such a [sic] skin oils and water. Col. 5:49-53.</p> <p>The `183 Patent discloses “Conversely, at 100 kHz, the glass impedance drops to approximately 1 MΩ resulting in the impedance of the path to ground for pad 59 being twice that of the touched pad 57. For cases where background noise and temperature drifts are comparatively small, a 100 kHz oscillator frequency would allow a sufficiently low</p>

`183 Patent Claim Language	`183 Patent Support
	<p>detection threshold to be set to differentiate between the signal changes induced at both pads by a human touch opposite a single pad. At 800 kHz, the impedance of the glass drops to 200 kΩ or lower giving a ratio of a greater than 5 to 1 impedance difference between the paths to ground of the touched pad 57 and adjacent pads 59. In fact, the impedance ratio may exceed 10 to 1, as illustrated in the calculation below. This allows the detection threshold for the touched pad to be set well below that of an adjacent pad resulting in a much lower incidence of inadvertent actuation of adjacent touch pads to that of the touched pad. Ideally, the frequency of operation would be kept at the 800 kHz of the preferred embodiment or even higher. However, as noted earlier, higher frequency operation forces the use of more expensive components and designs. For applications where thermal drift and electronic noise levels are low, operation at or near 100 kHz may be possible. However, at 10 kHz and below, the impedance of the glass becomes much greater than that of likely water bridges between pads resulting in adjacent pads being effected as much by a touch as the touched pad itself. Although the preferred frequency is at or above 100 kHz, and more preferably at or above 800 kHz, it is conceivable that frequencies as low as 50 kHz could be used provided the frequency creates a difference in the impedance paths of adjacent pads that is sufficient enough to accurately distinguish between an intended touch and the touch of an adjacent pad. Use of frequencies as low as 50 kHz may also be possible depending upon the type of glass or covering or the thickness thereof used for the touch pad. Col. 10:60 – Col. 11:27.</p> <p>The `183 Patent discloses “As will be apparent to those skilled in the art, the values of the resistors and capacitors utilized in oscillator 200 may be varied from those disclosed above to provide for different oscillator output frequencies. As discussed above, however,</p>

`183 Patent Claim Language	`183 Patent Support
	<p>oscillator 200 is preferably constructed so as to output a square wave having a frequency of 50 kHz or greater, and more preferably, of 800 kHz or greater. Col. 14:22-28.</p> <p>The `183 Patent disclosed “The combination of oscillator voltage, frequency and transistor gain bandwidth product that is used will necessarily vary with the cost, safety and reliability requirements of a given application.” Col. 14:65 – Col. 15:1.</p>

M. New Claim 50

`183 Patent Claim Language	`183 Patent Support
<p>50. The capacitive responsive electronic switching circuit as defined in claim 49, wherein the plurality of Hertz values comprises Hertz values greater than 50 kHz.</p>	<p>See Figure 11.</p> <p>The `183 Patent discloses “The touch detection circuit of the present invention features operation at frequencies at or above 50 kHz and preferably at or above 800 kHz to minimize the effects of surface contamination from materials such a [sic] skin oils and water. Col. 5:49-53.</p> <p>The `183 Patent discloses “Conversely, at 100 kHz, the glass impedance drops to approximately 1 MΩ resulting in the impedance of the path to ground for pad 59 being twice that of the touched pad 57. For cases where background noise and temperature drifts are comparatively small, a 100 kHz oscillator frequency would allow a sufficiently low detection threshold to be set to differentiate between the signal changes induced at both pads by a human touch opposite a single pad. At 800 kHz, the impedance of the glass drops to 200 kΩ or lower giving a ratio of a greater than 5 to 1 impedance difference between the paths to ground of the touched pad 57 and adjacent pads 59. In fact, the impedance ratio may exceed 10 to 1, as illustrated in the calculation below. This allows the detection threshold for the touched pad to be set well below that of an adjacent pad resulting in a much lower incidence of</p>

`183 Patent Claim Language	`183 Patent Support
	<p>inadvertent actuation of adjacent touch pads to that of the touched pad. Ideally, the frequency of operation would be kept at the 800 kHz of the preferred embodiment or even higher. However, as noted earlier, higher frequency operation forces the use of more expensive components and designs. For applications where thermal drift and electronic noise levels are low, operation at or near 100 kHz may be possible. However, at 10 kHz and below, the impedance of the glass becomes much greater than that of likely water bridges between pads resulting in adjacent pads being effected as much by a touch as the touched pad itself. Although the preferred frequency is at or above 100 kHz, and more preferably at or above 800 kHz, it is conceivable that frequencies as low as 50 kHz could be used provided the frequency creates a difference in the impedance paths of adjacent pads that is sufficient enough to accurately distinguish between an intended touch and the touch of an adjacent pad. Use of frequencies as low as 50 kHz may also be possible depending upon the type of glass or covering or the thickness thereof used for the touch pad. Col. 10:60 – Col. 11:27.</p> <p>The `183 Patent discloses “As will be apparent to those skilled in the art, the values of the resistors and capacitors utilized in oscillator 200 may be varied from those disclosed above to provide for different oscillator output frequencies. As discussed above, however, oscillator 200 is preferably constructed so as to output a square wave having a frequency of 50 kHz or greater, and more preferably, of 800 kHz or greater. Col. 14:22-28.</p> <p>The `183 Patent disclosed “The combination of oscillator voltage, frequency and transistor gain bandwidth product that is used will necessarily vary with the cost, safety and reliability requirements of a given application.” Col. 14:65 – Col. 15:1.</p>

N. New Claim 51

`183 Patent Claim Language	`183 Patent Support
<p>51. The capacitive responsive electronic switching circuit as defined in claim 49, wherein the plurality of Hertz values comprises Hertz values greater than 100 kHz.</p>	<p>See Figure 11.</p> <p>The `183 Patent discloses “The touch detection circuit of the present invention features operation at frequencies at or above 50 kHz and preferably at or above 800 kHz to minimize the effects of surface contamination from materials such a [sic] skin oils and water. Col. 5:49-53.</p> <p>The `183 Patent discloses “Conversely, at 100 kHz, the glass impedance drops to approximately 1 MΩ resulting in the impedance of the path to ground for pad 59 being twice that of the touched pad 57. For cases where background noise and temperature drifts are comparatively small, a 100 kHz oscillator frequency would allow a sufficiently low detection threshold to be set to differentiate between the signal changes induced at both pads by a human touch opposite a single pad. At 800 kHz, the impedance of the glass drops to 200 kΩ or lower giving a ratio of a greater than 5 to 1 impedance difference between the paths to ground of the touched pad 57 and adjacent pads 59. In fact, the impedance ratio may exceed 10 to 1, as illustrated in the calculation below. This allows the detection threshold for the touched pad to be set well below that of an adjacent pad resulting in a much lower incidence of inadvertent actuation of adjacent touch pads to that of the touched pad. Ideally, the frequency of operation would be kept at the 800 kHz of the preferred embodiment or even higher. However, as noted earlier, higher frequency operation forces the use of more expensive components and designs. For applications where thermal drift and electronic noise levels are low, operation at or near 100 kHz may be possible. However, at 10 kHz and below, the impedance of the glass becomes much greater than that of likely water bridges between pads resulting in adjacent pads being effected as much by a touch as the touched pad itself. Although the preferred frequency is at</p>

`183 Patent Claim Language	`183 Patent Support
	<p>or above 100 kHz, and more preferably at or above 800 kHz, it is conceivable that frequencies as low as 50 kHz could be used provided the frequency creates a difference in the impedance paths of adjacent pads that is sufficient enough to accurately distinguish between an intended touch and the touch of an adjacent pad. Use of frequencies as low as 50 kHz may also be possible depending upon the type of glass or covering or the thickness thereof used for the touch pad. Col. 10:60 – Col. 11:27.</p> <p>The `183 Patent discloses “As will be apparent to those skilled in the art, the values of the resistors and capacitors utilized in oscillator 200 may be varied from those disclosed above to provide for different oscillator output frequencies. As discussed above, however, oscillator 200 is preferably constructed so as to output a square wave having a frequency of 50 kHz or greater, and more preferably, of 800 kHz or greater. Col. 14:22-28.</p> <p>The `183 Patent disclosed “The combination of oscillator voltage, frequency and transistor gain bandwidth product that is used will necessarily vary with the cost, safety and reliability requirements of a given application.” Col. 14:65 – Col. 15:1.</p>

O. New Claim 52

`183 Patent Claim Language	`183 Patent Support
<p>52. The capacitive responsive electronic switching circuit as defined in claim 49, wherein the plurality of Hertz values comprises Hertz values greater than 800 kHz.</p>	<p>See Fig. 11.</p> <p>The `183 Patent discloses “The touch detection circuit of the present invention features operation at frequencies at or above 50 kHz and preferably at or above 800 kHz to minimize the effects of surface contamination from materials such a [sic] skin oils and water. Col. 5:49-53.</p> <p>The `183 Patent discloses “At 800 kHz, the impedance of the glass drops to 200 kΩ or lower</p>

`183 Patent Claim Language	`183 Patent Support
	<p>giving a ratio of a greater than 5 to 1 impedance difference between the paths to ground of the touched pad 57 and adjacent pads 59. In fact, the impedance ratio may exceed 10 to 1, as illustrated in the calculation below. This allows the detection threshold for the touched pad to be set well below that of an adjacent pad resulting in a much lower incidence of inadvertent actuation of adjacent touch pads to that of the touched pad. Ideally, the frequency of operation would be kept at the 800 kHz of the preferred embodiment or even higher. However, as noted earlier, higher frequency operation forces the use of more expensive components and designs. For applications where thermal drift and electronic noise levels are low, operation at or near 100 kHz may be possible. However, at 10 kHz and below, the impedance of the glass becomes much greater than that of likely water bridges between pads resulting in adjacent pads being effected as much by a touch as the touched pad itself. Although the preferred frequency is at or above 100 kHz, and more preferably at or above 800 kHz, it is conceivable that frequencies as low as 50 kHz could be used provided the frequency creates a difference in the impedance paths of adjacent pads that is sufficient enough to accurately distinguish between an intended touch and the touch of an adjacent pad. Use of frequencies as low as 50 kHz may also be possible depending upon the type of glass or covering or the thickness thereof used for the touch pad. Col. 11:1-27.</p> <p>The `183 Patent discloses “As will be apparent to those skilled in the art, the values of the resistors and capacitors utilized in oscillator 200 may be varied from those disclosed above to provide for different oscillator output frequencies. As discussed above, however, oscillator 200 is preferably constructed so as to output a square wave having a frequency of 50 kHz or greater, and more preferably, of 800 kHz or greater. Col. 14:22-28.</p>

`183 Patent Claim Language	`183 Patent Support
	<p>The `183 Patent disclosed “The combination of oscillator voltage, frequency and transistor gain bandwidth product that is used will necessarily vary with the cost, safety and reliability requirements of a given application.” Col. 14:65 – Col. 15:1.</p>

P. New Claim 53

`183 Patent Claim Language	`183 Patent Support
<p>53. The capacitive responsive electronic switching circuit as defined in claim 45, wherein a peak voltage of the signal output frequencies is greater than a supply voltage.</p>	<p>See Figures 4, 5; Claims 27 and 37.</p> <p>The `183 Patent discloses “Having provided a basis for the use of higher frequencies, the basic construction of the electronic switching circuit constructed in accordance with a first embodiment of the present invention is now described with reference to FIG. 4. The electronic switching circuit includes a voltage regulator 100 including input lines 101 and 102 for receiving a 24 V AC line voltage and a line 103 for grounding the circuit. Voltage regulator 100 converts the received AC voltage to a DC voltage and supplies a regulated 5 V DC power to an oscillator 200 via lines 104 and 105. Voltage regulator also supplies oscillator 200 with 26 V DC power via line 106. The details of voltage regulator 100 are discussed below with reference to FIG. 5.</p> <p>Upon being powered by voltage regulator 100, oscillator 200 generates a square wave with a frequency of 50 kHz, and preferably greater than 800 kHz, and having an amplitude of 26 V peak. The square wave generated by oscillator 200 is supplied via line 201 to a floating common generator 300, a touch pad shield plate 460, a touch circuit 400, and a microcontroller 500. Oscillator 200 is described below with reference to FIG. 6.” Col. 11:60 – Col. 12:13.</p> <p>The `183 Patent discloses “Microcontroller 500 selects each row of the touch circuits 900₁ to 900_{nm} by providing the signal from oscillator</p>

`183 Patent Claim Language	`183 Patent Support
	<p>200 to selected rows of touch circuits. In this manner, microcontroller 500 can sequentially activate the touch circuit rows and associate the received inputs from the columns of the array with the activated touch circuit(s).” Col. 18:43-49.</p> <p>The `183 Patent discloses “A preferred circuit for implementing a voltage regulator 100 is shown in FIG. 5. Voltage regulator 100 preferably includes an AC/DC convertor 110 for generating 29 V to 36 V unregulated DC on line 119. This unregulated DC power is supplied to a 5 V DC regulator 120 and to a 26 V DC regulator 130. AC/DC convertor 110 includes diodes 112, 114, 116, and 118, which rectify the supplied 24 V AC power provided on power lines 101 and 102.” Col. 12:50-57; see also Col. 12:57 – Col. 13:31.</p> <p>The `183 Patent discloses “The oscillator circuitry shown in FIG. 6 is very stable over the temperature range of -40° C. to 105° C. The output of the touch switch circuitry drops at a rate of approximately 40 mV/°C. when temperature falls below 0° C. If application requires operation at low temperatures (-40° C.), the following three methods may be used to increase the output of the switch: increase the oscillator’s regulated supply voltage, increase the resistance of resistor 416, and use a higher gain transistor 410. All of these methods would increase sensitivity at high temperatures.” Col. 16:33-41.</p>

Q. New Claim 54

`183 Patent Claim Language	`183 Patent Support
<p>54. The capacitive responsive electronic switching circuit as defined in claim 53, wherein the supply voltage is a battery supply voltage.</p>	<p>The `183 Patent discloses “It will be apparent to those skilled in the art, that various components of voltage regulator 100 may be added or excluded depending upon the source of power available to power the oscillator 200. For example, if the available power is a 110 V AC</p>

`183 Patent Claim Language	`183 Patent Support
	60 Hz commercial power line, a transformer may be added to convert the 100 V AC power to 24 V AC. Alternatively, if a DC batter is used, the AC/DC convertor among other components may be eliminated.” Col 13:23-31.

R. New Claim 55

`183 Patent Claim Language	`183 Patent Support
55. The capacitive responsive electronic switching circuit as defined in claim 53, wherein the supply voltage is a voltage regulator supply voltage.	<p>Figures 4, 5, 11, and 12.</p> <p>The `183 Patent discloses “The electronic switching circuit includes a voltage regulator 100 including input lines 101 and 102 for receiving a 24 V AC line voltage and a line 103 for grounding the circuit. Voltage regulator 100 converts the received AC voltage to a DC voltage and supplies a regulated 5 V DC power to an oscillator 200 via lines 104 and 105. Voltage regulator also supplies oscillator 200 with 26 V DC power via line 106. The details of voltage regulator 100 are discussed below with reference to FIG. 5.” Col. 11:64 – Col. 12:5; see also Col. 12:50 – Col. 13:31.</p>

S. New Claim 56

For ease of analysis, new independent claim 56 is shown below with pseudo-amendments illustrating the differences between new claim 56 and claim 18 of the `183 Patent following the first reexamination proceeding.

`183 Patent Claim Language	`183 Patent Support
56. A capacitive responsive electronic switching circuit comprising:	See Claim 18.
an oscillator providing a periodic output signal having a predefined frequency;	See Claim 18.
a microcontroller using the periodic output signal from the oscillator, the microcontroller selectively providing	See Figures 4, 5, 11; and Claims 8, 12, 16, 27 and 37.

`183 Patent Claim Language	`183 Patent Support
<p>signal output frequencies, <u>wherein a signal output frequency is selectively provided to each row of</u> a plurality of small sized input touch terminals of a keypad, <u>and wherein a peak voltage of the signal output frequencies is greater than a supply voltage;</u></p>	<p>The `183 Patent discloses “The touch detection circuit of the present invention features operation at frequencies at or above 50kHz and preferably at or above 800 kHz to minimize the effects of surface contamination from materials such a [sic] skin oils and water. It also offers improvements in detection sensitivity that allow close control of the degree of proximity (ideally very close proximity) that is required for actuation and to enable employment of a multiplicity of small sized touch terminals in a physically close array such as a keyboard.” Col. 5:49-57.</p> <p>The `183 Patent discloses “In a first preferred embodiment the circuit offers enhanced detection sensitivity to allow reliable operation with small (finger size) touch pads.” Col. 6:1-3.</p> <p>The `183 Patent discloses “Although the preferred frequency is at or above 100 kHz, and more preferably at or above 800 kHz, it is conceivable that frequencies as low as 50 kHz could be used provided the frequency creates a difference in the impedance paths of adjacent pads that is sufficient enough to accurately distinguish between an intended touch and the touch of an adjacent pad. Use of frequencies as low as 50 kHz may also be possible depending upon the type of glass or covering or the thickness thereof used for the touch pad.” Col. 11:19-27.</p> <p>The `183 Patent discloses “Having provided a basis for the use of higher frequencies, the basic construction of the electronic switching circuit constructed in accordance with a first embodiment of the present invention is now described with reference to FIG. 4. The electronic switching circuit includes a voltage regulator 100 including input lines 101 and 102 for receiving a 24 V AC line voltage and a line 103 for grounding the circuit. Voltage regulator 100 converts the received AC voltage to a DC</p>

`183 Patent Claim Language	`183 Patent Support
	<p>voltage and supplies a regulated 5 V DC power to an oscillator 200 via lines 104 and 105. Voltage regulator also supplies oscillator 200 with 26 V DC power via line 106. The details of voltage regulator 100 are discussed below with reference to FIG. 5.</p> <p>Upon being powered by voltage regulator 100, oscillator 200 generates a square wave with a frequency of 50 kHz, and preferably greater than 800 kHz, and having an amplitude of 26 V peak. The square wave generated by oscillator 200 is supplied via line 201 to a floating common generator 300, a touch pad shield plate 460, a touch circuit 400, and a microcontroller 500. Oscillator 200 is described below with reference to FIG. 6.</p> <p>Floating common generator 300 receives the 26 V peak square wave from oscillator 200 and outputs a regulated floating common that is 5 volts below the square wave output from oscillator 200 and has the same phase and frequency as the received square wave. This floating common output is supplied to touch circuit 400 and microcontroller 500 via line 301 such that the output square wave from oscillator 200 and floating common output from floating common generator 300 provide power to touch circuit 400 and microcontroller 500. Details of floating common generator 300 are discussed below with reference to FIG. 7.</p> <p>Touch circuit 400 senses capacitance from a touch pad 450 via line 451 and outputs a signal to microcontroller 500 via line 401 upon detecting a capacitance to ground at touch pad 450 that exceeds a threshold value. The details of touch circuit 400 are described below with reference to FIG. 8.</p> <p>Upon receiving an indication from touch circuit 400 that a sufficient capacitance to ground (typically at least 20 pF) is present at touch pad 450, microcontroller 500 outputs a signal to a load-controlling microcontroller 600 via line 501, which is preferably a two way optical coupling bus.” Col. 11:60 – 12:33.</p>

`183 Patent Claim Language	`183 Patent Support
	<p>The `183 Patent discloses “A preferred circuit for implementing a voltage regulator 100 is shown in FIG. 5. Voltage regulator 100 preferably includes an AC/DC converter 110 for generating 29 V to 36 V unregulated DC on line 119. This unregulated DC power is supplied to a 5 V DC regulator 120 and to a 26 V DC regulator 130. AC/DC converter 110 includes diodes 112, 114, 116, and 118, which rectify the supplied 24 V AC power provided on power lines 101 and 102.” Col. 12:50-57; see also Col. 12:57 – Col. 13:31.</p> <p>The `183 Patent discloses “As will be apparent to those skilled in the art, the values of the resistors and capacitors utilized in oscillator 200 may be varied from those disclosed above to provide for different oscillator output frequencies.” Col. 14:22-25.</p> <p>The `183 Patent discloses “The oscillator circuitry shown in FIG. 6 is very stable over the temperature range of -40° C. to 105° C. The output of the touch switch circuitry drops at a rate of approximately 40 mV/°C. when temperature falls below 0° C. If application requires operation at low temperatures (-40° C.), the following three methods may be used to increase the output of the switch: increase the oscillator’s regulated supply voltage, increase the resistance of resistor 416, and use a higher gain transistor 410. All of these methods would increase sensitivity at high temperatures.” Col. 16:33-41.</p> <p>The `183 Patent discloses “A multiple touch pad circuit constructed in accordance with the second embodiment is shown in FIG. 11. In the second embodiment of FIG. 11, components similar to those in the first embodiment in FIG. 4 are designated with the same references numerals and will not be discussed in detail. The multiple touch pad circuit is a variation of</p>

`183 Patent Claim Language	`183 Patent Support
	<p>the first embodiment in that it includes an array of touch circuits designated as 900₁ through 900_{nm}, which, as shown, include both the touch circuit 400 shown in FIGS. 4 and 8 and the input touch terminal pad 451 (FIG. 4). Microcontroller 500 selects each row of the touch circuits 900₁ to 900_{nm} by providing the signal from oscillator 200 to selected rows of touch circuits. In this manner, microcontroller 500 can sequentially activate the touch circuit rows and associate the received inputs from the columns of the array with the activated touch circuit(s). To keep the path length 451 between the touch pad 450 and the base to the detection transistor 410 to a minimum, the detection circuits 900 are physically located directly beneath the touch pads. To simplify assembly, a flexible circuit board such as vended by Sheldahl, Inc. or Circuit Etching Technics, Inc. can be used for this purpose. Ideally, the printed circuit will be fixed directly against the surface (typically glass) bearing the conductive touch pads to eliminate air gaps and the need for conductive foam pads and spring contacts which were used to fill air gaps.” Col. 18:34-59.</p>
<p>the plurality of small sized input touch terminals defining adjacent areas on a dielectric substrate for an operator to provide inputs by proximity and touch; and</p>	<p>See Claim 18.</p>
<p>a detector circuit coupled to said oscillator for receiving said periodic output signal from said oscillator, and coupled to said input touch terminals, said detector circuit being responsive to signals from said oscillator via said microcontroller and a presence of an operator's body capacitance to ground coupled to said touch terminals when proximal or touched by the operator to provide a control output signal,</p>	<p>See Claim 18.</p>
<p>wherein said predefined frequency of said oscillator and said signal output</p>	<p>See Claim 18.</p>

`183 Patent Claim Language	`183 Patent Support
frequencies are selected to decrease a first impedance of said dielectric substrate relative to a second impedance of any contaminate that may create an electrical path on said dielectric substrate between said adjacent areas defined by the plurality of small sized input touch terminals, and wherein said detector circuit compares a sensed body capacitance change to ground proximate an input touch terminal to a threshold level to prevent inadvertent generation of the control output signal.	

T. New Claim 57

For ease of analysis, new dependent claim 57 is shown below with pseudo-amendments illustrating the differences between new claim 57 and claim 33 of the `183 Patent following the first reexamination proceeding.

`183 Patent Claim Language	`183 Patent Support
57. The capacitive responsive electronic switching circuit as defined in claim 56, further comprising wherein said detector circuit compares the sensed body capacitance change <u>to ground proximate the input touch terminal</u> is caused by the <u>operator's</u> body capacitance decreasing an input touch terminal signal on the detector circuit, and wherein the sensed body <u>capacitance change</u> to ground when proximate to the input touch terminal is <u>compared</u> to a second threshold level to generate the control output signal.	<p>See Claims 1, 18, 28, and 33.</p> <p>The `183 Patent discloses “The touch detection circuit of the present invention features operation at frequencies at or above 50 kHz and preferably at or above 800 kHz to minimize the effects of surface contamination from materials such a [sic] skin oils and water. It also offers improvements in detection sensitivity that allow close control of the degree of proximity (ideally very close proximity) that is required for actuation and to enable employment of a multiplicity of small sized touch terminals in a physically close array such as a keyboard.” Col. 5:49-57.</p> <p>The `183 Patent discloses “Touch circuit 400 senses capacitance from a touch pad 450 via line 451 and outputs a signal to microcontroller 500 via line 401 upon detecting a capacitance to ground at touch pad 450 that exceeds a threshold</p>

`183 Patent Claim Language	`183 Patent Support
	<p>value. The details of touch circuit 400 are described below with reference to FIG. 8.” Col. 12:24-28.</p> <p>The `183 Patent discloses “As can be seen, at 1 kHz, the capacitive impedance of the glass is much greater than the nominal 1 MΩ of the water bridge across the pads. As a result, at 1 kHz, there would be little difference in the impedance paths to ground of the two adjacent pads when either is touched. This would result in the voltage on both pads being pulled towards ground by comparable amounts. Conversely, at 100 kHz, the glass impedance drops to approximately 1 MΩ resulting in the impedance of the path to ground for pad 59 being twice that of the touched pad 57. For cases where background noise and temperature drifts are comparatively small, a 100 kHz oscillator frequency would allow a sufficiently low detection threshold to be set to differentiate between the signal changes induced at both pads by a human touch opposite a single pad. At 800 kHz, the impedance of the glass drops to 200 kΩ or lower giving a ratio of a greater than 5 to 1 impedance difference between the paths to ground of the touched pad 57 and adjacent pads 59. In fact, the impedance ratio may exceed 10 to 1, as illustrated in the calculation below. This allows the detection threshold for the touched pad to be set well below that of an adjacent pad resulting in a much lower incidence of inadvertent actuation of adjacent touch pads to that of the touched pad. Col. 10:54 – Col. 11:9.</p> <p>The `183 Patent discloses “As stated above, the operator’s body includes a capacitance to ground, which may range in a typical person from between 20 to 300 pF. The base terminal of transistor 410 is coupled to it’s [sic] emitter by resistor 412 such that unless capacitance is present by the user touching the touch pad 450, transistor 410 will not be forward biased and will not conduct. Thus, when touch pad 450 is not</p>

`183 Patent Claim Language	`183 Patent Support
	<p>touched, the output signal at the collector terminal of transistor 410 and across pulse stretcher circuit 417 will be zero volts. When, however, a person touches the touch pad 450, that person's body capacitance to ground couples the base of transistor 410 to ground 103 through resistor 413, thereby forward biasing transistor 410 into conduction. This charges capacitor 418 providing a positive DC voltage with respect to the line 301 and causes the output of the Schmitt trigger 420 to go low. Diode 414 is coupled across the base to emitter junction of transistor 410 to clamp the base emitter reverse bias voltage to -0.7V and also reduce the forward recovery and turn-on time. Col. 15:29-47.</p>

U. New Claim 58

For ease of analysis, new dependent claim 58 is shown below with pseudo-amendments illustrating the differences between new claim 58 and claim 34 of the `183 Patent following the first reexamination proceeding.

`183 Patent Claim Language	`183 Patent Support
<p>58. The capacitive responsive electronic switching circuit as defined in claim 56, further comprising wherein said detector circuit compares the sensed body capacitance change <u>to ground proximate the input touch terminal is</u> caused by the operator's body capacitance decreasing an input touch terminal signal amplitude on the detector <u>circuit, and wherein the sensed body capacitance change to ground when proximate to the input touch terminal is compared</u> to a second threshold level to generate the control output signal.</p>	<p>See Claims 1, 18, 28, and 34.</p> <p>The `183 Patent discloses "Another method for implementing capacitive touch switches relies on the change in capacitive coupling between a touch terminal and ground. Systems utilizing such a method are described in U.S. Pat. No. 4,758,735 and U.S. Pat. No. 5,087,825. With this methodology the detection circuit consists of an oscillator (or AC line voltage derivative) providing a signal to a touch terminal whose voltage is then monitored by a detector. The touch terminal is driven in electrical series with other components that function in part as a charge pump. The touch of an operator then provides a capacitive short to ground via the operator's own body capacitance that lowers the amplitude of oscillator voltage seen at the touch terminal." Col. 3:44-56.</p>

`183 Patent Claim Language	`183 Patent Support
	<p>The `183 Patent discloses “The touch detection circuit of the present invention features operation at frequencies at or above 50 kHz and preferably at or above 800 kHz to minimize the effects of surface contamination from materials such a [sic] skin oils and water. It also offers improvements in detection sensitivity that allow close control of the degree of proximity (ideally very close proximity) that is required for actuation and to enable employment of a multiplicity of small sized touch terminals in a physically close array such as a keyboard.” Col. 5:49-57.</p> <p>The `183 Patent discloses “Touch circuit 400 senses capacitance from a touch pad 450 via line 451 and outputs a signal to microcontroller 500 via line 401 upon detecting a capacitance to ground at touch pad 450 that exceeds a threshold value. The details of touch circuit 400 are described below with reference to FIG. 8.” Col. 12:24-28.</p> <p>The `183 Patent discloses “As can be seen, at 1 kHz, the capacitive impedance of the glass is much greater than the nominal 1 MΩ of the water bridge across the pads. As a result, at 1 kHz, there would be little difference in the impedance paths to ground of the two adjacent pads when either is touched. This would result in the voltage on both pads being pulled towards ground by comparable amounts. Conversely, at 100 kHz, the glass impedance drops to approximately 1 MΩ resulting in the impedance of the path to ground for pad 59 being twice that of the touched pad 57. For cases where background noise and temperature drifts are comparatively small, a 100 kHz oscillator frequency would allow a sufficiently low detection threshold to be set to differentiate between the signal changes induced at both pads by a human touch opposite a single pad. At 800 kHz, the impedance of the glass drops to 200 kΩ</p>

`183 Patent Claim Language	`183 Patent Support
	<p>or lower giving a ratio of a greater than 5 to 1 impedance difference between the paths to ground of the touched pad 57 and adjacent pads 59. In fact, the impedance ratio may exceed 10 to 1, as illustrated in the calculation below. This allows the detection threshold for the touched pad to be set well below that of an adjacent pad resulting in a much lower incidence of inadvertent actuation of adjacent touch pads to that of the touched pad. Col. 10:54 – Col. 11:9.</p> <p>The `183 Patent discloses “As stated above, the operator’s body includes a capacitance to ground, which may range in a typical person from between 20 to 300 pF. The base terminal of transistor 410 is coupled to it’s [sic] emitter by resistor 412 such that unless capacitance is present by the user touching the touch pad 450, transistor 410 will not be forward biased and will not conduct. Thus, when touch pad 450 is not touched, the output signal at the collector terminal of transistor 410 and across pulse stretcher circuit 417 will be zero volts. When, however, a person touches the touch pad 450, that person’s body capacitance to ground couples the base of transistor 410 to ground 103 through resistor 413, thereby forward biasing transistor 410 into conduction. This charges capacitor 418 providing a positive DC voltage with respect to the line 301 and causes the output of the Schmitt trigger 420 to go low. Diode 414 is coupled across the base to emitter junction of transistor 410 to clamp the base emitter reverse bias voltage to –0.7V and also reduce the forward recovery and turn-on time. Col. 15:29-47.</p>

V. New Claim 59

`183 Patent Claim Language	`183 Patent Support
<p>59. The capacitive responsive electronic switching circuit as defined in claim 56, wherein each signal output frequency selectively provided to each row of the plurality of small sized input</p>	<p>See Figure 11.</p> <p>The `183 Patent discloses “The touch detection circuit of the present invention features operation at frequencies at or above 50 kHz and preferably</p>

`183 Patent Claim Language	`183 Patent Support
<p>touch terminals of the keypad has a same Hertz value.</p>	<p>at or above 800 kHz to minimize the effects of surface contamination from materials such a [sic] skin oils and water. Col. 5:49-53.</p> <p>The `183 Patent discloses “Conversely, at 100 kHz, the glass impedance drops to approximately 1 MΩ resulting in the impedance of the path to ground for pad 59 being twice that of the touched pad 57. For cases where background noise and temperature drifts are comparatively small, a 100 kHz oscillator frequency would allow a sufficiently low detection threshold to be set to differentiate between the signal changes induced at both pads by a human touch opposite a single pad. At 800 kHz, the impedance of the glass drops to 200 kΩ or lower giving a ratio of a greater than 5 to 1 impedance difference between the paths to ground of the touched pad 57 and adjacent pads 59. In fact, the impedance ratio may exceed 10 to 1, as illustrated in the calculation below. This allows the detection threshold for the touched pad to be set well below that of an adjacent pad resulting in a much lower incidence of inadvertent actuation of adjacent touch pads to that of the touched pad. Ideally, the frequency of operation would be kept at the 800 kHz of the preferred embodiment or even higher. However, as noted earlier, higher frequency operation forces the use of more expensive components and designs. For applications where thermal drift and electronic noise levels are low, operation at or near 100 kHz may be possible. However, at 10 kHz and below, the impedance of the glass becomes much greater than that of likely water bridges between pads resulting in adjacent pads being effected as much by a touch as the touched pad itself. Although the preferred frequency is at or above 100 kHz, and more preferably at or above 800 kHz, it is conceivable that frequencies as low as 50 kHz could be used provided the frequency creates a difference in the impedance paths of adjacent pads that is sufficient enough to accurately distinguish between an intended</p>

`183 Patent Claim Language	`183 Patent Support
	<p>touch and the touch of an adjacent pad. Use of frequencies as low as 50 kHz may also be possible depending upon the type of glass or covering or the thickness thereof used for the touch pad. Col. 10:60 – Col. 11:27.</p> <p>The `183 Patent discloses “As will be apparent to those skilled in the art, the values of the resistors and capacitors utilized in oscillator 200 may be varied from those disclosed above to provide for different oscillator output frequencies. As discussed above, however, oscillator 200 is preferably constructed so as to output a square wave having a frequency of 50 kHz or greater, and more preferably, of 800 kHz or greater. Col. 14:22-28.</p> <p>The `183 Patent disclosed “The combination of oscillator voltage, frequency and transistor gain bandwidth product that is used will necessarily vary with the cost, safety and reliability requirements of a given application.” Col. 14:65 – Col. 15:1.</p>

W. New Claim 60

`183 Patent Claim Language	`183 Patent Support
<p>60. The capacitive responsive electronic switching circuit as defined in claim 56, wherein each signal output frequency selectively provided to each row of the plurality of small sized input touch terminals of the keypad is selected from a plurality of Hertz values.</p>	<p>See Figure 11.</p> <p>The `183 Patent discloses “The touch detection circuit of the present invention features operation at frequencies at or above 50 kHz and preferably at or above 800 kHz to minimize the effects of surface contamination from materials such a [sic] skin oils and water. Col. 5:49-53.</p> <p>The `183 Patent discloses “Conversely, at 100 kHz, the glass impedance drops to approximately 1 MΩ resulting in the impedance of the path to ground for pad 59 being twice that of the touched pad 57. For cases where background noise and temperature drifts are comparatively small, a 100 kHz oscillator frequency would allow a sufficiently low</p>

`183 Patent Claim Language	`183 Patent Support
	<p>detection threshold to be set to differentiate between the signal changes induced at both pads by a human touch opposite a single pad. At 800 kHz, the impedance of the glass drops to 200 kΩ or lower giving a ratio of a greater than 5 to 1 impedance difference between the paths to ground of the touched pad 57 and adjacent pads 59. In fact, the impedance ratio may exceed 10 to 1, as illustrated in the calculation below. This allows the detection threshold for the touched pad to be set well below that of an adjacent pad resulting in a much lower incidence of inadvertent actuation of adjacent touch pads to that of the touched pad. Ideally, the frequency of operation would be kept at the 800 kHz of the preferred embodiment or even higher. However, as noted earlier, higher frequency operation forces the use of more expensive components and designs. For applications where thermal drift and electronic noise levels are low, operation at or near 100 kHz may be possible. However, at 10 kHz and below, the impedance of the glass becomes much greater than that of likely water bridges between pads resulting in adjacent pads being effected as much by a touch as the touched pad itself. Although the preferred frequency is at or above 100 kHz, and more preferably at or above 800 kHz, it is conceivable that frequencies as low as 50 kHz could be used provided the frequency creates a difference in the impedance paths of adjacent pads that is sufficient enough to accurately distinguish between an intended touch and the touch of an adjacent pad. Use of frequencies as low as 50 kHz may also be possible depending upon the type of glass or covering or the thickness thereof used for the touch pad. Col. 10:60 – Col. 11:27.</p> <p>The `183 Patent discloses “As will be apparent to those skilled in the art, the values of the resistors and capacitors utilized in oscillator 200 may be varied from those disclosed above to provide for different oscillator output frequencies. As discussed above, however,</p>

`183 Patent Claim Language	`183 Patent Support
	<p>oscillator 200 is preferably constructed so as to output a square wave having a frequency of 50 kHz or greater, and more preferably, of 800 kHz or greater. Col. 14:22-28.</p> <p>The `183 Patent disclosed “The combination of oscillator voltage, frequency and transistor gain bandwidth product that is used will necessarily vary with the cost, safety and reliability requirements of a given application.” Col. 14:65 – Col. 15:1.</p>

X. New Claim 61

`183 Patent Claim Language	`183 Patent Support
<p>61. The capacitive responsive electronic switching circuit as defined in claim 60, wherein the plurality of Hertz values comprises Hertz values greater than 50 kHz.</p>	<p>See Figure 11.</p> <p>The `183 Patent discloses “The touch detection circuit of the present invention features operation at frequencies at or above 50 kHz and preferably at or above 800 kHz to minimize the effects of surface contamination from materials such a [sic] skin oils and water. Col. 5:49-53.</p> <p>The `183 Patent discloses “Conversely, at 100 kHz, the glass impedance drops to approximately 1 MΩ resulting in the impedance of the path to ground for pad 59 being twice that of the touched pad 57. For cases where background noise and temperature drifts are comparatively small, a 100 kHz oscillator frequency would allow a sufficiently low detection threshold to be set to differentiate between the signal changes induced at both pads by a human touch opposite a single pad. At 800 kHz, the impedance of the glass drops to 200 kΩ or lower giving a ratio of a greater than 5 to 1 impedance difference between the paths to ground of the touched pad 57 and adjacent pads 59. In fact, the impedance ratio may exceed 10 to 1, as illustrated in the calculation below. This allows the detection threshold for the touched pad to be set well below that of an adjacent pad resulting in a much lower incidence of</p>

`183 Patent Claim Language	`183 Patent Support
	<p>inadvertent actuation of adjacent touch pads to that of the touched pad. Ideally, the frequency of operation would be kept at the 800 kHz of the preferred embodiment or even higher. However, as noted earlier, higher frequency operation forces the use of more expensive components and designs. For applications where thermal drift and electronic noise levels are low, operation at or near 100 kHz may be possible. However, at 10 kHz and below, the impedance of the glass becomes much greater than that of likely water bridges between pads resulting in adjacent pads being effected as much by a touch as the touched pad itself. Although the preferred frequency is at or above 100 kHz, and more preferably at or above 800 kHz, it is conceivable that frequencies as low as 50 kHz could be used provided the frequency creates a difference in the impedance paths of adjacent pads that is sufficient enough to accurately distinguish between an intended touch and the touch of an adjacent pad. Use of frequencies as low as 50 kHz may also be possible depending upon the type of glass or covering or the thickness thereof used for the touch pad. Col. 10:60 – Col. 11:27.</p> <p>The `183 Patent discloses “As will be apparent to those skilled in the art, the values of the resistors and capacitors utilized in oscillator 200 may be varied from those disclosed above to provide for different oscillator output frequencies. As discussed above, however, oscillator 200 is preferably constructed so as to output a square wave having a frequency of 50 kHz or greater, and more preferably, of 800 kHz or greater. Col. 14:22-28.</p> <p>The `183 Patent disclosed “The combination of oscillator voltage, frequency and transistor gain bandwidth product that is used will necessarily vary with the cost, safety and reliability requirements of a given application.” Col. 14:65 – Col. 15:1.</p>

Y. New Claim 62

`183 Patent Claim Language	`183 Patent Support
<p>62. The capacitive responsive electronic switching circuit as defined in claim 60, wherein the plurality of Hertz values comprises Hertz values greater than 100 kHz.</p>	<p>See Figure 11.</p> <p>The `183 Patent discloses “The touch detection circuit of the present invention features operation at frequencies at or above 50 kHz and preferably at or above 800 kHz to minimize the effects of surface contamination from materials such a [sic] skin oils and water. Col. 5:49-53.</p> <p>The `183 Patent discloses “Conversely, at 100 kHz, the glass impedance drops to approximately 1 MΩ resulting in the impedance of the path to ground for pad 59 being twice that of the touched pad 57. For cases where background noise and temperature drifts are comparatively small, a 100 kHz oscillator frequency would allow a sufficiently low detection threshold to be set to differentiate between the signal changes induced at both pads by a human touch opposite a single pad. At 800 kHz, the impedance of the glass drops to 200 kΩ or lower giving a ratio of a greater than 5 to 1 impedance difference between the paths to ground of the touched pad 57 and adjacent pads 59. In fact, the impedance ratio may exceed 10 to 1, as illustrated in the calculation below. This allows the detection threshold for the touched pad to be set well below that of an adjacent pad resulting in a much lower incidence of inadvertent actuation of adjacent touch pads to that of the touched pad. Ideally, the frequency of operation would be kept at the 800 kHz of the preferred embodiment or even higher. However, as noted earlier, higher frequency operation forces the use of more expensive components and designs. For applications where thermal drift and electronic noise levels are low, operation at or near 100 kHz may be possible. However, at 10 kHz and below, the impedance of the glass becomes much greater than that of likely water bridges between pads resulting in adjacent pads being effected as much by a touch as the touched pad itself. Although the preferred frequency is at</p>

`183 Patent Claim Language	`183 Patent Support
	<p>or above 100 kHz, and more preferably at or above 800 kHz, it is conceivable that frequencies as low as 50 kHz could be used provided the frequency creates a difference in the impedance paths of adjacent pads that is sufficient enough to accurately distinguish between an intended touch and the touch of an adjacent pad. Use of frequencies as low as 50 kHz may also be possible depending upon the type of glass or covering or the thickness thereof used for the touch pad. Col. 10:60 – Col. 11:27.</p> <p>The `183 Patent discloses “As will be apparent to those skilled in the art, the values of the resistors and capacitors utilized in oscillator 200 may be varied from those disclosed above to provide for different oscillator output frequencies. As discussed above, however, oscillator 200 is preferably constructed so as to output a square wave having a frequency of 50 kHz or greater, and more preferably, of 800 kHz or greater. Col. 14:22-28.</p> <p>The `183 Patent disclosed “The combination of oscillator voltage, frequency and transistor gain bandwidth product that is used will necessarily vary with the cost, safety and reliability requirements of a given application.” Col. 14:65 – Col. 15:1.</p>

Z. New Claim 63

`183 Patent Claim Language	`183 Patent Support
<p>63. The capacitive responsive electronic switching circuit as defined in claim 60, wherein the plurality of Hertz values comprises Hertz values greater than 800 kHz.</p>	<p>See Fig. 11.</p> <p>The `183 Patent discloses “The touch detection circuit of the present invention features operation at frequencies at or above 50 kHz and preferably at or above 800 kHz to minimize the effects of surface contamination from materials such a [sic] skin oils and water. Col. 5:49-53.</p> <p>The `183 Patent discloses “At 800 kHz, the impedance of the glass drops to 200 kΩ or lower</p>

`183 Patent Claim Language	`183 Patent Support
	<p>giving a ratio of a greater than 5 to 1 impedance difference between the paths to ground of the touched pad 57 and adjacent pads 59. In fact, the impedance ratio may exceed 10 to 1, as illustrated in the calculation below. This allows the detection threshold for the touched pad to be set well below that of an adjacent pad resulting in a much lower incidence of inadvertent actuation of adjacent touch pads to that of the touched pad. Ideally, the frequency of operation would be kept at the 800 kHz of the preferred embodiment or even higher. However, as noted earlier, higher frequency operation forces the use of more expensive components and designs. For applications where thermal drift and electronic noise levels are low, operation at or near 100 kHz may be possible. However, at 10 kHz and below, the impedance of the glass becomes much greater than that of likely water bridges between pads resulting in adjacent pads being effected as much by a touch as the touched pad itself. Although the preferred frequency is at or above 100 kHz, and more preferably at or above 800 kHz, it is conceivable that frequencies as low as 50 kHz could be used provided the frequency creates a difference in the impedance paths of adjacent pads that is sufficient enough to accurately distinguish between an intended touch and the touch of an adjacent pad. Use of frequencies as low as 50 kHz may also be possible depending upon the type of glass or covering or the thickness thereof used for the touch pad. Col. 11:1-27.</p> <p>The `183 Patent discloses “As will be apparent to those skilled in the art, the values of the resistors and capacitors utilized in oscillator 200 may be varied from those disclosed above to provide for different oscillator output frequencies. As discussed above, however, oscillator 200 is preferably constructed so as to output a square wave having a frequency of 50 kHz or greater, and more preferably, of 800 kHz or greater. Col. 14:22-28.</p>

`183 Patent Claim Language	`183 Patent Support
	The `183 Patent disclosed “The combination of oscillator voltage, frequency and transistor gain bandwidth product that is used will necessarily vary with the cost, safety and reliability requirements of a given application.” Col. 14:65 – Col. 15:1.

AA. New Claim 64

`183 Patent Claim Language	`183 Patent Support
64. The capacitive responsive electronic switching circuit as defined in claim 56, wherein the supply voltage is a battery supply voltage.	The `183 Patent discloses “It will be apparent to those skilled in the art, that various components of voltage regulator 100 may be added or excluded depending upon the source of power available to power the oscillator 200. For example, if the available power is a 110 V AC 60 Hz commercial power line, a transformer may be added to convert the 100 V AC power to 24 V AC. Alternatively, if a DC batter is used, the AC/DC convertor among other components may be eliminated.” Col 13:23-31.

BB. New Claim 65

`183 Patent Claim Language	`183 Patent Support
65. The capacitive responsive electronic switching circuit as defined in claim 56, wherein the supply voltage is a voltage regulator supply voltage.	Figures 4, 5, 11, and 12. The `183 Patent discloses “The electronic switching circuit includes a voltage regulator 100 including input lines 101 and 102 for receiving a 24 V AC line voltage and a line 103 for grounding the circuit. Voltage regulator 100 converts the received AC voltage to a DC voltage and supplies a regulated 5 V DC power to an oscillator 200 via lines 104 and 105. Voltage regulator also supplies oscillator 200 with 26 V DC power via line 106. The details of voltage regulator 100 are discussed below with reference to FIG. 5.” Col. 11:64 – Col. 12:5; see also Col. 12:50 – Col. 13:31.

CC. New Claim 66

`183 Patent Claim Language	`183 Patent Support
<p>66. The capacitive responsive electronic switching circuit as defined in claim 27, wherein each signal output frequency selectively provided to each row of the closely spaced array of input touch terminals of the keypad has a same Hertz value.</p>	<p>See Figure 11.</p> <p>The `183 Patent discloses “The touch detection circuit of the present invention features operation at frequencies at or above 50 kHz and preferably at or above 800 kHz to minimize the effects of surface contamination from materials such a [sic] skin oils and water. Col. 5:49-53.</p> <p>The `183 Patent discloses “Conversely, at 100 kHz, the glass impedance drops to approximately 1 MΩ resulting in the impedance of the path to ground for pad 59 being twice that of the touched pad 57. For cases where background noise and temperature drifts are comparatively small, a 100 kHz oscillator frequency would allow a sufficiently low detection threshold to be set to differentiate between the signal changes induced at both pads by a human touch opposite a single pad. At 800 kHz, the impedance of the glass drops to 200 kΩ or lower giving a ratio of a greater than 5 to 1 impedance difference between the paths to ground of the touched pad 57 and adjacent pads 59. In fact, the impedance ratio may exceed 10 to 1, as illustrated in the calculation below. This allows the detection threshold for the touched pad to be set well below that of an adjacent pad resulting in a much lower incidence of inadvertent actuation of adjacent touch pads to that of the touched pad. Ideally, the frequency of operation would be kept at the 800 kHz of the preferred embodiment or even higher. However, as noted earlier, higher frequency operation forces the use of more expensive components and designs. For applications where thermal drift and electronic noise levels are low, operation at or near 100 kHz may be possible. However, at 10 kHz and below, the impedance of the glass becomes much greater than that of likely water bridges between pads resulting in adjacent pads being effected as much by a touch as the touched pad itself. Although the preferred frequency is at</p>

`183 Patent Claim Language	`183 Patent Support
	<p>or above 100 kHz, and more preferably at or above 800 kHz, it is conceivable that frequencies as low as 50 kHz could be used provided the frequency creates a difference in the impedance paths of adjacent pads that is sufficient enough to accurately distinguish between an intended touch and the touch of an adjacent pad. Use of frequencies as low as 50 kHz may also be possible depending upon the type of glass or covering or the thickness thereof used for the touch pad. Col. 10:60 – Col. 11:27.</p> <p>The `183 Patent discloses “As will be apparent to those skilled in the art, the values of the resistors and capacitors utilized in oscillator 200 may be varied from those disclosed above to provide for different oscillator output frequencies. As discussed above, however, oscillator 200 is preferably constructed so as to output a square wave having a frequency of 50 kHz or greater, and more preferably, of 800 kHz or greater. Col. 14:22-28.</p> <p>The `183 Patent disclosed “The combination of oscillator voltage, frequency and transistor gain bandwidth product that is used will necessarily vary with the cost, safety and reliability requirements of a given application.” Col. 14:65 – Col. 15:1.</p>

DD. New Claim 67

`183 Patent Claim Language	`183 Patent Support
<p>67. The capacitive responsive electronic switching circuit as defined in claim 27, wherein each signal output frequency selectively provided to each row of the closely spaced array of input touch terminals of the keypad is selected from a plurality of Hertz values.</p>	<p>See Figure 11.</p> <p>The `183 Patent discloses “The touch detection circuit of the present invention features operation at frequencies at or above 50 kHz and preferably at or above 800 kHz to minimize the effects of surface contamination from materials such a [sic] skin oils and water. Col. 5:49-53.</p> <p>The `183 Patent discloses “Conversely, at 100 kHz, the glass impedance drops to</p>

`183 Patent Claim Language	`183 Patent Support
	<p>approximately 1 MΩ resulting in the impedance of the path to ground for pad 59 being twice that of the touched pad 57. For cases where background noise and temperature drifts are comparatively small, a 100 kHz oscillator frequency would allow a sufficiently low detection threshold to be set to differentiate between the signal changes induced at both pads by a human touch opposite a single pad. At 800 kHz, the impedance of the glass drops to 200 kΩ or lower giving a ratio of a greater than 5 to 1 impedance difference between the paths to ground of the touched pad 57 and adjacent pads 59. In fact, the impedance ratio may exceed 10 to 1, as illustrated in the calculation below. This allows the detection threshold for the touched pad to be set well below that of an adjacent pad resulting in a much lower incidence of inadvertent actuation of adjacent touch pads to that of the touched pad. Ideally, the frequency of operation would be kept at the 800 kHz of the preferred embodiment or even higher. However, as noted earlier, higher frequency operation forces the use of more expensive components and designs. For applications where thermal drift and electronic noise levels are low, operation at or near 100 kHz may be possible. However, at 10 kHz and below, the impedance of the glass becomes much greater than that of likely water bridges between pads resulting in adjacent pads being effected as much by a touch as the touched pad itself. Although the preferred frequency is at or above 100 kHz, and more preferably at or above 800 kHz, it is conceivable that frequencies as low as 50 kHz could be used provided the frequency creates a difference in the impedance paths of adjacent pads that is sufficient enough to accurately distinguish between an intended touch and the touch of an adjacent pad. Use of frequencies as low as 50 kHz may also be possible depending upon the type of glass or covering or the thickness thereof used for the touch pad. Col. 10:60 – Col. 11:27.</p>

`183 Patent Claim Language	`183 Patent Support
	<p>The `183 Patent discloses “As will be apparent to those skilled in the art, the values of the resistors and capacitors utilized in oscillator 200 may be varied from those disclosed above to provide for different oscillator output frequencies. As discussed above, however, oscillator 200 is preferably constructed so as to output a square wave having a frequency of 50 kHz or greater, and more preferably, of 800 kHz or greater. Col. 14:22-28.</p> <p>The `183 Patent disclosed “The combination of oscillator voltage, frequency and transistor gain bandwidth product that is used will necessarily vary with the cost, safety and reliability requirements of a given application.” Col. 14:65 – Col. 15:1.</p>

EE. New Claim 68

`183 Patent Claim Language	`183 Patent Support
<p>68. The capacitive responsive electronic switching circuit as defined in claim 67, wherein the plurality of Hertz values comprises Hertz values greater than 50 kHz.</p>	<p>See Figure 11.</p> <p>The `183 Patent discloses “The touch detection circuit of the present invention features operation at frequencies at or above 50 kHz and preferably at or above 800 kHz to minimize the effects of surface contamination from materials such a [sic] skin oils and water. Col. 5:49-53.</p> <p>The `183 Patent discloses “Conversely, at 100 kHz, the glass impedance drops to approximately 1 MΩ resulting in the impedance of the path to ground for pad 59 being twice that of the touched pad 57. For cases where background noise and temperature drifts are comparatively small, a 100 kHz oscillator frequency would allow a sufficiently low detection threshold to be set to differentiate between the signal changes induced at both pads by a human touch opposite a single pad. At 800 kHz, the impedance of the glass drops to 200 kΩ or lower giving a ratio of a greater than 5 to 1 impedance difference between the paths to</p>

`183 Patent Claim Language	`183 Patent Support
	<p>ground of the touched pad 57 and adjacent pads 59. In fact, the impedance ratio may exceed 10 to 1, as illustrated in the calculation below. This allows the detection threshold for the touched pad to be set well below that of an adjacent pad resulting in a much lower incidence of inadvertent actuation of adjacent touch pads to that of the touched pad. Ideally, the frequency of operation would be kept at the 800 kHz of the preferred embodiment or even higher. However, as noted earlier, higher frequency operation forces the use of more expensive components and designs. For applications where thermal drift and electronic noise levels are low, operation at or near 100 kHz may be possible. However, at 10 kHz and below, the impedance of the glass becomes much greater than that of likely water bridges between pads resulting in adjacent pads being effected as much by a touch as the touched pad itself. Although the preferred frequency is at or above 100 kHz, and more preferably at or above 800 kHz, it is conceivable that frequencies as low as 50 kHz could be used provided the frequency creates a difference in the impedance paths of adjacent pads that is sufficient enough to accurately distinguish between an intended touch and the touch of an adjacent pad. Use of frequencies as low as 50 kHz may also be possible depending upon the type of glass or covering or the thickness thereof used for the touch pad. Col. 10:60 – Col. 11:27.</p> <p>The `183 Patent discloses “As will be apparent to those skilled in the art, the values of the resistors and capacitors utilized in oscillator 200 may be varied from those disclosed above to provide for different oscillator output frequencies. As discussed above, however, oscillator 200 is preferably constructed so as to output a square wave having a frequency of 50 kHz or greater, and more preferably, of 800 kHz or greater. Col. 14:22-28.</p> <p>The `183 Patent disclosed “The combination of</p>

`183 Patent Claim Language	`183 Patent Support
	oscillator voltage, frequency and transistor gain bandwidth product that is used will necessarily vary with the cost, safety and reliability requirements of a given application.” Col. 14:65 – Col. 15:1.

FF. New Claim 69

`183 Patent Claim Language	`183 Patent Support
<p>69. The capacitive responsive electronic switching circuit as defined in claim 67, wherein the plurality of Hertz values comprises Hertz values greater than 100 kHz.</p>	<p>See Figure 11.</p> <p>The `183 Patent discloses “The touch detection circuit of the present invention features operation at frequencies at or above 50 kHz and preferably at or above 800 kHz to minimize the effects of surface contamination from materials such a [sic] skin oils and water. Col. 5:49-53.</p> <p>The `183 Patent discloses “Conversely, at 100 kHz, the glass impedance drops to approximately 1 MΩ resulting in the impedance of the path to ground for pad 59 being twice that of the touched pad 57. For cases where background noise and temperature drifts are comparatively small, a 100 kHz oscillator frequency would allow a sufficiently low detection threshold to be set to differentiate between the signal changes induced at both pads by a human touch opposite a single pad. At 800 kHz, the impedance of the glass drops to 200 kΩ or lower giving a ratio of a greater than 5 to 1 impedance difference between the paths to ground of the touched pad 57 and adjacent pads 59. In fact, the impedance ratio may exceed 10 to 1, as illustrated in the calculation below. This allows the detection threshold for the touched pad to be set well below that of an adjacent pad resulting in a much lower incidence of inadvertent actuation of adjacent touch pads to that of the touched pad. Ideally, the frequency of operation would be kept at the 800 kHz of the preferred embodiment or even higher. However, as noted earlier, higher frequency operation forces the use of more expensive components</p>

`183 Patent Claim Language	`183 Patent Support
	<p>and designs. For applications where thermal drift and electronic noise levels are low, operation at or near 100 kHz may be possible. However, at 10 kHz and below, the impedance of the glass becomes much greater than that of likely water bridges between pads resulting in adjacent pads being effected as much by a touch as the touched pad itself. Although the preferred frequency is at or above 100 kHz, and more preferably at or above 800 kHz, it is conceivable that frequencies as low as 50 kHz could be used provided the frequency creates a difference in the impedance paths of adjacent pads that is sufficient enough to accurately distinguish between an intended touch and the touch of an adjacent pad. Use of frequencies as low as 50 kHz may also be possible depending upon the type of glass or covering or the thickness thereof used for the touch pad. Col. 10:60 – Col. 11:27.</p> <p>The `183 Patent discloses “As will be apparent to those skilled in the art, the values of the resistors and capacitors utilized in oscillator 200 may be varied from those disclosed above to provide for different oscillator output frequencies. As discussed above, however, oscillator 200 is preferably constructed so as to output a square wave having a frequency of 50 kHz or greater, and more preferably, of 800 kHz or greater. Col. 14:22-28.</p> <p>The `183 Patent disclosed “The combination of oscillator voltage, frequency and transistor gain bandwidth product that is used will necessarily vary with the cost, safety and reliability requirements of a given application.” Col. 14:65 – Col. 15:1.</p>

GG. New Claim 70

`183 Patent Claim Language	`183 Patent Support
<p>70. The capacitive responsive electronic switching circuit as defined in claim 67, wherein the plurality of Hertz</p>	<p>See Fig. 11.</p> <p>The `183 Patent discloses “The touch detection</p>

`183 Patent Claim Language	`183 Patent Support
<p>values comprises Hertz values greater than 800 kHz.</p>	<p>circuit of the present invention features operation at frequencies at or above 50 kHz and preferably at or above 800 kHz to minimize the effects of surface contamination from materials such a [sic] skin oils and water. Col. 5:49-53.</p> <p>The `183 Patent discloses “At 800 kHz, the impedance of the glass drops to 200 kΩ or lower giving a ratio of a greater than 5 to 1 impedance difference between the paths to ground of the touched pad 57 and adjacent pads 59. In fact, the impedance ratio may exceed 10 to 1, as illustrated in the calculation below. This allows the detection threshold for the touched pad to be set well below that of an adjacent pad resulting in a much lower incidence of inadvertent actuation of adjacent touch pads to that of the touched pad. Ideally, the frequency of operation would be kept at the 800 kHz of the preferred embodiment or even higher. However, as noted earlier, higher frequency operation forces the use of more expensive components and designs. For applications where thermal drift and electronic noise levels are low, operation at or near 100 kHz may be possible. However, at 10 kHz and below, the impedance of the glass becomes much greater than that of likely water bridges between pads resulting in adjacent pads being effected as much by a touch as the touched pad itself. Although the preferred frequency is at or above 100 kHz, and more preferably at or above 800 kHz, it is conceivable that frequencies as low as 50 kHz could be used provided the frequency creates a difference in the impedance paths of adjacent pads that is sufficient enough to accurately distinguish between an intended touch and the touch of an adjacent pad. Use of frequencies as low as 50 kHz may also be possible depending upon the type of glass or covering or the thickness thereof used for the touch pad. Col. 11:1-27.</p> <p>The `183 Patent discloses “As will be apparent to those skilled in the art, the values of the</p>

`183 Patent Claim Language	`183 Patent Support
	<p>resistors and capacitors utilized in oscillator 200 may be varied from those disclosed above to provide for different oscillator output frequencies. As discussed above, however, oscillator 200 is preferably constructed so as to output a square wave having a frequency of 50 kHz or greater, and more preferably, of 800 kHz or greater. Col. 14:22-28.</p> <p>The `183 Patent disclosed “The combination of oscillator voltage, frequency and transistor gain bandwidth product that is used will necessarily vary with the cost, safety and reliability requirements of a given application.” Col. 14:65 – Col. 15:1.</p>

HH. New Claim 71

`183 Patent Claim Language	`183 Patent Support
<p>71. The capacitive responsive electronic switching circuit as defined in claim 27, wherein the detector circuit is configured to inhibit the control output signal unless the operator is proximal or touches said second touch terminal after the operator is proximal or touches said first touch terminal.</p>	<p>See Figures 19, 20A-C; and Claims 28 and 35.</p> <p>The `183 Patent discloses “In another embodiment a method to prevent inadvertent so actuations is to require a multi-step process. Referring to FIG. 19, a device is shown having a first palm button 2201, a second palm button 2202, and an indicator light 2205. Palm button 2201 has to be activated first and then button 2202 has to be activated within a 2 second time window before a desired actuation can occur.” Col. 22:49-55.</p> <p>The `183 Patent discloses “In a variation of the multi-step process, two touch plates within a housing (one vertical and one horizontal) are used to provide a two-step turn-on. Referring to FIGS. 20A-C, the first step to actuate the output relay 2310, is initiated when the operator inserts his hands and touches the vertical touch sensor 2301 with the dorsal side of the hands. A yellow LED 2304 on top of the device show the successful completion of the first step. The second step is to flip the hand over and touch the horizontal touch sensor 2302 with the palmar</p>

`183 Patent Claim Language	`183 Patent Support
	side of the hand. A red LED 2305 on top of the device shows the completion of the two step turn-on and activation of output relay 2310. The flipping action of the hand in the second step causes the forearm muscles to flex, thereby reducing stiffness and fatigue. Also, the hands, and arms can rest on the run bar until the machine cycle is complete. The second step of the two-step turn-on must occur within some predetermined time (for example 2 seconds) after the release of vertical touch sensor or the first step must be repeated.” Col. 23:19-36.

II. New Claim 72

For ease of analysis, new independent claim 72 is shown below with pseudo-amendments illustrating the differences between new claim 72 and claim 27 of the `183 Patent following the first reexamination proceeding.

`183 Patent Claim Language	`183 Patent Support
72. A capacitive responsive electronic switching circuit for a controlled keypad device comprising:	See Claim 27.
an oscillator providing a periodic output signal having a predefined frequency;	See Claim 27.
a microcontroller using the periodic output signal from the oscillator, the microcontroller selectively providing signal output frequencies <u>directly</u> to a closely spaced array of input touch terminals of a keypad, the input touch terminals comprising first and second input touch terminals;	See Figures 4, 11; and Claims 8, 12, 16. The `183 Patent discloses “The touch detection circuit of the present invention features operation at frequencies at or above 50 kHz and preferably at or above 800 kHz to minimize the effects of surface contamination from materials such a [sic] skin oils and water. It also offers improvements in detection sensitivity that allow close control of the degree of proximity (ideally very close proximity) that is required for actuation and to enable employment of a multiplicity of small sized touch terminals in a physically close array such as a keyboard.” Col.

`183 Patent Claim Language	`183 Patent Support
	<p>5:49-57.</p> <p>The `183 Patent discloses “In a first preferred embodiment the circuit offers enhanced detection sensitivity to allow reliable operation with small (finger size) touch pads.” Col. 6:1-3.</p> <p>The `183 Patent discloses “Although the preferred frequency is at or above 100 kHz, and more preferably at or above 800 kHz, it is conceivable that frequencies as low as 50 kHz could be used provided the frequency creates a difference in the impedance paths of adjacent pads that is sufficient enough to accurately distinguish between an intended touch and the touch of an adjacent pad. Use of frequencies as low as 50 kHz may also be possible depending upon the type of glass or covering or the thickness thereof used for the touch pad.” Col. 11:19-27.</p> <p>The `183 Patent discloses “Upon being powered by voltage regulator 100, oscillator 200 generates a square wave with a frequency of 50 kHz, and preferably greater than 800 kHz, and having an amplitude of 26 V peak. The square wave generated by oscillator 200 is supplied via line 201 to a floating common generator 300, a touch pad shield plate 460, a touch circuit 400, and a microcontroller 500. Oscillator 200 is described below with reference to FIG. 6. Floating common generator 300 receives the 26 V peak square wave from oscillator 200 and outputs a regulated floating common that is 5 volts below the square wave output from oscillator 200 and has the same phase and frequency as the received square wave. This floating common output is supplied to touch circuit 400 and microcontroller 500 via line 301 such that the output square wave from oscillator 200 and floating common output from floating common generator 300 provide power to touch circuit 400 and microcontroller 500. Details of floating common generator 300 are discussed</p>

`183 Patent Claim Language	`183 Patent Support
	<p>below with reference to FIG. 7.</p> <p>Touch circuit 400 senses capacitance from a touch pad 450 via line 451 and outputs a signal to microcontroller 500 via line 401 upon detecting a capacitance to ground at touch pad 450 that exceeds a threshold value. The details of touch circuit 400 are described below with reference to FIG. 8.</p> <p>Upon receiving an indication from touch circuit 400 that a sufficient capacitance to ground (typically at least 20 pF) is present at touch pad 450, microcontroller 500 outputs a signal to a load-controlling microcontroller 600 via line 501, which is preferably a two way optical coupling bus.” Col. 12:6-33.</p> <p>The `183 Patent discloses “As will be apparent to those skilled in the art, the values of the resistors and capacitors utilized in oscillator 200 may be varied from those disclosed above to provide for different oscillator output frequencies.” Col. 14:22-25.</p> <p>The `183 Patent discloses “A multiple touch pad circuit constructed in accordance with the second embodiment is shown in FIG. 11. In the second embodiment of FIG. 11, components similar to those in the first embodiment in FIG. 4 are designated with the same references numerals and will not be discussed in detail.</p> <p>The multiple touch pad circuit is a variation of the first embodiment in that it includes an array of touch circuits designated as 900₁ through 900_{nm}, which, as shown, include both the touch circuit 400 shown in FIGS. 4 and 8 and the input touch terminal pad 451 (FIG. 4).</p> <p>Microcontroller 500 selects each row of the touch circuits 900₁ to 900_{nm} by providing the signal from oscillator 200 to selected rows of touch circuits. In this manner, microcontroller 500 can sequentially activate the touch circuit rows and associate the received inputs from the columns of the array with the activated touch circuit(s). To keep the path length 451 between</p>

`183 Patent Claim Language	`183 Patent Support
	the touch pad 450 and the base to the detection transistor 410 to a minimum, the detection circuits 900 are physically located directly beneath the touch pads. To simplify assembly, a flexible circuit board such as vended by Sheldahl, Inc. or Circuit Etching Technics, Inc. can be used for this purpose. Ideally, the printed circuit will be fixed directly against the surface (typically glass) bearing the conductive touch pads to eliminate air gaps and the need for conductive foam pads and spring contacts which were used to fill air gaps.” Col. 18:34-59.
the first and second input touch terminals defining areas for an operator to provide an input by proximity and touch; and	See Claim 27.
a detector circuit coupled to said oscillator for receiving said periodic output signal from said oscillator, and coupled to said first and second touch terminals, said detector circuit being responsive to signals from said oscillator via said microcontroller and a presence of an operator's body capacitance to ground coupled to said first and second touch terminals when proximal or touched by the operator to provide a control output signal for actuation of the controlled keypad device, said detector circuit being configured to generate said control output signal when the operator is proximal or touches said second touch terminal after the operator is proximal or touches said first touch terminal.	See Claim 27.

JJ. New Claim 73

`183 Patent Claim Language	`183 Patent Support
73. The capacitive responsive electronic switching circuit as defined in claim 72, wherein the signal output	See Figure 11. The `183 Patent discloses “The touch detection circuit of the present invention features operation at frequencies at or above 50 kHz and preferably

`183 Patent Claim Language	`183 Patent Support
<p>frequencies have a same Hertz value.</p>	<p>at or above 800 kHz to minimize the effects of surface contamination from materials such a [sic] skin oils and water. Col. 5:49-53.</p> <p>The `183 Patent discloses “Conversely, at 100 kHz, the glass impedance drops to approximately 1 MΩ resulting in the impedance of the path to ground for pad 59 being twice that of the touched pad 57. For cases where background noise and temperature drifts are comparatively small, a 100 kHz oscillator frequency would allow a sufficiently low detection threshold to be set to differentiate between the signal changes induced at both pads by a human touch opposite a single pad. At 800 kHz, the impedance of the glass drops to 200 kΩ or lower giving a ratio of a greater than 5 to 1 impedance difference between the paths to ground of the touched pad 57 and adjacent pads 59. In fact, the impedance ratio may exceed 10 to 1, as illustrated in the calculation below. This allows the detection threshold for the touched pad to be set well below that of an adjacent pad resulting in a much lower incidence of inadvertent actuation of adjacent touch pads to that of the touched pad. Ideally, the frequency of operation would be kept at the 800 kHz of the preferred embodiment or even higher. However, as noted earlier, higher frequency operation forces the use of more expensive components and designs. For applications where thermal drift and electronic noise levels are low, operation at or near 100 kHz may be possible. However, at 10 kHz and below, the impedance of the glass becomes much greater than that of likely water bridges between pads resulting in adjacent pads being effected as much by a touch as the touched pad itself. Although the preferred frequency is at or above 100 kHz, and more preferably at or above 800 kHz, it is conceivable that frequencies as low as 50 kHz could be used provided the frequency creates a difference in the impedance paths of adjacent pads that is sufficient enough to accurately distinguish between an intended</p>

`183 Patent Claim Language	`183 Patent Support
	<p>touch and the touch of an adjacent pad. Use of frequencies as low as 50 kHz may also be possible depending upon the type of glass or covering or the thickness thereof used for the touch pad. Col. 10:60 – Col. 11:27.</p> <p>The `183 Patent discloses “As will be apparent to those skilled in the art, the values of the resistors and capacitors utilized in oscillator 200 may be varied from those disclosed above to provide for different oscillator output frequencies. As discussed above, however, oscillator 200 is preferably constructed so as to output a square wave having a frequency of 50 kHz or greater, and more preferably, of 800 kHz or greater. Col. 14:22-28.</p> <p>The `183 Patent disclosed “The combination of oscillator voltage, frequency and transistor gain bandwidth product that is used will necessarily vary with the cost, safety and reliability requirements of a given application.” Col. 14:65 – Col. 15:1.</p>

KK. New Claim 74

`183 Patent Claim Language	`183 Patent Support
<p>74. The capacitive responsive electronic switching circuit as defined in claim 72, wherein each signal output frequency is selected from a plurality of Hertz values.</p>	<p>See Figure 11.</p> <p>The `183 Patent discloses “The touch detection circuit of the present invention features operation at frequencies at or above 50 kHz and preferably at or above 800 kHz to minimize the effects of surface contamination from materials such a [sic] skin oils and water. Col. 5:49-53.</p> <p>The `183 Patent discloses “Conversely, at 100 kHz, the glass impedance drops to approximately 1 MΩ resulting in the impedance of the path to ground for pad 59 being twice that of the touched pad 57. For cases where background noise and temperature drifts are comparatively small, a 100 kHz oscillator frequency would allow a sufficiently low</p>

`183 Patent Claim Language	`183 Patent Support
	<p>detection threshold to be set to differentiate between the signal changes induced at both pads by a human touch opposite a single pad. At 800 kHz, the impedance of the glass drops to 200 kΩ or lower giving a ratio of a greater than 5 to 1 impedance difference between the paths to ground of the touched pad 57 and adjacent pads 59. In fact, the impedance ratio may exceed 10 to 1, as illustrated in the calculation below. This allows the detection threshold for the touched pad to be set well below that of an adjacent pad resulting in a much lower incidence of inadvertent actuation of adjacent touch pads to that of the touched pad. Ideally, the frequency of operation would be kept at the 800 kHz of the preferred embodiment or even higher. However, as noted earlier, higher frequency operation forces the use of more expensive components and designs. For applications where thermal drift and electronic noise levels are low, operation at or near 100 kHz may be possible. However, at 10 kHz and below, the impedance of the glass becomes much greater than that of likely water bridges between pads resulting in adjacent pads being effected as much by a touch as the touched pad itself. Although the preferred frequency is at or above 100 kHz, and more preferably at or above 800 kHz, it is conceivable that frequencies as low as 50 kHz could be used provided the frequency creates a difference in the impedance paths of adjacent pads that is sufficient enough to accurately distinguish between an intended touch and the touch of an adjacent pad. Use of frequencies as low as 50 kHz may also be possible depending upon the type of glass or covering or the thickness thereof used for the touch pad. Col. 10:60 – Col. 11:27.</p> <p>The `183 Patent discloses “As will be apparent to those skilled in the art, the values of the resistors and capacitors utilized in oscillator 200 may be varied from those disclosed above to provide for different oscillator output frequencies. As discussed above, however,</p>

`183 Patent Claim Language	`183 Patent Support
	<p>oscillator 200 is preferably constructed so as to output a square wave having a frequency of 50 kHz or greater, and more preferably, of 800 kHz or greater. Col. 14:22-28.</p> <p>The `183 Patent disclosed “The combination of oscillator voltage, frequency and transistor gain bandwidth product that is used will necessarily vary with the cost, safety and reliability requirements of a given application.” Col. 14:65 – Col. 15:1.</p>

LL. New Claim 75

`183 Patent Claim Language	`183 Patent Support
<p>75. The capacitive responsive electronic switching circuit as defined in claim 74, wherein the plurality of Hertz values comprises Hertz values greater than 50 kHz.</p>	<p>See Figure 11.</p> <p>The `183 Patent discloses “The touch detection circuit of the present invention features operation at frequencies at or above 50 kHz and preferably at or above 800 kHz to minimize the effects of surface contamination from materials such a [sic] skin oils and water. Col. 5:49-53.</p> <p>The `183 Patent discloses “Conversely, at 100 kHz, the glass impedance drops to approximately 1 MΩ resulting in the impedance of the path to ground for pad 59 being twice that of the touched pad 57. For cases where background noise and temperature drifts are comparatively small, a 100 kHz oscillator frequency would allow a sufficiently low detection threshold to be set to differentiate between the signal changes induced at both pads by a human touch opposite a single pad. At 800 kHz, the impedance of the glass drops to 200 kΩ or lower giving a ratio of a greater than 5 to 1 impedance difference between the paths to ground of the touched pad 57 and adjacent pads 59. In fact, the impedance ratio may exceed 10 to 1, as illustrated in the calculation below. This allows the detection threshold for the touched pad to be set well below that of an adjacent pad resulting in a much lower incidence of</p>

`183 Patent Claim Language	`183 Patent Support
	<p>inadvertent actuation of adjacent touch pads to that of the touched pad. Ideally, the frequency of operation would be kept at the 800 kHz of the preferred embodiment or even higher. However, as noted earlier, higher frequency operation forces the use of more expensive components and designs. For applications where thermal drift and electronic noise levels are low, operation at or near 100 kHz may be possible. However, at 10 kHz and below, the impedance of the glass becomes much greater than that of likely water bridges between pads resulting in adjacent pads being effected as much by a touch as the touched pad itself. Although the preferred frequency is at or above 100 kHz, and more preferably at or above 800 kHz, it is conceivable that frequencies as low as 50 kHz could be used provided the frequency creates a difference in the impedance paths of adjacent pads that is sufficient enough to accurately distinguish between an intended touch and the touch of an adjacent pad. Use of frequencies as low as 50 kHz may also be possible depending upon the type of glass or covering or the thickness thereof used for the touch pad. Col. 10:60 – Col. 11:27.</p> <p>The `183 Patent discloses “As will be apparent to those skilled in the art, the values of the resistors and capacitors utilized in oscillator 200 may be varied from those disclosed above to provide for different oscillator output frequencies. As discussed above, however, oscillator 200 is preferably constructed so as to output a square wave having a frequency of 50 kHz or greater, and more preferably, of 800 kHz or greater. Col. 14:22-28.</p> <p>The `183 Patent disclosed “The combination of oscillator voltage, frequency and transistor gain bandwidth product that is used will necessarily vary with the cost, safety and reliability requirements of a given application.” Col. 14:65 – Col. 15:1.</p>

MM. New Claim 76

`183 Patent Claim Language	`183 Patent Support
<p>76. The capacitive responsive electronic switching circuit as defined in claim 74, wherein the plurality of Hertz values comprises Hertz values greater than 100 kHz.</p>	<p>See Figure 11.</p> <p>The `183 Patent discloses “The touch detection circuit of the present invention features operation at frequencies at or above 50 kHz and preferably at or above 800 kHz to minimize the effects of surface contamination from materials such a [sic] skin oils and water. Col. 5:49-53.</p> <p>The `183 Patent discloses “Conversely, at 100 kHz, the glass impedance drops to approximately 1 MΩ resulting in the impedance of the path to ground for pad 59 being twice that of the touched pad 57. For cases where background noise and temperature drifts are comparatively small, a 100 kHz oscillator frequency would allow a sufficiently low detection threshold to be set to differentiate between the signal changes induced at both pads by a human touch opposite a single pad. At 800 kHz, the impedance of the glass drops to 200 kΩ or lower giving a ratio of a greater than 5 to 1 impedance difference between the paths to ground of the touched pad 57 and adjacent pads 59. In fact, the impedance ratio may exceed 10 to 1, as illustrated in the calculation below. This allows the detection threshold for the touched pad to be set well below that of an adjacent pad resulting in a much lower incidence of inadvertent actuation of adjacent touch pads to that of the touched pad. Ideally, the frequency of operation would be kept at the 800 kHz of the preferred embodiment or even higher. However, as noted earlier, higher frequency operation forces the use of more expensive components and designs. For applications where thermal drift and electronic noise levels are low, operation at or near 100 kHz may be possible. However, at 10 kHz and below, the impedance of the glass becomes much greater than that of likely water bridges between pads resulting in adjacent pads being effected as much by a touch as the touched pad itself. Although the preferred frequency is at</p>

`183 Patent Claim Language	`183 Patent Support
	<p>or above 100 kHz, and more preferably at or above 800 kHz, it is conceivable that frequencies as low as 50 kHz could be used provided the frequency creates a difference in the impedance paths of adjacent pads that is sufficient enough to accurately distinguish between an intended touch and the touch of an adjacent pad. Use of frequencies as low as 50 kHz may also be possible depending upon the type of glass or covering or the thickness thereof used for the touch pad. Col. 10:60 – Col. 11:27.</p> <p>The `183 Patent discloses “As will be apparent to those skilled in the art, the values of the resistors and capacitors utilized in oscillator 200 may be varied from those disclosed above to provide for different oscillator output frequencies. As discussed above, however, oscillator 200 is preferably constructed so as to output a square wave having a frequency of 50 kHz or greater, and more preferably, of 800 kHz or greater. Col. 14:22-28.</p> <p>The `183 Patent disclosed “The combination of oscillator voltage, frequency and transistor gain bandwidth product that is used will necessarily vary with the cost, safety and reliability requirements of a given application.” Col. 14:65 – Col. 15:1.</p>

NN. New Claim 77

`183 Patent Claim Language	`183 Patent Support
<p>77. The capacitive responsive electronic switching circuit as defined in claim 74, wherein the plurality of Hertz values comprises Hertz values greater than 800 kHz.</p>	<p>See Fig. 11.</p> <p>The `183 Patent discloses “The touch detection circuit of the present invention features operation at frequencies at or above 50 kHz and preferably at or above 800 kHz to minimize the effects of surface contamination from materials such a [sic] skin oils and water. Col. 5:49-53.</p> <p>The `183 Patent discloses “At 800 kHz, the impedance of the glass drops to 200 kΩ or lower</p>

`183 Patent Claim Language	`183 Patent Support
	<p>giving a ratio of a greater than 5 to 1 impedance difference between the paths to ground of the touched pad 57 and adjacent pads 59. In fact, the impedance ratio may exceed 10 to 1, as illustrated in the calculation below. This allows the detection threshold for the touched pad to be set well below that of an adjacent pad resulting in a much lower incidence of inadvertent actuation of adjacent touch pads to that of the touched pad. Ideally, the frequency of operation would be kept at the 800 kHz of the preferred embodiment or even higher. However, as noted earlier, higher frequency operation forces the use of more expensive components and designs. For applications where thermal drift and electronic noise levels are low, operation at or near 100 kHz may be possible. However, at 10 kHz and below, the impedance of the glass becomes much greater than that of likely water bridges between pads resulting in adjacent pads being effected as much by a touch as the touched pad itself. Although the preferred frequency is at or above 100 kHz, and more preferably at or above 800 kHz, it is conceivable that frequencies as low as 50 kHz could be used provided the frequency creates a difference in the impedance paths of adjacent pads that is sufficient enough to accurately distinguish between an intended touch and the touch of an adjacent pad. Use of frequencies as low as 50 kHz may also be possible depending upon the type of glass or covering or the thickness thereof used for the touch pad. Col. 11:1-27.</p> <p>The `183 Patent discloses “As will be apparent to those skilled in the art, the values of the resistors and capacitors utilized in oscillator 200 may be varied from those disclosed above to provide for different oscillator output frequencies. As discussed above, however, oscillator 200 is preferably constructed so as to output a square wave having a frequency of 50 kHz or greater, and more preferably, of 800 kHz or greater. Col. 14:22-28.</p>

`183 Patent Claim Language	`183 Patent Support
	The `183 Patent disclosed “The combination of oscillator voltage, frequency and transistor gain bandwidth product that is used will necessarily vary with the cost, safety and reliability requirements of a given application.” Col. 14:65 – Col. 15:1.

OO. New Claim 78

For ease of analysis, new dependent claim 78 is shown below with pseudo-amendments illustrating the differences between new claim 78 and claim 28 of the `183 Patent following the first reexamination proceeding.

`183 Patent Claim Language	`183 Patent Support
78. The capacitive responsive electronic switching circuit as defined in claim 72, wherein said detector circuit generates <u>is configured to generate</u> said control <u>output</u> signal only when the operator is proximal or touches said second touch terminal within a predetermined time period after the operator is proximal or touches said first touch terminal.	See Claims 27 and 28.

PP. New Claim 79

For ease of analysis, new dependent claim 79 is shown below with pseudo-amendments illustrating the differences between new claim 79 and claim 36 of the `183 Patent following the first reexamination proceeding.

`183 Patent Claim Language	`183 Patent Support
79. The capacitive responsive electronic switching circuit as defined in claim 72, and further including <u>comprising</u> an indicator for indicating when said the detector circuit determines <u>has determined</u> that the operator is	See Claims 32 and 36. The `183 Patent discloses “The microprocessor also allows the use of visual indicators such as LEDs or annunciators such as a bell or tone generator to confirm the actuation of a given

`183 Patent Claim Language	`183 Patent Support
<p>proximal or touches said second touch terminal.</p>	<p>touch switch or switches. This is particularly useful in cases where a sequence of actuations is required before an action occurs. The feedback to the operator provided by a visual or audio indicator activated by the microprocessor in response to intermediate touches in a required sequence can minimize time lost and/or frustration on the part of the operator due to failed actuations from partial touches or wrong actuations from touching the wrong pad in a given required sequence or combination of touches.” Col. 6:31-42.</p> <p>The `183 Patent discloses “A further option is to provide one or more LEDs 2205 or audible annunciators for visual or audible feedback to the operator. Specifically, in FIG. 19 the LED 2205 will come on when button 2201 has been successfully activated to cue the operator that it is time to move to button 2202. Where required a second LED with a different color than the first (yellow for the first LED and red for the second) can be provided to provide visual confirmation that the second button 2202 has been activated or that the required combination of the two buttons has been activated. Two different audible tone or sound generators could also be used in lieu of the LEDs to provide feedback to the operator.” Col. 23:1-12.</p> <p>The `183 Patent discloses “A red LED 2305 on top of the device shows the completion of the two step turn-on and activation of output relay 2310.” Col. 23:28-30.</p>

QQ. New Claim 80

`183 Patent Claim Language	`183 Patent Support
<p>80. The capacitive responsive electronic switching circuit as defined in claim 72, wherein the detector circuit is configured to inhibit the control output signal unless the operator is proximal or touches said second touch terminal after</p>	<p>See Figures 19, 20A-C; and Claims 28 and 35.</p> <p>The `183 Patent discloses “In another embodiment a method to prevent inadvertent so actuations is to require a multi-step process. Referring to FIG. 19, a device is shown having a</p>

`183 Patent Claim Language	`183 Patent Support
<p>the operator is proximal or touches said first touch terminal.</p>	<p>first palm button 2201, a second palm button 2202, and an indicator light 2205. Palm button 2201 has to be activated first and then button 2202 has to be activated within a 2 second time window before a desired actuation can occur.” Col. 22:49-55.</p> <p>The `183 Patent discloses “In a variation of the multi-step process, two touch plates within a housing (one vertical and one horizontal) are used to provide a two-step turn-on. Referring to FIGS. 20A-C, the first step to actuate the output relay 2310, is initiated when the operator inserts his hands and touches the vertical touch sensor 2301 with the dorsal side of the hands. A yellow LED 2304 on top of the device show the successful completion of the first step. The second step is to flip the hand over and touch the horizontal touch sensor 2302 with the palmar side of the hand. A red LED 2305 on top of the device shows the completion of the two step turn-on and activation of output relay 2310. The flipping action of the hand in the second step causes the forearm muscles to flex, thereby reducing stiffness and fatigue. Also, the hands, and arms can rest on the run bar until the machine cycle is complete. The second step of the two-step turn-on must occur within some predetermined time (for example 2 seconds) after the release of vertical touch sensor or the first step must be repeated.” Col. 23:19-36.</p>

RR. New Claim 81

`183 Patent Claim Language	`183 Patent Support
<p>81. The capacitive responsive electronic switching circuit as defined in claim 72, wherein a peak voltage of the signal output frequencies is greater than a supply voltage.</p>	<p>See Figures 4, 5; Claims 27 and 37.</p> <p>The `183 Patent discloses “Having provided a basis for the use of higher frequencies, the basic construction of the electronic switching circuit constructed in accordance with a first embodiment of the present invention is now described with reference to FIG. 4. The electronic switching circuit includes a voltage</p>

`183 Patent Claim Language	`183 Patent Support
	<p>regulator 100 including input lines 101 and 102 for receiving a 24 V AC line voltage and a line 103 for grounding the circuit. Voltage regulator 100 converts the received AC voltage to a DC voltage and supplies a regulated 5 V DC power to an oscillator 200 via lines 104 and 105. Voltage regulator also supplies oscillator 200 with 26 V DC power via line 106. The details of voltage regulator 100 are discussed below with reference to FIG. 5.</p> <p>Upon being powered by voltage regulator 100, oscillator 200 generates a square wave with a frequency of 50 kHz, and preferably greater than 800 kHz, and having an amplitude of 26 V peak. The square wave generated by oscillator 200 is supplied via line 201 to a floating common generator 300, a touch pad shield plate 460, a touch circuit 400, and a microcontroller 500. Oscillator 200 is described below with reference to FIG. 6.” Col. 11:60 – Col. 12:13.</p> <p>The `183 Patent discloses “Microcontroller 500 selects each row of the touch circuits 900₁ to 900_{nm} by providing the signal from oscillator 200 to selected rows of touch circuits. In this manner, microcontroller 500 can sequentially activate the touch circuit rows and associate the received inputs from the columns of the array with the activated touch circuit(s).” Col. 18:43-49.</p> <p>The `183 Patent discloses “A preferred circuit for implementing a voltage regulator 100 is shown in FIG. 5. Voltage regulator 100 preferably includes an AC/DC convertor 110 for generating 29 V to 36 V unregulated DC on line 119. This unregulated DC power is supplied to a 5 V DC regulator 120 and to a 26 V DC regulator 130. AC/DC convertor 110 includes diodes 112, 114, 116, and 118, which rectify the supplied 24 V AC power provided on power lines 101 and 102.” Col. 12:50-57; see also Col. 12:57 – Col. 13:31.</p>

`183 Patent Claim Language	`183 Patent Support
	<p>The `183 Patent discloses “The oscillator circuitry shown in FIG. 6 is very stable over the temperature range of -40° C. to 105° C. The output of the touch switch circuitry drops at a rate of approximately 40 mV/°C. when temperature falls below 0° C. If application requires operation at low temperatures (-40° C.), the following three methods may be used to increase the output of the switch: increase the oscillator’s regulated supply voltage, increase the resistance of resistor 416, and use a higher gain transistor 410. All of these methods would increase sensitivity at high temperatures.” Col. 16:33-41.</p>

SS. New Claim 82

`183 Patent Claim Language	`183 Patent Support
<p>82. The capacitive responsive electronic switching circuit as defined in claim 81, wherein the supply voltage is a battery supply voltage.</p>	<p>The `183 Patent discloses “It will be apparent to those skilled in the art, that various components of voltage regulator 100 may be added or excluded depending upon the source of power available to power the oscillator 200. For example, if the available power is a 110 V AC 60 Hz commercial power line, a transformer may be added to convert the 100 V AC power to 24 V AC. Alternatively, if a DC batter is used, the AC/DC convertor among other components may be eliminated.” Col 13:23-31.</p>

TT. New Claim 83

`183 Patent Claim Language	`183 Patent Support
<p>83. The capacitive responsive electronic switching circuit as defined in claim 81, wherein the supply voltage is a voltage regulator supply voltage.</p>	<p>Figures 4, 5, 11, and 12.</p> <p>The `183 Patent discloses “The electronic switching circuit includes a voltage regulator 100 including input lines 101 and 102 for receiving a 24 V AC line voltage and a line 103 for grounding the circuit. Voltage regulator 100 converts the received AC voltage to a DC voltage and supplies a regulated 5 V DC power to an oscillator 200 via lines 104 and 105.</p>

`183 Patent Claim Language	`183 Patent Support
	Voltage regulator also supplies oscillator 200 with 26 V DC power via line 106. The details of voltage regulator 100 are discussed below with reference to FIG. 5.” Col. 11:64 – Col. 12:5; see also Col. 12:50 – Col. 13:31.

UU. New Claim 84

For ease of analysis, new independent claim 84 is shown below with pseudo-amendments illustrating the differences between new claim 84 and claim 27 of the `183 Patent following the first reexamination proceeding.

`183 Patent Claim Language	`183 Patent Support
84. A capacitive responsive electronic switching circuit for a controlled keypad device comprising:	See Claim 27.
an oscillator providing a periodic output signal having a predefined frequency;	See Claim 27.
a microcontroller using the periodic output signal from the oscillator, the microcontroller selectively providing signal output frequencies to a closely spaced array of input touch terminals of a keypad, the input touch terminals comprising first and second input touch terminals, <u>wherein a peak voltage of the signal output frequencies is greater than a supply voltage;</u>	<p>See Figures 4, 5, 11; and Claims 8, 12, 16, 27 and 37.</p> <p>The `183 Patent discloses “The touch detection circuit of the present invention features operation at frequencies at or above 50 kHz and preferably at or above 800 kHz to minimize the effects of surface contamination from materials such a [sic] skin oils and water. It also offers improvements in detection sensitivity that allow close control of the degree of proximity (ideally very close proximity) that is required for actuation and to enable employment of a multiplicity of small sized touch terminals in a physically close array such as a keyboard.” Col. 5:49-57.</p> <p>The `183 Patent discloses “In a first preferred embodiment the circuit offers enhanced detection sensitivity to allow reliable operation with small (finger size) touch pads.” Col. 6:1-3.</p>

`183 Patent Claim Language	`183 Patent Support
	<p>The `183 Patent discloses “Although the preferred frequency is at or above 100 kHz, and more preferably at or above 800 kHz, it is conceivable that frequencies as low as 50 kHz could be used provided the frequency creates a difference in the impedance paths of adjacent pads that is sufficient enough to accurately distinguish between an intended touch and the touch of an adjacent pad. Use of frequencies as low as 50 kHz may also be possible depending upon the type of glass or covering or the thickness thereof used for the touch pad.” Col. 11:19-27.</p> <p>The `183 Patent discloses “Having provided a basis for the use of higher frequencies, the basic construction of the electronic switching circuit constructed in accordance with a first embodiment of the present invention is now described with reference to FIG. 4. The electronic switching circuit includes a voltage regulator 100 including input lines 101 and 102 for receiving a 24 V AC line voltage and a line 103 for grounding the circuit. Voltage regulator 100 converts the received AC voltage to a DC voltage and supplies a regulated 5 V DC power to an oscillator 200 via lines 104 and 105. Voltage regulator also supplies oscillator 200 with 26 V DC power via line 106. The details of voltage regulator 100 are discussed below with reference to FIG. 5.</p> <p>Upon being powered by voltage regulator 100, oscillator 200 generates a square wave with a frequency of 50 kHz, and preferably greater than 800 kHz, and having an amplitude of 26 V peak. The square wave generated by oscillator 200 is supplied via line 201 to a floating common generator 300, a touch pad shield plate 460, a touch circuit 400, and a microcontroller 500. Oscillator 200 is described below with reference to FIG. 6.</p> <p>Floating common generator 300 receives the 26 V peak square wave from oscillator 200 and outputs a regulated floating common that is 5</p>

`183 Patent Claim Language	`183 Patent Support
	<p>volts below the square wave output from oscillator 200 and has the same phase and frequency as the received square wave. This floating common output is supplied to touch circuit 400 and microcontroller 500 via line 301 such that the output square wave from oscillator 200 and floating common output from floating common generator 300 provide power to touch circuit 400 and microcontroller 500. Details of floating common generator 300 are discussed below with reference to FIG. 7.</p> <p>Touch circuit 400 senses capacitance from a touch pad 450 via line 451 and outputs a signal to microcontroller 500 via line 401 upon detecting a capacitance to ground at touch pad 450 that exceeds a threshold value. The details of touch circuit 400 are described below with reference to FIG. 8.</p> <p>Upon receiving an indication from touch circuit 400 that a sufficient capacitance to ground (typically at least 20 pF) is present at touch pad 450, microcontroller 500 outputs a signal to a load-controlling microcontroller 600 via line 501, which is preferably a two way optical coupling bus.” Col. 11:60 – 12:33.</p> <p>The `183 Patent discloses “A preferred circuit for implementing a voltage regulator 100 is shown in FIG. 5. Voltage regulator 100 preferably includes an AC/DC convertor 110 for generating 29 V to 36 V unregulated DC on line 119. This unregulated DC power is supplied to a 5 V DC regulator 120 and to a 26 V DC regulator 130. AC/DC convertor 110 includes diodes 112, 114, 116, and 118, which rectify the supplied 24 V AC power provided on power lines 101 and 102.” Col. 12:50-57; see also Col. 12:57 – Col. 13:31.</p> <p>The `183 Patent discloses “As will be apparent to those skilled in the art, the values of the resistors and capacitors utilized in oscillator 200 may be varied from those disclosed above to provide for different oscillator output</p>

`183 Patent Claim Language	`183 Patent Support
	<p>frequencies.” Col. 14:22-25.</p> <p>The `183 Patent discloses “The oscillator circuitry shown in FIG. 6 is very stable over the temperature range of -40° C. to 105° C. The output of the touch switch circuitry drops at a rate of approximately 40 mV/°C. when temperature falls below 0° C. If application requires operation at low temperatures (-40° C.), the following three methods may be used to increase the output of the switch: increase the oscillator’s regulated supply voltage, increase the resistance of resistor 416, and use a higher gain transistor 410. All of these methods would increase sensitivity at high temperatures.” Col. 16:33-41.</p> <p>The `183 Patent discloses “A multiple touch pad circuit constructed in accordance with the second embodiment is shown in FIG. 11. In the second embodiment of FIG. 11, components similar to those in the first embodiment in FIG. 4 are designated with the same references numerals and will not be discussed in detail. The multiple touch pad circuit is a variation of the first embodiment in that it includes an array of touch circuits designated as 900₁ through 900_{nm}, which, as shown, include both the touch circuit 400 shown in FIGS. 4 and 8 and the input touch terminal pad 451 (FIG. 4). Microcontroller 500 selects each row of the touch circuits 900₁ to 900_{nm} by providing the signal from oscillator 200 to selected rows of touch circuits. In this manner, microcontroller 500 can sequentially activate the touch circuit rows and associate the received inputs from the columns of the array with the activated touch circuit(s). To keep the path length 451 between the touch pad 450 and the base to the detection transistor 410 to a minimum, the detection circuits 900 are physically located directly beneath the touch pads. To simplify assembly, a flexible circuit board such as vended by Sheldahl, Inc. or Circuit Etching Technics, Inc.</p>

`183 Patent Claim Language	`183 Patent Support
	can be used for this purpose. Ideally, the printed circuit will be fixed directly against the surface (typically glass) bearing the conductive touch pads to eliminate air gaps and the need for conductive foam pads and spring contacts which were used to fill air gaps.” Col. 18:34-59.
the first and second input touch terminals defining areas for an operator to provide an input by proximity and touch; and	See Claim 27.
a detector circuit coupled to said oscillator for receiving said periodic output signal from said oscillator, and coupled to said first and second touch terminals, said detector circuit being responsive to signals from said oscillator via said microcontroller and a presence of an operator's body capacitance to ground coupled to said first and second touch terminals when proximal or touched by the operator to provide a control output signal for actuation of the controlled keypad device, said detector circuit being configured to generate said control output signal when the operator is proximal or touches said second touch terminal after the operator is proximal or touches said first touch terminal.	See Claim 27.

VV. New Claim 85

`183 Patent Claim Language	`183 Patent Support
85. The capacitive responsive electronic switching circuit as defined in claim 84, wherein the signal output frequencies have a same Hertz value.	<p>See Figure 11.</p> <p>The `183 Patent discloses “The touch detection circuit of the present invention features operation at frequencies at or above 50 kHz and preferably at or above 800 kHz to minimize the effects of surface contamination from materials such a [sic] skin oils and water. Col. 5:49-53.</p> <p>The `183 Patent discloses “Conversely, at 100 kHz, the glass impedance drops to</p>

`183 Patent Claim Language	`183 Patent Support
	<p>approximately 1 MΩ resulting in the impedance of the path to ground for pad 59 being twice that of the touched pad 57. For cases where background noise and temperature drifts are comparatively small, a 100 kHz oscillator frequency would allow a sufficiently low detection threshold to be set to differentiate between the signal changes induced at both pads by a human touch opposite a single pad. At 800 kHz, the impedance of the glass drops to 200 kΩ or lower giving a ratio of a greater than 5 to 1 impedance difference between the paths to ground of the touched pad 57 and adjacent pads 59. In fact, the impedance ratio may exceed 10 to 1, as illustrated in the calculation below. This allows the detection threshold for the touched pad to be set well below that of an adjacent pad resulting in a much lower incidence of inadvertent actuation of adjacent touch pads to that of the touched pad. Ideally, the frequency of operation would be kept at the 800 kHz of the preferred embodiment or even higher. However, as noted earlier, higher frequency operation forces the use of more expensive components and designs. For applications where thermal drift and electronic noise levels are low, operation at or near 100 kHz may be possible. However, at 10 kHz and below, the impedance of the glass becomes much greater than that of likely water bridges between pads resulting in adjacent pads being effected as much by a touch as the touched pad itself. Although the preferred frequency is at or above 100 kHz, and more preferably at or above 800 kHz, it is conceivable that frequencies as low as 50 kHz could be used provided the frequency creates a difference in the impedance paths of adjacent pads that is sufficient enough to accurately distinguish between an intended touch and the touch of an adjacent pad. Use of frequencies as low as 50 kHz may also be possible depending upon the type of glass or covering or the thickness thereof used for the touch pad. Col. 10:60 – Col. 11:27.</p>

`183 Patent Claim Language	`183 Patent Support
	<p>The `183 Patent discloses “As will be apparent to those skilled in the art, the values of the resistors and capacitors utilized in oscillator 200 may be varied from those disclosed above to provide for different oscillator output frequencies. As discussed above, however, oscillator 200 is preferably constructed so as to output a square wave having a frequency of 50 kHz or greater, and more preferably, of 800 kHz or greater. Col. 14:22-28.</p> <p>The `183 Patent disclosed “The combination of oscillator voltage, frequency and transistor gain bandwidth product that is used will necessarily vary with the cost, safety and reliability requirements of a given application.” Col. 14:65 – Col. 15:1.</p>

WW. New Claim 86

`183 Patent Claim Language	`183 Patent Support
<p>86. The capacitive responsive electronic switching circuit as defined in claim 84, wherein each signal output frequency is selected from a plurality of Hertz values.</p>	<p>See Figure 11.</p> <p>The `183 Patent discloses “The touch detection circuit of the present invention features operation at frequencies at or above 50 kHz and preferably at or above 800 kHz to minimize the effects of surface contamination from materials such a [sic] skin oils and water. Col. 5:49-53.</p> <p>The `183 Patent discloses “Conversely, at 100 kHz, the glass impedance drops to approximately 1 MΩ resulting in the impedance of the path to ground for pad 59 being twice that of the touched pad 57. For cases where background noise and temperature drifts are comparatively small, a 100 kHz oscillator frequency would allow a sufficiently low detection threshold to be set to differentiate between the signal changes induced at both pads by a human touch opposite a single pad. At 800 kHz, the impedance of the glass drops to 200 kΩ or lower giving a ratio of a greater than 5 to 1 impedance difference between the paths to</p>

`183 Patent Claim Language	`183 Patent Support
	<p>ground of the touched pad 57 and adjacent pads 59. In fact, the impedance ratio may exceed 10 to 1, as illustrated in the calculation below. This allows the detection threshold for the touched pad to be set well below that of an adjacent pad resulting in a much lower incidence of inadvertent actuation of adjacent touch pads to that of the touched pad. Ideally, the frequency of operation would be kept at the 800 kHz of the preferred embodiment or even higher. However, as noted earlier, higher frequency operation forces the use of more expensive components and designs. For applications where thermal drift and electronic noise levels are low, operation at or near 100 kHz may be possible. However, at 10 kHz and below, the impedance of the glass becomes much greater than that of likely water bridges between pads resulting in adjacent pads being effected as much by a touch as the touched pad itself. Although the preferred frequency is at or above 100 kHz, and more preferably at or above 800 kHz, it is conceivable that frequencies as low as 50 kHz could be used provided the frequency creates a difference in the impedance paths of adjacent pads that is sufficient enough to accurately distinguish between an intended touch and the touch of an adjacent pad. Use of frequencies as low as 50 kHz may also be possible depending upon the type of glass or covering or the thickness thereof used for the touch pad. Col. 10:60 – Col. 11:27.</p> <p>The `183 Patent discloses “As will be apparent to those skilled in the art, the values of the resistors and capacitors utilized in oscillator 200 may be varied from those disclosed above to provide for different oscillator output frequencies. As discussed above, however, oscillator 200 is preferably constructed so as to output a square wave having a frequency of 50 kHz or greater, and more preferably, of 800 kHz or greater. Col. 14:22-28.</p> <p>The `183 Patent disclosed “The combination of</p>

`183 Patent Claim Language	`183 Patent Support
	oscillator voltage, frequency and transistor gain bandwidth product that is used will necessarily vary with the cost, safety and reliability requirements of a given application.” Col. 14:65 – Col. 15:1.

XX. New Claim 87

`183 Patent Claim Language	`183 Patent Support
<p>87. The capacitive responsive electronic switching circuit as defined in claim 86, wherein the plurality of Hertz values comprises Hertz values greater than 50 kHz.</p>	<p>See Figure 11.</p> <p>The `183 Patent discloses “The touch detection circuit of the present invention features operation at frequencies at or above 50 kHz and preferably at or above 800 kHz to minimize the effects of surface contamination from materials such a [sic] skin oils and water. Col. 5:49-53.</p> <p>The `183 Patent discloses “Conversely, at 100 kHz, the glass impedance drops to approximately 1 MΩ resulting in the impedance of the path to ground for pad 59 being twice that of the touched pad 57. For cases where background noise and temperature drifts are comparatively small, a 100 kHz oscillator frequency would allow a sufficiently low detection threshold to be set to differentiate between the signal changes induced at both pads by a human touch opposite a single pad. At 800 kHz, the impedance of the glass drops to 200 kΩ or lower giving a ratio of a greater than 5 to 1 impedance difference between the paths to ground of the touched pad 57 and adjacent pads 59. In fact, the impedance ratio may exceed 10 to 1, as illustrated in the calculation below. This allows the detection threshold for the touched pad to be set well below that of an adjacent pad resulting in a much lower incidence of inadvertent actuation of adjacent touch pads to that of the touched pad. Ideally, the frequency of operation would be kept at the 800 kHz of the preferred embodiment or even higher. However, as noted earlier, higher frequency operation forces the use of more expensive components</p>

`183 Patent Claim Language	`183 Patent Support
	<p>and designs. For applications where thermal drift and electronic noise levels are low, operation at or near 100 kHz may be possible. However, at 10 kHz and below, the impedance of the glass becomes much greater than that of likely water bridges between pads resulting in adjacent pads being effected as much by a touch as the touched pad itself. Although the preferred frequency is at or above 100 kHz, and more preferably at or above 800 kHz, it is conceivable that frequencies as low as 50 kHz could be used provided the frequency creates a difference in the impedance paths of adjacent pads that is sufficient enough to accurately distinguish between an intended touch and the touch of an adjacent pad. Use of frequencies as low as 50 kHz may also be possible depending upon the type of glass or covering or the thickness thereof used for the touch pad. Col. 10:60 – Col. 11:27.</p> <p>The `183 Patent discloses “As will be apparent to those skilled in the art, the values of the resistors and capacitors utilized in oscillator 200 may be varied from those disclosed above to provide for different oscillator output frequencies. As discussed above, however, oscillator 200 is preferably constructed so as to output a square wave having a frequency of 50 kHz or greater, and more preferably, of 800 kHz or greater. Col. 14:22-28.</p> <p>The `183 Patent disclosed “The combination of oscillator voltage, frequency and transistor gain bandwidth product that is used will necessarily vary with the cost, safety and reliability requirements of a given application.” Col. 14:65 – Col. 15:1.</p>

YY. New Claim 88

`183 Patent Claim Language	`183 Patent Support
<p>88. The capacitive responsive electronic switching circuit as defined in claim 86, wherein the plurality of Hertz</p>	<p>See Figure 11.</p> <p>The `183 Patent discloses “The touch detection</p>

`183 Patent Claim Language	`183 Patent Support
<p>values comprises Hertz values greater than 100 kHz.</p>	<p>circuit of the present invention features operation at frequencies at or above 50 kHz and preferably at or above 800 kHz to minimize the effects of surface contamination from materials such a [sic] skin oils and water. Col. 5:49-53.</p> <p>The `183 Patent discloses “Conversely, at 100 kHz, the glass impedance drops to approximately 1 MΩ resulting in the impedance of the path to ground for pad 59 being twice that of the touched pad 57. For cases where background noise and temperature drifts are comparatively small, a 100 kHz oscillator frequency would allow a sufficiently low detection threshold to be set to differentiate between the signal changes induced at both pads by a human touch opposite a single pad. At 800 kHz, the impedance of the glass drops to 200 kΩ or lower giving a ratio of a greater than 5 to 1 impedance difference between the paths to ground of the touched pad 57 and adjacent pads 59. In fact, the impedance ratio may exceed 10 to 1, as illustrated in the calculation below. This allows the detection threshold for the touched pad to be set well below that of an adjacent pad resulting in a much lower incidence of inadvertent actuation of adjacent touch pads to that of the touched pad. Ideally, the frequency of operation would be kept at the 800 kHz of the preferred embodiment or even higher. However, as noted earlier, higher frequency operation forces the use of more expensive components and designs. For applications where thermal drift and electronic noise levels are low, operation at or near 100 kHz may be possible. However, at 10 kHz and below, the impedance of the glass becomes much greater than that of likely water bridges between pads resulting in adjacent pads being effected as much by a touch as the touched pad itself. Although the preferred frequency is at or above 100 kHz, and more preferably at or above 800 kHz, it is conceivable that frequencies as low as 50 kHz could be used provided the frequency creates a difference in the impedance</p>

`183 Patent Claim Language	`183 Patent Support
	<p>paths of adjacent pads that is sufficient enough to accurately distinguish between an intended touch and the touch of an adjacent pad. Use of frequencies as low as 50 kHz may also be possible depending upon the type of glass or covering or the thickness thereof used for the touch pad. Col. 10:60 – Col. 11:27.</p> <p>The `183 Patent discloses “As will be apparent to those skilled in the art, the values of the resistors and capacitors utilized in oscillator 200 may be varied from those disclosed above to provide for different oscillator output frequencies. As discussed above, however, oscillator 200 is preferably constructed so as to output a square wave having a frequency of 50 kHz or greater, and more preferably, of 800 kHz or greater. Col. 14:22-28.</p> <p>The `183 Patent disclosed “The combination of oscillator voltage, frequency and transistor gain bandwidth product that is used will necessarily vary with the cost, safety and reliability requirements of a given application.” Col. 14:65 – Col. 15:1.</p>

ZZ. New Claim 89

`183 Patent Claim Language	`183 Patent Support
<p>89. The capacitive responsive electronic switching circuit as defined in claim 86, wherein the plurality of Hertz values comprises Hertz values greater than 800 kHz.</p>	<p>See Fig. 11.</p> <p>The `183 Patent discloses “The touch detection circuit of the present invention features operation at frequencies at or above 50 kHz and preferably at or above 800 kHz to minimize the effects of surface contamination from materials such a [sic] skin oils and water. Col. 5:49-53.</p> <p>The `183 Patent discloses “At 800 kHz, the impedance of the glass drops to 200 kΩ or lower giving a ratio of a greater than 5 to 1 impedance difference between the paths to ground of the touched pad 57 and adjacent pads 59. In fact, the impedance ratio may exceed 10 to 1, as</p>

`183 Patent Claim Language	`183 Patent Support
	<p>illustrated in the calculation below. This allows the detection threshold for the touched pad to be set well below that of an adjacent pad resulting in a much lower incidence of inadvertent actuation of adjacent touch pads to that of the touched pad. Ideally, the frequency of operation would be kept at the 800 kHz of the preferred embodiment or even higher. However, as noted earlier, higher frequency operation forces the use of more expensive components and designs. For applications where thermal drift and electronic noise levels are low, operation at or near 100 kHz may be possible. However, at 10 kHz and below, the impedance of the glass becomes much greater than that of likely water bridges between pads resulting in adjacent pads being effected as much by a touch as the touched pad itself. Although the preferred frequency is at or above 100 kHz, and more preferably at or above 800 kHz, it is conceivable that frequencies as low as 50 kHz could be used provided the frequency creates a difference in the impedance paths of adjacent pads that is sufficient enough to accurately distinguish between an intended touch and the touch of an adjacent pad. Use of frequencies as low as 50 kHz may also be possible depending upon the type of glass or covering or the thickness thereof used for the touch pad. Col. 11:1-27.</p> <p>The `183 Patent discloses “As will be apparent to those skilled in the art, the values of the resistors and capacitors utilized in oscillator 200 may be varied from those disclosed above to provide for different oscillator output frequencies. As discussed above, however, oscillator 200 is preferably constructed so as to output a square wave having a frequency of 50 kHz or greater, and more preferably, of 800 kHz or greater. Col. 14:22-28.</p> <p>The `183 Patent disclosed “The combination of oscillator voltage, frequency and transistor gain bandwidth product that is used will necessarily</p>

`183 Patent Claim Language	`183 Patent Support
	vary with the cost, safety and reliability requirements of a given application.” Col. 14:65 – Col. 15:1.

AAA. New Claim 90

`183 Patent Claim Language	`183 Patent Support
90. The capacitive responsive electronic switching circuit as defined in claim 84, wherein the supply voltage is a battery supply voltage.	The `183 Patent discloses “It will be apparent to those skilled in the art, that various components of voltage regulator 100 may be added or excluded depending upon the source of power available to power the oscillator 200. For example, if the available power is a 110 V AC 60 Hz commercial power line, a transformer may be added to convert the 100 V AC power to 24 V AC. Alternatively, if a DC batter is used, the AC/DC convertor among other components may be eliminated.” Col 13:23-31.

BBB. New Claim 91

`183 Patent Claim Language	`183 Patent Support
91. The capacitive responsive electronic switching circuit as defined in claim 84, wherein the supply voltage is a voltage regulator supply voltage.	<p>Figures 4, 5, 11, and 12.</p> <p>The `183 Patent discloses “The electronic switching circuit includes a voltage regulator 100 including input lines 101 and 102 for receiving a 24 V AC line voltage and a line 103 for grounding the circuit. Voltage regulator 100 converts the received AC voltage to a DC voltage and supplies a regulated 5 V DC power to an oscillator 200 via lines 104 and 105. Voltage regulator also supplies oscillator 200 with 26 V DC power via line 106. The details of voltage regulator 100 are discussed below with reference to FIG. 5.” Col. 11:64 – Col. 12:5; see also Col. 12:50 – Col. 13:31.</p>

CCC. New Claim 92

For ease of analysis, new dependent claim 92 is shown below with pseudo-amendments illustrating the differences between new claim 92 and claim 28 of the `183 Patent following the first reexamination proceeding.

`183 Patent Claim Language	`183 Patent Support
92. The capacitive responsive electronic switching circuit as defined in claim 84, wherein said detector circuit <u>generates is configured to generate</u> said control <u>output</u> signal only when the operator is proximal or touches said second touch terminal within a predetermined time period after the operator is proximal or touches said first touch terminal.	See Claims 27 and 28.

DDD. New Claim 93

For ease of analysis, new dependent claim 93 is shown below with pseudo-amendments illustrating the differences between new claim 93 and claim 36 of the `183 Patent following the first reexamination proceeding.

`183 Patent Claim Language	`183 Patent Support
93. The capacitive responsive electronic switching circuit as defined in claim 84, and further including <u>comprising an indicator for indicating</u> when said the detector circuit determines <u>has determined</u> that the operator is proximal or touches said second touch terminal.	See Claims 32 and 36. The `183 Patent discloses “The microprocessor also allows the use of visual indicators such as LEDs or annunciators such as a bell or tone generator to confirm the actuation of a given touch switch or switches. This is particularly useful in cases where a sequence of actuations is required before an action occurs. The feedback to the operator provided by a visual or audio indicator activated by the microprocessor in response to intermediate touches in a required sequence can minimize time lost and/or frustration on the part of the operator due to failed actuations from partial touches or wrong actuations from touching the wrong pad in a

`183 Patent Claim Language	`183 Patent Support
	<p>given required sequence or combination of touches.” Col. 6:31-42.</p> <p>The `183 Patent discloses “A further option is to provide one or more LEDs 2205 or audible annunciators for visual or audible feedback to the operator. Specifically, in FIG. 19 the LED 2205 will come on when button 2201 has been successfully activated to cue the operator that it is time to move to button 2202. Where required a second LED with a different color than the first (yellow for the first LED and red for the second) can be provided to provide visual confirmation that the second button 2202 has been activated or that the required combination of the two buttons has been activated. Two different audible tone or sound generators could also be used in lieu of the LEDs to provide feedback to the operator.” Col. 23:1-12.</p> <p>The `183 Patent discloses “A red LED 2305 on top of the device shows the completion of the two step turn-on and activation of output relay 2310.” Col. 23:28-30.</p>

EEE. New Claim 94

`183 Patent Claim Language	`183 Patent Support
<p>94. The capacitive responsive electronic switching circuit as defined in claim 84, wherein the detector circuit is configured to inhibit the control output signal unless the operator is proximal or touches said second touch terminal after the operator is proximal or touches said first touch terminal.</p>	<p>See Figures 19, 20A-C; and Claims 28 and 35.</p> <p>The `183 Patent discloses “In another embodiment a method to prevent inadvertent so actuations is to require a multi-step process. Referring to FIG. 19, a device is shown having a first palm button 2201, a second palm button 2202, and an indicator light 2205. Palm button 2201 has to be activated first and then button 2202 has to be activated within a 2 second time window before a desired actuation can occur.” Col. 22:49-55.</p> <p>The `183 Patent discloses “In a variation of the multi-step process, two touch plates within a housing (one vertical and one horizontal) are</p>

`183 Patent Claim Language	`183 Patent Support
	used to provide a two-step turn-on. Referring to FIGS. 20A-C, the first step to actuate the output relay 2310, is initiated when the operator inserts his hands and touches the vertical touch sensor 2301 with the dorsal side of the hands. A yellow LED 2304 on top of the device show the successful completion of the first step. The second step is to flip the hand over and touch the horizontal touch sensor 2302 with the palmar side of the hand. A red LED 2305 on top of the device shows the completion of the two step turn-on and activation of output relay 2310. The flipping action of the hand in the second step causes the forearm muscles to flex, thereby reducing stiffness and fatigue. Also, the hands, and arms can rest on the run bar until the machine cycle is complete. The second step of the two-step turn-on must occur within some predetermined time (for example 2 seconds) after the release of vertical touch sensor or the first step must be repeated.” Col. 23:19-36.

FFF. New Claim 95

For ease of analysis, new independent claim 95 is shown below with pseudo-amendments illustrating the differences between new claim 95 and claim 27 of the `183 Patent following the first reexamination proceeding.

`183 Patent Claim Language	`183 Patent Support
95. A capacitive responsive electronic switching circuit for a controlled keypad device comprising:	See Claim 27.
an oscillator providing a periodic output signal having a predefined frequency;	See Claim 27.
a microcontroller using the periodic output signal from the oscillator, the microcontroller selectively providing signal output frequencies, <u>wherein a signal output frequency is selectively provided to each row of a closely spaced</u>	See Figures 4, 5, 11; and Claims 8, 12, 16, 27 and 37. The `183 Patent discloses “The touch detection circuit of the present invention features operation at frequencies at or above 50 kHz and preferably

`183 Patent Claim Language	`183 Patent Support
<p>array of input touch terminals of a keypad, the input touch terminals comprising first and second input touch terminals, <u>and wherein a peak voltage of the signal output frequencies is greater than a supply voltage;</u></p>	<p>at or above 800 kHz to minimize the effects of surface contamination from materials such a [sic] skin oils and water. It also offers improvements in detection sensitivity that allow close control of the degree of proximity (ideally very close proximity) that is required for actuation and to enable employment of a multiplicity of small sized touch terminals in a physically close array such as a keyboard.” Col. 5:49-57.</p> <p>The `183 Patent discloses “In a first preferred embodiment the circuit offers enhanced detection sensitivity to allow reliable operation with small (finger size) touch pads.” Col. 6:1-3.</p> <p>The `183 Patent discloses “Although the preferred frequency is at or above 100 kHz, and more preferably at or above 800 kHz, it is conceivable that frequencies as low as 50 kHz could be used provided the frequency creates a difference in the impedance paths of adjacent pads that is sufficient enough to accurately distinguish between an intended touch and the touch of an adjacent pad. Use of frequencies as low as 50 kHz may also be possible depending upon the type of glass or covering or the thickness thereof used for the touch pad.” Col. 11:19-27.</p> <p>The `183 Patent discloses “Having provided a basis for the use of higher frequencies, the basic construction of the electronic switching circuit constructed in accordance with a first embodiment of the present invention is now described with reference to FIG. 4. The electronic switching circuit includes a voltage regulator 100 including input lines 101 and 102 for receiving a 24 V AC line voltage and a line 103 for grounding the circuit. Voltage regulator 100 converts the received AC voltage to a DC voltage and supplies a regulated 5 V DC power to an oscillator 200 via lines 104 and 105. Voltage regulator also supplies oscillator 200</p>

`183 Patent Claim Language	`183 Patent Support
	<p>with 26 V DC power via line 106. The details of voltage regulator 100 are discussed below with reference to FIG. 5.</p> <p>Upon being powered by voltage regulator 100, oscillator 200 generates a square wave with a frequency of 50 kHz, and preferably greater than 800 kHz, and having an amplitude of 26 V peak. The square wave generated by oscillator 200 is supplied via line 201 to a floating common generator 300, a touch pad shield plate 460, a touch circuit 400, and a microcontroller 500. Oscillator 200 is described below with reference to FIG. 6.</p> <p>Floating common generator 300 receives the 26 V peak square wave from oscillator 200 and outputs a regulated floating common that is 5 volts below the square wave output from oscillator 200 and has the same phase and frequency as the received square wave. This floating common output is supplied to touch circuit 400 and microcontroller 500 via line 301 such that the output square wave from oscillator 200 and floating common output from floating common generator 300 provide power to touch circuit 400 and microcontroller 500. Details of floating common generator 300 are discussed below with reference to FIG. 7.</p> <p>Touch circuit 400 senses capacitance from a touch pad 450 via line 451 and outputs a signal to microcontroller 500 via line 401 upon detecting a capacitance to ground at touch pad 450 that exceeds a threshold value. The details of touch circuit 400 are described below with reference to FIG. 8.</p> <p>Upon receiving an indication from touch circuit 400 that a sufficient capacitance to ground (typically at least 20 pF) is present at touch pad 450, microcontroller 500 outputs a signal to a load-controlling microcontroller 600 via line 501, which is preferably a two way optical coupling bus.” Col. 11:60 – 12:33.</p> <p>The `183 Patent discloses “A preferred circuit for implementing a voltage regulator 100 is</p>

`183 Patent Claim Language	`183 Patent Support
	<p>shown in FIG. 5. Voltage regulator 100 preferably includes an AC/DC convertor 110 for generating 29 V to 36 V unregulated DC on line 119. This unregulated DC power is supplied to a 5 V DC regulator 120 and to a 26 V DC regulator 130. AC/DC convertor 110 includes diodes 112, 114, 116, and 118, which rectify the supplied 24 V AC power provided on power lines 101 and 102.” Col. 12:50-57; see also Col. 12:57 – Col. 13:31.</p> <p>The `183 Patent discloses “As will be apparent to those skilled in the art, the values of the resistors and capacitors utilized in oscillator 200 may be varied from those disclosed above to provide for different oscillator output frequencies.” Col. 14:22-25.</p> <p>The `183 Patent discloses “The oscillator circuitry shown in FIG. 6 is very stable over the temperature range of -40° C. to 105° C. The output of the touch switch circuitry drops at a rate of approximately 40 mV/°C. when temperature falls below 0° C. If application requires operation at low temperatures (-40° C.), the following three methods may be used to increase the output of the switch: increase the oscillator’s regulated supply voltage, increase the resistance of resistor 416, and use a higher gain transistor 410. All of these methods would increase sensitivity at high temperatures.” Col. 16:33-41.</p> <p>The `183 Patent discloses “A multiple touch pad circuit constructed in accordance with the second embodiment is shown in FIG. 11. In the second embodiment of FIG. 11, components similar to those in the first embodiment in FIG. 4 are designated with the same references numerals and will not be discussed in detail. The multiple touch pad circuit is a variation of the first embodiment in that it includes an array of touch circuits designated as 900₁ through 900_{nm}, which, as shown, include both the touch</p>

`183 Patent Claim Language	`183 Patent Support
	<p>circuit 400 shown in FIGS. 4 and 8 and the input touch terminal pad 451 (FIG. 4). Microcontroller 500 selects each row of the touch circuits 900₁ to 900_{nm} by providing the signal from oscillator 200 to selected rows of touch circuits. In this manner, microcontroller 500 can sequentially activate the touch circuit rows and associate the received inputs from the columns of the array with the activated touch circuit(s). To keep the path length 451 between the touch pad 450 and the base to the detection transistor 410 to a minimum, the detection circuits 900 are physically located directly beneath the touch pads. To simplify assembly, a flexible circuit board such as vended by Sheldahl, Inc. or Circuit Etching Technics, Inc. can be used for this purpose. Ideally, the printed circuit will be fixed directly against the surface (typically glass) bearing the conductive touch pads to eliminate air gaps and the need for conductive foam pads and spring contacts which were used to fill air gaps.” Col. 18:34-59.</p>
<p>the first and second input touch terminals defining areas for an operator to provide an input by proximity and touch; and</p>	<p>See Claim 27.</p>
<p>a detector circuit coupled to said oscillator for receiving said periodic output signal from said oscillator, and coupled to said first and second touch terminals, said detector circuit being responsive to signals from said oscillator via said microcontroller and a presence of an operator's body capacitance to ground coupled to said first and second touch terminals when proximal or touched by the operator to provide a control output signal for actuation of the controlled keypad device, said detector circuit being configured to generate said control output signal when the operator is proximal or touches said second touch terminal after the operator is proximal or touches said</p>	<p>See Claim 27.</p>

`183 Patent Claim Language	`183 Patent Support
first touch terminal.	

GGG. New Claim 96

`183 Patent Claim Language	`183 Patent Support
<p>96. The capacitive responsive electronic switching circuit as defined in claim 95, wherein each signal output frequency selectively provided to each row of the closely spaced array of input touch terminals of the keypad has a same Hertz value.</p>	<p>See Figure 11.</p> <p>The `183 Patent discloses “The touch detection circuit of the present invention features operation at frequencies at or above 50 kHz and preferably at or above 800 kHz to minimize the effects of surface contamination from materials such a [sic] skin oils and water. Col. 5:49-53.</p> <p>The `183 Patent discloses “Conversely, at 100 kHz, the glass impedance drops to approximately 1 MΩ resulting in the impedance of the path to ground for pad 59 being twice that of the touched pad 57. For cases where background noise and temperature drifts are comparatively small, a 100 kHz oscillator frequency would allow a sufficiently low detection threshold to be set to differentiate between the signal changes induced at both pads by a human touch opposite a single pad. At 800 kHz, the impedance of the glass drops to 200 kΩ or lower giving a ratio of a greater than 5 to 1 impedance difference between the paths to ground of the touched pad 57 and adjacent pads 59. In fact, the impedance ratio may exceed 10 to 1, as illustrated in the calculation below. This allows the detection threshold for the touched pad to be set well below that of an adjacent pad resulting in a much lower incidence of inadvertent actuation of adjacent touch pads to that of the touched pad. Ideally, the frequency of operation would be kept at the 800 kHz of the preferred embodiment or even higher. However, as noted earlier, higher frequency operation forces the use of more expensive components and designs. For applications where thermal drift and electronic noise levels are low, operation at or near 100 kHz may be possible. However, at 10 kHz and below, the impedance of the glass</p>

`183 Patent Claim Language	`183 Patent Support
	<p>becomes much greater than that of likely water bridges between pads resulting in adjacent pads being effected as much by a touch as the touched pad itself. Although the preferred frequency is at or above 100 kHz, and more preferably at or above 800 kHz, it is conceivable that frequencies as low as 50 kHz could be used provided the frequency creates a difference in the impedance paths of adjacent pads that is sufficient enough to accurately distinguish between an intended touch and the touch of an adjacent pad. Use of frequencies as low as 50 kHz may also be possible depending upon the type of glass or covering or the thickness thereof used for the touch pad. Col. 10:60 – Col. 11:27.</p> <p>The `183 Patent discloses “As will be apparent to those skilled in the art, the values of the resistors and capacitors utilized in oscillator 200 may be varied from those disclosed above to provide for different oscillator output frequencies. As discussed above, however, oscillator 200 is preferably constructed so as to output a square wave having a frequency of 50 kHz or greater, and more preferably, of 800 kHz or greater. Col. 14:22-28.</p> <p>The `183 Patent disclosed “The combination of oscillator voltage, frequency and transistor gain bandwidth product that is used will necessarily vary with the cost, safety and reliability requirements of a given application.” Col. 14:65 – Col. 15:1.</p>

HHH. New Claim 97

`183 Patent Claim Language	`183 Patent Support
<p>97. The capacitive responsive electronic switching circuit as defined in claim 95, wherein each signal output frequency selectively provided to each row of the closely spaced array of input touch terminals of the keypad is selected</p>	<p>See Figure 11.</p> <p>The `183 Patent discloses “The touch detection circuit of the present invention features operation at frequencies at or above 50 kHz and preferably at or above 800 kHz to minimize the effects of surface contamination from materials such a</p>

`183 Patent Claim Language	`183 Patent Support
<p>from a plurality of Hertz values.</p>	<p>[sic] skin oils and water. Col. 5:49-53.</p> <p>The `183 Patent discloses “Conversely, at 100 kHz, the glass impedance drops to approximately 1 MΩ resulting in the impedance of the path to ground for pad 59 being twice that of the touched pad 57. For cases where background noise and temperature drifts are comparatively small, a 100 kHz oscillator frequency would allow a sufficiently low detection threshold to be set to differentiate between the signal changes induced at both pads by a human touch opposite a single pad. At 800 kHz, the impedance of the glass drops to 200 kΩ or lower giving a ratio of a greater than 5 to 1 impedance difference between the paths to ground of the touched pad 57 and adjacent pads 59. In fact, the impedance ratio may exceed 10 to 1, as illustrated in the calculation below. This allows the detection threshold for the touched pad to be set well below that of an adjacent pad resulting in a much lower incidence of inadvertent actuation of adjacent touch pads to that of the touched pad. Ideally, the frequency of operation would be kept at the 800 kHz of the preferred embodiment or even higher. However, as noted earlier, higher frequency operation forces the use of more expensive components and designs. For applications where thermal drift and electronic noise levels are low, operation at or near 100 kHz may be possible. However, at 10 kHz and below, the impedance of the glass becomes much greater than that of likely water bridges between pads resulting in adjacent pads being effected as much by a touch as the touched pad itself. Although the preferred frequency is at or above 100 kHz, and more preferably at or above 800 kHz, it is conceivable that frequencies as low as 50 kHz could be used provided the frequency creates a difference in the impedance paths of adjacent pads that is sufficient enough to accurately distinguish between an intended touch and the touch of an adjacent pad. Use of frequencies as low as 50 kHz may also be</p>

`183 Patent Claim Language	`183 Patent Support
	<p>possible depending upon the type of glass or covering or the thickness thereof used for the touch pad. Col. 10:60 – Col. 11:27.</p> <p>The `183 Patent discloses “As will be apparent to those skilled in the art, the values of the resistors and capacitors utilized in oscillator 200 may be varied from those disclosed above to provide for different oscillator output frequencies. As discussed above, however, oscillator 200 is preferably constructed so as to output a square wave having a frequency of 50 kHz or greater, and more preferably, of 800 kHz or greater. Col. 14:22-28.</p> <p>The `183 Patent disclosed “The combination of oscillator voltage, frequency and transistor gain bandwidth product that is used will necessarily vary with the cost, safety and reliability requirements of a given application.” Col. 14:65 – Col. 15:1.</p>

III. New Claim 98

`183 Patent Claim Language	`183 Patent Support
<p>98. The capacitive responsive electronic switching circuit as defined in claim 97, wherein the plurality of Hertz values comprises Hertz values greater than 50 kHz.</p>	<p>See Figure 11.</p> <p>The `183 Patent discloses “The touch detection circuit of the present invention features operation at frequencies at or above 50 kHz and preferably at or above 800 kHz to minimize the effects of surface contamination from materials such a [sic] skin oils and water. Col. 5:49-53.</p> <p>The `183 Patent discloses “Conversely, at 100 kHz, the glass impedance drops to approximately 1 MΩ resulting in the impedance of the path to ground for pad 59 being twice that of the touched pad 57. For cases where background noise and temperature drifts are comparatively small, a 100 kHz oscillator frequency would allow a sufficiently low detection threshold to be set to differentiate between the signal changes induced at both pads</p>

`183 Patent Claim Language	`183 Patent Support
	<p>by a human touch opposite a single pad. At 800 kHz, the impedance of the glass drops to 200 kΩ or lower giving a ratio of a greater than 5 to 1 impedance difference between the paths to ground of the touched pad 57 and adjacent pads 59. In fact, the impedance ratio may exceed 10 to 1, as illustrated in the calculation below. This allows the detection threshold for the touched pad to be set well below that of an adjacent pad resulting in a much lower incidence of inadvertent actuation of adjacent touch pads to that of the touched pad. Ideally, the frequency of operation would be kept at the 800 kHz of the preferred embodiment or even higher. However, as noted earlier, higher frequency operation forces the use of more expensive components and designs. For applications where thermal drift and electronic noise levels are low, operation at or near 100 kHz may be possible. However, at 10 kHz and below, the impedance of the glass becomes much greater than that of likely water bridges between pads resulting in adjacent pads being effected as much by a touch as the touched pad itself. Although the preferred frequency is at or above 100 kHz, and more preferably at or above 800 kHz, it is conceivable that frequencies as low as 50 kHz could be used provided the frequency creates a difference in the impedance paths of adjacent pads that is sufficient enough to accurately distinguish between an intended touch and the touch of an adjacent pad. Use of frequencies as low as 50 kHz may also be possible depending upon the type of glass or covering or the thickness thereof used for the touch pad. Col. 10:60 – Col. 11:27.</p> <p>The `183 Patent discloses “As will be apparent to those skilled in the art, the values of the resistors and capacitors utilized in oscillator 200 may be varied from those disclosed above to provide for different oscillator output frequencies. As discussed above, however, oscillator 200 is preferably constructed so as to output a square wave having a frequency of 50</p>

`183 Patent Claim Language	`183 Patent Support
	<p>kHz or greater, and more preferably, of 800 kHz or greater. Col. 14:22-28.</p> <p>The `183 Patent disclosed “The combination of oscillator voltage, frequency and transistor gain bandwidth product that is used will necessarily vary with the cost, safety and reliability requirements of a given application.” Col. 14:65 – Col. 15:1.</p>

JJJ. New Claim 99

`183 Patent Claim Language	`183 Patent Support
<p>99. The capacitive responsive electronic switching circuit as defined in claim 97, wherein the plurality of Hertz values comprises Hertz values greater than 100 kHz.</p>	<p>See Figure 11.</p> <p>The `183 Patent discloses “The touch detection circuit of the present invention features operation at frequencies at or above 50 kHz and preferably at or above 800 kHz to minimize the effects of surface contamination from materials such a [sic] skin oils and water. Col. 5:49-53.</p> <p>The `183 Patent discloses “Conversely, at 100 kHz, the glass impedance drops to approximately 1 MΩ resulting in the impedance of the path to ground for pad 59 being twice that of the touched pad 57. For cases where background noise and temperature drifts are comparatively small, a 100 kHz oscillator frequency would allow a sufficiently low detection threshold to be set to differentiate between the signal changes induced at both pads by a human touch opposite a single pad. At 800 kHz, the impedance of the glass drops to 200 kΩ or lower giving a ratio of a greater than 5 to 1 impedance difference between the paths to ground of the touched pad 57 and adjacent pads 59. In fact, the impedance ratio may exceed 10 to 1, as illustrated in the calculation below. This allows the detection threshold for the touched pad to be set well below that of an adjacent pad resulting in a much lower incidence of inadvertent actuation of adjacent touch pads to that of the touched pad. Ideally, the frequency of</p>

`183 Patent Claim Language	`183 Patent Support
	<p>operation would be kept at the 800 kHz of the preferred embodiment or even higher. However, as noted earlier, higher frequency operation forces the use of more expensive components and designs. For applications where thermal drift and electronic noise levels are low, operation at or near 100 kHz may be possible. However, at 10 kHz and below, the impedance of the glass becomes much greater than that of likely water bridges between pads resulting in adjacent pads being effected as much by a touch as the touched pad itself. Although the preferred frequency is at or above 100 kHz, and more preferably at or above 800 kHz, it is conceivable that frequencies as low as 50 kHz could be used provided the frequency creates a difference in the impedance paths of adjacent pads that is sufficient enough to accurately distinguish between an intended touch and the touch of an adjacent pad. Use of frequencies as low as 50 kHz may also be possible depending upon the type of glass or covering or the thickness thereof used for the touch pad. Col. 10:60 – Col. 11:27.</p> <p>The `183 Patent discloses “As will be apparent to those skilled in the art, the values of the resistors and capacitors utilized in oscillator 200 may be varied from those disclosed above to provide for different oscillator output frequencies. As discussed above, however, oscillator 200 is preferably constructed so as to output a square wave having a frequency of 50 kHz or greater, and more preferably, of 800 kHz or greater. Col. 14:22-28.</p> <p>The `183 Patent disclosed “The combination of oscillator voltage, frequency and transistor gain bandwidth product that is used will necessarily vary with the cost, safety and reliability requirements of a given application.” Col. 14:65 – Col. 15:1.</p>

KKK. New Claim 100

`183 Patent Claim Language	`183 Patent Support
<p>100. The capacitive responsive electronic switching circuit as defined in claim 97, wherein the plurality of Hertz values comprises Hertz values greater than 800 kHz.</p>	<p>See Fig. 11.</p> <p>The `183 Patent discloses “The touch detection circuit of the present invention features operation at frequencies at or above 50 kHz and preferably at or above 800 kHz to minimize the effects of surface contamination from materials such a [sic] skin oils and water. Col. 5:49-53.</p> <p>The `183 Patent discloses “At 800 kHz, the impedance of the glass drops to 200 kΩ or lower giving a ratio of a greater than 5 to 1 impedance difference between the paths to ground of the touched pad 57 and adjacent pads 59. In fact, the impedance ratio may exceed 10 to 1, as illustrated in the calculation below. This allows the detection threshold for the touched pad to be set well below that of an adjacent pad resulting in a much lower incidence of inadvertent actuation of adjacent touch pads to that of the touched pad. Ideally, the frequency of operation would be kept at the 800 kHz of the preferred embodiment or even higher. However, as noted earlier, higher frequency operation forces the use of more expensive components and designs. For applications where thermal drift and electronic noise levels are low, operation at or near 100 kHz may be possible. However, at 10 kHz and below, the impedance of the glass becomes much greater than that of likely water bridges between pads resulting in adjacent pads being effected as much by a touch as the touched pad itself. Although the preferred frequency is at or above 100 kHz, and more preferably at or above 800 kHz, it is conceivable that frequencies as low as 50 kHz could be used provided the frequency creates a difference in the impedance paths of adjacent pads that is sufficient enough to accurately distinguish between an intended touch and the touch of an adjacent pad. Use of frequencies as low as 50 kHz may also be possible depending upon the type of glass or covering or the thickness thereof used for the</p>

`183 Patent Claim Language	`183 Patent Support
	<p>touch pad. Col. 11:1-27.</p> <p>The `183 Patent discloses “As will be apparent to those skilled in the art, the values of the resistors and capacitors utilized in oscillator 200 may be varied from those disclosed above to provide for different oscillator output frequencies. As discussed above, however, oscillator 200 is preferably constructed so as to output a square wave having a frequency of 50 kHz or greater, and more preferably, of 800 kHz or greater. Col. 14:22-28.</p> <p>The `183 Patent disclosed “The combination of oscillator voltage, frequency and transistor gain bandwidth product that is used will necessarily vary with the cost, safety and reliability requirements of a given application.” Col. 14:65 – Col. 15:1.</p>

LLL. New Claim 101

`183 Patent Claim Language	`183 Patent Support
<p>101. The capacitive responsive electronic switching circuit as defined in claim 95, wherein the supply voltage is a battery supply voltage.</p>	<p>The `183 Patent discloses “It will be apparent to those skilled in the art, that various components of voltage regulator 100 may be added or excluded depending upon the source of power available to power the oscillator 200. For example, if the available power is a 110 V AC 60 Hz commercial power line, a transformer may be added to convert the 100 V AC power to 24 V AC. Alternatively, if a DC batter is used, the AC/DC convertor among other components may be eliminated.” Col 13:23-31.</p>

MMM. New Claim 102

`183 Patent Claim Language	`183 Patent Support
<p>102. The capacitive responsive electronic switching circuit as defined in claim 95, wherein the supply voltage is a</p>	<p>Figures 4, 5, 11, and 12.</p> <p>The `183 Patent discloses “The electronic switching circuit includes a voltage regulator 100 including input lines 101 and 102 for</p>

`183 Patent Claim Language	`183 Patent Support
voltage regulator supply voltage.	receiving a 24 V AC line voltage and a line 103 for grounding the circuit. Voltage regulator 100 converts the received AC voltage to a DC voltage and supplies a regulated 5 V DC power to an oscillator 200 via lines 104 and 105. Voltage regulator also supplies oscillator 200 with 26 V DC power via line 106. The details of voltage regulator 100 are discussed below with reference to FIG. 5.” Col. 11:64 – Col. 12:5; see also Col. 12:50 – Col. 13:31.

NNN. New Claim 103

For ease of analysis, new dependent claim 103 is shown below with pseudo-amendments illustrating the differences between new claim 103 and claim 28 of the `183 Patent following the first reexamination proceeding.

`183 Patent Claim Language	`183 Patent Support
103. The capacitive responsive electronic switching circuit as defined in claim 95, wherein said detector circuit generates <u>is configured to generate</u> said control output signal only when the operator is proximal or touches said second touch terminal within a predetermined time period after the operator is proximal or touches said first touch terminal.	See Claims 27 and 28.

OOO. New Claim 104

For ease of analysis, new dependent claim 104 is shown below with pseudo-amendments illustrating the differences between new claim 104 and claim 36 of the `183 Patent following the first reexamination proceeding.

`183 Patent Claim Language	`183 Patent Support
104. The capacitive responsive electronic switching circuit as defined in claim 95, and further including	See Claims 32 and 36. The `183 Patent discloses “The microprocessor

`183 Patent Claim Language	`183 Patent Support
<p><u>comprising</u> an indicator for indicating when said the detector circuit determines <u>has determined</u> that the operator is proximal or touches said second touch terminal.</p>	<p>also allows the use of visual indicators such as LEDs or annunciators such as a bell or tone generator to confirm the actuation of a given touch switch or switches. This is particularly useful in cases where a sequence of actuations is required before an action occurs. The feedback to the operator provided by a visual or audio indicator activated by the microprocessor in response to intermediate touches in a required sequence can minimize time lost and/or frustration on the part of the operator due to failed actuations from partial touches or wrong actuations from touching the wrong pad in a given required sequence or combination of touches.” Col. 6:31-42.</p> <p>The `183 Patent discloses “A further option is to provide one or more LEDs 2205 or audible annunciators for visual or audible feedback to the operator. Specifically, in FIG. 19 the LED 2205 will come on when button 2201 has been successfully activated to cue the operator that it is time to move to button 2202. Where required a second LED with a different color than the first (yellow for the first LED and red for the second) can be provided to provide visual confirmation that the second button 2202 has been activated or that the required combination of the two buttons has been activated. Two different audible tone or sound generators could also be used in lieu of the LEDs to provide feedback to the operator.” Col. 23:1-12.</p> <p>The `183 Patent discloses “A red LED 2305 on top of the device shows the completion of the two step turn-on and activation of output relay 2310.” Col. 23:28-30.</p>

PPP. New Claim 105

`183 Patent Claim Language	`183 Patent Support
<p>105. The capacitive responsive electronic switching circuit as defined in claim 95, wherein the detector circuit is</p>	<p>See Figures 19, 20A-C; and Claims 28 and 35.</p> <p>The `183 Patent discloses “In another</p>

`183 Patent Claim Language	`183 Patent Support
<p>configured to inhibit the control output signal unless the operator is proximal or touches said second touch terminal after the operator is proximal or touches said first touch terminal.</p>	<p>embodiment a method to prevent inadvertent so actuations is to require a multi-step process. Referring to FIG. 19, a device is shown having a first palm button 2201, a second palm button 2202, and an indicator light 2205. Palm button 2201 has to be activated first and then button 2202 has to be activated within a 2 second time window before a desired actuation can occur.” Col. 22:49-55.</p> <p>The `183 Patent discloses “In a variation of the multi-step process, two touch plates within a housing (one vertical and one horizontal) are used to provide a two-step turn-on. Referring to FIGS. 20A-C, the first step to actuate the output relay 2310, is initiated when the operator inserts his hands and touches the vertical touch sensor 2301 with the dorsal side of the hands. A yellow LED 2304 on top of the device show the successful completion of the first step. The second step is to flip the hand over and touch the horizontal touch sensor 2302 with the palmar side of the hand. A red LED 2305 on top of the device shows the completion of the two step turn-on and activation of output relay 2310. The flipping action of the hand in the second step causes the forearm muscles to flex, thereby reducing stiffness and fatigue. Also, the hands, and arms can rest on the run bar until the machine cycle is complete. The second step of the two-step turn-on must occur within some predetermined time (for example 2 seconds) after the release of vertical touch sensor or the first step must be repeated.” Col. 23:19-36.</p>

V. **CONCLUSION**

In view of the above, the Patent Owner submits that the claims are in condition for allowance. The present amendment neither enlarges the scope of the claims of the patent nor introduces new matter. If the Examiner should have any questions, please contact the Patent Owner's Attorney, Brian A. Carlson, at 972-732-1001. The Commissioner is hereby authorized to charge any fees due in connection with this filing, or credit any overpayment, to Deposit Account No. 50-1065.

Respectfully submitted,

December 24, 2013
Date

/Brian A. Carlson/
Brian A. Carlson
Reg. No. 37,793

Slater & Matsil, L.L.P.
17950 Preston Rd.
Suite 1000
Dallas, TX 75252
972-732-1001
972-732-9218 (fax)



US005796183A

United States Patent [19]
Hourmand

[11] **Patent Number:** **5,796,183**
[45] **Date of Patent:** **Aug. 18, 1998**

[54] **CAPACITIVE RESPONSIVE ELECTRONIC SWITCHING CIRCUIT**

[75] Inventor: **Byron Hourmand**, Hersey, Mich.

[73] Assignee: **Nartron Corporation**, Reed City, Mich.

[21] Appl. No.: **601,268**

[22] Filed: **Jan. 31, 1996**

[51] **Int. Cl.⁶** **H01H 35/00**

[52] **U.S. Cl.** **307/116; 361/181; 307/125; 307/139**

[58] **Field of Search** **307/112, 113, 307/116, 125, 139, 140, 157; 361/181**

[56] **References Cited**

U.S. PATENT DOCUMENTS

3,549,909	12/1970	Adelson et al. .	
3,641,410	2/1972	Vogelsberg .	
3,651,391	3/1972	Vogelsberg .	
3,666,988	5/1972	Bellis .	
3,798,370	3/1974	Hurst .	
3,879,618	4/1975	Larson	307/116
3,899,713	8/1975	Barkan et al. .	
3,911,215	10/1975	Hurst et al. .	
3,919,596	11/1975	Bellis .	
3,965,465	6/1976	Alexander .	
3,984,757	10/1976	Gott et al. .	
4,016,453	4/1977	Moennig .	
4,031,408	6/1977	Holz .	
4,071,689	1/1978	Talmage et al. .	
4,101,805	7/1978	Stone .	
4,119,864	10/1978	Petrizio .	
4,152,629	5/1979	Raupp .	
4,159,473	6/1979	Senk .	
4,210,822	7/1980	Wern .	
4,211,959	7/1980	Deavenport et al. .	
4,213,061	7/1980	Conner .	
4,220,815	9/1980	Gibson et al. .	
4,237,421	12/1980	Waldron .	
4,246,533	1/1981	Chiang .	
4,257,117	3/1981	Besson .	
4,264,831	4/1981	Wern .	
4,289,972	9/1981	Wern .	
4,289,980	9/1981	McLaughlin .	

4,308,443	12/1981	Tucker et al. .	
4,323,829	4/1982	Witney et al. .	
4,352,141	9/1982	Kent	363/181
4,360,737	11/1982	Leopold .	
4,374,381	2/1983	Ng et al. .	
4,476,463	10/1984	Ng et al. .	
4,503,294	3/1985	Matsumaru	200/5 A
4,731,548	3/1988	Ingraham .	
4,758,735	7/1988	Ingraham .	
4,831,279	5/1989	Ingraham .	
4,910,504	3/1990	Eriksson .	
4,939,382	7/1990	Gruodis .	
4,942,631	7/1990	Rosa	4/623
5,012,124	4/1991	Hollaway .	
5,066,898	11/1991	Miller et al. .	
5,087,825	2/1992	Ingraham .	
5,208,516	5/1993	Saidian .	
5,233,231	8/1993	Wieth et al. .	
5,235,217	8/1993	Kirton	307/326
5,386,219	1/1995	Greanias et al. .	
5,453,644	9/1995	Yap et al. .	
5,572,205	11/1996	Caldwell et al.	341/33

Primary Examiner—William M. Shoop, Jr.
Assistant Examiner—Jonathan Kaplan
Attorney, Agent, or Firm—Price, Heneveld, Cooper, DeWitt & Litton

[57] **ABSTRACT**

A capacitive responsive electronic switching circuit comprises an oscillator providing a periodic output signal having a frequency of 50 kHz or greater, an input touch terminal defining an area for an operator provide an input by proximity and touch, and a detector circuit coupled to the oscillator for receiving the periodic output signal from the oscillator, and coupled to the input touch terminal. The detector circuit being responsive to signals from the oscillator and the presence of an operator's body capacitance to ground coupled to the touch terminal when in proximity or touched by an operator to provide a control output signal. Preferably, the oscillator provides a periodic output signal having a frequency of 800 kHz or greater. An array of touch terminals may be provided in close proximity due to the reduction in crosstalk that may result from contaminants by utilizing an oscillator outputting a signal having a frequency of 50 kHz or greater.

32 Claims, 13 Drawing Sheets

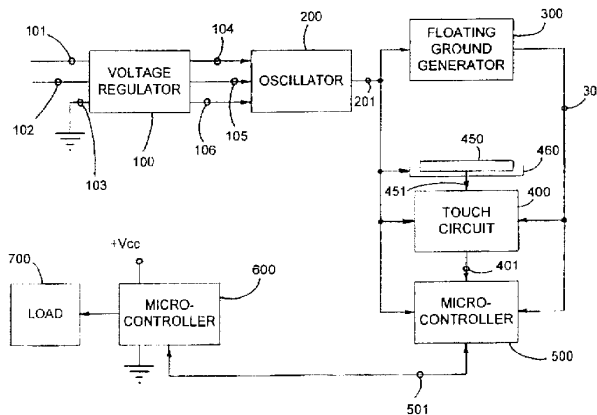

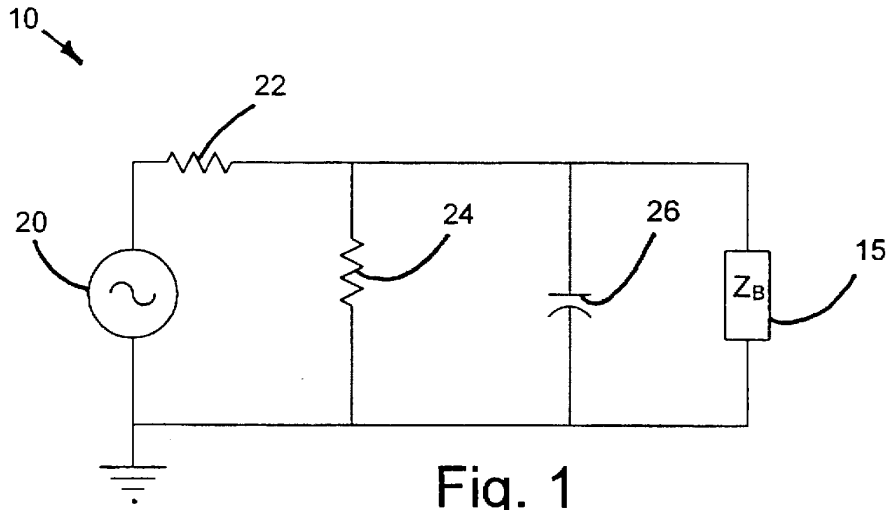

Fig. 1

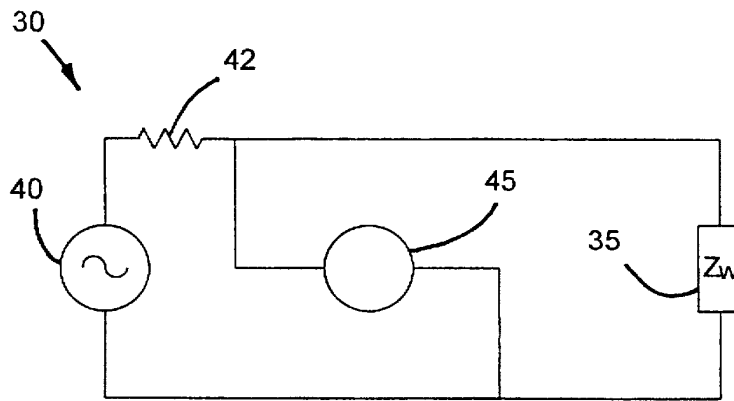

Fig. 2

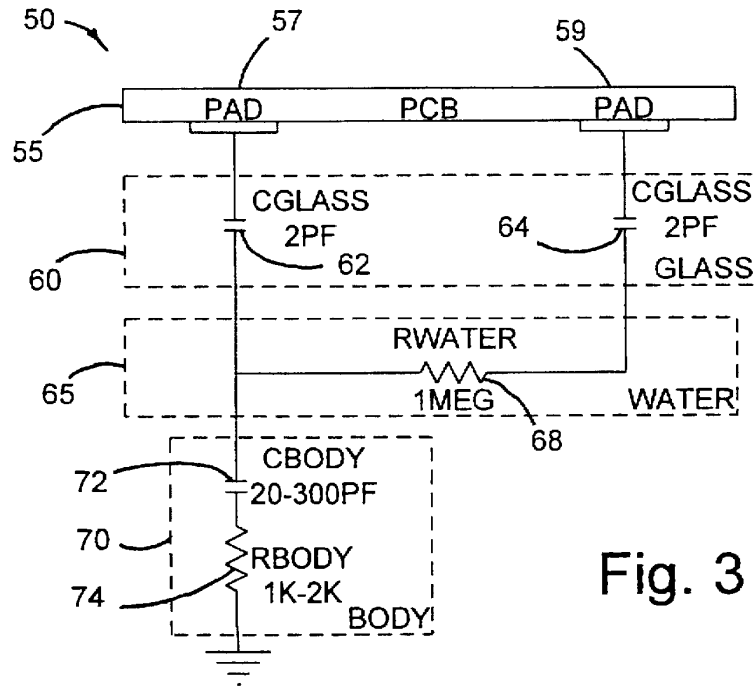

Fig. 3

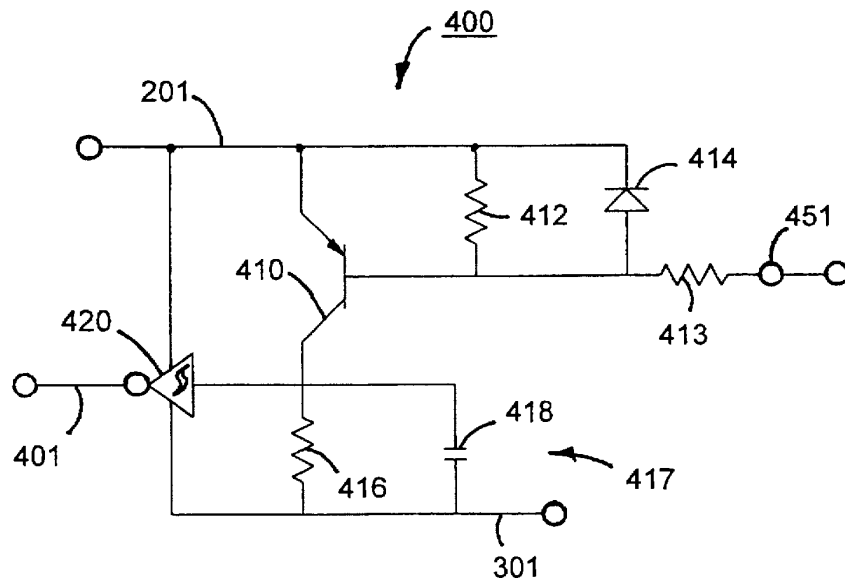

Fig. 8

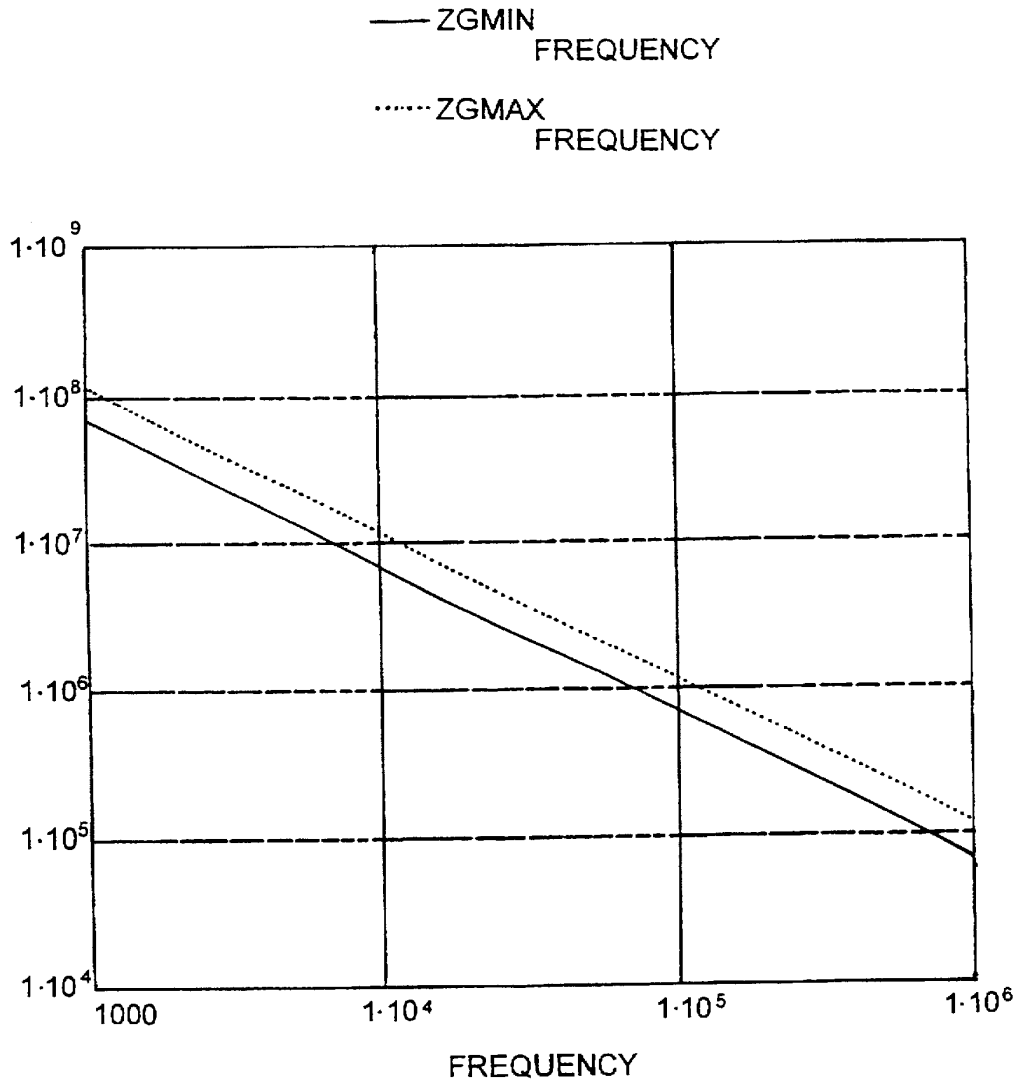

Fig. 3A

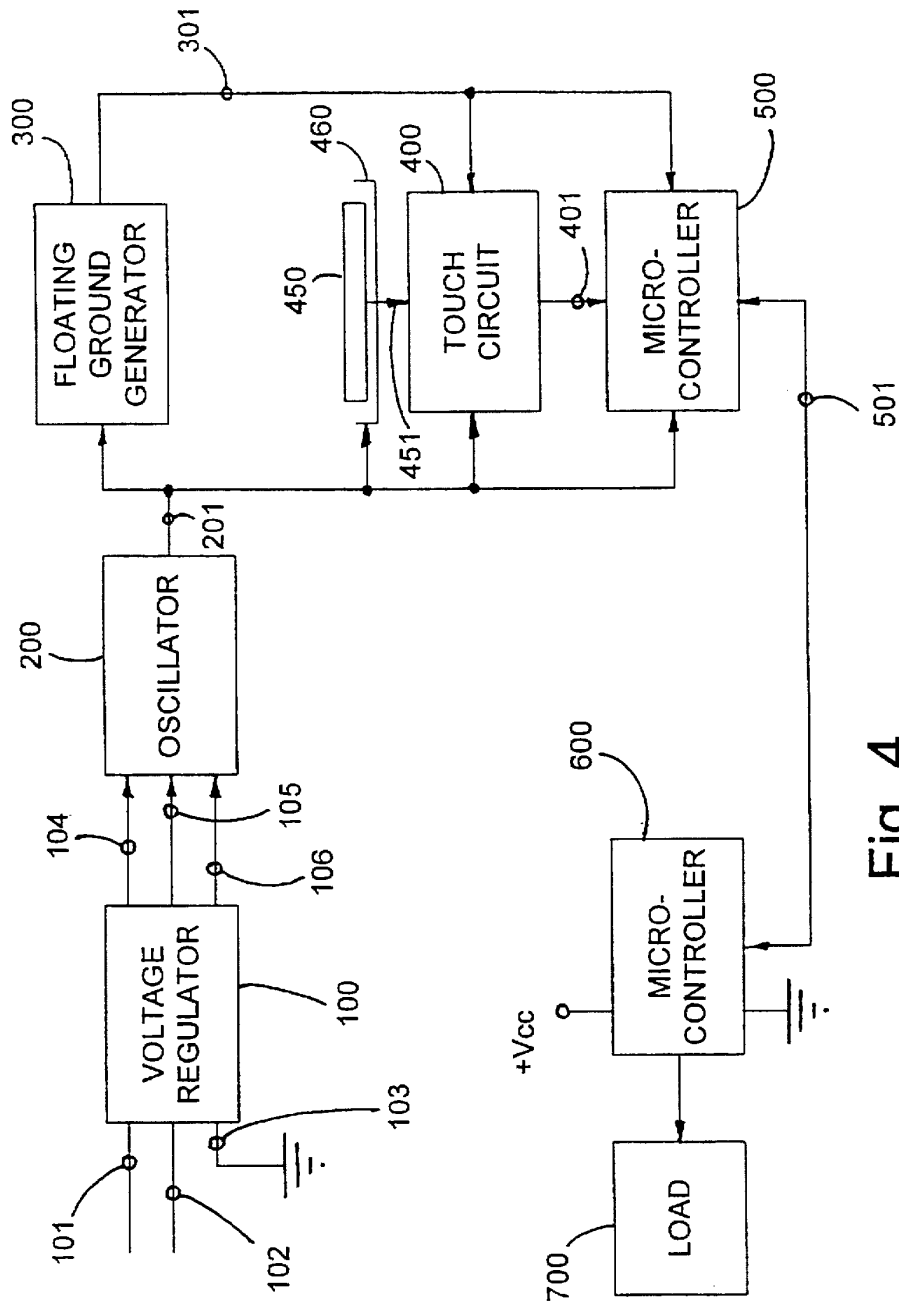
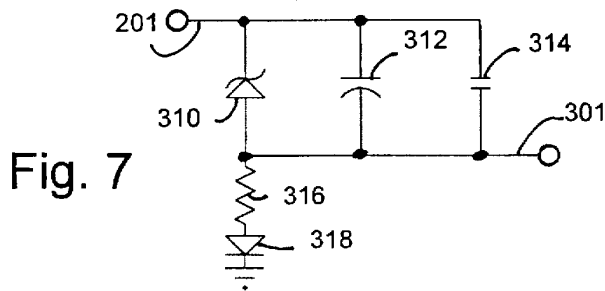
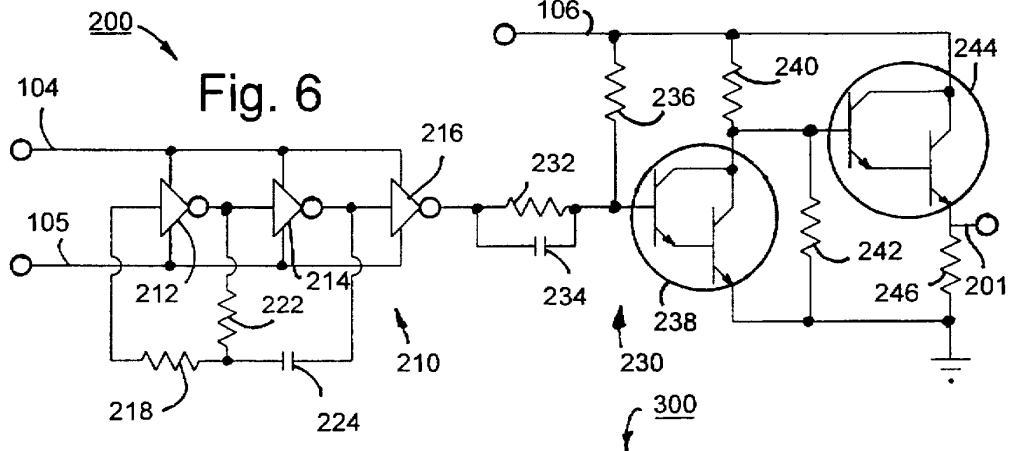
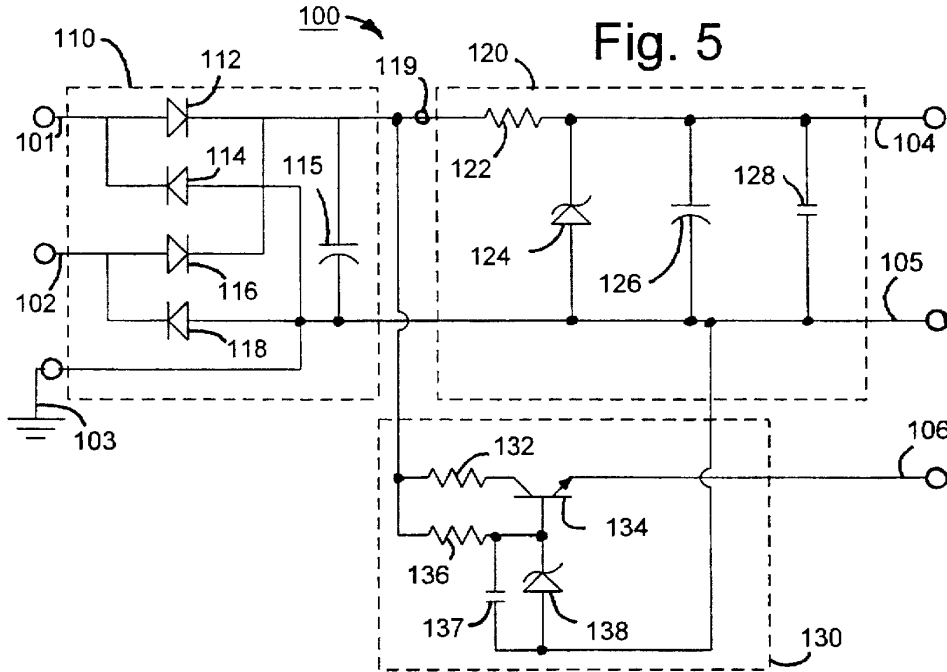

Fig. 4



S/N VS. BODY CAPACITANCE
TEMPERATURE = 105°C

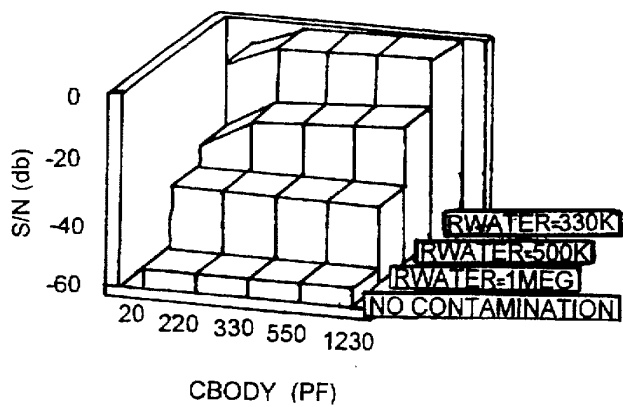

Fig. 9

S/N VS. BODY CAPACITANCE
TEMPERATURE = 25°C

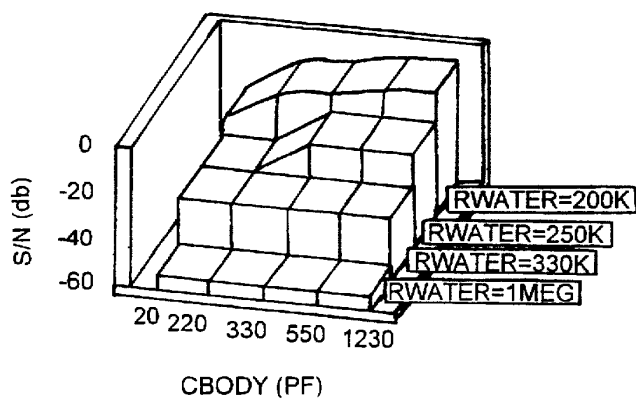
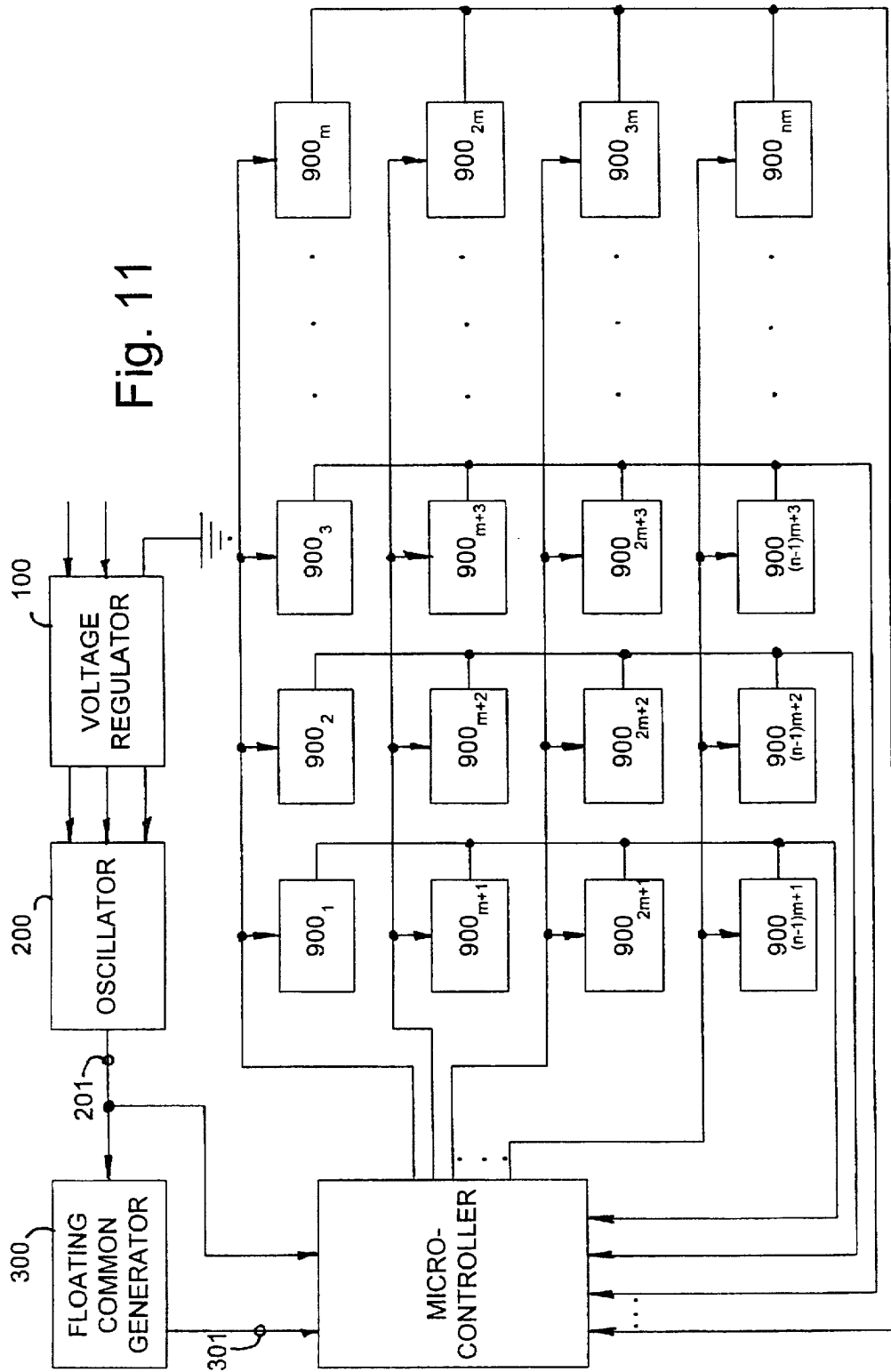

Fig. 10



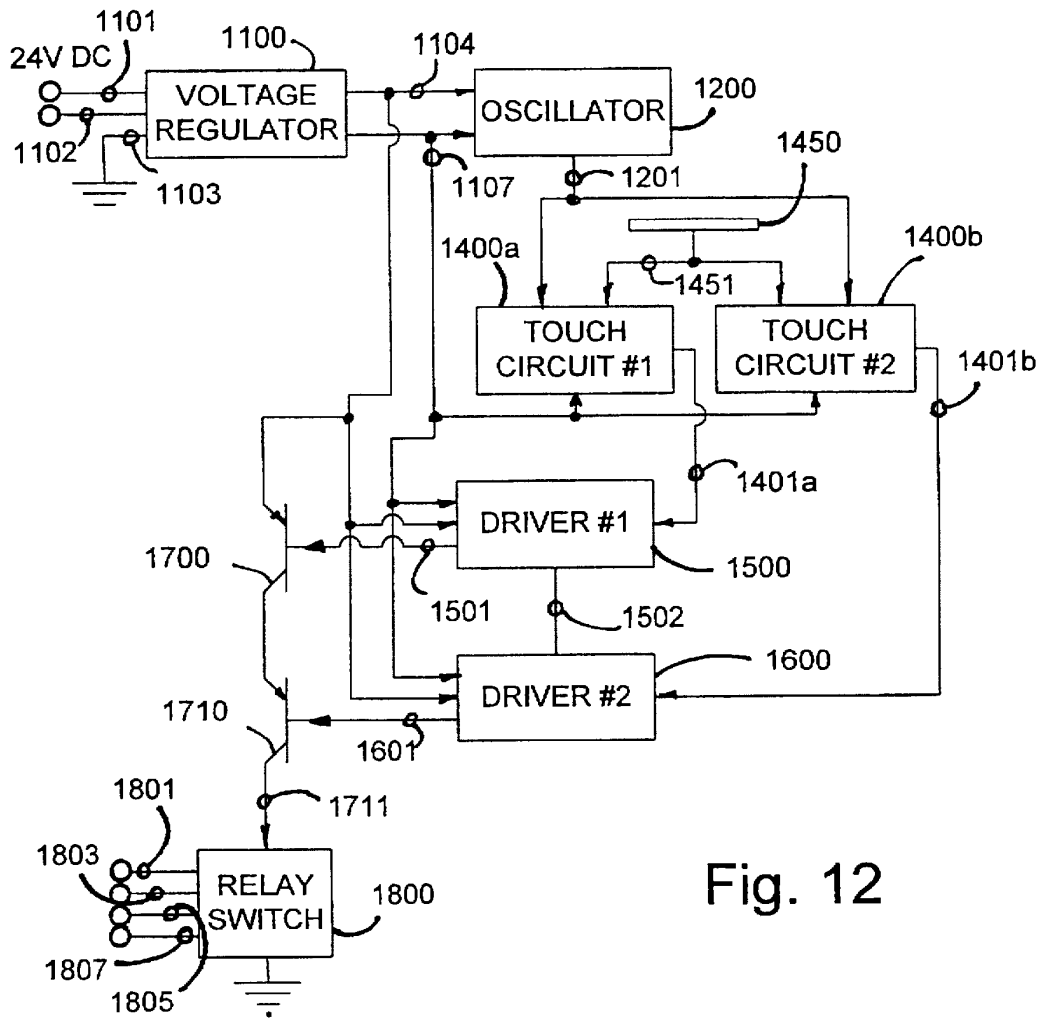

Fig. 12

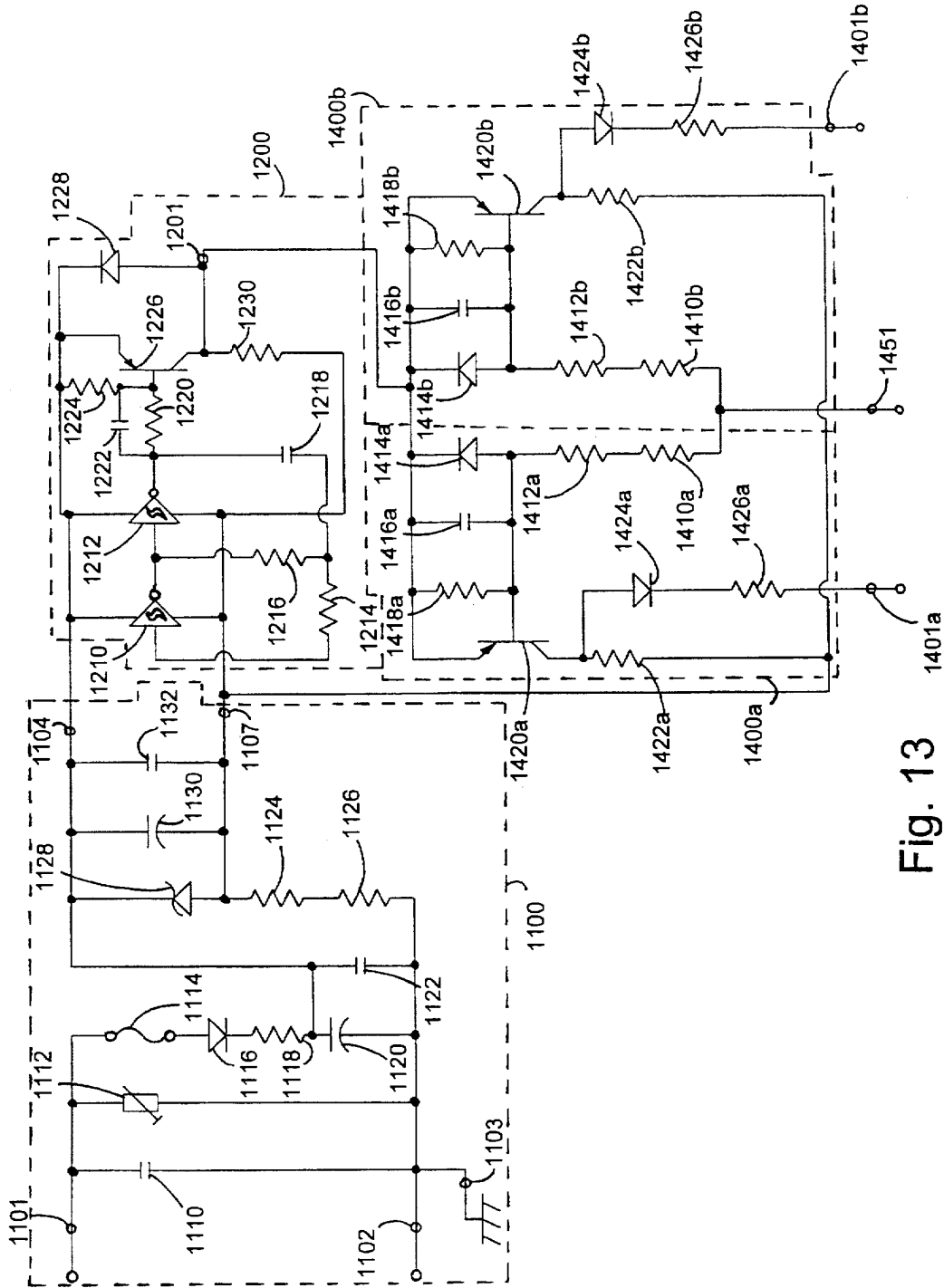

Fig. 13

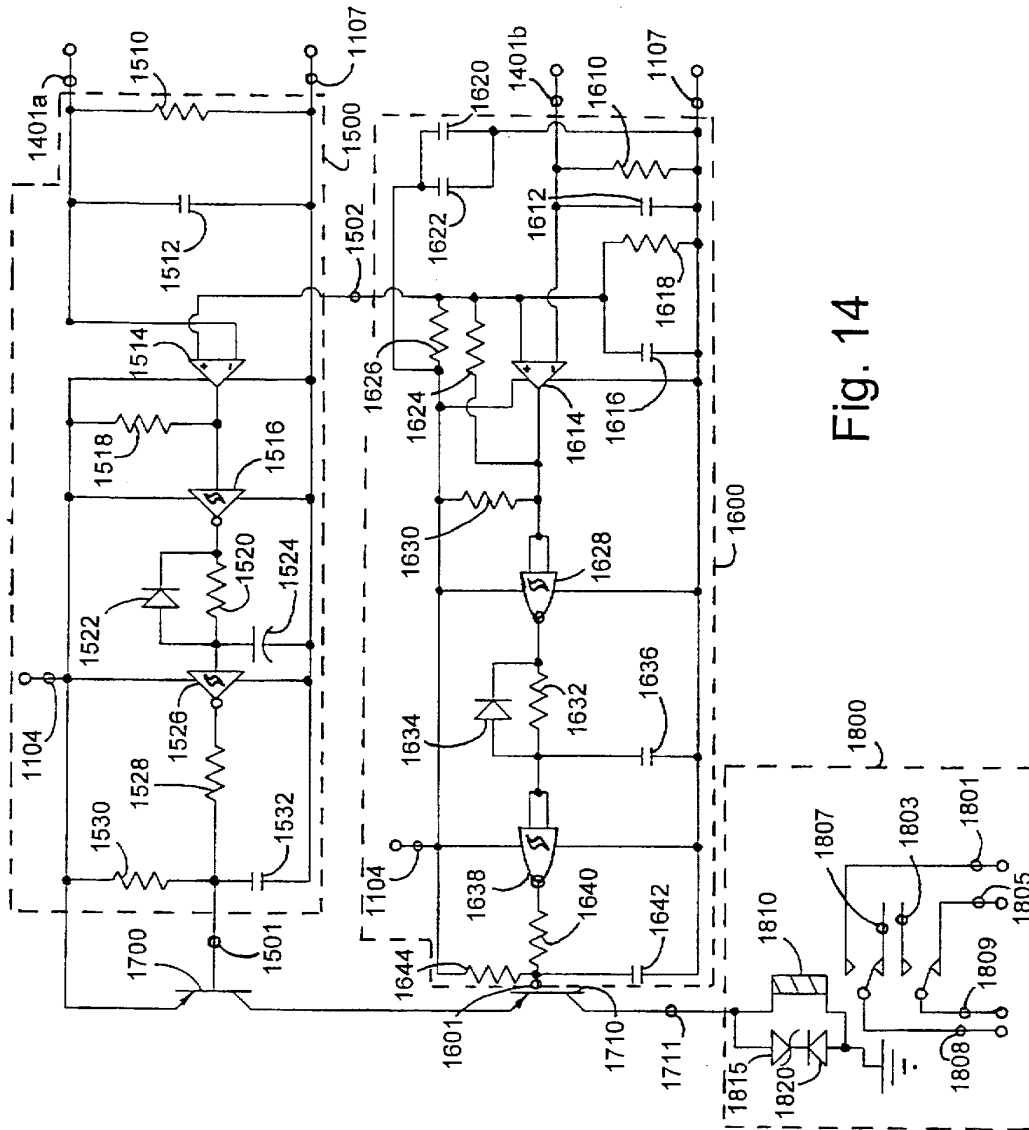
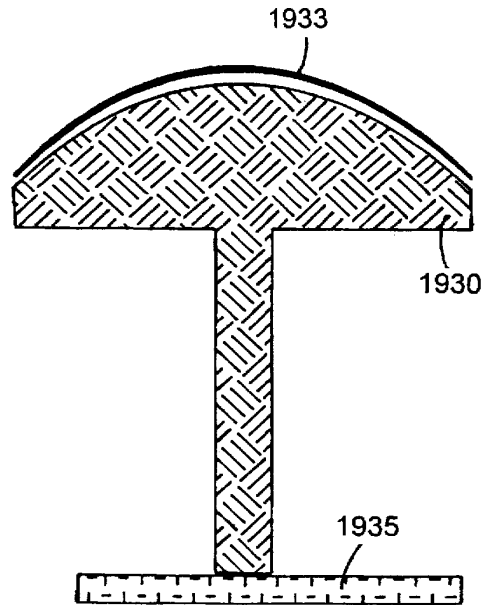
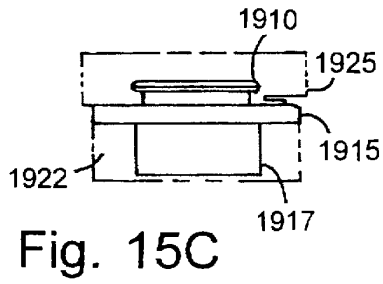
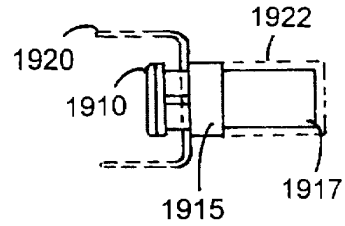
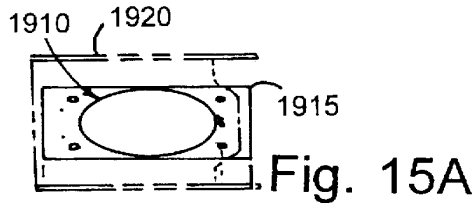

Fig. 14



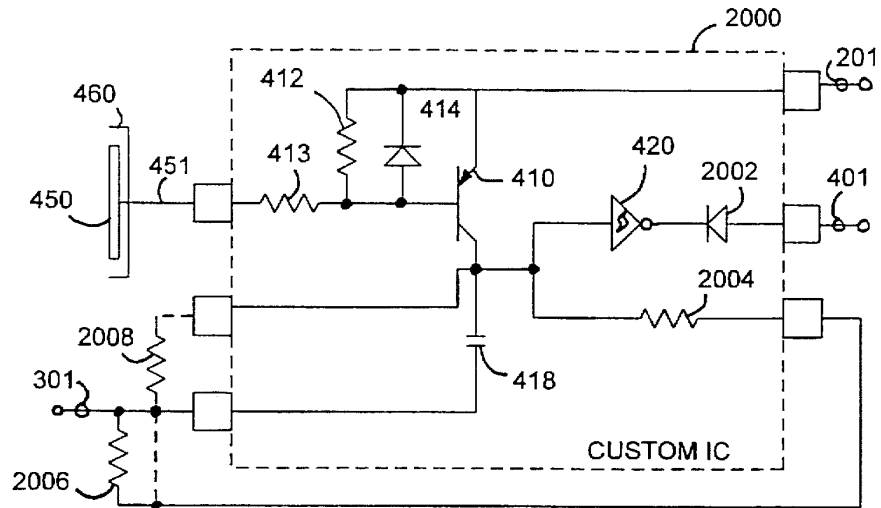

Fig. 17

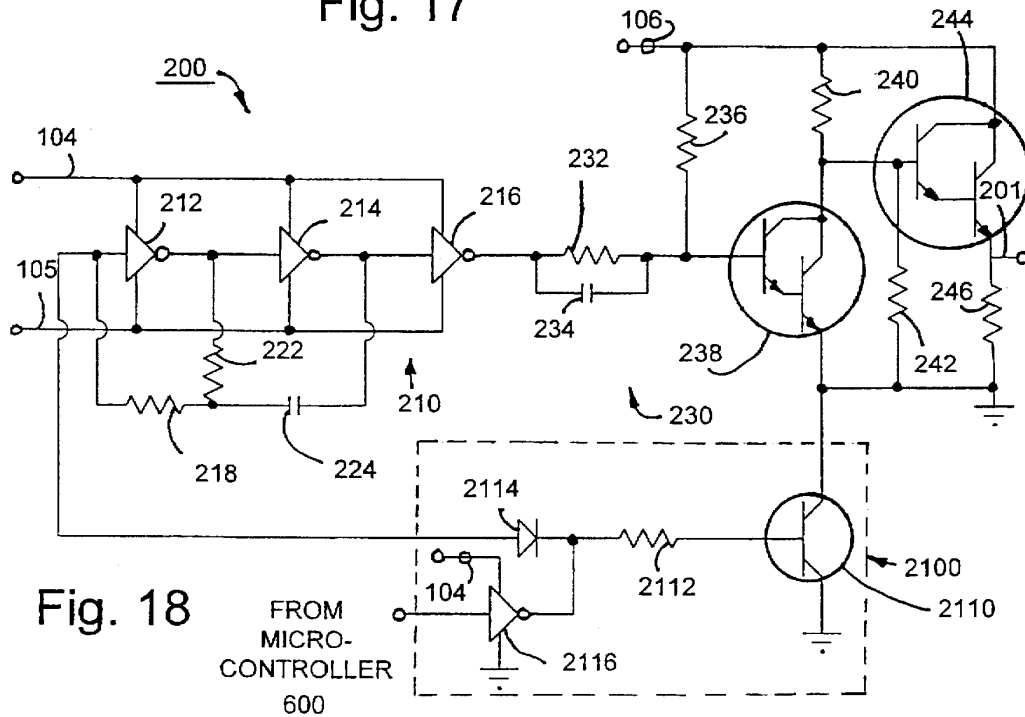
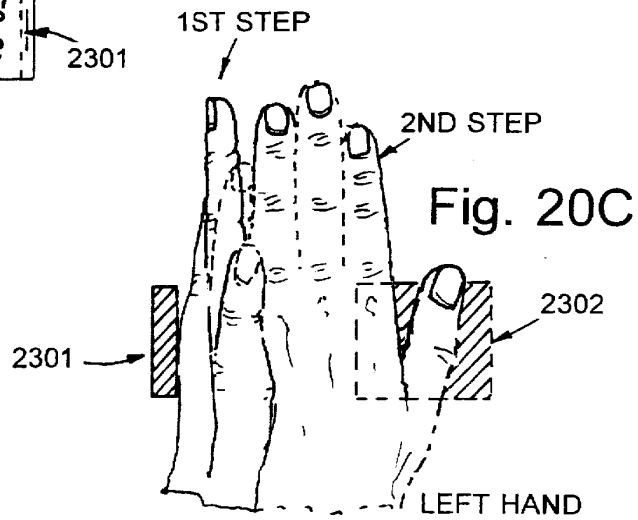
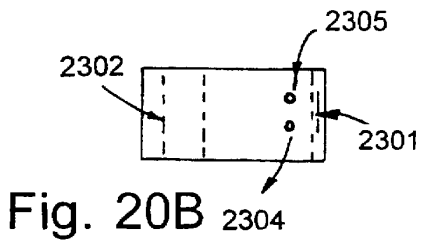
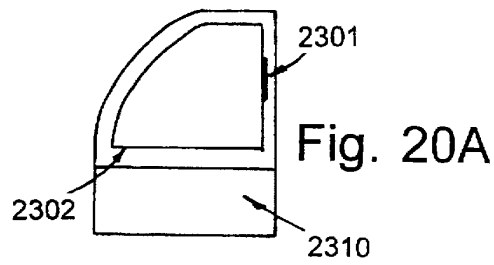
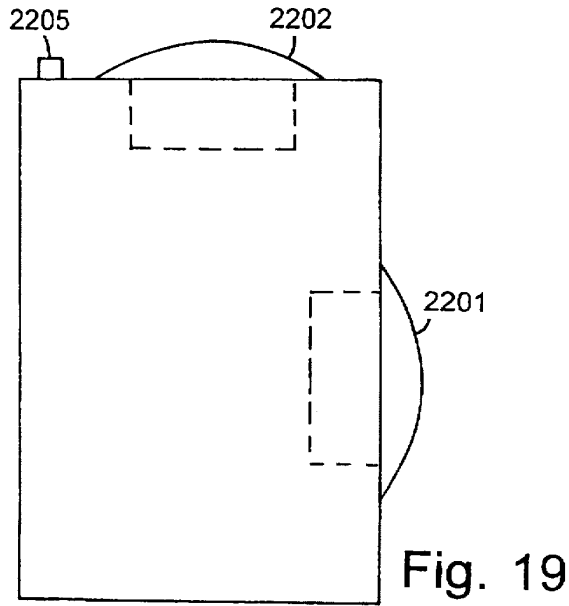

Fig. 18



CAPACITIVE RESPONSIVE ELECTRONIC SWITCHING CIRCUIT

BACKGROUND OF THE INVENTION

The present invention relates to an electrical circuit and particularly a capacitive responsive electronic switching circuit used to make possible a "zero force" manual electronic switch.

Manual switches are well known in the art existing in the familiar forms of the common toggle light switch, pull cord switches, push button switches, and keyboard switches among others. The majority of such switches employ a mechanical contact that "makes" and "breaks" the circuit to be switched as the switch is moved to a closed or an open condition.

Switches that operate by a mechanical contact have a number of well known problems. First, mechanical movements of components within any mechanism make those components susceptible to wear, fatigue, and loosening. This is a progressive problem that occurs with use and leads to eventual failure when a sufficient amount of movement has occurred.

Second, a sudden "make" or "break" between conductive contacts typically produces an electrical arc as the contacts come into close proximity. This arcing action generates both radio frequency emissions and high frequency noise on the line that is switched.

Third, the separation between contacts that occurs on each break, exposes the contact surfaces to corrosion and contamination. A particular problem occurs when the arc associated with a "make" or "break" occurs in an oxidizing atmosphere. The heat of the arc in the presence of oxygen facilitates the formation of oxides on the contact surfaces. Once exposed, the contact surfaces of mechanical switches are also vulnerable to contaminants. Water borne contaminants such as oils and salts can be a particular problem on the contact surfaces of switches. A related problem occurs in that the repeated arcing of mechanical contact can result in a migration of contact materials away from the area of the mechanical contact. Corrosion, contamination, and migration operating independently or in combination often lead to eventual switch failure where the switch seizes in a closed or opened condition.

An additional problem results from the mechanical force required in operating a mechanical switch. This problem occurs in systems where a human operator is required to repetitively operate a given switch or a number of switches. Such repetitive motions commonly occur in the operation of electronic keyboards such as those used with computers and in industrial switches such as used in forming and assembly equipment among other applications. A common type of industrial switch is the palm button seen in pressing and insertion equipment. For safety purposes, the operator must press the switch before an insertion or pressing can occur. This ensures that the operators hand(s) is(are) on the button (s) and not in the field of motion of the associated machinery. It also ensures that the mechanical motion occurs at a desired and controllable point in time. The difficulty arises from the motion and force required of the operator. In recent years, it has been noted that repeated human motions can result in debilitating and painful wear on joints and soft tissues yielding arthritis like symptoms. Such repetitive motion may result in swelling and cramping in muscle tissues associated with conditions such as Carpal Tunnel Syndrome. Equipment designers combat these Repetitive Motion or Cumulative

Trauma Disorders by adopting ergonomic designs that more favorably control the range, angle, number, and force of motions required of an operator as well as the number of the operator's muscle groups involved in the required motions. Prosthetics and tests are used as well to provide strain relief for the operator's muscles, joints, and tendons.

In mechanical switches, the force required to actuate the switch may be minimized by reducing spring forces and frictional forces between moving parts. However, reducing such forces makes such switches more vulnerable to failure. For instance, weaker springs typically lower the pressure between contacts in a "make" condition. This lower contact pressure increases the resistance in the switch which can lead to fatal heating in the switch and/or loss of voltage applied to the switched load. Reducing frictional forces in the switch by increasing the use of lubricants is undesirable because the lubricants can migrate and contaminate the contact surfaces. A switch designer may also reduce friction by providing looser fits between moving parts. However, looser fits tend to increase wear and contribute to earlier switch failure. A designer can also reduce friction by using higher quality, higher cost, surface finishes on the parts. Thus, as apparent from the foregoing description, measures taken to reduce actuator force in mechanical switch parts generally reduce the reliability and performance of the switch and/or increase the cost of the switch.

In applications such as computer keyboards or appliance controls, the electric load switched by a given switch can be quite low in terms of current and/or voltage. In such cases it is possible to use low force membrane switches such as described in U.S. Pat. No. 4,503,294. Such switches can relieve operator strain and are not as susceptible to arcing problems because they switch small loads. However, the flexible membrane remains susceptible to wear, corrosion, and contamination. Although such switches require very low actuation force, they are still mechanically based and thus suffer from the same problems as any other mechanical switch.

A more recent innovation is the development of "zero force" touch switches. These switches have no moving parts and no contact surfaces that directly switch loads. Rather, these switches operate by detecting the operator's touch and then use solid state electronics to switch the loads or activate mechanical relays or triacs to switch even larger loads. Approaches include optical proximity or motion detectors to detect the presence or motion of a body part such as in the automatic controls used in urinals in some public rest rooms or as disclosed in U.S. Pat. No. 4,942,631. Although these non-contact switches are by their very nature truly zero force, they are not practical where a multiplicity of switches are required in a small area such as a keyboard. Among other problems, these non-contact switches suffer from the comparatively high cost of electro-optics and from false detections when the operator's hand or other body part unintentionally comes close to the switch's area of detection. Some optical touch keyboards have been proposed, but none have enjoyed commercial success due to performance and/or cost considerations.

A further solution has been to detect the operator's touch via the electrical conductivity of the operator's skin. Such a system is described in U.S. Pat. No. 3,879,618. Problems with this system result from variations in the electrical conductivity of different operators due to variations in sweat, skin oils, or dryness, and from variable ambient conditions such as humidity. A further problem arises in that the touch surface of the switch that the operator touches must remain clean enough to provide an electrical conductivity path to

the operator. Such surfaces can be susceptible to contamination, corrosion, and/or a wearing away of the conductive material. Also, these switches do not work if the operator is wearing a glove. Safety considerations also arise by virtue of the operators placing their body in electrical contact with the switch electronics. A further problem arises in that such systems are vulnerable to contact with materials that are equally or more conductive than human skin. For instance, water condensation can provide a conductive path as good as that of an operator's skin, resulting in a false activation.

A common solution used to achieve a zero force touch switch has been to make use of the capacitance of the human operator. Such switches, which are hereinafter referred to as capacitive touch switches, utilize one of at least three different methodologies. The first method involves detecting RF or other high frequency noise that a human operator can capacitively couple to a touch terminal when the operator makes contact such as is disclosed in U.S. Pat. No. 5,066,898. One common source of noise is 60 Hz noise radiated from commercial power lines. A drawback of this approach is that radiated electrical noise can vary in intensity from locale to locale and thereby cause variations in switch sensitivity. In some cases, devices implemented using this first method, rely on conductive contact between the operator and the touch terminal of the switch. As stated, such surfaces are subject to contamination, corrosion, and wear and will not work with gloved hands. An additional problem can arise in the presence of moisture when multiple switches are employed in a dense array such as a keyboard. In such instances, the operator may touch one touch terminal, but end up inadvertently activating others through the path of conduction caused by the moisture contamination.

A second method for implementing capacitive touch switches is to couple the capacitance of the operator into a variable oscillator circuit that outputs a signal having a frequency that varies with the capacitance seen at a touch terminal. An example of such a system is described in U.S. Pat. No. 5,235,217. Problems with such a system can arise where conductive contact with the operator is required and where the frequency change caused by a touch is close to the frequency changes that would result from unintentionally coming into contact with the touch terminal.

Another method for implementing capacitive touch switches relies on the change in capacitive coupling between a touch terminal and ground. Systems utilizing such a method are described in U.S. Pat. No. 4,758,735 and U.S. Pat. No. 5,087,825. With this methodology the detection circuit consists of an oscillator (or AC line voltage derivative) providing a signal to a touch terminal whose voltage is then monitored by a detector. The touch terminal is driven in electrical series with other components that function in part as a charge pump. The touch of an operator then provides a capacitive short to ground via the operator's own body capacitance that lowers the amplitude of oscillator voltage seen at the touch terminal. A major advantage of this methodology is that the operator need not come in conductive contact with the touch terminal but rather only in close proximity to it. A further advantage arises in that the system does not rely upon radiated emissions picked up by the operator's body which can vary with locale, but relies instead upon the human body's capacitance, which can vary over an acceptable range of 20 pF to 300 pF.

An additional consideration in using zero force switches resides in the difficulties that arise in trying to employ dense arrays of such switches. Touch switches that do not require physical contact with the operator but rather rely on the

operator's close proximity can result in unintended actuations as an operator's hand or other body part passes in close proximity to the touch terminals. Above-mentioned U.S. Pat. No. 5,087,825 employs conductive guard rings around the conductive pad of each touch terminal in an effort to decouple adjacent touch pads and prevent multiple actuations where only a single one is desired. In conjunction with the guard rings, it is also possible to adjust the detection sensitivity by adjusting the threshold voltage to which the sensed voltage is compared. The sensitivity may be adjusted in this manner to a point where the operator's body part, for instance, a finger, has to entirely overlap a touch terminal and come into contact with its dielectric facing plate before actuation occurs. Although these methods (guard rings and sensitivity adjustment) have gone a considerable way in allowing touch switches to be spaced in comparatively close proximity, a susceptibility to surface contamination remains as a problem. Skin oils, water, and other contaminants can form conductive films that overlay and capacitively couple adjacent or multiple touch pads. An operator making contact with the film can then couple multiple touch pads to his or her body capacitance and it's capacitive coupling to ground. This can result in multiple actuations where only one is desired. Small touch terminals placed in close proximity by necessity require sensitive detection circuits that in some cases are preferably isolated from interference with the associated load switching circuits that they activate.

As mentioned, in industrial controls, switches can be used to control actuation time and to ensure that the operator's hand(s) or other body part(s) are out of the field of motion of associated machinery. A common type of switch used in this application is the palm button. The button is large enough so that the operator can rapidly bring his or her hand into contact with the button without having to lose the time that would be taken in acquiring and lining up a finger with a smaller switch. Zero force touch switches are also desirable in this application as Repetitive Motion or Cumulative Trauma Disorders have been a problem with operator's utilizing palm buttons—especially those palm buttons that must be actuated against a spring resistance. In this area capacitive touch switches have also been employed. U.S. Pat. No. 5,233,231 is an example of such an implementation. Due to the proximity of machinery with the potential to cause injury, false actuations are a particular liability in such applications. Capacitive touch switches that exhibit vulnerability to radiated electromagnetic noise or that operate off operator proximity have the potential to actuate when the operator's hand(s) is not at the desired location on the palm button(s). In general, this is addressed by the use of redundancies. In U.S. Pat. No. 5,233,231, a separate detector is used to measure RF noise and disable the system to a safe state if excessive RF noise is present. Other systems such as UltraTouch vended by Pinnacle Systems, Inc. use redundant sensing methodologies. In UltraTouch, both optical and capacitive sensors are used and actuation occurs only when both sensor types detect the operator's hand at the desired location. These implementations have a number of disadvantages. In the case of the RF noise detection system, the system is unusable in the presence of RF noise. This forces the user to employ a backup mechanical switch system or accept the loss of function when RF noise is present. The second system is less reliable and more expensive because it requires two sensor systems to accomplish the same task, i.e., detect the operator. Such system may also suffer from problems inherent in any optical system, namely, susceptibility to blockages in the optical path and the need to achieve and maintain specific optical alignments. A further problem

5

is that this system considerably constrains the angle and direction of motion that the operator must use in activating the switch.

Currently, there are several zero force palm buttons in the market. These products utilize optical and/or capacitive coupling to activate a normally closed (NC) or a normally open (NO) relay, and thereby switching 110 V AC, 220 V AC, or 24 V DC to machine controllers. The UltraTouch by Pinnacle Systems Inc. uses two sensors (infrared & capacitive) with isolated circuits to activate a relay when a machine operator inserts his hand into a U-shaped sensor actuation tunnel. The company claims that by permitting the machine operator to activate the machine with no force or pressure and with the operator's hand and wrist in the ergonomic neutral position (i.e. 0° wrist joint angle and 100% hand power positions as shown in FIG. 1.0-1), hand, wrist, and arm stresses are minimized and contributing elements to Carpal Tunnel Syndrome are negated. After a machine cycle is initiated, the operator must maintain an initial posture until the cycle is completed. A typical cycle time lasts approximately one to two seconds and is repeated about 3000 times daily. This adds up to about one hour to one hour and a half per day while the operator is in the posture. While this module reduces stress on wrist and hand, it strains the muscles in the forearm. Also, because of limited space permitted for the operator to insert his hand, it stresses the operator mentally and reduces productivity by causing fatigue. Furthermore, the infrared emitters and detectors rely on a clean path between the transmitter and receiver and will not operate properly if contaminants block the beam of light.

SUMMARY OF THE INVENTION

The present invention overcomes the above problems by using the method of sensing body capacitance to ground in conjunction with redundant detection circuits. Additional improvements are offered in the construction of the touch terminal (palm button) itself and in the regime of body capacitance to ground detection which minimizes sensitivity to skin oils and other contaminants. The invention also allows the operator to utilize the system with or without gloves which is a particular advantage in the industrial setting.

The specific touch detection method of the present invention has similarities to the devices of U.S. Pat. No. 4,758,735 and U.S. Pat. No. 5,087,825. However, significant improvements are offered in the means of detection and in the development of an overall system to employ the touch switches in a dense array and in an improved zero force palm button. The touch detection circuit of the present invention features operation at frequencies at or above 50 kHz and preferably at or above 800 kHz to minimize the effects of surface contamination from materials such as skin oils and water. It also offers improvements in detection sensitivity that allow close control of the degree of proximity (ideally very close proximity) that is required for actuation and to enable employment of a multiplicity of small sized touch terminals in a physically close array such as a keyboard. The circuitry of the present invention minimizes the force required in human operator motions and eliminates awkward angles and other constraints required in those motions. The outer surface of the touch switch typically consists of a continuous dielectric layer such as glass or polycarbonate with no mechanical or electrical feed-throughs. The surface can be shaped to have no recesses that would trap or hold organic material. As a result it is easily cleaned and kept clean and so is ideal for hygienic applications such as medical or food processing equipment.

6

In a first preferred embodiment the circuit offers enhanced detection sensitivity to allow reliable operation with small (finger size) touch pads. Susceptibility to variations in supply voltage and noise are minimized by use of a floating common and supply that follow the oscillator signal to power the detection circuit. The enhanced sensitivity allows the use of a 26V or lower amplitude oscillator signal applied to the touch terminal and detection circuit. This lower voltage (as compared to the device of U.S. Pat. No. 4,758,735) obviates the need for expensive UL listed higher voltage construction measures and testing to handle what would otherwise be large enough voltages to cause safety concerns. A further advantage of the present invention is seen in the manner in which the touch terminal detection circuit is interfaced to the touch terminals and to external control systems. A dedicated microprocessor referenced to the floating supply and floating common of the detection circuit maybe used to cost effectively multiplex a number of touch terminal detection circuits and multiplex the associated touch terminal output signals over a two line optical bus to a dedicated microprocessor referenced to a fixed supply and ground. An additional advantage of the microprocessor is an expanded ability to detect faults, i.e. a pad that is touched for an excessive amount of time that is known a priori to be an unlikely mode of operation or two or more pads touched at the same time or in an improper order. Additionally, the microprocessor can be used to distinguish desired multiple pad touches in simultaneous or sequential modes, i.e. two or more switches touched in a given order within a given amount of time. The microprocessor can be used to perform system diagnostics as well. The microprocessor also allows the use of visual indicators such as LEDs or annunciators such as a bell or tone generator to confirm the actuation of a given touch switch or switches. This is particularly useful in cases where a sequence of actuations is required before an action occurs. The feedback to the operator provided by a visual or audio indicator activated by the microprocessor in response to intermediate touches in a required sequence can minimize time lost and/or frustration on the part of the operator due to failed actuations from partial touches or wrong actuations from touching the wrong pad in a given required sequence or combination of touches. The second microprocessor may be used to communicate with the user's control system. Additional features include a "sleep mode" to minimize power consumption during periods of non-use or power brown outs, and redundant control circuits to facilitate "fail to safe" operation. Another improvement is offered in a means to move much of the cost of the system into simplified custom integrated circuits that allow ease of sensitivity adjustment and assembly.

In a second preferred embodiment, an improved palm button is featured. Through the use of a dielectric cover, a large metallic touch terminal can be used that differentiates between the touch of a finger or partial touch and the full touch of a palm. In this way the system avoids false triggers due to inadvertent finger touches or brushing contact with the palm prior or after an intended touch. The second embodiment also features redundant control circuits to facilitate "fail to safe" operation.

To achieve these and other advantages, and in accordance with the purpose of the invention as embodied and described herein, the capacitive responsive electronic switching circuit comprises an oscillator providing a periodic output signal having a frequency of 50 kHz or greater, an input touch terminal defining an area for an operator to provide an input by touch, and a detector circuit coupled to the oscillator for receiving the periodic output signal from the oscillator, and

7

coupled to the input touch terminal. The detector circuit being responsive to signals from the oscillator and the presence of an operator's body capacitance to ground coupled to the touch terminal when touched by an operator to provide a control output signal. Preferably, the oscillator provides a periodic output signal having a frequency of 800 kHz or greater.

These and other features, objects, and advantages of the invention may be realized and obtained by means of the instrumentalities and combinations particularly pointed out in the written description and claims hereof, as well as by the appended drawings.

BRIEF DESCRIPTION OF THE DRAWINGS

FIG. 1 is an electrical schematic of a testing circuit used to measure the impedance of the human body;

FIG. 2 is an electrical schematic of a testing circuit used to measure the impedance of water;

FIG. 3 is an electrical schematic of an equivalent circuit model for analyzing a human body in contact with glass covered with water;

FIG. 4 is a block diagram of a capacitive responsive electronic switching circuit constructed in accordance with a first embodiment of the present invention;

FIG. 5 is an electrical schematic of a preferred voltage regulator circuit for use in the capacitive responsive electronic switching circuit shown in FIG. 4;

FIG. 6 is an electrical schematic of a preferred oscillator circuit for use in the capacitive responsive electronic switching circuit shown in FIG. 4;

FIG. 7 is an electrical schematic of a preferred floating common generator circuit for use in the capacitive responsive electronic switching circuit shown in FIG. 4;

FIG. 8 is an electrical schematic of a preferred touch circuit for use in the capacitive responsive electronic switching circuit shown in FIG. 4;

FIG. 9 is a three dimensional bar graph illustrating signal-to-noise ratio vs. body capacitance at $T=105^{\circ}\text{C}$.;

FIG. 10 is a three dimensional bar graph illustrating signal-to-noise ratio vs. body capacitance at $T=22^{\circ}\text{C}$.;

FIG. 11 is a block diagram of a capacitive responsive electronic switching circuit constructed in accordance with a second embodiment of the present invention;

FIG. 12 is a block diagram of a capacitive responsive electronic switching circuit constructed in accordance with a third embodiment of the present invention;

FIG. 13 is an electrical schematic of a preferred voltage regulator, oscillator, and touch circuits for use in the capacitive responsive electronic switching circuit shown in FIG. 12;

FIG. 14 is an electrical schematic of preferred driver circuits for use in the capacitive responsive electronic switching circuit shown in FIG. 12;

FIGS. 15A-C are top, side, and front views, respectively, of an example of a flat palm button constructed in accordance with the present invention;

FIG. 16 is a cross-sectional view of an example of a dome-shaped palm button constructed in accordance with the present invention;

FIG. 17 is an electrical schematic of a touch circuit of the present invention implemented in a custom integrated circuit;

FIG. 18 is an electrical schematic of an oscillator having a sleeper circuit for use in the capacitive responsive electronic switching circuits of the present invention;

8

FIG. 19 is a pictorial view of a device having two palm buttons and an indicator light operated in accordance with the present invention; and

FIGS. 20A-C are pictorial views of another embodiment of the device shown in FIG. 19.

DETAILED DESCRIPTION OF THE PREFERRED EMBODIMENTS

As apparent from the above summary, the touch circuit of present invention operates at a higher frequency than prior touch sensing circuits. A move to high frequency operation (>50 to 800 kHz) is not a benign choice relative to the lower frequency (60 to 1000 Hz) operation seen in existing art such as U.S. Pat. No. 4,758,735 and U.S. Pat. No. 5,087,825. Higher frequencies require generally more costly, higher speed parts, and often results in the added cost of special design measures to minimize electronic emissions and the introduction of high frequency noise on power supply lines. The preference for using such higher frequencies is based on a study performed to determine if high frequency operation would allow a touch of an operator and conduction via surface contamination films, such as moisture, providing a conductive path from a non-touched area to the touched area. The study also determined whether a high frequency touch circuit could operate over a sufficiently wide temperature range, an assortment of overlying dielectric layer thicknesses and materials, and in the presence of likely power supply fluctuations. The following calculations and measurements are the results of this study. The results summarize the investigation conducted to reduce crosstalk due to condensation of water on the dielectric member (glass). By increasing the frequency of operation, the impedance of the body-glass combination is reduced as compared to the impedance of water between the touch pads.

The equivalent circuit of body impedance was measured using the testing circuit 10 shown in FIG. 1. Testing circuit 10 includes an oscillator 20 coupled between ground plate and a $100\text{ k}\Omega$ series resistor 22 and in parallel with a $10\text{ M}\Omega$ resistor 24, a 20 pF capacitor 26, and contacts for connecting to a human body identified in the figure as an impedance load 15 having an impedance Z_B representing the body's impedance.

Two types of measurements were taken: one with the person under test standing on a large ground plane i.e., concrete slab; and another while standing on a subfloor. The subfloor was used to simulate a typical northern home, i.e., wood joists with plywood sheeting. Carpeting was used as an added insulation layer. Table 1 below shows the measured body resistance and capacitance for five individuals.

TABLE 1

	CONCRETE SLAB	CONCRETE SLAB	SUBFLOOR	SUBFLOOR
	1.4 k Ω	100 pF	1.7 k Ω	73 pF
	1.4 k Ω	217 pF	1.9 k Ω	78 pF
	1.3 k Ω	174 pF	1.9 k Ω	93 pF
	1.2 k Ω	160 pF	1.6 k Ω	85 pF
	1.0 k Ω	107 pF	1.4 k Ω	75 pF

As apparent from Table 1 above and the discussion to follow, a human body's impedance may be represented by the series combination of a 20 - 300 pF capacitor and a 1 k - $2\text{ k}\Omega$ resistor.

The impedance of water, which is mainly resistive, was measured using the testing circuit 30 shown in FIG. 2. Testing circuit 30 includes an oscillator 40 coupled in series with a $1\text{ M}\Omega$ resistor 42 and contacts across which water is

applied to define an impedance load 35 having an impedance Z_w , representing the impedance of water. A true RMS voltage meter 45 is connected across the contacts of the impedance load 35.

The resistance of tap water over a 1x1 inch area and 1/32 inch deep, was measured to be around 160 kΩ.

The following calculation is for resistance of rain water where c is the conductivity for rain:

$$R = \left(\frac{1}{cin} \right) \times \left(\frac{L}{A} \right) \tag{Eq. 1}$$

where,

$$c = 128 \times 10^{-6} (\Omega - \text{cm})^{-1}$$

$$cin = c \left(\frac{100 \text{ cm}}{\text{m}} \right) \left(\frac{.0254 \text{ m}}{\text{in}} \right)$$

$$L = 1.0 \text{ in}$$

$$A = (1.0) \times \left(\frac{1}{32} \right) = \frac{1}{32} \text{ in}^2$$

therefore,

$$R = \left(\frac{1}{325.12 \times 10^{-6}} \right) \times \left(\frac{1.0 \text{ in}}{\frac{1}{32} \text{ in}^2} \right) = 98.43 \text{ k}\Omega$$

However, the thickness of a layer of water condensed on the surface of glass is much less than 1/32 inch and its resistance is higher than that of tap water. For design purposes, a resistance value of 1 MΩ was used to simulate water.

The capacitance of a piece of glass measuring 1/2"x1/2"x1/4", is approximately 2 pF.

$$C = K_{\text{glass}} K_a \frac{A(\text{cm}^2)}{L(\text{cm})} \text{ (}\mu\text{F)} \tag{Eq. 2}$$

$$K_a = 0.08842 \times 10^{-6} \text{ for vacuum}$$

$$6.0 < K_{\text{glass}} < 10$$

$$A = 0.25 \text{ in}^2$$

$$L = 0.25 \text{ in}$$

therefore,

$$C_{\text{max}} = 10 \times 0.08842 \times 10^{-6} \times 2.54 \times 10^{-6} = 2.25 \text{ pF}$$

$$C_{\text{min}} = 6 \times 0.08842 \times 10^{-6} \times 2.54 \times 10^{-6} = 1.35 \text{ pF}$$

Table 2 below shows the dielectric constant for several types of glass:

TABLE 2

TYPE OF GLASS	Dielectric Constant (K)
Corning 0010	6.32
Corning 0080	6.75
Corning 0120	6.65
Corning 8870	9.5

The equivalent circuit 50 of body touching the glass with the presence of water is shown in FIG. 3. As shown, the equivalent circuit 50 includes a polycarbon (PCB) plate 55 having at least two pads 57 and 59 formed thereon, a glass plate 60 adjacent to PCB plate 55, water 65 on glass plate 60 spanning at least two touch pad areas, and a body 70 in

contact with the water 65 and glass plate 60 at one touch pad area. The impedance of glass plate 60 is approximated by two 2 pF capacitors 62 and 64 connected to pads 57 and 59, respectively. The water 65 is approximated by a 1 MΩ resistor 68 connected between capacitors 62 and 64. The body is represented by a 20–300 pF capacitor 72 coupled at one end to water resistor 68 and glass plate capacitor 62, and by a 1–2 kΩ resistor 74 coupled between the other end of capacitor 72 and ground.

Referring to FIG. 3, it can be seen that a human touch opposite pad 57 will couple pad 57 to ground through the capacitance of glass 62 and the series contact with the human body impedance provided by the 20–300 pF capacitance and the 1 k–2 kΩ resistance of a typical human body. This will have the effect of pulling any voltage on the pad towards ground. Pad 59 will be similarly effected, however it's coupling to ground will not only be through capacitance 64, and the series capacitance and resistance of the human body, but will also be through the ohmic resistance of water on the glass cover between the proximate location of pad 59 and the touched pad 57. Because the human capacitance is considerably greater than the 2 pF capacitance of the glass, the impedance of the path to ground for pads 57 and 59 will be dominated by the glass and water impedances. If the impedance of the water path is significant compared to that of the glass, then the effect of a touch will be more significant at pad 57 than at pad 59. To overcome the effect of condensation or possible water spills, the impedance of the glass is preferably made as small as is practical compared to the impedance of the water. This allows discrimination between touched and adjacent pads. As the water impedance is primarily resistive and the glass impedance is primarily capacitive, the impedance of the glass will drop with frequency.

FIG. 3A shows the maximum and minimum glass impedance as a function of frequency. The maximum and minimum glass impedances shown were computed as follows:

$$\epsilon_o = 8.854 \times 10^{-12} \text{ C}^2 / (\text{nm}^2)$$

$$K_{\text{min}} = 6$$

$$K_{\text{max}} = 10$$

$$A = 0.25 \text{ in}^2$$

$$L = 0.25 \text{ in}$$

$$C_{\text{max}} = K_{\text{max}} \epsilon_o A / L \quad C_{\text{max}} = 2.249 \text{ pF}$$

$$C_{\text{min}} = K_{\text{min}} \epsilon_o A / L \quad C_{\text{min}} = 1.349 \text{ pF}$$

$$Z_{\text{gmin frequency}} = 1 / (2 \pi C_{\text{max}} \text{ frequency})$$

$$Z_{\text{gmax frequency}} = 1 / (2 \pi C_{\text{min}} \text{ frequency})$$

As can be seen, at 1 kHz, the capacitive impedance of the glass is much greater than the nominal 1 MΩ of the water bridge between the pads. As a result, at 1 kHz, there would be little difference in the impedance paths to ground of the two adjacent pads when either is touched. This would result in the voltage on both pads being pulled towards ground by comparable amounts. Conversely, at 100 kHz, the glass impedance drops to approximately 1 MΩ resulting in the impedance of the path to ground for pad 59 being twice that of the touched pad 57. For cases where background noise and temperature drifts are comparatively small, a 100 kHz oscillator frequency would allow a sufficiently low detection threshold to be set to differentiate between the signal changes induced at both pads by a human touch opposite a

single pad. At 800 kHz, the impedance of the glass drops to 200 k Ω or lower giving a ratio of a greater than 5 to 1 impedance difference between the paths to ground of the touched pad 57 and adjacent pads 59. In fact, the impedance ratio may exceed 10 to 1, as illustrated in the calculation below. This allows the detection threshold for the touched pad to be set well below that of an adjacent pad resulting in a much lower incidence of inadvertent actuation of adjacent touch pads to that of the touched pad. Ideally, the frequency of operation would be kept at the 800 kHz of the preferred embodiment or even higher. However, as noted earlier, higher frequency operation forces the use of more expensive components and designs. For applications where thermal drift and electronic noise levels are low, operation at or near 100 kHz may be possible. However, at 10 kHz and below, the impedance of the glass becomes much greater than that of likely water bridges between pads resulting in adjacent pads being effected as much by a touch as the touched pad itself. Although the preferred frequency is at or above 100 kHz, and more preferably at or above 800 kHz, it is conceivable that frequencies as low as 50 kHz could be used provided the frequency creates a difference in the impedance paths of adjacent pads that is sufficient enough to accurately distinguish between an intended touch and the touch of an adjacent pad. Use of frequencies as low as 50 kHz may also be possible depending upon the type of glass or covering or the thickness thereof used for the touch pad. However, in cases where there is little or no surface contamination, the frequency of operation can go well below 50 kHz. Ultimately, the frequency chosen will be a tradeoff between the likelihood of surface contamination and the cost of going to higher frequencies to prevent cross talk due to such contamination. The following analysis illustrates one example of how a frequency may be calculated based on the typical parameters used to construct a touch switch and the typical impedance of a contaminant, such as rain water. In the analysis below a 10 to 1 ratio of water to glass impedance is sought.

To eliminate crosstalk due to condensation of water on the glass, the impedance of body (Z_B) and glass (Z_g) combination must be much lower than impedance of water (Z_w). Since the impedance of glass is much higher than body impedance, Z_g will be considered only. Therefore,

$$10|Z_g| < |Z_w| \quad \text{Eq. 3}$$

where,

$$C_{glass} = 2 \text{ pF} \quad Z_w = 1 \text{ M}\Omega$$

$$Z_g = \frac{1}{2\pi f C_g} = \frac{7.96 \times 10^{10}}{f} \quad \text{Eq. 4}$$

$$10 \times \left(\frac{7.96 \times 10^{10}}{f} \right) < 1 \text{ M}\Omega$$

Therefore,

$$f > 796 \text{ kHz}$$

Having provided a basis for the use of higher frequencies, the basic construction of the electronic switching circuit constructed in accordance with a first embodiment of the present invention is now described with reference to FIG. 4. The electronic switching circuit includes a voltage regulator 100 including input lines 101 and 102 for receiving a 24 V AC line voltage and a line 103 for grounding the circuit. Voltage regulator 100 converts the received AC voltage to a

DC voltage and supplies a regulated 5 V DC power to an oscillator 200 via lines 104 and 105. Voltage regulator also supplies oscillator 200 with 26 V DC power via line 106. The details of voltage regulator 100 are discussed below with reference to FIG. 5.

Upon being powered by voltage regulator 100, oscillator 200 generates a square wave with a frequency of 50 kHz, and preferably greater than 800 kHz, and having an amplitude of 26 V peak. The square wave generated by oscillator 200 is supplied via line 201 to a floating common generator 300, a touch pad shield plate 460, a touch circuit 400, and a microcontroller 500. Oscillator 200 is described below with reference to FIG. 6.

Floating common generator 300 receives the 26 V peak square wave from oscillator 200 and outputs a regulated floating common that is 5 volts below the square wave output from oscillator 200 and has the same phase and frequency as the received square wave. This floating common output is supplied to touch circuit 400 and microcontroller 500 via line 301 such that the output square wave from oscillator 200 and floating common output from floating common generator 300 provide power to touch circuit 400 and microcontroller 500. Details of floating common generator 300 are discussed below with reference to FIG. 7.

Touch circuit 400 senses capacitance from a touch pad 450 via line 451 and outputs a signal to microcontroller 500 via line 401 upon detecting a capacitance to ground at touch pad 450 that exceeds a threshold value. The details of touch circuit 400 are described below with reference to FIG. 8.

Upon receiving an indication from touch circuit 400 that a sufficient capacitance to ground (typically at least 20 pF) is present at touch pad 450, microcontroller 500 outputs a signal to a load-controlling microcontroller 600 via line 501, which is preferably a two way optical coupling bus. Microcontroller 600 then responds in a predetermined manner to control a load 700. Having generally described the basic construction of the first embodiment, the preferred detailed construction of the depicted components will now be described with FIGS. 5-8. In cases where the number of lines to be switched is low, microcontroller 600 can be replaced by additional optical coupling lines. The number of lines to be switched will dictate whether it is more cost effective to multiplex over a two line optical bus such as line 501 and use a microcontroller to demultiplex, or to use a multiplicity of optical coupling lines. Other considerations such as reliability and power consumption may also affect this choice. In this preferred embodiment, the use of a single pair of optical coupling paths (line 501) and a microcontroller 600, is shown to emphasize the capability to switch a large number of lines.

A preferred circuit for implementing a voltage regulator 100 is shown in FIG. 5. Voltage regulator 100 preferably includes an AC/DC convertor 110 for generating 29 V to 36 V unregulated DC on line 119. This unregulated DC power is supplied to a 5 V DC regulator 120 and to a 26 V DC regulator 130. AC/DC convertor 110 includes diodes 112, 114, 116, and 118, which rectify the supplied 24 V AC power provided on power lines 101 and 102. The anode of the first diode 112 is coupled to power line 101 and to the cathode of the second diode 114. The cathode of the first diode 112 is coupled to output line 119. The anode of the second diode 114 is coupled to ground via line 103 and to the anode of the fourth diode 118. The anode of the third diode 116 is coupled to the cathode of the fourth diode 118 and to power line 102. The cathode of the third diode 116 is coupled to line 119 and to the cathode of the first diode 112. The anode of the fourth diode 118 is coupled to ground via line 103. Diodes 112, 114, 116, and 118 are preferably diodes having part no. 1N4002

13

available from LITEON. AC/DC convertor **110** also preferably includes a capacitor **115** for filtering the rectified output of the diodes. Capacitor **115** is preferably a 1000 μF capacitor coupled between output line **119** and ground via line **103**.

The 5 V regulator **120** preferably includes a 500 Ω resistor **122** coupled between line **119** and 5 V output line **104**, and a zener diode **124**, a first capacitor **126**, and second capacitor **128** all connected and parallel between output power lines **104** and **105**. Preferably, zener diode **124** is a 5.1 V zener diode having part no. 1N4733A available from LITEON, first capacitor **126** has a capacitance of 10 μF , and second capacitor **128** has a capacitance of 0.1 μF .

The 26 V regulator **130** preferably includes a transistor **134** having a collector connected to line **119** via a first resistor **132**, a base connected to line **119** via a second resistor **136**, and an emitter coupled to the regulated 26 V output power line **106**. The 26 V regulator **130** also preferably includes a capacitor **137** and zener diode **138** connected in parallel between the base of transistor **134** and ground line **103**. Preferably, first resistor **132** is a 20 Ω , 0.5 W resistor, second resistor **136** is a 1 k Ω , 0.5 W resistor, capacitor **137** is a 0.1 μF capacitor, and zener diode **138** is a 27 V, 0.5 W diode having part no. 1N5254B available from LITEON. It will be apparent to those skilled in the art, that various components of voltage regulator **100** may be added or excluded depending upon the source of power available to power the oscillator **200**. For example, if the available power is a 110 V AC 60 Hz commercial power line, a transformer may be added to convert the 110 V AC power to 24 V AC. Alternatively, if a DC battery is used, the AC/DC convertor among other components may be eliminated.

A preferred example of an 800 kHz oscillator is shown in FIG. 6. Oscillator **200** preferably includes a square wave generator **210**, which is powered by 5 V regulator **120** via lines **104** and **105**, for generating a 5 V peak square wave having the desired frequency, and a buffer circuit **230** powered by 26 V regulator **130** via line **106** for buffering the output of square wave generator **210** and boosting its peak from 5 V to 26 V while maintaining the preferred frequency. Square wave generator **210** is preferably an astable multivibrator constructed with at least two serially connected inverter gates **212** and **214**, and optionally, a third serially connected inverter gate **216**. Inverter gates **212**, **214** and **216** are preferably provided in a single integrated circuit designated as part 74HC04 available from National Semiconductor. The output of the first inverter gate **212** is coupled to its input via resistors **218** and **222** and is coupled to the output of the second inverter gate **214** via a capacitor **224**. The input of the second inverter gate **214** is directly connected to the output of the first inverter gate **212** and the output of the second inverter gate **214** is directly connected to the input of the optional third inverter gate **216**. To provide an 800 kHz output, resistor **218** preferably has a 10.0 k Ω value, resistor **222** preferably has a 1.78 k Ω value, and capacitor **224** is preferably a 220 pF capacitor.

The 5 V peak square wave generated by square wave generator **210** is supplied from either the output of inverter gate **214** or the output of optional inverter gate **216** to the base of a first transistor **238** via a first resistor **232** connected and parallel a capacitor **234**. The base of first transistor **238** is connected to the 26 V regulated DC power line **106** via a second resistor **236**. The collector of first transistor **238** is connected to 26 V power line **106** via a third resistor **240** and to the base of a second transistor **244**. The emitter of first transistor **238** is coupled to ground and to its own collector and the base of second transistor **244** via a fourth resistor **242**. The collector of the second transistor **244** is connected

14

directly to 26 V power line **106** and the emitter of second transistor **244** is connected to ground via a fifth resistor **246**. Second transistor **244** provides the 26 V peak square wave on output line **201**, which is connected to its emitter. In operation, the square wave signal applied to the base of transistor **238** causes the collector of transistor **238** to swing between near to the DC supply **106** voltage and the collector-emitter saturation voltage. Capacitor **234** is provided to improve the turning off of transistor **238**. Transistor **244** along with resistors **242** and **246** are used to buffer the square wave signal generated by transistor **238**. In a preferred embodiment, the values of the resistors and capacitor are as follows: first resistor **232** is 5.1 k Ω , capacitor **234** is 0.0047 μF , second resistor **236** is 1 M Ω , third resistor **240** is 1.6 k Ω , fourth resistor **242** is 100 k Ω , and fifth resistor **246** is 4.7 k Ω . Preferably, transistors **238** and **244** are those identified as part no. ZTX600 available from ZETEX. In this configuration, the oscillator **200** sources 80 mA to the floating common generator **300** such that together they supply a floating 5 V DC to power touch circuit(s) **400**, microcontroller **500**, and Schmitt triggered gates **420** (FIG. 8). As will be apparent to those skilled in the art, the values of the resistors and capacitors utilized in oscillator **200** may be varied from those disclosed above to provide for different oscillator output frequencies. As discussed above, however, oscillator **200** is preferably constructed so as to output a square wave having a frequency of 50 kHz or greater, and more preferably, of 800 kHz or greater. In some cases it may be necessary to use lower gain bandwidth product transistors or filtration to achieve a softer roll-off of the square edges to reduce high frequency noise emissions. When this is done the amplitude of the oscillator voltage can be increased to compensate.

The preferred construction of floating ground generator **300** is shown in FIG. 7 includes a zener diode **310** having a cathode connected to the oscillator output on line **201** and an anode connected to floating ground output line **301** and to ground via resistor **316** and diode **318**. Floating ground generator **300** also preferably includes a first capacitor **312** and a second capacitor **314** connected in parallel with zener diode **310**. In the preferred embodiment, zener diode **310** is a 5.1 V zener diode identified by part no. 1N4733A available from LITEON, capacitor **312** is a 47 μF tantalum capacitor, capacitor **314** is a 0.1 μF capacitor, resistor **316** is a 270 Ω resistor, and diode **318** is a diode identified as part no. 1N914B available from LITEON.

Touch circuit **400**, as shown in FIG. 8, preferably includes a transistor **410** having a base connected to touch pad **450** via resistor **413** and line **451**, an emitter coupled to oscillator output line **201**, and a collector coupled to floating ground line **301** via a pulse stretcher circuit **417**, which includes a resistor **416** and a capacitor **418** connected in parallel. To minimize susceptibility to noise, the physical length of the path between the touch pad **450** and the base of the transistor **410**, must be held to a minimum. Additionally, RC filters can be placed in line **401** between the output of the touch circuit **400** and the input of the microcontroller **500** to give additional EMI/RFI immunity. Additionally, the higher the frequency, the higher the gain bandwidth product that is required in transistor **410**. The gain bandwidth product must be sufficient to guarantee that the oscillator turns on during oscillator High pulses. A further trade-off is to use higher gain bandwidth product to allow lower oscillator voltages or higher oscillator voltages to all allow a lower gain bandwidth product transistor to be used. The combination of oscillator voltage, frequency and transistor gain bandwidth product that is used will necessarily vary with the cost,

safety and reliability requirements of a given application. The present combination was chosen to keep the oscillator voltage down and allow operation at 800 kHz to minimize cross talk. At higher frequencies a higher gain bandwidth product transistor would be required in both the oscillator 200 and detection 400 circuits. Touch circuit 400 also preferably includes resistor 412 and a diode 414 having an anode connected to the base of transistor 410 and to resistor 413, and a cathode connected to the emitter of transistor 410 and to a resistor 412 connected in parallel with diode 414 between the base and emitter of transistor 410. The pulse stretcher circuit 417 is identified as such because the sensitivity of the touch circuit may be increased or decreased by varying the resistance of resistor 416. The base of transistor 410 is connected via resistor 413 to line 451 connected to touch pad 450.

Additionally, touch circuit 400 may include at least one Schmitt triggered gate 420 powered by the voltage difference existing between oscillator line 201 and 301, and having an input terminal coupled to the collector of transistor 410 and an output coupled to microcontroller 500 via output line 401. Schmitt triggered inverter gate 420 is optionally provided to improve the rise time of the touch switch output and to buffer the output. Preferably, transistor 410 is part no. BC858CL available from Motorola, resistor 412 is a 12 M Ω resistor, diode 414 is part no. 1N914B available from Diodes, Inc., resistor 416 is a 470 k Ω resistor, capacitor 418 is a 0.001 μ F capacitor, and resistor 413 is a 10 k Ω resistor.

As stated above, the operator's body includes a capacitance to ground, which may range in a typical person from between 20 to 300 pF. The base terminal of transistor 410 is coupled to its emitter by resistor 412 such that unless capacitance is present by the user touching the touch pad 450, transistor 410 will not be forward biased and will not conduct. Thus, when touch pad 450 is not touched, the output signal at the collector terminal of transistor 410 and across pulse stretcher circuit 417 will be zero volts. When, however, a person touches the touch pad 450, that person's body capacitance to ground couples the base of transistor 410 to ground 103 through resistor 413, thereby forward biasing transistor 410 into conduction. This charges capacitor 418 providing a positive DC voltage with respect to the line 301 and causes the output of the Schmitt trigger 420 to go low. Diode 414 is coupled across the base to emitter junction of transistor 410 to clamp the base emitter reverse bias voltage to -0.7 V and also reduce the forward recovery and turn-on time.

Touch pad 450 includes a substrate on which a plurality of electrically conductive plate members are mounted on one surface thereof. The substrate is an insulator and the plates are spaced apart in order to insulate the plates from one another and from ground. Also, positioned on the substrate is a guard band, generally shown as 460. Guard band 460 is a grid of conductor segments extending between adjacent pairs of plate members. All conductor segments are physically interconnected to define a plurality of spaces with one plate member positioned centrally within each space. Components of the touch circuit may be positioned on the side of substrate opposite plate members and guard band 460.

A planar dielectric member is spaced from the substrate facing plate members. The dielectric member is made from a non-porous insulating material such as polycarbonate or glass. A plurality of electrically conductive spring contacts are sandwiched between the inner surface of the dielectric member and the substrate. An indicia layer may be adhered to the inner surface of the dielectric member to provide an indication of the function of each input portion.

As mentioned above, interface between the dielectric member and a conductive plate is a metallic spring contact that is attached to the back of the dielectric member. The spring contacts offer advantages at high temperature extremes. However, for sufficiently narrow temperature ranges, conductive polymer foam pads cut to the size of the touch pads are preferably used to fill the gap between conductive pad and dielectric layer. The function of the spring contacts or conductive foam pads is to eliminate that capacitive contribution of the air filled gap between the conductive pads and the overlying dielectric layer.

A problem with capacity responsive keyboards is the tendency of switches that are closely positioned in a keyboard system to inadvertently become actuated even though the user is touching an adjacent switch. Furthermore, this problem is greatly aggravated by the presence of contamination on the outer surface of dielectric member. Contamination such as skin oil or moisture causes erratic keyboard operation and multiple switches will turn on even though one switch is touched. By operating at a high frequency such as 100 kHz or 800 kHz, the impedance of the series combination of body and glass capacitance are lowered as compared to the impedance of contamination present on the glass thereby reducing crosstalk.

If glass thickness is smaller than $\frac{3}{16}$ inch, the touch circuit becomes more sensitive to body capacitance. There are two ways to adjust the sensitivity so that crosstalk does not occur: remove diode 414 and/or reduce the resistance of resistor 416. Increasing the resistance of resistor 416 would allow usage of thicker glass. However, this resistance preferably should not go above 750 k Ω . This is because of the maximum low input voltage of 0.8 V and input leakage current of 1 μ A at the Schmitt trigger gate 420.

The oscillator circuitry shown in FIG. 6 is very stable over the temperature range of -40° C. to 105° C. The output of the touch switch circuitry drops at a rate of approximately 40 mV/°C. when temperature falls below 0° C. If application requires operation at low temperatures (-40° C.), the following three methods may be used to increase the output of the switch: increase the oscillator's regulated supply voltage, increase the resistance of resistor 416, and use a higher gain transistor 410. All of these methods would increase sensitivity at high temperatures. Another way to correct this problem is to use a thermistor to vary the regulated supply voltage as a function of temperature.

Since the input power is regulated down to 26 V DC, variation of power (24 V AC \pm 10% or 29 V DC to 36 V DC) does not affect circuit operation. Table 3 below shows the measured output voltage of the switch for various supply voltages.

TABLE 3

SUPPLY VOLTAGE	SWITCH OUTPUT
36 VDC	4.96 V
35 VDC	4.96 V
34 VDC	4.95 V
33 VDC	4.95 V
32 VDC	4.94 V
31 VDC	4.93 V
30 VDC	4.93 V
29 VDC	4.92 V

$$PSRR=6 \text{ mV/V}=-45 \text{ dB}$$

In order to determine the effect of body capacitance on circuit operation, the circuit of FIG. 3 was used to simulate glass, water resistance, and body capacitance. The following two conditions were simulated and tested:

- 1—The maximum body capacitance that does not cause crosswalk when:
 Temperature=105° C.
 Supply Voltage=36VDC
 Glass Capacitance=2 pF
 Water Resistance=330 k to 1 MΩ
 - 2—The minimum capacitance to turn on a switch when:
 Temperature=0° C.
 Supply Voltage=29VDC
 Glass Capacitance=2 pF
 - 3—Operation at room temperature.
- Table 4 below shows the signal and noise voltages at the switch output for different values of body capacitance and contamination resistance.

TABLE 4

CONTAMINATION RESISTANCE	BODY CAPACITANCE				
	20 pF	220 pF	330 pF	550 pF	1230 pF
330 kΩ	S: 5.1 V N: 2.0 V	S: 5.1 V N: 4.0 V	S: 5.1 V N: 4.5 V	S: 5.1 V N: 4.9 V	S: 5.1 V N: 5.0 V
500 kΩ	S: 5.1 V N: 0.2 V	S: 5.1 V N: 0.6 V	S: 5.1 V N: 0.7 V	S: 5.1 V N: 0.8 V	S: 5.1 V N: 0.8 V
1 MΩ (Condensed Water)	S: 5.1 V N: 0.1 V	S: 5.1 V N: 0.1 V	S: 5.1 V N: 0.1 V	S: 5.1 V N: 0.1 V	S: 5.1 V N: 0.1 V
NONE	S: 5.1 V N: 10 mV	S: 5.1 V N: 10 mV	S: 5.1 V N: 10 mV	S: 5.1 V N: 10 mV	S: 5.1 V N: 10 mV

S = Signal (TOUCH)
 N = Noise (NO TOUCH)
 supply voltage = 36 VDC
 temperature = 105° C.

With contamination resistance of 1 MΩ or more, the circuit is insensitive to body capacitance variations and has a minimum signal-to-noise ratio of -34 dB. With no contamination, signal-to-noise ratio is approximately -54 dB. The graph in FIG. 9 shows the signal-to-noise ratio versus body capacitance, for different values of contamination resistance at 105° C. The minimum body capacitance to turn on a switch is 20 pF.

At room temperature, crosstalk decreases because of gain drop of transistor 410. Table 5 below shows that at room temperature, the circuit rejects 250 kΩ of contamination, independent of body capacitance. Below 250 kΩ, body capacitance will affect crosstalk.

TABLE 5

CONTAMINATION RESISTANCE	BODY CAPACITANCE				
	20 pF	220 pF	330 pF	550 pF	1230 pF
200 kΩ	S: 5.1 V N: 0.2 V	S: 5.1 V N: 1.0 V	S: 5.1 V N: 1.2 V	S: 5.1 V N: 1.8 V	S: 5.1 V N: 2.2 V
250 kΩ	S: 5.1 V N: 0.1 V	S: 5.1 V N: 0.1 V	S: 5.1 V N: 0.5 V	S: 5.1 V N: 0.5 V	S: 5.1 V N: 0.5 V
330 kΩ	S: 5.1 V N: 0.1 V	S: 5.1 V N: 0.1 V	S: 5.1 V N: 0.1 V	S: 5.1 V N: 0.1 V	S: 5.1 V N: 0.1 V
1 MΩ (Condensed Water)	S: 5.1 V N: 0.1 V	S: 5.1 V N: 0.1 V	S: 5.1 V N: 0.1 V	S: 5.1 V N: 0.1 V	S: 5.1 V N: 0.1 V

S = Signal (TOUCH)
 N = Noise (NO TOUCH)
 supply voltage = 36 VDC
 temperature = 25° C.

The graph of FIG. 10 shows the measured signal-to-noise ratio versus body capacitance, for different contamination resistance values at room temperature.

The particular advantages of the preceding circuit over that of existing touch detection circuits such as that disclosed in U.S. Pat. No. 4,758,735, are the use of diode 414 (selected for high speed) to minimize forward recovery time rather than merely provide reverse polarity protection (as with the slower type of diode used in the existing circuits) and the omission of a capacitor coupled across the base to emitter junction of the detection transistor 410 to make the circuit more sensitive and operable with a lower oscillator amplitude and higher oscillator frequency. These features along with appropriate choices in component values make possible operation at significantly higher frequencies (>50 to 800 kHz) than are seen in existing art (60 to 1000 Hz). At frequencies at or near 800 kHz, the 20-300 pF of capacitance to ground offered by the human body presents a considerably lower impedance than the primarily resistive impedance of skin oil or water films that may appear on the dielectric layer overlying the conductive touch pads. This allows the peak voltage of a pad that is touched to come considerably closer to ground than adjacent pads which will have a voltage drop across any contaminating film layer that is providing a conductive path to the area that is touched. The enhanced sensitivity offered by the omission of any capacitor between the base and emitter of the detection transistor 410, allows the threshold of detection to be set much closer to ground than would be the case otherwise. This allows discrimination between the pad that is touched and adjacent pads that might be pulled towards ground via the conductive path to the touch formed by a contaminating film. This high frequency regime of operation offers a considerable advantage relative to the existing art in terms of immunity to surface contaminants such as skin oil and moisture.

A multiple touch pad circuit constructed in accordance with the second embodiment is shown in FIG. 11. In the second embodiment of FIG. 11, components similar to those in the first embodiment in FIG. 4 are designated with the same references numerals and will not be discussed in detail. The multiple touch pad circuit is a variation of the first embodiment in that it includes an array of touch circuits designated as 900₁ through 900_{nm}, which, as shown, include both the touch circuit 400 shown in FIGS. 4 and 8 and the input touch terminal pad 451 (FIG. 4). Microcontroller 500 selects each row of the touch circuits 900₁ to 900_{nm} by providing the signal from oscillator 200 to selected rows of touch circuits. In this manner, microcontroller 500 can sequentially activate the touch circuit rows and associate the received inputs from the columns of the array with the activated touch circuit(s). To keep the path length 451 between the touch pad 450 and the base to the detection transistor 410 to a minimum, the detection circuits 900 are physically located directly beneath the touch pads. To simplify assembly, a flexible circuit board such as vended by Sheldahl, Inc. or Circuit Etching Technics, Inc. can be used for this purpose. Ideally, the printed circuit will be fixed directly against the surface (typically glass) bearing the conductive touch pads to eliminate air gaps and the need for conductive foam pads and spring contacts which were used to fill air gaps.

For this second embodiment, the oscillator 200 of the first embodiment may be slightly modified from that shown in FIG. 6 to include a transistor (not shown) coupled between the oscillator output and ground with its base connected to microcontroller 600 such that microcontroller 600 may selectively disable the output of oscillator 200.

The use of a high frequency in accordance with the present invention provides distinct advantages for circuits

such as the multiple touch pad circuit of the present invention due to the manner in which crosstalk is substantially reduced without requiring any physical structure to isolate the touch terminals. Further, the reduction in crosstalk afforded by the present invention, allows the touch terminals in the array to be more closely spaced together.

A third embodiment of the present invention, which provides touch circuit redundancy, is described below with reference to FIGS. 12-14. As shown in FIG. 12, the switching circuit according to the third embodiment includes a voltage regulator 1100 for regulating power supplied by 24 V DC power lines 1101 and 1102 with ground connection 1103, for supplying the regulated power to an oscillator 1200 via lines 1104 and 1107.

Oscillator 1200 supplies a continuous and periodic signal to touch circuits 1400a and 1400b via line 1201. Preferably, the frequency of the oscillator output signal is at least 100 kHz, and more preferably, at least 800 kHz. The two touch circuits 1400a and 1400b are identical in construction and both receive the output of touch terminal 1450 via line 1451. A detailed description of the preferred voltage regulator circuit 1100, oscillator 1200, and touch circuits 1400a and 1400b is provided below with reference to FIG. 13 following the description of the remaining portion of the third embodiment.

The output of the first touch circuit 1400a is supplied to a first driver circuit 1500 via line 1401a while the output of the second touch circuit 1400b is supplied to a second driver circuit 1600 via line 1401b. The two driver circuits 1500 and 1600 are provided to drive first and second serially connected switching transistors 1700 and 1710. The switching transistors 1700 and 1710 must both be conducting to supply power to a relay switch 1800. Thus, if one of touch circuits 1400a and 1400b does not detect a touch of touch terminal 1450, one of switching transistors 1700 and 1710 will not conduct and power will not be supplied to relay switch 1800. The preferred construction of driver circuits 1500 and 1600 and relay switch 1800 are described below with reference to FIG. 14.

As shown in FIG. 13, voltage regulator 1100 may be constructed by providing a first capacitor 1110 and a varistor 1112 connected in parallel across input power terminals 1101 and 1102. Preferably, return power terminal 1102 is connected via line 1103 to ground. Varistor 1112 is used to protect the circuit for over-voltage conditions. Also connected in parallel with first capacitor 1110 and varistor 1112, are the serially connected combination of a fuse 1114, a diode 1116, a resistor 1118 and two parallel connected capacitors 1120 and 1122. The voltage regulator 1100 is reverse polarity protected by diode 1116 and current limited by resistor 1118. Capacitors 1120 and 1122 provide filtering.

Voltage regulator 1100 further includes a zener diode 1128 having its cathode connected to a node between resistor 1118 and capacitors 1120 and 1122 and to output power line 1104. The anode of zener diode 1128 is coupled to output power common line 1107 and to ground line 1103 via two serially connected resistors 1124 and 1126. Zener diode 1128 and resistors 1124 and 1126 generate regulated 15 V DC. Two capacitors 1130 and 1132 are connected in parallel with zener diode 1128 between power lines 1104 and 1107. Capacitors 1130 and 1132 provide filtering and decoupling, respectively. Preferably, capacitor 1110 has a capacitance of 1000 pF, 1000V, varistor 1112 is part no. S14K25 available from Siemens, fuse 1114 is a ¼A fuse, diode 1116 is part no. 1N4002 available from LITEON, resistor 1118 has a resistance of 10Ω, ½W, capacitor 1120 has a capacitance of 22 μF, 35V, capacitor 1122 has a

capacitance of 0.1 μF, zener diode 1128 is part no. 1N4744A available from LITEON, resistor 1124 has a resistance of 220Ω, resistor 1126 has a resistance of 220Ω, capacitor 1130 has a capacitance of 1 μF, 25V, and capacitor 1132 has a capacitance of 0.1 μF.

Oscillator 1200 is preferably comprised of a first inverter gate 1210 having its input coupled to its output via resistors 1214 and 1216, and a second inverter gate 1212 having its input coupled to the output of first inverter gate 1210 and its output coupled to its input via a capacitor 1218 and resistor 1216. The oscillating output of the second inverter gate 1212 is buffered via transistor 1226, which has its base connected to the output of second inverter gate 1212 via resistor 1220 and capacitor 1222, which are connected in parallel therebetween. The base of transistor 1226 is also coupled to power line 1104 via a resistor 1224. The emitter of transistor 1226 is connected to power line 1104 and the collector is connected to power line 1107 via a resistor 1230, to the anode of a diode 1228, and to the oscillator output line 1201. Diode 1228 has its cathode connected to power line 1104 and is used to protect transistor 1226.

Preferably, inverter gates 1210 and 1212 are provided by part no. CD40106B available from Harris, resistor 1214 has a resistance of 10 kΩ, resistor 1216 has a resistance of 1.18 kΩ, 1%, capacitor 1218 has a capacitance of 220 pF, resistor 1220 has a resistance of 4.7 kΩ, capacitor 1222 has a capacitance of 220 pF, resistor 1224 has a resistance of 100 kΩ, transistor 1226 is part no. MMBTA70L available from Motorola, diode 1228 is part no. RLS4448 available from LITEON, and resistor 1230 has a resistance of 3.3 kΩ.

Two touch circuits 1400a and 1400b are provided in parallel to provide redundancy so that if one fails, the relay drivers are disabled. Because the touch circuits 1400a and 1400b are identical, only one of the touch circuits will now be described. Touch circuit 1400a preferably includes two resistors 1410a and 1412a coupled in series between touch terminal output line 1451 and the base of a bipolar PNP transistor 1420a. Transistor 1420a has its emitter connected to the oscillator output line 1201 and its collector connected to power common line 1107 via a resistor 1422a. Touch circuit 1400a further includes a diode 1414a, a capacitor 1416a, and a resistor 1418a all connected in parallel between the base of transistor 1420a and the emitter thereof, which is connected to oscillator output line 1201. Touch circuit 1400a also includes a diode 1424a having its anode connected to the collector of transistor 1420a and its cathode connected to touch circuit output line 1401a via a resistor 1426a.

Preferably, resistor 1410a has a resistance of 5.1 kΩ, resistor 1412a has a resistance of 5.1 kΩ, diode 1414a is part no. RLS4448 available from LITEON, capacitor 1416a has a capacitance of 240 pF, resistor 1418a has a resistance of 12 MΩ, transistor 1420a is part no. BC857CL available from Motorola, resistor 1422a has a resistance of 100 kΩ, diode 1424a is part no. RLS4448 available from LITEON, and resistor 1426a has a resistance of 100 kΩ.

The preferred detailed construction of the first and second driver circuits 1500 and 1600 will now be described with reference to FIG. 14. In first driver circuit 1500, the output line 1401a of first touch circuit 1400a is connected to power common line 1107 via a resistor 1510 and also via a capacitor 1512 connected in parallel therewith. The output line 1401a is also connected to the inverting input terminal of an operational amplifier 1514. The non-inverting input terminal of operational amplifier 1514 is connected to line 1502, which runs between first and second driver circuits

1500 and 1600 and is connected to power line 1104 via a resistor 1626. The output of op amp 1514 is connected to power line 1104 via a resistor 1518 and to the input of a Schmitt trigger inverter gate 1516. The output of Schmitt trigger inverter gate 1516 is connected to the input of a second Schmitt trigger inverter gate 1526 via a resistor 1520. A diode 1522 is connected in parallel with resistor 1520 with its cathode connected to the output of inverter gate 1516 and its anode connected to the input of inverter gate 1526 and to power common line 1107 via capacitor 1524. The output of inverter gate 1526 is connected to the base of bipolar PNP switching transistor 1700 via a resistor 1528. The base of transistor 1700 is also connected to power common line 1107 via a capacitor 1532 and to power line 1104 and its emitter via a resistor 1530.

Preferably, resistor 1510 has a resistance of 10 M Ω , capacitor 1512 has a capacitance of 0.01 μ F, op amp comparator 1514 is part no. LM393 available from National Semiconductor, inverter gate 1516 is part no. CD40106B available from Harris, resistor 1518 has a resistance of 10 k Ω , resistor 1520 has a resistance of 1 M Ω , diode 1522 is part no. RLS4448 available from LITEON, capacitor 1524 has a capacitance of 0.22 μ F, inverter gate 1526 is part no. CD40106 available from Harris, resistor 1528 has a resistance of 12 k Ω , resistor 1530 has a resistance of 100 k Ω , capacitor 1532 has a capacitance of 0.01 μ F, and transistor 1700 is part no. MMBTA56L available from Motorola.

In second driver circuit 1600, the output line 1401b of second touch circuit 1400b is connected to power common line 1107 via a resistor 1610 and also via a capacitor 1612 connected in parallel therewith. The output line 1401b is also connected to the inverting input terminal of an operational amplifier 1614. The non-inverting input terminal of operational amplifier 1614 is connected to line 1502, which is connected to power line 1104 via resistor 1626. The non-inverting input terminal of op amp 1614 is also connected to power common line 1107 via a capacitor 1616 and a resistor 1618, which are connected in parallel. The output of op amp 1614 is connected to power line 1104 via a resistor 1630 and to the coupled inputs of a Schmitt trigger inverter gate 1628. The output of op amp 1614 is also connected to its non-inverting input terminal via a resistor 1624. The output of Schmitt trigger inverter NAND gate 1628 is connected to the input of a second Schmitt trigger inverter gate 1638 via a resistor 1632. A diode 1634 is connected in parallel with resistor 1632 with its cathode connected to the output of inverter NAND gate 1628 and its anode connected to the input of inverter NAND gate 1638 and to power common line 1107 via a capacitor 1636. The output of inverter gate 1638 is connected to the base of switching bipolar PNP transistor 1710 via a resistor 1640. The base of transistor 1710 is also connected to power common line 1107 via a capacitor 1642 and to power line 1104 via a resistor 1644. Second driver circuit 1600 also preferably includes capacitors 1620 and 1622 connected in parallel between its connections to power lines 1104 and 1107.

Preferably, resistor 1610 has a resistance of 10 M Ω , capacitor 1612 has a capacitance of 0.01 μ F, op amp comparator 1614 is part no. LM393 available from National Semiconductor, capacitor 1616 has a capacitance of 0.01 μ F, resistor 1618 has a resistance of 20 k Ω , capacitor 1620 has a capacitance of 0.1 μ F, capacitor 1622 has a capacitance of 0.1 μ F, resistor 1624 has a resistance of 100 k Ω , resistor 1626 has a resistance of 10 k Ω , inverter NAND gate 1628 is part no. CD4093B available from Harris, resistor 1630 has a resistance of 10 k Ω , resistor 1632 has a resistance of 1 M Ω , diode 1634 is part no. RLS4448 available from

LITEON, capacitor 1636 has a capacitance of 0.22 μ F, inverter NAND gate 1638 is part no. CD4093B available from Harris, resistor 1640 has a resistance of 12 k Ω , capacitor 1642 has a capacitance of 0.01 μ F, resistor 1644 has a resistance of 100 k Ω , and transistor 1710 is part no. MMBTA56L available from Motorola.

In operation, the output of transistor 1420a (FIG. 13) taken at its collector is rectified by diode 1424a and a DC level is generated by resistors 1426a and 1510 and capacitor 1512 (a DC level of the output of transistor 1420b is generated by resistors 1426b and 1610 and capacitor 1612). When this DC level exceeds the upper threshold voltage of op amp comparator 1514 (1614), the output of schmitt triggered inverter gate 1516 inverter NAND gate 1628 (1628) goes high which charges capacitor 1524 (1636) through resistor 1520 (1632). Gates 1516 and 1526 (1628 and 1638), resistor 1520 (1632), and capacitor 1524 (1636) provide debounce in a conventional manner. Diode 1522 (1634) is used to provide fast release when the palm of the hand is removed from the touch terminal 1450. The output of the debounce circuitry drives transistor 1700 (1710). Resistor 1528 (1640) and capacitor 1532 (1642) are used to filter noise. Both touch circuits must be functional in order to drive the relay switch 1800. Also, if one of the transistors 1700 or 1710 fails, the relay will not be activated.

Relay switch 1800 may be any conventional relay. An example of such a relay is shown in FIG. 14. Relay switch 1800 may include a relay coil 1810 coupled between the selective power supply 1711 of transistors 1700 and 1710 and ground, and a pair of magnetically responsive switches that switch from normally closed terminals 1805 and 1807 to normally open terminals 1801 and 1803 when the relay coil is energized. A zener diode 1815 may be placed in series with a diode 1820 to reduce stress on the relay coil 1810 and to protect transistor 1710 when transistors 1700 and 1710 switch off.

Although the touch circuits of the third embodiment are disclosed as operating a relay switch via driver circuits, it will be appreciated by those skilled in the art that the outputs of touch circuits 1400a and 1400b could be supplied to a microcontroller in the manner discussed above with respect to the first embodiment.

The palm button switch of the present invention uses two redundant touch switch circuits, such as shown in FIG. 12, to disable relay drivers if one of the touch switch circuits fails and redundant relay driver circuitry to turn off a relay switch if one of the driver circuits fails.

Alternatively, the circuitry shown in FIG. 4 could be used. In another embodiment a method to prevent inadvertent actuations is to require a multi-step process. Referring to FIG. 19, a device is shown having a first palm button 2201, a second palm button 2202, and an indicator light 2205. Palm button 2201 has to be activated first and then button 2202 has to be activated within a 2 second time window before a desired actuation can occur. The 90 degree orientation of the two buttons makes it extremely difficult to accidentally touch both with an arm and an elbow or other such physical combination. An added advantage is that the motion required to move the hand from button 2201 to button 2202 can provide some relief from fatigue in the forearm by the resulting muscle flexure that would otherwise not occur if the hand had to be kept near a single button for extended periods of time. A further redundancy can be achieved by requiring simultaneous operation of two such devices, one for each hand. This provides further safeguards against inadvertent actuations and forces the operator to have both hands in a desired safe location once a desired

actuation occurs. A further option is to provide one or more LEDs 2205 or audible annunciators for visual or audible feedback to the operator. Specifically, in FIG. 19 the LED 2205 will come on when button 2201 has been successfully activated to cue the operator that it is time to move to button 2202. Where required a second LED with a different color than the first (yellow for the first LED and red for the second) can be provided to provide visual confirmation that the second button 2202 has been activated or that the required combination of the two buttons has been activated. Two different audible tone or sound generators could also be used in lieu of the LEDs to provide feedback to the operator. In industrial or other challenging settings, the housing is made of high strength polycarbonate (or other high strength non-metallic material) to meet high impact and vibration requirements, preferably NEMA 4. A further option is to provide lighting for the switches to allow operation in the dark.

In a variation of the multi-step process, two touch plates within a housing (one vertical and one horizontal) are used to provide a two-step turn-on. Referring to FIGS. 20A-C, the first step to actuate the output relay 2310, is initiated when the operator inserts his hands and touches the vertical touch sensor 2301 with the dorsal side of the hands. A yellow LED 2304 on top of the device show the successful completion of the first step. The second step is to flip the hand over and touch the horizontal touch sensor 2302 with the palmar side of the hand. A red LED 2305 on top of the device shows the completion of the two step turn-on and activation of output relay 2310. The flipping action of the hand in the second step causes the forearm muscles to flex, thereby reducing stiffness and fatigue. Also, the hands, and arms can rest on the run bar until the machine cycle is complete. The second step of the two-step turn-on must occur within some predetermined time (for example 2 seconds) after the release of vertical touch sensor or the first step must be repeated. In this proposed embodiment, the second step provides an added stimulus and reduces operator errors due to mental and physical fatigue. The top cover prevents actuation of two devices by the use of one hand and elbow of the same arm, as required by ANSI Standard B11.19-1990. The enclosure must be a high strength polycarbonate module to meet the high impact and vibration requirements of the industry, preferably NEMA 4. In both embodiments, high frequency switching is used to desensitize the unit against moisture and contaminants that could generate a path between the button and grounded chassis. The palm button may be formed as the flat palm button shown in FIGS. 15A-C or as a dome-shaped palm button shown in FIG. 16. The button is made of a brass plate 1910 (1930) and can be covered with a plastic or glass 1925 (1933) cover or membrane to desensitize the unit even more against contaminants and other inadvertent actuation. The plastic cover 1925 (1933) acts as a dielectric and capacitance is varied as a function of the area of the plastic being touched. Therefore, if button is touched by finger, a much smaller series capacitance is generated as opposed to button being touched by the palm of a hand. This capacitance is placed in series with the capacitance of the body to ground when the button is touched. Since the capacitance of the body to ground is much larger than the capacitance generated by the button, the functionality of the unit is independent of the variations in body capacitance to ground from person to person. The other factor that needs to be considered here is body resistance. If the button is not covered with an insulator such as plastic, the unit would become sensitive to body resistance. Body resistance to ground, changes as a function of moisture in the work area,

skin dryness, floor structure, and shoes. By using a plastic cover, the unit is made insensitive to variations of body resistance and capacitance. The shape of the button is also a factor in sensitivity. If the button is flat, less of the button area would be covered by the palm of the hand as opposed to a dome shape button that matches the contour of the palm. Therefore, if the button is dome-shaped, the unit can be even more desensitized against inadvertent operation.

By providing a large space for hand insertion and switch activation and a flat or dome shape button where the palm of the hand rests while machine cycle is in process, stress on the forearms is ergonomically reduced. The palm button of the present invention can be activated with or without gloves. The zero force palm button of the present invention may be used to activate electric, pneumatic, air clutch, and hydraulic equipment such as punch presses, molding machines, etc.

As shown in FIGS. 15A-C, the flat palm button may include a plastic housing 1917 having an optional metallic enclosure 1922 for surface mounting. The button also may include a flush mount surface 1915 and optional guarding 1920.

The circuit board 1935 used with the palm button of the present invention may be packaged on two printed circuit boards. One board for power and relay and the other for touch switches and relay drivers. The touch circuit on the touch switch board is interfaced to the button through a screw that also holds the button in place. The power/relay board is interfaced to the touch switch board through a three pin right angle connector. Wiring to the unit is done through a seven position terminal block on the power/relay board. The power/relay board is designed for 24 V DC input power and provides two double-throw relay contacts. However, it can be modified to accommodate different power inputs and switch outputs. For example, a transformer may be added to the power board so that the unit is powered 110VAC/220VAC instead of 24 V DC. Also, the relays may be replaced with other outputs such as digital or 4-20 mA outputs.

The touch circuit components can be integrated in a custom IC 2000, as shown in FIG. 17, to facilitate manufacturing and to reduce cost. Components 413, 412, 414, 410, 418, and 420 are similar to those of circuit 400 shown in FIG. 8. Preferably, resistor 2004 has a resistance of 470 k Ω and diode 2002 has characteristics similar to part no. 1N4148 available from LITEON. Resistors 2008 and 2006 are used to adjust the sensitivity. Diode 2002 at the output of 420, allows the IC to be used in applications where several touch circuit IC's are multiplexed.

As shown in FIG. 18, a sleep circuit 2100 may be added to the oscillator circuit 200 (FIG. 6) to allow microcontroller 600 to turn off the oscillator circuit 200. The disabling of oscillator circuit 200 is done to reduce drainage of capacitor 126 in the regulator circuit 120 during brown outs. The circuit diagram shown in FIG. 18 is a modified version of circuit 200 in FIG. 6. During normal operation microcontroller 600 pulls the input of gate 2116 to ground and causes the output of gate 2116 to go high (power line 104). Therefore, transistor 2110 is biased on and oscillator 200 is functional. When in a sleep mode, microcontroller 600 sources the input to gate 2116 high and causes the output of gate 2116 to go low which turns off transistor 2110 and pulls the input of gate 212 low. Therefore, the oscillator will stop oscillating and drainage on capacitor 126 decreases considerably.

The above described embodiments were chosen for purposes of describing but one application of the present

25

invention. It will be understood by those who practice the invention and by those skilled in the art, that various modifications and improvements may be made to the invention without departing from the spirit or scope of the invention as defined by the appended claims.

The embodiments of the invention in which an exclusive property or privilege is claimed are defined as follows:

1. A capacitive responsive electronic switching circuit comprising:

an oscillator providing a periodic output signal having a frequency of 50 kHz or greater;

an input touch terminal having a dielectric cover defining an area for an operator to provide an input by proximity and touch, an operator's body capacitance to ground as sensed through said input touch terminal varying as a function of the area of said input touch terminal that is proximate the operator's body; and

a detector circuit coupled to said oscillator for receiving said periodic output signal from said oscillator, and coupled to said input touch terminal, said detector circuit being responsive to signals from said oscillator and the presence of an operator's body capacitance to ground coupled to said touch terminal when proximal or touched by an operator to provide a control output signal, wherein said detector circuit includes means for generating said control signal when the sensed body capacitance to ground exceeds a threshold level in order to prevent unintended activation based upon an operator's inadvertent proximity and touch with said input touch terminal.

2. The switching circuit as defined in claim 1, wherein said oscillator provides a periodic output signal having a frequency of 800 kHz or greater.

3. The switching circuit as defined in claim 1 and further including a DC power supply for supplying power to said oscillator and a ground.

4. The switching circuit as defined in claim 1, wherein said periodic output signal provided by said oscillator is a square wave output signal, said oscillator includes a square wave generator for generating a square wave, and a plurality of active elements coupled to an output of said square wave generator to buffer and improve the shape of the square wave output therefrom.

5. The switching circuit as defined in claim 1, wherein said detector circuit includes a microcontroller and a charge pump circuit coupled between said input touch terminal and said microcontroller.

6. The switching circuit as defined in claim 1, wherein said detector circuit includes a microcontroller and a touch circuit coupled between said input touch terminal and said microcontroller.

7. The switching circuit as defined in claim 6 and further including a plurality of said input touch terminals and a plurality of said touch circuits respectively associated with said input touch terminals.

8. The switching circuit as defined in claim 7, wherein said microcontroller selectively applies said periodic output signals received from said oscillator to each of said touch circuits to separately activate each touch circuit.

9. A capacitive responsive electronic switching circuit comprising:

an oscillator providing a periodic output signal having a frequency of 50 kHz or greater;

an input touch terminal defining an area for an operator to provide an input by proximity and touch;

a detector circuit coupled to said oscillator for receiving said periodic output signal from said oscillator, and

26

coupled to said input touch terminal, said detector circuit being responsive to signals from said oscillator and the presence of an operator's body capacitance to ground coupled to said touch terminal when proximal or touched by an operator to provide a control output signal; and

a floating common generator coupled to said oscillator for receiving said square wave output signal, said floating common generator generating a floating common reference for said detector circuit that is set at a fixed voltage below and tracks the square wave output signal.

10. The switching circuit as defined in claim 9, wherein said detector circuit is powered by said square wave output signal provided by said oscillator and by said floating common reference provided by said floating common generator thereby increasing the sensitivity of said detector circuit to proximity and touching of said touch terminal by an operator's body.

11. The switching circuit as defined in claim 10, wherein said detector circuit includes a microcontroller and a charge pump circuit coupled between said input touch terminal and said microcontroller, by an operator's body, wherein said charge pump circuit includes at least one high speed diode coupled between said oscillator and said touch terminal, for enhancing a sensitivity at which said charge pump responds to sensed body capacitance at said touch terminal for higher frequencies.

12. A proximity and touch controlled switching circuit comprising:

an oscillator providing a square wave output signal having a frequency of 50 kHz or greater;

a touch terminal having a dielectric cover defining an input terminal for coupling to an operator's body capacitance to ground; and

a charge pump circuit coupled to said oscillator for receiving said square wave output signal, and coupled to said touch terminal, said charge pump circuit having an output terminal that supplies an output signal having a voltage that varies when said touch terminal is proximal or touched by an operator's body, the voltage of said output signal varies as a function of the area of said touch terminal that is proximal or touched by an operator,

wherein said charge pump circuit includes at least one high speed diode coupled between said oscillator and said touch terminal, for enhancing a sensitivity at which said charge pump responds to sensed body capacitance to ground at said touch terminal for higher frequencies.

13. The proximity and touch controlled circuit as defined in claim 12 and further including a DC power supply for supplying power to said oscillator and a ground.

14. The proximity and touch controlled circuit as defined in claim 12, wherein said oscillator includes a square wave generator for generating a square wave, and a plurality of active elements coupled to an output of said square wave generator to buffer and improve the shape of the square wave output therefrom.

15. The proximity and touch controlled circuit as defined in claim 12, wherein said oscillator provides a periodic output signal having a frequency of 800 kHz or greater.

16. A proximity and touch controlled switching circuit comprising:

an oscillator providing a square wave output signal having a frequency of 50 kHz or greater;

a touch terminal defining an input terminal for coupling to an operator's body capacitance to ground;

27

a charge pump circuit coupled to said oscillator for receiving said square wave output signal, and coupled to said touch terminal, said charge pump circuit having an output terminal that supplies an output signal having a voltage that varies when said touch terminal is proximal or touched by an operator's body; and

a floating common generator coupled to said oscillator for receiving said square wave output signal, said floating common generator generating a floating common reference for said charge pump circuit that is set at a fixed voltage below and tracks said square wave output signal.

wherein said charge pump circuit includes at least one high speed diode coupled between said oscillator and said touch terminal, for enhancing a sensitivity at which said charge pump responds to sensed body capacitance to ground at said touch terminal for higher frequencies.

17. The proximity and touch controlled circuit as defined in claim 16, wherein said charge pump circuit is powered by said square wave output signal provided by said oscillator and by said floating common reference provided by said floating common generator thereby increasing the sensitivity of said charge pump circuit to proximity and touching of said touch terminal by an operator's body.

18. A capacitive responsive electronic switching circuit comprising:

an oscillator providing a periodic output signal having a predefined frequency;

a plurality of input touch terminals defining adjacent areas on a dielectric substrate for an operator to provide inputs by proximity and touch; and

a detector circuit coupled to said oscillator for receiving said periodic output signal from said oscillator, and coupled to said input touch terminals, said detector circuit being responsive to signals from said oscillator and the presence of an operator's body capacitance to ground coupled said touch terminals when proximal or touched by an operator to provide a control output signal.

wherein said predefined frequency of said oscillator is selected to decrease the impedance of said dielectric substrate relative to the impedance of any contaminate that may create an electrical path on said dielectric substrate between said adjacent areas, and wherein said detector circuit compares the sensed body capacitance to ground proximate an input touch terminal to a threshold level to prevent inadvertent generation of the control output signal.

19. The switching circuit as defined in claim 18, wherein said oscillator provides a periodic output signal having a frequency of 800 kHz or greater.

20. A capacitive responsive electronic switching circuit comprising:

an oscillator providing a periodic output signal having a predefined frequency;

a dome-shaped touch terminal defining an area for an operator to provide an input by proximity and touch, wherein the dome shape of the touch terminal is constructed to ergonomically fit the palm of a human hand; and

a detector circuit coupled to said oscillator for receiving said periodic output signal from said oscillator, and coupled to said touch terminal, said detector circuit being responsive to signals from said oscillator and the presence of an operator's body capacitance to ground

28

coupled to said touch terminal when proximal or touched by an operator to provide a control output signal, said detector circuit including means for discriminating between a proximity and touch of said dome-shaped touch terminal by the palm of a human hand and a proximity and touch by a human finger.

21. A capacitive responsive electronic switching circuit comprising:

an oscillator providing a periodic output signal having a predefined frequency;

a touch terminal defining an area for an operator to provide an input by proximity and touch; and

a detector circuit coupled to said oscillator for receiving said periodic output signal from said oscillator, and coupled to said touch terminal, said detector circuit being responsive to signals from said oscillator and the presence of an operator's body capacitance to ground coupled to said touch terminal when proximal or touched by an operator to provide a control output signal, said detector circuit including discriminating means for discriminating between a proximity and touch of said touch terminal covering substantially all of said area of said touch terminal and a proximity and touch covering less than substantially all of said area of said touch terminal.

22. The switching circuit as defined in claim 21, wherein said touch terminal includes a dome-shaped dielectric cover.

23. The switching circuit as defined in claim 21, wherein said touch terminal includes a palm-sized dielectric cover.

24. The switching circuit as defined in claim 23, wherein said discriminating means determines that a proximity and touch of said touch terminal covers substantially all of said area of said touch terminal when said dielectric cover is proximal or touched with the palm of an operator's hand and determines that a proximity or touch covers less than substantially all of said area of said touch terminal when said dielectric cover is proximal or touched with one of an operator's fingers.

25. The switching circuit as defined in claim 21, wherein said discriminating means discriminates between a proximity and touch of said touch terminal covering substantially all of said area of said touch terminal and a proximity and touch covering less than substantially all of said area of said touch terminal based upon a sensed level of body capacitance to ground proximate said touch terminal.

26. The switching circuit as defined in claim 21, wherein said coupling of capacitance to ground occurs when an operator's body is proximate, but not touching, said touch terminal.

27. A capacitive responsive electronic switching circuit for a controlled device comprising:

an oscillator providing a periodic output signal having a predefined frequency;

first and second touch terminals defining areas for an operator to provide an input by proximity and touch; and

a detector circuit coupled to said oscillator for receiving said periodic output signal from said oscillator, and coupled to said first and second touch terminals, said detector circuit being responsive to signals from said oscillator and the presence of an operator's body capacitance to ground coupled to said first and second touch terminals when proximal or touched by an operator to provide a control output signal for actuation of the controlled device, said detector circuit being con-

29

figured to generate said control output signal when said an operator is proximal or touches said second touch terminal after the operator is proximal or touches said first touch terminal.

28. The capacitive responsive electronic switching circuit as defined in claim 27, wherein said detector circuit generates said control signal only when an operator is proximal or touches said second touch terminal within a predetermined time period after the operator is proximal or touches said first touch terminal.

29. The capacitive responsive electronic switching circuit as defined in claim 27, wherein said first and second touch terminals are adapted to be mounted on different surfaces of the controlled device.

30

30. The capacitive responsive electronic switching circuit as defined in claim 27, wherein said first and second touch terminals are adapted to be mounted on non-parallel planar surfaces of the controlled device.

31. The capacitive responsive electronic switching circuit as defined in claim 27, wherein said first and second touch terminals are adapted to be mounted on perpendicular planar surfaces of the controlled device.

32. The capacitive responsive electronic switching circuit as defined in claim 27 and further including an indicator for indicating when said detector circuit determines that an operator is proximal or touches said first touch terminal.

* * * * *

UNITED STATES PATENT AND TRADEMARK OFFICE
CERTIFICATE OF CORRECTION

PATENT NO. : 5,796,183
DATED : August 18, 1998
INVENTOR(S) : Byron Hourmand

Page 1 of 3

It is certified that error appears in the above-identified patent and that said Letters Patent is hereby corrected as shown below:

Column 5, line 52, "such a" should be --such as--.

Column 9, line 31, before "water" insert --condensed--.

Column 14, line 35, "is" should be --as--.

Column 13, line 65, "it's" should be --its--.

Column 18, line 38, "references" should be --reference--.

Column 20, line 7, "it's" should be --its-- (both occurrences).

Column 20, line 9, "it's" should be --its--.

Column 20, line 10, "it's" should be --its-- (both occurrences).

Column 20, line 13, "it's" should be --its--.

Column 20, line 20, "it's" should be --its--.

Column 20, line 39, "it's" should be --its--.

Column 20, line 40, "it's" should be --its--.

Column 20, line 46, "it's" should be --its--.

Column 20, line 47, "it's" should be --its--.

UNITED STATES PATENT AND TRADEMARK OFFICE
CERTIFICATE OF CORRECTION

PATENT NO. : 5,796,183
DATED : August 18, 1998
INVENTOR(S) : Byron Hourmand

Page 2 of 3

It is certified that error appears in the above-identified patent and that said Letters Patent is hereby corrected as shown below:

Column 21, line 8, "it's" should be --its--.

Column 21, line 9, "it's" should be --its--.

Column 21, line 15, "it's" should be --its--.

Column 21, line 42, "it's" should be --its--.

Column 21, line 46, "it's" should be --its--.

Column 21, line 47, "it's" should be --its--.

Column 21, line 56, "it's" should be --its--.

Column 22, line 8, "it's" should be --its--.

Column 22, line 13, "schmitt" should be --Schmitt--.

Column 26, lines 22-27, after "microcontroller." delete "by an operator's body . . . higher frequencies."

UNITED STATES PATENT AND TRADEMARK OFFICE
CERTIFICATE OF CORRECTION

PATENT NO. : 5,796,183
DATED : August 18, 1998
INVENTOR(S) : Byron Hourmand

Page 3 of 3

It is certified that error appears in the above-identified patent and that said Letters Patent is hereby corrected as shown below:

Column 27, line 44, after "electrical" insert "--path--".

Column 27, line 45, delete "path".

Column 29, line 1, after "when" delete "said".

Signed and Sealed this
Eleventh Day of May, 1999

Attest:



Q. TODD DICKINSON

Attesting Officer

Acting Commissioner of Patents and Trademarks

UNITED STATES PATENT AND TRADEMARK OFFICE
CERTIFICATE OF CORRECTION

PATENT NO. : 5,796,183
APPLICATION NO. : 08/601268
DATED : August 18, 1998
INVENTOR(S) : Byron Hourmand et al.

Page 1 of 1

It is certified that error appears in the above-identified patent and that said Letters Patent is hereby corrected as shown below:

Title Page, Item (75) Inventor, should read --(75) Inventors: Byron Hourmand,
Hersey, MI (US); John M. Washeleski, Cadillac, MI (US); Stephen R. W. Cooper,
Fowlerville, MI (US)--.

Signed and Sealed this
Eleventh Day of October, 2011

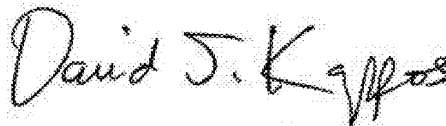

David J. Kappos
Director of the United States Patent and Trademark Office



US005796183C1

(12) **EX PARTE REEXAMINATION CERTIFICATE** (9614th)
United States Patent
Hourmand et al.

(10) **Number:** **US 5,796,183 C1**
(45) **Certificate Issued:** **Apr. 29, 2013**

(54) **CAPACITIVE RESPONSIVE ELECTRONIC SWITCHING CIRCUIT**

(58) **Field of Classification Search**
None
See application file for complete search history.

(75) Inventors: **Byron Hourmand**, Hersey, MI (US);
John M. Washeleski, Cadillac, MI (US);
Stephen R. W. Cooper, Fowlerville, MI (US)

(56) **References Cited**

(73) Assignee: **Nartron Corporation**, Reed City, MI (US)

To view the complete listing of prior art documents cited during the proceeding for Reexamination Control Number 90/012,439, please refer to the USPTO's public Patent Application Information Retrieval (PAIR) system under the Display References tab.

Primary Examiner — Linh M. Nguyen

Reexamination Request:
No. 90/012,439, Aug. 17, 2012

(57) **ABSTRACT**

Reexamination Certificate for:
Patent No.: **5,796,183**
Issued: **Aug. 18, 1998**
Appl. No.: **08/601,268**
Filed: **Jan. 31, 1996**

A capacitive responsive electronic switching circuit comprises an oscillator providing a periodic output signal having a frequency of 50 kHz or greater, an input touch terminal defining an area for an operator provide an input by proximity and touch, and a detector circuit coupled to the oscillator for receiving the periodic output signal from the oscillator, and coupled to the input touch terminal. The detector circuit being responsive to signals from the oscillator and the presence of an operator's body capacitance to ground coupled to the touch terminal when in proximity or touched by an operator to provide a control output signal. Preferably, the oscillator provides a periodic output signal having a frequency of 800 kHz or greater. An array of touch terminals may be provided in close proximity due to the reduction in crosstalk that may result from contaminants by utilizing an oscillator outputting a signal having a frequency of 50 kHz or greater.

Certificate of Correction issued May 11, 1999

Certificate of Correction issued Oct. 11, 2011

(51) **Int. Cl.**
H03K 17/96 (2006.01)
H03K 17/94 (2006.01)
(52) **U.S. Cl.**
USPC **307/116; 307/125; 307/139; 361/181**

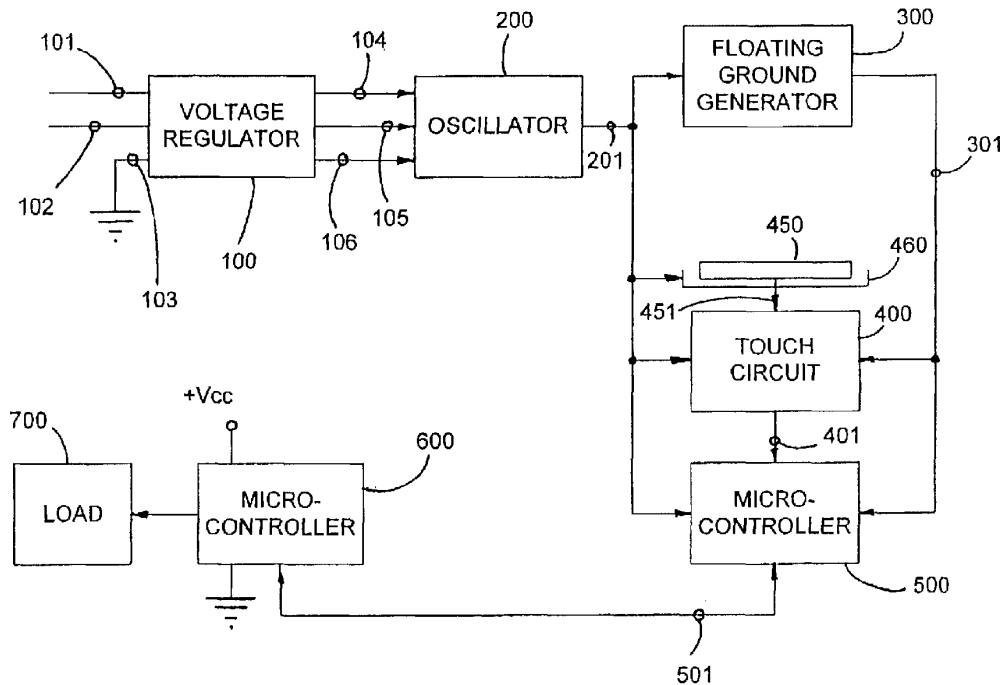

1
EX PARTE
REEXAMINATION CERTIFICATE
ISSUED UNDER 35 U.S.C. 307

THE PATENT IS HEREBY AMENDED AS
INDICATED BELOW.

Matter enclosed in heavy brackets [] appeared in the patent, but has been deleted and is no longer a part of the patent; matter printed in italics indicates additions made to the patent.

AS A RESULT OF REEXAMINATION, IT HAS BEEN DETERMINED THAT:

Claims 18, 27, 28 and 32 are determined to be patentable as amended.

New claims 33-39 are added and determined to be patentable.

Claims 1-17, 19-26 and 29-31 were not reexamined.

18. A capacitive responsive electronic switching circuit comprising:

an oscillator providing a periodic output signal having a predefined frequency;

a microcontroller using the periodic output signal from the oscillator, the microcontroller selectively providing signal output frequencies to a plurality of small sized input touch terminals of a keypad;

[a] the plurality of *small sized* input touch terminals defining adjacent areas on a dielectric substrate for an operator to provide inputs by proximity and touch; and a detector circuit coupled to said oscillator for receiving said periodic output signal from said oscillator, and coupled to said input touch terminals, said detector circuit being responsive to signals from said oscillator via said microcontroller and [the] a presence of an operator's body capacitance to ground coupled to said touch terminals when proximal or touched by [an] the operator to provide a control output signal,

wherein said predefined frequency of said oscillator [is] and said signal output frequencies are selected to decrease [the] a first impedance of said dielectric substrate relative to [the] a second impedance of any contaminate that may create an electrical path on said dielectric substrate between said adjacent areas defined by the plurality of *small sized input touch terminals*, and wherein said detector circuit compares [the] a sensed body capacitance change to ground proximate an input touch terminal to a threshold level to prevent inadvertent generation of the control output signal.

27. A capacitive responsive electronic switching circuit for a controlled keypad device comprising:

an oscillator providing a periodic output signal having a predefined frequency;

a microcontroller using the periodic output signal from the oscillator, the microcontroller selectively providing signal output frequencies to a closely spaced array of input touch terminals of a keypad, the input touch terminals comprising first and second input touch terminals;

the first and second *input touch terminals* defining areas for an operator to provide an input by proximity and touch; and

a detector circuit coupled to said oscillator for receiving said periodic output signal from said oscillator, and coupled to said first and second touch terminals, said

2

detector circuit being responsive to signals from said oscillator via said microcontroller and [the] a presence of an operator's body capacitance to ground coupled to said first and second touch terminals when proximal or touched by [an] the operator to provide a control output signal for actuation of the controlled keypad device, said detector circuit being configured to generate said control output signal when [an] the operator is proximal or touches said second touch terminal after the operator is proximal or touches said first touch terminal.

28. The capacitive responsive electronic switching circuit as defined in claim 27, wherein said detector circuit generates said control signal only when [an] the operator is proximal or touches said second touch terminal within a predetermined time period after the operator is proximal or touches said first touch terminal.

32. The capacitive responsive electronic switching circuit as defined in claim 27 and further including an indicator for indicating when said detector circuit determines that [an] the operator is proximal or touches said first touch terminal.

33. *The capacitive responsive electronic switching circuit as defined in claim 18, further comprising wherein said detector circuit compares the sensed body capacitance change caused by the body capacitance decreasing an input touch terminal signal on the detector to ground when proximate to the input touch terminal to a second threshold level to generate the control output signal.*

34. *The capacitive responsive electronic switching circuit as defined in claim 18, further comprising wherein said detector circuit compares the sensed body capacitance change caused by the body capacitance decreasing an input touch terminal signal amplitude on the detector to ground when proximate to the input touch terminal to a second threshold level to generate the control output signal.*

35. *The capacitive responsive electronic switching circuit as defined in claim 27, wherein when the second touch terminal is not touched on its defining area by the operator to provide input, the control output signal is prevented.*

36. *The capacitive responsive electronic switching circuit as defined in claim 27 and further including an indicator for indicating when said detector circuit determines that the operator is proximal or touches said second touch terminal.*

37. *A capacitive responsive electronic switching circuit for a controlled device comprising:*

an oscillator providing a periodic output signal having a predefined frequency, wherein an oscillator voltage is greater than a supply voltage;

a microcontroller using the periodic output signal from the oscillator, the microcontroller selectively providing signal output frequencies to a closely spaced array of input touch terminals of a keypad, the input touch terminals comprising first and second input touch terminals;

the first and second touch terminals defining areas for an operator to provide an input by proximity and touch; and a detector circuit coupled to said oscillator for receiving said periodic output signal from said oscillator, and

coupled to said first and second touch terminals, said detector circuit being responsive to signals from said oscillator via said microcontroller and a presence of an operator's body capacitance to ground coupled to said first and second touch terminals when proximal or touched by the operator to provide a control output signal for actuation of the controlled device, said detector circuit being configured to generate said control output signal when the operator is proximal or touches said second touch terminal after the operator is proximal or touches said first touch terminal.

3

4

38. The capacitive responsive electronic switching circuit as defined in claim 37, wherein feedback to the operator is provided by an indicator activated by the microcontroller after the operator touches the second touch terminal.

39. The capacitive responsive electronic switching circuit 5 as defined in claim 37,

wherein said detector circuit compares a sensed body capacitance change caused by the body capacitance decreasing a second touch terminal signal on the detector to ground when proximate to the second touch terminal to a threshold level to generate the control output signal, and

wherein feedback to the operator is provided by an indicator activated by the microcontroller after the operator touches the second touch terminal. 15

* * * * *

STATEMENT UNDER 37 CFR 3.73(c)Applicant/Patent Owner: Byron HourmandApplication No./Patent No.: 5,796,183 B1 Filed/Issue Date: August 18, 1998Titled: Capacitive Responsive Electronic Switching Circuit

UUSI, LLC, a Corporation

(Name of Assignee)

(Type of Assignee, e.g., corporation, partnership, university, government agency, etc.)

states that, for the patent application/patent identified above, it is (choose **one** of options 1, 2, 3 or 4 below):

1. The assignee of the entire right, title, and interest.
2. An assignee of less than the entire right, title, and interest (check applicable box):
- The extent (by percentage) of its ownership interest is _____%. Additional Statement(s) by the owners holding the balance of the interest must be submitted to account for 100% of the ownership interest.
- There are unspecified percentages of ownership. The other parties, including inventors, who together own the entire right, title and interest are:

Additional Statement(s) by the owner(s) holding the balance of the interest must be submitted to account for the entire right, title, and interest.

3. The assignee of an undivided interest in the entirety (a complete assignment from one of the joint inventors was made). The other parties, including inventors, who together own the entire right, title, and interest are:

Additional Statement(s) by the owner(s) holding the balance of the interest must be submitted to account for the entire right, title, and interest.

4. The recipient, via a court proceeding or the like (e.g., bankruptcy, probate), of an undivided interest in the entirety (a complete transfer of ownership interest was made). The certified document(s) showing the transfer is attached.

The interest identified in option 1, 2 or 3 above (not option 4) is evidenced by either (choose **one** of options A or B below):

- A. An assignment from the inventor(s) of the patent application/patent identified above. The assignment was recorded in the United States Patent and Trademark Office at Reel _____, Frame _____, or for which a copy thereof is attached.
- B. A chain of title from the inventor(s), of the patent application/patent identified above, to the current assignee as follows:

1. From: Byron Hourmand To: Nartron CorporationThe document was recorded in the United States Patent and Trademark Office at Reel 008254, Frame 0496, or for which a copy thereof is attached.2. From: Byron Hourmand To: Nartron CorporationThe document was recorded in the United States Patent and Trademark Office at Reel 008443, Frame 0749, or for which a copy thereof is attached.

[Page 1 of 2]

This collection of information is required by 37 CFR 3.73(b). The information is required to obtain or retain a benefit by the public which is to file (and by the USPTO to process) an application. Confidentiality is governed by 35 U.S.C. 122 and 37 CFR 1.11 and 1.14. This collection is estimated to take 12 minutes to complete, including gathering, preparing, and submitting the completed application form to the USPTO. Time will vary depending upon the individual case. Any comments on the amount of time you require to complete this form and/or suggestions for reducing this burden, should be sent to the Chief Information Officer, U.S. Patent and Trademark Office, U.S. Department of Commerce, P.O. Box 1450, Alexandria, VA 22313-1450. DO NOT SEND FEES OR COMPLETED FORMS TO THIS ADDRESS. **SEND TO: Commissioner for Patents, P.O. Box 1450, Alexandria, VA 22313-1450**

If you need assistance in completing the form, call 1-800-PTO-9199 and select option 2.

STATEMENT UNDER 37 CFR 3.73(c)

3. From: John M. Washeleski To: Nartron Corporation

The document was recorded in the United States Patent and Trademark Office at
Reel 028804, Frame 0075, or for which a copy thereof is attached.

4. From: Stephen R.W. Cooper To: Nartron Corporation

The document was recorded in the United States Patent and Trademark Office at
Reel 028804, Frame 0137, or for which a copy thereof is attached.

5. From: Nartron Corporation To: UUSI, LLC

The document was recorded in the United States Patent and Trademark Office at
Reel 023679, Frame 0803, or for which a copy thereof is attached.

6. From: _____ To: _____

The document was recorded in the United States Patent and Trademark Office at
Reel _____, Frame _____, or for which a copy thereof is attached.

Additional documents in the chain of title are listed on a supplemental sheet(s).

As required by 37 CFR 3.73(c)(1)(i), the documentary evidence of the chain of title from the original owner to the assignee was, or concurrently is being, submitted for recordation pursuant to 37 CFR 3.11.

[NOTE: A separate copy (i.e., a true copy of the original assignment document(s)) must be submitted to Assignment Division in accordance with 37 CFR Part 3, to record the assignment in the records of the USPTO. See MPEP 302.08]

The undersigned (whose title is supplied below) is authorized to act on behalf of the assignee.

/Brian A. Carlson/

December 24, 2013

Signature

Date

Brian A. Carlson

37,793

Printed or Typed Name

Title or Registration Number

Privacy Act Statement

The **Privacy Act of 1974 (P.L. 93-579)** requires that you be given certain information in connection with your submission of the attached form related to a patent application or patent. Accordingly, pursuant to the requirements of the Act, please be advised that: (1) the general authority for the collection of this information is 35 U.S.C. 2(b)(2); (2) furnishing of the information solicited is voluntary; and (3) the principal purpose for which the information is used by the U.S. Patent and Trademark Office is to process and/or examine your submission related to a patent application or patent. If you do not furnish the requested information, the U.S. Patent and Trademark Office may not be able to process and/or examine your submission, which may result in termination of proceedings or abandonment of the application or expiration of the patent.

The information provided by you in this form will be subject to the following routine uses:

1. The information on this form will be treated confidentially to the extent allowed under the Freedom of Information Act (5 U.S.C. 552) and the Privacy Act (5 U.S.C. 552a). Records from this system of records may be disclosed to the Department of Justice to determine whether disclosure of these records is required by the Freedom of Information Act.
2. A record from this system of records may be disclosed, as a routine use, in the course of presenting evidence to a court, magistrate, or administrative tribunal, including disclosures to opposing counsel in the course of settlement negotiations.
3. A record in this system of records may be disclosed, as a routine use, to a Member of Congress submitting a request involving an individual, to whom the record pertains, when the individual has requested assistance from the Member with respect to the subject matter of the record.
4. A record in this system of records may be disclosed, as a routine use, to a contractor of the Agency having need for the information in order to perform a contract. Recipients of information shall be required to comply with the requirements of the Privacy Act of 1974, as amended, pursuant to 5 U.S.C. 552a(m).
5. A record related to an International Application filed under the Patent Cooperation Treaty in this system of records may be disclosed, as a routine use, to the International Bureau of the World Intellectual Property Organization, pursuant to the Patent Cooperation Treaty.
6. A record in this system of records may be disclosed, as a routine use, to another federal agency for purposes of National Security review (35 U.S.C. 181) and for review pursuant to the Atomic Energy Act (42 U.S.C. 218(c)).
7. A record from this system of records may be disclosed, as a routine use, to the Administrator, General Services, or his/her designee, during an inspection of records conducted by GSA as part of that agency's responsibility to recommend improvements in records management practices and programs, under authority of 44 U.S.C. 2904 and 2906. Such disclosure shall be made in accordance with the GSA regulations governing inspection of records for this purpose, and any other relevant (*i.e.*, GSA or Commerce) directive. Such disclosure shall not be used to make determinations about individuals.
8. A record from this system of records may be disclosed, as a routine use, to the public after either publication of the application pursuant to 35 U.S.C. 122(b) or issuance of a patent pursuant to 35 U.S.C. 151. Further, a record may be disclosed, subject to the limitations of 37 CFR 1.14, as a routine use, to the public if the record was filed in an application which became abandoned or in which the proceedings were terminated and which application is referenced by either a published application, an application open to public inspection or an issued patent.
9. A record from this system of records may be disclosed, as a routine use, to a Federal, State, or local law enforcement agency, if the USPTO becomes aware of a violation or potential violation of law or regulation.

Under the Paperwork Reduction Act of 1995, no persons are required to respond to a collection of information unless it displays a valid OMB control number.

POWER OF ATTORNEY TO PROSECUTE APPLICATIONS BEFORE THE USPTO

I hereby revoke all previous powers of attorney given in the application identified in the attached statement under 37 CFR 3.73(b).

I hereby appoint:

Practitioners associated with the Customer Number: 25962

OR

Practitioner(s) named below (if more than ten patent practitioners are to be named, then a customer number must be used):

Name	Registration Number	Name	Registration Number

as attorney(s) or agent(s) to represent the undersigned before the United States Patent and Trademark Office (USPTO) in connection with any and all patent applications assigned only to the undersigned according to the USPTO assignment records or assignment documents attached to this form in accordance with 37 CFR 3.73(b).

Please change the correspondence address for the application identified in the attached statement under 37 CFR 3.73(b) to:

The address associated with Customer Number: 25962

OR

<input type="checkbox"/> Firm or Individual Name			
Address			
City	State	Zip	
Country			
Telephone	Email		

Assignee Name and Address:

UUSI, LLC
 5000 North US Highway 131, Twenty-Second Floor
 Reed City, Michigan 49677

A copy of this form, together with a statement under 37 CFR 3.73(b) (Form PTO/SB/96 or equivalent) is required to be filed in each application in which this form is used. The statement under 37 CFR 3.73(b) may be completed by one of the practitioners appointed in this form if the appointed practitioner is authorized to act on behalf of the assignee, and must identify the application in which this Power of Attorney is to be filed.

SIGNATURE of Assignee of Record

The individual whose signature and title is supplied below is authorized to act on behalf of the assignee

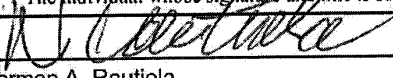
Signature		Date	9-26-12
Name	Norman A. Rautiola	Telephone	231-832-5525
Title	Manager		

This collection of information is required by 37 CFR 1.31, 1.32 and 1.33. The information is required to obtain or retain a benefit by the public which is to file (and by the USPTO to process) an application. Confidentiality is governed by 35 U.S.C. 122 and 37 CFR 1.11 and 1.14. This collection is estimated to take 3 minutes to complete, including gathering, preparing, and submitting the completed application form to the USPTO. Time will vary depending upon the individual case. Any comments on the amount of time you require to complete this form and/or suggestions for reducing this burden, should be sent to the Chief Information Officer, U.S. Patent and Trademark Office, U.S. Department of Commerce, P.O. Box 1450, Alexandria, VA 22313-1450. DO NOT SEND FEES OR COMPLETED FORMS TO THIS ADDRESS. SEND TO: Commissioner for Patents, P.O. Box 1450, Alexandria, VA 22313-1450.

If you need assistance in completing the form, call 1-800-PTO-9199 and select option 2.

IN THE UNITED STATES PATENT AND TRADEMARK OFFICE

U.S. Patent No.: 5,796,183 B1 § Docket No.: 5796183RX2
Issued: August 18, 1998 § Inventors: Hourmand et al.
Filed: January 31, 1996 § Patent Owner: UUSI, LLC
Control No. TBD § Examiner: TBD
For: Capacitive Responsive Electronic Switching Circuit

Commissioner for Patents
P.O. Box 1450
Alexandria, VA 22313-1450

INFORMATION DISCLOSURE STATEMENT

Dear Sir:

Patent Owner wishes to bring to the attention of the U.S. Patent and Trademark Office the information noted on the enclosed form, which may be considered material to the reexamination of the above-identified patent. Patent Owner makes no assertion that a prior art search has been made or that any of the cited references are prior art under 35 U.S.C. § 102. In some instances, publications that are not prior art under 35 U.S.C. § 102 have been cited as they may discuss prior art systems and may provide insight into the state of the art at the time of the invention.

Respectfully submitted,

December 24, 2013
Date

/Brian A. Carlson/
Brian A. Carlson
Reg. No. 37,793

SLATER & MATSIL, L.L.P.
17950 Preston Rd., Ste. 1000
Dallas, Texas 75252
Tel.: 972-732-1001
docketing@slater-matsil.com

INFORMATION DISCLOSURE STATEMENT BY APPLICANT (Not for submission under 37 CFR 1.99)	Application Number		
	Filing Date		
	First Named Inventor	Byron Hourmand	
	Art Unit		
	Examiner Name		
	Attorney Docket Number	5796183RX	

U.S.PATENTS							Remove	
Examiner Initial*	Cite No	Patent Number	Kind Code ¹	Issue Date	Name of Patentee or Applicant of cited Document	Pages,Columns,Lines where Relevant Passages or Relevant Figures Appear		
	1	4766368		1988-08-23	Cox			
	2	4825385		1989-04-25	Dolph, et al.			
	3	5305017		1994-04-19	Gerpheide			
	4	5337353		1994-08-09	Boie, et al.			
	5	5463388		1995-10-31	Boie, et al.			
	6	5565658		1996-10-15	Gerpheide, et al.			
If you wish to add additional U.S. Patent citation information please click the Add button.							Add	
U.S.PATENT APPLICATION PUBLICATIONS							Remove	
Examiner Initial*	Cite No	Publication Number	Kind Code ¹	Publication Date	Name of Patentee or Applicant of cited Document	Pages,Columns,Lines where Relevant Passages or Relevant Figures Appear		

INFORMATION DISCLOSURE STATEMENT BY APPLICANT (Not for submission under 37 CFR 1.99)	Application Number			
	Filing Date			
	First Named Inventor	Byron Hourmand		
	Art Unit			
	Examiner Name			
	Attorney Docket Number		5796183RX	

	1						
--	---	--	--	--	--	--	--

If you wish to add additional U.S. Published Application citation information please click the Add button. **Add**

FOREIGN PATENT DOCUMENTS

Remove

Examiner Initial*	Cite No	Foreign Document Number ³	Country Code ² j	Kind Code ⁴	Publication Date	Name of Patentee or Applicant of cited Document	Pages, Columns, Lines where Relevant Passages or Relevant Figures Appear	T ⁵
	1							<input type="checkbox"/>

If you wish to add additional Foreign Patent Document citation information please click the Add button. **Add**

NON-PATENT LITERATURE DOCUMENTS

Remove

Examiner Initials*	Cite No	Include name of the author (in CAPITAL LETTERS), title of the article (when appropriate), title of the item (book, magazine, journal, serial, symposium, catalog, etc), date, pages(s), volume-issue number(s), publisher, city and/or country where published.	T ⁵
	1	BUXTON, B., "31.1: Invited Paper: A Touching Story: A Personal Perspective on the History of Touch Interfaces Past and Future," Society for Information Display (SID) Symposium Digest of Technical Papers, Vol. 41, No. 1, Session 31, May 2010, pp. 444-448.	<input type="checkbox"/>
	2	HINCKLEY, K., et al., "38.2: Direct Display Interaction via Simultaneous Pen + Multi-touch Input," Society for Information Display (SID) Symposium Digest of Technical Papers, Vol. 41, No. 1, Session 38, May 2010, pp. 537-540.	<input type="checkbox"/>
	3	LEE, S., "A Fast Multiple-Touch-Sensitive Input Device," University of Toronto, Department of Electrical Engineering, Master Thesis, October 1984, 118 pages.	<input type="checkbox"/>
	4	HILLIS, W.D., "A High-Resolution Imaging Touch Sensor," The International Journal of Robotics Research, Vol. 1, No. 2, Summer (June - Aug.) 1982, pp. 33-44.	<input type="checkbox"/>
	5	LEE, S.K., et al., "A Multi-Touch Three Dimensional Touch-Sensitive Tablet," Proceedings of the SIGCHI Conference on Human Factors in Computing Systems, April 1985, pp. 21-25.	<input type="checkbox"/>

INFORMATION DISCLOSURE STATEMENT BY APPLICANT (Not for submission under 37 CFR 1.99)	Application Number		
	Filing Date		
	First Named Inventor	Byron Hourmand	
	Art Unit		
	Examiner Name		
	Attorney Docket Number	5796183RX	

6	HLADY, A.M., "A touch sensitive X-Y position encoder for computer input," Proceedings of the Fall Joint Computer Conference, November 18-20, 1969, pp. 545-551.	<input type="checkbox"/>
7	SASAKI, L., et al., "A Touch-Sensitive Input Device," International Computer Music Conference Proceedings, November 1981, pp. 293-296.	<input type="checkbox"/>
8	CALLAHAN, J., et al., "An Empirical Comparison of Pie vs. Linear Menus," Human Factors in Computing Systems: Chicago '88 Conference Proceedings: May 15-19, 1988, Washington DC: Special Issue of the SIGCHI Bulletin, New York, Association for Computing Machinery, pp. 95-100.	<input type="checkbox"/>
9	CASIO, AT-550 Advertisement, published in Popular Science by On The Run, February 1984, p.-129.	<input type="checkbox"/>
10	CASIO, "Module No. 320," AT-550 Owner's Manual, at least as early as December 1984, 14 pages.	<input type="checkbox"/>
11	SMITH, S.D., et al., "Bit-slice microprocessors in h.f. digital communications," The Radio and Electronic Engineer, Vol. 51, No. 6, June 1981, pp. 299-301.	<input type="checkbox"/>
12	BOIE, R.A., "Capacitive Impedance Readout Tactile Image Sensor," Proceedings of the IEEE International Conference on Robotics and Automation, Vol. 1, March 1984, pp. 370-372.	<input type="checkbox"/>
13	THOMPSON, C., "Clive Thompson on The Breakthrough Myth," Wired Magazine, http://www.wired.com/magazine/2011/07/st_thompson_breakthrough , August 2011, 3 pages.	<input type="checkbox"/>
14	"Innovation in Information Technology," National Research Council of the National Academies, Computer Science and Telecommunications Board, Division on Engineering and Physical Sciences, http://www.nap.edu/catalog/10795.html , 2003, 85 pages.	<input type="checkbox"/>
15	BUXTON, W., et al., "Issues and Techniques in Touch-Sensitive Tablet Input," Proceedings of SIGGRAPH '85, Vol. 19, No. 3, July 22-26, 1985, pp. 215-223.	<input type="checkbox"/>
16	BUXTON, W., et al., "Large Displays in Automotive Design," IEEE Computer Graphics and Applications, July/August 2000, pp. 68-75.	<input type="checkbox"/>

INFORMATION DISCLOSURE STATEMENT BY APPLICANT (Not for submission under 37 CFR 1.99)	Application Number		
	Filing Date		
	First Named Inventor	Byron Hourmand	
	Art Unit		
	Examiner Name		
	Attorney Docket Number	5796183RX	

17	BUXTON, W., "Lexical and Pragmatic Considerations of Input Structures," ACM SIGGRAPH Computer Graphics, Vol. 17, No. 1, January 1983, pp. 31-37.	<input type="checkbox"/>
18	BETTS, P., et al., "Light Beam Matrix Input Terminal," IBM Technical Disclosure Bulletin, October 1966, pp. 493-494.	<input type="checkbox"/>
19	BUXTON, B., "Multi-Touch Systems that I Have Known and Loved," downloaded from http://www.billbuxton.com/multitouchOverview.html , January 12, 2007, 22 pages.	<input type="checkbox"/>
20	HEROT, C.F., et al., "One-Point Touch Input of Vector Information for Computer Displays," Proceedings of the 5th Annual Conference on Computer Graphics and Interactive Techniques, August 23-25, 1978, pp. 210-216.	<input type="checkbox"/>
21	WOLFELD, J.A., "Real Time Control of a Robot Tactile Sensor," University of Pennsylvania, Department of Computer & Information Science, Technical Reports (CIS), Master Thesis, http://repository.upenn.edu/cis-reports/678 , August 1981, 68 pages.	<input type="checkbox"/>
22	LEWIS, J.R., "Reaping the Benefits of Modern Usability Evaluation: The Simon Story," Advances in Applied Ergonomics: Proceedings of the 1st International Conference on Applied Ergonomics, ICAE May 21-24, 1996, pp. 752-755.	<input type="checkbox"/>
23	NAKATANI, L.H., et al., "Soft Machines: A Philosophy of User-Computer Interface Design," Proceedings of the SIGCHI Conference on Human Factors in Computing Systems, December 1983, Chicago, pp. 19-23.	<input type="checkbox"/>
24	RUBINE, D.H., "The Automatic Recognition of Gestures," Carnegie Mellon University, Master Thesis, CMU-CS-91-202, December, 1991, 285 pages.	<input type="checkbox"/>
25	KURTENBACH, G.P., "The Design and Evaluation of Marking Menus," University of Toronto, Graduate Department of Computer Science, Master Thesis, May 1993, 201 pages.	<input type="checkbox"/>
26	HOPKINS, D., "The Design and Implementation of Pie Menus," originally published in Dr. Dobb's Journal, December 1991, lead cover story, user interface issue, reproduced at www.DonHopkins.com , 8 pages.	<input type="checkbox"/>
27	BUXTON, B., "The Long Nose of Innovation," Bloomberg Businessweek, Innovation & Design, January 2, 2008, 3 pages, downloaded from: http://www.businessweek.com/stories/2008-01-02/the-long-nose-of-innovationbusinessweek-business-news-stock-market-and-financialadvice .	<input type="checkbox"/>

INFORMATION DISCLOSURE STATEMENT BY APPLICANT (Not for submission under 37 CFR 1.99)	Application Number		
	Filing Date		
	First Named Inventor	Byron Hourmand	
	Art Unit		
	Examiner Name		
	Attorney Docket Number	5796183RX	

28	BUXTON, B., "The Mad Dash Toward Touch Technology," Bloomberg Businessweek, Innovation & Design, October 21, 2009, 3 pages, downloaded from: http://www.businessweek.com/innovate/content/oct2009/id20091021_629186.htm .	<input type="checkbox"/>
29	"The Sensor Frame Graphic Manipulator," NASA Phase II Final Report, NASA-CR-194243, May 8, 1992, 28 pages.	<input type="checkbox"/>
30	IZADI, S., et al., "ThinSight: A Thin Form-Factor Interactive Surface Technology," Communications of the ACM, Research Highlights, Vol. 52, No. 12, December 2009, pp. 90-98.	<input type="checkbox"/>
31	KRUEGER, M.W., et al., "VIDEOPACE - An Artificial Reality," Proceedings of the SIGCHI Conference on Human Factors in Computing Systems, April 1985, pp. 35-40.	<input type="checkbox"/>
32	BROWN, E., et al., "Windows on Tablets as a Means of Achieving Virtual Input Devices," Proceedings of the IFIP TC13 Third International Conference on Human-Computer Interaction, August 27-31, 1990, in D. Diaper, et al. (Eds), Human-Computer Interaction - INTERACT '90, Amsterdam: Elsevier Science Publishers B.V. (North Holland), 11 pages.	<input type="checkbox"/>
33	"A Multi-Touch Three Dimensional Touch-Sensitive Tablet," http://www.youtube.com/watch?v=Arrus9CxUiA , November 18, 2009, 1 page.	<input type="checkbox"/>
34	"Casio AT-550 Touch Screen Calculator Watch (1984)," http://www.youtube.com/watch?v=UhVAsqhfhqU , May 24, 2012, 1 page.	<input type="checkbox"/>

If you wish to add additional non-patent literature document citation information please click the Add button **Add**

EXAMINER SIGNATURE

Examiner Signature		Date Considered	
--------------------	--	-----------------	--

*EXAMINER: Initial if reference considered, whether or not citation is in conformance with MPEP 609. Draw line through a citation if not in conformance and not considered. Include copy of this form with next communication to applicant.

¹ See Kind Codes of USPTO Patent Documents at www.USPTO.GOV or MPEP 901.04. ² Enter office that issued the document, by the two-letter code (WIPO Standard ST.3). ³ For Japanese patent documents, the indication of the year of the reign of the Emperor must precede the serial number of the patent document. ⁴ Kind of document by the appropriate symbols as indicated on the document under WIPO Standard ST.16 if possible. ⁵ Applicant is to place a check mark here if English language translation is attached.

INFORMATION DISCLOSURE STATEMENT BY APPLICANT (Not for submission under 37 CFR 1.99)	Application Number		
	Filing Date		
	First Named Inventor	Byron Hourmand	
	Art Unit		
	Examiner Name		
	Attorney Docket Number	5796183RX	

CERTIFICATION STATEMENT

Please see 37 CFR 1.97 and 1.98 to make the appropriate selection(s):

That each item of information contained in the information disclosure statement was first cited in any communication from a foreign patent office in a counterpart foreign application not more than three months prior to the filing of the information disclosure statement. See 37 CFR 1.97(e)(1).

OR

That no item of information contained in the information disclosure statement was cited in a communication from a foreign patent office in a counterpart foreign application, and, to the knowledge of the person signing the certification after making reasonable inquiry, no item of information contained in the information disclosure statement was known to any individual designated in 37 CFR 1.56(c) more than three months prior to the filing of the information disclosure statement. See 37 CFR 1.97(e)(2).

See attached certification statement.

The fee set forth in 37 CFR 1.17 (p) has been submitted herewith.

A certification statement is not submitted herewith.

SIGNATURE

A signature of the applicant or representative is required in accordance with CFR 1.33, 10.18. Please see CFR 1.4(d) for the form of the signature.

Signature	/Brian A. Carlson/	Date (YYYY-MM-DD)	2013-12-24
Name/Print	Brian A. Carlson	Registration Number	37,793

This collection of information is required by 37 CFR 1.97 and 1.98. The information is required to obtain or retain a benefit by the public which is to file (and by the USPTO to process) an application. Confidentiality is governed by 35 U.S.C. 122 and 37 CFR 1.14. This collection is estimated to take 1 hour to complete, including gathering, preparing and submitting the completed application form to the USPTO. Time will vary depending upon the individual case. Any comments on the amount of time you require to complete this form and/or suggestions for reducing this burden, should be sent to the Chief Information Officer, U.S. Patent and Trademark Office, U.S. Department of Commerce, P.O. Box 1450, Alexandria, VA 22313-1450. **DO NOT SEND FEES OR COMPLETED FORMS TO THIS ADDRESS. SEND TO: Commissioner for Patents, P.O. Box 1450, Alexandria, VA 22313-1450.**

Privacy Act Statement

The Privacy Act of 1974 (P.L. 93-579) requires that you be given certain information in connection with your submission of the attached form related to a patent application or patent. Accordingly, pursuant to the requirements of the Act, please be advised that: (1) the general authority for the collection of this information is 35 U.S.C. 2(b)(2); (2) furnishing of the information solicited is voluntary; and (3) the principal purpose for which the information is used by the U.S. Patent and Trademark Office is to process and/or examine your submission related to a patent application or patent. If you do not furnish the requested information, the U.S. Patent and Trademark Office may not be able to process and/or examine your submission, which may result in termination of proceedings or abandonment of the application or expiration of the patent.

The information provided by you in this form will be subject to the following routine uses:

1. The information on this form will be treated confidentially to the extent allowed under the Freedom of Information Act (5 U.S.C. 552) and the Privacy Act (5 U.S.C. 552a). Records from this system of records may be disclosed to the Department of Justice to determine whether the Freedom of Information Act requires disclosure of these records.
2. A record from this system of records may be disclosed, as a routine use, in the course of presenting evidence to a court, magistrate, or administrative tribunal, including disclosures to opposing counsel in the course of settlement negotiations.
3. A record in this system of records may be disclosed, as a routine use, to a Member of Congress submitting a request involving an individual, to whom the record pertains, when the individual has requested assistance from the Member with respect to the subject matter of the record.
4. A record in this system of records may be disclosed, as a routine use, to a contractor of the Agency having need for the information in order to perform a contract. Recipients of information shall be required to comply with the requirements of the Privacy Act of 1974, as amended, pursuant to 5 U.S.C. 552a(m).
5. A record related to an International Application filed under the Patent Cooperation Treaty in this system of records may be disclosed, as a routine use, to the International Bureau of the World Intellectual Property Organization, pursuant to the Patent Cooperation Treaty.
6. A record in this system of records may be disclosed, as a routine use, to another federal agency for purposes of National Security review (35 U.S.C. 181) and for review pursuant to the Atomic Energy Act (42 U.S.C. 218(c)).
7. A record from this system of records may be disclosed, as a routine use, to the Administrator, General Services, or his/her designee, during an inspection of records conducted by GSA as part of that agency's responsibility to recommend improvements in records management practices and programs, under authority of 44 U.S.C. 2904 and 2906. Such disclosure shall be made in accordance with the GSA regulations governing inspection of records for this purpose, and any other relevant (i.e., GSA or Commerce) directive. Such disclosure shall not be used to make determinations about individuals.
8. A record from this system of records may be disclosed, as a routine use, to the public after either publication of the application pursuant to 35 U.S.C. 122(b) or issuance of a patent pursuant to 35 U.S.C. 151. Further, a record may be disclosed, subject to the limitations of 37 CFR 1.14, as a routine use, to the public if the record was filed in an application which became abandoned or in which the proceedings were terminated and which application is referenced by either a published application, an application open to public inspections or an issued patent.
9. A record from this system of records may be disclosed, as a routine use, to a Federal, State, or local law enforcement agency, if the USPTO becomes aware of a violation or potential violation of law or regulation.

31.1: Invited Paper: A Touching Story: A Personal Perspective on the History of Touch Interfaces Past and Future

Bill Buxton

Microsoft Research, One Microsoft Way, Redmond, WA, USA

Abstract

Touch screens have a 40+ year history. Multi-touch and some of the gestures associated with it, are over 25 years old. This paper aspires to provide some perspective on the roots of these technologies, and share some future-relevant insights from those experiences. Since the scope of the article does not permit a comprehensive survey, emphasis has been given to projects and insights that are relevant, but less-well known.

1. Introduction

The announcement of two new products in 2007, the Apple *iPhone* and Microsoft *Surface*, gave a serious boost to interest in touch interfaces – especially those that incorporate multi-touch. Since then, touch, multi-touch, and the gesture-based interfaces that they frequently employ, have become close to “must-have” features in several market segments, including mobile devices, desktop computers, laptops, and large format displays.

What is typically missed amongst this newfound interest – but also typical of virtually all “new” technologies – is how far back these techniques and technologies go [1][2]. For example, the use of touch input as a means to interact with computers began, at least, in the mid-1960s, with early work being done by IBM [3] in Ottawa Canada[4], and the University of Illinois [5]. By the early 1970s, a number of different technologies had been disclosed.

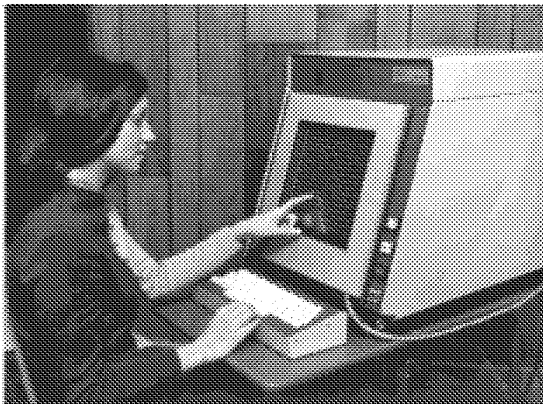

Figure 1: PLATO IV Terminal with touch screen and plasma panel display. (Courtesy of Archives of the University of Illinois, Urban Champaign. Found in RS: 39/2/20, Box COL 13, Folder COL 13-13 Computer Ed. Research Lab / PLATO 1952-74)

By 1972, touch screens had left the labs and computer centers and entered selected grade-school classrooms as part of the PLATO IV system, illustrated in Figure 1. This was all the more remarkable when one considers that PLATO IV not only preceded the appearance of the personal computer and local area networks, its relatively wide deployment happened when Xerox PARC was just starting work on the Alto computer!

Through the 1970s-80s a number of different technologies were

developed to support touch (such as capacitive, resistive, light interruption, and surface acoustic wave), and a number of different companies were founded to commercialize these technologies. Examples include, Elographics, Carroll Touch, and MicroTouch Systems.

As the options for the interface designer grew, so did the granularity of our understanding of the affordances of the available technologies and techniques. Nakatani and Rohrlich [6], for example, gave voice to the notion of “soft machines”, what they defined as:

--- using the synergistic combination of real-time computer graphics to display “soft controls,” and a touch screen to make soft controls operable like conventional hard controls.

However, as Gustave Flaubert said, “God is in the details,” and getting the details wrong could make a good technology look really bad – as was the case with how cursor control was implemented on the early Apollo workstations, using an Elographics touchpad.

2. Lost Along the Way

From the time of PLATO IV to close to 2000, the use of touch-sensing screens and tablets settled into a number or more-or-less niche markets. Touchpads/tablets (touch sensors not mounted directly over a display) became most visible on laptops, where they were (and are) the dominant technology used for cursor control. Touch screens were largely split into three main segments, kiosks (including ATM machines), point-of-sale devices (restaurants and retail, for example), and mobile devices (starting with PDAs, but as early as 1993 – as we shall discuss – mobile phones).

Many of these markets were not very demanding in terms of the richness of the interaction techniques employed. Kiosks, for example, adopted mainly simple touch-to-select operations. At the same time, however, there was remarkable work which is not well-known, and hence worth highlighting.

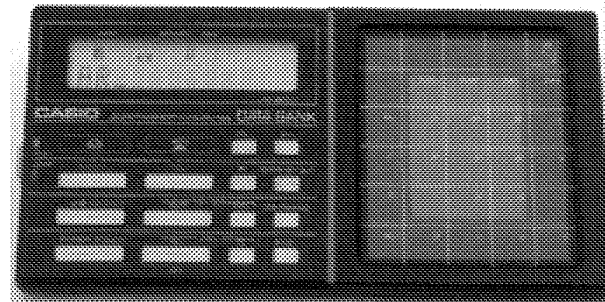

Figure 2: The PF-8000 Data Bank (1984). Characters can be entered by printing them on the touchpad with a finger.

Take, for example, the Casio PF-8000, shown in Figure 2. This was a PDA that incorporated an address book and a calculator. It was released in 1984, which is when I got mine. As can be seen in the photo, the right side of the unit consists of a touchpad.

One of the ways that you could enter numbers was to tap them out on a virtual keyboard - defined by the white grid on the touchpad. More interesting, however, was the ability to enter alphanumeric information by tracing it out on the touchpad with your finger. You wrote each character on top of the previous one (segmentation was determined by the time interval between characters), so the whole touchpad surface was used for each character.

Lest one discount the relevance of this device because it used a touchpad, rather than touchscreen, in the same year, Casio released a calculator watch, the AT-550. The watch's crystal was a touch screen. Numbers and operators are "written" on the crystal, in the same manner as the PF-8000.

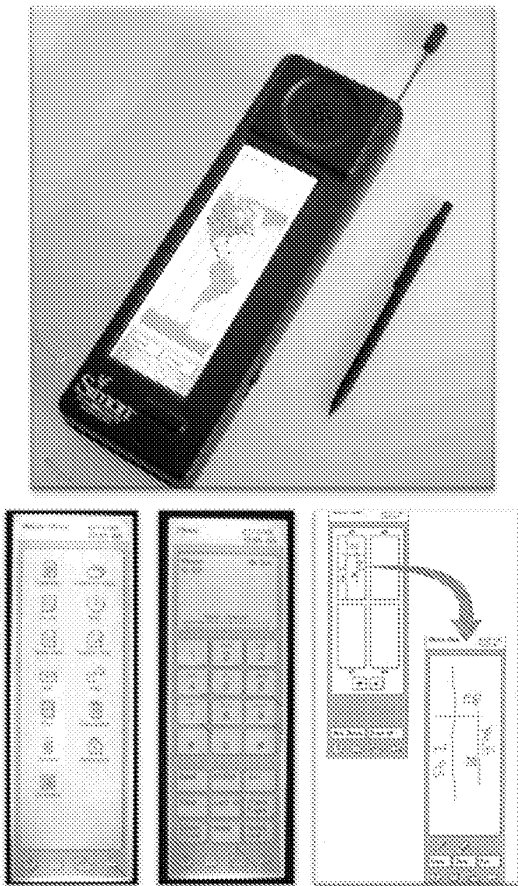

Figure 3: The Simon (1993). The phone's screen shows the display for setting the clock to world time. Interaction was via the touch screen, using either finger or stylus. L-R, the lower 3 images show (a) the desktop icons for accessing applications; (b) the phone dial pad; (c) the manual section for handling sketches and faxes. To place in context, there was no web browser: the World Wide Web had not yet happened yet!

Now flash forward and consider these devices in light of today's

world of texting and TWITTER. A few minutes of experience with the PF-8000 or the AT-550 make it clear that one can easily enter alphanumeric text without looking at the device. That is, the character recognition offers essentially the same eyes-free attribute that one has with touch typing on a QWERTY keyboard - something that I call "touch writing". Despite its relevance, this is something that is pretty much unavailable on any of today's mobile touch-entry devices. It is somewhat sobering to realize that Casio was able to do this in products commercially available 25 years ago - the same year that the very first Apple Macintosh computer was released!

Another important example is what I believe to be the world's first smartphone: the Simon [7], shown in Figure 3. This was developed jointly by IBM and Bell South, and first shown in 1993. How much this first smartphone anticipated the phones of today is only matched by how little it is known.

The Simon had only two physical controls: the on/off switch and the volume control. Everything else was controlled by the full-screen touch display - which like the Palm Pilot (which appeared in 1996) - supported both finger and stylus control.

In addition to products, early innovative work was being undertaken in various research labs. Some of the most creative work is, likewise, little known. It was done by Chris Herot and Guy Weinzapfel at the Architecture Machine Group at MIT - the predecessor to MIT's Media Lab [8].

Their work is one of the first attempts to extend the range of touch sensing beyond just horizontal and vertical position. By mounting the touch-screen overlay on strain gauges, they were also able to sense vector information in six different dimensions, as illustrated in Figure 4: force in x, y, and z, as well as torque about the x, y, and z axes.

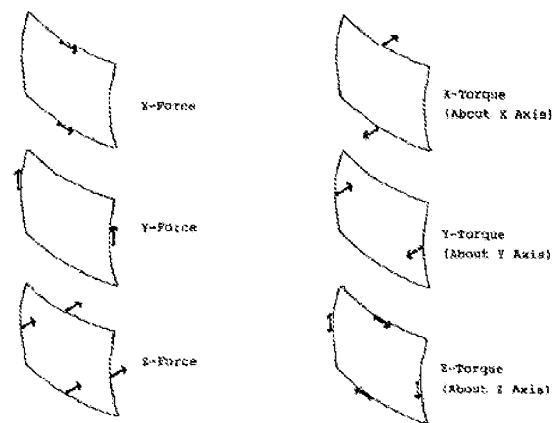

Figure 4: Multidimensional Touchscreen (1978): In addition to sensing position, this touchscreen [8] was capable of sensing 6 degrees of force vector information, including x, y, z, x-torque, y-torque, and z-torque.

Of these additional dimensions, sensing force in z (pressure) is the only one that has gained any prominence, and even that is rare. But that speaks to the nature of the beast: the challenge is, the harder one pushes, the more friction there is in sliding the finger along the surface. Hence, there is an inherent conflict between force vs. gesture articulation with touch interfaces.

This is one area where sensing technology can make a difference. Capacitive sensing has a useful attribute in this regard, as was demonstrated by Buxton, Hill and Rowley [9], among others. It goes like this: if you push hard against a surface with your finger, the force tends to cause the fingertip to spread across the surface. Hence, there is a strong correlation between pressure and surface area. Furthermore, while capacitive technologies cannot sense pressure, *per se*, capacitance does vary with the area of contact. Hence, the technology can sense an approximation of pressure – what I call “degree of touch”. Knowing this means that the user can control the degree of touch by pressing lightly and varying the contact area. Thus, the user can assert degree of touch while avoiding the friction normally associated with pressure. Yet, just like pressure, this attribute is seldom exploited by interaction designers.

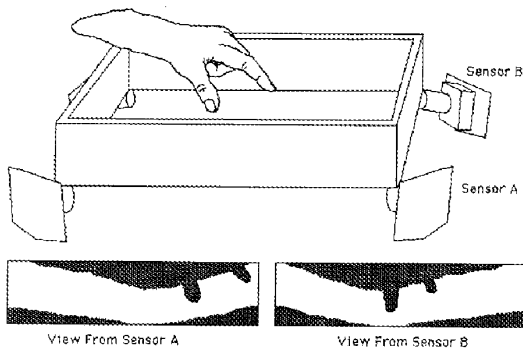

Figure 5: Sensor Frame: A prototype optical touch sensor that detects not only location, but also angle of approach[11].

In terms of exploring less commonly considered dimensions of touch sensing, I want to mention a novel approach to optical sensing of touch begun at Carnegie Mellon University by McAvinney [10], and developed further by Sensor Frame [11]. What they developed by 1988 was a device that used imaging across the display surface to sense touch location. However, unlike the light interruption techniques used with PLATO IV, this system – the Sensor Cube – used what were essentially cameras to detect the finger(s) in the volume above the display, rather than just at the display surface. Hence, as is illustrated in Figure 5, the angle of approach as well of the location of the finger could be determined.

3. Multi-Touch

The Sensor Cube had one other attribute that is sufficiently important to be worth a section on its own: the ability to sense simultaneously the location of multiple points of contact – multi-touch. This also has a history.

In 1984 our group at the University of Toronto developed a capacitive multi-touch tablet capable of sensing degree of touch independently for multiple points of contact [12]. Our initial goal in this work was to make a digital hand drum – a musical percussion instrument. Since this was, I believe, the first multi-touch device reported in the peer-reviewed literature, it is often given credit for being the first multi-touch device. Such is not the case.

The roots of multi-touch lie partially in attempts to construct tactile sensors in robotics. Examples include Wolfeld [13] and Boie [14]. However, to the best of my research, the first use of multi-touch technology for manual control of a digital system was performed by Nimish Metha as part of his MSc thesis at the

University of Toronto [15]. This system has additional interest since it is the first use that I have found of capturing touch by using a video camera to optically capture shadows from the underside of a translucent surface – anticipating many current multi-touch systems, including Microsoft Surface. Just to emphasize this point, Metha’s system was not only used to capture the shadows of fingers, but to capture and recognize shapes of objects as well!

However, to the best of my research, the first multi-touch display – the first sensor capable of simultaneously capturing multiple touch-points on a display – grew out of the aforementioned work on tactile sensors for robotics by Bob Boie.

After presenting our multi-touch tablet at SIGCHI in 1985, I was approached by Lloyd Nakatani of Bell Labs, Murray Hill, N.J. He invited me to visit the lab to see what they were doing. What I saw when I did so was a capacitive multi-touch screen that Boie had developed. Besides being transparent (ours was an opaque tablet), the performance of this device – in terms of response time – was far beyond what we had accomplished. Seeing the superiority of their system prompted me to stop working on the hardware part of the problem, and focus on the software. My assumption, hope, and expectation was that we would soon be able to get access to the Bell Labs technology. This turned out not to be the case, which was too bad, and the Bell Labs contribution went largely unknown in the larger community – although it was openly shown to me, as well as others [16].

4. A Sponge Without Water ...

Thus far, the common factor in virtually all of the work discussed is a desire to extend the range of human capability that can be captured by touch technologies. The reality is that the simple poke-to-select techniques and soft keypads seen in early systems – while useful – only scratched the surface of both the possible and the desirable.

One of the pioneers at really pushing the boundaries of capturing human gesture, and thereby laying the foundation for a great deal of current work, is Myron Krueger [17][18].

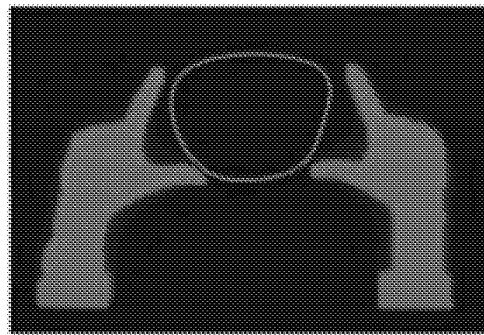

Figure 6: Myron Krueger’s Pioneering VIDEODESK, early work using rich gestures. A two-handed pinch gesture is used to govern the shape of the closed object.

Myron’s work was all about capturing human gesture, and demonstrating how it can be effectively used. He used a video camera to sense the current pose/action of the user, and then employed digital processing to isolate the human silhouette from the background. The silhouette was then analyzed and gestures extracted. These were then interpreted appropriately to bring

about the intended response in the system. One such silhouette is illustrated in Figure 6. Here, two hands are used to control the shape of a closed object. The tips of all four extended fingers affect the shape – two from each hand in this case.

What is important to recognize in approaching Krueger's work is that the technology he used was secondary. It was a means to an end, not the end itself. The underlying point was all about the gesture, not the specifics of how it was captured. Hence, while his work did not sense touch, *per se*, it is relevant nevertheless.

The primary thing that does differentiate Krueger's work from touch systems is that contact with the physical device was not sensed. Hence, proximity, gesture, and/or dwell time – rather than physical contact – was required to initiate or terminate events. However major or minor one views the consequences of such differences, the fact remains that anyone practiced in the art of touch systems, and familiar with Krueger's work, was able to immediately adapt his work to this technology – and he explicitly wrote about its applicability to touch systems [18].

There is yet another class of gesture that has early roots, and which is also having significant impact on touch-based systems. It is that class of gestures where the resulting action is a function of both where one touches, and what direction(s) one strokes/moves, once having made contact. A common example of this found in many of today's mobile phones is the ability to move forward or backward from one image to another by touching the image and quickly sliding the finger left or right on the screen.

An early (1999) example of this technique was in a product called PortfolioWall [19], shown in Figure 7. What is important is that this gesture is a specific instance of a broader class of interaction techniques known generically as *radial menus*. Simply stated, radial menus characterize a class of interaction where the response to an action is a function of both where you touched, and the direction that you move in the gesture after that touch. The options used in viewing images using the PortfolioWall are shown in Figure 8.

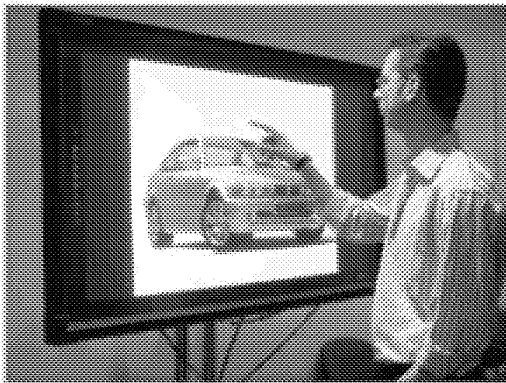

Figure 7: The PortfolioWall (1999). A sliding gesture to the left or right on top of the image moved to the next or previous image, respectively.

In addition to the left and right strokes, the radial menu shown supported the following gestures. A stroke up to the right enabled annotation, while a stroke down to the right enabled one to scale or crop the image. A stroke down closed the image and brought one back to the thumbnail view, while down to the left toggled between *Play* and *Pause* as a slideshow viewer. The menu was only displayed if one touched and held, without

moving. Since the actions were easily learned, they were normally articulated without any graphical feedback – thereby illustrating the tight relationship between radial menus and their (in this case), associated eyes-free gestures.

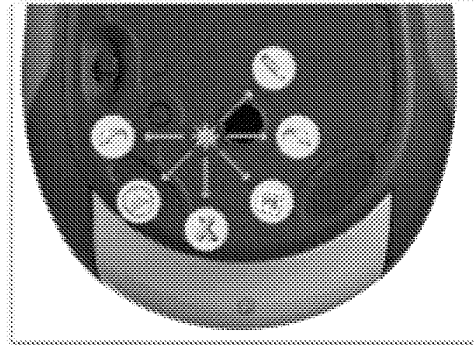

Figure 8: Radial Menu in PortfolioWall. The options when viewing a full sized image are shown by the menu.

Radial menus have a long history, beginning with the PIXIE system of Wiseman, Lenke and Hiles [20]. After a period of neglect, they were brought back into practice by Callahan, Hopkins, Weiser and Shneiderman [21], Hopkins [22], and Kurtenbach [23], for example. The key attribute that distinguishes them from conventional linear menus is that selection of action is determined by direction not distance. As human beings, we are not “wired” to make fine judgments of linear distance without looking. Yet, we *are* wired to be able to easily articulate gestures, eyes free, in any one of the eight primary and secondary directions of the compass. Therein lays the key to understanding that one should not think about radial menus as “just” menus. They also define a class of direction-based gestural interaction. And to emphasize this point, the work of Hopkins and Kurtenbach, cited above, and the PortfolioWall, makes clear that they work even if there is no menu displayed during their use.

The use of stroke direction to control the direction and type of scrolling on some current mobile devices (such as scrolling vertically, horizontally, or bi-dimensional dragging, depending on the direction of the stroke), is a good example of this, and demonstrates the relevance of radial menus to systems today.

5. Moving Forward: Touch is a Means, Not an End

Touch technologies are going to continue to evolve in terms of what they can sense and how they are used. Among other things, we are going to see ever more integration of the sensing technology with the display [24]. But while the technologies will continue to evolve, what must not get lost along the way is that it is just that, a technology, a means to an end. As I have discussed elsewhere [25], the conceptual model of the user interface is more important than the technology, and by that measure, two interfaces using different technologies (only one of which is touch) may have more in common than two where both *do* use touch.

Furthermore, while touch sensing can bring great value to an interface, even greater value can often be gained when it is used in combination, even simultaneously, with other technologies such as a stylus [26]. Again: everything is best for something and worst for something else.

6. Conclusions

From beginnings such as these have emerged the touch technologies which are having such strong impact today – these and a lot of outstanding work from a number of other researchers, designers and engineers whose work I had to neglect in this brief summary. Within this history lie important lessons and contributions that have the potential to inform our current decisions and thinking about these technologies, and their effective use going forward.

Finally, there is something in this history that can help shed light in our understanding of the nature of innovation. The length of time that it has taken for these technologies to reach “prime time” is the norm, not the exception. Innovation in our industry is almost always characterized by such a “long nose” – with 20+ years being the norm [1][2]. Hence, this paper serves a second function as a reminder that the foundation of the next ten years of innovation were almost certainly planted over the past ten years, and are just waiting there to be cultivated.

7. References

- [1] Computer Science and Telecommunications Board of the National Research Council, *Innovation in Information Technology*. (The National Academies Press, Washington DC, 2003).
- [2] B. Buxton, “[The Long Nose of Innovation.](http://www.businessweek.com/innovate/content/jan2008/id2008012_297369.htm)” BusinessWeek.com (January 2nd, 2008). http://www.businessweek.com/innovate/content/jan2008/id2008012_297369.htm
- [3] P. Betts, C.J. Brown, J.J. Lynott, H.F. Martin, “Light Beam Matrix Input Terminal,” IBM Technical Disclosure Journal, 9(5), 493-494, (1965).
- [4] A.M. Hlady, “A Touch Sensitive X-Y Position Encoder for Computer Input,” Proceedings of the AFIPS Fall Joint Computer Conference, Vol. 35, 545, (1969).
- [5] F.A. Ebeling, R.S., Goldhor, R.L. Johnson, “A Scanned Infrared Light Beam Touch Entry System,” Proceedings of Society of Information Displays,” 134-135, (1972).
- [6] L.H. Nakatani, J.A. Rohrlach, “Soft Machines: A Philosophy of User-Computer Interface Design,” Proceedings of the ACM Conference on Human Factors in Computing Systems (CHI’83), 12-15, (1983).
- [7] J.R. Lewis, “Reaping the benefits of modern usability evaluation: The Simon story,” Advances in Applied Ergonomics: Proceedings of the 1st International Conference on Applied Ergonomics -- ICAE ’96, 752-757, (1996).
- [8] C. Herot, G. Weinzapfel, “One-Point Touch Input of Vector Information from Computer Displays,” Computer Graphics, 12(3), 210-216, (1978).
- [9] W. Buxton, R. Hill, P. Rowley, “Issues and Techniques in Touch-Sensitive Tablet Input,” Computer Graphics, 19(3), 215-224, (1985).
- [10] P. McAvinney, “The Sensor Frame - A Gesture-Based Device for the Manipulation of Graphic Objects,” Carnegie-Mellon University, (1986).
- [11] Sensor Frame, “The Sensor Frame Graphic Manipulator Final Report,” NASA-CR-194243, (1992). http://ntrs.nasa.gov/archive/nasa/casi.ntrs.nasa.gov/19940003261_1994003261.pdf.
- [12] S.K. Lee, W. Buxton, K.C. Smith, “[A multi-touch three-dimensional touch-sensitive tablet.](#)” Proceedings of the ACM Conference on Human Factors in Computing Systems (CHI’85), 21-27, (1985).
- [13] J.A. Wolfeld, “Real Time Control of a Robot Tactile Sensor,” MSc Thesis. Philadelphia: Moore School of Electrical Engineering, (1981).
- [14] R.A. Boie, “Capacitive Impedance Readout Tactile Image Sensor,” Proceedings of the IEEE International Conference on Robotics, 370-378, (1984).
- [15] N. Metha, “A Flexible Machine Interface,” MSc. Thesis, Department of Electrical Engineering, University of Toronto, (1982).
- [16] D.H. Rubine, “The Automatic Recognition of Gestures,” MSc Thesis, Carnegie Mellon University, (1991).
- [17] M.W. Krueger, *Artificial Reality*, (Addison-Wesley, Reading, MA, 1983).
- [18] M.W. Krueger, T. Gionfriddo, K. Hinrichsen, “VIDEOPLACE - An Artificial Reality,” Proceedings of the ACM Conference on Human Factors in Computing Systems (CHI’85), 35 – 40, (1985).
- [19] W. Buxton, G. Fitzmaurice, R. Balakrishnan, G. Kurtenbach, “Large Displays in Automotive Design,” IEEE Computer Graphics and Applications, 20(4), 68-75, (2000).
- [20] N.E. Wiseman, H.U. Lemke, J.O. Hiles, “PIXIE: A New Approach to Graphical Man-Machine Communication,” Proceedings of 1969 CAD Conference Southampton, IEEE Conference Publication 51, 463 – 471, (1969).
- [21] J. Callaban, D. Hopkins, M. Weiser, B. Shneiderman, “An empirical comparison of pie vs. linear menus,” Proceedings of the ACM Conference on Human Factors in Computing Systems (CHI’88), 95-100, (1988).
- [22] D. Hopkins, “The Design and Implementation of Pie Menus,” Dr. Dobb’s Journal, 16-26, (December 1991).
- [23] G. Kurtenbach, “[The Design and Evaluation of Marking Menus.](#)” Ph.D. Thesis, Department of Computer Science, University of Toronto, (1993).
- [24] S. Izadi, S. Hodges, A. Butler, D. West, A. Rrustemi, W. Buxton, “[ThinSight: A Thin Form-Factor Interactive Surface Technology.](#)” Communications of the ACM, 52(12), 90-98, (2009).
- [25] B. Buxton, “[The Mad Dash Towards Touch Technology.](http://www.businessweek.com/innovate/content/oct2009/id20091021_629186.htm?chan=innovation_innovation+%2B+design_top+stories)” BusinessWeek.com, October 21, 2009. http://www.businessweek.com/innovate/content/oct2009/id20091021_629186.htm?chan=innovation_innovation+%2B+design_top+stories
- [26] K. Hinckley, M. Pahud, B. Buxton, “[Direct Display Interaction via Simultaneous Pen + Multi-touch Input.](#)” Society for Information Display (SID) Symposium Digest of Technical Papers, May 2010, Volume 41(1), Session 38, 537-540, (2010).

38.2: Direct Display Interaction via Simultaneous Pen + Multi-touch Input

Ken Hinckley, Michel Pahud, and Bill Buxton
Microsoft Research, Redmond, WA 98052

Abstract

Current developments hint at a rapidly approaching future where simultaneous pen + multi-touch input becomes the gold standard for direct interaction on displays. We are motivated by a desire to extend pen and multi-touch input modalities, including their use in concert, to enable users to take better advantage of each.

1. Introduction

We are witnessing a shift towards displays that unify *input* and *output* on surfaces that sense as well as emit. In such systems the user interacts through *direct manual input*, that is, directly on the display with his hands. By contrast, traditional graphical interfaces employ *indirect manual input* [5] using a relative pointing device (mouse) and a cursor. This shift has led to renewed interest in both touch and pen input. When integrated with a display, both pen and touch are *direct input modalities*, albeit through a physical intermediary in the case of the pen. In what shall become a theme here, this is both a strength and a weakness for the pen— as is the lack of an intermediary for touch. Having two opposing sides makes a coin no less valuable.

Despite rapture with the iPhone (and now iPad), multi-touch is not the whole story. Every modality, including touch, is best for something and worst for something else. The tasks demanded of knowledge workers are rich and highly varied [1,13]. As such one device cannot suit all tasks equally well. Your finger is no more suited for signing a contract, or drawing a sketch on a napkin, than is a pen for turning the page in a book, or holding your place in a manuscript. With the impetus to do *everything* with touch, we must underscore this point. The pen has a role to play as well.

But why the pen? Can't one type faster than one can handwrite? Yes, but only if our metric for creative output is in the cold calculus of words-per-minute. What is it that you wish to write? Are you making high-level comments on a manuscript? If so, composing your thoughts is likely to devolve into minutiae with a keyboard, whereas with a pen, brief annotations in context implicitly emphasize the important points. Likewise, if a pen is a poor choice to compose a business memo, then a keyboard is an equally poor choice to generate a breadth of design sketches [4,16]. That one form of work output is often valued more than the other in professional life is a deeper reflection on our society than it is on the effectiveness of the pen as an input device.

The transition to direct input is manifest in form factors ranging from hand-helds, slates, desktops, table-tops, and wall-mounted devices. The iPhone, Tablet PC, Wacom Cintiq, Microsoft Surface, and Smartboard are, respectively, examples of each. These examples include both pen and touch devices, but seldom does the same system support both. Even more seldom can one use both together [2,18,19], as with a stylus in the preferred hand and touch with the nonpreferred hand (*Fig. 1*). Here, we pursue pen and touch as complementary rather than competitive inputs.

Our research is based on the premise that pen+touch systems present new challenges and opportunities for the designer. Our hypothesis is that the combination of pen and touch yields a richer design space of natural gestures than multi-touch input alone. When a system does not have to provide coverage of all possible

functions with a single input modality, implicitly this leads one to ask where each modality should be used to best advantage, where a particular modality should not be used, and in what cases modalities should perhaps be treated interchangeably. To explore these issues, we prototyped a digital drafting table on the Microsoft Surface, using multi-touch and an IR-emitting pen. We developed an application for note-taking and mark-up that supports the key functions of writing, annotation, selection, copying, arrangement, and aggregation of objects [9,12,18].

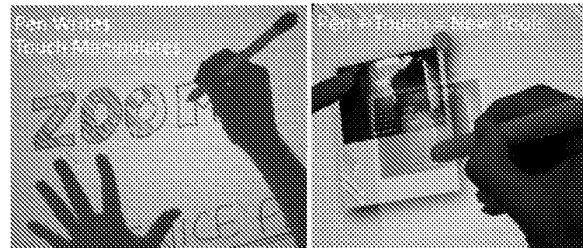

Figure 1. The roles of pen, touch, and multimodal pen+touch.

An earlier generation of devices, such as the Palm Pilot (1996), supported both pen and touch. Users could punch the on-screen calculator with their fingers, or enter Graffiti script with the stylus. Clear lessons were that the best input modality depended on the task, and that this made a significant difference to the user. However, these devices were not pen AND touch, but rather pen exclusive-or (XOR) touch. They sensed only a single point of contact, and could not distinguish touch from pen inputs. Hence we lost an opportunity for meaningful exploration of multimodal interface approaches that combine pen and touch. But a new generation of digitizers is now emerging [7] that can sense multi-touch inputs while simultaneously distinguishing pen from touch.

Why is any of this important and not just a technological quibble? The answer lies not in technology, but in the human mechanism itself, how we are wired, and how our motor, sensory, and cognitive skills have evolved. These are the underpinnings of a natural user experience, not any particular technology or device.

We have multiple fingers for a reason. We do not just point, but we also grasp and manipulate. Furthermore, our nonpreferred hand is not a poor approximation of our preferred hand; rather, it is as skilled at the specialized role that it performs as the preferred hand is at its own role [8]. For a wide class of everyday actions, our hands have evolved to complement one another. People are also predisposed to manipulate physical objects and employ manual tools. Once again, handedness plays an important role. As a simple example, when writing, we hold the pencil in our preferred hand and manipulate the paper with our nonpreferred hand. If we translate this example to a computer screen, we might write on a tablet, electronic whiteboard, or desk with a stylus, and directly manipulate the underlying virtual document, map, or photo with our nonpreferred hand using touch input.

The leap of faith we ask, and believe is justified, is to assume that the richness of such examples that exist in the physical world is matched by analogous transactions in the digital domain. By building on human behaviors and perceptual mechanisms, a

Society for Information Display (SID) Symposium Digest of Technical Papers, May 2010, Volume 41(1), Session 38, 537-540.

Contact: kenh@microsoft.com

Video & other info: <http://msrweb/adapt/asif/projects/pentouch/>

foundation of physically-grounded interactions enables natural, engaging, and novel non-physical interactions to be designed. It is the implications of this leap that motivate our research, and the purpose of this paper is to share the insights that we have gained.

2. Asymmetric Division of Labor

Let's proceed by pushing a bit harder on our pencil and paper example, by asking you to consider the following question: *Which hand do you write with, your right or your left?* Now, whether you answer "right" or "left," you are wrong. The answer is "Yes!" This is not a trick question. Rather the question is ill-posed. People write with both hands, as demonstrated by Guiard:

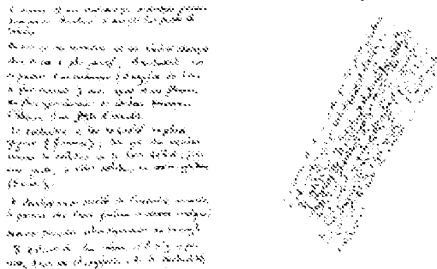

Figure 2. Guiard – transfer paper experiment [8]

What the above figure shows is the result of taking dictation on a sheet of paper. But on the right, we see the impressions left by the pen on a sheet of transfer paper surreptitiously left underneath. That is, it records the movements of the pen relative to the desk. This reveals that the nonpreferred hand sets the *frame of reference* for the action of the preferred hand; the nonpreferred hand repeatedly repositions and reorients the page so as to optimize the working space of the preferred hand [8]. This further implies that the *nonpreferred hand precedes the preferred hand* in its action.

Guiard's key insight was to turn the classic question asked in the study of handedness upside-down. Rather than asking which hand was best for a task—right or left—Guiard observed that most, if not all, manual interactions fundamentally involve both hands, with a differentiation of the roles between the hands. The correct question to ask then becomes: "What is the logic of the division of labor between the preferred and nonpreferred hands?"

Likewise, if in interface design we find ourselves asking which is best—touch or pen—then once again we must recognize an ill-posed question. The question is not which is best, but rather, *What should be the division of labor between pen and touch in interface design?* To begin to answer this question, we must consider the design properties of pen and touch as input modalities.

3. Properties Shared by Pen and Touch

We stated above that every input modality is best for something and worst for something else. Ultimately it is the designer's job to know what to use when, for whom, for what, and why. From a technology standpoint much of this turns on a nuanced understanding of the properties of an input modality. To offer insight into the main issues, the following tableau summarizes interaction properties shared by pen and touch. We do not characterize these properties as "pros" and "cons," as has been attempted elsewhere [2], to accentuate our belief that almost any property of a device can be advantageous in interaction design.

This limited survey shows that pen and touch, while sharing common ground as direct input modalities, also exhibit many important differences, and these again differ substantially from

the properties of indirect pointing devices such as the mouse. Indeed, this calls into serious question the commonplace strategy of operating systems to treat all pointing devices as "mice"—that is, interchangeable "virtual devices" [5]. Consider yourself, armed with this tableau, as licensed to fire on the spot anyone in your organization who refers to pen and touch inputs as "the mouse"—or at least to deliver a well-deserved tongue-lashing.

PROPERTY	PEN	TOUCH
Contacts	1 point <i>A single well-defined point.</i>	1-10+ contact regions <i>with shape information [6].</i>
Occlusion	Small (pen tip) <i>But hand still occludes screen.</i>	Moderate ("fat finger" [17]) - Large (pinch, palm, whole hand)
Precision	High <i>Tripod grip / lever arm affords precision, writing, sketching.</i>	Moderate <i>Nominal target width for rapid pointing is ~ 15 mm [17].</i>
Hand	Preferred hand	Either hand / Both hands
Elementary Inputs	Tap, Drag, Draw Path	Tap, Hold, Drag Finger, Pinch
Intermediary	Mechanical Intermediary <i>Takes time to unsheathe the pen. Pen can be forgotten.</i>	None: Bare-Handed Input <i>Nothing to unsheathe, nothing to lose. No lever arm.</i>
Acquisition Time	High (first use: unsheathe the pen) Moderate on subsequent uses: pen tucked between fingers.	Low <i>No mechanical intermediary to acquire.</i>
Buttons	Barrel Button (some pens)	None
Activation Force	Non-Zero <i>Tip switch/ minimum pressure.</i>	Zero (capacitive touch) <i>Resistive touch requires force.</i>
False Positive Inputs	Palm Rejection (while writing) <i>Palm triggers accidental inputs, fingers drag on screen, etc.</i>	"Midas Touch Problem" <i>Fingers brush screen, finger on screen while holding device, etc.</i>

Figure 3. Tableau of design properties for pen and touch.

4. Graceful Degradation

We now consider *stationary* versus *mobile* usage contexts. Desktop, table, and wall displays are necessarily stationary, but form-factors such as slates transition between mobile and stationary use. To design a consistent user experience spanning all of these form factors, we seek a conceptual model that supports *graceful degradation* between stationary and mobile usage. For the latter the nonpreferred hand is largely occupied by holding the device itself, whereas for the former we wish to support efficient bimanual interactions that leverage the full potential of human hands, as well as simultaneous pen + touch input.

For example, with physical notebooks we have observed that people deftly *tuck the pen between the fingers of the preferred hand* while flipping pages or grasping scraps of paper [11]. Hence, users can effectively perform multi-touch gestures, such as pinching, while holding the pen tucked between the fingers, and thereby derive significant value even from unimanual interactions that interleave pen and touch inputs as needed. It is important to observe here that a mobile usage model, which *assigns core operations to unimanual touch with the preferred hand*, also serves a stationary usage model that instead assigns these tasks to *touch with the nonpreferred hand*. Bimanual pen + touch gestures can then be articulated in cooperation with the preferred hand to support more efficient interaction as well as advanced gestures.

5. Recognition and Modes

The next distinction we draw is that of *ink* vs. *command* input. The specter of recognition arises as soon as one contemplates marking a virtual sheet of paper. Does drawing a mark leave an

ink stroke, is it immediately converted to text, or is it perhaps recognized as a command, such as a gesture to make copies, move objects, or turn the page? Ascribing intent to the motions of an input device is a fundamental problem. People often seem to assume that recognition can overcome this problem. In our view, it does not and will not. But let's back up a moment. Who is it that must do the recognition, and why? Rarely does a user say "I wish this sheet of paper could understand what is written on it." Notes in a notebook are for oneself. Annotations on a document are offered as feedback to another person. Significant value arises from experiences where it is a human who recognizes the marks.

Let's say that we do wish to recognize some strokes as gestures. Implicit in this statement is the need to distinguish a *command mode* for gestures as distinct from *ink mode* for leaving marks on the digital paper. Holding a button on the pen, or tapping on a lasso-selection icon, for example, are classic ways of *mode switching* between ink and commands in pen interfaces [15]. One often hears that "modes are bad," but modes are necessary to provide rich interfaces [10] that don't depend on the success of brittle recognition techniques. The key is to rapidly switch modes in a manner that is minimally demanding of the user's cognitive resources. Here, pen+touch has much to offer.

If we assign pen to *ink mode* and touch to *command mode*, the design then *puts the mode switch in the user's hands*. For example, in our prototype the user can jot notes with the pen, but then pinch with two fingers to zoom, swipe across the margin to flip pages, or use a single finger to drag objects such as photos. That is, when considered as unimodal inputs, the logic of the division of labor between pen and touch is that *the pen writes, and touch manipulates*. The mode switch occurs implicitly depending on whether the user interacts with pen or touch. As a desirable side-benefit, this strategy also can dispense with many ancillary interface widgets, such as toolbars stuffed with icons. This leaves more display space for the user's work, while reducing the distraction of secondary controls.

Drawing on all that has preceded, we now see how our approach falls into place along the dimensions that we have identified:

- Pen vs. touch modalities have differentiated effects in the interface. Ink mode is assigned to the pen, while multi-touch articulates commands: the pen writes, and touch manipulates.
- The user can efficiently interleave pen and touch inputs with the preferred hand for mobile, unimanual usage scenarios;
- Designing core tasks for unimanual touch serves mobility while also enabling stationary bimanual interaction that instead assigns these tasks to the nonpreferred hand;
- These benefits are derived while leaving open the possibility of bimanual manipulations with simultaneous pen and touch.

It is in the consideration of this final point, where some of the most novel possibilities may lie, that we now turn our discussion.

6. From Elementary Inputs to Phrases

The preceding interactions that interleave pen and touch may suffice to justify further investment in pen+touch displays. However, we now consider creative ways for interaction designs to leverage *simultaneous pen and multi-touch* interactions to support new capabilities for multimodal bimanual interaction. Let's consider a typical direct-manipulation pen interface for copying an object such as a photo on a digital notebook page [12]. To copy the photo and place it at a desired position, the user must:

1. *Switch the pen from ink mode to command mode;*

2. *Select a photo by tapping or lassoing it with the pen;*
3. *Invoke Copy by selecting a command from a context menu associated with the selected photo;*
4. *Invoke the Paste command to place the copy onto the page;*
5. *Drag the copy to the desired location on the page;*
6. *Return the pen to ink mode.*

Now, let's contrast this with how our system implements a simultaneous pen+touch gesture for copying a photo. All the steps required by the canonical direct-manipulation approach can be phased into a single pen+touch bimanual gesture as follows:

1. *Hold photo and drag off a copy with the pen (Fig. 1, right).*

Is this really just one step? Our observations of users suggest that this dedicated pen+touch gesture corresponds closely to the user's mental model of the common use case where one wants to create and place a copy of an object [14]. Hence, the gesture feels like a unitary action to the user, despite invocation of multiple input events on the devices. Consistent with Guiard [8], holding touch precedes the action of the pen, and frames the context of subsequent actions of the pen held in the preferred hand.

Not only does this approach have fewer steps, but by its very nature it encapsulates all the steps into a single gestural phrase. It is syntactically simpler and precludes many types of errors, including mode errors, that can occur with a traditional approach.

Where does the syntactical simplification come from? First, note that holding a finger on the photo *integrates object selection with the transition to gesture mode*. This combines two steps. Once the photo is held with a finger, dragging off a copy with the pen embeds three different pieces of information: the Copy command (verb), what is to be copied (direct object), and where it is to be copied to (indirect object) [14]. Finally, closure is inherent in the means used to introduce the phrase: simply releasing the nonpreferred hand from the screen returns the system to its default state (ink mode), where the pen once again writes. The muscular tension from maintaining touch on the photo is the glue that holds all of these steps together. The muscular tension also has the virtue that it provides continuous proprioceptive feedback to the user that the system is in a temporary state, or mode, where the action of the pen will be interpreted differently.

We focus on the *copy* gesture above, but our system implements many pen+touch gestures. For example, users can employ the pen to *slice* photos by holding a photo with a finger, and then crossing the photo with the pen to define a freeform cut path. Or one may draw a *straightedge* by holding a photo and stroking the pen along its edge. One may even combine these actions into compound phrases, such as by holding an object and then *slicing* along the *straightedge* thus defined (Fig. 4). This illustrates the richness of the vocabulary that users may articulate with our approach.

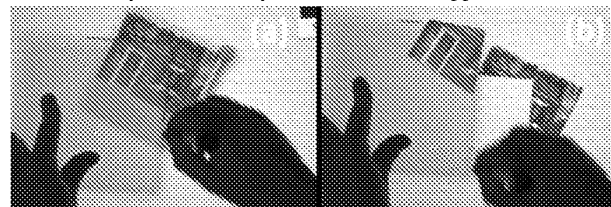

Figure 4. A pen+touch phrase: slice photo along a straightedge.

Earlier in the discussion above we stated a principle: the division of labor between pen and touch for unimodal inputs is that *the pen writes, and touch manipulates*. Now, we can articulate how our

system interprets *multimodal* pen + touch inputs: *the combination of pen + touch yields new tools*, such as the aforementioned copy, slice, and straightedge tools. If pen+touch yields new tools, implicitly this means that in some contexts we must violate the original principle: the pen does not always write, nor does touch always manipulate. Our explorations convince us that if a system strictly limits itself so that the pen ONLY writes, and touch ONLY manipulates, this leads to a simple and consistent but artificially crippled system.

By treating multimodal pen + touch inputs differently, our system opens up a design space of new gestures that also have the virtue of leveraging how people naturally use their preferred and nonpreferred hands together. We emphasize the strengths of pen and touch as input modalities, while their use in conjunction allows us to simultaneously sidestep many of their weaknesses.

7. Incidental Contact (Palm Rejection)

Despite the advantages enumerated above, simultaneous pen and touch suffers a serious limitation in that if one rests the palm of the hand on the screen while writing, this represents a “touch” to the computer. The result may be false inputs such as accidentally panning or zooming the page. Our work partially addresses this problem, but to be clear, we do not claim to have solved it.

A simple form of palm rejection goes a long way: one just discards touches with a large contact area. However, large touches start small as the hand moves into contact with the display. Furthermore, the knuckles or side of the hand may precede the pen as it comes into contact with the display. Hence, deciding whether a touch is a true intentional manipulation is not an instantaneous binary decision, but rather is a real-time assessment that varies as the articulation of a combined pen and touch movement plays out over time.

Likewise, in reference to the tableau of Fig. 3, we must recognize that since many touch technologies require zero contact force to trigger an input, false positive inputs will remain an inherent property of multi-touch interaction, including its combination with pen input. As such, clever interaction technique designs that take advantage of this fact [3], as well as more sophisticated “accidental touch” filtering algorithms, will be integral to a rewarding pen+touch user experience. These are fundamental issues that urgently need further research.

8. Conclusion

People have multiple fingers, two hands, and highly developed skills for handling physical objects: we have shown how all of these are defining characteristics of natural pen and touch interaction. Likewise we have shown how our design carefully considers mobile vs. stationary use, ink vs. command input, and the phrasing of elementary actions into higher-level constructs that suit the user’s mental model. The map of issues that we have laid out in this manuscript should help the reader to navigate through this thicket of interrelated issues and considerations.

We have advocated a division of labor between pen and touch where the pen writes, touch manipulates, and the combination of pen+touch yields new tools. This articulates how our system interprets unimodal pen, unimodal touch, and multimodal pen + touch inputs, respectively. We have contributed novel pen + touch gestures, while also raising, by way of examples, design issues and questions for the reader to ponder. How should the roles of pen and touch be differentiated (or not) in your own user interface

designs? The answers may differ for users of your system, but the design issues we have identified here will arise again and again.

Widespread enthusiasm for multi-touch interfaces belies an oft-overlooked truth: without careful design and a deep understanding of the strengths and weaknesses of touch as an interaction modality, a natural interface a touch-screen does not make. It has to be kept in mind that there is a difference between an *input technology* and either an *interaction technique* or a *conceptual model*—much less a natural *user experience*. Hence, touch and pen input technologies only lead to a natural experience when lots of hard work meets a thorough and nuanced understanding of these modalities, their strengths and weaknesses, when to use them, and when not to use them. Our goal here has been to impart a sense of these issues, as well as to provide example techniques that illuminate the design space. Our hope is that this can help to spur the further excitement and investment necessary for the emerging area of pen + touch input to flourish as the future of displays.

9. References

- [1] Adler, A., Gujar, A., Harrison, B.L., O’Hara, K., Sellen, A. *A diary study of work-related reading design implications for digital reading devices*. CHI’98.
- [2] Brandl, P., Forlines, C., Wigdor, D., Haller, M. and Shen, C. *Combining and measuring the benefits of bimanual pen and direct-touch interaction on horizontal interfaces*. AVI’08 Conf. on Advanced Visual Interfaces. p. 154-61.
- [3] Brandl, P., Leitner, J., Seifried, T., Haller, M., Doray, B., To, P. *Occlusion-aware menu design for digital tabletops*. CHI 2009 Extended Abstracts.
- [4] Buxton, B., *Sketching User Experiences: Getting the Design Right and the Right Design*. 2007, San Francisco: Morgan Kaufman.
- [5] Buxton, W., *Touch, Gesture, and Marking*, in *Readings in Human-Computer Interaction: Toward the Year 2000*, R. Baecker, et al., Editors. 1995, Morgan Kaufmann Publishers. p. 469-82.
- [6] Cao, X., Wilson, A.D., Balakrishnan, R., Hinckley, K. and Hudson, S.E. *ShapeTouch: Leveraging contact shape on interactive surfaces*. IEEE TABLETOP 2008 International Workshop on Horizontal Interactive Human Computer Systems p. 129-36.
- [7] Engelhard, L. *Native Dual Mode Digitizers: Supporting Pen, Touch and Multi-Touch Inputs in One Device on any LCD*. Society for Information Display SID 08 Digest. p. 1306-09.
- [8] Guiard, Y., *Asymmetric Division of Labor in Human Skilled Bimanual Action: The Kinematic Chain as a Model*. The Journal of Motor Behavior, 1987. 19(4): p. 486-517.
- [9] Hinckley, K., Dixon, M., Sarin, R., Guimbretiere, F. and Balakrishnan, R. *Codex: a dual screen tablet computer*. CHI 09. p. 1933-42.
- [10] Hinckley, K., Guimbretiere, F., Baudisch, P., Sarin, R., Agrawala, M., Cutrell, E. *The Springboard: Multiple Modes in One Spring-Loaded Control*. CHI 06.
- [11] Hinckley, K., Yatani, K., Pahud, M., Coddington, N., Rodenhouse, J., Wilson, A., Benko, H. and Buxton, B. *Mammal Deskterity... An Exploration of Simultaneous Pen + Touch Direct Input*. ait chi, CHI 2010 Extended Abstracts (non-archival publication). [video]
- [12] Hinckley, K., Zhao, S., Sarin, R., Baudisch, P., Cutrell, E., Shilman, M., Tan, D. *InkSeine: In Situ Search for Active Note Taking*. CHI 2007.
- [13] Kidd, A. *The marks are on the knowledge worker*. CHI 94. p. 186-91.
- [14] Kurtenbach, G. and Buxton, W. *Issues in Combining Marking and Direct Manipulation Techniques*. UIST’91. p. 137-44.
- [15] Li, Y., Hinckley, K., Guan, Z., Landay, J. *Experimental Analysis of Mode Switching Techniques in Pen-based User Interfaces*. CHI 2005. p.461-70.
- [16] Oviatt, S., Cohen, A.O., Mann, A.J., *Designing Interfaces that Stimulate Ideational Super-fluency in Science*, Communications of the ACM.
- [17] Vogel, D. and Baudisch, P. *Shift: A Technique for Operating Pen-Based Interfaces Using Touch*. CHI 2007.
- [18] Wu, M., Shen, C., Ryaal, K., Forlines, C. and Balakrishnan, R., *Gesture Registration, Relaxation, and Reuse for Multi-Point Direct-Touch Surfaces*, in *IEEE International Workshop on Horizontal Interactive Human-Computer Systems*. 2006. p. 185-92.
- [19] Yee, K.-P. *Two-Handed Interaction on a Tablet Display*. CHI 2004.

UNIVERSITY OF TORONTO
ARCHIVES

Ref: 11984-3006(24)

This copy is made for research purposes only and
not for reproduction.
All responsibility for questions of copyright that
may arise in the use of this copy is assumed by
the recipient.

A FAST MULTIPLE-TOUCH-SENSITIVE INPUT DEVICE

by

SEONKYOO LEE
1/1

A Thesis Submitted in Conformity with
the Requirements for the Degree of
Master of Applied Science
in the
Department of Electrical Engineering
University of Toronto

October 1984

© Seonkyoo Lee 1984

ABSTRACT

Touch sensitive input devices in various forms have appeared in increasing numbers in the market place. Available devices, however, are deficient in the number of parameters that can be obtained from a human gesture. Most provide only the location of a single finger tip. But there are more parameters of interest, the pressure of a single touch or the existence of multiple touches for example.

This thesis describes the design and implementation of a fast-scanning multiple-touch-sensitive input device. This device utilizes a capacitance sensing technique in conjunction with a binary scanning algorithm for both flexibility and speed.

The resolution of the sensor matrix provided is variable to allow a tradeoff between resolution and speed. Even though the apparent maximum hardware resolution is fixed to be 64 by 32, the resolution can be further increased through the application of various interpolation schemes.

ACKNOWLEDGEMENT

I would like to express my sincere gratitude to Professor K.C.Smith for the extent of his support and encouragement and to Professor William Buxton for his many useful ideas on the project.

I owe special thanks to my brother Seonjo Lee who helped me in building the touch tablet and to my wife Cheekyun Lee who has encouraged me through the last two years.

Grateful acknowledgement is given to the National Engineering and Science Research Council for scholarship support during the course of my study and for the Operating Grant support of my advisors, Professor William Buxton and K.C.Smith.

TABLE OF CONTENTS

1. INTRODUCTION

1.1 INTRODUCTION 1-1

1.2 ORGANIZATION OF THESIS 1-3

2. DESIGN PROCESS

2.1 INTRODUCTION 2-1

2.2 EXISTING TOUCH SENSITIVE INPUT DEVICES 2-2

2.3 SHORTCOMINGS OF EXISTING DEVICES 2-7

2.4 APPROACHES TO THE PROBLEMS 2-9

2.5 CONCLUSION 2-15

3. HARDWARE DESIGN AND IMPLEMENTATION

3.1 INTRODUCTION 3-1

3.2 THE SENSOR MATRIX 3-2

3.3 INTERFACE CIRCUIT DESIGN AND IMPLEMENTATION 3-10

3.4 HARDWARE SCANNING SEQUENCE 3-14

3.5 CONCLUSION 3-15

4. ALGORITHMS AND SOFTWARE STRATEGIES

4.1 INTRODUCTION 4-1

4.2 SENSOR GROUPING STRUCTURE 4-2

4.3 BIT PATTERNS IN SELECTION REGISTERS
AND ADDRESS MAPPING 4-4

4.4 NOISE REDUCTION 4-6

4.5 SCANNING ALGORITHMS 4-8

4.6 COMPENSATION FOR LOW RESOLUTION HARDWARE 4-10

4.7 SEQUENCE OF OPERATION 4-12

4.8 CONCLUSION 4-15

5 PERFORMANCE TESTING

- 5.1 INTRODUCTION 5-1
- 5.2 SENSOR MATRIX EVALUATION 5-2
- 5.3 USE OF PROTOTYPE 5-6
- 5.4 SPATIAL RESOLUTION 5-7
- 5.5 RESPONSE TIME DELAY 5-9
- 5.6 TYPICAL APPLICATIONS 5-10
- 5.7 CONCLUSION 5-12

6 CONCLUSION

- 6.1 INTRODUCTION 6-1
- 6.2 ENHANCEMENT POSSIBILITIES 6-2
- 6.3 SENSOR MATRIX ENHANCEMENT 6-4
- 6.4 FUTURE RESEARCH 6-6

REFERENCES

- Appendix A Analysis on Sensors in One Column
- Appendix B Subtraction of Overflowed 9-Bit Counter Values
- Appendix C Subroutines, Commands, and Data Formats

CHAPTER 1

INTRODUCTION

1.1 INTRODUCTION

The rapid advancement of computer technology today has opened a variety of computer applications such as music, graphics, medical diagnosis, education, and text processing. Correspondingly, input devices to computer systems have grown quite numerous. A piano keyboard transducer, for example, is one such input device for music applications. Positioning devices are seen to be essential to graphics applications; image transducers are required for pattern recognition in medical diagnosis; touch screens are appropriate for the education of young children; while the Qwerty keyboard remains the usual standard for text processing. Since no single one of these specialized input devices fully utilizes the computer in some particular application, a combination of several different devices is seen to be useful and necessary.

A particular input mechanism of interest is finger motion. Input devices utilizing finger gestures are still numerous; to name a few, there are the Qwerty keyboard, the

Piano keyboard, various positioning devices such as the joystick, the light pen, the touch screen, and the graphics tablet. However, each of these devices is more or less specialized to a particular application as indicated above.

It would be desirable to have one or two devices serve all functions. However, a danger remains that such a device would not really suit all applications; there is the possibility that while it serves all, it pleases none. [ref 1.1] The solution of this difficulty seems to lie in a combination of the adaptability and flexibility of the device. Here adaptability refers to the reconfigurability of the device to a particular application, whereas flexibility denotes the ease with which a new application may be adapted.

In an effort to find a general-purpose input device that is well suited for a wide range of tasks, many input devices and their transducers have been examined in this work. The result has been the development of a fast-scanning multiple-touch-sensitive input device. This device generates x, y and z coordinates for a particular touched position of a tablet surface utilizing a capacitance measurement technique. Unlike the previously developed capacitance touch tablet by L. Sasaki and G. Fedorkow at the University of Toronto [ref. 2], it can detect simultaneous multiple finger touches without ambiguity.

The introduction of "multiple sense" opens up many new possibilities for application of the device. For example a multiple-touch-sensitive device can simply emulate a piano keyboard using an appropriate template on its touch surface. Such emulation is not possible using only single-touch-sensing transducers. As well, the touch resolution of such a tablet may be enhanced by an interpolation of many adjacent points simultaneously touched. In this way, it is possible to increase the number of parameters available as input to the computer. For example, information on the distribution of finger points can be provided to the computer in terms of a line representation drawn through the center of the point distribution together with a measure of a spread of the distribution.

As well of course in a general sense, the availability of intensity at each x,y coordinate further enhances the capability of this device in comparison to a simple positioning device.

1.2 THESIS ORGANIZATION

As a preliminary design process, chapter 2 presents a survey of touch transducers and devices currently in use. Hardware and software requirements for the development of the fast-scanning multiple-touch-sensitive tablet are also

presented. Hardware for the sensors and the corresponding interface circuits are described in chapter 3. Software and algorithms for the fast scanning technique are presented in chapter 4. Chapter 5 integrates the hardware and software together as a system for performance testing. As well, in this chapter, the sensors are characterized in terms of their performance. Finally the last chapter suggests future research and directions for the enhancement of the device in terms of its manufacturability and performance.

CHAPTER 2

DESIGN PROCESS

2.1 INTRODUCTION

A fruitful approach to developing a flexible multi-purpose input device is seen to lie in determining the amount of information that can be simply and conveniently provided through a single device. This is contrast to seeking ways of combining a number of existing devices.

The information that the user provides could be by means of physical gesture. To the user this implies repeatability such that the same gesture results in the same meaning, and dexterity in order that a variety of parameters can be produced with minimum sequence of expressions. The human hand can provide both required characteristics.

In particular, a simple natural communication technique is "TOUCH". Touch itself in general contains much more information than simply physical location. It could convey additional information such as, for example, the pressure or speed of touch of one or more moving fingers.

This chapter outlines the preliminary design processes leading to the development of a fast multiple-touch-

sensitive input device(FMISID).

Section 2.2 presents five existing touch-sensitive devices with emphasis on their sensing mechanisms; section 2.3 discusses the shortcomings of the existing tablets; section 2.4 defines what must be done to the hardware and software to achieve FMISID; and finally, section 2.5 concludes this chapter.

2.2 EXISTING TOUCH-SENSITIVE INPUT DEVICES

This section outlines existing touch tablet or screen sensing mechanisms emphasizing those using resistive, infrared, ultrasound, capacitive, and video techniques.

Resistive:

There are several approaches to the use of resistive sensors for pointing location on a tablet. Two specific and distinctive approaches are examined, namely those of the Elographics data tablet and a high resolution imaging touch sensor developed at M.I.T.

The Elographics data tablet [ref 2.1] uses a uniform resistive substrate with resistors attached to the edges in order to compensate non uniformity of the mapping between resistance and position. When the tablet is touched, pressure from the finger tip causes a deformable coversheet with

a conductive layer to contact the resistive substrate. A low voltage is applied alternatively along orthogonal axes to the edges so that each axis is exclusively selected to measure the voltage at the touch point which is a function of the distance from the selected edge. Figure 2.0 represents the functional models and construction of the Elographic tablet.

The M.I.T high resolution imaging touch sensor [ref 2.2] consists of a flexible printed circuit board, a sheet of unidirectionally uniform conductive silicone rubber and a separator to pull the conducting layer apart when pressure is released. The sensor arrays and electrical model of one row are shown in Fig. 2.1 and 2.2. The image of the touch is derived from the measurements of the impedances of all columns and rows in the resistor matrix. The individual impedance in a column [Fig 2.2] $R[n]$, is obtained from successive measurements of the two port parameters of the sub-networks. The relevant equations are as follows:

$$Z[0] = 0$$

$$G[0] = 1$$

$$R[n] = \frac{V - I[n] * G[n-1] * (Z[n-1] + R_L)}{I[n]}$$

$$Z[n] = R[n] * \frac{Z[n-1] + R_L}{Z[n-1] + R[n] + R_L}$$

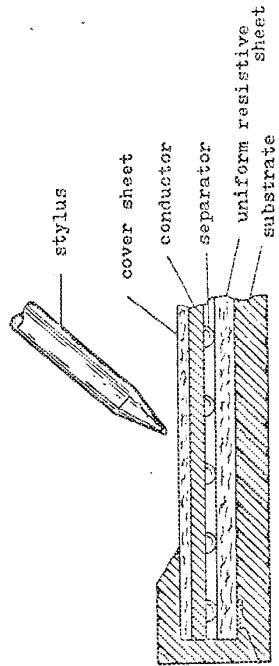
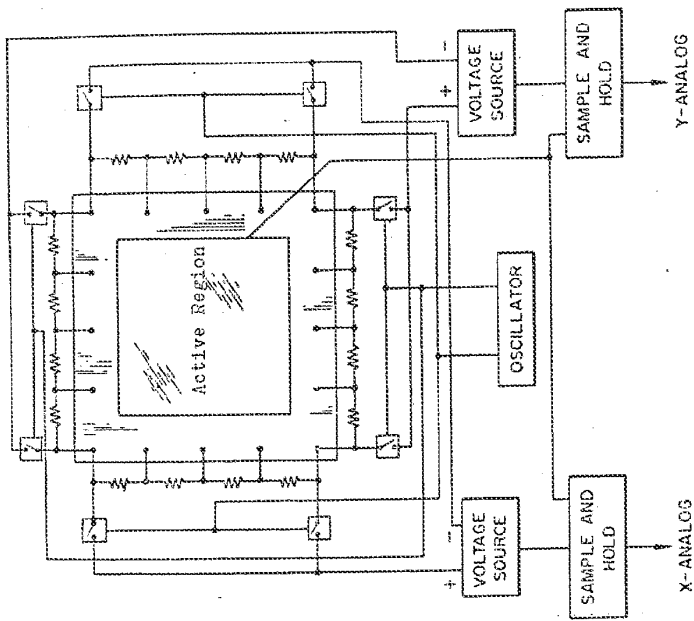

Fig. 2.0 Block Diagram and the Cross-section of the Eicographics Data Tablet

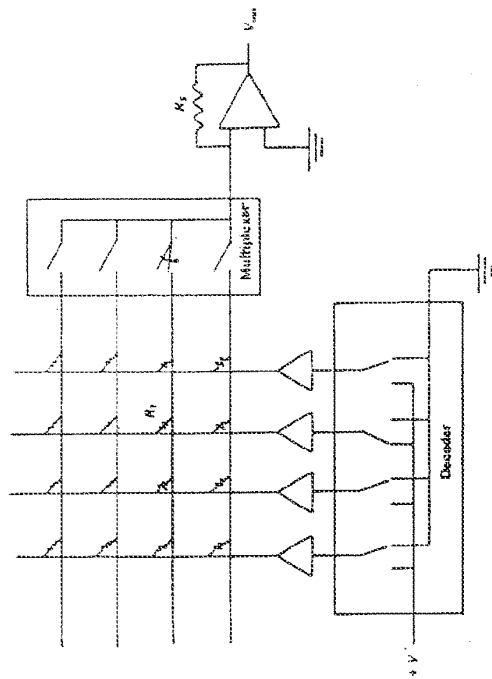

Fig. 2.1 Electrical Model of M.I.T. Imaging Touch Sensor

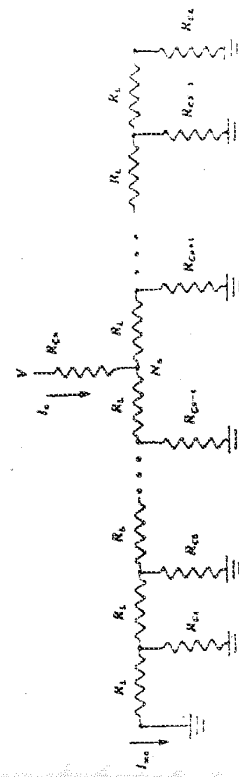

Fig. 2.2 Electrical Model of one Row of M.I.T. Imaging Touch Sensor

Here V is the applied voltage, $I[n]$ and $I[mn]$ the measured currents, $Z[n]$ the input impedance, $G[n]$ the voltage transfer ratio of the network to the left of $R[n]$, and R_i is the linear resistance of the unidirectional uniform resistive rubber sheet.

From these equations, the value of $R[n]$ is obtained only when $R[n-1]$ is known.

Infrared:

Infrared(IR) is one of the oldest techniques used in current sensing systems. A representative example in current use is that in the HP personal computer system. [ref 2.3] A number of the IR detectors and equal number of IR emitting diodes are mounted opposite to each other in horizontal and vertical directions such that the presence of a finger tip can be detected by the absence of the IR light at the horizontal and the vertical detectors.

Ultrasound:

The ultrasound sensor technique has been used in various areas. One of the applications in a touch sensitive input device employs piezo electric transducers mounted on horizontal and vertical edges of transparent glass screen. Here, the acoustic wave (Rayleigh wave) generated by the transducer travels along the free boundary of the glass, much like the ripple on a pond. A reflected wave or echo is

initiated by a touch on the surface. The time intervals between the arrival of the echo and the beginning of the transmission of the source signal, measured in two directions as shown Fig. 2.3 give the information on the position of the object. The touch sensor shown Fig. 2.3, developed by T.S.D Limited [ref 2.4], actually provides outputs of $x+y$ and $2y$ enabling the derivation of x and y where x and y are the distance horizontally from a vertical edge and vertically from a horizontal edge respectively.

Video Technique:

The video approach to the touch input device uses a T.V camera to scan a translucent plate on which the finger tip is placed. The signal from the TV camera is then processed to obtain one bit of information per pixel. Using a programmable threshold voltage, one bit per pixel is obtained to determine the shape of a 2-D projection of an object on the plate. The data resulting from this process are stored in a memory to which access by a dedicated processor is allowed. This processor implements further processes such as determining non-zero locations in the memory (that is, the position of the object) and identifying shapes (grouping the pixels for an object). Nimish Metha presented such a system [ref 2.5] whose basic configuration is shown in Fig. 2.4.

Capacitive:

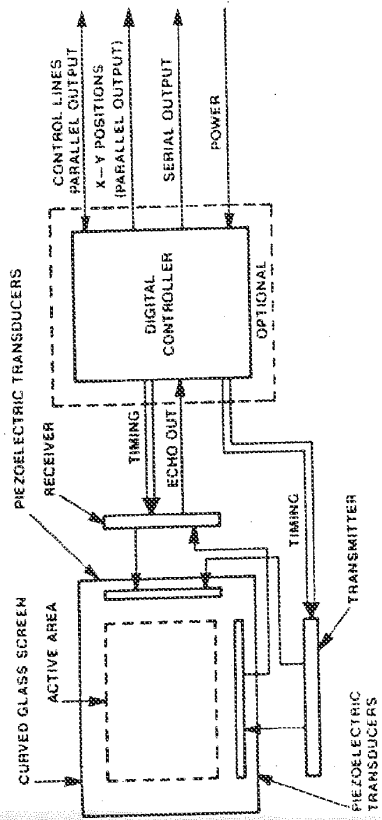

Fig. 2.3 Block Diagram of Touch Screen Digitizer

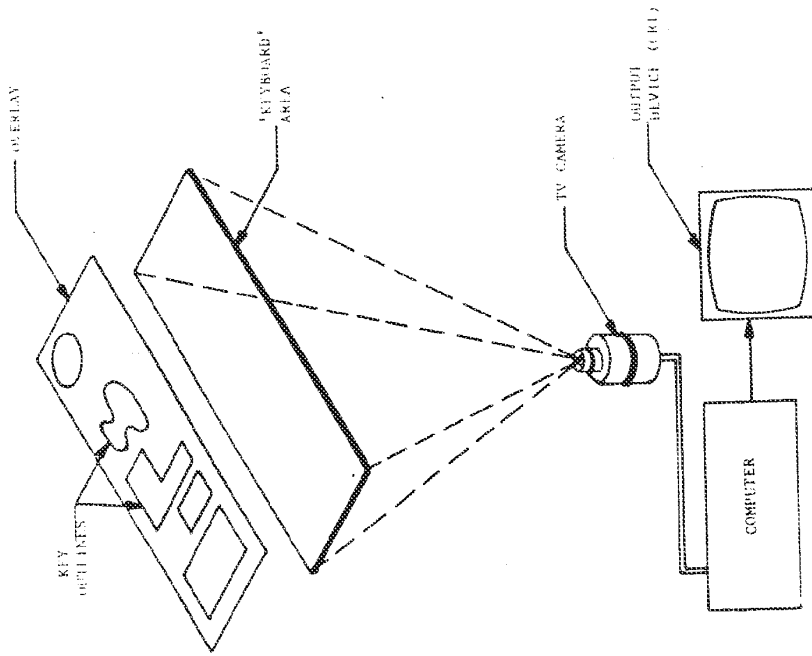

Fig. 2.4 Video System for Touch Tablet

Capacitive sensors are used in various applications such as single touch switches and touch tablets. Two kinds of touch tablet using capacitive sensors will be examined here. The one developed by TASA [ref 2.6] shown in Fig 2.5 measures the capacitance between the plate and the area covered by the touch. This measured datum is then compared with a previous reading stored in a shift register. In order to reduce the size of the shift register, a tablet is divided into many sub-regions in which the position of the touch is uniquely located. One such sub-region is much larger than the maximum size of a single touch so as to avoid an overflow. TASA utilizes the sensor to detect relative movements of a finger rather than its absolute position.

Another capacitance tablet developed by Sasaki, Fedarkow and others at the University of Toronto [ref 2.8] uses sensors for the rows and columns which are interleaved as shown in Fig 2.6. It uses analog multiplexors to select a row or a column sensor. In order to find the capacitance of a row or a column, it counts the time to charge up the capacitive sensor. Because the capacitance of the sensors on the tablet without a touch is not constant, and the capacitance change produced by a touch is relatively small compared to the capacitance of the surroundings, the system uses a measure of the initial capacitances of the sensors (without touch) whose values are stored in the memory for

reference. The touch point is determined by finding a set of the maximum difference values (current value less the reference value) for the rows and columns.

2.3 SHORTCOMINGS OF EXISTING DEVICES

The scanning properties of the devices described in the previous section can be distinguished depending on their position, pressure and multiple touch sensing capabilities. All the devices or transducers referenced are capable of locating the position of a touch, with a resolution which is characteristic of each device. Only capacitive sensors and the MIT resistive sensor provide pressure of touch whereas the video system and the MIT resistive sensor give a multiple touch capability.

Projective sensors, that is, all of the sensors introduced in the previous section except the video system and the MIT high resolution resistive sensor, cannot detect multiple touches without ambiguity since the detection of touch by two horizontal and two vertical sensors can be interpreted in seven possible ways as shown in Fig. 2.7.

In general, the missing data may be retrieved by introducing more axes, as is done in a tomographic imaging system. Using this scheme, if the upper limit of the number of touch points is two, the introduction of one more axis

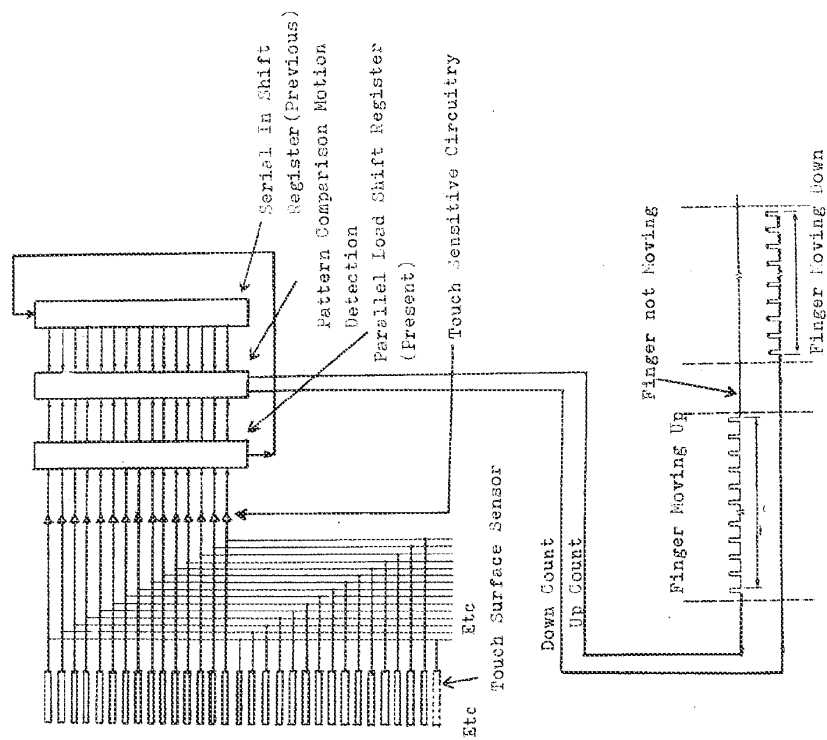

Fig. 2.5 Block and Time Diagram of TASA Touch Tablet

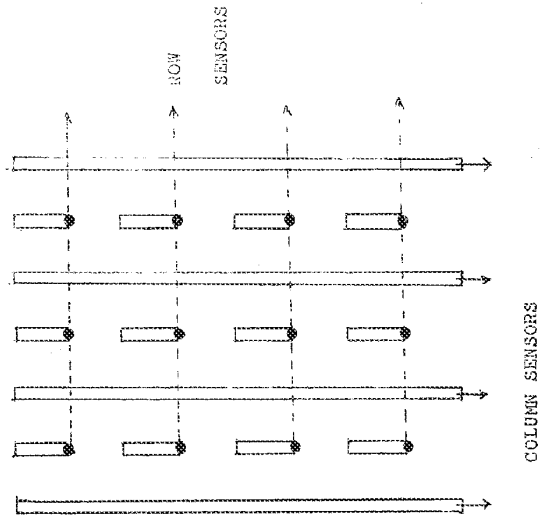

Fig. 2.6 Capacitive Sensor Configuration of the U of T Touch Tablet

clearly distinguishes at least two points as shown (a) and (b) in Fig 2.7. At least two additional axes are required to distinguish two points without ambiguity if an upper limit to the number of touches is not assumed. Cases in which the number of touches is more than two are shown in (c) to (g) in Fig. 2.7. But as soon as the number of axes is increased, the attraction of any scheme of 2-d projection diminishes because the cost of implementation rises greatly. For example the capacitive tablet may require an unimplementable number of wire layers whereas introduction of sensors and sources for IR and Ultrasound schemes may be extremely difficult. Moreover as the number of the touch points increase, additional axes do not help in resolving a basic shortcoming of the sensor from which only on and off information is available. This is the existence of a region for which identification of points inside is not possible as shown Fig. 2.8.

The video technique seems to solve all the problems embedded in all of the "projective sensor" systems including pressure if "area of touch" by a compressible finger corresponds to the pressure. But a video system is quite bulky due to the optical enclosure and it is slow because it has to access the data stored in memory by the camera processing unit. The maximum speed is limited by the scan rate of the camera (30 per second) even though this maximum can be achieved only by pipelining all the processes required.

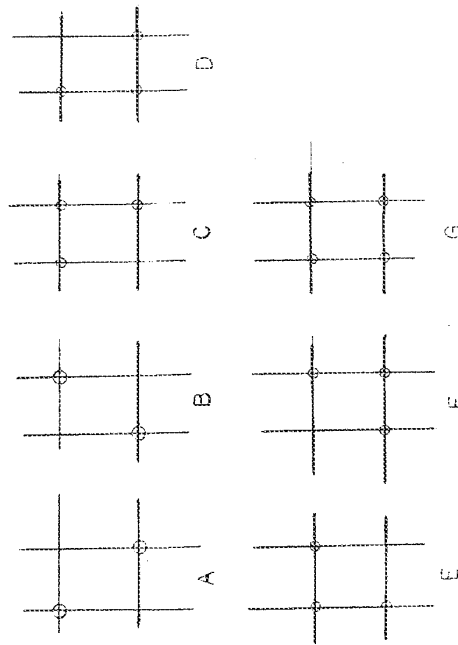
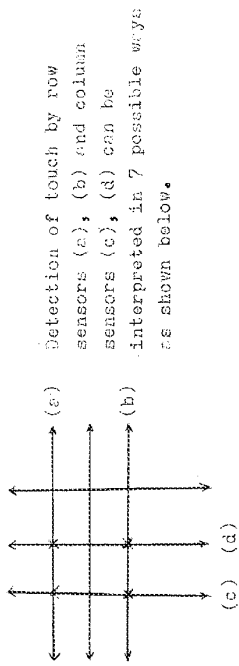

FIG. 2.7 Possible sets of points whose existence may be implied by two sensors on both row and column.

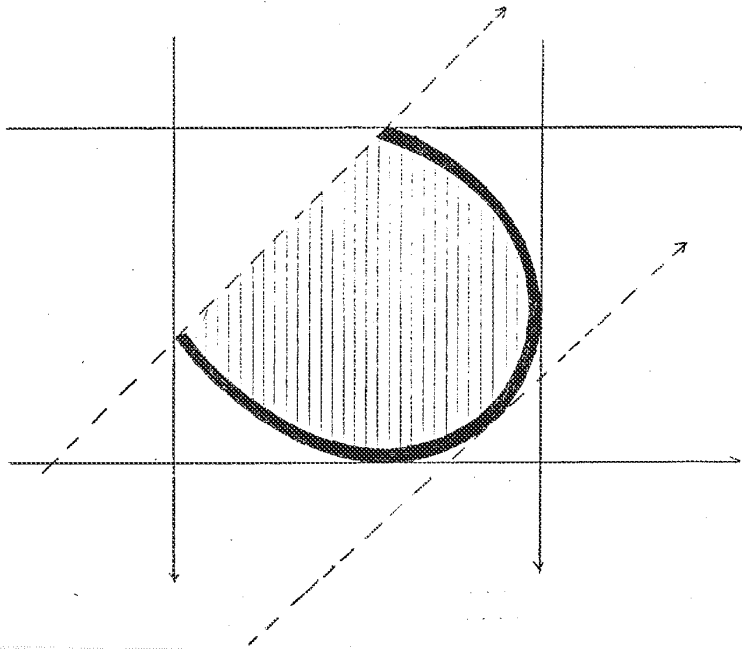

Fig. 2.8 Concave touch points that block the points inside.
Any point or group of points within the shaded
region cannot be identified by any number of
projections.

2.4 APPROACHES TO THE PROBLEMS

One concludes from the previous discussion that existing systems and devices do not provide an appropriate means to reach our goal. The major problem of the projective sensor is generally the ambiguity on multiple points. As a solution to this problem, multiple axes are required. This however, increases the cost as well as the number of points to be scanned. Furthermore it cannot eliminate the ambiguity within regions of "concave touch points" using any reasonable number of axes. On this basis, all projective methods must be discarded.

One idea of some significance that can be introduced is to avoid scanning all the pixels in the tablet which contain no information. For example, scanning all 2048 points of a tablet having a resolution 64 by 32 for fewer than 10 points is really quite a ridiculous approach. In fact, if the number of the points to be searched is comparably small, then an improved algorithm, here called binary scanning, can be used. It is described as follows.

Consider a plane of a tablet with resolution 8 by 8 to be searched for a touch point as shown in the Fig. 2.9. First, check the tablet for touch as a whole region as shown by the area ABCD in the figure. If touch is detected, divide the tablet into two equal regions shown by the line EF and check each of the two regions ABEF and EFCD for touchness.

Select the touched region, region EFCD in this case, and divide this into two equal regions as shown by the division line GH, selecting the touched region. Continue this process until no further division is possible, that is, until a unit sensor, designated as the region FKMO in Fig. 2.9, is reached. The figure also shows the sequence of subdivision in the binary scanning operation. More details of this algorithm are given in chapter 4.

Using this algorithm, a search for one point on a tablet having a resolution 64 by 32, requires twenty two scanning times:

$$2 * \log_2(64 * 32) = 22$$

If there is no overhead in binary scanning and scanning begins at the "top of the tree" (that is, with a region in which all pixels are grouped together), then using binary scanning, the number of touched points that can be identified in the time that it would take to detect one touch if all pixels are scanned one by one linearly is

$$\frac{64 * 32}{22} = 186.$$

This shows immediately that the binary scanning method is much superior to linear scanning if the number of points to be scanned is fewer than 186.

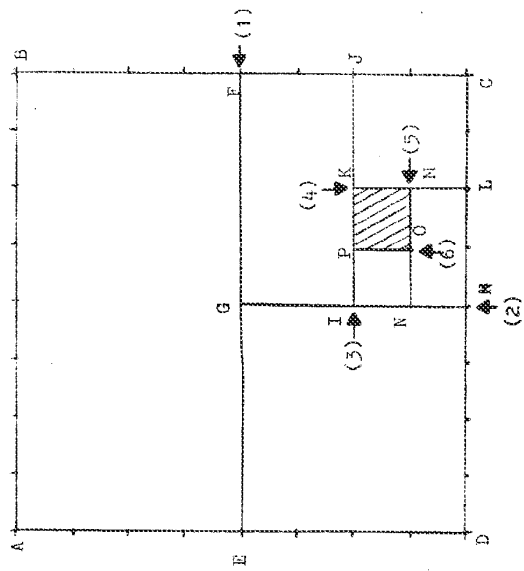

FIG. 2.9 Binary scanning operation.
 (n)-Sequence of subdivision in binary operation.

For example the speed gain over linear scanning when the number of points is ten is

$$\frac{64*32}{22*10} = 0.3$$

That is, for 10 points binary scanning is about 9.3 times faster than linear scanning.

Now compare such a 64*32 binary scanning tablet with a 2-d projective touch tablet such as used in the HP Personal Computer Input Screen, or with the capacitive single touch tablet with 64 by 32 resolution. In each case the speed gain for detection of a single touch is

$$\frac{64*32}{22} = 4.36$$

or about 4.3. That is, the binary scanning tablet is potentially 4.3 times faster than one for which only sequential scan is possible.

Even if the binary scanning algorithm is applied to the projective tablet, the speed for the projective tablet will not exceed the speed of the 2-d image tablet. The scanning time for a projective tablet having the same resolution is found as follows; Since there are 64 + 32 sensors only, and the binary scanning algorithm is applied to the row and the column sensors separately, the scanning time is

$$2 \cdot \log_2(64) + 2 \cdot \log_2(32) = 22$$

Thus the binary scanning algorithm seems to be a very attractive one for application to the FMTSID. However it necessitates two special hardware features:

1. Unlike the projective sensor system which allows to address only a group of positions in a column or a row, all individual positions of m by n tablet should be addressable.
2. It should be able to group a number of adjacent sensors as one larger sensor region.

The first requirement is to permit sensing of multiple touches, the second allows for the binary scanning algorithm. In addition to these necessary features, a measure of the intensity of touch should be considered as a third requirement to increase the capability of the FMTSID.

The sensors that can possibly accommodate these requirements are many. However the degree of difficulty in implementation varies one to another. In the following, various sensor types are examined in view of the requirements identified above.

A resistive image sensor can be used with a slight modification of the multiplexor as shown in the Fig. 2.11,

however far too much time is required to evaluate the resistance using two port parameter calculations. Besides, the basic approach requires that all the row resistances have to be evaluated once using linear scanning; that is, binary scanning is not applicable to rowwise scanning.

For the video system, the row and the column scanning registers are not accessible and with the video data stored in memory, it is not possible to satisfy the second requirement. However the third requirement may be met by the addition of a little more hardware. In general, therefore, it is not a good choice.

None of the other devices presented in the previous section satisfy the requirements. Thus it is necessary to identify further sensor types.

A resistive polymer (J.S.R) was examined [ref 2.7]. The polymer changes resistivity with applied pressure. One of the applications shown by J.S.R has two closely-placed, but separated, metal coated plates on the PC board on which the rubber sheet lies such that if the rubber is pressed down, the two plates are connected. This unit may be used with a lot of multiplexors to select one of all sensors on the board. However a problem with this sensor is that it takes a very long time for the material to recover electrically to the original state after the finger is released (about 100 msec).

Piezoelectric material was also examined. One possible approach is to apply the same hardware technique used in keyboard applications. However this approach does not eliminate the multiplexing problem. Unfortunately during the time required for multiplexing, the charge developed by the impact of the touch can be lost.

Finally, it seemed that the capacitive sensor offered the greatest potential of all available approaches for the following reasons:

- 1. Capacitive sensors do not need additional equipment, that is, the basic insulating sheet and touch plate are sufficient.
- 2. Multiplexors for individual sensors can be avoided or are degenerately simple using row and column addressing methods described in chapter 3
- 3. Capacitive sensors can accommodate all three features identified above. In particular, a measure of intensity is available since the area of finger contact and corresponding capacitance increases with finger pressure.
- 4. Capacitive sensors are very durable since no additional elements are needed and there is no recovery

time phenomenon involved as exists with resistive rubber.

However there are some drawbacks to capacitive sensors. First they require time to charge and discharge. However these times can be reasonably well controlled. The second drawback is that a capacitive sensor generates radio frequency noise when the tablet is touched. The third drawback is low resolution. However the low resolution can be compensated by software technique as discussed in chapter 4. Noise in the radio frequency spectrum, which is potentially a problem in some environments, does not deteriorate the operation of the tablet. Since level of the noise could not be known at the time of design, it was not considered as a factor in the choice of sensor.

2.5 CONCLUSION

In this chapter, several kinds of touch sensitive input device have been examined as a part of the process of developing a flexible multi-purpose input device. Many devices and sensor types have been analyzed from different points of view in order to achieve the desired goals.

With respect to the initial goals of developing a flexible multi-purpose input device, it seems that the touch tablet as conventionally defined, does not fulfill the

requirements of flexibility and adaptability, but rather that a fast multiple touch sensitive input device (PMTSID) must be pursued to meet the real requirements.

In order to reach this goal, capacitive sensor based hardware with a binary scanning algorithm was chosen for development.

CHAPTER 3

HARDWARE DESIGN AND IMPLEMENTATION

3.1 INTRODUCTION

This chapter describes the details of the hardware implementation of a fast multiple-touch-sensitive input device (FMSID). The design of the hardware is based on the hardware requirements identified in the previous chapter and on tradeoffs between software and hardware. The hardware basically consists of a sensor matrix board, row and column selection registers, A/D converting circuits and a dedicated CPU.

The design of the sensor matrix is based on the technique of capacitance measurement between a finger tip and a metal plate. Row selection registers select one or more rows by setting the corresponding bits to a high state in order to charge up the sensors while the column selection registers select one or more columns by turning on corresponding analog switches to discharge the sensors through timing resistors. The intersecting region of the selected rows and the selected columns represents the selected sensors as a unit. A/D converting circuits

measure the discharging time interval of the selected sensors. A University of Toronto 6809 board was used as dedicated CPU.

The details of the sensor matrix design are given in section 3.2, with the rest of the hardware described in section 3.3. Section 3.4 describes the scanning sequence used in conjunction with the hardware development process while section 3.5 concludes with a description of the hardware implementation.

3.2 THE SENSOR MATRIX

The design and construction of the sensor matrix board is straightforward. The touch surface of the sensor board consists of number of small metal-coated rectangular-shaped areas serving as sensor plate capacitors. The design of the metal plate area of a unit sensor depends on the measurable capacitance change that results when the area is covered by a finger tip, and on the resolution that can be implemented.

A 12" by 16" sensor matrix area with a resolution of 32 by 64 was chosen, resulting in 7 mm by 4 mm area for each sensor. The estimated capacitance between the sensor plate and a touching finger separated by 3 mil (0.075 mm) Mylar insulating coversheet is

$$C_s = \epsilon \frac{A}{d} = 3 \times 8.85 \times 10^{-12} \frac{7 \text{mm} \times 4 \text{mm}}{0.075 \text{mm}} = 10 \text{pF}$$

where ϵ is the dielectric constant of the insulating coversheet, A is the area of the unit sensor and d the thickness of the insulating sheet.

The charge associated with the touch capacitance is stored between the sensor plate and the touching finger acting as ground. For this purpose human beings can be considered to be a large charge reservoir. For the static charge case, a suitable model of a human being is an approximate 100 pF capacitor with one plate connected to ground. [ref 3.1] Therefore, it is safe to assume a touch as ground reference for measurement of relatively small capacitances.

The 10 pF of sensor capacitance change is relatively small but measurable. For a timing resistor of 100 k, the time change due to the sensor capacitance change is about 1 micro-second. The tradeoff between the time taken for the measurement of the capacitance and the ease of measurement seems to be obvious. If the capacitance is high, it is "easy" to measure but it takes longer, slowing down the scanning procedure. The clock cycle used to count the discharging time is also limited by noise in the analog circuits as well as by timing limitations of the TTL circuits used. With these limitations in mind, the period of the counter clock was chosen to be 100 nano-seconds.

In order to select a sensor by row and column access, two diodes were used for each sensor. One diode, connected to the row line, is used to charge up the sensors in the row. It is referred to as the Charging Diode (CD) as shown in Fig. 3.2. The CD also serves to block the charge flowing back to the row line when the row line voltage is dropped to zero. The other diode called the Discharging Diode (DD), connected to the column line, enables discharging of the selected row sensors to a virtual ground. Also the DD blocks charge flow from the sensors in the selected row to the sensors in the unselected row during the discharging period. The selection of rows, by the row selection procedure, causes the sensors to be charged. The sensors in the column are then discharged through associated timing resistors connected to the column selection switches.

Fig 3.1 (a) shows the components associated with a selected sensor. There are two related time periods: One for the selection of rows (that is, the charging period) and the other for the selection of columns (that is, the discharging period). The capacitance is measured while the sensor discharges. The signal output during discharging is shown in Fig. 3.1 (b).

Analytic equations can be derived for the model assuming that the reverse diode resistance is much higher than the discharge resistor R and the forward resistance is much

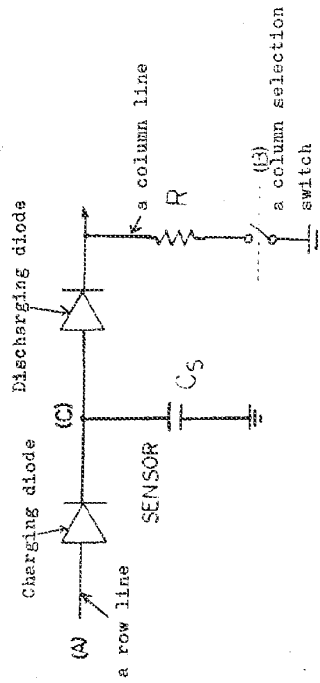

Fig. 5.1 a. A model of a selected sensor in the sensor matrix

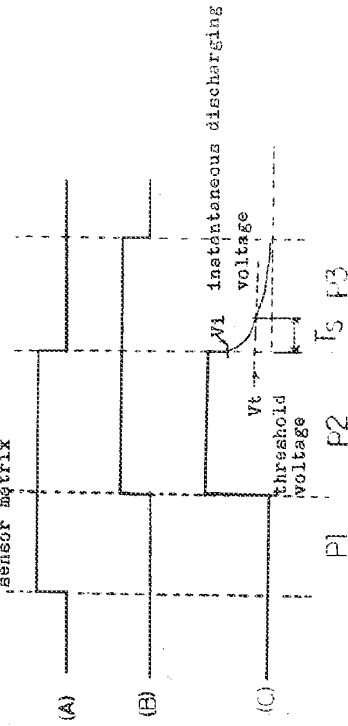

Fig. 5.1 b. The timing diagram for discharging time measurement of a selected sensor as shown above.

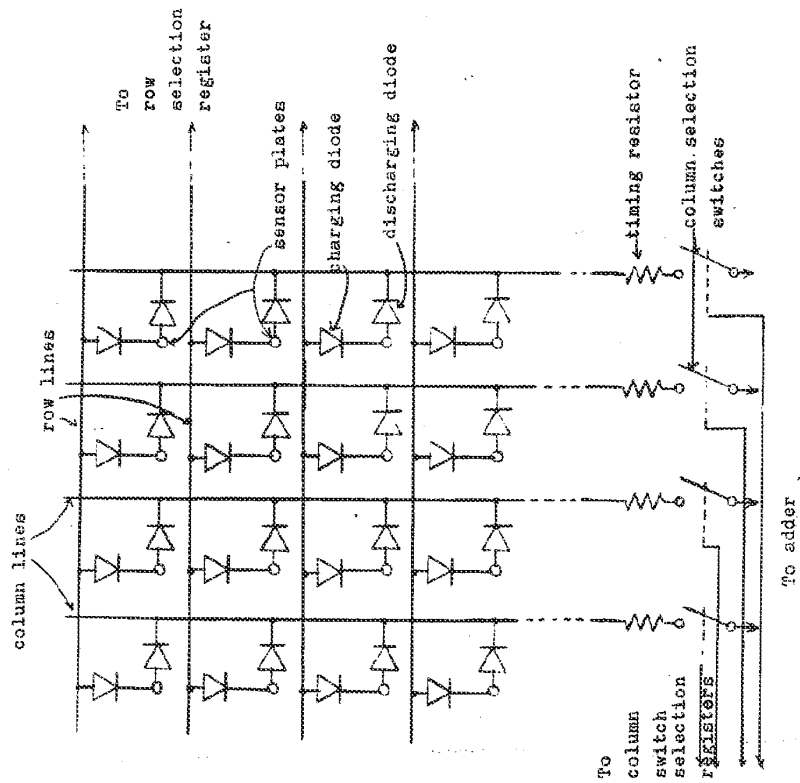

Fig. 3.2 A small section of sensor matrix.

smaller than the discharge resistor R. The derivation is as follows.

The discharging voltage (V) is given by

$$V=V_i \cdot \exp\left(\frac{-t}{T}\right)$$

where V_i is the instantaneous initial voltage of the discharging period and T is the time constant.

T is given by

$$T=R(C_s+C_r)$$

where C_s is the sensor capacitance and C_r is the reverse bias capacitance of the diode.

The voltage V_i can be found from

$$V_i = \left(\frac{C_s}{C_s+C_r} \right) \left(\frac{Q_s-Q_f}{C_s} \right) (V_{cc}-V_d)$$

where Q_s and Q_f are respectively the charges stored in the sensor and the forward biased diode just before the discharging period begins, and V_{cc} and V_d are respectively the high state voltage for CMOS and the diode voltage drop. In the equation for V_i , the first factor is associated with charging up a reverse biased diode while the second factor results from the charge in the forward biased diode stored

during the charging period.

The discharge time is measured by the comparison with a threshold voltage (V_t) and it is given by

$$T_s = T_{in} \left(\frac{V_t}{V_i} \right)$$

From these analytic equations, the following conclusions relating to the selection of appropriate voltage levels and the diode type can be made.

1. The higher the V_{cc} , the less sensitive is the measurement to the threshold voltage at $V = V_t$ where the $V = aV_{cc}$ and the sensitivity, that is the derivative of V with respect to t , is $-aV_{cc}/T$.
2. The smaller the reverse bias diode capacitance, the higher the resulting V_i and the less time it takes to measure the same sensor capacitance.
3. The smaller Q_f can be made, the higher V_i will be.

The first implication is the choice of CMOS logic to interface the sensor matrix using high logic voltages with V_{cc} equal to 15 volts. To use CMOS logic directly connected to the sensor board which is prone to high static voltage from touch, the circuitry must be protected. High negative voltage bypass diodes are connected to each row

line(charging source) for this reason.

The second implication is the use of diodes with small reverse capacitance. The diode 1N 4148 was chosen for low capacitance, low cost, and availability. The reverse bias capacitance of this diode is specified as 4 pF.

The third implication relates directly to the forward current of the diode since $Q_f = C_f * V_d = k * I_d * V_d$, where C_f is the forward capacitance, V_d is the diode voltage drop, I_d is the diode forward current and k is some constant. Furthermore, since $I_d = (V_{cc} - 2 * V_d) / R$, the I_d selected is then interrelated with the timing resistor chosen.

Further analysis of the sensor matrix is of interest: there are 2048 such unit sensors implemented on the P.C board. Accordingly the analysis is rather complicated because the rows and columns are electrically not completely separated. A small section of the sensor matrix configuration is shown in Fig. 3.2 for illustration. The reverse bias capacitance couples the sensors in a column. Moreover there exist capacitances between columns due to the physical configuration of the sensor plates and wires and due to the parasitic capacitances in the circuit, and these couple the sensors in a row. The first of these coupling is seen to be unavoidable while effort was taken to reduce the second.

A simple column sensor array has been analyzed as

shown in appendix A. Only the results will be discussed here. The analysis is based on an effort to obtain V_i , the instant initial voltage in the discharge period, r , the ratio of the sensor capacitance over the surrounding capacitance, and m , the separation parameter in the rows.

The instantaneous discharging voltage V_i for a case when a selected sensor is touched, is given by

$$V_i = \frac{st^{*}0.5^{*}(n-1) - f^{*}b}{st^{*}0.5^{*}(n+3)} (V_{cc} - 2^{*}V_d)$$

where $a = (V_{cc} - V_d) / (V_{cc} - 2^{*}V_d)$, $b = V_d / (V_{cc} - 2^{*}V_d)$, $f = C_s / C_r$, and $st = C_s || C_t / C_r$.

The ratio of the sensor capacitance to the intrinsic capacitance of the surroundings, r , is

$$r = \frac{st}{\frac{n+1}{2} + st}$$

The separation parameter m is the number of non-selected sensors which must be touched, to cause a non-touched, but selected, sensor to report as "touched". Appendix A shows equations for derivation of this parameter and its evaluation by computer iteration in terms of variables such as the ratio of C_s / C_r and C_t / C_r . When $C_s / C_r = 2.5$ and $C_t / C_r = 12.5$, the separation parameter m is about 8, and when C_s / C_r

≈ 5.0 and $Cf/Cr = 12.5$ the m is about 25. The first result implies that if more than 8 sensors are touched in a column, then the result will be a wrong report that all the sensors in the column have been touched. The second result implies that if more than 25 sensors are touched in a column, the result will be a report that all the sensors in the column have been touched. Nevertheless, all of the analysis for the single selected sensor model is still valid with some complication.

The analysis becomes more complicated when the parameters for rows and column are included in the equations. Since the operational amplifier adds currents from selected columns and consequently the discharging time increases by $1 + \ln(2)/a$, where $a = \ln(Vi/Vt)$, when the number of columns increases by factor of two, the reference values are expected to be increased by the factor of 1.57 for $a = \ln(10/3) = 1.2$ correspondingly. However, an increase in the number of rows in a group is not expected to increase the reference values because the charge stored in the non-selected reverse bias diodes becomes smaller whereas the charge stored in the selected forward bias diodes remain constant during charging period and consequently Vi becomes smaller.

Efforts have been made to separate the columns as much as possible. However there still will be some coupling capa-

circumstances between columns due to physical adjacency; but their effects are considered to be minimal.

3.3 INTERFACE CIRCUIT DESIGN AND IMPLEMENTATION

Interfacing between the sensor matrix and the dedicated CPU requires three main circuit blocks: row selection registers, column switch selection registers and A/D converting circuits. The CPU selects the row or rows of a sensor group, initiating charging of all the associated sensors. After a charging interval, the CPU discharges the selected column or columns corresponding to a sensor group by connecting a group of discharge resistors whose current is summed via a high slew rate operational amplifier.

There is tradeoff between the scheme using a single bit for each row and one using decoding circuits to implement binary addressing suited to the binary scanning algorithm. The bit per row scheme requires 32 bits of register while binary coding needs 6 bits of register since only $32 * 2^{-1}$ patterns of sensor grouping exit according to the binary scanning algorithm. However, the first scheme was chosen because it is ultimately flexible, that is, it allows one to implement "all" scanning modes by means of software. Thus changes can be easily made in the case of difficulty with implementation of a particular software algorithm. The

implemented prototype uses four 8 bit registers with a common reset signal for row selection.

For the same reasons sufficient column switch selection registers are provided so that one can generate any group pattern through software. However, to reduce the number of chips on the board, four switches are controlled by each bit resulting in four simultaneous analog signals and necessitating four counters. However as a result only 2 8-bit latches are needed to control 64 switches. The four sets of data are provided to the CPU after each scan. These data are manipulated by software in correspondence with the selected resolution mode. This implies the hardware itself acts as an array of 32 by 15 bits while the software emulates 32 by 64 bits of scanning resolution. The scanning algorithm is explained in chapter 4.

The charges stored in the selected row(s) flow down through the selected switches to the virtual ground of the fast operational amplifier. All the discharging currents are correspondingly added to produce a signal from which the discharging time of all the selected sensors can be found by comparison with a threshold voltage. The output of the negative voltage comparator is fed to the enable signal of the counter and to the data bus as a status bit for the counter readiness. All the counters are reset when the row selection registers are deselected in order to initiate the counting

greater number of bits is found to be necessary. The 8 bit counter enables the measurement of a 7 bit capacitance change regardless of the degree of overflow in the counter. This means that if the difference, touched to non-touched, does not exceed 127, the difference can be obtained without ambiguity. For example, a counter value 4 is larger than 18 if the difference is less than 7 $\frac{1}{2}$ in hexadecimal; in other words, an unsigned 8 bit comparison would not be appropriate. Therefore the counter does not need to accommodate the entire discharging time including the time due to the surrounding capacitance, which may require more than 8 bits. Some manipulation is done in software to utilize the facts above. A complete analysis is given in appendix B.

The remaining circuits are for shifting CMOS levels to TTL level and for decoding addresses. Eight addresses are decoded with a R/W signal. One write address is used for a single register whose output controls the discharge of all the sensor matrix at once, the grounding of the ground strip on the board for template recognition applications as described below, and as well as controls three LED outputs.

A metal strip is located on one side of the touch surface of the board. This strip is a programmable ground strip which can be grounded to allow a metal-coated pattern on the back side of the template shown in Fig. 3.3 to be scanned. It can be ungrounded for normal binary scanning so

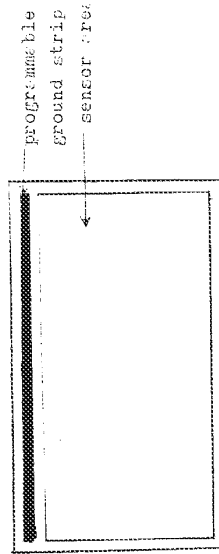
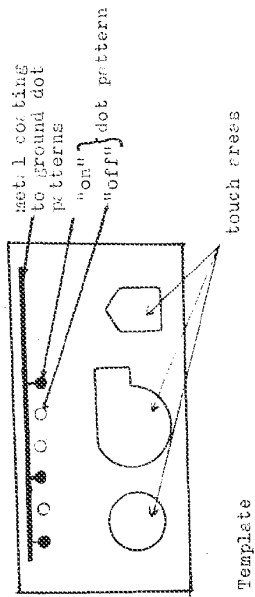

Fig. 3.5 Template and touch sensitive tablet.
 The template pattern lies on the sensor area.
 Its metal coating touches the ground strip
 which is grounded to initiate recognition of
 the template.

that the "touch" by the pattern can be ignored. Otherwise it increases the time to scan all the points on the touch surface including the unneeded points from the template because the binary scanning time is directly proportional to the number of points on the tablet.

3.4 THE HARDWARE SCANNING SEQUENCE

This section describes the reading sequence for data from the sensor matrix board. A block diagram of the hardware circuit is shown in fig. 3.4 to assist the reader. The sequence is as follows.

- 1. Reset the row selection registers. That is, ground the inputs to the sensor matrix.
- 2. Discharge all the sensors directly to ground (out not through R) for about 2 microseconds.
- 3. Select the row selection registers with an appropriate bit pattern.
- 4. Select column switches by turning on the appropriate bit pattern in the column switch selection registers about 4 micro-seconds to stabilize the sensor charge.
- 5. Reset the row selection registers and the the output counters together to initiate counting of the discharge

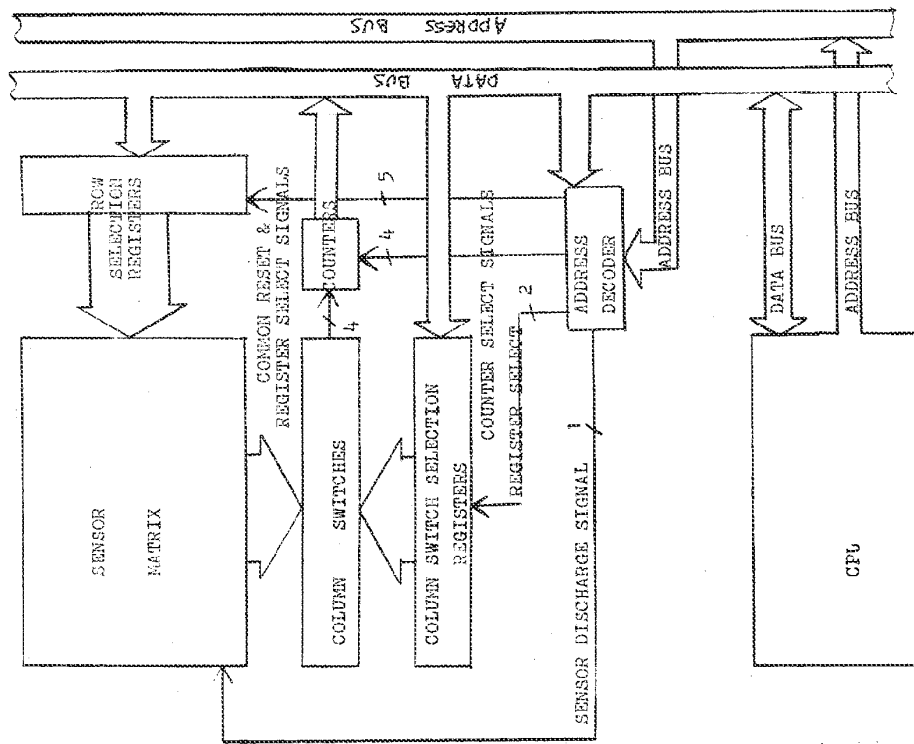

Fig. 3.4 Block diagram of the hardware.

ing time.

--- 6. Wait until the counters are ready by reading the status bits.

--- 7. Read the counters.

The bit patterns in the row selection register and in the column switch selection register represent the row and column addresses respectively. These, however, have to be converted to a convenient form corresponding to physical placement which is understandable to the user or to the interfacing routine. This process is described in the next chapter.

3.5 CONCLUSIONS

In this chapter, tradeoffs between software and hardware have been discussed while introducing the design of the sensor board and its interfacing circuits. A prototype tablet has been implemented and tested. There were difficulties but all have been surmounted. The detailed results of performance testing are described in the chapter 5.

CHAPTER 4

ALGORITHMS AND SOFTWARE STRATEGIES

4.1 INTRODUCTION

In this chapter, the software tasks to be performed and details of the algorithms developed are described.

The first task is that of grouping sensors such that a variety of scanning algorithms are allowed so that the flexibility of the hardware is not lost. Definitions of various resolution modes and sensor grouping structures are described in section 4.2. In section 4.3 the address mapping between the physical location and its reference memory address, and bit patterns of the row and column selection registers for all possible groupings of sensors, are defined.

The second task is to reduce the digitization noise of the discarding time, and to identify a touch on the sensor matrix using the threshold method. These processes are described in section 4.4. Section 4.5 details the scanning algorithms. In section 4.6, a few interpolation schemes are described whose purpose is to compensate for the low resolu-

tion of the hardware.

Employing these algorithms and tasks, section 4.7 indicates the programs in the host computer and the dedicated CPU are organized. Finally this chapter is summarized in section 4.8.

4.2 SENSOR GROUPING STRUCTURE

In this section, various groupings of sensors in both column and row directions are defined in such a way that the implementation of most algorithms and software strategies is permitted. Corresponding bit patterns in the column and row selection registers are established for a number of groupings of sensors and their physical locations. From the hardware standpoint, there are many possible groupings of sensors that are appropriate. However, there is limitation to implementing all possibilities because of the corresponding reference value storage requirement.

Amongst many possible ways to group the sensors, one that permits easy implementation of all the algorithms in the dedicated CPU, is a rowwise or columnwise binary tree structured grouping. This grouping allows groups of 1, 2, 4, 8, etc in row or in column. Fig. 4.1 shows the grouping scheme in a binary tree structured way for sensors in an 8 by 8 tablet. In order to describe the bit patterns and

reference value data structures in a later section, a notation that represents a unique group of sensors on a tablet is necessary. In support of this notation the coordinates of column level and address, row level and address are introduced as shown in Fig. 4.1.

Level 0 implies that all sensors are grouped into one row or column, Level 1 represents grouping all sensors in a row or column into two equal parts. Level 2 implies grouping all sensors in a row or column into four equal parts. The position of a group of the sensors in the same level, is described by a corresponding row or column address. The relationship between row/column address and level is shown in Fig. 4.1.

For example, row level = 2, row address = 1, column level = 3, and column address = 3 describes the group of sensors in the shaded region (A) in Fig. 4.1. The group of sensors in the region (B) is given by the coordinates (column level, column address, row level, row address) = (1,1,2,3).

This grouping structure, however, does not allow arbitrary location of a group of sensors on the tablet; even though the number of sensors can be grouped by 1, 2, 4, etc, groups cannot overlap each other in a row level and column level other than their own. Otherwise the grouping structure provides many useful features. For example the

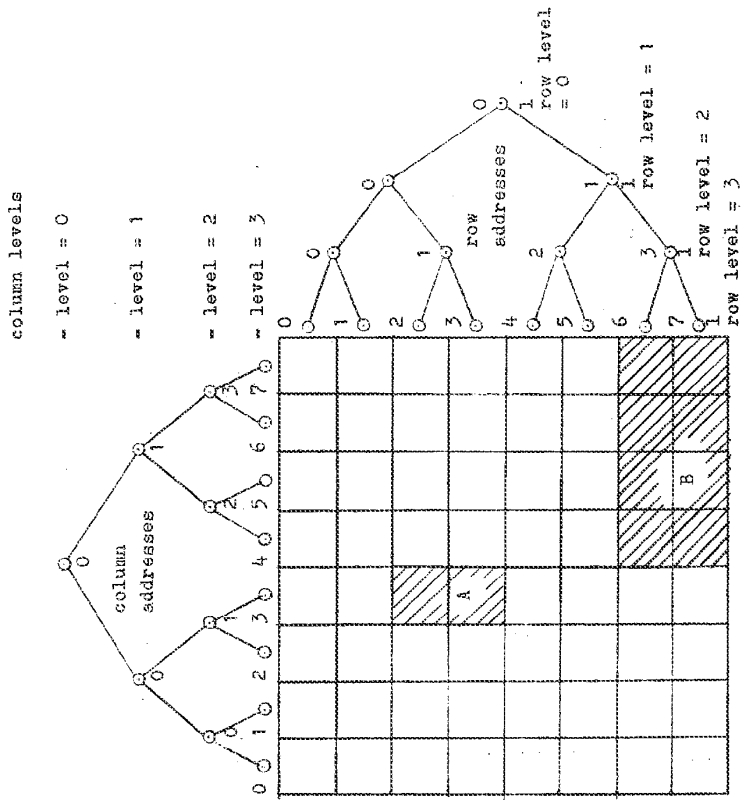

Fig. 4.1 Grouping the sensors in two binary-structured ways for an 8 by 8 sensor tablet.

A group of sensors is described by 4 coordinates (column level, row level, column address, row address). For example, the sensors in the shaded regions A and B are designated by (3,2,3,1) and (1,2,1,3) respectively.

groupings needed for the binary scanning algorithm are shown in Fig 4.2 in order to display the relationships between the nodes in the "tree" and the corresponding physical location on the tablet. This arrangement utilizes a part of the grouping structure implemented.

4.3 BIT PATTERNS IN THE SELECTION REGISTERS AND ADDRESS

MAPPING

The bit patterns in the row and column selection registers are directly related to the groupings of the sensors. A group of sensors corresponding to (column level(cl), column address(ca), row level(rl), row address(ra)) have a unique bit pattern in the row and column selection registers. It is given by

$$bp = a(0) a(1) a(2) a(3) a(4) \dots a(i) \dots a(n-1)$$

where $a(i)=1$

for $i = \{ i \mid \text{num_bit} * \text{ra}(\text{or ca})$
 $\leq i < \text{num_bit} * (\text{ra}(\text{or ca}) + 1) \}$

otherwise $a(i)=0$.

And where the num_bit is defined to be
 $2^{(\text{maximum_number_of_levels} - \text{rl}(\text{or cl}))}$

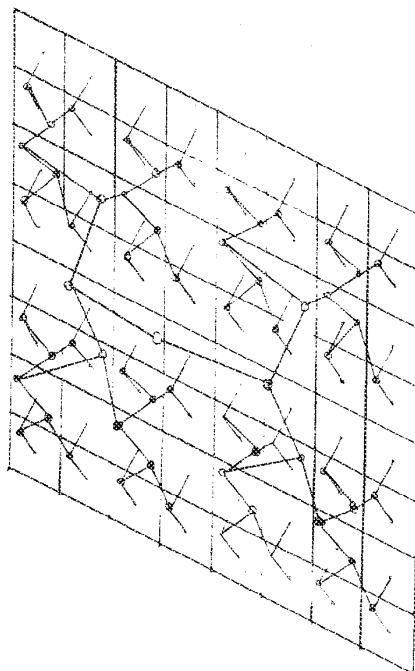

Fig. 4.2 Grouping of an 8 by 8 sensor array for the binary scanning algorithm. Each node in the "2-d tree" represents a grouping of all the sensors or nodes below.

and n is the number of sensors in a row or column. The total number of grouping levels of a tablet with resolution (r by c) is given by

$$\lceil 1 + \log_2(r) \rceil * \lceil 1 + \log_2(c) \rceil$$

In particular, for the prototype, the number of grouping levels is 42, that is

$$\lceil 1 + \log_2(64) \rceil * \lceil 1 + \log_2(32) \rceil = 42$$

In other words, there are 42 different sensor groupings

Since the total number of nodes in a "perfectly balanced" binary tree with bottom level number n, is given by

$$(2 * 2^m - 1),$$

the total number of combinations of nodes in the row and column, having bottom levels m and n, is given by

$$(2 * 2^m - 1) * (2 * 2^n - 1) = 4 * 2^{m+n} - (2^m + 2^n) + 1$$

Thus since each combination of row and column nodes requires a reference value, the storage required for the total grouping structure is almost four times as great as the number of sensors on the tablet. This results in a storage for reference values in the prototype of about 8k bytes.

Reference memory address mapping is shown in the FIG 4.2. The reference address is obtained from the row and

column addresses and the row level and column level values. The conversion from one to the other is very simple in assembler and access is more rapid than if pointers were used.

The masks for all grouping levels in both row and column addressing, as shown in Fig. 4.3, use bit stuffing in front of the row and column addresses to identify a group of sensors uniquely at all levels. Since only one more bit is needed to represent the addresses of any node as well as any leaf in a tree, the number of address bits required by the reference address generation scheme shown in Fig. 4.3 for a tablet of resolution m by n , can be seen to be

$$\log_2(n) + \log_2(m) + 2$$

For the prototype whose resolution is 64 by 32, the requirement is 13. Therefore, the address mapping scheme uses a full 8k spaces whereas the requirement as provided above is for a little less than 8k bytes. Nevertheless, it is very close to the maximum usage and the scheme is very efficient.

4.4 NOISE REDUCTION

The capacitance values vary with spatial arrangement as well as with grouping level. In order to remove the variation on capacitance discrepancy over the spatial arrange-

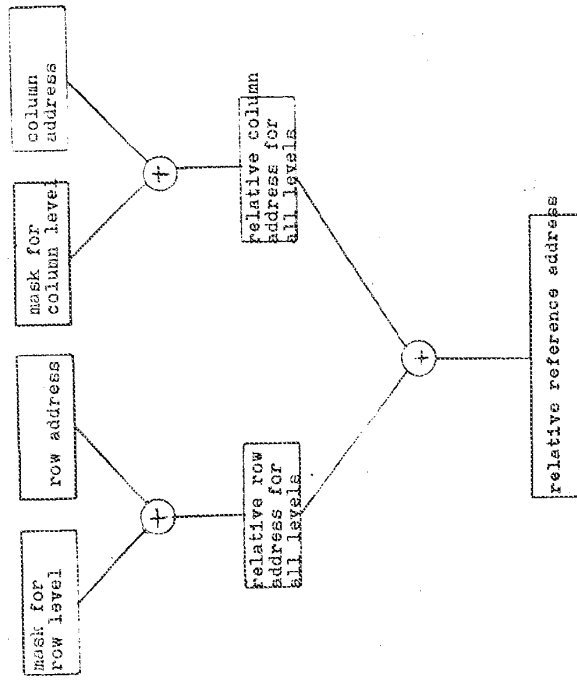

FIG. 4.3 Reference address mapping from a physical address consisting of row and column addresses.

ment, reference values are obtained for the untouched tablet and stored during the initialization period. After initialization the data are then obtained by subtraction of the reference value from the current value. This process eliminates the spatial noise embedded in the sensor circuits.

The value obtained from a group of sensors still contains various time dependent noise signals originated in the analog circuits as well as the noise corresponding to variations in touch. Therefore it cannot be used directly. To reduce the effects of time varying noise, the CPU reads the same group of sensors many times and an average is used. The process of averaging involves the overflow of an 8-bit register as described in appendix B. The averaged datum is then compared with a threshold for its row and column levels to detect touchedness. The expected level of noise varies with the grouping level. Therefore each combination of row and column levels has a threshold. The thresholds are obtained either through direct input from the user or by a process of automatic threshold setting which is performed during the initialization period.

Another approach to reducing the noise is a scheme relying on spatial arrangement. This method is applied only for the interpolation of a number of touched sensor values. The basic idea is that pixels remote from the touched sensor can be weighted to reduce the noise to signal ratio.

4.5 SCANNING ALGORITHMS

Three scanning algorithms were considered and implemented. They are linear scanning, modified linear scanning and binary scanning. With the linear scanning algorithm, the CPU scans the tablet one physical sensor at a time. The modified linear scanning algorithm is based on the fact that the tablet can be configured as to emulate a projective sensor. First the CPU searches for a touched row and, then only the touched row is divided into many columns for detecting individual sensor locations. The binary scanning algorithm has been introduced in the chapter 2. The details of the scanning processes in C language description follow.

```
    touched(difference)
    int *difference; /* return value of the scanning a pixel */
    {
    current = readdata();
    *difference = current - reference;
    if (*difference > threshold)
        return ( true );
    else
        return ( false );
    }

    linear scanning
    ls(level,levelc)
    int levelr, levelc; /* input to define the resolution */
    {
    int limitcoladr, limitrowadr, coladr, rowadr;
    limitcoladr = 2 << levelc;
    limitrowadr = 2 << levelr;
    for ( coladr = 0; coladr < limitcoladr; coladr++)
    for ( rowadr = 0; rowadr < limitrowadr; rowadr++)
    {
    rowbitpattern = getbitpattern(levelr,rowadr);
    colbitpattern = getpattern(levelc,coladr);
    reference = getreference(levelr,levelc,rowadr,coladr);
    }
```

```

if ( touched(sz))
  report(rowadr,coladr,z);
}
}

modified linear scanning
ms(level, levelc)
int level,levelc;
{
  limitcoladr = 2 << levelc
  limitrowadr = 2 << level
  for(rowadr=0; rowadr < limitrowadr; rowadr++)
  {
    threshold = getthreshold(level,0);
    colbitpattern = getpattern(0,0);
    rowbitpattern = getpattern(level,rowadr);
    reference=getreference(level,0,rowadr,0);
    if (touched(sz))
    {
      for(coladr=0; coladr<limitcoladr; coladr++)
      {
        threshold = getthreshold(level,levelc);
        rowbitpattern = getpattern(levelc,coladr);
        reference = getreference(level,levelc,
          rowadr,coladr);
        if (touched(sz))
          report(rowadr,coladr,z);
      }
    }
  }
}

```

binary scanning

```

bs(coladr, rowadr, level, levelc)
int rowadr, coladr, level, levelc;
{
  rowbitpattern = getbitpattern(level,rowadr);
  colbitpattern = getbitpattern(levelc,coladr);
  reference=getreference(level,levelc,rowadr,coladr);
  if ( touched(sz))
  {
    if((level==limitlevel)&&(levelc==limitlevelc))
      report(rowadr, coladr, z)
    else
      bs(coladr<<1, rowadr<<1, levelc+1, levelr+1);
  }
  else
  {
    if((levelr==limitlevelr)||((levelc!=limitlevelc)

```

```

for(i=0; i<3; i++)
switch(i) {
case 0: bs(coladdr+1,rowadr,levelr,levelc);
break;
case 1: bs(coladdr,rowadr+1,levelr,levelc);
break;
case 2: bs(coladdr+1,rowadr+1,levelr,levelc);
break;
default: break;
}
}
}

```

The binary scanning algorithm is actually implemented in assembler in a non-recursive way; however the structure and the algorithm have not been changed from the representation above. This algorithm and the modified linear scanning algorithm are very sensitive to the values of the thresholds for each level. Thus detecting very small contact areas over a large sensor group area is rather difficult. Accordingly if the threshold for the top level is high then a small intensity of touch may not be detected; whereas if it is low, then the search may not be successful. Consequently this would slow down the scanning procedure since a large number of unsuccessful tries at the bottom level (caused by low threshold in the higher levels) delays the scan of the actual touch points.

4.6 COMPENSATION FOR LOW RESOLUTION HARDWARE

It may seem that the resolution of the hardware is too low for use in graphics applications. However touch

intensity and multi-touch sensitivity can be used to enhance resolution. This is possible because the center of a touch can be most accurately estimated by an interpolation utilizing the values of the adjacent sensor intensities. For a simple example, consider the estimation of the center of the touch by an interpolation method as follows:

Suppose the touched point is (i,j) and its intensity value is $z(i,j)$. Let the dx and dy be the relative position of the interpolation to the integer position (i,j) . Then the dx , and dy can be obtained from the values of the adjacent intensities as follows.

$$dx = \frac{\sum_k (-1, +1) (z(i+k, j+1) - z(i+k, j-1))}{\sum_k (-1, +1) \sum_k (-1, +1) (z(i+k, j+1))}$$

$$dy = \frac{\sum_k (-1, +1) (z(i+1, j+k) - z(i-1, j+k))}{\sum_k (-1, +1) \sum_k (-1, +1) (z(i-k, j+1))}$$

Thus the estimated center of touch is $(i+dx, j+dy)$.

A simple case is shown in Fig 4.5 where possible interpolation points are shown when 1, 2, 3, 4, or 5 bits of intensity are provided from two adjacent sensors. The picture shows that interpolation points are not evenly populated and that the scheme does not give good resolution even if a fairly high number of intensity bits are provided. Therefore it may be good idea to map each interpolation point to another domain which gives evenly populated points

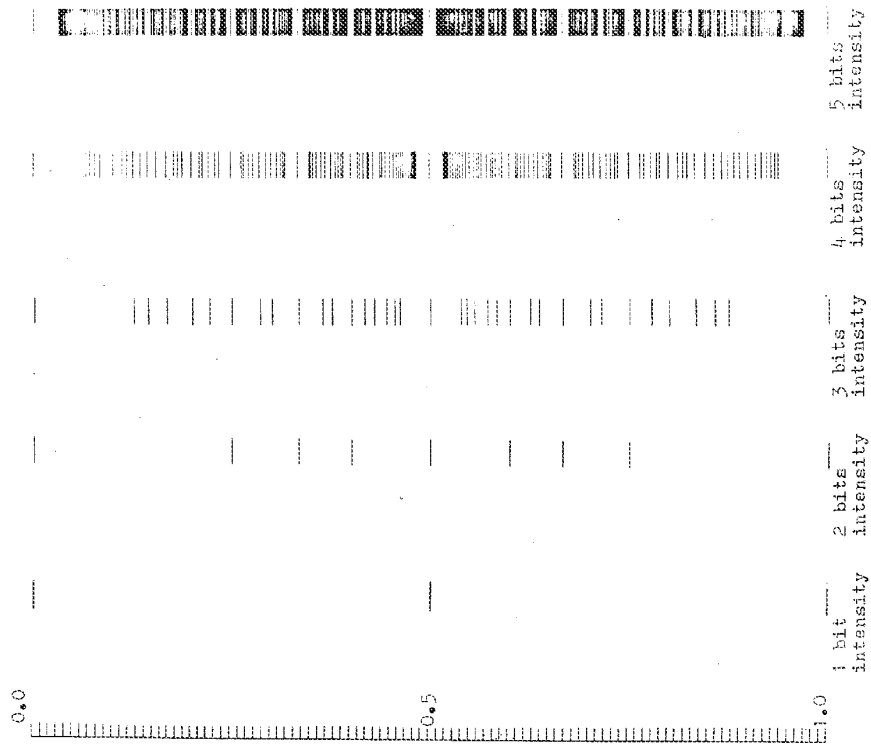

Fig. 4.5 Centers of pressure interpolated from two sensors with the number of available bits for pressure being 1, 2, 3, 4, and 5 from left to right.

Each line represents a possible interpolation point.

for possible combinations of the intensities from two adjacent sensors. However such an interpolation mapping scheme has not been implemented due to complications involved for more than two sensors.

However the interpolation should be performed in terms of the physical center of the touch shape. Since the intensity given by the capacitance measurement is dependent of the area of touch on the cover of sensor plate, the accurate center of a touch is more dependent of the size of the touch relative to the size of the sensor area as well as the shape of sensor plate.

For the implementation, however, it uses direct interpolation scheme for a few cases. One of interest is interpolating 3 by 3 sensors with a touched point in the center and the other is interpolation of all points on the tablet. The later one obviously gives highest resolution but it simply emulates a single touch tablet with a high resolution.

The software in the dedicated CPU utilizes the communication with the host computer to accommodate the interpolation scheme in the host computer.

4.7 SEQUENCE OF OPERATIONS

The programs in the dedicated processor are sequenced

as shown below. First, the tablet is initialized and a red LED on the tablet is turned on to indicate "DO NOT TOUCH". During this period, the reference values for all groups of sensors and the thresholds for each level are found. Automatic threshold settings, however, do not satisfy the user when the user wants to have less sensitivity on the level of touch. Therefore the threshold may be changed by the command from either the host computer or the terminal input. After the initialization, the CPU waits for further instructions from the input device. Whenever it is ready, the input device sets the operation modes through a sequence of instruction(s). The operations of each mode and commands are listed in appendix C.

```
--- Initialize
    - read reference values
    - obtain thresholds

--- Send ready signal
    - wait for further instructions

--- Set operation modes from input commands
    - set scan modes
    - set resolution (for only linear scanning
mode)
    - set communication mode
```

----- Scan and Report

In general, the program in the host computer would be application software that utilizes the FITSID. The sequence presented below would greatly vary with each application. However for each setting up the tablet for best performance according to the application is essential. The configuration of the system in the software is shown in Fig. 4.4.

In appendix C, the names of the routines and modes of operations in the dedicated CPU, as well as the communication protocols with the host computer, are detailed.

In order to run a program in the host computer, the local terminal inputs are directly transferred to the host computer which makes it possible to communicate between the user and the host computer.

- Signal to the local terminal that it is ready to receive data from the dedicated CPU.
- Wait for an acknowledgement.
- Setup output device.
- Setup the tablet according to the needs
- Read inputs from the dedicated CPU on the tablet.
- Process the data from the tablet.

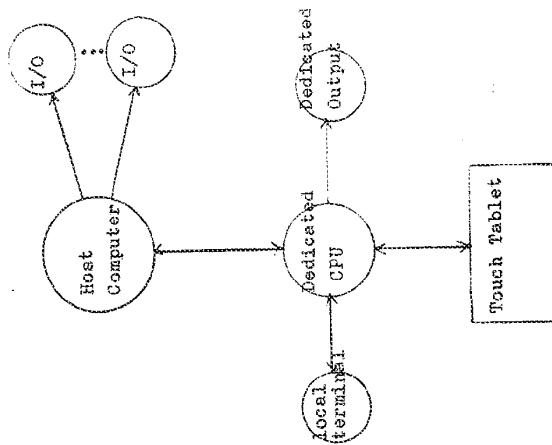

Fig. 4.4 System configuration.

----- Output to the designated device

4.8 CONCLUSION

In this chapter, software strategies and algorithms have been described. All scanning algorithms and commands have been implemented and tested. All software is fairly well documented for the user who wants to implement more features for his own application purposes. Testing results and some demonstration programs for a particular application are provided in the next chapter.

CHAPTER 5

PERFORMANCE TESTING

5.1 INTRODUCTION

This chapter presents the use of the FRTSID prototype as an integrated system, the characterization of the sensor matrix and various aspects of performance testing.

In section 5.2, the sensor matrix is evaluated in terms of its threshold values which are directly related to noise levels present. The times required to measure specific groups of sensors are identified by the reference values for each group. In section 5.3, the use of the prototype having an I/O terminal and a Unix port connected to the dedicated CPU is presented. Section 5.4 focuses on the spatial resolution and locatability of a fine resolution point obtained from interpolation of multi-finger touches. Section 5.5 deals with the test of response time delay under various conditions. In section 5.6, typical applications of the prototype are discussed and finally, section 5.7 summarizes various performance tests.

5.2 SENSOR MATRIX EVALUATION

An ideal sensor matrix for FMSID would be one that has uniform and small reference values over a grouping level, a large variation of intensity due to a touch and fast measurement time. The sensor matrix of the prototype, however, has a relatively wide range of reference values as shown in table 5.1. However these values, obtained in the normal laboratory environment, do not change very much over extended periods of time. The results show that a decrease of one column-grouping level increases the reference value by a factor of about 1.4. This corresponds well to the estimates made previously in chapter 3. As well the results show that a decrease of one row-grouping level, in contrast, does not increase the reference value in general, even if the number of the sensors is doubled in a group. These phenomena have been discussed in the previous chapter.

From the table, for the tablet left untouched, the capacitance discharge time can be derived directly: 1 count represents a 100 nano second interval.

The thresholds given in table 5.2 represent the stability, over time, for a specific grouping level. Using these threshold values, the CPU does not report untouched points wrongly over intervals of at least 3 hours in both linear and binary scanning modes. The binary scanning mode uses 6 different thresholds, consequently it is very unlikely to

report a wrong point whereas the linear scanning mode uses only a single threshold. Regardless of this, however, the tablet in linear scanning mode has remained for at least 3 hours before reporting a touch when in fact it has been left alone.

TABLE 5.2 TYPICAL THRESHOLDS FOR ALL GROUPING LEVELS

Level	0	1	2	3	4	5	6
Level 0	2	4	3	4	4	4	3
Level 1	2	3	4	5	6	4	3
Level 2	10	4	4	4	6	4	3
Level 3	7	4	5	4	6	4	3
Level 4	8	5	5	5	5	4	3
Level 5	6	5	5	6	6	6	4

The intensity of a single touch for a grouping level (5,6) varies over the tablet but usually ranges from the threshold value to 15. For the grouping level (0,0), it varies from person to person but it ranges from the threshold to 124. This maximum is obtained when a palm rather than a finger touches the tablet. Another interesting aspect of the grouping level (0,0) is that its scanning is very fast and as well allows detection of hands merely in the vicinity of the tablet.

In order to test the separation parameter as discussed

TABLE 5.1 REFERENCE VALUES FOR ALL GROUPING LEVELS

Column level	**0	1	*2	3	4	5	6
Row level	(a) 77	206	31	24	20	9	4
0	(b) 77.0	209.5	34.0	24.5	21.0	10.5	5.3
	(c) 77	213	36	25	23	12	6
1	(a) 16	120	5	133	22	10	4
	(b) 16.0	130.8	11.8	142.8	23.8	11.9	6.0
	(c) 16	144	29	163	26	14	7
2	(a) 69	171	53	205	49	22	6
	(b) 75.5	184.1	60.6	208.0	54.3	27.1	13.6
	(c) 81	199	75	214	59	42	25
3	(a) 108	196	75	238	123	60	29
	(b) 114.9	214.4	87.4	236.6	128.7	64.3	32.2
	(c) 124	230	104	247	137	70	36
4	(a) 113	208	88	242	142	71	34
	(b) 123.8	224.8	97.5	247.0	147.3	73.7	36.8
	(c) 132	241	113	254	154	77	40
5	(a) 116	209	91	245	149	74	36
	(b) 126.5	226.2	100.4	250.5	152.8	76.4	38.2
	(c) 137	241	116	250	159	80	41

(a) minimum value of the reference values in the grouping level
 (b) average value of the reference values in the grouping level
 (c) maximum value of the reference values in the grouping level

* single overflow; for actual count, add 256
 ** double overflow; for actual count, add 512

in chapter 3, a long and narrow metal plate was used to cover a number of sensors in a column. Using this test, the number of sensors covered by the metal plate that report touched sensors inaccurately (the separation parameter) varies from column to column, ranging from 11 to 28. The range of estimated separation parameter with various values of parameters was 6 to 25, discussed in chapter 3; a value reasonably within the actual measured range of variation.

The final test performed in characterizing the sensor was radio frequency interference sensitivity. Due to a lack of appropriate test equipment, a small transistor AM/FM radio was used. The radio had 9 volt battery and was set to medium volume with the antenna extended fully (about 18"). Noise from the radio resulted for almost all frequencies in the range 540 to 1600 KHz. It was observed that the radio makes a low constant noise when the tablet is scanning without touch and that a modulated sound results whenever the tablet is touched. However in comparison to the R.F noise produced when a key is entered on an I/O terminal (Lanparscope XT-100), the noise from the tablet when the tablet is touched, appears to be about 2 times greater. For this comparison, the distance between the device and the radio at which the noise disappears, was used.

5.3 USE OF THE PROTOTYPE

For development and test purposes, the environment in which the prototype operates, is shown in Fig. 4.4. With this configuration, three possible communication states to the 6809 have been considered, as shown in Fig 5.9. State A represents communication between the 6809 and a terminal. In this state most debugging commands are accessible and the CPU scans and reports the touched points to the terminal for all three scanning algorithms: linear scanning, modified linear scanning, and binary scanning. State B involves communication between the 6809 and the host computer. In this state binary scanning (with and without the interpolation mode) is available making it possible for the host computer to interpolate 3 by 3 subarrays around a touched point, as well as to interpolate all points for one complete scanning. Finally state C is simply a "wired" mode which transfers the inputs from the keyboard directly to the host computer so that the programs in the host computer can be executed simultaneously with the scanning program in the 6809 in state B.

Commands for each of the states and the data formats for communicating with the host computer are listed in appendix C.

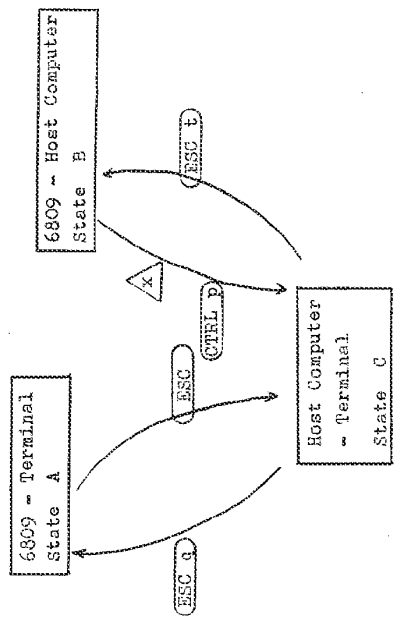

Fig. 5.0 The state diagram for communication modes
 - state change parameter from terminal
 - state change parameter from host computer

5.4 SPATIAL RESOLUTION

One of the benefits that may be obtained from a combination of the multiple sensing and intensity sensing characteristics is interpolation. Many interpolation schemes were considered and the results are discussed in this section.

One possible and immediate interpolation scheme is to interpolate a "touched" point with all adjacent values which may not be large enough to be reported as touched. A local array of 3 by 3 points is used for this interpolation. Some examples drawn on a laser printer using floating point input, are shown in Fig 5.1. These pictures are drawn without feedback, that is, drawn without the operator looking at the output screen. This does not allow the operator to select points where data are sparse in comparison with the intended figure but rather takes direct input from the location of the figure drawn on the input device. The first picture (a) is drawn by moving a finger in a straight line (guided by a ruler) for various angles and the second one (b) is drawn by moving a finger in a line guide by a circle drawn on a template. The third one (c) is picture drawn by putting a whole palm on the tablet. Note that the dots on a line do not have constant intervals and the "empty" location may be reduced by more tries for Fig. 5.1(a). In particular, the dots outside the shape of a palm, for fig. 5.1(c), are due to the separation parameter. The palm was pushed hard by

the other hand while the CPU scans the tablet. However, they would not be shown for soft touch by a palm.

Since the spatial resolution of the first scheme is limited by the number of bits available from the intensities of an array of 3 by 3 sensors, another scheme was considered. In this scheme, all the points from a complete scan of a tablet are interpolated allowing the potential resolution to be almost infinite. However this process simply emulates a projective device and accordingly reports only single point, which is interpolated from all the points on the tablet. However with this scheme, there could be many ways of pointing to a specific location on a display screen. To demonstrate this, the lines drawn by black dots on Fig 5.2(a) are obtained by moving a finger while a second finger is fixed at various points. The circle Fig 5.2(b) is drawn rather tediously, but with many combinations of finger points. Note, however, that it shows many points outside of the circle line. The pictures drawn by this scheme supposed to be much more accurate to the intended picture on the tablet. But it does not show on the pictures. This is because the operator could not see the output terminal. The locatability of a point on the tablet seen to be good however it should be measured in front of a display terminal for more accurate estimation.

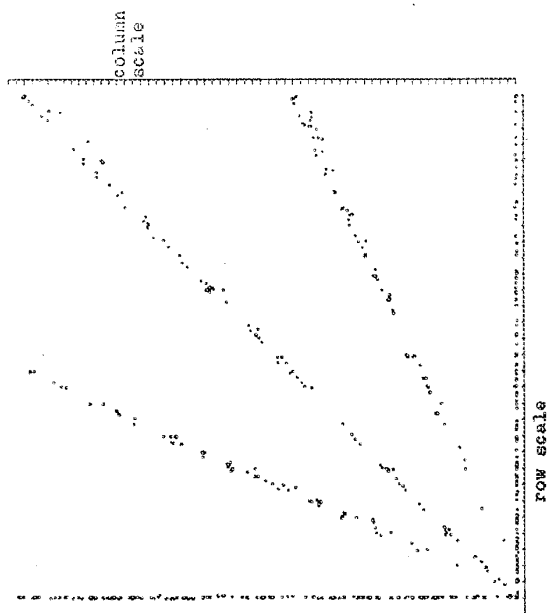

Fig. 5.1(a) Straight lines drawn by the tablet using 3 by 3 sensor array interpolation. The scales shown represent the boundaries of the actual sensors.

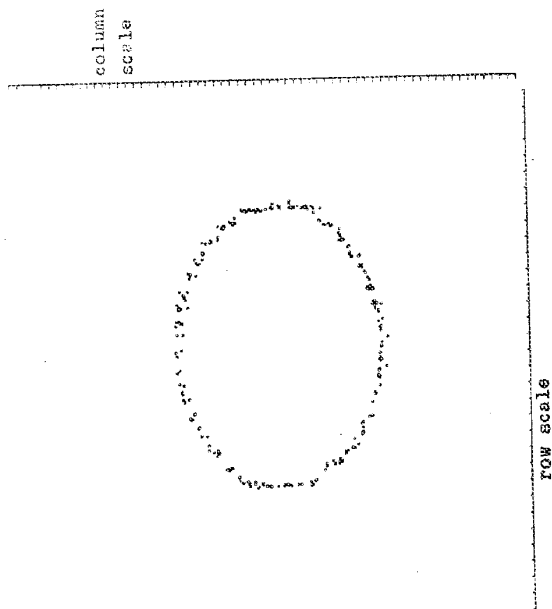

Fig. 5.1(b) A circle drawn by the tablet using 5 by 5 sensor array interpolation. The scales shown represent the boundaries of the actual sensors.

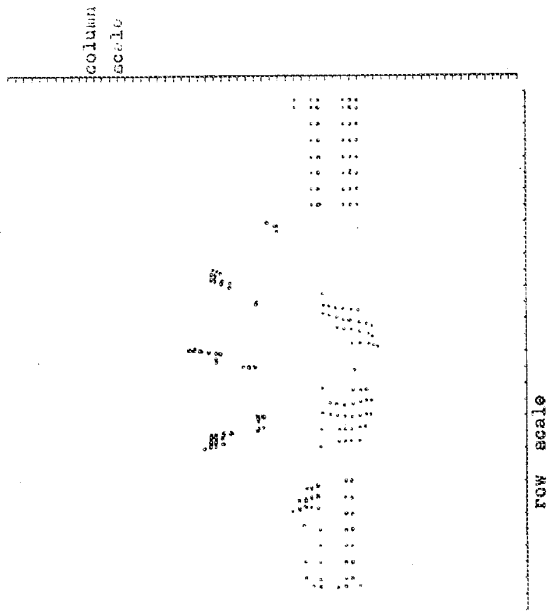

Fig. 5.1(c) A palm drawn by the tablet using 3 by 3 sensor array interpolation. The scales shown represent the boundaries of the actual sensors. The dots outside the "palm shapes" are due to inebility in distinguishing points in a column(separation parameter).

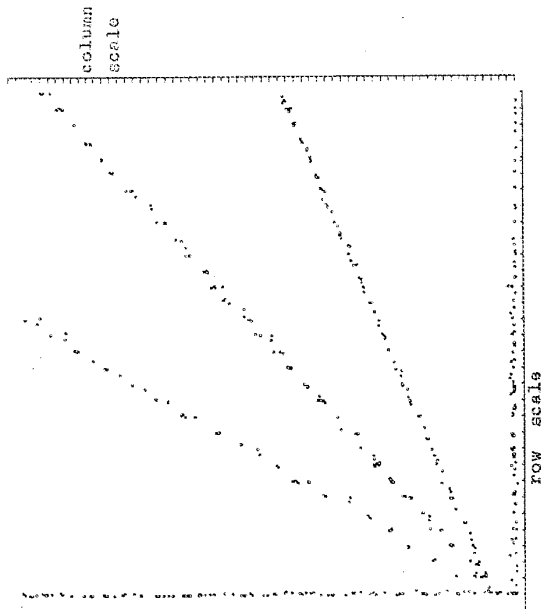

FIG. 5.2(a) Straight lines drawn by the tablet using interpolation of all touched points on the tablet at every scan. The scales shown represent the boundaries of the actual sensors.

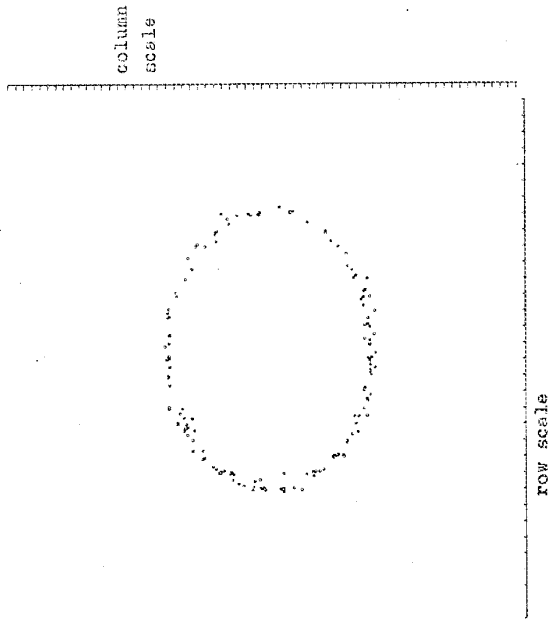

Fig. 5.2(b) A circle drawn by the tablet using interpolation of all touched points on the tablet at every scan. The scales shown represent the boundaries of the actual sensors.

5.5 RESPONSE TIME DELAY

The response time delay is the time delay from the beginning of a touch to an output to either a local terminal or an output device attached to the host computer. For multiple touches, this delay will increase with the number of touches. In general, the response time delay is composed of several different components.

For example, the single touch response time results from the combination of four interrelated processes.

Process I - Generation of bit patterns for row and column registers and reference address calculations from row and column addresses.

Process II - Capacitance measurement from resulting bit patterns.

Process III - Processing for the binary scanning.

Process IV - Processing for communication.

Note that some of these processes are intermixed with others. For example the binary scanning process itself uses capacitance measurement as well as bit pattern generation. However the time implied above for the binary scanning process is just the overhead assuming instant generation of the bit patterns and instant capacitance measurement. In practice each of the processes above can be distinguished

clearly and the response delay time for a single point can be derived from the time required for each.

Various cases are considered and tabulated in table 5.3. Actual response times were measured several times and averaged. These are compared with the results obtained by evaluating execution time of software routines and using the specifications for the communication speed of the terminal. They are tabulated in table 5.4. The results show that the calculations and the actual response time delays lie within a reasonable range, with the overhead due to the command and other uncounted processes ignored in the calculations. Figures are given to show the proportion of the time taken by each processing phase.

5.6 TYPICAL APPLICATIONS

The tablet can be applied to emulate virtually any kind of device that utilizes position input as well as intensity in some form. For example, with appropriate templates, it is possible to emulate a Qwerty keyboard, a piano keyboard, a percussive device (with low resolution), a cursor positioning device such as a joystick or a mouse, a graphics tablet, or a finger pointing input device [ref 5.1]. Above all, it is possible for the FMSID to form a collection of virtual devices from which input is available

TABLE 5.3 APPROXIMATE TIMES REQUIRED FOR
PROCESSING THE SOFTWARE

PROCESS	BEST CASE	WORST CASE
I	2.3 msec	7.0 msec
II	8.9 msec	28.9 msec
III	1.0 msec	3.4 msec
IV	9.3 msec	10.5 msec
TOTAL	21.4 msec	49.8 msec

- I - Time required for bit pattern generation and reference address calculations in searching for a point with binary scanning.
- II - Time taken in reading the sensor capacitance in searching for a point with binary scanning
- III - Binary scanning overhead, generation of row and column addresses and calling all of above routines.
- IV - Communication overhead for a 9600 baud rate assuming 10 bits per transmission for a single character. There are 9 bytes of data for a coordinate.

TABLE 5.4 ACTUAL RESPONSE TIMES

Case	best	typical	worst
(a) pts/sec	17.6	15.2	12.8
msec/pt	56.8	65.8	78.1
(b) pts/sec	19.2	17.2	16.0
msec/pt	52.1	58.1	62.5
(c) pts/sec	24.0	22.0	18.8
msec/pt	41.6	45.5	53.2

- (a) measured by one sensor touched continuously
- (b) measured by two sensors touched at the same time continuously
- (c) measured by four sensors touched at the same time continuously
- Note all values obtained were based on communication between the 6809 and Lanparscope XT-100 terminal using the jump scroll mode.
- pts/sec = points per second
- msec/pt = milliseconds per point response

simultaneously.

5.7 CONCLUSION

This chapter has included the results of most tests that could be done in a normal laboratory environment. Importantly it has emphasized testing for the "new" sensor with a binary scanning algorithm. It seems, in general, that the new sensor performs better than expected from calculations and simulations. This is because of the unaccounted fact of column capacitance coupling. However some unexpected results were found such as the inability to sense touchiness for three grouping levels (3,0), (4,0) and (4,1). Also noted were strange variations of the reference values in the row grouping levels 0, and 1. These effects likely result from unmatched diodes and other components. More detailed analysis is left for those who are to develop the sensor matrix in VLSI as discussed in the next chapter.

CHAPTER 6

CONCLUSIONS

6.1 INTRODUCTION

A prototype of a fast-scanning multiple-touch-sensitive input tablet having both the adaptability and flexibility for diverse applications has been designed and implemented. Capacitance measurement of individual sensor(s) which can be uniquely addressed using two diodes per sensor, makes it possible to sense both the positions and intensities of one or more simultaneous touches without ambiguity. The sensor matrix is controlled by University of Toronto 6809 board whose serial port is connected to one of the I/O ports of a host computer. Software that utilizes binary scanning for fast scanning an array of 64 by 32 sensors on the tablet, and that communicates with the host computer, has been implemented and tested.

The prototype has, however, still room for improvement in many areas. Section 6.2 focuses on the possibilities for hardware and software enhancement. In section 6.3, the problems of the sensor matrix are discussed and, finally, section 6.4, concludes with directions for future research

on the FMSID.

6.2 ENHANCEMENT POSSIBILITIES

Even though the prototype has proved that the binary scanning algorithm with suitable hardware solves the problem of speed limitation inherent in measurement of sensor capacitances with linear scanning, some musical input applications, such as to percussive instruments for example, require greater speed with more parameters. At present the tablet operating at the zero grouping level is quite fast, however only a 3 value is available.

The speed may be improved by both hardware and software enhancements indicated to reduce two major time delays in the response time measurement. These are in the software for the binary scanning process and in communication between the host computer and the device.

A possible enhancement of the software may be derived from the fact that some instruments can be emulated with a particular speed requirement as well as with a particular sensor grouping configuration. In such a case, data structures for reference and bit patterns in the row and column registers could be made specific to the particular application. Thus blocks of sensors can be predefined by software before the application, thereby greatly reducing the

scanning possibilities. Accordingly the author believes that a dynamic data structure with scanning zones on the tablet, which are variable according to the emulation of particular device(s), may increase the response speed considerably.

Hardware enhancements, on the other hand, that increase the speed of the scanning process, should incorporate both parallel communication and possibly a bit slice programmable processor for the scanning process itself. The ultimate response time delay reduction may be obtained not only by reducing the amount of data that communicates between the host and local processors by allowing more processing at the dedicated processor, but also by parallel communication with the host computer. The other possibility is that of putting the capacitance measurement time whose maximum is about 70 microseconds, the bit pattern generation and reference addressing, into a pipeline. This could reduce the time for scanning the tablet completely for the number of finger touches limited to 10, to less than 7.5 milliseconds assuming that longest delay path in the pipeline is the time required to discharge the sensor capacitance. However each of these changes should be considered with a specific application in mind.

6.3 SENSOR MATRIX ENHANCEMENT

There are many problems in the constructed sensor matrix compared to an "ideal sensor". Some are compensated by the software but the others remained unresolved. As discussed in section 2.2 and in section 5.2, the following problems with the sensor matrix remain.

- 1. Each sensor is not perfectly matched due to unmatched diodes, mismatch of circuits attached to the column and row, location differences over the tablet and size variation in the unit sensor plate.
- 2. The threshold for detection of touchedness is dominated by a need for noise elimination rather than "thresholding" a degree of touchedness. This noise originates in the offset voltage of the comparator as well as in instability in discharging currents.
- 3. There are simply too many components to assemble in constructing the sensor matrix; by conventional means, for example there are about 4 thousand diodes to connect (64*32*2).
- 4. The hardware resolution is only 64 by 32 for a 12" by 16" tablet.

Since the diode array on the tablet is uniform, it seems that for large quantity production, a wave soldering technique with automatic insertion equipment[ref 6.1] and small customized diode network chips may be feasible. Some aspects of the first problem and the third problem may be solved by this technique. The second problem may be reduced by a more careful and closer examination of the sensor matrix. The hardware resolution may be increased by a choice of higher dielectric constant separators with smaller sensor area and by increasing the counting clock frequency and using a more stable discharging current.

Current research on flat TV systems in some countries utilizes many techniques for assembly of active components on a large area, as large as a TV screen[ref 6.2]. It shows some interesting results related to the same problem of mounting active components on a large surface area. If the same technology is applied to the assembly of the sensor matrix, it seems possible that the majority of the problems above could be solved. Thus it is likely that the ultimate PRTSID will utilize techniques to be developed by the large flat screen TV system development in the near future.

6.4 FUTURE RESEARCH

Future research should be directed in accordance with the previous discussion on future enhancements. The author believes that the "final form" of PMSID should be as a stand-alone device using a transparent touch plate such as indium tin oxide [ref 5.2]. Such a panel could be put on the top of the display system as is done with current touch screen devices. By this means feedback could be obtained directly under the finger tip. As well of course, tablet templates could be directly and dynamically shown to the user. Such developments, however, must follow more complete research on the use of Thin Film Technology for flat TV screen display systems.

REFERENCES

- [ref1.1] "A Touch Sensitive Tablet as Extensible Device" by W.Buxton, G.Fedorkow, L.Sasaki, and K.C.Smith, Computer Systems Research Group, 1983
- [ref1.2] "A Touch-Sensitive Input Device", Proceedings of the Fifth International Conference on Computer Music, North Texas State University, Denton, Texas, November, 1981.
- [ref2.0] "Why Touch Sensing" by Louise C.Shaw, Datamation, August 1980, p138-p141
- [ref2.1] United State Patent 3,790,370 March 19,1974, Electrographic Sensor for Determining Planar Coordinates and 3,911,215 October, 7, 1975, Discriminating Contact Sensor by George S. Hurst, Elographics, Incorporated,
- [ref2.3] "New Touch Screen Computer" by George Mitchell, Computers and Electronics, December,1983, p57 - p66

- {ref2.4} Touch Screen Digitizer Data Sheet from TSD
Display Product Inc., 1982
- {ref2.5} A Flexible Human Machine Interface, M.A.Sc.
Thesis, University of Toronto, 1982 by Himish
Metha
- {ref2.6} TASA Model: x-y 3600 and x-y controller, Model:
FR-105 Data Sheet 1980
- {ref2.7} Pressure-Sensitive Conductive Rubber Data Sheet
by JSR PCR 1981
- {ref2.8} A circuit diagram drawn by Fedorkow in March,
1981, University of Toronto
- {ref3.1} "Curing Static Electricity" by Elliott
S.Kanter, Radio Electronics, Sept., 1984
- {ref5.1} Manipulating Simulated Objects with Real-world
Gestures using a Force and Position Sensitive
Screen by Margaret R.Minsky, Computer Graphics
Volume 18, Number 3 July 1984
- {ref6.1} Solders and Soldering by Howard H. Hanks,
McGraw-Hill, 1979, p252 - p257

R-2

[refs.3] "Liquid Crystals Big, Bright, even Colourful
Displays" by Gordon Craff. High Technology
mag/1984 p55 -p68

R-3

APPENDIX A

ANALYSIS ON SENSORS IN ONE COLUMN

In this appendix, sensors in one column are analyzed in terms of the instantaneous voltage during the discharge period, the ratio of sensor capacitance to the surrounding capacitance, and separation parameters. All these parameters are derived from the characteristics of the discharging voltage on the column line.

Two assumptions are made in modelling the diodes:

1. The resistance of a forward biased diode is very small compared to the timing resistor R.
2. The resistance of a reverse biased diode is very large compared to the timing resistor R.

These assumptions simplify the derivation of the equations for all parameters. For these, the diode model is as follows:

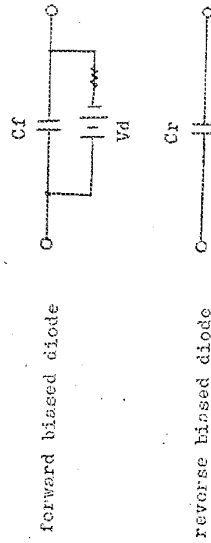

This model is used for all derivations. As well, the following assumptions are made:

1. All diodes are matched.
2. All sensor plate capacitances (C_s) are identical and have a value of zero when the plate is not touched.
3. Each column is electrically separated from all others.

Amongst many possible cases for the analysis of the sensor array, two will be considered here. The instantaneous voltage during the discharge period and the discharge time constant are obtained for both cases. As well, from this analysis separation parameters are obtained for various parameter changes.

Case A: A selected sensor is touched, while the remaining sensors in the column are not touched.

Charging period: The selected row line is connected to V_{cc} .

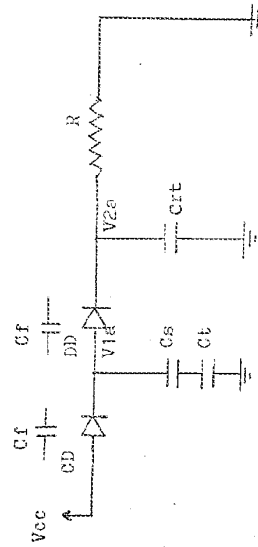

A-2

CD, DD are the charging and discharging diodes respectively.

Crt is the total capacitance of the reverse biased diodes in the column connected to untouched sensors.

Ct is the capacitance associated with the touching finger, and considered here to be 100pf.

function:

--- CD and DD are charged with $Qf = Cf * Vd$.

--- $Cs || Ct$ is charged with $Qs = Cs || Ct (Vcc - Vd)$.

--- Crt is charged with $Qrt = Crt (Vcc - 2Vd)$.

Discharging period: The selected row line is grounded.

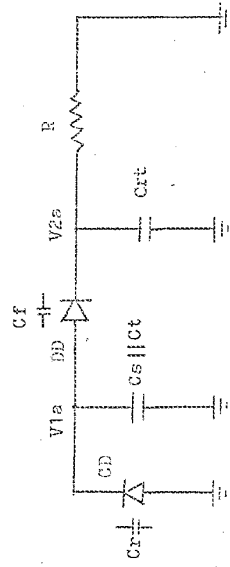

function:

1. CD is discharged by Qf and charged by Qr = Cr * V1a. The charges Qf and Qr come from Cs, and from Crt through DD. Consequently DD is reverse biased, releasing Qf in DD and accumulating a charge Cr * (V2a - V1a).

2. For some time later, DD is forward biased. However, if the time interval is very small, not much charge is lost through the timing resistor R and consequently V2a can be easily estimated. This assumption is verified by an experiment using Crt = 68pF, R=100k, Cs=9.4pF and two diodes. The measured time was less than 100 nano-seconds.

The instantaneous voltage V2a for case A can be found as follows.

$$V2a = \frac{Qs + Qr - Qf - Qr}{Cr + Cs + Crt}$$

$$= \frac{Cs \parallel [Ct * (Vcc - Vd) + 0.5 * (n-1) * Cr * (V - 2 * Vd)] - Cf * Vd - Cr * V2a}{Cr + Cs + Ct + 0.5 * (n-1) * Cr}$$

$$V2a = \frac{s * (Vcc - Vd) + 0.5 * (n-1) * (Vcc - 2 * Vd) - f * Vd}{s + 0.5 * (n+3)}$$

where s = Cs || Ct / Cr and f = Cf / Cr.

The time constant for case A, Ta is:

$$Ta = [Cs + Cr + 0.5 * (n-1) * Cr] * R$$

The discharging voltage (V_a) is:

$$V_a = V_{2a} \exp\left(-\frac{t}{T_a}\right) \text{ ----- equation (1)}$$

Case B: Several m non-selected sensors are touched simultaneously.

Charging period: A selected row line is connected to V_{cc} .

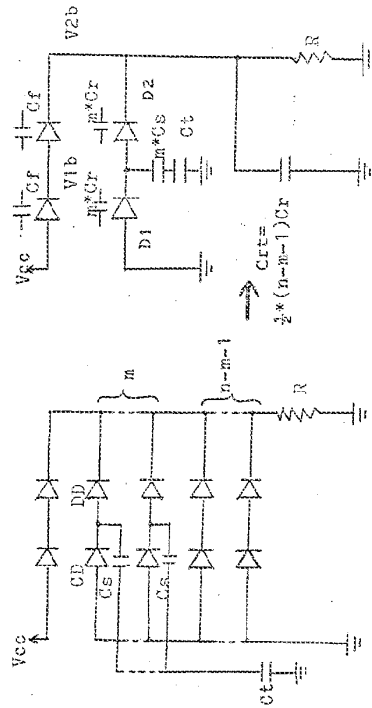

C_m is the total capacitance of m touched sensor plates with diodes as shown above.

C_{rt} is the total capacitance of reverse biased non-selected, and non-touched diodes.

function:

CD and DD are charged by $QF = Vd * Cf$.

D1 and D2 represent m multiple reverse biased diodes which are charged by $Qm = Cm*(Vcc - 2*vd)$.

Crt is charged by $Crt*(Vcc - 2*vd)$.

Cm is given as follows.

$$Cm = \frac{m*Cr*(m*Cr+m*Cs||Ct)}{m*Cr+m*Cs||Ct}$$

$$\frac{m*(m*s+t)+m*s*t}{2*m*s+2*t+s*t} * Cr$$

where $s = Cs/Cr$, $t = Ct/Cr$ and m is the number of touches.

$$Crt = 0.5*(n-m-1)*Cr.$$

Discharging period: A selected row line is grounded.

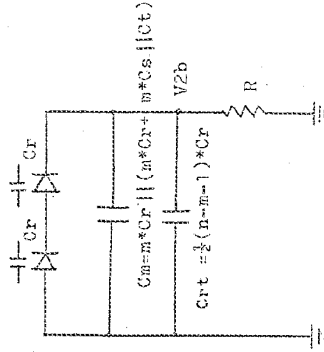

The instantaneous voltage V_{2b} for this case is:

$$V_{2b} = \frac{Q_m + Q_{it} - Q_f}{Q_m + Q_{it}} \cdot \frac{Q_m + C_{it}}{C_m + C_{it} + 0.5 \cdot C_f} (V_{cc} - 2 \cdot V_{Df})$$

The time constant for case B, T_b is :

$$T_b = (C_m + C_{it} + 0.5 \cdot C_f) \cdot R$$

The discharging voltage for case B, V_b is:

$$V_b = V_{2b} \cdot \exp\left(-\frac{t}{T_b}\right) \text{ ----- equation (2)}$$

Calculation of the separation parameter

From equation 1, the time (T_{th}) taken for V_f to reach the threshold voltage V_t is given by

$$T_{th} = T_a \cdot \ln\left(\frac{V_{2a}}{V_t}\right)$$

and from the equation 2, the time taken for V_b to reach the threshold voltage V_t is given by

$$T_{tb} = T_b \cdot \ln\left(\frac{V_{2b}}{V_t}\right)$$

Equating the two to solve for m , the separation parameter,

$$T_a \cdot \ln\left(\frac{V_{2a}}{V_t}\right) = T_b \cdot \ln\left(\frac{V_{2b}}{V_t}\right)$$

Using this equation, m can be estimated for various parame-

ter changes. The results are listed below.

TABLE A SEPARATION PARAMETERS

$f=Cf/Cr$	$s=Cs/Cr$	$t=Ct/Cr$	m
12.5	2.5	25.0	8
25	5	25.0	25
12.5	5	25.0	25
25	2.5	25.0	8

s	case 1	case 2	case 3
2.0	6	5	6
2.2	7	7	6
2.4	8	7	7
2.6	9	8	8
2.8	10	9	9
3.0	11	10	10
3.2	12	11	11
3.4	14	12	12
3.6	15	14	13
3.8	17	15	14

case 1: the value of m for $f=12.5$ and $t=20.0$
 case 2: the value of m for $f=12.5$ and $t=25.0$
 case 3: the value of m for $f=12.5$ and $t=30.0$

APPENDIX B

SUBTRACTION OF OVERFLOWED 8-BIT COUNTER VALUES

This appendix classifies all possible results of subtraction of 8-bit data which are residues of modulus 256. The purpose of this analysis is to demonstrate that when the difference of two data words whose number of bits may be larger than 8, is not greater than 127, it may not be necessary to consider all the bits in the data words. Accordingly in the comparison of the two data residues, only the least significant 8-bits in a word are used and all the other bits are ignored.

Consider the operation $A - B$. There are 8 cases to consider. Our interest is to find the condition bit settings for an operation on the least significant 8 bits, and compare it with a full word operation.

the case for which $A < B$ using full word comparison

case (example)	condition bits
A+ (\$126) B+ (\$128)	S
A+ (\$307) B- (\$381)	S
A- (\$0B9) B- (\$0F3)	S O
A- (\$2F3) B+ (\$317)	S O

S - sign bit is set
O - overflow condition bit is set

the case for which A > B using full word comparison

```
-----  
cases (example)      condition bits  
-----  
A+ ($369) E+ ($324)  
A+ ($322) B- ($2B3)      0  
A- ($304) B- ($3C9)      0  
A- ($3C7) B+ ($37C)      0  
-----
```

The signs on the letters A and B represent the most significant bit(8-th). If -, then the bit is one, and if + then the bit is zero. The case A- < B+ implies that B+ has undergone one more overflow than A-.

The results show that A > B if the sign is not set, and that A <= B if the sign and zero condition bits are set regardless the condition of the overflow condition bit. This implies that the branch instruction BLE, BGE, BLT, or BGT cannot be used since they all use the overflow condition bit.

APPENDIX C

SUBROUTINES, COMMANDS, AND DATA FORMATS

In this appendix, major subroutines implemented in the dedicated CPU, commands in both local and host modes, and protocols for the communication between the 6809 and the host computer are briefly described.

Subroutines:

NAME: main

FUNCTION: Main routine - initializes the tablet and puts it into local mode.

PARAMETER: none

CALLED BY: the 6809 monitor program.

NAME: wire

FUNCTION: To transfer terminal input data directly to the host computer.

PARAMETER: none

CALLED BY: main, host; the command in main is w and the command in host is ESC t

NAME: host

FUNCTION: Communicates with the host computer. All commands are received from the host computer.

PARAMETER: none

CALLED BY: Wire mode by a command from the terminal input
ESC t.

NAME: bs -- binary scan

FUNCTION: Scans the tablet using the binary scanning algorithm.

PARAMETER: Output routine location; rowaddress, columnaddress, pressure are set before issuing jsr to the output routine.

CALLED BY: main, host

NAME: ls -- linear scanning

FUNCTION: Scans the tablet sequentially (linearly).

PARAMETER: Output routine location; rowaddress, columnaddress, pressure are set before issuing jsr to the output routine.

CALLED BY: main

NAME: ms -- modified linear scanning

FUNCTION: Scans the tablet using modified linear algorithm (scans row first and then columns if the row is touched)

PARAMETER: Output routine location: rowaddress, columnaddress, and pressure are set before issuing jsr to the output routine.

CALLED BY: main

NAME: stream

FUNCTION: Sends data in stream mode (sends data as long as the tablet is touched)

PARAMETER: none

CALLED BY: host

NAME: gettemp - get template

FUNCTION: Gets the codes on a template if there is a template on the top of tablet.

PARAMETER: none

CALLED BY: main, host

C-3

NAME: intp - interpolation

FUNCTION: Sends rowaddress, columnaddress and a 3 by 3 of pressures for interpolation of touch points.

PARAMETER: none

CALLED BY: main, host

NAME: init - initialization

FUNCTION: Initializes the tablet: sets up the reference values and threshold values

PARAMETER none

CALLED BY: main, host

NAME: average

FUNCTION: Averages 4 pressure values.

PARAMETER: ctout(counter output)

CALLED BY: bs, ls, ms

NAME: readp

FUNCTION: Reads the pressure of a group of sensors

PARAMETER: rowvec(the row vector that is, the bit pattern for the row selection registers), colvec(the

column vector that is, the bit pattern for the
column switch selection register)

CALLED BY: bs, ls ,ms

Commands in local mode

- t -- shows threshold values for all grouping levels
- r -- shows reference values for a grouping level
- l -- linear scanning
- b -- binary scanning
- m -- modified linear scanning
- a -- manual threshold input
- c -- change the grouping level for the linear scanning mode
- i -- initialize the tablet (set up the reference and threshold values)
- n -- set a set of new thresholds

Commands for the host computer

- g -- go; input from the 6809 (tablet ready signal),
- the host can send a command upon receiving g

i - initialization; output to the 6809
 - initialize the tablet; gets new thresholds and
 reference values
 n - set new thresholds; output to 6809
 w - send the thresholds for all levels
 r - send the reference values to the host
 d - delta mode (send data only if there is a delta
 change)
 - send a pixel only if there is a change
 (not implemented)
 s - send the data in stream mode
 t - send the pattern of the template lying on the top
 of the tablet
 x - go back to wire mode so that terminal can talk
 directly to the host

Data formats

s scan mode: stream mode
 r pixel pixelf r pixel
 where pixel = xnyzz
 — xx, yy, and zz are row, column, and pressure in hexade-
 cimal ascii values.
 p scan mode: interpolation mode

```
r ipixel ipixel ... if r ipixel .....
where ipixel = xxxxxxxxxxxxxxxxxxxx
```

— the position of the adjacent pixels is (-1,-1)(0,-1)(1,-1)(1,0)(1,1)(-1,0)(-1,1)

w mode: threshold values for all levels

```
(t(i,j),i=0,7),j=0,6)
```

where i is the column level, j is the row level and t is an array of two byte hexadecimal.

t mode: template pattern

```
r pixel pixel ... if
```

where the sequence of pixels is the template pattern.

r mode: reference data format

— specify the sensor grouping level(rl, cl) to the 6809
(z(coladr,rowadr),coladr = 0, lca), rowadr = 0,
lra)<CR>?

where lca = 1 << cl - 1 and lra = 1 << rl - 1.

General communication protocol

C-7

W. Daniel Hillis

Artificial Intelligence Laboratory
Massachusetts Institute of Technology
Cambridge, MA 02139

A High-Resolution Imaging Touch Sensor

Abstract

A dexterous robot manipulator must be able to feel what it is doing. The mechanical hand of the future will be able to roll a screw between its fingers and sense, by touch, which end is which. This paper describes a step toward such a manipulator, an imaging tactile sensor with hundreds of pressure sensors in a space the size of a fingertip. The sensor was designed as part of a tendon-actuated mechanical finger, similar in size and range of motion to a human index finger (Hillis 1981). As a demonstration, the device was programmed to distinguish among several commonly used fastening devices—nuts, bolts, flat washers, lock washers, dowel pins, cotter pins, and set screws—by touching them with the finger and analyzing the tactile image.

This paper describes how the tactile sensor array was constructed and how it works. The simple pattern-recognition techniques used in the demonstration program are also outlined. The final section notes some promising directions for future research.

The Sensor

The touch sensor is a monolithic array of 256 tactile sensors that fits (appropriately) on the tip of a finger. This resolution is comparable to that of the human forefinger. Each sensor has an area of $<0.01 \text{ cm}^2$ and gives an independent analog indication of the

force over its surface over a range of 1–100 g. The array is scanned one column at a time to minimize the number of connecting wires. The sensor is rugged, flexible, and has a skinlike texture.

The touch array has two conductive components: a flexible, printed circuit board and a sheet of anisotropically conductive silicone rubber (ACS). The ACS has the peculiar property of being electrically conductive along only one axis in the plane of the sheet. The printed circuit board is etched into fine parallel lines, so it too conducts in only one dimension. The two components are placed into contact with the lines on the printed circuit board perpendicular to the ACS axis of conduction. The contact points at each intersection of the perpendicular conductors form the pressure sensors.

The device also includes a separator to pull the conducting layers apart when pressure is released. The sensitivity and range of the sensor depend largely on the construction of this intervening layer. There is a trade-off between sensitivity and range. For a large pressure range, the best separator tested was the woven mesh of a nylon stocking. For high sensitivity, a separator may be deposited directly onto ACS by spraying it with a fine mist of nonconductive paint. The conductive rubber presses through the separator so that the area of contact, and hence the contact resistance, varies with the applied pressure.

The pressure/resistance relationship is nonlinear, as shown in Fig. 5. We do not have a model of the contact mechanism that quantitatively explains the change in resistance with applied pressure; however, Fig. 1 illustrates a plausible qualitative model. Pressure on the elastomeric ACS deforms the material around the separator, allowing it to contact the metal below. Larger pressures result in more deformation and larger contact areas. If the resistance of the contact is proportional to the contact area, the contact resistance will be inversely related to the applied pressure. For the object-recognition application, the nonlinear response of the sensor was not a significant drawback.

This report describes research done at the Artificial Intelligence Laboratory at the Massachusetts Institute of Technology. The research was supported in part by IBM, under an agreement with the Massachusetts Institute of Technology Laboratory for Computer Science. Support for the Artificial Intelligence Laboratory's artificial intelligence research is provided in part by the Advanced Research Projects Agency of the Department of Defense under contract with the Office of Naval Research, contract N00014-80-C-0505. The author is supported by a fellowship provided by the Fannie and John Hertz Foundation.

The International Journal of Robotics
Research, Vol. 1, No. 2, Summer 1982,
0278-3649/82/020033-12 \$05.00/00
© 1982 Massachusetts Institute of Technology.

Fig. 1. Contact resistance changes with changing area.

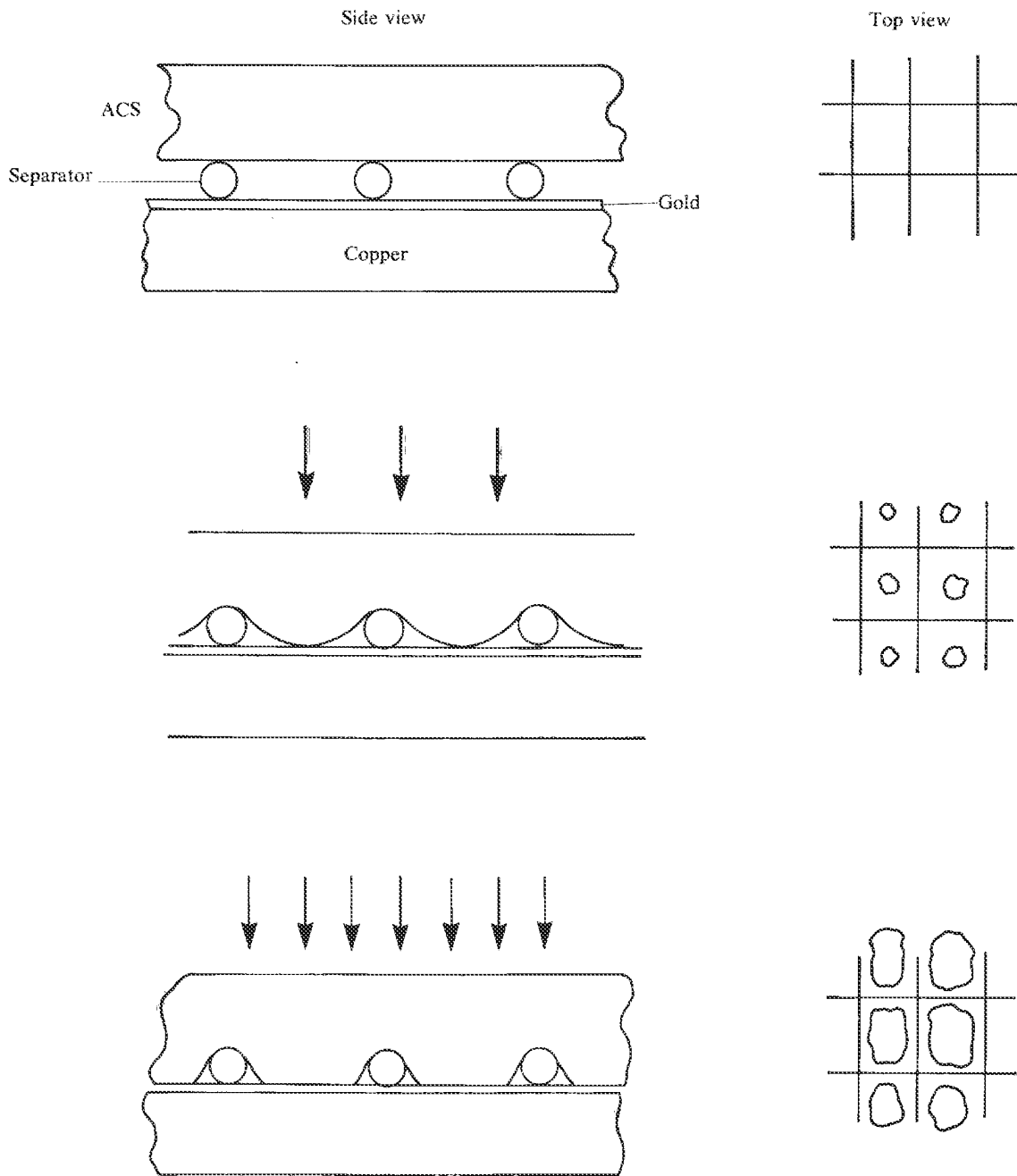

Fig. 2. Mechanical drawing of touch sensor. ACS = anisotropically conductive silicone rubber; PC = printed circuit board.

The ACS itself is constructed of layers of silicone rubber impregnated with either graphite or silver, alternating with similar nonconductive layers. Each layer is approximately $250\ \mu$ thick. The layers are oriented at right angles to the plane of the sheet. The linear resistivity, in the conducting direction, is on the order of kilohms per centimeter for graphite-impregnated ACS. This is inconveniently high for building large sensors, and we were able to lower it to approximately $100\ \Omega$ per centimeter by electroplating the sheet with gold. It is possible to plate only over the conductive silicone, so that the cross-resistance remains essentially infinite. Silver-impregnated silicone rubber has a substantially lower bulk resistance, but we were unable to obtain the material in the proper form. The minimum resolution of commercially available ACS is about 50 lines per centimeter.

Wires are soldered to the edges of the printed circuit board. The ACS is mounted so that its edges fold around the printed circuit, where they are pressed against contact fingers on the other side (see Fig. 2). A compound sensor with high range and good sensitivity may be constructed by placing a high-range (nylon mesh) sensor behind a sensitive one. In this case, the flexible circuit board in the front layer was eliminated, so that the center layer of ACS was shared between the two arrays.

Scanning the Array

Attaching wires only at the edges of the array reduces the number of necessary connections. This is important given the limited space of a mechanical finger. (The 256-cell sensor used 32 wires, #42, stranded. The resulting cable is $<3\ \text{mm}$ in diameter.) The array is scanned by applying a voltage to one column at a time and measuring the current flowing in each row. A potential problem with this method is the introduction of "phantom" tactile images. When multiple points are activated simultaneously, it may appear that untouched points are also conducting. This is the analog version of the crosspoint problem in xy -scanned keyboards: if three out of four switches on a rectangle are closed, the fourth appears to be also. This happens because the path

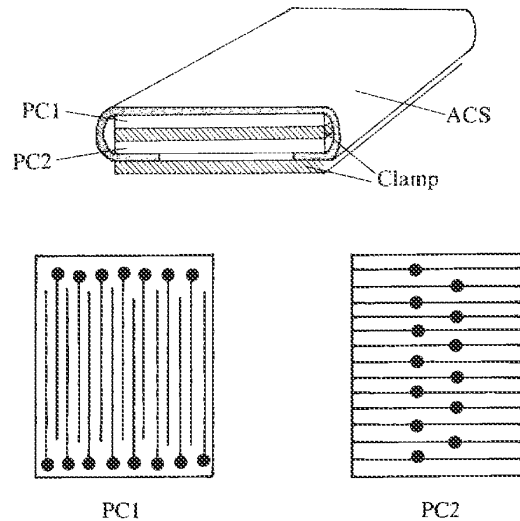

through the other three connections is electrically in parallel with the phantom connection. In keyboards, it is usually avoided by putting a diode at each point of intersection. This could be done for touch array also, but it would add considerably to the complexity of the device and it might also introduce undesirable mechanical stiffness. With resistive contacts, it is theoretically possible to compute the actual resistances from the measured resistances by solving N equations in N unknowns (Larcombe 1976), but the technique tends to amplify errors due to inaccuracy of measurement, noise, and resistance along the conductive axis. Other researchers (Stojiljkovic and Clot 1977; Broit 1979; Harmon 1982) have avoided the problem by attaching a separate wire to each sense point. This is impractical for high-resolution arrays and, again, it limits mechanical flexibility.

Instead, we used the scheme illustrated in Fig. 3. It is similar to the voltage-mirror approach suggested by Purbrick (1981). A fixed voltage is placed on the column of interest, while all other columns are held at ground potential to ground out any alternate paths. The rows are all held to ground potential also, by injecting whatever current is necessary to cancel the current injected by the active column. The value of the resistance of a crosspoint is inversely propor-

Fig. 3. Scanning the array.

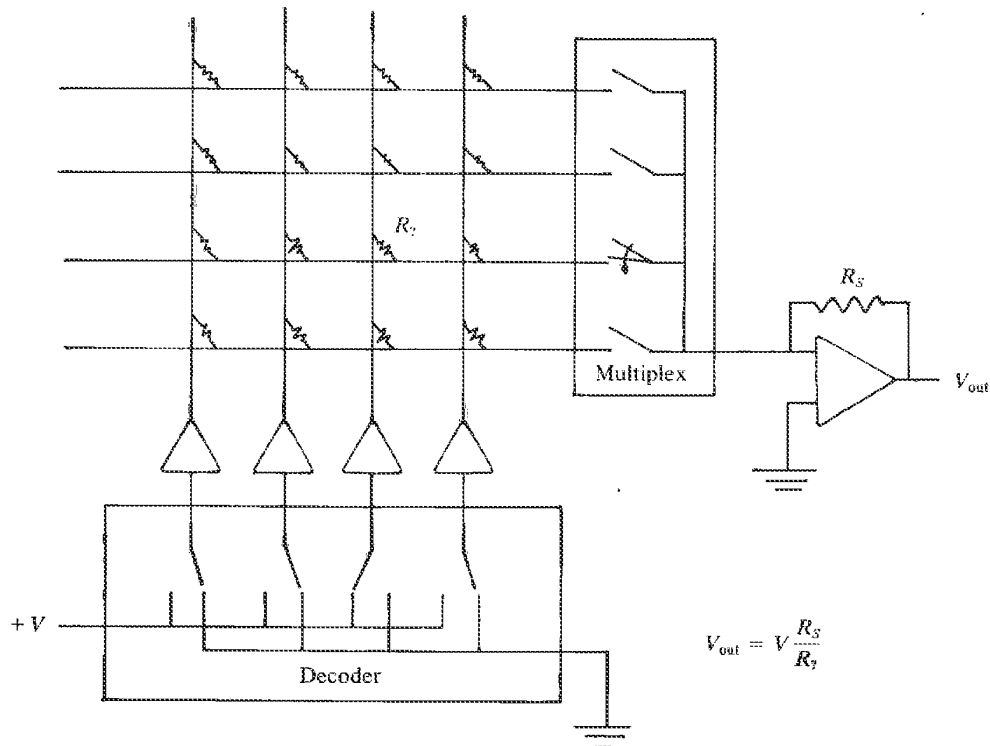

tional to the current that is necessary to pull the corresponding row to ground potential. By this method, extraneous columns are at the same potential as the rows (ground), so no current will flow through the unmeasured crosspoints. The holding currents depend only on the column drive voltages and the resistances in question. The entire array is scanned by measuring one column at a time, as described above.

The method described is valid only if the crosspoint resistances are high compared to the linear resistances of the row and column lines. Otherwise, it is not possible to hold an entire row or column at a fixed potential. This effect may be understood by referring to the electrical model of a single row illustrated in Fig. 4. The applied voltage (V) and the linear resistance (R_L) are known, but the unknown resistance (R_{C_n}) cannot be determined unless the potential at node N_n is known. This potential may be computed, in time proportional to the number of

nodes, by first measuring the unknown resistances near the edge. The resistance of all the the unknown contacts may be determined by computing the successive two-port parameters of the subnetworks toward the edge of the unknown node.

$$\begin{aligned}
 Z_0 &= 0 \\
 G_0 &= 1 \\
 R_n &= \frac{V - I_{mn}G_{n-1}(Z_{n-1} + R_L)}{I_n} \\
 Z_n &= \frac{R_n(Z_{n-1} + R_L)}{Z_{n-1} + R_n + R_L}
 \end{aligned}$$

where V is the applied voltage, I_n and I_{mn} the measured currents, Z_n the input impedance, and G_n the voltage transfer ratio of the network to the left of R_n .

For large arrays it may actually be necessary to compute the resistances as shown, but as long as the linear resistance is low compared with the contact

Fig. 4. Electrical model of one row.

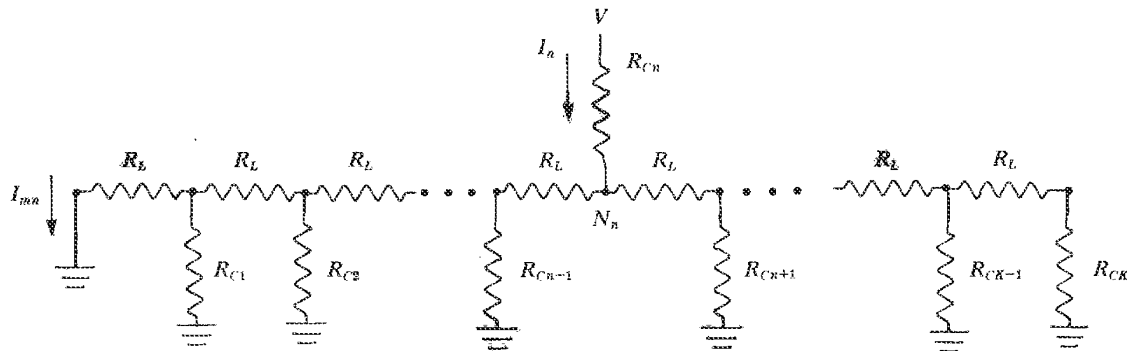

resistance, this is not necessary. If the measured values are used directly, then the worst-case error for a row of N elements is

$$\frac{R_{\text{measured}}}{R_{\text{actual}}} = \frac{R_n + NR_L}{R_n}$$

This is easy to determine because the worst-case occurs when all contacts, except for the one being measured, are open. Other contact closures will only lower the potential of node N_n , increasing the accuracy of the measurement. The error may also be reduced by a factor of two by making contact at both ends of the row.

Performance

Several sensory arrays were constructed with varying range and resolution. Figure 5 shows pressure-resistance curves for two representative devices. Device 1 has a sprayed separator (approximately 10^4 dots per square centimeter). The separator of device 2 is nylon mesh (Leggs, Extra Sheer). The ACS used in device 1 was plated with gold on the contact side. All devices showed good mechanical durability and, after an initial settling period, stable electrical characteristics. (The first prototype, almost a year old, shows no noticeable change in contact resistance.) The highest-resolution device (1) was a 16-by-16 array, 1 cm in area. This is the sensor used with the finger. Sample images of the top of a screw, an elec-

tronic connector, a $\frac{1}{8}$ -in ring, and a cotter pin are shown in Fig. 6.

Method of Use

The touch sensor was mounted on a tendon-controlled finger that has approximately the same shape, size, and range of motion as the human forefinger. Like the human finger, it has three joints: a pivot with two degrees of freedom at the base and two hinge joints with one degree of freedom. These joints are controlled by four pairs of tendons, which are driven from four electric motors mounted behind the base of the finger. Torque and position are measured only at the motors, so that joint torques and angles were computed as described below. The finger and associated motors are mounted on a fixed base, with a small platform, extending just below the finger, on which objects may be placed for testing.

The tendons of the finger are arranged in opposing pairs—one bends the joint, the other straightens it. A system of pulleys keeps the total length of each pair constant. This allows both ends of a tendon pair to be driven from a single motor. The lever arm of the tendon pulling against the joint is kept constant over all angles by winding the tendon over a pulley fixed to the joint. The tendons in the mechanical finger are arranged to give independent control of the torque and angle of each joint. The finger and its control are described in more detail elsewhere (Hillis 1981).

Fig. 5. Performance curves of two sensors.

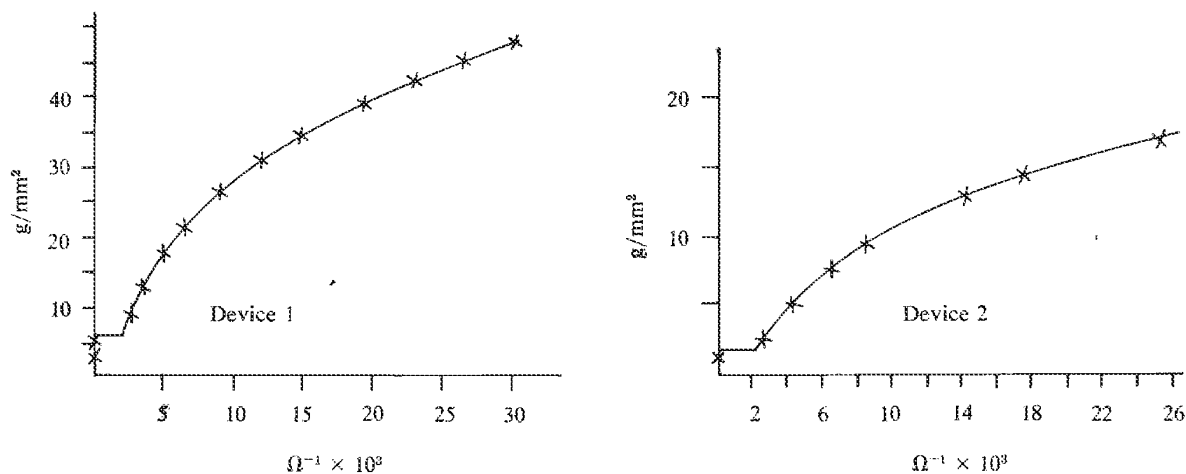

The tendon finger and the touch sensor were used together in the discrimination program. The program used the finger to press and probe the object placed in front of it. Based on how the object felt, the program guessed the shape and orientation of the object. The device was programmed to recognize commonly used fastening devices such as nuts, bolts, flat washers, lock washers, dowel pins, cotter pins, and set screws. The program was written in Lisp and ran on a specially augmented Lisp Machine (Weinreb and Moon 1979), with independent microprocessors to control low-level input/output functions.

The program worked, as will be described, but it never worked well. Its most impressive weakness was that it would confidently identify any object placed in front of it as one of the six test objects. It is, however, a starting point. Many of the techniques used in the discrimination task should be applicable in more sophisticated programs of the future.

Why Touch Is Easier than Vision

In writing the discrimination program, we shamelessly retraced the steps of early researchers in machine vision. There is good reason to believe that these simple techniques have a better chance of

working in the tactile domain than they did in the visual. For one thing, there are far fewer data to be analyzed than in a visual image. This means that even with a high-resolution tactile array, complex processing may be performed in real time. Another factor is that collection is more readily controlled. Since placement and pressure of the fingertip are controlled by the program, analyzing a tactile image is like analyzing a visual image with controlled background, illumination, and point of view.

There is also a third factor responsible for making tactile recognition the easier task: the properties that we actually measure are very close, in kind, to the properties that we wish to infer. In vision, it is only possible to discover mechanical properties (shape, orientation, absolute position) by deducing them from optical properties (shading, projection, reflectivity). In touch, we measure mechanical properties directly.

Active Sensing

There are two possible approaches to any kind of sensory recognition. The first is the *analytic approach*. In the analytic approach, we start with an image of some sort, extract features of the image, and then, from the features, abstract some kind of a

Fig. 6. Sample tactile images from the sensor. Approximate actual sizes of objects shown below images.

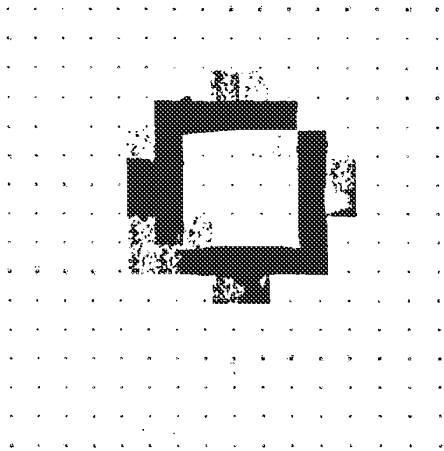

1/8-in. ring 

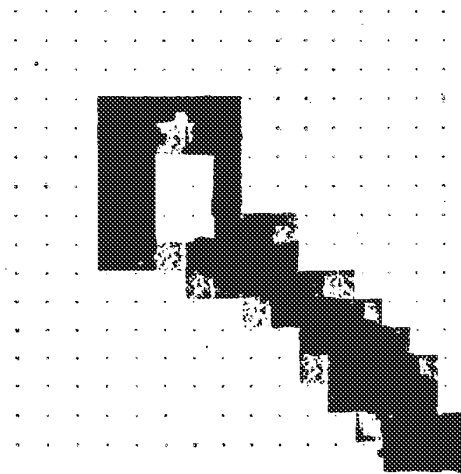

Cotter pin 

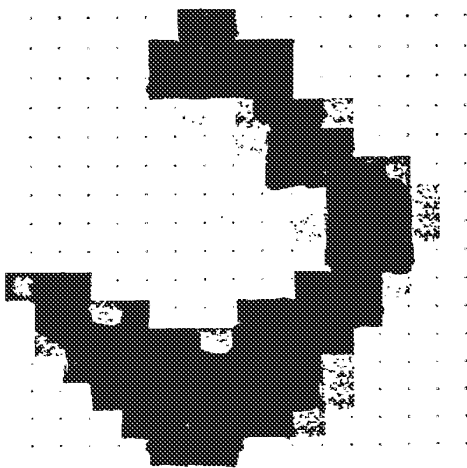

Spade lug 

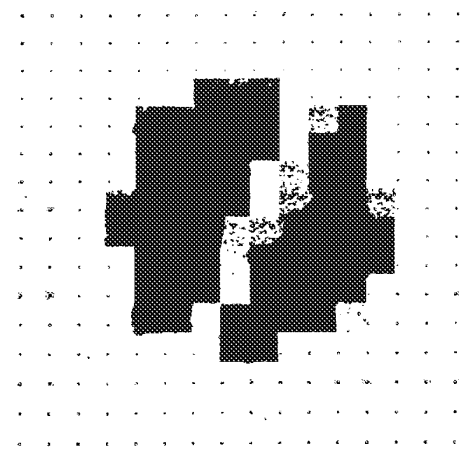

Top of screw with slot 

Fig. 7. Two approaches to recognition.

model of what is shown in the image. The analytic approach is bottom-up, or data-driven. The second approach, the *active approach*, is top-down, or knowledge-driven. When taking the active approach, we begin with a hypothesis of what is in the image. Based on that hypothesis, we make measurements or perform experiments to test the validity of the hypothesis. The results of the theory are then analyzed using the same techniques as the analytic approach, and, based on the result of the analysis, the hypothesis may be modified or confirmed. If it is modified, we try experiments to test the new hypothesis, and so on, until we arrive at a conclusion that agrees with the data. The two approaches are represented schematically in Fig. 7.

We believe that the active approach is more appropriate in the tactile domain. For one thing, the information in a single image is often insufficient for recognition of the object. Moving the finger to make different measurements is the best way of collecting enough data, and in order to decide how to move the finger, the program must have some expectation of what object it is feeling. The program should operate at all times with a hypothesis of what it is feeling. It recognizes the object by actively probing it with the finger, modifying its internal "hallucination" of the object to conform with the measured reality.

The Domain: Nuts and Bolts

For the purpose of testing the sensor, the finger, and the recognition techniques, we chose a restricted range of test objects that the program would be expected to recognize. Specifically, we chose a set of commonly used mechanical fastening devices that are important for potential industrial applications of robotics. Recognition of fasteners and determination of their position and orientation when they are grasped by a manipulator is an important industrial problem. It is also a problem that is unlikely to be solved by machine vision because the hand obscures the object and because forces cannot be seen. In this domain, tactile and visual sensing would complement each other well: vision for locating objects and measuring their absolute position, touch for sensing local shape, orientation, and forces once they are grasped.

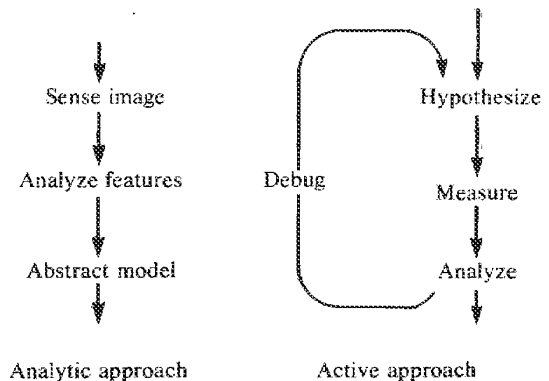

The particular objects, chosen because they have simple shapes that are easy to represent and easy to distinguish, were machine screws, set screws, flat washers, lock washers, dowel pins, and cotter pins. Restricting the range of possible objects to such a small and easily distinguishable subset makes the recognition task less difficult, but it also introduces the possibility that the recognition methods used are not really generally applicable. This may be the case here. Recognizing a larger range of objects would certainly require identifying a richer set of tactile features.

The objects were all small (not more than $\frac{1}{2}$ in. in any dimension). In general, the smallest commonly used size in a given category was used for testing. For example, the machine screw was #0-80 by $\frac{3}{16}$ in. and the cotter pin was $\frac{1}{2}$ in. long by $\frac{1}{16}$ in. in diameter. Using such small objects allowed the entire image to be read in one impression of the sensor. This avoided the problem of coordinating multiple sensor impressions into a single tactile image.

Representation: Describing How Something Feels

Based on features of the test object that make it identifiable by human touch, a simple language was developed for describing the object's tactile properties. Three categories of features, or parameters, were chosen to represent the feel of an object.

Fig. 8. Table of objects.
 + = bump; 0 = depression.







1. Shape. For the fastener micro-world there are only two possible shapes: round and long. The shape may therefore be determined directly from the height/width ratio of the image.
2. Bumps. The locations of local pressure anomalies are expressed in object-relative coordinates, for example, in coordinates relative to the major and minor axes of the image. Bumps may be positive (convex) or negative (concave). (In the implemented program, only the sign and position of a bump are considered significant for matching purposes. There is no intensity information.)
3. Stability. This property indicates how easy it is to roll the object in various directions. (In the program, two Boolean values represent the stability of an object. These indicate whether or not the object rolls freely along each of the primary axes.)

These three parameters were sufficient for distinguishing among any of the objects in the test set. Figure 8 shows which properties were exhibited by each object.

Implementation

The control tasks are divided among a Lisp Machine and five Z-80 microprocessors. Most of the code is written in Lisp and ran on the Lisp Machine. Each microprocessor is dedicated to a simple task with real-time constraints. One scans the tactile image array, while others take specifications for joint motions and execute them in real time. The memories of the microprocessors are directly accessible by the Lisp Machine. This shared memory provides a convenient interface between the two levels of processing. The output of the tactile array, for example, is available as a Lisp array object.

The top-level loop program is just a translation of the active approach diagrammed in Fig. 7. The program begins by assuming that the object is whatever best matches the information that it has so far. This is the "hypothesize" step. It then tests assumptions that it has made about the object and, unless they

		Shape	Bumps	Stability
	Machine screw	Long	+	Yes
	Dowel pin	Long	0	Yes
	Cotter pin	Long	0	No
	Set screw	Round	0	Yes
	Lock washer	Round	+	No
	Flat washer	Round	0	No

are all correct, repeats the process from the beginning. Testing the assumption may involve moving the finger to roll or probe the object, or may just involve making a computation from already collected data.

Flow of control in this process depends on what information is needed. When a property queried is not already known, it is computed or measured. In the process of computing the value, the program may make queries about properties that, in turn, may need to be computed. For example, if we ask an object's shape and it is not known, then it must be computed from the object's dimensions along the primary axes. If these axes are not known, they must be computed from the image of the object. If no image has been read in, the finger must be pressed against the object, and so on. This is "call by need" control flow. It prevents information from being measured or computed unless it is actually needed in the recognition process.

After an image is read in, it must be processed to determine the object's location, the primary axes, and the location of any bumps. The first step in processing the tactile image is the elimination of unwanted detail. This is accomplished by averaging the value of each pixel with those of its immediate neighbors. The image is then contrast-enhanced to two bits per pixel by comparing it to fixed threshold values. If the offset pressure has been chosen properly (see below) the four possible pressure values correspond to background, depressions, primary figure, and bumps.

Next, the aspect ratio and major and minor axes of object are determined. Computation of the aspect

ratio begins with the location of the center of the activated area. For this purpose, all nonzero pixels are taken to be part of the object. The center and the point farthest away from the center determine the major axis of the object. The minor axis is taken to be perpendicular to this. These axes provide an object-relative coordinate system in which it is possible to specify, roughly, the location of bumps and depressions in the image. The bounding rectangle of the object is taken to be the smallest rectangle, with edges parallel to the axes, that contains the image. The aspect ratio of the object is taken to be the aspect ratio of its bounding rectangle.

Moving the Finger

If the image read in is not satisfactory, as is usually the case at first, it is possible to move the finger and read another. An important part of the image analysis involves moving the finger so that an optimal image is sensed. The offset pressure, for example, is adjusted in this manner. Optimally, most of the touched area activates the mid-range of the sensor, allowing bumps and depressions to be detected easily. This is accomplished by reading in an image, computing the median pressure of all points above the noise threshold, and readjusting the finger pressure appropriately. This is repeated several times until an acceptable offset pressure is achieved.

The finger is also moved to measure the stability (resistance to roll) of an object. To measure the object's stability in a given direction, the object is pressed between the finger and the supporting surface by applying a fixed force on the object normal to the plane of the surface. The finger is then moved laterally in the desired direction. (The supporting surface was a thin layer of soft rubber, to prevent sliding.) The stability of the object is indicated by the amount of force necessary to move the finger.

The Matcher

During the hypothesize step, the program must determine which of the objects it knows best matches the known data. For a small set of possible objects,

such as the fasteners, it is not really important that this be done well. For a large set of possible objects, the quality of the matcher may be a determining factor in the speed of recognition. When the hypothesis is chosen by selection of the possibility that best matches the information given, usually the choice that has the largest number of features in common with the known facts is the best choice. In a system with a large number of parameters, other factors may also be taken into consideration. For one thing, some features may be more important than others, either in general or for that particular possibility. Also, the features themselves may not exactly match—a bump may be too large, a shape distorted. In cases such as this, we wish to give the possibility only partial credit for a feature match.

The most obvious way to implement such a matcher would be to use a numerical scoring system, with the weighting of factors for feature importance and partial matches. This approach was avoided for the following two reasons. First, there would have to be a degree of arbitrariness in assigning the numbers: Is a circle a 50% match to a hexagon? Is shape 2.5 times as important as texture, or only twice as important? It is unwise to trust the sums and products of numbers if the numbers themselves are chosen arbitrarily. The second objection is more of a philosophical one—converting a complex set of symbolic structures into a single number causes us to throw away too much information too quickly. Of course, this information must eventually be lost—the matcher must terminate by selecting a single item. But the pruning can be, and is, controlled in a more reasoned manner.

The implemented matcher takes two possibilities at a time and compares them on a feature-by-feature basis. If, for a particular feature, both items match the image to about the same degree, the information is ignored. If one of the items is clearly a better match, the feature is counted in favor of the appropriate item. This procedure is repeated for each feature and then the features themselves are compared in a similar manner. A feature counted toward one item will be cancelled by a feature counted toward another, if they are of approximate importance.

In a large artificial intelligence system, the best match could be computed in parallel. Parallel

marker-propagation schemes, such as the one proposed by Fahlman (1979), would do such a task well. One important assumption, even for the parallel case, is that the binary comparison operator is transitive. Without this constraint, it would be necessary to compare each possible pair of items, a task that grows as the square of the number of items.

The transitivity of the predicate described above can be easily demonstrated, given the transitivity of individual feature comparisons. Assume that there exist three items, A, B, and C, such that $A > B$ and $B > C$. Let $f(x, y)$ be the set of features counted in favor of x when compared with y . Since the individual feature comparisons are transitive,

$$f(A, C) = (f(A, B) \cup f(B, C))$$

and

$$f(C, A) = (f(C, B) \cup f(B, A)).$$

If \gg is the feature set comparison predicate (the second stage of the algorithm above), then $A > B$ implies $f(A, B) \gg f(B, A)$. Also, for any sets a, b, c and d such that $a \gg b$ and $c \gg d$, it must be that $(a \cup c) \gg (b \cup d)$, because features that cancel in the individual sets will also cancel in the union. The assumptions $A > B$ and $B > C$ imply $f(A, B) \gg f(B, A)$ and $f(B, C) \gg f(C, B)$ and, by the union rule, $(f(A, B) \cup f(B, C)) \gg (f(C, B) \cup f(B, A))$. This may be rewritten as $f(A, C) \gg f(C, A)$, which is the criterion for $A > C$. Therefore, the matching predicate is transitive.

This matcher is really overkill for a possibility set of six objects with three parameters each, but it may be necessary if the program is to be extended to a large range of objects.

Proposed Efforts

A program that distinguishes among six objects on the basis of three parameters is not too impressive. Even if it only got one bit from each parameter, it should have correctly recognized eight objects. In the future, tactile recognition programs will have much more complex and more precise represen-

tations of tactile images. Three improvements can help bring this about.

The first is texture recognition. The resolution of the tactile array sensor, while high, is not nearly sufficient for measuring textural differences between, say, paper and glass. Texture sensing requires measuring bulk effects of many tiny surface features. It is most easily accomplished if something is slid over the surface and a pattern of vibrations is detected. This can be likened to sliding a phonograph needle over a record. Sensors of the future may use embedded piezoelectric devices, or it may be possible to use the ACS directly as sort of a carbon microphone. However the information is derived, it must be processed into a useful characterization of the texture of the surface. Of interest is the intensity and periodicity of the signal. These features may be seen directly in the frequency domain. Texture processing may bear more similarity to the analysis of sounds than to the analysis of visual images.

Another improvement might involve thermal recognition: the difference between paper and glass is that glass feels cold. This is not actually because glass is lower in temperature, but because it is a better conductor of heat and so it is more quickly able to carry away the heat generated by the body. We have constructed a small thermal conductivity sensor that works on this principle. In the sensor, a resistive heating element is sandwiched between two temperature-sensitive current sources. Any difference in the temperature of the two sensors is indicated by an easy-to-measure difference in the currents. The sensor is designed to be mounted on the finger in such a way that one temperature sensor may contact the device being tested. As the heat is drawn from the object into the sensor, a difference in temperatures will develop. The primary disadvantage of this first prototype is that it is large ($0.1 \times 0.3 \times 0.2$ in.), resulting in a relatively high thermal mass. This limits both the response time and the minimum size of the object that may be usefully tested.

The third area that shows immediate potential for further research is the coordination of multiple tactile images into a global picture. This is probably the most useful next step in tactile processing. This problem was deliberately avoided in the program

described through the choice of small objects that could be read in a single impression. Such size limitations are probably unrealistic outside the laboratory environment. The first real-world applications of tactile sensing will not be in recognizing objects that fit on the tip of the finger, but rather in orienting known objects grasped with an entire hand. This will require coordinating images from multiple sensors.

We are enthusiastic about the future prospects of automated tactile sensing. What has been described here—the sensor, the finger, and the program—is only an initial approach.

Acknowledgments

I would like to thank the following people for their help, ideas, and enthusiasm: Mike Brady, Tom Callahan, Fred Drenckhahn, Richard Greenblatt, John Purbrick, Gerald Sussman, John Hollerbach, Michael Dertouzos, Margaret Minsky, Laurel Simmons, Patrick Winston, and, most of all, Marvin Minsky.

REFERENCES

Broit, M. 1979 (March). The utilization of an "artificial skin" sensor for the identification of solid objects. *Proc. 9th Int. Symp. Industrial Robotics*.

- Harmon, L. D. 1982. Automated tactile sensing. *Int. J. Robotics Res.* 1(2):00-00.
- Hillis, W. D. 1981 (April). Active touch sensing. A. I. Memo 629, Massachusetts Institute of Technology Artificial Intelligence Laboratory.
- Fahlman, S. 1979. NETL: A system for representing and using real-world knowledge. Cambridge, Mass.: MIT Press.
- Larcombe, M. H. E. 1976 (March). Tactile sensors sonar and parallax sensors for robot applications. Paper delivered at 3rd Conf. Industrial Robot Tech.
- Okada, T. 1979. Object handling system for manual industry. *IEEE Trans. Syst., Man, Cybern.* 9(2).
- Okada, T., and Tsuchiya, S. 1977 (Oct.). On a versatile finger system. *Proc. 7th Int. Symp. Industrial Robots*.
- Purbrick, J. A. (1981). A force transducer employing conductive silicone rubber. Paper delivered at 1st Robot Vision and Sensors Conf.
- Stojiljkovic, Z., and Clot, J., 1977. Integrated behavior of artificial skin. *IEEE Trans. Biomed. Engineering* 24(4):396-399.
- Storace, A., and Wolf, B. 1979. Functional analysis of the role of finger tendons. *J. Biomechanics* 12.
- Weinreb, D., and Moon, D. 1979. *Lisp Machine manual*. Cambridge, Mass.: Massachusetts Institute of Technology Artificial Intelligence Laboratory.

A MULTI-TOUCH THREE DIMENSIONAL TOUCH-SENSITIVE TABLET

SK. Lee, W. Buxton, K.C. Smith
 Computer Systems Research Institute
 University of Toronto
 Toronto, Ontario
 Canada, M5S 1A4

(416)-976-8320

ABSTRACT

A prototype touch-sensitive tablet is presented. The tablet's main innovation is that it is capable of sensing more than one point of contact at a time. In addition to being able to provide position coordinates, the tablet also gives a measure of degree of contact, independently for each point of contact. In order to enable multi-touch sensing, the tablet surface is divided into a grid of discrete points. The points are scanned using a recursive area subdivision algorithm. In order to minimize the resolution lost due to the discrete nature of the grid, a novel interpolation scheme has been developed. Finally, the paper briefly discusses how multi-touch sensing, interpolation, and degree of contact sensing can be combined to expand our vocabulary in human-computer interaction.

1. INTRODUCTION

Rapid advancement of computer technology has opened a variety of new applications. New applications and users mean demands for new modes of interaction. One consequence of this is a growing appreciation of the importance of using appropriate input technologies (Buxton, 1982). Positioning devices are seen to be essential to graphics applications, image transducers are required for pattern recognition in medical diagnosis, touch screens are useful for the education of young children, and the QWERTY keyboard remains the usual standard for text processing. However, the range of input devices available is still quite limited, as is our understanding of how to use them in the most effective manner.

The intent of the research presented in this paper is to increase the vocabulary that can be utilized in human-computer interaction. Our approach has been to develop a new input technology that enlarges the domain of human physical gestures that can be captured for control purposes. In what follows, we will describe the technology, what it evolved from, and some aspects of how it can be used.

2. OVERVIEW

The transducer that we have developed is a touch-sensitive tablet; that is, a flat surface that can sense where it is being touched by the operator's finger. This in itself is not new. Several such devices are commercially available from a number of manufacturers (see Appendix A). What is unique about our tablet is that it com-

Permission to copy without fee all or part of this material is granted provided that the copies are not made or distributed for direct commercial advantage, the ACM copyright notice and the title of the publication and its date appear, and notice is given that copying is by permission of the Association for Computing Machinery. To copy otherwise, or to republish, requires a fee and/or specific permission.

combines two additional features. First, it can sense the degree of contact in a continuous manner. Second, it can sense the amount and location of a number of simultaneous points of contact. These two features, when combined with touch sensing, are very important in respect to the types of interaction that we can support. Some of these are discussed below, but see Buxton, Hill, and Rowley (1985) and Brown, Buxton and Murtagh (1985) for more detail. The tablet which we present is a continuation of work done in our lab by Sasaki et al (1981) and Mehta (1982).

In the presentation which follows, we focus mainly on issues relating to the transducer's implementation. Two important contributions discussed are our method of scanning the tablet surface, and our method of maintaining high resolution despite the surface being partitioned into a discrete grid. Additional technical details can be found in Lee (1984).

3. WHY MULTI-TOUCH?

Touch sensing has a number of important characteristics. There is no physical stylus or puck to get lost, broken, or vibrate out of position. Touch tablets can be molded so as to make them easy to clean (therefore making them useful in clean environments like hospitals, or dirty environments like factories). Since there is no mechanical intermediary between hand and tablet, there is nothing to prevent multi-touch sensing. Templates can be placed over the tablet to define special regions and, since the hand is being used directly, these regions can be manually sensed, thereby allowing the trained user to effectively "touch type" on the tablet.

Without pressure sensing, however, the utility of touch tablets is quite limited. One can move a tracking symbol around the screen, for example, but when the finger is over a light button, there is nothing equivalent to the button on a mouse to push in order to make a selection. Yes, we could lift the finger off the tablet, but that would be more like pulling (rather than pushing) the button. And what if we wanted to drag an item being pointed at, or to indicate that we wanted to start inking? Lifting our finger would leave our finger off the tablet, just when we want it in contact with it the most. There are ways around this problem, but they are indirect. If, however, the tablet has pressure sensing, we can push a virtual button by giving an extra bit of pressure to signal a change in state.

Pressure has other advantages. One example is to control line thickness in a paint program. But why do we want multiple point sensing? A simple example would be if we had a template placed over the tablet which delimited three regions of 9 cm by 2 cm. Where we touch each region could control the setting of a parameter associated with each region. If we wanted to simultaneously adjust all three parameters, then we would have to be able to sense all three regions. An even easier example is using the tablet to emulate a piano keyboard that can play polyphonic music.

4. HARDWARE DESCRIPTION

A brief description of the hardware of the fast multiple-touch-sensitive input device (FMTSID) is introduced here. The design of the hardware is based on the requirements of the fast scanning algorithm and on tradeoffs between software and hardware. Many sensors have been examined for our particular application, however (Hurst, 1974; Hillis, 1982; TSD, 1982; TASA, 1980; JSRC, 1981; Metha, 1982) none seemed to have the properties that satisfy the requirements of a FMTSID. The hardware basically consists of a sensor matrix board, row and column selection registers, A/D converting circuits and a controlling CPU.

The design of the sensor matrix is based on the technique of capacitance measurement between a finger tip and a metal plate. To minimize hardware, the sensors are accessed by row and column selection. Row selection registers select one or more rows by setting the corresponding bits to a high state in order to charge up the sensors while the column selection registers select one or more columns by turning on corresponding analog switches to discharge the sensors through timing resistors. The intersecting region of the selected rows and the selected columns represents the selected sensors as a group. A/D converting circuits measure the discharging time interval of the selected sensors. A University of Toronto 6809 board is used as a controlling CPU. The touch surface of the sensor board consists of number of small metal-coated rectangular-shaped areas serving as sensor plate capacitors. The design of the metal plate area of a unit sensor depends on the measurable capacitance change that results when the area is covered by a finger tip, and on the resolution that can be implemented.

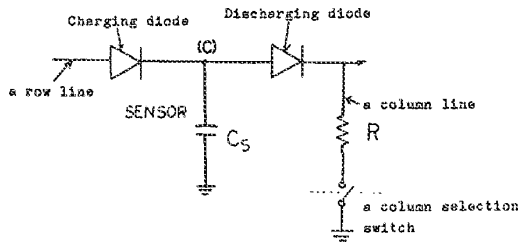

Fig. 1 A model of a selected sensor in the sensor matrix.

In order to select a sensor by row and column access, two diodes are used with each sensor. One diode, connected to the row line, is used to charge up the sensors in the row. It is referred to as the Charging Diode (CD) as shown in Figure 1. The CD also serves to block the charge flowing back to the row line when the row line voltage is dropped to zero. The other diode called the Discharging Diode (DD), connected to the column line, enables discharging of the selected row sensors to a virtual ground. Also the DD blocks charge flow from the sensors in the selected row to the sensors in the unselected rows during the discharging period. The selection of rows, by the row selection procedure, causes the sensors to be charged. The sensors in the column are then discharged through associated timing resistors connected to the column selection switches.

The charges stored in the selected row(s) flow down through the selected switches to the virtual ground of a fast operational amplifier. All the discharging currents are correspondingly added to produce a signal from which the discharging time of all the selected sensors is found by comparison with a threshold voltage.

Pressure sensitivity is incorporated by two measures: First there is the effect, here minor, of compression of the overlying insulator. Second there is the effect of intrinsic spreading of the compressible finger tip as pressure is increased.

The software in the controlling CPU utilizes communication with the host computer to accommodate the interpolation scheme. The clock rate (10 MHz) allows about 10 counts to correspond to the sensor capacitance change due to a touch. But, of course, the capacitance of all the circuitry attached to the column line during the discharging period is much larger than the sensor capacitance. Thus before scanning the tablet for a touch, it is scanned completely in all possible resolution modes when not touched. The values so obtained are stored as references. Touches are identified by the differences between the reference values and the values measured during use.

The capacitance change corresponding to the touch by more than one finger (or by the whole hand) is very large. Thus the number of bits in the counter should be enough to measure the maximum capacitance. However it is unnecessary either to have sufficient bits to measure the entire capacitance including the surrounding capacitances, or to store the corresponding "complete" counter values as references. It is necessary only to have one more bit than the number of bits required to count the value of change in the capacitance rather than the complete value in order to measure the differences of capacitance due to touch. Thus only an 8 bit counter is implemented. The counter enables the measurement of a 7 bit capacitance change regardless of the degree of overflow in the counter.

A facility is also provided for identifying templates applied to the surface of the tablet.

5. SCANNING ALGORITHM

One idea of some significance that can be introduced is to avoid scanning of all the pixels in the tablet which contain no information. For example, scanning all 2048 points of a tablet having a resolution 64 by 32 for fewer than 10 points is really quite a ridiculous idea. In fact, if the number of points to be searched is comparably small, then an improved algorithm, here called recursive area subdivision, can be used. A particular implementation example is described as follows.

Consider a tablet with resolution 8 by 8 to be searched for a touch point as shown in Figure 2. First, check the tablet for touch as a whole region as shown by the area ABCD in the figure. If touch is detected, divide the tablet into two equal regions shown by the line EF and check each of the two regions ABEF and EFGD for touchedness. Select the touched region, region EFGD in this case, and divide this into two equal regions as shown by the division line GH. Continue this process on the touched region until no further division is possible, that is, until a unit sensor, designated as the region PKMO in Figure 2, is reached. The figure also shows the sequence of subdivision in the recursive subdivision scheme.

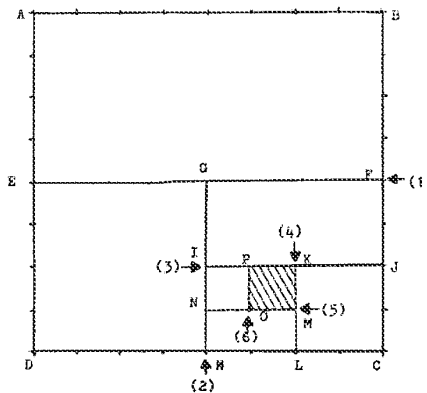

(n)-Sequence of subdivision in binary operation.

Fig. 2 Recursive subdivision operation for 8 by 8 tablet.

Using this algorithm, a search for one point on a tablet having a resolution 64 by 32, requires 22 scanning times, that is

$$2 * \{\log \text{sub } 2\} (64 * 32) = 22$$

If there is no overhead in the recursive subdivision process and scanning begins at the "top of the tree" (that is, with a region in which all pixels are grouped together), then using this scheme, the number of touched points that can be identified in the time that it would take to detect one touch directly (that is, if all pixels are scanned one by one sequentially) is

$$N = \{(64 * 32) \text{ over } 22\} = 186.$$

This shows immediately that the recursive subdivision scheme is much superior to sequential scanning if the number of points to be scanned is fewer than 186.

8. INTERPOLATION

It may seem that the resolution of the hardware is too low for use in graphics applications. However touch intensity and multi-touch sensitivity can be used to enhance resolution. This is possible because the center of a touch can be most accurately estimated by an interpolation utilizing the values of the adjacent sensor intensities.

Direct interpolation schemes for a few cases has been implemented. One of interest is to interpolate an array of 3 by 3 sensors using a touched point in the center. Another is to interpolate all points on the tablet. The later one obviously provides the highest resolution but as a result it simply emulates a single touch tablet with very high resolution.

7. PERFORMANCE

7.1 Sensor

An ideal sensor matrix for a FMTSID would be one that has uniform and small reference values over a grouping level, a large variation of intensity due to a touch, and fast measurement time. The sensor matrix of the prototype, however, has a relatively wide range of reference values. However these values do not change very much over extended periods of time. The results show that doubling the number of sensors in a group in the column direction increases the reference value by a factor of about 1.5. This corresponds well to theoretical estimates. As well the results show that increasing the number of sensors in a group in the row direction, in contrast, does not increase the reference value in general, even if the number of the sensors is doubled in a group. The reference value ranges from 40 (for a single sensor in a group) to 580 (for the entire array of 64 by 32 sensors considered as a group).

In order to account for time and other variations of the reference values, a threshold is included which must be overcome in order for a touch to be detected. The threshold used ranges from 2 to 7 counts depending on group size. Using these threshold values the CPU does not report untouched points wrongly over intervals of at least 3 hours in either sequential or recursive subdivision modes. The recursive subdivision scheme uses 6 different thresholds, consequently it is very unlikely to report a wrong point whereas the linear scanning mode using only a single threshold is likely to be more sensitive.

The intensity of a single touch for a single sensor group varies over the tablet but usually ranges above the threshold value by as much as 15. For a single 64 by 32 sensor group, the intensity varies from person to person but it ranges from the threshold to 124. This maximum is obtained when a palm rather than a finger touches the tablet. Another interesting feature is that the response time becomes faster as the number of sensors in a group becomes larger, and furthermore that for the 64 by 32 sensor group, it is possible to detect of a hand merely placed in the vicinity of the tablet.

7.2 Spatial Resolution

One possible and immediate interpolation scheme is to interpolate a "touched" point with all adjacent values which may not be large enough to be reported as touched. A local array of 3 by 3 points can be used for this interpolation. Some examples drawn on a laser printer (consequently having no intensity scale) are shown in Figure 3. These pictures are produced without feedback, that is, drawn without the operator looking at the output screen. This does not allow the operator to compensate, that is, to select points where data are sparse in comparison with the intended figure, but rather takes direct input from the location of the figure drawn on the input device. The first picture (a) is drawn by moving a finger in a straight line (guided by a ruler) for various angles and the second one (b) is drawn by moving a finger in a line guide by a circle drawn on a template. These tests show that interpolation actually increases the spatial resolution as well as the locatability of a fine point on a screen.

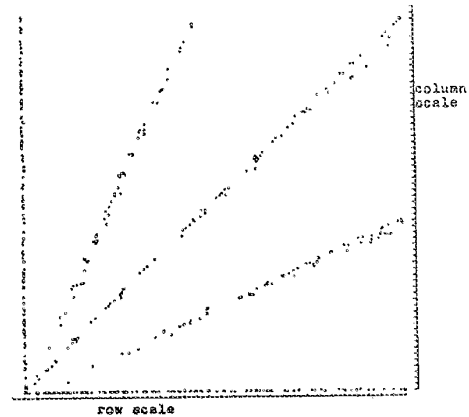

(a) Straight lines drawn by the tablet using 3 by 3 sensor array interpolation. The scales shown represent the boundaries of the actual sensors.

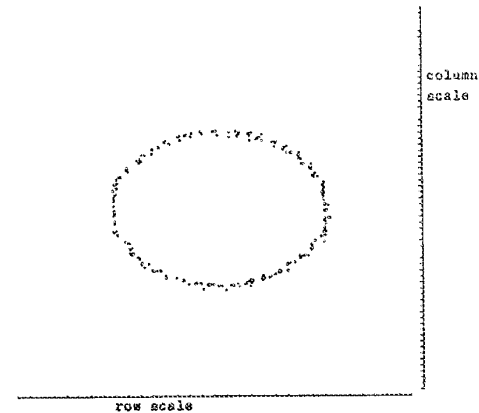

(b) A circle drawn by the tablet using 3 by 3 sensor array interpolation. The scales shown represent the boundaries of the actual sensors.

Fig 3 Points drawn by the tablet using an interpolation method.

Since the spatial resolution in the local interpolation scheme is limited by the number of bits available from the intensities of an array of 3 by 3 sensors, other scheme was considered. In this scheme, all the points from a complete scan of a tablet are interpolated allowing the potential resolution to be almost infinite. However this process simply emulates a projective device and accordingly reports only single point, which is interpolated from all the points on the tablet. However with this scheme, there are a great many ways of pointing to a specific location on a display screen, a feature with some intriguing application possibilities.

7.3 Response Time Delay

The response time delay is the time delay from the beginning of a touch to an output received either by local terminal or by an output device attached to the host computer. For multiple touches, this delay will increase with the number of touches. The prototype used with a 9600 baud-rate terminal to measure time delays. Actual response times were measured several times and averaged for various cases and are tabulated in Table 1.

Case	best	typical	worst
(a) pts/sec msec/pt	17.6 56.8	15.2 65.6	12.8 76.1
(b) pts/sec msec/pt	19.2 52.1	17.2 58.1	16.0 62.5
(c) pts/sec msec/pt	24.0 41.6	22.0 45.5	18.6 53.2

TABLE 1. Actual Response Time Delays

The cases in Table one are to be interpreted as follows:

- a one sensor touched continuously
- b two sensors touched at the same time continuously
- c four sensors touched at the same time continuously

8. CONCLUSIONS

A prototype of a fast-scanning multiple-touch-sensitive input tablet having both the adaptability and flexibility for a broad range of applications has been designed and implemented. Capacitance measurement of individual sensor(s) which can be uniquely addressed using two diodes per sensor, makes it possible to sense both the positions and intensities of one or more simultaneous touches without ambiguity. The sensor matrix is controlled by University of Toronto 6809 board whose serial port is connected to one of the I/O ports of a host computer. Software that utilizes the recursive subdivision algorithm for fast scanning an array of 64 by 32 sensors on the tablet, and that communicates with the host computer, has been implemented and tested.

9. ACKNOWLEDGEMENTS

The research described in this paper has been funded by the Natural Sciences and Engineering Research Council of Canada. This support is gratefully acknowledged.

10. REFERENCES

- Brown, E., Buxton, W. & Murtagh, K. (1985). Windows on Tablets as a Means of Achieving Virtual Input Devices. Computer Systems Research Institute, University of Toronto.
- Buxton, W. (1982). Lexical and Pragmatic Considerations of Input Structures, *Computer Graphics*, 17 (1), 31 - 37.
- Buxton, W., Hill, R. & Rowley, P. (1985). Issues and Techniques in Touch-Sensitive Tablet Input. Computer Systems Research Institute, University of Toronto.
- Hillis, W.D. (1982). A High Resolution Imaging Touch Sensor, *International Journal of Robotics Research*, 1 (2), 33 - 44.
- Hurst, G. (1974). Electrographic Sensor for Determining Planar Coordinates, United State Patent 3,798,370, March 19, 1974, Elographics, Incorporated.
- JSR (1981). Pressure-Sensitive Conductive Rubber Data Sheet, Japan Synthetic Rubber Co., New Product Development Department, JSR Building, 2-11-24 Tiukiji, Chuo-Ku, Tokyo 104, Japan.
- Lee, S. (1984). A Fast Multiple-Touch-Sensitive Input Device, M.A.Sc. Thesis, Department of Electrical Engineering, University of Toronto.
- Metha, N. (1982). A Flexible Machine Interface, M.A.Sc. Thesis, Department of Electrical Engineering, University of Toronto.
- Sasaki, L., Fedorkow, G., Buxton, W., Retterath, C., & Smith, K.C. (1981). A Touch-Sensitive Input Device. *Proceedings of the Fifth International Conference on Computer Music*, North Texas State University, Denton, Texas, November, 1981.
- TASA (1980). Model: x-y 3600 and x-y controller, Model: FR-105 Data Sheet, Touch Activated Switch Arrays Inc., 1270 Lawrence Station Road., Suite G., Sunnyvale, CA 94089.
- TSD (1982). Touch Screen Digitizer Data Sheet, TSD Display Products Inc., 35 Orville Drive, Bohemia, NY 11716.

11. APPENDIX A: TOUCH TABLET SOURCES

Big Briar: 3 by 3 inch continuous pressure sensing touch tablet

Big Briar, Inc.
Leicester, NC
28748

Chalk Board Inc.: "Power Pad", large touch table for micro-computers

Chalk Board Inc.
3772 Pleasantdale Rd.,
Atlanta, GA 30340

Elographics: various sizes of touch tablets, including pressure sensing

Elographics, Inc.
1976 Oak Ridge Turnpike
Oak Ridge, Tennessee
37830

KoalaPad Technologies: Approx. 5 by 7 inch touch tablet for micro-computers

Koala Technologies
3100 Patrick Henry Drive
Santa Clara, California
95050

Spiral Systems: Trazor Touch Panel, 3 by 3 inch touch tablet

Spiral System Instruments, Inc.
4853 Cordell Avenue, Suite A-10
Bethesda, Maryland
20814

TASA: 4 by 4 inch touch tablet (relative sensing only)

Touch Activated Switch Arrays Inc.
1270 Lawrence Stn. Road, Suite G
Sunnyvale, California
94089

A touch sensitive X-Y position encoder for computer input

by A. M. HLADY

National Research Council
Ottawa, Canada

INTRODUCTION

Any input device used in conjunction with a computer controlled display for interactive information exchange between man and computer must function as a position encoder. Input devices for handling two dimensional positional information can be grouped into two general types, one type encoding absolute positions and the other encoding changes in position.

Devices accepting absolute positions rely on a direct mapping of positions from an input surface to a display surface. The input surface is usually a flat plate or tablet on which positions are indicated with a movable hand held stylus. One consideration in developing a device of this type is the location of the input surface with respect to the display surface. The mapping relationship between surfaces is simplified for the user to the extent of being instinctive if the two surfaces are coincident. If the input surface is superimposed on the display surface with a finite separation, the user has to cope with the problem of parallax. A transparent input surface and a one to one mapping scale are implicit in these two arrangements. A third possibility is that the two surfaces are in different physical locations. This makes it necessary for the user to rely on a visual feedback process by observing the mapping of his selected position in relation to the desired position and then modifying his selection to decrease the difference.

The stylus used for indicating positions on the surface is typically an active one which contains a signal sensor, as for example, in the RAND Tablet,¹ or a signal radiator, as in a magnetically coupled device

described by Lewin.² The stylus must be large enough to accommodate the necessary components, and, in addition, present devices require a cable connecting the stylus to the console for signal transmission. This makes some active styli difficult to use with dexterity.

Input devices for encoding position increments do not have separate input surfaces, and their operation depends entirely on visual feedback from the display surface. This type of device consists of a mechanical assembly having at least two degrees of freedom, such as a joy-stick or track-ball, which can be manipulated to indicate changes in the position of a cursor displayed on the screen.

Touch sensitive overlay

Work on the device described in this paper began with several primary objectives which are related to the considerations outlined above. These objectives are:

1. The device must encode absolute positions indicated by the user.
2. The input surface must be as close as possible to the display surface.
3. Positions are to be indicated with a passive stylus, including a human finger.

The first two objectives ensure that the relationships between the positional information that the user must provide and the information he observes on the screen are fundamental ones. This reduces the time and mental effort expended, especially when the device is used for item selection, that is the select-

tion of a sub-set from a set of items shown on the display surface.

Assuming that the first two objectives are met, the third allows one to select items or positions on the screen merely by pointing at them with a finger. Because pointing with a finger is man's most natural method of indicating selection, a touch activated device creates a minimum of distraction for the user. In fact, an ideal implementation of the three objectives listed above would result in an input device that was apparent to the user in function rather than in substance.

Admittedly, the human finger is a rather coarse stylus but the resolution attainable is sufficient for many types of manual information entry. The words or phrases displayed for selection in an information retrieval system could be in a format suitable for this type of input technique. If a conventional keyboard is used in conjunction with the display terminal, a touch activated display overlay reduces the time spent in going from keyboard to display by eliminating the intermediate step of picking up a stylus. In addition, a portion of the display screen could be used as a touch sensitive keyboard with dynamic computer control of the associated key functions. The apparent simplicity, both physically and functionally, of this type of input device is a significant advantage if the user is a young child communicating with a computer-assisted instruction system.

For information entry requiring more resolution than one can obtain with a finger, a suitable passive stylus could resemble an ordinary pencil with its convenient size, light weight, and freedom of movement.

One touch sensitive device³ that has been developed for use with a CRT consists of a number of wires terminating at the front surface of the display tube. Each wire forms the arm of an AC bridge which is unbalanced by body capacitance. A second device, developed by Control Data Corporation, has a series of translucent, touch-activated strips in front of a CRT display.

The approach taken in our case was to use an echo ranging technique with elastic surface waves. Echo ranging with pulsed ultrasonic surface waves has been applied successfully for a number of years in the field of flaw detection for structural materials. The propagation delay of ultrasonic elastic waves has been used as the basis for graphic input devices for a computer. However, these devices do not employ echo ranging and consist basically of fixed sources or radiators with the sensor in a movable stylus. One of these, developed by Woo at IBM,⁴ also uses surface waves on a glass

plate. The Lincoln Wand⁵ provides a three dimensional input capability by using ultrasonic waves propagating in air.

In the device developed at NRC, the radiator and sensor are physically the same piezoelectric transducer which is electrically switched between the driving circuitry and the echo receiving circuitry. Pulse modulated surface waves are produced on a transparent glass plate, and any object contacting the surface reflects some of the wave energy back to the source. The distance from the radiator/sensor to the target is proportional to the time between the radiator pulse and the reception of the echo pulse.

Surface wave characteristics

An elastic surface wave can be represented mathematically as a combination of inhomogeneous longitudinal and transverse waves. This is exemplified by the particle displacements for a surface wave. The particles describe elliptical orbits with the major axis perpendicular to the surface and the minor axis parallel to the direction of propagation, corresponding to the transverse and longitudinal components respectively.

The particle displacements decrease exponentially with depth into the material, the depth decay factor being a function of the wavelength and the material. For glass, the wave energy at a depth of one wavelength is only about three percent of its value at the surface. A practical implication of this result is that, to a close approximation, a plate several wavelengths thick appears as the solid half-space necessary for true surface wave propagation.

Waves on the free surface of a solid half-space, which are also known as Rayleigh waves, are not dispersive and their phase velocity depends only on the properties of the material on which they are propagating. For plate glass the velocity is 10,400 ft/sec.

The amplitude of all elastic waves decreases with distance from the source through three mechanisms—beam divergence, scattering, and absorption. Because a surface wave is essentially a two-dimensional phenomenon, the decrease in amplitude due to beam divergence is proportional to $1/\sqrt{r}$, compared to $1/r$ for spatial waves, where r is the distance from the source. The attenuation due to scattering and absorption is related to that of spatial waves, with the attenuation factor being approximately proportional to frequency in the ultrasonic range. The attenuation coefficient of plate glass measured at 8 MHz is 0.40 nepers/inch.

An interesting property of surface waves is their ability to propagate along curved surfaces. If the radius of curvature is large with respect to the wave-

length, there is only a slight change in attenuation and velocity. This property makes it possible to employ the echo ranging principle described to produce a device which uses the curved front face of a CRT as the input surface, reducing parallax to a practical minimum.

Echo ranging parameters

All systems using echo ranging for target location have similar design parameters. Although considerable effort has gone into the refinement of echo ranging techniques for radar and sonar, the additional complexity and cost of such developments as signal correlation makes them impractical for this application.

For two dimensional space, the stylus location can be determined by measuring its distance from two fixed points or its normal distance from two fixed lines. The latter method was chosen and implemented by alternately scanning the surface in orthogonal directions using linear transducer arrays fixed at the edges of a square plate. This method can provide the stylus location directly in terms of x-y coordinates without additional computation. The line reference method also avoids the problem of edge reflections obscuring valid echoes. Furthermore, with the large beamwidths needed in the first method, it is difficult to achieve an adequate surface wave power density at frequencies in the megahertz range.

The choice of plate material was limited by the transparency requirement. Ordinary plate glass was found to be satisfactory although its attenuation coefficient is higher than that of fused quartz and some optical glass. All the glass tested had several surface flaws per square foot but most of these were shallow enough to be eliminated by localized hand grinding and polishing. The plate size was chosen to provide a usable surface of 10 × 10 inches.

Factors involved in the choice of carrier frequency include the positional resolution, the surface wave attenuation, the radiator beamwidth, the gain in reflected energy for a given target size, and the availability of piezoelectric transducers. A carrier frequency of 5 MHz was chosen for the initial device with the corresponding wavelength on glass being about 0.015 inch.

Radiator/sensor development

One of the most efficient and convenient ways of generating surface waves at frequencies in the low megahertz range is by the mode conversion of a longitudinal spatial wave. This occurs when a longitudinal wave is incident on an interface between two solid

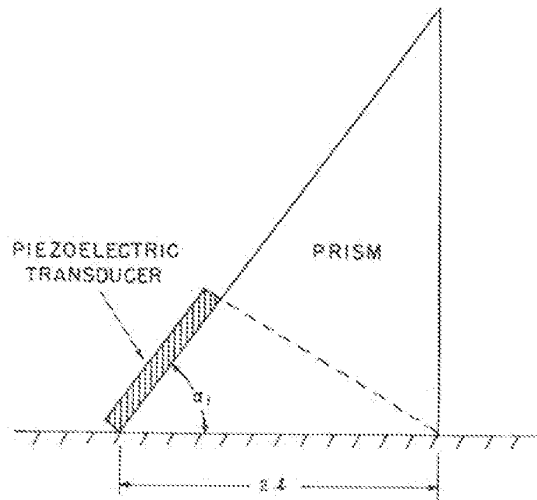

Figure 1—Surface wave radiator/sensor

materials with an angle of incidence large enough that total internal reflection occurs, and no energy is refracted into the second material. In order that the boundary conditions remain satisfied at the interface for this case, inhomogeneous longitudinal and transverse waves are produced in the second material. In other words, a surface wave is generated.

A practical implementation of this, shown in Figure 1, consists of a thickness mode piezoelectric transducer mechanically coupled to a solid prism. Maximum surface wave output occurs for a prism angle, α_1 , such that the spatial period of the surface perturbations corresponds to the wavelength of the resultant surface waves at the frequency of the incident wave. That is, when

$$c_L = c_s \sin \alpha_1$$

where c_L is the longitudinal wave velocity in the prism,

and c_s is the surface wave velocity.

For this optimum angle to be real, the prism material must be chosen so that $c_L < c_s$. One of the commonly available materials that meets this velocity requirement for generating surface waves on glass is an acrylic resin such as Plexiglass or Lucite.

The same configuration also makes an efficient surface wave sensor. In this case, incident surface waves

excite spatial waves in the prism with an angle of propagation determined by the velocity ratio. When the same transducer is used for both sending and receiving, the energy that was internally reflected within the prism during the send interval appears as clutter or noise during the receive interval. Although this excess energy is gradually absorbed by the prism material, its effect can be reduced by modifying the prism shape and coating it with an absorbent material. For the transducers actually constructed, the first two inches of range could not be used because of the clutter.

The piezoelectric transducers are made of a lead zirconate-lead titanate ceramic having a thickness mode electro-mechanical coupling coefficient of 0.66. This material is relatively good for energy transformation in both directions. The bandwidth and mechanical output power of a piezoelectric transducer are related to the mechanical impedance of the materials to which it is coupled. After some experimentation with quarter wave impedance matching transformers and various backing materials, it was decided to sacrifice band-

width for sensitivity by using air-backed transducers bonded directly to the prism. The result was a radiator fractional bandwidth of 20 percent. The parallel components of the electrical input impedance for a small test array constructed in this way are shown in Figure 2.

For an 8 MHz pulse modulated signal with a 1.6 MHz bandwidth, the minimum resolvable stylus movement should be about 0.04 inch. As will be explained later, this resolution was attained but unusable in the first device constructed.

Array design

The method of target location being used requires a line source of waves having uniform amplitude and phase across a ten inch width. To combine separate radiator elements into a linear array with the desired characteristics, the radiation pattern of individual elements must be known. An expression for the directivity characteristics of a prism type of radiator has been derived,⁹ and it yields results similar to the $\sin x/x$ function for spatial radiators. Figure 3 compares values computed for an 8 MHz radiator using this expression with experimentally measured values.

For practical plate dimensions and transducer sizes, the usable surface area lies in the far-field region of the individual elements but in the near-field region of the overall array. By computing the response for various linear array configurations, a radiator width of 0.465 inch, and a spacing of 0.565 inch, were selected.

After the arrays were assembled and tested, the measured radiation pattern was more irregular than the computations indicated. This discrepancy was attributed to the variation in spacing, orientation, and bond characteristics due to assembly tolerances and the variations in transducer sensitivity. The gaps in the pattern were sufficiently large and numerous that it was necessary to add a second set of arrays on the opposite sides of the plate. These are offset with respect to the first so that the beams from opposite arrays are effectively interleaved. The arrays are energized sequentially to avoid mutual interference.

The maximum two-way propagation time for a ten inch usable surface and a two inch buffer zone is about 200 μsec . Therefore, even with four separate arrays, the sampling rate can be greater than 1 KHz, which is more than adequate to follow normal stylus motion.

Electronic circuitry

The signal processing circuitry consists of a radiator driver, an electronic switch, and an echo receiver. The

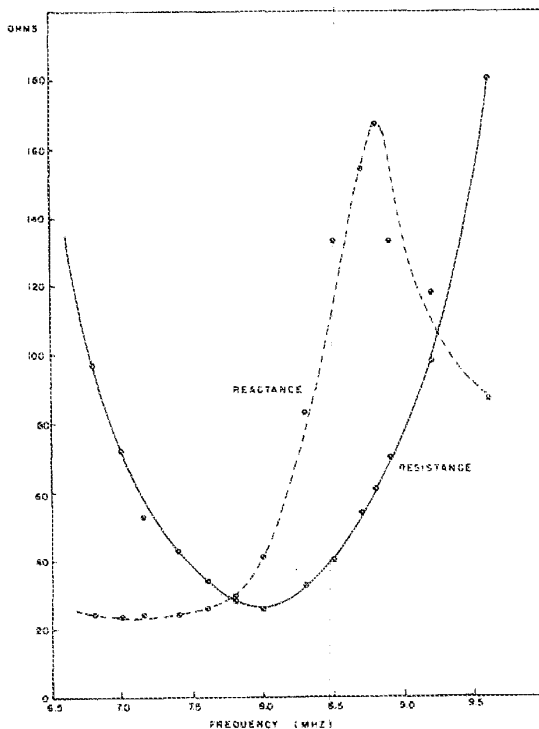

Figure 2—Parallel impedance components for a series connected array of four $1/2 \times 1/4$ inch transducers

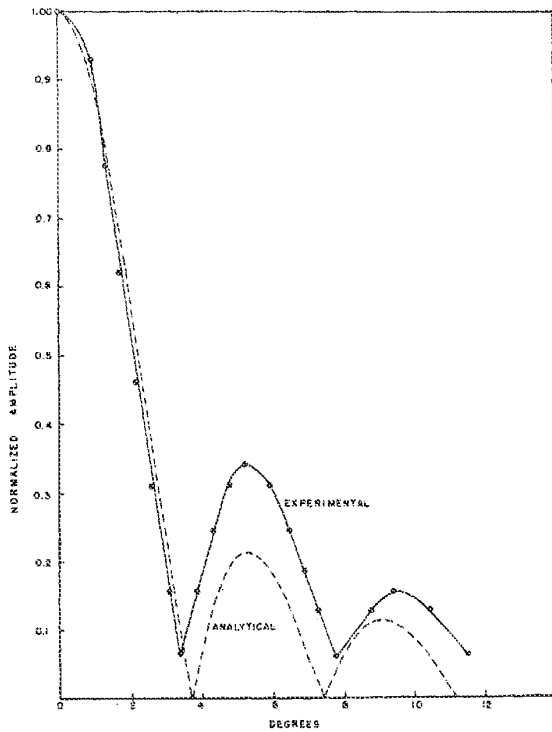

Figure 3—Directivity pattern for a surface wave radiator at 8 MHz with 0.23 inch width

timing circuitry digitizes the signal propagation time, and the control logic maintains the correct operating sequence. Figure 4 shows how these components are interconnected.

The radiator driver and the arrays are matched to 50 ohms allowing them to be connected with standard coaxial cable. The diode switch, with a four-pole double-throw action, permits the four arrays to be multiplexed into a single driver and receiver, and it also isolates the receiver during the driver pulse. The echo receiver consists of an R.F. amplifier followed by a demodulator and a threshold detector. The receiver gain is electronically swept during each scan to compensate for the signal attenuation with range. A range gate rejects echoes originating outside of the designated area. Figure 5 shows the demodulator and threshold detector outputs for a single scan. The signal at the center is the echo from a finger touching the glass.

Echo timing is performed by a free running counter. Both up and down counting are required to digitize scans originating at opposite sides of the input surface. The coordinate grid is considered to have X and Y axes coincident with the edges of the usable surface, the origin being in the lower left corner. Adjustments on the range gates and counting circuitry allow the size and position of the coordinate grid to be varied slightly to permit registration with the grid of an associated display device.

The control circuitry allows two modes of operation: a continuous mode and a discrete mode. In the continuous mode, a Data Ready pulse signals the comput-

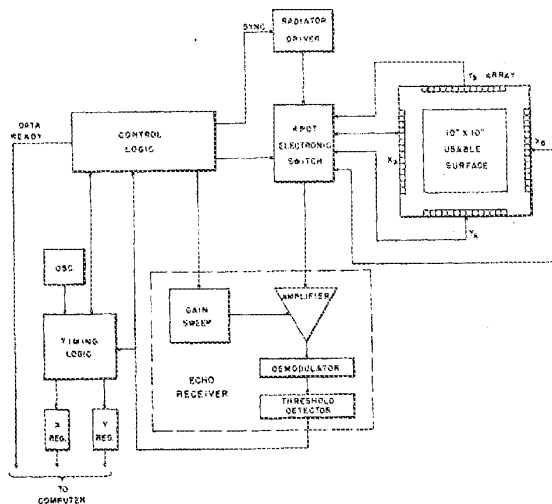

Figure 4—Position encoder block schematic

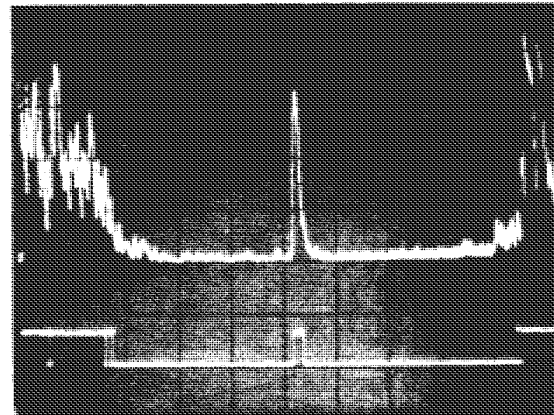

Figure 5—Echo receiver response
Vertical: Upper 0.5 v/div., Lower 5.0 v/div.
Horizontal: 25 μ sec/div.

er for every set of coordinates generated while stylus contact is maintained. In the discrete mode, on the other hand, only the location of the initial contact is transferred to the computer. The stylus must be lifted and repositioned to initiate another data transfer. The discrete mode significantly reduces the amount of data that must be handled without degrading the response time when the device is being used for item selection purposes only.

In applications such as CAI which require a cluster of computer terminals in one location, it becomes feasible to time-share the electronic circuitry among several terminals, thereby decreasing cost per unit.

Device performance

The complete device is shown in Figure 8 with a static display card behind the glass for demonstration purposes. It has been interfaced with a Digital Equipment Corporation PDP-8 computer for testing and evaluation.

Tests have shown that stylus movements of 0.04 inch could be resolved, which corresponds to the calculated value mentioned earlier. However, it was found that a contact area approximately $\frac{1}{4}$ inch in diameter is necessary to ensure operation anywhere on the 10 × 10 inch surface. The contact area must be as large as that to bridge the regions of low sensitivity which result from the irregularities in the surface wave radiation pattern. This means that even though the device has an inherent positional resolution of 0.04 inch, the usable working resolution is considerably lower.

When using the device with a finger, a pressure of

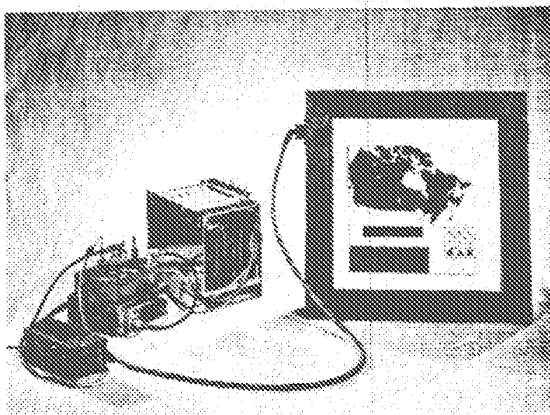

Figure 6—Touch sensitive position encoder

only a few ounces is adequate for operation over most of the surface. In a few places, the pressure has to be increased to enlarge the contact area sufficiently. In the former case, pointing with a finger to items displayed behind a seemingly ordinary glass plate is quite natural, and, except for the parallax, a person can make use of the device without consciously being aware of its presence.

The position encoding is accurate and linear to about 0.5 percent. This figure takes into account the variation in wave velocity due to temperature change and material inhomogeneity, nonlinearity of the radiated wavefront, and the stability of the timing circuits.

Because scratches and marks on the glass produce small echoes which contribute to the background noise level in the receiver, some care must be used to keep the surface clean. The accumulation of fingerprints on the glass also contributes to the background noise. However, this is not a serious problem when the device is used with reasonably clean hands.

The initial device as described has served to demonstrate the feasibility of using surface wave echo ranging as the basis for a touch-sensitive position encoder. The experience gained in constructing and testing the device has been useful in determining where improvements are needed and how they should be implemented. Further computations indicate that a more sophisticated approach to the array design and assembly should improve the radiation pattern uniformity and thereby reduce the present disparity between the minimum contact size and the inherent resolution. Tests have been shown that lowering the carrier frequency to about 4 MHz should increase the signal-to-noise ratio of usable stylus echoes by decreasing the signal attenuation and lowering the sensitivity to surface contamination. The overall consequences of these changes will be to improve the performance with medium and low resolution styli and also to simplify the circuitry, and hence reduce the cost, by using two arrays instead of four. Work is progressing on the construction of a device which incorporates the improvements described.

REFERENCES

- 1 M R DAVIS T O ELLIS
The RAND tablet: A man-machine communication device
AFIPS FJCC Proc Vol 26 325 1964
- 2 M H LEWIN
A magnetic device for computer graphical input
AFIPS FJCC Proc Vol 27 891 1965
- 3 E A JOHNSON
Touch display: A novel input/output device for computers

-
- Electronics Letters Vol 12 1964 Vol 13 1965
- 4 P W WOO
A proposal for input of hand drawn information to a digital system
IEEE Trans on Electronic Computers EC-13 609 1964
- 5 L G ROBERTS
The Lincoln sound
AFIPS FJCC Proc Vol 28 223 1966
- 6 I A VIKTOROV O M ZUBOVA
Directivity diagrams of radiators of Lamb and Rayleigh waves
Soviet Physics-Acoustics Vol 9 1962 Vol 133 1963
- 7 I A VIKTOROV
Rayleigh waves in the ultrasonic range
Soviet Physics-Acoustics Vol 8 1962 Vol 118 1962

A Touch-Sensitive Input Device

L. Sasaki, G. Fedorkow, W. Buxton,
C. Retterath and K. C. Smith¹

Structured Sound Synthesis Project (SSSP)
Computer Systems Research Group
University of Toronto
Toronto, Ontario
Canada
M5S 1A1

INTRODUCTION

In computer music systems there is a continuing problem of finding techniques which allow suitable physical gestures to be used to express musical ideas. This is especially true in performance. This situation exists due to a lack of appropriate input transducers. Conventional computer input devices (such as sliders, joysticks, tablets, and keyboards) are being used to increased advantage (for example, Buxton, Reeves, Fedorkow, Smith, and Baecker, 1980). However, additional research is required to design new devices which lend themselves to the articulate expression of musical gestures. The "sequential drum" of Mathews (Mathews and Abbott, 1981) is one example of work in this area. The proximity sensors used in performance by Chadabe (1980) and the motion sensors used by Pinzarrone (1977) are two other examples. In the remainder of this paper we discuss yet another input device which has been developed as part of the research of the SSSP. The device is a touch-sensitive tablet which is intended to be able to be used as a pointing device, for adjusting performance parameters, and as a percussion-like input device. While the device was designed with music applications in mind, it is far more general in application.

FUNCTIONAL OVERVIEW

The basis of the tablet is a flat surface measuring 30 by 42 c.m. The surface is capable of sensing the point of contact of a finger with a resolution of 64 (horizontal) by 32 (vertical) evenly spaced units. Only one point of contact at a time can be dealt with. The device measures the capacitance at the point of contact and calculates a six-bit digit of proportional magnitude. Since capacitance is determined by the surface area covered at

¹ L. Sasaki is currently with Bell Northern Research, Ottawa, Canada. Fedorkow is currently with Acme Widget, somewhere in New England.

the point of contact, this six-bit digit can be thought of as analogous to pressure (based on the observation that the harder you push, the more surface area your finger covers). This Z value is then transmitted to the host computer, along with the X and Y values identifying the position of the point of contact.

IMPLEMENTATION OVERVIEW

The overall architecture of the device is shown in Figure 1. Here we see that the tablet is made up of four basic modules.

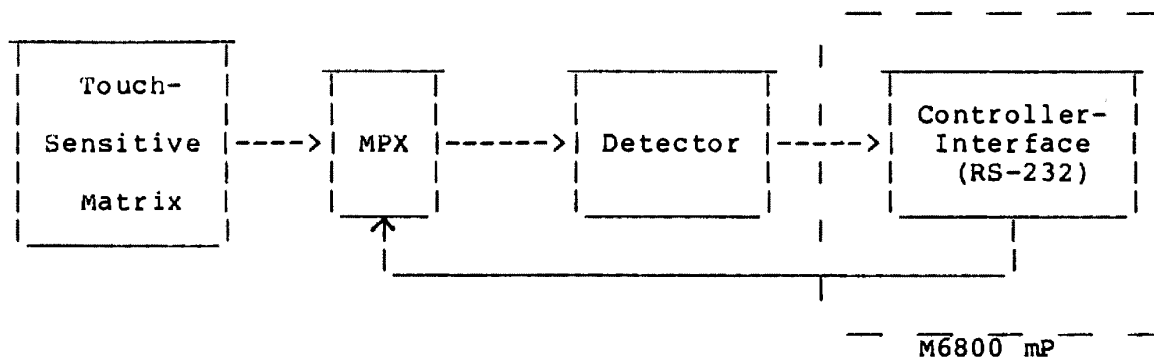

Figure 1. Tablet Block Diagram

The "Touch-Sensitive Matrix" is a printed circuit board etched with a matrix of vertical (64) and horizontal (32) conductive strips. At the edges of this array of strips are multiplexers and capacitance sensors, which are under the control of the microprocessor. Periodically, the microprocessor scans the entire tablet, reading the capacitance of each strip. The values obtained are compared to a set of reference values measured and stored upon start-up. Further processing takes note of strips which show capacitance increased beyond a threshold. Because a finger tip invariably covers several adjacent strips in both the X and Y directions, the controlling software then selects the point of highest capacitance in the largest group of strips as the point of contact. A point of contact for X and Y is computed in this manner. The sum of excess capacitances for all contacted strips surrounding the contact point is scaled to a six bit number and used to indicate the pressure.

As the final step in each scan of the tablet, data is formatted and transmitted to the host, using a standard 9600 baud RS-232 serial link. Because of the amount of processing required, the tablet is scanned only about twenty times per second; this rate

is adequate for tracking hand movements, but it is too slow to be completely satisfactory as an input device for a percussive instrument.

The current version has been implemented using 49 integrated circuits. Included in this is a Motorola M6800 microprocessor which was used to implement the controller-interface module. This was realized using 1968 bytes of ROM.

EXAMPLES OF USE

To date, the tablet has been used by two programs. The first is a test program to demonstrate its sensing potential. It simply maps the three coordinates transmitted by the tablet into parameters of an FM sound being generated by the SSSP synthesizer (Buxton, Fogels, Fedorkow & Sasaki & Smith, 1978). Pressure determines volume (no contact results in silence), vertical position determines pitch, and horizontal position controls timbre (by determining the index of modulation of the FM instrument). The mapping is totally arbitrary. What is important is that the device can reliably sense pressure, and position of single points of contact, as well as track these parameters as the hand slides across the surface. In this example we have used the tablet as a position sensing device, using the absolute values of the coordinates for control purposes.

Our second software effort was to integrate the tablet into the conduct program (Buxton et al, 1980), which is the main performance system of the SSSP. Here the tablet can be used in two ways. First, it can be used as a triggering device. Thus, striking the tablet can be used to initiate events, whether they be single notes or scores. As such, the beginnings of a percussion-like interface is provided. The second use of the touch-tablet is as an alternative to sliders or the mouse for adjusting performance parameters through the control of groups. In this case the tablet can be used as a motion sensitive device, where hand motion in the horizontal and vertical domains can be independently used to increment or decrement the parameters associated with a particular group. Alternatively, the magnitude of the change of parameter values can be made proportional to the magnitude of the distance of the point of contact from the centre of the tablet. Again, the control is two dimensional, working in both the horizontal and vertical domains. Both methods of group control "delta modulate" the parameters associated with the groups in question. The two techniques have different characteristics, however. The first emulates the function of a "mouse" and a tracker-ball. The second lends itself well to combination with the triggering ability of the device. Used in combination, the tablet can be used to initiate an event, and have the properties of that event (such as duration, loudness, pitch, spectral content, etc.) controlled by where the device was hit to cause the trigger. In so doing, the full potential of the device as a

percussion instrument is greatly augmented.

CONCLUSIONS

The tablet described has clear limitations. First, the positional resolution is low, and would need to be increased for it to reach its potential as a general purpose device. It is not yet good enough, for example, to be used as a drawing device where pressure controls line thickness. Basing the design on capacitance sensing is one of the factors in this limited resolution. This also results in some variability in the pressure sensitivity. Clearly other technologies such as measuring conductance or optical techniques need to be investigated. Timing is another area where the resolution suffers. While percussion like gestures can be used effectively to trigger events, a percussionist would be frustrated by the slight lag in response and the inter-event time resolution. Such devices in the future must be designed so that the scanning can be carried out with about 5 ms of resolution. Transmission from the transducer through to the synthesis device must be traversed in about 5 ms. Finally, the most severe limitation is the device's inability to sense and track more than one point of contact at a time. A "polyphonic" version of such a tablet, one that can independently sense position and pressure for several simultaneous points of contact, would definitely be welcome. However, in spite of these limitations, the tablet functions well in its present application and bodes well for the future.

ACKNOWLEDGEMENTS

The research of the SSSP has been funded by the Social Sciences and Humanities Research Council of Canada. Additional funding has also been forthcoming from the National Sciences and Engineering Research Council of Canada. This support, plus the continued physical support from the Computer Systems Research Group of the University of Toronto, is gratefully acknowledged.

REFERENCES

- Buxton, W., Fogels, E., Fedorkow, G., Sasaki, L. & Smith, K. C. (1978). An Introduction to the SSSP Digital Synthesizer. Computer Music Journal 2.4: 28 - 38.
- Buxton, W., Reeves, W., Fedorkow, G., Smith, K. C. & Baecker, R. (1980). A Microcomputer-based Conducting System. Computer Music Journal 4.1: 8 - 21.
- Chadabe, J. (1980). "Solo": A Specific Example of Realtime Performance. In Battier, M. & Truax, B. (1980). UNESCO

Computer Music Report. Ottawa: Canadian Commission for
Unesco, pp. 87 - 94.

Mathews, M. V. & Abbott, C. (1980). The Sequential Drum. Com-
puter Music Journal 4.4: 45 - 59.

Pinzarrone, J. (1977). Interactive Woman-Machine Interaction or
Live Computer Music Performed by Dance. Creative Computing
3.2: 66.

AN EMPIRICAL COMPARISON OF PIE vs. LINEAR MENUS

Jack Callahan, Don Hopkins, Mark Weiser[†] and Ben Shneiderman

Computer Science Department
University of Maryland
College Park, Maryland 20742

ABSTRACT

Menus are largely formatted in a linear fashion listing items from the top to bottom of the screen or window. *Pull down menus* are a common example of this format. Bitmapped computer displays, however, allow greater freedom in the placement, font, and general presentation of menus. A *pie menu* is a format where the items are placed along the circumference of a circle at equal radial distances from the center. Pie menus gain over traditional linear menus by reducing target seek time, lowering error rates by fixing the distance factor and increasing the target size in Fitts's Law, minimizing the drift distance after target selection, and are, in general, subjectively equivalent to the linear style.

KEYWORDS: menus, user interface, empirical studies, directional selection

INTRODUCTION

In presenting a list of choices to the user, most computer system designers have been limited, largely by the available hardware and software, to a linear format. The items are listed from top to bottom, sometimes with an index number for each to the item. Occasionally, the lists are multi-columnned, have multiple items per line, or are even hierarchical (i.e. indented sub-choices), but for the most part lie in a strictly one dimensional structure. Many of these menus are static on the display screen or activated from mouse

Supported in part by the Xerox Corporation University Grants Program, NSF grant #DCR-8219507, and Office of Naval Research grant #N00014-87-K-0307.

[†] Computer Science Laboratory, Xerox PARC, Palo Alto, Calif. 94303.

Permission to copy without fee all or part of this material is granted provided that the copies are not made or distributed for direct commercial advantage, the ACM copyright notice and the title of the publication and its date appear, and notice is given that copying is by permission of the Association for Computing Machinery. To copy otherwise, or to republish, requires a fee and/or specific permission.

©1988 ACM-0-89791-265-9/88/0004/0095 \$00.75

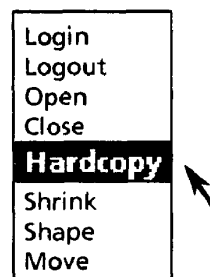

Figure 1: A typical linear menu

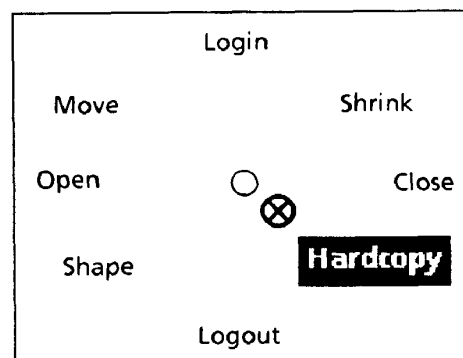

Figure 2: A crude pie menu

actions in two formats: pull-down (menu appears at a fixed label on screen when mouse directed) or pop-up (menu appears anywhere within a fixed area, occasionally the whole screen) [11]. Some systems have used the two dimensional nature of the computer display to the advantage of certain menu applications. Many flight simulation programs, for example, lay out directional headings in a typical compass format.

Item placement in menus has been an important research topic for many years. Menu organization is typically divided into three types [4]: alpha/numeric, categorical (functional), and random ordering. It is generally agreed that the performance of subjects (i.e. time to seek a target) with different placement styles converges with practice [2,10]. Further studies [9] revealed that a functional placement of items is supe-

rior when the task domain is unambiguous to the user whereas an alphabetic organization can be useful in uncertain task descriptions. All of these studies have concentrated on the linear display format.

Has defaulting to a linear format (Figure 1) made some menus easier to use? Harder? By changing the menu format, can users find the item they seek faster? Is a particular menu format faster than other formats even with practice? What type of formats should be tested?

These are important questions for the designers of many systems. Software libraries of menu display routines are widely used as a default by programmers of many window systems and applications. Would it be worthwhile to present items in variable formats or perhaps in another fixed general format like the compass?

A pie menu [7] is a system facility for pop-up menus built into MIT's X windows [5] window management system, and Sun Microsystem's NeWS window system [6] and SunView window system. The pie menu interface supplies a standard library of functions that can be used by programmers to format and display menus in a circular format. The system is written in C and Forth and currently runs on a Sun Microsystems workstation. Items in the menu are placed at

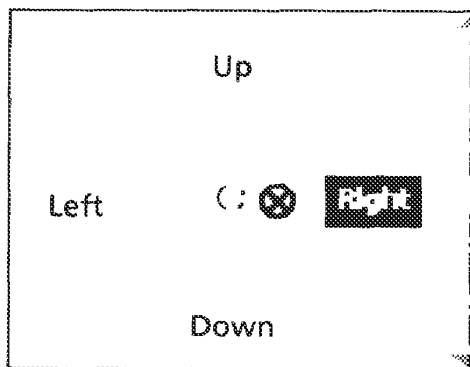

Figure 3: Pie menu activation region

equal radial distances along the circumference of a circle (Figure 2). The starting cursor position is at the center of the menu as opposed to being at the menu title or first item as in traditional pull-down menus. The cursor is under the control of a three button optical mouse on a fixed size moveable pad.

Imaginative menu formats are an inevitable future with the latest advances in window management systems. Window imaging systems using technology from laser printing protocol standards such as PostScript [1] and Interpress [12] will make it possible to display a large variety of non-rectangular shaped windows effectively on a bitmapped display. There are some obvious advantages to this organization for particular applica-

tions: compass directions, time, angular degrees, and diametrically opposed or orthogonal function names are some groupings of items that seem to fit well into the mold of the pie menu design. Alternatively, items with a sequential nature may not benefit and may in fact suffer from such a format. In addition, pie menus consume greater screen area and become polynomially larger than linear menus in both height and width with increased item size and number of items.

Distance to and size of the target are important factors that give pie menus the advantage over traditional linear menus. Even with linear menu initial cursor placement schemes where the cursor may initially be *in the middle* or *at the last item selected*, there remain target items at relatively great distances from the cursor location. Pie menus enjoy a two fold advantage because of their unique design: items are placed at equal radial distances from the center of the menu and the user need only move the cursor by a small amount in some direction for the system to recognize the intended selection. The advantages of decreased distance and increased target size can be seen as an effect on positioning time as parameters to Fitts's Law [3].

The distance to an item in any menu style can be defined as the minimum distance needed to highlight the item as selected. In both menu styles, this is defined by a region rather than a point. This region is typically of greater area than the actual target (Figure 3). Once the cursor has entered the region, the item is highlighted as feedback to the user.

<i>Pie</i>	<i>Linear</i>	<i>Unclassified</i>
North	First	Center
NE	Second	Bold
East	Third	Italic
SE	Fourth	Font
South	Fifth	Move
SW	Sixth	Copy
West	Seventh	Find
NW	Eighth	Undo

Table 1: Task groupings

EXPERIMENT

Introduction and hypothesis

This paper describes a controlled experiment to test two hypotheses: that pie menus decrease the seek time and error rates for menu items and that pie menus are especially useful in menu applications suited for a circular format, diametrically opposed item sets (e.g. open/close), directions (e.g. up/down) or even linear sets of items and conversely linear menus are useful for sets of linear items (e.g. one,two,three,etc.).

The experiment is a 2x3 randomized block design. Each cell is an element of the cross product of menu and task type. A typical pie task would be the compass example because it seems best suited functionally for pie menus. List of elements, like OPEN/CLOSE and UP/DOWN, whose meanings are antonyms are also classified as pie tasks. Lists, like numbers, letters and ordinals, are best suited for linear menus and are thus classified as linear tasks. Groups of menu items that have no relation to each other fall in the unclassified category. Table 1 shows an example of the groupings.

There are a total of 15 menus, a group of 5 for each task type. Subjects perform the experiment for all cells in the experiment matrix in random order in accordance with a randomized block design [8]. The subjects see each of the 15 menus four times, a total of twice in each menu format. Each cell in the experiment consists of 10 menus. Each subject therefore sees a total of 60 menus. Targets are uniformly distributed over the eight possible items.

Pilot study results

A pilot study of 16 subjects showed that users were approximately 15% faster with the pie menus and that errors were less frequent with pie menus. Statistically significant differences were found for item seek time but not task type. Subjects were split on their subjective preference of pie and linear menus. Some commented that they were able to visually isolate an item easier with linear menus and that it was hard to control the selection in pie menus because of the sensitivity of the pie menu selection mechanism. These subjects tended to be the most mouse naive of all whereas those who had heard of or seen a mouse/cursor controlled system but had not used one extensively tended to prefer pie menus. The most mouse naive users, while finding linear menus easier, tended to be better at pie menus and commented that with practice, they would probably be superior and in fact prefer the pie menus because of their speed and minimization of hand movement with the mouse. Not surprisingly, therefore, most of those preferring linear menus did not have a strong preference on the scaled subjective questionnaire.

Subjects

Subjects were volunteers from the University of Maryland Psychology Department Subject Pool. All 33 subjects were undergraduate students with little or no mouse experience. They were rewarded with 1 extra credit point for participating.

Materials

As stated, pie menus run on a Sun Microsystems Workstation as part of an enhanced version of MIT's X win-

dows system. The screen is a 19-inch bitmapped high resolution black-and-white display. Cursor location is controlled by a three button optical mouse on a moveable mousepad made of a specially formatted reflective material.

Procedures and problems

Some changes were made from the pilot design of the experiment: a better distribution of menu targets and doubled number of menu trials, though the total number of menus remained constant.

The process of selecting items from a pop-up menu, regardless of format, can be characterized in three stages: invocation, browsing, and confirmation. To make a selection, the user invokes the menu by pressing a mouse button (*invocation*), continues to hold the mouse button down and moves to an item which is then highlighted (*browsing*) and releases the mouse button confirming the selection (*confirmation*).

The typical sequence of events for a subject is as follows:

- The target is displayed to the user in a fixed text window at the top of the screen. The cursor associated with the mouse is marked by a small hash mark "x" on the display screen.
- The user invokes the menu by pressing and holding any one of three mouse buttons. The menu appears with the cursor location unchanged (except near screen boundaries where the cursor must "jump away" to accommodate the menu). The cursor is located in the center or menu title region of pie and linear menus respectively.
- With the mouse button still depressed, the user moves the cursor with the mouse towards the textual target as indicated. Selections highlight as the cursor moves into distinct activation regions. As noted, the activations regions for pie menus are "pie" shaped sections that extend to the screen boundaries and are rectangular sections extending horizontally towards the screen boundaries for linear menus.
- Once selection is made, the user releases the mouse button to confirm the selection. The menu disappears from the display screen. The cursor remains at the screen position relative to the selection location. If the selection is correct, the process begins again with a new target and possibly a new menu style. Otherwise, if the selection is not the requested target, an audible "beep" tone is heard and the user attempts the task again.

Basically, the computer posts the target name at the

top of the screen, the user invokes the current menu, moves to the target item, and confirms the selection by releasing the mouse button. This sequence, called a task, is repeated 60 times by each subject. Each subject saw 6 sequences of 10 menus each. In each ten menu sequence, the menu type was the same, either pie or linear, and since there are only 5 menus per task type, each menu appears twice in the sequence.

	Task type			Mean _{menu}
	Pie	Linear	Unclass.	
Using pie menus	2.20	2.18	2.40	2.26
Using linear menus	2.68	2.30	2.94	2.64
Mean _{task}	2.44	2.24	2.67	

Table 2: Target seek time (sec) means per cell, menu type, and task type

	<i>F</i>	<i>PR > F</i>
Menu type	16.23	0.0003
Task type	6.93	0.0030
Menu type X Task type	2.82	0.0750

Table 3: repeated measures analysis of variance results for target seek time

The 10 menu sequences correspond to the cells in the experiment table design. Each subject performed a sequence for all 6 cells in random order. 60 data points are collected per subject. A total of 33 subjects performed the experiment for a total of 1980 data points.

For each task, the time from the first mouse button down to the correct target selection is the seek time for the item. If the user selected the wrong item, the time is included in this interval. The number of errors made as well as the sub-interval times when errors are made is recorded during the experiment by the system. All subjects performed the test adequately and no person failed to finish the assignment.

RESULTS AND DISCUSSION

A repeated measures analysis of variance was performed on the data. Table 2 shows the means per cell, per row, and per column. Table 3 displays the repeated measures ANOVA results. A Tukey analysis reveals that there is a statistical significant difference ($P < 0.01$) between overall menu type performance and task type performance in target seek times. Pie tasks and linear tasks did not significantly differ from each other, but both organizations are an improvement over the unclassified menu tasks. Slight statistical significant difference ($P = 0.075$) between cells in the experiment design is also observed. No other interaction was ob-

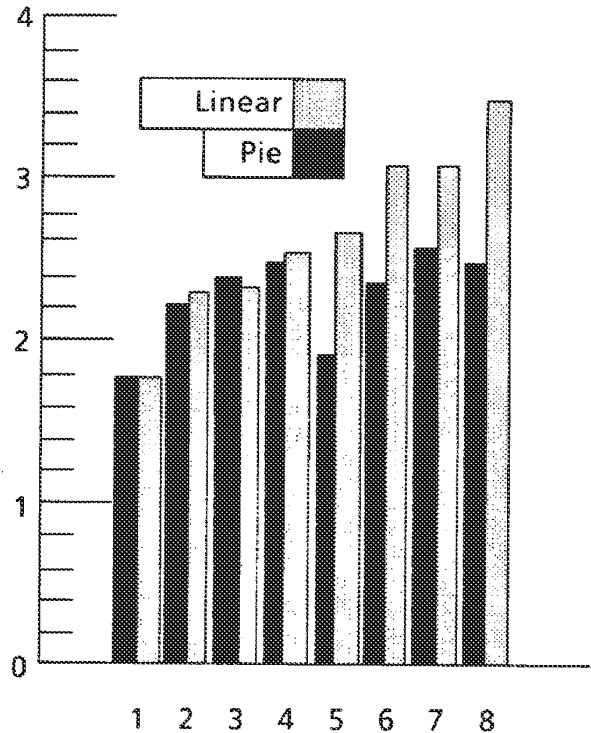

Figure 4: Target location (x) vs. seek time (y) in seconds

served to be significant.

The statistically significant difference between menu type performance is the central result of this study. The task type difference reiterates earlier study results [2,9] that showed that some organization is helpful. Furthermore, the slight interaction between menu types and task types tends to confirm the hypothesis that certain task groupings perform well with particular menu formats. The reason for a lack of strong correlation is evident in the lower mean for pie menus even on linearly grouped tasks.

Figure 4 displays the target location by item plotted against the mean seektime. The mean seektime across target location for pie menus is fairly constant. As expected for linear menus, the mean seek time increases proportionally to the distance of the target from the initial cursor location. Analysis of seektime vs. number of menus seen shows that no strict convergence occurs between the two menu styles, though mean seek-times did decrease for both pie and linear menus with practice.

With error times removed from the results (measuring time from menu invocation to *first correct* choice), the menu styles compared relatively the same as the comparison which includes error times because of the error rates.