

- [54] **ELECTRICALLY INTEGRATED TOUCH INPUT AND OUTPUT DISPLAY SYSTEM**
- [75] Inventor: **Juan de J. Serrano**, Seymour, Conn.
- [73] Assignee: **General Electric Company**, Louisville, Ky.
- [21] Appl. No.: **69,001**
- [22] Filed: **Aug. 23, 1979**
- [51] Int. Cl.<sup>3</sup> ..... **G06F 3/14**
- [52] U.S. Cl. .... **340/712; 340/365 C; 340/365 VL**
- [58] Field of Search ..... **340/712, 365 C, 365 VL, 340/756, 765**

[56] **References Cited**

**U.S. PATENT DOCUMENTS**

3,207,905	9/1965	Bray	340/712
3,322,485	5/1967	Williams	340/784
3,757,322	9/1973	Barkan et al.	340/712
3,971,013	7/1976	Challoner et al.	340/712
4,017,848	4/1977	Tannas, Jr.	340/712
4,078,257	5/1978	Bagley	340/712
4,112,429	9/1978	Tsuha et al.	340/712
4,121,204	10/1978	Welch et al.	340/712
4,186,392	1/1980	Holz	340/712

Primary Examiner—Marshall M. Curtis  
 Attorney, Agent, or Firm—Bernard J. Lacomis; Radford M. Reams

[57] **ABSTRACT**

A user touch input and output display system which combines elements of a capacitive attenuator type touch

switch and a display into a single system. In one embodiment type, one of the electrodes of the display performs double duty as a rear pad, for example a transmitter pad, of a capacitive attenuator type touch switch. The other rear pad necessary for operation of a capacitive attenuator touch switch may either be within the same chamber or envelope as the display electrodes, or may be outside the chamber. The display may for example be a gas discharge display, and the shared electrode does double duty as the display anode and a touch switch transmitter pad. Alternatively, the display may be a liquid crystal display. In embodiments where the other rear pad is within the chamber, to avoid noise interference to the touch switch caused by the gaseous discharge, it is preferable to operate the system in a display mode and in a touch switch mode at different times. During the touch switch mode, the display anode which also serves as the touch switch transmitter pad is supplied with an effectively AC signal. During the display mode, the display anode may be supplied with either a pulsating or a steady DC voltage. In another embodiment type, a liquid crystal display is driven by an AC voltage source having a high series impedance, and a display electrode is capacitively coupled to a touch pad. When a user touches the pad, sufficient signal is shunted to ground to drop the voltage across the display electrode below that necessary to maintain visible energization.

30 Claims, 11 Drawing Figures

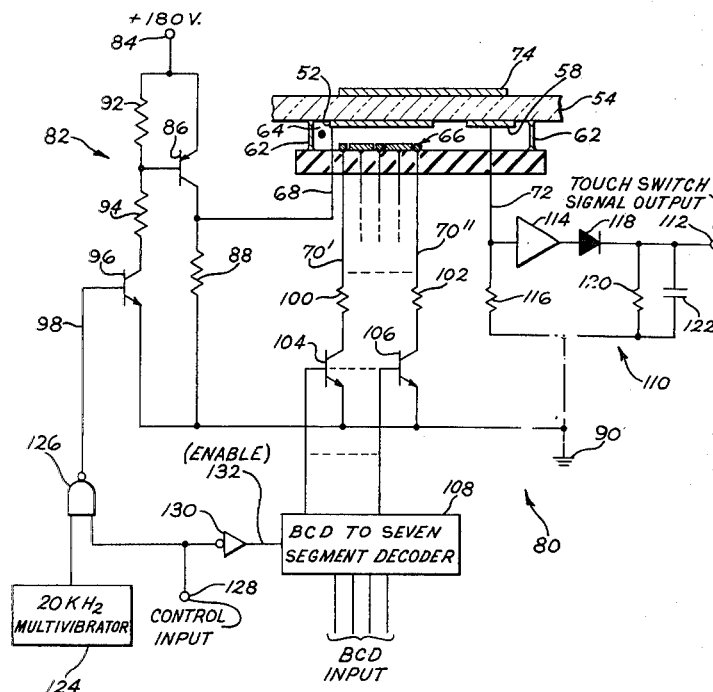

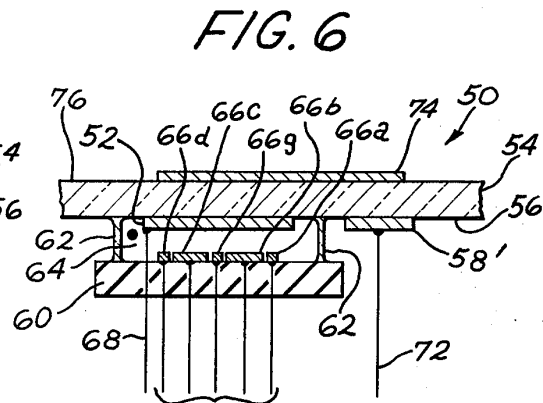
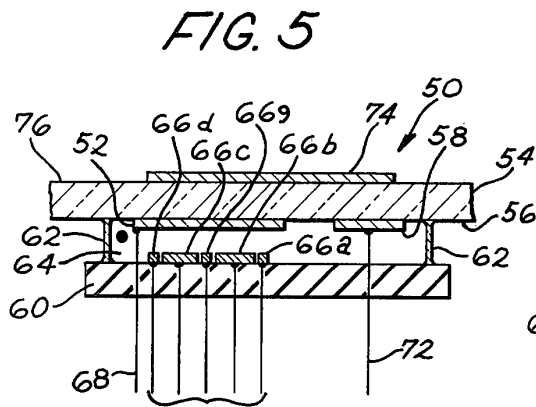
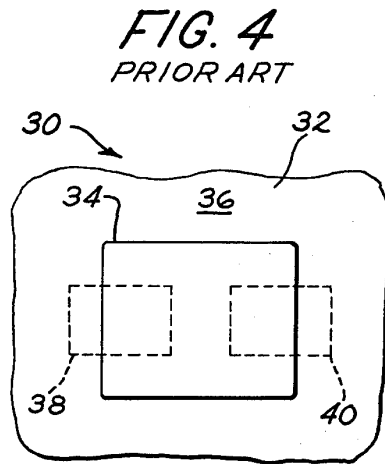
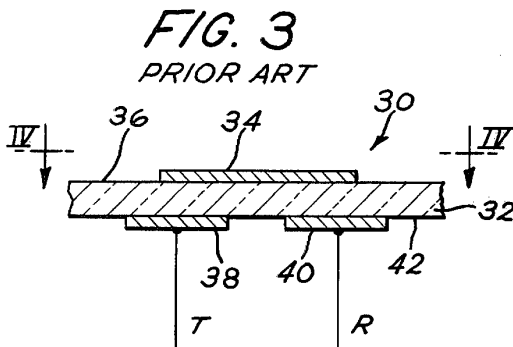
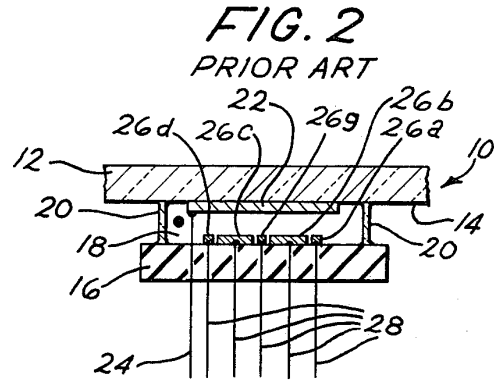
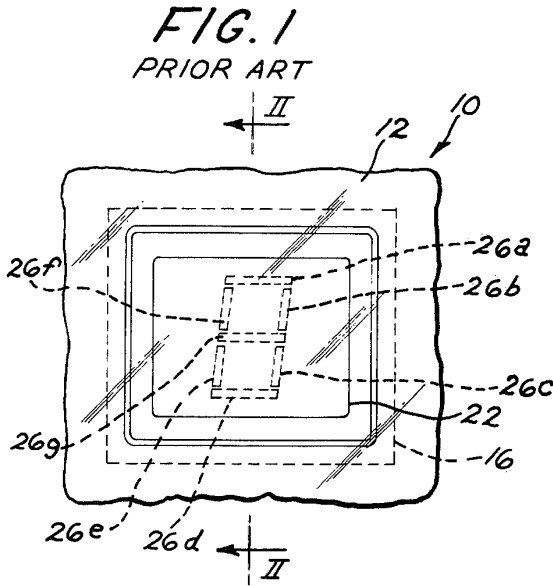

FIG. 7

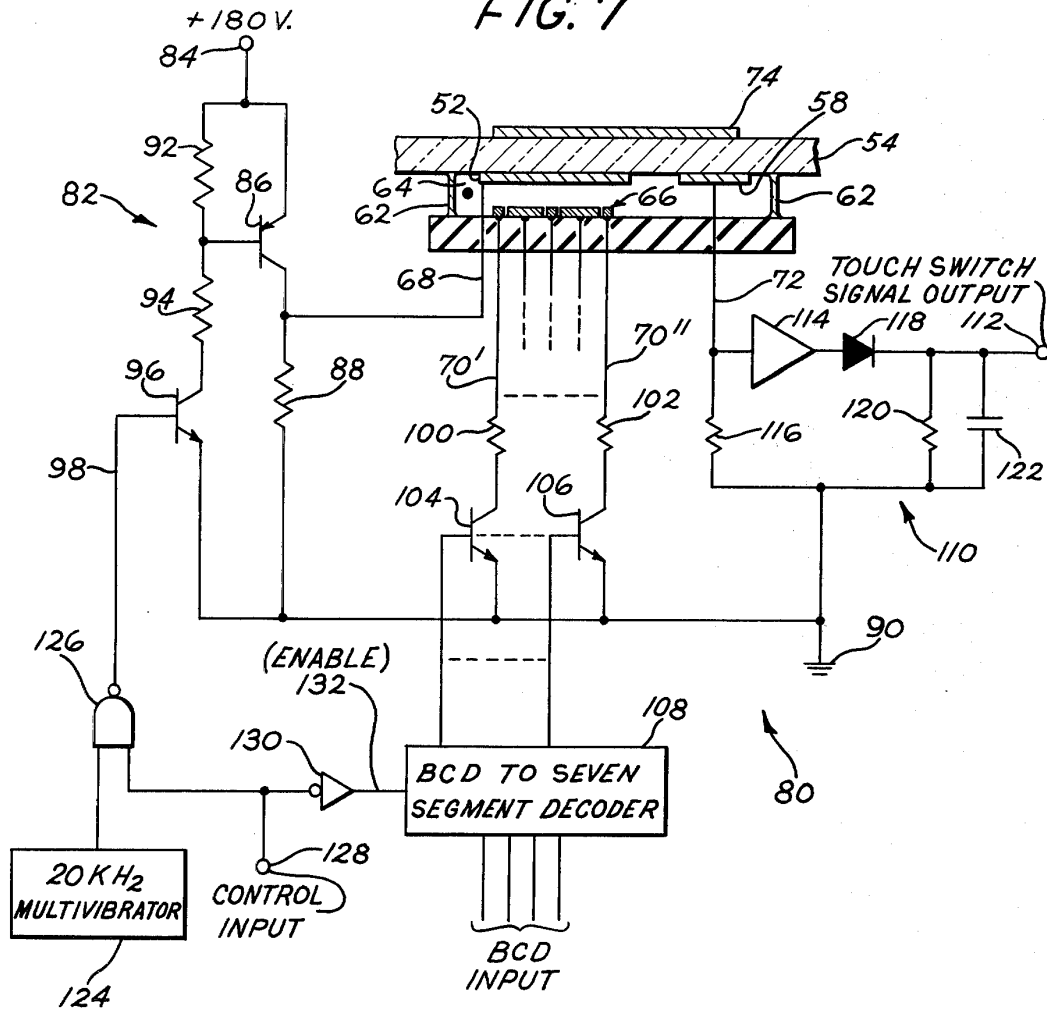

FIG. 8

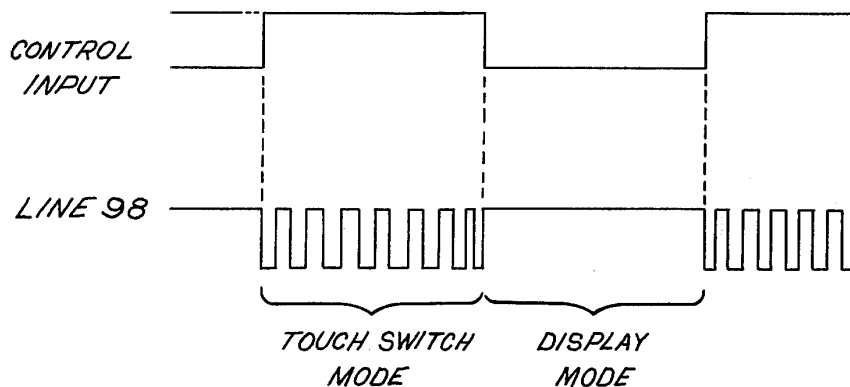

FIG. 9

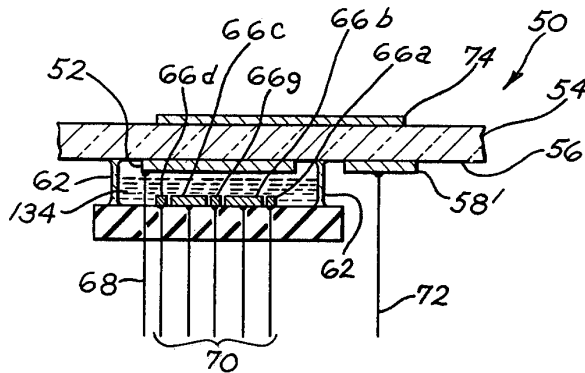

FIG. 10

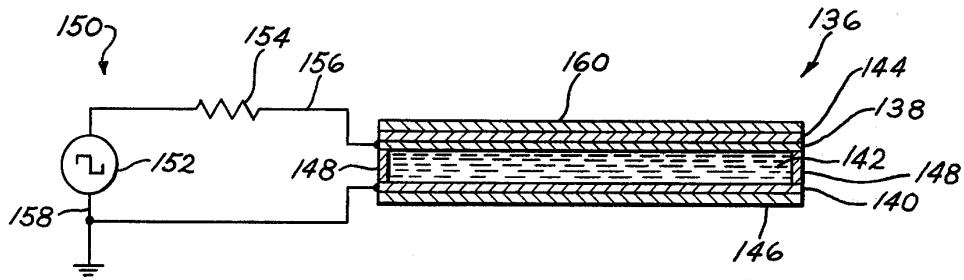
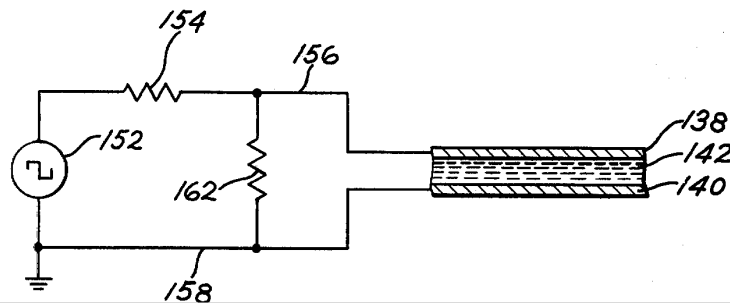

FIG. 11



## ELECTRICALLY INTEGRATED TOUCH INPUT AND OUTPUT DISPLAY SYSTEM

### BACKGROUND OF THE INVENTION

The present invention relates to input/output systems which conveniently combine or integrate a touch switch for data entry and a display device for data output.

It has long been recognized that in many control applications it is desirable to combine a display such as an indicator light, with a switch actuating element essentially superimposed over the display. One common approach is to provide a display lamp or the like and a more or less transparent switch superimposed over the lamp. Advantages of such an approach include immediate feedback to the user at the physical location and moment of contact, savings in required panel area where input and output devices can be collocated, and potential savings in cost where one device serves the functions of two devices at less than the total cost of two devices.

Examples of devices wherein data entry switches and display devices are integrated in various manners and to various degrees are provided by the following U.S. Pat. Nos. 3,207,905—Bray; 3,757,322—Barkan et al.; 4,017,848—Tannis, Jr.; 4,078,257—Bagley; 4,112,429—Tsuha et al and 4,121,204—Welch et al. In each of the devices disclosed in these patents, the data input switches and the display output elements are generally separately identifiable devices with merely a physical connection between the two.

Other integrated entry/display systems have been disclosed wherein there is electrical interaction between the data input elements and the display output elements. One example of this general approach is a technique wherein an electrically conductive area (such as a NESAspot) is applied to the outer envelope of a cold cathode gaseous discharge lamp such as a neon lamp. An exciting voltage just below that which is necessary to trigger conduction is applied to the lamp electrodes. With the display device thus just ready to trigger, an external electric field disturbance occasioned by the proximity of a finger to the NESAspot triggers conduction in the display. In addition to merely providing a visible indication, the conduction may be used to signal other circuitry that the spot has been touched. Thus a single device serves as both a switch and a display.

Another example of an integrated entry and display device with electrical interaction between the display and a touch switch, and one which is particularly relevant in the context of the present invention, is disclosed in the Challoner et al U.S. Pat. No. 3,971,013. The Challoner et al device includes an AC driven gas discharge panel display, and at least one conductive touch key located proximate the display to pick up an AC voltage from a stray field generated by the gas discharge panel display. The Challoner et al device further includes an electrical connection to the conductive touch key for the purpose of detecting a drop in the AC voltage level of the key which occurs due to the proximity of an operator's finger.

### SUMMARY OF THE INVENTION

It is an object of the present invention to provide an effective integrated entry/display system where an

electrical interaction between a display device and a data input touch switch is employed to advantage.

It is another object of the invention to provide such an integrated entry/display system wherein a savings in operating circuitry as well as physical structure of the entry/display device may be realized through the sharing of common elements.

Briefly stated, and in accordance with one aspect of the invention, there is provided an integrated entry/display system including a dielectric panel and a display having at least one electrode adjacent one side, for example a rear side, of the dielectric panel. In the illustrated embodiments, the display is shown both as a gas discharge display and as a liquid crystal display. Also adjacent the one side of the dielectric panel, but electrically insulated from the one display electrode, is a capacitive attenuator touch switch rear pad. A capacitive attenuator touch switch front pad is adjacent the other side (front side) of the dielectric panel and arranged for capacitive coupling through the panel with both the one display electrode and the touch switch rear pad. Suitable circuitry is provided for operating the display by applying a suitable signal to the one display electrode; and additionally for operating the one display electrode, the touch switch rear pad and the touch switch front pad all together as a capacitive attenuator touch switch by applying an effectively AC exciting voltage to one of the electrodes on the one side (rear side) of the dielectric panel and sensing the resultant signal capacitively coupled to the other of the electrodes on the rear side of the dielectric panel. To achieve capacitive attenuator touch switch operation, the circuitry operates to detect a decrease in the coupled signal when the touch switch front pad is touched.

Thus, the one display electrode serves dual functions as an element on the display and as an element of the touch switch. Preferably, this display element is the anode of a gas discharge display and also serves as the transmitter pad of a capacitive attenuator touch switch.

In the event the display is a gas discharge display, it may have a single anode and a plurality of cathodes, for example seven cathodes arranged in a configuration known as a seven segment display for the purpose of displaying numerical digits.

The capacitive attenuator touch switch rear pad may be either positioned inside the same sealed, gas-filled envelope or chamber as the electrodes for the display, or it may be located outside the gas-filled envelope. This is largely a matter of choice of fabrication technique, but in cases where the touch switch rear pad is outside of the gas-filled chamber, the problem of minimizing interference of the gas discharge display with the capacitive input touch switch is minimized.

In accordance with another aspect of the invention, in cases where operation of the display interferes with the touch switch, as likely would be the case where the touch switch rear pad is positioned within the gas-filled chamber which, when the display is operating, contains ionized gas, the capacitive attenuator touch switch is utilized for presence detection at times when information is not being displayed and the display is therefore quiescent.

In accordance with another aspect of the invention, applicable in particular to a liquid crystal display, the display is driven by an AC voltage source having a high series impedance. One of the display electrodes is capacitively coupled to a touch pad such that when the touch pad is touched sufficient signal is shunted to

# Explore Litigation Insights

Docket Alarm provides insights to develop a more informed litigation strategy and the peace of mind of knowing you're on top of things.

## Real-Time Litigation Alerts



Keep your litigation team up-to-date with **real-time alerts** and advanced team management tools built for the enterprise, all while greatly reducing PACER spend.

Our comprehensive service means we can handle Federal, State, and Administrative courts across the country.

## Advanced Docket Research



With over 230 million records, Docket Alarm's cloud-native docket research platform finds what other services can't. Coverage includes Federal, State, plus PTAB, TTAB, ITC and NLRB decisions, all in one place.

Identify arguments that have been successful in the past with full text, pinpoint searching. Link to case law cited within any court document via Fastcase.

## Analytics At Your Fingertips



Learn what happened the last time a particular judge, opposing counsel or company faced cases similar to yours.

Advanced out-of-the-box PTAB and TTAB analytics are always at your fingertips.

## API

Docket Alarm offers a powerful API (application programming interface) to developers that want to integrate case filings into their apps.

## LAW FIRMS

Build custom dashboards for your attorneys and clients with live data direct from the court.

Automate many repetitive legal tasks like conflict checks, document management, and marketing.

## FINANCIAL INSTITUTIONS

Litigation and bankruptcy checks for companies and debtors.

## E-DISCOVERY AND LEGAL VENDORS

Sync your system to PACER to automate legal marketing.