

Essentials of
NUCLEAR MEDICINE
SCIENCE

MAIA Exhibit 1030
MAIA V. BRACCO
IPR PETITION

Kristina M. Wittstrom

Essentials of **NUCLEAR MEDICINE** **SCIENCE**

Edited by

William B. Hladik III, M.S., R.Ph.

Associate Professor of Pharmacy and Director of Radiopharmacy
College of Pharmacy
University of New Mexico
Albuquerque, New Mexico

Gopal B. Saha, Ph.D.

Staff Radiochemist
Department of Nuclear Medicine
The Cleveland Clinic Foundation
Cleveland, Ohio

Kenneth T. Study, B.S., C.N.M.T.

Medical Accounts Manager
Digital Equipment Corporation
Albuquerque, New Mexico

With the technical assistance of

Blair E. Friedman, M.A.

Senior Technical Sales Representative
Medi-Physics, Inc.
Lake Worth, Florida



WILLIAMS & WILKINS
Baltimore • London • Los Angeles • Sydney



Editor: John Butler
Associate Editor: Victoria M. Vaughn
Copy Editor: Bill Cady
Design: Bob Och
Illustration Planning: Lorraine Wrzosek
Production: Raymond E. Reter

Copyright © 1987
Williams & Wilkins
428 East Preston Street
Baltimore, MD 21202, U.S.A.



All rights reserved. This book is protected by copyright. No part of this book may be reproduced in any form or by any means, including photocopying, or utilized by any information storage and retrieval system without written permission from the copyright owner.

Accurate indications, adverse reactions, and dosage schedules for drugs are provided in this book, but it is possible that they may change. The reader is urged to review the package information data of the manufacturers of the medications mentioned.

Printed in the United States of America

Library of Congress Cataloging-in-Publication Data

Main entry under title:

Essentials of nuclear medicine science.

Includes bibliographies and index.

1. Radiopharmaceuticals. 2. Nuclear medicine. I. Hladik, William B., 1950- . II. Saha, Gopal B. III. Study, Kenneth T. [DNLM: 1. Nuclear Medicine. WN 440 E78]
RM 852.E87 1987 616.07'57 85-17978
ISBN 0-683-04051-0

Printed at the
Waverly Press, Inc.

87 88 89 90 91
10 9 8 7 6 5 4 3 2 1

To our wives:

Leslie
Sipra
Linda

and our children:

Billy and Anya
Prantik and Trina
Jessica

without whose love,
encouragement and patience
this project would
have never been completed

Foreword

Science in the service of the clinical practice of nuclear medicine often utilizes a variety of problem-solving techniques. The biodistribution of a radioactive tracer can provide significant physiologic, biochemical, and anatomic information regarding the health status of a patient. However, many parameters can influence the biodistribution of a radiotracer and confound the diagnostic information. In addition to the intrinsic biological factors that determine the basic distribution pattern, there are extrinsic factors (e.g., procedural errors, instrumentation errors, and adverse reactions) which can influence the presentation of the data and, thus, the ultimate outcome of the study. By knowing what these potential confounding factors are and how they operate, tough diagnostic questions can often be resolved.

When examining an individual study, we are often faced with the problem of differentiating what is unique from what is a repeated pattern. As more experience is gained, the once unique event becomes a known and repeated, but often rare, pattern. The sharing of information from various branches of nuclear medicine science is a powerful way to improve our skills in dealing with these day-to-day unusual patterns. In turn, the diagnostic potential of radiotracer studies is improved. The objective of collecting and organizing the information which helps us to recognize and understand the quirks of tracer biodistributions (and external variables which influence data capture) has been a major undertaking—an undertaking essential to the preparation of this volume. The various authors have done well to provide the reader with this collection of data and its synthesis into a basic reference.

The task which culminates with this book was started many years ago. In 1977, the faculty and staff of the University of New Mexico (UNM) Radiopharmacy realized that there was a critical need to teach radiopharmacy students the clinical side of their specialty practice more effectively. The effort to achieve a more clinically oriented teaching program required that data be collected from the various scientific specialists who serve on nuclear medical teams. As the information grew and was passed on to students and associates in the field, its value became increasingly apparent. This information has been shared via informal telephone exchange for a number of years. What the staff of the UNM Radiopharmacy was doing was also being done by other professionals at various nuclear medicine institutions. In time, it became more and more evident that there was a real need to compile the information that was being networked into a reference book. A number of authors have combined their efforts and information into a collection of manuscripts which will serve well those who are faced with the task of interpreting biodistribution studies—studies which may have been influenced by possible, and sometimes rare, confounding parameters.

Buck A. Rhodes, Ph.D.
Albuquerque, New Mexico

Preface

The nuclear medicine physician, in arriving at a diagnostic conclusion, uses multiple sources of information. Usually the data (images or numerical values) are evaluated, *de novo*, as the primary source of information to insure that the initial impressions are unbiased. Next, the ancillary information is obtained. This may include: (a) comments from the referring physician and other information regarding the patient, (b) procedural information supplied by the technology staff, (c) data from physicists, computer specialists, or other nuclear medicine scientists who may have had involvement in the procedure, and (d) pharmaceutical information from the staff responsible for preparing the radioactive tracer drugs. The physician's interpretation results from an integration of these primary and ancillary information sources plus knowledge gained from previous training and experience.

This book provides the reader with a wide scope of ancillary information on radiopharmaceuticals (and related subjects) that can be used to strengthen both the nuclear medicine clinical decision-making process as well as the radiopharmaceutical evaluation process. In general, chapter topics compensate for current deficiencies in the secondary literature relative to radiopharmaceuticals and other technological and biological parameters that must be taken into consideration by nuclear medicine professionals in their daily practice. The format of this book is such that physicians, pharmacists, technologists, and other scientists in the specialty area of nuclear medicine can utilize it as a textbook when they are students and then as a reference volume when they are carrying out their respective clinical functions.

It seems apparent that nuclear medicine, more than most other medical specialties, brings together quite a variety of scientists and professionals. Depending on the mix of scientists in a particular department, any one individual may take on a variable number of clinical responsibilities and thus must be familiar with a broad scope of topics beyond his or her specific area of expertise. Chapters in this book are intended to supply information which will assist nuclear medicine professionals with varied backgrounds and strengths to become more active and competent consultants in the clinical setting. Even with this in mind, this book is certainly not all-inclusive; rather, it touches on those areas about which the professional is frequently called upon to act as a source of information.

The use of the word "essentials" in the title of this book should not be construed to mean "basics." We assume that those who use this book will already be well trained in the *basic* concepts of their primary discipline related to nuclear medicine, i.e., health physics, technology, chemistry, pharmacy, medicine, etc., and thus there is no need to include such information in this book. However, all of the material herein is *essential* if the individual is to communicate effectively and serve as a source of current and relevant information.

The stimulus for the development of this book was primarily forthcoming from inquiries directed to the University of New Mexico (UNM) Radiopharmacy. The UNM group has operated a consultation service for local, state, and national callers seeking answers to

questions or problems that they are encountering in nuclear medicine, particularly specific and detailed information pertaining to physical, pharmacologic, physiologic, pharmacokinetic, or quality control parameters which influence the in vivo performance of radioactive tracers. This has provided us with the opportunity to collect and organize the data into a bank of readily retrievable information, which served as the nucleus for the book.

Authors of each chapter were selected on the basis of their individual expertise in the particular area. Chapters have been written with as much up-to-date information as possible and are adequately referenced. Because each chapter is written by different authors on related matter, there is some inadvertent overlap of contents in different chapters despite our careful editing. Due to the rapid pace of nuclear medicine growth and the long process of editing and publishing, certain recently released information could not be included in the book.

William B. Hladik III
Gopal B. Saha
Kenneth T. Study

Acknowledgments

The editors would like to thank particularly Buck A. Rhodes, Ph.D., who suggested the need for this type of book and helped to develop its "character." His foresight and inspiration are deeply appreciated.

We are indebted to Blair E. Friedman, M.A., who was instrumental in contacting potential authors, making arrangements with the publisher, and proofreading the typeset copy.

We would also like to acknowledge Kay L. Hicks, Elva G. Giron, Sharon I. Ramirez, and Jennifer A. Farenbaugh for their superb secretarial assistance.

For her photography expertise, we acknowledge and thank Chris Martín, Albuquerque, New Mexico, who supplied the image ultimately selected for the book cover.

Our sincerest thanks go to Zophia Pastuszyn, C.N.M.T., Ruth Snyder, and the entire staff in the nuclear medicine department at Lovelace Medical Center, for providing scintiscans considered for the book cover.

Special credit is extended to the staff of Williams & Wilkins for their advice and patience during the development and production of this book.

We gratefully acknowledge Carman A. Bliss, Dean of the College of Pharmacy, University of New Mexico, and the management of Digital Equipment Corporation for their support of this task.

Finally, the editors extend their deepest appreciation to the contributors who have cooperated fully in all aspects of the preparation of this text.

Contributors

Neil Abel, M.S., M.B.A.
Reviewing Pharmacist
Food and Drug Administration
Rockville, Maryland

Harold L. Atkins, M.D.
Professor of Radiology
School of Medicine
Health Sciences Center
State University of New York at Stony Brook
Stony Brook, New York
and
Chief, Division of Nuclear Medicine
Department of Radiology
University Hospital at Stony Brook
Stony Brook, New York

William J. Baker, M.S.
Associate Professor of Nuclear Pharmacy and
Director, Intermountain Radiopharmacy
College of Pharmacy
University of Utah Health Sciences Center
Salt Lake City, Utah

Robert W. Beightol, Pharm.D., B.C.N.P.
Director, Nuclear Pharmacy Services
Roanoke Memorial Hospitals
Roanoke, Virginia

Ralph Blumhardt, M.D.
Associate Professor of Radiology and
Head of Division of Nuclear Medicine
University of Texas Health Science Center at San
Antonio
San Antonio, Texas

Terry L. Braun, B.S., R.Ph.
Radiochemist
Cancer Therapy Institute
King Faisal Specialist Hospital
Riyadh, Saudi Arabia

Donald A. Bille, Ph.D., R.N.
Nursing School Professor
Graduate Faculty
Graduate Department of Nursing Education,
Administration, and Health Policy
School of Nursing
University of Maryland
Baltimore, Maryland

Doyle W. Cantrell, B.A., R.T.(N), C.N.M.T.
Director of Medical Imaging
Park Lane Medical Center
Kansas City, Missouri

Teresa J. Cantrell, B.A., R.T.(N), C.N.M.T.
Supervisor of Nuclear Medicine/Ultrasound
Department of Radiology
St. Lukes Hospital
Kansas City, Missouri

Henry M. Chilton, Pharm.D.
Associate Professor
Division of Nuclear Medicine
Department of Radiology
Bowman Gray School of Medicine
Wake Forest University
Winston-Salem, North Carolina

Jeffrey A. Clanton, M.S., B.C.N.P.
Associate in Radiology and
Chief of Radiopharmacy Services
Vanderbilt University Medical Center
Nashville, Tennessee

Jack L. Coffey, M.S., C.H.P.
Health Physicist
Synacor International Corporation
Albuquerque, New Mexico

Larry T. Cook, Ph.D.
Associate Professor of Diagnostic Radiology
Division of Diagnostic Imaging and Radiological
Science
Department of Diagnostic Radiology
University of Kansas Medical Center
Kansas City, Kansas

M. Annette Cordova, M.S., R.Ph.

Assistant Director
Department of Pharmacy
Northeast Community Hospital
Bedford, Texas

John J. Coupal, Ph.D.

Assistant Clinical Professor of Radiation Medicine
College of Medicine
University of Kentucky
Lexington, Kentucky

and
Nuclear Pharmacist
Nuclear Medicine Service
Veterans Administration Medical Center
Lexington, Kentucky

Robert J. Cowan, M.D.

Professor of Radiology
Division of Nuclear Medicine
Department of Radiology
Bowman Gray School of Medicine
Wake Forest University
Winston-Salem, North Carolina

Frederick L. Datz, M.D.

Associate Professor of Radiology and
Clinical Director of Nuclear Medicine
School of Medicine
University of Utah Health Sciences Center
Salt Lake City, Utah

Natalie Foster, Ph.D.

Assistant Professor
Department of Chemistry
Center for Health Sciences
Lehigh University
Bethlehem, Pennsylvania
and
Adjunct Assistant Professor
Department of Radiation Oncology and Nuclear
Medicine
Hahnemann University
Philadelphia, Pennsylvania

John E. Freitas, M.D.

Nuclear Medicine Department
William Beaumont Hospital
Royal Oak, Michigan
and
Clinical Associate Professor
University of Michigan Medical School
Ann Arbor, Michigan
and
Clinical Associate Professor
School of Medicine
Wayne State University
Detroit, Michigan

Allan H. Gobuty, Pharm.D., M.S.

Assistant Professor of Radiology
Medical School
University of Texas Health Science Center at
Houston
Houston, Texas
and
Director, Nuclear Pharmacy Services
Hermann Hospital
Houston, Texas

Ned Gregorio, R.Ph., B.C.N.P.

Nuclear Pharmacist
Radiopharmacy
College of Pharmacy
University of New Mexico
Albuquerque, New Mexico

Ned D. Heindel, Ph.D.

Professor, Department of Chemistry and
Director, Center for Health Sciences
Lehigh University
Bethlehem, Pennsylvania
and
Adjunct Professor
Department of Radiation Oncology and Nuclear
Medicine
Hahnemann University
Philadelphia, Pennsylvania

William B. Hladik III, M.S., R.Ph.

Associate Professor of Pharmacy and
Director of Radiopharmacy
College of Pharmacy
University of New Mexico
Albuquerque, New Mexico

Robert Hodges, Pharm.D.

Staff Pharmacist
Washington Regional Medical Center
Fayetteville, Arkansas

Karl F. Hubner, M.D.

Professor of Radiology and
Director of Research
Department of Radiology
University of Tennessee Hospital
Knoxville, Tennessee

Robert C. Jost, M.S., R.Ph.

Pharmacist
University of New Mexico Hospital
Albuquerque, New Mexico

E. Edmund Kim, M.D., M.S.

Professor of Radiology and Medicine, and
Director, Division of Nuclear Medicine
University of Texas Health Science Center at
Houston
Houston, Texas

Jack L. Lancaster, Ph.D.

Assistant Professor of Radiology and
Head of Diagnostic Radiology Physics Section
University of Texas Health Science Center at San
Antonio
San Antonio, Texas

John C. Lasher, M.D.

Assistant Professor of Radiology
University of Texas Health Science Center at San
Antonio
San Antonio, Texas

David L. Laven, C.R.Ph. F.A.S.C.P.

Director, Nuclear Pharmacy Service
Nuclear Medicine Department
Veterans Administration Medical Center
Bay Pines, Florida

Brian C. Lentle, M.D., F.R.C.P.(C)

Director, Department of Nuclear Medicine
Vancouver General Hospital
Vancouver, British Columbia
and
Head, Division of Nuclear Medicine
Department of Radiology
University of British Columbia
Vancouver, British Columbia

Geoffrey Levine, Ph.D., B.C.N.P.

Associate Professor of Radiology
School of Medicine
University of Pittsburgh
Pittsburgh, Pennsylvania
and
Clinical Associate Professor of Pharmaceutical
Sciences
School of Pharmacy
University of Pittsburgh
Pittsburgh, Pennsylvania
and
Director of Nuclear Pharmacy
Presbyterian-University Hospital
Pittsburgh, Pennsylvania

Zvi H. Oster, M.D.

Professor of Radiology
School of Medicine
Health Sciences Center
State University of New York at Stony Brook
Stony Brook, New York
and
Co-Chief, Division of Nuclear Medicine
Department of Radiology
University Hospital at Stony Brook
Stony Brook, New York
and
Research Collaborator and
Visiting Clinician
Medical Department

Brookhaven National Laboratory
Upton, New York

James A. Ponto, M.S., R.Ph., B.C.N.P.

Nuclear Pharmacist
Department of Radiology
University of Iowa Hospitals and Clinics
Iowa City, Iowa
and
Clinical Associate Professor
College of Pharmacy
University of Iowa
Iowa City, Iowa

David F. Preston, M.D.

Professor of Diagnostic Radiology
Division of Nuclear Medicine
Department of Diagnostic Radiology
University of Kansas Medical Center
Kansas City, Kansas

Buck A. Rhodes, Ph.D.

President
RhoMed, Inc.
Albuquerque, New Mexico

Gopal B. Saha, Ph.D.

Staff Radiochemist
Department of Nuclear Medicine
The Cleveland Clinic Foundation
Cleveland, Ohio

Prantika Som, D.V.M., Sc.M.

Scientist
Brookhaven National Laboratory
Upton, New York
and
Research Associate Professor of Radiology
School of Medicine
Health Sciences Center
State University of New York at Stony Brook
Stony Brook, New York

Michael G. Stabin, M.E.

Radiopharmaceutical Internal Dose Information
Center
Manpower Education, Research and Training
Division
Oak Ridge Associated Universities
Oak Ridge, Tennessee

Victor J. Stathis, B.S., R.Ph.

Nuclear Pharmacist
Pharmacy Department
N. T. Enloe Memorial Hospital
Chico, California

Kenneth T. Study, B.S., C.N.M.T.

Medical Accounts Manager
Digital Equipment Corporation
Albuquerque, New Mexico

Colin B. Styles, M.D.
 Department of Nuclear Medicine
 St. Vincent's Hospital
 Victoria Parade
 Fitzroy 3065, Australia

Dennis P. Swanson, M.S., R.Ph., B.C.N.P.
 Department of Diagnostic Radiology and Medical
 Imaging
 Henry Ford Hospital
 Detroit, Michigan
 and
 Clinical Associate Professor of Pharmacy
 College of Pharmacy
 University of Michigan
 Ann Arbor, Michigan
 and
 Adjunct Associate Professor of Pharmacy Practice
 School of Pharmacy
 Wayne State University
 Detroit, Michigan

Roger W. Taft, B.S., C.N.M.T.
 Section Supervisor
 Division of Nuclear Medicine
 Department of Radiology
 Heights General Hospital
 Albuquerque, New Mexico

James F. Vandergrift, M.S.
 Assistant Professor of Radiology (Physics) and
 Radiation Safety Officer
 College of Medicine
 University of Arkansas for Medical Sciences
 Little Rock, Arkansas

Evelyn E. Watson
 Program Manager
 Radiopharmaceutical Internal Dose Information
 Center
 Manpower Education, Research and Training
 Division
 Oak Ridge Associated Universities
 Oak Ridge, Tennessee

Contents

Foreword	vii
Preface	ix
Acknowledgments	xi
Contributors	xiii

I Considerations for the Clinical Use of Radiopharmaceuticals

Chapter 1 Normal Biodistribution of Diagnostic Radiopharmaceuticals <i>Gopal B. Saha</i>	3
Chapter 2 Radiopharmacokinetics in Nuclear Medicine <i>Jeffrey A. Clanton</i>	20
Chapter 3 Biodistribution and Structure in Radiodiagnostics <i>Ned D. Heindel and Natalie Foster</i>	33
Chapter 4 Metabolic Fate of Radiopharmaceuticals <i>Robert C. Jost</i>	44
Chapter 5 Radiopharmaceutical Absorbed Dose Considerations <i>Jack L. Coffey, Evelyn E. Watson, Karl F. Hubner, and Michael G. Stabin</i>	51
Chapter 6 Considerations and Controversies in the Selection of Radiopharmaceuticals <i>Henry M. Chilton and Robert J. Cowan</i>	75
Chapter 7 Therapeutic Applications of Radiopharmaceuticals <i>William J. Baker, Frederick L. Datz, and Robert W. Beightol</i>	84
Chapter 8 Preparation and Clinical Utility of Labeled Blood Products <i>William J. Baker and Frederick L. Datz</i>	90
Chapter 9 Nuclear Medicine Procedures for Monitoring Patient Therapy <i>Allan H. Gobuty</i>	99

Chapter 10	
Interventional Studies in Nuclear Medicine	
<i>Gopal B. Saha, Dennis P. Swanson, and William B. Hladik III</i>	115
Chapter 11	
Medical Decision Making	
<i>David F. Preston and Larry T. Cook</i>	133
Chapter 12	
Computer Applications in Nuclear Medicine	
<i>Jack L. Lancaster, John C. Lasher, and Ralph Blumhardt</i>	145

II

Problems and Pitfalls Encountered with the Use of Radiopharmaceuticals

Chapter 13	
Iatrogenic Alterations in the Biodistribution of Radiotracers as a Result of Drug Therapy: Theoretical Considerations	
<i>Robert Hodges</i>	165
Chapter 14	
Iatrogenic Alterations in the Biodistribution of Radiotracers as a Result of Drug Therapy: Reported Instances	
<i>William B. Hladik III, James A. Ponto, Brian C. Lentle, and David L. Laven</i>	189
Chapter 15	
Iatrogenic Alterations in the Biodistribution of Radiotracers as a Result of Radiation Therapy, Surgery, and Other Invasive Medical Procedures	
<i>Brian C. Lentle and Colin B. Styles</i>	220
Chapter 16	
Normal Clinical Variation in Anatomic Structure and Physiologic Function and Its Effect on Radiopharmaceutical Biodistribution	
<i>John J. Coupal and E. Edmund Kim</i>	234
Chapter 17	
Unusual or Unanticipated Alterations in the Biodistribution of Radiopharmaceuticals as a Result of Pathologic Mechanisms	
<i>E. Edmund Kim and John J. Coupal</i>	248
Chapter 18	
Clinical Manifestations of Radiopharmaceutical Formulation Problems	
<i>James A. Ponto, Dennis P. Swanson, and John E. Freitas</i>	268
Chapter 19	
Instrumentation and Procedural Problems in Nuclear Medicine	
<i>Kenneth T. Study and Roger W. Taft</i>	290
Chapter 20	
Adverse Reactions Associated with Radiopharmaceuticals	
<i>M. Annette Cordova, William B. Hladik III, Buck A. Rhodes, and Harold L. Atkins</i>	303

Chapter 21	
Regulatory Problems in Nuclear Medicine	
<i>James F. Vandergrift</i>	321

III

Considerations for the Preclinical and the Clinical Investigation of New Radiopharmaceuticals

Chapter 22	
Animal Models of Human Disease	
<i>Prantika Som and Zvi H. Oster</i>	333
Chapter 23	
Considerations in the Assembly and Submission of the Physician-sponsored Investigational New Drug Application	
<i>Geoffrey Levine and Neil Abel</i>	357

IV

Interactions among Nuclear Medicine Health Care Professionals and Patients

Chapter 24	
Radiopharmaceutical Information and Consultation Services	
<i>William B. Hladik III, Ned Gregorio, Terry L. Braun, Victor J. Stathis, and James A. Ponto</i>	389
Chapter 25	
Issues of Patient Education	
<i>Donald A. Bille</i>	404
Chapter 26	
Patient Preparation for Nuclear Medicine Studies	
<i>Victor J. Stathis, Doyle W. Cantrell, and Teresa J. Cantrell</i>	411
Index	421

*Considerations
for the Clinical Use of
Radiopharmaceuticals*

1

Normal Biodistribution of Diagnostic Radiopharmaceuticals

Gopal B. Saha

Nuclear medicine as a diagnostic modality has grown to such an extent that it is practiced in almost all hospitals nationwide. In the practice of nuclear medicine, physicians set norms for morphology or physiologic function of each organ by studying a large number of normal patients. For every procedure, there is in these diagnostic data a range of normal variations that are familiar to the physicians. Nuclear medicine practitioners interpret diseases or pathologies that are attributed on the basis of the deviations from the limits of these variations.

As indicated in the Preface, this book primarily focuses on ancillary information in the interpretation of nuclear medicine studies. Before learning about abnormalities along with various pitfalls and artifacts in a nuclear medicine study, however, one ought to be familiar with the normal biodistribution of different radiopharmaceuticals. This chapter highlights the expected normal biodistributions of various routinely used radiopharmaceuticals. Detailed pharmacokinetic and metabolic aspects of radiopharmaceuticals have not been presented, as they are discussed in the following chapters. In a few instances, scintiphotos illustrating normal biodistribution have been included. Familiarity with the material in this chapter should provide better understanding and appreciation of the contents of later chapters.

SODIUM [^{99m}Tc]PERTECHNETATE

^{99m}Tc decays with a half-life of 6 hours and emits γ -rays of 140 keV with an abundance of 90%. This radionuclide is obtained in the chemical form of NaTcO₄ by eluting the ⁹⁹Mo-^{99m}Tc

generators with isotonic saline. Sodium [^{99m}Tc]pertechnetate and many ^{99m}Tc products account for almost 80% of the radiopharmaceuticals used in nuclear medicine procedures. The reason for such a preeminent position for ^{99m}Tc is that its electron emission is negligible and thus the radiation dose to patients is minimal. The γ -ray energy of 140 keV is suitable for scintigraphy with a gamma camera.

After intravenous administration, ^{99m}Tc-pertechnetate* initially distributes itself in the vascular compartment. Radiopertechnetate most closely resembles iodide in biologic behavior and becomes plasma protein bound, mostly to albumin (1). Plasma clearance is very rapid, and equilibrium between vascular compartment and interstitial fluid is achieved in as short a time as 2 to 3 minutes. The plasma clearance half-time is approximately 30 minutes. Approximately 30% of the administered dose is excreted in the first 24 hours. The total urinary and fecal excretion of ^{99m}Tc activity is about 50% in 3 days and almost 70% in 8 days. Beasley et al. (2) observed that pertechnetate is secreted by the salivary glands and gastric mucosa and is excreted to a significant degree in the feces. The distribution of pertechnetate is somewhat different from iodide distribution in that iodide is reabsorbed once it passes into the small intestine. Also, about 1% of the administered dose of pertechnetate is trapped by the thyroid glands.

*Although [^{99m}Tc]pertechnetate is preferred by IUPAC, ^{99m}Tc-pertechnetate is standard, and both are used throughout this chapter.

The administered dose varies with the type of study: 10–20 mCi for brain imaging, 1–5 mCi for thyroid studies, and 20–25 mCi for *in vivo* red blood cell labeling for gated blood pool studies. In brain and thyroid studies, imaging is performed about 20–30 minutes or longer after injection, whereas in gated blood pool studies, it is performed 5–10 minutes after injection.

Brain imaging with $^{99m}\text{TcO}_4^-$ is governed by the blood-brain barrier (BBB) which prevents $^{99m}\text{TcO}_4^-$ from entering normal brain cells. The BBB breaks down, however, in abnormal cells such as occur in tumors, infarcts, and other conditions, and thus the tracer localizes in lesions. $^{99m}\text{TcO}_4^-$ localizes in the choroid plexus, and thus artifacts are seen in normal brain images; this is prevented by oral administration of 250 mg potassium perchlorate to patients just prior to injection of the tracer (3). Potassium perchlorate saturates the choroid plexus and leaves no binding sites for $^{99m}\text{TcO}_4^-$.

The normal brain scintigraphs do not show activity within the cerebrum itself due to the blood-brain barrier. The periphery of the hemispheres, however, is outlined by increased activity in the subarachnoid space, calvaria, and soft tissues of the scalp. Increased activity is also seen in the sagittal and transverse sinuses. On the posterior views, the transverse sinuses are generally symmetric. On lateral views, activity is seen in the suprasellar and sylvian regions.



Figure 1.1. A normal thyroid scintigraph obtained at 60 minutes after administration of 5 mCi of $^{99m}\text{TcO}_4^-$.

$^{99m}\text{TcO}_4^-$ is trapped in the thyroid but, unlike iodide, is not organified. Administration of perchlorate, Lugol's solution, and thiocyanate reduces the ^{99m}Tc uptake by the thyroid glands. Normal thyroid uptake of $^{99m}\text{TcO}_4^-$ is only 0.3–3.0% at 20 minutes after administration. A normal scintigraph exhibits a homogeneous distribution of radioactivity in both thyroid lobes which have a butterfly or a wide "V" appearance. The size of the isthmus varies from thin and barely visible, to wide with an intense image. The pyramidal lobe can be visualized in a small percentage of normal scans. A normal thyroid scintigraph obtained with $^{99m}\text{TcO}_4^-$ is shown in Figure 1.1.

^{99m}Tc - DIETHYLENTRIAMINEPENTAACETIC ACID

^{99m}Tc -diethylenetriaminopentaacetic acid (DTPA) is primarily used for brain and renal imaging and for measurement of glomerular filtration rate (GFR). After intravenous injection, it is excreted entirely by glomerular filtration. Hauser et al. (4) and Atkins et al. (5) have studied the pharmacokinetic characteristics of this radiopharmaceutical in dogs and humans. The plasma disappearance curve consists of three components with $t_{1/2}$ s of 12 minutes, 98 minutes, and 14.8 hours. The protein binding is approximately 5–10% at 1 hour. Maximum renal uptake (5%) occurs 5 minutes after administration. Urinary excretion is about 90% in 24 hours.

Because DTPA is entirely filtered by glomeruli, GFR can be determined by use of this radiopharmaceutical (6, 7). Plasma protein binding of DTPA yields somewhat erroneous GFR values, however. ^{99m}Tc -DTPA also is used for renal imaging. Because of this radiopharmaceutical's rapid elimination by filtration, early images of the kidney allow good demonstration of the parenchyma primarily due to blood supply in the kidneys (8).

Brain imaging with ^{99m}Tc -DTPA has been successfully accomplished by many investigators and is now accepted as a routine procedure. The mechanism of localization is governed by the blood-brain barrier, as is $^{99m}\text{TcO}_4^-$ uptake in the brain. DTPA does not accumulate in the

choroid plexus and, thus, has an advantage over $^{99m}\text{TcO}_4^-$ as a brain imaging agent.

^{99m}Tc -GLUCEPTATE

^{99m}Tc -gluceptate (GH)[†] is used for brain and renal imaging. After intravenous administration, it is excreted by both glomerular filtration and tubular secretion. A comparative study of ^{99m}Tc -labeled GH, DTPA, and dimercaptosuccinic acid (DMSA) has been made by Arnold et al. (8). Its plasma clearance is very rapid for the first 2 hours and becomes slower thereafter. The ^{99m}Tc -GH is loosely bound to proteins initially and increases in binding to about 75% after 6 hours. Approximately 12% of the administered dose accumulates in the kidney, largely in the cortex. Urinary excretion is nearly 50% in 2 hours and 70% in 24 hours. The brain and renal scintigraphs show a distribution of activity similar to that of DTPA. Like DTPA, GH does not accumulate in the choroid plexus.

^{99m}Tc -LABELED MACROAGGREGATED ALBUMIN OR ALBUMIN MICROSPHERES

^{99m}Tc -labeled macroaggregated albumin (MAA) or albumin microspheres commonly are used for lung perfusion imaging. The particles are about 10–90 μm in size, and in a dose of 3–4 mCi, approximately 100,000–500,000 particles are administered per injection. The particles are lodged in capillaries and precapillary arteries during the first transit of blood circulation through the lungs. Larger particles (>150 μm) should not be administered because they may occlude precapillary arteries and cause regional pulmonary embolism.

The clearance of particles from the lungs depends on the size and number of particles administered. Approximately 50% of 50–100 million MAA particles in the 10–70- μm range is cleared from human lungs in about 4–6 hours (9, 10). Albumin microspheres are cleared more slowly than are MAA particles, because they are more rigid and their clearance is slower (of the order of 12–24 hours) (11). Mechanical move-

ment and certain enzymatic action in the lungs break down the aggregated particles into smaller ones which are then removed by the reticuloendothelial system (RES) (12, 13). Some radioactivity is excreted by the kidney, and urinary excretion is about 42–46% in 48 hours (14).

In normal lung scintigraphs, labeled particles are evenly distributed in anterior and posterior projections. Somewhat less activity is seen in the upper zones due to less lung volume. The well-defined defect due to the heart is seen on anterior and lateral views. The lungs look relatively smaller in obese patients. Minor variations in the distribution of particles, due to slight abnormalities in the pattern of blood flow, particularly in the right lung, are observed in about 20–25% of apparently healthy subjects (15). Perfusion defects also are seen in elderly subjects, which is perhaps related to undetected obstructive airway diseases (16, 17). The position of the patient also affects the distribution pattern of MAA particles. If patients in an upright position are given injections, particles settle at the bottom of the lungs and less activity is seen in the upper part of the lungs. Normal lung scintigraphs are shown in Figure 1.2.

^{99m}Tc -LABELED COLLOIDS

^{99m}Tc -labeled sulfur colloid is the most commonly used radiolabeled colloid in nuclear medicine. The size of these particles varies between 50 nm and 500 nm, with a mean of ~150 nm, and they are removed by the RES (liver, spleen, and bone marrow).

After intravenous injection, about 80–85% of the dose accumulates in the liver; 10%, in the spleen; and the rest, in the bone marrow. Various factors such as hepatic blood flow, RES integrity, the size and the number of particles, and the physical characteristics of particles affect the *in vivo* distribution of the colloid (18, 19). The particles are lodged permanently in the reticuloendothelial cells and the effective half-life is almost equal to the physical half-life of ^{99m}Tc . The plasma clearance half-time is about 2–5 minutes, and the maximum liver uptake occurs within 10–15 minutes. The clearance rate of colloid particles depends on the blood volume perfusing the liver and on the number of particles. As the number of particles increases,

[†] Gluceptate is the official (USAN) name for what was previously known as glucoheptonate; the commonly used abbreviation "GH" comes from this latter term.

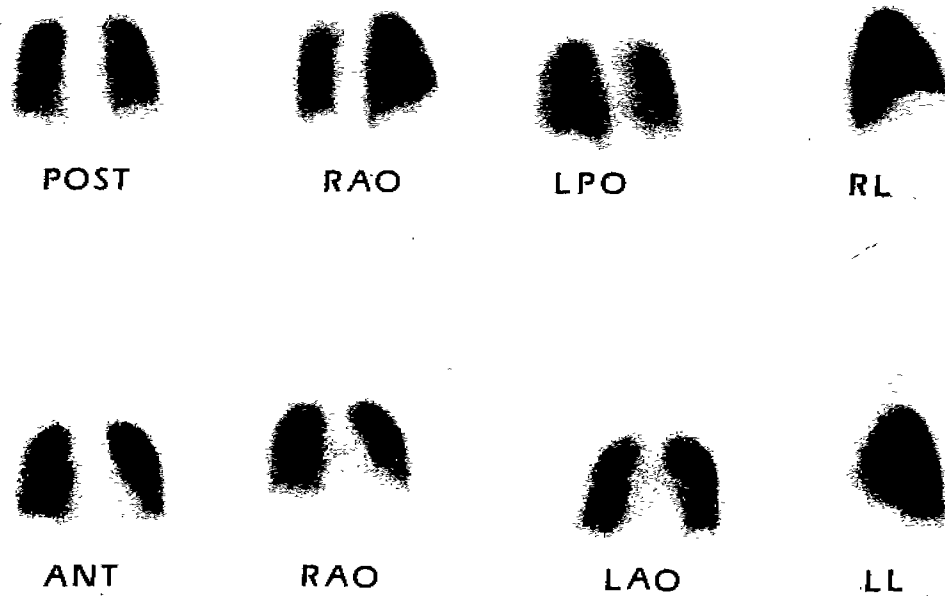

Figure 1.2. Normal lung scintigraphs obtained in different projections after administration of 4 mCi of ^{99m}Tc -MAA. *POST*, posterior; *RAO*, right anterior oblique; *LPO*, left posterior oblique; *RL*, right lateral; *ANT*, anterior; *LAO*, left anterior oblique; *LL*, left lateral.

the clearance rate falls, reaching minimum values with progressive saturation of the phagocytic capacity. In normal adults, the maximum clearance in each passage is about 94% (20).

In normal subjects, there are wide variations in the distribution of radioactive colloids due to various contours of the liver and spleen. In decreased hepatocellular function, the colloid uptake is shifted toward the spleen and bone marrow. Often, the uptake at the junction of the right and left lobes is diffuse due to the thinness of the connective tissues. The density of spleen activity usually is the same as or somewhat less than that of right posterior activity. The most commonly encountered artifact is due to the scatter of 140 keV γ -rays of ^{99m}Tc in overlying structures, such as female breasts. Another common finding is the lung uptake of colloids. This uptake has been attributed to phagocytosis by macrophages in the lungs (21) or by RES cells migrated into the lungs under the influence

of estrogen, endotoxin, heparin, and perhaps other substances (22). Normal liver scintigraphs obtained with use of 3 mCi of ^{99m}Tc -labeled sulfur colloid are shown in Figure 1.3.

Another colloid of importance is ^{99m}Tc -labeled antimony sulfide colloid which is commonly used for lymphoscintigraphy. The particle size of this colloid ranges between 10 nm and 20 nm. Subcutaneous injections are made between the first and second metatarsals for imaging of lymphatic flow in the legs, between the first and second metacarpals for imaging of the arms, and at both sides of the xyphoid process for imaging of the parasternal nodes. Approximately 80% of the colloid is transported by the lymphatic system. At 24 hours after and depending on the site of injection, the inguinal, iliac, and periaortic regions, several lymph nodes in the parasternal region, and other lymph nodes are seen. Discontinuity in the flow of radioactivity may result from metastasis; increased activity in any area may be due to lymphoma or partial blockade of the lymphatics. In parasternal lymph node scintigraphy, 96% reproducibility was obtained by Ege (23).

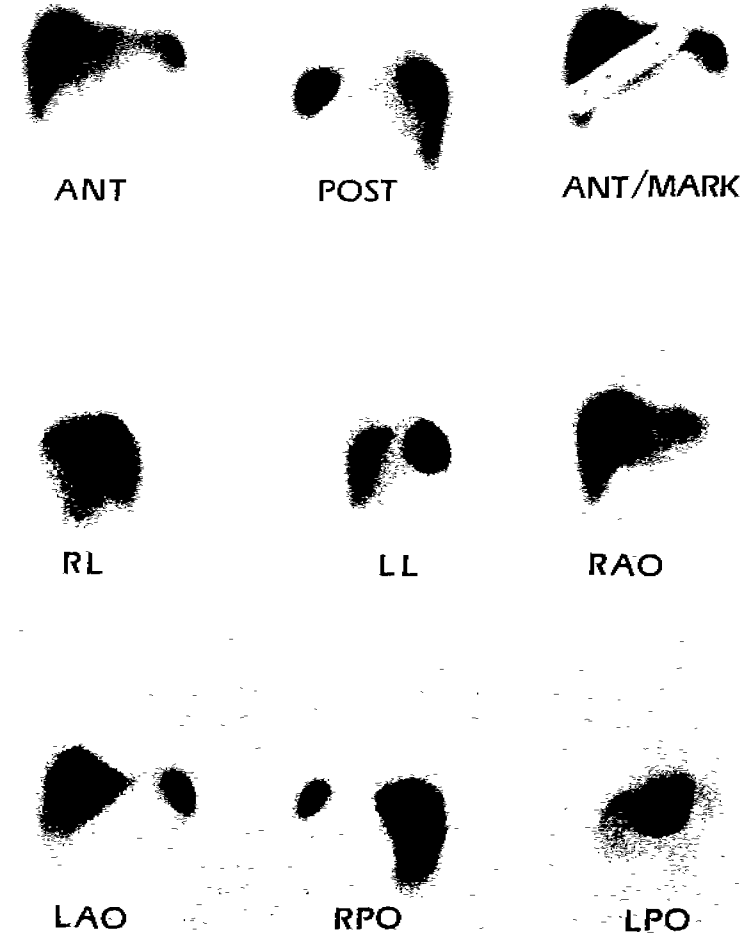

Figure 1.3. Normal liver scintigraphs obtained in different projections after administration of 3 mCi of ^{99m}Tc -labeled sulfur colloid. *ANT*, anterior; *POST*, posterior; *ANT/MARK*, anterior/marker; *RL*, right lateral; *LL*, left lateral; *RAO*, right anterior oblique; *LAO*, left anterior oblique; *RPO*, right posterior oblique; *LPO*, left posterior oblique.

^{99m}Tc -LABELED PHOSPHATE COMPOUNDS

Several ^{99m}Tc -labeled phosphate complexes have been investigated for bone imaging; currently, however, only ^{99m}Tc -labeled methylene diphosphonate (MDP) and ^{99m}Tc -labeled hy-

droxymethylene diphosphonate (HDP) are commonly used for this purpose. Approximately 20 mCi of ^{99m}Tc -MDP or ^{99m}Tc -HDP are administered intravenously to the patient, and scintigraphic images are obtained 2–3 hours after injection. Immediately prior to imaging, the patient should void in order to reduce the background from the bladder activity.

A comparative study of four phosphate compounds (^{99m}Tc -labeled polyphosphate, pyro-

phosphate (PYP), hydroxyethylidene diphosphonate (HEDP), and MDP) has been made by Subramanian et al. (24). At 2 hours after administration to rabbits, the bone uptake of both HEDP and MDP is about 7–9% of the administered dose per 1% of total body weight, but the absolute bone concentration was significantly higher for both diphosphonates than for PYP. In humans, the blood clearance of HEDP is somewhat slower than that of MDP for the first 6 hours, but at 24 hr the blood level of HEDP is slightly lower than that of MDP. The blood clearance was much slower for PYP than for either diphosphonate. The 24-hour urinary excretion of HEDP and MDP is about 75–80%, while that of PYP is about 60%. Protein-binding of MDP and PYP has been reported to be approximately 22% (25) and 42% (26), respectively, 2 hours after injection. The protein-binding of HEDP is about 30% at 3 hours (24).

Recently, ^{99m}Tc -HDP has been introduced and shown to have better bone localization than does MDP (27, 28). Rib uptake values of HDP and MDP in dog are 5.4% and 4.3%, respectively, of the administered dose per 1 gm of body weight. Urinary excretion in dog is about 59% in 24 hours. The relatively low urinary excretion of HDP compared with MDP, however, is primarily due to skeletal uptake rather than to protein binding. A comparative study of whole-body retention reflecting skeletal uptake of three diphosphonates (HEDP, MDP, and HDP) has been made in humans by Fogelman et al. (29). This study has shown that the whole-body retention of these three compounds is 18.4%, 30.3%, and 36.6%, respectively, which indicates greater uptake for HDP. Clinical studies also have proved this material to be somewhat superior to MDP.

Increased blood flow, reactive bone formation, and extraction efficiency of the bone mineral are the determining factors for bone uptake of ^{99m}Tc -labeled phosphate complexes. Uptake is higher in the growing skeleton of children than in the skeleton of adults. Bone uptake decreases with increasing age. Symmetric areas of increased concentration are seen in the metaphyseal zones in the growing skeleton. Ankles, knees, elbows, wrists, shoulder joints, pelvic bones, and vertebrae are all seen with increased

uptake. Approximately 2–4% of the injected dose accumulates in the normal kidneys, although the isotope may localize in normal breasts, soft tissues, tumors, and sites of inflammation and injection. Normal anterior skeletal scintigraphs obtained with ^{99m}Tc -HDP are shown in Figure 1.4.

Willerson et al. (30) has shown that ^{99m}Tc -PYP accumulates in myocardial infarct to such an extent that meaningful imaging could be made of the infarcts. It has also been shown that there is reasonable accumulation of ^{99m}Tc -HDP in myocardial infarcts (28). In the canine, the uptake values of ^{99m}Tc -HDP and ^{99m}Tc -PYP are 5.1% and 4.4%, respectively, of the administered dose per 1 gm of body weight in infarcted myocardium, compared with 0.15% and 0.13% in normal myocardium.

^{99m}Tc -LABELED IMINODIACETIC ACID DERIVATIVES

Iminodiacetic acid (IDA) derivatives labeled with ^{99m}Tc are routinely used for evaluation of hepatocytic function. Loberg et al. (31) first introduced a ^{99m}Tc -labeled derivative of IDA for this purpose. Wistow et al. (32) developed and evaluated such IDA derivatives as 2,6-diethyl, *p*-ethoxy, and *p*-iodo-IDA and found that all had excellent hepatobiliary specificity and differed primarily in blood clearance and urinary excretion. Newer derivatives are *p*-isopropyl (PIPIDA) and diisopropyl-substituted iminodiacetic acid (DISIDA) that have been shown to have better hepatobiliary characteristics.

Approximately 3–5 mCi of a ^{99m}Tc -labeled IDA derivative is injected intravenously into humans who have fasted for 2–4 hr, and imaging is performed at different time intervals up to 1–4 hours, which indicates liver function and biliary patency. The liver activity is seen within a few minutes, is cleared rapidly, and appears in the gallbladder and then in the intestine. In dogs, the blood clearance half-time of ^{99m}Tc -HIDA is only a few minutes, with only 3% of the injected dose remaining in the blood at 30 minutes, and cumulative urinary excretion is about 17% of the administered dose at 2 hours after administration. The hepatobiliary system is visible with a bilirubin level as high as 5–8 mg/dl. The gallbladder could be seen within 30



ANTERIOR BONE IMAGES

Figure 1.4. Normal anterior skeletal scintigraphs obtained as spot views after administration of 20 mCi ^{99m}Tc -HDP.

minutes after administration (33, 34). As hepatocellular function decreases and bilirubin level progressively increases, hepatobiliary excretion decreases and renal excretion increases.

Lengthening the alkyl chain on the benzene ring of the IDA molecule results in increased hepatobiliary excretion and reduced urinary excretion. PIPIDA behaves similarly to HIDA, except that it gives slightly better visualization of the biliary system when the bilirubin level is 20–25 mg/dl (35). The common bile duct is not well visualized by PIPIDA, however. Its urinary excretion in rabbits is about 7.5% of the dose 30 minutes after administration (36). ^{99m}Tc -labeled butyl iminodiacetic acid (BIDA) has somewhat slower plasma clearance and liver uptake and much less renal clearance than has PIPIDA (37). Urinary excretion is of the order of 0.7% of the injected dose 30 minutes after administration (36). It is useful when the bilirubin level is 10–20 mg/dl (35).

^{99m}Tc -diethyl-IDA has proved to be very useful as a hepatobiliary agent (38–40). In rabbits, its blood content is about 1.2%, and urinary excretion is 9.0% of the administered dose 30 minutes after administration (35). The subsequent development of DISIDA derivatives, however, has added significantly to hepatobiliary imaging, and currently it is the agent of choice for this purpose. Thirty minutes after intravenous administration, nearly 8% of the dose remains in the circulation. Approximately 9% is excreted in the urine in the first 2 hours after injection. In fasting individuals, maximum liver uptake occurs by 10 minutes, and peak gallbladder activity, by 30–40 minutes after injection (41). ^{99m}Tc -DISIDA provides superior images when the bilirubin level is 20–30 mg/dl.

In normal scintigraphs, the liver is well visualized within 5 minutes after administration. After this, the tracer is cleared from the liver and excreted into the biliary tree, the hepatic

ducts and, later, the gallbladder. In normally functioning hepatic ducts, activity will promptly flow into the duodenal sweep and proximal small bowel. The total time for this complete flow of IDA compounds should not exceed 45–60 minutes in normal patients. Normal scintigraphs of the hepatobiliary system ob-

tained with ^{99m}Tc -DISIDA are shown in Figure 1.5.

^{99m}Tc -DIMERCAPTOSUCCINIC ACID

^{99m}Tc -dimercaptosuccinic acid (DMSA) is a renal agent which was first introduced by Lin et al. (42); a detailed study of this agent has subse-

quently been made by Subramanian et al. (8). After intravenous injection, it is excreted in the urine by both glomerular filtration and tubular secretion. In humans, the renal uptake is about 12% of the administered dose at 1 hour after injection, with most of the dose localizing in the cortex, which results in a very high cortex-to-medulla activity ratio. This value is somewhat lower than the 48% quoted by Kawamura et al. (43). The blood clearance of ^{99m}Tc -DMSA in humans is slow ($t_{1/2} = \sim 10$ minutes), and there is no diffusion of the tracer into red cells. Approximately 75% of ^{99m}Tc -DMSA is loosely bound to plasma proteins initially. The amount of ^{99m}Tc -DMSA bound increases to 90% at 24 hours. Urinary excretion is about 37% at 24 hours.

Approximately 2–5 mCi of ^{99m}Tc -DMSA is injected intravenously, and renal images are obtained at the posterior position. Both kidneys are well visualized, with defects seen as cold spots. A number of investigators (43–46) have used this agent and have found that excellent renal images used to assess the differential status of both left and right kidneys have been obtained.

^{99m}Tc -LABELED RED BLOOD CELLS

Red blood cells (RBC) are labeled with ^{99m}Tc by both in vitro and in vivo methods. ^{99m}Tc -labeled RBC are primarily used for blood pool visualization and as denatured red cells for spleen imaging.

The biodistribution of ^{99m}Tc -labeled RBC in humans has been studied by Larson et al. (47). The blood disappearance curve has two components: one with a $t_{1/2}$ of 29 hours (95%) and another with a $t_{1/2}$ of 20 minutes. Approximately 5% of the activity is observed in the spleen due to either sequestration of damaged RBC or equilibration with splenic blood pool. The cardiac chambers are well visualized. In most cases, a myocardial halo of decreased activity is seen, lying between the left ventricular chamber and the lung blood pool. The ratio of the left ventricular activity to background activity is about 2.5–2.7. The normal cardiac blood pool occupies less than half of the total diameter of the chest at its widest dimension. Cardiomegaly is seen as an enlargement of the cardiac blood

pool, whereas a separation of the heart from the surrounding lung blood pool by more than 2 cm raises the probability of effusion (48).

When ^{99m}Tc -labeled RBC are denatured by heating at 50° for 15 minutes, they accumulate selectively in the spleen. Twenty minutes after injection, blood radioactivity falls below 50% of its maximum value (49). The plasma clearance curve is biphasic, and the ratio of unit area spleen-to-liver activity at the body surface exceeds 4:1 in normal patients (49).

^{99m}Tc -ALBUMIN

Human serum albumin labeled with ^{99m}Tc was introduced by McAfee et al. (50) for imaging placenta. A 15-mCi dose given by intravenous injection has been used for blood pool imaging. McAfee et al. (50) has observed that 5 minutes after injection, the first biological half-life of ^{99m}Tc -albumin is about 6 hours, with a subsequent component with a half-time of 3 days. In normal humans, less than 0.5% of the injected radioactivity is recovered in the urine or feces within the first 24 hours after injection. The placenta contains about 1% of the administered dose per 1% of the maternal body weight.

Cardiac chambers are well visualized by ^{99m}Tc -albumin. This tracer is not as good as ^{99m}Tc -labeled RBC for cardiac imaging, however, because albumin has a larger extravascular compartment of distribution than do RBC, which compromises the resolution of cardiac images. It has been pointed out by Rhodes (51) that various methodologies in the preparation of ^{99m}Tc -albumin influence the distribution of ^{99m}Tc -albumin primarily due to the presence of free and reduced technetium.

SODIUM [^{123}I] OR [^{131}I]IODIDE

Iodide normally is absorbed from food into the blood through the gastrointestinal tract, and its blood content reaches maximum within 3 hours. Radioiodide in blood is found mostly in plasma and to a lesser extent in RBC. The plasma clearance of iodide is exponential and rapid.

For thyroid studies, approximately 50 μCi of Na^{131}I or 300 μCi of Na^{123}I is administered orally, and uptake and imaging are performed at

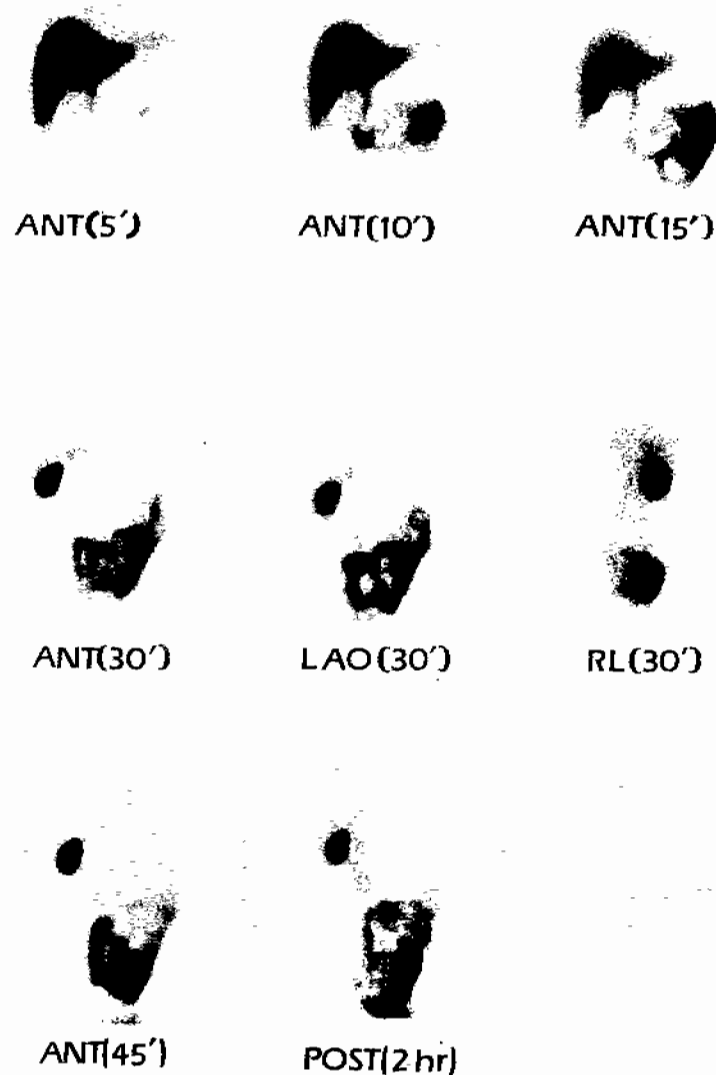

Figure 1.5. Normal scintigraphs of the hepatobiliary system obtained after administration of 5 mCi of ^{99m}Tc -DISIDA. ANT, anterior; LAO, left anterior oblique; RL, right lateral; POST, posterior.

24 hours. The thyroid gland extracts almost 20% of the iodide in a single pass from the blood that perfuses the gland. The iodide trap or pump concentrates iodide almost 25 times the plasma level, but the concentration may be increased as much as 500 times under certain conditions, such as iodide deficiency. The trapped iodide is oxidized by an enzyme to form iodine which then iodates tyrosine to produce moniodotyrosine (MIT) and diiodotyrosine (DIT). This process of iodination is called organification. MIT and DIT further condense to form T_3 and T_4 which are then bound to thyroglobulin, part of which is released in the blood circulation under the influence of thyroid-stimulating hormone (TSH).

The normal 24-hour thyroid uptake of iodine is 10–35%, but uptake varies because of the "cold" iodine content in food in different endemic areas. The high plasma level of iodide, or the presence of perchlorate, thiocyanate, chlorate, or iodate, or the administration of methimazole or propylthiouracil can reduce the thyroid uptake of iodide, whereas the administration of TSH would increase the uptake.

Other glands, such as salivary and gastric glands, concentrate iodide about as efficiently as the thyroid, although iodide in salivary and gastric secretions is not lost from the body, since it is reabsorbed from the intestinal tract (52). Iodide also accumulates in the kidneys, since it is filtered by the kidneys, and about 73% normally is reabsorbed by the tubules. Urinary excretion is 37–75% (53), fecal excretion is about 10%, and sweat excretion is almost negligible in 24 hours. The morphological distribution of iodide in the thyroid glands is similar to that of pertechnetate.

o -[^{131}I]IODOHIPPURATE (HIPURAN)

The primary use of ^{131}I -hippuran is in the assessment of renal function. When renography is performed, approximately 40–50 μCi of ^{131}I -hippuran is administered intravenously. If both renography and renal imaging are intended, however, about 250–300 μCi are injected. Renograms are obtained by tracing the flow of activity through each kidney against the time after injection. Imaging is performed every 5 minutes or so over a period of 45–60 minutes.

Hippuran is eliminated by the kidneys through glomerular filtration (20%) and tubular secretion (80%). The plasma clearance is very rapid (about 30 minutes). Normal adult hippuran clearance approximates 500–600 ml plasma per 1 minute, and 70% of the injected dose is excreted in the urine 35 minutes after injection. Depending on the degree of hydration of the patient, the peak renal concentration occurs in 2–5 minutes after injection (54–56). A dehydrated patient will demonstrate peak parenchymal activity slightly later and may have delayed clearance. Protein binding is about 60–70%, but the bond is very weak and thus dissociates rapidly. Whenever renal function is to be measured, free iodide in the ^{131}I -hippuran should be less than 3%; otherwise, effective renal plasma flow would be reduced considerably (57). An active transport mechanism accounts for the excretion of hippuran by renal tubules (58).

6β -[^{131}I]Iodomethyl-19-NORCHOLESTEROL (NP-59)

The compound 6β -[^{131}I]iodomethyl-19-norcholesterol (NP-59) is available from the University of Michigan and is used in a dose of 2 mCi for adrenal gland imaging. In dogs, 5%kg dose/gm \ddagger accumulates in the adrenal cortex as early as 2 days after the dose; the peak value of 8%kg dose/gm is reached at 10 days (59). Most accumulates in the cortex of the adrenal gland. The highest concentration of NP-59 is found in the thyroid glands and amounts to about 12–14%kg dose/gm at 10 days. Urinary excretion is about 29% in 9 days.

Images are obtained at 4–8 days after injection. Adrenal glands are seen as ovoid areas of persistent and fairly equal activity near the midline. Liver uptake is seen superior and lateral to the right adrenal gland. The gallbladder also is seen prior to 7 days after administration. A repeat scan after a fatty meal helps clarify most of these situations. Often bowel activity, particularly that seen on early images, can be eliminated by laxatives (60).

\ddagger %kg dose/gm

$$= \frac{\mu\text{Ci in organ/gm} \times \text{body weight in kg} \times 100}{\mu\text{Ci administered dose}}$$

^{125}I -LABELED FIBRINOGEN

^{125}I -labeled fibrinogen is primarily used for the detection of venous thrombus. Approximately 100 μCi of this agent are injected intravenously, and venous thrombi are detected by external counting at various sites over the lower extremities. The biological half-life normally is about 3.5–4.1 days, but about 33% of the administered dose has a half-life of about 12 hours. Almost 80% of the body's fibrinogen pool is within the circulating plasma volume. Its uptake is not specific for venous thrombosis because it also accumulates in surgical incisions, inflammatory lesions, and gross edema of lower extremities (61). Detection of thrombi with this agent is more accurate in postoperative patients than in patients with overt clinical manifestations.

[^{201}Tl]THALLOUS CHLORIDE

Various cardiovascular diseases are detected by several radiotracers, depending on the type of physiological handling of each radiotracer. Functioning myocardial cells can be imaged with radiopotassium or its analogs, such as ^{43}K , ^{82}Rb , ^{129}Cs , $^{13}\text{NH}_4^+$, and ^{201}Tl . Of these, ^{201}Tl has been the radiotracer of choice (62–64) because K^+ and Tl^+ are both monovalent cations of the same ionic size and therefore concentrate equally in the myocardium.

Approximately 1.5–2 mCi of ^{201}Tl in the form of thallos chloride are injected intravenously. Imaging is performed with a camera at different projections (mostly anterior, left anterior oblique (LAO), and left lateral) with the patient under resting and stress conditions. The blood clearance exhibits a biexponential curve consisting of components with $t_{1/2}$ of 5 minutes (92%) and 40 hours (8%) (65). The 24-hour urinary excretion is about 3–8% of the administered dose (64, 65). The myocardial extraction efficiency for ^{201}Tl in dogs is approximately 88% in a single pass under basal conditions (66). Maximum myocardial uptake is about 4% of the administered dose 10–25 minutes after injection (67). The thyroid uptake is about 0.2%, and the activity disappears in 24 hours. Approximately 0.15% of the dose accumulates in the testicles; 3%, in the kidneys; and 3–7% in the liver (65).

A normal thallium image is characterized by uniform distribution of ^{201}Tl activity throughout the left ventricular myocardium. A large area of decreased activity in the center is due to the left ventricular cavity. Decreased activity may be seen in the cardiac apex due to thinness of the posterior basal area of the myocardium. The proximal portions of the septum and posterior lateral wall, as seen in the LAO images, show somewhat nonuniform distribution of activity. The right ventricle often is seen on the exercise images, with little or no activity seen on the redistribution views.

The quality of ^{201}Tl images can be greatly enhanced by computer processing. The common methods involve background subtraction, contrast enhancement, and image filtering. Another approach has been to define quantitatively the relative distribution of ^{201}Tl in the myocardium as a function of space and/or time. This method has been accomplished with use of the computer and is called the washout technique. With this technique, one can assess the change of activity in a given area of the myocardium with time or the relative distribution of activity in different segments of the myocardium in a given projection. A new approach to tomographic imaging with use of a seven-pin-hole collimator, with which multiple tomographic slices of the heart can be obtained, has been suggested. Positioning of the heart (i.e., the patient) and loss in depth resolution are major disadvantages in the tomographic technique.

The extraction of thallium ion by myocytes requires that the cations traverse the capillary wall, interstitial space, and myocyte membrane. The barrier at the capillary wall is dependent on blood flow, and cations are transported across the cell membrane by the active transport mechanism via the $\text{Na}^+ - \text{K}^+ - \text{ATPase}$ pump (68, 69). Since the viable cells take up these radiotracers, myocardial infarcts would be seen as cold spots. Myocardial imaging during peak exercise and then at rest can distinguish between infarcts and ischemic regions. A cold area in both sets of images would indicate an infarct, while a cold area that fills in at rest would suggest ischemia. The thallium uptake is decreased in ischemic hypoxia resulting from a decreased blood flow (70).

[⁶⁷Ga]GALLIUM CITRATE

[⁶⁷Ga]gallium citrate is most commonly used for the diagnosis of neoplasms, Hodgkin's disease, and abscesses. For imaging, approximately 2–10 mCi are injected intravenously, and whole-body imaging is performed at 24, 48 and, sometimes, 72 hours later to obtain unequivocal information. The biodistribution of ⁶⁷Ga has been studied extensively by Hayes and his group (71–73).

When carrier-free [⁶⁷Ga]gallium citrate is administered intravenously, most of ⁶⁷Ga is bound to plasma protein, specifically to transferrin. Urinary excretion is nearly 15% in 24 hours, fecal excretion is nearly 10% in 24 hours, and the remaining activity stays in the body (74). Gallium is secreted by the large bowel and becomes prominent after 1 or 2 days. During the scanning period (i.e., between 24 hours and 72 hours), the highest concentrations are seen in the bone, liver, and spleen. About one third of

the tracer is excreted over the first week, and the remaining two thirds is distributed in the liver (6%), spleen (1%), kidney (2%), skeleton (including marrow) (24%), and other soft tissues (34%). Relatively high concentrations are also observed in the adrenals, the large bowel, and the lungs. Under certain physiological conditions, intense localization may occur within the breast and long bones, and these variations may mimic malignant tumors (75). Slight uptake of ⁶⁷Ga in normal lungs has been noted by Braude et al. (76). The normal distribution of ⁶⁷Ga is affected by various agents, such as iron dextran, deferoxamine, chemotherapeutic agents, antibiotics, and estrogens (77). A normal distribution of [⁶⁷Ga]gallium citrate is shown in Figure 1.6.

Subcellular fractionation studies by Hayes and Carlton (78) showed that ⁶⁷Ga is primarily bound to two proteins with molecular weights of about 100,000 and 50,000 daltons in rat tumor and liver. The ⁶⁷Ga uptake is influenced by vascularity, increasing permeability, and rapid proliferation of the tumor cells. Hoffer et al.

(79) proposed that ⁶⁷Ga binds to the lactoferrin present in body tissues and polymorphonuclear leukocytes and that the ⁶⁷Ga-bound lactoferrin perhaps is responsible for gallium localization in tumors, inflammatory diseases, and abscesses. Larson (80), however, proposed that the ⁶⁷Ga uptake is mediated by transferrin-specific receptors on the cell membrane.

¹¹¹IN-LABELED LEUKOCYTES

¹¹¹In-labeled leukocytes are used for the detection of inflammatory diseases such as abscesses (81–84). Autologous leukocytes are labeled with ¹¹¹In-oxine (85), and 200–500 μCi of labeled cells are injected intravenously. Imaging is commonly performed at 24 hours but can be performed as early as 12 hours after injection.

The plasma disappearance half-time is of the order of 5–7 hours (81, 86). Urinary excretion is negligible (86). The in vivo distribution of ¹¹¹In-labeled leukocytes reflects the normal pattern of distribution of leukocytes. Approximately 50% of the cells accumulate in the liver; about 11%, in the spleen; and about 8%, in the lungs. Most of the activity in the lungs represents background activity over the entire chest area and does not appear on the scan as a focal spot (87).

A variety of inflammatory diseases can be detected by the use of ¹¹¹In-labeled leukocytes. Abdominal abscesses, renal inflammation, and active colitis, among others, are the most common. Disadvantages in the use of ¹¹¹In-labeled leukocytes are long time of preparation (~2 hours) and high radiation dose to the liver and spleen (4 rad and 24 rad/mCi) (86).

The leukocyte uptake in the abscesses or inflammatory diseases is effected by the migration of these cells through the capillary wall to the point of injury or infection. This migration is caused by the release of a polypeptide known as leukotoxine which increases the capillary permeability.

¹¹¹IN-LABELED PLATELETS

¹¹¹In-labeled platelets have been used in humans for the detection of thrombi, measurement of platelet survival, and other kinetics, and in several laboratories, this method has replaced

the conventionally used ⁵¹Cr-labeled platelets. The in vivo kinetics and distribution of ¹¹¹In-labeled platelets in humans have been reported by several investigators (88–93). The mean survival time of ¹¹¹In-labeled autologous platelets, based on linear fitting of the data, is 8.8 days (91) which is the same as that reported by Wahner et al (90). Shorter survival times are obtained if the data are fitted with an exponential function. The mean recovery of ¹¹¹In-labeled platelets varies from 57% to 75% (88, 92, 93). Much of the variation is due to differences in methodologies applied to measure the platelet recovery.

Immediately after injection, ¹¹¹In activity decreases rapidly in the blood but increases in the spleen and the liver to relatively plateau values within 20–30 minutes (90). The latter values change only a little over a long period of time. The spleen uptake is found to be approximately 40% at 7–9 days, while the liver uptake ranges between 13% and 25% (90, 91). The liver activity is due to sequestration of damaged platelets. There is no discernible accumulation in the lungs or in the abdomen outside the spleen or liver. At a later time (9 days after injection), slight visualization of bone marrow is observed.

[⁷⁵Se]SELENOMETHIONINE

Pancreas imaging is performed with [⁷⁵Se]selenomethionine; the usual intravenous dose is 250 μCi. Approximately 6–7% of the administered dose accumulates in the pancreas within 1 hour after administration (94). The biologic half-life is about 47 days. Urinary excretion and fecal excretion are about 80% and 15%, respectively.

Selenomethionine is utilized in the synthesis of pancreatic enzymes in the pancreas. As an amino acid, however, it accumulates in the salivary glands, liver, and small intestine. For these reasons, often the pancreatic image is obscured by the liver and surrounding activities.

¹³³Xe

¹³³Xe is an inert gas relatively insoluble in water but slightly soluble in blood and fat. ¹³³Xe gas is used for the lung ventilation study in order to determine the airway patency of the lungs. Ten to 15 mCi of ¹³³Xe gas are mixed



Figure 1.6. A normal ⁶⁷Ga scan at 48 hours. A. Anterior. B. Posterior.

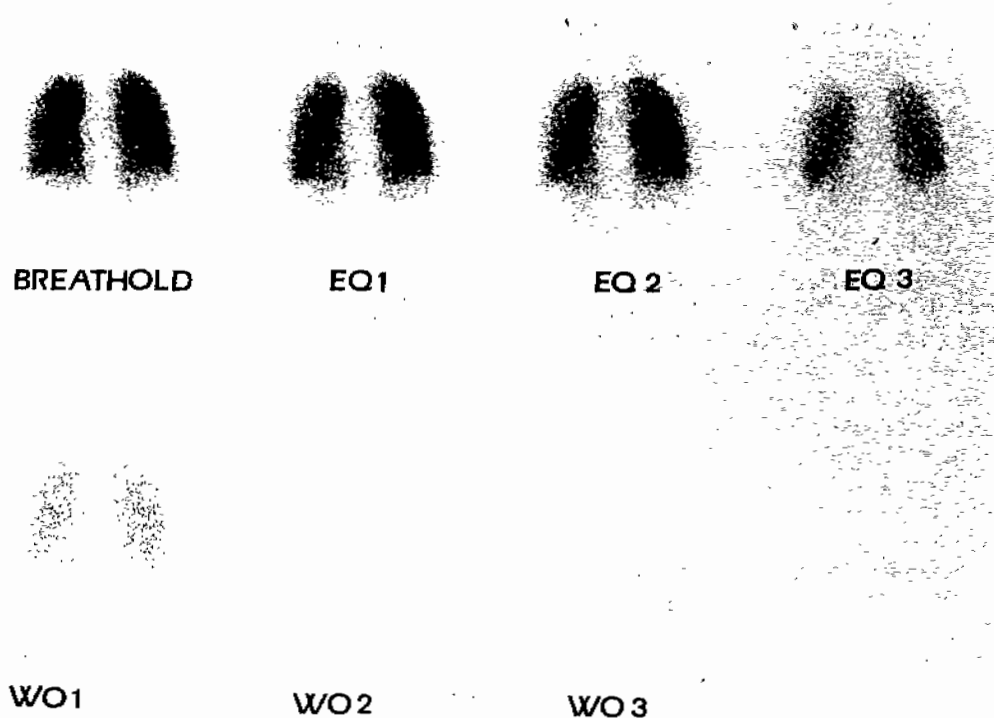

Figure 1.7. Normal lung ventilation scintigraphs obtained after administration of ^{133}Xe . EQ, equilibrium; WO, washout.

with air in a closed-system xenon machine for each patient. The patient is asked to inhale ^{133}Xe from the machine and to hold the breath for 15–35 seconds. At this time, a single-breath image is obtained. For the next 4–5 minutes, the patient rebreathes the mixture in the closed system, and equilibrium images are obtained. The next phase of the study is the “washout” in which the patient inhales fresh air and exhales ^{133}Xe into the system containing a xenon-absorbing charcoal filter. Several images are obtained over a period of 4–5 minutes during this “washout” phase. Imaging is performed with the patient in the upright position, and posterior views are obtained. The ^{133}Xe gas distributes itself throughout the lungs in a uniform pattern in patients with normal ventilation, and the even distribution corresponds to the lung volume. Clearance of xenon from the lungs is rapid, and in normal men, lung outlines are not seen 3–5 minutes after initiation of washout. ^{133}Xe ac-

tivity may be seen in the liver during the washout period due to fatty content of the liver and thus gives the appearance of delayed clearance from the right base (95). Any airway obstruction is indicated by retention of activities in the area. Regions with decreased activity on the single-breath view are considered abnormal (96–99). Normal ventilation scintigraphs are shown in Figure 1.7.

ACKNOWLEDGMENTS

Scintigraphs for Figures 1.1, 1.2, 1.3, 1.5, and 1.7 were kindly supplied by Robert A. Johnson, M.D., Presbyterian Hospital, Albuquerque, NM.

REFERENCES

- Hays MT, Green FA: In vitro studies of pertechnetate-99m binding by human serum and tissues. *J Nucl Med* 14:149–158, 1977.

- Beasley TM, Palmer HE, Nelp WB: Distribution and excretion of technetium in humans. *Health Phys* 12:1425–1435, 1966.
- Witofski RL, Janeway R, Maynard D, et al: Visualization of the choroid plexus on the technetium-99m brain scan. Clinical significance and blocking by potassium perchlorate. *Arch Neurol* 16:286–289, 1967.
- Houser W, Atkins HL, Nelson KG, et al: Technetium-99m-DTPA: a new radiopharmaceutical for brain and kidney imaging. *Radiology* 94:679–684, 1970.
- Atkins HL, Cardinale KG, Eckelman WC, et al: Evaluation of $^{99\text{m}}\text{Tc}$ -DTPA prepared by three different methods. *Radiology* 98: 674–677, 1971.
- Wilson AJ, Mistry RD, Maisey MN: $^{99\text{m}}\text{Tc}$ -DTPA for the measurement of glomerular filtration rate. *Br J Radiol* 49:794–796, 1976.
- Rossing N, Bojsen J, Federiksen PL: The glomerular filtration rate determined with $^{99\text{m}}\text{Tc}$ -DTPA and a portable cadmium telluride detector. *Scand J Clin Lab Invest* 38:23–28, 1978.
- Arnold RW, Subramanian G, McAfee JC, et al: Comparison of $^{99\text{m}}\text{Tc}$ -complexes for renal imaging. *J Nucl Med* 16:357–367, 1975.
- Taplin GV, McDonald NS: Radiochemistry of macroaggregated albumin and newer lung scanning agents. *Semin Nucl Med* 1:132–139, 1971.
- Chandra R, Shamoun J, Braunstein P, et al: Clinical evaluation of an instant kit for preparation of $^{99\text{m}}\text{Tc}$ -MAA. *J Nucl Med* 14:702–705, 1973.
- Wagner HN, Rhodes BA, Sasaki Y, et al: Studies of the circulation with radioactive microspheres. *Invest Radiol* 4:374–386, 1969.
- Wagner HN, Jr, Sabiston DC Jr, McAfee JE, et al: Diagnosis of massive pulmonary embolism in man by radioisotope scanning. *N Engl J Med* 271:377–384, 1964.
- Tauxe WN, Burchell HB, Black LF: Clinical application of lung scanning. *Mayo Clin Proc* 42:473–487, 1967.
- Robbins PJ, Feller PA, Nishiyama H: Evaluation and dosimetry of a $^{99\text{m}}\text{Tc}$ -Sn-MAA lung imaging agent in humans. *Health Phys* 30:173–178, 1976.
- Tetelman MR, Hoffer PB, Heck LL, et al: Perfusion lung scans in normal volunteers. *Radiology* 106: 593–594, 1973.
- Friedman SA, Schub HM, Smith EH, et al: Perfusion defects in the aging lung. *Am Heart J* 79:160–166, 1970.
- Kronenberg RS, L'heureux P, Ponto RA, et al: The effect of aging on lung perfusion. *Ann Intern Med* 76:413–421, 1972.
- Saba TM: Physiology and pathophysiology of the reticuloendothelial system. *Arch Intern Med* 126: 1031–1050, 1970.
- Nelp WB: An evaluation of colloids for RES function studies. In Subramanian G, Rhodes BA, Cooper JF, et al (eds): *Radiopharmaceuticals*. New York, Society of Nuclear Medicine, 1975, p 349.
- Shaldon S, Chianidussi L, Guevara L, et al: The estimation of hepatic blood flow and intrahepatic shunted blood flow by colloidal heat denatured human serum albumin labeled with I-131. *J Clin Invest* 40: 1346–1354, 1961.
- Klingensmith WC, Ryerson TW: Lung uptake of $^{99\text{m}}\text{Tc}$ -sulfur colloid. *J Nucl Med* 14:201–204, 1973.
- Michael MA, Evans RG: Migration and embolization of macrophages to the lung—a possible mechanism for colloid uptake in the lung during liver scanning. *J Nucl Med* 16:22–27, 1975.
- Ege GN: Internal mammary lymphoscintigraphy—the rationale, technique, interpretation and clinical application: a review based on 848 cases. *Radiology* 118:101–107, 1976.
- Subramanian G, McAfee JC, Blair RJ, et al: Technetium-99m-methylene diphosphonate—a superior agent for skeletal imaging: comparison with other technetium complexes. *J Nucl Med* 16:744–755, 1975.
- Saha GB, Boyd CM: A study of protein-binding of $^{99\text{m}}\text{Tc}$ -methylene diphosphonate in plasma. *Int J Nucl Med Biol* 6:201–206, 1979.
- Saha GB, Boyd CM: Plasma protein-binding of $^{99\text{m}}\text{Tc}$ -pyrophosphate. *Int J Nucl Med Biol* 5:236–239, 1978.
- Bevan JA, Tofe AJ, Benedict JJ, et al: Tc-99m HMDP (hydroxymethylene diphosphonate): a radiopharmaceutical for skeletal and acute myocardial infarct imaging. I. Synthesis and distribution in animals. *J Nucl Med* 21:961–966, 1980.
- Bevan JA, Tofe AJ, Benedict JJ, et al: Tc-99m HMDP (hydroxymethylene diphosphonate): a radiopharmaceutical for skeletal and acute myocardial infarct imaging. II. Comparison of Tc-99m hydroxymethylene diphosphonate (HMDP) with other technetium-labeled bone imaging agents in a canine model. *J Nucl Med* 21:967–970, 1980.
- Fogelman I, Pearson DW, Bessent RG, et al: A comparison of skeletal uptakes of three diphosphonates by whole-body retention: concise communication. *J Nucl Med* 22:880–883, 1981.
- Willerson JT, Parkey RW, Bonte FJ, et al: Technetium stannous pyrophosphate myocardial scintigrams in patients with chest pain of varying etiology. *Circulation* 51:1046–1052, 1975.
- Loberg MD, Cooper M, Harvey E, et al: Development of new radiopharmaceuticals based on N-substitution of iminodiacetic acid. *J Nucl Med* 17:633–638, 1976.
- Wistow BW, Subramanian G, Van Heertum RL, et al: An evaluation of $^{99\text{m}}\text{Tc}$ -labeled hepatobiliary agents. *J Nucl Med* 18:455–461, 1977.
- Pare P, Shaffer EA, Rosenthal L: Nonvisualization of the gallbladder by $^{99\text{m}}\text{Tc}$ -HIDA cholescintigraphy as evidence of cholecystitis. *Can Med Assoc J* 118: 384–386, 1978.
- Rosenthal L, Shaffer EA, Lisbona R, et al: Diagnosis of hepatobiliary disease by $^{99\text{m}}\text{Tc}$ -HIDA cholescintigraphy. *Radiology* 126:467–474, 1978.
- Weissmann HS, Sugarman LA, Freeman LM: The clinical role of technetium-99m iminodiacetic acid cholescintigraphy. *Nucl Med Ann* 35–89, 1981.
- Jansholt AL, Vera DR, Krohn KA, et al: In vivo kinetic

- ics of hepatobiliary agents in jaundiced animals. In Sodd VJ, Hoogland DR, Allen DR, et al (eds): *Radiopharmaceuticals II*. New York, Society of Nuclear Medicine, 1979, p 555.
37. Hernandez M, Rosenthal L: A cross-over study comparing the kinetics of Tc-99m-labeled isopropyl and *p*-butyl IDA analogs in patients. *Clin Nucl Med* 5: 159-165, 1980.
 38. Klingensmith WC, Fritzbeg AR, Spitzer VM, et al: Clinical comparison of ^{99m}Tc-diethyl-IDA and ^{99m}Tc-PIPIDA for evaluation of the hepatobiliary system. *Radiology* 134:195-199, 1980.
 39. Klingensmith WC, Fritzbeg AR, Spitzer VM, et al: Clinical comparison of Tc-99m diisopropyl-IDA and diethyl-IDA for evaluation of the hepatobiliary system. *Radiology* 140:791-795, 1981.
 40. Ohi R, Klingensmith WC, Lilly JR: Diagnosis of hepatobiliary disease in infants and children with Tc-99m-diethyl-IDA imaging. *Clin Nucl Med* 6: 297-302, 1981.
 41. Package insert: Hepatolyte-Tc-99m disofenin kit. New England Nuclear, North Billerica, MA, 1982.
 42. Lin TH, Khentigan A, Winchell HS: A ^{99m}Tc-chelate substitute for organomercurial renal agents. *J Nucl Med* 15:34-35, 1974.
 43. Kawamura J, Hosokawa S, Yoshida O: Renal function studies using ^{99m}Tc-dimercaptosuccinic acid. *Clin Nucl Med* 4:39-46, 1979.
 44. Handmaker H, Young BW, Lowenstein JM: Clinic experience with ^{99m}Tc-DMSA (dimercaptosuccinic acid), a new renal-imaging agent. *J Nucl Med* 16:28-32, 1975.
 45. Daly MJ, Milutinovic J, Rudd TG, et al: The normal ^{99m}Tc-DMSA renal image. *Radiology* 128:701-704, 1978.
 46. Daly MJ, Jones W, Rudd TG, et al: Differential renal function using technetium-99m dimercaptosuccinic acid (DMSA): in vitro correlation. *J Nucl Med* 20: 63-66, 1979.
 47. Larson SM, Hamilton GW, Richards P, et al: Kit-labeled technetium-99m labeled red blood cells (Tc-99m-RBC's) for clinical cardiac chamber imaging. *Eur J Nucl Med* 3:227-231, 1978.
 48. Wagner HN, McAfee JG, Mozley JM: Diagnosis of pericardial effusion by radioisotope scanning. *Arch Intern Med* 108:679-684, 1961.
 49. Johnson PM, Herion JC: Technical considerations in scintillation scanning of the spleen. *Radiology* 76: 438-443, 1961.
 50. McAfee JG, Stern HS, Fueger GF, et al: ^{99m}Tc-labeled serum albumin for scintillation scanning of the placenta. *J Nucl Med* 5:936-946, 1964.
 51. Rhodes BA: Considerations in the radiolabeling of albumin. *Semin Nucl Med* 4:281-293, 1974.
 52. Vought RL, London WT: Iodine intake and excretion in healthy nonhospitalized subjects. *Am J Clin Nutr* 15:124-132, 1964.
 53. McConahey WM, Owen CA Jr, Keating FR Jr: A clinical appraisal of radioiodine tests of thyroid function. *J Clin Endocrinol* 16:724-734, 1956.
 54. Tauxe WN, Hunt JC, Burbank MK: The radioisotope renogram (ortho-iodo-hippurate-I-131): standardization of techniques and expression of data. *Am J Clin Pathol* 37:567-583, 1962.
 55. Tauxe WN, Burbank MK, Maher FT, et al: Renal clearances of radioactive orthoiodohippurate and diatrizoate. *Mayo Clin Proc* 39:761-766, 1964.
 56. Tauxe WN, Maher FT, Taylor WF: Effective renal plasma flow estimation from theoretical volumes of distribution of intravenously injected ¹³¹I-orthoiodohippurate. *Mayo Clin Proc* 46:524-551, 1971.
 57. Burbank MK, Tauxe WN, Maher FT, et al: Evaluation of radioiodinated hippuran for the estimation of renal plasma flow. *Mayo Clin Proc* 36:372-386, 1961.
 58. Weiner IM, Mudge GH: Renal tubular mechanisms for excretion of organic acids and bases. *Am J Med* 36:743-762, 1964.
 59. Sarkar SD, Beierwaltes WH, Ice RD, et al: A new and superior adrenal scanning agent, NP-59. *J Nucl Med* 16:1038-1042, 1975.
 60. Seabold JE, Beierwaltes WH: Adrenal imaging. In Schneider PB, Treves S (eds): *Nuclear Medicine in Clinical Practice*. New York, Elsevier, 1978, p 201.
 61. McAfee JG, Subramanian G: Radioactive agents for imaging. In Freeman LM (ed): *Freeman and Johnson's Clinical Radionuclide Imaging*, ed 3. New York, Grune & Stratton, 1984, p 55.
 62. Wackers FJT, Sokole EB, Samson G, et al: Value and limitations of Tl-201 scintigraphy in the acute phase of myocardial infarction. *N Engl J Med* 295:1-5, 1976.
 63. Strauss HW, Pitt B: Tl-201 as a myocardial imaging agent. *Semin Nucl Med* 7:49-58, 1977.
 64. Schelbert HR, Henning H, Rigo P, et al: Considerations of ²⁰¹Tl as a myocardial radionuclide imaging agent in man. *Invest Radiol* 11:163-171, 1976.
 65. Atkins HL, Budinger TF, Lebowitz E, et al: Thallium-201 for medical use. Part 3. Human distribution and physical imaging properties. *J Nucl Med* 18:133-140, 1977.
 66. Weich HF, Strauss HW, Pitt B: The extraction of thallium-201 by the myocardium. *Circulation* 56: 188-191, 1977.
 67. Bradley-Moore PR, Lebowitz E, Greene MW, et al: Thallium-201 for medical use. II. Biologic behavior. *J Nucl Med* 16:156-160, 1975.
 68. Tancredi RG, Yipintsoi T, Bassingthwaite: Capillary and cell wall permeability to potassium in isolated dog hearts. *Am J Physiol* 229:537-544, 1975.
 69. Strauss HW, Harrison K, Langan JK, et al: Thallium-201 for myocardial imaging: relation of thallium-201 to regional myocardial perfusion. *Circulation* 51:641-645, 1975.
 70. Levenson WI, Adolph RJ, Romhilt DW, et al: Effects of myocardial hypoxia and ischemia on myocardial scintigraphy. *Am J Cardiol* 35:251-257, 1975.
 71. Harbman RE, Hayes RL: The binding of gallium and indium by blood serum proteins. In: *1967 Research Report, Medical Division, Oak Ridge Associated Universities*, ORAU-106, Oak Ridge, TN, Oak Ridge Associated Universities, 1967.
 72. Edwards CL, Hayes RL, Nelson B, et al: Radioactive gallium uptake in tumors. In: *1969 Research Report, Medical Division, Oak Ridge Associated Universities*, ORAU-110, Oak Ridge, TN, Oak Ridge Associated Universities, 1969.
 73. Nelson BM, Hayes RL, Edwards CL, et al: Distribution of gallium in human tissues after intravenous administration. *J Nucl Med* 13:92-100, 1972.
 74. Edwards CL, Hayes RL, Nelson BM, et al: Clinical investigation of ⁶⁷Ga for tumor imaging. *J Nucl Med* 11:316-317, 1970.
 75. Larson SM, Milder MS, Johnston GS: Interpretation of the ⁶⁷Ga photoscan. *J Nucl Med* 14:208-214, 1973.
 76. Braude AC, Chamberlain DW, Rebeck AS: Pulmonary disposition of gallium-67 in humans: concise communication. *J Nucl Med* 23:574-576, 1982.
 77. Hladik WB, Nigg KK, Rhodes BA: Drug-induced changes in the biologic distribution of radiopharmaceuticals. *Semin Nucl Med* 12:184-218, 1982.
 78. Hayes RL, Carlton JE: A study of the macromolecular binding of ⁶⁷Ga in normal and malignant animal tissues. *Cancer Res* 33:3265-3272, 1973.
 79. Hoffer PB, Huberty J, Khayam-Bashi H: The association of Ga-67 and lactoferrin. *J Nucl Med* 18: 713-717, 1977.
 80. Larson SM: Mechanism of localization of gallium-67 in tumors. *Semin Nucl Med* 8:193-203, 1978.
 81. Thakur M, Lavender J, Arnot R, et al: Indium-111 labeled autologous leukocytes in man. *J Nucl Med* 18:1014-1021, 1977.
 82. Coleman RE, Black RE, Welch DM, et al: Indium-111 labeled leukocytes in the evaluation of suspected abdominal abscess. *Am J Surg* 139:99-104, 1980.
 83. Carroll B, Silverman PM, Goodwin DA, et al: Ultrasonography and indium-111 white blood cell scanning for the detection of intraabdominal abscesses. *Radiology* 140:155-160, 1981.
 84. Bicknell TA, Kohatsu S, Goodwin DA: Use of indium-111-labeled autologous leukocytes in differentiating pancreatic abscess from pseudocyst. *Am J Surg* 142:312-316, 1981.
 85. Clay ME, McCullough J, Forstrom LA: Indium-111-labeled leukocytes: preparation and labeling technique. In Wahner HW, Goodwin DA (eds): *111-Indium-labeled Platelets and Leukocytes*. Crystal Lake, IL, Central Chapter, Society of Nuclear Medicine, 1981, p 57.
 86. Williams LE, Forstrom LA, Weiblen BJ, et al: Estimates of dosimetry for In-111 granulocytes. In Wahner HW, Goodwin DA (eds): *111-Indium-labeled Platelets and Leukocytes*. Crystal Lake, IL, Central Chapter, Society of Nuclear Medicine, 1981, p 173.
 87. Weiblen BJ, McCullough J, Forstrom LA, et al: Kinetics of In-111-labeled granulocytes. In Thakur ML, Gottschalk A (eds): *In-111 Labeled Neutrophils, Platelets, and Lymphocytes*. Proceedings of the Yale Symposium. New York, Trivium Publishing Company, 1980, p 23.
 88. Heaton WA, Davis HH, Welch MJ, et al: Indium-111: a new radionuclide label for studying human platelet kinetics. *Br J Haematol* 42:613-622, 1979.
 89. Van Reenen OR, Lotter MG, Minnaar PC, et al: Radiation dose from human platelets labelled with indium-111. *Br J Radiol* 53:790-795, 1980.
 90. Wahner HW, Dunn WL, Dewanjee MK: Distribution and survival of ¹¹¹In-labeled platelets in normal persons. In Wahner HW, Goodwin DA (eds): *111-Indium-labeled Platelets and Leukocytes*. Crystal Lake, IL, Central Chapter, Society of Nuclear Medicine, 1981, p 277.
 91. Scheffel LL, Tsan M, Mitchell TG, et al: Human platelets labeled with In-111 8-hydroxyquinoline: kinetics, distribution and estimates of radiation dose. *J Nucl Med* 23:149-156, 1982.
 92. Heyns AD, Lotter MG, Badenhorst PN, et al: Kinetics, distribution and sites of destruction of ¹¹¹indium labeled human platelets. *Br J Haematol* 44:269-280, 1980.
 93. Robertson JS, Dewanjee MK, Brown ML, et al: Distribution and dosimetry of ¹¹¹In-labeled platelets. *Radiology* 140:149-176, 1981.
 94. Lathrop KA, Honston RE, Blau M, et al: Radiation dose to humans from ⁷⁵Se-selenomethionine. *J Nucl Med* (MIRD suppl 6, pamphlet 9): 10, 1972.
 95. Carey JE, Purdy JM, Moses DC: Localization of ¹³³Xe in liver during ventilation studies. *J Nucl Med* 15:1179-1181, 1974.
 96. Alderson PO, Secker-Walker RH, Forrest JV: Detection of pulmonary disease. *Radiology* 111:643-648, 1978.
 97. Alderson PO, Lee H, Summer WR, et al: Comparison of Xe-133 washout and single breath imaging for the detection of ventilation abnormalities. *J Nucl Med* 20:917-922, 1979.
 98. Millic-Emile J: Radioactive xenon in the evaluation of regional lung function. *Semin Nucl Med* 1:246-252, 1971.
 99. Anderson PO, Bruce RL: Scintigraphic evaluation of regional pulmonary ventilation. *Semin Nucl Med* 10:218-242, 1980.

2

Radiopharmacokinetics in Nuclear Medicine

Jeffrey A. Clanton

Radiopharmacokinetics is the study of the time course of radiopharmaceutical distribution in the various fluids, organ systems, and excreta of the body and the use of mathematical relationships to model and interpret these data. The ultimate goal of radiopharmacokinetics is as diverse as its definition. To some, the goal is to develop a better or more selective radiopharmaceutical. Others may use the models and information derived from the data to calculate radiation dosimetry. The most prevalent use of the data, however, is to assess organ function for diagnostic purposes.

BASICS

In order to develop an appropriate mathematical model after experimental data have been collected, assumptions regarding compartmental distribution of the tracer must be made. The most common method employed for pharmacokinetic modeling is to represent the body as a series of compartments (1). This, like other methods, is not without limitation. The major problem is to find a sufficient, yet not exhaustive, method of mathematically describing one or more groups of pharmacodynamic data. A "compartmentalized system" is, therefore, an average of the physiological system rather than an exact representation (2).

There are three major steps in the complete kinetic evaluation of experimental data (3):

1. Choice of the most appropriate pharmacokinetic model
2. Fitting of the model curve(s) to the experimental data
3. Use of derived model(s) and parameters for prediction

This chapter is focused on the details of the first and third steps of kinetic analysis, with introductory information provided on step 2.

Single Compartmental Analysis

Of the compartmental models that can be utilized, the one-compartment model is the most simple. In this model, the body is depicted as one large homogeneous unit, and it is assumed that changes in plasma drug levels quantitatively reflect changes in tissue drug levels. It is also assumed that the drug is eliminated in a single-exponential or first-order fashion (Fig. 2.1). After it has been determined that the one-compartment model is suitable for the experimental data, the following equation can be applied:

$$X = X_0 e^{-kt} \quad \text{Equation 2.1}$$

where X_0 is the amount of drug injected, X is the amount of drug remaining in the compartment at time t , and k is the first-order elimination rate constant.

Equation 2.1 is of little importance, however, because X cannot be determined in vivo. With this model, it is assumed that the total biological system is one compartment; it can be further assumed, therefore, that there is a relationship between the drug concentration in plasma (C) and the amount of drug (X) in the compartment. This assumption leads to the following equation (1):

$$X = VC \quad \text{Equation 2.2}$$

In this equation, the constant V has units of volume and is known as the volume of distribution. The volume of distribution usually does not have direct physiological significance or re-

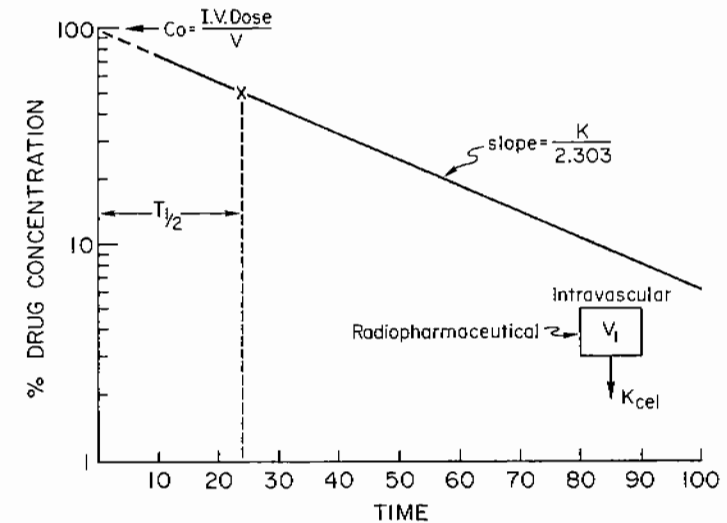

Figure 2.1. Semilogarithmic graph of plasma concentration as a function of time. The data follow a single-exponential decline that is described by Equation 2.3.

fer to actual blood volumes, however, as V may be as much as several hundred liters in a 70-kg man. The relationship (Equation 2.2) between the amount of drug (X) in the compartment and the drug concentration (C) enables the conversion of Equation 2.1 from an amount-time to a concentration-time relationship as follows:

$$\text{Log } C = \text{Log } C_0 - \frac{kt}{2.303} \quad \text{Equation 2.3}$$

where C_0 is the plasma concentration immediately after injection. Since X_0 equals the amount of the drug injected and C_0 can be extrapolated from the plot of the data generated with Equation 2.3, the volume of the distribution can be estimated with the following equation:

$$V = \frac{\text{Intravenous dose}}{C_0} \quad \text{Equation 2.4}$$

Radiopharmaceuticals that can be studied with use of the one-compartment model include: labeled albumin or red blood cells for blood pool imaging, ^{133}Xe for pulmonary ventilation, labeled particles for lung perfusion studies, and $^3\text{H}_2\text{O}$ for total body water determinations (4).

Multicompartmental Analysis (Passive)

Often, radiopharmaceutical distribution is too complex to be interpreted by a single-compartment model. In these cases, it becomes necessary to include two or more compartments in the model to obtain a more definitive assessment. Normally, kinetic data can be separated into two large but different compartments. The larger (central) compartment would be considered the blood and all highly vascular organs. A smaller (peripheral) compartment consisting of all poorly perfused tissue (i.e., lean tissue and fat) could then be established. As with the single-compartment passive diffusion model, elimination is assumed to be first order, as is the distribution between the two (or more) compartments (5) (Fig. 2.2).

As would be expected, the multicompartment model is used to analyze a radiopharmaceutical when the plasma clearance is multiexponential (Fig. 2.3). If a two-compartment model is used, plasma clearance of the radiopharmaceutical is biexponential. If the model is further defined to have excretion out of the central compartment (Fig. 2.2A), its mathematical model would resemble the following equation:

$$X_c = \frac{X_0 (\alpha - K_{21})}{\alpha - \beta} e^{-\alpha t} + \frac{X_0 (K_{21} - \beta)}{\alpha - \beta} e^{-\beta t} \quad \text{Equation 2.5}$$

where X_c is the amount of drug in the central

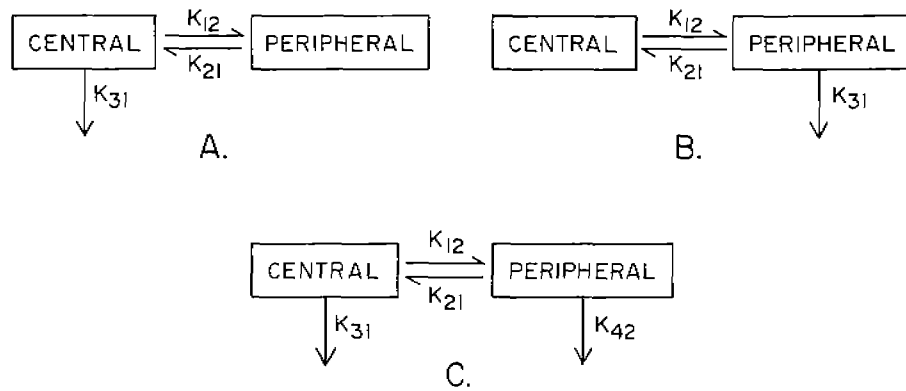

Figure 2.2. A diagrammatic representation of three types of two-compartment systems that consist of a central and peripheral compartment. *A* demonstrates excretion from the central compartment, *B* demonstrates excretion from the peripheral compartment, and *C* demonstrates excretion from both compartments.

compartment, X_0 is the amount of drug in the central compartment at time zero, and α and β are complex constants used to replace other constants (i.e., $\alpha = (K_{21}K_{31})/\beta$, $\beta = F_c K_{31}$, and $F_c =$ fraction of the drug in the central compartment).

Radiopharmaceuticals that require analysis by a passive diffusion multicompartment model include the following: ^{99m}Tc -DTPA, ^{99m}Tc -gluconate, and $^{99m}\text{TcO}_4^-$ for brain imaging, ^{18}F ,

$^{87\text{m}}\text{Sr}$, ^{67}Ga , and $^{99\text{m}}\text{Tc}$ -labeled phosphorus compounds for bone imaging, $^{99\text{m}}\text{Tc}$ - or ^{111}In -DTPA for cisternography, and $^{99\text{m}}\text{Tc}$ -DTPA for renal studies (4, 6).

Active or Nonlinear Analysis

All radiopharmaceuticals that undergo biotransformation or other active processes (i.e., renal tubular secretion and certain hepatobiliary secretion processes) require a single-compartment

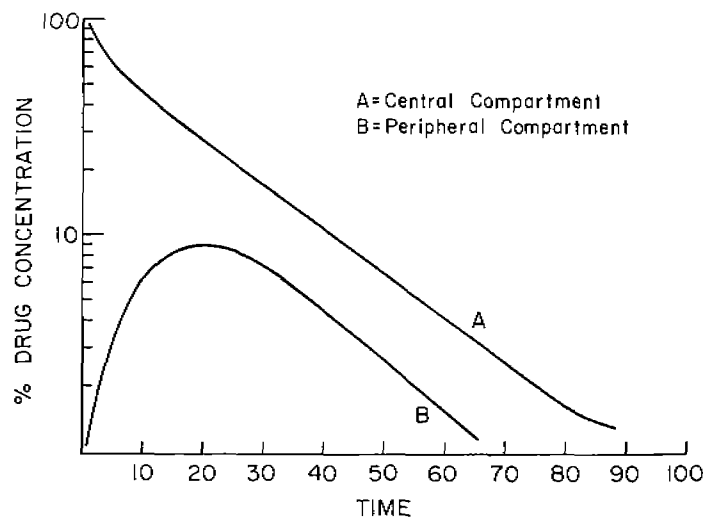

Figure 2.3. A semilogarithmic graph of the amount of drug in the central (*A*) and peripheral (*B*) compartments as a function of time. This drug exhibits the pharmacokinetic characteristics of a two-compartment model.

ment or multicompartment nonlinear model for analysis (Fig. 2.4). These processes may be capacity limited, which requires the use of specialized techniques to describe their kinetics. The equation used most frequently for their mathematical description is the Michaelis-Menten equation (7, 8):

$$-\frac{dC}{dt} = \frac{V_m C}{K_m + C} \quad \text{Equation 2.6}$$

where $-dC/dt$ is the rate of decrease of the radiopharmaceutical from the compartment at time t , V_m is the theoretical maximum rate of the active process being studied, and K_m is the Michaelis-Menten constant.

Radiopharmaceuticals that require the use of nonlinear analysis for accurate modeling include the following: ^{201}Tl and ^{86}Rb for myocardial imaging, radioiodinated hippuran, $^{99\text{m}}\text{Tc}$ -DMSA, and $^{99\text{m}}\text{Tc}$ -gluconate for renal studies, radioiodine and $^{99\text{m}}\text{TcO}_4^-$ for thyroid, salivary gland, and stomach imaging, ^{75}Se -selenomethionine for pancreas and parathyroid imaging, ^{131}I -labeled rose bengal and $^{99\text{m}}\text{Tc}$ -labeled iminodiacetic acid (IDA) compounds for hepatobiliary studies, ^{131}I -labeled iodocholesterol and ^{125}I -labeled fibrinogen (4).

UTILIZATION OF RADIOPHARMACOKINETIC DATA Dosimetry Calculations

Radiation dose calculations are essential for the development of any radiopharmaceutical. The primary need for performing these calculations is to determine the approximate risk a patient population will be exposed to as a result of their diagnostic or therapeutic study. Therefore, the proper kinetic information is needed to obtain the most accurate dosimetry calculations possible.

For proper radiation dose estimates, three data bases must be available for the calculations. First, the pharmacokinetics of the radiopharmaceutical must be known. Second, a value for the mass of distribution in the "average" man must be decided on, and lastly, the type of radiation emitted by the radionuclide with its equivalent energy deposition in tissue must be available.

The first phase of this process, the pharmacokinetics, normally is accomplished by use of various animal models. Unfortunately, due to species variation, the animal kinetic data (if extrapolated directly to humans) can be the largest single source of error in the calculation of radiation dosimetry (9). If, however, a phar-

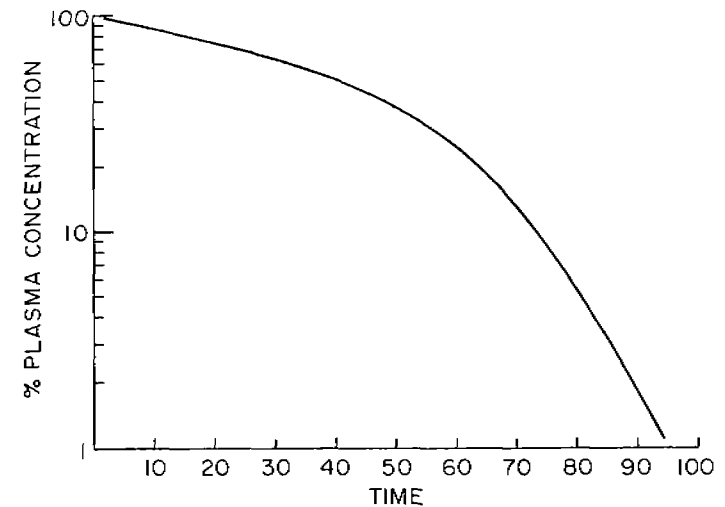

Figure 2.4. A semilogarithmic graph of drug levels in a single-compartment model that exhibits Michaelis-Menten kinetics as a function of time.

macokinetic model based on data obtained from lower animals by invasive techniques is constructed and the model is then modified to accept the compartmental masses, interconnecting pathways, and rate constants applicable to man, accurate results may be obtained.

Loberg and Buddemeyer (10) have recently demonstrated this approach with the ^{99m}Tc -IDA compounds for hepatobiliary imaging. With use of indwelling catheters for collection of blood, bile, and urine from dogs (11, 12), a four-compartment model was constructed (Fig. 2.5). Then, with use of limited blood and urine data in combination with gamma camera imaging data obtained from normal subjects, the elimination rate constants were modified to fit the human experimental data (Table 2.1).

Table 2.1.

Interspecies-related Variations in the Elimination of ^{99m}Tc -HIDA

Species	Rate Constants			
	K_{12}	K_{21}	K_{31}	K_{42}
Normal dogs	6.0	14.4	0.56	1.1
Normal man	2.0	6.0	0.49	1.6

With this type of approach, much of the ambiguity of traditional pharmacokinetics can be eliminated. Even though the data obtained from humans cannot be as complete, the relative clearance from the major organs of accumulation, blood, and urine can be externally analyzed for comparison with the previously constructed animal model.

Another advantage of this approach, in addition to the increased accuracy for dosimetry calculations, is the ability to alter the known kinetics in order to anticipate the changes in dosimetry that would occur if the drug were pharmacologically improved or if the excretion of the drug were changed due to disease. Loberg and Buddemeyer (10) demonstrated this ability with their four-compartment model of ^{99m}Tc -dimethyliminodiacetic acid (HIDA).

Several investigators (12, 13) have reported the pharmacodynamic changes seen in animal models if molecular modifications are made to the IDA compounds by alkyl substitutions on

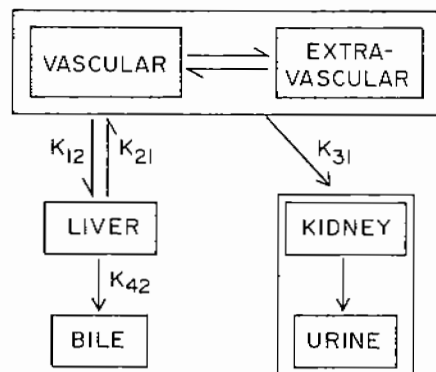

Figure 2.5. Schematic of the pharmacokinetic model for the biological distribution of ^{99m}Tc -IDA compounds.

the IDA-benzene ring. With these biological changes induced by drug modification, an increase in the liver extraction rate constant and a reduction in the renal excretion rate constant could be obtained to calculate radiation dosimetry if the proposed alkyl-substituted IDA compounds were used in man.

Radiopharmaceutical Design

In the past, radiopharmaceuticals tended to be discovered by trial and error rather than by careful design. More recently, however, radiopharmacokinetics and structure-distribution relationships (SDRs) have become important for the development of more specific and useful drugs. (See Chapter 3 for additional details.) Recent examples of radiopharmaceuticals designed in this fashion include hepatobiliary (14–19), heart (20), brain (21–23), and adrenal agents (24, 25). Of these, the kinetics of the hepatobiliary agents have received the most comprehensive study and provide the best examples for discussion.

Hepatobiliary agents have been used in nuclear medicine since 1955 when Taplin et al. (26) introduced ^{131}I -labeled rose bengal. Despite its limitations, this iodinated agent found widespread clinical use (27) as investigators strove to discover an agent with better imaging characteristics (16). In 1975, the first ^{99m}Tc -labeled derivative of IDA was introduced by Harvey et al. (28) for hepatobiliary imaging.

Since the introduction of the IDA compounds, much information regarding the pharmacokinetics of these compounds has been established.

Once the kinetic information for a radiopharmaceutical has been established, *in vitro* models can be created to test new compounds prior to their introduction and kinetic study in animals. The time, effort, and monetary advantage derived from use of this type of approach is obvious. Nunn (15) established a method of testing IDA derivatives by using high-performance liquid chromatography (HPLC).

When the radiopharmacokinetic model for the ^{99m}Tc -labeled compounds is carefully studied, several important principles can be observed. If there is an increase in the rate constant K_{12} or a decrease in the rate constant K_{31} (Fig. 2.5), hepatobiliary specificity is improved. Further, the principal determinant of hepatic transit time (which is affected by other rate constants) is the rate function K_{42} (16). With use of the kinetic model, the problem of the chemical structural requirements can be addressed. In order to achieve hepatobiliary excretion, the IDA compound must have the following: (a) diacetate substitution on the amine nitrogen, (b) an electron-pulling group substituted beta to the amine, and (c) a lipophilic group separated by substantial distance from the hydrophilic group (29).

As the different sections of the compound are changed, the effects on its pharmacokinetics can be determined. Results of these studies should lead to the development of an agent with high hepatobiliary specificity, rapid liver transit times, and good radiochemical stability. In addition, the agent should be only minimally affected by competing moieties, such as high bilirubin levels.

It is accepted that nonspecific protein binding influences the renal clearance (K_{31}), and is associated with the lipophilicity, of the drug. Nunn (15, 30) has demonstrated that para-substituted IDA compounds show the most protein binding. When the lipophilicity was compared with the renal clearance, a predictable model could be generated for para- and diortho-substituted compounds, but the renal elimination of the monoortho-substituted compounds could not be predicted *ex vivo*.

Butyl and dimethyl substitutions on the benzene ring have been used to study steric effects and the rate of hepatobiliary clearance (K_{42}) (14, 31, 32). When substitutions are made in the ortho position, changes in radiochemical composition as well as in increased hepatobiliary transit time occur as the alkyl chain length of the substitution is increased (33–35). In all cases, meta-substituted derivatives perform the best (35). Substitutions made between the ring and the amide group have no effect on *in vivo* distribution (36). If the chain length between the amide and imino nitrogen is increased, however, multiple radioactive species that adversely affect distribution are produced (14, 36).

As with many other compounds, the distribution of the IDA derivatives are affected by net electrical charge. Loberg (37) has shown that hepatobiliary clearance (K_{12} and K_{42}) is decreased, while renal clearance (K_{31}) is increased, when the molecule has a net positive charge (Fig. 2.5). Chiotellis and Varvarigou (14) demonstrated similar results with negatively charged groups or substitutes capable of hydrogen bonding.

With this radiopharmacokinetic information used in conjunction with the SDRs, a third-generation IDA compound (mebrofenin) has been described by Nunn et al. (38). This compound exhibits kinetic properties that enhance clinical imaging. (Mebrofenin is discussed in more detail in Chapter 3.)

Unfortunately, the use of radiopharmacokinetic modeling for the development of radiopharmaceuticals is not without pitfalls. First, it must be assumed or experimentally proven that the compound does not undergo metabolism *in vivo* and the observed distribution is not that of a metabolite (39). Second, as demonstrated and described by Nunn (15), protein binding and other pharmacokinetic data cannot be modeled with absolute certainty when subtle chemical changes are made. Presumably, this is due to unpredicted steric effects or radiolabeling differences. Finally, because radiopharmaceuticals are typically labeled with "no-carrier added" (nanomolar) radionuclides, it is difficult or impossible to directly determine the structure of the resultant compound and isolate a single radiochemical for injection (34).

Diagnosis

The primary function of nuclear medicine in the medical community is the diagnosis of functional abnormalities in various organ systems. This diagnosis is accomplished by review of serial images of the uptake and clearance of a radiopharmaceutical or by review of a static image in order to screen for functional homogeneity. With few exceptions, all diagnostic procedures in nuclear medicine are performed by observing the *in vivo* pharmacokinetics of the radiopharmaceutical. With use of the IDA model (Fig. 2.5), the kinetics of a normal and abnormal study can be discussed. If liver function is normal, rapid accumulation (2–3 minutes) of the IDA compound in the liver (K_{12}), visualization of the biliary system (K_{42}) within 10–15 minutes, and activity in the gallbladder and duodenum 15–30 minutes after injection should be seen (Fig. 2.6).

Abnormal function can be observed in a variety of ways. The most common indications for the use of the IDA compounds are to rule out acute cholecystitis or bile duct obstruction. If there is an obstruction in the common bile duct (Fig. 2.7), clearance of IDA from the blood (K_{12}) and hepatobiliary clearance (K_{42}) may be fairly normal. The clearance of the bile out of the common duct will be impeded, however, resulting in increased transit time and an abnormal scan. If the patient has a high bilirubin level, the radiopharmaceutical and the bilirubin will compete for hepatocyte function. The result will be a decreased K_{12} and an increased K_{31} . If the patient has severe liver disease, K_{12} and K_{42} are decreased and K_{31} is increased. In short, the actual radiopharmacokinetics are the phenomenon observed during a nuclear medicine procedure.

Another example of diagnosis based on kinetics is the radionuclide renogram. The distribution and kinetics of radioiodinated *o*-iodohippuric acid (OIH) is a six-compartment model (40) too complex to present in detail in this chapter. The normal kinetics observed during

the scanning procedure can be described, however. The normal plasma clearance half-time of OIH is about 30 minutes, with the peak kidney activity occurring 3–5 minutes after intravenous injection. During the next 10–15 minutes, the OIH is cleared from the kidneys in an exponential fashion (41). In order to obtain proper data, images are normally collected every 30 seconds for 30 minutes, and the information is stored for the construction of functional curves (Fig. 2.8). Abnormal renal function will cause a delay in peak kidney activity, a delay in visualization of bladder activity, and/or an abnormal clearance curve (Fig. 2.9).

Pharmacological Intervention

In addition to disease or observed functional abnormalities, certain drugs can cause alterations in the observed radiopharmacokinetics (42). For more information on this subject, see Chapter 10.

CONCLUSIONS

Practical radiopharmacokinetics (i.e., the observation of *in vivo* kinetics) has been the basis of nuclear medicine since its inception. The clinician's knowledge of normal drug kinetics with allowable variance is the method that is still used today for functional diagnosis. It was not until 1979 that Wolf et al. (43) introduced the term "radiopharmacokinetics" to describe the mathematical modeling of radiolabeled drugs.

Radiopharmacokinetic research has the potential for improving diagnostic roles and dosimetry calculations as well as the design and evaluation of radiopharmaceuticals. To date, the most significant realization of this potential has been in improved diagnostic techniques and dosimetry calculations. Due to the potential problems cited previously, radiopharmaceutical design based on radiopharmacokinetic modeling has been disappointing. With the introduction of new analytical tools, however, this avenue may soon prove its potential.

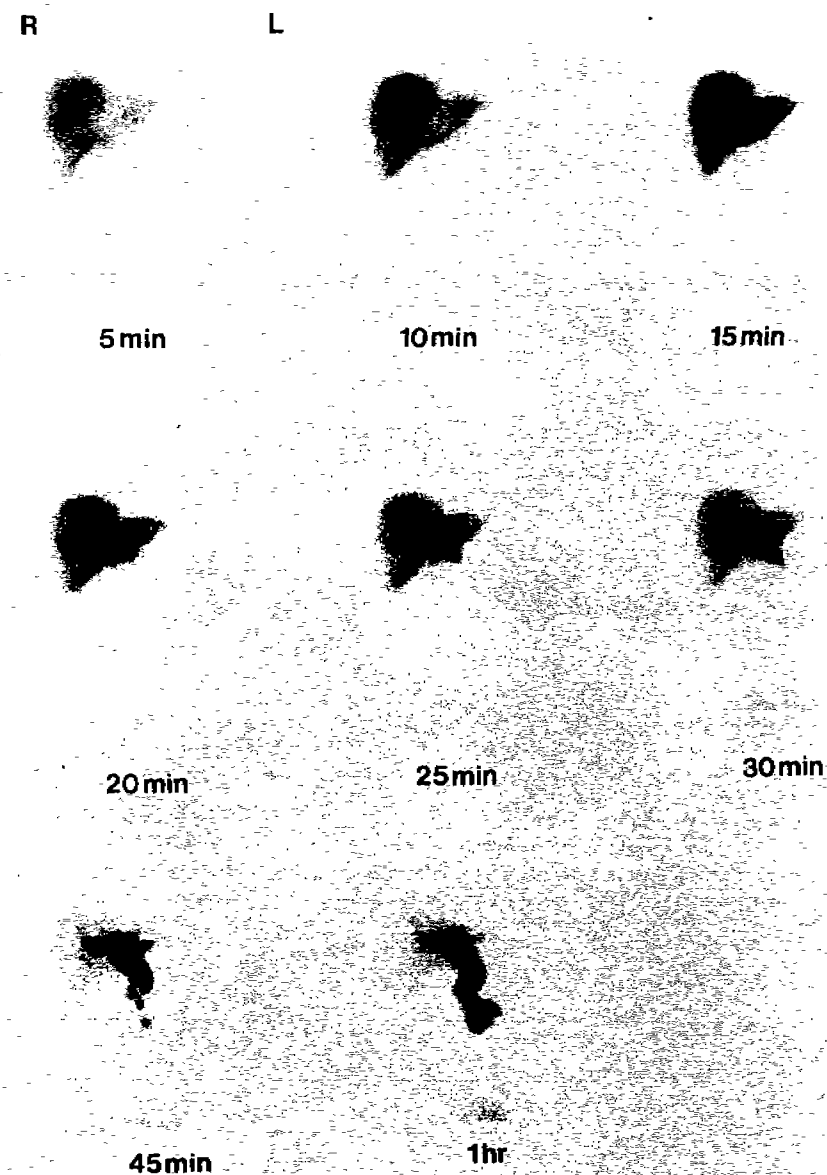

Figure 2.6. A normal hepatobiliary scan performed with ^{99m}Tc -disofenin. There is prompt uptake of the drug in the hepatic parenchyma, with visualization of the gallbladder and the duodenum within 25 minutes of injection.

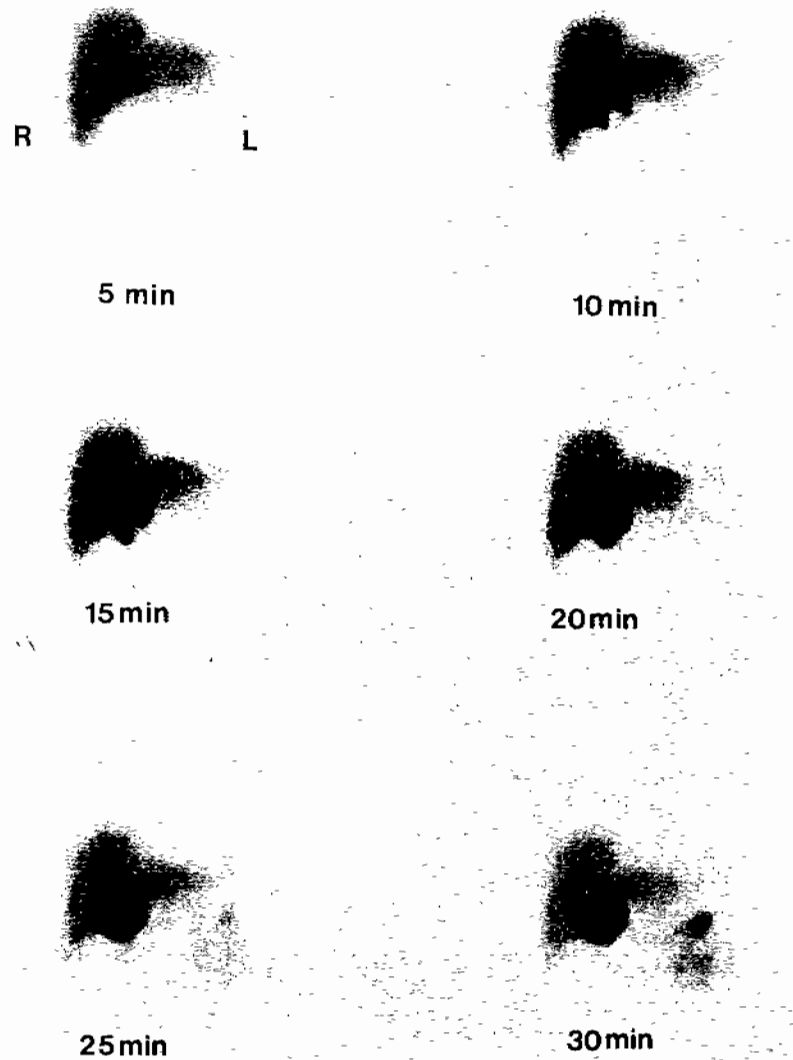

Figure 2.7. An abnormal hepatobiliary scan performed with ^{99m}Tc -disofenin. There is prompt uptake of the drug, but the gallbladder is not visualized (possible acute cholecystitis), and there is persistent activity in the common bile duct (possible partial obstruction). In addition, activity is seen in the region of the stomach, which suggests duodenal-gastric reflux.

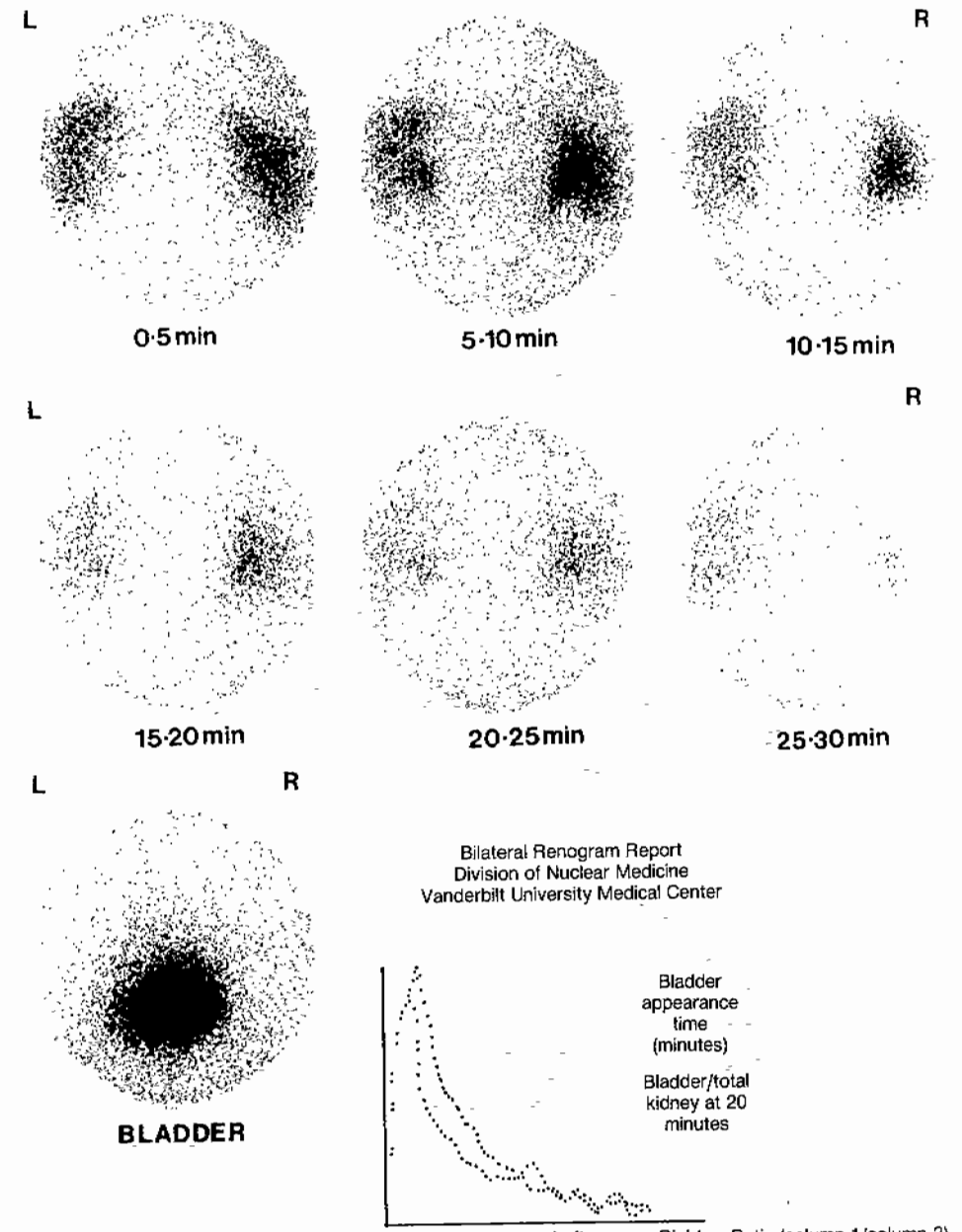

Figure 2.8. A normal bilateral renogram performed with o - ^{131}I iodohippurate. The time to peak was 3.0 minutes and 3.7 minutes for the left and the right kidney, respectively, with time to washout being 4.0 and 5.3 minutes, respectively (see insert for curve).

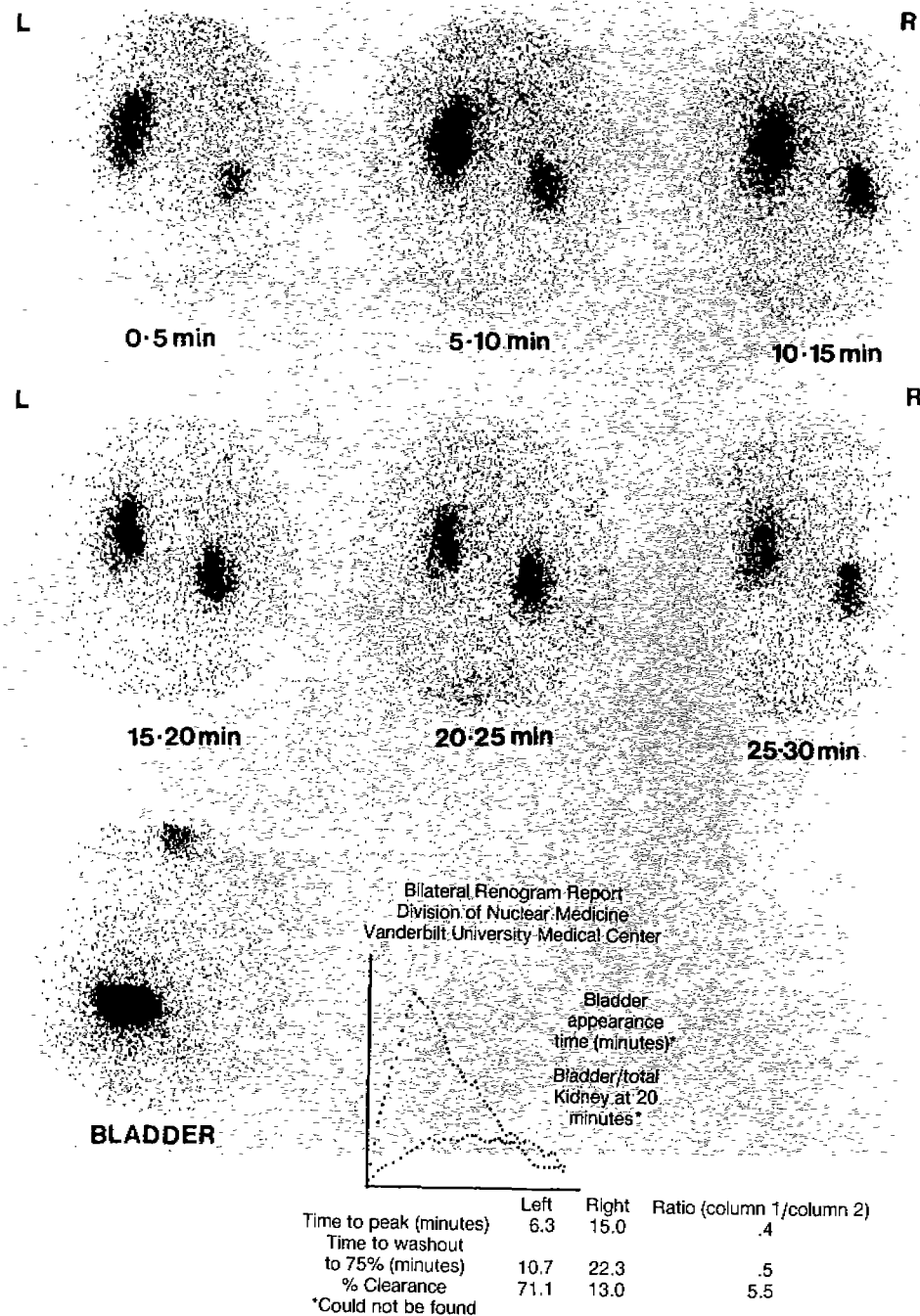

Figure 2.9. An abnormal bilateral renogram performed with *o*-[¹³¹I]iodohippurate. The time to peak was 6.3 minutes for the left kidney and 15.0 minutes for the right kidney, with clearance times being 10.7 and 22.3 minutes, respectively. This represents a bilateral decrease in function (on the right to a greater extent than on the left).

REFERENCES

- Gibaldi M, Perrier D: *Pharmacokinetics*. New York, Marcel Dekker, 1975, pp 1-43.
- Wagner JG: *Biopharmaceutics and Relevant Pharmacokinetics*. Hamilton, IL, Drug Intelligence Publications, 1971, pp 237-241.
- Kruger-Thiemer E: Pharmacokinetics. In van Rossum JM (ed): *Kinetics of Drug Action*. New York, Springer-Verlag, 1977, pp 62-163.
- Wellman HN, Appeldorn CR: A kinetic approach to the mechanisms of localization of radiotracers. In Colombetti LG (ed): *Principles of Radiopharmacology*. Boca Raton, FL, CRC Press, 1979, pp 5-26.
- Gibaldi M, Perrier D: *Pharmacokinetics*. New York, Marcel Dekker, 1975, pp 45-96.
- Saha GB, Boyd CM: Pharmacokinetic analysis of ^{99m}Tc-radiopharmaceutical data in humans by two compartmental model. *Int J Nucl Med Biol* 9:126-128, 1982.
- Gibaldi M, Perrier D: *Pharmacokinetics*. New York, Marcel Dekker, 1975, pp 215-228.
- van Rossum JM, van Ginneken CAM, Henderson PT, et al: Pharmacodynamics of biotransformation. In van Rossum JM (ed): *Kinetics of Drug Action*. New York, Springer-Verlag, 1977, pp 125-167.
- Smith EM: General considerations in calculations of the absorbed dose of radiopharmaceuticals used in nuclear medicine. In Cloutier RJ, Edwards CL, Snyder WS (eds): *Medical Radionuclides Dose and Effects*. Oak Ridge, TN, USAEC, 1970, 17-31.
- Loberg MD, Buddemeyer EU: Application of pharmacokinetic modeling to the radiation dosimetry of hepatobiliary agents. In Watson EE, Schlafke-Stelson AT, Coffey JL, et al (eds): *Third International Radiopharmaceutical Dosimetry Symposium*. Oak Ridge, TN, USAEC, 1982, 318-332.
- Ryan J, Cooper M, Loberg MD, et al: Technetium-99m-labeled *N*-(2, 6-dimethylphenylcarbamoylmethyl) iminodiacetic acid (^{99m}Tc HIDA): a new radiopharmaceutical for hepatobiliary imaging studies. *J Nucl Med* pp 18:997-1004, 1977.
- Harvey E, Loberg MD, Ryan J, et al: Hepatic clearance mechanism of ^{99m}Tc HIDA and its effect of quantitation of hepatobiliary function. *J Nucl Med* 20:310-313, 1979.
- Wistow BW, Subramanian G, Van Heertum RL, et al: An evaluation of ^{99m}Tc labeled hepatobiliary agents. *J Nucl Med* 18:455-461, 1977.
- Chiotellis E, Varvarigou A: ^{99m}Tc labeled *n*-substituted carbamoyl iminodiacetates: relationship between structure and biodistribution. *Int J Nucl Med Biol* 7:1-7, 1980.
- Nunn A: Structure-distribution relationships of radiopharmaceuticals correlation between the reversed-phase capacity factors for ^{99m}Tc phenylcarbamoylmethyliminodiacetic acids and their renal elimination. *J Chromatogr* 255:91-100, 1983.
- Chervu LR, Nunn AD, Loberg MD: Radiopharmaceuticals for hepatobiliary imaging. *Semin Nucl Med* 12:5-17, 1982.
- Hunt FC, Maddalena DJ, Wilson JG: Technetium-99m benzimidazolyl iminodiacetic acid hepatobiliary radiopharmaceuticals: structure biodistribution studies. *Int J Nucl Med Biol* 11:219-223, 1984.
- Vera DR, Krohn KA, Stadnick RC, et al: Tc-99m galactosylglycoalbumin: in vitro characterization of receptor-mediated binding. *J Nucl Med* 25:779-787, 1984.
- Kato-Azuma M: Lipophilic derivatives of ^{99m}Tc (Sn) pyridoxylidene-phenylalanine: a structure distribution relationship (SDR) study on technetium-99m complexes. *Int J Appl Radiat Isot* 33:937-944, 1982.
- Deutsch E, Bushong W, Glavan KA, et al: Heart imaging with cationic complexes of technetium. *Science* 214:85-86, 1981.
- Kung HF, Molnar M, Billings J, et al: Synthesis and biodistribution of neutral lipid-soluble ^{99m}Tc complexes that cross the blood-brain barrier. *J Nucl Med* 25:326-332, 1984.
- Sokoloff L, Reivich M, Kennedy C, et al: The (14C) deoxyglucose method for the measurement of local cerebral glucose utilization: theory, procedure, and normal values in the conscious and anesthetized albino rat. *J Neurochem* 5:897-916, 1977.
- Heiss WD, Pawlik G, Herholz K, et al: Regional kinetic constants and cerebral metabolic rate for glucose in normal human volunteers determined by dynamic positron emission tomography of (18F)-2-fluoro-2-deoxy-D-glucose. *J Cereb Blood Flow Metab* 2:212-223, 1984.
- Wieland DM, Manager TJ, Inbasekaran MN, et al: Adrenal medulla imaging agents: a structure-distribution relationship study of radiolabeled aralkylguanidines. *J Med Chem* 27:149-155, 1984.
- Knapp FF, Ambrose KP, Callahan AP: The effect of structural modifications on the adrenal uptake of steroids labeled in the side chain with ^{125m}tellurium. *J Nucl Med* 21:258-263, 1980.
- Taplin GV, Meredith OM, Kade H: The radioactive ¹³¹I tagged rose bengal uptake excretion test for liver function using external gamma ray scintillation counting techniques. *J Lab Clin Med* 45:655-678, 1955.
- Winston MA, Blahd WH: I-133 rose bengal imaging techniques in the differential diagnosis of jaundiced patients. *Semin Nucl Med* 2:167-175, 1972.
- Harvey E, Loberg MD, Cooper MJ: Tc-99m HIDA: a new radiopharmaceutical for hepatobiliary imaging. *J Nucl Med* 16:533, 1975.
- Loberg MD, Nunn AD, Porter DW: Development of hepatobiliary imaging agents. In Freeman LM, Weissman MS (eds): *Nuclear Medicine Annual 1981*. New York, Raven Press, 1981, pp 1-33.
- Nunn AD: In: *Proceedings of the 3rd International Symposium on Radiopharmaceutical Chemistry*. St Louis, CV Mosby, 1980.
- Molter M, Kloss G: Properties of various IDA derivatives. *J Labelled Compd Radiopharm* 18:56-58, 1981.
- Van Wyk AJ, Fourie PJ, Van Zyl WH, et al: Synthesis of five new ^{99m}Tc-HIDA isomers and comparison with ^{99m}Tc-HIDA. *Eur J Nucl Med* 4:445-448, 1979.

33. Fonda U, Pedersen B. Tc-99m-diethyl HIDA. A contribution to the study of its structure. *Eur J Nucl Med* 3:87-89, 1978.
34. Nicholson RW, Herman KJ, Shields RA, et al: The preparation and composition of HIDA. *Eur J Nucl Med* 5:313-317, 1980.
35. Nunn AD, Loberg MD: Hepatobiliary agents. In Spencer RP (ed): *Radiopharmaceuticals: Structure-Activity Relationships*. New York, Grune & Stratton, 1981, pp 539-548.
36. Fields AT, Porter DW, Callery PS, et al: Synthesis and radiolabeling of technetium radiopharmaceuticals based on *n*-substituted iminodiacetic acid: effect of radiolabeling conditions on radiochemical purity. *J Labeled Compd Radiopharm* 15:387-399, 1978.
37. Loberg MD: Radiolabeled drug analogs based on *n*-substituted iminodiacetic acid. In Heindel ND, Burns DH, Honda T (eds): *The Chemistry of Radiopharmaceuticals*. New York, Masson Publishing, 1978, pp 191-204.
38. Nunn AD, Loberg MK, Conley RA: A structure-distribution-relationship approach leading to the development of ^{99m}Tc-mebrofenin: an improved cholescintigraphic agent. *J Nucl Med* 24:423-430, 1983.
39. Eckelman WC, Volkert WA: In vivo chemistry of ^{99m}Tc-chelates. *Int J Appl Radiat Isot* 33:945-951, 1982.
40. Delucia R, Lara PF, Valle LB, et al: Distribution and kinetics of hippuran ¹³¹I in rats. *Acta Physiol Lat Am* 31:235-239, 1981.
41. Saha GB: *Fundamentals of Nuclear Pharmacy*, ed 2. New York, Springer-Verlag, 1984, pp 228-236.
42. Hladik WB, Nigg KK, Rhodes BA: Drug-induced changes in the biological distribution of radiopharmaceuticals. *Semin Nucl Med* 12:184-218, 1982.
43. Wolf W, Manaka R, Young D, et al: Nuclear pharmacology/radiopharmacokinetics. A new dimension of radiopharmacy/nuclear medicine. In Sodd VJ, Hoogland DR, Allen DR, et al (eds): *Radiopharmaceuticals II*. New York, Society of Nuclear Medicine, 1979, p 405.

3

Biodistribution and Structure in Radiodiagnostics*

Ned D. Heindel and Natalie Foster

A major objective of modern productive drug discovery is uncovering the quantitative relationships between a set of organic compounds and their pharmacological potencies. Academic and corporate pharmaceutical development groups employ the underlying structural correlates of molecules—compared in a standard biological assay—as predictive guides to dictate the synthesis of the optimally potent member of a series. Although there are several quantitative structure-activity relationships (SARs), the most widely exploited system is that developed by Hansch (1). Formulated from pharmacological empiricism, a molecular-level view of transmembrane passage by small molecules, and enlightened intuition, the Hansch method has been tested experimentally in several hundred sets of drug candidates and has become a cornerstone of drug discovery. Several key reviews of its utility have appeared (2, 3).

When the Hansch hypothesis is expressed as an equation, it may take several forms; the following is one of the more common:

$$\log \frac{1}{C} = -k_1(\log P)^2 + k_2(\log P) + \rho\sigma + k_3E_s + k_4$$

This equation states that there is a relationship within a series of compounds of the measured concentration to produce a defined biolog-

ical effect (*C*) to the partition coefficient (*P*) of any given member between a lipid and an aqueous phase, a polar electronic factor ($\rho\sigma$), a steric parameter (E_s), and a constant (k_4). Simply stated, drug effects relate to membrane partitioning, polarity, and the size of the molecule.

In the full form of the Hansch equation, not all terms actually are as equally important. Often, $\log P$ and/or $(\log P)^2$, where *P* is the partition coefficient measured between octanol and saline layers, shows a more significant correlation with the biological potency than do the other terms. For example, the activity of a series of alcohols as inhibitors of *Staphylococcus aureus* may be expressed as $\log (1/C) = 0.67(\log P) + 0.07$, with a correlation coefficient of 0.964 (4). The data from a study of the localization of fourteen arylboronic acids in mouse brains fit the expression $\log (1/C) = -0.53(\log P)^2 + 2.47(\log P) - 1.05$, with a correlation coefficient of 0.915 (5). Correlated in a simple bioassay, electronic and steric factors often appear less important within a limited set of similar structures. The relative solubility of a drug for lipid or blood phases (*P*) constitutes the major factor not only in potency but also in transport and/or distribution.

Quantitative SARs have made the discovery of therapeutic drugs easier for more than two decades but have been applied to imaging radiopharmaceuticals only recently. In the development of radiodiagnostics, the goal is not enhancing therapeutic action but rather optimizing target site delivery. Wieland has called this objective a structure-distribution relationship

* This work was supported, in part, by grants from the Elsa U. Pardee and W. W. Smith Foundations to Ned D. Heindel and by PHS Grant CA31426 from the National Cancer Institute, DHHS, to Natalie Foster.

(SDR) and has pointed out that often there is a marked parallel between the SAR in pharmacologically active agents and the SDR of a radiolabeled analog (6). Several radiopharmaceutical research groups have recently shown that with use of a Hansch-like approach, in vivo biodistribution can be correlated with structure within a molecular set (7, 8).

Most of the current clinically successful radiopharmaceuticals are the products of enlightened serendipity. Those investigators who have searched for new radiopharmaceuticals have often entered the field from classical medicinal chemistry and are attuned to using therapeutically active agents as likely models on which to base new imaging candidates. There are several instances in which compounds known to produce a biological effect in a target tissue concentrate within that tissue to a sufficient degree to permit imaging (when these substances bear a γ - or positron-emitting radiotracer). Counsell and Ice (9) called the application of this concept the "pharmacological approach" to radiopharmaceutical design. Others, however, have cautioned against assuming that simply because a pharmaceutical produces a biological effect in a specified biological tissue, its concentration in that tissue is elevated above that of any proximal background tissues (10). This note of caution notwithstanding, radiolabeled small molecules such as drugs, natural metabolites, and enzyme inhibitors have been a fruitful class for discovery of valuable radiodiagnostics.

The application of quantitative structure-distribution correlations is likely to make future radiopharmaceutical development much more effective, but it is unlikely to be applicable to all imaging diagnostics. Fundamentally, agents may be divided into two groups on the basis of their mechanism of localization: those agents that demonstrate true chemical avidity for the target tissue and those agents that partition by physical processes. It is necessary to understand these differing mechanisms in order to apply successfully the quantitative structure-distribution theory to the design of potential imaging agents.

A RATIONAL GROUPING OF RADIOPHARMACEUTICALS

Substrate-specific Agents

In a modern classification system for radiopharmaceuticals, which is merely the most recent of a number of proposed codifications, the pharmacologically derived agents and receptor-binding drugs are referred to as substrate specific (11). These agents participate in definite chemical reactions or in specific ligand-substrate binding within the target locus. Fatty acids for heart imaging, carbohydrate analogs for brain or tumor imaging, steroids for estrogen or androgen receptor tissues, and a plethora of enzyme inhibitors for delineation of nonubiquitous enzyme sites—when converted to radiolabeled analogs—constitute the substrate-specific class of radiopharmaceuticals (see Table 3.1).

An *isotopically substituted biochemical*, most often bearing a ^{14}C for a native ^{12}C , can track a metabolic pathway and then image anatomical loci known as targets for that biochemical. For example, the incorporation of amino acids into pancreatic produced digestive enzymes provides a well-characterized metabolic pathway, and the use of L- ^{14}C tryptophan (and other ^{14}C amino acids) for pancreas imaging is a derivative development (12).

When the agent employed is not a native biochemical but a close structural analog capable of serving as an *enzyme substrate* or inhibitor, there can still be marked target uptake in tissue in which enzymes utilizing that analog are found. *m*- ^{131}I iodobenzylguanidine (^{131}I -mIBG) (Fig. 3.1) was proposed as an adrenomedullary imaging agent because it represented a structural approximation of aralkylguanidine known to display antiadrenergic effects (13). Recent evidence shows that ^{131}I -

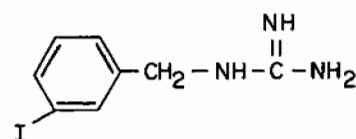

Figure 3.1. Structure of *m*- ^{131}I iodobenzylguanidine (mIBG).

Table 3.1.

Classes of Radiopharmaceuticals*

<i>Substrate specific</i> †	
Isotopically substituted biochemical	^{14}C palmitic acid
	^{14}C glucose
Metabolic trapping	2-deoxy-2- ^{18}F fluoro-D-glucose
Enzyme inhibitor or enzyme substrate	^{14}C isoxazole
	6- ^{131}I iodomethyl-19-norcholesterol (?)
	^{75}Se selenomethionine (?)
Receptor-binding biochemical or drug	Steroids
	Adrenergic blocking agents
	Cholinergic blocking agents
Antibodies to tumor-associated antigens	CEA antibody
<i>Substrate nonspecific</i> ‡	
Diffusion	$^{99\text{m}}\text{TcO}_4^-$ for brain tumor imaging
	^{133}Xe and $^{81\text{m}}\text{Kr}$ for lung ventilation studies
Compartmental space	$^{99\text{m}}\text{Tc}$ -DTPA for ECF measurements
	$^{99\text{m}}\text{Tc}$ -labeled RBC for red cell volume
	^{131}I -labeled human serum albumin for plasma volume
Capillary blockade and cell sequestration	$^{99\text{m}}\text{Tc}$ -labeled macroaggregated albumin for regional perfusion studies
	Damaged $^{99\text{m}}\text{Tc}$ -labeled RBC for splenic sequestration studies
Phagocytosis	$^{99\text{m}}\text{Tc}$ -labeled sulfur colloid for phagocytic function measurements
	$^{99\text{m}}\text{Tc}$ -labeled antimony sulfur colloid for lymphoscintigraphy

* From W. C. Eckelman and R. C. Reba: The classification of radiotracers. *J. Nucl. Med.* 19:1179-1181, 1978, with permission of the Society of Nuclear Medicine.

† The substrate must participate in a definite chemical reaction or in a definite ligand-substrate interaction.

‡ The compound does not participate in a specific chemical reaction.

mIBG has a similar uptake and retention mechanism to that of norepinephrine (14). The rationale for use of labeled enzyme substrates or inhibitors, usually tagged with radiohalogens, has been a valuable design concept in radiopharmaceutical science.

A few circumstances are known in which the radiotracer is scavenged from the blood and trapped within a target tissue as a metabolite, which thereby establishes a concentration of nuclide against the blood gradient. This *metabolic trapping* has been observed for 2-deoxy-D- ^{14}C glucose and for the clinically useful 2-deoxy-2- ^{18}F fluoro-D-glucose, both of which experience the biotransport of glucose but become trapped within the cell apparently as the nonmetabolizable 6-phosphates (15). The ^{18}F sugar, with its positron-emitting fluorine nuclide, allows a tomographic visualization of regions of high glucose uptake: metabolically active brain, tumors, and functioning well-perfused myocardium (16).

The designation of a specific radiopharmaceutical as a *receptor-binding biochemical* must, of necessity, be somewhat arbitrary in that undoubtedly many of those agents whose partitioning mechanisms class them as enzyme inhibitors and/or substrates or as metabolically trapped tracers also experience a specific ligand-receptor interaction in vivo. It is, however, the prime objective of the receptor-binding class of radiopharmaceuticals to probe only the binding phase of the receptor action.

Typical receptor densities vary, but the concentration of α -adrenoceptors in the heart is indicated in femtomoles (10^{-15} moles) per milligram, while the concentration of muscarinic cholinergic receptors is indicated in picomoles (10^{-12} moles) per milligram of protein. Similarly, binding avidities of ligands can vary widely but for most pharmaceuticals are in the 10^8 - 10^{10} M^{-1} range. Low receptor densities and high binding affinities dictate that candidate imaging radiopharmaceuticals must be of high purity and high specific activity and must contain negligible concentrations of non-radiolabeled contaminants competing for these receptor loci. Ultimate image quality appears to depend on high specific activity (17, 18).

Special radiolabeling methods and chromatographic purification techniques have been developed to produce these high-specific-activity products. Choice of suitable radionuclide for attachment to a potential receptor-spe-

cific imaging diagnostic has been a major concern. Prior research in radioimmunoassay development had shown that the substitution of halogen (usually ^{125}I) for hydrogen seldom negated the utility of the modified tracer as an *in vitro* probe of an analyte concentration. Although *in vivo* receptors are expected to be more complex and more demanding of spatial geometry and matched lipophilicity, the demonstration that radiohalogenated estrogens concentrate in breast tumors and radiohalogenated dopamine antagonists display favorable brain uptake has convinced most radiopharmaceutical investigators that the halide-for-hydrogen substitution can be successful (19, 20).

In the search for synthetic models to be labeled as imaging diagnostics, the usual procedure has been to evaluate first the tritium-labeled candidates *in vitro* by competitive binding assays performed on isolated receptor protein. In theory, the compound with the highest binding avidity should constitute the best *in vivo* candidate (after tagging with a radiohalogen) for imaging that receptor system. The use of tritiated compounds with isolated receptor preparations allows avoidance of extensive screening in animals which would otherwise be required. A recent editorial points out how the use of *in vitro* binding data on tritiated compounds (haloperidol and spiroperidol) can lead (and has led in at least one instance) to incorrect conclusions about the relative site-directed behavior *in vivo* (21). Several explanations have been advanced; one possibility is a differential metabolic exchange of tritium from the ligand. Despite this caveat, it seems certain that extrapolations from high-affinity, tritium-labeled ligands tested *in vitro* to radiohalogenated candidates probed *in vivo* will continue to be made.

Unfortunately, for reasons to be discussed shortly, no radiopharmaceuticals containing metal ion nuclides have yet demonstrated receptor-specific uptake *in vivo*. High-specific-activity radiopharmaceuticals should, in theory, be more readily obtainable by complexation of imaging candidates to cationic radionuclides such as indium, gallium, and technetium than by radiohalogenation with ^{18}F , ^{123}I , ^{131}I , ^{77}Br , or other suitable halogens. Most metallic

radionuclides are conveniently available on site at high specific activities as eluants from generators and, on chelation to a carrier ligand, are readily purified from unbound tracer.

Perhaps the ultimate in the substrate-specific class of radiodiagnostics will be those based on labeled *antibodies* raised to target associated antigens. The potential antigens can be tumor markers, normal organ-associated proteins such as cardiac myosin, cocci, or other bacteria, or hormonal regulators such as human chorionic gonadotropin. Antibodies can be raised as the classic polyclonals or may be the monoclonal products of contemporary hybridoma technology. Radionuclides can be the halogens (usually ^{131}I) or metal ions (such as $^{99\text{m}}\text{Tc}$, ^{111}In , or ^{67}Ga) chelated to ligands attached to the IgG backbone. In two recent articles, the background and the clinical promise of this emerging field of radioimmunoimaging have been reviewed (22, 23).

Although the most significant application of labeled antibodies currently is in tumor detection in animal models and humans, impressive uptakes of a $^{99\text{m}}\text{Tc}$ -labeled antibacterial antibody in an endocarditis lesion and of ^{131}I -, ^{111}In -, and $^{99\text{m}}\text{Tc}$ -labeled antimyosin fragments (Fab) in acute myocardial infarctions indicate that antibody transport of nuclides will have far wider diagnostic possibilities than just tumor imaging (24, 25). This area, however, is too nascent to yield quantitative structure-distribution studies, but several conclusions do seem possible. Nonspecific targeting of the labeled antibodies and high blood background levels can be partially overcome by computer enhancement through subtraction of the nontarget activity with a dual-tracer technique. Furthermore, smaller antibody fragments (Fab) produced by papain digestion of the original IgGs often retain target specificity, reduce the nonspecific binding, and provide a more rapid blood background clearance. Since more than 50% of the publications in 1983 on new tumor-seeking radiopharmaceuticals dealt with antibody transport, analogs within this classification of site-directed tracers seem destined to increase markedly.

Intuitively, one expects that all the substrate-specific classes (see Table 3.1) might be ame-

nable to quantitative structure-distribution correlations in a Hansch-style approach, with the possible exception of labeled antibodies and macromolecules. The labeled small molecules can take part in definite chemical reactions or engage in a specific molecule-receptor binding and therefore should be sensitive to the same factors that Hansch identified in the quantitative SAR studies of therapeutic pharmaceuticals, i.e., lipophilicity, electronic polar factors, and molecular size.

Substrate-nonspecific Agents

Substrate nonspecific agents do not require chemical events to provide attachment to the ultimate delivery site. In fact, no technetium chelate has yet been shown to engage in substrate-specific binding to a receptor protein, although many attempts to develop such agents have been made (26, 27). Nevertheless, such radiopharmaceuticals—in particular $^{99\text{m}}\text{Tc}$ chelates—may have a biodistribution that is markedly sensitive to relative lipid-versus-blood solubility and for that reason may display an SDR that correlates with either the *P* term of the Hansch equation or with a quantity derived from it.

The net elimination patterns of radiopharmaceuticals are often viewed as a competition between the renal and hepatobiliary systems. The factors determining biliary versus urinary excretion of agents are not clearly definable, but four properties—polarity, molecular size, molecular weight, and molecular structure—are most influential (28). The first breakthroughs in the application of quantitative SDRs to radiopharmaceuticals have come with those agents that can evaluate the excretory organs, presumably because the Hansch partition coefficient—a paramount factor in drug transport—is exceedingly sensitive to the same four factors that dictate excretion pathway.

For extensive biliary excretion to occur, a molecule seems to require a critical balance between polar and nonpolar aspects of its character. The molecular size selectivity for either urine or biliary excretion appears to be inherent in the organs themselves, and many compounds appear to have equal affinity for both routes. Those compounds cleared through the

kidney fall into three categories as a function of their mode of elimination: those that are filtered ($^{99\text{m}}\text{Tc}$ complexes of diethylenetriamine-pentaacetic acid (DTPA) and ethylenediaminetetraacetic acid (EDTA)), those that are secreted ($^{99\text{m}}\text{Tc}$ -*N,N'*-bis(mercaptoacetyl)ethylenediamine ($^{99\text{m}}\text{Tc}$ -DADS)), and those that experience filtration, secretion, and binding to the kidneys (among others, $^{99\text{m}}\text{Tc}$ complexes of mannitol, citrate, tetracycline, and dimercaptosuccinic acid (DMSA)) (26). In general, those compounds filtered through the glomerular membrane must be relatively small molecules. A modest amount of protein binding can be tolerated, but the charge on the compound is critical. For example, neutral dextran can cross the membrane, whereas dextran sulfate is completely rejected (29).

Few definite conclusions on the mechanisms of localization have been drawn, and very few predictions have been made with use of quantitative SDR, even in tightly controlled experiments. For correlation of the structure of $^{99\text{m}}\text{Tc}$ -labeled complexes to their biodistribution, the actual structure of the complex must be known, and the assumption must be made that this structure does not change *in vivo* (26, 30). Neither of these concerns is trivial, since structural studies (mass spectroscopy, x-ray diffraction) are impossible under the conditions prevailing in the solutions as administered and conclusions about structure can only be inferred from mass level experiments in which a carrier is used. Many $^{99\text{m}}\text{Tc}$ chelates used for renal studies are mixtures that have not been fully characterized chemically.

For example, the high-performance liquid chromatography (HPLC) evaluation of $^{99\text{m}}\text{Tc}$ -*N,N'*-bis(mercaptoacetyl)-2,3-diaminopropanoate ($^{99\text{m}}\text{Tc}$ - CO_2 -DADS) (Fig. 3.2) has shown the presence of two components, one with a specificity for renal excretion higher than that for *o*-[^{131}I]iodohippurate (OIH) and a second with comparable specificity but with slightly slower renal excretion kinetics (31). These two major components are thought to result from chelate ring isomerization. Knowledge of their individual molecular structures will aid in understanding how these complexes are handled by the renal tubular system, which

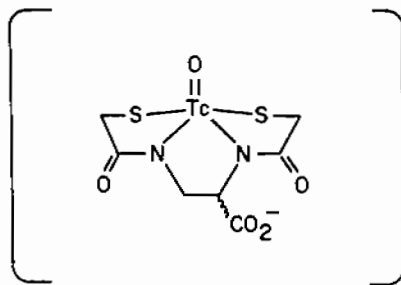

Figure 3.2. Structure of Tc-*N,N'*-bis(mercaptoacetyl)-2,3-diaminopropanoate (Tc-CO₂-DADS).

differs essentially only in the kinetics. This preparation has significantly improved parameters for evaluation of renal function with regard to ^{99m}Tc-*N,N'*-bis(mercaptoacetyl)ethylene diamine (^{99m}Tc-DADS) which has been suggested as a potential replacement for OIH. The source of the improved characteristics of the new carboxylate analog is thought to be the increased protein binding of the agent, which vastly decreases its glomerular filtration.

Another interesting aspect of the biodistribution of these mixed agents is the effect of stannous ion (often used in kits to reduce the high oxidation states of the available Tc to the lower states needed for complex formation) on the retention of the radiopharmaceutical in the renal cortex. For a series of chelating agents, an increase in divalent tin concentration causes an increased retention in the kidneys apparently by altering the permeability of the membranes (32).

EXAMPLES OF QUANTITATIVE SDR

Hepatobiliary Imaging Agents

Radiopharmaceuticals that localize within the hepatobiliary system are a noninvasive diagnostic means of evaluating many clinical problems. Unlike the excretion of many compounds by the kidney, the passage of compounds through the hepatobiliary system is an active secretory process (33). A number of generalizations regarding the properties necessary for a high level of biliary rather than kidney excretion have been proposed: a minimum molecular weight of around 500 daltons (this number is species related and may be

lower for "good" excreters like rats, dogs, and hens), conjugation, and increased lipid solubility. The molecules also should contain at least two planar lipophilic structures plus a polar group and must be protein bound (26). It is thought that classic receptor-binding mechanisms are not likely to operate because of the diverse types of compounds that seem to share the same hepatobiliary pathway; nevertheless, the development of SDRs has been possible and has become crucial to the logical design of better radiopharmaceuticals for hepatobiliary imaging.

The iminodiacetic acid (IDA) complexes of ^{99m}Tc have been successfully used as hepatobiliary agents, and a considerable body of data from which SDRs were developed has been collected. Burns et al. (7) showed that there was a linear relationship between the net biliary excretion found for ^{99m}Tc complexes of IDA derivatives and the natural log of the molecular weight divided by the charge (Fig. 3.3). Within a limited compound series, in which variations in molecular weight are obtained by simple functional substitutions (H, CH₃, I, Br, NO₂) at a site remote from the metal ion-binding locus, increases in the overall molecular weight would be expected to reflect increasing lipophilicity. Furthermore, increases in overall charge would be expected to parallel decreases in lipophilicity. Thus, for some limited series of radiopharmaceuticals the log *P* or log (octanol/saline) as employed in the Hansch equation can be approximated by log (molecular weight/molecular charge).

Nunn et al. (8) tested 33 IDA derivatives and drew correlations between physicochemical parameters, structural effects, and in vivo characteristics. They showed that lipophilicity can be used to predict protein binding and in vivo distribution of ^{99m}Tc-IDA derivatives. Their linear SDRs were used to develop a new compound with excellent properties as a cholecintigraphic agent. The resultant compound, mebrofenin (Fig. 3.4) or 3-bromo-2,4,6-trimethylphenylcarbamoylmethyliminodiacetic acid, exhibited: (a) high specificity for the hepatobiliary system, (b) rapid transit time through the hepatobiliary system, and (c) high resistance to competition from compounds

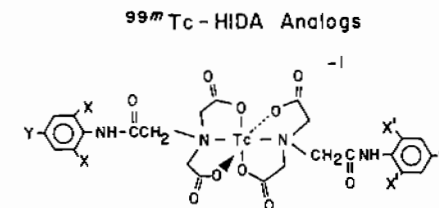

Complex ^a	X	Y	MW	Z	Ln MW/Z
A	-CH ₃	-I	935.42	-1	6.84
B	-H	-I	879.28	-1	6.78
C	-CH ₃	-Br	841.42	-1	6.73
D	-H	-NO ₂	717.50	-1	6.58
E	-H	-CO ₂ H	715.52	-3	5.47
F	-CH ₃	-H	683.60	-1	6.52
G	-H	-CH ₃	655.56	-1	6.49
H	-H	-H	627.52	-1	6.44
I	X = -H X' = -CH ₃	Y = -CO ₂ H Y' = -H	671.52	-2	5.82

^a Unless otherwise indicated X = X' and Y = Y'

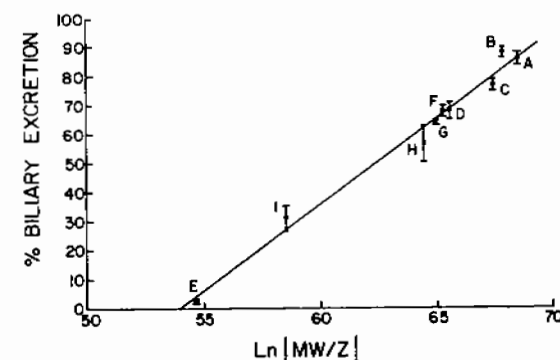

Figure 3.3. Biliary excretion of IDA analogs as ^{99m}Tc complexes in mice. MW, molecular weight; Z, charge. (From H. D. Burns et al.: Design of technetium radiopharmaceuticals. In N. D. Heindel et al. (eds.): *The Chemistry of Radiopharmaceuticals*. New York, Masson Publishing, 1978, pp. 268-289, with permission of Masson Publishing.)

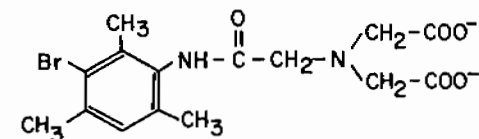

Figure 3.4. Structure of 3-bromo-2,4,6-trimethylphenylcarbamoylmethyliminodiacetic acid (mebrofenin).

such as bilirubin. In the context of the study it was shown that ortho substituents contributed less to the measured lipophilicity than the classic Hansch-approach theory had predicted. IDA derivatives with small alkyl substituents in the ortho position had faster hepatocellular transit times than did their unsubstituted counterparts.

In a study of the SDRs in ^{99m}Tc complexes of pyridoxylidenephénylalanine (Fig. 3.5), Kato-Azuma (34, 35) noted that the halogens or alkyl groups placed on phenyl ring positions on the phenylalanine moiety increased the total lipophilicity and invariably decreased the urinary excretion. Such substituents in the para position, however, delayed hepatobiliary transit, while those in the ortho position appeared to accelerate it. If both ortho and para positions were occupied by lipophilic substituents, the effect of the ortho substituent (acceleration) predominated over the effect (inhibition) of the para substituent with regard to the hepatobiliary transit. Among the three pyridoxylami-

nates studied in rats (amino acid moieties included phenylalanine, tryptophan, and 5-methyltryptophan), use of the 5-methyltryptophan derivative ($^{99m}\text{Tc}(\text{Sn})\text{-PHMT}$) (Fig. 3.6) resulted in the highest biliary excretion, lowest blood and renal retention, and the smallest urinary output. Thus, as has often been seen in structure-distribution studies of metallonucleide radiopharmaceuticals, subtle differences of structure can produce major alterations in in vivo behavior and can frustrate quantitative SDRs.

A radiohalogenated family of hepatobiliary imaging candidates, however, displayed more regular SDRs. Reiffers et al. (36) prepared five indotricarbocyanines labeled with ^{131}I in the 5-position and H, F, Cl, Br, and I in the 5'-positions (Fig. 3.7). A small change in the 5'-substituent had a pronounced effect on the liver clearance of the molecule in mice. Whether the controlling mechanism was due to steric and/or electronic effects was not obvious from the results, but a correlation between liver

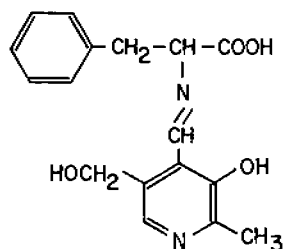

Figure 3.5. Structure of pyridoxylidenephénylalanine.

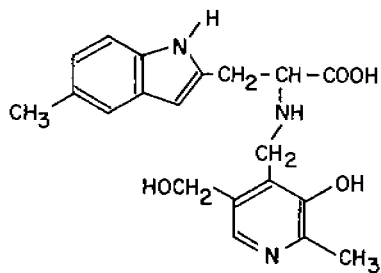

Figure 3.6. Structure of pyridoxylamine of 5-methyltryptophan.

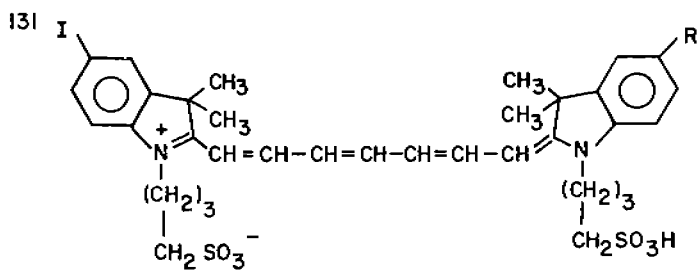

Figure 3.7. Structure of indotricarbocyanine radiolabeled with ^{131}I at the 5-position and substituted at the 5'-position.

activity 30 min postinjection and both the van der Waals radius and the Pauling electronegativity of the substituent in the 5'-position was shown. It was noted also that the more polarizable the halogen, the slower the liver clearance (Fig. 3.8).

Bone Imaging Agents

SDRs have also been studied for ^{99m}Tc bone-imaging agents. From the original reports in 1971 by Subramanian and McAfee (37) and many subsequent evaluations, the criteria for uptake have been determined. These structure-affinity relationships depend on both the processes involved in bone metabolism and the

chemical and structural configuration of the compound (38). In general, for the polyphosphate agents (pyrophosphate, tripolyphosphate, polyphosphate), uptake in bone is inversely proportional to chain length (39). Only a single phosphate moiety appears necessary for good bone uptake by candidate imaging agents, even though most currently utilized radiopharmaceuticals have more than one such function, e.g., methylene diphosphonate (MDP) and hydroxymethylene diphosphonate (HDP) (40) (Fig. 3.9). The importance of additional functional groups may lie in their ability to keep the stannous ion, which was used to reduce the pertechnetate, in solution (26).

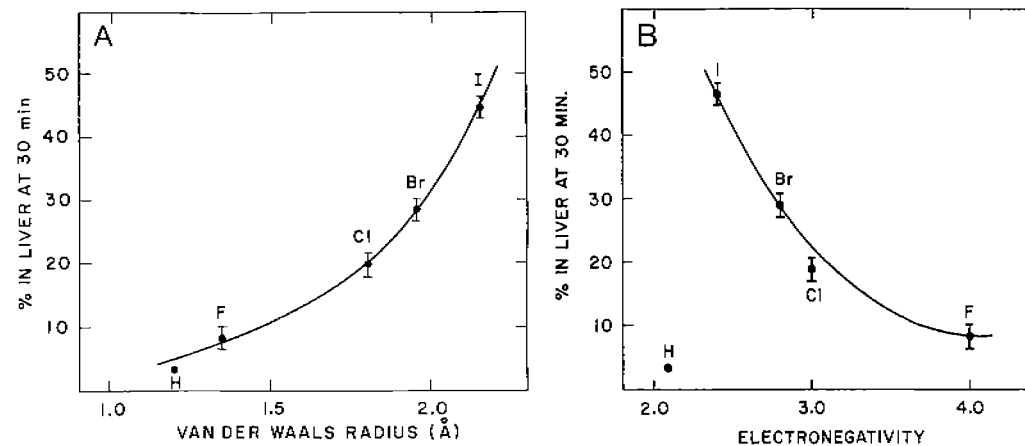
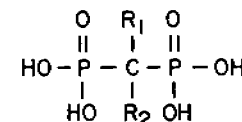

Figure 3.8. A. Correlation of the 30-min retention of the ^{131}I monohalo-bis salts in mice with the van der Waals radius of the 5-halogen substituent. B. Correlation of the 30-min retention of ^{131}I monohalo-bis salts in mice with the Pauling electronegativity of the 5-halogen substituent. (From S. Reiffers et al.: Cyclotron isotopes and radiopharmaceuticals—XXXIII. *Int. J. Appl. Isot.* 34:1383–1393, 1983, with permission of the Brookhaven National Laboratory and Pergamon Press.)



MDP (methylene diphosphonate): $R_1 = \text{H}, R_2 = \text{H}$

HEDP (hydroxyethylidenediphosphonate): $R_1 = \text{CH}_2\text{CH}_2\text{OH}, R_2 = \text{OH}$

HDP (hydroxymethylenediphosphonate): $R_1 = \text{H}, R_2 = \text{OH}$

Figure 3.9. Structure of diphosphonate ligand for ^{99m}Tc -labeled bone imaging agents.

SUMMARY

Whether it be in myocardial agents, bone-affinic compounds, estrogen receptor-specific tracers, hepatobiliary radionuclide chelates, or any of the myriad of other radioactive in vivo diagnostics, more and more investigators have been testing the principles of SDR in their search for improved radiopharmaceuticals. When the structural variations across a compound set are not extensive, a linear correlation may be observed between one or more physicochemical properties and biodistribution (7, 36). When the compound set is structurally diverse, however, it is the fortunate investigator who can make even a qualitative correlation (29, 31). In the final analysis, radiopharmaceutical researchers probe for correlations not just as an academic exercise but to assist in preparing the optimum candidate imaging agent. There have been successes (8, 34, 36) and there surely will be others, for while the application of structure-distribution studies to radiopharmaceuticals is a budding endeavor, the seed has germinated and further fruits will surely be born.

REFERENCES

- Hansch C: On the structure of medicinal chemistry. *J Med Chem* 19:1-6, 1976.
- Hansch C: A quantitative approach to biochemical structure-activity relationships. *Acc Chem Res* 2:232-239, 1969.
- Leo A, Hansch C, Elkins D: Partition coefficients and their use. *Chem Rev* 71(6):525-554, 1971.
- Lien EJ, Hansch C, Anderson SM: Structure-activity correlations for antibacterial agents on Gram-positive and Gram-negative cells. *J Med Chem* 11:430-441, 1968.
- Hansch C, Steward AR, Iwasa J: The correlation of localization rates of benzenboronic acids in brain and tumor tissue with substituent constants. *Mol Pharmacol* 1:87-92, 1965.
- Wieland DM, Brown LE, Mangner TJ, et al: Radioiodinated aralkylguanidines: synthesis and clinical potential. International Symposium on Radioiodines, Banff, Alberta, Canada, 1980, pp 22-24.
- Burns HD, Worley P, Wagner HN Jr, et al: Design of technetium radiopharmaceuticals. In Heindel ND, Burns HD, Honda T, Brady LW (eds): *The Chemistry of Radiopharmaceuticals*. New York, Masson Publishing, 1978, pp 268-289.
- Nunn AD, Loberg MD, Conley RA: A structure-distribution-relationship approach leading to the development of ^{99m}Tc -mebrofenin: an improved cholescintigraphic agent. *J Nucl Med* 24:423-430, 1983.
- Counsell RE, Ice RD: The design of organ imaging radiopharmaceuticals. In Ariens EJ (ed): *Drug Design*. New York, Academic Press, 1974, vol 6, pp 172-259.
- Andrews GA, Kniseley RM, Wagner HN Jr: (Editors remarks). In: *Radioactive Pharmaceuticals*, USAEC Publication, CONF-651111. Springfield, VA, USAEC, 1971, p 116.
- Eckelman WC, Reba RC: The classification of radiotracers. *J Nucl Med* 19:1179-1181, 1978.
- Washburn LC, Hubner KF, Sun TT, et al: ^{14}C -tryptophan, a potential agent for diagnosis of pancreatic disease using PET. *J Nucl Med* 24:P121, 1983.
- Wieland DM, Wu JL, Brown LE, et al: Radiolabeled adrenergic neuron-blocking agents: adrenomedullary imaging with ^{131}I -iodobenzylguanidine. *J Nucl Med* 21:349-353, 1980.
- Jaques S Jr, Tobes MC, Sisson JC, Wieland DM: Mechanisms of uptake and retention of meta-iodobenzylguanidine (mIBG) in the adrenal medulla. *J Nucl Med* 24:117, 1983.
- Reivich M, Alavi A, Greenberg J, et al: ^{18}F Fluorodeoxyglucose method for measuring local cerebral glucose metabolism in man: technique and results. *Prog Nucl Med* 7:138-148, 1981.
- Alavi A, Reivich M, Greenberg J, Wolf AP: Cerebral functional activity mapped with ^{18}F -2-deoxy-2-fluoro-D-glucose. In Lambrecht RM, Marcos N (eds): *Applications of Nuclear and Radiochemistry*. New York, Pergamon Press, 1982, pp 239-250.
- Eckelman WC: *Receptor-Binding Radiotracers*. Boca Raton, FL, CRC Press, 1982, vol I.
- Eckelman WC: *Receptor-Binding Radiotracers*. Boca Raton, FL, CRC Press, 1982, vol II.
- DeJesus OT, Friedman AM, Prasad A, Revenaugh JR: Preparation and purification of ^{77}Br labeled *p*-bromospiperidol for in vivo dopamine receptor studies. *J Labelled Compd Radiopharm* 20(6):745-756, 1983.
- McElvany DK, Katzenellenbogen JA, Shafer KE, et al: $^{16\alpha}\text{-}^{77}\text{Br}$ bromoestradiol: dosimetry and preliminary clinical studies. *J Nucl Med* 23:425-430, 1982.
- Tewson TJ: Radiopharmaceuticals for receptor imaging. *J Nucl Med* 24:442-443, 1983.
- Goldenberg DM: Tumor imaging with monoclonal antibodies. *J Nucl Med* 24:360-362, 1983.
- Sfakianakis GN, Deland FH: Radioimmunodiagnosis and radioimmunotherapy, 1982. *J Nucl Med* 23:840-850, 1982.
- Wahl RL, Parker CW, Philpott GW: Improved radioimaging and tumor localization with monoclonal F(ab')₂. *J Nucl Med* 24:316-325, 1983.
- Yasuda T, Leinbach RC, Khaw BA, et al: Prediction of infarct volume in patients undergoing reperfusion therapy by ^{99m}Tc -antimyosin SPECT. *J Nucl Med* 25:P20, 1984.
- Eckelman WC, Voklert WA: In vivo chemistry of ^{99m}Tc -chelates. *Int J Appl Radiat Isot* 33:945-952, 1982.
- Dannals RF, Burns HD, Marzilli LG, et al: The use of ^{99m}Tc and ^{99}Tc in the development and characterization of new radiotracers for diagnostic nuclear medicine. In Lambrecht RM, Marcos N (eds): *Applications of Nuclear and Radiochemistry*. New York, Pergamon Press, 1982, pp 127-138.
- Chervu LR, Nunn AD, Loberg MD: Radiopharmaceuticals for hepatobiliary imaging. *Semin Nucl Med* 12:5-17, 1982.
- Blaufox MD, Chervu LR: Analysis of structure-activity relationship of renal imaging agents. In Spencer RP (ed): *Radiopharmaceuticals: Structure-Activity Relationships*. New York, Grune & Stratton, 1981, pp 521-537.
- Chiotellis E, Stassinopoulou CI, Varvarigou A, Vavouraki H: Structure-activity relationships of some ^{99m}Tc labeled thioethylamino carboxylates. *J Med Chem* 25:1370-1374, 1982.
- Fritzberg AR, Kuni CC, Clingensmith WC III, et al: Synthesis and biological evaluation of ^{99m}Tc *N,N'*-bis(mercaptoacetyl)-2,6-diaminopropanoate: a potential replacement for ^{131}I *o*-iodohippurate. *J Nucl Med* 23:592-598, 1982.
- Steigman J, Chin EV, Solomon NA: Scintiphotos in rabbits made with ^{99m}Tc -preparations reduced with electrolysis and SnCl_2 : concise communication. *J Nucl Med* 20:766-770, 1979.
- Nunn AD, Loberg MD: Hepatobiliary agents. In Spencer RP (ed): *Radiopharmaceuticals: Structure-Activity Relationships*. New York, Grune & Stratton, 1981, pp 539-556.
- Kato-Azuma M: $^{99m}\text{Tc}(\text{Sn})$ -*N*-pyridoxylaminates: a new series of hepatobiliary agents. *J Nucl Med* 23:517-524, 1982.
- Kato-Azuma M: Lipophilic derivatives of $^{99m}\text{Tc}(\text{Sn})$ pyridoxylidene phenylalanine: a structure distribution relationship (SDR) study on ^{99m}Tc complexes. *Int J Appl Radiat Isot* 33:937-944, 1982.
- Reiffers S, Lambrecht RM, Wolf AP, et al: Cyclotron isotopes and radiopharmaceuticals—XXXIII. Synthesis and structural effects of selective biliary excretion of halogenated indotricarbocyanines. *Int J Appl Radiat Isot* 34:1383-1393, 1983.
- Subramanian G, McAfee JG: A new complex of ^{99m}Tc for skeletal imaging. *Radiology* 99:192-196, 1971.
- Hosain P, Wang TST: Bone imaging compounds with special reference to structure-affinity relationship. In Spencer RP (ed): *Radiopharmaceuticals: Structure-Activity Relationships*. New York, Grune & Stratton, 1981, pp 521-537.
- Jones AJ, Francis MD, Davis MA: Bone scanning: radionuclidic reaction mechanisms. *Semin Nucl Med* 6:3-18, 1976.
- Hosain P, Spencer RP, Ahlquist KJ, Sripada PK: Bone accumulation of the ^{99m}Tc complex of carbamyl phosphate and its analogs. *J Nucl Med* 19:530-533, 1978.

4

Metabolic Fate of Radiopharmaceuticals

Robert C. Jost

After absorption or intravenous injection, a drug is distributed into interstitial and cellular fluids of the body. This distribution is influenced by the various physiological factors and physiochemical properties of the drug. These include cardiac output, regional blood flow, lipid solubility, and protein binding. Drug action usually is terminated by excretion of the unchanged drug or by metabolism of the drug followed by excretion of pharmacologically active or inactive metabolites. Drugs often are nonpolar, lipid-soluble organic acids or bases that are not readily eliminated from the body. Metabolic reactions commonly result in more polar and less lipid-soluble metabolites that are more easily excreted than are the original drugs.

Metabolic reactions involving drugs have been classified as either nonsynthetic or synthetic (1). Nonsynthetic reactions include oxidation, reduction, and hydrolysis and may result in activation, change in activity, or deactivation of the parent compound. Synthetic reactions involve the conjugation of the drug or metabolite to an endogenous substance such as glucuronic acid, acetic acid, glycine, or sulfate.

Metabolic reactions are further classified as either nonmicrosomal or microsomal. Nonmicrosomal metabolic reactions include acetylation reactions, glycine and sulfate conjugations, and methylation reactions involving oxygen, sulfur, and nitrogen. In addition, nonmicrosomal enzymes are involved in the catalysis of some oxidation, reduction, and hydrolysis reactions. Nonmicrosomal enzymes are primarily found in the liver but may also occur in plasma, intestines, and red blood cells

(RBC). Microsomal enzymes are found primarily in the smooth endoplasmic reticulum of the liver and, additionally, in the kidney and gastrointestinal epithelium. Microsomal enzymes catalyze glucuronide conjugations of phenols, alcohols, and carboxylic acids as well as many oxidative reactions. These oxidative reactions include nitrogen and oxygen dealkylation, deamination of primary and secondary amines, and desulfuration. Enzymes that are collectively called mixed function oxidases are utilized in oxidative reactions of the hepatic endoplasmic reticulum. The terminal oxidase in the system is cytochrome P-450. The reactions require nicotinamide adenine dinucleotide phosphate (NADPH) as the primary electron donor and molecular oxygen.

METABOLISM OF RADIOPHARMACEUTICALS

The general metabolic reactions discussed previously also act on radiopharmaceuticals. Detailed chemical characterizations of radiopharmaceutical metabolites and metabolic pathway studies are scant, however. This lack of research into the metabolism of radiopharmaceuticals may reflect the difficulties encountered in the analysis of tracer amounts of the drugs and their metabolites. Alternatively, the generally held clinical opinion that a radiopharmaceutical need only be stable until it reaches its target organ may prevent generation of the necessary interest and funding required for these studies.

The radiopharmaceuticals used commonly in nuclear medicine may be classified into five groups:

1. Gases: ^{133}Xe and $^{81\text{m}}\text{Kr}$
2. Cations: ^{67}Ga , ^{201}Tl , ^{111}In , and $^{113\text{m}}\text{In}$
3. Anions: [^{51}Cr]chromate, [$^{99\text{m}}\text{Tc}$]pertechnetate, [^{32}P]phosphate, [^{123}I]iodide, or [^{131}I]iodide
4. $^{99\text{m}}\text{Tc}$ -labeled compounds: pyrophosphate, diphosphonates, sulfur colloid, macroaggregated albumin, serum albumin, iminodiacetic acid derivatives, gluceptate, dimercaptosuccinic acid (DMSA), and diethylenetriaminepentaacetic acid (DTPA)
5. Radiiodinated compounds: *o*-iodohippuric acid, iodomethylnorcholesterol (NP-59), fibrinogen, and serum albumin

Gases

The radioactive gases, ^{133}Xe and $^{81\text{m}}\text{Kr}$, are not metabolized and are excreted in the molecular form. The biodistribution of these gases is discussed in Chapter 1.

Cations

The cationic radionuclides used in nuclear medicine include [^{67}Ga]gallium citrate, [^{201}Tl]thallous chloride, [^{111}In] or [^{113}In]indium chloride, ^{111}In -oxine, and ^{111}In -diethylenetriaminepentaacetic acid (DTPA).

Gallium is found in group III of the periodic table below aluminum and above indium and normally is found as a trivalent cation. It has no known trace element function (2). After intravenous injection of [^{67}Ga]gallium citrate, ^{67}Ga rapidly binds to plasma proteins, especially to transferrin. It also binds to ferritin, lactoferrin, and siderophores. There is much controversy concerning the mechanism(s) of gallium uptake by tumors and inflammatory tissue. It appears that the biological behavior of gallium is closely related to ligands found in vivo and, more significantly, to the metabolic pathways of related cations (3). Unbound gallium is deposited in the bone and excreted in the urine. It has been shown that in the urine, ^{67}Ga initially occurs in citrate form (4). Also found are gallium hydrolysis products, gallium hydroxide, and gallate. In addition, 50% of the ^{67}Ga activity has been found to be retained by membrane ultrafiltration when the urine is collected and analyzed at 1 week postinjection; this retained fraction is believed to represent a

^{67}Ga -labeled protein complex of unknown nature. As is discussed in Chapter 1, radiogallium is also eliminated to some extent in the bowel.

[^{201}Tl]thallous chloride is used to measure myocardial perfusion in patients with suspected myocardial ischemia or infarction. Much evidence supports the belief that the in vivo utilization of thallium is closely related to potassium utilization. Studies in rats and dogs have demonstrated increased urinary thallium excretion with increased dietary potassium (5). It has also been shown that thallium uptake, like potassium uptake, occurs by an active transport mechanism and that once inside the cell, thallium is released at a slower rate than is potassium. The initial myocardial uptake of thallium is dependent on myocardial blood flow distribution and the extraction of thallium by the myocardium (6). Redistribution of thallium begins immediately and continues until equilibrium is reached with the circulating thallium pool (7).

Studies on the metabolic fate of ^{111}In in rats have shown that following intravenous injection of [^{111}In]indium chloride, the ^{111}In trivalent cation is bound to transferrin and not preferentially localized in any one tissue (8). It was suggested that ^{111}In is bound to connective tissue via polyanionic mucopolysaccharides.

Anions

The anionic radiopharmaceuticals are represented by sodium [^{51}Cr]chromate, sodium [$^{99\text{m}}\text{Tc}$]pertechnetate, sodium [^{32}P]phosphate, and chromic [^{32}P]phosphate suspension.

^{51}Cr in the form of sodium chromate labels RBC for use in determining red cell survival time, measuring blood volume measurements, and imaging the spleen. It is thought that the labeling mechanism probably involves diffusion of the anionic hexavalent chromium (CrO_4^-) through the red cell membrane where it is then enzymatically reduced to Cr^{3+} (9). Spontaneous elution of radioactivity occurs at a rate of more than 1% a day. The released radioactivity in the Cr^{3+} form is not capable of labeling other cells but may bind plasma proteins. Trivalent chromium is an essential trace element. It is a factor for the action of insulin

in controlling glucose metabolism. It is bound in a complex ligand known as the "glucose tolerance factor" (GTF) (10). Chromium also is found in ribonucleic acid (RNA). It is not known whether injected chromium is capable of being incorporated into GTF or RNA.

Seventy to eighty percent of the pertechnetate anion (TcO_4^-) is protein bound in plasma (11), with the majority being bound to serum albumin (12). The 20–30% that is unbound acts as a highly diffusible small molecule which can be found in many organs including the thyroid, salivary glands, gastric mucosa, and the choroid plexus of the brain. The unbound pertechnetate is removed from the blood by loss to the extracellular fluid or to specific tissue entrapment as in the thyroid. As the concentration of free TcO_4^- decreases, the equilibrium shifts to release more TcO_4^- from its protein-binding sites until equilibrium is re-established. Pertechnetate is excreted in the urine, feces, saliva, and lacrimal fluid. The administration of perchlorate (ClO_4^-) results in tissue redistribution of TcO_4^- . This result may be due to either release of TcO_4^- from plasma protein-binding sites and redistribution to extracellular spaces or a partial intracellular shift of TcO_4^- (13). In the presence of perchlorate, TcO_4^- moves into RBC.

Phosphorus is found in organic and inorganic forms in all tissues. Ninety percent of the body's phosphorus is found in bone as PO_4^{3-} in the hydroxyapatite crystal where its turnover is normally slow (14). Phosphorus also is found in nucleic acids, phospholipids, plasma, and extracellular fluids. The biological half-life ($t_{1/2}$) of ^{32}P in bone is 1155 days, and the $t_{1/2}$ for the whole body is 257 days. The biological $t_{1/2}$ for soft tissues is approximately 90 days (14). Additional information on phosphates is presented in the section of this chapter on bone imaging agents.

The metabolism of iodine has been studied extensively (15, 16) and, therefore, is not discussed in detail. Certain aspects of iodine metabolism, however, are pertinent to nuclear medicine studies.

The average daily iodine intake is approximately 150 $\mu\text{g}/\text{day}$. Degradation of thyroid hormones contributes another 70 $\mu\text{g}/\text{day}$ to this

inorganic iodine pool. Inorganic iodine circulates as iodide (I^-) until it is taken up by the thyroid where it is enzymatically oxidized to iodine (17). Thyroid uptake accounts for about 70 μg of iodine per day. The remainder is excreted through the kidney, except for small amounts excreted in the feces. Thyroid hormone synthesis is inhibited by thiourea or thioamide-type drugs (propylthiouracil, methimazole). Thyroid trapping of iodide is blocked by thiocyanates and perchlorate. Increased dietary iodine decreases the thyroid uptake of $^{131}\text{I}^-$ or $^{123}\text{I}^-$ during nuclear medicine procedures.

$^{99\text{m}}\text{Tc}$ -labeled Compounds

The use of $^{99\text{m}}\text{Tc}$ -labeled sulfur colloid for imaging the spleen, liver, and bone marrow is based on the premise that cells of the reticuloendothelial system (RES) are able to remove colloid particles from the circulation. Fixed macrophages are believed to be the primary RES cell responsible for colloid uptake. Autoradiographic techniques were unable to demonstrate $^{99\text{m}}\text{Tc}$ activity within Kupffer cells (18). Evidence that macrophages do, in fact, phagocytize $^{99\text{m}}\text{Tc}$ -labeled sulfur colloid particles, however, has come from studies that have demonstrated osmium-stained colloid particles with liver macrophages of the rat (19). This result is in contrast to the results of studies which showed that neutrophils are not labeled by phagocytosis of $^{99\text{m}}\text{Tc}$ -labeled sulfur colloid but are labeled by adhesion of colloid at their external surface (20).

Factors affecting the phagocytosis of sulfur colloid particles have been divided into (a) particle factors and (b) host factors (21). Particle factors include charge, surface characteristics (foreignness), size, and dose. Size appears to have the most influence on the biodistribution of sulfur colloid particles. With a mean particle size of 100 nm, 80–90% of the activity is seen in the liver, with 5–10% seen in the spleen and the remainder seen in the bone marrow (22, 23). Larger particles result in increased splenic uptake, whereas smaller particles localize in the bone marrow (23). Host factors include organ blood flow and reticuloendothelial cell integrity. Increased splenic uptake has been seen with malignant

melanoma (24), portal hypertension (25), and cirrhosis (21).

Noting the *in vitro* instability of sulfur colloid particles in the presence of serum, Frier et al. (26) examined the biodistribution of sulfur colloid labeled with both $^{99\text{m}}\text{Tc}$ and ^{35}S . It was found that the biodistribution of the two labels differed considerably. With $^{99\text{m}}\text{Tc}$ -labeled sulfur colloid, liver uptake was more than 80% of the recovered dose, with almost complete blood clearance of activity occurring by 10 minutes after injection. On the other hand, ^{35}S showed slow and incomplete blood clearance and no specific concentration of activity in any tissue examined. The authors believed that the differing biodistributions of the two tracers could be due to either loss of sulfur content from the particles before they reached the liver or loss of sulfur from particles following phagocytosis in the liver. It appears that the presence of $^{99\text{m}}\text{Tc}$ may modify the *in vivo* behavior of the sulfur colloid carrier. Alternatively, the *in vivo* environment may alter the physical and chemical properties of the radiopharmaceutical. These observations do not appear to have any major clinical significance.

The intracellular handling of sulfur colloid particles is not well understood. In general, engulfed material is contained within a phagosome or phagocytic vacuole which fuses with a lysosome to form a phagolysosome. The ultimate fate of the colloid particle depends on its susceptibility to enzymatic digestion. Lysosomes are known to contain a wide variety of hydrolytic enzymes including both acid and alkaline phosphatases, ribonuclease, deoxyribonuclease, nucleotidase, sulfatase, cathepsins, and glucosidases. Colloids may remain within the macrophages indefinitely, probably many times longer than the half-life of the radiolabels (23) or until the cell dies. It has been reported, however, that $^{99\text{m}}\text{Tc}$ -labeled sulfur colloid may be metabolized and digested by the lysosomal enzyme sulfatase (27).

The use of $^{99\text{m}}\text{Tc}$ -labeled macroaggregated albumin (MAA) is a well-established technique for the assessment of pulmonary perfusion and the detection of pulmonary emboli. After intravenous injection of MAA, particles ranging in diameter from 10 μm to 100 μm are trapped in

the precapillary arterioles of the lungs. Albumin macroaggregates, being loosely joined fragments of smaller particles, are malleable and may change shape. With use of cinemicroscopic techniques in the capillary beds of rabbit omentum, it was shown that MAA particles are forced through the arterioles by constant cellular bombardment and continuous forward and backward movement due to changing intra-arteriolar pressure (28). Similar conditions undoubtedly occur in the pulmonary vasculature and, along with mechanical movement of the lungs and proteolytic action, result in fragmentation of the macroaggregates. Phagocytosis and enzymatic digestion of these smaller particles in a manner similar to digestion of colloid particles results in the release of ionic $^{99\text{m}}\text{Tc}$ and/or $^{99\text{m}}\text{Tc}$ -labeled albumin fragments. With ^{131}I -MAA, free iodide and iodinated albumin breakdown products are released into the circulation (23). Labeled human serum albumin has been used for measuring blood volume and cardiac output. A significant fraction of albumin is lost into the gut where it is digested (29). After digestion, the label ($^{99\text{m}}\text{Tc}$ or ^{131}I) could be redistributed into the body.

$^{99\text{m}}\text{Tc}$ -labeled phosphate and phosphonate compounds are used in bone imaging and myocardial infarct imaging. These compounds include pyrophosphate (PYP), 1-hydroxyethylidene diphosphonate (HEDP), methylene diphosphonate (MDP), and hydroxymethylene diphosphonate (HDP). These compounds have replaced the polyphosphate compounds used earlier in nuclear medicine.

$^{99\text{m}}\text{Tc}$ -labeled phosphate and phosphonate compounds are metastable *in vivo* (30). Complex stability increases in succession from triphosphate, to PYP, to MDP, and to HEDP. Stability is associated with more protein binding. Complex breakdown occurs primarily in the extravascular space. Studies have shown that in rats, hydrolysis of $^{99\text{m}}\text{Tc}$ -labeled phosphate complexes leads to the formation of two compounds (31). The first, thought to be hydrated $^{99\text{m}}\text{Tc}$ -dioxide, has no affinity for bone, is not protein bound, and is excreted by glomerular filtration. The second compound, which is derived from the first, is a charged $^{99\text{m}}\text{Tc}$ (IV) compound which is protein bound.

This latter compound is thought to bind the organic bone matrix.

The stability characteristics of the phosphate and phosphonate compounds also are dependent on the order of linking of their atoms. Pyrophosphates have a P-O-P linkage which is readily hydrolyzed by pyrophosphatase to orthophosphate (32). Diphosphonates have a P-C-P linkage which is stable and resistant to hydrolysis (33). In fact, there are no known serum enzymes that hydrolyze diphosphonates (34).

Evaluation of the hepatobiliary system can be accomplished by use of various *N*-substituted derivatives of iminodiacetic acid (IDA). ^{99m}Tc-labeled IDA derivatives are cleared by an anionic clearance mechanism in a manner similar to that involved in bilirubin clearance (35). Increased bilirubin levels may decrease the clearance of these radiopharmaceuticals to varying degrees. The addition of high-molecular-weight substituents on the aromatic ring has been shown to increase hepatobiliary specificity (36). Studies in mice have shown that the *in vivo* kinetics of *N*-substituted iminodiacetic acid complexes may vary, depending on the structure, the polarity, or the molecular weight of the aromatic substituent (37). Liver affinity is decreased by increasing polarity, and substitution in the ortho position leads to complexes with increased urinary excretion rates. ^{99m}Tc-labeled *N*[*N'*-(2,6-dimethylphenyl)carbamoylmethyl]iminodiacetic acid (^{99m}Tc-HIDA) is excreted in the original radiochemical form and is not dissociated or metabolized (38).

^{99m}Tc-DTPA is a well-established radiopharmaceutical for brain and kidney imaging. ¹¹¹In-DTPA is used in cisternography studies. In studies in which ¹⁴C-DTPA was used in rats, it was demonstrated that after intravenous injection, 84% of the injected activity was excreted in the urine and 10% was excreted in the feces during the first 24 hours (39). In addition, the activity in the tissues was below 1% of the administered dose at 24 hours, and only 0.15% of the administered activity remained in the tissue at 39 days postinjection. In another study, 90–100% of an intravenously administered dose of ¹⁴C-DTPA was found in the

urine at 24 hour postinjection (40). The biological stability of ^{99m}Tc-DTPA was studied in humans (41). One hour after injection of ^{99m}Tc-DTPA, more than 98% of the ^{99m}Tc activity in the urine was in the form of the labeled chelate. In plasma samples, 80–90% of the ^{99m}Tc activity was in the labeled chelate form, 5–10% was associated with serum proteins, 1–4% was found as an unidentified compound, and less than 3% was found as uncomplexed [^{99m}Tc]pertechnetate (41).

Radioiodinated Pharmaceuticals

The use of radioiodinated (¹³¹I) pharmaceuticals in nuclear medicine has decreased in recent years due to its less-than-ideal energy characteristics and long physical half-life. ¹³¹I-labeled compounds are still used in renal imaging (*o*-[¹³¹I]iodohippurate), however, and most recently have been used in studies of the adrenal medulla and cortex (*m*-[¹³¹I]iodobenzylguanidine (mIBG) and ¹³¹I-NP-59, respectively).

The metabolism of *o*-[¹³¹I]iodohippurate involves four possible pathways (42). It may be (a) deiodinated, (b) deiodinated and simultaneously cleared to benzoic acid, glycine, and free iodide, (c) hydrolyzed to [¹³¹I]-iodobenzoic acid and ¹³¹I-glycine, or (d) excreted in the unmetabolized form. The latter pathway probably predominates due to the rapid clearance of the compound in the urine.

The imaging of the adrenal cortex with ¹³¹I-NP-59 (6β-[¹³¹I]iodomethyl-19-norcholest-5(10)-en-3β-ol) is based on the idea that NP-59, with a structure similar to cholesterol, will enter the biosynthetic pathway that utilizes cholesterol to produce steroid hormones. The conversion of the cholesterol to the various steroid hormones involves the hydroxylation of the side chain of cholesterol and the subsequent cleavage of the molecule between C₂₀ and C₂₂ by the enzyme desmolase. ¹³¹I-NP-59 has greater stability to deiodination than does 19-[¹³¹I]iodocholesterol (43).

The metabolism of the adrenal medulla imaging agent, ¹³¹I-mIBG, has been studied by use of ¹²⁵I-pIBG in dog liver homogenates (44). These studies have shown very slow enzymatic dehalogenation which is stimulated by

addition of glutathione (GSH). It was suggested that this dehalogenation is due to GSH-S-transferase in the liver. It was shown that *in vivo* dehalogenation also occurs.

SUMMARY

The metabolism of radiopharmaceuticals has been shown to be generally similar to the metabolism of nonradioactive drugs in many respects, including the enzyme systems utilized in biotransformation reactions. Detailed studies of radiopharmaceutical metabolism, however, are fewer and less extensive than studies of nonradioactive drug metabolism. The reasons for the overall lack of metabolic studies of radiopharmaceuticals have been variously attributed both to the lack of interest by clinicians and to the technological problems associated with analysis of tracer amounts of radiochemical compounds. It appears that in the race to develop newer and better radiopharmaceuticals over the past 20 years, clinical usefulness overshadowed more basic research areas such as metabolism. It is hoped that in the future a balance will be reached between applied and basic research, with the end result being a reexamination of many radiopharmaceuticals in terms of metabolism and kinetics.

REFERENCES

- Mayer SE, Melmon KL, Gilman AG: Introduction: the dynamics of drug absorption, distribution, and elimination. In Gilman AG, Goodman LS, Gilman A (eds): *The Pharmacological Basis of Therapeutics*, ed 6. New York, Macmillan, 1980, p 1.
- Hayes RL: The interaction of gallium with biological systems. *Int J Nucl Med Biol* 10:257–261, 1983.
- Anghileri LJ, Crone MC, Thouvenot P, et al: On the mechanisms of ⁶⁷Ga and ⁹⁹Tc uptake by tumors. *Nuklearmedizin* 22:152–154, 1983.
- Zivanovic MA, Taylor DM, McCready VR: The chemical form of gallium-67 in urine. *Int J Nucl Med Biol* 5:97–100, 1978.
- Gehring PJ, Hammond PB: The interrelationship between thallium and potassium in animals. *J Pharmacol Exp Ther* 55:187–201, 1967.
- Grunwald AM, Watson DD, Holzgreffe HH, et al: Myocardial ²⁰¹thallium kinetics in normal and ischemic myocardium. *Circulation* 64:610–618, 1981.
- Welch HF, Strauss HW, Pitt B: The extraction of ²⁰¹thallium by the myocardium. *Circulation* 56:188–191, 1977.
- Dossin E, Eberlin A, Briere J, et al: Metabolic fate of ¹¹¹In in the rat. *Int J Nucl Med Biol* 5:34–37, 1978.
- Thakur ML, Gottschalk A: Role of radiopharmaceuticals in nuclear hematology. In Sodd VJ, Hoogland DR, Allen DR, et al (eds): *Radiopharmaceuticals II*. New York, Society of Nuclear Medicine, 1979, pp 341–359.
- Sargent T III, Stauffer H: Whole body counting of retention of ⁶⁷Cu, ³²P, and ⁵¹Cr in man. *Int J Nucl Med Biol* 6:17–21, 1979.
- Oldendorf WH: Distribution of various losses of radio-labelled tracers in plasma, scalp and brain. *J Nucl Med* 13:681–685, 1972.
- Hays MT, Green FA: Binding of TcO₄ by human serum and tissues. *J Nucl Med* 12:365, 1971.
- Oldendorf WH, Sissons WB, Iisaka Y: Compartmental redistribution of Tc-99m pertechnetate in the presence of perchlorate ion and its relation to plasma protein binding. *J Nucl Med* 11:85–88, 1970.
- Spiers FW: *Radioisotopes in the Human Body: Physical and Biological Aspects*. New York, Academic Press, 1968, p 31.
- DeGroot LJ, Niepomnisyeze H: Biosynthesis of thyroid hormone: basic and clinical aspects. *Metabolism* 26:665–718, 1977.
- Schwartz HL, Oppenheimer JH: Physiologic and biochemical actions of thyroid hormone. *Pharmacol Ther* 3:349–376, 1978.
- Goth: *Medical Pharmacology*, ed 10. St Louis, CV Mosby, 1981, p 550.
- Chaudhuri TK, Evans TC, Chaudhuri TK: Autocardiographic studies of distribution in the liver of ¹⁹⁸Au and ^{99m}Tc sulfur colloids. *Radiology* 109:633–637, 1973.
- Hendershott LR, George EA, Klos DJ, Donati RM: Osmium staining of technetium sulfur colloid: a technique for electron microscopy. *Int J Nucl Med Biol* 5:56, 1978.
- Schell-Frederick E, Fruhling J, Vercammen-Grandjean A, Paridaens R: Mechanism of labelling of neutrophils and macrophages with ^{99m}Tc sulfur colloid. *Int J Nucl Med Biol* 8:118–121, 1981.
- Nelp WB: An evaluation of colloids for RES function studies. In Subramanian G, Rhodes BA, Cooper JF, Sodd VJ (eds): *Radiopharmaceuticals*. New York, Society of Nuclear Medicine, 1975, p 349.
- Saha GB: *Fundamentals of Nuclear Pharmacy*, ed 2. New York, Springer-Verlag, 1984, p 220.
- Nelp WB: Distribution and radiobiological behavior of colloids and macroaggregates. In Cloutier RJ, Edwards CL, Snyder WS (eds): *Medical Radionuclides: Radiation Dose and Effects*. Oak Ridge, TN, US Atomic Energy Commission, 1970, pp 239–252.
- Song C: Augmented splenic uptake of radiocolloid in patients with malignant melanoma. *Lancet* 1:460, 1974.
- Siemsen JK, Telfer N: Nuclear medicine. In Tubis M, Wolf W (eds): *Radiopharmacy*. New York, John Wiley & Sons, 1976, p 774.

26. Frier M, Griffiths P, Ramsey A: The biological fate of sulfur colloid. *Eur J Nucl Med* 6:371-374, 1981.
27. Warbick-Cerone A, Phythian JR: The role of endocytosis in the localization of radiotracers. In Anghileri LJ (ed): *General Processes of Radiotracer Localization*. Boca Raton, FL, CRC Press, 1982, vol 1, p 173.
28. Taplin GV, Johnson DE, Kennady JC, et al: Aggregated albumin labelled with various radioisotopes. In Andrews GA, Kniseley RM, Wagner HN (eds): *Radioactive Pharmaceuticals*. Oak Ridge, TN, US Atomic Energy Commission, 1966, p 525.
29. Winchell HS: Dosimetry considerations for radioisotopically labelled organic compounds. In Cloutier RJ, Edwards CL, Snyder WS (eds): *Medical Radionuclides: Radiation Dose and Effect*. Oak Ridge, TN, US Atomic Energy Commission, 1970, pp 225-238.
30. Schumichen C: Biokinetics of ^{99m}Tc -phosphate bone imaging agents. In Colombetti LG (ed): *Advances in Radiopharmacology*. Chicago, International Association of Radiopharmacology, 1981, p 217.
31. Schumichen C, Korfgen T, Hoffman G: Relationship between complex stability and biokinetics of ^{99m}Tc -phosphate compounds. *Nuklearmedizin* 19:7-10, 1980.
32. Stryer L: *Biochemistry*, ed 2. San Francisco, WH Freeman, 1981, p 531.
33. Krishnamurthy GT, Tubis M, Endow JS, et al: Clinical comparison of the kinetics of ^{99m}Tc -labelled polyphosphate and diphosphonate. *J Nucl Med* 15:848-855, 1974.
34. Krishnamurthy GT, Huebotter RJ, Tubis M, Bland WH: Pharmacokinetics of current skeletal-seeking radiopharmaceuticals. *AJR* 126:293-301, 1976.
35. Loberg MD, Porter DW, Ryan JW: Review and current status of hepatobiliary imaging agents. In Sodd VJ, Hoogland DR, Allen DR, et al (eds): *Radiopharmaceuticals H*. New York, Society of Nuclear Medicine, 1979, pp 519-543.
36. Burns HD, Worley P, Wagner HN, et al: Design of technetium radiopharmaceuticals. In Heindel ND, Burns HD, Honda T, Brady LW (eds): *The Chemistry of Radiopharmaceuticals*. New York, Masson Publishing, 1977, p 269.
37. Chiotellis E, Varvargan A: ^{99m}Tc -labelled *N*-substituted carbamoyl iminodiacetates: relationship between structure and biodistribution. *Int J Nucl Med Biol* 7:1-7, 1980.
38. Loberg MD, Cooper M, Harvey E, et al: Development of new radiopharmaceuticals based on *N*-substitution of iminodiacetic acid. *J Nucl Med* 17:633-638, 1976.
39. Crawley FEH, Haines JW: The dosimetry of ^{14}C carbon labelled compounds: the metabolism of diethylenetriaminepentaacetic acid (DTPA) in the rat. *Int J Nucl Med Biol* 6:9-15, 1979.
40. Stevens E, Rosoff B, Weiner M, Spencer H: Metabolism of the chelating agent diethylenetriaminepentaacetic acid (C-14 DTPA) in man. *Proc Soc Exp Biol Med* 111:235-238, 1962.
41. Hauser W, Atkins HL, Nelson G, Richards P: Technetium- ^{99m}Tc DTPA: a new radiopharmaceutical for brain and kidney scanning. *Radiology* 94:679-684, 1970.
42. Risch VR, Markoe AM, Honda T: The pharmacology and preclinical evaluation of radiopharmaceuticals. In Heindel ND, Burns HD, Honda T, Brady LW (eds): *The Chemistry of Radiopharmaceuticals*. New York, Masson Publishing, 1977, p 123.
43. Heindel ND: Principles of target tissue localization on radiopharmaceuticals. In Heindel ND, Burns HD, Honda T, Grady LW (eds): *The Chemistry of Radiopharmaceuticals*. Masson Publishing, 1977, p 11.
44. Tobes MC, Gildersleeve DL, Wieland DM, et al: Mechanisms of localization and metabolism of iodo-benzylguanidines, adrenal medullary imaging agents. *Int J Nucl Med Biol* 9:228-229, 1982.

5

Radiopharmaceutical Absorbed Dose Considerations*

Jack L. Coffey, Evelyn E. Watson, Karl F. Hubner, and Michael G. Stabin

GENERAL PRINCIPLES

The number of radionuclides with suitable physical and chemical properties acceptable as indicators in radiopharmaceuticals (radiopharmaceutical drug products, RDP) is limited. Compromises have to be made in the development of radiopharmaceuticals, since both the chemical and the physical characteristics of radionuclides have to be considered. Many times, some of the specificity of the RDP has to be given up when radiopharmaceuticals are selected for clinical use.

Important criteria for determining the acceptability and clinical usefulness of diagnostic and therapeutic applications of radiopharmaceuticals are the potential risk, the practicability, and the diagnostic or therapeutic result that can be expected. Practicability and potential diagnostic or therapeutic benefits are important factors in determining whether the risks are acceptable. The risks involved in the clinical use of radiopharmaceuticals are essentially the consequence of radiation exposure and, to some extent, the potential side effects of complications resulting from the chemical, biological, or physical nature of the radiopharmaceuticals.

Many risks that are of concern with other diagnostic procedures play only a secondary

role in nuclear medicine. More than 95% of the diagnostic nuclear medicine procedures are noninvasive. Handling of the patient is restricted to administering the radiopharmaceutical (intravenous injection, oral application, or inhalation) and, possibly, taking blood samples for radioassay.

Side effects from the chemical nature of the radiopharmaceutical are rare because the chemical amount of the radiotracer used is extremely small. The incidence of complications from radiopharmaceuticals has been found to be about 1 in 10,000 procedures. In comparison, side effects from contrast media in conventional radiography occur at a rate of approximately 1:6.5 to 1:250 procedures.

Thus, radiation exposure from the injected radioactive tracer to the patient and, specifically, the potential somatic and genetic effects of this exposure are the main concern. The risks from therapeutic applications of radionuclides are more easily accepted than are those resulting from diagnostic nuclear medical procedures.

The additional radiation load to the population from nuclear medical procedures is less than 10%. There is no epidemiologic evidence that this 10% increase would result in somatic damage within the population. So we are left with the general genetic risk which is primarily a collective risk and not of much concern to the individual.

Although the somatic risk is extremely low and the genetic risk is negligible with use of radionuclides in nuclear medicine, the physi-

* This work was performed under Interagency Agreement No. FDA 224-75-3016, DOE 40-286-71. Oak Ridge Associated Universities performs complementary work for the U.S. Department of Energy under contract DE-AC05-76OR00033.

cian who orders these tests should always weigh the results of the test against the radiation exposure risk to the patient. The dose from the radionuclide should be as low as possible, and the optimal test would always be one in which a radionuclide with a short half-life is used. On the other hand, too small an amount of activity results in insufficient information and a repetition of the test, which in the long run increases the radiation exposure. It is much easier to define a genetically significant dose as one for which nuclear medicine procedure is clearly indicated. If the decision of whether or not to order a nuclear medical test is based on this principle, the number of nonproductive tests or noninformative tests will be reduced and the use of higher doses may even be justified.

The radiation exposure in nuclear medicine is within the same range as the exposure from conventional radiographic examinations, and some diagnostic radiotracer studies result in a much lower exposure than do radiographic procedures. It may be said that the risk is lower with lower doses and that as the dose approaches zero, the risk also comes close to zero. Even the small fraction of additional radiation dose from a nuclear medicine test may represent a risk, however, and we should make every effort to reduce that risk as much as possible and practical. During the past 15 years, short-lived radionuclides have been used to reduce the radiation exposure to patients, to the point that now it is even possible to use nuclear medical procedures with children.

A key question concerned with reducing radiation exposure to the patient is whether another test can give the answer without the use of radiation and without the undue risks associated with other kinds of invasive diagnostic approaches. In many instances, nuclear medical or radiographic information, albeit of marginal value by itself, can give conclusive complementary or confirming information needed for the diagnostic, prognostic, or therapeutic management of a patient. If a nuclear medical procedure is indicated, we have to decide which radiopharmaceutical to use. In this regard we need to consider the pharmacokinetics of a particular radiopharmaceutical, bearing in mind that the patient's disease or altered physiology may af-

fect the pharmacokinetic pathways and, consequently, change the dose distribution and possibly the target organ dose.

The patient's age and weight are important considerations when a decision on the amount of activity to be administered is to be made. Age, especially in children, is a determining factor in this decision. Simply to adjust the activity on the basis of body weight is not satisfactory and could result in unnecessarily high radiation-absorbed doses in children, since the mass of certain organs relative to the body overall is quite different in a small child than in an adult. Furthermore, children have an overall increased radiosensitivity and increased functional and physiologic activities in certain tissues of the growing body (i.e., bone, thyroid). A safer approach to calculating a reasonable radiopharmaceutical administration for children is probably the body surface area, or Webster's rule (the pediatric dose = $x + 1$ over $x + 7$ times the adult dose, where x = age in years), or a simple and practical rule of thumb approach (children under 5 years receive 25% of the activity that would be given to an adult; those 5–10 years old, 50%; those 10–15 years old, 75%; and those older than 15 years, the same activity as adults).

Other factors that may affect the radiation dose from radiopharmaceuticals to patients are the patient's physical condition and ability to cooperate. If a nuclear medicine study cannot be completed because of those reasons, the study may have to be repeated, which leads to additional radiation exposure of the patient. Poor or inadequate preparation in general, and for specific tests in particular, may result in unsatisfactory studies and unnecessary radiation doses. In addition, poor quality assurance procedures and sloppy techniques in the radiopharmaceutical laboratory (dose prescribing, dose calculation, and dose calibration) and during administration of the activity (mislabeling syringes, wrong patient, etc.) result in avoidable misadministrations. Most of the misadministrations and unnecessary exposures are due to human factors in nuclear medicine quality control.

Benefit-risk ratios can be calculated for nuclear medical procedures if certain assump-

tions, such as acceptance of a linear dose-effect relationship for low doses and the use of a statistical approach for measuring the benefit from nuclear medicine and determining the probability of the development of radiation-induced neoplastic diseases, are made. The benefits gained from nuclear medical tests outweigh the risks, however, provided the indication for the test is justified and modern principles of radiopharmaceutical applications and high-standard quality control procedures are used.

RESPONSIBILITIES AND VIEWS OF REGULATORY AGENCIES

Licensed physicians can use any method or agent they believe would help in managing their patients, including devices or agents that have risks associated with their use. The physician has the responsibility of weighing the benefits to be derived from a device or agent against any risks in order to determine whether its use is warranted. Although regulatory agencies do not prevent physicians from practicing medicine according to their judgment, the agencies do have responsibility for issuing guidelines for the use of drugs, biologic products, and devices and to ensure that these guidelines are safe and effective.

For many years after World War II, radiopharmaceuticals were exempted from the regulations that applied to nonradioactive drugs and were distributed under the regulatory supervision of the U.S. Atomic Energy Commission. This exemption began with the introduction of radioactive drugs containing by-product radionuclides and became official in 1963 (1) when the Investigational New Drug Regulations were put in force. In 1971, the Food and Drug Administration (FDA) which is the federal regulatory agency that has responsibility for the safety of foods, cosmetics, drugs, and medical devices became more involved in the use of radiopharmaceuticals and called for the submission of new drug applications (NDAs) for the "well-established" radioactive drugs (2). This resulted in the approval of a large number of NDAs for radiopharmaceuticals that had been used routinely by clinicians for several years.

Since 1975, when the exemption for radiopharmaceuticals from the investigational

new drug provisions was ended, radiopharmaceuticals have been regulated in the same way as all other drugs. Review groups in the Center for Drugs and Biologics (formerly the Bureau of Drugs) of the FDA evaluate applications for marketing (NDAs) and investigational new drug exemptions (INDs) of radiopharmaceuticals. An NDA is approved only if the applicant shows that the drug is safe, effective, and properly manufactured. Substantial evidence of effectiveness is required by law and must consist of adequate and well-controlled investigations, including clinical investigations, conducted by persons considered to be qualified to evaluate the effectiveness of the drug when used according to the proposed labeling (package insert).

In addition to the FDA which regulates the manufacture and use of radiopharmaceuticals, the U.S. Nuclear Regulatory Commission (NRC) has authority over by-product, special nuclear, and source material but not over naturally occurring and accelerator-produced radioactive materials. By-product material is material made radioactive by exposure to radiation from the use or production of special nuclear materials and uranium mill tailings. Special nuclear material is ^{233}U or plutonium or uranium enriched with ^{233}U or ^{235}U ; source material is uranium or thorium in any form. Because uranium and transuranics are not used in nuclear medicine, only radiopharmaceuticals that contain by-product material are subject to NRC regulations.

The various states also have regulatory powers over the use of radioactive materials. The kind of control that is exercised depends on the individual state; the state programs can be divided into three basic types, however. *Agreement states* have reached an agreement with the NRC to license by-product, source, and special nuclear material. *Licensing states* license naturally occurring and accelerator-produced radioactive materials. *Registration states* register naturally occurring and accelerator-produced radioactive materials. The different policies of these agencies that have regulatory powers tend to make the use of radiopharmaceuticals particularly difficult. Anyone wishing to use radiopharmaceuticals must obtain information from the state radiological health department about

the applicable regulations as well as become familiar with NRC regulations (see Chapter 21) and FDA requirements (see Chapter 23).

Investigational New Drugs

Before testing any new drug, whether it is radioactive or not, the investigator must comply with the requirements that certain safeguards are used in the studies. One method of doing this is to file a "Notice of Claimed Investigational Exemption for a New Drug," commonly called an IND. Details of the IND process are given in Chapter 23; those areas of the IND which are pertinent to radiation dose calculations, however, are also briefly covered here.

The primary requirements of an IND are:

1. Complete information about the composition of the drug
2. Results of all preclinical investigations of the drug
3. The protocol for the investigation
4. Qualifications of the investigators
5. Information on any adverse effects
6. Submission of annual progress reports

Of these requirements, the second (results of all preclinical investigations) is the one that is most relevant to this chapter. Before human studies can be initiated, studies in animals must be carried out to determine the biologic distribution and retention as well as the toxicity of the material. The phrase "biologic distribution and retention" takes into account the excretory pattern of the radionuclide, and these factors are essential to making a meaningful estimate of the radiation dose to the patient. These initial estimates usually are derived from studies in rats and mice, with some limited data coming from larger animals to evaluate interspecies differences. The actual design of the preclinical studies is left to the discretion of the investigators; the studies should be planned, however, so that virtually all of the administered activity is accounted for at several different times after administration. Distribution and retention studies in animals with induced disease conditions representative of those for which the radiopharmaceutical is intended may also be required to show how the radiation dose differs in abnormal conditions. These studies also serve to demonstrate the effectiveness of the proposed agent.

The FDA requests that the radiation dose calculations be made in accordance with the schema (3) of the Medical Internal Radiation Dose (MIRD) Committee of the Society of Nuclear Medicine or with a comparable technique. The basic equation for the MIRD technique is

$$\bar{D}(r_k) = \sum_h \bar{A}_h S(r_k \leftarrow r_h) \quad \text{Equation 5.1}$$

where \bar{D} is the mean dose, \bar{A} is the cumulated activity, and S is the absorbed dose per unit of cumulated activity. The symbols r_k and r_h represent a target region and source region, respectively. The equation describing the absorbed dose per unit cumulated activity, S , is

$$S(r_k \leftarrow r_h) = \sum_i \Delta_i \Phi_i(r_k \leftarrow r_h) \quad \text{Equation 5.2}$$

where Δ_i is the mean energy of the i th type of radiation emitted per unit cumulated activity, and Φ_i is the specific absorbed fraction of energy. The Δ value is the product of the factors k , n , and E for each type of radiation, where k is a constant based on the units to be used (2.13 in MIRD schema for traditional units of radiation dose in rad), n is the fractional abundance of the radiation emissions, and E is the energy in MeV. The specific absorbed fraction, Φ , is the absorbed fraction, ϕ , divided by the mass of the target organ. The absorbed fraction, ϕ , is the fraction of the total energy emitted in a source organ which is absorbed by a target organ. A mathematical model of the body and its organs is needed to calculate absorbed fractions, specific absorbed fractions, and S values.

Values of S for a mathematical model of Reference Man have been published by the MIRD Committee (4) and others (5-9). Although radiopharmaceuticals are administered to women and children, the radiation dose estimates for Reference Man have been accepted by the FDA as representative of the dose to any patient. If S values for children become readily available, radiation dose estimates for children of various ages may be required for radiopharmaceuticals that could have potential value in children.

The cumulated activities, \bar{A} , usually are determined from preclinical studies and may require extrapolation from values obtained in animals to values expected in humans. Consequently, the animal studies should be carefully planned and executed so that the necessary in-

formation will be obtained. The FDA generally requires dose estimates for the organ or organs receiving the highest radiation dose, for the gonads, for the bone marrow, and for the total body. Techniques for calculating cumulated activities have been described in many different publications, two of which are MIRD Pamphlet No. 1, Revised (3), and MIRD Pamphlet No. 12 (10). These are helpful in understanding the general principles of calculating the number of nuclear transformations that will occur in a source organ over a particular time period but do not give guidance on techniques for extrapolating animal data to humans. Several papers presented at the Third International Symposium on Radiopharmaceutical Dosimetry and published in the *Proceedings* are helpful in analyzing data from animal studies and in using them for estimating radiation dose in humans (11-17).

After the sponsor of a new drug submits the IND to the FDA, the responsible staff in the Center for Drugs and Biologics of the FDA must review the document. The primary purpose of this review is to evaluate the potential problems in the proposed clinical trial; this review is performed by a chemist, a pharmacologist, and a physician. If the FDA does not notify the sponsor to the contrary in 30 days after receipt of the IND, the sponsor may initiate the clinical trials.

The clinical investigation is conducted in three phases. Phase I consists of a study in a limited number of human subjects to obtain pharmacokinetic data on the radiopharmaceutical. These studies should demonstrate the normal biodistribution, clearance half-time, routes of excretion, the organs that show the highest concentration of the radionuclide, and the optimum imaging or sampling times. Children and pregnant or lactating women are excluded from phase I studies. Patients with selected diseases may be studied to evaluate distribution and excretion alterations that may be caused by the disease process. These changes may significantly affect the radiation dose received by the patient.

An alternative mechanism to the submission of an IND for performing a limited number of clinical trials is to obtain approval by a local institutional committee (18). Such a committee,

called a Radioactive Drug Research Committee (RDRC), is approved by the FDA to act on its behalf. An RDRC can approve a research study with the radiopharmaceutical if it is shown that the radiation exposure to the patient is less than the prescribed maximums (similar to the maximum permissible exposures for occupational workers); that the active ingredients in the pharmaceutical are known not to cause any clinically detectable pharmacological effect in humans; that the rights of human subjects will be protected through review of the research by an institutional review board; that the radiopharmaceutical meets chemical, pharmaceutical, radiochemical, and radionuclidic standards of identity, strength, quality, and purity; that the research protocol is scientifically sound; and that the investigators are qualified to conduct the proposed study and licensed to handle radioactive materials. Activities of an RDRC must be reported periodically to the FDA for review.

Phase II studies are conducted by two or more independent investigators and are intended to evaluate the safety and effectiveness of the radiopharmaceutical under conditions of clinical use of the drug. These studies should be designed to collect sufficient evidence to document the nature of any adverse effects or the absence of such effects and to demonstrate the reliability of the diagnostic information obtained with use of the agent.

Phase III, the last portion of the investigation, is needed to provide statistically reliable information on the safety and efficacy of the drug. For this reason, much larger numbers of patients are used. Once the clinical evaluation of a new drug is completed and the drug is found to have potential use in medicine, the sponsor will seek to have the drug approved for marketing. In order to accomplish this, a new drug application (NDA) is filed with the FDA.

New Drug Applications

The new drug application is an extremely voluminous document and details all of the information that has been compiled on the drug, including all the manufacturing and control information as well as the preclinical and clinical data. Individual case reports are required. The information that will be included in the package insert must be submitted. Adverse effects must

be well documented. The FDA must analyze the information to ascertain the safety and effectiveness of the drug and establish that the labeling (package insert) information is documented by the studies that have been performed.

The approval of new drug applications in the United States has been quite slow. In fact, the average time for approving a radiopharmaceutical NDA has been about 2 years (19). Usually, the blame for the long lag time from initiation of clinical studies to approval of the drug for marketing is placed on the FDA; the fault must be shared, however, with the manufacturers and the nuclear medicine physicians. According to Frankel and Kawin (19), many of the phase III studies are not adequate and well controlled. Even though the studies can be used for supportive evidence, they are not sufficient for approval of an NDA. Frankel suggests two ways to avoid this: (a) to have an adequate protocol followed carefully after it has been developed and agreed on by the FDA and the investigators and (b) to have a meeting between manufacturers and reviewers so that everyone understands the protocol and the agreements that have been reached.

After a NDA is approved, the drug can be distributed to licensed nuclear medicine facilities for use. The package insert accompanying the drug contains the caution that it should not be used in pregnant or lactating women or children unless the benefit to be gained outweighs the risk of the study. Absorbed dose calculations for pregnant or lactating women or children are not included in the package insert. These calculations present special problems because of differences in organ size and location as well as total body size.

PEDIATRIC RADIATION DOSE ESTIMATION

The problem of estimating radiation dose to children from internally deposited radionuclides, as with any radiation dose estimate, breaks down into two simpler problems: (a) quantifying the biologic parameters and (b) quantifying the physical parameters. The former refers to the sum of the information regarding the distribution and retention of the radioactive compound. The latter describes the

characteristic decay modes of the radioisotope, the frequency of each type of emission, and the geometry in which the energy is released and deposited.

The physical parameters are much more easily understood and, consequently, are better studied, so they will be considered first. In the MIRDO technique for calculating internal radiation dose (3), a single factor describes the energy deposited in a region of the body. This factor is called the *S* value, and values have been calculated for a geometric model designed to approximate the size, shape, and composition of the adult human (4). The basic units of the *S* value are absorbed dose per unit of cumulated activity. The *S* value itself may be broken down into two parts, one being the decay data for the radionuclide (decay energy and branching) and the other being the fraction of energy emitted in a source region which is absorbed in a target region per unit mass of the target region (specific absorbed fraction).

For convenience in calculating *S* values, the radiations emitted by a radionuclide are often grouped according to the penetrability of the radiation. If essentially all of the energy would be deposited in the source region, the radiation is called nonpenetrating radiation. If the radiation could be deposited in other regions, it is called penetrating radiation. Typically, the specific absorbed fraction for the nonpenetrating radiation is 1 divided by the mass of the region, when the source and target regions are the same, and is 0, when the source and target regions are different. For penetrating radiation, regardless of whether the source and target regions are the same or are separate, the specific absorbed fraction is the fraction of energy originating in the source region that is absorbed in the target, divided by the mass of the target region. These fractions usually are calculated by generating Monte Carlo photon histories for several photon energies for each of the (20 or more) source organs and by correlating the point of absorption with the geometries of the target organs.

Because the decay data for the different radionuclides are fixed, only the specific absorbed fractions will change for the various age groups. Once specific absorbed fractions are

calculated, however, *S* values may be generated for any given radionuclide. An early attempt to generate these specific absorbed fractions for children involved shrinking of the human phantom, until the weight matched that of the human at the various ages, by factors related to the ratio of the cube root of the masses (20). This resulted in significant distortion of the true size, shape, and orientation of many organs. Similarly, *S* values for 62 radionuclides, based on scaling of the adult *S* values by factors related to the distance between the centers of mass of target-source organ pairs, were published for five pediatric age groups (21, 22). Other investigators (23–25) remodeled the adult phantom to represent the newborn, the 1-year-old, the 5-year-old, and the 15-year-old and generated specific absorbed fractions for several energies. Cristy (26) has designed phantoms representing the newborn, the 1-year-old, the 5-year-old, the 10-year-old, and the 15-year-old which are based on the changes in organ system size and placement with age, not simply on size scaling of the adult phantom. Cristy and Eckerman (27) have generated specific absorbed fractions for the various organs in the phantom, using 25 source regions and 25 target regions. *S* values can be easily calculated for specific radionuclides.

Biologic data describing radionuclidic behavior in children are lacking. Most biodistribution data used to generate pediatric absorbed doses are based on information from either healthy human adults or animals. Consequently, the accuracy of the generated estimates is open to question. Some information is known about the variation in biokinetics with age. For instance, newborns have lower renal blood flow, glomerular filtration rate, and transport of hepatobiliary agents, more rapid washout of radioactive gases, and greater uptake of bone-seeking radiopharmaceuticals than do adults (28), a poorly formed blood-brain barrier, and an incomplete enzyme complement (29). The number of alveoli increases rapidly during the first year of life and then more gradually, reaching the number found in adults at about 8 years of age (30). The number of pulmonary arteries also increases rapidly between the ages of 4 months and 3 years (31). These physiologic parameters become closer to adult values with

maturation, but clearly the quantitation of the changes would help to improve the accuracy of dose estimates generated for children of various intermediate ages. For short-lived radionuclides, however, variations in the biologic half-time are often unimportant in the final outcome of effective half-time and absorbed dose.

Some radionuclide studies performed in children include renal studies, lung scans, thyroid scintigraphy, splenic scintigraphy, bone scans, cardiac studies, and gastric emptying studies. In renal studies, $^{99m}\text{Tc}(\text{Sn})$ -diethylenetriaminepentaacetic acid (DTPA) may be used to evaluate renal perfusion, functioning renal mass, and glomerular filtration rate, as well as to visualize various anatomic structures. ^{99m}Tc -gluceptate is used to visualize the renal cortex and the pelvicalyceal collecting systems. ^{99m}Tc -dimercaptosuccinic acid (DMSA) is used to outline renal morphology and to differentiate function. In addition, follow-up cystography studies often are performed with ^{99m}Tc -pertechnetate or sulfur colloid. ^{81m}Kr and ^{133}Xe are used for lung ventilation studies in children, with the latter being either inhaled or given in a saline injection. Lung perfusion studies may be performed with ^{99m}Tc -labeled macroaggregated albumin (MAA) or ^{99m}Tc -labeled albumin microspheres. Thyroid studies will commonly employ some radioactive iodine as NaI. Spleen scans have been carried out with use of ^{99m}Tc -labeled heat-treated red blood cells (RBC). Liver-spleen scans usually are performed with ^{99m}Tc -labeled sulfur colloid. The ^{99m}Tc -labeled phosphate compounds are used widely for bone studies, with methylene diphosphonate (MDP) currently being the most popular. In cardiac studies, ^{99m}Tc -labeled RBC, pertechnetate, or human serum albumin (HSA) may be employed. In gastric emptying studies, usually some ^{99m}Tc compound such as sulfur colloid tagged to some food item is employed. Carrier-free ^{67}Ga is widely used to image soft-tissue and bone malignancies.

Therefore, a large amount of distribution data is needed to quantify the radiation dose to children from these procedures. Li et al. (32) have listed dose estimates for 1-year-olds and 15-year-olds to the lungs, gonads, and total body for ^{81m}Kr and ^{133}Xe gas used for ventilation

studies. The *S* values used, however, were directly from absorbed fractions for the adult. The distribution data also came from adult studies. Kereiakes et al. (33) generated radiation dose estimates to the thyroid for ^{123}I , ^{125}I , ^{131}I , and ^{132}I as iodide for newborns, 1-year-olds, 5-year-olds, 10-year-olds, and 15-year-olds. Their biologic data came from several sources; they concluded that the biologic half-time (68 days) did not vary significantly with age and that a mean uptake of 27% of the administered activity could be used for all except the newborn, for which they used 70%. They noted that thyroid uptake in the first 2 weeks of life can be very high. Wellman et al. (34) found that values in this age span could approach 100%, although the average for all other age groups was around 30%. The biologic half-time and generated dose estimates for the adult agreed well with the values found in MIRD Dose Estimate Report No. 5 (35). Henrichs et al. (22) quoted age-specific effective half-times for ^{131}I in the thyroid, from which age-specific biologic half-times for iodide may be inferred (Table 5.1). The age-specific dose estimates for the thyroid from ^{131}I , which are calculated by using the scaled *S* values of Henrichs et al. (22), agree fairly well with the values of Kereiakes et al. (Table 5.2). Ball and Wolf (36) generated dose estimates for a variety of agents for newborns, 1-year-olds, 5-year-olds, 10-year-olds, and 15-year-olds, considering only organ self-irradiation and using geometric factors of Hine and Brownell (37). James et al. (38) also published dose estimates for several radionuclides for

Table 5.1.

Age-specific Values of the Biologic Half-time (t_b) of Iodides in the Thyroid*

Age (yr)	t_b (days)
0	14.0
0.5	23.6
1	25.3
3	29.1
5	29.1
10	44.1
15	48.7

* Extrapolated from the age-specific effective half-times for ^{131}I as determined by Henrichs et al. (22).

Table 5.2.

Comparison of the Age-specific Dose Estimates for the Thyroid from ^{131}I as Determined by Kereiakes et al. (33) and Henrichs et al. (22)

Age (yr)	Estimated Radiation Dose (rad/ μCi)	
	Kereiakes et al.	Henrichs et al.
0	16.0	13.0
1	10.9	13.0
5	5.1	7.5
10	3.0	4.1
15	2.1	2.7

these age groups, considering only organ self-irradiation.

Although advances have been made in quantifying the physical parameters involved in calculating radiation dose to children of various ages, there is little information available currently about the biologic parameters. Age-specific radiation dose estimates are of great importance to the physician who wants the administration of activity to be as low as possible to achieve a suitable scan image. Both enthusiasm in the medical professional community and support from the regulatory agencies are needed to formulate and execute studies that will establish the metabolic properties of these radionuclides in children.

Radiation Risks

In virtually all animal studies, life-shortening has been shown to be more pronounced when irradiation occurs earlier in life. This difference may, however, be accounted for in part in that the latent period for deaths resulting from cancer induction exceeded life expectancies at irradiation for some of the older age groups. In human studies, a general pattern of increased susceptibility to cancer induction with increasing age is observed in those over age 20, and trends in those below age 20 vary with the type of cancer (39). Typically, latent periods are somewhat longer in younger age groups.

Analysis of the atomic bomb survivors has shown that persons irradiated before age 15 had the highest incidence of both chronic and acute leukemia and a higher number of excess deaths per million persons per year per rad to the bone marrow than did all other age groups except

those exposed after age 50. The younger age groups also seemed to have a shorter latent period.

There are some indications that persons under age 20 have a higher risk of thyroid cancer per rad than do those in older age groups. The numbers from the atomic bomb survivors indicate this trend but are based on a small sample size. Medical findings among the Marshall Islanders show a rate of incidence of benign thyroid lesions in children under age 10 to be four times that in the older exposed population.

Other observations of the atomic bomb survivors show that the risk for breast cancer is highest among females in the 10–19-year-old group, declines with age until age 50, and then increases again. For those under age 10, absolutely no incidence of breast cancer was observed. This pattern is understandable, since major hormonal changes are occurring in women in the second decade of life.

RADIATION HAZARDS INVOLVING RADIOPHARMACEUTICAL ADMINISTRATIONS TO LACTATING MOTHERS

Breast milk is composed of water, fat, lactose, casein, other proteins, and ash. The consistency is that of fat droplets surrounded by a membrane, in a suspension of transudate consisting of milk, proteins, sugar, salts, and water. Immediately after birth, the loss of estrogen and progesterone secretion by the placenta removes the inhibiting effect of these hormones on prolactin production by the pituitary gland. The prolactin stimulates synthesis of large quantities of fat, lactose, and casein, and breast milk production becomes copious within 2 to 3 days. Milk production may continue for several years if the mother continues to breast feed, but typically lasts only 7–9 months.

Calcium and phosphate are needed in large quantities for milk production; 2–3 gm of calcium phosphate may be lost from the mother's body each day. Fifty gm of fat and 100 gm of lactose (the latter derived from the mother's glucose) also are used each day. Thus, any radioactive element that may substitute for elements required in the production of breast milk

may eventually reach the nursing baby's system and present a radiological hazard.

Radionuclides Transmitted to Breast Milk

Evidence has been reported of the appearance of ^{67}Ga , ^{99m}Tc , ^{131}I , ^{125}I , and ^{113m}In in the breast milk after administration of compounds labeled with one of these radionuclides. Quantitation of the amount of activity in the milk at various times postinjection (PI) is rather easy (usually involving counting of a standard quantity of milk in a well gamma counter and comparing the result to that of a known radioactive standard in the same volume) and is widely reported in the literature. Quantitation of the radiation hazard to the infant, however, has been hampered by the lack of age-specific distribution and retention data and by the lack of a widely accepted phantom for the infant. The latter need has perhaps been met by Cristy and Eckerman (26, 7), with their pediatric phantoms and associated specific absorbed fractions for photons. The lack of distribution and retention data probably will not be resolved in the near future; almost all radiation dose estimates are based on the assumption that the infant's metabolism either parallels or equals that of an adult.

^{67}Ga has been observed in human breast milk after administration of [^{67}Ga]gallium citrate (48, 49). Tobin and Schneider (48) studied the concentrations in enough detail to determine an effective retention half-time. In their study, the concentrations decreased monotonically with an effective half-time of 57 hours. In the study by Larson and Schall (49), samples taken at 96 and 120 hours showed the same concentration. Both studies indicate that the effective half-time is close to the physical half-life of ^{67}Ga . The maximum reported concentrations, expressed as the fraction of injected activity per unit volume of milk, were $5.0 \times 10^{-5}/\text{ml}$ and $2.3 \times 10^{-5}/\text{ml}$ (Table 5.3).

The most data reported in the literature on radionuclides in breast milk have been collected on ^{99m}Tc -labeled compounds (50–57). Administrations of ^{99m}Tc -labeled pertechnetate or macroaggregated albumin (MAA) were followed by measurements of ^{99m}Tc activity in the breast milk at various times PI. Table 5.3 lists the results reported by the various authors. An inter-

Table 5.3.

Maximum Concentrations and Effective Half-times (t_{eff}) Reported in the Literature for Various Radionuclides Appearing in Breast Milk after Radiopharmaceutical Administrations

Radionuclide/Compound	Maximum Reported Concentration*	Time (hr) [†]	Maximum Concentration at 5 hr*	t_{eff} (hr)	Reference
⁶⁷ Ga	5.0×10^{-5}	72		57	48
⁶⁷ Ga	2.3×10^{-5}	96 - 120‡		78‡	49
^{99m} Tc-MAA	4.0×10^{-5}	~5	4.0×10^{-5}	4.6	54
^{99m} Tc-MAA	$\sim 1.0 \times 10^{-4}$	~6.5	1.0×10^{-4}	3.6	54
^{99m} Tc-MAA	1.5×10^{-5}	4	1.5×10^{-5}	2.8	51
^{99m} Tc-MAA	3.5×10^{-6}	6	3.5×10^{-6}	5.6§	52
^{99m} TcO ₄ ⁻	8.3×10^{-6}	10	1.8×10^{-5}	5.5	53
^{99m} TcO ₄ ⁻	5.1×10^{-5}	2	5.1×10^{-5}	3.6	53
^{99m} TcO ₄ ⁻	1.1×10^{-5}	22	1.4×10^{-4}	4.6	56
^{99m} TcO ₄ ⁻	1.4×10^{-2}	2	1.4×10^{-2}	3.4	55
^{99m} TcO ₄ ⁻	5.4×10^{-3}	2.4	5.4×10^{-3}	3.9	55
^{99m} Tc-Sn-polyphos	2.0×10^{-5}	5	2.0×10^{-5}		57
¹²⁵ I-fibrinogen	8.2×10^{-6}	108		67	54
¹²⁵ I-fibrinogen	3.5×10^{-5}	40		80	58
¹³¹ I-MAA	1.4×10^{-4}	23		20	53
¹³¹ I-MAA	2.0×10^{-5}	14		19	53
¹³¹ I	2.0×10^{-5}	24			59
¹³¹ I	1.3×10^{-5}	24			59
¹³¹ I	3.9×10^{-5}	6		6.5	59
^{113m} In chelate	2.5×10^{-7}	1.7		23**	60

* Units are fraction of injected activity per milliliter of milk.

† Time at which listed maximum was reported.

‡ Same concentration reported at 96 and at 120 hours. Physical half-life for ⁶⁷Ga reported for t_{eff} .

§ Curve had a shoulder similar to that reported in Reference 54.

|| Patient admitted for study of enlarged thyroid.

¶ Same patient, treated while nursing 4-month-old infant, at two times, 2 months apart.

** Suggested from the data, but impossible; most likely T_{bio} .

esting contrast emerges between the extremely broad range of breast milk concentrations and the rather narrow range of effective half-times of the activity in the milk. Berke et al. (51) studied chromatograms of the sampled milk after administration of ^{99m}Tc-MAA and confirmed that the ^{99m}Tc activity was, indeed, free pertechnetate. Therefore, the fraction of injected activity appearing in the milk should be less for the MAA group than for the free pertechnetate group, since the tagging efficiency for the MAA should be at least 90%.

For all of the technetium compounds, the variation in the reported effective half-times was low; the mean and standard deviation of all values combined were 4.2 hours and 0.96 hours, respectively. Sometimes, the curves

showed a clear pattern of ingrowth, often with a shoulder. Therefore, it is not possible to decay-correct all of the values to time 0, and a time of 5 hours was chosen (Table 5.3), since it was past the shoulder of the ingrowth curve in all cases. The decay correction was carried out so that values reported at long times PI could be included with the other values to obtain a more reasonable value for the average maximum fraction of injected activity appearing in the breast milk. Although the average concentration in patients seemed to be higher for ^{99m}TcO₄⁻ than for the ^{99m}Tc-MAA, the patient-to-patient variability was so large that any difference between the means was obscured at the 0.1 significance level.

Two patients receiving ¹²⁵I-labeled fibrinogen

for study of suspected venous thrombi (54, 58) showed a mean fraction of injected ¹²⁵I in the breast milk of 2.2×10^{-5} /ml, with a standard deviation of 1.9×10^{-5} /ml. The half-time for disappearance for the ¹²⁵I was 73.5 ± 9.2 hours. Two patients receiving ¹³¹I-MAA for diagnosis of suspected pulmonary emboli (53) had measured fractions of injected activity of 8×10^{-5} /ml $\pm 8.5 \times 10^{-5}$ /ml, with an effective half-time of 19.5 ± 0.7 hours. In both patients, however, the time of maximum activity was around 30 hours. With both of these compounds, at least in the limited number of patients, the pattern seen with the ^{99m}Tc-labeled compounds, of better agreement between the reported effective half-times than between the uptake fractions, was reproduced.

One further study from the literature describes a patient who received 0.65 GBq (17.5 mCi) of an ^{113m}In chelate complex for a brain scan (60). Activity concentrations measured at 1.67 and 21.5 hours PI were 2.5×10^{-7} /ml and 1.4×10^{-7} /ml, respectively. These data alone would suggest an impossible effective half-time of 23 hours (no mention was made of the data being decay-corrected), which would indicate that more data must be considered before a quantitative assessment of effective half-time can be made.

In conclusion, several radionuclides will appear, to some degree, in the breast milk of lactating mothers. Although the fractional uptake usually is very low, on the order of 10^{-6} ml- 10^{-4} /ml, the radiation dose to the infant may be considerable for two reasons. First, the infant may consume as much as 800-1500 ml of milk per day, which, in a worst case, might result in the infant consuming a significant percent of the injected activity. Second, on a per unit activity basis, the radiation dose to an infant will be considerably larger than that to an adult because the internal organs are in closer proximity, which results in more cross-irradiation, and because the organs are smaller, which results in larger doses per unit activity for self-irradiation. Both iodine and technetium will concentrate to some degree in the thyroid. As noted by Wayne et al. (61), "The maximum thyroid irradiation would occur at the age of 6 months[,] since the size of the gland at that age

is as small as at birth, whereas the milk intake has increased. . . . However, the maximum radiation dose may not coincide with the maximum hazard[,] since gland radiosensitivity may be greater at birth." What is clear from the observed data is that the amount of activity entering the breast milk will be highly patient-specific, although the parameters involved in the variability are not clearly defined. It is difficult to advise a woman about how long to interrupt breastfeeding after a radiopharmaceutical study, because fractional uptakes published in the literature may tell little or nothing about the behavior of the material in the patient under study. It appears that the averages generated here for *effective half-times*, which were calculated from the various studies, will be reliable for most patients, unless there is a known, special biophysical condition. Because of the uncertainty in the estimates of fractional uptake, however, recommendations should be on the conservative side; i.e., they should be based on longer rather than shorter interruption times.

Radiation Dose Estimation

The variability of the data regarding the fraction of injected activity appearing in the breast milk suggests that a general value for absorbed dose to the mother or infant per unit injected activity would be unreliable. In situations involving lactating mothers for which radionuclide administrations are unavoidable, reliable dose estimates will result only from actual measurements of the activity in the patient's breast milk. Although the variability of the effective half-times is not as great, the sampling should be designed to measure this parameter, since some patient-to-patient variation is seen and the activity does not always follow a previously observed pattern. An example of this deviation is the appearance of activity in breast milk after injection of ¹²⁵I-labeled fibrinogen, as described in the previous section, "Radionuclides Transmitted to Breast Milk." The 15-year-old phantom of Cristy (26) is a reasonable representation of Reference Woman, and the specific absorbed fractions generated for this phantom (27) include values for photon self-absorption in the breasts. Therefore, once S values are generated for the breasts, absorbed

dose estimates for the breasts may be approximated. Specific absorbed fractions for the breasts as a source organ may also be used to calculate the radiation absorbed dose to other organs of the body from activity in the breast milk by the standard MIRD technique (3).

For calculation of the radiation dose to the infant in situations in which breastfeeding was inadvertently continued soon after a radiopharmaceutical administration, one must determine the retention of the activity in the breast milk over the interval during which feeding occurred. If the situation is discovered after feeding has occurred, samples of the milk should be taken immediately and regularly until a pattern is established. The times at which the infant fed and the approximate amount of each feeding should be established, and the observed pattern should be back-projected to estimate the amount of activity available for uptake at each feeding. The general formula for calculating the total activity ingested by the infant on the basis of a monoexponential decay process would be:

$$A_t = \sum_{i=1}^n A_0 \exp(-\lambda t_i) V_i \quad \text{Equation 5.3}$$

where A_t is the total activity ingested (Bq or μCi), n is the total number of feedings, A_0 is the maximum activity concentration in the breast milk, which is projected from the observed data (Bq/ml or $\mu\text{Ci/ml}$), λ is the observed effective decay constant for the radionuclide in the breast milk (0.693 divided by the observed effective half-time) (hour^{-1}), t_i is the time between the occurrence of the maximum activity concentration and feeding time i (hours), and V_i is the volume of milk ingested at feeding i (milliliters).

Hays (62) observed that the fraction of ingested $^{99m}\text{TcO}_4^-$ in the infant's bloodstream varied widely from patient to patient and even from trial to trial in the same patient. Because values did approach 100% in many instances, complete absorption in the infant should probably be assumed for dosimetry.

Dose estimates for the newborn from $^{99m}\text{TcO}_4^-$, with Cristy and Eckerman's specific absorbed fractions for photons and Cristy's organ weights used (to obtain specific absorbed fractions for nonpenetrating radiations), and with residence times predicted by the model in

MIRD Dose Estimate Report No. 8 (41) for the nonresting population, are shown in Table 5.4. The values are given on a per unit ingested activity basis, with 100% absorption into the infant's bloodstream and biokinetics identical to that of an adult assumed. Table 5.5 shows some published dose estimates for the newborn for ^{99m}Tc (38, 50, 51, 54, 57). All of the authors cited in Table 5.5 assumed that activity in the breast milk was free pertechnetate. Rumble (50) assumed that the kinetics were the same as those of adults, that 50% of the pertechnetate ingested was absorbed, and that 2% of the activity ingested went to the thyroid, with only self-irradiation of the target organs considered. The authors listed in Table 5.5 used the specific absorbed fractions of Hwang et al. (63) for a 10-week-old infant, except for the thyroid and gastrointestinal organs, for which they generated photon-absorbed fractions from the geometric models in MIRD Pamphlet Nos. 3 and 8 (64, 65). Berke et al. (51) scaled adult dose estimates by a factor of 10 to obtain infant dose estimates; they assumed that the thyroid would receive a radiation dose 20 times higher than that received by the total body. Mattsson et al. (54) used S values for the stomach contents irradiating the stomach wall, as calculated by Henrichs et al. (66), and adult values for S values for the stomach wall irradiating the stom-

Table 5.4.

Dose Estimates for the Newborn* for Ingested ^{99m}Tc Pertechnetate

Target Organ	Estimated Radiation Dose (mGy/MBq)
Urinary bladder	0.26
Stomach	0.20
Upper large intestine	0.44
Lower large intestine	0.42
Ovaries	0.068
Testes	0.033
Thyroid†	0.40
Total body	0.032

* Based on residence times in MIRD Dose Estimate Report No. 8 (41) for the nonresting population and pediatric phantom of Cristy and Eckerman (27). One hundred percent of ingested activity was assumed to be absorbed into the bloodstream.

† Does not include nonpenetrating dose contribution from activity in salivary glands but does include penetrating dose contribution from salivary glands.

Table 5.5.

Dose Estimates for the Newborn Reported in the Literature for ^{99m}Tc Ingested in Breast Milk

Target Organ	Estimated Radiation Dose (mGy/MBq)				
	Reference 50	Reference 51	Reference 54	Reference 57	Reference 38
Stomach	0.32		1.2		
Upper large intestine	0.57				
Lower large intestine	0.22				0.54
Gonads			0.048		
Thyroid	0.95	0.81	1.2	0.64	0.92
Total body	0.038	0.041	0.048	0.026	0.038

ach wall. They used the Snyder and Ford S values for the gonads (67). O'Connell and Sutton (57) and James et al. (38) generated S values from absorbed fractions for geometric shapes from MIRD Pamphlet Nos. 3 and 8.

Cristy and Eckerman's phantom and the residence times predicted by the model in MIRD Dose Estimate Report No. 5 (35) were used to establish the dose estimates for ^{131}I for the newborn that are listed in Table 5.6. For these estimates, a maximum thyroid uptake of 25% was assumed; Wellman et al. (34) found that the literature for North American children reflected a mean of about 30%, except during the first 2 weeks of life when values can approach 100%. If we assume that the elimination kinetics do not change with an uptake of more than 25%, these estimates may be scaled to calculate dose estimates for these situations. Wellman et al. (34)

Table 5.6.

Dose Estimates for the Newborn* for Ingested ^{131}I as Sodium Iodide

Target Organ	Estimated Radiation Dose (mGy/MBq)
Stomach	8.2
Small intestine	4.6
Liver	1.5
Ovaries	0.55
Testes	0.44
Thyroid	5700
Total body	3.1

* Based on residence times in MIRD Dose Estimate Report No. 5 (35) and the pediatric phantom of Cristy and Eckerman (27). One hundred percent of the ingested activity was assumed to reach the bloodstream.

also calculated a dose estimate for the thyroid of 5.7×10^3 mGy/MBq (2.1×10^4 rad/mCi) for the newborn, with a 30% thyroid uptake at 24 hours and a 68.1-day effective half-time in the thyroid assumed. This half-time is in agreement with the 65-day half-time used for the longest compartment in the model described in MIRD Dose Estimate Report No. 5. James et al. (38) quoted dose estimates of Wellman and Anger (68) for the thyroid from ^{131}I administration of 4.3×10^3 mGy/MBq (1.6×10^4 rad/mCi).

Cristy and Eckerman's phantom (27) and the residence times predicted by the model in MIRD Dose Estimate Report No. 2 (69) were used to establish the dose estimates for ^{67}Ga for the newborn that are listed in Table 5.7. James et al. (38) generated dose estimates for ^{67}Ga ,

Table 5.7.

Dose Estimates for the Newborn* for Ingested ^{67}Ga Gallium Citrate

Target Organ	Estimated Radiation Dose (mGy/MBq)
Stomach	0.87
Small intestine	0.12
Upper large intestine	1.5
Lower large intestine	3.2
Kidneys	1.1
Liver	1.3
Ovaries	0.75
Spleen	2.1
Testes	0.80
Total body	0.88

* Based on residence times in MIRD Dose Estimate Report No. 2 (69) and the pediatric phantom of Cristy and Eckerman (27). One hundred percent of the ingested activity was assumed to reach the bloodstream.

assuming effective half-times of 70 and 61 hours for the spleen and whole body, respectively. Their radiation dose estimates were 2.1 mGy/MBq (7.8 rad/mCi) and 0.38 mGy/MBq (1.4 rad/mCi) for the spleen and whole body, respectively.

RADIATION HAZARDS INVOLVING RADIOPHARMACEUTICAL ADMINISTRATIONS TO PREGNANT WOMEN

The radiosensitivity of the developing fetus is known to be relatively high, because of the high rate of cell division and the abundance of poorly specialized tissues. Effects of ionizing radiation on the developing embryo and fetus include (a) intrauterine and extrauterine growth retardation, (b) embryonic, fetal, or neonatal death, and (c) congenital malformation. The probability and severity of these symptoms will vary with the absorbed dose and absorbed dose rate to the embryo or fetus, as well as the stage of gestation at which irradiation occurs (see section entitled, "Radiation Risks").

Radiation Dosimetry

Radiation dose to the fetus from administration of radiopharmaceuticals to the mother may come from two sources: irradiation of the fetus from activity in the individual organs or total body of the mother and irradiation of the fetal tissues from radioactive materials that cross the placenta. The former involves only penetrating radiation; the latter involves both penetrating and nonpenetrating radiation.

As with other radiation dose calculations, estimating radiation doses to the fetus breaks down into two basic problems: determining the metabolic parameters and determining the physical parameters. The first problem involves determining whether the pharmaceutical behavior in the pregnant female differs from that in the normal adult and in what quantities the pharmaceutical or free radioactive label crosses the placenta and enters the fetal metabolism. The second problem involves deriving the appropriate specific absorbed fractions for irradiation of the fetus by activity in the maternal organs and by activity in the fetus itself.

Biologic Parameters

Many researchers have established that iodine in the mother's bloodstream will cross the placenta (70–75). The fetal thyroid begins assimilating iodine by the thirteenth week and continues for the remainder of the gestation. Fetal thyroid avidity for iodide is greater than maternal avidity. At 9 months of age, the organic iodide concentration in the fetal blood is about 75% of that in the mother's; the ratio of fetal to maternal thyroid concentration, however, is about 1.2 at 3 months, 1.8 from 3 months to 6 months, and 7.5 in the last 3 months (76). Watson (77), in reviewing the work of Aboul-Khair et al. (78), decided that a biologic half-time of 24 days for iodine in the fetal thyroid would be the most conservative number which could be derived from their data. This biologic half-time and an infinite biologic half-time were used to establish the dose estimates for ^{131}I that are listed in Table 5.8.

From a review of the literature, Fisher (79) concluded that the placental transfer of T_3 , T_4 , or TSH is very low. Values of fetal radioactivity were less than 1% of the injected activity in the mother near term and not measurable early in gestation. Kearns and Hutson (75) found that although iodine administered as sodium iodide shortly before induced labor showed about equal concentration in the mother's and the umbilical cord blood, the transfer of L-thyroxine was around 5%, of D-thyroxine was about 9%, and of L-triiodothyronine or D-triiodothyronine was about 25%.

Table 5.8.

Radiation Dose Estimates to the Fetal Thyroid from ^{131}I , Generated by Watson (77) under Two Assumptions

Fetal Age (mo)	Estimated Radiation Dose (mGy/MBq)	
	$t_{\text{eff}} = 6 \text{ days}$	$t_{\text{eff}} = t_p$
3	240	320
4	510	680
5	600	810
6	1100	1500
7	760	1000
8	570	760
9	460	620

The placental transfer of [$^{99\text{m}}\text{Tc}$]pertechnetate in rats is well documented (80, 81). Hahn et al. (81) reported that 3.5% of the injected activity crossed the rat placenta near term; their estimated dose to the fetus, as determined by the geometric model of Smith and Warner (82) for the embryo, was 5.1–6.2 $\mu\text{Gy/MBq}$ (19–23 mrad/mCi). Wegst et al. (80) reported cumulated activity in the rat fetus and placenta as a function of gestational age; the values for the fetus increased exponentially with age, somewhat in parallel with weight gains. Values in the placenta increased linearly, again in rough parallel to weight gain. These investigators listed dose estimates to the whole fetus, based directly on the observed cumulated activities at early stages of pregnancy and on values derived by use of an extrapolation factor based on a human-to-animal weight ratio. They also quoted fetal radiation dose estimates of Kereiakes et al. (83). The estimated value, extrapolated value, and quoted value from Wegst et al. (80) were 13 $\mu\text{Gy/MBq}$ (48 mrad/mCi), 86 $\mu\text{Gy/MBq}$ (322 mrad/mCi), and 10 $\mu\text{Gy/MBq}$ (37 mrad/mCi), respectively. The extrapolated values may be unnecessarily high; because the cumulated activity gains paralleled weight gains, the cumulated activity per unit weight may be a more meaningful parameter, and a weight-related extrapolation may not be needed. Wegst et al. also found that $^{99\text{m}}\text{Tc}$ distribution was altered during pregnancy. Cumulated activities in the thyroid and ovaries decreased during gestation, although cumulated activity values in the ovaries showed a slight increase at the end of gestation. All values for these organs were lower than values for the nonpregnant rats. Values in the liver increased during gestation from normal values to values about 15% higher than normal.

Wegst et al. also demonstrated placental crossover of $^{99\text{m}}\text{Tc}$ -DTPA in rats (84). Values for the cumulated activity in the fetus and placenta increased exponentially and linearly, respectively, as did the pertechnetate values. This document was still in press at the time of this writing, so more quantitative information and dose estimates were not available. Again, however, they demonstrated altered biodistribution during pregnancy. Cumulated activities in the thyroid increased from normal values to values

30% higher than normal during pregnancy; cumulated activities in the ovaries and liver increased from values lower than normal to values 100% and 40% higher than normal, respectively.

Hayes and Byrd (85) found that ^{67}Ga administered as citrate crossed the hamster placenta in amounts of 0.6% and 1.2% of the administered activity at the ends of the second and third trimesters of gestation, respectively. The concentration, however, decreased, since the increase in activity did not keep up with the weight gain. The authors explained this on the basis of the increasing amounts of ^{67}Ga entering the breast milk in the late stages of gestation. Weiner (86) also found ^{67}Ga transfer to the rat fetus during pregnancy. Activity levels in the placenta were between 0.2% and 0.24% in the first trimester, between 0.75% and 4% in the second trimester, and between 2% and 6% in the third trimester. Activity levels in the fetus were between 0% and 0.25% in the second trimester and between 0.2% and 0.6% in the third trimester. He stated that studies in humans involving inadvertent administrations to pregnant women showed a similar pattern but with higher percentages of transfer.

Hahn et al. (81) also listed placental crossover values and dose estimates to the fetus from $^{99\text{m}}\text{Tc}$ -labeled sulfur colloid, albumin, iron complex, and polyphosphate. The maximum crossover values were 0.05%, 0.03%, 3.6%, and 0.6% of the injected activity, respectively. The associated dose estimates (again as determined by the model of Smith and Warner (82)) were 56 $\mu\text{Gy/MBq}$ (210 mrad/mCi), 30 $\mu\text{Gy/MBq}$ (110 mrad/mCi), 59–96 $\mu\text{Gy/MBq}$ (220–360 mrad/mCi), and 70–89 $\mu\text{Gy/MBq}$ (260–330 mrad/mCi), respectively.

Dyer and Brill (87) measured fetal ^{59}Fe uptake up to about 5 months of gestation, in cases of therapeutic abortions. Activity was measured in dissected liver and spleen samples as well as in the whole fetus. The total percent of activity injected into the mother which appears in the fetus increased from about 0.1% to 3.0% over fetal ages ranging from 9 to 22 weeks, while the percent uptake per gram of fetal body weight decreased from about 0.03% to 0.007%. In the fetal liver and spleen, accumulation also in-

creased with age. In the liver, activity levels varied from about 0.07% to 2.3% from 9 weeks to 22 weeks; and in the spleen, activity levels varied from 0.001% to 0.03% from 13 weeks to 22 weeks. The authors generated dose estimates for the fetus and fetal organs apparently by using the geometrical models in MIRP Pamphlet No. 3 (64) for photon self-absorption in small volumes and by adding the nonpenetrating contribution as well as some penetrating contribution from the mother. Their estimated radiation doses for the whole fetus (per unit injected activity in the mother) ranged from 7.8 mGy/MBq to 10.5 mGy/MBq (29 rad/mCi to 39 rad/mCi); estimates for the liver ranged from 65 mGy/MBq to 120 mGy/MBq (240 rad/mCi to 430 rad/mCi); and estimates for the spleen ranged from 16 mGy/MBq to 51 mGy/MBq (60 rad/mCi to 190 rad/mCi).

Hibbard and Herbert (88) studied fetal uptake of radioiodine following administration of iodinated serum albumin (RISA) to the mother near term. Although there was no activity in the amniotic fluid, the umbilical cord plasma concentration ranged from about 1.5% to 2.5% of the mother's plasma concentration at delivery, with time intervals between injection and delivery ranging from 2 hours to 78 hours. Although separate determinations of free and protein-bound iodine were not made, the authors assumed that the low activity levels indicated that placental crossover was realized only for iodine liberated from the albumin in the mother's system. In a study of the fetal thyroid uptake from administrations of RISA 0.1–35 days before delivery, they observed an asymptotically increasing uptake pattern, when corrected for radioactive decay, which would appear to reflect the steady degradation of RISA in the mother. This uptake would result in the release of free iodide and increase fetal thyroid uptake to some maximum. The equation describing the uptake was:

$$y(t) = 2.05(1 - \exp(-0.58t))\exp(-\lambda t)$$

$$\text{Equation 5.4}$$

where $y(t)$ is the fetal thyroid uptake, in percent of activity injected as RISA, t is the time in days PI, and λ is the radioactive decay constant (day^{-1}). As mentioned, the maximum time be-

tween injection and delivery was 35 days, so this pattern is only clearly established for fetuses older than about 7.5 months. The authors generated dose estimates for the fetal thyroid and gonads for ^{131}I , assuming no biologic removal from the fetal organs. Their dose estimates were 260 mGy/MBq (980 rad/mCi) for the thyroid and 0.38 mGy/MBq (1.4 rad/mCi) for the gonads. Since these estimates consider only physical decay, the result for the fetal thyroid can be directly compared to those of Watson (77) (for 8 and 9 months with $t_{\text{eff}} = t_p$). With Hibbard and Herbert's estimate (88), it is predicted that the dose per unit injected activity as RISA is about 40% of that per unit injected activity as sodium iodide. Since the placental crossover was assumed to be only from iodide released from the RISA molecule, the dose estimates for RISA are probably too high. The maximum uptake used by Watson for 9 months was 3.4% of the sodium iodide administered to the mother; therefore, the prediction that as much as 2% of the activity administered to the mother as RISA could reach the fetal thyroid is probably unjustified.

Sastry et al. (89) generated radiation dose estimates for ^{131}I -HSA, ^{125}I -HSA, $^{99\text{m}}\text{Tc}$ -HSA, and [$^{113\text{m}}\text{In}$]indium chloride, four radiopharmaceuticals formerly used in radionuclide placentalography. The dose estimates were derived from a geometric model representing the fetus at about midterm. Their estimates included contributions from activity in the placenta and uterine wall, for which they developed their own mathematical models. They assumed that for the iodinated compounds, 5% of the iodine was released per day from the RISA molecule, 2% of the total injected activity crossed the placenta, and 5% of the free iodide in either the mother's or the fetus' bloodstream was taken up in the thyroid. For all of the HSA compounds, a 13-day biologic half-time in the blood was assumed. For $^{99\text{m}}\text{Tc}$ -labeled HSA, 13.4% of the injected activity was assumed to appear in the fetal bloodstream. Placental crossover of [$^{113\text{m}}\text{In}$]indium chloride was assumed to be 0.8%, with an effective half-time of 100 minutes in the blood. Their estimates for the whole fetus were 0.57 mGy/MBq (2.1 rad/mCi), 24 $\mu\text{Gy/MBq}$ (87 mrad/mCi), 4.9 $\mu\text{Gy/MBq}$ (18

mrad/mCi), and 4 $\mu\text{Gy/MBq}$ (15 mrad/mCi), respectively, for ^{131}I -, ^{125}I -, and $^{99\text{m}}\text{Tc}$ -labeled HSA and [$^{113\text{m}}\text{In}$]indium chloride. Their respective estimates for the fetal thyroid for the HSA compounds were 98 $\mu\text{Gy/MBq}$ (360 mrad/mCi), 26 $\mu\text{Gy/MBq}$ (98 mrad/mCi), and 12 $\mu\text{Gy/MBq}$ (45 mrad/mCi). This dose estimate for ^{131}I -labeled HSA is almost 3000 times lower than that of Hibbard and Herbert and seems much more reasonable.

Kaul et al. (90) listed dose estimates for the fetus for $^{99\text{m}}\text{Tc}$ -labeled microspheres, sulfur colloid, gluceptate, and polyphosphate and for [^{67}Ga]gallium citrate. The generated dose estimates to the whole fetus were 1.6 $\mu\text{Gy/MBq}$ (6 mrad/mCi), 1.5 $\mu\text{Gy/MBq}$ (5.6 mrad/mCi), 1.9 $\mu\text{Gy/MBq}$ (7 mrad/mCi), 3.5 $\mu\text{Gy/MBq}$ (13 mrad/mCi), and 0.075 mGy/MBq (0.28 rad/mCi), respectively. Neither this article nor the original source document (91), however, reveals how these estimates were derived.

Physical Parameters

For very early stages of pregnancy, when radiopharmaceuticals may be administered inadvertently, a detailed geometric model may not be necessary to provide a reasonable picture of the dosimetry. First, the placental permeability is low in the early months (46). Second, the fetus itself grows slowly at first, with a rapid upswing occurring after about 3 months (92), so the geometry of the region is not greatly affected in the early weeks. Therefore, normal metabolic parameters are probably appropriate, and an approximate dose to the fetus may be obtained by calculating the dose to the uterus. The best model for this application is probably the 15-year-old phantom of Cristy (26).

After the fetus begins to grow, the specific absorbed fractions for the fetus from maternal organs that are not moved from their original position will probably not change significantly. Snyder (93) has shown that the absorbed fraction varies directly with the mass of the target organ for photon energies above about 50 keV for combinations in which the distance between the source and the target organ does not vary greatly as the mass of the target changes. This means that the specific absorbed fraction will not change. In the pregnant female, however,

many of the organs in the abdominal area will be somewhat repositioned as the fetus grows, and the fetus will come considerably closer to many of these organs. Therefore, quantitative estimates of the changes in specific absorbed fractions for many organs will be difficult to make. A phantom representing the pregnant female is required for Monte Carlo estimation of the absorbed fraction for the fetus at various stages of development.

If the amount of activity that crosses the placenta is known, dose estimates for the fetus from self-contained activity are not difficult to obtain, and the absorbed fraction for nonpenetrating radiations may be assumed to be 1. MIRP Pamphlet No. 3 (64) gives values for photon self-absorption for spheres and ellipsoids of various masses, filled with water and containing a uniform distribution of activity throughout. The S values for the whole fetus, once a geometric model is chosen, can thus be obtained from a knowledge of the decay scheme for the radionuclide. If uptake in individual organs of the fetus is known, dose estimates for these organs may also be derived in a similar manner.

If activity is known to localize in the placenta, the model of Sastry et al. (89) will probably give a good approximation of the dose to the fetus from penetrating radiations. They do not actually give absorbed fractions or specific absorbed fractions, but they describe the general geometric model that can be easily adapted to a specific situation.

Cloutier et al. (94) have generated estimates for absorbed fractions for photon activity in the urinary bladder during pregnancy. They generated a detailed geometric model to simulate the fetus at each month of pregnancy, then ran Monte Carlo simulations for a urinary bladder model designed to fill and void at regular intervals. Their results were expressed for several discrete photon energies. If the amount of radioactivity in the urine can be determined, estimates of the dose to the fetus can be obtained with relative ease.

In summary, current models are adequate to estimate fetal radiation dose from maternal activity during the early stages of pregnancy, at least up to 6–8 weeks. For later stages of preg-

nancy, there are models that can be used to give the radiation dose from activity contained in the urinary bladder, placenta, or the fetus itself; for maternal organs that are not significantly affected by the growing fetus (e.g., brain, thyroid), dose estimates based on the dose to the nonpregnant uterus will constitute a first approximation.

In this area of nuclear medicine, the information about the biologic parameters needed for radiation dose estimation is in approximately equal abundance to that about physical parameters. Although information about the metabolic behavior of some radiopharmaceuticals has been obtained, many remain to be studied, and the question about altered maternal physiology during pregnancy has not been fully addressed, although the animal data from Wegst et al. suggest that this is an important area for study. A few of the current geometric models can give some answers about fetal radiation dose in early pregnancy; much remains to be worked on, however, to improve the dose estimates in the middle and late stages of gestation.

Radiation Risks

During the first 2 weeks of development, the fetus is not susceptible to teratogenic effects induced by ionizing radiation. At this stage, the radiation will either damage many cells, which will result in death, or only damage a few cells, which will allow the fetus to survive without defects. During the next 6 weeks of gestation, vital organs and structures of the body are being formed, and radiation injury may result in major morphological abnormalities. Damage during the remaining time may result in physiological defects or minor morphological abnormalities. Table 5.9 lists some specifics about major events in development of the fetus and the stage of gestation at which they occur.

Obviously, quantitative information available on radiation effects to the fetus comes from either animal studies or inadvertent human exposures. The number of studies related to the internal radiation dose from administered radiopharmaceuticals is even lower, with the bulk of the information involving external irradiation of the fetus. Although the list of abnormalities resulting from in utero radiation exposure is

Table 5.9.
Some Specifics of Organogenesis in the Human Fetus

Time (days)	Event
20-21	Heart appears
21-22	Circulation of blood apparent
32	Limb buds appear
32-35	Major differentiation of heart structures
37	Arm, forearm, and hand recognized
22-40	Development of eye
40	Digits on hand recognizable

very long, the most frequent observations involve microcephaly, when exposure occurs early in pregnancy; central nervous system disorders, when exposure occurs in the first 2 trimesters; and growth retardation. Studies on the offspring of the Japanese bomb survivors who were irradiated while pregnant (39) showed an incidence of microcephaly which was 4 times higher (28%) for irradiation occurring during weeks 4 through 13 of gestation than for that (7%) occurring later. For weeks 6 through 11, the measured incidence was 11% for air doses of 1-9 rads, was 17% for air doses of 10-19 rad, and increased upward to 100% for air doses of more than 100 rad. The tissue doses corresponding to the first two ranges above are about 1.4 rad and 5.7 rad, respectively. Although the 11% incidence was not significantly different from the 4% control frequency, the authors (39) believe that the incidence reflected "part of a dose-effect progression for the sensitive stages." Growth retardation and mental retardation were only observed when doses reached 25 rad.

A few observations have been made after pregnant women were inadvertently given therapeutic administrations of ^{131}I . In one reported case (95), in which the mother received three administrations of 111 MBq (3 mCi) and one administration of 44 MBq (1.2 mCi) during the course of her pregnancy, the child eventually exhibited characteristics consistent with cretinism. These authors related another case of a mother who received radioiodine in the fourth week of pregnancy and whose infant died soon after birth. In several other cases involving ad-

ministration of radioactive iodine to pregnant women, however, the children exhibited only subtle behavioral abnormalities, often with hypothyroidism and low protein-bound iodine levels. These cases also often involved much larger administered activities to the mother.

The placenta is readily permeable to inorganic sodium, potassium, cesium, strontium, and phosphorus. Animal studies indicate that administration of radioactive phosphorus and strontium in sufficiently high amounts may result in fetal death.

Relating the quantity of radiation which will cause a certain endpoint in animals to a similar value in humans is virtually impossible. The patterns of results related to stage of gestation when irradiation occurs show remarkable similarities between animals and humans, however, so qualitative results may be studied with some confidence. Because of the large amount of genetic and environmental variables, a threshold at which teratogenic effects will not occur also is difficult to establish, but patterns in animals and humans indicate that there probably are such thresholds and that they are higher for protracted exposures than for acute exposures.

EFFECTS OF ALTERED BIODISTRIBUTION ON ABSORBED DOSE

Absorbed dose estimates for radiopharmaceuticals usually are calculated from data on distribution and kinetics in some "normal" population. Furthermore, the calculations are made for the Reference Man phantom which has standard body and organ masses (40). These calculations obviously do not apply to individuals of a given population but rather apply to the population as a whole. The Medical Internal Radiation Dose (MIRD) Committee of the Society of Nuclear Medicine and other groups that publish dose estimates have recognized that there are large variations in the distribution of a radiopharmaceutical within a normal population. The recognition of this variability has led to the listing of subpopulations or ranges of values based on uptake for some radiopharmaceuticals. In addition to these normal variations, the effects of anatomic or physiologic abnor-

malities, radiopharmaceutical formulation errors, misadministrations, and drug alterations are considered in this section.

Normal Variation

Most nuclear medicine physicians recognize the differences in the appearance of the same type of scan in different patients. Usually, a pattern of distribution is observed in the "normal" studies. Within this pattern of distribution the uptakes by specific organs will differ as discussed in Chapter 16. These variations can cause significant differences in the absorbed dose from a radiopharmaceutical. Two common examples are the doses from $^{99\text{m}}\text{Tc}$ as sodium pertechnetate and ^{123}I or ^{131}I as sodium iodide. In MIRD Dose Estimate Report No. 8 (41), two populations were defined as having different distributions of $\text{Na}^{99\text{m}}\text{TcO}_4$. The absorbed doses calculated from these distributions reflect these differences. The most striking difference is a factor-of-5 increase in the dose to the stomach wall of the resting population over the nonresting population. Other differences in doses are given in this report but are less than a factor of 2. MIRD Dose Estimate Report No. 5 (35) gives the doses from different isotopes of iodine administered as sodium iodide. The dose to the thyroid from different iodine uptake values in the normal thyroid can be different by a factor of 5. Other variations occur but these are less than a factor of 3, and the doses are of much less consequence than is the dose to the thyroid.

Anatomic or Physiologic Abnormality

The radiation absorbed dose, as a result of changes in distribution brought about by disease, usually is a secondary consideration, since the purpose of administering the radiopharmaceutical is to find or confirm disease. These alterations in distribution, retention, and organ size can, however, change the dose estimates.

Two disease states, in addition to normal, were considered in MIRD Dose Estimate Report Nos. 3 and 4 (42, 43) for $^{99\text{m}}\text{Tc}$ -labeled sulfur colloid and ^{198}Au -labeled colloid. For these two liver disease states, the size of the organs and the distribution of the radiopharmaceuticals change. The organ receiving the highest dose

changes, from the liver in the normal state to the spleen in intermediate-to-advanced diffuse parenchymal liver disease. The magnitude of change for ^{99m}Tc and ^{198}Au is different because of the physical parameters of the two radionuclides.

For a radiopharmaceutical such as ^{67}Ga galium citrate, the dose to normal tissues is reduced when the activity is taken up by tumor, abscess, or a metastatic process. The dose to a tumor from a diagnostic procedure is rarely, if ever, calculated. In the case of tumor, abscess, or metastatic process, the dose to normal tissues is assumed to be the maximum received from the study.

The absorbed dose from studies such as those performed with ^{99m}Tc -labeled red blood cells are affected little by decreased perfusion in certain areas. If there is an abnormality, the absorbed doses can be calculated by modifying the distribution. These calculations, however, are rarely performed on a routine basis.

Radiopharmaceutical Formulation Error

For ^{99m}Tc -labeled compounds, the errors in formulation result in untagged compounds (free pertechnetate) or undesired compounds that cause an alteration in the uptake in the target organ. Generally, these alterations are only annoyances in nuclear medicine studies, but they can cause the absorbed doses to the organs to be altered. If the preparation contains some amount of free pertechnetate and the percentage is known, the dose estimates for the amount of pertechnetate can be easily obtained. In these situations, the absorbed dose to the target organ probably will be reduced and a higher absorbed dose may be delivered to organs not under investigation.

In radiopharmaceutical therapy, formulation errors can have a more serious impact. A formulation error involving ^{90}Y -labeled polystyrene beads for treatment of metastatic liver disease resulted in high red-marrow absorbed doses (44, 45). During this procedure, the ^{90}Y -labeled beads were trapped in the capillary bed after injection in the hepatic artery. Eight patients suffered a rapid drop in white blood cell count shortly after injection of the beads, which

suggests the instability of the ^{90}Y binding to the beads. A test of the stability of this batch performed in rats indicated that, indeed, about 50% of the ^{90}Y activity leached off the labeled beads. Half of this activity (25% of the total administered activity) was assumed to deposit in the bones and bone marrow, which results in a bone marrow dose of about 7 rad/mCi. The injected activities of ^{90}Y ranged from 45 mCi to 85 mCi, with possible total red-marrow doses of up to 400–600 rads. Seven of the 8 patients died within 3 weeks, but these were all terminally ill patients who had already undergone various therapeutic procedures, such as chemotherapy, before the ^{90}Y was administered. In summary, formulation errors can be a serious problem with therapeutic radiopharmaceuticals and can cause differences in absorbed doses from diagnostic radiopharmaceuticals. (Chapter 18 deals more fully with formulation problems and the clinical manifestations.)

Administration Errors

The most common administration error is the infiltrated injection; i.e., the radiopharmaceutical is injected into the tissue around a vein rather than into the vein itself. The absorbed dose to this tissue can be calculated from the dose equation,

$$\bar{D}(r_k) = \sum_h \frac{\bar{A}_h}{m_k} \sum_i \Delta\phi_i(r_k \leftarrow r_h) \quad \text{Equation 5.5}$$

if the cumulated activity, \bar{A}_h , in the injection site is known or can be calculated from the half-time and the amount infiltrated and the mass of the infiltrated dose site, m_k , is also known. The other terms in Equation 5.5 are the same as those in Equations 5.1 and 5.2. These absorbed doses to the injection site can be quite high (~100 rad) if the administered activity is high and the mass of the injection site is small. The calculation becomes more complicated if the radiopharmaceutical slowly diffuses into a larger area and thus constantly changes the mass of the injection site.

Another type of administration error is the injection of particles such as MAA or albumin microspheres into an artery instead of a vein. If

the arm vein was the intended site, the particles are trapped in the capillary bed of the hand. The dose equation (Equation 5.3) can be used for calculating the absorbed dose, provided the cumulated activity and mass of the target area are known. For nonparticulate radiopharmaceuticals, the intraarterial injection usually delays the appearance of the activity in the area being studied.

Injection of the wrong radiopharmaceutical does not fall under the heading of altered distribution, since the distribution may be normal for the radiopharmaceutical given, but is another type of administration error. Usually, the dose estimate has already been calculated for the misadministered drug, so the absorbed dose determination is not a problem. The problem is that organs have been irradiated and no information has been obtained.

Injection of too much or too little of the proper radiopharmaceutical usually is caused by a misreading of the dose calibrator. Because the absorbed dose is directly proportional to the administered activity, the absorbed dose estimate for the misadministration is made accordingly. The administration of too little activity initially can be as serious as the administration of too much; e.g., the administration of 50% of the required activity that results in a poor study and necessitates a repeat study has the same effect as giving 150% of the required activity initially.

Drug Intervention

An increasing number of nuclear medicine studies are being complemented with drug intervention, as is discussed in Chapter 10. These studies are designed to cause an alteration of the radiopharmaceutical distribution corresponding to a specific condition. Because the distribution is changed, the absorbed dose also is changed in proportion to the amount of change in distribution. Calculation of the absorbed dose requires these altered distributions of activity to be determined for individual patients. After the cumulated activities are calculated, the general dose equation (Equation 5.1) could be applied. Determination of the altered distribution is difficult, and calculations of this type are not rou-

tinely performed, probably because the absorbed doses are within the diagnostic range and the benefit to be gained outweighs the risk associated with the radiation dose.

Iatrogenic Alterations by Drug Interaction or Invasive Medical Procedures

The distributions from drug interaction or invasive medical procedures vary considerably from one individual to another. These variations can even mask disease or cause a false positive scan interpretation. For diagnostic studies, usually the absorbed doses will be quite low, but doses in individual patients can be significantly different because of changes in distribution brought about by these iatrogenic alterations. As for all dose calculations, the doses are dependent on the cumulated activities for the different organs. If these values are available, the general dose equation (Equation 5.1) can be used. The uptake and retention in organs are not available or are sketchy, at best, for these and often for normal distributions.

The physical properties for dose calculations (radionuclide emissions, phantoms representing man, etc.), compared with the biologic data available, are relatively well known. Collecting adequate biologic data is difficult and time consuming but is necessary if the dose estimates are to reflect the situation for a given population. (These topics are discussed in more detail in Chapters 14 and 15.)

SUMMARY

From the discussion in this chapter the reader may get the impression that absorbed dose calculations are primarily guesswork. Admittedly, assumptions must be made in some calculations when there are gaps in the available data. These calculations, however, represent an estimate of the true absorbed dose with reasonably sufficient accuracy to assure the physician and regulatory agencies that patients are not receiving excessively high absorbed radiation doses. The MIRD technique appears to be an acceptable method of dose calculations, with individual calculations being only as good as the input information. All possible situations have not been modeled, nor will they ever be, but ab-

sorbed dose estimation can continue to be of use with application of available data, some common sense, and a few reasonable assumptions.

REFERENCES

- Food and Drug Administration: Radioactive new drugs for investigational use. *Fed Reg* 28:183, Jan 8, 1963.
- Food and Drug Administration: Radioactive new drugs: new-drug application requirements. *Fed Reg* 36:21026, Nov 3, 1971.
- Loevinger R, Berman M: *Revised Schema for Calculating the Absorbed Dose from Biologically Deposited Radionuclides*, MIRD Pamphlet No 1, Revised. New York, Society of Nuclear Medicine, 1976.
- Snyder WS, Ford MR, Warner GG, Watson SB: "S", *Absorbed Dose per Unit Cumulated Activity for Selected Radionuclides and Organs*, MIRD Pamphlet No 11. New York, Society of Nuclear Medicine, 1975.
- Snyder WS, Ford MR, Warner GG, Watson SB: *A Tabulation of Dose Equivalent per Microcurie-Day for Source and Target Organs of an Adult for Various Radionuclides*. ORNL 5000, Parts I & II. Contract #W-7405-eng-26. Oak Ridge, TN, Oak Ridge National Laboratory, 1974-1975.
- International Commission on Radiological Protection: Limits for intakes of radionuclides by workers. In: *Annals of the ICRP*, ICRP Publication 30. Supplement to Part 1. New York, Pergamon Press, 1979.
- International Commission on Radiological Protection: Limits for intakes of radionuclides by workers. In: *Annals of the ICRP*, ICRP Publication 30. Supplement to Part 2. New York, Pergamon Press, 1981.
- International Commission on Radiological Protection: Limits for intakes of radionuclides by workers. In: *Annals of the ICRP*, ICRP Publication 30. Supplement A to Part 3. New York, Pergamon Press, 1982.
- International Commission on Radiological Protection: Limits for intakes of radionuclides by workers. In: *Annals of the ICRP*, ICRP Publication 30. Supplement B to Part 3. New York, Pergamon Press, 1982.
- Berman M: *Kinetic Models for Absorbed Dose Calculations*, nm/MIRD Pamphlet No 12. New York, Society of Nuclear Medicine, 1977.
- Roedler HD: Accuracy of internal dose calculations with special consideration of radiopharmaceutical biokinetics. In Watson E, Schlafke-Stelson A, Coffey J, Cloutier R (eds): *Proceedings of Third International Radiopharmaceutical Dosimetry Symposium*, HHS Publication FDA-81-8166. Rockville, MD, BRH, June 1981, pp 1-20.
- Lathrop, KA: Collection and presentation of animal data relating to internally distributed radionuclides. In Watson E, Schlafke-Stelson A, Coffey J, Cloutier R (eds): *Proceedings of Third International Radiopharmaceutical Dosimetry Symposium*, HHS Publication FDA-81-8166. Rockville, MD, BRH, June 1981, pp 198-203.
- Thomas JM, Eberhardt LL: Can results from animal studies be used to estimate dose or low dose effects in humans? In Watson E, Schlafke-Stelson A, Coffey J, Cloutier R (eds): *Proceedings of Third International Radiopharmaceutical Dosimetry Symposium*, HHS Publication FDA-81-8166. Rockville, MD, BRH, June 1981, pp 259-282.
- Tsui BMW, Lathrop KA, Harper PV: Extrapolation from animals to the human for the retention of radiothallium in the blood. In Watson E, Schlafke-Stelson A, Coffey J, Cloutier R (eds): *Proceedings of Third International Radiopharmaceutical Dosimetry Symposium*, HHS Publication FDA-81-8166. Rockville, MD, BRH, June 1981, pp 283-291.
- McAfee JG, Subramanian G: Interpretation of interspecies differences in the biodistribution of radioactive agents. In Watson E, Schlafke-Stelson A, Coffey J, Cloutier R (eds): *Proceedings of Third International Radiopharmaceutical Dosimetry Symposium*, HHS Publication FDA-81-8166. Rockville, MD, BRH, June 1981, pp 292-306.
- Oster ZH, Som P, Atkins HL, Brill AB: Desferal (DFO) induced Ga-67 washout from normal tissue, tumor, and abscess in experimental animals. In Watson E, Schlafke-Stelson A, Coffey J, Cloutier R (eds): *Proceedings of Third International Radiopharmaceutical Dosimetry Symposium*, HHS Publication FDA-81-8166. Rockville, MD, BRH, June 1981, pp 307-317.
- Loberg MD: Application of pharmacokinetic modeling to the radiation dosimetry of hepatobiliary agents. In Watson E, Schlafke-Stelson A, Coffey J, Cloutier R (eds): *Proceedings of Third International Radiopharmaceutical Dosimetry Symposium*, HHS Publication FDA-81-8166. Rockville, MD, BRH, June 1981, pp 318-332.
- Food and Drug Administration: Radioactive new drugs and radioactive biologics. Termination of exemptions. *Fed Reg* 40:31298, July 25, 1975.
- Frankel R, Kavin B: The IND/NDA process. In Watson E, Schlafke-Stelson A, Coffey J, Cloutier R (eds): *Proceedings of Third International Radiopharmaceutical Dosimetry Symposium*, HHS Publication FDA-81-8166. Rockville, MD, BRH, June 1981, pp 625-634.
- Fisher H Jr, Snyder W: *Variation of Dose Delivered by ¹³⁷Cs as a Function of Body Size from Infancy to Adulthood*, ORNL-4007. Oak Ridge, TN, Oak Ridge National Laboratory, 1966, pp 221-228.
- Henrichs K, Kaul A: Strahlenexposition von Kindern und Jugendlichen in der nuklearmedizinischen Diagnostik. *Nuklearmedizin* 19:228-231, 1980.
- Henrichs K, Kaul A, Roedler H: Estimation of age dependent internal dose from radiopharmaceuticals. *Phys Med Biol* 27:775-784, 1982.
- Hwang J, Shoup R, Poston J: *Mathematical Description of a Newborn Human for Use in Dosimetry Calculations*, ORNL/TM-5453. Oak Ridge, TN, Oak Ridge National Laboratory, 1976.
- Hwang J, Shoup R, Warner G, Poston J: *Mathematical Descriptions of a One- and Five-Year Old Child for Use in Dosimetry Calculations*, ORNL/TM-5293. Oak Ridge, TN, Oak Ridge National Laboratory, 1976.
- Jones R, Poston J, Hwang J, et al. *The Development and Use of a Fifteen Year-Old Mathematical Phantom for Internal Dose Calculations*, ORNL/TM-5278. Oak Ridge, TN, Oak Ridge National Laboratory, 1976.
- Cristy M: *Mathematical Phantoms Representing Children of Various Ages for Use in Estimates of Internal Dose*, ORNL/NUREG/TM-367. Oak Ridge, TN, Oak Ridge National Laboratory, 1980.
- Cristy M, Eckerman K: *Specific Absorbed Fractions of Energy at Various Ages from Internal Photon Sources, Parts I-VI*, ORNL/TM-8381-ORNL/TM-8386. Oak Ridge, TN, Oak Ridge National Laboratory, 1984.
- Treves S: Personal communication. Children's Hospital Medical Center, Boston, MA, 1984.
- Rogers B: Nuclear medicine applications in pediatrics. *Appl Radiol* 7(1):155-169, 1978.
- Rhurlbeck W: Postnatal growth and development of the lung. In Murray J, (ed): *Lung Disease—State of the Art (1974-1975)*. New York, American Lung Association, 1976, pp 33-74.
- Davies G, Reid L: Growth of the alveoli and pulmonary arteries in childhood. *Thorax* 25:669-681, 1970.
- Li D, Treves S, Heyman S, et al: Krypton-81m: a better radiopharmaceutical for assessment of regional lung function in children. *Radiology* 130:741-747, 1979.
- Kereiakes J, Wellman H, Simmons G, Saenger E: Radiopharmaceutical dosimetry in pediatrics. *Semin Nucl Med* 2(4):316-327, 1972.
- Wellman H, Kereiakes J, Branson B: Total- and partial-body counting of children for radiopharmaceutical dosimetry data. In Cloutier R, Edwards C, Snyder W (eds): *Medical Radionuclides: Radiation Dose and Effects*. US Atomic Energy Commission Division of Technical Information, June 1970.
- Berman M, Braverman L, Burke J, et al: Summary of current radiation dose estimates to humans from ¹²³I, ¹²⁴I, ¹²⁵I, ¹²⁶I, ¹³⁰I, ¹³¹I, and ¹³²I as sodium iodide. MIRD Dose Estimate Report No 5. *J Nucl Med* 16(9):857-860, 1975.
- Ball F, Wolf R: Zur frage der strahlen-exposition bei der anwendung von radioisotopen im kindesalter. *Monatsschr Kinderheilkd* 115:132-152, 1971.
- Hine G, Brownell G: *Radiation Dosimetry*. New York, Academic Press, 1956.
- James A, Wagner H, Cooke R: *Pediatric Nuclear Medicine*. Philadelphia, WB Saunders, 1974.
- Committee on Biological Effects of Ionizing Radiations: *The Effects on Populations of Exposure to Low Levels of Ionizing Radiation*. Washington, DC, National Academy of Sciences, 1980.
- International Commission on Radiological Protection: *Report of the Task Group on Reference Man*, ICRP Report No 23. Oxford: Pergamon Press, 1975.
- Medical Internal Radiation Dose Committee: Summary of current radiation dose estimates to normal humans from ^{99m}Tc as sodium pertechnetate. MIRD Dose Estimate Report No 8. *J Nucl Med* 17(1):74-77, 1976.
- Medical Internal Radiation Dose Committee: Summary of current radiation dose estimates to humans with various liver conditions from ^{99m}Tc-sulfur colloid. MIRD Dose Estimate Report No 3. *J Nucl Med* 16(1):108A-108B, 1975.
- Medical Internal Radiation Dose Committee: Summary of current radiation dose estimates to humans with various liver conditions from ¹⁹⁸Au-colloridal gold. MIRD Dose Estimate Report No 4. *J Nucl Med* 16(2):173-174, 1975.
- Mantravadi RVP, Spigos DG, Tan WS, et al: Intraarterial yttrium 90 in the treatment of hepatic malignancy. *Radiology* 142:783-786, 1982.
- Hubner KF: personal communication, 1984.
- Guyton A: *Textbook of Medical Physiology*, ed 5. Philadelphia, WB Saunders, 1976.
- Eastman N: *Obstetrics*, ed 11. New York, Appleton-Century-Crofts, 1956.
- Tobin R, Schneider P: Uptake of ⁶⁷Ga in the lactating breast and its persistence in milk: case report. *J Nucl Med* 17(12):1055-1056, 1976.
- Larson S, Schall G: Gallium-67 concentration in human breast milk. *JAMA* 218(2):257, 1971.
- Rumble W: Accidental ingestion of Tc-99m in breast milk by a 10-week-old child. *J Nucl Med* 19(8):913-915, 1978.
- Berke R, Hoops E, Kereiakes J, Saenger B: Radiation dose to breastfeeding child after mother had ^{99m}Tc-MAA lung scan. *J Nucl Med* 14(1):51-52, 1979.
- Heaton B: The build-up of technetium in breast milk following the administration of ^{99m}TcO₄ labelled macroaggregated albumin. *Br J Radiol* 52:149-150, 1979.
- Wyburn J: Human breast milk excretion of radionuclides following administration of radiopharmaceuticals. *J Nucl Med* 14(1):115-117, 1973.
- Mattsson S, Johansson L, Nosslin B, Ahlgren L: Excretion of radionuclides in human breast milk following administration of ¹²⁵I-fibrinogen, ^{99m}Tc-MAA, and ⁵¹Cr-EDTA. In Watson E, Schlafke-Stelson A, Coffey J, Cloutier R (eds): *Proceedings of Third International Radiopharmaceutical Dosimetry Symposium*, HHS Publication FDA-81-8166. Rockville, MD, BRH, June 1981, pp 102-110.
- Ogunleye O: Assessment of radiation dose to infants from breast milk following administration of Tc-99m-pertechnetate to nursing mothers. *Health Phys* 45(1):149-151, 1983.
- Vagenakis A, Abreau C, Braverman L: Duration of radioactivity in milk of a nursing mother following ^{99m}Tc administration. *J Nucl Med* 12(4):188, 1971.
- O'Connell M, Sutton H: Excretion of radioactivity in breast milk following ^{99m}Tc-Sn-polyphosphate. *Br J Radiol* 49:377-379, 1976.
- Palmer K: Excretion of ¹²⁵I in breast milk following administration of labelled fibrinogen. Letter to the editor. *Br J Radiol* 52:672-673, 1979.
- Numberger C, Lipscomb A: Transmission of ¹³¹I to infants through human maternal milk. *JAMA* 150(14):1398-1400, 1952.
- Pullar M, Hartkamp A: Excretion of radioactivity in breastmilk following administration of an ^{113m}indium

- labelled chelate complex. Letter to the editor. *Br J Radiol* 50:(599):846, 1977.
61. Wayne E, Koutras D, Alexander W: *Clinical Aspects of Iodine Metabolism*. Philadelphia, FA Davis, 1964.
 62. Hays M: ^{99m}Tc -pertechnetate transport in man: absorption after subcutaneous and oral administration; secretion into saliva and gastric juice. *J Nucl Med* 14(6):331-335, 1973.
 63. Hwang J, Shoup R, Poston J: *Mathematical Description of a Newborn Human for Use in Dosimetry Calculations*, ORNL/TM 5453. Oak Ridge, TN, Oak Ridge National Laboratory, 1976
 64. Brownell G, Ellett W, Reddy A: *Absorbed Fractions for Photon Dosimetry*, MIRD Pamphlet No 3. New York, Society of Nuclear Medicine, 1968.
 65. Ellett W, Humes R: *Absorbed Fractions for Small Volumes Containing Photon-Emitting Radioactivity*. MIRD Pamphlet No 8. New York, Society of Nuclear Medicine, 1971
 66. Heinrichs K, Kaul A, Krause M: *Age Dependent Values of Specific Absorbed Dose*. Berlin, Klinikum Steglitz Physik und Strahlenschutz (Biophysik), Freie Universität, 1980.
 67. Snyder W, Ford M: Estimation of dose to the urinary bladder and to the gonads. In Cloutier R, Coffey J, Snyder W, Watson E (eds): *Proceedings of Radiopharmaceutical Dosimetry Symposium*. Rockville, MD, HEW Publication FDA-76-8044, 1976, pp 313-350.
 68. Wellman H, Anger R: Radioiodine dosimetry and the use of radionuclides other than ^{131}I in thyroid diagnosis. *Semin Nucl Med* 1:357, 1971.
 69. Cloutier R, Watson E, Hayes R, et al: Summary of current radiation dose estimates to humans from ^{67}Ga , ^{67}Ga , ^{68}Ga , and ^{72}Ga -citrate. MIRD Dose Estimate Report No. 2. *J Nucl Med* 14(10):755-756, 1973.
 70. Chapman E, Corner G, Robinson D, Evans T: The collection of radioactive iodine by the human fetal thyroid. *J Clin Endocrinol*. 8:717, 1948.
 71. Eisenbud M, Mochizuki Y, Laurer G: ^{131}I dose to human thyroids in New York City from nuclear tests in 1962. *Health Phys* 9:1291-1298, 1963.
 72. Evans T, Kretschmar R, Hodges R: Radioiodine uptake studies of the human fetal thyroid. *J Nucl Med* 8:157-165, 1967.
 73. Hodges R, Evans T, Bradbury J, Keetel W: Accumulation of radioactive iodine by human fetal thyroids. *J Clin Endocrinol* 15:661-667, 1955.
 74. Dyer N, Brill A, Glasser S: Maternal-fetal transport and distribution of Fe-59 and I-131 in humans. *Am J Obstet Gynecol* 103:290-296, 1969
 75. Kearns J, Hutson W: Tagged isomers and analogues of thyroxine (their transmission across the human placenta and other studies). *J Nucl Med* 4:453-461, 1963.
 76. Book S, Goldman M: Thyroidal radiation exposure of the fetus. *Health Phys* 29:874-877, 1975.
 77. Watson E: Radiation dose estimates to the human fetal thyroid at various stages of development. *J Nucl Med* 24(5):P95, 1983.
 78. Aboul-Khair S, Buchanan J, Crooks J, Turnbull A: Structure and function of the human fetal thyroid. *Clin Sci* 31:415-424, 1966.
 79. Fisher D: Thyroid function in the fetus and newborn. *Med Clin North Am* 59(5):1099-1107.
 80. Wegst A, Goin J, Robinson R: Cumulated activities determined from biodistribution data in pregnant rats ranging from 13 to 21 days gestation. I. Tc-99m pertechnetate. *Med Phys* 10(6):841-845, 1983.
 81. Hahn V, Brod K, Wolf R: The radiation dose to the fetus during isotope investigations of the mother. *Fortschr Roentgenstr* 132(3):326-330, 1980.
 82. Smith E, Warner G: Estimates of radiation dose to the embryo from nuclear medicine procedures. *J Nucl Med* 17:836-839, 1976.
 83. Kereiakes J, Thomas S, Gelford M, et al: Dose estimation in nuclear medicine. In Fullerton G, Kapp D, Waggner R, Webster E (eds): *Biological Risks of Medical Irradiation*, AAPM Medical Physics Monograph No 5. AAPM, New York, 1980.
 84. Wegst A, Goin J, Robinson R: Cumulated activities determined from biodistribution data in pregnant rats ranging from 13 to 21 days gestation. II. Tc-99m DTPA. *Med Phys* (submitted for publication).
 85. Hayes R, Byrd B: Transfer of Ga-67 from hamster dam to fetus and offspring. In Watson E, Schlakfe-Stelson A, Coffey J, Cloutier R (eds): *Third International Radiopharmaceutical Dosimetry Symposium*, HHS Publication FDA-81-8166. Rockville, MD, BRH, June 1981. pp 447-453.
 86. Weiner R: Personal communication. University of Kansas, April 1984.
 87. Dyer N, Brill A: Maternal-fetal transport of iron and iodide in human subjects. *Adv Exp Med Biol* 27:351-366, 1972.
 88. Hibbard B, Herbert R: Foetal radiation dose following administration of radioiodinated albumin. *Clin Sci* 19:337-344, 1960
 89. Sastry K, Reddy A, Nagaratnam A: Dosimetry in radioisotope placentography. *Indian J Med Res* 64:1527-1536, 1976.
 90. Kaul A, Heinrichs K, Roedler H: Radionuclide biokinetics and internal dosimetry in nuclear medicine. *Ric Clin Lab* 10:629-660, 1980.
 91. Kaul A, Roedler H: *Strahlenexposition des Feten Durch Radiopharmaka Schwangerschaftsabbruch Nach Strahlenexposition Durch Medizinische Massnahmen*. Munich, Kolloquium im Institut für Strahlenschutz der Gesellschaft für Strahlen- und Umweltforschung, 1977.
 92. Gillespie E: Principles of uterine growth in pregnancy. *Am J Obstet Gynecol* 59(5):949-959, 1950.
 93. Snyder W: Estimation of absorbed fraction of energy from photon sources in body organs. In Cloutier R, Edwards C, Snyder W (eds): *Medical Radionuclides: Radiation Dose and Effects*. US Atomic Energy Commission Division of Technical Information, June 1970.
 94. Cloutier R, Smith S, Watson E, et al: Dose to the fetus from radionuclides in the bladder. *Health Phys* 25:147-161, 1973.
 95. Green H, Gareis F, Shepard T, Kelley V: Cretinism associated with maternal sodium iodide I-131 therapy during pregnancy. *Am J Dis Child* 122:247-249, 1971.

6

Considerations and Controversies in the Selection of Radiopharmaceuticals

Henry M. Chilton and Robert J. Cowan

Physical Half-life

When a radiopharmaceutical is selected for a specific study, multiple factors must be considered to ensure that optimum clinical information will be provided with minimum radiation exposure to the patient and laboratory personnel. In this endeavor, certain questions must be considered. What are the nuclear properties of the available radiopharmaceuticals? For the organ to be studied, are there multiple radiopharmaceutical localization pathways? If so, which is best suited to provide the desired diagnostic information? Does the presence of certain clinical factors preclude the use of some radiopharmaceuticals and require the use of others? Do certain radiopharmaceuticals have overriding radiopharmacologic properties which limit their usefulness for the evaluation of certain clinical situations? Finally, how significant are non-clinical properties such as cost, availability, and product formulation? In this chapter, some of these areas and several situations which illustrate the radiopharmaceutical selection process are discussed.

DESIRABLE NUCLEAR PROPERTIES

In the early days of nuclear medicine, radiopharmaceuticals were radioiodinated products with limited clinical applications. Over the past several decades, however, developments in radionuclide production technology and radiochemistry have made available a variety of radiopharmaceuticals prepared from several different radionuclides. Because nuclear properties significantly influence patient radiation dosimetry as well as clinical suitability (1), these areas are of primary importance in the selection of a radiopharmaceutical.

Presently, there are more than 1,500 radionuclides available, with physical half-lives ranging from fractions of a second to as long as several thousand years. The description of an "ideal" physical half-life for any radionuclide is difficult, since this property is largely determined by consideration of radiopharmaceutical uptake and elimination kinetics in the target organ. In practice, however, the physical half-life of any radionuclide must be sufficiently long to ensure that after radiopharmaceutical administration, enough activity remains in the tissue at the time of imaging to obtain adequate clinical information. Generally, radionuclides with very long physical half-lives are undesirable, since their presence in the body after imaging results in additional, unnecessary radiation exposure. Very short-lived radionuclides have limitations: the frequency of air freight shipments of these rapidly decaying radionuclides usually is greater, and relatively larger amounts must be administered in order to assure sufficient activity for imaging. Additionally, if the rate of accumulation in the target organ is slow, short-lived radionuclides may be unsuitable.

Decay Mode and/or Principal Gamma Emission

It is well known that radionuclides which decay by nonparticulate emissions, such as isomeric transition or electron capture, are preferable for clinical use, since relatively lesser local tissue irradiation occurs with these decay modes.

Table 6.1.

Nuclear Properties of Selected Radionuclides and Photopeak Efficiencies in 0.5-inch Sodium Iodide

Radionuclide	Physical Half-life	Principal Emission (keV)	Mean Disintegration (%)	Photopeak Efficiency (%)*
^{99m} Tc	6.0 hr	140	88	91
¹¹¹ In	2.8 days	173	89	82
		247	94	50
¹³¹ I	8.1 days	364	82	30

* Photopeak efficiency, shown for the 0.5-inch NaI (Tl) scintillation crystal, represents the percentage of photons striking crystal which are completely absorbed.

For use with most currently available scintillation camera systems, a principal photon energy of 150 keV is near ideal. Higher energy photons (Table 6.1) have much lower photopeak efficiency (2), while very low energy photons are attenuated by body tissues and are less accessible for external scintillation detection. Additionally, these photons should be monoenergetic. A radiopharmaceutical to be employed in a patient in the presence of another radiopharmaceutical should have a slightly higher energy emission to allow detection with minimal energy interference from the initial radiopharmaceutical.

Since the number of photons emitted during decay (i.e., the abundance) influences the amount of radioactivity that must be administered, radionuclides with useful photons of high abundance are most desirable for scintillation imaging. For some studies, however, the radiopharmaceuticals that have suitable biologic distribution properties may not have a high abundance of usable photons. For example, while the myocardial perfusion agent ²⁰¹Tl has gamma emissions at 135 and 167 keV, their

relatively low abundance (Table 6.2) limits their usefulness for imaging. For this reason, ²⁰¹Tl imaging is performed with use of the Hg x-rays which, although of lower energy than the gamma emissions, are available in sufficiently high abundance for imaging.

^{99m}Tc versus Other Radionuclides

Although ^{99m}Tc has near-ideal imaging properties (Table 6.3), it cannot be employed to label some compounds useful for imaging (3). For this reason, alternative radionuclides such as ⁶⁷Ga, ¹¹¹In, ¹²³I, and ¹²⁷Xe have been used to fill clinical voids. Nevertheless, more than 90% of all diagnostic radiopharmaceuticals are labeled with ^{99m}Tc. The majority of these ^{99m}Tc-labeled agents are prepared by adding generator-produced ^{99m}Tc (as sodium pertechnetate) to reagent "kits" that contain the nonradioactive compound to be labeled as well as any other additives required in the radiolabeling process and/or maintenance of the radiolabeled product. Considerations involving the selection of ^{99m}Tc kit-type radiopharmaceuticals are discussed later in this chapter.

Table 6.2.

Nuclear Properties of Myocardial Perfusion Agent, [²⁰¹Tl]Thallous Chloride*

Principal Emissions	Mean Disintegration (%)
Hg x-rays (68–80 keV)	94.4
Gamma-4 (135 keV)	2.7
Gamma-6 (167 keV)	10.0

* Decay mode = electron capture; $t_{1/2\text{ph}}$ = 73.1 hr.

Table 6.3.

Nuclear Properties of ^{99m}Tc

Physical half-life of 6.0 hr
Generator product from decay of ⁹⁹ Mo
Isomeric transition decay mode
Monoenergetic 140-keV emission (88% abundance)
Low radiation dose constant (0.303 gm-rad/ μ Ci-hr)

BIOLOGICAL FACTORS AFFECTING THE CHOICE OF RADIOPHARMACEUTICALS

In addition to nuclear properties, other factors involved in radiopharmaceutical selection pertain to biologic distribution characteristics. These properties, which include tissue uptake rates, rates of biologic clearance, and other kinetic-type factors, significantly affect radiopharmaceutical usefulness and radiation dosimetry. These characteristics are largely influenced by the localization mechanisms of specific radiopharmaceuticals (refer to Table 3.1, page 35). Some organs contain more than one physiologic pathway or tissue characteristic that can be utilized as a mechanism for radiopharmaceutical localization. With these organs, therefore, it is essential that the correct radiopharmaceutical that enables generation of the desired diagnostic information is chosen.

Mechanisms of Localization of Selected Organ Systems

Liver (Reticuloendothelial System versus Hepatobiliary Imaging)

In the liver, two cell types—Kupffer and hepatocytes—provide different organ uptake mechanisms for hepatic localization. The hepatic reticuloendothelial (RE) Kupffer cells, which phagocytize particles in blood, remove intravenously injected colloids. Since Kupffer cells are uniformly distributed in healthy liver, their appearance, as depicted by scintillation imaging, yields information about liver size, shape, and position. The Kupffer cells constitute the largest proportion of the RE system (85%); since phagocytic RE cells are also found in the spleen (10%) and bone marrow (5%), however, intravenously injected radioactive colloids will also be taken up by these organs (4).

Alternatively, hepatic parenchymal cells (hepatocytes) actively remove blood breakdown products and toxins which are subsequently excreted in bile. Radiopharmaceuticals removed by hepatocytes provide diagnostic information on hepatocyte function and on the patency and integrity of the biliary drainage system. In the early days of nuclear medicine, ¹³¹I-labeled rose

bengal, a lipophilic dye, was employed for hepatobiliary imaging (5). Recently, ¹³¹I-labeled rose bengal has been replaced by ^{99m}Tc-labeled derivatives of iminodiacetic acid (IDA) which have superior imaging and biologic distribution properties (6–8).

Kidney (Renal Imaging)

Since renal function consists of several complex mechanisms, the careful selection of the radiopharmaceutical is essential in order to obtain the desired diagnostic information.

Some radiopharmaceuticals, such as ^{99m}Tc-diethylenetriaminepentaacetic acid (DTPA) are filtered by the kidneys and do not undergo tubular reabsorption or secretion. This type of agent is particularly suitable for evaluation of renal blood flow and for the estimation of glomerular filtration (9). Sodium [^{99m}Tc]pertechnetate is also useful for renal blood flow imaging. The urinary excretion of sodium [^{99m}Tc]pertechnetate is relatively slow, with about 85% of the filtered activity being reabsorbed by the renal tubules (10); therefore, it cannot be employed efficiently for renal function studies.

Radiiodinated *o*-iodohippurate (OIH) also is useful for renal imaging; its distribution properties are markedly different from that of ^{99m}Tc-labeled DTPA or pertechnetate, however. Radiiodinated (either ¹²³I or ¹³¹I) OIH is approximately 80% secreted and 20% filtered and is virtually totally extracted from the blood passing through the kidney (11). This efficient renal clearance makes it a very desirable radiopharmaceutical for estimation of effective renal plasma flow (ERPF) (12).

Static images of renal anatomy can be obtained with radiopharmaceuticals that accumulate in the renal cortex (13). Both ^{99m}Tc-labeled dimercaptosuccinic acid (DMSA) and gluceptate have significant cortical retention and can be used for static renal cortical imaging. Imaging with either radiopharmaceutical usually is performed approximately 2–3 hours postinjection. Generally, the fraction of injected dose of ^{99m}Tc-DMSA which localizes in the renal cortex is much greater than that of ^{99m}Tc-gluceptate

and persists for a much longer period of time (13, 14).

Lung (Perfusion versus Ventilation Imaging)

Because gaseous exchange in lung is a composite function involving both blood flow and ventilation, pulmonary nuclear medicine studies employ radiopharmaceuticals that depict either perfusion or ventilation.

Pulmonary perfusion imaging is performed with use of radiolabeled particles such as ^{99m}Tc -labeled macroaggregated albumin (MAA) or human albumin microspheres (HAM). These particles are larger than red blood cells and will be filtered and trapped in the lungs (by capillary blockade mechanism) immediately following intravenous injection. The appearance of these radiolabeled particles in lungs, provided the particles are homogeneously mixed in blood and almost entirely extracted by the lungs during first passage, provides images of regional pulmonary perfusion (15). Areas of lung which do not receive blood appear as areas of diminished activity. Although perfusion imaging with radiolabeled particles is a sensitive indicator of regional lung blood flow, it is of limited specificity, since changes in pulmonary perfusion can be seen with many diseases of the lung. Greater diagnostic specificity for lung disease usually can be obtained by combining lung ventilation imaging with pulmonary perfusion imaging, since pulmonary emboli often can be distinguished from most other types of lung disease which also produce perfusion defects (16) (Table 6.4).

Among clinicians there is some controversy as to which radiopharmaceutical is superior for ventilation imaging. ^{133}Xe , used since the early

1960s for lung ventilation imaging, is less than ideal, since its principal photon emission of 81 keV cannot readily be distinguished from ^{99m}Tc Compton scatter when the ventilation study follows the ^{99m}Tc perfusion study. For this reason, ^{133}Xe ventilation imaging usually is performed either immediately prior to the ^{99m}Tc perfusion study or on the following day (17). Both ^{127}Xe (17–19) and ^{81m}Kr (20) have principal photon energies higher than that of ^{99m}Tc and can be used for ventilation imaging immediately following an abnormal ^{99m}Tc perfusion study. Both ^{127}Xe and ^{81m}Kr decay by desirable electron capture and provide minimal radiation exposure. The relatively long physical half-life of ^{127}Xe (36.4 days), however, prohibits direct release of expired ^{127}Xe to atmosphere, which thus requires the use of some type of gas-trapping system for physical decay. ^{81m}Kr , on the other hand, is a generator-produced radionuclide with a 13-second physical half-life and may be safely exhaled by the patient directly into the room. Multiple lung views can be obtained, since the patient breathes the gas directly from its generator, but the short physical half-life prevents assessment of "washout" which is a sensitive indicator of obstructive airway disease. Each generator must be replaced daily due to the relatively short parent (^{81}Rb) physical half-life of 4.7 hours. Radioaerosols made from commonly available radiopharmaceuticals, such as ^{99m}Tc -DTPA, also can be used to image lung ventilation function (21). After inhalation, radioaerosol residence time in lung is sufficiently long to permit imaging in multiple views, and since relatively inexpensive radiopharmaceuticals are used, the cost for the agent is minimal. Radioaerosols prepared from ^{99m}Tc are not ideal, since the lung perfusion agent is also a ^{99m}Tc -labeled radiopharmaceutical.

CLINICAL DIFFERENCES RELATED TO BIOLOGIC BEHAVIOR

Among radiopharmaceuticals useful for a particular clinical indication, minor differences in biologic behavior can become major considerations which influence overall suitability. Areas in which these types of differences can affect the clinical selection process along with a discussion of radiopharmaceuticals which ex-

plainly these considerations are presented below.

Differences in Routes of Excretion

The routes of radiopharmaceutical biologic clearance are important, since scintigraphic appearance near the target tissues as a result of normal excretion can potentially obscure the target detectability.

Abscess Imaging: [^{67}Ga]Gallium Citrate versus ^{111}In -labeled White Blood Cells

For the detection of focal inflammatory processes, either [^{67}Ga]gallium citrate or ^{111}In -labeled white blood cells can be used. The gastrointestinal tract is a significant excretion pathway for [^{67}Ga]gallium citrate, however, and radioactivity commonly present in the lower gastrointestinal tract (colon) is frequently seen on scintillation imaging. At times, even with bowel cleansing and repeat images, it may be difficult to distinguish normal colon excretion of gallium from ^{67}Ga localization in an intra-abdominal inflammatory lesion. A newer radiopharmaceutical, ^{111}In -labeled leukocytes (22), also shows considerable accumulation in inflammatory lesions but is not normally excreted by the gastrointestinal system. Because of this characteristic, ^{111}In -labeled leukocytes often are preferred in the search for abdominal or pelvic abscesses (23). Bowel cleansing procedures and repeat images are thus avoided, and false positive interpretations can be prevented.

Differences in Routes of Administration

Thyroid Imaging

Most radiopharmaceuticals are restricted to parenteral administration, and a few, such as sodium [^{99m}Tc]pertechnetate, can be given either orally or parenterally. A very few radiopharmaceuticals, including sodium [^{123}I] or [^{131}I]iodide, are limited to oral administration only. Thyroid studies with sodium [^{131}I]iodide may not be advisable, therefore, in persons who experience difficulty swallowing capsular forms of medicinals. In these patients, it may be necessary to use sodium [^{99m}Tc]pertechnetate, which it may be given intravenously. Alternatively, sodium [^{123}I]iodide could be administered in the form of an oral solution.

Differences in Target Uptake Rates

Although two radiopharmaceuticals may share the same uptake pathway, there may be slight variation in absolute target tissue uptake or rates of uptake which affect the clinical usefulness of these radiopharmaceuticals. Usually, differences in basic pharmacologic properties are responsible for such alterations in localization kinetics.

Thyroid Imaging

As previously mentioned, both radioiodides and sodium [^{99m}Tc]pertechnetate can be used for thyroid imaging. Radioiodide requires 24 hours or more for maximum thyroid accumulation, at which time it is relatively specific for the thyroid tissue and provides high target-to-background ratios. Sodium [^{99m}Tc]pertechnetate, however, reaches maximum uptake as soon as 20 minutes after administration but is much less specific for thyroid tissue.

Although both sodium [^{99m}Tc]pertechnetate and radioiodine are initially "trapped" in the thyroid by similar mechanisms, only radioiodine enters further into the organification cycle by which thyroid hormone is produced. Tissue accumulation of radioiodine is considered a more specific indicator of functioning thyroid tissue. Clinically useful images may be obtained with either sodium [^{99m}Tc]pertechnetate or radioiodine (especially sodium [^{123}I]iodide), and selection is often based on factors such as availability, cost, route of administration, and time of maximal uptake. Because of its better specificity for functioning thyroid tissue, however, radioiodine usually is preferred in the search for functioning metastatic thyroid tumor, in the attempt to locate ectopic thyroid tissue, and in the evaluation of functioning thyroid nodules (24).

Renal Imaging: ^{99m}Tc -DMSA versus ^{99m}Tc -Glucaptate

Both ^{99m}Tc -DMSA and ^{99m}Tc -glucaptate localize in the renal cortex and are useful for obtaining images of renal cortical anatomy. Because ^{99m}Tc -DMSA localizes in the renal cortex to a much greater extent and for a longer period of time than does ^{99m}Tc -glucaptate, it provides a higher radiation dose to renal cortex than does

Table 6.4.

Characteristic Evaluation of Pulmonary Emboli and Chronic-type Obstructive Lung Diseases by Pulmonary Perfusion and Ventilation Imaging

Lung Disease Type	Pulmonary Perfusion Imaging	Pulmonary Ventilation Imaging
Pulmonary emboli	Abnormal	Normal
Chronic obstructive	Abnormal	Abnormal

^{99m}Tc -gluceptate (1.4 rad/mCi for ^{99m}Tc -DMSA versus 0.3 rad/mCi for ^{99m}Tc -gluceptate). For this reason, when ^{99m}Tc -DMSA is used, the amount of activity to be administered is limited to 5 mCi. Since dynamic blood flow imaging often requires the injection of at least 10–15 mCi, ^{99m}Tc -gluceptate is preferred whenever renal blood flow imaging is performed in conjunction with delayed renal imaging.

Hepatobiliary Imaging

During the past few years, several ^{99m}Tc -IDA derivatives have been developed (Table 6.5). All these agents share the same hepatobiliary clearance pathway, yet have different rates of excretion. To date, there is no clear consensus as to which ^{99m}Tc -IDA agent is superior for hepatobiliary imaging, and it has been suggested that actual selection of a ^{99m}Tc -IDA agent might be based on the clinical problem at hand. Although the rapid clearance of these ^{99m}Tc -labeled agents from the liver is largely dependent on hepatocellular integrity, slight structural differences among these agents critically affect the rate of excretion from the hepatocytes into bile (25). In one study (26) in which five different ^{99m}Tc -IDA agents were evaluated in a total of 115 patients, it was believed that agents that clear the hepatobiliary system slower may be most suitable for gallbladder visualization in

suspected acute cholecystitis, since rapidly clearing agents may not always reach a slow-filling gallbladder.

Differences in Rates of Excretion

The amount of radiopharmaceutical remaining in blood and soft tissues can seriously degrade image quality by lowering the target to nontarget ratios. Generally, radiopharmaceuticals that clear rapidly from blood permit (a) higher quality images and (b) imaging to be performed much sooner after radiopharmaceutical administration than do some slower-clearing agents.

Bone Imaging

Since Subramanian introduced the first ^{99m}Tc -labeled bone seeker in 1971 (27), other improved bone-seeking radiopharmaceuticals have followed. The ^{99m}Tc -labeled diphosphonates are the agents of choice for skeletal imaging; compared with previous ^{99m}Tc -labeled radiopharmaceuticals, these agents have greater uptake in bone and more rapid blood clearance (28, 29). The fraction of ^{99m}Tc -labeled bone seekers not taken up by bone is rapidly removed from blood and excreted via glomerular filtration. Presently, the ^{99m}Tc -labeled diphosphonates, medronate (MDP) and oxidronate (HDP), are the most widely used ^{99m}Tc -labeled bone imaging radiopharmaceuticals, with ^{99m}Tc -oxidronate showing slightly better bone uptake and blood clearance (30). Thus far, no major clinical difference has been demonstrated between oxidronate and medronate. One study has shown that their ability to detect skeletal lesions is similar (31).

NONCLINICAL FACTORS AFFECTING RADIOPHARMACEUTICAL SELECTION

In practice, not all considerations in radiopharmaceutical selection involve purely clinical decisions such as the drug-related biodistribution properties of the radiodiagnostic agent or the patient's clinical status. Often, a critical determinant in choosing one radiopharmaceutical over all others might be related to differences in product formulation among com-

mercial products, or limitations in their supply and availability, or cost.

Product Formulation

Today, most ^{99m}Tc -labeled radiopharmaceuticals are available in "kit" form. These kits contain the compound to be labeled as well as any necessary reagents that enhance the labeling reaction or maintain product integrity (i.e., prevent breakdown of the "tagged" radiopharmaceutical). Slight differences in kit formulation can significantly affect radiopharmaceutical usefulness.

For example, antioxidants such as gentisic acid (32) or sodium ascorbate slow the rate of in vitro oxidative degradation of certain ^{99m}Tc -labeled radiopharmaceuticals, which thus maintain the preferred radiolabeled form. The in vitro stabilizing effect of the antioxidant, gen-

tisic acid, on the bone imaging radiopharmaceutical, ^{99m}Tc -oxidronate, is shown in Figure 6.1. Stabilized formulations of ^{99m}Tc -labeled radiopharmaceuticals result in preparations with longer radiolabeled shelf lives and can be economically significant, since kits can be used for longer periods of time before serious degradation which might affect image quality occurs.

Over the past several years, there has been increasing interest in the minimum number of particles that must be injected to obtain an acceptable quality lung perfusion study and, consequently, in the kit formulation of the lung perfusion radiopharmaceuticals ^{99m}Tc -MAA and ^{99m}Tc -HAM. Initially, Duley and Heck (33) reported that no less than 65,000 particles were necessary for optimal lung imaging. More recently, however, it has become apparent that improved resolution of current scintillation

Table 6.5.

Chemical Structures of Several ^{99m}Tc -Labeled Derivatives of Iminodiacetic Acid Which Are Useful for Hepatobiliary Imaging

Basic Structure			
Derivatives	R ₁	R ₂	R ₃
HIDA	-CH ₃	-H	-CH ₃
Diisopropyl	-CH(CH ₃) ₂	-H	-CH(CH ₃) ₂
Diethyl	-CH ₂ CH ₃	-H	-CH ₂ CH ₃
p-Isopropyl	-H	-CH(CH ₃) ₂	-H

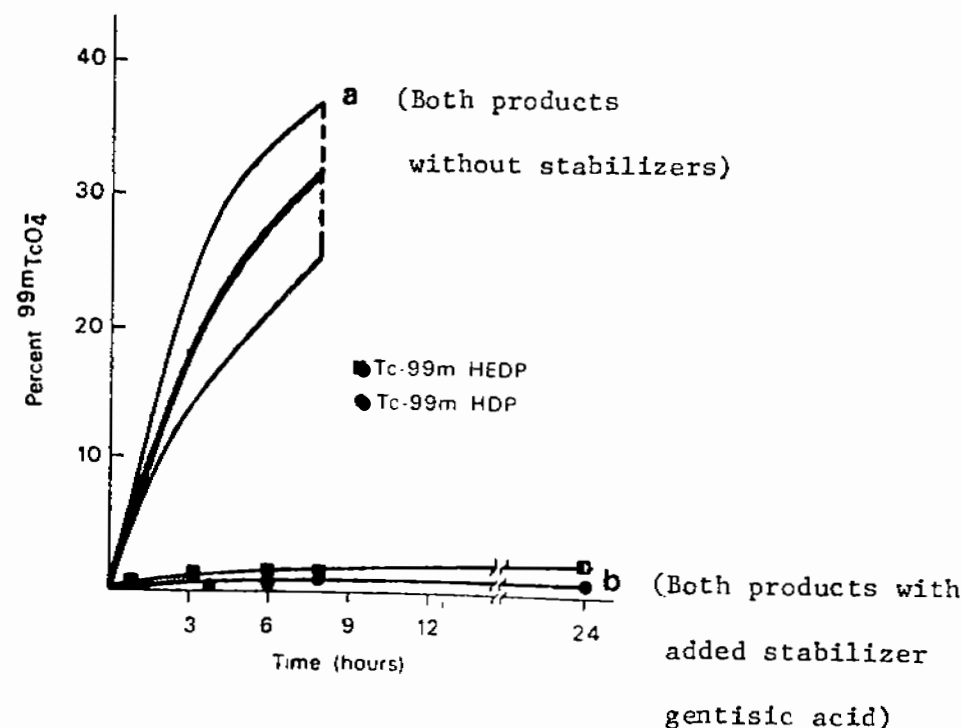

Figure 6.1. Effect of the antioxidant, gentisic acid, on the in vitro stability of two bone-imaging radiopharmaceuticals, ^{99m}Tc -oxidronate (HDP) and ^{99m}Tc -etidronate (HEDP). a, products without stabilizer; b, products with stabilizer. (Adapted from A. J. Tofe et al.: Gentisic acid: a new stabilizer for low tin skeletal imaging agents. Concise communication. *J. Nucl. Med.* 21:366–370, 1980, with permission of the Society of Nuclear Medicine.)

cameras requires an increase in the minimum number of particles to be injected to between 150,000 and 250,000 for an adult. Among the several available commercial preparations of MAA and HAM, there is a wide variation in the number of MAA or HAM particles standardly contained per vial. For larger nuclear medicine departments, the selection of a particular product that contains a relatively small number of particles might necessitate the daily preparation of several vials in order to perform the desired studies in a single day. In this situation, the cost for several vials can be significant.

Sometimes, however, it may be beneficial to use a lung perfusion product that contains small numbers of particles. For example, newborns and infants up to 1 year of age have not fully developed the number of pulmonary capillaries found in the adult, and for this reason, it is necessary to give infants injections of proportionally fewer particles. If, for example, 500,000 particles are considered safe for an adult, lung perfusion scans in newborns should be performed with no more than 50,000 particles, and infants up to 1 year of age should be given injections of no more than 165,000 particles (34, 35).

Ease of in Situ Preparation

Although the ease of in situ preparation may initially appear to be a superficial consideration, a review is important, since time and handling of radiopharmaceuticals during their preparation is likely to, even with extreme precautions, increase personnel radiation exposure.

Patient Preparation Requirements

The optimal use of some radiopharmaceuticals may require patient preparation or some type of drug pretreatment to either enhance radiopharmaceutical uptake or prevent radiopharmaceutical accumulation by certain tissues. Additionally, some preexisting clinical situations may obviate the use of certain radiopharmaceuticals; e.g., radioiodide thyroid imaging cannot be performed satisfactorily in patients receiving antithyroid drugs such as propylthiouracil (PTU). In these situations, however, pertechnetate thyroid imaging is less affected.

Cost

Radiopharmaceutical cost, which is always a worthwhile consideration, is becoming even more significant. Since the amount of radioactivity that may be added to a single vial determines the number of studies that may be performed, cost effectiveness cannot be based only on vial cost. Subsequently, kits that contain large amounts of ligand or complexing agent usually allow the addition of larger activities of ^{99m}Tc during preparation, which permits a larger number of studies to be performed. In these situations, the actual cost per study performed drops substantially. Manufacturer package inserts usually specify suggested maximum levels of [^{99m}Tc]pertechnetate which can be added to each vial during kit preparation.

REFERENCES

- Wagner HN Jr, Emmons H: Characteristics of an ideal radiopharmaceutical. In Andrews GA, Knisely RM, Wagner HN Jr (eds): *Radioactive Pharmaceuticals*, Atomic Energy Commission Symposium Series No 6. Springfield, VA, US Atomic Energy Commission, 1966, pp 1-32.
- Bell EG, Maher B, McAfee JG, et al: Radiopharmaceuticals for gamma cisternography. In Subramanian G, Rhodes BA, Cooper JF, Sodd VJ (eds): *Radiopharmaceuticals*. New York, Society of Nuclear Medicine, 1975, pp 399-410.
- McAfee JG: Radioactive diagnostic agents: current problems and limitations. In Subramanian G, Rhodes BA, Cooper JF, Sodd VJ (eds): *Radiopharmaceuticals*. New York, Society of Nuclear Medicine, 1975, pp 3-14.
- Larson SM, Nelp WB: Radiopharmacology of a simplified ^{99m}Tc -colloid preparation for photoscanning. *J Nucl Med* 7:817-820, 1966.
- Taplin GV, Meredith OM, Kade H: The radioactive (^{131}I -tagged) rose bengal uptake: excretion test for liver function using external gamma-ray scintillation counting techniques. *J Lab Clin Med* 45:665, 1955.
- Loberg MD, Cooper M, Harvey E, et al: Development of new radiopharmaceuticals based upon *N*-substitution of iminodiacetic acid. *J Nucl Med* 17:633-638, 1976.
- Van Wyk AJ, Fourie PJ, Van Zyl WH, et al: Synthesis of five new ^{99m}Tc -HIDA isomers and comparison with ^{99m}Tc -HIDA. *Eur J Nucl Med* 4:445-448, 1979.
- Chervu LR, Nunn AD, Loberg MD: Radiopharmaceuticals for hepatobiliary imaging. *Semin Nucl Med* 12:5-17, 1982.
- Klopper JF, Hauser W, Atkins HL, et al: Evaluation of ^{99m}Tc -DTPA for the measurement of glomerular filtration rate. *J Nucl Med* 13:107-110, 1972.
- Dayton DA, Maher FT, Elveback LR: Renal clearance of technetium (^{99m}Tc) as pertechnetate. *Mayo Clin Proc* 44:539, 1969.
- Tubis M, Posnick E, Nordyke RA: Preparation and use of ^{131}I labeled sodium iodohippurate in kidney function tests. *Proc Soc Exp Biol Med* 103:497-498, 1960.
- Zielinski FW, Holly FE, Robinson GD Jr, et al: Total and individual kidney function assessment with I-123 ortho-iodohippurate. *Radiology* 125:753-759, 1977.
- Arnold RW, Subramanian G, McAfee JG, et al: Comparison of Tc-99m complexes for renal imaging. *J Nucl Med* 16:357-367, 1975.
- Handmaker H, Young B, Lowenstein J: Clinical experience with Tc-99m DMSA (dimercapto succinic acid) a new renal imaging agent. *J Nucl Med* 16:28-32, 1975.
- Davis MA: Particulate radiopharmaceuticals for pulmonary studies. In Subramanian G, Rhodes BA, Cooper JF, Sodd VJ (eds): *Radiopharmaceuticals*. New York, Society of Nuclear Medicine, 1975, pp 267-281.
- McNeil BJ: A diagnostic strategy using ventilation-perfusion studies in patients suspect for pulmonary embolism. *J Nucl Med* 17:613-616, 1976.
- Coates G, Nahmias C: Xenon-127, a comparison with xenon-133 for ventilation imaging. *J Nucl Med* 18:221-225, 1977.
- Hoffer PB, Harper PV, Beck RN, et al: Improved xenon images with Xe-127. *J Nucl Med* 14:172-174, 1973.
- Atkins HL, Susskind H, Klopper JF, et al: A clinical comparison of Xe-127 and Xe-133 for lung ventilation studies. *J Nucl Med* 18:653-659, 1977.
- Fazio R, Jones T: Assessment of regional ventilation by continuous inhalation of radioactive krypton-81m. *Br Med J* 3:673-676, 1975.
- Taplin GV, Poe ND, Isawa T: Radioaerosol inhalation scintigraphy. In Subramanian G, Rhodes BA, Cooper JF, Sodd VJ (eds): *Radiopharmaceuticals*. New York, Society of Nuclear Medicine, 1975, pp 305-315.
- Froelich JW, Swanson DP: Imaging of the inflammatory process with labeled cells. *Semin Nucl Med* 14:128-140, 1984.
- Lantieri RL, Fawcett HD, McKillop JH, et al: Ga-67 or In-111 white blood cell scans for abscess detection: a case of In-111. *Clin Nucl Med* 5:185-188, 1980.
- Task force on short-lived radionuclides for medical applications: evaluation of diseases of the thyroid gland with in vivo use of radionuclides. *J Nucl Med* 19:107-112, 1978.
- Bobba VR, Krishnamurthy GT, Kingston E, et al: Comparison of biokinetics and biliary imaging parameters of four Tc-99m iminodiacetic acid derivatives in normal subjects. *Clin Nucl Med* 8:70-75, 1983.
- Williams W, Krishnamurthy GT, Brar HS, et al: Scintigraphic variations of normal biliary pathology. *J Nucl Med* 25:160-165, 1984.
- Subramanian G, McAfee JG: A new complex of ^{99m}Tc for skeletal imaging. *Radiology* 99:192-196, 1971.
- Subramanian G, McAfee JG, Blair RJ, et al: Technetium-99m-methylene diphosphonate—a superior agent for skeletal imaging: comparison with other technetium complexes. *J Nucl Med* 16:744-755, 1975.
- Davis MA, Jones AG: Comparison of ^{99m}Tc -labeled phosphate and phosphonate agents for skeletal imaging. *Semin Nucl Med* 6:19-31, 1976.
- Bevan JA, Tofe AJ, Benedict JJ, et al: Tc-99m HMDP (hydroxymethylene diphosphonate): a radiopharmaceutical for skeletal and acute myocardial infarct imaging. II. Comparison of Tc-99m hydroxymethylene diphosphonate (HMDP) with other technetium-labeled boneimaging agents in a canine model. *J Nucl Med* 21:967-970, 1980.
- Van Duzee BF, Schaeffer JA, Ball JD, et al: Relative lesion detectability of Tc-99m HMDP and Tc-99m MDP: concise communication. *J Nucl Med* 25:166-169, 1984.
- Tofe AJ, Bevan JA, Fawzi MB, et al: Gentisic acid: a new stabilizer for low tin skeletal imaging agents. Concise communication. *J Nucl Med* 21:366-370, 1980.
- Heck LL, Duley JW Jr: Statistical considerations in lung imaging with ^{99m}Tc -albumin particles. *Radiology* 113:675, 1974.
- Heyman S: Toxicity and safety factors associated with lung perfusion studies with radiolabeled particles (letter to the editor). *J Nucl Med* 20:1098-1099, 1979.
- Davis MD, Taube RA: Re: toxicity and safety factors associated with lung perfusion studies with radiolabeled particles (letter to the editor). *J Nucl Med* 20:1099, 1979.

7

Therapeutic Applications of Radiopharmaceuticals

William J. Baker, Frederick L. Datz, and Robert W. Beightol

Whether a radiopharmaceutical has diagnostic or therapeutic application depends on both the isotope and pharmaceutical used. For diagnostic applications, the isotope should undergo only γ -decay, since usually only γ -radiation is detected by nuclear medicine cameras. The half-life should be just long enough to allow the procedure to be performed. In contrast, the isotope needed for therapeutic purposes should have particulate radiation, such as a β -particle (electron), since these are locally absorbed and increase the local radiation dose. γ -Radiation, which penetrates the tissues, produces less radiation dose than do β -particles. Several references dealing with radioactive decay, particulate interactions, and diagnostic and therapeutic applications of radiopharmaceuticals are available (1-8).

Radiopharmaceuticals can legally be used only by physicians who are qualified by specific training in the safe handling of radionuclides. The experience and training of these physicians must be approved by the Nuclear Regulatory Commission (9) or Agreement State Agency authorized to license the use of radiopharmaceuticals. A list of all byproduct material and procedures is available in the Code of Federal Regulations (9).

Of the many radiopharmaceuticals available for diagnostic and therapeutic use, only those commonly used will be discussed in this chapter.

AGENTS USED FOR THERAPY

Generic Name: Sodium Phosphate P 32 Solution (U.S.P.)
Synonyms: Sodium Phosphate P 32

**Therapeutic by Malinckrodt
 Phosphotope by E. R. Squibb & Sons**

Description

Radiophosphorus (^{32}P) is prepared by (*n, p*) reaction on pure sulfur (^{32}S). ^{32}P has a physical half-life of 14.3 days and decays to ^{32}S by β -emission. The maximum energy of this β -particle is 1.7 MeV, with an average emission energy of 0.695 MeV. In tissue, this β -particle has a maximum range of approximately 8 mm but an average range of only 2 mm.

Sodium [^{32}P]phosphate is available for therapy as a sterile, pyrogen-free, colorless solution containing less than 2 mg of sodium acetate per ml as buffer and sodium chloride for isotonicity. It may contain sodium hydroxide or hydrochloric acid for pH adjustment. The total phosphorus content is less than 0.5 mg/ml. In some instances, autoradiolysis may render the normally colorless solution a pale yellow, but this has no effect on its therapeutic action. The effective half-life of sodium [^{32}P]phosphate is approximately 8 days in the cellular components of blood and 8-10 days in all other tissues except brain and bone.

Mechanism of Action

Certain blood diseases are characterized by an abnormal increase in one or more of the cell lines of the hematopoietic system. Because the myeloproliferative and lymphoproliferative disorders are characterized by a cellular division more rapid than normal, an attempt has been made to interrupt cell multiplication by the use

of radioactive sodium [^{32}P]phosphate. Since sodium [^{32}P]phosphate is deposited primarily in bone and bone marrow, the β -radiation primarily affects the multiplication of bone marrow cells (4, 10).

Indications

Polycythemia vera has been treated with use of phlebotomy, alkylating agents, and sodium [^{32}P]phosphate. Therapy with alkylating agents is often associated with side effects such as nausea, vomiting, alopecia, and skin rashes. Sodium [^{32}P]phosphate, on the other hand, suppresses myeloid proliferation with none of the undesirable side effects associated with the alkylating agents (11-13).

A less common therapeutic application for sodium [^{32}P]phosphate is in the palliative treatment of bone pain in patients with metastases from carcinomas of the prostate, lung, and breast (11-13). Because skeletal metastases generally incite osteoblastic activity and thus phosphate deposition, several researchers have used sodium [^{32}P]phosphate when analgesics, hormone therapy, or external radiation are no longer feasible or effective (14-16).

Dose

For polycythemia vera, the dosage range for the initial treatment is 1-5 mCi, which is dependent on the severity and stage of the disease and the size of the patient. The National Institute of Health Polycythemia Vera Study Group recommends an initial dose of 2.3 mCi of sodium [^{32}P]phosphate per sq m of body surface area. Subsequent doses are based on patient response. After the initial dose, a latent period of 1-3 months usually is succeeded by a smooth progression into complete hematologic remission and achievement of a normal blood count which lasts from months to years (4, 10).

For the treatment of bone pain associated with skeletal metastases, the dosage range is 10-21 mCi of sodium [^{32}P]phosphate given over a 3- or 4-week period, which is dependent on patient response. A typical dosing regimen might be 3 mCi given the first day, followed by two doses of 2 mCi, with each given every other day during the first week. During the second and third weeks, two doses of 2 mCi each are given;

thereafter, 1 mCi is given twice a week until a total of 21 mCi has been administered or the patient's blood count indicates a white blood cell count of less than 3,000/cu mm or a platelet count of less than 50,000/cu mm. In some instances, relief of bone pain is achieved after a total of 8 or 9 mCi has been administered. Reduction of alkaline phosphatase levels and radiologic evidence of bone healing have been associated with the patient's pain relief (14-16). In many instances in which sodium [^{32}P]phosphate is used for the treatment of bone pain, increased incorporation of sodium [^{32}P]phosphate into the bone is achieved by placing the patient on parathormone therapy prior to giving radiophosphorus. The parathormone mobilizes calcium and phosphates out of bone and lowers the threshold of renal tubules for excretion of phosphate, which results in an increased urinary excretion of calcium and phosphorus. On discontinuance of treatment with parathormone, a rebound effect whereby the renal output of calcium and phosphorus is greatly decreased occurs and results in the bones avidly seeking to replace calcium and phosphorus salts, which enhances the incorporation of sodium [^{32}P]phosphate. It has been recommended that calcium be administered concurrently to assist in the deposition of sodium [^{32}P]phosphate in bones and to achieve a progressive ossification of the diseased bone (15).

Toxicity

Because sodium [^{32}P]phosphate is actively deposited in the blood-forming cells of bone, the primary toxic effects are to the hematopoietic system. Overdosage with sodium [^{32}P]phosphate may produce such serious hematological effects as thrombocytopenia, leukopenia, anemia, and leukemia (17, 18).

Pharmacodynamics

About 5-10% of intravenously administered sodium [^{32}P]phosphate is excreted in the urine in the first 24 hours, with about 20% excreted by the end of the first week. Only a very small percentage of the dose is excreted in the feces, but this percentage increases somewhat if the dose is administered orally (17). Once sodium [^{32}P]phosphate is administered, it enters the

body pool of inorganic phosphate and is distributed fairly uniformly throughout the body over the first 3 days. Only 12% of the dose decays during this period. After 3 days, preferential deposition occurs in bone marrow, liver, and spleen, with accumulation of up to ten times as much sodium [^{32}P]phosphate in these tissues as in the rest of the body.

Therefore, these compartments receive a greater amount of radiation-absorbed dose (4). The kinetics of sodium [^{32}P]phosphate require multicompartmental analysis and may differ from patient to patient due to variations in bone accretion, metabolism, and renal excretion (4). The kinetics do not lend themselves to establishing a pharmacokinetic dosing regimen.

Monitoring Parameters

In clinical situations in which sodium [^{32}P]phosphate is being used therapeutically, the most important parameters to be monitored are hematologic (4, 10, 17).

In polycythemia vera, the drug should not be administered if the leukocyte count falls below 5000/cu mm or the platelet count is less than 100,000–150,000/cu mm (4, 17, 18).

In the treatment of bone pain from skeletal metastases, sodium [^{32}P]phosphate usually is not given when the leukocyte count is less than 2,000–5,000/cu mm and/or the platelet count falls below 50,000–100,000/cu mm (14–16, 18, 19).

Generic Name: Chromic Phosphate P 32 (U.S.P.); Chromic Phosphate P 32 Suspension

Synonym: Phosphocol P 32 by Mallinckrodt

Description

Chromic [^{32}P]phosphate is commercially available as a sterile, pyrogen-free suspension in a 30% dextrose solution with 2% benzyl alcohol as a preservative (20). The suspension is a blue-green color with a particle size of 0.5–1.5 μ .

Mechanism of Action

The therapeutic action of chromic [^{32}P]phosphate is accomplished by local irradiation from

the β -emission. Silver (5) has listed several possible mechanisms of action: (a) mesothelial fibrosis, (b) fibrosis of small blood vessels, (c) direct action on tumor seedlings, and (d) direct radiation killing of free tumor cells in fluid.

Previously, ^{198}Au colloid was commonly used. Chromic [^{32}P]phosphate has greater destructive action per disintegration than does gold and avoids the problems of radiation safety associated with the high-energy γ - as well as β -emission of ^{198}Au . Although the literature contains extensive references to its use, ^{198}Au colloid is no longer commercially available in the United States.

Indications

Chromic [^{32}P]phosphate is used for the treatment of peritoneal or pleural effusions caused by metastatic disease and, occasionally, for treatment of primary malignancy. Chromic phosphate is employed by either intracavity instillation (for effusions) or injection directly into the tumor for treatment of the primary malignancy.

Radiocolloids have been used in a large number of malignant diseases, including prostatic (21), bladder (22), lung (23), and cervical carcinomas (24). The only current significant use of ^{32}P is in the management of malignant effusions (6). It should be emphasized that radiocolloids are palliative agents that have no specific effect on the causative malignant process. Chromic [^{32}P]phosphate therapy is indicated in those patients whose effusions fail to respond to conventional radiation therapy or chemotherapy. Therapy is restricted to patients in whom centrifuged effusion specimens have demonstrated malignant cells, since radiocolloids are of no value in the treatment of nonmalignant effusions (4). In bloody effusions, the treatment with radiocolloid may be less effective (20). Palliative success with adequate control of fluid accumulation is reportedly achieved in 50–60% of cases (4).

Dose

The suggested dose range employed in the average 75-kg patient is 10–20 mCi for intraperitoneal instillation and 6–12 mCi for intrapleural instillation. Doses for interstitial use should be based on the estimated gram weight

of the tumor and are about 0.3–0.5 mCi/gm (20).

Toxicity

Therapy with chromic [^{32}P]phosphate is generally well tolerated by most patients, but untoward effects have been associated with its use. These effects include bone marrow depression, pleuritis, nausea, and abdominal cramping. Severe necrosis may occur if chromic phosphate is accidentally injected interstitially or into a loculation (20).

Pharmacodynamics

The physical half-life of chromic [^{32}P]phosphate is 14.3 days; the effective half-life is the same.

Following the removal of fluid from the appropriate cavity, the prescribed dose of radiocolloid is instilled. Care should be taken to ensure that the needle or catheter is in the proper location and that free-flowing fluid is in the cavity. In many institutions, technetium sulfur colloid is given first, to be certain the ^{32}P will not be injected into a loculation. Immediately following administration and for several hours thereafter, the patient should be asked to move from one position to another to help achieve a more homogenous dispersion within the cavity. For the best response, the particles should “plate out” on the surface of the cavity and irradiate the metastatic implants responsible for fluid accumulation. Treatment with chromic phosphate should not be repeated sooner than 3 or 4 weeks if the effusion recurs. Some investigators believe that four instillations should be attempted before the malignant effusion is considered refractory (4).

Monitoring Parameters

All contaminated equipment and intravenous lines used in instillation of the radiopharmaceutical should be handled according to good radiation protection measures. The contaminated supplies should be placed in a safe place and stored until the radioactivity has decayed to background or should be disposed of with other radioactive waste in an accepted manner (25).

Generic Name: Sodium Iodide I 131 Capsules and Solution (U.S.P.)

Synonyms: Sodium Iodide I 131 Capsules and Solution Therapeutic by Mallinckrodt Iodotope I 131 Capsules and Solution by E. R. Squibb & Sons

Description

Sodium [^{131}I]iodide is available in capsules and aqueous solution for oral administration (26–29). The physical half-life of ^{131}I is 8.08 days. The major γ -ray emission is 364 KeV (80%); the predominant β -emission is 608 KeV (87.2%). The final disintegration product is ^{131}Xe . Radioactive iodine (^{131}I) is produced by the fission reaction of ^{235}U or by irradiation of tellurium dioxide. The specific γ -ray constant for ^{131}I is 2.2 R/mCi-hr at 1 cm. The half-value layer is 3 mm of Pb. There is no sterile, pyrogen-free form currently commercially available for intravenous administration. The pH of the commercial solution may differ from the U.S.P. limit of 7.5–9.0. The oral solution and the glass container may darken due to the effects of radiation (27, 29).

The solutions are shipped in lead containers (referred to as “pigs”) to decrease the external radiation. The shielding provided by the manufacturer is generally not adequate, so the “pigs” should be stored behind additional shielding until the radioactive substance is used. Oral solutions of sodium [^{131}I]iodide should be handled with extreme caution, as contamination on the surface of the containers and volatilization can occur (19, 30). In order to decrease radiation dose to personnel, it is good practice to handle all volatile radiopharmaceuticals in an approved fume hood (30).

Mechanism of Action

Sodium [^{131}I]iodide is readily absorbed by the gastrointestinal tract and is handled by the body in the same manner as stable iodide, being removed from the blood stream almost exclusively by the thyroid and kidney. Iodide is concentrated to a lesser extent in the salivary glands and stomach; it reenters the intestinal tract in secretions from these organs and is again absorbed into the circulation. Radioiodine can also be found in nasal secretions, mouth,

trachea, female breast (including the nonlactating breast), gallbladder, liver, and intestine (28).

Indications

Radioactive iodine therapy is indicated in certain patients with carcinomas of the thyroid. Well-differentiated carcinoma of the thyroid, papillary or follicular carcinoma, usually accumulate radioiodine. Although this accumulation is generally significantly less than that in normal thyroid, large doses of radiation can still be delivered by orally administered radioiodine when the normal thyroid is ablated by surgery or radioiodine therapy. Radioiodine will also be accumulated by a small percentage of anaplastic tumors.

Radioactive iodine is also used to treat benign thyroid disease, primarily hyperthyroidism. In fact, ^{131}I is an excellent alternative to long-term antithyroid treatment and has virtually eliminated surgery as a form of therapy in patients with Graves' disease and toxic multinodular goiter.

Dose

The dosage required for a patient usually is determined by the distribution of metastatic disease on an ^{131}I scan. Since uptake of iodine by the tumor tissue is low, patients are allowed to become hypothyroid so that their endogenous TSH will stimulate iodine uptake by the tumor cells. Recent exposure to stable iodine in any form (especially contrast agents used in radiology) or to thyroid medications will decrease the amount of iodine uptake (31). Therefore, a thorough history should be obtained before scanning or treatment.

If the scan shows activity only in the surgical bed, it is difficult to determine whether this represents local tumor or residual thyroid. Some clinicians will treat with 30-mCi doses, assuming that the activity is residual thyroid (32). The 30-mCi dose allows the patient to be treated as an outpatient. A more aggressive approach is to give doses in the range of 100–150 mCi. Usually, patients that show activity in the lungs are treated with 175 mCi, and those with bone metastases are treated with 200 mCi (33).

The dose should always be checked immediately prior to administration. It should be ad-

ministered from the lead container with several rinses of the vial with water.

The dosage for hyperthyroidism varies with its cause. For Graves' disease, a range of 3–10 mCi is used. Although some clinicians attempt to calculate a dose based on the size of the gland and the percent uptake of a tracer amount of iodine, many physicians find a fixed dose to be just as effective. Patients with toxic multinodular goiter are more resistant to therapy and doses in the range of 15–30 mCi are commonly used.

The most common side effect of a radioactive iodine therapy is the gradual development of hypothyroidism. There is no increased incidence of thyroid carcinoma. In fact, treated patients have a lower risk of cancer than the general public. Radioiodine administration is contraindicated in pregnant or nursing mothers.

Toxicity

Potential side effects, although not common, include bone marrow depression, blood dyscrasias, chromosomal abnormalities, and pulmonary fibrosis (28, 29).

Pharmacodynamics

After oral administration of radioiodine, approximately 40% of the activity has an effective half-life of 0.34 days, and 60% has an effective half-life of 7.61 days (29). The main route of excretion is via the kidneys; therefore, the patient should be adequately hydrated to ensure rapid elimination of the iodine that is not incorporated into the tumor.

Monitoring Parameters

Depression of the hematopoietic system may occur when large doses of sodium [^{131}I]iodide are administered. The patient should be followed with appropriate blood tests. Stringent enforcement of all health physics precautions is imperative for protection of personnel and patients. Excellent government publications concerning these precautions are available (34, 35).

REFERENCES

1. Hendee WR: *Medical Radiation Physics*. Chicago, Year Book Medical Publishers, 1970.
2. Mladjenovic M: *Radioisotope and Radiation Physics*. New York, Academic Press, 1973.

3. Parker RP, Smith PHS, Taylor DM: *Basic Science of Nuclear Medicine*. New York, Churchill Livingstone, 1978.
4. Blahd WH: *Nuclear Medicine*. New York, McGraw-Hill, 1971.
5. Silver S: *Radioactive Nuclides in Medicine and Biology: Medicine*, ed 3. Philadelphia, Lea & Febiger, 1968.
6. Maynard CD: *Clinical Nuclear Medicine*. Philadelphia, Lea & Febiger, 1971.
7. Shtasel P: *Speak to Me in Nuclear Medicine*. Hagerstown, MD, Harper & Row, 1976.
8. Subramanian C, Rhodes BA, Cooper JG, Sodd VJ: *Radiopharmaceuticals*. New York, Society of Nuclear Medicine, 1975.
9. Title 10: *Code of Federal Regulations*. Washington, DC, Nuclear Regulatory Commission, Chap 1, Part 35, Sect 35.1–35.100.
10. Wasserman LR, Brown SM: Polycythemia vera. In Holland JF, Frei E III (eds): *Cancer Medicine*. Philadelphia, Lea & Febiger, 1974, pp 1359–1374.
11. Gardner FH: Treatment of polycythemia vera (p. vera). *Semin Hematol* 3:220, 1966.
12. Gilbert HS: Problems relating to control of polycythemia vera: the use of alkylating agents. *Blood* 32:500, 1968.
13. Kenny JM, Marinelli LD, Woodward HQ: Tracer studies with radioactive phosphorus in malignant neoplastic disease. *Radiology* 37:683–687, 1941.
14. Tong ECK, Finkelstein P: The treatment of prostatic bone metastases with parathormone and radioactive phosphorus. *J Urol* 109:71–75, 1973.
15. Tong ECK: Parathormone and P-32 therapy in prostatic cancer with bone metastases. *Radiology* 98:343–351, 1971.
16. Corwin SH, Malament M, Small M: Experiences with P-32 in advanced carcinoma of the prostate. *J Urol* 104:745–748, 1970.
17. ER Squibb & Sons: Technical Data Sheet. Medotopes. Squibb Hospital Division, PO Box 4000, Princeton, NJ 08540.
18. Mallinckrodt: Technical Product Data. Mallinckrodt, St Louis, MO 63184.
19. Silberstein EB: Radionuclide therapy of hematologic disorder. *Semin Nucl Med* 9:100, 1979.
20. Mallinckrodt Nuclear: Phosphocol P-32. Technical Product Data Report 8/76.
21. Rusche C, Jaffe HL: Palliative treatment of prostatic cancer with radioactive colloidal chromic phosphate: three years experience and results. *J Urol* 74:393, 1957.
22. Christensen WR, Weaver RG: Transcystoscopic injection of tumors of the bladder with radioactive colloidal chromic phosphate. *J Int Coll Surg* 28:138, 1957.
23. Hahn PF, Memeely GR, Carlson RI, Alsobrook W: Adjuvant use of silver-coated radioactive gold in treatment of bronchogenic carcinoma by pneumonectomy. *J Nucl Med* 1:273, 1960.
24. Allen WM, Sherman AI, Arneson AN: Further results obtained in the treatment of cancer of the cervix with radiogold: a progress report. *Am J Obstet Gynecol* 70:786, 1955.
25. Title 10: *Code of Federal Regulations*. Washington, DC, Nuclear Regulatory Commission, Chap 1, Part 20.
26. ER Squibb & Sons: Medotope Division, New Brunswick, NJ.
27. ER Squibb & Sons: Technical Data Sheet: Iodotope, Sodium Iodide ^{131}I Capsules and Solution, April 1969.
28. Pochin EE: Radioiodine therapy of thyroid cancer. *Semin Nucl Med* 1(4):503, 1971.
29. Mallinckrodt Nuclear: Sodium Iodide 131-I Capsules and Solution Therapeutic. Technical Product Report, 1/7 1/78.
30. Rubin LM, Miller KL, Schadt WW: A solution to the radioiodine volatilization problem. *Health Phys* 32:307, 1976.
31. Hansten PD: *Drug Interactions*. Philadelphia, Lea & Febiger, 1976.
32. McCowen KD, Adler RA, Ghaed N, et al: Low dose radioiodine thyroid ablation in postsurgical patients with thyroid cancer. *Am J Med* 61:52, 1976.
33. Bierwaltes WH: The treatment of thyroid cancer with radioactive iodine. *Semin Nucl Med* 8:79, 1978.
34. National Council on Radiation Protection and Measurements: *Precautions in the Management of Patients Who Have Received Therapeutic Amounts of Radionuclides*, Report No. 37. National Council on Radiation Protection and Measurements, 1970.
35. Brodsky A: *Principles and Practices for Keeping Occupational Radiation Exposures at Medical Institutions as Low as Reasonably Achievable*, NUREGO267. Washington, DC, Nuclear Regulatory Commission, 1977.

8

Preparation and Clinical Utility of Labeled Blood Products

William J. Baker and Frederick L. Datz

Among the significant advances in nuclear medicine over the past decade, the one that has had probably the greatest clinical impact is the use of radiolabeled red cells, leukocytes, and platelets. Labeled red blood cells (RBC) are used daily in most nuclear medicine departments.

PREPARATION OF RADIOLABELED RED BLOOD CELLS

The agents available for tagging red cells are ^{51}Cr , $^{99\text{m}}\text{Tc}$, and ^{111}In . These agents are indiscriminate and label circulating cells of all ages.

^{51}Cr is the isotope most commonly employed for the measurement of red cell life-span and mass. Red cell labeling with ^{51}Cr has been in use since the early 1950s when Gray and Sterling first described its use (1-4). ^{51}Cr is available as sodium chromate. Because the product has such high specific activity, adequate red blood cell tagging can be obtained with a minimal incubation time. Chromium is available in the hexavalent (+6) state, in which form it readily penetrates the red blood cell, attaches to the hemoglobin, and is reduced to the trivalent (+3) state. The chromium forms a moderately stable label within the red cell until the cell is sequestered. The radiolabel then can elute from the cell and is excreted, mainly in the urine. In the trivalent state, ^{51}Cr is not reutilized in the body for radiolabeling red cells *in vivo*.

The physical half-life of ^{51}Cr is 27.8 days, and the decay occurs mainly by K-capture. Nine percent of total emissions is in the form of a 320-keV γ -ray which, although not ideal for imaging, allows measurements with use of a properly shielded well counter. The effective

half-life is 14.2 days. It should be noted that the biological half-life of red blood cells labeled with ^{51}Cr is significantly longer when the half-life is determined by whole body counting than when it is determined by counting samples of peripheral blood. This implies that the ^{51}Cr label is not promptly excreted at the end of the red cell life-span and that it is probably sequestered in reticuloendothelial organs such as the spleen.

In Table 8.1, the procedure for radiolabeling red blood cells with ^{51}Cr in current use at the Intermountain Radiopharmacy, University of Utah, is detailed. ^{51}Cr -labeled red cells can be utilized for spleen sequestration studies by heating the labeled cell for 20 minutes at 49.5° C. A recent report indicates that the chromium-labeled red cells heated in saline have shorter clearance times than those heated as packed cells or in plasma (5).

Red blood cells labeled with ^{111}In -oxine (oxyquinoline) are used occasionally. The advantage of ^{111}In -oxine-labeled red blood cells is that the physical half-life of ^{111}In of 2.8 days (67.2 hours) allows for serial imaging (6-8). ^{111}In decays by electron capture with 173-keV and 247-keV photons. The radiolabeling of red blood cells with ^{111}In -oxine is relatively easy and requires only that the cell suspension be incubated for approximately 15 minutes with the ^{111}In -oxine solution.

Several methods to radiolabel red blood cells with $^{99\text{m}}\text{Tc}$ are currently available. These methods usually are classified as *in vitro*, *in vivo*, or a combination of both.

The *in vivo* method of radiolabeling red blood cells is based on the observation that the administration of stannous compounds prior to

Table 8.1.
Procedure for Labeling Red Blood Cells with ^{51}Cr

1. Draw 15-20 ml of blood and divide it into two sterile, empty vials (10 ml), each of which contains 2 cc of ACD solution.*
2. Add 25 μCi of sodium [^{51}Cr]chromate to each vial.
3. Incubate (with rotation) for 20 minutes.
4. Add approximately 50 mg of ascorbic acid (0.1 ml of Cervalin, 500 mg/ml) to each vial to stop the reaction.
5. Spin in a centrifuge for 5 minutes at 450 \times g.
6. Vent the vial with a needle.
7. Draw off plasma with a syringe (top half) and save the plasma.
8. Dilute cells with saline up to the 10-ml mark in a vial and mix.
9. Spin again in the centrifuge for 5 minutes.
10. Draw off the saline portion (top half) with a syringe.
11. Measure the wash and plasma (from step 7) in the dose calibrator and calculate labeling efficiency.
12. Resuspend the cells in saline up to an approximate 50% hematocrit (packed cell volume).
13. Dispense the two vials with appropriate paperwork.

* Squibb ACD solution modified, list 10320.

the injection of $^{99\text{m}}\text{Tc}$ -pertechnetate* alters the *in vivo* distribution of the $^{99\text{m}}\text{Tc}$ -pertechnetate (9). Although $^{99\text{m}}\text{Tc}$ -pertechnetate alone does not bind strongly to red blood cells *in vivo*, the pre-tinning of red cells allows the administered $^{99\text{m}}\text{Tc}$ -pertechnetate to enter into the cells, be reduced, and become firmly bound to cellular components (10). The *in vivo* method requires two injections, and no handling of blood is involved. Labeling efficiency ranges from 60% to 90% with use of this method.

If higher labeling efficiencies are necessary, *in vitro* radiolabeling may be used. The *in vitro* method (see Table 8.2) requires the removal of blood from the patient, radiolabeling with $^{99\text{m}}\text{Tc}$, and reinjection into the patient (11, 12).

The combined method utilizes an *in vivo* tinning procedure followed by the addition of $^{99\text{m}}\text{Tc}$ -pertechnetate to a sample withdrawn

*Although sodium [$^{99\text{m}}\text{Tc}$]pertechnetate is preferred by IUPAC, $^{99\text{m}}\text{Tc}$ -pertechnetate is standard, and both are used throughout this chapter.

from the patient, incubation with $^{99\text{m}}\text{Tc}$, and reinjection into the patient (13-16). Acid citrate dextrose (ACD) is the anticoagulant of choice for the combined technique (17). The combined technique is relatively simple and produces uniformly good results.

RADIOLABELED RED CELLS: CLINICAL UTILITY

^{51}Cr -labeled red cells are used infrequently at the present time. They are restricted to studies of red cell survival, red cell mass, and splenic sequestration. In some patients, red cells seem to be destroyed at an accelerated rate. By injection of ^{51}Cr -labeled red cells and then drawing of samples at various times, a curve can be constructed that indicates the average survival time for a red cell. The true mean half-life span of the normal erythrocyte is 50-60 days. However, the ^{51}Cr study gives a normal mean half-life value of only 25-35 days, because about 1% of the label elutes from red cells each day (18).

For a determination of whether the spleen is sequestering red cells, ^{51}Cr -labeled red cells are injected and then activity is measured with a probe placed over the heart and spleen. Increasing counts from the spleen over several days indicate preferential sequestration of red cells (18).

$^{99\text{m}}\text{Tc}$ -labeled red cells are used far more frequently than are ^{51}Cr -labeled cells. The primary use of $^{99\text{m}}\text{Tc}$ -labeled red cells is for cardiovascular studies. With use of a gamma camera interfaced to a computer, a "motion picture" of the heart ejecting the radiolabeled red cells can be obtained. The function of the walls of the heart and the amount of blood ejected can be measured. These studies are useful in diagnosing and evaluating patients with atherosclerotic coronary artery disease, cardiomyopathies, adriamycin cardiotoxicity, valvular heart disease, cardiac shunts, ventricular aneurysms, and myocardial contusions (19).

The other area in which $^{99\text{m}}\text{Tc}$ -labeled red cells are frequently used is in diagnosing sites of gastrointestinal (GI) hemorrhage (13). GI bleeding is often intermittent in nature. Therefore, having $^{99\text{m}}\text{Tc}$ -labeled red cells constantly circulating in the body is an excellent way to

Table 8.2.

Procedure for Preparing ^{99m}Tc -labeled Red Blood Cells (RBC) with Use of the Brookhaven National Laboratory Red Blood Cell Kit*

1. Add 1–3 ml (smallest possible volume is preferable) of sodium [^{99m}Tc]pertechnetate to a sterile and pyrogen-free 10–15-ml pharmaceutical vial and assay. Store in a lead shield.
2. Draw 4 ml of patient blood into a heparinized syringe and add to kit. Up to 6 ml blood may be used if the hematocrit is low.
3. Mix immediately to dissolve the freeze-dried solids in the blood and gently rotate the tube for 5 minutes at room temperature.
4. Add 1 ml of a 4.4% EDTA (ethylenediaminetetraacetic acid, disodium salt) solution. Draw an equal volume of air to avoid pressure buildup in the tube.
5. Mix briefly by gently inverting about five times, and centrifuge the tube upside down for 5 minutes at $1300 \times g$ (2900 rpm for a 14-cm spin radius; full-speed setting on International Clinical Centrifuge Model CL 20928m).
6. Maintain the tube in the inverted position to avoid disturbing the packed RBC. With a standard 20-gauge sterile needle and a $2\frac{1}{2}$ –3-ml sterile disposable syringe, withdraw 1.25–2.0 ml of RBC (depending on volume of whole blood used) and transfer to the premeasured technetium prepared in step 1. To remove the RBC from the upside-down Vacutainer tube, make sure the plunger of the 3-ml syringe is pushed all the way into the syringe barrel before puncturing the Vacutainer stopper— injection of air into the settled RBC will resuspend the cells. Once the needle has just penetrated the Vacutainer stopper, remove the RBC in one smooth plunger withdrawal movement—ejection of cells from the syringe back into the Vacutainer tube will resuspend the remaining cells, and the operation cannot be continued without recentrifugation.
7. Incubate the ^{99m}Tc -RBC mixture for 10 minutes at room temperature with gentle mixing.
8. Assay and dilute appropriately for injection. Cell separation and yield determination at this point consistently give yield of 98% or more.
9. The described procedure yields an excellent agent for blood pool imaging and red cell mass studies. Substitution of the following for step 7 produces an ideal splenic agent: incubate the technetium RBC mixture 15 minutes at 49°C with gentle mixing.

* Use aseptic techniques throughout the procedure. Kits are available from Cadema Medical Products, P. O. Box 250, Middletown, NY 10940.

diagnose GI hemorrhage. The other radiopharmaceutical used for GI bleeding studies, ^{99m}Tc -labeled sulfur colloid, has been shown to be much less effective. This is because the clearance half-time for sulfur colloid is so short and, therefore, intermittent bleeds will be missed. The red cell study is most useful in evaluating lower GI bleeding (colon). Bleeding sites in the upper GI tract (esophagus and stomach) are best diagnosed by endoscopy rather than by radionuclide studies.

Occasionally, ^{99m}Tc -labeled red cells are heat damaged before injection, which causes them to be preferentially taken up by the spleen (20). Studies of heat-damaged red cells are used to diagnose splenomegaly, splenic infarction, tumors of the spleen, hematomas secondary to trauma, and accessory spleens.

PREPARATION OF ^{111}In -LABELED LEUKOCYTES

Since the radioactive agents currently available radiolabel all cell types indiscriminately, it is necessary first to separate the leukocytes from the remainder of the blood cells. Manipulation of the blood in vitro can decrease leukocyte viability, so extreme care must be taken during cell separation.

For clinical examinations such as for abscess detection, mixed leukocyte preparations are adequate. McAfee et al. (21) compared the concentration of a pure preparation of radiolabeled leukocytes to a mixed cell suspension in experimental abscesses and found no significant difference. The simplest way to obtain mixed leukocyte populations is with gravity sedimentation of erythrocytes. For hastening of sedimen-

tation, settling agents such as hydroxyethyl starch can be used.

In studies of neutrophil kinetics, it is imperative that a pure neutrophil population be obtained. Density gradient centrifugation is a commonly used technique (21). Although Ficoll-Hypaque separations have been used extensively, some studies have indicated that this mixture may diminish leukocyte viability (21). This has led some investigators to use a more innocuous gradient material, Percoll.

The pioneering work in leukocyte labeling was performed by McAfee and Thakur in 1976 (22, 23). These investigators looked at a large number of both soluble and particulate agents for labeling neutrophils. In these studies, particulate agents presented several problems, with the major one being that of separating unbound radioactive particles and cells with particles adherent to the surface from those cells that have

engulfed the particles. Soluble agents, on the other hand, allow easy separation of the unwanted activity remaining in the labeling fluid by centrifugation and resuspension of the radiolabeled cells. Of the soluble agents tested, only nonpolar lipid-soluble chelates radiolabeled cells to a sufficient degree. Unfortunately, some of the lipophilic chelates eluted from the cells before intracellular labeling occurred. One that did not, yet radiolabeled cells efficiently, was ^{111}In -oxine. Since ^{111}In -oxine was first determined by McAfee and Thakur to be the best radiolabeling agent, it has gone on to become the most widely used agent for leukocyte labeling.

Several methods for radiolabeling leukocytes with ^{111}In have been reported (24–27). In Table 8.3 the method for radiolabeling leukocytes with ^{111}In -oxine used at the University of Utah Medical Center is described.

Table 8.3.

Procedure for Labeling Autologous Leukocytes with ^{111}In -Oxine

1. Collect 40 cc of whole blood in a 50-cc syringe containing 5 cc of ACD solution and mix well. Add 1 part Hespan (6% Hetastarch, a settling agent) to 10 parts whole blood in the syringe.
2. Place the syringe in a clamp at an 80° angle, with the needle up, and allow the RBC to settle.
3. Remove the needle from the syringe and replace with a butterfly catheter.
4. Take a 50-ml sterile propylene centrifuge tube with a screw top and express the supernatant containing the leukocyte-rich plasma from the syringe into the centrifuge tube, being careful not to collect any RBC.
5. To obtain the white blood cell(s) (WBC) button, centrifuge the supernatant collected in step 4 at $450 \times g$ for 5 minutes. The WBC button will contain some RBC. This is normal and will not affect the preparation.
6. Pour off the leukocyte poor plasma (LPP) and the supernatant into an identical sterile centrifuge tube and save.
7. Resuspend the WBC button by gently adding 5 ml of sterile saline. Agitate very gently to resuspend the WBC button. Spin down and discard the wash.
8. Resuspend with 5 ml of saline and add $650 \mu\text{Ci}$ of ^{111}In -oxine to the concentrated cell suspension and incubate for 20–30 minutes. Gently agitate the mixture three or four times during incubation to ensure adequate mixing.
9. After the incubation is completed, use a 10-ml disposable syringe to withdraw 5 ml of LPP from the tube of step 6, gently add this to the labeled WBC-saline mixture, and agitate gently to resuspend the labeled cells. Centrifuge the mixture for 5 minutes at $450 \times g$. Pour the supernatant into a separate container and count each fraction for labeling efficiency.
10. Assay the wash and cells in the dose calibrator. The labeling efficiency is calculated by the formula: $E = [C/(C + W)] \times 100\%$, where C is the activity associated with the cells, W is the activity associated with the wash, and E is the labeling efficiency.
11. Using a 10-ml syringe, withdraw 6 ml of LPP saved from step 6, add this to the labeled WBC button, and agitate gently to resuspend the labeled cells.
12. The ^{111}In -labeled leukocytes are now ready for injection back into the patient. Save the small amount of labeled cells remaining in the tube for a WBC count and microscopic examination. The amount of activity in the final product should be limited to $500 \mu\text{Ci}$.

The clinical utility of ^{111}In -oxine-labeled leukocytes has stimulated the development of other labeling agents, especially tropolone. Tropolone is another lipophilic chelating agent that, like oxine, forms 3:1 complexes with ^{111}In and can be used to radiolabel neutrophils (28). The radiolabeling technique for ^{111}In -tropolone is similar to that for ^{111}In -oxine (although somewhat simpler and quicker) with one major exception: the cells do not need to be removed from plasma for cell labeling. One method currently in use for ^{111}In -tropolone labeling is given in Table 8.4.

The advantages of ^{111}In -tropolone over ^{111}In -oxine as a labeling agent are controversial. Proponents of tropolone argue that it is less toxic than oxine (28). More importantly, they believe that depriving cells of plasma, as required with

oxine, reduces cell viability. In studies in which ^{111}In -oxine-labeled leukocytes are directly compared with ^{111}In -tropolone-labeled leukocytes, however, no significant difference in their clinical ability to detect abscesses has been noted (29).

^{111}In -oxine is still the prevalent method in use. This agent is no longer an investigational radiopharmaceutical (since January 1986), and therefore, it is available to all physicians licensed to receive ^{111}In .

RADIOLABELED LEUKOCYTES: CLINICAL UTILITY

The primary use of ^{111}In -labeled leukocytes is for the diagnosis of intraabdominal abscesses. These frequently occur as complications of surgery, injuries, or inflammatory diseases of the

GI tract. Less commonly, abscesses result from complications involving the genitourinary system. A mortality rate of 35% or higher is associated with untreated intraabdominal abscesses; therefore, the importance of prompt, accurate detection is obvious. Because an abscess is an accumulation of leukocytes, radiolabeling of the patient's own leukocytes with γ -emitting radionuclides is a (theoretically) logical way to detect these focal infections. Clinical trials have confirmed that leukocyte scanning is a sensitive means of detecting sites of infection. Sensitivities as high as 95% have been reported for scans with ^{111}In -labeled leukocytes (30, 31).

In addition to intraabdominal abscesses, imaging with ^{111}In -labeled leukocytes is helpful in evaluating a number of other disorders. Radiolabeled leukocytes can be used to evaluate patients with inflammatory bowel disease (32). Attempts to use ^{67}Ga gallium citrate in these patients have been suboptimal, since ^{67}Ga is normally excreted in the GI tract. Leukocytes, on the other hand, normally are not excreted in the bowel and, therefore, have a much greater potential for evaluating these diseases. In addition to imaging patients, stools can be collected and counted to follow the activity of the disease (33).

Scans with ^{111}In -labeled leukocytes are occasionally used to diagnose transplant rejection of both the kidneys and the heart, since there is a leukocyte infiltration associated with rejection (34, 35). In addition, radiolabeled leukocytes have been used for diagnosing prosthetic graft infections (36).

The use of ^{111}In -labeled leukocytes in bone and joint infections is controversial. With use of ^{111}In -labeled leukocytes, some investigators have reported very high sensitivities for these infections, whereas others have reported only about 50% sensitivity in their patient populations (37, 38). All investigators, however, have found that when there is bone or joint uptake of radiolabeled leukocytes, it is quite specific for infection.

Imaging with ^{111}In -labeled leukocytes is not useful in suspected pulmonary infection (39). Unfortunately, numerous noninfectious disorders result in leukocyte uptake in the lungs. Only about 50% of patients with focal ac-

cumulation of ^{111}In -labeled leukocytes in the lungs and 10% of patients with diffuse pulmonary uptake of radiolabeled leukocytes actually have an infection.

Finally, the scan does not appear to be helpful in diagnosing infected heart valves (subacute bacterial endocarditis (SBE)) (40). This is significant because SBE is often considered in the differential diagnosis of fever of unknown origin.

PREPARATION OF ^{111}In -LABELED PLATELETS

^{111}In -labeled platelets offer several advantages over ^{51}Cr -labeled platelets: (a) higher photon yield, (b) more desirable imaging energies, and (c) less blood required for labeling. These advantages make ^{111}In a more desirable radionuclide for imaging platelet distribution and quantifying organ uptake. The radiolabeling of platelets with ^{111}In presents greater technical problems than the radiolabeling of leukocytes with ^{111}In . In order to ensure that platelets retain their viability and do not aggregate prior to reinjection, care must be taken during their radiolabeling. Since the original article by Thakur (41), various methods for radiolabeling platelets have appeared in the literature (42-44). The radiolabeling of platelets has been the subject of several symposiums (45, 46). The University of Utah currently utilizes a modification of the method reported by Heaton et al. (43) for the labeling of autologous platelets (Table 8.5).

RADIOLABELED PLATELETS: CLINICAL UTILITY

The utility of radiolabeled platelets has been examined in a variety of diseases. At the present time, however, the role of platelet scintigraphy in routine clinical practice has not been established. Because platelets are an important part of the body's clotting mechanism, it is not surprising that the main interest in using radiolabeled platelets has been in the diagnosis of deep venous thrombosis in the legs. Studies have indicated that ^{111}In -labeled platelets are a sensitive technique for diagnosing fresh clot (47). The degree of uptake of ^{111}In -labeled platelets, however, decreases as the thrombus ages. Therefore, the scan is less useful in patients

Table 8.4.

Preparation of ^{111}In -Tropolone-labeled Leukocytes

1. Collect 40 cc of whole blood in a 50-cc syringe containing 5 cc of ACD solution and mix well.
2. Add 1 part Hespan (6% Hetastarch) to 10 parts whole blood in the syringe.
3. Invert and place the syringe in an incubator (37° C) with the needle up and allow the mixture to settle for 30 minutes.
4. Express leukocyte-rich plasma (LRP) through a 19-gauge butterfly into a 50-ml centrifuge tube.
5. Centrifuge the LRP for 5 minutes at 450 × g.
6. Pour off the supernatant into another 50-ml centrifuge tube labeled platelet poor plasma (PPP).
7. Centrifuge the tube labeled PPP for 5 minutes at 1600 × g.
8. Add 0.1 ml of tropolone solution* (26 µg/0.1 ml in HEPES buffer) to the cell button left over from step 4.
9. Add 700 µCi of ^{111}In -chloride to the button and tropolone solution and resuspend.
10. Incubate the cells in the incubator at 37° C for 10 minutes.
11. "Wash" the cells with 6 ml of the supernatant in the centrifuge tube labeled PPP. This will "scavenge" any free ^{111}In -chloride left in solution.
12. Centrifuge the cells and PPP for 5 minutes at 450 × g.
13. Pour off the supernatant into a tube labeled "wash" and assay it for activity.
14. Resuspend the cell button in 6 ml of PPP.
15. Assay the cells for activity.
16. Determine tagging efficiency.
17. Dispense 500 µCi of activity associated with the leukocytes.
18. Count the number of WBC in a hemocytometer and examine microscopically.

* Preparation of tropolone solution is carried out by following these steps:

1. Dissolve 238.3 mg of HEPES buffer (MW 238.3; Aldrich Chemical, Milwaukee, WI 53201) in 40 ml of normal saline.
2. Add 10 mg of tropolone (MW 122.12; Aldrich Chemical, Milwaukee, WI 53201) and dissolve completely in HEPES solution.
3. Adjust to pH 7.6 with 0.1 N NaOH.
4. Add normal saline up to a volume of 50 ml.
5. Filter 20 ml into a 20-ml sterile evacuated vial with 0.22-µ Millipore filter.
6. Solution is stable for at least 3 months; 0.1 ml of this solution yields 20 µg of tropolone in a 20-ml solution of HEPES buffer.

Table 8.5.

Preparation of ¹¹¹In-labeled Platelets

1. Draw 43 ml of whole blood in 7 ml of ACD.
2. Centrifuge at 200 × g for 15 minutes.
3. Separate platelet-rich plasma and centrifuge at 2000 × g for 10 minutes.
4. Retain plasma.
5. Resuspend platelets in 6 ml of ACD/saline.*
6. Centrifuge at 2000 × g for 10 minutes and discard the rinse solution.
7. Resuspend in 5 ml of ACD/saline and add 800 μCi ¹¹¹In-oxine.
8. Incubate at room temperature for 20 minutes.
9. Add 6 ml of ACD plasma from step 4.
10. Centrifuge at 2000 × g for 10 minutes.
11. Save the wash and calculate labeling efficiency.
12. Resuspend in 5 ml plasma saved from step 4. Radiolabeled platelets are ready for patient use.

* ACD/saline is a 1:7 dilution of Squibb-modified ACD solution with 0.9% NaCl and pH adjusted to 6.5 with 1 M NaOH. The ACD reduces the platelet sensitivity to ADP and is used to decrease the platelet clumping during centrifugation. It is difficult to estimate platelet viability *in vitro*, but aggregation to ADP is somewhat recoverable by adding MgCl₂.

who have clots that are several days old. Platelet uptake appears to be very specific for thrombosis. The optimal time for imaging radiolabeled platelets is 24 hours after injection. The effect of heparin therapy on the scan in deep venous thrombosis is not clear in humans, although there is evidence that it may cause false negative studies (48).

A pulmonary embolus is a blood clot in the extremities which has broken loose and lodged in the lungs. One might think that platelets would be just as useful in this disease as in venous thrombosis of the extremities. Attempts to diagnose pulmonary embolism with radiolabeled platelets, however, have been disappointing (48). It appears that heparin does interfere with uptake of ¹¹¹In-labeled platelets in pulmonary embolism. The need to discontinue use of heparin is a major disadvantage for clinical use of this technique. ¹¹¹In-labeled platelets have been used occasionally in patients with blood clots in other areas, such as in the renal vein and the superior sagittal sinus of the brain (48).

Radiolabeled platelets have been used extensively to examine patients with suspected ather-

osclerosis in the carotid arteries. The results with ¹¹¹In-labeled platelets have been mixed. Despite high expectations, ¹¹¹In-labeled platelets have added little to our understanding of the pathogenesis, diagnosis, or treatment of atherosclerotic disease (48). ¹¹¹In-labeled platelets have not been found to be of much help in the diagnosis of other vascular abnormalities, such as aortic aneurysms (49).

¹¹¹In-labeled platelets appear to be useful in detecting sites of GI hemorrhage in patients who have very low bleeding rates (50). In addition, radiolabeled platelets are used to evaluate the thrombogenicity of various man-made materials that are used in the human body, such as catheters (48).

REFERENCES

1. Gray SJ, Sterling K: Determination of circulating red cell volume by radioactive chromium. *Science* 112:179, 1950.
2. Gray SJ, Sterling K: The tagging of red cells and plasma proteins with radioactive chromium. *J Clin Invest* 29:1604, 1950.
3. Ebaugh FG Jr, Emerson CP, Ross JF: The use of radioactive chromium-51 as an erythrocyte-tagging agent for the determination of red cell survival *in vivo*. *J Clin Invest* 32:1260, 1953.
4. Read RC, Wilson GW, Gardner FH: The use of radioactive sodium chromate to evaluate the life span of the red cell in health and in certain hematological disorders. *Am J Med Sci* 228:40, 1954.
5. Valk PE, Guille J: Measurement of splenic function with heat-damaged RBCs. effect of heating conditions: concise communication. *J Nucl Med* 25:965, 1984.
6. Winzelberg GG, Castronovo FP, Callahan RJ, et al: ¹¹¹In oxine labeled red cells for detection of simulated lower gastrointestinal bleeding in an animal model. *Radiology* 135:455, 1980.
7. Ferrant A, Dehasque N, Leners N, et al: Scintigraphy with In-111-labeled red cells in intermittent gastrointestinal bleeding. *J Nucl Med* 21:844, 1980.
8. Beckman RL, Pittenger GL, Swanson DP, et al: Blood loss measured with indium-111-labeled red blood cells in dogs. *Radiology* 148:243, 1983.
9. McRae J, Sugar RM, Shipley BA, et al: Alterations in tissue distribution of 99mTc pertechnetate in rats given stannous tin. *J Nucl Med* 15:151, 1974.
10. Pavel DG, Zimmer AM, Patterson VN: *In vivo* labeling of red blood cells with 99mTc: a new approach to blood pool visualization. *J Nucl Med* 18:305, 1977.
11. Hill JC, Dworkin JH: Syringe apparatus for radiolabeling cells. *J Nucl Med Tech* 5:32, 1977.
12. Smith TD, Richard P: A simple kit for the preparation of 99mTc-labeled red blood cells. *J Nucl Med* 17:126, 1976.
13. Winzelberg GG, McKusick KA, Froelich JW, et al: Detection of gastrointestinal bleeding with 99mTc-labeled red blood cells. *Semin Nucl Med* 12:139, 1979.
14. Armas R, Thakur ML, Gottschalk A: A simple method of spleen imaging with 99mTc-labeled erythrocytes. *Radiology* 132:215, 1979.
15. Armas RR, Thakur ML, Gottschalk A: A simplified method of selective spleen scintigraphy with Tc-99m-labeled erythrocytes: clinical applications: concise communication. *J Nucl Med* 21:413, 1980.
16. Callahan RJ, Froelich JW, McKusick KA, et al: A modified method for the *in vivo* labeling of red blood cells with Tc-99m: concise communication. *J Nucl Med* 23:315, 1982.
17. Porter WC, Stuart MD, Freitas JE, et al: Acid-citrate-dextrose compared with heparin in the preparation of *in vivo/in vitro* technetium-99m red blood cells. *J Nucl Med* 24:388, 1983.
18. McIntyre P, Dubos PE: The blood. In Rocha AFG, Harbert JC (eds): *Textbook of Nuclear Medicine: Clinical Applications*. Philadelphia, Lea & Febiger, 1979, pp 388-434.
19. Berger HJ, Zaret BJ: Radionuclide assessment of cardiovascular performance. In Freeman LM (ed): *Freeman and Johnson's Clinical Radionuclide Imaging*, ed 3. New York, Grune & Stratton, 1984, pp 364-478.
20. Srivastava SC, Chervu LR: Radionuclide-labeled red blood cells: current status and future prospects. *Semin Nucl Med* 14:68, 1984.
21. McAfee JG, Subramanian G, Gagne G: Technique of leukocyte harvesting and labeling. Problems and perspectives. *Semin Nucl Med* 14:83-106, 1984.
22. McAfee JG, Thakur ML: Survey of radioactive agents for *in vitro* labeling of phagocytic leukocytes. I. Soluble agents. *J Nucl Med* 17:480, 1976.
23. McAfee JG, Thakur ML: Survey of radioactive agents for *in vitro* labeling of phagocytic leukocytes. II. Particles. *J Nucl Med* 17:488, 1976.
24. Thakur ML, Coleman RE, Welch MJ: Indium-111 labeled leukocytes for the localization of abscesses: preparation, analysis, tissue distribution, and comparison with gallium-67 citrate in dogs. *J Lab Clin Med* 89:217, 1977.
25. Beightol RW, Baker WJ: Labeling of autologous leukocytes with indium-111 oxine. *Am J Hosp Pharm* 37:847, 1980.
26. Danpure HJ, Osman S: Cell labeling and cell damage with indium-111 acetylacetonate-an alternative to indium-111 oxine. *Br J Radiol* 54:597, 1981.
27. Danpure HJ, Osman S, Brady F: The labeling of blood cells in plasma with 111-In-tropolonate. *Br J Radiol* 55:247, 1982.
28. Peters AM, Saverymuttu SH, Reavy HJ, et al: Imaging of inflammation with indium-111 tropolonate labeled leukocytes. *J Nucl Med* 24:39, 1983.
29. Datz FL, Baker WJ, Bedont RA, et al: No difference between tropolone and oxine labeled In-111 leukocytes for detecting infection. *J Nucl Med* 26:469, 1985.
30. Baker WJ, Datz FL: Preparation and clinical utility of In-111 labeled leukocytes. *J Nucl Med Tech* 12:131, 1984.
31. Datz FL, Jacobs J, Baker W, et al: Decreased sensitivity of early imaging with In-111 oxine-labeled leukocytes in detection of occult infection. *J Nucl Med* 25:303-306, 1984.
32. Saverymuttu SH, Peters AN, Hodgson HJ, et al: ¹¹¹Indium leukocyte scanning in small bowel Crohn's disease. *Gastrointest Radiol* 8:157-161, 1983.
33. Saverymuttu SH, Peters AN, Lavender P, et al: Quantitative fecal indium-111 labeled leukocyte excretion in the assessment of disease in Crohn's disease. *Gastroenterology* 85:1333-1339, 1983.
34. Forstrum LA, Lahen MK, Cook A, et al: In-111 labeled leukocytes in the diagnosis of rejection and cytomegalovirus infection in renal transplant patients. *Clin Nucl Med* 6:146-149, 1981.
35. Oluwale S, Wang T, Fawwaz R, et al: Evaluation of cardiac allograft with indium-111 labeled cells. *Transplant Proc* 13:1616-1619, 1981.
36. McKeown PP, Miller DC, Jamieson SW, et al: Diagnosis of arterial prosthetic graft infection by indium-111 oxine white blood cell scans. *Circulation* 66(Suppl 1): 130-134, 1982.
37. Raptopoulou V, Doherty PW, Gors TP: Acute osteomyelitis: advantage of white cell scans in early detection. *AJR* 139:1077-1082, 1982.
38. Coleman RE, Welch DM, Baker WJ, et al: Clinical experience using indium-111 labeled leukocytes. In Thakur ML, Gottschalk ML (eds): *Indium-111 Labeled Neutrophils, Platelets and Lymphocytes*. New York, Trivirum, 1980, pp 103-118.
39. Riba AL, Thakur ML, Gottschalk A, et al: Imaging experimental infectious endocarditis with indium-111 labeled blood cellular components. *Circulation* 59:336-343, 1979.
40. Cook PS, Datz FL, Disbro MA, et al: Pulmonary uptake in indium-111 leukocyte imaging: clinical significance in patients with suspected occult infections. *Radiology* 150:557-561, 1984.
41. Thakur ML, Welch MJ, Joist JH, et al: Indium-111 labeled platelets: studies on preparation and evaluation of *in vitro* and *in vivo* functions. *Thromb Res* 9:345, 1976.
42. Dewanjee MK, Rao SA, Didisheim PL: Indium-111 tropolone, a new high affinity platelet label: preparation and evaluation of labeling parameters. *J Nucl Med* 22:981-987, 1981.
43. Heaton WA, Harmon HD, Welch MJ, et al: Indium-111: a new radionuclide label for studying human platelet kinetics. *Br J Haematol* 42:613, 1979.
44. Thakur ML, Barry MJ: Preparation and evaluation of a new indium-111 agent for efficient labeling of human platelets in plasma (111-In-M)* (2-mercaptopyridine 1-oxide). *J Labelled Compd Radiopharm* 19:1411, 1982.
45. Thakur M, Gottschalk A (eds): *Indium-111 Labeled Neutrophils, Platelets, and Lymphocytes*. New York, Trivirum, 1980.
46. Wahner H, Goodwin D (eds): *111-Indium Labeled Platelets and Leukocytes*. Rochester, MN, Society of Nuclear Medicine Central Chapter, 1981.
47. Fenech A, Hussey JK, Smith FW, et al: Diagnosis of

- deep venous thrombosis using antologous indium-111 labeled platelets. *Br Med J* 1:1020-1022, 1981.
48. Cunningham DA, Siegal BA. Radiolabeled platelets. In Freeman LM, Weissman HS (eds): *Nuclear Medicine Annual 1982*. New York, Raven Press, 1982, pp 143-165.
49. Ritchie JL, Stratten JR, Thiele B, et al: Indium-111 platelet imaging for detection of platelet deposition in abdominal aneurysms. *Am J Cardiol* 47:882-889, 1981.
50. Schmidt KG, Rasmussen JW, Grove O, et al: Scintigraphic localization of intermittent gastrointestinal hemorrhage with indium-111-labeled platelets. *Scand J Haematol* 18:444-448, 1983.

Hai Vo
Fall 1991

9

Nuclear Medicine Procedures for Monitoring Patient Therapy

Allan H. Gobuty

One of the most useful endeavors we engage in is to reflect on the quality of our work. This predisposition of looking critically at our accomplishments has assumed importance in medicine only since about 1900 when it became possible to routinely perform serial measurements of blood pressure, pulse, respiratory rate, and body temperature. The advent of cardiopulmonary bypass surgery and the period that followed required more accurate assessment of the cardiovascular and pulmonary status of the patient (1). This requirement led to the clinical use of more sensitive methods of patient evaluation in the late 1950s.

We expect a greater degree of excellence from those who perform tasks repeatedly or who are certified as experts. Until recently, however, there was little notion that we should hold people legally accountable for the proper performance of their work. This was necessarily so, since technology had not yet made it possible to determine how well innovative tasks were being performed until some catastrophic event took place. For example, we could always assume that a ship was constructed safely so long as it remained afloat. In medicine, we may point to the dynamic view of chronic disease described by Bircher (2) as another example. In that account, a long period of time is passed in a stage referred to as compensated dysfunction. Failure occurs after the disease has progressed to the stage of decompensated dysfunction which, in the most serious instances, ends in death (Fig. 9.1). Historically, therefore, task analysis lagged behind innovation. It appeared reasonable that a new idea or technique should capture the day,

The thought that the new idea should be tested against well-established methods of accomplishing the same goal was not fully appreciated, probably because it was painful to look for flaws and because the process of looking appeared to take an inordinate amount of time.

It has been observed (3) that a significant advance in pharmacology occurred when therapeutics was first correlated with clinical effects. Therefore, it appears that what was neglected for so long has in medicine today assumed the importance due it. There is now a zeal for comparing new and old techniques which more than compensates for the earlier neglect. Today, everything is being tested, including the tests themselves. The value of an innovation may now be appreciated by assessing its consequences over a defined period of time. This is accepted today as one concept of *monitoring*. Authoritative dictionaries give 10 to 15 definitions for the term. The most appropriate for this discussion is, "a device for observing a biological condition or function." In many cases, one can monitor the effect of intermittent drug administration, the performance of a surgical procedure, or the state of organ function. Used judiciously, the results have the potential to inform the clinician about the stage and progression rate of disease long before clinical decompensation occurs. This chapter discusses monitoring with use of radionuclides; i.e., how they are being used to assess surgery, drug therapy, organ function, and nutritional procedures. Furthermore, the chapter is designed to place in perspective the rationale for the use of radionuclides as prognostic tools whenever important

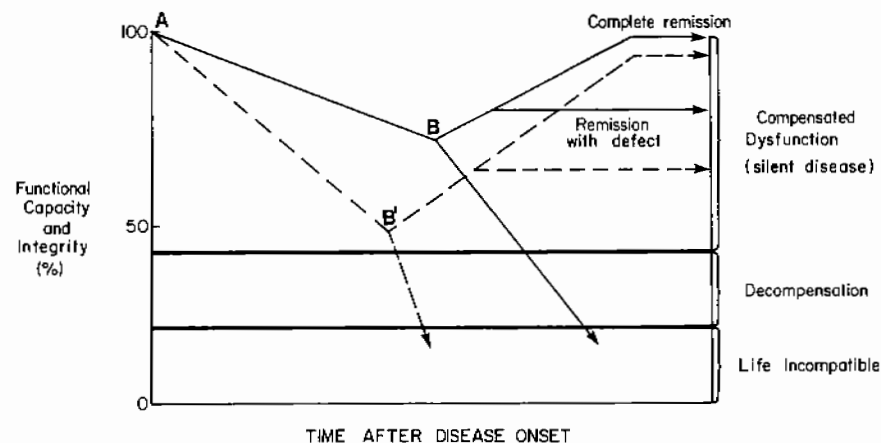

Figure 9.1. Widely accepted stages in the progression of chronic disease in both previously healthy subjects (solid line) and those with preexisting disease (broken line). The time frame between points A, B, and B' represents the stage after disease onset during which prognostic monitoring has been most helpful. (Adapted from J. Bircher: Quantitative assessment of deranged hepatic function: a missed opportunity? *Semin. Liver Dis.* 3:275-284, 1983.)

diagnostic or therapeutic decisions are at stake. Such tests may be called for when invasive diagnostic procedures are indicated, when major surgical or medical therapy is contemplated, or when a decision must be made about instituting nutritional therapy. It is a complex subject. It should appeal especially to practitioners who seek guidelines and references that will assist in determining the appropriateness of using radiotracers as monitoring devices.

CONCEPT OF MONITORING IN NUCLEAR MEDICINE

Radiotracers represent an impressive potential for monitoring. Until recently, creative thinking and the availability of personnel were the only practical limitations to development of monitoring techniques. There was a growing demand for new monitoring methods, which was fueled in part by a growing legal awareness of the indefensibility of not judiciously using all available clinically proven diagnostic and prognostic tools (4). Their rapid introduction led initially to discrepancies, since results of two or more monitoring modalities did not always correlate. There soon came recognition of the importance of evaluating groups of monitoring devices to determine which would be most

appropriate and useful for a given clinical condition.

The literature and clinical experience have both documented a place for nuclear medicine (NM) in monitoring. First, we now recognize a close correlation between increased awareness of how the body responds to disease and the use of radionuclides for monitoring drug, nutritional, and surgical therapy. Second, the choice of an appropriate NM monitoring test depends on knowledge of how the substrate is handled by the organ or system to be tested. A recent review listed over three dozen ways in which NM and nonradioactive drugs are used together for monitoring purposes (5). NM monitoring now assists in identifying patient non-compliance with prescribed therapeutic regimens. Two examples are (a) thyroid function tests for monitoring thyroid medication compliance and (b) gastrointestinal (GI) protein loss studies for monitoring glucocorticoid medication compliance. Life-threatening situations are more effectively dealt with when early trends toward organ system failure can be identified. The intrinsic sensitivity of NM permits detection of many abnormalities at an earlier stage than is possible using equivalent effort with other methods. Examples include scintigraphic

bone surveys to monitor therapy of bone metastases, renal studies to monitor renal function after transplant surgery, and radioisotope studies to monitor changes in myocardial function during drug therapy. Additionally, the nuclear physician can use his monitoring position during consultation as a springboard to better inform his nonnuclear colleagues about other procedures that might be indicated to further clarify the clinical picture. For instance, he frequently has reprints available as handouts to increase confidence in the study result. It appears appropriate, therefore, to consider the monitoring function of NM to be a potentially significant one worthy of increased future effort on the part of the nuclear physician.

The trend today is toward more careful scrutiny of new and complex monitoring methods. This is necessary because of federally mandated cost control measures, matters related to jurisprudence, and the greater need to include data that will permit useful comparisons with established methods. Such conservatism is, in part, a consequence of inadequate and misleading knowledge of both practical drug use and the sequencing of pathology which occurs during a disease process. For example, in NM a patient with suspected GI bleeding is evaluated with use of ^{99m}Tc -labeled red blood cells (RBC), and radioactivity is detected in the colon. Duodenoscopy, however, subsequently identifies blood in the small bowel. The decision is then made to intervene surgically in the small bowel, which contradicts NM findings. It should have been known that the intravenous use of glucagon would have assisted in such cases (6) and that repeated NM studies would have identified the small-bowel bleed. The example points out the complexity of NM monitoring of surgical and drug therapy and the rewards made increasingly available by pharmacologic intervention.

Complications as a result of therapy arise when it is not possible to predict the effect on organ and tissue reserves. Contributions from many disciplines are required to address such conditions. A less-than-appropriate response to therapy may result because of an inability to adequately monitor or evaluate the result. A statistical labyrinth must be negotiated in order

to determine the efficacy of any therapeutic protocol. For instance, in the treatment of thyroid carcinoma for which there are several alternatives, clinicians have sought readily available indices of therapeutic benefits. Here scintigraphy has come to be regarded as an indispensable prognostic tool and as an arbiter of the appropriateness of treatment (7). Thus, adequate monitoring requires a multidisciplinary approach often including NM input in which the nuclear physician is called on to assess the attributes of the scan as well as other data that may be required to make a diagnosis. Figure 9.2 suggests a scheme that depicts the probable areas where various members of the health care team, including the nuclear physician, may interact with the patient and each other to minimize or resolve such therapeutic challenges.

The clinician must recognize that NM may successfully be called on for monitoring and that the methodology is frequently uncomplicated. The clinician should also become well acquainted with the capabilities of the local NM service. An aggressive nuclear physician should have at his disposal a cadre of monitoring capabilities determined by the combined talents of his co-workers, their available time, the present state of technology, and priorities that have been established within the service.

Three of the important areas in NM today, radioassay, imaging, and radiobiology, face practical limitations as to the types of monitoring that may be performed. These limitations are technical and result from imperfectly constructed systems for detecting radioactivity. Measures aimed at addressing them are continuously being devised. For example, as a count rate approaches background, one may question whether true counts or random background variation is being observed. In NM monitoring, the detection of nuclear events is basic to the performance of the studies. In imaging, the minimum specific activity of the tracer should be such that sufficient counts can be obtained during a reasonable performance time of the study. The information obtainable from high specific activity radiopharmaceuticals requires less counting time per study than that obtainable with low specific activity.

With these concepts in mind, we can now

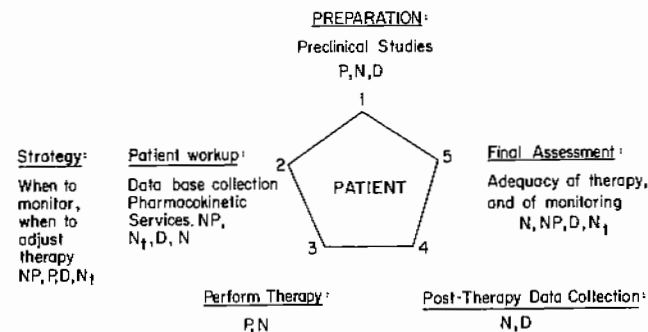

Figure 9.2. Multidisciplinary approach to the application of therapy and subsequent monitoring of the result. Emphasis is placed on areas of interaction with NM personnel. P, nonnuclear physician; NP nuclear physician; D, drug specialist; N, nurse; N₁, nutritionist.

consider the ways in which NM has fit constructively into the monitoring continuum. It will become apparent that NM is most useful when it is providing quantitative data.

From a historical standpoint, the introduction of four NM studies have provided the milestones on which the modern practice of NM monitoring rests. A fifth milestone may soon be reached. The earliest was the introduction of the thyroid uptake test. This study permitted, for the first time, measurements of the functional state of an individual organ. At appropriate intervals the test could be repeated, which would thereby permit the documentation of changes in function that may have occurred as a result of surgical or drug therapy. Bone scanning with ^{99m}Tc-labeled radiopharmaceuticals was first used clinically during the early 1970s. These studies now permit serial evaluation of the progress of therapy for metastatic disease as it affects the involvement of osseous structures. More recently, the ability to quantitatively evaluate the effect of drug and surgical therapy on ventricular function and the assignment of cumulative dose ceilings for the drugs has revolutionized NM myocardial monitoring. Very recently, it has become possible to perform serial studies on intermediary metabolism in the heart and brain with use of positron-emitting radioisotopes. In the near future, a fifth milestone, the ability to target radionuclides to label specific types of circulating blood cells, may be achieved. The vistas opened up by these moni-

toring modalities have been only marginally explored. Their continued successful utilization, however, promises to maintain NM monitoring within the mainstream of medical diagnosis.

Although the examples cited are of in vivo NM, there have been many practical and interesting recent developments in in vitro NM. For instance, radiolabeled metabolic substrates (RMS) have been used to evaluate the effects of substances on sperm motility. Other RMS, including [¹⁴C]glucose and [¹⁴C]fructose, have also been used in other in vitro NM procedures.

For some time there has been interest in the use of drugs for interrupting human fertility (9) to prevent implantation (10) and for determining their effect on sperm metabolism (11, 12). An in vitro method of assessing the effects that frequently used drugs have on sperm metabolic activity was investigated by the author with use of dog and human semen. The purpose of this study was to validate a radiometric method of assessing drug effects on sperm metabolism by liquid-scintillation counting of evolved ¹⁴CO₂. Semen was obtained and placed into 2-ml sterile Dosette vials. Uniformly labeled [¹⁴C]glucose was added to the samples. One of three drugs (isoproterenol, caffeine, or propranolol) was next added, and the system was allowed to incubate for 1 hour at 37° C, after which the samples were counted. Differences between test and control samples were evaluated with use of the Student's *t*-test at the 0.05 level of significance. Test results were reported after normalization of

the data to counts from [¹⁴C]carbon dioxide/10⁹ sperm. The results are presented in Table 9.1. It can be seen from the data that caffeine and isoproterenol increased sperm metabolic activity (except for the effect on sperm noted with 17,900 μg of caffeine, used as a marker of toxicity) and that propranolol decreased it dramatically. Thus it was shown that therapeutic concentrations (as far as can be determined) of the three drugs, when placed in contact with motile sperm under these experimental conditions, have effects on sperm motility that can be evaluated quantitatively and monitored serially.

To what extent these effects would manifest themselves in vivo has not yet been satisfactorily determined. A report by Zipper et al. (9), however, demonstrated that an 80-mg tablet of propranolol is an effective contraceptive when it is inserted vaginally or taken orally. It was found to act, in part, by immobilizing sperm for at least 12 hours. If evidence of the sensitivity of the radiometric method of evaluating the effects of chemical substances on sperm metabolism continues to accumulate, and if a more complete understanding of the relationship between these test results and the fertilizing potential of sperm can be confirmed, the test may prove useful as a new monitoring device.

All of these methods provide information about organ and system function, about specific aspects of bioavailability, and about the effects that therapy may have on these parameters, all of which are recognized monitoring functions.

CLASSIFICATION OF THERAPIES MONITORABLE WITH NUCLEAR MEDICINE

The outline presented in Table 9.2 provides a general overview of the variety of ways in which NM can be used for monitoring. Knowing what to include and what to exclude is one challenge with such lists. In this regard, the large number of uses for radionuclides as tools in research have been omitted because they are not clinically relevant, except indirectly as aids in obtaining experimental data about biological or chemical processes. Another challenge arises because of the different perceptions about what constitutes a relevant NM monitoring test. Impartiality and completeness are best served by including tests that are offered across a worldwide spectrum of NM clinical practice. Liver function testing is included in Table 9.2 not because of popularity but because it is an example of a group of tests that are of considerable interest and potential importance (2). Such tests are discriminated against because there is a widespread belief that with the present technology their utility is limited and their use may constitute an excessive radiation hazard.

RADIONUCLIDES AS PHARMACODYNAMIC TRACERS

The concept of utilizing radioactive tracers to optimize the benefits from drug therapy is not new. Such pharmacokinetic studies have been performed on animals since 1970 (13) and in

Table 9.1.
Effects of Drugs on Sperm*

Drug	μg of Drug per 10 ⁹ Sperm†	Mean cpm (± SD)		
		Test	Control	% Change from Control‡
Isoproterenol	1.11	3639 (485)	2933 (400)	(+) 24.1
Isoproterenol	15.69	2475 (403)	1893 (567)	(+) 30.8
Caffeine	170.94	2056 (252)	1871 (273)	(+) 9.9
Caffeine	317.46	3737 (439)	2741 (343)	(+) 36.3
Caffeine	17,900.00	663 (77)	3093 (401)	(-) 78.6
Propranolol	396.83	202 (63)	1233 (235)	(-) 83.6
Propranolol	40.40	1501 (318)	4191 (679)	(-) 64.2

* Value are counts per minute (cpm).

† Data normalized to 1.0 × 10⁹ motile sperm/ml.

‡ All test values significantly different from controls (*p* < 0.05).

humans since 1973 (14). The goal of the therapist is to maximize drug benefits, and since intimate knowledge of biodistribution is important for many reasons (minimize toxicity, evaluate site penetration and biotransformation), optimization of therapy requires information unique to each patient at a specific stage of the disease. Manaka and Wolf (15) stated that the goal of radiopharmacokinetics is the characterization and control of drug kinetics as much as is practical with the view toward maximizing benefits and minimizing adverse effects. The complexity of these interactions is such, however, that it is possible to characterize only a part of drug behavior. For example, between individuals there are large variations in hepatic biotransformation of drugs. Baker et al. (16) lists genetics,

environmental conditions, nutrition, drugs, and disease as predisposing factors. In classical pharmacokinetics, the goal is to approximate the biological system, with consideration given to a series of discrete compartments, and then to focus on the rate at which the drug enters and exits them and the rate at which it undergoes chemical change. As a practical matter, however, it has been difficult to closely approximate actual conditions because of technical difficulties associated with the preparation of true tracers.

To consider how facets that have been discussed have had an impact on NM, we may consider how pharmacokinetic methods have been and are now being utilized clinically. For the most part, these have been limited to guid-

ing arterial infusion of chemotherapeutic agents in cancer (17), the development of kinetic (time-related compartmental distribution) models (15), and the likelihood that radiotracer forms of drugs may be used to evaluate target penetration and host resistance phenomena. The purposes of such methods are to assess:

1. the presence of collateral circulation around the target area,
2. collateral circulatory changes that may occur over a specific time frame,
3. the patency of vascular distribution into a particular area and how this changes with time,
4. the extent of arteriovenous shunting in this area,
5. whether there has been movement of the catheter tip during a course of intraarterial therapy,
6. the potential of adjuvants (such as starch microspheres) to optimize treatment effects,
7. the extraction fraction of a compound in an organ or tissue of interest and how this changes during disease,
8. the rate and extent of biotransformation within a particular organ or region.

As a recent promising approach to the individualization of drug dosages, Bayesian forecasting (18) offers an example of the type of information obtainable with use of radiolabeled drugs. Applied to drug therapy, Bayesian forecasting involves techniques whose essence is the use of both kinetic data from the patient about to undergo drug therapy and data available from other patients. The data obtained from these sources is fit to an equation containing two terms that represent these variables. The goal is to use the equation to more appropriately individualize drug dosage. The method holds promise in dealing with arbitrary dosage and sampling patterns. Its utility, however, could be extended to those patients about to be placed on therapy on whom there are no data available (which frequently occurs). In such patients, a radioactive analog of the drug could be used to provide data about the fraction of the administered dose extracted by a specific organ or tissue and to show how changes in this value may be monitored during the course of therapy.

The usual objections, based on organ and whole-body radiation, should be minimal for patients whose risk-benefit ratio is considered acceptable.

Other examples of the use of radionuclides to explore pharmacodynamics may be cited. Of special importance today is the potential use of drugs labeled with short half-lived positron emitters. In institutions in which there are production facilities, tests of predictive value might be performed when a determination must be made about whether or not there is an adequate drug concentration at the desired site. Also of importance is the use of radiopharmacokinetics for enhancing the emerging area of chronopharmacology (19).

RESEARCH AND SCIENTIFIC BASIS OF NUCLEAR MEDICINE MONITORING

NM physicians frequently are presented with opportunities to participate in research and to develop research skills. They may collaborate in the design and interpretation of investigational studies, such as clinical trials of new drugs and diagnostic tests. These must be carefully planned and executed to ensure that only accurate, reproducible information is added to the pool of medical knowledge.

Kerlinger (20) characterizes the scientific approach as, "a special systematized form of all reflective thinking and inquiry." He characterizes the scientific method as including the following process:

1. Problem-obstacle-idea—the clinician or investigator experiences a vague unrest about observed and unobserved phenomena. His or her objective then is to express the idea in a clear and manageable form.
2. Hypothesis—formulation of a conjectural statement or proposition about the relation between two or more phenomena or variables. The clinician may say, "If patient A continues on total parenteral nutrition (TPN), there may result bone disease that will be monitorable at an early stage with use of NM techniques."
3. Reasoning-deduction—deducing the consequences of the hypothesis. Deductive reasoning was added to the scientific method in

Table 9.2.

Compilation of Current NM Monitoring Capabilities*

Primarily Disease-related	Reference
Brain blood flow	46
Gastric emptying	
Adults	36
Children	51
GI bleeding	35
Heart	
Infarct size reduction	37
Ischemic versus infarcted myocardium	39
Functional capacity with use of dipyridamole	52
Intermediary metabolism	2
Lcgg-Calvé-Perthes disease	38
Liver function	16
Pulmonary embolism	42, 43
Primarily Drug Therapy-related	Reference
Antibiotic treatment in osteomyelitis	55
Asthma therapy, with function response measured	54
Chemotherapy, drug perfusion in	17
Chemotherapy, response to	39
Coronary vasodilation, dipyridamole use in	47
Drug-induced pulmonary disease	40, 41
Insulin antibodies, assessment before insulin dosing	48
Methacholine inhalation, bronchiolar response to	44
Primarily Surgical Therapy-related	Reference
Breast cancer treatment prognosis, internal mammary lymph node scintigraphy	49, 50
Nephroureteral dilatation with use of furosemide	56
Portal-systemic shunt, degree of after sclerosing therapy	45
Pulmonary osteoarthropathy, surgical treatment	53

* For a review of pre-1982 publications, see Reference 5.

the seventeenth century (21). Without it, certain behavioral research problems, such as testing the interactive effect of TPN, bone disease, and changes in radioactive count rates, would be insoluble.

4. Observation-test-experiment—an investigation of the validity of the relation expressed by the hypothesis. Hypotheses are not tested in reality; their deduced implications are.

The clinician then has the challenge of further developing the NM knowledge base. Although all NM physicians do not have the resources or opportunity to participate in scientific research, they can make a valid contribution by bringing to the fore the problems that they encounter in their practices. They may also be involved with research activities in collaboration with other health care practitioners.

Much could be said about the importance of precisely defined a priori research questions and hypotheses in the design, data collection, and interpretive stages of new NM monitoring methods. Three characteristics that distinguish good hypotheses are: (a) they are declarative sentences that express a relationship between two or more variables, (b) they have clear implications for testing, and (c) the variable must be measurable (22). With regard to our TPN illustration, the following statement illustrates these points:

"Nuclear medicine may be used to monitor the progression of bone disease in patients undergoing long-term TPN." This hypothesis is declarative and expresses a relationship between variables. The variables can be measured. The minimum criteria for a good hypothesis have, therefore, been met. The power of hypotheses lies in the possible generalized statements made about the meaning of data that has been collected during the course of a particular experiment.

As important as a useful hypothesis is, a valid research design or plan of study controls the investigation of the hypothesis. A good research design establishes good comparisons of the effect of an independent variable and reduces the number of competing explanations for an observed result. Several research designs are applicable for NM monitoring (23).

1. Static stimulus designs (SSD). All units or members of the selected patient population are exposed to the same manipulation (therapy), so-called one-shot studies. Monitoring is performed once before and once after the manipulation.
2. Nonstatic stimulus designs. Some units or members of the selected patient population are exposed to a zero amount of a manipulation (therapy); the balance are exposed to a non-zero amount of the manipulation. Monitoring is performed as in SSD. This is the most frequently used design in NM.
3. Mixed designs. These consist of some combination of the designs discussed previously.
4. Serial designs. Patients are exposed to manipulations (therapies) as described previously. Monitoring is performed, however, more than once before and/or after exposure to the manipulation. This type includes the so-called crossover design.

The most appropriate choice of a NM research design will result from knowledge of the possible extraneous sources of variation that may occur during data collection (measurement).

The scope of measurement includes the assignment of numbers to objects or events according to rules (24). For NM monitoring, this definition makes sense because in every case events (counts) are measured. In reality, however, NM measures events that are only indicators of the characteristics of events, i.e., labels or symbols. For example, Spielberg et al. (25) reported the assessment of toxicity to human lymphocytes and of changes in organ distribution as a result of increasing plasma concentrations of two analgesics. These authors developed an observable response (changes in counts) to the underlying unobservable and directly unmeasurable viability of the lymphocytes. The measurement focused on the relationship between the observable response and the underlying concept. The stronger the relationship, the more useful the possible inferences. Therefore, there must be due concern with the measurement process and its relation to the concept being tested. Similar cautions about the need to verify the reliability and validity of measurements taken as part of a NM monitoring

design may be cited. In this regard, reliability and validity are matters of degree for which exactness is an unachievable goal.

When the proposed NM study is one of a battery of tests for a particular process, with what weight should it contribute to a positive prognosis, a negative prognosis, or a requirement for further testing? That is, what is the prognostic effectiveness of the proposed study? Sequential data analysis may be employed in order to permit early termination of the study if the new method quickly proves to be superior or inferior. In these cases, criteria must be established before the study is begun such that it may be terminated at the point when, with the pre-assigned level of confidence (say 95%), there is a significant difference in efficacy between the two studies as measured by χ^2 . It should be emphasized that the investigator may either be the one performing the research project or the one assessing it, as it appears in a journal article. In either case, what remains is the accumulation, tabulation, categorization, review, and analysis (interpretation) of the data. Each of these processes has its associated mathematical concepts and methods of measurement, most of which are beyond the scope of this chapter. A recent review of these subjects which is pertinent for NM purposes has appeared (26).

As the foregoing discussion implies, the many facets that define the appropriateness of new NM studies should be dealt with on more than one level. It is one thing for a clinician to justify to various committees the proposed use of a new NM study on the basis that there is a clear need for it and that statistically it stands in a favorable light when it is compared with present methods. Other factors should be taken into account, however, so that more fundamental committee concerns will not delay the study's inauguration. These are listed in Table 9.3 and should be considered before human use committee authorization (26) is sought.

When the basic design and method of execution of a new NM monitoring project have been dealt with and there has been appropriate consideration given to the utility of the study from all possible perspectives, the most difficult parts of developing and executing the research protocol are behind the investigator.

Table 9.3.

NM Monitoring Checklist for Human Experimentation Committees

Evaluate the need for the proposed study.
Evaluate the efficacy of the proposed study (statistics).
Consider the appropriateness of the reference population and the relation between the technical sensitivity and specificity of the test. Consider also the "noise levels," i.e., the false positives and false negatives.
Evaluate the testing value. How effectively will the new test justify its cost in relation to established tests?
Joint probability, i.e., expected proportion of correctly diagnosed subjects (true positives and true negatives).
Cost values, i.e., retesting cost versus the risk of treating a nondiseased subject; cost associated with the risk of depriving a diseased subject of treatment; cost of the time delay associated with performing a test and reporting its result; and cost associated with a test that is too sensitive.
Design optimal test strategy (experimental design).

The final phase in the process is the preparation of a report to disseminate the data to others. A good report will successfully address the facets of (a) organizing thoughts logically and (b) expressing thoughts clearly. As a practical matter, it often is most difficult to deal properly with the organization of the report. In this case, clear concise advice to authors may be found in the *Council of Biology Editors (CBE) Style Manual* (27), which is used as a stylebook by many biomedical journals. Further information about writing final reports, as well as a checklist may be found in Zellmer (28).

COST EFFECTIVENESS OF NUCLEAR MEDICINE MONITORING

Medical care is different from other goods and services. The deep historic commitment to health care worldwide is reflected in institutional arrangements that have encouraged its growth and development. These include income tax deductions for medical expenses and insurance premiums and government financing of health care for the poor and elderly. Broadly speaking the differences can be grouped under the following headings (modified from Ref. 29):

1. social concern attached to the need for services;
2. position of providers as determiners of the level of patient care;
3. modified profit-seeking behavior of providers;
4. risks associated with random occurrence of illness;
5. lack of knowledge on the part of consumers about the services;
6. free-market modifying effects of provider licensure.

These differences help to explain the unique organization of the medical care industry with its associated governmental and nongovernmental restrictions and the fact that health care has come to represent a heavy financial burden for the private sector. The uniqueness in health care thus encompasses all levels of planning from federal expenditures to bedside decisions. A focus on bedside costs is the subject of this section.

It is noteworthy that there is more at stake than the new procedure's immediate cost. Its cost must be considered as part of a continuum of services designed for each case, since the results of any procedure and its perceived efficacy affects the course of diagnosis and treatment. The results of a well-established, appropriately timed and performed monitoring study may convince the clinician about the patient's condition. No other tests may be needed. As laboratory service costs increase, it becomes imperative to ensure wise spending of the health care dollar. The paramount expense is the cost of tests. What makes a good test? Most often there is a trade-off between operational properties (ease, speed, cost) and conceptual characteristics (reliability, validity, effectiveness, and value). A select few tests are best by both criteria.

For any new NM monitoring study, the elements of cost and their associated frequencies are (a) the cost of retesting or the risk of treating a nondiseased subject (false positive), (b) the cost associated with depriving a diseased subject of treatment (false negative), (c) the cost caused by the time delay associated with performing a test and reporting its results, and (d) the cost associated with the radiation dose.

These values may be expressed as shown in Table 9.4 (30).

The five outcomes, F , N , L , D , and X , are assumed to be mutually exclusive categories of the test result. The value, V , of the test may be represented as

$$V = D + X + P_F(1 - R)F + P_N(R)N + P_L L \quad \text{Equation 9.1}$$

The quadratic equation

$$P_N = A + BP_F + CP_F^2 \quad \text{Equation 9.2}$$

may be used to approximate the relation between P_N and P_F . The test is optimized when

$$P_F = \frac{B - F(1 - R)}{2C} \quad \text{Equation 9.3}$$

Implementation of the test selection method is accomplished by performing the following steps:

1. Estimate D , F , N , L , and X .
2. Estimate R .
3. Set the desired technical sensitivity and specificity trade-off as shown in Equation 9.2.
4. Determine the optimum P_F from Equation 9.3.
5. Compute P_N from the optimum P_F (use Equation 9.2).
6. Estimate P_L .

Table 9.4.

Elements of Cost in NM and Their Associated Frequencies (Adapted from M. Werner et al.: Strategy for cost-effective laboratory testing. *Hum. Pathol.* 4:17-30, 1973)

Cost Factor	Cost*	Frequency
Doing the test	D	1.00
Radiation dose	X	1.00
False positive	F	$P_F(1 - R)$
False negative	N	$P_N(R)$
Late result	L	P_L

* Abbreviations: R = prevalence of the disease or proportion of diseased patients; X = patient, operating personnel, and fetal dose; P_F = probability with which the test ascribes the disease to a disease-free person; P_N = probability with which the disease is not ascribed to diseased patients; P_L = frequency with which the test result takes too long; $1 - R$ = proportion of disease-free patients in the presenting population.

7. For each candidate test, substitute these values into Equation 9.1 to compute the cost of the test. The test of choice will be that which gives the minimum total cost.

One difficulty with this sequence lies in the fact that there is an absence of weighing of the terms in Equation 9.1 for such things as human suffering, societal burdens, and the recent advent of home health care and hospice services which have made home recuperation an appealing alternative to prolonged hospitalization. One strength of the sequence is that health care providers are encouraged to be more alert to discovering adverse effects of therapy early in the NM monitoring sequence. There would thus result in a reduced incidence of complications and more timely hospital release.

In conclusion, this discussion has several implications for health care economics in general and for NM monitoring in particular:

1. Strategic planning is more important now for clinicians. From the present cost-containment climate (for a review of 1983 Medicare legislation, see the *Federal Register*, September 1, 1983, p. 39746ff), more aggressive economic competition for new tests will likely emerge.
2. Directors and managers will keep closer tabs on operational expenses.
3. Clinicians will have to develop their political skills.

Consideration of economic factors will help maintain NM at the forefront of monitoring services in medicine (see Table 9.5).

EFFICACY OF NM MONITORING COMPARED WITH OTHER METHODS

The advent of the concept of monitoring, its subsequent acceptance, and its influence on pharmacology can be attributed to radioisotope methodology. Earlier in this chapter, we discussed the use of pharmacodynamic tracers. Studies correlating serum drug concentration with therapeutic effect were initially performed with use of ultraviolet (UV) spectrophotometry and, later, with gas-liquid chromatography (GLC). The requirement for large samples for use of UV spectrophotometry and the complexity of GLC equipment tempered advances in this

Table 9.5.

Economic Factors to Be Considered When Any New NM Diagnostic Procedure Is Implemented*

- Personnel training requirements: How extensive are they?
- Protocol formulation: Should protocol be designed to maximize test utility?
- Projected frequency of use of the test: Will the frequency justify developmental costs, or is the test to be viewed as an "orphan"?
- Maintenance costs of the procedure: What are the projected costs of quality control measures designed to maintain efficacy?
- Patient safety during the test: Will test performance jeopardize care that the patient would otherwise receive in an emergency situation?
- What will be replaced by this study? The question, "How will this test complement others," may no longer be appropriate.
- Patient cooperation: Can the test be successfully performed with minimal patient cooperation?
- Goal definition.
- Likelihood of future third party payment.
- Appropriateness of the setting: Inpatient or outpatient? In the future, outpatient settings may be most appropriate for instituting new tests.

* If the answers to two or more of these factors reflect poorly on the proposed test, there may be difficulty in justifying its use.

area. Radioimmunoassay permitted quantitation in microvolumes of serum. The complexity of the methodology, however, has limited its widespread application.

When there are choices for monitoring disease or the results of therapy, there arises a need to compare modalities. The ability to select the most appropriate monitoring tool from the available armamentarium can thus be preserved. When, for instance, information about hepatic blood flow is required, an indicator infusion and extraction technique should be considered (31). Drugs with high first-pass extraction may be used when information about portal systemic blood flow is desired. Finally, radioisotope breath tests provide useful information about the metabolic capacity of the liver. The need for appropriate selection criteria among such closely related modalities may not be satisfiable when political or economic factors interfere or when there is a strong bias in favor of one technique.

If such obstacles can be overcome, what favorable factors should NM possess in order that serious consideration will be given to starting clinical trials?

Preclinical Testing with Appropriate Models

The elimination of difficult-to-control variables will serve to satisfy the expectation that results can accurately predict the success or failure of later clinical trials. The efficacy of a NM study and the way in which clinicians view test results may depend on the adequacy of the model used during preclinical trials. In most cases, model selection presents serious problems because of questions raised about relevance. For example, a suggestion to use normal human plasma at 37°C as a suspending medium when the stability of a radiopharmaceutical is being tested would evoke minimal criticism. However, testing the efficacy of a model for inflammation is more likely to draw criticism no matter which of the available models is chosen. The difficulty arises because of the need to identify the relative contribution of nonspecific uptake due to increased blood flow. Of the available choices, early chronic osteomyelitis seems most appropriate, since blood flow complications are largely eliminated.

There will be even more difficulty on both scientific and moral grounds, however, when the clinician is faced with the need to determine to what extent a new chemical or a series of its homologs is effective in monitoring the progression of necrotic tissue in patients admitted to the emergency room as a result of electrical injury. Symposia that address the challenges associated with this aspect of NM monitoring have been convened (Society of Nuclear Medicine Annual Meeting, 1982) and a publication which addresses this topic recently appeared (31a). It is a focus of our attention and a subject of importance in other areas of our society. In the milieu of present ethical constraints, properly modeled preclinical trials will promote authorization for human use, while those which are faulty will be set aside. (See also Chapter 22.)

Low Radiation Doses

The question of radiation risk invariably arises when the use of radioisotopes is proposed as part of a new monitoring device. The uncer-

tainty stems from a lack of reliable information. For instance, it is not known whether doses of γ - or x-rays of 100 mrad/yr are detrimental to man the whole organism (32), since there are many factors that have made risk determination for low-dose, low linear energy transfer (LET) radiation difficult. These include uncertainty about the shape of the dose-response curve for cancer induction, the effect of age, the masking effects of the environment, and the genotypic effect on susceptibility to injury. The risk of genetic effects from low-dose, low LET radiation have also been difficult to measure. It is estimated from animal data that 1 rem of partial exposure throughout the general population will result in the first generation in an increase of 5–75 additional serious genetic disorders/million liveborn offspring. Radiation-induced transmitted genetic effects, however, have not been demonstrated in humans, and it is not expected that useful information will soon be forthcoming.

The question of leukocyte damage resulting from NM studies has been addressed (33). It can be concluded from the reports that ^{111}In -oxine may cause aberrations in tissue distribution when these leukocytes are compared with non-radiolabeled leukocytes. The clinical importance of these cellular effects, however, has not been placed in perspective against the rapidly increasing use of ^{111}In in cell-labeling procedures. The problem will not go away when, in the near future, cells can be labeled *in vivo* by specifically targeted radionuclides, since the effects on cell function are believed to be caused mostly by the radioactivity, not so much by the cell isolation procedures (34).

Absent from these studies are data that would relate the cellular effects of radiation to short- and long-term effects on organs and individuals. What should be remembered is the notion that some tissue damage probably occurs during the course of these studies. So long as whole-body and critical organ doses remain below the risk-benefit threshold, any proposed NM monitoring study should be acceptable for human use.

Radiopharmaceutical Efficacy

Much has already been written in this volume about radiopharmaceutical efficacy. The inter-

ested reader is referred to chapters dealing more specifically with radiopharmaceutical quality and its effect on imaging and laboratory procedures. The reader should be reminded, however, of the absolute importance of using documented high-quality radiopharmaceuticals in the most appropriate setting during the preclinical and clinical stages of evaluation of a new NM procedure for monitoring.

Probably nowhere has the importance of high-quality, freshly prepared radiopharmaceuticals been as effectively demonstrated as in the use of $^{99\text{m}}\text{Tc}$ -labeled sulfur colloid and $^{99\text{m}}\text{Tc}$ -labeled RBC for monitoring the results of surgical and pharmacologic treatment of GI bleeding, especially of the lower GI tract (35). In those studies, since bleeding may be transient and the rate of blood loss may be low (less than 1 ml/min), an adequate contrast between the bleeding site and the background is essential. The relationship between uptake of radioactivity at the bleeding site and decrease in background radioactivity with elapsed time can be described by use of the following rate constant:

$$C \propto \frac{dN_A/dt}{dN_B/dt} \cdot t \quad \text{Equation 9.4}$$

where dN_A/dt and dN_B/dt represent the rate of change of radioactivity at the bleeding site and in the blood background, respectively. Therefore, the absolute contrast, C , is a function of these rates multiplied by the elapsed time after injection of the radiopharmaceutical. The rates may be closely approximated in an animal model by counting the radioactivity in each area over some period of time.

This information makes it possible to demonstrate the usefulness of a radiopharmaceutical that has minimal amount of radiochemical contamination. In the case of $^{99\text{m}}\text{Tc}$ -labeled sulfur colloid, since a normal liver removes radiocolloid from the blood at a rate approximately equal to the denominator in Equation 9.4, and since insignificant amounts of unreacted $^{99\text{m}}\text{Tc}$ from the radiopharmaceutical will be removed from the blood during the first 10 minutes after injection, it is possible to predict the difference in effectiveness between a radiopharmaceutical with 1% free pertechnetate and one containing 3% free pertechnetate. It is necessary only to make the assumption that the rates of uptake

into the target and decrease of radioactivity from background are described by first-order kinetics and then to change Equation 9.4 to the more familiar form,

$$C = \frac{N_A^{\lambda t}}{N_B^{\lambda t}} \quad \text{Equation 9.5}$$

Since $t_B = 4$ minutes (approximate half-time for liver extraction of blood radioactivity), and since t_A depends on the volume of blood being lost at the bleeding site and so may be disregarded here at 10 minutes, it can be seen that there will be $3^{1.73/11.73}$ or 7 times as much background radioactivity at 10 minutes when the preparation containing 3% radiochemical impurity is used. Furthermore, because of the asymptotic nature of the line describing the decrease in background radioactivity, it may never be possible to achieve a comparably low background radioactivity with the 3% product. Some may observe that if there is substantial bleeding at the site of the defect, the rate of disappearance of background becomes insignificant. Such an argument, however, disregards one strength of this procedure—the ability to detect changes in slow but significant GI bleeding and to monitor the results of therapy over long periods of time with use of a minimally invasive procedure.

Other examples of the importance of optimizing the characteristics of the radiopharmaceutical could be included here. Baker et al. (16) has, for instance, provided a list of 12 characteristics possessed by an ideal breath test substrate for measurement of hepatic function (see Table 9.6). Of these characteristics, adequate quality control of the substrate (the radiopharmaceutical) is essential. If even a small fraction of the substrate is a radiochemical contaminant, extrahepatic metabolism may occur, which renders the test useless as a measure of liver function.

PITFALLS AND PROBLEMS IN NM MONITORING

Even if it were possible to limit one's practice to a single entity, such as the state of renal function after renal transplant surgery, effective monitoring would be a difficult task for NM. These difficulties arise because it is not possible to effectively characterize patients into broad

Table 9.6.

Characteristics of an Ideal Breath Test Substrate for Measurement of Hepatic Function (Adapted from A. Baker et al.: Clinical utility of breath tests for hepatic function assessment. *Semin. Liver Dis.* 3:318-329, 1983)

Cleavage of the label is the rate-limiting, directly measurable step
Liver metabolism only
Little or no pharmacologic effect by the substrate
Rapid metabolism
Rate of excretion appropriate to permit timely sampling ($^{14}\text{CO}_2$)
Negligible binding to plasma proteins
Safety (toxicity, radiation safety)
Infinite distribution in total body water
Low hepatic extraction efficiency
High water solubility
Absorption rapid and consistent

categories of disease and health. If one attempts to base a monitoring practice on the basis of disease diagnosis, difficulties quickly arise because of factors that may not have been considered relevant. A list of factors that can interfere with NM monitoring is included in Table 9.7.

The data in Table 9.7 imply that if monitoring in NM is to be effective, the clinician must pause before beginning the study to consider how each of the listed factors may affect his perception of the outcome. As an example, the effect of patient age on the results of a therapeutic procedure is shown in Figure 9.3. It is expected that not all patients will be in a position to undergo equally aggressive therapy. Individualization of both drug dosage and surgical intervention are routinely practiced in both medicine and surgery. This should be appreciated in NM also. Figure 9.3 might appear to be misleading because the important differences between youth and age are the kinetics of metabolic processes and organ function. Because these are to be considered normal variants, however, the validity of the figure becomes apparent, since disease is listed separately among the factors that can interfere with NM monitoring in Table 9.7.

A difficulty with some multiple NM monitoring procedures, in which all studies must be performed identically, involves information that is unintentionally omitted from journal articles

which may form the basis for study protocols. The omitted information is unknown to those who try to duplicate the reported technique, and therefore, lengthening of the time required for the study to come into clinical use may occur. The gastric emptying studies recently reported by Malmud et al. (36) are one example. Although the article remains an important contribution to the NM literature, there is no mention in it of the importance of patient movement during the study between periods of data accumulation. It would be reasonable to expect some clinicians to perform the entire study with the patient supine. Results in such cases could deviate greatly from reported literature values, and some reconsideration and reflection would be necessary before further trials to obtain acceptable data would be attempted. Difficulties such as these should be resolved by the publisher and the author before publication.

SUMMARY

The demands of present biomedical technology are not trivial. Such technology has placed unaccustomed demands on clinicians. NM has been no exception. A large number of new tests which have the potential for contributing to patient management in ways unknown until recently are available.

This chapter was designed to provide assistance in test assessment with the following temporal sequence: (a) What questions can these tests answer? (b) Which test appears to be most appropriate for the question at hand? (c) Is

Table 9.7.

Factors That Can Interfere with the Proper Performance of NM Monitoring Studies

Age
Sex
Abnormal metabolic and physiologic variants
Incompletely written journal articles
Concurrent food and drug intake
Lack of appropriateness of what is being monitored
Difficulty in obtaining information
Statistical difficulty
Absence of quantifiable variables among subjects
Inadequate communication with physicians and patient
Presence of disease

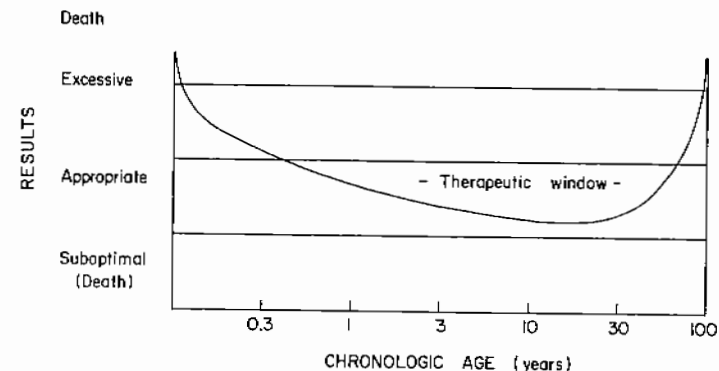

Figure 9.3. Result of a given therapeutic procedure for a serious disease on subjects of increasing age. The curved line represents the expected effect over a range of patient ages.

the selected test cost effective? (d) Does the selected test stand on solid experiential and/or factual ground? (e) How can the data obtained best be handled?

The widespread acceptance of these monitoring tests indicates that the available rewards are greater than the demands placed on us in using them. Judiciously used, these tests should continue to be important for both the provider and the recipient of health care.

ACKNOWLEDGMENTS

The author is grateful to Stephen E. Long, M.D., Baylor College of Medicine, St. Luke's Episcopal Hospital, Houston, TX, for review and technical assistance and to Linda Watts for manuscript preparation.

REFERENCES

1. Del Guercio L: *Principles of Surgery*. New York, McGraw-Hill, 1979, p 533.
2. Bircher J: Quantitative assessment of deranged hepatic function: a missed opportunity? *Semin Liver Dis* 3:275-284, 1983.
3. Pippinger C: Therapeutic drug monitoring: an overview. *Therap Drug Monit* 1:3-9, 1979.
4. Mason J: *Law and Medical Ethics*. London, Butterworths, 1983, p 129.
5. Hladik W, Nigg K, Rhodes B: Drug-induced changes in the biologic distribution of radiopharmaceuticals. *Semin Nucl Med* 12:184-218, 1982.
6. Froelich J, Juni J: Glucagon in the scintigraphic diagnosis of small bowel hemorrhage by Tc-99m labeled red blood cells. *Radiology* 151:239-242, 1984.
7. Sisson J: Applying the radioactive eraser I-131 to ablate normal thyroid tissue in patients from whom thyroid CA has been resected. *J Nucl Med* 24:743-745, 1983.
8. Ganatra R, Buddemeyer E, Deadhar M, et al: Modification in biphasic liquid scintillation vial system for radiometry. *J Nucl Med* 21:480-483, 1980.
9. Zipper J, Wheeler R, Potts D, Rivera M: Propranolol as a novel, effective spermicide: preliminary findings. *Br Med J* 287:1245-1246, 1983.
10. Zipper J, Bruzzon M, Angelo S, et al: Effect of topically applied adrenergic blockers on fertility. *Int J Fertil* 27:242-245, 1982.
11. Gobuty A, Cameron W: Non-destructive radioassay of sperm viability (abstract). *J Nucl Med* 19:722, 1978.
12. Ruzevich M: A radiometric method of evaluating the effects of isoproterenol, propranolol and caffeine on sperm metabolism. Masters Thesis, University of Kansas, 1981.
13. Toth-Allen J: Radiopharmacokinetic studies in mice. Doctorate Thesis, Michigan State University, 1970.
14. De Conti R, Toftness B, Lange R, Creasey W: Clinical and pharmacological studies with cis-diaminedichloroplatinum (II). *Cancer Res* 33:1310-1315, 1973.
15. Manaka R, Wolf W: Cisplatin: *Current Status and New Developments*. New York, Academic Press, 1980, pp 271-283.
16. Baker A, Kotake A, Schoeller D: Clinical utility of breath tests for hepatic function assessment. *Semin Liver Dis* 3:318-329, 1983.
17. Bledin A, Kim E, Haynie T: Technetium-99m macroaggregated albumin angiography and perfusion. *JAMA* 250:941-943, 1983.
18. Sheiner L, Beal S, Rosenberg B, Marathe V: Forecasting individual pharmacokinetics. *Clin Pharmacol Ther* 26:294-305, 1979.
19. Halberg F, Kabat H, Klein P: Chronopharmacology: a therapeutic frontier. *Am J Hosp Pharm* 37:101-106, 1980.
20. Kerlinger F: *Foundations of Behavioral Research*, ed

2. New York, Holt, Reinhart and Winston, 1973, pp 11-15.
21. Conant J: *Science and Common Sense*. New Haven, Yale University Press, 1951, pp 32-33.
22. Nelson A Jr: Developing a research hypothesis. *Am J Hosp Pharm* 37:264-265, 1980.
23. Mikeal R: Research design: general designs. *Am J Hosp Pharm*. 37:541-548, 1980.
24. Stevens S: *Handbook of Experimental Psychology*. New York, John Wiley & Sons, 1951, p 22.
25. Spielberg S, Gordon G, Blake D: Predisposition to phenytoin hepatotoxicity assessed in vitro. *N Engl J Med* 305:722-727, 1981.
26. O'Brien P, Shampo M, Robertson J: Statistics for nuclear medicine. *J Nucl Med* 24:83-88, 1983
27. Council of Biology Editors: *Council of Biology Editors Style Manual*, ed 4. Arlington, VA, American Institute of Biological Sciences, 1978.
28. Zellmer W: How to write a research report for publication. *Am J Hosp Pharm* 38:545-550, 1981
29. Pauley M: *Issues in Health Economics*. Rockville, MD, Aspen Publishing, 1982, pp 3-24.
30. Werner M, Brooks S, Wette R: Strategy for cost-effective laboratory testing. *Hum Pathol* 4:17-30, 1973.
31. Bradley S: *Handbook of Physiology*, Circulation II. Washington DC, American Physiological Society, 1963, pp 1387-1438.
- 31a. Lambrecht R, Eckelman W: *Animal Models in Radio-tracer Design*. New York, Springer-Verlag, 1983.
32. Handler P: *The Effects on Populations of Exposure to Low Levels of Ionizing Radiation (BEIR)*. Washington DC, National Academy Press, 1980, p 3.
33. Watson E: Cell labeling: radiation dose and effects. *J Nucl Med* 24:637-640, 1983.
34. McAfee J, Subramanian G, Gagne G: Technique of Leukocyte harvesting and labeling: problems and perspectives. *Semin Nucl Med* 14:83-106, 1984.
35. Alavi A: Detection of gastrointestinal bleeding with ^{99m}Tc-sulfur colloid. *Semin Nuc Med* 12:126-138, 1982.
36. Malmud L, Fisher R, Knight L, Rock E: Scintigraphic evaluation of gastric emptying. *Semin Nucl Med* 12:116-125, 1982.
37. Marshall J, Tillisch J, Phelps M, et al: Identification and differentiation of resting myocardial ischemia and infarction in man with positron computed tomography, ¹⁸F-deoxyglucose and N-13 ammonia. *Circulation* 67:766-788, 1983.
38. Conway J, Weiss S, Maldonado V: Scintigraphic patterns in Legg-Calve-Perthes disease. *Radiology* 149(P):102, 1983.
39. Yeh S, Rosen G, Caparros B, Benua R: Semiquantitative gallium scintigraphy in patients with osteogenic sarcoma. *Clin Nucl Med* 4:175-183, 1984.
40. Balikian J, Jochelson M, Bauer K, et al: Pulmonary complications of chemotherapy regimens containing bleomycin. *AJR* 139:455-461, 1982.
41. Ohiner H, Schwartz A, Rubio F, Dameshek W: Interstitial pulmonary fibrosis following busulfan therapy. *Am J Med* 31:134-139, 1961.
42. Dalen J, Alpert J: Natural history of pulmonary embolism. *Prog Cardiovasc Dis* 17:259-270, 1975.
43. McNeil B: A diagnostic strategy using ventilation-perfusion studies in patients suspect for pulmonary embolism. *J Nucl Med* 17:613-616, 1976.
44. Byrom E, Chausow A, Ryo U, et al: Quantification of Kr-81m ventilation image response to methacholine. *J Nucl Med* 25:p88, 1984.
45. Tonami N, Nakajima K, Watanabe N, et al: Post-therapeutic change in portal-systemic circulation investigated by Tl-201 per rectal administration. *J Nucl Med* 25:p97, 1984.
46. Raichle M, Martin W, Herscovitch P, et al: Brain blood flow measured with intravenous H₂ ¹⁵O. Implementation and validation. *J Nucl Med* 24:790-798, 1983.
47. Gould K, Wescott R, Albro P, Hamilton G: Non-invasive assessment of coronary stenosis by myocardial imaging during pharmacologic coronary vasodilation. Clinical methodology and feasibility. *Am J Cardiol* 41:279-287, 1978.
48. Palmer J, Asplin C, Clemons P, et al: Insulin antibodies in insulin-dependent diabetics before insulin treatment. *Science* 222:1337-1339, 1983.
49. Collier B, Palmer D, Wilson J, et al: Internal mammary lymphoscintigraphy in patients with breast cancer. *Radiology* 147:845-848, 1983.
50. Ege G, Elhakim T: The relevance of internal mammary lymphoscintigraphy in the management of breast carcinoma. *Clin Oncol* 10:3, 1984.
51. Rosen R, Hall W: Analysis of gastric emptying studies in a pediatric population. *J Nucl Med* 24:p33, 1983.
52. Kowey P, Friedman P, Podrid P, et al: Use of radionuclide ventriculography for assessment of changes in myocardial performance induced by disopyramide phosphate. *Am Heart J* 104:769-774, 1982.
53. Lopez-Majano J, Britt T: Pulmonary hypertrophic osteoarthropathy: its modification and therapy. *Eur J Nucl Med* 7:419-421, 1982.
54. Chopra S, Taplin G, Tashkin D: Imaging sites of obstruction and measuring function response to therapy in asthma. *J Nucl Med* 18:606, 1977.
55. Graham G, Lundy M, Frederick R, et al: Predicting the cure of osteomyelitis under treatment. *J Nucl Med* 24:110-113, 1983.
56. Koff S, Thrall J, Keyes J Jr: Assessment of hydro-ureteronephrosis in children using diuretic radionuclide urography. *J Urol* 123:531-534, 1980.

10

Interventional Studies in Nuclear Medicine

Gopal B. Saha, Dennis P. Swanson, and William B. Hladik III

Pharmacological interventions in nuclear medicine studies have been in practice for a long time. The triiodothyronine (T₃) suppression, thyroid-stimulating hormone (TSH) stimulation, and perchlorate discharge tests are common examples of well-established diagnostic interventional studies. In recent years, pharmacologic and physiologic interventions in other nuclear medicine procedures have drawn considerable attention (1-3).

The primary purpose of these interventions is to augment, complement or, more often, differentiate the information obtained from conventional nuclear medicine diagnostic studies. Pharmacologic interventions involve the administration of a specific drug before, during, or after the administration of radiopharmaceutical for a given study. The change in information due to intervention of the drug offers clues to differentiating various disease conditions. These changes can be brought about by physiologic interventions also, e.g., exercise in radionuclide ventriculography. In the latter interventions, the physiologic function of an organ is enhanced or decreased by physical maneuvers, and the changes observed can be used to differentiate various disease conditions.

THYROID**Triiodothyronine**

Triiodothyronine (T₃) is a hormone produced by the thyroid gland through iodination of tyrosine. It is bound within the stored thyroglobulin of the intrafollicular colloid. It is liberated by enzymatic proteolysis into blood circulation where it is bound specifically to proteins. The serum level of T₃ is governed by the TSH secreted by the pituitary gland, and an

excessive level can act on the pituitary gland to shut off the release of TSH which, in turn, diminishes the thyroid activity. The T₃ level in normal persons is 0.2-0.3 µg/100 ml of serum. It is, as would be expected, elevated in hyperthyroidism and depressed in hypothyroidism.

The first thyroid uptake test with use of sodium [¹³¹I]iodide was introduced by Hamilton and Soley (4-6) and provided significant information about the functional status of the thyroid gland in the production of thyroid hormones. Since many steps are involved in hormonal synthesis in the thyroid glands, soon after the introduction of the iodine uptake test for the thyroid, hormonal manipulation was employed to complement the normal iodine uptake test in order to delineate functional states of the thyroid gland.

The T₃ suppression test is one of several hormonal maneuvers that involves administration of T₃ in order to determine the autonomy of a functioning hot nodule or a diffusely enlarged gland. In this test, an initial 24-hour iodine uptake is obtained, followed by administration of 75-100 µg of T₃ in three divided doses daily for 7-10 days. The residual activity is determined on the eighth day, and then a repeat 24-hour uptake is obtained after correction for residual activity. In normal thyroid glands, the repeat 24-hour ¹³¹I uptake value falls to 50% of the presuppression value or lower. The administration of exogenous T₃ produces a negative feedback to the pituitary which, in turn, results in cessation of TSH production and release. This diminishes the thyroid function; hence there is less ¹³¹I uptake. Most, if not all, nontoxic goiters suppress normally. Failure of thyroid uptake to diminish by more than 50% indi-

states that the tissues are functioning autonomously but not under the influence of TSH (7, 8). Such autonomy is observed in patients with hyperthyroidism produced by diffuse hyperplasia (Graves' disease) or by a toxic nodule (Plummer's disease) or in patients with euthyroid autonomous nodule. It should be noted that since T_3 produces such side effects on the heart as arrhythmias and angina, the T_3 suppression test should be performed on cardiac patients with caution.

The T_3 suppression test has been largely replaced by thyrotropin-releasing hormone (TRH) infusion test. This test is relatively less time-consuming and requires no administration of radioactivity. The method involves administration of TRH and then assessment of TSH production in hyperthyroid patients. This procedure allows assessment of gland autonomy without the administration of T_3 to patients who may already be thyrotoxic (9).

Thyroid-stimulating Hormone

Thyroid-stimulating hormone (TSH) is produced by the pituitary gland and stimulates all of the thyroid enzymatic processes from iodide trapping to hormone secretion. Thus its effects on thyroid function can be evaluated at almost any level of exogenous administration. It is available as a lyophilized powder that is soluble in saline. It retains its potency in solution for at least 2 weeks if it is refrigerated.

The TSH stimulation test has been used to differentiate primary hypothyroidism from secondary hypothyroidism (10, 11). The test is performed by first obtaining a baseline 24-hour radioiodine uptake, followed immediately by intramuscular administration of 5–10 U of bovine TSH for 3 days. The radioiodine uptake is then repeated on the fourth day. Normally, the latter uptake value is more than 50% above the baseline. In secondary hypothyroidism, there is a defect in TSH production by the pituitary gland, and the thyroid gland responds to exogenous TSH. On the other hand, in primary hypothyroidism the defect is at the thyroid level, and the gland does not respond to either endogenous or exogenous TSH.

In practice, the TSH stimulation test is not very common. Bovine TSH may induce ana-

phylactic reactions (mostly allergic) in patients (12).

Potassium Perchlorate

The potassium perchlorate test is useful for identifying congenital or acquired organification defects in the thyroid gland. In diseases such as Hashimoto's thyroiditis, the thyroid gland may trap iodide but not organify it, because of an uncoupling of the trapping and organification mechanisms. In these patients, perchlorate, as an anion, successfully competes with iodide for the binding sites in the thyroid gland and displaces nonorganified iodide from the gland (13–15).

The potassium perchlorate test involves an initial oral administration of a tracer dose of ^{131}I and subsequent determination of a baseline iodine uptake at 2 hours. Then, at least 1 gm (600 mg for children) of potassium perchlorate is administered orally, and half-hourly iodine uptakes are measured for the next 2 hours. In normal patients, the iodine uptake after perchlorate administration is not altered. In patients with organification defects, however, the perchlorate displaces iodide from the thyroid gland, and the uptake value falls at least 10–15% below the 2-hour baseline value.

ADRENAL GLAND

Dexamethasone

Dexamethasone is a synthetic adrenocortical steroid that is used for therapy in adrenocortical deficiency states; it is also used as an anti-inflammatory agent. It is available in white, odorless, crystalline powder form and is insoluble in water. Dexamethasone is readily absorbed from the gastrointestinal tract.

Cholesterol is transported, esterified, and synthesized into various adrenocortical steroids and stored in the adrenal cortex whose function is governed by the anterior pituitary adrenocorticotrophic hormone, ACTH. Therefore, adrenal scanning has been successfully performed with use of 19- ^{131}I iodocholesterol (16, 17) and later with the superior agent, 6 β - ^{131}I iodomethyl-19-norcholesterol, NP-59 (18).

Hyperaldosteronism can be caused by both hyperplasia or adenoma of the adrenal gland. In order to differentiate between the two states, the

dexamethasone suppression technique is used (19, 20). Dexamethasone suppresses activity of the zona fasciculata by shutting off ACTH production, which thus facilitates evaluation of activity of the zona glomerulosa for aldosterone production (3). Normal adrenal uptake is totally suppressed for 5 or 6 days with dexamethasone.

In this test, 4 mg dexamethasone is administered daily for 2 days prior to injection of ^{131}I -NP-59 and is continued after injection until imaging is completed. Adrenal scintigraphs are obtained serially between 1 and 5 days following administration of NP-59 (19). In patients with aldosteronomas, earlier unilateral uptake normally is seen on the side of adenoma, with little or no activity noted in the contralateral gland (Fig. 10.1). On the other hand, patients with proven bilateral nodular hyperplasia have shown early uptake in both glands by 5 or 6 days after NP-59 administration (19–21).

CARDIOVASCULAR SYSTEM

Dipyridamole

Dipyridamole is a nonnitrate vasodilator available in yellow, crystal-like powder that is slightly soluble in water and very soluble in alcohol. It increases coronary blood flow primarily by a selective dilation of the coronary arteries, without significantly altering the systemic blood flow (22). It increases coronary sinus oxygen saturation without significantly changing myocardial oxygen consumption. It is mostly excreted via the bile into the feces. No specific contraindication has been reported. Its usual side effects are headache, dizziness, and weakness. Intravenous dipyridamole may decrease blood pressure and increase heart rate and cardiac output due to dilation of systemic resistance vessels. Dipyridamole may cause vasodilation by the hydrolysis of cyclic AMP by inhibition of the enzyme phosphodiesterase or

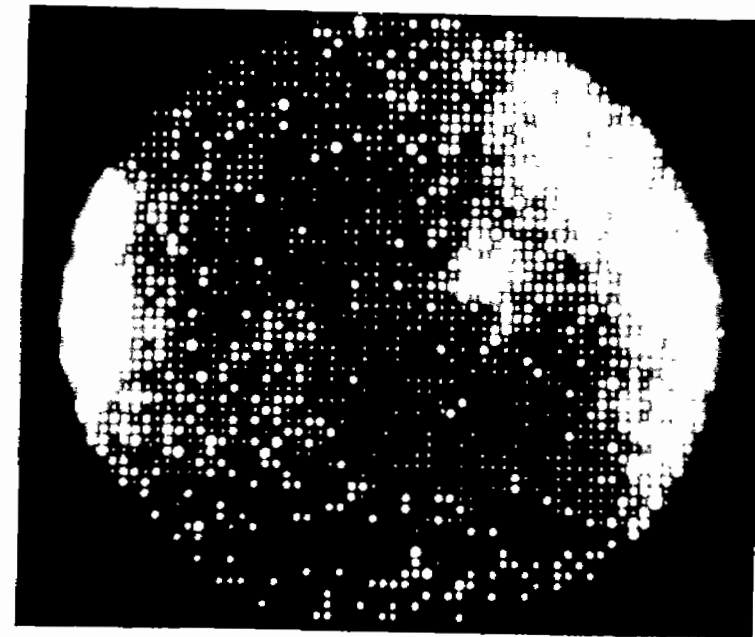

Figure 10.1. Abnormal dexamethasone suppression adrenal scintigram obtained 3 days after intravenous injection of NP-59 into a patient with hyperaldosteronism. Unilateral early breakthrough of adrenal visualization is indicative of adenoma.

by inhibition of adenosine deaminase in the blood, which thus allows accumulation of adenosine, a potent vasodilator (23).

Because of its vasodilating effects on coronary arteries, dipyridamole has been used in myocardial scintigraphy with ^{201}Tl to differentiate cardiac perfusion abnormalities from normal perfusion as an alternative to exercise stress. An example is illustrated in Figure 10.2. Hamilton et al. (24) studied the effects of dipyridamole (0.5 mg/kg intravenously) in normal dogs by use of myocardial scintigraphy with ^{201}Tl and

observed a 60% increase in ^{201}Tl concentration in the left ventricle. Gould et al. (25) compared the effect of dipyridamole with that of treadmill stress on scintigraphy with ^{201}Tl . At an intravenous dose of dipyridamole of 0.14 mg/kg/min, given 4 minutes prior to administration of ^{201}Tl , they observed images of superior or equal quality to stress images. Several studies on the topic have been carried out (24–30). Sklar et al. (26), Sochor et al. (27), and Schmoliner et al. (29) successfully detected coronary artery diseases by use of scintigraphy with ^{201}Tl after

vasodilation with dipyridamole. Demangeat et al. (28) and Josephson et al. (30) found intravenous dipyridamole to be a reliable alternative to exercise in ^{201}Tl studies for the accurate detection of coronary artery stenoses. All of these studies have shown that dipyridamole could replace exercise in the ^{201}Tl study, particularly in patients either at risk or having difficulty doing the exercise.

Nitroglycerin

Nitroglycerin or glyceryl nitrate acts as a potent vasodilator, particularly for coronary arteries, by reducing the cardiac workload. Its exact mechanism is not known, but it acts directly on smooth muscles. It is administered sublingually; its action starts 1–3 minutes after administration and lasts for 30–60 minutes. It is most commonly used for treating patients with angina pectoris. Side effects such as transient headache, weakness, and palpitation may result from its use.

Salel et al. (31) employed pharmacologic intervention with nitroglycerin in cardiac blood pool radionuclidic angiography to evaluate the viability of abnormally contracting ventricular segments in patients with clinical coronary disease. Responses of disordered wall motion and alterations in cardiac pump performance to sublingual nitroglycerin could differentiate dys-synergic areas of infarction and ischemia. Nitroglycerin produced significantly greater reductions in end-systolic volume in patients without infarction than in patients with previous infarction, which thereby results in a substantial increase in ejection fraction in the former rather than the latter group. Rosanski et al. (32) could make accurate scintigraphic differentiation of reversible and nonreversible asynergic areas of myocardium by gated blood pool study before and after pharmacologic intervention with nitroglycerin. In a study by Borer et al. (33), nitroglycerin improved qualitatively assessed regional asynergy in myocardium.

Physiologic Interventions

By far, the most prominent use of physiologic interventional studies in nuclear medicine has been in the area of cardiac imaging. Physiologic stress studies test the reserve capacity of both

the coronary blood flow and the myocardial function (34, 35). In other words, these tests determine how a patient's coronary vessels and cardiac function will respond to increases in oxygen demand. The underlying principle is that individuals with healthy myocardium and coronary vessels respond to physiologic stress with a significant increase in cardiac output and coronary blood flow, whereas patients with cardiac disease may not have the ability or "reserve" to do so. The advantage of performing these studies is that they provide additional diagnostic information, since at rest many patients with myocardial disease may show apparently normal cardiovascular radionuclide studies.

Dynamic stress studies are most commonly performed with use of either a treadmill or a bicycle ergometer in conjunction with either ^{201}Tl imaging or radionuclide angiocardiology. Areas of ischemia are most likely to be observed in ^{201}Tl studies when the individual is stressed, and these defects appear as photon-deficient areas on the resulting image. In radionuclide ventriculography, areas of wall motion abnormalities often become more striking at exercise. Global ejection fraction may fall in patients with coronary artery disease but typically will increase in normal patients (34).

Other forms of stress testing, such as isometric exercise (36), cold pressor testing (37), and atrial pacing (38), are available for nuclear cardiology. These tests have been reviewed in detail by Buda in a recent publication (34).

KIDNEYS

Furosemide

Furosemide, a sulfonamide derivative, is a high-ceiling diuretic that exerts its action by inhibiting the reabsorption of sodium and chloride ions from the ascending loop of Henle and the distal renal tubules. Furosemide also inhibits the reabsorption and promotes the excretion of potassium ion. The peak diuresis obtained with furosemide is greater than that observed for other diuretics (i.e., thiazides) and is independent of acid-base balance (39).

The incidence of adverse effects following a single intravenous administration of furosemide is rare (3, 40). Nausea, vomiting, and dizziness may be observed occasionally. Use of furosc-

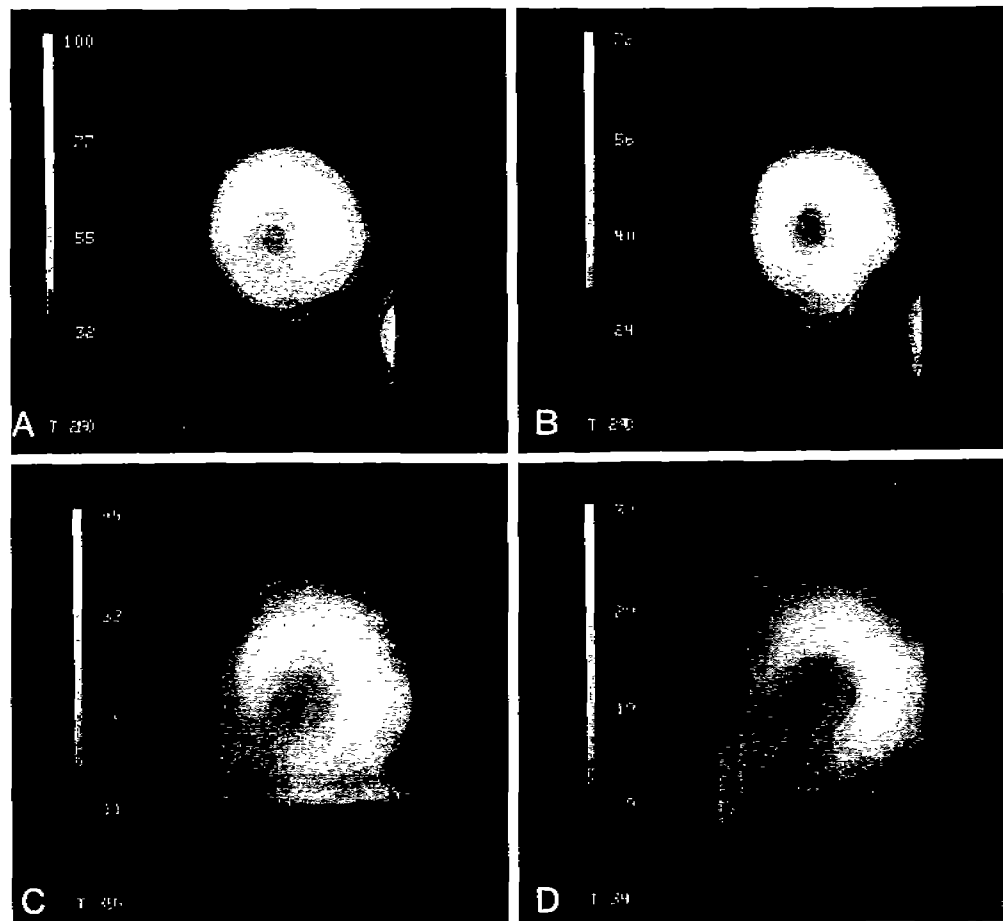

Figure 10.2. Interventional studies with dipyridamole in myocardial scintigraphy with ^{201}Tl illustrate myocardial ischemia (A and B) and infarction (C and D). A and C indicate scintigraphy after dipyridamole administration, and B and D indicate redistribution 4 hours later. (Courtesy of Raymundo T. Go, M.D., Cleveland Clinic Foundation, Cleveland, OH.)

mid is contraindicated in patients with any condition associated with fluid or electrolyte loss (i.e., dehydration, hypotension, hypokalemia, electrolyte imbalance) and in patients with anuric renal failure. The potassium depletion associated with furosemide administration may produce cardiotoxic effects in patients allergic to sulfonamides (39).

The interventional administration of furosemide has been combined with renal scintigraphy with ^{99m}Tc -diethylenetriaminepentaacetic acid (DTPA) and/or ^{123}I - or ^{131}I -labeled *o*-iodohippurate (OIH) in order to differentiate between mechanical obstruction or muscular atony as a cause of upper urinary tract dilation (3, 41-47). This determination is important, since renal atrophy can occur if mechanical obstruction is not surgically corrected, whereas muscular atony can be treated with pharmacologic agents.

This interventional procedure is based on the hypothesis that the "reservoir effect" (prolonged retention of urine) associated with the nonobstructed, functionally abnormal renal collecting system will respond to diuretic administration with increased urine flow and prompt washout of contents. Hence, in the dilated non-obstructed system the ^{99m}Tc -DTPA or ^{123}I - or ^{131}I -labeled OIH renogram curve will demonstrate a prolonged plateau consistent with the reservoir effect, but following the intravenous administration of furosemide (0.3-0.5 mg/kg) a rapid washout of this activity will be observed (Fig. 10.3). In contrast, a mechanically obstructed system will demonstrate a prolonged renogram plateau which does not respond to furosemide administration (3, 40, 42).

Although this technique is highly sensitive (approximately 90%) for the differentiation of mechanical obstruction versus nonobstruction as a cause of upper urinary tract dilatation (44, 45), its use becomes severely limited in patients with poor renal function medically unrelated to the collecting system (3, 40). In these patients, the functionally impaired kidneys may not respond or may respond poorly to diuretic administration and, therefore, the technique may not be applicable. Furosemide dosage for these patients should be adjusted to the higher level of the applicable range. Currently, no definite criteria regarding the levels of serum creatinine or

BUN necessary to render the test unreliable have been established. It should be noted, however, that there may be unilateral renal dysfunction with apparently normal BUN or creatinine values. Basically, if these laboratory results are twice normal and/or if the renal collecting structure(s) are not visualized following radiotracer administration, a response failure to diuretic administration should be viewed with caution (3, 40).

GASTROESOPHAGEAL REFLUX

Bethanechol

Bethanechol is a synthetic ester that is chemically and pharmacologically related to acetylcholine and exerts its effects through the stimulation of cholinergic receptors. After oral or subcutaneous administration, its action is primarily muscarinic in nature; nicotinic activity (i.e., cardiovascular side effects) is minimal unless the agent is injected intravenously or intramuscularly. Unlike acetylcholine, bethanechol is stable to hydrolysis by cholinesterase enzymes (48).

The major gastrointestinal actions of bethanechol include an increase in tone and peristaltic activity of the esophagus, stomach, and intestines; an increase in lower esophageal sphincter (LES) pressure; and an increase in pancreatic and gastrointestinal secretions (48).

Figure 10.3. Diuretic renogram. This study was performed in a patient with low back pain and an abnormal intravenous pyelogram which showed a vessel crossing the renal pelvis of the right kidney. The diagnostic problem was to determine whether the vessel was significantly obstructing the renal collecting system. ^{99m}Tc -DTPA was administered, followed by an injection of furosemide (Lasix) several minutes later. Just prior to Lasix administration, the presence of the vessel can be noted on the image (A) as a photon-deficient band (see arrow). When data from the renogram for the right kidney and left kidney (B) are compared, it is obvious that although the right kidney empties slightly slower than the left, there is an adequate drainage response following the administration of Lasix. This pattern of emptying is typical of that seen with a nonobstructed kidney, which differentiates it from obstructive disease which would have shown a much poorer response to the injection of Lasix. (Courtesy of Robert A. Johnson, M.D., Presbyterian Hospital, Albuquerque, NM.)

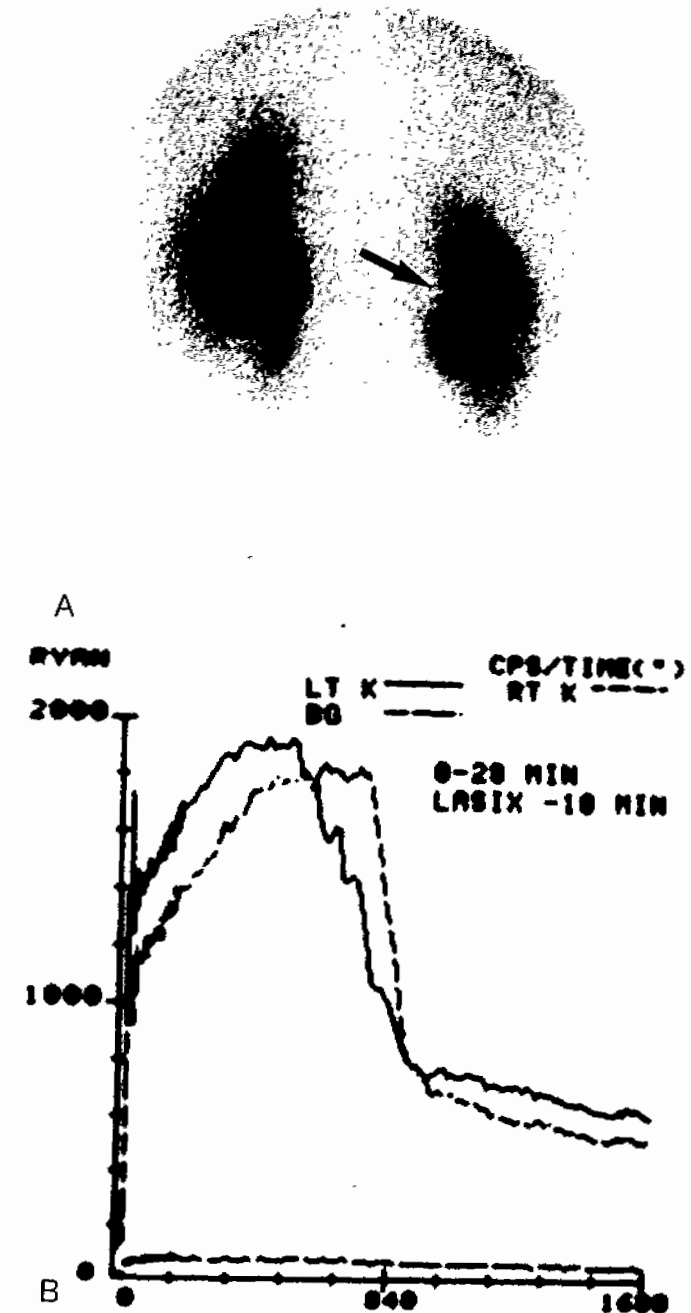

Side effects with oral or subcutaneous administration are usually mild and may include abdominal cramping, diarrhea, nausea or vomiting, headache, sweating, and salivation. The agent is contraindicated in patients with bronchial asthma due to its bronchial constriction effects, in patients with peptic ulcer due to the stimulation of gastrointestinal secretions, and in patients with hyperthyroidism, since it may induce atrial fibrillation (48).

The efficacy of bethanechol for the treatment of gastroesophageal reflux has been directly evaluated and quantitated by gastroesophageal scintigraphy with a solid meal containing ^{99m}Tc -labeled sulfur colloid and/or a liquid meal containing ^{111}In -DTPA or ^{99m}Tc -DTPA (49–52). After subcutaneous administration of 5 mg of bethanechol, the gastric esophageal reflux index (percent of total gastric activity refluxed into the esophagus) decreased from a mean ($n = 10$) of $11.9 \pm 2.4\%$ to means of $8.3 \pm 1.3\%$ ($p < 0.05$), $6.0 \pm 1.3\%$ ($p < 0.01$), and $5.8 \pm 1.7\%$ ($p < 0.01$) at 15, 30, and 45 minutes, respectively. Simultaneous direct measurements of LES pressure revealed corresponding significant increases from 8.9 ± 0.08 mm Hg to 14.3 ± 1.9 mm Hg ($p < 0.01$), 18.5 ± 1.9 mm Hg ($p < 0.001$), and 17.4 ± 2.1 mm Hg, respectively, which thus corroborated the proposed mechanisms of action of this agent in reducing reflux (50). These results were substantiated when directly opposite effects were noted following intravenous administration of the anticholinergic (bethanechol antagonist) agent, atropine. Hence, anticholinergic drugs are contraindicated in patients with heartburn due to gastroesophageal reflux.

Antacids

The predominant pharmacologic action of antacids is the reduction of intragastric pH. Hence, the efficacy of antacids in the management of gastroesophageal reflux may be due to a direct increase in LES pressure resulting from reduced stomach acidity (53), the relief of reflux symptoms associated with the irritating effects of acid, or a combination of these or may be due to alternate mechanisms.

As with bethanechol, the effects of oral antacid (30 ml aluminum hydroxide gel) on gastro-

esophageal reflux have been directly evaluated and quantitated with use of gastroesophageal scintigraphy and have been compared with its effects on LES pressure (49, 50, 53). A significant ($p < 0.01$) decrease (from $11.2 \pm 1.3\%$ to $7.7 \pm 1.0\%$, $n = 15$) in the gastroesophageal reflux index did not occur until 30 minutes following administration, which corresponded to a significant ($p < 0.01$) decrease in LES.

Gaviscon

Gaviscon, a preparation containing alginic acid and a combination of antacids (sodium bicarbonate, aluminum hydroxide, magnesium trisilicate), is indicated in the symptomatic treatment of gastroesophageal reflux (54). Its dual mechanism of action is believed to be due to antacid-induced reduction of intragastric pH and the formation of an alginic acid barrier to reflux which is associated with its floating, viscous properties (55).

Quantitative gastroesophageal scintigraphy demonstrated a significant ($p < 0.05$) decrease (from $9.9 \pm 1.3\%$ to $6.5 \pm 0.8\%$) in the gastroesophageal reflux index at 5 minutes following the oral administration of 4 Gaviscon tablets (49, 50, 53, 55). There was no corresponding increase in LES pressure. Additional studies, performed with ^{87m}Sr -labeled alginic acid, revealed that the majority of the administered preparation remained at the top half of the stomach and that the alginic acid appeared to be refluxed preferentially to the gastric liquid contents (55). Thus it was demonstrated *in vivo* that Gaviscon reduces reflux due to its "barrier" (floating, foaming, and viscous) nature and prevents the associated symptoms by being refluxed preferentially to gastric acid.

GASTRIC EMPTYING STUDIES

Metoclopramide

Metoclopramide, a derivative of procainamide, promotes gastric emptying by increasing the tone and amplitude of gastric contractions, relaxing the pyloric sphincter and duodenal bulb, and increasing peristalsis of the duodenum and jejunum. It apparently exerts these effects by sensitizing the gastric smooth muscle to the actions of the neurotransmitter, acetylcholine. Metoclopramide also increases the resting

tone of the LES. It does not stimulate gastric, biliary, or pancreatic secretions; nor does it significantly affect the motility of the colon or gallbladder. Metoclopramide can produce central nervous system effects via antagonism of dopaminergic receptors (54).

Metoclopramide-induced side effects are rare and are primarily associated with the central nervous system (dopaminergic) effects of the drug. These adverse reactions include somnolence, fatigue, lassitude and, in the severe form, extrapyramidal symptoms including acute dystonic reactions. In view of these latter effects, the drug is contraindicated in patients with epilepsy and in patients on active phenothiazine therapy. Metoclopramide may induce extensive catecholamine release in the presence of pheochromocytoma. It should be noted that narcotics and other analgesics or mechanical obstruction can counteract the effects of metoclopramide on gastric motility (54).

That there must be some cholinergic activity for the expression of the pharmacologic actions of metoclopramide explains the failure of the drug to stimulate gastric emptying in certain subjects. The scintigraphic evaluation and/or quantification of gastric emptying rates with use of radioactive solid or liquid meal, which is performed prior to and following the administration of metoclopramide, provides a direct method of monitoring the effectiveness of metoclopramide and of predicting response to chronic oral therapy (56–58). Such rationalization of therapy is important in consideration of the potential for relatively severe central nervous system side effects. In a study by Domstad et al. (56), intravenous metoclopramide (10 mg) significantly shortened the biologic gastric emptying time in 9 of 12 patients with severe diabetic gastroparesis. In a similar study performed on patients with scintigraphically proven gastroparesis, administration of oral metoclopramide (10 mg given four times daily) resulted in an improvement in gastric emptying in 60% of patients with no previous surgery and in 75% of surgical patients (57). Significant improvements in the gastric emptying rate following oral or intravenous metoclopramide have been scintigraphically demonstrated in patients with gastroesophageal reflux (59).

GASTROINTESTINAL BLEEDING

Glucagon

Glucagon is a single, straight-chain polypeptide that is produced by the α cells of the pancreatic islet of Langerhans and is isolated during the commercial production of insulin. Since the hormonal actions of glucagon are opposite to those of insulin, glucagon is traditionally administered to increase blood glucose levels in the emergency treatment of diabetic insulin overdose. As an interventional agent for nuclear medicine and/or radiology studies, however, glucagon is administered (0.1–1 U intravenously) because of its secondary ability to inhibit gastrointestinal peristalsis by causing relaxation of the smooth muscle of the stomach, duodenum, small bowel, and colon. After intravenous injection (0.5 U), its actions in this regard are rapid in onset (1–2 minutes) and transient in duration (9–17 minutes). The duodenum is most sensitive to the effects of glucagon; the stomach is least sensitive (59, 60).

Adverse reactions following the intravenous injection of glucagon are infrequent and may include nausea, vomiting, headache, and metallic taste. For inhibition of gastrointestinal peristalsis, the injection of glucagon is probably associated with less adverse effects than the administration of anticholinergics. Commercial glucagon is a foreign protein that can produce hypersensitivity reactions. The injection of glucagon should, of course, be avoided in patients with diabetes and in patients with pheochromocytomas or insulinomas, due to its ability to stimulate catecholamine and insulin release, respectively. Glucagon can enhance the hypoprothrombinemic response to warfarin (59).

Gastrointestinal bleeding sites are detected by abdominal scintigraphy following intravenous administration of ^{99m}Tc -labeled sulfur colloid (61) or ^{99m}Tc -labeled red blood cells (62). Interpretation of scintigraphs, however, may become difficult due to diffuse background activity caused by peristalsis (58). Hence, transient interventional inhibition of gastrointestinal peristalsis may improve the scintigraphic detection of the gastrointestinal bleeding sites.

In gastrointestinal bleeding studies per-

formed by Froelich et al. (62), 12 of 24 patients were noted to have abnormally increased, diffuse activity in the abdominal region. After the intravenous administration of glucagon (1 U), a focal accumulation of activity was observed in the small bowel of 6 of these patients. Small-bowel bleeding sites were subsequently confirmed in 4 of these 6 patients and were presumed to be the origin of bleeding in the remaining 2. This preliminary study suggests that the routine interventional use of glucagon may enhance the accuracy of gastrointestinal bleeding studies by preventing the migration of activity from the bleeding site and by improving target-to-background radioactivity ratios.

Vasopressin

Vasopressin is a polypeptide hormone supplied as an aqueous solution of an extract of the posterior pituitary gland. Its activity is standardized by assay against a U.S.P. reference pressor unit. Vasopressin, when infused intravenously or intraarterially (superior mesenteric artery), acts directly on the smooth muscle of the splanchnic vascular bed to produce intense arteriolar and capillary vasoconstriction with significant and sustained reduction of splanchnic blood flow (63). Because of this direct splanchnic vasoconstriction activity, low-dose (0.1 U/min) infusions of vasopressin have been used therapeutically to control bleeding within the gastrointestinal tract (63, 64). In this regard, systemic intravenous infusions appear to be equally effective and are less invasive in nature to superior mesenteric artery infusions (64, 65).

Large doses of vasopressin (i.e., 1 U/min intravenously) can produce significant coronary side effects including cardiac arrhythmias and severe reductions in cardiac output secondary to diminished coronary artery flow (66). At the lower doses (0.2 U/min) used typically to control gastrointestinal bleeding, some patients may develop non-dose-dependent cardiac side effects including hypertension, bradycardia, and arrhythmias. The drug is, therefore, contraindicated in any patient with a history of cardiovascular disease. Water retention and electrolyte imbalance typically occur after vasopressin administration, as do minor abdominal cramping

Scintigraphic gastrointestinal bleeding studies provide a convenient, noninvasive method for directly evaluating the therapeutic efficacy of intravenous or intraarterial vasopressin infusion (63). Baseline studies to demonstrate the bleeding site are performed prior to vasopressin intervention, followed by a repeat study at 1 hour after initiation of therapy. Additional images may be obtained at several time intervals in order to make clinical decisions regarding cessation of therapy, vasopressin dosage increases, or the use of alternate therapeutic modalities (i.e., embolization, surgery).

MECKEL'S DIVERTICULUM

Pentagastrin

Pentagastrin is a synthetic polypeptide that contains the pharmacologically active C-terminal tetrapeptide sequence found in the natural hormone, gastrin. Like gastrin, pentagastrin excites the oxyntic cells of the stomach to stimulate the secretion of acid, pepsin, and intrinsic factor. It also produces an increase in blood flow to the gastric mucosa (67). These combined effects explain the use of pentagastrin to promote the increased localization of sodium [^{99m}Tc]pertechnetate in the gastric mucosa of Meckel's diverticulum. It should be noted, however, that high doses of pentagastrin may actually inhibit gastric acid secretion (67) and counteract the desired interventional effect. Pentagastrin stimulates gastric smooth muscle, which results in an increase in gastric motility and migration of activity from the site of diverticulum secretion (67). Hence, its use should be combined with a gastrointestinal hypotonic agent such as glucagon (vide infra).

Adverse reactions associated with the subcutaneous administration of pentagastrin are transient and mild and primarily consist of nausea, vomiting, tachycardia, and palpitations. The agent is contraindicated for repeated use in the presence of acute peptic ulcers and pancreatic, hepatic, and biliary disease (67).

It has been reported that the subcutaneous administration of pentagastrin (6 mg/kg) 15 minutes prior to the intravenous injection of sodium [^{99m}Tc]pertechnetate permitted the visualization of a Meckel's diverticulum that was not observed previously (68). Support for fur-

ther clinical evaluation of this technique is based on animal studies which have demonstrated that prior administration of pentagastrin accelerated the accumulation of activity in the ectopic gastric mucosa of experimental Meckel's diverticulum (69). This activity rapidly migrated from the diverticulum site, however, which resulted in poor target-to-background radioactivity ratios unless glucagon (vide infra) was coadministered with pentagastrin. After pentagastrin administration, the duodenum was consistently visualized earlier and intensely and often obscured activity in the ectopic gastric mucosa.

Glucagon

Studies in an animal model provide support for the interventional administration of glucagon in the clinical evaluation of Meckel's diverticulum (69). In these studies compared with the control noninterventional studies, administration of only glucagon increased target-to-background radioactivity ratios. Glucagon administered with pentagastrin resulted in early (10 minutes) visualization of the ectopic gastric mucosa with a continual increase in the intensity of activity and ease of visualization. Duodenal interference or washout of activity was not observed. It has been speculated that glucagon exerted these effects by inhibiting gastric motility and preventing translocation of activity secreted by the ectopic mucosa and/or by preventing an increase in background activity due to the discharge of normal ^{99m}Tc stomach activity into the small bowel (69).

Cimetidine

Although cimetidine has not been evaluated clinically, it has been proposed that cimetidine may augment the diagnosis of Meckel's diverticulum by preventing the appearance of normal ^{99m}Tc stomach activity in the small bowel and thus decreasing potential background activity (69). In this regard, animal studies have demonstrated that the excretion of sodium [^{99m}Tc]pertechnetate from the gastric mucosa into the gastric contents is inhibited by prior administration of cimetidine (70).

Cimetidine, a guanidine derivative, blocks both basal and stimulated (i.e., food, betazole, pentagastrin, caffeine, insulin) gastric acid secre-

tion by competitively inhibiting the action of histamine at the H₂ receptors of the parietal cells of the gastric mucosa (71). It does not exert anticholinergic actions, nor does it have an effect on LES pressure or gastric emptying rate (54).

Side effects associated with the administration of cimetidine include mild and transient diarrhea, dizziness, and headache (which may be severe). The drug can potentiate the effects of warfarin anticoagulants by reducing their rate of hepatic metabolism (54).

HEPATOBIILIARY SYSTEM

Phenobarbital

Phenobarbital, a barbiturate more commonly used for its anticonvulsant and sedative properties, has been noted to be effective in the treatment of neonatal hyperbilirubinemia in those newborns with patent extrahepatic ducts (72). It has also been used to lower serum bilirubin levels in patients with congenital nonhemolytic unconjugated hyperbilirubinemia or chronic intrahepatic cholestasis (72).

Phenobarbital enhances the biliary conjugation and excretion of bilirubin (73). The drug is known to increase the hepatic extraction (absorption) of ^{99m}Tc -labeled iminodiacetic acid (IDA) derivatives (74) and other compounds and to increase canalicular bile flow (75, 76). Although phenobarbital stimulates the enzymatic glucuronidation of bilirubin by hepatic microsomes (77), the choleric effect of the drug is thought to be independent of this phenomenon (78, 79), in part because it promotes the excretion of organic anions such as the IDA compounds which are not conjugated by the liver (80). Furthermore, phenobarbital has been shown to stimulate hepatic Na- and/or K-dependent ATPase activity (81), which is thought to play an additional role in organic anion clearance (82). Therefore, phenobarbital apparently acts on the entire hepatic transport system for organic anions (83).

The adverse effects of phenobarbital on the central nervous system include lethargy, drowsiness, vertigo, headache, and depression. Hypersensitivity reactions to barbiturates occur most frequently in patients with asthma, urticaria, or angioedema. Phenobarbital apparently

causes rashes more often than do other barbiturates. Gastrointestinal side effects include nausea, vomiting, diarrhea, and constipation (72). The safety of long-term phenobarbital therapy in children and infants, including newborns, has been established (84, 85).

Phenobarbital is used in conjunction with hepatobiliary imaging primarily to increase the diagnostic accuracy of differentiating between neonatal hepatitis and biliary atresia. Decreased morbidity and decreased mortality are obtainable when extrahepatic biliary obstruction is diagnosed and surgically corrected within the first 2 months of life (86). Without the administration of phenobarbital, the transport of radiotracer through the biliary system is very slow in neonates with hepatitis, although the biliary tract is patent. If radioactivity in the bowel is not visualized within a reasonable time (24 hours), it is virtually impossible to distinguish hepatitis from atresia on the basis of radionuclide imaging. When cholescintigraphy is inconclusive, surgeons must resort to laparotomy in order to make the diagnosis; this is particularly unfortunate for those babies who are found to have jaundice unassociated with atresia. Because of this situation, any test that could help avoid unnecessary surgery is certainly useful. In this regard, the intervention of phenobarbital with cholescintigraphy has significantly improved the sensitivity and specificity of the test for determining the cause of neonatal jaundice, simply by increasing the rate of excretion of ^{99m}Tc -IDA and thus by allowing earlier visualization of bowel in the presence of patent biliary ducts (83).

Phenobarbital used as a pharmacologic intervention with radionuclide hepatobiliary studies is administered in doses of approximately 5 mg/kg/day for at least 5 days prior to the imaging procedure ((83). Imaging is carried out to at least 24 hours following the injection of a ^{99m}Tc -IDA derivative. The clinician should look not only for the appearance of bowel activity but also for poor hepatic uptake of the radiotracer as evidence for neonatal hepatitis (83). Alternatively, some physicians prefer to measure the presence or absence of radioactivity in the bowel by taking samples of duodenal fluid at various time intervals postinjection (87).

Cholecystokinetic Agents

Although cholecystokinin (88–93), sincalide (3, 94–110), and ceruletide (111) have been used in nuclear medicine to induce contraction and subsequent filling of the gallbladder, only sincalide is readily available to clinicians practicing in the United States. Therefore, sincalide will be discussed as being representative of the cholecystokinetic agents.

Sincalide (Kinevac) is the synthetic C-terminal octapeptide of the hormone cholecystokinin and is similar to cholecystokinin in pharmacologic action. It causes gallbladder contractions resulting in both reduction of gallbladder size and evacuation of gallbladder contents (112). The administration of this drug also results in decreased esophageal sphincter tone, decreased intestinal transit time, inhibition of gastric secretions, stimulation of pancreatic secretions, and delayed gastric emptying (112).

Adverse effects of sincalide are usually associated with the pharmacologic action of the drug and include nausea, abdominal pain or discomfort, dizziness, flushing, and an urge to defecate. These effects usually occur almost immediately after injection and may last for several minutes (112).

With use of noninterventional methods, the diagnosis of cholecystitis can be made with an extremely high degree of accuracy when imaging is carried out for at least 4 hours following the administration of a ^{99m}Tc -IDA compound (113). Persistent nonvisualization of radioactivity in the gallbladder over this 4-hour period is suggestive of acute cholecystitis, whereas delayed visualization of the gallbladder at 1½–4 hours is more typical of chronic cholecystitis (113). Alternatively, some physicians prefer to conclude imaging at 60–90 minutes after injection of radiotracer, with the attendant risks of making a few false positive diagnoses when the gallbladder is not seen within this shortened time frame and of missing chronic cholecystitis which otherwise would have presented as delayed gallbladder filling in some patients.

The rationale for use of sincalide with cholescintigraphy is to empty the gallbladder and thereby remove any functional resistance to the flow of radiotracer through the cystic duct

which may result in nonfilling of the gallbladder. This nonfilling usually is associated with the presence of excessively viscous bile and sludge secondary to chronic cholecystitis (113), prolonged fasting (100), or long-term parenteral nutrition therapy (114). The usefulness of this intervention depends on the time, in relation to the injection of the radiopharmaceutical and subsequent imaging, that sincalide is administered. Two approaches have been suggested (95).

With one approach, patients are premedicated with sincalide prior to injection of the radiopharmaceutical. This intervention promotes earlier visualization of the gallbladder in patients with patent cystic ducts, which thus decreases the imaging time required to diagnose or exclude acute cholecystitis (from 4 hours to less than 1 hour) and simultaneously avoids false positives that may occur if the abbreviated imaging procedure (without sincalide) is used. There is some concern, however, that sincalide, if routinely given prior to imaging, may obscure the diagnosis of chronic cholecystitis or mask the small percentage of cases in which acute cholecystitis may present as delayed gallbladder visualization (95).

Another approach is to administer sincalide only if the gallbladder does not initially fill within 1 hour, followed by another injection of ^{99m}Tc -IDA. If the gallbladder still does not fill after an additional hour, the patient is considered to have acute cholecystitis; if the gallbladder is observed now, chronic cholecystitis is suspected (95). This method has been shown to be as effective as delayed imaging (without sincalide) in detection of chronic cholecystitis (95). A disadvantage of the procedure, however, is that the radiation-absorbed dose is doubled in those patients who receive a second dose of the radiopharmaceutical (80).

It has been observed that in some patients with acute acalculous cholecystitis, the gallbladder is visualized on cholescintigraphy studies (94, 96). Sincalide has been used as an adjunct to the examination of these patients who, despite normal filling of the gallbladder, remain suspect of having acute cholecystitis, due to their clinical presentation. In these patients, the effectiveness of gallbladder contrac-

tion is observed (or, preferably, quantitated) (Fig. 10.4). Patients with acute acalculous cholecystitis will have a distinctly abnormal response, usually with a gallbladder ejection fraction of much less than 20% (80, 106).

The usual dose of sincalide is 0.02 $\mu\text{g}/\text{kg}$ given intravenously. Although most investigators have administered the drug by slow (1–3 minutes) intravenous push, Sarva et al. (107) have found that more complete emptying of the gallbladder is obtainable with a 45-minute infusion of the drug.

The peak contractile response after an intravenous push dose is usually seen at 5–15 minutes, with the gallbladder returning to the basal size within 1 hour (112); therefore, it is necessary to wait approximately 30–60 minutes after sincalide administration before the ^{99m}Tc -IDA compound is injected (104).

Sincalide has essentially replaced the use of a fatty meal as a means to induce gallbladder contraction, primarily because the response to the drug is more predictable (80).

SPLEEN

Epinephrine

Among its many other pharmacologic actions, epinephrine causes the spleen to decrease in volume (115), a phenomenon which may be related to "expulsion" of contained blood elements (116). Since the spleen does not have a muscular coat in the splenic capsule, the contractile response may be mediated within the spleen and its blood vessels (116). More specifically, it may be due to variable rates of blood flow as the smooth muscle of terminal arteries and arterioles respond to epinephrine (117). A decrease in blood flow, along with normal sinusoidal and capsular elasticity, could explain the volumetric change (117).

Although more clinical studies are necessary to confirm the true value of epinephrine, the intervention with epinephrine in splenic imaging may potentially provide a noninvasive method to assess splenic involvement of Hodgkin's disease. Two groups of authors have shown that the volume response to epinephrine appears to be significantly less in abnormal spleens than in normal spleens (117, 118). Theoretically, neoplastic infiltration of red and

TIME=072771 VIEW=!@@ SCA=0500000

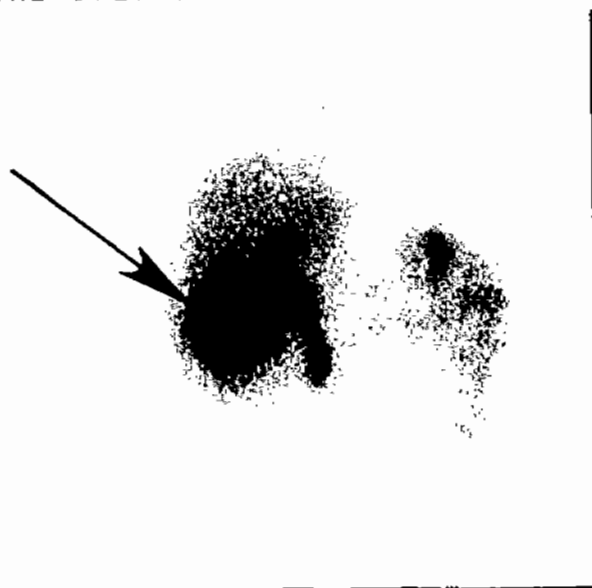

A

WHITE=000 GRAY=088 BLACK=087

TIME=072122 VIEW=!@@ SCA=0500000

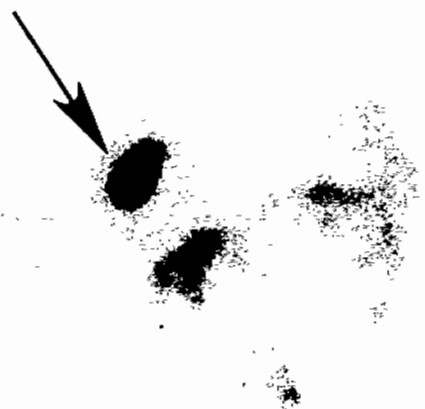

B

WHITE=000 GRAY=256 BLACK=255

white splenic pulp would decrease both the volume of the splenic sinusoids and their elasticity, which would thus result in the diminished volume responses noted in these studies (117).

A range of 0.5–1.0 mg of epinephrine has been used as an interventional dose by investigators (117, 118). Epinephrine is known to cause a variety of adverse effects, and the reader is referred to other sources for more detailed information on this subject (119).

REFERENCES

- Domstad PA: Extension of radionuclide methods by adjunctive pharmacologic intervention: an approach yielding improved diagnostic capability. *J Nucl Med* 21:700–701, 1980.
- Henkin RE: It is time for us to intervene. *J Nucl Med* 21:1105–1106, 1980.
- Thrall JH, Swanson DP: Interventional aspects of nuclear medicine. In Freeman LM, Weissman HS (ed): *Nuclear Medicine Annual*. New York, Raven Press, 1983, pp 1–49.
- Hamilton JG: Rates of absorption of reactive sodium, potassium, chlorine, bromine, and iodine in normal human subjects. *Am J Physiol* 124:667–678, 1938.
- Hamilton JG, Soley MH: Studies in iodine metabolism by the use of a new radioactive isotope of iodine. *Am J Physiol* 127:557–573, 1939.
- Hamilton JG, Soley MH: Studies in iodine metabolism of the thyroid gland in situ by the use of radioiodine in normal subjects and in patients with various types of goiter. *Am J Physiol* 131:135–143, 1940.
- Dresner S, Schneeberg NL: Rapid radioiodine suppression test using triiodothyronine. *J Clin Endocrinol Metab* 18:797–799, 1958.
- Oddie TH, Rundle FF, Thomas ID, et al: Quantitative observations with the thyroxine suppression test of thyroid function. *J Clin Endocrinol Metab* 20:1146–1157, 1960.
- Watanabe T: Modificación del yodo proteico radioactivo producida por la hormona liberadora de tirotropina. *Rev Biol Med Nucl* 7:103–106, 1975.
- Jeffreys WM, Levy RP, Storaasli JP: Use of the TSH test in the diagnosis of thyroid disorders. *Radiology* 73:341–344, 1959.
- Taunton OD, McDaniel HG, Pitman JA Jr: Standardization of TSH testing. *J Clin Endocrinol Metab* 25:266–277, 1965.
- Krishnamurthy GT: Human reaction to bovine TSH. *J Nucl Med* 19:284–286, 1978.
- Stanbury JB, Wyngaarden JB: Effect of perchlorate on the human thyroid gland. *Metabolism* 1:533–539, 1952.
- Baschieri L, Beneditti G, DeLuca F, et al: Evaluation and limitations of the perchlorate test in the study of thyroid function. *J Clin Endocrinol Metab* 23:786–791, 1963.
- Steward RDH, Murray IPC: An evaluation of the perchlorate discharge test. *J Clin Endocrinol Metab* 26:1050–1058, 1966.
- Beierwaltes WA, Lieberman LM, Ansari AN, et al: Visualization of human adrenal glands in vivo by scintillation scanning. *JAMA* 216:275–277, 1971.
- Lieberman LM, Bierwaltes WH, Conn JW, et al: Diagnosis of adrenal disease by visualization of human adrenal glands with 19-iodocholesterol. *N Engl J Med* 285:1387–1393, 1971.
- Sarkar SD, Beirwaltes WH, Ice RD, et al: A new and superior adrenal scanning agent, NP-59. *J Nucl Med* 16:1038–1135, 1979.
- Gross MD, Freitas JE, Swanson DP, et al: The normal dexamethasone adrenal scintiscan. *J Nucl Med* 20:1131–1135, 1979.
- Gross MD, Valk TW, Swanson DP, et al: The role of pharmacologic manipulation in adrenal cortical scintigraphy. *Semin Nucl Med* 11:128–148, 1981.
- Freitas JE, Grekin RJ, Thrall JH, et al: Adrenal imaging with iodomethylnorcholesterol (I-131) in primary aldosteronism. *J Nucl Med* 20:7–10, 1979.
- Gregg DE: The George E. Brown Memorial lecture: physiology of the coronary circulation. *Circulation* 27:1128–1137, 1963.
- American Hospital Formulary Service—Drug Information '85*. Vasodilating agents (24:12). Bethesda, MD, American Society of Hospital Pharmacists, 1985, pp 695–696.
- Hamilton GW, Narahara KA, Yee H, et al: Myocardial imaging with thallium-201; effect of cardiac drugs on myocardial images and absolute tissue distribution. *J Nucl Med* 19:10–16, 1978.
- Gould KL, Westcott RJ, Albro PC, et al: Noninvasive assessment of coronary stenoses by myocardial imaging during pharmacologic coronary vasodilation. II. Clinical methodology and feasibility. *Am J Cardiol* 41:279–287, 1978.
- Sklar J, Kirsh D, Routh J, et al: Differences in thallium redistribution after exercise and dipyridamole infusion (abstract). *J Nucl Med* 22:P41, 1981.
- Sochor H, Pochinger O, Ogris E, et al: Comparison of thallium-201 myocardial imaging and regional wall motion studies after coronary vasodilation with dipyridamole (abstract). *J Nucl Med* 22:P17, 1981.
- Demangeat JL, Constantinesco A, Mossard JM, et al: Evaluation of myocardial perfusion and left ventricular

Figure 10.4. Hepatobiliary study with use of a cholecystokinetic agent. *A:* Gallbladder fills normally following the injection of ^{99m}Tc -labeled diisopropyl iminodiacetic acid (DISIDA). Ceruletide is administered at this time. *B:* Contractile response of gallbladder to ceruletide is considered normal, since an ejection fraction of greater than 50% is observed; it is therefore unlikely that the patient has acalculous cholecystitis. (Courtesy of Robert A. Johnson, M.D., Presbyterian Hospital, Albuquerque, NM.)

- function by 201:Tl scintigraphy after dipyridamole. *Eur J Nucl Med* 6:491-503, 1981.
29. Schmoliner R, Dudeczak R, Kronik G, et al: Thallium-201 imaging after dipyridamole in patients with proximal or distal LAD stenoses (abstract). *J Nucl Med* 23:P82, 1982.
 30. Josephson MA, Brown BG, Hect HS, et al: Non-invasive detection and localization of coronary stenoses in patients. Comparison of resting dipyridamole and exercise thallium-201 myocardial perfusion imaging. *Am Heart J* 103:1008-1018, 1982.
 31. Salel AF, Berman DS, DeNardo GL, et al: Radionuclide assessment of nitroglycerin influence on abnormal left ventricular segmental contraction in patients with coronary heart disease. *Circulation* 53:979-981, 1976.
 32. Rosanski A, Berman D, Levy R, et al: The administration of nitroglycerin (abstract). *J Nucl Med* 22:P83, 1981.
 33. Borer JS, Bacharach SL, Green MV, et al: Effect of nitroglycerin on exercise induced abnormalities of left ventricular regional function and ejection fraction in coronary artery disease. Assessment by radionuclide cineangiography in symptomatic and asymptomatic patients. *Circulation* 57:314-320, 1978.
 34. Buda AJ: Physiologic stress interventions in cardiac imaging. In Thrall JH, Swanson DP (eds): *Diagnostic Interventions in Nuclear Medicine*. Chicago, Year Book Medical Publishers, 1985, pp 7-30.
 35. Strauss HW, McKusick KA, Boucher CA: Interventional nuclear cardiology. In Spencer RP (ed): *Interventional Nuclear Medicine*. New York, Grune & Stratton, 1984 pp 279-286.
 36. Donald KW, Lind AR, McNicol GW, et al: Cardiovascular responses to sustained (static) contractions. *Circ Res* 21(Suppl):1-15, 1967.
 37. Hines EA Jr, Brown GE: Standard stimulus for measuring vasomotor reactions: its application in the study of hypertension. *Proc Staff Meet Mayo Clin* 7:332, 1932.
 38. Sowton GE, Balcon R, Cross D, et al: Measurement of the angina threshold using atrial pacing: a new technique for the study of angina pectoris. *Cardiovasc Res* 1:301, 1967.
 39. *American Hospital Formulary Service—Drug Information '85*. Diuretics (40:28). Bethesda, MD, American Society of Hospital Pharmacists, 1985, pp 1133-1137.
 40. Rado JP, Banos C, Tako J: Renographic studies during furosemide diuresis in partial ureteral obstruction. *Radiol Clin* 38:132, 1969.
 41. O'Reilly PH, Testa HJ, Lawson RS, et al: Diuresis renography in equivocal urinary tract obstruction. *Br J Urol* 50:76-80, 1978.
 42. O'Reilly PH, Lawson RS, Shields RA, et al: Idiopathic hydronephrosis—the diuresis renogram: a new non-invasive method of assessing equivocal pelviureteral junction obstruction. *J Urol* 121:153-155, 1979.
 43. Koff SA, Thrall JH, Keyes JW Jr: Diuretic radionuclide urography: a non-invasive method for evaluating nephroureteral dilatation. *J Urol* 122:451-454, 1979.
 44. Koff SA, Thrall JH, Keyes JW Jr: Assessment of hydronephrosis in children using diuretic radionuclide urography. *J Urol* 123:531-534, 1980.
 45. Thrall JH, Koff SA, Keyes JW Jr: Diuretic radionuclide urography in the differential diagnosis of hydronephrosis. *Semin Nucl Med* 11:89, 1981.
 46. Koff SA, Kogan B, Kass EJ, et al: Early post-operative assessment of the functional patency of the ureterovesical junction following ureteroneocystostomy. *J Urol* 125:554, 1981.
 47. MacGregor RJ, Konnak JW, Thrall JH, et al: Diuretic radionuclide urography in the diagnosis of suspected ureteral obstruction following renal transplantation. *J Urol* 129:710-798, 1983.
 48. *American Hospital Formulary Service—Drug Information '85*. Parasympathomimetic agents (12:04). Bethesda, MD, American Society of Hospital Pharmacists, 1985, pp 419-421.
 49. Malmud LS, Fisher RS: Radionuclide studies of esophageal transit and gastroesophageal reflux. *Semin Nucl Med* 12:104-115, 1982.
 50. Malmud LS, Fisher RS: The evaluation of gastroesophageal reflux before and after medical therapies. *Semin Nucl Med* 11:205-215, 1981.
 51. Malmud LS, Fisher RS: Quantitation of gastroesophageal reflux before and after therapy using the gastroesophageal scintiscan. *South Med J* 71(Suppl):10-15, 1978.
 52. Malmud LS, Fisher RS, Lobis I, et al: Quantitation of gastroesophageal (GE) reflux before and after therapy using the GE scintiscan (abstract). *J Nucl Med* 17:559-560, 1976.
 53. Fisher RS: Lower esophageal sphincter as a barrier to gastroesophageal reflux before and after surgery. *South Med J* 71(Suppl):22-25, 1978.
 54. Malmud LS, Charkes ND, Littlefield J, et al: The mode of action of alginate acid compound in the reduction of gastroesophageal reflux. *J Nucl Med* 20:1023-1028, 1979.
 55. Kastrup EK (ed): *Facts and Comparisons*. St Louis, MO, Facts and Comparisons, 1985.
 56. Domstad PA, Kim EE, Coupal JJ, et al: Biological gastric emptying time in diabetic patients using Tc-99m labeled resin oatmeal with and without metoclopramide. *J Nucl Med* 21:1098-1100, 1980.
 57. Pellegini CA, Broderick WC, VanDyke D, et al: Diagnosis and treatment of gastric emptying disorders: clinical usefulness of radionuclide measurements of gastric emptying. *Am J Surg* 145:143-151, 1983.
 58. McCallum RW, Fink SM, Lerner E, et al: Effects of metoclopramide and bethanechol on delayed gastric emptying present in gastroesophageal reflux patients. *Gastroenterology* 84:1573-1577, 1983.
 59. *American Hospital Formulary Service—Drug Information '85*. Miscellaneous antidiabetic agents (68:20.92). Bethesda, MD, American Society of Hospital Pharmacists, 1985, pp 1432-1434.
 60. Alavi A: Detection of gastrointestinal bleeding with ^{99m}Tc-sulfur colloid. *Semin Nucl Med* 12:126-138, 1982.
 61. Winzelberg GG, McKusick KA, Froelich JW, et al: Detection of gastrointestinal bleeding with ^{99m}Tc-labeled red blood cells. *Semin Nucl Med* 12:139-146, 1982.
 62. Froelich JW, Juni JE: Intravenous glucagon as an adjunct for diagnosing bleeding of the small bowel with *in vivo* Tc-99m labeled red blood cells. *Radiology* 151:239, 1984.
 63. Alavi A, McLean GK: Studies of G.I. bleeding with scintigraphy and the influence of vasopressin. *Semin Nucl Med* 11:216-223, 1981.
 64. Johnson WC: Control of varices by vasopressin: prospective radiological study. *Ann Surg* 186:369-376, 1977.
 65. Barr JW, Lakin RC, Rosch J: Similarity of arterial and intravenous vasopressin on portal and systemic hemodynamics. *Gastroenterology* 69:13-19, 1975.
 66. Drapanas T, Crowe CP, Shim WKT, et al: The effect of Pitressin on cardiac output and coronary, hepatic and intestinal blood flow. *Surg Gynecol Obstet* 133:484, 1961.
 67. *American Hospital Formulary Service—Drug Information '85*. Gastric function (36:36). Bethesda, MD, American Association of Hospital Pharmacists, 1985, pp 980-981.
 68. Kilpatrick ZM: Letter to the editor. *N Engl J Med* 291:531, 1974.
 69. Treves S, Grand RJ, Erakis AJ: Pentagastrin stimulation of technetium-99m uptake by ectopic gastric mucosa in a Meckel's diverticulum. *Radiology* 128:711-712, 1978.
 70. Sfakianakis GN, Anderson GF, King DR, et al: The effect of gastrointestinal hormones on the pertechnetate imaging of ectopic gastric mucosa in experimental Meckel's diverticulum. *J Nucl Med* 22:678-683, 1981.
 71. Sagar VV, Piccone JM: The gastric uptake and secretion of Tc-99m pertechnetate after H₂ receptor blockade in dogs (abstract). *J Nucl Med* 21:67, 1980.
 72. *American Hospital Formulary Service—Drug Information '85*. Barbiturates (28:24.04). Bethesda, MD, American Society of Hospital Pharmacists, 1985, pp 911-915, 921-922.
 73. Yaffe SJ, Juchau MR: Perinatal pharmacology. *Ann Rev Pharmacol* 14:219-238, 1974.
 74. Coenegracht JM, Oei TL, van Breda Vriesman PJC: The influence of bilirubin, alcohol, and certain drugs on the kinetics of 99m-Tc diethyl IDA (EHIDA) in humans. *Eur J Nucl Med* 8:140-144, 1983.
 75. Fischer E, Varga F, Gregus Z, et al: Bile flow and biliary excretion rate of some organic anions in phenobarbital pretreated rats. *Digestion* 17:211-220, 1978.
 76. Sharp HL, Mirkin BL: Effect of phenobarbital on hyperbilirubinemia, bile acid metabolism, and microsomal enzyme activity in chronic intrahepatic cholestasis of childhood. *J Pediatr* 81:116-126, 1972.
 77. Conney A: Pharmacologic implications of microsomal enzyme induction. *Pharmacol Rev* 19:317-366, 1967.
 78. Capron JP, Dumont M, Feldman G, et al: Barbiturate-induced cholestasis: possible independence from microsomal enzyme induction. *Digestion* 15:556-565, 1977.
 79. Chivrac D, Dumont M, Erlinger S: Lack of parallelism between microsomal enzyme induction and phenobarbital induced hypercholesterolemia in the rat. *Digestion* 17:516-525, 1978.
 80. Froelich JW, Thrall JH, Swanson DP: Hepatobiliary interventions. In Thrall JH, Swanson DP (eds): *Diagnostic Interventions in Nuclear Medicine*. Chicago, Year Book Medical Publishers, 1985, pp 166-175.
 81. Simon F, Sutherland E, Accatino L: Stimulation of hepatic (Na⁺, K⁺) ATPase activity by phenobarbital: its possible role in regulation of bile flow. *J Clin Invest* 59:849-861, 1977.
 82. Javitt N: Hepatic bile formation II. *N Engl J Med* 295:1511-1516, 1976.
 83. Majd M, Reba R, Altman RP: Effect of phenobarbital on Tc-99m IDA scintigraphy in the evaluation of neonatal jaundice. *Semin Nucl Med* 11:194-204, 1981.
 84. Aiges HW, Daum F, Olson M, et al: The effects of phenobarbital and diphenylhydantoin on liver function and morphology. *J Pediatr* 97:22-26, 1980.
 85. Ghent CN, Bloomer JR, Hsia YE: Efficacy and safety of long-term phenobarbital therapy of familial cholestasis. *J Pediatr* 93:127-132, 1978.
 86. Kasai M, Suzuki H, Ohashi E, et al: Technique and results of operative management of biliary atresia. *World J Surg* 2:571-580, 1978.
 87. Jaw TS, Wu CC, Ho YH, et al: Diagnosis of obstructive jaundice in infants: Tc-99m DISIDA in duodenal juice. *J Nucl Med* 25:360-363, 1984.
 88. Fonseca C, Greenberg D, Rosenthal L: Tc-99m IDA imaging in the differential diagnosis of acute cholecystitis and acute pancreatitis. *Radiology* 130:525-527, 1979.
 89. Fonseca C, Greenberg D, Rosenthal L: Assessment of the utility of gallbladder imaging with Tc-99m IDA. *Clin Nucl Med* 3:437-441, 1978.
 90. Rosenthal L: Hepatobiliary imaging with Tc-99m IDA radiopharmaceuticals. *Clin Nucl Med* 7:44, 1982.
 91. Rosenthal L, Shaffer EA, Lisbona R, et al: Diagnosis of hepatobiliary disease by Tc-99m HIDA cholescintigraphy. *Radiology* 126:467-474, 1978.
 92. Pare P, Shaffer EA, Rosenthal L: Nonvisualization of the gallbladder by Tc-99m HIDA cholescintigraphy as evidence of cholecystitis. *Can Med Assoc J* 118:384-386, 1978.
 93. Eikman EA: Radionuclide hepatobiliary procedures: when can HIDA help? *J Nucl Med* 20:358-360, 1979.
 94. Topper TE, Ryerson TW, Nora PF: Quantitative gallbladder imaging following cholecystokinin. *J Nucl Med* 21:694-696, 1980.
 95. Freeman LM, Sugarman LA, Weissmann HS: Role of cholestokinetic agents in 99mTc-IDA cholescintigraphy. *Semin Nucl Med* 11:186-193, 1981.
 96. Weissmann HS, Berkowitz D, Fox MS, et al: The role of technetium-99m iminodiacetic acid (IDA) cholescintigraphy in acute calculous cholecystitis. *Radiology* 146:177-180, 1983.
 97. London JW, Greenberg A, Alavi A, et al: Automated calculation of gallbladder ejection fraction. *Eur J Nucl Med* 8:307-311, 1983.
 98. Drane WE, Nelp WB, Rudd TG: The need for routine delayed radionuclide hepatobiliary imaging in patients

- with intercurrent disease. *Radiology* 151:763-769, 1984.
99. Fisher RS, Stelzer F, Rock E, et al: Abnormal gallbladder emptying in patients with gallstones. *Dig Dis Sci* 27:1019-1024, 1982.
 100. Larsen MJ, Klingensmith WC III, Kuni CC: Radionuclide hepatobiliary imaging: non-visualization of the gallbladder secondary to prolonged fasting. *J Nucl Med* 23:1003-1005, 1982.
 101. Weissmann HS, Sugarman LA, Frank MS: Serendipity in technetium 99m dimethyl iminodiacetic acid cholescintigraphy. *Radiology* 135:449-454, 1980.
 102. Williams W, Krishnamurthy GT, Brar HS, et al: Scintigraphic variations of normal biliary physiology. *J Nucl Med* 25:160-165, 1984.
 103. Weissmann HS, Frank MS, Bernstein LH, et al: Rapid and accurate diagnosis of acute cholecystitis with 99m-Tc HIDA cholescintigraphy. *AJR* 132:523-528, 1979.
 104. Mesgarzadeh M, Krishnamurthy GT, Bobba VR, et al: Filling, postcholecystokinin emptying, and refilling of normal gallbladder: effects of two different doses of CCK on refilling: concise communication. *J Nucl Med* 24:666-671, 1983.
 105. Weissmann HS, Sugarman LA, Freeman LM: Atlas of Tc-99m iminodiacetic acid (IDA) cholescintigraphy. *Clin Nucl Med* 7:231-239, 1982.
 106. Doherty PW, Schlegel P, King MA, et al: Abnormal gallbladder emptying in response to cholecystokinin (OP-CCK) in patients with acalculous gallbladder disease (abstract). *J Nucl Med* 24:P8-P9, 1983.
 107. Sarva RP, Shreiner DP, van Thiel D, et al: Gallbladder function: methods for measuring filling and emptying. *J Nucl Med* 26:140-144, 1985.
 108. Krishnamurthy GT, Bobba VR, Kingston E: Radionuclide ejection fraction: a technique for quantitative analysis of motor function of the human gallbladder. *Gastroenterology* 80:482-490, 1981.
 109. Krishnamurthy GT, Bobba VR, McConnell D, et al: Quantitative biliary dynamics: introduction of a new noninvasive scintigraphic technique. *J Nucl Med* 24:217-223, 1983.
 110. Krishnamurthy GT, Bobba VR, Kingston E, et al: Measurement of gallbladder emptying sequentially using the single dose of 99m-Tc-labeled hepatobiliary agent. *Gastroenterology* 83:773-776, 1982.
 111. Krishnamurthy GT, Turner FE, Mangham D, et al: Optimization of ceruletide intravenous dose for gallbladder (GB) emptying (abstract). *J Nucl Med* 24:P38-P39, 1983.
 112. *American Hospital Formulary Service—Drug Information '85*. Gallbladder function (36:34). Bethesda, MD, American Society of Hospital Pharmacists, 1985, pp 978-979.
 113. Weissmann HS, Sugarman LA, Freeman LM: The clinical role of technetium-99m iminodiacetic acid cholescintigraphy. In Freeman LM, Weissman HS (eds): *Nuclear Medicine Annual 1981*. New York, Raven Press, 1981.
 114. Shuman WP, Gibbs P, Rudd TG, et al: PIPIDA scintigraphy for cholecystitis: False positives in alcoholism and total parenteral nutrition. *AJR* 138:1-5, 1982.
 115. Spencer RP, Lange RC, Schwartz AD, et al: Radioisotopic studies of changes in splenic size in response to epinephrine and other stimuli. *J Nucl Med* 13:211-214, 1972.
 116. Spencer RP: Splenic response to exercise and medications. In Spencer RP (ed): *Interventional Nuclear Medicine*. New York, Grune & Stratton, 1984, pp 309-319.
 117. Rosen PR, Lasher JC, Weiland FL, et al: Predicting splenic abnormality in Hodgkin disease using volume response to epinephrine administration. *Radiology* 143:627-629, 1982.
 118. Osadchaya TI, Vasilo NI, Baisogolov GD: Diagnosis of splenic involvement in Hodgkin's disease by radionuclide evaluation of splenic contraction in response to adrenaline. *J Nucl Med* 21:384-386, 1980.
 119. *American Hospital Formulary Service—Drug Information '85*. Sympathomimetic agents (12:12). Bethesda, MD, American Society of Hospital Pharmacists, 1985, pp 474-478.

11

Medical Decision Making*David F. Preston and Larry T. Cook*

Making decisions is a central part of a physician's work. We would like to believe that, given a specific set of circumstances, our decisions are correct, appropriate and optimal. The complexity of medicine, however, is such that most of our decisions are made with incomplete information. Even if the total data on a specific clinical situation were available, there is every reason to believe physicians would differ in their approach to seemingly identical problems.

At this time, physicians are asked to demonstrate the appropriateness of their choices of diagnostic and therapeutic maneuvers. Blue Cross-Blue Shield, Medicare, Medicaid, and other third-party payers now question the physician's choice of action. In the near future, we in nuclear medicine will be required to compare our diagnostic abilities with other diagnostic modalities in specific clinical situations, with the hope that the most cost-effective course may be taken. Frequently, the data are found to be little more than opinion and often that opinion is not accepted by physicians in other specialties. Despite such difficulties, a number of formal methods, proven in the areas of business, psychology, and statistics, have been found to be appropriate for complex medical problems. These techniques make it possible to identify, simplify, organize, and measure the important variables of a problem and are considered the tools of medical decision making. The purpose of this chapter is to present several clinical problems, demonstrate their resolution through the use of medical decision techniques, and point out sources for more advanced study.

PROBABILITY

Probability is the chance that a given event will occur. It is expressed as a decimal fraction

with a range between 0.0 (it will never happen) to 1.0 (it will always happen). The probability of encountering a specific disease in a given patient population before any testing is performed is the prior probability of that disease and will vary from practice to practice. The a priori or prior probability of disease is designated P(D). The prior probability P(D) could be determined from the medical records, but many times it is not available and must be estimated by experienced clinicians. Differences in the prior probabilities account for a major cause of disagreement in conclusions between medical researchers studying the same problem at different institutions.

When the prior probability data are not available, one approach is to create a list of diagnostic possibilities from previous experience and to assign a probability to the occurrence of each disease in a particular group. Ideally, the disease states should be mutually exclusive. This requires that the prior probabilities must sum to 1.0. At the University of Kansas Division of Nuclear Medicine, the measured prior probabilities for thyroid status are .05 for hypothyroidism, .84 for euthyroidism, and .11 for hyperthyroidism. These are objective rather than subjective or personal probabilities.

The validity of subjective or personal probabilities is discussed by Lusted (1) and others (2-4). Despite the well-known problems of human investigators estimating subjective probabilities so they are correctly ranked and their total adds to 1.0, with practice and experience in the subject matter, useful results may be obtained (5).

Conditional probabilities P(T+ | D+) describe the frequency with which a test is positive (T+), given (|) the presence of a specific

Table 11.1.
Probability of a Positive Test, Given That the Patient Has the Disease

Test	Hypothyroid			Euthyroid			Hyperthyroid		
	Low*	Normal*	High*	Low*	Normal*	High*	Low*	Normal*	High*
T ₄ RIA	.822	.178	.000	.017	.969	.014	.000	.316	.684
T ₃ resin	.200	.721	.079	.051	.904	.045	.049	.195	.756
T ₃ RIA	.500	.449	.051	.018	.970	.012	.000	.131	.869
ETR	.606	.383	.011	.025	.974	.001	.000	.307	.693
24-hour uptake	.781	.198	.021	.139	.810	.051	.050	.172	.778

* Refers to results of tests, not to the disease state.

disease (D+). For example, in our laboratory the probability of an elevated T₄ radioimmunoassay (RIA) is .684 in the patient with hyperthyroidism, .014 in a patient with euthyroidism, and .000 in a patient with hypothyroidism. More complete information based on 879 patients is shown in Table 11.1. If we assign diagnosis code D1 to hypothyroidism, D2 to euthyroidism, and D3 to hyperthyroidism, the probability of an elevated T₄, given that the patient has hyperthyroidism, is $P(T_4 + | D3) = .684$.

Posterior probabilities or posttest probabilities are the probabilities of a specific disease after a test result is known. One measure of the value of a test is to compare the pretest and posttest probabilities. If testing improves the probability of a diagnosis, the test may have value.

DECISION MATRIX

Many problems in medical decision making require comparison of test results with the presence or absence of disease. The most simple

comparison is to make a 2 × 2 decision matrix as in Table 11.2. The results of individual T₄ determinations are compared with the final known diagnostic state of the patient. The number of elevated T₄s (T+) associated with disease (D+) and without the specific disease (D-) and the number of nonelevated T₄s (T-) associated with disease (D+) and without the specific disease (D-) are seen.

The true positive group (#TP) consists of the number (#) of patients with a positive test (T+) and the disease (D+). The true negative group (#TN) consists of the number of patients with a negative test (T-) and the absence of the specific disease (D-). The false positive group (#FP) consists of the number of patients with an abnormal test (T+) and the absence of the specific disease (D-). The false negative group (#FN) consists of the number of patients with a negative test (T-) but with the disease (D+).

The terms sensitivity, specificity, predictive value, and accuracy have been used to describe the value of a test. Examples are given based on Table 11.2. Sensitivity is defined as the ratio of

Table 11.2.
2 × 2 Decision Matrix

	Hyperthyroid (D+)	Nonhyperthyroid (D-)	
Elevated T ₄ (T+)	67 (#TP)	10 #FP)	77 elevated test results
Nonelevated T ₄ (T-)	31 (#FN)	771 (#TN)	802 nonelevated test results
	98 total hyperthyroid patients	781 total nonhyperthyroid patients	879 total patients and total tests

patients with the disease and with abnormal test results (positive for the disease) to all the patients with the disease. Sensitivity = $\#TP / (\#TP + \#FN)$. This is the same as the conditional probability $P(T + | D +)$ or $67 / (67 + 31) = .68$. Sensitivity measures the ability to detect patients with the disease. This is also the true positive ratio (TPR).

The specificity of a test is defined as the ratio of normal test results in patients without disease to the total number of normal patients. Specificity = $\#TN / (\#TN + \#FP)$ or $771 / (771 + 10) = .99$. This is the same as the conditional probability $P(T - | D -)$. The false positive ratio (FPR) = $(\#FP) / (\#FP + \#TN) = 10 / (10 + 771) = .01$. Specificity = $(1 - FPR)$.

The predictive value of a positive test is the probability that a patient has the disease, given an abnormal test result, and is defined as $\#TP / (\#TP + \#FP)$ or $67 / (67 + 10) = .87$. The predictive value of a negative test is $\#TN / (\#TN + \#FN)$ or $771 / (771 + 31) = .96$.

Accuracy is defined as the fraction of total test results which are correct and is $(\#TP + \#TN) / (\#TP + \#TN + \#FP + \#FN)$ or $(67 + 771) / (67 + 771 + 10 + 31) = .95$. The likelihood ratio (L) is the ratio of the true positive ratio to the false positive ratio. $L = TPR / FPR$.

To create a 2 × 2 table requires a decision as to what test value divides normal from abnormal. If the test has a continuum of values,

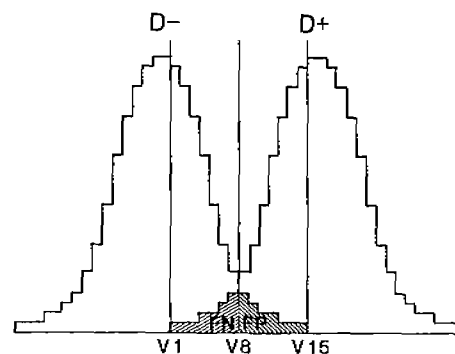

Figure 11.1. Distribution of test results from diseased (D+) and nondiseased (D-) patients, with little overlap of populations.

Table 11.3.
Sensitivity and Accuracy Values for Variable Thresholds

Threshold Point	Figure 11.1		Figure 11.2	
	Sensitivity	Accuracy	Sensitivity	Accuracy
1	1.00	.79	1.00	.56
2	1.00	.83	1.00	.59
3	.99	.87	.99	.63
4	.99	.91	.99	.63
5	.98	.93	.98	.70
6	.98	.94	.98	.74
7	.97	.95	.97	.78
8	.96	.96*	.95	.81
9	.94	.95	.94	.84
10	.90	.94	.91	.86
11	.84	.93	.87	.87*
12	.77	.91	.81	.86
13	.70	.87	.75	.84
14	.61	.83	.67	.81
15	.53	.79	.59	.78
16			.50	.74
17			.41	.70
18			.33	.66
19			.25	.63
20			.19	.59
21			.13	.53

* Crossing point.

various cutoff points can be identified in which sensitivity and specificity can be modified to minimize health costs, minimize incorrect results, or maximize the information content of the test (6-10).

Figure 11.1 is an idealized distribution of test results of diseased (D+) and nondiseased (D-) patients. There are equal numbers of patients in both groups, and each group is symmetrical about its mean. The overlapping zone of the two distributions produces 15 different thresholds (V), varying from V1 to V15, which could be chosen to separate normal from abnormal. The threshold, V8, at the crossing point, intuitively is the point where fewest incorrect classifications will be obtained. Calculation of sensitivity and accuracy for each of the 15 threshold points appears in Table 11.3. The maximum accuracy occurs at threshold V8 which is the crossing point. If the distribution were less clearly separated as in Figure 11.2, there would be greater overlap; nevertheless, the crossing point would

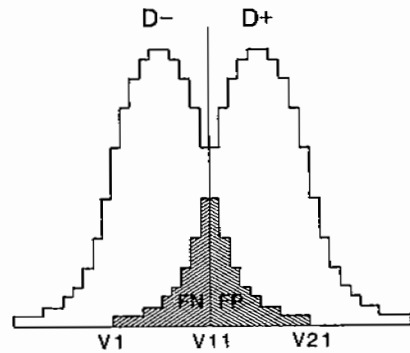

Figure 11.2. Less clear separation of symmetrical populations D+ and D-.

be the optimal threshold (6, 9). Now consider Figure 11.3 which is a modification of the thyroid data in Table 11.2. There are almost 8 times as many normals (D+) as abnormal (D-). In this asymmetrical and unequal distribution, the threshold defined by the crossing point again produces the greatest accuracy, as is shown in Table 11.4.

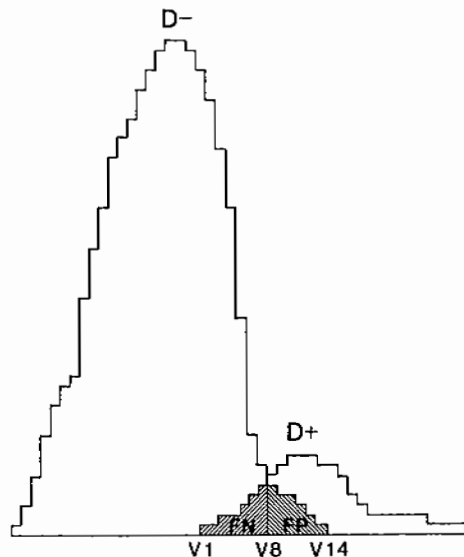

Figure 11.3. Modification of thyroid data from Table 11.2. D+ has almost 8 times the number of patients as D-.

In the real world, the selection of the threshold between normal and abnormal is often selected based on the relative seriousness of the consequences of misclassifying the patient. When the task is one of screening for a possibly fatal disease with a safe treatment, a high sensitivity is required. This means that almost all persons with the disease are identified but at the price of many false positive examinations. This would correspond to placing a threshold at V1, V2, or V3 in Figure 11.3. To determine the optimal cutoff point, we determine the true positive and false positive ratios at each point along the curve. A plot of these true positive to false positive ratios appears in Figure 11.4. This curve is known as a "ROC curve," an abbreviation for receiver operating characteristic curve (11, 12). At threshold (V1), all diseased patients are identified, but 28% of normal patients are falsely classified as abnormal. This is a highly sensitive threshold. At the crossing point (V8), 82% of diseased patients are identified and only 2% of normal patients are falsely classified as diseased.

Selection of the optimal cutoff point requires knowledge of the prior probability of diseased P(D+) and nondiseased P(D-) patients. The probability of hyperthyroidism is P(D+) = .11 and, for the absence of hyperthyroidism, is P(D-) = .89. When the slope of the ROC curve equals the ratio of P(D-)/P(D+), the maximum accuracy lies in that vicinity of the curve (Fig. 11.4).

The optimum threshold is also influenced by the ratio of the cost of a false positive (\$FP) diagnosis to the cost of a false negative diagnosis (\$FN). If the cost of a false negative diagnosis is high and the cost of a false positive diagnosis is low, the optimal threshold will shift up the curve to the region of greater sensitivity and less specificity. If, on the other hand, the cost of treating a normal patient for the disease is high, the optimal point will shift down the curve to the more vertical and left-most portions of the curve. In screening programs, this optimal threshold is the region of lower sensitivity and greater specificity. If the cost of a false positive (\$FP) result is twice that of the cost of a false negative (\$FN) result, the slope at the optimal threshold will be 16 (Fig. 11.4).

Table 11.4. Sensitivity TPR, Accuracy, FPR Changes with Threshold Valuation for Figure 11.3

Threshold Point	Sensitivity (TPR)	Accuracy	FPR
1	1.00	.75	.28
2	.99	.80	.22
3	.98	.85	.17
4	.96	.89	.12
5	.94	.93	.07
6	.91	.95	.05
7	.87	.96	.03
8*	.82	.96	.02
9	.76	.96	.02
10	.68	.95	.01
11	.60	.95	.01
12	.52	.94	.00
13	.44	.94	.00
14	.37	.93	.00
15	.26	.92	.00
16	.19	.91	.00
17	.15	.91	.00

* Crossing point.

Problems of utility, i.e., the relationship of false positive costs to false negative costs, are discussed by Hill (4), Behn and Vaupel (5), McNeil et al. (6, 9), Pauker and Kassirer (13), Bell (14), Gorry et al. (15), Thornbury et al. (16), Galen and Gambino (17), and Pauker and Pauker (18). Bell's article is especially clear, concise, and readable for those intimidated by mathematics. This area is quite difficult. The third-party payers, the physician, and the patient usually will be in disagreement as to the "best" outcome. Should money costs be minimized, or should life expectancy, health outcome at 10 years, years of gainful employment, or diagnostic efficacy be maximized?

BAYES' THEOREM

A diagnosis is often revised with the addition of new data. Consider the prior probabilities of hypothyroidism (P(D1) = .05), euthyroidism (P(D2) = .84, and hyperthyroidism (P(D3) =

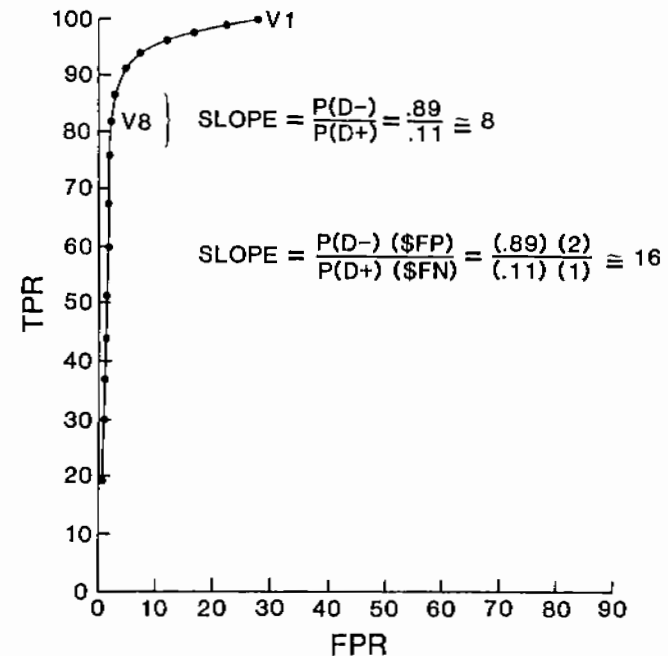

Figure 11.4. ROC curve from Figure 11.3. See text for explanation.

.11) obtained at the University of Kansas Division of Nuclear Medicine from 1975 through 1980. Can we improve our diagnostic classification over the prior probabilities of disease by the addition of laboratory test results from Tables 11.1 and 11.2? Bayes' theorem provides the method to revise the diagnostic probabilities based on the new data.

$$P(D+ | T+) = \frac{P(T+ | D+)P(D+)}{P(T+)}$$

$P(D+ | T+)$ is the probability of disease, given a positive test. $P(T+ | D+)$ is the probability of a positive test, given the presence of disease. $P(D+)$ is the probability of finding disease in the population, and $P(T+)$ is the probability of finding an abnormal test in the population.

For example, Bayes' theorem permits us to determine the probability of the presence of hypothyroidism, euthyroidism, and hyperthyroidism, given knowledge of an elevated T_4 .

In Table 11.2, there were 67 of 98 patients with an elevated T_4 and hyperthyroidism $P(T_4+ | D3) = 67/98 = .684$. Don't confuse numbers of tests or numbers of patients with probabilities. There were no elevated T_4 s in the (D1) group, i.e., $P(T_4+ | D1) = 0$. Ten euthyroid patients (D2) had elevated T_4 s, i.e., $P(T_4+ | D2) = .014$. The probability of an elevated T_4 in the entire population is

$$P(T_4+) = P(D1)P(T_4+ | D1) + P(D2)P(T_4+ | D2) + P(D3)P(T_4+ | D3)$$

$$P(T_4+) = (.05)(.00) + (.84)(.014) + (.11)(.684) = .087$$

$$P(D1 | T_4+) = (.00)(.05)/(.087) = 0$$

$$P(D2 | T_4+) = (.014)(.84)/(.087) = .14$$

$$P(D3 | T_4+) = (.684)(.11)/(.087) = .86$$

The probability of hypothyroidism, given an elevated T_4 , is 0.0. The probability of euthyroidism, given an elevated T_4 , is .14. The probability of hyperthyroidism, given an elevated T_4 , is .86. Given an elevated T_4 , the patient is more than 6 times as likely to be hyperthyroid as to be euthyroid. Bayes' theorem has revised the prior probabilities, based on finding an elevated T_4 .

For determination of the probability of hypothyroidism, euthyroidism, and hyperthyroidism, when both T_4 and T_3 RIAs are elevated, Bayes' theorem is expanded as in Figure 11.5. $P(D1 | T_4+, T_3RIA+)$ is the probability of hypothyroidism, given an elevated T_4 RIA and an elevated T_3 RIA. Note that the denominators are identical and are composed of the sum of all the numerators. The formula is long but is simple if broken into its components. When both T_4 and T_3 RIAs are elevated, the probability of hypothyroidism is 0, the probability of euthyroidism is .002, and the probability of hyperthyroidism is .998. With both tests elevated, the probability

$$P(D1 | T_4+, T_3RIA+) = \frac{P(D1)P(T_4+ | D1)P(T_3RIA+ | D1)}{P(D1)P(T_4+ | D1)P(T_3RIA+ | D1) + P(D2)P(T_4+ | D2)P(T_3RIA+ | D2) + P(D3)P(T_4+ | D3)P(T_3RIA+ | D3)}$$

$$P(D2 | T_4+, T_3RIA+) = \frac{P(D2)P(T_4+ | D2)P(T_3RIA+ | D2)}{P(D1)P(T_4+ | D1)P(T_3RIA+ | D1) + P(D2)P(T_4+ | D2)P(T_3RIA+ | D2) + P(D3)P(T_4+ | D3)P(T_3RIA+ | D3)}$$

$$P(D3 | T_4+, T_3RIA+) = \frac{P(D3)P(T_4+ | D3)P(T_3RIA+ | D3)}{P(D1)P(T_4+ | D1)P(T_3RIA+ | D1) + P(D2)P(T_4+ | D2)P(T_3RIA+ | D2) + P(D3)P(T_4+ | D3)P(T_3RIA+ | D3)}$$

$$P(D1 | T_4+, T_3RIA+) = \frac{(.05)(.00)(.051)}{(.05)(.00)(.051) + (.84)(.014)(.012) + (.11)(.684)(.869)} = .000$$

$$P(D2 | T_4+, T_3RIA+) = \frac{(.84)(.014)(.012)}{(.05)(.00)(.051) + (.84)(.014)(.012) + (.11)(.684)(.869)} = .002$$

$$P(D3 | T_4+, T_3RIA+) = \frac{(.11)(.684)(.869)}{(.05)(.00)(.051) + (.84)(.014)(.012) + (.11)(.684)(.869)} = .998$$

Figure 11.5. Bayes' theorem expanded to include results of an elevated T_4 RIA and an elevated T_3 RIA. In this figure, T_3 RIA is labeled as such to distinguish it from the T_3 resin uptake test.

of hyperthyroidism is 499 times that of euthyroidism $[(.998/.002) = 499]$. It is, nevertheless, a probabilistic diagnosis which, in theory, cannot give total diagnostic assurance of $P = 1.00$.

It is possible to rank each test and each unique group of test results to obtain the combination of tests which yields the highest probability for identifying each disease. From Table 11.1, there are 5 tests for each disease state, and there are 3 states for each test. There are $243 = 3^5$ possible combinations. Many of the combinations will be quite unusual. The combination of low T_4 , low T_3 resin, low T_3 RIA, high effective thyroid ratio (ETR), and high 24-hour ^{131}I uptake would be unusual. Except for the high ETR, the test results might indicate the recovery phase of subacute thyroiditis. Hundreds of thousands of studies would have to be analyzed before the rare combinations had adequate numbers for meaningful analysis. Overall and Williams (19) obtained useful results from less than 900 patients by using the more frequently occurring combinations. In later work (20, 21), their accuracy in classifying patients was between that of a general internist and an endocrinologist specializing in thyroid disease. What is important is their use of the inexpensive history and physical examination as the modality for achieving impressive diagnostic results.

The probability of correct classification is influenced to some extent by the prior probability of disease. In our institution, between 1976 and 1980, $P(D1) = .05$, $P(D2) = .84$, and $P(D3) = .11$. In the Division of Nuclear Medicine at the University of Florida, Gainesville, from 1958 to 1967, prior probabilities varied from $P(D1) = (.04 \text{ to } .06)$, $P(D2) = (.79 \text{ to } .87)$, $P(D3) = (.10 \text{ to } .15)$, depending on the patient population and method of determination (22). These figures are essentially identical to those at the University of Kansas, even though they are separated by 20 years and 1000 miles.

Suppose the prior probabilities were $P(D1) = .33$, $P(D2) = .33$, and $P(D3) = .33$. Calculate the probabilities of disease, using these prior probabilities, and compare these results

with the previous results by utilizing the elevated T_4 data from Table 11.1.

$$P(D | T_4+) = P(D)P(T_4+ | D)/P(T_4+)$$

$$P(T_4+) = (.33)(.00) + (.33)(.014) + (.33)(.684) = .23$$

$$P(D1 | T_4+) = (.33)(.00)/(.23) = 0$$

$$P(D2 | T_4+) = (.33)(.014)/(.23) = .02$$

$$P(D3 | T_4+) = (.33)(.684)/(.23) = .98$$

Previous calculation produced $P(D1 | T_4+) = 0$, $P(D2 | T_4+) = .14$, and $P(D3 | T_4+) = .86$.

Comparison of $P(D | T_4+)$, with use of arbitrary prior probabilities, shows a definite change from the Kansas and Florida results. This change indicates that prior probabilities can influence probability of disease calculations, but as we have shown with use of real data, different institutions may have similar prior probabilities.

DECISION ANALYSIS

Optimal therapy is the successful conclusion of diagnosis. The path from problem identification to diagnosis and through therapy is complex, with conflicting perceptions, opinions, images, tests, risks, probabilities, patient values, physician values, and third-party payer values. Decision analysis (5, 23) permits an orderly approach to these problems and has been successfully applied to numerous complex real world medical problems. All reasonable variations of the diagnostic pathway can be explicitly outlined, clinical decisions identified, probabilistic and value judgments considered, and an optimal course of events identified.

The decision tree (Fig. 11.6) is a graphic method that can demonstrate the logical sequence of diagnosis including test results, complications of tests, the effect of treatment, the effect of withholding treatment, and the ranking of final outcomes so that the pathway with greatest utility may be identified. By convention, the initial problem appears on the left and subsequent actions flow to the right. Decisions under the physician's control are represented by squares (decision nodes), and events not under a decision makers control (chance nodes) are rep-

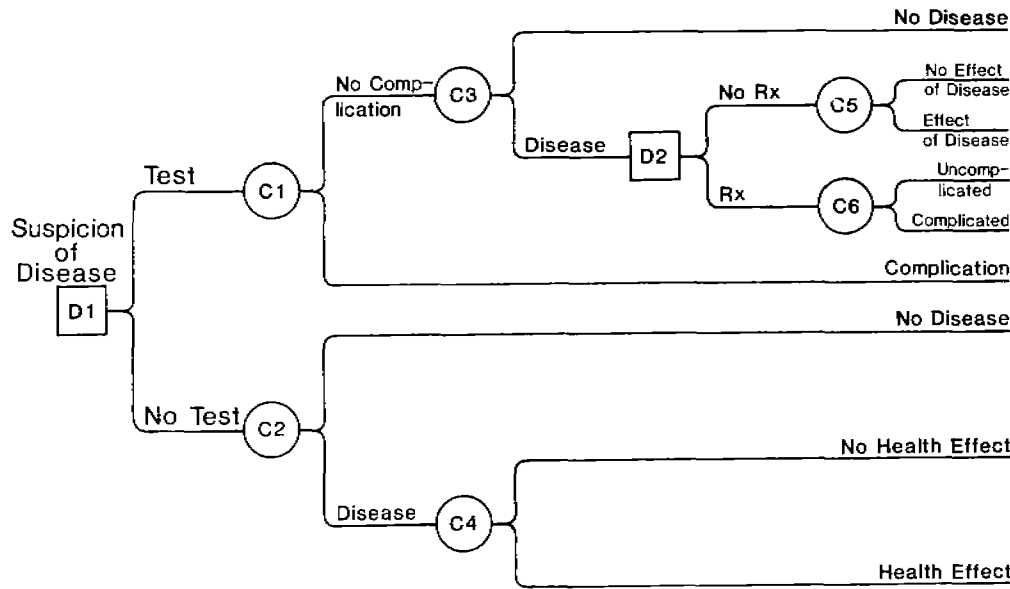

Figure 11.6. Decision tree.

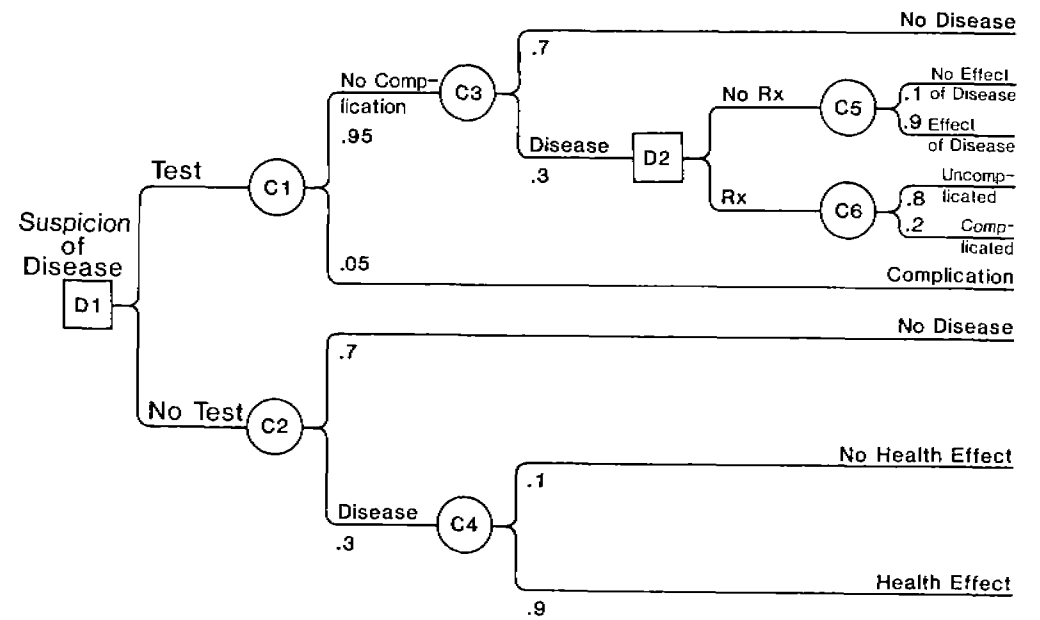

Figure 11.7. Decision tree with probabilities of disease, complications of test, complications of therapy, and outcomes added.

resented by circles. Final outcomes appear at the far right. In Figure 11.6, the suspicion of disease results in a decision (D1) to perform a test or to perform no test. The test may have complications (C1) which result in a deleterious health effect. In the absence of complications, the results of the test may exclude disease (C2), in which case there are no deleterious health effects but only the cost of the test. The test may identify disease, in which case a square decision node (D2) is encountered, at which time a decision to treat or not to treat the patient must be made. Treatment may be complicated or uncomplicated. The branching and multiplication of possibilities may become unwieldy. Note that in Figure 11.6 there are some simplifications already made but that the major pathways are described.

Simplification is a must, especially in complex business problems (5). The sheer complexity of the exhaustive complete decision tree will inhibit understanding and analysis. Sisson (24) and Pauker and Kassirer (13) use well-done and complex decision trees that are minimally simplified.

The probability of disease (.3), complications of the test (.05), and complications of therapy (.2) are then added as in Figure 11.7. The utilities or value of each outcome must then be estimated. The best, worst, and intermediate outcomes must be determined and ranked. The physician will ordinarily use the patient's values, at least as they are understood. Pauker and Pauker (18) show the usefulness of questionnaires to elicit patient values. Pauker and Kassirer (13), in their example concerning pulmonary embolism, utilize a more complex method of estimating utilities that is based on life expectancy and expected time free of morbidity, while Sisson et al. (24) estimate the remaining years of life expected. In Figure 11.8, the utility values are empiric estimations. The worst outcome is a complication of the test (death), while the best outcome is to do no test and have no disease.

The next step is to calculate the expected utility at each node. Expected utilities are in ovals close to the appropriate node (Figure 11.9). Reading from the right of Figure 11.9, the sum of the products of the utility and proba-

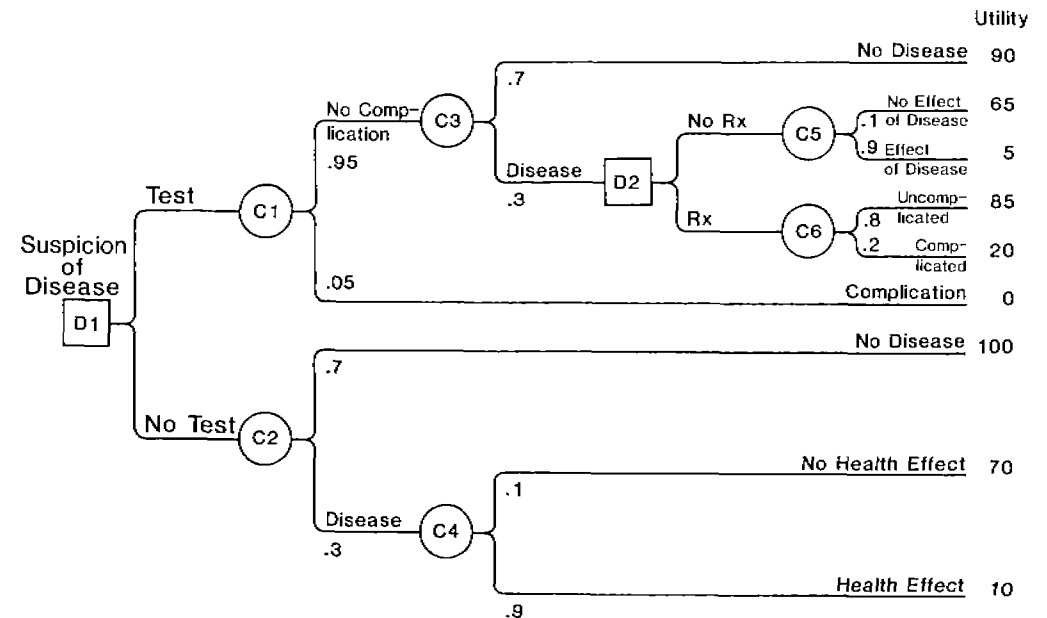

Figure 11.8. Decision tree with empiric utilities added.

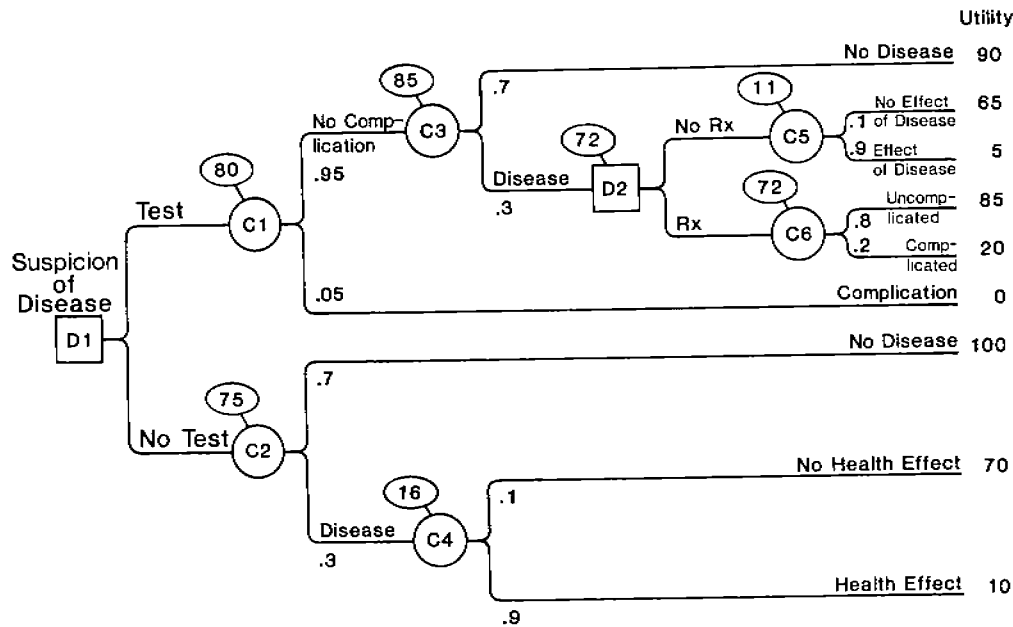

Figure 11.9. Decision tree with expected utilities calculated for each node.

bility of each branch is the utility value of the chance node to the left. At decision nodes, the utility of the branch with the highest value is assigned to the decision node.

The expected utility at

$$\begin{aligned}
 C5 &= 11 [(65 \times .1) + (5 \times .9)], \\
 C6 &= 72 [(85 \times .8) + (20 \times .2)], \\
 D2 &= 72, \\
 C3 &= 85 [(72 \times .3) + (90 \times .7)], \\
 C1 &= 80 [(85 \times .95) + (0 \times .05)], \\
 C4 &= 16 [(70 \times .1) + (10 \times .9)], \\
 C2 &= 75 [(100 \times .7) + (16 \times .3)].
 \end{aligned}$$

At node D2, the physician should treat the patient, since that is the pathway of greatest utility. At D1, the physician should follow the pathway of greatest utility and perform the test. These are reasonable decisions based on .3 prior probability of disease. Suppose the prior probability of disease is .5 or .7. There will be numerical changes in expected utility values, but will there be a change in the decision to test?

SENSITIVITY ANALYSIS

Sensitivity analysis (5, 13) permits an answer to this question by relating the expected utility (in arbitrary units) to the prior probability of disease. If in Figure 11.9 the prior probability of disease were .00, the utility of testing (C1) would be 86, while the utility of not testing (C2) would be 100. In the example, when the prior probability of disease is .3, C1 = 80 and C2 = 75. When the probability of disease is 1.00, C1 = 68 and C2 = 16. These changes are plotted in Figure 11.10. When P(D) = 0, the greatest utility is to not test. When P(D) = 1.0, the greatest utility is to test. The point of equal utility between testing and not testing is P(D) = .23. Given the initial data of complication rate of the test, the effect of disease, and the complication rate of the treatment, the prior probabilities may range from .23 to 1.0, a fourfold range, and throughout that range the decision to test remains the one with highest utility value.

From P(D) = 0 to P(D) = .23, the decision to not test is superior.

Sensitivity analysis can define a threshold above which one action is optimum and below which another action is optimum.

SUMMARY

An organized, logical, and probabilistic approach to medical management is not new. The recognition that health care resources are finite is not new. The concerted effort to limit medical expenditures, already accepted by the medical community, is new. The current reimbursement plan is most likely just the beginning of enforced attempts to control expenditures while quality health care is maintained. Nuclear medicine must now show its cost-effectiveness to third-party payers, hospital administrators, patients, and referring physicians. This task will not be easy. It must start with our own education, with our willingness to work at quality assurance, data base acquisition, and techniques

of medical decision making, and with education of the referring physician.

In the past 6 years, the Society for Medical Decision Making has been formed. It is a multidisciplinary group composed of scientists, physicians, administrators, and educators who work toward the development and application of techniques to optimize diagnostic and therapeutic medical decisions. For example, the value judgments of medicine have been reinvestigated with the development of techniques that can aid in synthesizing values related to health, money (25), and malpractice. The discipline is in a developmental stage. We in nuclear medicine must learn to speak this mathematical and logical language in order to establish the value of the functional and physiological capabilities of nuclear medicine unique to patient care. We must demonstrate to all the value of identifying and treating specific functional abnormalities prior to the development of anatomical abnormalities. The costs of diagnosis by various

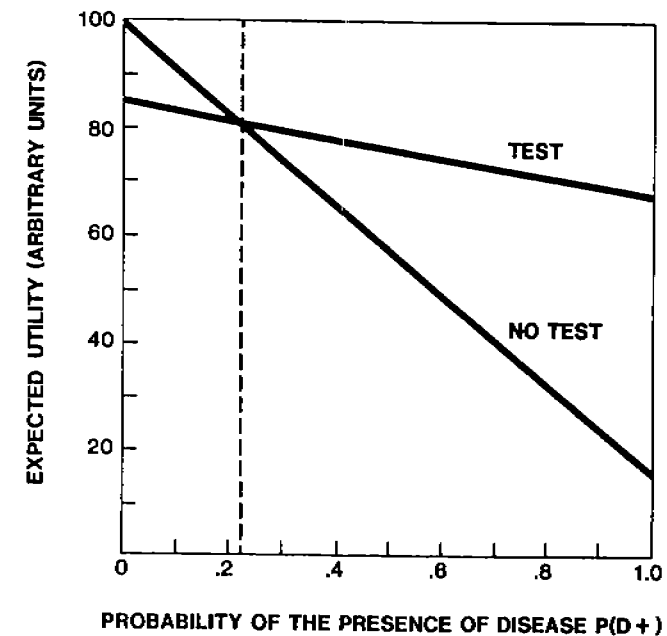

Figure 11.10. Sensitivity analysis graph. P(D) = .23 is the threshold below which the greater utility is associated with not testing and above which the greater utility is associated with testing.

modalities must be measured. The costs of missing the diagnosis must also be measured. The problems are complex, but progress is possible by using techniques of medical decision making.

REFERENCES

- Lusted LB: *Introduction to Medical Decision Making*. Springfield, IL, Charles C Thomas, 1968, pp 4-5.
- Edwards W, Lindman H, Savage LJ: Bayesian statistical inference for psychological research. *Psychol Rev* 70:193-242, 1963.
- Kotz S, Stroup DF: *Educated Guessing*. New York, Marcel Dekker, 1983, pp 21-22.
- Hill PH, Bedau HA, Chechile RA, et al: *Making Decisions*. Reading, MA, Addison-Wesley, 1979, pp 138-139.
- Behn R, Vaupel JW: *Quick Analysis for Busy Decision Makers*. New York, Basic Books, 1982, pp 78-100.
- McNeil BJ, Keeler E, Adelstein SJ: Primer on certain elements of medical decision making. *N Engl J Med* 293:211-215, 1975.
- Barnoon S, Wolfe H: *Measuring the Effectiveness of Medical Decisions*. Springfield, IL, Charles C Thomas, 1972.
- Patton DD: Introduction to clinical decision making. *Semin Nucl Med* 8:273-282, 1978.
- McNeil BJ, Adelstein SJ: Determining the value of diagnostic and screening tests. *J Nucl Med* 17:439-448, 1976.
- Griner PF, Mayewski RJ, Mushlin AL, Greenland P: Selection and interpretation of diagnostic tests and procedures. *Ann Intern Med* 94:553-592, 1981.
- Green DM, Swets JA: *Signal Detection Theory and Psychophysics* (revised). Huntington, NY, Krieger, 1974.
- Swets JA: The relative operating characteristic in psychology. *Science* 182:990-1000, 1973.
- Pauker SG, Kassirer JP: Clinical application of decision analysis: a detailed illustration. *Semin Nucl Med* 8:324-335, 1978.
- Bell RS: Efficacy . . . What's that?? *Semin Nucl Med* 8:316-323, 1978.
- Gorry GA, Pauker SG, Schwartz WG: The diagnostic importance of the normal finding. *N Engl J Med* 298:486-489, 1978.
- Thornbury JR, Fryback DG, Edwards W: Likelihood ratios as a measure of the diagnostic usefulness of excretory urogram information. *Radiology* 115:561-565, 1975.
- Galen RS, Gambino SR: *Beyond Normality: The Predictive Value and Efficiency of Medical Diagnosis*. New York, Wiley, 1975.
- Pauker SP, Pauker SG: Prenatal diagnosis: a directive approach to genetic counseling using decision analysis. *Yale J Biol Med* 50:275-289, 1977.
- Overall JE, Williams CM: Conditional probability program for diagnosis of thyroid function. *JAMA* 83:95-313, 1963.
- Fitzgerald LT, Williams CM: *Computer Diagnosis of Thyroid Disease*. Gainesville, FL, Department of Radiology, University of Florida College of Medicine, 1964.
- Fitzgerald LT, Overall JE, Williams CM: A computer program for diagnosis of thyroid disease. *Am J Roentgenol* 97:901-905, 1966.
- Bender CE, Fitzgerald LT, Williams CM: Probability values for protein bound iodine, thyroid I131 uptakes and T3 resin uptakes for hypothyroidism, euthyroidism and hyperthyroidism. *Am J Roentgenol* 103:886-894, 1968.
- Raiffa H: *Decision Analysis*. Reading, MA, Addison-Wesley, 1968.
- Sisson JC, Bartold SP, Bartold SL: The dilemma of the solitary thyroid nodule: resolution through decision analysis. *Semin Nucl Med* 8:59-72, 1978.
- Thompson MS: Health versus money: value judgments in the perspective of decision analysis. *Med Decis Making* 3:295-298, 1983.

12

Computer Applications in Nuclear Medicine

Jack L. Lancaster, John C. Lasher, and Ralph Blumhardt

Digital computers were introduced to nuclear medicine research as an imaging modality in the mid-1960s. Widespread use of imaging computers (scintigraphic computers) was not seen in nuclear medicine clinics until the mid-1970s. For the user, the ability to acquire scintigraphic images into the computer for quantitative purposes, with accurate selection of regions of interest (ROIs), promised almost endless computational capabilities. Investigators quickly developed many new methods for quantitating the distribution patterns of radiopharmaceuticals within the body both spatially and temporally (1-3). The computer was used to acquire data on practically every organ that could be imaged by means of gamma cameras or rectilinear scanners. Methods of image processing borrowed from other disciplines were applied to scintigraphic computer images in an attempt to improve image quality (4). Image processing in nuclear medicine has evolved into a relatively extensive set of tasks that can be called on by the user to provide additional clinical information rather than to improve image quality.

Digital computers are utilized in nuclear medicine departments for nonimaging applications also. Patient scheduling, archiving, radiopharmaceutical inventory, radioimmunoassay (RIA), and health physics are just a few of the areas in which the digital computer has proven helpful. The computer is useful in any area in which a large quantity of data needs to be accurately managed, especially over a long period of time.

Since the mid-1960s, the digital computer has evolved to the point where desk-top micro-computers are now more powerful than early systems used for imaging. The power of a com-

puter system lies in the combination of hardware and software. To utilize this power, a user generally needs to become knowledgeable about the capabilities as well as the limitations of the hardware and software. Software developed for general purpose use (such as word processors, database managers, and spreadsheets) often has tutorials included to provide training and practice such that users can become proficient quickly. Computer users need to be educated in computer basics as well as in the proper operation of software. Without both levels of training, users will not be able to reap the maximum benefits from their computer system. Users should keep up with newer and better versions of software to make optimum use of their hardware.

COMPUTER BASICS

The basic elements of a computer system are illustrated in Figure 12.1. Of primary interest to nuclear medicine users are the input and output (I/O) capabilities of the system, since a majority of the time that the user spends at the computer is dedicated to these tasks. This is true whether the computer is used to acquire images and/or textual data. Once the data are acquired by the computer and depending on the desired output, various forms of processing may be performed. The overall purpose of a computer system is to acquire data, process data, and provide the desired output.

The inputs to a digital computer include analog voltages from imaging devices, data in digital format, and keyboard entry (Fig. 12.1). For scintigraphic computer systems commonly utilized in nuclear medicine, the inputs are generally "x" and "y" positional signals, isotope

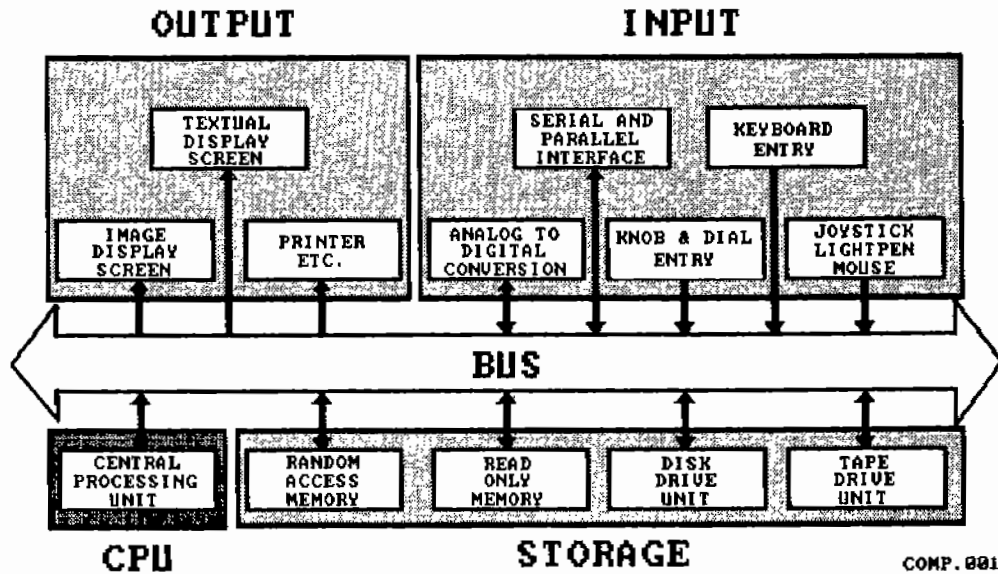

Figure 12.1. Block diagram of computer system illustrates the input, output, storage, and CPU components commonly connected by the system bus.

unblank signals (indicating that x and y signals are due to the correct energy), and multiple physiologic signals (Fig. 12.2). These signals pass through operational amplifiers which condition their gains and thereby provide voltages acceptable to the computer circuits. Within the computer system, analog-to-digital converters (ADCs) transform the analog voltages to digital numerical values for binary storage and subsequent use by the computer. During acquisition of gamma camera images, the input can be in the form of a "list" mode or a "frame" mode. With list mode acquisition, digitized positional information from the ADCs, timing marks from a real-time clock, and other data, such as physiological triggers, can be stored in the order of receipt as a form of high-speed recording of gamma camera data (Fig. 12.3). List mode data can then be reformatted into images, with selection of various parameters such as time and/or image, isotope A or B, and physiological gating. The most common mode of acquisition of gamma camera images is the "frame" mode in which the data are sorted into a frame such that addresses in the frame array correspond to x and

y coordinates from the gamma camera field of view (Fig. 12.4). This mode of acquisition furnishes instant images for storage and display (no reformatting as for list mode). In frame mode acquisition, the x and y coordinate data are sorted into arrays of 32 x 32, 64 x 64, 128 x 128, 256 x 256, or 512 x 512 elements. The elements are referred to as "pixels," meaning picture elements. Most nuclear medicine frame mode acquisition utilizes 64 x 64 to 128 x 128 pixel images. Additionally, the mode of acquisition is commonly referred to as byte mode or word mode indicating how many counts can be stored at a pixel. Byte mode images allow a range of from 0 to 255 counts/pixel, while word mode images allow from 0 to 65535 counts/pixel. There is some variability in the range of counts which can be stored in pixels for various computers. A 64 x 64 byte mode image requires a total of 4096 bytes (4K byte) of memory for storage. The storage requirements and common uses for various modes of acquisition are given in Table 12.1.

The keyboard is the most common method of operator input to a scintigraphic computer. Ad-

ditionally, input is available through hardware devices such as joysticks, light pens, track balls, and "mice." These devices can provide interaction with either a menu or image data.

Use of the keyboard is required for input of alphanumeric information. Patient data, study data, operator name, and the date and time are common examples of this type of information. Some microcomputers have a touch screen menu selection, while others require a keyboard output and connect with the computer through a serial or parallel digital interface (Fig. 12.1). All analog input devices require an ADC to transform the input analog voltages to discrete

digital values acceptable to the computer (Fig. 12.1). Additionally, each I/O device has to be supported by software (commonly called device drivers) such that data are passed to the computer in a meaningful fashion.

There are many possible output devices used with computers. In nuclear medicine, the most common output devices include a display screen for text, a printer screen for images and graphics, and a printer. The display screen for text should provide a text font (dot pattern to produce text characters) which is easy to read. Additionally, it is desirable for the text display to have attributes such as reverse video and blinking, to help prompt the operator for input. A printer should produce roughly 40 words/minute and may be either a dot matrix or a daisy wheel type. If the printer is a dot matrix type and is utilized with microcomputers having

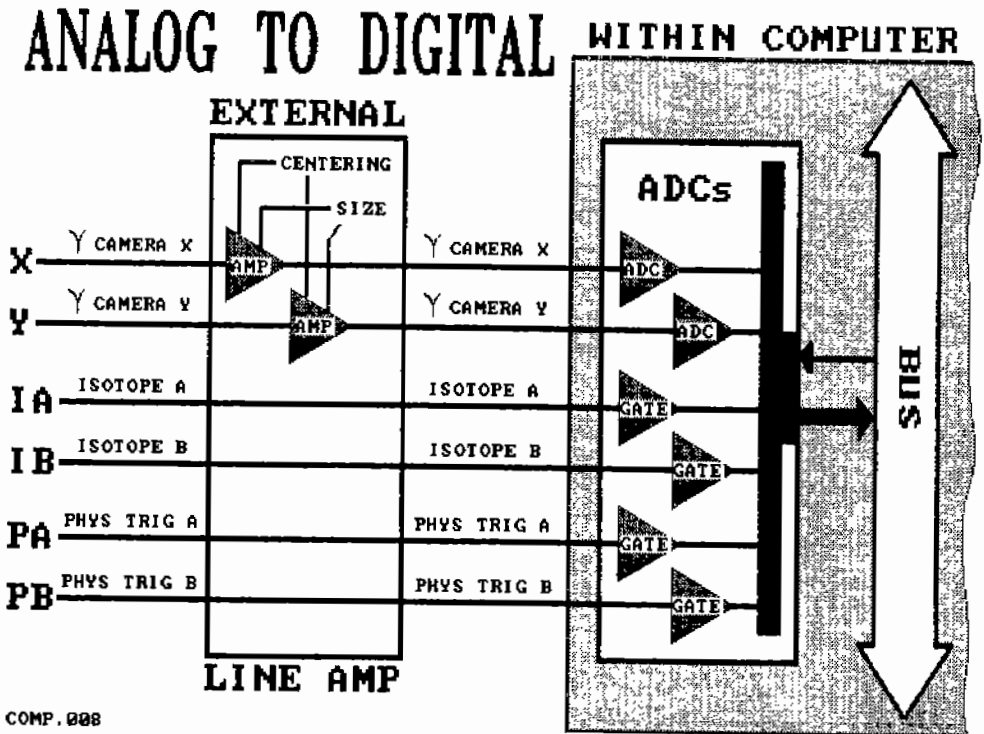

Figure 12.2. Block diagram of ADC and line amplifier used to interface the analog signals from gamma cameras and physiological monitors to the computer. The line amp provides for adjustment of the x and y gamma camera coordinate signals to provide image size and centering of the signals forwarded to the ADCs.

pass data from one location to another (see Fig. 12.1). The bus contains a number of electrical lines sufficient for addressing (16–20 bits or lines), for data transfer (8–16 bits or lines), for control signals (variable with CPU), and for electrical power (variable with CPU) to support devices connected to it. The CPU has access to a large quantity of random access memory (RAM) for use in storing data and programs. The CPU also has access to read only memory (ROM) which contains a set of programs and/or data that cannot be altered and that remain intact when the computer power is turned off. The CPU has a limited vocabulary with regard to the actions that it can perform. This vocabulary is referred to as the instruction set for the CPU or microprocessor. A computer program is a sequence of commands from this instruction set, with data inserted where appropriate. A program can be stored in ROM to provide the computer with the capability to read a keyboard, to display on a screen, to load files from disk, to execute other programs, and to perform many other menial tasks. A collection of computer programs for a common purpose is called "software." The software stored in ROM is sometimes referred to as a "monitor" or a "command interpreter." This software allows the user to load and execute other programs that are stored on disks. It would be impossible to have all the programs necessary in clinical nuclear medicine reside in the computer memory at the same time; therefore, most of the programs called into use are read from disk. The process of loading and executing a program initially entails the transfer of the program from a disk to RAM. Once the program is in RAM, the CPU is informed of the location, and the CPU proceeds to interpret and execute the sequence of instructions that comprise the program. A system of operation in which part of the system software (i.e., the monitor) remains in RAM, but most system programs are loaded from disk and executed when desired, is called a disk operating system (DOS).

When the computer is first turned on, a program in ROM is automatically executed. This program may load another program, such as the main menu, into RAM and start that program running. The main menu program is used to

allow users to select which programs to execute in order to perform the desired tasks, such as acquire an image, display an image, select a ROI, and generate a curve. In older computers, the system was started by "booting" the monitor program from disk. The booting procedure involved setting some switches on the computer and manually starting the computer by executing a small ROM program. The small ROM program, when executed, would load a larger program from a specific location on a specific disk drive and start execution of that program. The program loaded was usually the monitor.

System software is intended to provide smooth operation of the hardware associated with a computer system as well as many utilities to allow for development and management of higher levels of software. Clinical software is commonly developed in computer languages such as FORTRAN, BASIC, and C. These high-level software development languages have to be supported by specialized libraries to perform tasks associated with hardware specific to a particular computer system. Clinical software is distinguished from system software in that it utilizes the computer system to perform some clinical task. Generally, clinical software is categorized as to general purpose, whether that be acquisition, processing, or display. The quantity and quality of clinical software is a major factor in selection of a computer system.

CLINICAL USES FOR SCINTIGRAPHIC COMPUTERS

The most successful clinical application of the scintigraphic computer has been in the area of nuclear cardiology (5). This application clearly justifies the use of computers in nuclear medicine, since in most cases it would not be possible to acquire and process these clinically important studies without them.

Noninvasive methods of assessing cardiac function are greatly needed, since clinical questions frequently arise about cardiac performance under varying conditions of rest, exercise, and pharmacological therapy. With the possible exception of echocardiography, these questions cannot be answered without resorting to more invasive procedures, such as contrast angiography.

Gated Ventriculography

One of the most frequently requested parameters of cardiac performance is the ejection fraction (EF) of the left ventricle. The EF is the amount of volume ejected from the heart (stroke volume (SV)), divided by its initial resting volume (end diastolic (ED) volume). The SV can be determined by subtracting the minimum volume during contraction (end systolic (ES) volume) from the ED volume. In the early 1970s, the EF was calculated primitively by use of an electronic gating device that allowed the separate acquisition of ED and ES images of the blood pool within the heart chambers. The relative ventricular long- and short-axes changes were measured between ED and ES and used to determine the EF. This method is exactly analogous to the present methods used in single-plane contrast ventriculography, including all of its associated geometrical errors.

In 1977, Bacharach and Green (6) introduced a method for acquiring gated cardiac blood pool

images. This form of acquisition was unique to the computer in that images were acquired relative to the onset of cardiac contraction rather than for preset counts or time as with a gamma camera only. Typically, 16–32 separate images were acquired, with each image representing different time intervals within the cardiac cycle (Fig. 12.5.) Geometrical assumptions for the EF calculations were not used; instead, the very powerful and unique scintigraphic assumption that counts are directly proportional to volume was the underlying basis for the EF calculations.

Presently, this procedure typically is accomplished by injecting the patient intravenously with a small amount of nonradioactive stannous pyrophosphate. After a proper amount of time (approximately 20 minutes), 15–30 mCi of [^{99m}Tc]pertechnetate is injected intravenously, which results in the radiolabeling of the red blood cells within the intravascular compartment (blood pool). Gated cardiac blood pool



Figure 12.5. Sixteen-image gated blood pool study taken from a 24-frame MUGA study. The images were acquired in a LAO projection from a normal patient. The ED image is in frame 1, and the ES image is in frame 10.

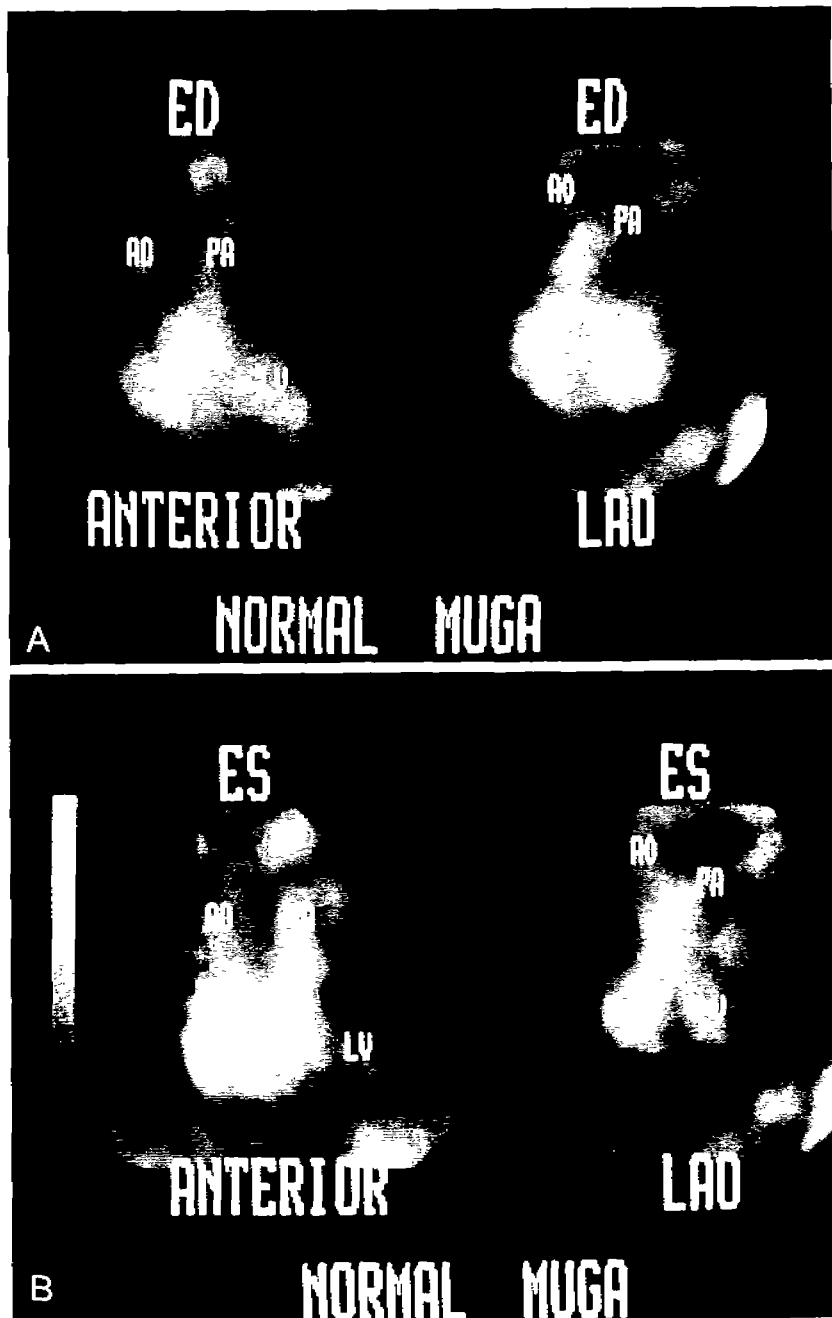

Figure 12.6. ANT and LAO gated blood pool views (A, ED views; B, ES views) taken from the same normal patient as in Figure 12.5. The following abbreviations are used: AO, aorta; LV, left ventricle; PA, pulmonary artery; RV, right ventricle.

images are then obtained in the anterior (ANT) and left anterior oblique (LAO) projections (Fig. 12.6). The patient can either be at rest or at exercise equilibrium.

The computer is required to correctly synchronize the collection of data with the onset of cardiac contraction (Fig. 12.7). The electrocardiogram (EKG) "R-wave" is an acceptable reference of the beginning of cardiac contraction and can be sensed electronically and sent to the computer as a timing reference or "trigger." Two or more triggers are used by the computer to determine the period of time between heart cycles. This period is divided by the desired number of gated images or memory frames to find the time interval to allocate to each frame (approximately 20–100 msec). For the first interval of time following a trigger, all of the gamma camera data sent to the computer are stored in the first frame. Subsequent intervals of time within the first cardiac cycle have frames of

acquired data that picture the heart in various stages of contraction and relaxation. The next R-wave signals the computer to start over in the first frame of memory. It is this "multiple-gated" process that results in a series of frames that are representative of an average heart beat. This method often is called MUGA (multiple-gated acquisition) which is a trademark of the Medical Data Systems (MDS) Corporation.

The averaging process required to obtain statistically significant images brings some disadvantages to the technique. Patients must possess an unvarying heart rate in order to generate R-wave triggers separated by a constant period. If the heart rate is allowed to vary, the frames will not represent discrete segments of the cardiac cycle; instead, an averaged picture of many different heart cycles results. A minimum acquisition time of 2 minutes is required to produce clinically useful frames, and when possible, acquisition of up to 10–20 minutes is obtained.

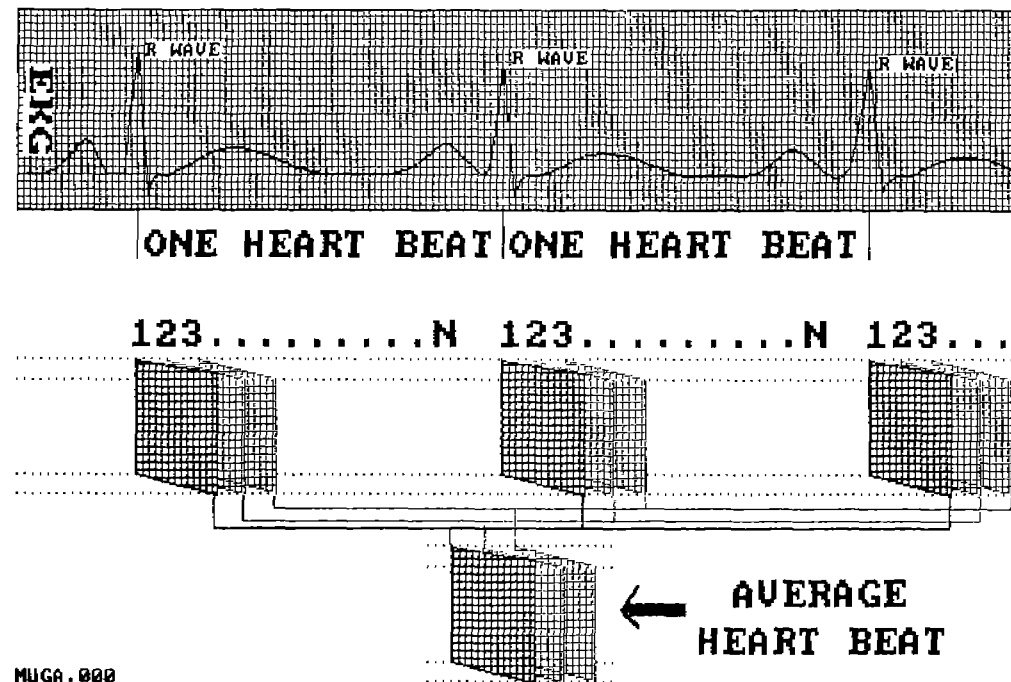

Figure 12.7. Multiple-gated acquisition illustrates the development of a single set of images representing the average heart beat.

This minimum amount of time (2 minutes) prevents the instantaneous determination of cardiac function. Cardiac wall motion, obtained by viewing the frames in rapid sequence as an endless loop (cine), results in the repetitious viewing of a single average heart cycle.

The motion of the cardiac chambers from various views can help assess the extent and degree of cardiac disease, especially myocardial ischemia or infarction resulting from coronary artery disease (7). The left ventricular EF (LVEF) is an important index of cardiac function, particularly the exercise function of the heart, since it falls with progressive increases of exercise in the presence of clinically significant coronary artery disease.

The LVEF is calculated by identifying to the computer which region of the image represents the left ventricle during the ED and ES images (Fig. 12.8). After appropriate correction for activity not emanating from the left ventricle (i.e., background subtraction) (8), the EF is calculated by a simple subtraction of ED counts from ES counts, the result of which is divided by ED counts. Typically, the LV region of the image is marked in each of the frames, which allows the computer to generate a LV volume curve. From this curve, LV filling and emptying rates can be obtained and used as a sensitive indicator of LV dysfunction. Additionally, the left ventricle can be further subdivided into regions, which allows discrete segments to be analyzed for localized disease.

The absolute volume of the left ventricle can be determined by use of various methods that solve for the correction factor that relates LV counts to volume (9). From this determination, cardiac output can be determined, since the heart rate is known. An ejection image formed from the subtraction of the ED image from the ES image can provide additional information concerning the symmetry of wall motion. A paradox image formed from the subtraction of the ED image from the ES image provides information concerning paradoxical wall motion found in ventricular aneurysms and severe myocardial ischemia.

Since the contraction of the heart is a recurrent event, it can be analyzed by Fourier principles by which the time-activity curve for each pixel in the image series is fitted to a fundamen-

tal frequency determined from the heart rate (10). This method has aroused considerable interest, since it promises to be advantageous in detection of subtle areas of abnormal wall motion and helpful in work with patients with intracardiac conduction disturbances. The data typically are displayed as "functional images" representing the amplitude and phase of fundamental cardiac motion on a pixel-by-pixel basis. Pseudocolor displays commonly are used for displaying these functional images.

In summary, the motion of the heart wall can be inferred from watching a cine presentation of the MUGA study. Additionally, various investigators have shown good correlation between the determination of EF and ventricular volumes with determinations from catheterization laboratory data (9, 11). A major advantage of the MUGA study is that it is much less traumatic than cardiac catheterization, yet provides information concerning wall motion, EF, and ventricular volumes.

Myocardial Perfusion

The early diagnosis of coronary artery disease (CAD) is of major therapeutic concern. CAD affects more than half of the population of the western world and accounts for approximately one third of all causes of death. The exercise tolerance test (ETT) has been the primary test for CAD, but poor sensitivity and specificity (ranging from 70% to 80%) have been reported in many patients suspected of having CAD. In particular, the ETT is poor in patients (a) with atypical chest pain, (b) with an uninterpretable EKG, (c) with equivocal EKG changes, and (d) who are receiving certain cardiac medications. It is with these patients that myocardial perfusion imaging is most useful. The injection of ^{201}Tl thallous chloride intravenously at peak ETT stress, followed by gamma camera imaging, has resulted in a marked increase in the sensitivity and specificity for diagnosing CAD (12).

Initially, the ^{201}Tl study was performed without a computer by acquiring "planar" images directly from the gamma camera onto film. The patient underwent a standard ETT during which, at near peak exercise, he was given an intravenous injection of 1.5–3.0 mCi of ^{201}Tl . The exercise was continued for an additional

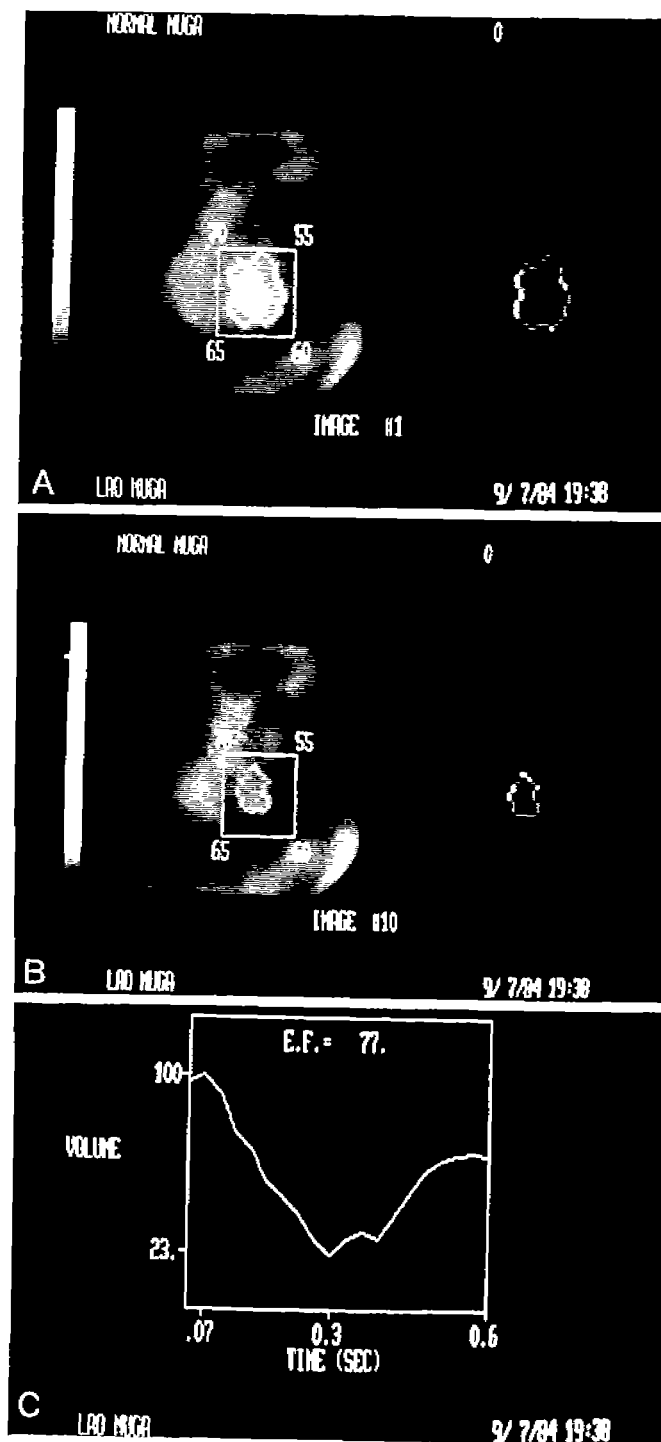

Figure 12.8. LAO gated blood pool images taken from the same normal patient as in Figure 12.5. This figure illustrates a semiautomatic ROI selection process used in developing the volume curve and calculating the EF

30–60 seconds, and within 10 minutes following injection, the patient was moved to the gamma camera. Imaging was performed in several projections, although usually in ANT,

LAO, and lateral (LAT) projections (Fig. 12.9). Thallium is a potassium analog that, following intravenous injection, distributes itself to all cells of the body in accordance with the balance

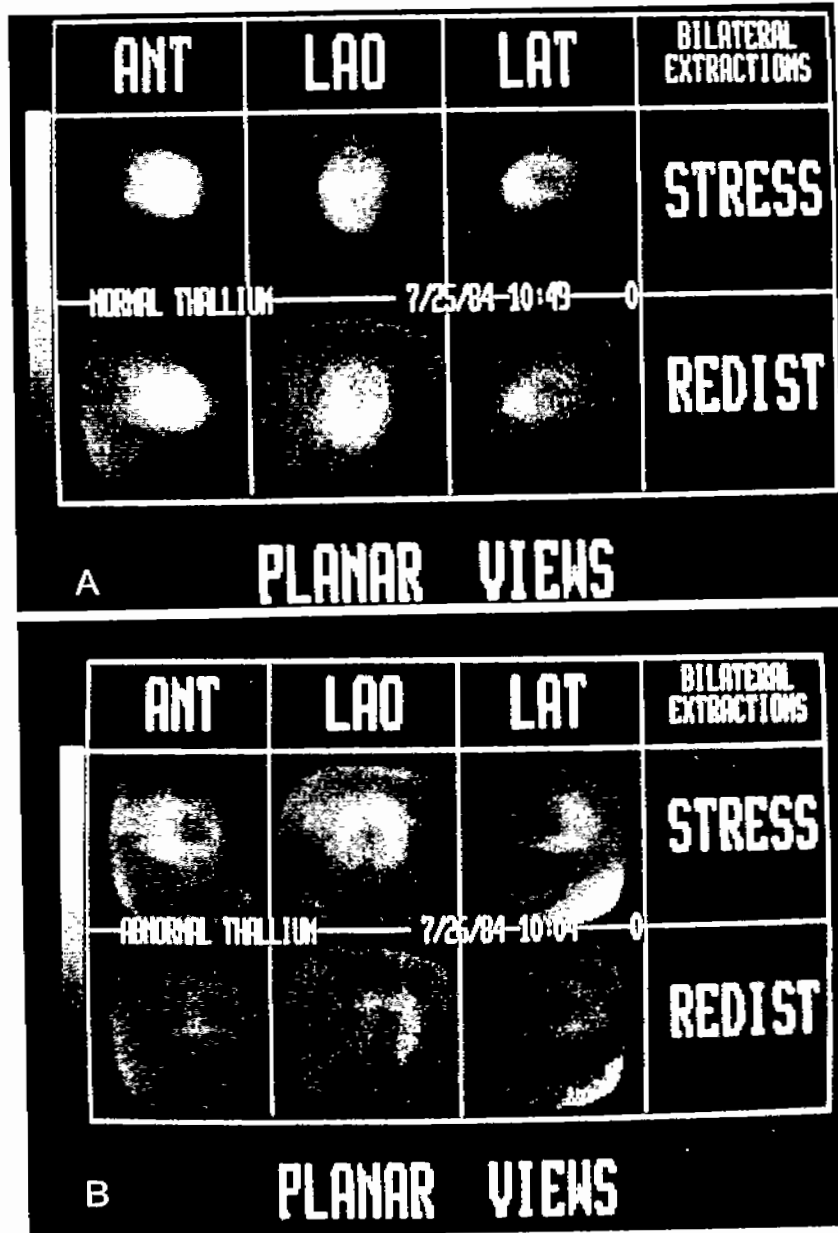

Figure 12.9. Examples of stress (STRESS) and redistribution (REDIST) planar ²⁰¹Tl images taken from ANT, LAO, and LAT projections. A. Normal patient. B. Abnormal patient, with a dilated LV, a large anterior-septal wall defect, and evidence of anterior ischemia demonstrated.

of perfusion and metabolic activity. Like potassium, it is rapidly cleared from the blood stream through an active pumping mechanism and concentrates in actively working muscle cells (myocardium) as well as other cells of the body. Therefore, the concentration of radioactive thallium within the initial postexercise images of the heart muscle represent the relative amount of perfusion and metabolic activity of the myocardial cells. Areas of relatively decreased activity represent areas of diminished perfusion, as in ischemic myocardium secondary to CAD, or areas of reduced demand, as in scar tissue secondary to a myocardial infarction (MI) (Fig. 12.9B).

The distinction between ischemia and MI is important, because early recognition of ischemia may lead to treatment preventing an impending MI. Identical images obtained immediately following and approximately 4 hours after the initial stress injection are useful in differentiating these two disorders. This is because of the phenomenon of "redistribution," which is the cellular exchange of ²⁰¹Tl so as to reflect the changing state of perfusion over time. The patient with myocardial ischemia during exercise usually demonstrates near-normal perfusion in a resting situation, which results in the "filling-in" of a defect seen on the initial stress image, whereas the patient with MI would continue to demonstrate an area of relatively decreased perfusion in a resting situation, which would result in the persistence of a defect seen on the initial stress image. The sensitivity and specificity of the planar imaging methods for the detection of CAD are considerably higher (85–95%) than are those of the ETT only. Planar imaging is not very good at determining the extent of the disease, however. In fact, it may appear normal in patients with balanced multivessel disease, a diagnosis that, due to its poor prognosis, should not be missed.

The computer presently is used by many institutions to acquire planar images. Digital image processing such as background subtraction and filtering have proven to be of some diagnostic value. A very important use of the computer has been the quantitative comparison of the stress and redistribution ²⁰¹Tl images (13, 14). The activity of the images is individually mapped and compared on a regional basis (15)

The regional differences are expressed as a percent washout which can be used objectively to differentiate ischemic from normal and infarcted myocardium (Fig. 12.10). This method is particularly useful, since it is unlikely to give a false negative examination in patients having balanced multivessel disease. In addition, the computer is used with various forms of tomographic imaging. There have been special collimator methods such as the 7-pinhole and rotating slant hole (RSH) methods (Fig. 12.10B). More recently, ²⁰¹Tl rotating camera tomographic imaging has proved to be useful.

Additional Clinical Uses

Early in the history of clinical applications, the scintigraphic computer was used for quantification of patterns produced by the transit of radionuclides through various organ systems. Among these applications was cerebral blood flow analysis which was used to evaluate the timing and symmetry of blood flow patterns in the carotid arteries, the middle cerebral arteries, and the cerebral hemispheres. These studies were acquired in a dynamic frame mode with 1 frame/sec for roughly 60 seconds following the bolus injection of 20 mCi of ^{99m}Tc as pertechnetate or of a renal imaging agent to provide rapid clearance from the blood stream. Data analysis included a time of peak count and a comparison of total counts between corresponding left and right anatomical regions (16).

Computer processing of the lung during ventilation and perfusion studies has been performed to provide a form of functional image in which each pixel is the ratio of percent counts during ventilation to percent counts during perfusion (17). These functional images are referred to as V/Q images. The ventilation study is performed with ¹³³Xe, while the perfusion study is performed with ^{99m}Tc-labeled macroaggregated albumin (MAA) or albumin microspheres. A functional image of the lung in which each pixel of the image represents the clearance half-time or mean transit time (18) of ¹³³Xe during the washout portion of the ventilation study can be produced.

A number of computer methods have been utilized to quantitate kidney function. The major problem associated with kidney evaluations is background subtraction. The kidney is evalu-

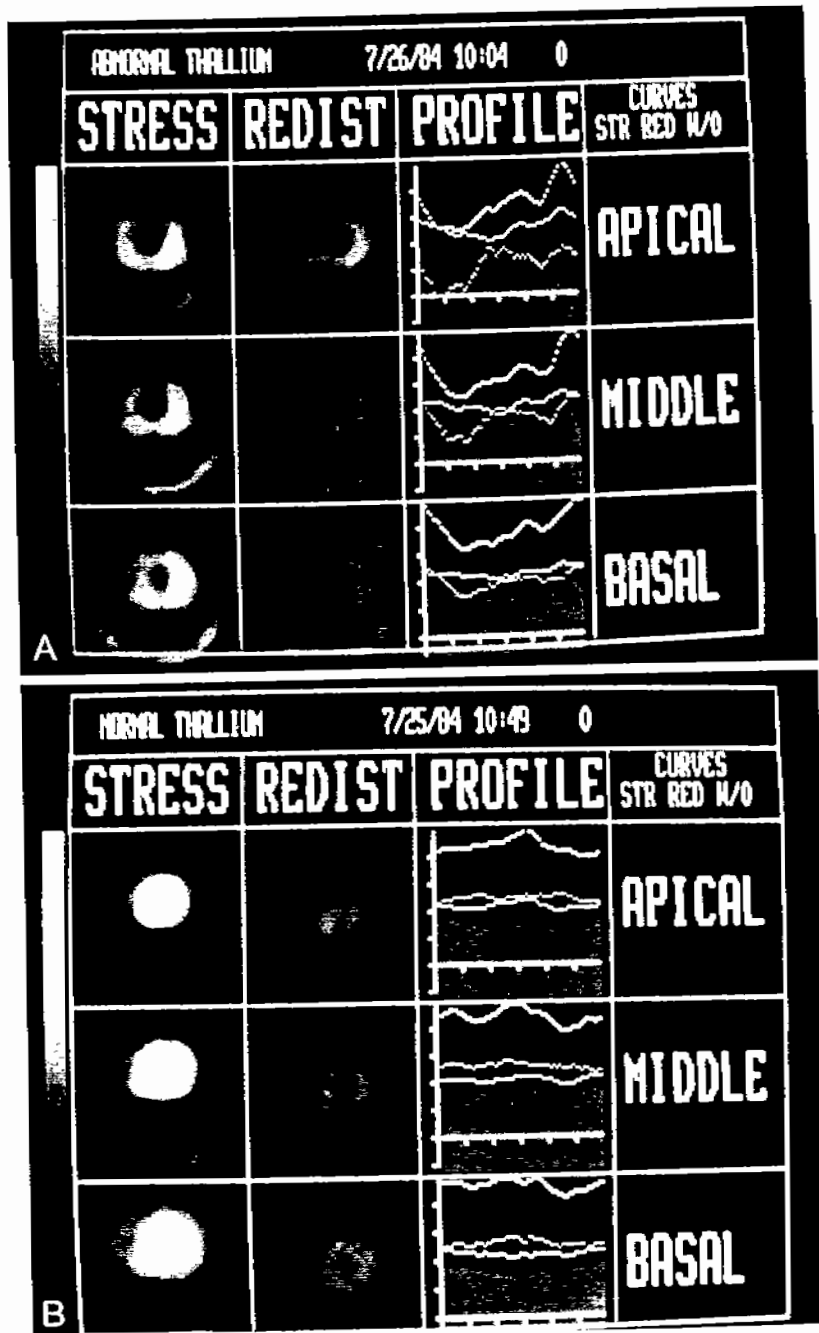

Figure 12.10. Examples of quantitative RSH tomographic images taken from the same patients as in Figure 12.9. Apical, middle, and basal tomographic slices transverse to the long axis of the LV are demonstrated. Profile curves, starting at 3 o'clock and going counterclockwise around the axis of the LV, represent the regional perfusion as a function of angle. Profile curves are calculated from the stress (STR) and redistribution (RED) images and are used in the computation of a percent washout (W/O) curve. The W/O curve is the lightest shade and represents the relative difference between STR and RED on a regional basis; the STR is the darkest curve. The shaded region of the graph indicates abnormal washout. *A* Normal patient. *B* Abnormal

ated by imaging with radiopharmaceuticals which are cleared primarily either by glomerular filtration ($^{99m}\text{Tc-DTPA}$) or by a combination of glomerular filtration and tubular secretion (^{123}I or ^{131}I iodohippurate). Several methods used for measurement of the glomerular filtration rate (GFR) with a scintigraphic computer are reported (19, 20). The assessment of percent function per kidney is possible when imaging is performed. The most accurate procedures for measurement of GFR and effective renal plasma flow (ERPF) are by taking timed plasma samples and utilizing a computer to resolve the plasma concentration curve data into multiple compartments. Observing a cine compressed in time from many minutes to several seconds affords visual inspection of the time course of the radiopharmaceutical within and around the kidneys. This cine often provides information not extracted quantitatively from the study.

The use of scintigraphic computers for time compression is a tremendous diagnostic aid for study of slow-time varying processes in the body. Studies such as gastric emptying, gastrointestinal bleeding, and hepatobiliary imaging, which require continuous acquisition of data for extended periods of time, can be compressed into a few seconds for viewing. By viewing of a cine, patient motion can often be separated from the actual motion of the radiopharmaceuticals. The computer can be thought of as a digital recorder with complete control of playback speed.

Tomography

The scintigraphic computer system is ideally suited to provide the processing necessary for tomographic reconstruction of gamma camera images. The first reconstruction of transverse section tomographic images with use of a gamma camera was reported by Kuhl and Edwards in 1963 (21). This feat amazingly occurred when imaging computers were just being introduced to nuclear medicine. The techniques for single photon emission computed tomography (SPECT) are well known (22–25). Basically, a gamma camera rotates around an object acquiring images at 2–6° intervals. The images are called projections. Most current reconstruction techniques involve filtering of the projection images with a high-pass filter and backpro-

jection of the projection images into the volume scanned.

In order to provide quantitative data in the reconstructed slices, attenuation correction must be utilized. In order to apply attenuation correction, a body contour and attenuation coefficient must be determined. Generally, the body contour is approximated by an eclipse and a constant attenuation coefficient equal to that for the water employed. Additionally, uniformity correction with the collimator on must be made to eliminate potential ring artifacts that may appear in the reconstructed image due to system nonuniformity. A high degree of mechanical accuracy is required to produce SPECT images that are free from artifacts due to error in the center of rotation. With modern technology, SPECT imaging systems produce high-quality tomograms. The rotating camera tomographic systems are limited, because the collimators often are far from the surface of the patient, thus yielding poor resolution. Systems with patient contour tracking will help reduce the resolution losses due to excessive distance. Most SPECT imagers double as planar images with whole-body scan capabilities and provide the user with a broad flexibility in imaging modes.

Limited-angle tomography with 7-pinhole collimators was introduced by Vogel et al. (26). This form of tomography could be achieved with a low-cost upgrade of most computer systems and gamma cameras presently in use. Limited-angle tomography is restricted to imaging small volumes in which most of the activity is concentrated within the organ of interest. This type of tomography has been most successfully used with cardiac imaging. Seven-pinhole tomography requires uniformity correction to compensate for variation in sensitivity across the field of view due to the different distances from a point within an object and the corresponding image of the point within each of the 7-pinhole images.

Limited-angle RSH tomography provides a significant improvement over 7-pinhole tomography (27). This form of limited-angle tomography is low in cost and can be acquired as an upgrade to computers and gamma cameras presently in use. Multisegment RSH collimators with up to four segments have been employed to improve system sensitivity (28). RSH tomogra-

phy has proven to be clinically useful in evaluation of myocardial perfusion with ^{201}Tl . This form of tomography is somewhat immune to gamma camera uniformity problems.

Tomography utilized with annihilation radiation from radionuclides which decay by positron emission is unique to nuclear medicine imaging. One of the most successful of the earlier positron emission tomography (PET) instruments was the PET developed at Washington University (29, 30). PET instruments have evolved from the earlier single-slice imagers to multiple simultaneous slice (up to nine capabilities) (31). PET imagers are believed to have a limiting, full-width half-maximum (FWHM) resolution of approximately 4 mm. An advantage of PET imaging is the availability of positron emitters for elements such as carbon, oxygen, and nitrogen which are of tremendous biological importance. The disadvantage of PET imagers is high cost. In addition, a cyclotron nearby is necessary to provide the large quantities of positron emitters necessary for imaging.

LABORATORY USES

The digital computer is useful in laboratory environments for data storage and retrieval, curve fitting and calculations and, in general, any task that can be reduced to a fixed set of instructions. The computer is best suited to solving problems that require a large number of calculations, just the type problem for which humans are least well suited. Computers are utilized in almost all laboratories to help with data reduction in radioimmunoassay (RIA) procedures. In this role, the computer takes results from a gamma counter in a prearranged order and calculates the standard curve to apply to patient samples to convert from raw counts to units of microgram per milliliter (or whatever units were given for the standard samples). With proper curve fitting algorithms (32), the computer can produce quick and reproducible results for RIA.

The computer has also been used to evaluate plasma clearance rates of various radiopharmaceuticals by analysis of the plasma concentration curve as a function of time. GFR can be assessed from counting plasma samples of ^{125}I -

iothalamate which is primarily cleared from the plasma by glomerular filtration. A common method used to evaluate GFR is to take multiple-timed plasma samples and resolve the plasma disappearance curve into two compartments (19). The GFR is then calculated from the area under the plasma concentration curve and the total activity injected. If ^{123}I or ^{131}I iodohippurate is injected and plasma samples are evaluated in a similar manner, ERPF can be evaluated (19).

A potential area for use of the computer in a nuclear medicine laboratory would be radiopharmaceutical inventory. Records of receipt, use, and storage could be maintained from entries made by the radiopharmacist. Periodic reports can be produced by use of database software customized for the individual user. Software such as dBASE II (or III) and LOTUS 1, 2, 3 can be easily configured to help in data management of radiopharmaceuticals. Several users have reported computerized record keeping and inventory programs for nuclear medicine laboratories (33-35).

Computers can be used to analyze results from wipe or swipe tests for removable radioactive contamination. If energy information (multiple-channel analyzer (MCA) output or multiple-channel counting) for each sample is passed to the computer, a quick check from known samples can provide information as to the most likely radionuclide found and an estimate of the reported level of radioactivity in microcuries or disintegrations per minute. This is extremely useful when many wipe tests are to be evaluated at once. If the gamma counter has digital output (usually paper tape) that the computer can read, the whole process can be automated in terms of data entry. A report can be generated that summarizes the results of the wipe tests.

Although the computer has not met with much success in providing interpretation of clinical images, it has proven useful in providing suggested diagnosis based on laboratory test results from areas such as blood gas evaluations. If a logical approach for interpreting a test or a combination of tests is known, the computer can be useful. For some in vitro tests such as the Schilling test, interpretative reporting of laboratory data is possible (36).

REFERENCES

- Brown DW: The role of the computer in nuclear medicine. *J Nucl Med* 8:376, 1967.
- Brown DW, Kirch DL, Trow RS, et al: Quantification of the radionuclide image. *Semin Nucl Med* 3: 311-325, 1973.
- Jarvis CL, Moore DW: Quantitative analysis of a class of biomedical images by an image processing system. *Comput Biomed Res* 5:540-560, 1972.
- Metz CE: A mathematical investigation of radioisotope scan image processing. Doctoral thesis, University of Pennsylvania. pub no 70-16-186, University Microfilm, Ann Arbor MI, 1969.
- Froelich JW, Thrall JH, Kalff V, et al: Computer analysis of cardiac radionuclide data. *Prog Cardiovasc Dis* 26:43-74, 1983.
- Bacharach SL, Green MV, Borer JS, et al: A real-time system for multi-image gated cardiac studies. *J Nucl Med* 18:79-84, 1977.
- Ken MK, Hopkins GB, Salel AF: Analysis of wall motion abnormalities of the heart and great vessels by computer generated cine-radionuclide-equilibrium study. *Clin Nucl Med* 3:364-369, 1978.
- Taylor DN, Garvie NW, Harris D, et al: The effect of various background protocols on the measurement of left ventricular ejection fraction in equilibrium radionuclide angiography. *Br J Radiol* 53:205-209, 1980.
- Starling MR, Dell'Italia LJ, Nusynowitz ML, et al: Estimates of left-ventricular volumes of equilibrium radionuclide angiography: importance of attenuation correction. *J Nucl Med* 25:14-20, 1984.
- Wendt RE III, Murphy PH, Clark JW: Interpretation of multigated Fourier functional images. *J Nucl Med* 23:715-724, 1982.
- Burow RD, Strauss HW, Singleton R, et al: Analysis of left ventricular function from multiple gated acquisition cardiac blood pool imaging. Comparison to contrast angiography. *Circulation* 56:1024-1028, 1977.
- Okada RD, Boucher CA, Strauss HW, et al: Exercise radionuclide imaging approaches to coronary artery disease. *Am J Cardiol* 46:1188-1204, 1980.
- Garcia E, Maddahi J, Berman D, et al: Space/time quantitation of thallium-201 myocardial scintigraphy. *J Nucl Med* 22:309-317, 1981.
- Meade RC, Bamrah VS, Horgan JD, et al: Quantitative methods in the evaluation of thallium-201 myocardial perfusion images. *J Nucl Med* 19:1175-1178, 1978.
- Llaurado JG: Review: a comparison of computerized quantitative methods for interpreting Tl-201 myocardial scintigraphs. *Int J Biomed Comput* 14:183-194, 1983.
- Colvin J: Cerebral blood flow analysis on a nuclear medicine computer system. In Lieberman DE (ed): *Computer Methods: The Fundamentals of Digital Nuclear Medicine*. St. Louis, CV Mosby, 1977, pp 99-113.
- Arnold JE, Wilson BC: Computer processing of perfusion, ventilation, and V/Q images to highlight pulmonary embolism. *Eur J Nucl Med* 6:309-315, 1981.
- Nosil J, Hughes JM, Hudson FR, et al: Functional imaging of lung ventilation using the concept of mean transit time. *Phys Med Biol* 21:251-262, 1976.
- Dubovsky EV, Russell CD: Quantitation of renal function with glomerular and tubular agents. *Semin Nucl Med* 12:308-329, 1982.
- Ash JM, Antico VF, Gilday DL, et al: Special considerations in the pediatric use of radionuclides for kidney studies. *Semin Nucl Med* 12:345-369, 1982.
- Kuhl DE, Edwards RQ: Image separation radioisotope scanning. *Radiology* 80:653-661, 1963.
- Kay DB, Keyes JW Jr, Simon W: Radionuclide tomographic image reconstruction using Fourier transform techniques. *J Nucl Med* 15:981-986, 1974.
- Jaszczak RJ, Murphy PH, Huard D, et al: Radionuclide emission computed tomography of the head with ^{99m}Tc and a scintillation camera. *J Nucl Med* 18:373-380, 1977.
- Budinger TF, Derenzo SE, Greenberg WL, et al: Quantitative potentials of dynamic emission computed tomography. *J Nucl Med* 19:309-315, 1978.
- Budinger TF, Gulberg GT, Huesman RH: Emission computed tomography. In Herman GT (ed): *Image Reconstruction from Projections—Implementations and Applications*. New York, Springer-Verlag, 1979, pp 147-246.
- Vogel RA, Kirch DL, LeFree MT, et al: A new method of multi-planar emission tomography using seven pinhole collimator and an Anger scintillation camera. *J Nucl Med* 19:648-654, 1978.
- Goodwin PN: Recent developments in instrumentation for emission computed tomography. *Semin Nucl Med* 10:322-334, 1980.
- Lasher JC, Blumhardt R, Kopp DT, et al: Emission Computed tomography: versatile limited angle software. In Esser PD (ed): *Emission Computed Tomography—Current Trends*. New York, Society of Nuclear Medicine, 1983, pp 211-226.
- Phelps ME, Hoffman EJ, Mullani NA, Ter-Pogossian MM: Application of annihilation coincidence detection to transaxial reconstruction tomography. *J Nucl Med* 16:210-224, 1975.
- Ter-Pogossian MM, Phelps ME, Hoffman EJ, et al: A positron emission transaxial tomograph for nuclear medicine imaging (PETT). *Radiology* 114:89-98, 1975.
- Goodwin PN: Recent developments in instrumentation for emission computed tomography. *Semin Nucl Med* 10:327-331, 1980.
- Hill CH, Dworkin HJ: Computers in the radioimmunoassay laboratory. In Lieberman DE (ed): *Computer Methods: The Fundamentals of Digital Nuclear Medicine*. St. Louis, CV Mosby, 1977, pp 114-129.
- Herron DS: A computerized radioactive material inventory system. *Health Phys* 37:598-600, 1979.
- Richards L: A small-scale computerized isotope record monitoring system. *Health Phys* 36:640-642, 1979.
- Hoory S, Levy LM, Moskowitz G, et al: A computerized system for control and management of radionu-

clide inventory: application in nuclear medicine. *Health Phys* 42:601-609, 1982.

36. Lupovitch A, Hasegawa CM: Interpretive reporting of

laboratory data. The Schilling test. *Am J Clin Pathol* 63:434-437, 1975.

II

Problems and Pitfalls Encountered with the Use of Radiopharmaceuticals

Iatrogenic Alterations in the Biodistribution of Radiotracers as a Result of Drug Therapy: Theoretical Considerations

Robert Hodges

For many years, radioisotope tracers were the exclusive tool of researchers for study of biodistribution and physiologic function with highly controlled experimental protocols. As their use in humans proliferated, it was found that these agents behaved in quite unexpected ways in the generally uncontrolled clinical settings. In these early days, only the naturally occurring radioactive isotopes of I, P, Ca, etc. were available. These were elements whose biological distribution had been fairly well established. Moreover, imaging with these agents was intended to identify gross physiological manifestations such as bone demineralization or thyroid physiology.

The advent of ^{99m}Tc provided the first tool for convenient and extensive labeling of a variety of molecules. After questions of safety were resolved, its acceptance was so rapid and its use so diverse that there was little time to investigate just how the body deals with this unfamiliar metal.

Although labeling of biologic molecules with ^{99m}Tc was becoming a common practice, what effect labeling would have on biodistribution of the molecule was not known. Even the nature of the pertechnetate ion was a puzzle long after it became a workhorse of nuclear medicine.

Although pertechnetate was similar to iodine in much of its biologic behavior, researchers recognized the importance of elucidation of its behavior. Even as it was being widely used, studies were launched to investigate protein binding (1) and organification of pertechnetate

by the thyroid (2), as well as the nature of salivary secretion (3, 4), gastric and intestinal secretion (5, 6), and the mode of excretion (7, 8).

As these studies proceeded, journals were increasingly publishing reports by clinicians of the bizarre behavior patterns of pertechnetate in their patients. Many times, it was a pharmacologic agent that was responsible for the unexpected behavior of the tracer. This opened the eyes of practitioners to the fact that many factors, including disease states, surgical procedures, radiation therapy, drug therapy for control of tumor growth, and drugs for supposedly unrelated conditions, could affect the distribution of tracers (9).

Any chemical agent or other influence (including a drug) which alters either the nature of the tracer or the biochemical milieu to which the tracer is exposed may result in unexpected behavior of the tracer (10). Because "abnormal" radiotracer behavior suggests some biochemical anomaly which *may* reflect underlying pathology, it is necessary to rule out the possibility of an artifact, or a physiological alteration that is drug-induced, before diagnosis and subsequent therapeutic decisions can be made with confidence.

In addition, because most drugs exert their therapeutic effect by altering ongoing physiological processes, some effects of drugs can mimic disease symptoms or, in certain instances, induce disease. Such induced disease due to direct drug toxicity, such as acute tubular

necrosis, or more indirect effects, such as systemic lupus erythematosus, may also affect radiotracer distribution and interfere with the differential diagnosis.

FACTORS THAT DETERMINE BIODISTRIBUTION OF RADIOTRACERS

Physical and chemical properties of radiotracers determine, in part, how the radiotracers will localize. Binding to plasma proteins or intracellular constituents of blood cells, relative lipid and/or water solubility, extraction by the reticuloendothelial system (RES), ionic size and mass, active or passive transport systems, cellular metabolism, and binding to receptors may play a role in radiotracer localization (10).

Radiotracer uptake in disease states can be conceptualized in terms of altered regional physiology. Neoplasms, inflammation, and infarcts are characterized by microvascularization which increases perfusion and capillary bed permeability, resulting in entry of macromolecules into interstitial fluid space. In addition, the increased macrophage activity that occurs may result in ingestion of radiolabeled macromolecules, while pinocytosis may result in ingestion by other cells in the lesion. There may also be specific receptor sites on the cell membrane for the radiolabeled macromolecule and possible intracellular translocation of the label (10).

It is evident that the distribution of radiotracers is based on the same pharmacokinetic principles that have been described for therapeutic agents, including structure activity relationships (SARs) and binding to specific receptors.

According to this SAR concept, the actions of a drug are intimately related to chemical structure, and minor modifications in molecular structure may cause major changes in biologic behavior. For instance, it should be possible, with use of knowledge of SAR, to augment specificity of tracers for acutely infarcted myocardium (11).

The concept of a drug receptor is important to the understanding of radiotracer uptake and serves to explain the minute quantity of some drugs needed to elicit a measurable effect. This

concept will also account for the fact that optical isomers of the same molecule frequently have different bioactivity and perhaps will help to explain some mechanisms of tracer uptake. Receptors have been identified for cholinergics, β -adrenergics, insulin, angiotensin II, gonadotropin, glycogen, prolactin, TSH, estrogen, histamines, narcotics, and steroids. Of these, steroid receptors appear to be within the cell, while the others are localized on cellular surfaces. Receptors might be expected to be polymers or portions thereof and would include proteins and nucleic acids (12).

Examples of radiotracers that are thought to have specific receptors are the cationic isotopes and the metabolically active tracers. Lysosomes contain an excess of anionic groups and should demonstrate a considerable capacity for binding of divalent cations which might reach the vesicle interior (13). One group of compounds called asialoproteins are known to bind to receptors found only on the hepatocyte membranes. These agents have been labeled and appear to be excellent hepatocyte imaging agents (14).

DRUG EFFECTS ON BIOLOGICALLY IMPORTANT MOLECULES WHICH MAY RESULT IN CHANGES IN RADIOTRACER DISTRIBUTION

Cell Membrane

A wide range of drug classes exert their pharmacological effects on the cell membrane. Groups such as autocooids and their antagonists, local and general anesthetics, diuretics, antibiotics, steroids, fat-soluble vitamins, and many cations have supposed sites of action on the cell membrane. It is thought that many drugs can cause relatively major changes in the properties of cell membranes. It is likely that the large membrane permeability changes that occur in the presence of some drugs represent upheaval of the membrane ultrastructure, e.g., the creation or enlargement of pores through which lipid-insoluble ions can pass (15). This permeability may occur through a direct interaction between the pharmacologic agent and a particular cell membrane by creation of a channel of an appropriate size and ionic charge to allow passage of the tracer. The pharmacologic agent can enhance cellular expulsion of membrane alter-

ing lysosomal enzymes and cause release of histamines, prostaglandins, or their precursors, or they may initiate chaotic activation of the complement cascade with intense ramifications for membrane function.

Selective membrane permeability is an essential characteristic of the living cell. The most essential active functions of membranes include selective control of the movements of ions and other solutes, packaging and translocation of macromolecules, grouping and orientation of enzyme systems, and transmission of extracellular information to the cell interior (16). Seventeen glycoenzymes have been identified on cell surfaces. Some are involved directly in transport across membranes, and some prepare their substrates for transport by converting them to products that can be handled by other transport systems (17).

Although membranes are much less permeable to cations than to anions, it is known that immunological reactions alter the low cation permeability of membranes. In intact cells, cation permeability is a function of membrane structure and is interdependent with cellular metabolism. Membrane cation permeability may be modified by lectins or antibodies, by activation or inactivation of transport sites, or by changes in kinetic parameters of transport processes (18). The direct-acting cholinergic agents are an example of a class of drugs that increase membrane permeability to cations (12).

Because most neurotransmitters and drug molecules are cationic at physiological pH, acidic lipids are likely candidates to serve in transport mechanisms or to serve as binding sites themselves. Three roles for lipids have been described: (a) direct involvement in ligand binding, (b) service as cofactors for the receptor, and (c) service as regulators for the receptor-effector system, i.e., lipids that surround receptor molecules modulate the three-dimensional structure and regulate affinity for the receptor or regulate the lateral mobility of the receptor and thus control the ligand-receptor complex interaction with an effector (second messenger) such as adenylyl cyclase (19).

Lipid bilayer membranes are highly impermeable to small inorganic ions. A variety of molecules, including the antibiotic valinomycin

and nonactin, interact with lipid bilayer membranes and increase their permeability to small ions via a carrier mechanism comparable with that in the highly ion-permeable nerve membranes. Other membrane-modifying molecules, such as gramicidin A and alamethicin, facilitate the passive diffusion of ions by creating a pathway through the membrane through which ions can move down an electrochemical gradient. Other pore-forming antibiotics are nystatin and amphotericin B (20).

There is extensive literature on the effects of anesthetic drugs on the transmembrane flow of ions and neutral solutes. It appears that the anesthetics can increase or decrease passive and active flows. Facilitated diffusion or carrier-mediated translocation of glucose is inhibited by halothane, methoxyflurane, ether, and various alcohols and detergents. Facilitated transfer of amino acids is inhibited by ethanol. It appears that neutral anesthetics increase passive cation diffusion, while positively charged anesthetics decrease it (21).

A large variety of organic molecules show local anesthetic activity, which suggests that local anesthesia must result from a relatively nonspecific interaction rather than from a specific binding of the drug to a receptor in the membrane (22). This is compatible with more recent concepts of receptors. The traditional "lock and key" model of membrane receptors has been modified to suggest that both the drug and receptor have three-dimensional flexibility and that the surface topography of both can be varied by mutual inductive forces or by other chemical species in the vicinity. Current concepts of molecule-receptor interaction conform to usual chemical bonding phenomena, i.e., covalent, ionic, ion-dipole, hydrogen and van der Waal bonding forces (12).

Many, if not most, of the membrane actions of anesthetics and tranquilizers occur in both excitable and nonexcitable membranes. It is generally assumed that the primary actions of anesthetics are on the cell membrane rather than on the intracellular processes (21).

A relationship between local anesthetic potency and lipid solubility suggests that the primary effect of local anesthetics is on the lipid component of the cell membrane (22). If the

membrane contains lipids in both the gel and liquid-crystalline phases, the addition of anesthetic could, by lowering the lipid phase transition temperatures, trigger a change from the gel phase to the liquid-crystalline state resulting in an increase in fluidity of the membrane (22).

When a lipid undergoes a phase transition, other physical parameters, in addition to the fluidity, change, i.e., both lipid packing density and polar head groups are altered (19). Membranes undergoing a phase transition have shown increased binding of proteins and fluorescent probes as well as enhanced membrane transport of dyes and increased enzymatic activity (24). The degree of membrane fluidity affects enzyme activity such as Ca^{+2} -ATPase, Na^{+} - K^{+} ATPase and the β -galactoside transport system (25). The resultant effect on the transport of tracers is open to speculation.

Following the discovery that cationic, amphiphilic drugs such as chlorpromazine (CPZ) enhance ^{32}P incorporation into phosphatidic acid and phosphatidylinositol, results of subsequent studies have led to the realization that CPZ and other drugs such as local anesthetics, imipramine, amphetamines, and levorphanol act on phosphatidate phosphohydrolase in intact cells. These agents modify the pattern of incorporation of labeled glycerin into glycerolipids of liver lymphocytes. The ultimate effect is an increased cellular phosphatidylinositol content (16).

Phosphatidylinositol, a membrane phospholipid, binds divalent cations avidly, but without great specificity for individual ionic species. Affinity for monovalent cations is much lower (16).

Great strides are being made in the understanding of the multiple roles that the Ca^{+2} ion plays in the regulation of cell function and membrane fluidity. Ionized calcium may be a mediator for a number of cell functions, such as cellular and organellar motility or microtubule fluxes, and may reflect surface membrane changes or other events closely related to cell function (26).

Calcium plays a critical role in control of intracellular cyclic nucleotide concentration through its ability to inhibit adenylyl cyclase,

stimulate guanyl cyclase, and regulate the phosphodiesterase regulator protein (27).

Calcium and acidic phospholipids are intimately involved in excitatory mechanisms of biological membranes, and the displacement of membraneous calcium results in a functional instability of the membrane (27).

It is likely that in biological membranes, Ca^{+2} control of permeability involves specific interactions of Ca^{+2} with proteins. Conformational changes in the protein by itself or in concert with surrounding lipids could be responsible for permeability changes (28).

The divalent and trivalent cations Mn^{+2} , Mg^{+2} , Co^{+2} , La^{+3} and the organic molecules methoxyverapamil and nifedipine are calcium channel antagonists. Some data suggest that the calcium channels may possess gating mechanisms involving phosphatidylinositol breakdown as the initial event required to open calcium channels following agonist-receptor interactions. The organic calcium antagonists that have been developed may block entry of calcium ions from the outside to the inside of the cell and modify the effects of various calcium-dependent agonists. Quercitrin and dantrolene are also Ca^{+2} antagonists. In the Ca^{+2} channel, divalent cations with ionic radii similar to Ca^{+2} may be expected to substitute for or act as antagonists of Ca^{+2} permeation. Both Sr^{+2} and Ba^{+2} can substitute for Ca^{+2} (29).

Hormone-receptor interactions may result in direct changes in the physical, electrical, and biological properties of the cell membrane. These alterations in membrane structure may have implications in the transport of other molecules (30).

Liposome-cell interactions have induced changes in cell membrane composition and a variety of cellular activities. Charged liposomes alter the carrier-mediated transport of divalent anions. Data have indicated a specific effect on the carrier and not a nonspecific increase in membrane permeability. Membrane microviscosity and such properties as osmotic fragility, glycerol, and K^{+} permeability have been altered by liposome interactions with erythrocytes, platelets, normal lymphocytes, and leukemic cells. Liposome studies also show that

the presence of acidic groups within the bilayer increase permeability to cations and decrease permeability to anions. The interactions between liposomes and cells can have profound effects on the properties of cell membranes (31).

It is not yet possible to document the precise effect that the previously discussed factors may play in membrane transport, especially with regard to radiotracers. Technological advances are, however, making possible a much more detailed understanding of membrane permeability and transport of a variety of charged and neutral molecules and particulates. A few suspected drug interactions with radiotracers will be considered later in the chapter in light of the previous discussion of membrane transport.

Blood Components

Concern about alterations in the transport of tracers must focus not only on the effects on membrane permeability but also on interactions of the tracer in particular compartments. For instance, many molecules and blood components found in the circulatory system can interact with tracers. Not only can plasma proteins bind with the tracer, but body tissue may produce antibodies to the tracer. The tracer may also interact with red blood cells, platelets, and neutrophils. The fate of the tracer is then dependent on the destiny of the blood component. Fewer binding sites may be available to tracers that bind to serum protein if therapeutic doses of drugs that are highly protein bound are present in the blood pool. Their presence could be expected to alter the biologic half-life of the tracer, as larger numbers of the tracer molecules are free of binding and are available for elimination or for interacting with cell membranes or with other agents in the blood stream.

Enzymes

Because cells are enzymatically controlled, that drugs have an effect on enzyme function suggests a possible interference. Several enzymes regulating synthesis of critical cellular constituents have been shown to be affected by drugs at clinically obtainable blood and tissue levels. These enzymes include acetylcholin-

esterase, aldehyde dehydrogenase, carbonic anhydrase, dopa decarboxylase, monoamine oxidase, and xanthine oxidase.

MECHANISMS BY WHICH DRUGS MAY AFFECT DISTRIBUTION OF SPECIFIC RADIOPHARMACEUTICALS [$^{99\text{m}}\text{Tc}$]Pertechnetate

After intravenous injection of pertechnetate, a large fraction of the activity leaves the blood within 1 or 2 minutes and equilibrates in various compartments (5). It is selectively taken up by the stomach, thyroid gland, salivary glands, mucosal lining of the nasal sinus, and choroid plexus (32).

The effectiveness of pertechnetate for traditional brain imaging depends on its distribution in the extracellular spaces and on its exclusion from normal brain tissue (33). It is generally believed that it is the blood-brain barrier (BBB) that is responsible for the exclusion of pertechnetate from normal brain tissue. Uptake of pertechnetate by the choroid plexus, salivary glands, and oral mucosa interferes with brain scan interpretation. The use of oral perchlorate to block uptake in the choroid plexus is routine practice in nuclear medicine departments that utilize pertechnetate for brain scans. Perchlorate works by competitively inhibiting the uptake of pertechnetate by the choroid plexus and salivary glands, thus preventing an increased discharge into the cerebrospinal fluid (CSF) and saliva. The synthetic anticholinergic drug glycopyrrolate has been used in place of perchlorate for almost complete elimination of activity from the choroid plexuses and mouth and for moderate reduction in parotid gland activity (34).

The ability of perchlorate and other agents to attenuate or block the uptake of pertechnetate at its usual uptake sites has generally been advantageous. Since these agents block several secretion routes, tissue concentrations in blood, tumor, and brain are generally increased. These levels decline more slowly, which results in prolonged tissue concentrations. This effect may or may not be advantageous, depending on the tissue ratio and the type of tumor being imaged (35).

It has been shown that in rabbits, perchlorate causes a major tissue redistribution of pertechnetate, probably resulting from release of pertechnetate from plasma protein-binding sites with redistribution to tissue extracellular spaces and a shift intracellularly. With regard to blood plasma, the pertechnetate content of scalp, lumbar skin, skull, muscle, and brain is increased significantly. Pertechnetate also moves from plasma into red cells within 2 or 3 minutes after perchlorate administration, and the degree of protein binding drops from 80% to 40% during this time (36).

Practitioners, in attempting to explain unexpected uptake of pertechnetate-labeled ligands, sometimes discount the possibility of dissociation of tracer from the ligand because they do not observe stomach or thyroid uptake of pertechnetate. However, a rapid red blood cell (RBC) uptake of the liberated pertechnetate, as is observed with tin during *in vivo* labeling of RBC, could conceivably occur under the right conditions.

The protection afforded by the BBB is lost when tumors, cerebrovascular accidents, abscesses, and other abnormalities break down the BBB and allow abnormal tissue accumulation of radiotracers (37). The uptake of tracer often is much higher in brain tissue adjacent to tumors than in distant areas of the brain. This local uptake may be as much as or even more than that of the tumor itself. Uptake of radioactivity by edematous tissue could explain the widening of the radioactivity zone surrounding some tumors (38). It is known that excessive amounts of protein may pass from the capillaries into tissue and contribute to the local edema and, in the process, transport protein-bound pertechnetate to the tumor site. Capillary damage due to the release of toxins and to the development of local lactic acidosis also contribute to the vasogenic edema and protein extravasation (39). Dexamethasone has been shown to be superior to other steroids in reducing cerebral edema secondary to intracranial tumors (40). It should be noted that steroids reduce the tumor accumulation of ^{99m}Tc -diethylenetriaminepentaacetic acid (DTPA) which is not significantly protein bound (41).

Pinocytic activity in brain capillaries in those areas protected by the BBB is known to operate at very low levels under normal conditions. In contrast, in almost every study of pathologic damage of the BBB during which the capillary macromolecular transfer is enhanced, a considerable increase in the number of pinocytic vesicles has been reported (42). That capillary adenylyl cyclase could be activated by histamine receptors reflects an important pathologic phenomenon. It has been proposed that in pathological cases, effective pinocytosis giving rise to an increase in certain transport processes of brain capillaries could be derived from the enhanced cyclic adenosine monophosphate (cAMP) production occurring due to the activation of capillary adenylyl cyclase (43). Since brain cAMP can be increased by a variety of means, including catecholamines, histamines, serotonin, electrical impulses, and other depolarizing agents such as high potassium concentration, cAMP may play an important role in situations in which the BBB breakdown occurs via pinocytosis (44).

Study of mammalian cell cultures define pinocytosis as the cellular ingestion of fluids. The uptake of solutes during pinocytosis is due to their presence in the fluid ingested. It may be that pinocytosis takes part in the nutrition of the cell and also serves as a means of recycling membrane components utilized during exocytosis. Agents reported to induce cAMP-mediated pinocytosis include inorganic salts, proteins, biological stains, macroglobulins, and albumin (45).

Elevated plasma aluminum has been reported to alter the *in vivo* distribution of [^{99m}Tc]pertechnetate (46). In the hemodialysis patient, in particular, there is the potential for interference with pertechnetate distribution. Hyperaluminumemia sufficient to cause encephalopathy has been reported to result from the presence of aluminum in the dialysate solution. In addition, aluminum-containing antacids are frequently prescribed as phosphate binders for patients with chronic renal disease. This situation affords additional opportunity for development of hyperaluminumemia in the dialysis patient. It has been further observed that the administration of

parathyroid extract prior to aluminum ingestion increases intestinal absorption of aluminum in rats (47). This observation should raise some question as to the degree of aluminum absorption in hyperparathyroid patients.

With use of pertechnetate in brain scans, ill-defined, diffuse activity may be observed following contrast cerebral angiography with Renografin 60. Contrast material used for angiography alters the BBB and permits a detectable concentration of radioactivity to linger in cerebral parenchyma up to 6 hours after injection. The greater concentration of activity has been reported to be at the perimeter, which would indicate that the cortex is most sensitive to Renografin 60 (48). Vascular endothelial injury produced by antigen-antibody complexes may result in blood coagulation, fibrinolysis, and the generation of bradykinin (49).

When tin complex (citrate or pyrophosphate) is administered prior to pertechnetate, the distribution of the tracer is altered, the concentration in cerebral pathology is reduced, the concentration in mucous cells in the stomach, thyroid and salivary glands, and the choroid plexuses is increased, and there is a shift of pertechnetate from plasma to the RBC. These kinetics appear to be affected by the action of Sn^{+2} which seems to localize preferentially at the sites listed, forming stable complexes capable of reducing pertechnetate anion and fixing it at the tin-binding site (50).

RES-imaging Agents

In 1924, the term reticuloendothelial system (RES) was introduced to describe a body of mesenchymal-derived cells that form a diffuse system of sessile and wandering mononuclear macrophages that have the ability to rapidly ingest foreign particulate matter (51).

RES constitutes an important part of cellular host defense in the removal and degradation of bacteria, endotoxin, tumor cells, and foreign material from the blood (52). This removal and degradation process is accomplished by fixed macrophages of the RES whose anatomical proximity to the circulation enables them to have direct contact with such blood-borne matter. It includes macrophages localized in the

blood sinuses of the liver, lung, spleen, and bone marrow (51). The RES is a complex system and is far from being understood; nevertheless, wide use is made of its reaction to radiolabeled sulfur colloid and albumin colloid. Liposomes and vesicles are colloid droplets which may, someday, be found to play a significant role as carriers of radioactive labels (53).

The physiological activities of the RES and the factors that influence this diffuse system of fixed and mobile macrophages are numerous. The involvement of the RES in lipid metabolism, protein metabolism, iron metabolism, tumor growth, shock, radiation therapy, infection, and a variety of immunological processes has been adequately documented (51).

In addition, activation of the RES during bacterial infection and diseases of autoimmunity has been suggested to be a physiological host defense response, while depression of the RES associated with circulatory failures may be a crucial factor in the development and progression of a disease process (51).

The RES, as a constituent of the vascular system, can be affected by at least two routes: (a) vasomotor system and (b) substances circulating in the blood and lymph. In the former, the autonomic nervous system, vasoactive amines, or vasotropic tissue substances may diminish transport of substances bound for the RES. In the latter, shortage of plasma factors promoting phagocytosis, blockage of phagocytic sites by cell debris or fibrin products, and the appearance of endotoxins or lysosomal enzymes that damage the RES cells may reduce the ability of the RES to respond in an expected manner (54).

The functional state of the macrophage is a major factor determining the rate of intravascular phagocytosis by the RES. Glucan, zymosan, estrogen, endotoxin, and *Bacillus Calmette-Guérin* (BCG) are potent RES stimulants, while cortisone, methyl palmitate, ethyl palmitate, and antilymphocyte serum are potent RES depressants. There are differences between negatively charged colloids and positively charged colloids, as measured *in vitro*, with respect to both the rate of vascular clearance and relative hepatic distribution. Although it is rec-

ognized that the chemical and physical properties of the surface of the entity being phagocytized will have significant effects on its rate of removal, the relationship between the *in vitro* measurements of the charge of a particle and the actual charge of a particle circulating *in vivo* remains to be ascertained, since particles with different electrophoretic mobilities in the absence of serum have been shown to exhibit similar charge characteristics when they have been incubated with serum (51).

Data suggest that adherence of particles on phagocyte membranes may be a passive process not dependent on a metabolic energy expenditure, while ingestion of the particle by the reticuloendothelial cell is an active process. In this regard, metabolic inhibitors severely limit the ingestion phase of phagocytes. In addition, variation in age, organ size, body weight, blood flow, temperature, cellular metabolism, hormonal levels, and reticuloendothelial cellular population dynamics can profoundly influence intravascular phagocytic activity (51).

Phagocytes have the ability to discriminate foreign macromolecules and tissue debris from healthy endogenous matter. The ability of macrophages to distinguish "self" from "nonself" appears to be mediated by a plasma protein (opsonin) that interacts with foreign macromolecules, making them susceptible to phagocytic ingestion (51).

The clearance of blood-borne particulate material has been shown to be mediated through interaction of particulate matter with opsonizing proteins in the plasma. The removal of bacteria appears to be mediated by the action of a specific antibody complement component. In contrast, removal of nonbacterial colloid and particulate matter has been shown to be mediated by an aspecific opsonin. Consumptive depletion of both specific and nonspecific opsonic protein has been documented and has been shown to be the major determinant of RES function during reticuloendothelial blockage rather than physical saturation of reticuloendothelial cells (55).

Selective membrane adherence probably is associated with the physical and chemical properties of the opsonized particles, the characteristics of the membrane of the macrophages,

and/or the presence of specific receptor sites on the macrophage (51).

Theoretically, heparin may affect the RES function by at least four mechanisms: (a) interaction with the surface of the particles directly, (b) interaction with plasma opsonins, (c) binding to the cell surface of the macrophages, and (d) influencing the lysosomal enzyme activity of the macrophages. Heparin injected intravenously has been shown to accumulate mainly in the RES, suggesting that heparin may affect phagocytic activity at the cellular level. The possibility that heparin binds at a specific receptor site on the macrophage is suggested by the observation that heparin depressed the internalization of microaggregated albumin particles by the RES, which could be attributed to an increase in the negative charge density of the macrophage cell surface and could result in an impaired attachment of the negatively charged albumin particles (52). Other studies suggest that heparin increases the pinocytotic activity of cells such as fibroblasts (51).

Intravenously injected colloids usually distribute within the body according to regional blood flow and phagocytic activity of the liver and spleen. Occasionally, however, uptake is observed in the lungs and kidneys. Animal studies have shown that injection of thromboplastin or production of intensive burns resulted in a marked increase in uptake of colloidal carbon by the lungs. Pretreatment with heparin prevented this increased uptake, suggesting that intravascular coagulation and fibrin formation played a role in lung accumulation of colloid or, alternatively, that heparin prevented the attachment of colloidal carbon to the macrophage membrane. Pulmonary microcirculation studies have shown that following the injection of endotoxin, damaged endothelium can be detected by progressive adherence of intravenously injected colloidal carbon to its surface. Subsequently, the endothelial cells swell and the colloidal carbon appears within the cells, suggesting phagocytosis (56).

The plasma complement (C) system is involved as an antimicrobial defense mechanism. The usual succession of events in complement activation begins with antibodies; an alternate

pathway can be activated without involving antibodies, however, by diverse materials such as lipopolysaccharide (endotoxin), inulin, and zymosan. These compounds trigger activation of C3 directly and generate peptides that potentially affect leukocyte, especially granulocyte, function (57).

Some drugs may cause histamine release from mast cells without antibody mediation in a predictable dose-related fashion. This includes opiates and radiographic contrast agents. These contrast agents also activate complement via the alternate pathway. A few cases of disseminated intravascular coagulation have been reported in humans following injection of contrast agents (49).

Various elements of the complement system are responsible for endothelial adherence and chemotaxis of granulocytes as well as opsonization. One complement component is thought to activate granulocytes to produce microbicidal oxygen radicals (superoxide and hydrogen peroxide). It is believed that these radicals may act as attractants for other phagocytes in the area. Data suggest that complement is activated in shock states incited by sepsis, hemorrhage, and trauma. A serious and frequently fatal consequence of shock thought to be due to prolonged activation of complement is a condition known as "shock lung." One of the features of this syndrome is a unique plugging of the lung microvasculature by granulocytes and monocytes. Pulmonary abnormalities occurring in hemodialyzed patients produced similar but less pronounced pulmonary abnormalities. It was reported that in animal studies, virtually all circulating granulocytes were removed from the circulation and were found to be in leukocytic plugs in pulmonary microvasculature in the early stages of hemodialysis. This finding suggests the possibility of complement activation, as plasma flows over the cellophane dialyzer coils of the hemodialysis apparatus (57).

It is not surprising that dialyzer cellophane could activate complement, since cellophane is a polysaccharide such as zymosan, inulin, and endotoxin, all of which are capable of inducing complement activation (58).

As mentioned previously, free radicals of

oxygen are generated by granulocytes during complement interaction. These radicals are responsible for the endothelial damage, as has been shown by the inhibition of damage in cultured cells by free radical scavengers. Although endotoxin alone has no deleterious effects, significant damage occurs when it is added with granulocytes, especially in the presence of complement fresh serum (57).

The mechanism of leukostatic plugs and the nonmicrobial activation of complement (e.g., by pharmacologic agents) should be considered in the assessment of any unusual lung uptake of radiotracers.

Experimental evidence suggests that the secretion of lysosomal hydrolases from human polymorphonuclear leukocytes can be modified by agents that affect cyclic nucleotides and microtubules (59). There also is evidence that agents that activate a lymphocyte cyclic nucleotide (cAMP) such as isoproterenol, norepinephrine, aminophyllin, and some members of the prostaglandin family interfere with antigen-induced transformation of human lymphocytes *in vitro* (60). Thus, any tracer localization mediated by leukocytes may be affected if the transformation is altered.

Agents that increase intracellular cAMP have been implicated in the flow of subcellular organelles in various systems and may interact with microtubule protein. Studies indicate that the release of enzymes from phagocytes after particle ingestion is a selective process which does not necessarily involve generalized membrane damage. cAMP acts as the second messenger for the effects of many polypeptide hormones on target tissues and mediates the rearrangement of the vacuolar apparatus observed in stimulated organs. It mediates (a) glucagon-induced formation of autophagic vacuoles in liver, (b) endocytosis in thyroid following stimulation with TSH, (c) induction of exocytosis in osteoclasts, parotid, and pancreas by parathyroid hormone (PTH), catecholamines, and insulin, and (c) melanocyte-stimulating hormone (MSH)-induced granule dispersion in melanocytes (61).

Human leukocytes possess specific and separate receptors for endogenous hormones includ-

ing β -adrenergic catecholamines, histamines, and prostaglandins. Each of these stimulate accumulation of cAMP in suspension of mixed human leukocytes. It has been reported that α -adrenergic agents, which decrease cAMP levels, and cholinergic agonists enhance the immunologic release of histamine and SRS-A from lung fragments (59).

Other agents have the ability to increase intracellular cAMP. Prostaglandin E not only is associated with increases in cAMP but also has been associated with the movement of subcellular organelles and may interact with microtubule protein (61). In addition, cAMP is thought to impair RNA or protein synthesis in macrophages during enzyme formation (60). Chloramphenicol and tetracycline have been shown to affect phagocytosis by blockage of DNA and RNA synthesis (54), perhaps by the same mechanism. Other agents such as the methyl xanthines have an indirect effect. These agents are potent inhibitors of phosphodiesterase needed for deactivation of cAMP resulting in sustained high levels of cAMP. Thus data suggesting cAMP as a second messenger in many humoral systems of the body, especially in the RES, raise the possibility that pharmacologic agents known to alter cAMP levels may affect RES function and hence the distribution of colloids (67).

One possible interference in phagocytosis is the altered state of microtubules that develops between phagocytic vacuoles and lysosomes. Drugs with this capability are colchicine and vinblastin. These drugs have been shown to inhibit urate crystal phagocytosis, intracellular digestion, redistribution of granule-associated hydrolases, and antigen-induced release of histamine (61).

Phagocytosis of zymosan particles by rabbit polymorphonuclear (PMN) leukocytes was inhibited by hydrocortisone, methyl prednisolone, and chloroquine. The concentration of drugs inhibitory to phagocytosis was substantially higher than that of drugs required for inhibition of chemotaxis *in vitro*. Thus these agents inhibit the inflammatory process by preventing the response of leukocytes to chemotactic stimuli (62).

Miscellaneous other agents have been shown to affect the RES. Local anesthetics paralyze

leukocytes completely at low concentrations and decrease their hexose monophosphate shunt activity and myeloperoxidase-mediated iodination at even lower concentrations. General anesthetics hamper both phagocytic and catabolic reticuloendothelial functions and impair immune response by leukocytes. The plasma expander dextran, which is a large colloid, is known to be partly engulfed by reticuloendothelial cells. Total parenteral nutrition with hypertonic amino acids and dextrose can result in a 50% reduction of chemotactic phagocytic and bactericidal activity of granulocytes. Protein deficiency also has been shown to result in a diminished uptake of colloidal carbon by Kupffer cells. Extracorporeal circulation, as in renal dialysis, also may depress RES function (54).

The administration of natural or synthetic estrogens markedly stimulated the phagocytic activity of the RES in experimental animals and can result in pronounced RES organ hypertrophy. Other studies demonstrating a dose-related increase in reticuloendothelial phagocytic activity without RES organ enlargement appear to suggest that RES stimulation following estrogen can be the result of increased RES cell activity rather than RES proliferation (63).

Some drugs used for diverse therapeutic effects are estrogenic. Spironolactone, a diuretic agent, has known estrogenic effects and has been known to produce gynecomastia in males (64).

Under normal conditions, there is only minimal uptake of ^{99m}Tc -labeled sulfur colloid in kidney tissue, and data do not suggest migration of reticuloendothelial cells to the kidney. Several theories have been proposed to explain the incidence of renal localization of radiocolloid. The most likely of these suggests that changes in renal flow could induce phagocytic activity in the proximal convoluted tubular cells. Reduced blood flow to the kidneys could occur in congestive heart failure (65) or potentially as a result of drug therapy that causes cardiac output to be reduced.

Renal accumulation of ^{99m}Tc -labeled sulfur colloid has also been reported in renal transplant patients during rejection and during episodes of acute tubular necrosis (66). Several of the commonly used antibiotics, especially kanamycin,

are known to cause acute tubular necrosis (67).

Blood platelets, under normal circumstances, circulate as smooth, disk-shaped nonadherent cells. When endothelium is broken or disruption of vessels allows blood to come into contact with elements of the vessel wall or perivascular space, platelet adhesion occurs which initiates a secretory response during which subcellular granules extrude substances from the cell. This extrusion process resembles the secretory activity of other cells such as endocrine cells and mast cells (68).

Blood platelets have been implicated in mediating not only hemostasis and thrombosis but also various types of inflammatory and immunologic processes, vascular permeability, host-defense responses, and transplant rejection reaction (69).

Increased sensitivity of platelets to aggregating agents such as ADP, epinephrine, and collagen occurs in heart disease, type IIa hyperbeta-lipoproteinemia, transient attacks of cerebral ischemia, hypertension, angina pectoris, myocardial infarction, and factors such as smoking and the use of oral contraceptives (70).

Many agents that cause platelets to release their granule contents activate phospholipase A_2 of the platelet membrane which frees arachidonic acid from platelet membrane phospholipid. The arachidonic acid is converted to prostaglandin endoperoxides and thromboxane A_2 . These agents can cause platelet aggregation and the release of granule contents (70). Substances released from platelet granules include serotonin, a protein that can neutralize heparin, acid hydrolases, and factors that can modify vascular permeability and integrity. These factors can have wide biological implications (68).

Indomethacin and phenylbutazone inhibit release and aggregation of platelets temporarily (69), while aspirin effects last longer due to the irreversible acetylation of cyclo-oxygenase in platelets (71). Other drugs that can inhibit platelet function include tricyclic antidepressants, antihistamines, ethyl alcohol, clofibrate, carbenicillin, dextran, high doses of penicillin, nitrofurantoin, pyridazine compounds, phenothiazines, and volatile anesthetics (69).

The enzyme lipoxxygenase, isolated from human platelets, generates a derivative of arachidonic acid which, during inflammation, exhib-

its chemotaxis for PMN leukocytes. PMN leukocytes release prostaglandin (PGE_1) during phagocytosis which is also chemotactic for PMN cells (72). Thromboxane A_2 is the most potent aggregator metabolite of arachidonic acid which has been identified (73). Prostacyclin is the most powerful substance known to prevent aggregation; it increases cAMP levels in platelets (71). Prostacyclin released into the blood stream by pulmonary circulation constantly activates platelet adenylyl cyclase and increases platelet cAMP, thus decreasing aggregability. Phosphodiesterase inhibitors could potentiate the effect of circulating prostacyclin on platelets (74).

Bone-imaging Agents

Pyrophosphate (PYP) has been found to be present in normal plasma, urine, and saliva and in bone and teeth. Because of its presence in calcified tissues and surrounding fluids, PYP may protect soft tissue from mineralization, regulate the onset of calcification, and influence the rates of entry and exit of calcium and phosphate in bone. Hydroxyapatite (HA) crystals have a marked ability to absorb PYP. This affinity may inhibit nucleation and subsequent growth and aggregation of crystal nuclei of HA. Other modes of action for inhibition of mineralization, besides direct action on crystals, are possible (75).

Electron microscopic observations indicate the presence of extracellular membranous matrix vesicles in epiphyseal cartilage. The very first crystals of HA appear to be associated with these vesicles. They contain most of the alkaline phosphatase, ATP, and pyrophosphatase activity of the epiphyseal cartilage. It has been postulated that because of the enzyme content, membranous nature, and location of these vesicles, they may be involved in the calcification process. Thus hydrolysis of ATP by ATPase present in the matrix vesicles forms orthophosphate and facilitates Ca^{+2} uptake, resulting in the calcification process. Similar vesicles have been seen in immature bone, dentine, and calcifying aorta (76).

Hydroxyethylidene diphosphonate (HEDP), used therapeutically, could interfere with the functioning of these vesicles. It has been suggested that low concentrations of PYP promote

the earlier stages of calcium accumulation by the vesicles, perhaps by acting as a substrate for the calcium pump. HEDP might compete for PYP at this site and block calcification. Changes in the cell populations of skeletal tissues, including epiphyseal cartilage and pagetic bone, and in the morphology of bone cells, especially osteoclasts, are seen when diphosphonates are given therapeutically (75).

An extracellular fluid (ECF) space lies between the capillaries and the bone surface. The rate of tracer transfer from the ECF to osteoid in relation to the rapid diffusion from capillaries to the ECF is slow. Increasing velocity of blood flow is without significant effect on tracer deposition on osteoid surfaces. If sympathetic nervous control of microvasculature is blocked, however, vessels that are normally closed will open, and areas of osteoid not normally exposed to tracer will be able to participate in tracer uptake. Computer perturbation studies show that bone is highly sensitive to changes in extraction efficiency resulting from hormonal alterations. Thus, both hyperparathyroidism and hyperthyroidism result in high-contrast "super-scans" (77).

A direct role for lysosomal enzymes in collagen degradation has been suggested. Lysosomal proteases may complete the degradation of collagen and may be necessary to cleave intermolecular cross-links between collagen molecules, making them susceptible to collagenase. Dibutyryl cAMP (DBcAMP), a bone reabsorption stimulator, causes an increased lysosomal enzyme release. Other agents that increase lysosomal enzyme release and ^{45}Ca release include isobutylmethylxanthine and calcium ionophore A23187 (78).

Decreased release of lysosomal enzymes occurred in parallel with decreased ^{45}Ca release caused by inhibitors of bone resorption such as cortisone, colchicine, and salmon calcitonin. Other inhibitors of lysosomal enzyme release that were also found to inhibit bone resorption in culture systems were stilbamidine, chloroquine, and dapsone (78).

Calcitonin is a hormone that inhibits bone resorption and is known to cause suppression of elevated urinary hydroxyproline excretion. Kinetic studies indicate that calcitonin may have a

significant effect on $^{99\text{m}}\text{Tc}$ -diphosphonate clearance from blood, i.e., an increased rapidity of blood clearance of the tracer. Bladder activity was observed earlier in the calcitonin-treated patients than in the non-calcitonin-treated patients, possibly due to a decrease in the proximal renal tubular reabsorption of electrolytes in patients with Paget's disease (79).

Calcitonin has been shown to convert the lower and upper part of the small bowel from an absorbing organ to one that secretes water, sodium, chloride, and potassium (80).

The administration of 1.25 mg of vitamin D_3 intravenously in rats caused a significant decrease in the uptake of $^{99\text{m}}\text{Tc}$ -PYP and $^{99\text{m}}\text{Tc}$ -diphosphonate by bone. Administration of 1.25 mg of dihydrotachysterol by stomach tube caused a significant increase in the ratio of infarcted myocardium-to-bone uptake of $^{99\text{m}}\text{Tc}$ -PYP (81). Observations such as this led to the search for agents that would favorably influence the tracer distribution (82–86).

Parathyroid hormone (PTH) elevation in serum has been observed to increase urinary excretion of $^{99\text{m}}\text{Tc}$ -PYP (87). This observation suggests at least the potential that drugs which influence PTH levels may have some effect on excretion of $^{99\text{m}}\text{Tc}$ -PYP or other bone-imaging agents.

Altered distribution of the bone agents diphosphonate and pyrophosphate, in the presence of Ca^{+2} and Fe^{+2} , has been observed. These metal ions may facilitate the dissociation of $^{99\text{m}}\text{Tc}$ from the carrier ligand, resulting in both $^{99\text{m}}\text{Tc}$ deposition at the reaction site as well as translocation to other tissues, possibly with the migrant $^{99\text{m}}\text{Tc}$ bound to another ligand. The formation of Ca -HEDP complexes in the presence of calcium gluconate could release $^{99\text{m}}\text{Tc}$, followed by scavenging of the liberated $^{99\text{m}}\text{Tc}$ by gluconate to form a ligand with renal imaging properties. In the absence of gluconate the Ca -HEDP reaction produces a significant amount of liver agent, possibly colloidal $^{99\text{m}}\text{TcO}_2$. Such transchelation may account for the fact that pyrophosphate and diphosphonate are effective imaging agents for myocardial infarction (88).

Other potential drug interactions are suggested by the fact that $^{99\text{m}}\text{Tc}(\text{Sn})$ at high pH in

the presence of appropriate dihydroxyglycols other than gluconate, such as gluceptate, mannitol, and ethylene glycerol, gives essentially the same tissue distribution as observed with $^{99\text{m}}\text{Tc}$ -gluconate (88).

Other glycols are present in pharmaceuticals. Polyethylene glycol is present in Gris-PEG (griseofulvin), and propylene glycol is present as a stabilizer agent in poorly soluble injectables such as phenytoin, digoxin, phenobarbital, and hydralazine.

Agents containing gluconate include Kaon (potassium gluconate), quinidine gluconate by injection, and Quinaglute Dura-Tabs (quinidine gluconate tablets). A product that contains a congener of gluconate is guaifenesin which is found in some cough preparations.

Uptake of $^{99\text{m}}\text{Tc}$ -labeled phosphates at the site of intramuscular injections of an iron dextran complex has been reported (89). One explanation for this phenomenon is the combination of ferric hydroxide and reduced technetium, as this combination is released from the iron dextran complex (90).

Additional reports of the effect of iron on tissue distribution of phosphorus-containing bone agents suggests a relationship between the degree of iron overload and the decrease in skeletal uptake. Patients with a history of transfusion and hemochromatosis showed reduced skeletal uptake of bone agent, which correlated with the degree of expected iron overload in these patients (91).

Liver uptake of $^{99\text{m}}\text{Tc}$ -Sn-HEDP has been demonstrated in the presence of Al^{+3} ions possibly leached from the technetium generator. This uptake was believed to be due to the formation of a colloidal complex, although particles were not visible under light microscopy (92). Tissue burdens of aluminum have been found to be increased in a number of conditions. Although the gastrointestinal tract is a formidable barrier to the entry of aluminum, it cannot be considered to be impervious. Plasma aluminum levels have been reported to rise markedly during ingestion of aluminum hydroxide, aluminum carbonate, and aluminum aminoacetate. In contrast to aluminum phosphate, these aluminum compounds are soluble at the pH of the proximal duodenum or stomach. With sol-

ubilization, Al^{+3} could be absorbed (93). It has been suggested that should there be an altered distribution of $^{99\text{m}}\text{Tc}$ -HEDP, the Al^{+3} content of $^{99\text{m}}\text{Tc}$ eluant and the patient's serum be checked (94).

An atypical bone scan with use of $^{99\text{m}}\text{Tc}$ -diphosphonate was reported in a patient receiving Phospho-Soda. The scan was characterized by poor skeletal uptake with increased tracer activity in the stomach, thyroid, and lungs. The poor bone uptake of the tracer might result from saturation of bone binding sites by phosphate ions from the Phospho-Soda preparation (95).

Phospho-Soda contains 0.14 gm of phosphorus per ml. The recommended purgative dose is 10–20 ml (1.5–3.0 gm of phosphorus). Phosphate can lower serum calcium with no increased fecal or urinary excretion of calcium. This lowering may be due to extraskelatal deposition of calcium phosphate salt. Extensive calcification has been reported with orally and intravenously administered phosphate preparations (96). What effect, if any, this may have played in the case cited above (95) is unknown.

Since most radiotracers must cross biological membranes sometime during their biodistribution, a consideration of pharmacological membrane alterations seems appropriate.

Calcium is intimately involved in many aspects of cellular metabolism including glycolysis, mitochondrial metabolism, junctional communication between cells, cell proliferation, cell adhesion, and numerous other processes. Calcium can induce major structural changes in model lipid bilayers (97).

Primary interactions of calcium with phospholipids result in secondary effects on proteins embedded in the lipid phase of biological membranes. In general, absorption of Ca^{+2} and other bivalent cations to negatively charged bilayers reduces the surface charge, "stabilizes" the membrane, reduces its fluidity, and decreases its permeability. In membranes of mixed phospholipids, however, Ca^{+2} can induce phase separation and formation of solid phospholipid islets at the interface between fluid and solid phases (98).

Evidence strongly suggests that psychotropic drugs induce a variety of alterations in membrane transport mechanisms. These drugs inter-

act with the sodium pump, the cyclic nucleotide system, microtubules, and membrane calcium (99).

It has been demonstrated that local anesthetics and tranquilizers such as chlorpromazine cause a dramatic decrease in the ATP content of chicken erythrocytes which is accompanied by an increase in membrane particle aggregation and exposure of membrane phospholipids (100). As noted previously, Ca^{+2} may interact with membrane phospholipid. In addition, arachidonic acid is produced from membrane phospholipid. Arachidonic acid is converted to prostaglandin endoperoxides PGG_2 , PGH_2 , and thromboxane A_2 . These agents can cause platelet sensitivity to aggregation and the release of granule contents. Increased platelet sensitivity to aggregation by collagen has been described in a variety of altered physiological states, suggesting the possibility of platelet participation in uptake in bone associated with collagen (70).

[^{67}Ga]Gallium Citrate

After intravenous injection, ^{67}Ga is associated with transferrin. Subsequent tissue localization may occur as a result of migration of gallium from transferrin to other metal-binding molecules, such as lactoferrin which is similar to transferrin in molecular weight but differs in tissue distribution. Tissues and secretions with high lactoferrin content are known to concentrate gallium (101). These include neutrophilic leukocytes, bone marrow, colon, tears, and genital, salivary, and nasopharyngeal secretions (102). Increased lactoferrin is seen in breast tumors and in the spleen of patients with Hodgkin's disease. In inflammatory lesions, lactoferrin is deposited by PMN leukocytes and binds to the surface of monocytes and macrophages where it appears to inhibit bacterial growth by removing available ferric ion needed by the invading organisms (101).

Estrogen-stimulated plasma proteins are transport proteins responsible for small molecules such as steroids, thyroid hormones, and metals. Ceruloplasmin and transferrin are increased by estrogen (102).

Observation of gallium activity within neutrophils of inflammatory lesions suggests the possibility of a common mechanism of uptake

and/or intracellular binding of gallium by neoplastic and inflammatory cells (103).

Several factors may influence leukocyte function. The clinical significance of these influences is only speculative; the controversy as to the physiological behavior of gallium, however, may be rooted in the effects of such outside influences on neutrophils. For instance, activation of oxidative metabolism in PMN leukocytes results in increased oxygen consumption, glucose oxidation, and generation of oxidative intermediates (superoxide anion, hydrogen peroxide, and hydroxyl radical). This oxidation "burst" can be stimulated by opsonized particles or concanavalin A (con A), cytochalasin E, and the calcium ionophore A23187. The absence of oxidative intermediates is associated with depressed microbicidal activity (104). False negative [^{67}Ga]gallium citrate scans may occur in chronic abscess in leukopenic patients (105, 106).

Other studies suggest that gallium associates primarily and tenaciously with the plasma membranes of lymphocytes and that uptake appears to be associated with changes in the plasma membrane, such as those that occur in phytohemagglutinin-stimulated cells. Lymphocytes are known to be abnormal in lymphomas which accumulate gallium avidly. T-lymphocytes are able to be transformed readily with mitogens. The degree of uptake of gallium was not associated with any aspect of cell division but rather with some aspect of the cell membrane which is known to be different in normal and neoplastic tissues. Support for plasma membrane localization is provided by the observation that 50% of the gallium can be digested from the cell by proteolytic enzymes without incurrence of lethal cell damage (107). Other studies, in contrast to the previously mentioned observation, indicate that chronic lymphocytic leukemia in a patient with enlarged lymph nodes failed to yield a positive scan (103).

Lymphocyte activation by mitogens such as con A and cytochalasin E appears to be dependent on calcium influx via endogenous calcium ionophores that act as a signal for cyclic nucleotides to trigger cell proliferation; therefore, agents that increase cellular levels of cyclic guanosine monophosphate (cGMP) promote pro-

liferation and secretory function of lymphocytes. Agents that increase cAMP decrease this function. The transfer of Ca^{+2} into lymphocytes by A23187 bypasses physiologic membrane events, resulting in proliferation of normal human lymphocytes (108). There are other pathways for A23187 action. A23187 can stimulate the movement of Mg^{+2} and K^{+} in mitochondria and induces a Ca^{+2} influx and concurrent hypopolarization of cell membrane. The latter effect is not solely due to Ca^{+2} movement, since measurements of Na^{+} , K^{+} , and PO_4^{-3} indicate that A23187 also alters the fluxes of these ions across the membrane (97). Entry of K^{+} into lymphocytes is one of the earliest events of lymphocyte activation (109). Parallel experiments with con A reveal a similar redistribution of Na^{+} , K^{+} , PO_4^{-3} , and Ca^{+2} (97). Levamisole is an anthelmintic, immunostimulating drug capable of altering intracellular levels of cyclic nucleotides, which modulates lymphocyte activation. It is known to enhance catabolism of cAMP and to inhibit the catabolism of cGMP which is implicated in lymphocyte activation (108).

Acidosis, ketosis, and hyperlipidemia may act together or independently to alter lymphocyte membrane or the internal metabolism of lymphocytes, resulting in depressed reaction to mitogens, impaired bactericidal capacity, and impaired local exudative cellular response (110).

Suppression of K^{+} entry into lymphocytes by ouabain will prevent mitosis, blastogenesis, and increased protein DNA and RNA synthesis. Humans receiving 60 mg of prednisone develop lymphopenia within a few hours. Lymphocytes obtained after drug administration respond poorly to mitogens. Either circulatory lymphocytes are being inactivated by the corticosteroid, or those lymphocytes that respond well to mitogen have been sequestered outside of the circulation. This sequestration prevents migration into areas of immunologic challenge (109).

Some studies suggest that gallium localizes in subcellular organelles morphologically identifiable as lysosomes, phagolysosomes, or related particles. Recently, electron microscopic autoradiography has shown ^{67}Ga to be associated with lysosomes (111).

Certain moieties known as lysosomotropic agents are known to be taken up selectively into lysosomes. The antimalarial drug chloroquine can reach such concentration in lysosomes that it may seriously affect the activity of some of the lysosomal enzymes and thus impair lysosomal digestion. Chloroquine has been known to inhibit the breakdown of endogenous proteins and mucopolysaccharides in fibroblasts and that of exogenous proteins in macrophages. Dextran, a polysaccharide, also accumulates in lysosomes. Dextran has a toxicity that may be related to its accumulation and very slow clearance from lysosomes.

Agents entering lysosomes can act by modifying the properties of the lysosomal membrane and thus increasing or decreasing its ability to contain lysosomal digestion. Anti-inflammatory agents such as cortisone exert their effect, at least partly, by modifying the lysosomal membrane, rendering it less fragile and perhaps less capable of fusing with plasma membranes to allow exocytic discharge of the lysosome contents. Investigators have extracted a substance from kidney lysosomes with a strong affinity for cationic compounds which could account for kidney binding of [^{67}Ga]gallium citrate. Carrageenan, used as a food emulsifier, and polyvinylpyrrolidone are also known to be stored in lysosomes (112).

In contrast to the lysosomal localization mechanism, another set of ultracentrifugation studies showed gallium in tumor tissue to be located in the nuclei fraction (113). More recently, researchers have demonstrated activity in organelles that are smaller than lysosomes. These granules were isolated with use of a different homogenization process. Morphologically, these particles were predominantly rough-surfaced endoplasmic reticulum fragments; however, small single-membrane electron-dense granules also were present (114).

As has been observed earlier, high tissue prolactin levels have a potent influence on [^{67}Ga]gallium citrate accumulation in mammary and other tissues. Hyperprolactinemia can occur in pituitary adenomas, primary hypothyroidism, chest wall injuries, carcinoma of lung (which secretes ectopic prolactin), emotional and physical stress, and advanced renal failure

and may be induced by many drugs. Included among these are reserpine, methyl dopa, oral contraceptives, antidepressants, and phenothiazines (115).

In the use of [^{67}Ga]gallium citrate for brain tumor scanning, pretreatment with anti-inflammatory steroids showed either a disappearance or a reduction of gallium uptake (116).

Administration of iron dextran has been demonstrated to lower the whole-body retention in intact and abscess-bearing animals. When administered 24 hours after tracer injection, iron dextran decreases background activity, resulting in more apparent lesions. Thus, the kinetics of [^{67}Ga]gallium citrate distribution can be remarkably altered by administration of iron dextran which displaces the gallium from transferrin and other binding proteins and enhances gallium excretion, resulting in a high abscess-to-muscle ratio (117).

Ethanol and benzyl alcohol have been shown to produce a tenfold increase in cAMP in human leukocytes. Significant but less marked augmentation of cAMP was observed in human platelets and granulocytes. The mechanism is believed to be alcohol-induced membrane perturbation and activation of adenylyl cyclase. Parenteral drugs as well as bacteriostatic water and saline for injection, as diluents for parenteral drugs, often contain benzyl alcohol as a preservative. Although the amount of benzyl alcohol administered under normal circumstances is low, unusual therapies may result in a larger benzyl alcohol exposure. One example is that of "methotrexate rescue" therapy in which 100–150 ml of methotrexate with 0.9% benzyl alcohol can deliver 0.9–1.35 gm of preservative. Several processes important in inflammation and immunity are known to be suppressed by increases of intracellular cAMP: (a) lysosomal enzyme release from PMN leukocytes and macrophages, (b) histamine release from mast cells and basophilic leukocytes, (c) antibody-dependent lymphocyte-mediated cytotoxicity, (d) lymphocyte activation, (e) platelet aggregation, (f) PMN leukocyte and macrophage motility, and (g) PMN leukocyte adherence (118).

Use of oily lymphangiographic contrast material preceding total-body [^{67}Ga]gallium citrate

scanning has resulted in radionuclide accumulation in the lungs. Histologic changes in the lungs of animals and in the lymph nodes of humans following contrast lymphangiography have been reported, suggesting the possibility of irritant effects of contrast material on pulmonary parenchyma as a cause for lung uptake (119).

There is much controversy as to the actual mechanism of uptake of [^{67}Ga]gallium citrate into cells, and it has been suggested that with elucidation of the exact mechanism we may identify a set of processes of major biological importance. Similar cellular entry pathways are suspected for ^{111}In , the rare earth elements, and the actinides—all of which show considerable similarities to ^{67}Ga in their biological behavior (111).

Use of agents such as the mitogens, con A and cytochalasin B or calcium ionophore A23187 provide a model for the better understanding of drug interferences with radiotracers.

Nuclear Cardiology

Three categories of nuclear imaging used for noninvasive evaluation of coronary heart disease have been described: (a) study of regional perfusion can be used to detect either fixed alterations in blood flow caused by infarction and cardiomyopathy or transient changes in perfusion when the tracer is administered at the time of transient ischemia; (b) the total and regional function of both right and left ventricles can be evaluated with tracers which reside in the blood pool of the heart, either from activity curves recorded during the initial passage through the heart or from gated images of the heart at end systole and end diastole; (c) acutely damaged muscle can be evaluated with agents that concentrate in zones of acute severe injury (120).

Three sequential processes are required for cellular localization of tracers. First, some perfusion must be present in the vicinity of the target site to transport the tracer from its injection site; second, the tracer must be able to diffuse from the intravascular space through the interstitial space to the site of localization; and third, the tracer should become fixed at the target site. In myocardial infarction (MI) the

target usually is dead or dying myocardial cells but could be interstitial substance or another cell type, such as granulocyte or fibroblast (121).

That several chelate complexes show localization in all infarcted or necrotic tissue of varied pathogenesis suggests that the concentration process is mediated by influx into the damaged area due to increased vascular permeability, followed by binding to damaged components (122).

An essential step in the identification of potential effects of drugs on uptake in myocardial tissue is an understanding of the biochemical adaptations of hypoxic and otherwise stressed cells as well as a better understanding of the biochemical changes induced by cardioactive drugs. For example, the inotropic effect of digitalis on cardiac muscle can be attributed to its action on the sarcolemma cell membrane to stimulate Ca^{+2} influx, thus providing a greater quantity of Ca^{+2} to contractile proteins, resulting in a more forceful contraction. It is believed that digitalis binds to specific sarcolemma-tubule system receptors thought to be $\text{Na}^{+}\text{-K}^{+}$ ATPase. This system is coupled with a $\text{Na}^{+}\text{-Ca}^{+2}$ exchange system which transports Na^{+} out of the cell in exchange for Ca^{+2} brought into the cell. When digitalis interferes with $\text{Na}^{+}\text{-K}^{+}$ ATPase, there is an increase in intracellular Na^{+} which activates the $\text{Na}^{+}\text{-Ca}^{+2}$ exchange system with augmentation of Ca^{+2} influx to contractile protein (123).

It has been demonstrated that in digitalized animals, the ^{43}K myocardium-to-blood (M/B) ratio was enhanced due to slower myocardial clearance after digoxin. Administration of isoproterenol prior to ^{43}K injection reduced myocardial clearance. Although the initial myocardial concentration was lower, the slower washout resulted in higher M/B ratios (124).

cAMP is thought to play an important role in cardiac function. Increased concentration of cAMP within cells appears to accelerate Ca^{+2} inflow, causing an inotropic effect on ischemic cells and increasing oxygen demand in face of a limited supply during ischemic disease. A metabolic gradient between ischemic and non-ischemic zones would increase. During ischemia, cAMP would accelerate glycogenolysis to an extent related to the severity of ischemia.

Hydrogen ion accumulation is one important end result of glycogenolysis in ischemic tissue which aggravates cell damage. cAMP also accelerates lipolysis, resulting in accumulation of acetyl coenzyme A which blocks energy transfer from mitochondria to cytoplasm. Agents that inhibit cAMP accumulation such as β -adrenergic blockers and agents which promote intracellular destruction of cAMP may prevent metabolic alteration in ischemic tissue (125).

cAMP plays a role in the modulating effect of cardioactive drugs. Potent stimulators of adenylyl cyclase and inhibitors of phosphodiesterase are cardiostimulant agents. The biological effects of cAMP are associated with the activation of cAMP-dependent protein kinases which phosphorylate a number of substrates. There is a β -receptor-adenylyl cyclase complex that can act as a mediator for some cardiostimulant drugs. The sarcoplasmic reticulum (SR) may function as a receptor for cAMP-dependent functions. Canine SR fractions respond to cAMP, epinephrine, and glucagon with augmentation of Ca^{+2} uptake. Protein kinase was needed for this effect to be observed. Further evidence suggests a link between intermediary metabolism and excitation-contraction coupling. Ischemic events or sympathetic stress may alter intermediary metabolism and SR glycogen concentration with a direct effect on SR Ca^{+2} accumulation or release through alterations in membrane structure or by affecting the kinetics of cardiac enzymes (126).

Methylprednisolone has been shown to accelerate pyrophosphate blood clearance, thus lowering blood and normal myocardial pyrophosphate levels (127).

The anthracycline antibiotics, such as doxorubicin, are widely used as anticancer agents. Use of these agents tends to result in serious myocardial damage (128), including pericardial effusion, subpericardial edema, myocarditis, cytoplasmic vacuolization, and nuclear changes in rabbits within 24 hours of administration of 20 mg doxorubicin per kg (129). Abnormal $^{99\text{m}}\text{Tc}$ -PYP accumulation has been observed in patients undergoing treatment for neoplasia with this drug (128).

The cardiotoxic effects of the anthracycline agents are enhanced by prior irradiation of the

precordium. Doxorubicin is known to aggravate radiation-induced heart disease, resulting in myocardial damage at lower doses of radiation (128). It is noteworthy that doxorubicin is known to induce peroxidation of cardiac lipids by the formation of free radicals (130). Free radical-lipid peroxidation occurs under a variety of circumstances, including vitamin E deficiency, intoxication with carbon tetrachloride, exposure to ionizing radiation, carcinogenesis, the aging process and, possibly, hyperlipidemia accompanying atherosclerosis (131). Peroxidation is also observed in degranulation of leukocytes and platelets, as has been noted previously.

^{201}Tl often is referred to as a potassium analog because the monovalent Tl^+ ion can substitute for potassium on the $\text{Na}^+\text{-K}^+$ transmembrane exchange system (132). The extraction of Tl^+ by the myocardium is probably due to activation of the $\text{Na}^+\text{-K}^+$ ATPase system in which Tl appears to bind to two sites on the enzyme whereas K binds to one site. This binding may account for the prolonged clearance of Tl rather than K from the myocardium (133). Thus, ^{201}Tl can replace potassium in the activation of pyruvate kinase and $\text{Na}^+\text{-K}^+$ ATPase (134).

^{201}Tl transport is facilitated by depolarization and repolarization of the myocardial cell membrane. During each beat of the normal aerobic contraction, about 3% of the intracellular K^+ is exchanged for extracellular K^+ and Tl^+ . With anaerobic metabolism, there is little or no Tl^+ incorporated into the cell despite high flow rate (135).

The ability of ions to pass through membranes is associated with their crystal radius, while their mobility in solution is associated with their hydrated radius (136). The rate of passive influx into erythrocytes has been shown to increase with increasing pH. The erythrocyte membrane barrier to Tl^+ contains positively charged R-NH_3^+ groups capable of repelling cations. An increase in pH could be expected to decrease the number of positive charges in the barrier and perhaps facilitate cation penetration in both directions (137).

Part of the observed differences between the behavior of Tl^+ and K^+ can perhaps be ex-

plained by the fact that Tl^+ , unlike the alkali metal cations, possesses 6S electrons and is capable of more appreciable association with anions and of complex formation (137).

Tl^+ influx across erythrocyte membranes can be explained by a model consisting of two components: a saturable ouabain-sensitive "active" influx and a ouabain-insensitive "passive" influx that is much less saturable and is not influenced by potassium concentration (137).

Since myocardial uptake of ^{201}Tl appears to be dependent on both blood flow and cellular ion transport, assessment of the effect of drugs commonly used by cardiac patients on the distribution of Tl^+ is important (138).

In animal models of both ischemia and infarction, levels of radioactive potassium and thallium uptake have correlated well with microsphere estimates of regional myocardial blood flow in exercise imaging. Under circumstances of increased flow such as reactive hyperemia, cation uptake will be substantially less than that expected from microsphere flow estimates. Under other circumstances, extracted cations can be significantly altered while flow remains unchanged. Thus, alterations in intracellular active transport of cations due to altered cell membrane-enzyme function must be considered. Studies with canine gracilis muscle demonstrated that administration of propranolol reduces muscle uptake of radiopotassium and thallium by 2–2½ times normal. This alteration in cation uptake can be reversed by administration of isoproterenol. This phenomenon is independent of local blood flow or force of contraction and appears to represent an alteration in local intrinsic membrane function. If this same behavior occurs in cardiac muscle, it could limit the usefulness in quantitative imaging of myocardial distribution of these radionuclides (139).

A study has been performed to assess the effects of drugs such as dipyridamole, digoxin, furosemide, and propranolol on myocardial distribution of ^{201}Tl in cardiac patients. Of these drugs, only dipyridamole showed a marked increase in myocardial uptake of ^{201}Tl , possibly due to increased blood flow in the coronary arteries to 3–4 times the resting level; however, the increased localization was not associated with myocardial blood flow in a linear manner

(138). In addition to its vasodilatory effect, dipyridamole is a phosphodiesterase inhibitor and potentiates endogenous prostacyclin (PGI_2) resulting in antithrombotic activity (74). PGI_2 is the major product of arachidonic acid in the walls of the arteries and veins of humans (140). Whether this effect of dipyridamole is responsible for the observed alteration of ^{201}Tl uptake is open to speculation.

In the same study, propranolol altered distribution to a statistically significant degree but resulted in only minor change to the myocardial image. It should be noted, however, that this study was performed on resting animals without coronary artery disease. Propranolol may alter regional blood flow during exercise and decrease myocardial oxygen consumption for a given level of exertion. Either one of these factors could change the regional distribution of ^{201}Tl in the exercising human with coronary disease (138).

If, as was suggested (138), Tl^+ can activate $\text{Na}^+\text{-K}^+$ ATPase, competitive inhibitors of this enzyme system would be expected to decrease the participation of Tl^+ in the enzyme system.

Sodium bicarbonate has been used to enhance the myocardial concentration of ^{201}Tl in rabbits and dogs, resulting in an increase in myocardial uptake of 1½–2 times that observed without use of sodium bicarbonate. This change in uptake occurred with an arterial pH change of only 0.1 U (141).

Insulin and 20% glucose given with radioactive potassium, rubidium, and cesium results in a significant increase in myocardial uptake of these radionuclides and also prolongs the myocardial half-life of ^{131}I -labeled oleic acid. Insulin in hypertonic glucose has been used clinically to alter the extracellular-to-intracellular potassium distribution in patients and to ameliorate the effects of ischemic myocardium. There is evidence that the combination of hypertonic glucose and insulin play independent roles in altering K^+ distribution. Rapid injection of 20% glucose can quickly lower circulating K^+ levels and has a direct effect on transmembrane potential. Insulin may alter myocardial ion transport and does enhance inorganic phosphate uptake in the liver, which may be accompanied by intracellular K^+ migration (124).

Increased endogenous TSH induced by propylthiouracil (PTU) resulted in a significant rise in the thyroid-to-serum ratio for ^{201}Tl , while TSH inhibition with 1-thyroxine resulted in a decrease in the ratio (142).

Thyroid-scanning Agents

Thyroid-scanning agents can be used for determination of thyroid size as well as for functional assessment of thyroid nodules. Pertechnetate, sodium [^{131}I]iodide, and sodium [^{123}I]iodide are the primary tracers used in thyroid function studies and diagnosis. Since most of the influence of pharmacologic agents on pertechnetate are discussed earlier, this section deals with iodine radiotracers.

Usually, diagnostic procedures in which radionuclides are used give an accurate picture of the thyroid gland and the extent of the pathology. Anything that interferes with the uptake of the iodine or blocks its release from the thyroid, however, gives a false indication. Several drugs, some of which are used daily by diabetics, epileptics, and allergy sufferers, have a propensity for obscuring these thyroid tests. Other drugs are iodine-containing contrast media, anti-thyroid medications, and thyroid supplements (143).

It might be expected that any pharmacologic agent that affects thyroid function might alter the uptake of thyroid-scanning agents. Thus, antithyroid drugs such as methimazole and PTU would invalidate measurements of radioiodine uptake (144). Administration of phenylbutazone results in a reduction of sodium [^{131}I]iodide uptake by induction of a temporary partial suppression of TSH. This suppression subsides as treatment continues (145). Other nonsteroidal anti-inflammatory agents may be suspect. It has been reported that morphine interferes with TSH (146). Results of studies suggest that antihistamines reduce ^{131}I uptake in euthyroid patients by 50% (147). In humans, ACTH and cortisone diminish the thyroidal accumulation of ^{131}I . These hormones abruptly diminish the protein-bound iodide (PBI), but they do not alter the turnover of thyroxine in peripheral tissues (148).

A variety of drugs including sulfonamides, sulfonyleureas, *p*-aminosalicylate (PAS), *p*-ami-

nobenzoic acid (PABA), and resorcinol are known to bind active iodide formed in the thyroid gland (146). Tolbutamide, a sulfonylurea hypoglycemic agent, produces a mild but definite inhibition of ^{131}I uptake (149). Glucocorticoids, such as dexamethasone, reduce plasma TSH concentrations with expected effects on the thyroid (150).

Drugs containing iodides interfere with the entry of inorganic iodide into the thyroid. A wide variety of pharmaceuticals contain iodide. These include expectorants, some vaginal suppositories, and iopanoic acid used for cholecystography. Other dyes used for radiodiagnostic purposes contain iodide (151).

Heavy metals (152) and some antibiotics, especially penicillin, chlortetracycline, and chloramphenicol, are capable of inhibition of ^{131}I uptake (143).

A summary of some of the agents that are known to influence ^{131}I uptake in the thyroid is given in Chapter 14.

Hepatobiliary Scanning Agents

Although most nuclear medicine hepatobiliary studies are performed with use of $^{99\text{m}}\text{Tc}$ -iminodiacetic acid analogs, another cholescintigraphic agent that has been used is $^{99\text{m}}\text{Tc}$ -penicillamine (153). Penicillamine is so named because it is a degradation product of penicillin and is prepared by hydrolysis of penicillin. Probenecid is known to completely block the renal tubular secretory transport of penicillin (67). Whether this same mechanism would be applicable to the tracer levels used for scanning purposes. It has been suggested, however, that at least in the therapeutic use of penicillamine, concomitant use of probenecid should be avoided if possible (154).

Therapeutic doses of morphine, codeine, and other morphine surrogates can cause marked increase in biliary tract pressure. For example, after subcutaneous administration of 10 mg of morphine sulfate, the pressure in the common bile duct rises from the normal of less than 20 mm of water to a level of 200–300 mm. The response begins within 5 minutes after injection, reaches its peak in 15 minutes and persists for 2 hours or more. This is due to a sharp

constriction at the lower end of the common bile duct (sphincter of Oddi). The spasm prevents emptying and thus causes the intraductal pressure to rise (67). This interaction is discussed further in Chapter 14.

SUMMARY

The mechanisms by which drugs affect radiopharmaceutical biodistribution are often mediated through changes in cell membrane characteristics, interactions with blood cellular components, or alteration of enzyme-controlled functions. Although this chapter has presented some of the possible ways that drugs may modify the biorouting of certain radiotracers, considerable research still needs to be performed to confirm these mechanisms and to elucidate further information on the subject. In particular, research in which chemical agents such as con A, cytochalasin E, and A23187 are used for pharmacological dissection of cells could be of help in identifying the precise mechanisms of radiotracer localization. At the same time, attention to reports of suspected alterations of tracer behavior in the presence of drugs, combined with a detailed knowledge of the pharmacology of such drugs, constitutes a valuable source of new knowledge about tracer behavior.

The next few years will see some breakthroughs in understanding the mechanisms of uptake of radiotracers. This understanding, when achieved, will open the door to future applications of radionuclides in diagnosis and organ function and will elucidate some of the complex biochemical interactions about which we can merely speculate at the present time.

REFERENCES

- Hayes MT, Green FA: In vitro studies of $^{99\text{m}}\text{Tc}$ pertechnetate binding by human serum and tissues. *Nucl Med* 14:149, 1973.
- Socolow EL, Ingbar SH: Metabolism of $^{99\text{m}}\text{Tc}$ pertechnetate by the thyroid gland of the rat. *Endocrinology* 80:337, 1967.
- Harden R, Hilditch TE, Kennedy I, et al: Uptake and scanning of the salivary glands in man using pertechnetate- $^{99\text{m}}\text{Tc}$. *Clin Sci* 32:39, 1967.
- Van den Akker HP, Sokole, EB, Vanderschoot, JB: Origin and location of the oral activity in sequential salivary gland scintigraphy with $^{99\text{m}}\text{Tc}$ -pertechnetate. *J Nucl Med* 17:959, 1976.

- Lathrop KA, Harper PV: Biologic behavior of $^{99\text{m}}\text{Tc}$ from $^{99\text{m}}\text{Tc}$ -pertechnetate ion. *Prog Nucl Med* 1:146, 1972.
- Lathrop KA, Harper PV: Quantitation of $^{99\text{m}}\text{Tc}$ localization in stomach and intestine after intravenous administration of $\text{Na}^{99\text{m}}\text{TcO}_4$ in humans. *J Nucl Med* 9:332, 1968.
- Dayton DA, Maher FT, Elveback LR: Renal clearance of technetium ($^{99\text{m}}\text{Tc}$) as pertechnetate. *Mayo Clin Proc* 44:459, 1969.
- Hayes M, Derman M: Pertechnetate distribution in man after intravenous infusion; a compartmental model. *J Nucl Med* 18:898, 1977.
- Castronovo FP, Potsaid MS: A need for the standardization of methods for reporting clinical radiopharmaceutical data. *J Nucl Med* 18:855, 1977.
- Winchell HS: Mechanisms for localization of radiopharmaceuticals in neoplasms. *Semin Nucl Med* 6:371, 1976.
- Davis MA, Holman BL, Carmel AN: Evaluation of radiopharmaceuticals sequestered by acutely damaged myocardium. *J Nucl Med* 17:911, 1976.
- Gringauz A: Selected classes of drugs—how do they work? *US Pharm* 4:55, 1979.
- Bunce GE, Li BW: A study of calcium pump activity of lysosomes from rat renal cortex. *Biochim Biophys Acta* 250:163, 1977.
- Vera DR, Krohn KA, Stadalnik RQ: Radioligands that bind to cell-specific receptors; Asialoglycoproteins for hepatic scintigraphy. *Am J Roentgenol* 132:492, 1979.
- Cuthbert AW: Membrane lipids and drug action. *Pharmacol Rev* 19:59, 1967.
- Michell RH: Inositol phospholipids and cell surface receptor function. *Biochim Biophys Acta* 415:81, 1975.
- Riordan JR, Forstner GG: Glycoprotein membrane enzymes. In Bronner F, Kleinzeller A (eds): *Current Topics in Membranes and Transport*, Vol II. *Cell Surfaces Glycoproteins; Structure, Biosynthesis and Biological Functions*. New York, Academic Press, 1978, p 246.
- Lauf K: Antigen-antibody reactions and cation transport in biomembranes; immunophysiological aspects. *Biochim Biophys Acta* 415:173, 1975.
- Loh HH, Law PY: The role of membrane lipids in receptor mechanisms. *Ann Rev Pharmacol Toxicol* 20:201, 1980.
- Eisenberg M, Kleinberg ME, Shaper JH: Channels across black lipid membranes. In Takashima S, Fishman HM (eds): *Proceedings, Electrical Properties of Biological Polymers, Water and Membranes Conference*, January 26–28, 1977. New York, New York Academy of Science, vol 303, 1977, p 281.
- Seeman P: The membrane actions of anesthetics and tranquilizers. *Pharmacol Rev* 24:583, 1972.
- Lee AG: Local anesthesia; the interaction between phospholipids and chlorpromazine, propranolol and practolol. *Mol Pharmacol* 13:474, 1977.
- Deleted in proof.
- Papahadjopoulos D, Vail WJ, Newton C, et al: Studies on membrane fusion. III. The role of calcium-induced phase changes. *Biochim Biophys Acta* 467:579, 1977.
- Rimon G, Hanski E, Braun S, Levitzki A: Mode of coupling between hormone receptors and adenylate cyclase elucidated by modulation of membrane fluidity. *Nature* 276:394, 1978.
- O'Flaherty JT, Showell HJ, Becker EL, Ward, PA: Substances which aggregate neutrophils. *Am J Pathol* 92:155, 1978.
- Rubin RP, Laychock SG: Prostaglandins and calcium-membrane interactions in secretory glands. *Ann NY Acad Sci* 307:377, 1978.
- Schulz I, Heil K: Ca^{2+} control of electrolyte permeability in plasma membrane vesicles from cat pancreas. *J Membr Biol* 46:41, 1979.
- Middleton E: Antihistaminic drug therapy and calcium ions: a review of pathogenesis and role of calcium. *J Pharm Sci* 69:243, 1980.
- Pollet RJ, Levey GS: Principles of membrane receptor physiology and their application to clinical medicine. *Ann Intern Med* 92:663, 1980.
- Fry DW, White JC, Goldman ID: Alterations of the carrier-mediated transport of an anionic solute, methotrexate, by charged liposomes in Ehrlich ascites tumor cells. *J Membr Biol* 50:123, 1979.
- Khettery J, Effman E, Grand RJ, Treves S: Effect of pentagastrin, histalog, glucagon, secretin and perchlorate on the gastric handling of $^{99\text{m}}\text{Tc}$ pertechnetate in mice. *Radiology* 120:629, 1976.
- Harper PV, Lathrop KA, Gottschalk A: Pharmacodynamics of some technetium- $^{99\text{m}}\text{Tc}$ preparations. In Andrews GA, Kniseley RM, Wagner HN (eds): *Radioactive Pharmaceuticals*. Oak Ridge, TN, US Atomic Energy Commission, 1966, p 335.
- Holmes RA, Luth CN: Glycocyrrholate in $^{99\text{m}}\text{Tc}$ -pertechnetate brain imaging. *J Nucl Med* 16:819, 1975.
- Konikowski T, Haynie TP: The effect of pertechnetate on the localization of $^{99\text{m}}\text{Tc}$ -pertechnetate in a mouse sarcoma. *J Nucl Med* 11:443, 1970.
- Oldendorf WH, Sisson WB, Iisaka Y: Affect of perchlorate ion on distribution of $^{99\text{m}}\text{TcO}_4$ to plasma binding. *J Nucl Med* 11:85, 1970.
- Matin P: *Handbook of Clinical Nuclear Medicine*. New Hyde Park, NY, Medical Examination Publishing Company, 1977.
- Penning L, Front D, Bechar M, et al: Factors governing the uptake of pertechnetate by human brain tumors. *Brain* 96:225, 1973.
- Crocker EF, Zimmerman RA, Phelps ME, Kuhl DE: The effect of steroids on the extravascular distribution of radiographic contrast material and technetium pertechnetate in brain tumors as determined by computed tomography. *Radiology* 119:471, 1976.
- Marty R, Cain ML: Effects on corticosteroid (dexamethasone) administration of the brain scan. *Radiology* 107:117, 1973.
- Stebner FC: Steroid effect on the brain scan in a patient with cerebral metastases. *J Nucl Med* 16:320, 1975.

42. Joo F: Effect of N₆O₂-dibutyryl cycle 3'5' adenosine monophosphate on the pinocytosis of brain capillaries of mice. *Experientia* 28:1470, 1972.
43. Joo F, Rakonozay Z, Wollemann M: cAMP-mediated regulation of the permeability in the brain capillaries. *Experientia* 31:582, 1975.
44. Brightman MW, Klatzo I, Olsson Y, Reese TS: The blood-brain barrier to proteins under normal and pathological conditions. *J Neurol Sci* 10:215, 1970.
45. Petito CK, Schafer JA, Plum F: Ultrastructural characteristics of the brain and blood-brain barrier in experimental seizures. *Brain Res* 127:251, 1977.
46. Wang TST, Fawwaz RA, Esser PD, Johnson PM: Altered body distribution of 99mTc pertechnetate in iatrogenic hyperalbuminemia. *J Nucl Med* 19:381, 1978.
47. Rozas VV, Port RK, Ruit WM: Progressive dialysis encephalopathy from dialysate aluminum. *Arch Intern Med* 138:1375, 1978.
48. Rosenthal L, Stratford J: Observation of the effect of contrast material on normal and abnormal brain tissue using radiopharmaceuticals. *Radiology* 92:1467, 1969.
49. VanArsdel PP Jr: The complex world of adverse reactions. *Am J Roentgenol* 132:309, 1979.
50. Ancri D, Lonchamp M, Basset J: The effect of tin on the tissue distribution of 99mTc-sodium pertechnetate. *Radiology* 124:445, 1977.
51. Saba TM: Physiology and pathophysiology of the reticuloendothelial system. *Arch Intern Med* 126:1031, 1970.
52. Bergheim LE, Ahlgren LT, Grundfeldt MB, et al: Heparin-induced impairment of phagocytic and catabolic functions of the reticuloendothelial system in rats. *J Reticuloendothel Soc* 23:21, 1978.
53. Rhodes BA: Liposomes, and vesicles; a new class of radiopharmaceuticals? *J Nucl Med* 17:1102, 1976.
54. Schildt BE: The present view of RES and shock. *Adv Exp Med Biol* 73:375, 1976.
55. Blumenstock FA, Saba TM, Weber P: Purification of alpha-2-opsonic protein from human serum and its measurement by immunoassay. *J Reticuloendothel Soc* 23:119, 1978.
56. Klingensmith WC III, Tsan MF, Wagner Jr HN: Factors affecting the uptake of 99mTc-sulfur colloid by the lung and kidney. *J Nucl Med* 17:681, 1976.
57. Jacob HS: *Role of Complement and Granulocytes in Septic Shock*. Kalamazoo, MI, The Upjohn Company, 1978.
58. Craddock PR, Fehir J, Dalmasso AP, et al: Pulmonary vascular leukostasis resulting from complement activation by dialyzer cellophane membranes. *J Clin Invest* 59:879, 1977.
59. Zurier RB, Weissmann G, Hoffstein S, et al: Mechanisms of lysosomal enzyme release from human leukocytes. *J Clin Invest* 53:297, 1974.
60. Smith JW, Steiner AL, Parker CW: Human lymphocyte metabolism; effects of cyclic and concyclic nucleotides on stimulation by phytohemagglutinin. *J Clin Invest* 50:442, 1971.
61. Weissmann G, Dukor P, Zurier RB: Effect of cyclic AMP on release of lysosomal enzymes from phagocytes. *Nature New Biol* 231:131, 1971.
62. Ward PA: The chemosuppression of chemotaxis. *J Exp Med* 124:209, 1966.
63. Loose LD, DiLuzio NR: Dose-related reticuloendothelial system stimulation by diethylstilbestrol. *J Reticuloendothel Soc* 20:457, 1976.
64. Morgan TO: Diuretics: basic clinical pharmacology and therapeutic use. *Drugs* 15:151, 1978.
65. Shook DR, Shafer RB: Renal uptake of 99mTc-sulfur colloid. *Clin Nucl Med* 1:223, 1976.
66. Kim YC, Massari PU, Brown ML, et al: Clinical significance of 99mTc technetium sulfur colloid accumulation in renal transplant patients. *Radiology* 124:745, 1977.
67. Goodman LS, Gilman A: *The Pharmacological Basis of Therapeutics*, ed 4. New York, Macmillan, 1970, pp 16, 17, 246, 363, 888, 953, 1285, 1383.
68. Weiss HI: Platelet physiology and abnormalities of platelet function—part one. *N Engl J Med* 293: 531, 1975.
69. Weiss HI, Platelet physiology and abnormalities of platelet function—part two. *N Engl J Med* 293:580, 1976.
70. Mustard JF, Packman MA: Platelets and diabetes mellitus. *N Engl J Med* 297:1345, 1977.
71. O'Grady J, Moncada S: Aspirin: a paradoxical effect on bleeding time. *Lancet* 2:780, 1970.
72. Vane JR: The mode of action of aspirin and similar compounds. *Hosp Formul* 11:618, 1976.
73. Stuart MJ, Gerrard JM, White JG: Effect of cholesterol on production of thromboxane B₂ by platelets in vitro. *N Engl J Med* 302:6, 1980.
74. Korb R: Dipyridamole and other phosphodiesterase inhibitors act as antithrombotic agents by potentiating endogenous prostacyclin. *Lancet* 1:1286, 1978.
75. Russell RGG, Fleisch H: Pyrophosphate and diphosphonates in skeletal metabolism. *Clin Orthop* 108:241, 1975.
76. Ali SY, Evans L: The uptake of (⁴⁵Ca)calcium ions by matrix vesicles isolated from calcifying cartilage. *Biochem J* 134:647, 1973.
77. Charkes ND: Mechanisms of skeletal tracer uptake. *J Nucl Med* 20:794, 1979.
78. Eilon G, Raisz LG: Comparison of the effects of stimulators and inhibitors of resorption on the release of lysosomal enzymes and radioactive calcium from fetal bone in organ culture. *Endocrinology* 103:1969, 1978.
79. Waxman AD, Ducker S, McKee D, et al: Evaluation of 99mTc diphosphonate kinetics and bone scans in patients with Paget's disease before and after calcitonin treatment. *Radiology* 125:761, 1977.
80. Gray TK, Brannan P, Morawski SG, Fordtran JS: Ion transport changes during calcitonin-induced intestinal secretion in man. *Gastroenterology* 71:392, 1976.
81. Carr EAF Jr, Carroll M, Montes M: The use of adjunctive drugs to alter uptake of 99mTc-Sn-pyrophosphate by myocardial lesions and bone. *Life Sci* 22:1261, 1978.
82. Wahner HW, Dewanee MK: Teaching editorial. drug-induced modulation of Tc99m pyrophosphate tissue distribution. What is involved? *J Nucl Med* 22:555, 1981.
83. Carr EA Jr, Carroll M, Montes M: Effect of Vitamin D₃, other drugs altering serum calcium or phosphorus concentrations, and desoxycorticosterone on the distribution of Tc99m pyrophosphate between target and nontarget tissue. *J Nucl Med* 22:526, 1981.
84. Oster ZH, Som P, Sacker DF, Atkins HL: The effects of deferoxamine mesylate on gallium-67 distribution in normal and abscess-bearing animals; concise communication. *J Nucl Med* 21:421, 1980.
85. Hayes RL, Byrd BL, Rafter JJ, Carlton JE: The effect of scandium on the tissue distribution of Ga-67 in normal and tumor-bearing rodents. *J Nucl Med* 21:361, 1980.
86. Maublant J, Gachon P, Moins N, et al: Myocardial imaging in dogs with thallium-201 and the ionophore grisorixin. *J Nucl Med* 21:787, 1980.
87. Krishnamurthy GT, Bland WH, Brickman AS: Technetium-99mTc-Sn-pyrophosphate pharmacokinetics and bone image changes in parathyroid disease. *J Nucl Med* 18:236, 1977.
88. McRae J, Hambright P, Bearden AJ: Chemistry of Tc99m tracers. II. In vitro conversion of tagged HEDP and pyrophosphate (bone seekers) into gluconate (renal agent). Effects of Ca and Fe(II) on in vivo distribution. *J Nucl Med* 17:208, 1976.
89. Byun HH, Rodman SG, Chung KE: Soft-tissue concentration of 99mTc-phosphates associated with injections of iron dextran complex. *J Nucl Med* 17:374, 1976.
90. VanAntwerp JD, Hall JN, O'Mara RE, Hilts SV: Bone scan abnormality produced by interaction of Tc99m diphosphonate with iron dextran (Imferon). *J Nucl Med* 16:577, 1975.
91. Parker JA, Jones AG, Davis MA, et al: Reduced uptake of bone-seeking radiopharmaceuticals related to iron excess. *Clin Nucl Med* 1:267, 1976.
92. Chaudhuri TK: Liver uptake of 99mTc-diphosphonate. *Radiology* 119:485, 1976.
93. Kaehny WD, Hegg AP, Alfrey AC: Gastrointestinal absorption of aluminum from aluminum-containing antacids. *N Engl J Med* 296:1389, 1977.
94. Chaudhuri TK: The effect of aluminum and pH on altered body distribution of 99mTc-EHDP. *Int J Nucl Med Biol* 3:37, 1976.
95. Saha GB, Herzberg DL, Boyd CM: Unusual in vivo distribution of 99mTc-diphosphonate. *Clin Nucl Med* 2:303, 1977.
96. Wiberg JJ, Turner GG, Nuttall FQ: Effect of phosphate or magnesium cathartics on serum calcium. *Arch Intern Med* 138:1114, 1978.
97. Mikkelsen RB: Calcium and neoplasia. *Prog Exp Tumor Res* 22:123, 1978.
98. Schulz I, Heil K: Ca²⁺ control of electrolyte permeability in plasma membrane vesicles from cat pancreas. *J Membr Biol* 46:41, 1979.
99. Grosso A, deSouza RC: Vasopressin-like effects of psychotropic drugs in amphibian epithelia. *J Membr Biol* 40:77, 1978.
100. Gazitt Y, Loyter A, Ohad, I: Induction ATP depletion, intramembrane particle aggregation and exposure of membrane phospholipids in chicken erythrocytes by local anesthetics and tranquilizers. *Biochim Biophys Acta* 471:361, 1977.
101. Hoffer PB, Miller-Catchpole R, Turner DA: Demonstration of lactoferrin in tumor tissue from two patients with positive gallium scans. *J Nucl Med* 18:713, 1977.
102. Lipsitt MB, Combs J, Catt K, et al: Problems in conception. NIH conference. *Ann Intern Med* 74:251, 1971.
103. Arseneau JC, Aamodt R, Johnston GS, Canellos GP: Evidence for granulocytic incorporation of gallium in chronic granulocytic leukemia. *J Lab Clin Med* 83:496, 1974.
104. Harvath L, Anderson BR: Defective initiation of oxidative metabolism in polymorphonuclear leukocytes. *N Engl J Med* 300:1130, 1979.
105. Habibian MR, Staab EV, Matthews HA: Gallium citrate Ga 67 scans in febrile patients. *JAMA* 233:1073, 1975.
106. Gelrud LG, Arseneau JC, Milder MS, et al: The kinetics of gallium incorporation into inflammatory lesions; experimental and clinical studies. *J Lab Clin Med* 83:489, 1974.
107. Merz T, Malmud L, McKusick K, Wagner Jr HN: The mechanism of ⁶⁷Ga association with lymphocytes. *Cancer Res* 34:2495, 1974.
108. Scheinberg MA, Santos L, Mendes NF, Musatti C: Decreased lymphocyte response to PHA, Con A, and calcium ionophore (A23187) in patients with RA and SLE and reversal with levamisole in rheumatoid arthritis. *Arthritis Rheum* 21:326, 1978.
109. Takyanyu D: Effect of corticosteroids on lymphocyte activation. *Blood* 49:873, 1977.
110. Speert DP, Silva J: Abnormalities of in vitro lymphocyte response to mitogens in diabetic children during acute ketoacidosis. *Am J Dis Child* 132: 1014, 1978.
111. Hayes RL: The tissue distribution of gallium radionuclides. *J Nucl Med* 18:740, 1977.
112. Duvi C, deBarys T, Poole B, et al: Commentary; lysosomotropic agents. *Biochem Pharmacol* 23:1495, 1974.
113. Clausen J, Edeling CJ, Fogh J: ⁶⁷Gallium binding to human serum proteins and tumor components. *Cancer Res* 34:1931, 1974.
114. Brown DH, Byrd BL, Carlton JE, et al: A quantitative study of the subcellular localization of ⁶⁷Ga. *Cancer Res* 36:956, 1976.
115. Stepanas AV, Maisey MN: Hyperprolactinaemia as a cause of gallium-67 uptake in the breast. *Br J Radiol* 49:379, 1976.
116. Waxman AD, Beldon JR, Richli WR, et al: Steroid induced suppression of gallium uptake in tumors of the central nervous system. *J Nucl Med* 18:617, 1977.
117. Oster ZH, Larson SM, Wagner Jr HN: Possible enhancement of ⁶⁷Ga-citrate imaging by iron dextran. *J Nucl Med* 17:356, 1976.
118. Atkinson JP, Sullivan TJ, Kelly JP, Parker CW: Stimulation by alcohols of cyclic AMP metabolism in

- human leukocytes. *J Clin Invest* 60:284, 1977.
119. Lentle BC, Castor WR, Khaliq A, Dierich H: The effect of contrast lymphangiography on localization of ^{67}Ga -citrate. *J Nucl Med* 16:374, 1975.
 120. Strauss HW: Cardiovascular nuclear medicine; a new look at an old problem. *Radiology* 121:257, 1975.
 121. Poe ND: Present status of positive scintigraphic imaging of myocardial infarction. *Scand J Clin Lab Invest* 36:401, 1976.
 122. Chervu LR: Radiopharmaceuticals in cardiovascular nuclear medicine. *Semin Nucl Med* 9:241, 1979.
 123. Mason DT: Digitalis pharmacology and therapeutics; recent advances. *Ann Intern Med* 80:520, 1974.
 124. Heinrich RS, Asburns WL, Depew MC, Halpren SE: Comparative, myocardial uptake of intravenously administered radionuclides. *J Nucl Med* 15:1092, 1974.
 125. Dodzuweit T, Lubbe WF, Opie LH: Cyclic adenosine monophosphate, ventricular fibrillation and antiarrhythmic drugs. *Lancet* 1:341, 1976.
 126. Entman ML, Goldstein MA, Schwartz A: The cardiac sarcoplasmic reticulum-glycogenolytic complex, and internal beta adrenergic receptor. *Life Sci* 19:1623, 1976.
 127. Schneider RM, Downing SE, Berger HJ, et al: Effect of methylprednisolone upon abnormal ^{99m}Tc pyrophosphate myocardial uptake following transthoracic DC countershock. *Circulation* 53-54(Suppl II):218, 1976.
 128. Chacko AK, Gordon DH, Bennett JM, et al: Myocardial imaging with Tc-99m pyrophosphate in patients on adriamycin treatment for neoplasia. *J Nucl Med* 18:680, 1977.
 129. Bristow MR, Thompson PD, Randolph PM, et al: Early anthracycline cardiotoxicity. *Am J Med* 65:823, 1978.
 130. Henderson IC, Frei III E: Adriamycin and the heart. *N Engl J Med* 300:310, 1979.
 131. Moncada S, Vane JR: Arachidonic acid metabolites and the interaction between platelets and blood-vessel walls. *N Engl J Med* 300:1142, 1979.
 132. Shine KI, et al: Noninvasive assessment of myocardial function. *Ann Intern Med* 92:78, 1980.
 133. Strauss HW, Pitt B: Thallium-201 as a myocardial imaging agent. *Semin Nucl Med* 7:49, 1977.
 134. Fukucki M, Tachibana K, Kuwata K, et al: Thallium-201 imaging in thyroid carcinoma—appearance of lymph node metastasis. *J Nucl Med* 19:195, 1978.
 135. Pierson RN, et al: Cardiovascular nuclear medicine; an overview. *Semin Nucl Med* 9:224, 1979.
 136. Gehring PJ, Hammond PB: The interrelationship between thallium and potassium in animals. *J Pharm Exp Therap* 155:187, 1967.
 137. Skulskii IA, Manninen V, Jarnefelt J: Factors affecting the relative magnitudes of the ouabain-sensitive and the ouabain-insensitive fluxes of thallium ion erythrocytes. *Biochim Biophys Acta* 506:233, 1978.
 138. Hamilton GW, Narahara KA, Yee H, et al: Myocardial imaging with thallium-201; effect of cardiac drugs on myocardial images and absolute tissue distribution. *J Nucl Med* 19:10, 1978.
 139. Zaret BL: Radionuclide imaging of myocardial ischemia and infarction. *Circulation* 53:1126, 1976.
 140. Moncada S, Vane JR: Unstable metabolites of arachidonic acid and their role in haemostasis and thrombosis. *Br Med Bull* 34:129, 1978.
 141. Hetzel KR, Westerman BR, Quinn III JL, et al: Myocardial uptake of thallium-201 augmented with bicarbonate; concise communication. *J Nucl Med* 18:24, 1977.
 142. Mayhan ML, Volpert EM, Fine EJ, et al: Thallium chloride 201 (TlCl-201) thyroidal uptake and its control by TSH. *J Nucl Med* 20:678, 1979.
 143. Brown CL: Drugs that affect radio-diagnostic testing of the thyroid. Unpublished communication.
 144. Thomas JD, Oddie TH, Myhill J: A diagnostic radioiodine test in patients receiving antithyroid drugs. *J Clin Endocrinol Metab* 20:1601, 1960.
 145. Linski JA, Paton BC, Persky M, et al: The effect of phenylbutazone and a related analogue (G25671) upon thyroid function. *J Clin Endocrinol Metab* 17:416, 1957.
 146. Grayson RR: Factors which influence the radioactive iodine uptake test. *Am J Med* 28:397, 1960.
 147. Sharpe AR: Inhibition of thyroidal I 131 uptake by parabromdylamine malcate. *J Clin Endocrinol Metab* 21:739, 1961.
 148. Ingbar SH, Freinkel N: ACTH, cortisone and the metabolism of I. *Metabolism* 5:652, 1956.
 149. Brown J, Solomon DH: Effect of tolbutamide and carbutamide in thyroid function. *Metabolism* 5:813, 1956.
 150. Wilbur JF, Utiger RD: The effect of glucocorticoids on thyrotropin secretion. *J Clin Invest* 48:2096, 1969.
 151. Buhler UK, Degroot LJ: Effect of stable iodine on thyroid iodine release. *J Clin Endocrinol Metab* 29:1546, 1969.
 152. Paley KR, Sobel ES, Yalow RS: Effect of oral and intravenous cobaltous chloride on thyroid function. *J Clin Endocrinol Metab* 18:850, 1958.
 153. Tubis M, Krishnamurthy GT, Endow JS, Bland WH: ^{99m}Tc -penicillamine, a new cholelscintigraphic agent. *J Nucl Med* 13:652, 1972.
 154. Whalen JJ, Merck, Sharpe & Dohme. Personal communication, 1980.

14

Iatrogenic Alterations in the Biodistribution of Radiotracers as a Result of Drug Therapy: Reported Instances

William B. Hladik III, James A. Ponto, Brian C. Lentle, and David L. Laven

This chapter is a compilation of reported instances in which the biodistribution of a radiopharmaceutical has been (or could be) modified by the administration of a therapeutic non-radioactive drug or contrast agent in such a way as to potentially interfere with the interpretation of the nuclear medicine study in question. This type of phenomenon is commonly referred to as a drug-radiopharmaceutical interaction (1-3). In this chapter, interactions are arranged according to the radiopharmaceutical involved; each interaction is characterized by use of the following descriptors:

1. *Interfering drug*: the interfering nonradioactive drug that alters the kinetics of the radiopharmaceutical and thus changes the resulting diagnostic data obtained from the study.
2. *Nuclear medicine study affected*: the nuclear medicine study in which the interaction is likely to occur.
3. *Effect on image*: the appearance of the image (or the effect on diagnostic data) which results from the interaction.
4. *Significance*: the potential clinical significance of the interaction. The significance of any given interaction depends on several factors:

- whether the clinician is aware that the interaction has been previously reported.
- whether the clinician is aware that the appropriate circumstances for the interac-

tion to occur are present in the patient being examined.

how easily the clinician is able to take into account the changes caused by the interaction as he or she interprets the image or data resulting from the diagnostic procedure.

Since these circumstances change from case to case, each interaction can be described only in terms of how it can be potentially interfering or annoying.

In most instances, drug-radiopharmaceutical interactions result in diagnostic confusion by inducing a pattern of radiopharmaceutical distribution which either (a) mimics that normally visualized with a naturally occurring disease process, (b) diminishes the ability to identify a naturally occurring disease process, or (c) demonstrates a combination of both of the preceding items (1). This classification will form the basis for discussion in the "significance" section.

5. *Mechanism*: the proposed mechanism by which the drug alters the kinetics of the radiopharmaceutical, i.e., the mechanism through which the interaction occurs.
6. *Management*: possible preventive or corrective management of the situation, not simply an awareness of the interaction.
7. *How documented*: the species in which the altered distribution and/or diagnostic data

have been reported (or the means by which the interaction has been documented).

8. **References:** literature references reporting the interaction and supporting (or conflicting) data.

REFERENCES

- Hladik WB III, Ponto JA, Stathis VJ: Drug-radiopharmaceutical interactions. In Thrall JH, Swanson DP (eds): *Diagnostic Interventions in Nuclear Medicine*. Chicago, Year Book Medical Publishers, 1985, pp 226-246.
- Lentle BC, Scott JR, Noujaim AA, et al: Iatrogenic alterations in radionuclide biodistributions. *Semin Nucl Med* 9:131-143, 1979.
- Hladik WB III, Nigg KK, Rhodes BA: Drug-induced changes in the biologic distribution of radiopharmaceuticals. *Semin Nucl Med* 12:184-218, 1982.

^{99m}Tc-LABELED COLLOIDS

Interfering drug(s): Short-term therapy with cancer chemotherapeutic agents, notably the nitrosoureas, e.g., carmustine, lomustine.

Nuclear medicine study affected: Liver and/or spleen scintigraphy.

Effect on image: Reported to cause transient changes in radiocolloid distribution sometimes; the specific changes observed have been (a) inhomogeneous or irregular distribution of radiocolloid in the liver, (b) hepatomegaly, and (c) a shift of radiocolloid from the liver to the spleen and/or bone marrow.

Significance: Since metastases to the liver from other primary cancers may, at times, be manifested as heterogeneous hepatic uptake of radiocolloid, this drug-induced pattern of distribution may be misinterpreted as malignancy. Distinct focal defects on liver and/or spleen scans (which is the more common pattern seen with metastases) have not been observed as a result of chemotherapy.

Mechanism: Not known; but presumably toxic effects of chemotherapeutic agents on hepatocytes and reticuloendothelial cells could cause the changes observed.

Management: Perform baseline liver and/or spleen studies prior to initiating therapy, if it is anticipated that additional studies will be performed at any time during the course of therapy. If necessary, repeat the study several weeks fol-

lowing the completion and/or discontinuation of therapy.

How documented: Study of 15 patients receiving single-agent or combination chemotherapy (1); also study of patients receiving methotrexate for treatment of psoriasis (2).

REFERENCES

- Kaplan WD, Drum DE, Lokich JJ: The effect of cancer chemotherapy agents on the liver-spleen scan. *J Nucl Med* 21:84-87, 1980.
- Geronemus RG, Auerbach R, Tobias H: Liver biopsies vs liver scans in methotrexate-treated patients with psoriasis. *Arch Dermatol* 118:649-651, 1982.

Interfering drug(s): Antacid therapy; virilizing androgen therapy.

Nuclear medicine study affected: Liver and/or spleen scintigraphy; bone marrow scintigraphy. **Effect on image:** Diffuse pulmonary accumulation of radiocolloid.

Significance: Multiple disease states as well as formulation problems with radiocolloid have been associated with diffuse lung uptake observed on liver and/or spleen studies. This pattern of distribution most frequently is associated with intrinsic liver disease. Major diagnostic interference does not result from the interaction, however.

Mechanism: With antacid therapy, intestinal absorption of abnormally high levels of aluminum (from aluminum-containing antacids) has occurred in patients with bowel obstruction or renal disease. Aluminum probably then reacts with the sulfur colloid to cause radioactive macroaggregates which are capable of blocking the pulmonary microcirculation (1).

The androgen therapy (or estrogen degradation products from the androgens), on the other hand, may stimulate the reticuloendothelial system, resulting in mobilization of large numbers of phagocytic cells from their storage sites, which are subsequently trapped in the pulmonary capillary bed (2). At this new location, the cells sequester intravascular radiocolloid.

Management: Not usually necessary; monitor plasma aluminum levels in selected cases.

How documented: Case report of liver and/or spleen study in individual receiving high-dose antacid therapy (3); study of 13 patients receiv-

ing virilizing androgen therapy for chronic anemia and 13 control patients also with chronic anemia, all monitored with bone marrow imaging (4).

REFERENCES

- Staum MM: Incompatibility of phosphate buffer in ^{99m}Tc-sulfur colloid containing aluminum ion. *J Nucl Med* 13:386-387, 1972.
- Mikhael MA, Evens RG: Migration and embolization of macrophages to the lung—a possible mechanism for colloid uptake in the lung during liver scanning. *J Nucl Med* 16:22-27, 1975.
- Bobinet DD, Sevrin R, Zurbriggen MT, et al: Lung uptake of Tc-99m sulfur colloid in patient exhibiting presence of Al³⁺ in plasma. *J Nucl Med* 15:1220-1222, 1974.
- Sayle BA, Helmer RE III, Balachandran S, et al: Lung uptake of Tc-99m sulfur colloid secondary to androgen therapy in patients with anemia. *Nucl Med Commun* 2:1289-1293, 1981.

Interfering drug(s): General anesthetic agents, e.g., halothane.

Nuclear medicine study affected: Liver and/or spleen scintigraphy.

Effect on image: Shift of radiocolloid from liver to spleen.

Significance: Colloid shift is commonly observed in patients with intrinsic liver disease, e.g., cirrhosis.

Mechanism: General anesthetic agents can cause a decrease in hepatic blood flow and, therefore, may reduce hepatic extraction of radiocolloid. In addition, these drugs are hepatotoxic in some patients which may contribute to decreased hepatic uptake of radiocolloid.

Management: Monitor patient closely for signs of hepatotoxicity.

How documented: Colloid shift documented in 14 of 20 patients with a history of surgery within the previous month (1).

REFERENCE

- Lentle BC, Scott JR, Noujaim AA, et al: Iatrogenic alterations in radionuclide biodistributions. *Semin Nucl Med* 9:131-143, 1979.

Interfering drug(s): Thorium dioxide.

Nuclear medicine study affected: Liver and/or spleen scintigraphy.

Effect on image: Absence of spleen localization.

Significance: Since thorium dioxide has not, for many decades, been used as a radiopaque contrast media, this effect is very rarely seen. When it does occur, however, it may interfere with the differential diagnosis of functional asplenia.

Mechanism: α -Particles emitted in the decay of thorium deliver a high radiation dose to the spleen, resulting in splenic atrophy.

Management: None.

How documented: Case report (1).

REFERENCE

- Burroughs AK, Bass NM, Wood J, et al: Absence of splenic uptake of radiocolloid due to Thorotrast in a patient with Thorotrast-induced cholangiocarcinoma. *Br J Radiol* 55:598-600, 1982.

^{99m}Tc-LABELED IMINODIACETIC ACID DERIVATIVES

Interfering drug(s): Narcotic (opioid) analgesics (e.g., morphine, meperidine); pentobarbital.

Nuclear medicine study affected: Cholescintigraphy.

Effect on image: Delayed biliary-to-bowel transit time (i.e., delayed visualization of radio-tracer in intestine) with radioactivity remaining in the gallbladder or in the common bile duct but not released into the duodenum.

Significance: This pattern of distribution may mimic that observed with mechanical obstruction of the common bile duct or with other nonspecific gallbladder disease. The significance of this interaction is increased, since many patients with right upper quadrant pain are treated with narcotic analgesics in the emergency room prior to referral to nuclear medicine for examination.

Mechanism: Narcotic analgesics increase intrabiliary pressure and cause spasm of the sphincter of Oddi, thus preventing the movement of radio-tracer into the small bowel. (Neostigmine may enhance the effect of narcotic analgesics.)

Management: An alternative type of analgesic may be given but usually is less effective for pain that is often associated with gallbladder disease. When it is clinically feasible, the study may be delayed for several hours until the effect of the drug dissipates, although this time varies from patient to patient.

How documented: Study in dogs (1); several case reports (2–5); two prospective clinical studies (6,7).

REFERENCES

1. Durakovic A, Dubois A: Effect of ketamine, pentobarbital, and morphine on Tc-99m DISIDA hepatobiliary kinetics. *J Nucl Med* 26:P79, 1985.
2. Taylor A Jr, Kipper MS, Witztum K, et al: Abnormal Tc-99m PIPIDA scans mistaken for common duct obstruction. *Radiology* 144:373–375, 1982.
3. Sefczek DM, Sharma P, Isaacs GH, et al: Effect of narcotic premedication on scintigraphic evaluation of gallbladder perforation. *J Nucl Med* 26:51–53, 1985.
4. Pope RJ, Bratke J: Two Tc-HIDA cases with delayed emptying into duodenum. *Monthly Scan* July 1981.
5. Lim RE, Dubovsky EV, Tim LO, et al: Morphine-Prostigmin test—effect on Tc-99m DISIDA cholescintigraphy. *Clin Nucl Med* 7:213–214, 1982.
6. Lim RE, Yester MV, Smith B, et al: Effect of morphine and neostigmine on cholescintigraphy. *Clin Nucl Med* 6:P141, 1981.
7. Joehi RJ, Koch KL, Nahrwald DL: Opioid drugs cause bile duct obstruction during hepatobiliary scans. *Am J Surg* 147:134–138, 1984.

Interfering drug(s): Nicotinic acid (chronic, high-dose therapy).

Nuclear medicine study affected: Cholescintigraphy.

Effect on image: Poor extraction and elimination of radiotracer.

Significance: Pattern of distribution is typical of that observed with intrinsic hepatocellular disease. Therefore, unless one is familiar with toxic effects of drugs, the cause for the change in radiotracer kinetics may be easily missed. (Apparently short-term, low-dose therapy does not have the same effect as chronic high-dose therapy (1).)

Mechanism: Toxic effect of drug on hepatocytes.

Management: Repeat study several weeks following discontinuation of therapy (or following dosage reduction).

How documented: One case report (2).

REFERENCES

1. Shafer RB, Knodell RG, Stanley IN, et al: Acute effects of nicotinic acid on hepatic transport of Tc-99m PIPIDA. *Eur J Nucl Med* 8:12–14, 1983.
2. Richards AG, Brighthouse R: Nicotinic acid—a cause of failed HIDA scanning. *J Nucl Med* 22:746–747, 1981.

Interfering drug(s): Total parenteral nutrition (TPN) therapy.

Nuclear medicine study affected: Cholescintigraphy.

Effect on image: Absent or delayed visualization of the gallbladder (in patients with no gallbladder disease).

Significance: This pattern of distribution mimics that typically observed with cholecystitis, resulting in false positive images and, sometimes, unnecessary surgery. (TPN-induced gallbladder stasis may, however, be a risk factor for cholelithiasis (1).)

Mechanism: During TPN therapy, the gallbladder is relatively inactive, which results in bile stasis and the formation of a thick viscous jelly-like bile within the gallbladder that impedes flow of radiotracer into the gallbladder.

Management: Theoretically, sincalide or cholecystokinin may be used to clear a pathway for radiotracer entry into the gallbladder; however, limited clinical experience with sincalide in TPN patients does not support the efficacy of this hypothesis. Ultrasonography should be used as an adjunct to confirm the presence or absence of gallbladder disease.

How documented: Prospective study of cholescintigraphy in patients on TPN therapy (2); retrospective chart review of 200 consecutive patients who received ^{99m}Tc-*p*-isopropylimino-diacetic acid (PIPIDA) for hepatobiliary imaging (3).

REFERENCES

1. Messing B, Bories C, Kunstlinger F, et al: Does total parenteral nutrition induce gallbladder sludge formation and lithiasis? *Gastroenterology* 84:1012–1019, 1984.
2. Potter T, McClain CJ, Shafer RB: Effect of fasting and parenteral alimentation on PIPIDA scintigraphy. *Dig Dis Sci* 28:687–691, 1983.
3. Shuman WP, Gibbs P, Rudd TG, et al: PIPIDA scintigraphy for cholecystitis: false positives in alcoholism and total parenteral nutrition. *AJR* 138:1–5, 1982.

Interfering drug(s): Hepatic artery infusion chemotherapy.

Nuclear medicine study affected: Hepatobiliary scintigraphy.

Effect on image: Nonvisualization of the gallbladder.

Significance: Scintigraphic evidence of cholecystitis is very common, if not uniformly present, during hepatic artery infusion chemotherapy. Cholecystectomy may not be indicated in these patients, however, unless acute clinical signs and symptoms accompany the scintigraphic findings.

Mechanism: Hepatic artery infusion chemotherapy frequently induces a chemical cholecystitis, which is not surprising since, in the vast majority of patients receiving this therapy, the gallbladder is included in the region perfused.

Management: Perform confirmatory diagnostic tests to determine the seriousness of the cholecystitis. If the patient is not symptomatic, surgery is probably not necessary.

How documented: Clinical study with case reports (1).

REFERENCE

1. Housholder DF, Hynes HE, Dakhil SR, et al: Hepatobiliary scintigraphy in patients receiving hepatic artery infusion chemotherapy. *J Nucl Med* 26:474–477, 1985.

^{99m}Tc-LABELED PHOSPHATES AND PHOSPHONATES

Interfering drug(s): Iron-containing compounds; Phospho-Soda; acute administration of diphosphonate.

Nuclear medicine study affected: Skeletal scintigraphy.

Effect on image: Decreased osseous uptake of bone imaging agents and, in some cases, an increase in intravascular activity.

Significance: It is not known to what extent skeletal lesions, compared with normal bone, may be affected by this interaction. Therefore, the significance is uncertain. Some slight confusion may result, however, since osteoporosis and congestive heart failure, among other disorders, may also cause a generalized decrease in the uptake of skeletal imaging agents by bone. In addition, in those cases in which increased blood background is present, the ratio of bone-to-background radioactivity is diminished, thus potentially decreasing lesion detectability. (Apparently the chronic administration of therapeutic diphosphonate does not affect uptake of radiotracer by bone (1, 2).)

Mechanism: With regard to iron-containing drugs, it has been postulated that an in vivo transchelation may occur, resulting in a ^{99m}Tc compound that has less affinity for bone. Alternatively, some iron compounds (e.g., iron dextran) may form an intravascular complex with the ^{99m}Tc-labeled skeletal imaging agents which does not readily distribute to bone but instead remains in the blood pool.

With Phospho-Soda, the phosphate ions in the drug may saturate bone-binding sites to a certain extent, resulting in competitive inhibition of skeletal binding with the ^{99m}Tc-labeled phosphonates.

With diphosphonate (Didronel), the mechanism is unclear, but the alterations in bone uptake probably represent changes induced by the drug at the site of hydroxyapatite crystal or calcium phosphate deposition.

Management: If clinically appropriate, discontinue iron therapy or Phospho-Soda therapy prior to skeletal scintigraphy, keeping in mind that the biologic half-life of iron dextran, in particular, is relatively long. Do not administer nonradioactive disphosphonate within a few hours of the administration of ^{99m}Tc-phosphonate.

How documented: Studies in rats (3–5); case reports (6–8).

REFERENCES

1. Lee, JY: Bone scintigraphy in evaluation of Didronel therapy for Paget's disease. *Clin Nucl Med* 6:356–358, 1981.
2. Espinasse D, Mathieu L, Alexandre C, et al: The kinetics of Tc-99m labeled EHDP in Paget's disease before and after dichloromethylene-diphosphonate treatment. *Metab Bone Dis Rel Res* 2:321–324, 1981.
3. McRae J, Hambright P, Valk P, et al: Chemistry of Tc-99m tracers. II. In vitro conversion of tagged HEDP and pyrophosphate (bone-seekers) into gluconate (renal agent). Effects of Ca and Fe(II) on in vivo distribution. *J Nucl Med* 17:208–211, 1976.
4. Choy D, Maddalena DJ, Murray IPC: The effect of iron-dextran on the biodistribution of technetium pyrophosphate. *Int J Nucl Med Biol* 9:277–282, 1982.
5. Watt I, Hill P: Effect of acute administration of ethane hydroxydiphosphonate (EHDP) on skeletal scintigraphy with technetium-99m methylene diphosphonic acid (Tc-MDP) in the rat. *Br J Radiol* 54:592–596, 1981.
6. Parker JA, Jones AG, Davis MA, et al: Reduced uptake of bone-seeking radiopharmaceuticals related to iron excess. *Clin Nucl Med* 1:267–268, 1976.

- Choy D, Murray IPC, Hoschl R: The effect of iron on the biodistribution of bone scanning agents in humans. *Radiology* 140:197-202, 1981.
- Saha GB, Herzberg DL, Boyd CM: Unusual in vivo distribution of Tc-99m diphosphonate. *Clin Nucl Med* 2:303-305, 1977.

Interfering drug(s): Iron-containing compounds; amphotericin B; gentamicin; cyclophosphamide; vincristine; doxorubicin.

Nuclear medicine study affected: Skeletal scintigraphy.

Effect on image: Increased renal retention of radiotracer.

Significance: The presence of radiotracer in the kidneys on a bone scan may be confused with disease processes such as renal vascular disease or urinary tract obstruction.

Mechanism: With iron-containing compounds, an in vivo transchelation may form a ^{99m}Tc-labeled kidney-seeking agent.

With antibiotics and cancer chemotherapeutic agents, the renal localization may be due to a nephrotoxic effect of the drugs, i.e., tubular or vascular damage.

Management: None; skeletal imaging itself may be a means to monitor nephrotoxic effects of drugs (1).

How documented: Studies in rats (1,2); case reports (3-5); retrospective study of bone imaging in children receiving cancer chemotherapy (6).

REFERENCES

- McAfee JG, Singh A, Roskopf M, et al: Experimental drug-induced changes in renal function and biodistribution of Tc-99m MDP. *Invest Radiol* 18:470-478, 1983.
- McRae J, Hambright P, Valk P, et al: Chemistry of Tc-99m tracers. II. In vitro conversion of tagged HEDP and pyrophosphate (bone-seekers) into gluconate (renal agent). Effects of Ca and Fe(II) on in vivo distribution. *J Nucl Med* 17:208-211, 1976.
- Glass EC, DeNardo GL, Hines HH: Immediate renal imaging and renography with ^{99m}Tc methylene diphosphonate to assess renal blood flow, excretory function, and anatomy. *Radiology* 135:187-190, 1980.
- Trackler RT, Chinn RYW: Amphotericin B therapy—a cause of increased renal uptake of Tc-99m MDP. *Clin Nucl Med* 7:293, 1982.
- Siddiqui AR: Increased uptake of technetium-99m labeled bone imaging agents in the kidneys. *Semin Nucl Med* 12:101-102, 1982.
- Lutrin CL, McDougall IR, Goris ML: Intense concentration of technetium-99m pyrophosphate in the kidneys of

children treated with chemotherapeutic drugs for malignant disease. *Radiology* 128:165-167, 1978.

Interfering drug(s): "Cytotoxic" cancer chemotherapy.

Nuclear medicine study affected: Skeletal scintigraphy.

Effect on image: Diffuse activity around calvarium which has been termed the "sickle sign."

Significance: This pattern of distribution can be distinguished from meningeal carcinosis and skull metastases only when a vertex view is taken. With the vertex view, the disease processes are seen as localized uptake or heterogeneous distribution, whereas the drug-induced changes are manifest as homogeneous distribution of the radiotracer.

Mechanism: Unknown.

Management: A vertex view should be included in skeletal imaging protocol in patients in whom this confusion may arise.

How documented: Prospective study of skeletal imaging in patients undergoing intensive cytotoxic therapy for breast cancer, compared with patients taking hormonal therapy for prostatic cancer (1).

REFERENCE

- Creutzig H, Wolfgang D: The "sickle-sign" in bone scintigraphy. *Eur J Nucl Med* 6:99-101, 1981.

Interfering drug(s): Aluminum-containing antacids.

Nuclear medicine study affected: Skeletal scintigraphy.

Effect on image: Appearance of liver on bone scan.

Significance: Interaction is of minimal clinical significance. However, metastatic liver disease, amyloidosis, hepatic necrosis, hypercalcemia, and a few other diseases sometimes are associated with this same pattern of distribution; thus, there may be some interference with the differential diagnosis.

Mechanism: It has been proposed that a sub-micron (submicroscopic) colloid is formed as a result of a complexing phenomenon between aluminum and the radiopharmaceutical, although this has never been verified. Case studies (and animal experiments) have shown that

liver uptake of radioactivity occurs when aluminum is mixed with bone-seeking radiotracers in vitro. The phenomenon also occurs when bone-imaging agents are injected into rats with elevated plasma levels of aluminum.

Management: None; if liver uptake occurs on a bone scan, it may be helpful to measure the concentration of aluminum in the patient's plasma.

How documented: Studies in rats (1-4) and case studies resulting from preparation of radiopharmaceuticals using generator eluate with elevated aluminum levels (4).

REFERENCES

- Jaresko GS, Zimmer AM, Pavel DG, et al: Effect of circulating aluminum on the biodistribution of Tc-99m-Sn-diphosphonate in rats. *J Nucl Med Technol* 8:160-161, 1980.
- Zimmer AM, Pavel DG: Experimental investigations of the possible cause of liver appearance during bone scanning. *Radiology* 126:813-816, 1978.
- Chaudhuri TK: The effect of aluminum and pH on altered body distribution of Tc-99m EHDP. *Int J Nucl Med Biol* 3:37, 1976.
- Chaudhuri TK: Liver uptake of Tc-99m-diphosphonate. *Radiology* 119:485-486, 1976.

Interfering drug(s): Sodium diatrizoate.

Nuclear medicine study affected: Skeletal scintigraphy.

Effect on image: Marked renal and hepatic localization of radiotracer.

Significance: As discussed previously, several diseases induce this same pattern of distribution (see other monographs under ^{99m}Tc-labeled phosphates and phosphonates).

Mechanism: The osmotic effect of the contrast material may cause the increased renal activity by inhibition of the normal tubular reabsorption of the ^{99m}Tc-phosphate. The hepatic and the renal uptake of the tracer could be due to an elevation of the local in vivo pH as a result of the administration of contrast media (1,2).

Management: On any given day, perform skeletal scintigraphy study prior to procedures requiring the injection of contrast media.

How documented: Case report (3).

REFERENCES

- Chaudhuri TK: The effect of aluminum and pH on altered body distribution of ^{99m}Tc-EHDP. *Int J Nucl Med Biol* 3:37, 1976.

- Hoogland DR, Forstrom L, Madhal AF, et al: Effects of pH on tissue distribution of ^{99m}Tc-pyrophosphate (PYP) in bone imaging (abstract). *Med Imaging* 2:39, 1977.

- Crawford JA, Gumerman LW: Alteration of body distribution of ^{99m}Tc-pyrophosphate by radiographic contrast material. *Clin Nucl Med* 3:305-307, 1978.

Interfering drug(s): Regional chemoperfusion; injections of calcium gluconate, iron dextran, heparin calcium, meperidine.

Nuclear medicine study affected: Skeletal scintigraphy.

Effect on image: Extrasosseous accumulation of radiotracer.

Significance: At times, the drug-induced extrasosseous localization of ^{99m}Tc-labeled phosphonates may be indistinguishable from disorders of the bone, e.g., the extravasation of calcium gluconate has been reported to simulate osteomyelitis. Regional chemoperfusion causes an increase in activity in local skeletal structures and the surrounding soft tissue which may be confused with a malignant process. Sites of extrasosseous radiotracer uptake may also be confused with other pathologies not related to drug therapy.

Mechanism: With regional chemoperfusion of cancer drugs, the resulting hyperemia may contribute to increased uptake of tracer locally.

With iron dextran, the mechanism may be a local complexing of ^{99m}Tc-diphosphonate with iron dextran or, alternatively, a combination of reduced technetium with either ferric hydroxide or dextran after release of these components from the iron dextran complex.

With extravasation of intravenous calcium gluconate or injection of subcutaneous calcium heparin, if the concentration of calcium in the tissue exceeds the capabilities of local solubility, precipitation of calcium, which could elicit an inflammatory reaction, may occur.

Management: None.

How documented: Study in rabbits (1); case reports (1-9).

REFERENCES

- Planchon CA, Donadieu A, Perez R, et al: Calcium heparinate induced extrasosseous uptake in bone scanning. *Eur J Nucl Med* 8:113-117, 1983.
- Sorkin SJ, Horii SC, Passalacqua A, et al: Augmented activity on bone scan following local chemoperfusion. *Clin Nucl Med* 2:451, 1977.

- Mazzola AL, Barker MH, Belliveau RE: Accumulation of Tc-99m diphosphonate at sites of intramuscular iron therapy: case report. *J Nucl Med Technol* 4:133-135, 1976.
- VanAntwerp JD, Hall JN, O'Mara RE, et al: Bone scan abnormality produced by interaction of Tc-99m diphosphonate with iron dextran (Imferon). *J Nucl Med* 16:577, 1975.
- Byun HH, Rodman SG, Chung KE: Soft-tissue concentration of Tc-99m phosphates associated with injection of iron dextran complex. *J Nucl Med* 17:374-375, 1976.
- Balsam D, Goldfarb CR, Stringer B, et al: Bone scintigraphy for neonatal osteomyelitis: simulation by extravasation of intravenous calcium. *Radiology* 135:185-186, 1980.
- Go RT, Cook SA, Abu-Yousef M, et al: Etiology of soft tissue localization in radionuclide bone imaging. Scientific exhibit presented at the 28th Annual Meeting of the Society of Nuclear Medicine. Las Vegas, June 1981.
- Brill DR: Radionuclide imaging of nonneoplastic soft tissue disorders. *Semin Nucl Med* 11:277-288, 1981.
- Duong RB, Volarich DT, Fernandez-Ulloa M, et al: Tc-99m MDP bone scan artefact—abdominal soft tissue uptake secondary to subcutaneous heparin injection. *Clin Nucl Med* 9:47, 1984.

Interfering drug(s): Diethylstilbestrol (estrogens).

Nuclear medicine study affected: Skeletal scintigraphy.

Effect on image: Accumulation of radiotracer in breast tissue.

Significance: Interaction is of minimal clinical significance. However, breast uptake occurs in normal breasts, in benign breast lesions, in primary breast carcinomas, and in metastatic adenocarcinomas; thus there may be some interference with the differential diagnosis.

Mechanism: The mechanism of uptake is unknown, although it has been suggested that this uptake may result from the binding of phosphates or diphosphonates to receptor sites on enzymes such as phosphatases (1).

Management: None.

How documented: Case report (2).

REFERENCES

- Schmitt GH, Holmes RA, Isitman AT, et al: A proposed mechanism for ^{99m}Tc-labeled polyphosphate and diphosphonate uptake by human breast tissue. *Radiology* 112:733-735, 1974.
- RamSingh PS, Pujara S, Logic JR: Tc-99m pyrophosphate uptake in drug-induced gynecomastia. *Clin Nucl Med* 2:206, 1977.

Interfering drug(s): Corticosteroids.

Nuclear medicine study affected: Skeletal scintigraphy.

Effect on images: Decreased or absent uptake of radiotracer in bone, especially at major joints.

Significance: Since the effect is decreased bone localization, it will not be confused with metastatic or other common bone diseases. However, since this pattern of distribution is observed with a few other disorders, there may be some interference with differential diagnosis.

Mechanism: Steroids may cause ischemic necrosis of bone.

Management: None.

How documented: Clinical study (1).

REFERENCE

- Conklin JJ, Alderson PO, Zizic TM, et al: Comparison of bone scan and radiograph sensitivity in the detection of steroid-induced ischemic necrosis of bones. *Radiology* 147:221-226, 1983.

Interfering drug(s): ε-Amino caproic acid.

Nuclear medicine study affected: Skeletal scintigraphy.

Effect on image: Markedly increased uptake of radiotracer in muscle.

Significance: This interaction is significant only in that muscle uptake in patients with myopathy may reduce skeletal visualization.

Mechanism: Some patients on this drug develop a myopathy, the cause of which is not clear. This condition is apparently helped by bed rest.

Management: Bed rest preceding the examination is recommended in affected patients if the bone scintigraphy is to be performed for conventional indications. The technique appears of potential use, however, in the monitoring of myopathy.

How documented: Evidence of the myopathy is well documented (1) with a case report of the scintigraphy findings in humans (2).

REFERENCES

- Brown JA, Wollmann RL, Mullan S: Myopathy induced by epsilon aminocaproic acid. *J Neurosurg* 57:130-134, 1982.
- Van Renterghem D, De Reuck J, Schelstracte K, et al: Epsilon aminocaproic acid myopathy: additional features. *Clin Neurol Neurosurg* 86:153-157, 1984.

Interfering drug(s): Diphosphonate.

Nuclear medicine study affected: Avid infarct scintigraphy (^{99m}Tc-pyrophosphate).

Effect on image: Decreased uptake of radiotracer in infarcted myocardium and an increase in radioactivity in normal myocardium.

Significance: If data are applicable to humans, a decrease in lesion detectability may result from the interaction. Furthermore, certain pathologic conditions which are associated with increased serum phosphate levels, altered pyrophosphate metabolism, and/or decreased renal excretion of pyrophosphate also may cause significant impairment of the diagnostic accuracy of ^{99m}Tc-pyrophosphate myocardial scintigraphy.

Mechanism: Possibly due to saturation of ^{99m}Tc-pyrophosphate-binding sites by diphosphonate and dilution of ^{99m}Tc-pyrophosphate in the circulating diphosphonate pool at the time of ^{99m}Tc-pyrophosphate injection.

Management: Avoid concomitant use of non-radioactive diphosphonate in patients undergoing ^{99m}Tc-pyrophosphate scintigraphy for localization of myocardial infarct.

How documented: Study in dogs (1).

REFERENCE

- Buja IM, Tofe AJ, Parkey RW, et al: Effect of EHDP on calcium accumulation and technetium-99m pyrophosphate uptake in experimental myocardial infarction. *Circulation* 64:1012-1017, 1981.

Interfering drug(s): Doxorubicin.

Nuclear medicine study affected: Avid infarct scintigraphy (^{99m}Tc-pyrophosphate).

Effect on image: Diffuse uptake of the radiotracer in the myocardium.

Significance: Interaction is of minimal clinical significance, since the uptake in this case is diffuse, unlike the more localized uptake noted in infarctions. However, since diffuse uptake may be observed in many other cardiac conditions, including angina, ventricular aneurysm, congestive cardiomyopathy, chest irradiation, calcified intracardiac valves, pericarditis, and cardioversion, there may be some interference with the differential diagnosis.

Mechanism: Doxorubicin-induced cardiac toxicity initially presents as diffuse microscopic damage to the myocardium. Cellular damage

such as this allows accumulation of ^{99m}Tc-pyrophosphate.

Management: None.

How documented: Prospective clinical study (1).

REFERENCE

- Chacko AK, Gordon DH, Bennett JM, et al: Myocardial imaging with Tc-99m pyrophosphate in patients on adriamycin treatment for neoplasia. *J Nucl Med* 18:680-683, 1977.

^{99m}Tc-GLUCEPTATE

Interfering drug(s): Pencillin; acetaminophen; trimethoprim-sulfamethoxazole.

Nuclear medicine study affected: Renal scintigraphy.

Effect on image: Enhanced excretion of radiotracer through the hepatobiliary system.

Significance: Radioactivity in the gallbladder could be confused with abnormal kidney localization. (Since hepatobiliary excretion of ^{99m}Tc-glucaptate also occurs in healthy patients in the fasting state (1), and since this phenomenon was not taken into consideration when the interaction was studied and/or reported, the significance of the interaction is not known.)

Mechanism: Theoretically, in vivo transchelation occurs between glucaptate and metabolites of the drugs, thus forming a ^{99m}Tc species which is eliminated to a large extent via the hepatobiliary system.

Management: None.

How documented: Chart review and follow-up study in rabbits (2).

REFERENCES

- Tyler JA, Powers TA: Gallbladder visualization with technetium-99m glucoheptonate: concise communication. *J Nucl Med* 23:870-871, 1982.
- Hinkle GH, Basmadjian GP, Peck C, et al: Effects of concurrent drug therapy on technetium Tc-99m glucoheptonate biodistribution. *Am J Hosp Pharm* 39:1930-1933, 1982.

^{99m}Tc-DIMERCAPTOSUCCINIC ACID (DMSA)

Interfering drug(s): Ammonium chloride; sodium bicarbonate; mannitol.

Nuclear medicine study affected: Renal scintigraphy.

Effect on image: Administration of ammonium chloride may substantially decrease renal distribution and increase hepatic distribution of ^{99m}Tc -DMSA; administration of sodium bicarbonate and mannitol may also decrease the distribution of the radiopharmaceutical to the kidney.

Significance: The possibility that drugs may induce acid-base imbalance and/or dehydration and thereby affect the distribution of ^{99m}Tc -DMSA should be considered in patients receiving this radiopharmaceutical. Comparison of sequential renal studies may be impaired if drug therapy is initiated at some point after the initial study is performed. In addition, false overestimates of right renal kidney activity may occur when there is an increased hepatic contribution to the count rate.

Mechanism: Ammonium chloride may exert its effect on distribution by inducing acidosis and acidification of the urine; sodium bicarbonate induces alkalization of the urine, whereas mannitol can cause dehydration, both of which may affect the distribution of the radiotracer. Mannitol also may decrease the extraction fraction of ^{99m}Tc -DMSA through its effect on transit time.

Management: Discontinue drug therapy and assure that the patient is adequately hydrated prior to performing renal scintigraphy.

How documented: Study in rats (1).

REFERENCE

1. Yee CA, Lee HB, Blaifox MD: Tc-99m DMSA renal uptake: influence of biochemical and physiologic factors. *J Nucl Med* 22:1054-1058, 1981.

Interfering drug(s): Captopril.

Nuclear medicine study affected: Renal scintigraphy.

Effect on image: In patients with hypertension and unilateral renal artery stenosis, there may be a decreased renal uptake of ^{99m}Tc -DMSA by the affected kidney (reversible following discontinuance of captopril).

Significance: This pattern of distribution may indicate a deterioration of glomerular filtration as a result of drug therapy, rather than a worsening of the underlying disease process; thus, confusion may arise as to the cause of the diminished radiotracer uptake.

Mechanism: When renal perfusion pressure is reduced by renal artery stenosis, effective filtration pressure and glomerular filtration normally are conserved by constriction of efferent arterioles. This efferent arteriolar constriction is mediated by angiotensin II. Since captopril inhibits the formation of angiotensin II, the drug may induce a reversible, functional renal insufficiency. Therefore, diminished ^{99m}Tc -DMSA uptake in a stenotic kidney during captopril therapy may be due to a loss of effective transmembrane filtration pressure on the involved side.

Management: It may be necessary to replace captopril with another antihypertensive agent, e.g., minoxidil, prior to performance of renal scintigraphy. If a low or absent renal uptake of the radiotracer is noted in a patient with proven or suspected renal artery stenosis on captopril therapy, further investigation (e.g., with ^{123}I or ^{131}I iodohippurate) may be warranted to determine whether the apparent functional loss is reversible and drug-related.

How documented: Case report (1).

REFERENCE

1. Kremer Hovinga TK, Beukhof JR, van Luyk WH, et al: Reversible diminished renal ^{99m}Tc -DMSA uptake during converting-enzyme inhibition in a patient with renal artery stenosis. *Eur J Nucl Med* 9:144-146, 1984.

^{99m}Tc -LABELED MACROAGGREGATED ALBUMIN AND ALBUMIN MICROSPHERES

Interfering drug(s): Heparin.

Nuclear medicine study affected: Pulmonary perfusion scintigraphy.

Effect on image: Appearance of perfusion image is that typically observed with pulmonary emboli.

Significance: Since thromboembolic disease associated with heparin-induced thrombocytopenia is a relatively rare occurrence, the paradoxical deterioration on perfusion scans in patients receiving heparin therapy may come as a surprise to the clinician.

Mechanism: The presence of a heparin-dependent IgG antibody in patients with delayed-onset, heparin-induced thrombocytopenia has been reported to predispose these patients to

thrombosis which may result in pulmonary emboli.

Management: Heparin should be discontinued immediately in patients with delayed-onset, severe thrombocytopenia with heparin-dependent antibody and should be replaced with oral anticoagulation.

How documented: Although this phenomenon has not been reported in the nuclear medicine literature, clinicians should be aware of its possible occurrence (1-3).

REFERENCES

1. Chong BH, Pitney WR, Castaldi PA: Heparin-induced thrombocytopenia: association of thrombotic complications with heparin-dependent IgG antibody that induces thromboxane synthesis and platelet aggregation. *Lancet* 1:1246-1248, 1982.
2. Kapsch DN, Silver D: Heparin-induced thrombocytopenia with thrombosis and haemorrhage. *Arch Surg* 116:1423-1427, 1981.
3. Towne JB, Bernhard VM, Hussey C, et al: White clot syndrome: peripheral vascular complications of heparin therapy. *Arch Surg* 114:372-377, 1979.

^{99m}Tc PERTECHNETATE

Interfering drug(s): Aluminum-containing antacids; sulfonamides; stannous ion-containing drugs and radiopharmaceuticals.

Nuclear medicine study affected: Brain scintigraphy; thyroid scintigraphy; Meckel's diverticulum scintigraphy.

Effect on image: The noted drugs may result in a failure of ^{99m}Tc pertechnetate to leave the vascular space; i.e., increased blood pool activity is seen on the image. For example, increased activity has been observed during brain scintigraphy in the superior sagittal sinus, the transverse sinuses, and the region of the choroid plexus (when scintigraphy has been performed following bone scintigraphy).

Significance: Decreased or absent uptake of ^{99m}Tc pertechnetate into normal tissue (e.g., thyroid) or diseased tissue (e.g., brain disorders or Meckel's diverticulum) may result in missed diagnoses in these organs. There is, however, conflicting data concerning the effect of prior stannous ion administration on the distribution of ^{99m}Tc pertechnetate into the thyroid and stomach, i.e., whether it causes an increased or decreased uptake into these organs.

Mechanism: It is not known how excess alumi-

num ion concentration in the serum adversely affects the biodistribution of ^{99m}Tc pertechnetate. Renal and gastrointestinal disorders, as well as chronic ingestion of aluminum-containing antacids, can result in elevated levels of aluminum in the blood.

Both stannous ion and sulfonamides cause radiolabeling of red blood cells; stannous ion does this by reducing the pertechnetate ion intracellularly, whereas the mechanism for sulfonamide-induced erythrocyte labeling is unclear.

Management: When it is clinically feasible, discontinue therapy several days prior to imaging or, alternatively, use agents other than ^{99m}Tc pertechnetate for brain or thyroid imaging.

How documented: Study in rabbits (1); studies in rats (2,3); prospective clinical studies (4,5); and several case reports (1,6,7).

REFERENCES

1. Chervu LR, Castronuovo JJ, Huq SS, et al: Alterations in red cell tagging with sulfonamides. *J Nucl Med* 22:P70, 1981.
2. McRae J, Sugar RM, Shipley B, et al: Alterations in tissue distribution of Tc-99m pertechnetate in rats given stannous tin. *J Nucl Med* 15:151-155, 1974.
3. Khentigan A, Garrett M, Lum D, et al: Effects of prior administration of Sn(II) complexes on in vivo distribution of Tc-99m pertechnetate. *J Nucl Med* 17:380-384, 1976.
4. Ancrì D, Lonchamps M, Basset J: The effect of tin on the tissue distribution of Tc-99m sodium pertechnetate. *Radiology* 124:445-450, 1977.
5. Chandler WM, Shuck LD: Abnormal technetium-99m pertechnetate imaging following stannous pyrophosphate bone imaging. *J Nucl Med* 16:518-519, 1975.
6. Wang TST, Fawwaz RA, Esser PD, et al: Altered body distribution of Tc-99m pertechnetate in iatrogenic hyperalbuminemia. *J Nucl Med* 19:381-383, 1978.
7. Montelibano EB, Ford DR, Sayle BA: Altered Tc-99m pertechnetate distribution in a thyroid scan after Tc-99m Sn pyrophosphate administration. *Clin Nucl Med* 4:277-278, 1979.

^{99m}Tc -LABELED RED BLOOD CELLS

Interfering drug(s): β -Adrenergic blockers (e.g., propranolol); calcium channel blockers (e.g., verapamil); nitrates (e.g., nitroglycerin).

Nuclear medicine study affected: Radionuclide ventriculography.

Effect on image: Therapy with β -adrenergic blockers, calcium channel blockers, or nitrates

may result in normal exercise radionuclide ventriculograms even in the presence of significant coronary artery disease (CAD).

Significance: The presence or severity of CAD may be missed and/or underestimated.

Mechanism: Two possible mechanisms may be responsible for the effects of β -adrenergic blocking agents. First, the effects may result from drug-induced changes in the exercise performance of patients. The administration of a β -blocker blunts the normal rise in heart rate and systolic blood pressure which occurs with exercise, resulting in a reduction in myocardial oxygen consumption. In addition, β -blockers may increase myocardial oxygen extraction and augment stroke volume despite a tendency for the cardiac output to decrease. The overall effect of these changes on exercise ability depends on the underlying function of the left ventricle. Patients with CAD and impaired left ventricular function typically show a greater and more consistent increase in exercise performance than do individuals without CAD. The net effect of β -blockade therapy on exercise radionuclide ventriculography is to postpone the point at which myocardial ischemia occurs beyond that at which exhaustion limits the exercise test. As a result, exercise may need to be stopped before perceptible wall motion abnormalities (or a decrease in ejection fraction) can be induced.

Calcium channel blockers predominately act by improving the ratio of myocardial oxygen supply to demand, but additional mechanisms such as changes in perfusion or myocardial metabolism may be involved.

With nitrates four different actions may be involved: (a) reduction in venous tone resulting in fall in left ventricular preload and reduced oxygen demand, (b) reduction in systolic blood pressure resulting in reduced oxygen demand, (c) relaxation of smooth muscle tone in the diseased vessel, and (d) dilatation of collateral blood vessels.

Management: Discontinue β -blocker therapy prior to radionuclide ventriculography in patients being evaluated for coronary artery disease; therapy should be tapered off over several days to prevent rebound complications. The appropriate delay between discontinuation of therapy and performance of the study should be considered; 48 hours is suggested (1).

Discontinue calcium channel blockers and nitrate therapy prior to radionuclide ventriculography in patients being evaluated for CAD. The recommended time intervals between withdrawal of medications and the nuclear medicine study is 48–72 hours for the calcium channel blockers and 12 hours for the nitrates (2).

How documented: Letter to editor (1); review (2); clinical studies (3–11).

REFERENCES

1. Ponto JA, Holmes KA: Discontinuation of beta blockers before exercise radionuclide ventriculograms. *J Nucl Med* 23:456–457, 1982.
2. Rabinovitch MA: Pharmacologic interventions in nuclear cardiology. In Thrall JH, Swanson DP (eds): *Diagnostic Interventions in Nuclear Medicine*. Chicago, Year Book Medical Publishers, 1985, pp 31–59.
3. Battler A, Ross J, Slutsky R, et al: Improvement of exercise induced left ventricular dysfunction with oral propranolol in patients with coronary heart disease. *Am J Cardiol* 44:318–324, 1979.
4. Marshall RC, Wisenberg G, Schelbert HR, et al: Effect of oral propranolol on rest, exercise and postexercise left ventricular performance in normal subjects and patients with coronary artery disease. *Circulation* 63:572–583, 1981.
5. Rainwater J, Steele P, Kirch D, et al: Effect of propranolol on myocardial perfusion images and exercise ejection fractions in men with coronary artery disease. *Circulation* 65:77–81, 1982.
6. Borer JS, Bacharach SL, Green MV, et al: Effect of nitroglycerine on exercise-induced abnormalities of left ventricular regional function and ejection fraction in coronary artery disease: assessment by radionuclide cineangiography in symptomatic and asymptomatic patients. *Circulation* 57:314–320, 1978.
7. Petru MA, Crawford MH, Sorensen SG, et al: Short- and long-term efficacy of high-dose oral diltiazem for angina due to coronary artery disease: a placebo-controlled, randomized, double-blind crossover study. *Circulation* 68:139–147, 1983.
8. Tan ATH, Sadick N, Kelly DT, et al: Verapamil in stable effort angina: effects on left ventricular function evaluated with exercise radionuclide ventriculography. *Am J Cardiol* 49:425–430, 1982.
9. Pfisterer M, Glans L, Burkart F: Comparative effects of nitroglycerin, nifedipine, and metoprolol on regional left ventricular function in patients with one-vessel coronary disease. *Circulation* 67:291–301, 1983.
10. Josephson MA, Hecht HS, Hopkins J, et al: Comparative effects of oral verapamil and propranolol on exercise-induced ischemia and energetics in patients with coronary artery disease—single blind-crossover evaluation using radionuclides. *Am Heart J* 103:978–985, 1982.
11. Hecht HS, Chew CYC, Bumam MH, et al: Verapamil in chronic stable angina: amelioration of pacing-induced abnormalities of left ventricular ejection frac-

tion, regional wall motion, lactate metabolism, and hemodynamics. *Am J Cardiol* 48:536–544, 1981.

Interfering drug(s): Heparin; methyldopa; hydralazine; quinidine; digoxin; prazosin; propranolol; doxorubicin; iodinated contrast media.

Nuclear medicine study affected: Radionuclide ventriculography; gastrointestinal (GI) blood loss scintigraphy.

Effect on image: Poor radiolabeling of red blood cells (RBC) with ^{99m}Tc or postlabeling dissociation of ^{99m}Tc from the RBC can cause a deterioration in the distinctness of the cardiac chamber border on ventriculograms and can increase the likelihood that free [^{99m}Tc]pertechnetate will appear as gastric or bowel activity on GI bleed studies.

Significance: The diminution in ability to visualize the cardiac chamber border can complicate the diagnosis of wall motion abnormalities and the calculation of ejection fraction. Furthermore, progressive loss of ^{99m}Tc from the RBC can particularly affect stress tests which usually are performed toward the end of the scanning period. If by this time the counting rate over the heart chambers has fallen considerably, a useful scan can be obtained only by keeping the patient under stress for a long period of time.

Additionally, the gastric and bowel activity seen on GI bleed studies may be confused with sites of bleeding.

Mechanism: Although therapy with the drugs listed above may produce the same net result (reduced labeling efficiency of ^{99m}Tc -labeled RBC or dissociation of the label from the RBC), the proposed mechanisms are widely varying.

With heparin, a ^{99m}Tc -labeled heparin complex may be formed as ^{99m}Tc is injected through a heparinized catheter (which was previously used for injection of pyrophosphate containing stannous ion). It is not positively known at this time whether therapeutic levels of heparin can be radiolabeled in a similar manner in vivo if stannous ion is present. One study in dogs showed that red cell labeling may be marginally affected by the previous injection of a single therapeutic dose of heparin.

It is proposed that methyldopa and hydralazine may affect the labeling efficiency of ^{99m}Tc -labeled RBC by oxidizing stannous ion in

vivo, thus decreasing the reductive capacity of tin.

Quinidine and methyldopa are medications which have been associated with RBC antibody formation; the presence of these RBC antibodies may be responsible, in part, for poor labeling of RBC in vivo with ^{99m}Tc .

Conflicting data are available on whether digoxin has an effect on labeling yield; the mechanism is unknown. Likewise, the mechanism for the effects of prazosin and propranolol is unknown. Apparently propranolol causes an increased rate of release of ^{99m}Tc from the RBC back into the plasma but does not inhibit the initial radiolabeling process.

Although it is not clear how doxorubicin causes a decrease in labeling efficiency, it appears that the effect of the drug is dependent on its concentration in the blood at the time that the study is performed.

The mechanism for interaction of iodinated contrast media with RBC labeling by ^{99m}Tc has not yet been determined. Possibilities include: (a) alteration of redox potential of either the stannous ion or technetium species present, (b) a change in stannous ion distribution, e.g., an alteration in the intracellular stannous ion concentration, (c) a competition for RBC-binding sites between ^{99m}Tc and iodide, or (d) an alteration of RBC-binding sites by iodide.

Management: Whenever it is possible, avoid injection of Sn-pyrophosphate and [^{99m}Tc]pertechnetate through a heparin lock. Do not perform radionuclide ventriculography or GI bleed studies on the same day that doxorubicin is administered. Schedule procedures requiring RBC labeling prior to studies requiring iodinated contrast media. If it is clinically feasible, discontinue use of potentially interfering drugs prior to performing RBC labeling.

How documented: Studies with in vitro models (1–4); study in rats (5); study in dogs (6); prospective clinical studies (1,7,8); case reports (9).

REFERENCES

1. Leitt GP, Drew HMN, Kelly ME, et al: Interference with Tc-^{99m} labeling of red blood cells (RBCs) by RBC antibodies. *J Nucl Med* 21:P44, 1980.
2. Zimmer AM, Spics SM, Majewski W: Effect of drugs on in vivo RBC labeling: a proposed mechanism of

inhibition. Presented at the Second International Symposium on Radiopharmacology, Chicago, September 1981.

- Zanelli GD: Effect of certain drugs used in the treatment of cardiovascular disease on the 'in vitro' labeling of red blood cells with Tc-99m. *Nucl Med Commun* 3:155-161, 1982.
- Pauwels EKJ, Feitsma RIJ, Blom J: Influence of adriamycin on red blood cell labeling: a pitfall in scintigraphic blood pool imaging. *Nucl Med Commun* 4:290-295, 1983.
- Lee HB, Wexler JP, Scharf SC, et al: Pharmacologic alterations in Tc-99m binding by red blood cells: concise communication. *J Nucl Med* 24:397-401, 1983.
- Rao SA, Knobel J, Collier BD: Effect of therapeutic dose of heparin on the in vivo labeling of red blood cells with technetium 99m for blood pool imaging: importance of stannous ion concentration. *J Nucl Med* 26:P95-P96, 1985.
- Hegge FN, Hamilton GW, Larson SM, et al: Cardiac chamber imaging: a comparison of red blood cells labeled with Tc-99m in vitro and in vivo. *J Nucl Med* 19:129-134, 1978.
- Seawright SJ, Maton PJ, Greenall J, et al: Factors affecting in vivo labeling of red blood cells. *J Nucl Med Technol* 11:95, 1983.
- Tatum JL, Burke TS, Hirsch JJ, et al: Pitfall to modified in vivo method of technetium-99m red blood cell labeling-iodinated contrast media. *Clin Nucl Med* 8: 585-587, 1983.

Interfering drug(s): Doxorubicin.

Nuclear medicine study affected: Radionuclide ventriculography.

Effect on image: Abnormal ejection fraction, reduced left ventricular function.

Significance: Radionuclide ventriculography often is used to monitor doxorubicin-induced cardiac toxicity. This effect, however, may interfere with the differential diagnosis of abnormal cardiac function.

Mechanism: Doxorubicin causes a dose-related cardiotoxicity (cardiomyopathy).

Management: None; a baseline radionuclide ventriculogram should be performed prior to initiation of doxorubicin therapy to identify undiagnosed heart disease.

How documented: Study in rabbits (1); clinical studies (2-8).

REFERENCES

- Gorton SJ, Wilson GA, Sutherland R, et al: The predictive value of myocardial radioisotope scanning in animals treated with doxorubicin. *J Nucl Med* 21:518-522, 1980.
- Singer JW, Narahara KA, Ritchie JL, et al: Time- and

dose-dependent changes in ejection fraction determined by radionuclide angiography after anthracycline therapy. *Cancer Treat Rep* 62:945-948, 1978.

- Feiglan DH, Gulenchyn KY, McLaughlin PR, et al: Adriamycin cardiotoxicity: correlation of radionuclide angiography and pathology. *J Nucl Med* 21:P74, 1980.
- Alexander J, Dainiak N, Berger HJ, et al: Serial assessment of doxorubicin cardiotoxicity with quantitative radionuclide angiocardiology. *N Engl J Med* 300:278-283, 1979.
- Druck M, Bar-Shlomo B, Gulenchyn K, et al: Radionuclide angiography and endomyocardial biopsy in the assessment of doxorubicin cardiotoxicity. *Am J Cardiol* 47:401, 1981.
- Morgan GW, McIlveen BM, Freedman A, et al: Radionuclide ejection fraction in doxorubicin cardiotoxicity. *Cancer Treat Rep* 65:629-638, 1981.
- McKillop JH, Bristow MR, Goris ML, et al: Sensitivity and specificity of radionuclide ejection fractions in doxorubicin cardiotoxicity. *Am Heart J* 106:1048-1056, 1983.
- Berger HJ, Choi W, Alexander J, et al: Serial radionuclide evaluation of doxorubicin cardiotoxicity in cancer patients with abnormal baseline resting left ventricular ejection fraction. *J Nucl Med* 22:P40, 1981.

¹¹¹IN-DTPA AND ¹⁶⁹YB-DTPA

Interfering drug(s): Acetazolamide

Nuclear medicine study affected: Cisternography.

Effect on image: Delayed parasagittal migration of radiotracer with reflux of tracer into the ventricles (in the absence of disease).

Significance: This pattern of distribution mimics that typically observed in patients with normal pressure hydrocephalus.

Mechanism: Acetazolamide induces a vasoconstriction of the choroid plexus arteries and inhibits the enzyme carbonic anhydrase. Both of these phenomenon tend to decrease the production of cerebral spinal fluid (CSF) which, in turn, alters CSF kinetics. The reduced outflow of CSF from the ventricles results in net reflux of radiotracer into the ventricles.

Management: Discontinue therapy with acetazolamide several days prior to performing the cisternography study.

How documented: Case report, before and after discontinuation of acetazolamide (1).

REFERENCE

- Papancolaou N, McNeil BJ, Funkenstein HH, et al: Abnormal cisternogram associated with Diamox therapy. *J Nucl Med* 19:501-503, 1978.

¹¹¹IN-LABELED LEUKOCYTES

Interfering drug(s): Antibiotics; corticosteroids; hyperalimentation; lidocaine; procainamide.

Nuclear medicine study affected: Inflammatory process scintigraphy.

Effect on image: Reduced or absent uptake of radiotracer into abscess.

Significance: Interference from antibiotic and corticosteroid drugs as well as hyperalimentation may result in false negative studies. It is obvious, however, that drug therapy does not always alter the distribution of radiolabeled leukocytes, since many positive scans are obtained in patients receiving antibiotics or steroids.

With respect to lidocaine and procainamide, a clinical study reported that a number of negative imaging procedures were obtained in patients, all of whom had received antiarrhythmic drugs. A subsequent in vitro study, however, demonstrated no effect on leukocyte function at normal therapeutic drug concentrations.

Mechanism: Drug therapy with antibiotics, corticosteroids, or hyperalimentation may result in a reduced chemoattractant stimuli for the radiolabeled leukocytes. Additionally, cationic antiarrhythmic drugs in higher-than-therapeutic concentrations have been shown to inhibit a number of granulocyte functions including chemotaxis (1).

Management: None.

How documented: Observations made in clinical studies and in vitro experiments (1-6); a review editorial (7).

REFERENCES

- MacGregor RR, Thomer RE, Wright DM: Lidocaine inhibits granulocyte adherence and prevents granulocyte delivery to inflammatory sites. *Blood* 56:203-209, 1980.
- Loken MK, Forstram LA, Cook A, et al: In-111 labeled leukocytes for diagnosing inflammatory diseases of the abdomen and retroperitoneum. In Wahner HW, Goodwin DA (eds): *111-Indium Labeled Platelets and Leukocytes*. Crystal Lake, IL, Society of Nuclear Medicine, 1981, pp 145-159.
- Baker WJ, Beightol RW, Datz FL, et al: 111-Indium oxine labeled leukocytes: a discussion of the preparation and use at the University of Utah. Presented at the 128th Annual Meeting of the American Pharmaceutical Association Academy of Pharmacy Practice, St. Louis, March 1981.

- Thompson L, Ouzounian TJ, Webber MM, et al: In-111 WBC imaging in musculoskeletal sepsis. *J Nucl Med* 25:P52, 1984.
- Aschner NL, Ahrenholz DH, Simmons RL, et al: In-111 autologous tagged leukocytes in the diagnosis of intra-peritoneal sepsis. *Arch Surg* 114:386-392, 1979.
- Thakur ML, Walsh LJ, Zaret BL, et al: Effect of antiarrhythmic drugs on In-111-labeled leukocytes: chemotaxis and adherence to nylon wool. *J Nucl Med* 23:131-135, 1982.
- Goodwin DA: Clinical use of in-111 leukocyte imaging. *Clin Nucl Med* 8:36-38, 1983.

Interfering drug(s): Antibiotics (e.g., penicillin).

Nuclear medicine study affected: Inflammatory process scintigraphy.

Effect on image: Visualization of colon.

Significance: Drug-induced accumulation of ¹¹¹In-labeled leukocytes in the colon could mimic a pattern of distribution observed in patients with inflammatory bowel disease not related to drug therapy.

Mechanism: Certain antibiotics are known to cause pseudomembranous colitis, an inflammatory disease that may attract ¹¹¹In-labeled leukocytes.

Management: None; however, the drug responsible for inducing the colitis should be discontinued and replaced with alternative therapy.

How documented: Case report (1).

REFERENCE

- Bushnell DL: Detection of pseudomembranous colitis with indium-111 labeled leukocyte scintigraphy. *Clin Nucl Med* 9:294-295, 1984.

¹¹¹IN-LABELED PLATELETS

Interfering drug(s): Heparin.

Nuclear medicine study affected: Pulmonary embolus scintigraphy.

Effect on image: Full-dose heparin therapy may result in the failure of ¹¹¹In-labeled platelets to identify sites of pulmonary emboli.

Significance: The ability of heparin to cause false negative studies decreases the usefulness of ¹¹¹In platelets for the detection of pulmonary emboli.

Mechanism: Heparin inhibits the adherence of platelets to experimental pulmonary emboli, possibly due to interference with the thrombin-platelet interaction (1).

Management: Perform scintigraphy prior to initial anticoagulation or in conjunction with interruption of heparin therapy.

How documented: Study in dogs (2); observations made in clinical studies (2,3).

REFERENCES

1. Thomas DP, Gurewich V, Ashford TP: Platelet adherence to thromboemboli in relation to the pathogenesis and treatment of pulmonary embolism. *N Engl J Med* 274:953-956, 1966.
2. Sostman HD, Neumann RD, Zoghbi SS, et al: Clinical and experimental studies of pulmonary embolism using ¹¹¹indium labeled platelets. *Invest Radiol* 16:392, 1981.
3. Davis HH II, Siegel BA, Sherman LA, et al: Scintigraphy with ¹¹¹In labeled autologous platelets in venous thromboembolism. *Radiology* 136:203-207, 1980.

SODIUM [¹²³I]IODIDE AND SODIUM [¹³¹I]IODIDE

Interfering drug(s): See list below in "management" section.

Nuclear medicine study affected: Radioiodine thyroid uptake study.

Effect on image: Decreased uptake of radioiodine.

Significance: In hyperthyroid patients, certain drugs may decrease thyroid uptake into the normal uptake range, thus giving false negative results. In normothyroid patients, a drug-induced reduction in thyroid uptake may result in a diagnosis of hypothyroidism (false positive). In addition, a rebound increased uptake is conceivable following the discontinuation of some of these drugs.

Mechanism: Antithyroid drugs inhibit the metabolic synthesis of thyroid hormones, resulting in decreased iodide transport. Specifically, they interfere with the incorporation of iodide into tyrosyl residues of thyroglobulin and inhibit the coupling of the iodotyrosyl residues to form iodothyronine. Moreover, these drugs may interfere with the oxidation of iodide ion and iodotyrosyl groups.

Natural or synthetic thyroid preparations act by suppressing the secretion of thyrotropin (TSH). Phenylbutazone also may inhibit TSH release.

Vitamins, antitussives, expectorants, and topical medications that contain various iodide salts can decrease thyroid uptake by diluting the vascular pool of radioiodide, thus decreasing the specific activity of the radioiodine in the

circulating body pool. Iodinated contrast media release iodide over a period of time, resulting in the same type of effect.

Chronic salicylate administration causes a depression of thyroid function, presumably via the pituitary or higher centers.

Sodium nitroprusside lowers uptake of radioiodine because of the action of its metabolic by-product, thiocyanate, to inhibit the thyroidal iodide-trapping mechanism.

Steroids may affect the thyroid uptake by suppressing TSH formation, through a direct inhibitory effect on the thyroid itself or by increasing renal radioiodine clearance.

Benzodiazepines may depress thyroid uptake of iodine through some direct antithyroid effect which has not been clearly elucidated.

Management: A drug history should be taken before the uptake study is performed. If interfering drugs are part of the patient's current therapeutic regimen, these drugs must be withheld for an appropriate time period (Table 14.1) before the uptake procedure is attempted.

Table 14.1.

Time to Withhold Therapy Prior to Initiation of Uptake Study

Type of Medication	Time
Antithyroid (propylthiouracil, Tapazole)	1 week
Natural or synthetic thyroid preparations (Synthroid, Cytomel, Thyrolar)	2-3 weeks
Expectorants, vitamins	2 weeks
Phenylbutazone	1-2 weeks
Salicylates	1 week
Steroids	1 week
Sodium nitroprusside	1 week
Miscellaneous agents:	1 week
Anticoagulants	
Antihistamines	
Antiparasitics	
Penicillins	
Sulfonamides	
Tolbutamide	
Thiopental	
Benzodiazepines	4 weeks
Topical iodides	1-9 months
Intravenous contrast agents	1-2 months
Oral cholecystographic agents	6-9 months
Oil-based iodinated contrast agents:	
Bronchographic	6-12 months
Myelographic	2-10 years

How documented: Various animal and clinical studies (1-27); review articles and chapters (28-30).

REFERENCES

1. Greer MA: The effect on endogenous thyroid activity of feeding desiccated thyroid to normal human subjects. *N Engl J Med* 244:385-390, 1951.
2. Ceccarelli C, Grasso L, Martino E: Re: reduction of thyroid uptake by iodine absorbed with eye-drop therapy. *J Nucl Med* 23:364-365, 1982.
3. Pochin EE, Barnaby CF: The effect of pharmacological doses of non-radioactive iodide on the course of radioiodine uptake by the thyroid. *Health Phys* 7:125-126, 1962.
4. Slingerland DW: Influence of various factors on uptake of iodine by thyroid. *J Clin Endocrinol* 15:131-141, 1955.
5. Austen FK, Rubini ME, Meroney WH, et al: Salicylates and thyroid function. I. Depression of the thyroid function. *J Clin Invest* 37:1131-1143, 1958.
6. Coel N, Talner B, Lang H: Mechanism of radioactive iodine uptake following intravenous urography. *Br J Radiol* 48:146-147, 1975.
7. Hurley JR, Becker DV: Thyroid suppression and stimulation testing: the place of scanning in the evaluation of nodular thyroid disease. *Semin Nucl Med* 11:149-160, 1981.
8. Hannigren A: Determination of the antithyroid action of para-aminosalicylic acid using radioactive iodine. *Lancet* 2:117, 1952.
9. Linsk J, Paton BC, Persky M, et al: The effect of phenylbutazone and related analogue (G25671) upon thyroid function. *J Clin Endocrinol* 17:416-423, 1957.
10. Scott KG, Frerichs JB, Riehlly WA: Effect of butazolidin upon the fate of I-131 in the rat. *Proc Soc Exp Biol Med* 82:150-152, 1953.
11. Friedell MT: Effect of tranquilizing agents on radioactive iodine uptake in the thyroid gland. *JAMA* 167:983-985, 1958.
12. Samel M: Blocking effect of morphine on the secretion of thyroid-stimulating hormone in rats. *Nature* 181:845-846, 1958.
13. Yohalem SB: Use of meprobramate (Equanil) in hyperthyroidism. *NY State J Med* 57:2518, 1957.
14. Nourouk DS, Glasscock RJ, Solomon DH, et al: Hypothyroidism following prolonged sodium nitroprusside therapy. *Am J Med Sci* 248:129-136, 1964.
15. Wyngaarden JB, Wright BM, Ways R: The effect of certain anions upon the accumulation and retention of iodide by the thyroid gland. *Endocrinology* 50:537-549, 1952.
16. Godley AF, Stanbury JB: Preliminary experience in the treatment of hyperthyroidism with potassium perchlorate. *J Clin Endocrinol* 14:70, 1954.
17. Kelsey FO, Gullock AH, Kelsey FE: Thyroid activity in hospitalized psychiatric patients—relation of dietary iodine to I-131 uptake. *Arch Neurol Psychiat* 77:543-548, 1957.
18. Kohn LA, Nichols EB: Interference with uptake of radioiodine tracer during administration of vitamin-mineral mixtures. *N Engl J Med* 253:286-287, 1955.
19. Clark RE, Shipley RA: Thyroidal uptake of ¹³¹I after iopanoic acid (Telepaque) in 74 subjects. *J Clin Endocrinol* 17:1008, 1957.
20. Thomas JD, Oddie TH, Myhill J: A diagnostic radioiodine uptake test in patients receiving antithyroid drugs. *J Clin Endocrinol Metab* 20:1601-1607, 1960.
21. Stanley MM, Astwood EB: The accumulation of radioactive iodide by the thyroid gland in normal thyrotoxic subjects and the effect of thiocyanate on its discharge. *Endocrinology* 42:107, 1948.
22. Levy RP, Marshall JS: Short-term drug effects on thyroid function tests. *Arch Intern Med* 114:413-416, 1964.
23. Wood DE, Gilday DL, Eng B, et al: Stable iodine requirements for thyroid gland blockage of iodinated radiopharmaceuticals. *J Can Assoc Radiol* 25:295-296, 1974.
24. Magalotti MF, et al: Effect of disease and drugs on twenty-four hour ¹³¹I thyroid uptake. *AJR* 81:47, 1959.
25. Sternthal E, Lipworth L, Stanley B, et al: Suppression of thyroid radioiodine uptake by various doses of stable iodide. *N Engl J Med* 303:1083-1088, 1980.
26. Ogunleye OT, Ejiwunmi AB: Influence of diazepam on thyroid function tests in normal Nigerians. *Int J Nucl Med Biol* 11:203-204, 1984.
27. Hankins JH, Heise CM, Cowan RJ: Iatrogenic hyperthyroidism secondary to dextrothyroxine administration. *Clin Nucl Med* 9:17-19, 1984.
28. Grayson RR: Factors which influence the radioactive iodine thyroidal uptake test. *Am J Med* 28:397-415, 1960.
29. Haden HT: Thyroid function tests, physiologic basis and clinical interpretation. *Postgrad Med* 40:129-137, 1966.
30. Mettler FA, Guiberteau MJ (eds): *Essentials of Nuclear Medicine Imaging*, ed 2. New York, Grune & Stratton, 1986.

[¹³¹I]Iodomethylcholesterol

Interfering drug(s): Spironolactone; other diuretics.

Nuclear medicine study affected: Adrenal cortex scintigraphy.

Effect on image: Bilateral adrenal uptake of radiotracer (in patients with unilateral disease).

Significance: Bilateral uptake of radiotracer frequently occurs in patients with aldosteronoma who are receiving chronic spironolactone or other diuretic therapy. Therefore, administration of these drugs may result in an incorrect differentiation between unilateral adenoma and bilateral hyperplasia with use of adrenal scintigraphy, even when dexamethasone suppression is utilized.

Mechanism: Diuretics decrease serum sodium and plasma volume, resulting in increased activity of the renin-angiotensin system. A specialized diuretic, spironolactone, competitively inhibits the sodium and chloride reabsorption action of aldosterone on the renal tubules, which also results in increased activity of the renin-angiotensin system. This increase in plasma renin activity stimulates the zona glomerulosa to synthesize and secrete aldosterone which results in an increased localization of radiotracer in the normal adrenal gland. In the presence of an aldosteronoma, the increase in uptake induced by diuretics would be in the contralateral gland, resulting in bilateral uptake of the radiotracer and, therefore, a false negative scan. (Spironolactone also acts as a direct adrenal glomerulosa antagonist. If the drug is given over a long enough period, it would suppress aldosterone biosynthesis and secretion and, therefore, probably suppress uptake of [¹³¹I]iodomethylnorcholesterol into the adrenal cortex. This would obviously change the pattern of distribution from that noted above.)

Management: If it is clinically feasible, discontinue diuretic therapy prior to performing adrenal scintigraphy.

How documented: Prospective clinical study (1); observations reported in review article (2).

REFERENCES

1. Fischer M, Vetter W, Wintger B, et al: Adrenal scintigraphy in primary aldosteronism. Spironolactone as a cause of incorrect classification between adenoma and hyperplasia. *Eur J Nucl Med* 7:222-224, 1982.
2. Gross MD, Valk TW, Swanson DP, et al: The role of pharmacologic manipulation in adrenal cortical scintigraphy. *Semin Nucl Med* 11:128-148, 1981.

Interfering drug(s): Oral contraceptives.

Nuclear medicine study affected: Adrenal cortex scintigraphy.

Effect on image: Early bilateral visualization of the adrenals is observed in individuals with no adrenal disease or with unilateral disease only, despite dexamethasone suppression.

Significance: This interaction must particularly be considered in the evaluation of women with hyperandrogenism, since oral contraceptives are often incorporated into their therapeutic regimen. If the site of abnormal androgen produc-

tion is, indeed, outside of the adrenals, the early bilateral visualization of radioactivity in the adrenal glands may be falsely interpreted as bilateral adrenal hyperplasia. This pattern of distribution could also mask an adrenal adenoma, which could be a source of excess androgen production.

Mechanism: Oral contraceptives increase the adrenal uptake of [¹³¹I]iodomethylnorcholesterol by producing an elevation of plasma renin activity which results in adrenal cortical stimulation, increased cortisol secretion, and a "functional hyperplasia."

Management: Discontinue oral contraceptive therapy if it is necessary to use [¹³¹I]iodomethylnorcholesterol for determining the contribution of the adrenal glands to excess androgen output.

How documented: Clinical observations reported in review articles (1,2).

REFERENCES

1. Gross MD, Thrall JH, Beierwaltes WH: The adrenal scan: a current status report on radiotracers, dosimetry and clinical utility. In Freeman LM, Weissman HS (eds): *Nuclear Medicine Annual 1980*. New York, Raven Press, 1980, pp 127-175.
2. Gross MD, Valk TW, Swanson DP, et al: The role of pharmacologic manipulation in adrenal cortical scintigraphy. *Semin Nucl Med* 11:128-148, 1981.

m-[¹³¹I]IODOBENZYLGUANIDINE (mIBG)

Interfering drug(s): Tricyclic antidepressants; reserpine; sympathomimetics.

Nuclear medicine study affected: Adrenal medullary scintigraphy.

Effect on image: An absence of uptake by the salivary glands and the heart has been observed in a few patients taking either imipramine, doxepin, or Entex, a nasal decongestant containing both phenylephrine and phenylpropanolamine. For the most part, however, patients taking tricyclic antidepressants (or reserpine) have been intentionally excluded from scintigraphic protocols during clinical trials with [¹³¹I]-mIBG. Therefore, the effect of these drugs on uptake of [¹³¹I]-mIBG into human pheochromocytomas has not been established.

In animal models, reserpine consistently reduces the adrenomedullary uptake of [¹³¹I]-

mIBG. There are, however, conflicting animal data concerning the effect of desmethylimipramine. In dogs, the uptake of [¹³¹I]-mIBG was markedly affected by desmethylimipramine, but in rats, an effect was not observed. Pretreatment of rats with sympathomimetic drugs results in large decreases in radiotracer concentration in adrenergic-rich tissues such as the left atrium, left ventricle, spleen, and parotid glands.

Significance: The diagnosis of pheochromocytoma with use of [¹³¹I]-mIBG scintigraphy may be adversely affected if these drugs do inhibit uptake of the radiotracer into the tumor; more data are necessary, however, to determine the true significance. Moreover, the effects of these drugs on [¹³¹I]-mIBG scintigraphy of the heart must be considered.

Mechanism: Studies indicate that [¹³¹I]-mIBG enters adrenergic tissue and is stored in granules of the adrenal medulla by mechanisms similar to those for the neurotransmitter norepinephrine. Reserpine and tricyclic antidepressants interfere with uptake of norepinephrine (and mIBG) by adrenergic tissues and, theoretically, may reduce the detectability of pheochromocytomas. Sympathomimetic agents may act by causing a release of norepinephrine (and mIBG) from storage sites, thus decreasing the accumulation of mIBG in adrenergic neurons.

Management: If it is clinically appropriate, discontinue drugs prior to performing adrenal medullary scintigraphy.

How documented: Study in rats (1,2); study in mice (2); studies in dogs (2-5); case reports (5); observations from clinical study (6).

REFERENCES

1. Sherman PS, Fisher SJ, Wieland DM, et al: Over the counter drugs block heart accumulation of MIBG. *J Nucl Med* 26:P35, 1985.
2. Guilloteau D, Baulieu JL, Huguet F, et al: Metaiodobenzylguanidine adrenal medulla localization: Autoradiographic and pharmacologic studies. *Eur J Nucl Med* 9:278-281, 1984.
3. Wieland DM, Brown LE, Tobes MC, et al: Imaging the primate adrenal medulla with I-123 and I-131 metaiodobenzylguanidine: concise communication. *J Nucl Med* 22:358-364, 1981.
4. Wieland DM, Brown LE, Marsh DD, et al: The mechanism of MIBG in localization: drug intervention studies. *J Nucl Med* 22:P20, 1981.

5. Shapiro R, Wieland DM, Brown LE, et al: [¹³¹I]-metaiodobenzylguanidine (MIBG) adrenal medullary scintigraphy: interventional studies. In Spencer R (ed): *Interventional Nuclear Medicine*. New York, Grune & Stratton, 1984, pp 451-481.

6. Sisson JC, Frager MS, Valk TW, et al: Scintigraphic localization of pheochromocytoma. *N Engl J Med* 305:12-17, 1981.

[²⁰¹Tl]THALLOUS CHLORIDE

Interfering drug(s): β -Adrenergic blockers (e.g., propranolol); nitrates (isosorbide dinitrate).

Nuclear medicine study affected: Myocardial perfusion scintigraphy.

Effect on image: Clinically, these drugs tend to decrease the number and size of exercise-induced [²⁰¹Tl]thallous chloride perfusion defects. (²⁰¹Tl studies performed in resting dogs indicate that propranolol favors a redistribution of [²⁰¹Tl]thallous chloride in ischemic myocardial regions toward the subendocardial layers, which is beneficial, since myocardial ischemia always originates in the subendocardial layers and subsequently spreads out to the epicardium (1). If propranolol has the same effect at exercise, it may help to explain the phenomenon observed clinically.)

Significance: False negative exercise [²⁰¹Tl]thallous chloride scans can occur in patients receiving β -blocker or nitrate therapy who are being evaluated for CAD. Underestimation of the severity of CAD can result in inadequate or inappropriate therapeutic measures.

Mechanism: Two possible mechanisms may be responsible for the effects of β -blocking agents. First, the effects may result from drug-induced changes in the exercise performance of patients. The administration of a β -blocker blunts the normal rise in heart rate and systolic blood pressure which occurs with exercise, resulting in a reduction in myocardial oxygen consumption. In addition, β -blockers may increase myocardial oxygen extraction and augment stroke volume despite a tendency for the cardiac output to decrease. The overall effect of these changes on exercise ability depends on the underlying function of the left ventricle. Patients with CAD and impaired left ventricular function typically show a greater and more consistent

increase in exercise performance than do individuals without CAD. The net effect of β -blockade therapy on exercise [^{201}Tl]thallous chloride scintigraphy is to postpone the point at which myocardial ischemia occurs beyond that at which exhaustion limits the exercise test. As a result, exercise may need to be stopped before perceptible perfusion defects can be induced.

Nitrates may cause a beneficial redistribution of coronary blood flow, resulting in decreased myocardial ischemia. Nitroglycerin, for instance, has been shown to preferentially increase subendocardial blood flow. Redistribution of coronary blood flow may occur because the nitrates preferentially dilate the large conductance vessels rather than the arteriolar resistance vessels, which results in shunting of blood to the ischemic myocardium. In addition, collateral vessels which develop secondary to myocardial ischemia may be dilated by these drugs.

Management: Discontinue β -blocker therapy 48 hours prior to performance of study (by tapering dosage); also discontinue nitrate therapy prior to study.

How documented: A study in dogs investigated the distribution of [^{201}Tl]thallous chloride in normal and ischemic myocardium (1). Several researchers have used various animal models to study the effect of propranolol on uptake of [^{201}Tl]thallous chloride into the normal myocardium; results range from a slight decrease in uptake to no significant change caused by the drug (1–6). One retrospective clinical study showed that propranolol apparently did not alter the myocardial-to-background ratio of ^{201}Tl (7). Other clinical studies, however, have documented that the sensitivity of exercise [^{201}Tl]thallous chloride imaging is reduced in patients taking propranolol (8–12). At least one clinical study has reported a similar loss of sensitivity following isosorbide dinitrate therapy (13).

REFERENCES

- van der Wall EE, Westera G, van Eenige MJ, et al: Influence of propranolol on uptake of radioiodinated heptadecanoic acid and thallium-201 in the dog heart. *Eur J Nucl Med* 8:454–457, 1983.
- Hamilton GW, Narahara KA, Yee H, et al: Myocardial imaging with thallium-201: effect of cardiac drugs on

myocardial images and absolute tissue distribution. *J Nucl Med* 19:10–16, 1978.

- Zaret BL: Radionuclide imaging of myocardial ischemia and infarction. *Circulation* 53(Suppl): 1126–1128, 1976.
- Shelbert H, Ingwall J, Watson R, et al: Factors influencing the myocardial uptake of thallium-201. *J Nucl Med* 18:598, 1977.
- Costin JC, Zaret BL: Effect of propranolol and digitalis upon radioactive thallium and potassium uptake in myocardial and skeletal muscle. *J Nucl Med* 17:535, 1976.
- Weich HE, Strauss HW, Pitt B: The extraction of thallium-201 by the myocardium. *Circulation* 56:188–191, 1977.
- Waschek J, Hinkle G, Basmadjian G, et al: Effect of cardiac drugs on imaging studies with thallous chloride Tl 201. *Am J Hosp Pharm* 38:1726–1728, 1981.
- Hockings B, Saltissi S, Croft DN, et al: Effect of beta adrenergic blockade on thallium-201 myocardial perfusion imaging. *Br Heart J* 49:83–89, 1983.
- Henkin RE, Chang W, Provis R: The effect of beta blockers on thallium scans. *J Nucl Med* 23:P63, 1982.
- Pohost GM, Alpert NM, Ingwall JS, et al: Thallium redistribution: mechanisms and clinical utility. *Semin Nucl Med* 10:70–93, 1980.
- Albro PC, Gould KL, Westcott RJ, et al: Noninvasive assessment of coronary stenoses by myocardial imaging during pharmacologic coronary vasodilation: III. Clinical trial. *Am J Cardiol* 42:751–760, 1978.
- Osbakken MD, Okada RD, Boucher CA, et al: The effect of linal, exercise level, and subcritical disease on the specificity of exercise thallium-201 imaging. *J Nucl Med* 22:P41, 1981.
- Wolf R, Pretschner P, Engel HJ, et al: Effect of isosorbide dinitrate on 201-thallium myocardial imaging in coronary heart disease. *Am J Cardiol* 43:432, 1979.

Interfering drug(s): Vasopressin.

Nuclear medicine study affected: Myocardial perfusion scintigraphy.

Effect on image: Appearance of myocardial perfusion defects (reversible on discontinuation of drug) in patients without coronary artery disease.

Significance: Interaction is probably of minimal clinical significance, since [^{201}Tl]thallous chloride imaging rarely is performed in patients on vasopressin therapy. In those instances when this may occur, however, the clinician should be aware of the potential for false positive results. **Mechanism:** This phenomenon most likely reflects the capacity of vasopressin to increase coronary vascular resistance.

Management: Discontinue drug therapy several hours prior to performing [^{201}Tl]thallous

chloride scintigraphy, when it is clinically appropriate.

How documented: Prospective clinical study (1).

REFERENCE

- Davison R, Kaplan K, Bines A, et al: Abnormal thallium-201 scintigraphy during low-dose vasopressin infusions. Presented at the American College of Cardiology Meeting, Atlanta, April 1982.

Interfering drug(s): Propranolol; cardiac glycosides; procainamide; lidocaine; phenytoin; doxorubicin.

Nuclear medicine study affected: Myocardial perfusion scintigraphy.

Effect on image: These drugs tend to slightly decrease myocardial localization and increase liver localization of ^{201}Tl . Thus, evaluation of images that already have a relatively poor target-to-background ratio may be further compromised.

Significance: The effect of these drugs in possibly decreasing myocardial uptake of ^{201}Tl is not likely to be clinically relevant, since it is global and would not be expected to result in a change in regional ^{201}Tl concentration. Moreover, the magnitude of the effect often is so small that it is not significant. In some cases, e.g., phenytoin, heart-to-blood and heart-to-muscle ratios are changed only slightly by drug therapy, which further minimizes the clinical significance. It has been noted, however, that decreasing myocardial uptake can be associated with increasing numbers of medications used in combination.

Mechanism: The cardiac drugs probably exert their effects (if any) by altering coronary blood flow and delivery of ^{201}Tl to the myocardial cells.

Phenytoin and doxorubicin exert their effects by direct actions on the sodium-potassium activated ATPase pump and the active transport of ^{201}Tl into the myocardial cells.

Management: None.

How documented: Studies in mice (1,2), rats (3), rabbits (4), and dogs (5–7); retrospective clinical study (8).

REFERENCES

- Bossuyt A, Jonckheer MH: Noninvasive determination of the regional distribution of cardiac output: effect of

pharmacological agents on the distribution of Tl-201. *J Nucl Med* 19:973, 1978.

- Shelbert H, Ingwall J, Watson R, et al: Factors influencing the myocardial uptake of Tl-201. *J Nucl Med* 18:598, 1977.
- Schachner ER, Oster ZH, Cicale NR, et al: The effect of diphenylhydantoin (Dilantin) on thallium-201 chloride uptake. *Eur J Nucl Med* 6:585–586, 1981.
- Forst D, Sorensen S, O'Rourke R, et al: Reversibility of adriamycin induced reduction in myocardial thallium-201 uptake by intravenous digoxin. *Clin Res* 27:727A, 1979.
- Weich HF, Strauss WW, Pitt B: The extraction of thallium-201 by the myocardium. *Circulation* 56:188–191, 1977.
- Costin JC, Zaret BL: Effect of propranolol and digitalis upon radioactive thallium and potassium uptake in myocardial and skeletal muscle. *J Nucl Med* 17:535, 1976.
- Hamilton GW, Narahara KA, Yee H, et al: Myocardial imaging with thallium-201. Effect of cardiac drugs on myocardial images and absolute tissue distribution. *J Nucl Med* 19:10–16, 1978.
- Waschek J, Hinkle G, Basmadjian G, et al: Effect of cardiac drugs on imaging studies with thallous chloride Tl-201. *Am J Hosp Pharm* 38:1726–1728, 1981.

RADIOCYANOCOBALAMIN

Interfering drug(s): Parenteral vitamin B₁₂; colchicine; neomycin; *p*-aminosalicylic acid; calcium chelating agents; biguanides; anticonvulsants (phenobarbital, phenytoin, primidone); potassium; cholestyramine; cyclohexamide; dactinomycin; oral contraceptives.

Nuclear medicine study affected: Schilling test.

Effect on study: Decreased absorption of radiocyanocobalamin.

Significance: Reduced absorption results in decreased excretion of the radiotracer. In some instances, the study result may still be within normal limits; however, abnormal study results may be misinterpreted as pernicious anemia or other causes of malabsorption.

Mechanism: Drugs variably interfere with the absorption of the radiotracer.

Parenteral vitamin B₁₂: this effect is thought to be related to high concentrations of B₁₂ in the bile diluting the radioactive B₁₂ and saturating ileal-binding sites.

Aminosalicylic acid, biguanides, colchicine, ethanol, anticonvulsants, cyclohexamide: this effect is thought to be a direct action on the ileal transport of B₁₂, possibly by disturbing some folate-dependent enzyme system.

Antibiotics: this effect is thought to be related to decreased ilial mucosal binding of B₁₂ secondary to inflammatory reactions (enteritis). Other possible mechanisms include gastritis (decreased intrinsic factor production and release), increased intestinal motility, chelation of calcium ions, and bacterial superinfection.

Calcium chelating agents: this effect is due to sequestration of ionic calcium, an ion required in the absorptive mechanism for B₁₂.

Potassium: slow release potassium tablets cause acidification of intestinal contents to a pH lower than that required in the absorptive mechanism for B₁₂.

Cholestyramine: effect caused by drug binding to B₁₂-binding sites on intrinsic factor and preventing the formation of the intrinsic factor-B₁₂ complex needed for absorption.

Management: Discontinue drug therapy several days prior to initiation of Schilling test. In some cases, reversal of malabsorption can be achieved by the administration of folic acid.

How documented: Studies in rats (1-4); case reports (5-7); clinical studies (3,6,8-33); reviews (34-36).

REFERENCES

1. Yeh SDJ, Shils ME: Effect of actinomycin D and colchicine on intestinal absorption in rats. *Fed Proc* 25(2):322, 1966.
2. Findlay J, Sellers E, Forstner G: Lack of effect of alcohol on small intestinal binding of the vitamin B₁₂-intrinsic factor complex. *Can J Physiol Pharmacol* 54:469-476, 1976.
3. Okuda K, Sasayama K: Effects of ethylenediaminetetraacetate and metal ions in intestinal absorption of vitamin B₁₂ in man and rats. *Proc Soc Exp Biol Med* 120:17-20, 1965.
4. Yeh SDJ, Shils ME: Cycloheximide effect on vitamin B₁₂ absorption and intrinsic factor production in the rat. *Proc Soc Exp Biol Med* 130:1260-1264, 1969.
5. Halsted CH, McIntyre PA: Intestinal malabsorption caused by aminosalicic acid therapy. *Arch Intern Med* 130:935-939, 1972.
6. Heinivaara O, Palva IP: Malabsorption of vitamin B₁₂ during treatment with para-aminosalicylic acid. *Acta Med Scand* 175:469-471, 1964.
7. Reynolds EH, Hallpike JR, Phillips EM, et al: Reversible absorptive defects in anticonvulsant megaloblastic anemia. *J Clin Pathol* 18:593-598, 1965.
8. Jacobson ED, Chodos RB, Faloon WW: Experimental malabsorption induced by neomycin. *Am J Med* 28:524-533, 1960.
9. Gasbeck R, Nyberg W: Inhibition of radiovitamin B₁₂ absorption by ethylenediaminetetraacetate (EDTA) and

its reversal by calcium ions. *Scand J Clin Lab Invest* 10:448, 1958.

10. Webb DI, Chodos RB, Mahar CO, et al: Mechanism of vitamin B₁₂ malabsorption in patients receiving colchicine. *N Engl J Med* 279:845-850, 1968.
11. Lindenbaum J, Lieber CS: Alcohol induced malabsorption of vitamin B₁₂ in man. *Nature* 224:806, 1969.
12. Mailloux LU, Streeto JM: The effect of prior vitamin B₁₂ administration on the Schilling test. *Am J Med Sci* 250:697-699, 1965.
13. Chow BF, Okuda K: Urinary excretion test for vitamin B₁₂. *Fed Proc* 14:430, 1955.
14. Ellenbogen L, Williams WL, Rabiner SF, et al: An improved urinary excretion test as an assay for intrinsic factor. *Proc Soc Exp Biol Med* 89:357-362, 1955.
15. Breuel HP, Fischer P: The influence of vitamin B₁₂ premedication on the result of the Schilling test (author's translation). *Nuklearmedizin* 18:186-188, 1979.
16. Grames GM, Reisinger R, Jansen C, et al: Feasibility of consecutive-day Schilling tests. *J Nucl Med* 15:949-952, 1974.
17. Heinivaara O, Palva IP: Malabsorption and deficiency of vitamin B₁₂ caused by treatment with para-aminosalicylic acid. *Acta Med Scand* 177:337-341, 1965.
18. Paaby P, Norvin E: The absorption of vitamin B₁₂ during treatment with para-aminosalicylic acid. *Acta Med Scand* 180:561-564, 1966.
19. Palva IP, Rytönen V, Alatalo M, et al: Drug-induced malabsorption of vitamin B₁₂. V. Intestinal pH and absorption of vitamin B₁₂ during treatment with para-aminosalicylic acid. *Scand J Haematol* 9:5-7, 1972.
20. Toskes PP, Deren JJ: Selective inhibition of vitamin B₁₂ malabsorption by para-aminosalicylic acid. *Gastroenterology* 62:1232-1237, 1972.
21. Willms B, Creutzfeldt W: Contribution to the intestinal resorption of vitamin B₁₂ (Schilling test) and of D-xylose in biguanide treatment. *Diabetologia* 6:652, 1970.
22. Berchtold P, Dahlqvist A, Gustafson A, et al: Effects of a biguanide (metformin) on vitamin B₁₂ and folic acid absorption and intestinal enzyme activities. *Scand J Gastroenterol* 6:751-754, 1971.
23. Tomkin GH, Hadden DR, Weaver JA, et al: Vitamin B₁₂ status of patients on long-term metformin therapy. *Br Med J* 2(5763):685-687, 1971.
24. Tomkin GH: Malabsorption of vitamin B₁₂ in diabetic patients treated with phenformin: a comparison with metformin. *Br Med J* 3(5882):673-675, 1973.
25. Jounela AJ, Pirttaho H, Palva IP: Drug-induced malabsorption of vitamin B₁₂ during treatment with phenformin. *Acta Med Scand* 196:267-269, 1974.
26. Faloon WW, Chodos RB: Vitamin B₁₂ absorption studies using colchicine, neomycin and continuous ⁵⁷Co B₁₂ administration. *Gastroenterology* 56:1251, 1969.
27. Race TF, Paes IC, Faloon WW: Intestinal malabsorption induced by oral colchicine. Comparison with neomycin and cathartic agents. *Am J Med Sci* 259:32-41, 1970.
28. Salokannel SJ, Palva IP, Takkinen JT: Malabsorption of

vitamin B₁₂ during treatment with slow-release potassium chloride. *Acta Med Scand* 187:431-432, 1970.

29. Palva IP, Salokannel SJ, Timonen T, et al: Drug-induced malabsorption of vitamin B₁₂. IV. Malabsorption and deficiency of B₁₂ during treatment with slow-release potassium chloride. *Acta Med Scand* 191:355-357, 1972.
30. Palva IP, Salokannel SJ, Palva HLA, et al: Drug-induced malabsorption of vitamin B₁₂. VII. Malabsorption of B₁₂ during treatment with potassium citrate. *Acta Med Scand* 196:525-526, 1974.
31. Lees F: Radioactive vitamin B₁₂ absorption in megaloblastic anemia caused by anticonvulsant drugs. *Q J Med* 30:231-248, 1961.
32. Coronato A, Glass GBJ: Depression of the intestinal uptake of radio-vitamin B₁₂ by cholestyramine. *Proc Soc Exp Biol Med* 142:1341-1344, 1973.
33. Reisinger EH Jr, Rosenblum C, Morgan MC: Urinary excretion of orally administered Co-60 labeled vitamin B₁₂ in normal subjects and patients with pernicious anemia and sprue. *Clin Res Proc* 2:56, 1954.
34. Herbert B: Detection of malabsorption of vitamin B₁₂ due to gastric or intestinal dysfunction. *Semin Nucl Med* 2:220-234, 1972.
35. Cohen MF: Vitamin B₁₂ deficiency. *Semin Nucl Med* 11:226-227, 1981.
36. Silberstein EB: Causes of abnormalities reported in nuclear medicine testing. *J Nucl Med* 17:229-232, 1976.

RADIOXENON

Interfering drug(s): Total parenteral nutrition (TPN) therapy; clofibrate.

Nuclear medicine study affected: Pulmonary ventilation scintigraphy.

Effect on image: Appearance of radioactivity in liver during washout phase of ventilation study.

Significance: Many disorders associated with fatty liver infiltration, such as hyperlipidemias, obesity, and diabetes mellitus, can promote accumulation of radioxenon in the liver. Therefore, some confusion may arise with regard to the reason for the hepatic activity noted on a ventilation study.

Mechanism: Xenon is quite lipid soluble; hepatic retention of ¹³³Xe has been correlated with the fat and triglyceride content of the liver (1). Moreover, TPN therapy is known to cause hepatic dysfunction, including fatty liver disease, in some patients (2). In addition, certain authors have speculated that drugs such as clofibrate, which prevent hepatic breakdown of triglycerides, could be responsible for hepatic retention of radioxenon (3).

Management: None.

How documented: There are no known reports of drug-induced hepatic uptake of radioxenon, but theoretical considerations strongly support this concept (1-3).

REFERENCES

1. Kitani K, Winkler K: In vitro determination of solubility of ¹³³Xenon and ⁸⁵Krypton in human liver tissue with varying triglyceride content. *Scand J Clin Lab Invest* 29:173-176, 1972.
2. Brown RO: Total parenteral nutrition-induced liver dysfunction: a review. *Nutr Sup Serv* 2:14-16, 1982.
3. Shafer RB, Bianco JA: Implications of hepatic xenon activity in ventilation scans. *J Nucl Med* 20:450-452, 1979.

Interfering drug(s): Diazepam in sedative doses; general anesthetic agents.

Nuclear medicine study affected: Pulmonary ventilation scintigraphy.

Effect on image: The normal distribution of radioxenon in the lung (top to bottom) is shifted slightly, with more activity in the top of the lungs and less in the bottom as a result of the drug therapy.

Significance: Postoperative patients may present with changes described above.

Mechanism: Sedative and anesthetic drugs cause a reduction in the gradient of ventilation from nondependent to dependent lung.

Management: None.

How documented: Clinical studies (1, 2).

REFERENCES

1. Prato FS, Knill RL: Diazepam sedation reduces functional residual capacity and alters the distribution of ventilation in man. *Anesth Analg* 61:209-210, 1982.
2. Rehder K, Sessler AD, Marsh HM: General anesthesia and the lung. *Am Rev Respir Dis* 112:541-562, 1975.

[⁶⁷Ga]GALLIUM CITRATE

Interfering drug(s): Phenytoin.

Nuclear medicine study affected: Tumor and abscess localization scintigraphy.

Effect on image: Localization of radiogallium in the mediastinum and pulmonary hilar structures (in patients without clinical evidence of lymphadenopathy).

Significance: The induction of pseudolymphoma by phenytoin may infrequently cause false positive [⁶⁷Ga]gallium citrate scans mim-

icking a pattern of distribution sometimes observed in patients with true lymphoma. If considered from a different perspective, [⁶⁷Ga]gallium citrate imaging may be useful in identifying patients at risk from the serious side effects of phenytoin.

Mechanism: The administration of phenytoin has been associated with the development of local or generalized lymphadenopathy including benign lymph node hyperplasia, pseudolymphoma and, sometimes, even lymphoma and Hodgkin's disease.

Management: None; if this pattern of distribution (indicating lymphadenopathy) is noted on a [⁶⁷Ga]gallium citrate scan, however, the condition should be differentiated from other types of lymph node pathology and the patient observed for an extended period. Whenever possible, alternative therapy should be used.

How documented: Case report and prospective clinical study (1).

REFERENCE

1. Lentle BC, Starreveld E, Catz Z, et al: Abnormal biodistribution of radiogallium in persons treated with phenytoin. *J Can Assoc Radiol* 34:114-115, 1983.

Interfering drug(s): Amiodarone; bleomycin; busulfan; nitrofurantoin; *Bacillus Calmette-Guérin*; multiple cycles of combination chemotherapy; lymphangiographic contrast media; addictive drugs of abuse.

Nuclear medicine study affected: Tumor and abscess localization scintigraphy.

Effect on image: Diffuse pulmonary localization (and sometimes local pulmonary uptake).

Significance: This pattern of distribution mimics that observed with other diffuse pulmonary diseases not related to drug therapy, e.g., sarcoidosis. If the examiner is not familiar with toxic effects of drugs, this uptake of radiotracer in the lungs may cause some slight confusion in determining the cause of the pulmonary disorder. This is especially true considering the non-specificity of [⁶⁷Ga]gallium citrate for diagnosing any particular pulmonary disease. At times, there has been poor correlation between radiographic findings and results of [⁶⁷Ga]gallium citrate studies, which complicates matters further.

Mechanism: These drugs are known to induce pulmonary interstitial pneumonitis and/or fibro-

sis. Long-term intravenous injection of addictive drugs of abuse is associated with vascular talc granulomatosis.

Management: Discontinue therapy when drug-induced disease is detected. Schedule [⁶⁷Ga]gallium citrate studies prior to contrast lymphangiography.

How documented: Studies in mice (1-3); case reports (4-10); prospective clinical study (11); retrospective clinical studies (12,13).

REFERENCES

1. Shysh A, Mallet-Paret S, Lentle BC, et al: Altered biodistribution of radiogallium following BCG treatment in mice. *Int J Nucl Med Biol* 8:349-356, 1981.
2. Shysh A, Mallet-Paret S, Lentle BC, et al: Influence of intradermal BCG on the biodistribution of radiogallium in mice. *Int J Nucl Med Biol* 7:333-336, 1980.
3. Sasaki T, Kojima S, Kubodera A: Uptake of ⁶⁷Ga in the lung of mice during bleomycin treatment. *Eur J Nucl Med* 9:57-61, 1984.
4. van Rooij WJ, van der Meer SC, van Royen EA, et al: Pulmonary gallium-67 uptake in amiodarone pneumonitis. *J Nucl Med* 25:211-213, 1984.
5. Joelson J, Kluger J, Cole S, et al: Possible recurrence of amiodarone pulmonary toxicity following corticosteroid therapy. *Chest* 85:284-286, 1984.
6. Crook MJ, Kaplan PD, Adatepe MH: Gallium-67 scanning in nitrofurantoin-induced pulmonary reaction. *J Nucl Med* 23:690-692, 1982.
7. Richman SD, Levenson SM, Bunn PA, et al: ⁶⁷Ga accumulation in pulmonary lesions associated with bleomycin toxicity. *Cancer* 36:1966-1972, 1975.
8. Manning DM, Strimlan CV, Turbiter EH: Early detection of busulfan lung: report of a case. *Clin Nucl Med* 5:412-414, 1980.
9. MacMahon H, Bekerman C: The diagnostic significance of gallium lung uptake in patients with normal chest radiographs. *Radiology* 127:189-193, 1978.
10. Bekerman C, Hoffer PB, Bitran JD, et al: Gallium-67 citrate imaging studies of the lung. *Semin Nucl Med* 10:286-301, 1980.
11. Bilgi C, Brown NE, McPherson TA, et al: Pulmonary manifestations in patients with malignant melanoma during BCG immunotherapy. *Chest* 75:685-687, 1979.
12. Lentle BC, Castor WR, Khaliq A, et al: The effect of contrast lymphangiography on localization of ⁶⁷Ga-citrate. *J Nucl Med* 16:374-376, 1975.
13. Gupta SM, Sziklas JJ, Spencer RP, et al: Significance of diffuse pulmonary uptake in radiogallium scans: concise communication. *J Nucl Med* 21:328-332, 1980.

Interfering drug(s): Metoclopramide; reserpine; phenothiazines; oral contraceptives; diethylstilbestrol.

Nuclear medicine study affected: Tumor and abscess localization scintigraphy.

Effect on image: Localization of [⁶⁷Ga]gallium citrate in breasts (men and women).

Significance: Probably of little clinical significance, although this type of distribution is more commonly observed in postpartum or pregnant women.

Mechanism: These drugs induce gynecomastia and hyperprolactinemia which may attract [⁶⁷Ga]gallium citrate.

Management: None.

How documented: Case reports (1, 2); retrospective clinical study (3).

REFERENCES

1. Stepanas, AV, Maisey MN: Hyperprolactinaemia as a cause of gallium-67 uptake in the breast. *Br J Radiol* 49:379-380, 1976.
2. Ajmani SK, Pircher FJ: Ga-67 citrate in gynecomastia. *J Nucl Med* 19:560-561, 1978.
3. Kim YC, Brown ML, Thrall JH: Scintigraphic patterns of gallium-67 uptake in the breast. *Radiology* 124:169-175, 1977.

Interfering drug(s): Methotrexate; cisplatin; gallium nitrate; mechlorethamine; vincristine sulfate; other cancer chemotherapeutic agents; iron.

Nuclear medicine study affected: Tumor and abscess localization scintigraphy.

Effect on image: Although each report of altered biodistribution in this category varies slightly, the following items seem to be common factors observed in most instances: (a) increased skeletal uptake of [⁶⁷Ga]gallium citrate, (b) increased renal elimination of [⁶⁷Ga]gallium citrate, (c) reduced hepatic accumulation of [⁶⁷Ga]gallium citrate, and (d) reduced tumor or abscess uptake of [⁶⁷Ga]gallium citrate.

Significance: If tumor or abscess localization of the radiotracer is, indeed, decreased as a result of certain antineoplastic drugs or iron, the detectability of these lesions with [⁶⁷Ga]gallium citrate will be diminished.

Mechanism: Gallium nitrate affects the [⁶⁷Ga]gallium citrate localization through a carrier effect, i.e., competition for plasma protein-binding sites, resulting in the distribution described.

Methotrexate temporarily inhibits the incorporation of iron into erythrocytes, which results in an elevation of serum iron. The iron then competes with [⁶⁷Ga]gallium citrate for the

same plasma protein-binding sites in a manner similar to that of carrier gallium, resulting in more unbound ⁶⁷Ga. Other antimetabolite drugs, such as 5-fluorouracil, cytarabine, and 6-thioguanine, may have an effect like that of methotrexate on the kinetics of iron.

Mechlorethamine and vincristine may also decrease plasma protein binding of [⁶⁷Ga]gallium citrate, although the exact mechanism is not known.

The mechanism to explain the effect of cisplatin has not been elucidated. In vitro studies indicate, however, that reduced tumor uptake of [⁶⁷Ga]gallium citrate may be a result of intracellular biochemical changes induced by prolonged exposure to cisplatin rather than by any effect on protein binding. This concept may be applicable to other drugs. For instance, certain antineoplastic drugs may damage the specific cellular organelles that accumulate gallium. Another possibility is that chemotherapeutic agents may inhibit the uptake of [⁶⁷Ga]gallium citrate through a competitive blockade of specific receptors for gallium in certain organs and tumors.

Management: Whenever it is possible, do not administer [⁶⁷Ga]gallium citrate within 1 week of the last dose of a cancer chemotherapeutic agent or pharmacologic doses of iron. It may also be helpful to measure the patient's serum iron and iron-binding capacity before injecting [⁶⁷Ga]gallium citrate when potential problems are suspected.

How documented: In vitro study (1); study in rats (2); studies in mice (3,4); study in rabbits (5); case reports (6,7); clinical studies (8-10); review (11).

REFERENCES

1. Noujaim AA, Turner UK, Turner CJ, et al: Alterations of gallium-67 uptake in tumors by cisplatin. *Int J Nucl Med Biol* 8:289-293, 1981.
2. Fletcher JW, Herbig FK, Donati RM: ⁶⁷Ga citrate distribution following whole-body irradiation or chemotherapy. *Radiology* 117:709-712, 1975.
3. Nickel R, Levine G: A study of the effects of methotrexate and iron dextran on the distribution of Ga-67 citrate in mice. *Monthly Scan* June 1981.
4. Chilton, HM, Witcofski RL, Watson NE, et al: Alteration of gallium-67 distribution in tumor-bearing mice following treatment with methotrexate: concise communication. *J Nucl Med* 22:1064-1068, 1981.
5. Oster ZH, Larson SM, Wagner HN: Possible enhance-

- ment of ^{67}Ga -citrate imaging by iron dextran. *J Nucl Med* 17:356-358, 1976.
- Lentle BC, Scott JR, Noujaim AA, et al: Iatrogenic alterations in radionuclide biodistributions. *Semin Nucl Med* 9:131-143, 1979.
 - Blei CL, Bom ML, Rollo FD: Gallium bone scan in myelofibrosis: case report. *J Nucl Med* 18:445-447, 1977.
 - Bekerman C, Pavel DG, Bitran J, et al: Inadvertent administration of antineoplastic agents to patients prior to Ga-67 injection: recognition of a specific radionuclide distribution pattern and its diagnostic significance. *J Nucl Med* 24:P50, 1983.
 - Bekerman C, Pavel DG, Bitran J, et al: The effects of inadvertent administration of antineoplastic agents prior to Ga-67 injection: concise communication. *J Nucl Med* 25:430-435, 1984.
 - Sephton R, Martin JJ: Modification of distribution of gallium 67 in man by administration of iron. *Br J Radiol* 53:572-575, 1980.
 - Hoffer P: Gallium: mechanisms. *J Nucl Med* 21:282-285, 1980.

Interfering drug(s): Antibiotics (e.g., clindamycin).

Nuclear medicine study affected: Tumor and abscess localization scintigraphy.

Effect on image: Localization of [^{67}Ga]gallium citrate in the bowel.

Significance: Drug-induced accumulation of [^{67}Ga]gallium citrate could mimic other causes of inflammatory bowel disease or even intraluminal [^{67}Ga]gallium citrate activity which is being eliminated from the body via the bowel. **Mechanism:** Certain antibiotics are known to cause pseudomembranous colitis, an inflammatory disease that may accumulate [^{67}Ga]gallium citrate.

Management: None; the drug responsible for inducing the colitis, however, should be discontinued and replaced with alternative therapy.

How documented: Case reports (1,2).

REFERENCES

- Pechman R, Tetelman M, Antonmattei S, et al: Diagnostic significance of persistent colonic gallium activity: scintigraphic patterns. *Radiology* 128:691-695, 1978.
- Tedesco FJ, Coleman RE, Siegel BA: Gallium citrate Ga-67 accumulation in pseudomembranous colitis. *JAMA* 235:59-60, 1976.

Interfering drug(s): Calcium gluconate; intramuscular injections.

Nuclear medicine study affected: Tumor and abscess localization scintigraphy.

Effect on image: Soft tissue accumulation of [^{67}Ga]gallium citrate.

Significance: Extravasation of intravenous calcium gluconate sometimes can result in a [^{67}Ga]gallium citrate scan that is indistinguishable from osteomyelitis unless the region of abnormal uptake can be clearly separated from bone.

In addition, a patient with unexplained radionuclide accumulation in large muscle masses should be examined to rule out local complications from intramuscular injections.

Mechanism: Pattern of radiogallium distribution caused by local complications associated with injection of drugs.

Management: None.

How documented: Case reports (1-3).

REFERENCES

- Sty JR, Starshak RJ, Hubbard AM: Ga-67 scintigraphy—calcium gluconate extravasation. *Clin Nucl Med* 7:377, 1982.
- Carter JE, Joo KG: Gallium accumulation in intramuscular injection sites. *Clin Nucl Med* 4:304, 1979.
- Bekerman C, Hoffer PB, Bitran JD, et al: Gallium-67 citrate imaging studies of the lung. *Semin Nucl Med* 10:286-301, 1980.

Interfering drug(s): Ampicillin; sulfonamides; sulfinpyrazone; ibuprofen; cephalixin and other cephalosporins; hydrochlorothiazide; methicillin, erythromycin; rifampin; pentamidine; phenylbutazone; gold salts; allopurinol; furosemide; phenazone; phenobarbital; phenytoin; phenindione.

Nuclear medicine study affected: Tumor and abscess localization scintigraphy.

Effect on image: Increased accumulation of [^{67}Ga]gallium citrate in kidneys.

Significance: Drug-induced renal radiogallium uptake could possibly be mistaken for glomerulonephritis, pyelonephritis, or the nephrotic syndrome. On the other hand, it has been suggested that [^{67}Ga]gallium citrate imaging actually may be useful in separating patients with drug-induced interstitial nephritis from those with acute tubular necrosis due to shock or trauma (1). To complicate matters, however, results of studies have shown that short-term therapy with aminoglycosides or amphotericin B, both known to be nephrotoxic agents, does not induce [^{67}Ga]gallium citrate uptake in rats (2).

Furthermore, renal [^{67}Ga]gallium citrate activity has been reported to occur relatively often even in patients with no renal disease (3), and [^{67}Ga]gallium citrate does not reliably identify cases of noninfectious interstitial nephritis (4). Therefore, the clinical significance of drug-induced [^{67}Ga]gallium citrate renal uptake is uncertain.

Mechanism: Apparently, [^{67}Ga]gallium citrate uptake in the kidney is due to acute interstitial nephritis induced by drug therapy.

Management: None; the drug responsible for inducing the nephritis, however, should be discontinued and replaced with alternative therapy.

How documented: Case reports (1, 5-9); study in rats in which a nonassociation of [^{67}Ga]gallium citrate uptake is reported with antibiotic therapy (2).

REFERENCES

- Linton AL, Clark WF, Driedger AA, et al: Acute interstitial nephritis due to drugs. *Ann Intern Med* 93:735-741, 1980.
- Taylor A, Nelson H, Vasquez M, et al: Renal gallium accumulation in rats with antibiotic-induced nephritis: clinical implications. Concise communication. *J Nucl Med* 21:646-649, 1980.
- Garcia JE, Nostrand DV, Howard WH III, et al: The spectrum of gallium-67 renal activity in patients with no evidence of renal disease. *J Nucl Med* 25:575-580, 1984.
- Graham GD, Lundy MM, Moreno AJ: Failure of gallium-67 scintigraphy to identify reliably noninfectious interstitial nephritis: concise communication. *J Nucl Med* 24:568-570, 1983.
- Kumer B, Coleman RE: Significance of delayed Ga-67 localization in the kidneys. *J Nucl Med* 17:872-875, 1976.
- Frankel RS, Richman SD, Levenson SM, et al: Renal localization of gallium-67 citrate. *Radiology* 114:393-397, 1975.
- Sherman RA, Byun KJ: Nuclear medicine in acute and chronic renal failure. *Semin Nucl Med* 12:265-279, 1982.
- Lin DS, Sanders JA, Patel BR: Delayed renal localization of Ga-67: concise communication. *J Nucl Med* 24:894-897, 1983.
- Kleinknecht D, Kanfer A, Morel-Maroger L, et al: Immunologically mediated drug-induced acute renal failure. *Contrib Nephrol* 10:42-52, 1978.

Interfering drug(s): Chemotherapeutic agents; antibiotics.

Nuclear medicine study affected: Tumor and abscess localization scintigraphy.

Effect on image: Localization of [^{67}Ga]gallium citrate in the thymus.

Significance: This pattern of distribution is of minimal clinical significance, since it has been reported to be a normal variant in children. It may, however, mimic an image similar to that observed in patients with direct tumor invasion of the thymus.

Mechanism: Depletion of thymic elements may occur, in part, as a result of therapy with chemotherapeutic agents or antibiotics. It has been theorized that following the administration of these drugs, a period of thymic recovery occurs with rapid proliferation of thymic lymphocytes and increased medullary epithelial activity. It may be during this reparative phase that [^{67}Ga]gallium citrate accumulates in the thymus.

Management: None.

How documented: Case report (1) and retrospective clinical study (2).

REFERENCES

- Spencer RP, Suresh PL, Karimeddini MK: Acquisition of thymic uptake of radiogallium in a child after therapy for infection. *Clin Nucl Med* 7:407-408, 1982.
- Donahue DM, Leonard JC, Basmajian GP, et al: Thymic gallium-67 localization in pediatric patients on chemotherapy: concise communication. *J Nucl Med* 22:1043-1048, 1981.

Interfering drug(s): High-dose heparin therapy.

Nuclear medicine study affected: Renal transplant rejection.

Effect on image: Failure to accumulate [^{67}Ga]gallium citrate in transplanted kidney during acute rejection.

Significance: [^{67}Ga]gallium citrate is rarely used in the evaluation of renal transplant rejection. If it is used, however, a normal study in a patient with acute rejection would result in a missed diagnosis of rejection and potentially severe consequences.

Mechanism: It is suggested that heparin interrupts the intravascular coagulation cycle that results in fibrin thrombosis, and may exert an anti-inflammatory effect, thus inhibiting the formation of assumed accumulation sites for ^{67}Ga in rejecting kidneys.

Management: If it is possible, interrupt heparin therapy for the imaging study.

How documented: Observations in clinical studies (1,2).

REFERENCES

- George EA, Codd JE, Newton WT, et al: Ga-67 citrate in renal allograft rejection. *Radiology* 117:731-733, 1975.
- George EA, Codd JE, Newton WT, et al: Comparative evaluation of renal transplant rejection with radioiodinated fibrinogen, ^{99m}Tc-sulfur colloid, and ⁶⁷Ga-citrate. *J Nucl Med* 17:175-180, 1976.

MISCELLANEOUS RADIOPHARMACEUTICALS USED TO ASSESS GASTRIC EMPTYING

Interfering drug(s): Atropine; propantheline; levodopa; albuterol; isoproterenol; morphine and other narcotic analgesics; Librax; TPN therapy.

Nuclear medicine study affected: Radionuclide gastric emptying studies.

Effect on image: Delayed gastric emptying.

Significance: The effect of these drugs to delay gastric emptying must be taken into consideration in the diagnostic work-up of gastroparesis.

Mechanism: Anticholinergics slow gastric emptying by inhibiting cholinergic stimulatory effects on the stomach. Dopamine is presumed to be an inhibitory neurotransmitter in the alimentary tract. The mechanism through which β -adrenergic agonists prolong gastric emptying is not clear, but it may be due to an elevation of gastric levels caused by these drugs. The gastric stasis produced by narcotic analgesics is associated with an increase in antral and duodenal smooth muscle tone resulting from the action of these drugs on cholinergic, tryptaminergic, and enkephalinergic receptors in the gastrointestinal tract. Slowing of gastric emptying while the patient is on parenteral nutrition probably is due to the increase in blood glucose induced by the intravenous nutrient load. Aluminum ion has been shown to inhibit acetylcholine-induced contractions of gastric smooth muscle.

Management: When it is clinically appropriate, discontinue therapy with interfering drugs before performing baseline radionuclide gastric emptying studies.

How documented: Clinical studies (1-11); review article (12).

REFERENCES

- Hurwitz A, Robinson RG, Herrin WF: Prolongation of gastric emptying by oral propantheline. *Clin Pharm Ther* 22:206-210, 1977.
- Nimmo J, Heading RC, Tothill P, et al: Pharmacological modification of gastric emptying: effects of propantheline and metoclopramide on paracetamol absorption. *Br Med J* 1:587-589, 1973.
- Berkowitz DM, McCallum RW: Interaction of levodopa and metoclopramide on gastric emptying. *Clin Pharm Ther* 27:414-420, 1980.
- Rees WR, Clark RA, Holdsworth CD: The effect of β -adrenoceptor agonists and antagonists on gastric emptying in man. *Br J Clin Pharmacol* 10:551-554, 1980.
- Nimmo WS, Heading RC, Wilson J, et al: Inhibition of gastric emptying and drug absorption by narcotic analgesics. *Br J Clin Pharmacol* 2:509-513, 1975.
- Prokop EK, Caride VJ, Winchenbach K, et al: The effect of metoclopramide and morphine on small intestinal transit time in normal subjects. *J Nucl Med* 24:P57, 1983.
- Frank EB, Lange R, Plankey M, et al: Effect of morphine and naloxone on gastric emptying in man. *J Nucl Med* 23:P21, 1982.
- Chaudhuri TK, Hudgins MH: Effect of Librium, Quarzan and Librax on gastric emptying time. *J Nucl Med* 23:P21, 1982.
- MacGregor IL, Wiley ZD, Lavigne ME, et al: Slowed rate of gastric emptying of solid food in man by high caloric parenteral nutrition. *Am J Surg* 138:652-654, 1979.
- Bandim P, Malmud L, Applegate G, et al: Dual radionuclide studies of gastric emptying using a physiologic meal. *J Nucl Med* 21:P66-P67, 1980.
- Hurwitz A, Robinson RG, Vats TS, et al: Effects of antacids on gastric emptying. *Gastroenterology* 71:268-273, 1976.
- Malmud LS, Fisher RS, Knight L, et al: Scintigraphic evaluation of gastric emptying. *Semin Nucl Med* 12:116-125, 1982.

MISCELLANEOUS BRAIN-IMAGING RADIOPHARMACEUTICALS

Interfering drug(s): Cancer chemotherapeutic agents; specifically reported were cyclophosphamide, doxorubicin, vincristine, actinomycin D and methotrexate.

Nuclear medicine study affected: Brain scintigraphy.

Effect on image: Patchy increased uptake of radiotracer on brain images as a result of chemotherapeutic neurotoxicity has been noted in at

least one report. Brain imaging in cases of ventriculitis and meningitis resulting from intrathecal methotrexate therapy may demonstrate ventricular and meningeal localization, respectively.

Significance: This pattern of distribution may be confused with other brain disorders.

Mechanism: Neurotoxicity of cancer chemotherapeutic drugs.

Management: None.

How documented: Case reports (1-3).

REFERENCES

- Sherkow LH: Chemotherapeutic neurotoxicity on brain scintigraphy. *Clin Nucl Med* 4:439-440, 1979.
- Conway JJ, Seibert JJ, Kuhn GP, et al: The role of radionuclides in evaluating central nervous system complications from chemotherapeutic agents. *J Nucl Med* 16:522, 1975.
- Makler PT Jr, Gutowicz MF, Kuhl DE: Methotrexate-induced ventriculitis: appearance on routine radionuclide scan and emission computed tomography. *Clin Nucl Med* 3:22-23, 1978.

Interfering drug(s): Corticosteroids (e.g., dexamethasone).

Nuclear medicine study affected: Brain scintigraphy with various radiopharmaceuticals used.

Effect on image: Diminished uptake of radiotracer into brain lesions.

Significance: Steroid therapy decreases the sensitivity of brain scintigraphy for the detection of brain neoplasms. Since steroids are used for symptomatic treatment of these lesions, it is particularly important to be aware of their pharmacologic effects on brain scans.

Mechanism: Accumulation of tracer is reduced as a result of a reduction in peritumor edema which is mediated through an improvement in capillary integrity within the cerebral tumor.

Management: Preferably perform brain scintigraphy prior to starting or following the removal of steroid medication for several days in order to avoid false negative results secondary to steroid effects. The effects of steroid therapy appear to be less profound on imaging with ^{99m}Tc-glucopate than on imaging with other brain imaging agents.

How documented: Case report (1); clinical studies (2-7).

REFERENCES

- Stebner FC: Steroid effect on the brain in a patient with cerebral metastases. *J Nucl Med* 16:320-321, 1975.
- Marty R, Cain ML: Effects of corticosteroid (dexamethasone) administration on the brain scan. *Radiology* 107:117-121, 1973.
- Waxman, AD, Beldon JR, Richli WR, et al: Steroid induced suppression of gallium uptake in tumor of the central nervous system. *J Nucl Med* 18:617, 1977.
- Waxman, AD, Beldon JR, Richli W, et al: Steroid-induced suppression of gallium uptake in tumors of the central nervous system: concise communication. *J Nucl Med* 19:480-482, 1978.
- Fletcher JW, George EA, Henry RE, et al: Brain scans, dexamethasone therapy, and brain tumors. *JAMA* 232:1261-1263, 1975.
- Crocker EF, Zimmerman RA, Phelps ME, et al: The effect of dexamethasone upon the accumulation of meglumine iohalamate and technetium pertechnetate in cerebral tumors as determined by computed tomography. *J Nucl Med* 17:528, 1976.
- Crocker EF, Zimmerman RA, Phelps ME, et al: The effect of steroids on the extravascular distribution of radiographic contrast material and technetium pertechnetate in brain tumors as determined by computed tomography. *Radiology* 119:471-474, 1976.

Interfering drug(s): Psychotropic drugs.

Nuclear medicine study affected: Cerebral radionuclide angiography.

Effect on image: Rapid accumulation of activity in the nasopharyngeal area during the arterial or capillary phase (termed the "hot nose" phenomenon).

Significance: This pattern of distribution has been noted to occur also with internal carotid arterial occlusion or increased intracranial pressure; thus, drug-induced changes in radiotracer distribution may sometimes be mistaken for disease.

Mechanism: Psychotropic drugs cause the hot nose phenomenon by increasing blood flow in the external carotid circulation.

Management: Confirm diagnosis with other diagnostic modalities.

How documented: Retrospective clinical study (1).

REFERENCE

- Watts G, Mena J, Joe SH: Cerebral radioisotope angiogram: the significance of increased external carotid circulation. *J Nucl Med* 17:527, 1976.

MISCELLANEOUS RADIOPHARMACEUTICALS USED TO ASSESS RENAL FUNCTION

Interfering drug(s): Iodinated contrast agents; aminoglycosides (e.g., gentamicin, tobramycin).

Nuclear medicine study affected: Radionuclide renal function studies (^{123}I or ^{131}I iodohippurate; ^{125}I iothalamate).

Effect on image: Reduction in effective renal plasma flow (ERPF) values. The degree of reduction depends on the degree of preexisting renal disease, the amount of contrast material administered, and the route of administration. Aminoglycosides may also cause a decreased glomerular filtration rate.

Significance: Renograms performed immediately following arteriography or contrast-enhanced CT scans should not be used as baseline studies for comparison with future examinations. Aminoglycoside-induced decrease in glomerular filtration rate may interfere with the differential diagnosis of renal dysfunction.

Mechanism: Direct effect of contrast agents on renal function; aminoglycoside nephrotoxicity. **Management:** The effect of the contrast material usually persists no longer than 2 weeks, at which time there is a return to baseline renal function; therefore, if baseline radionuclide study is needed, it should be performed 1–2 weeks following any study in which iodinated contrast material is used.

A baseline glomerular filtration rate study should be obtained prior to initiation of aminoglycoside therapy, when clinically appropriate.

How documented: Clinical studies (1,2).

REFERENCES

1. Gates GF, Green GS: Transient reduction in renal function following arteriography and contrast enhanced CT scanning. Scientific exhibit presented at the 28th Annual Meeting of the Society of Nuclear Medicine, Las Vegas, June 1981.
2. Keys TF, Kurtz SB, Jones JD, et al: Renal toxicity during therapy with gentamicin or tobramycin. *Mayo Clin Proc* 56:556–559, 1981.

Interfering drug(s): Cyclosporine; cisplatin. **Nuclear medicine study affected:** Renal function scintigraphy (^{123}I or ^{131}I iodohippurate

and $^{99\text{m}}\text{Tc}$ -DTPA for renal graft evaluation).

Effect on image: With cyclosporine, there typically is good perfusion of transplanted kidney with $^{99\text{m}}\text{Tc}$ -DTPA but reduced renal tubular function with ^{123}I or ^{131}I iodohippurate. Cisplatin is reported to decrease urinary excretion.

Significance: The pattern of distribution observed in patients on cyclosporine therapy mimics that observed in patients with acute tubular necrosis (ATN); therefore, the differentiation of ischemic ATN from cyclosporine nephrotoxicity often is difficult in renal transplant recipients treated with cyclosporine. Similarly, cisplatin may interfere in the differential diagnosis of renal tubular dysfunction.

Mechanism: Nephrotoxic effects of cyclosporine may become apparent early in the post-operative course as acute renal failure or, later, as a gradual decrease in glomerular filtration rate; these nephrotoxic effects alter scintigraphy as described above.

Nephrotoxicity, which is dose related and can be severe, may occur in patients receiving cisplatin and is associated with renal tubular damage.

Management: Nephrotoxicity usually is reversible on discontinuation or dosage reduction of cyclosporine. Clinical findings, timing with respect to transplantation, patient history, etc. must be closely correlated with radionuclide study results in order to help make a distinction between ATN and drug-induced disease. In addition, hyperbilirubinemia invariably is a sign of high blood cyclosporine levels and, thus, is a reasonable indicator of nephrotoxicity in light of worsening graft function. Graft biopsy may be useful in distinguishing drug toxicity from other transplant complications.

How documented: Clinical studies in small numbers of renal and liver transplant patients (1,2); study in rats (3).

REFERENCES

1. Kim EE, Gutierrez C, Sandler CM, et al: Radionuclide detection of cyclosporin A nephrotoxicity in renal transplant patients. *J Nucl Med* 24:P129, 1983.
2. Klintmalm GBG, Klingensmith WC III, Iwatsuki S, et al: $^{99\text{m}}\text{Tc}$ DTPA and I-131 hippuran findings in cyclosporin A nephrotoxicity in liver transplant recipients. *J Nucl Med* 22:P37–P38, 1981.

3. McAfee JG, Subramanian G, Schneider RF, et al: Technetium-99m DADS complexes as renal function and imaging agents: II. Biologic comparison with I-131 hippuran. *J Nucl Med* 26:275–286, 1985.

Interfering drug(s): Furosemide.

Nuclear medicine study affected: Renal function scintigraphy (^{123}I or ^{131}I iodohippurate and $^{99\text{m}}\text{Tc}$ pertechnetate for renal graft evaluation).

Effect on image: Relatively large increases in dosage of furosemide can improve renal function to the extent that misleadingly good renogram and flow curves are obtained, resulting in false negative studies; relatively large decreases in dosage may have the opposite effect, resulting in flow patterns suggesting slight graft deterioration.

Significance: It is important to account for the effects of furosemide on renal function studies, since it is a commonly used diuretic in the management of patients who have undergone renal transplantation.

Mechanism: Furosemide increases renal blood flow by reducing renal vascular resistance through vascular dilation resulting from stimulation of the prostaglandin system.

Management: Avoid large changes in furosemide dosage within 24 hours of performing radionuclide renal function studies.

How documented: Retrospective clinical study (1).

REFERENCE

1. Clorius JH, Dreikorn K, Zelt J, et al: Renal graft evaluation with pertechnetate and I-131 hippuran. A comparative clinical study. *J Nucl Med* 20:1029–1037, 1979.

Interfering drug(s): Probenecid.

Nuclear medicine study affected: Renal function scintigraphy (^{123}I or ^{131}I iodohippurate, $^{99\text{m}}\text{Tc}$ -glucopeptate).

Effect on image: Decreased renal accumulation and excretion.

Significance: May give the false impression of renal tubular dysfunction.

Mechanism: Probenecid is an inhibitor of renal tubular transport mechanism for organic acids.

Management: Discontinue probenecid prior to study.

How documented: Rat study (1), rabbit study (2), mouse study (3).

REFERENCES

1. Lee HB, Blaufox MD: $^{99\text{m}}\text{Tc}$ glucoheptonate (GHA) renal uptake: influence of biochemical and physiologic factors. *J Nucl Med* 25:P75–P76, 1984.
2. Antar MA, Jones AN: Effect of probenecid on renal extraction of three renal radiopharmaceuticals at 15 and 30 minutes. *J Nucl Med* 26:P131, 1985.
3. Fritzberg AR, Whitney WP, Kuini CC, et al: Bio-distribution and renal excretion of $^{99\text{m}}\text{Tc}$ N, N'-bis(mercaptoacetamido)ethylenediamine. Effect of renal tubular transport inhibitors. *Int J Nucl Med Biol* 9:79–82, 1982.

15

Iatrogenic Alterations in the Biodistribution of Radiotracers as a Result of Radiation Therapy, Surgery, and Other Invasive Medical Procedures

Brian C. Lentle and Colin B. Styles

In this chapter, we describe those changes in radiopharmaceutical biodistributions which result from physical insults to the body. It would be gratuitous to refer, for example, to the lack of uptake of radiocolloid by the spleen after splenectomy, however. Thus it is only those effects which are unexpected or incidental that will be described.

Much of the experience that is being accumulated in this context is, of necessity, anecdotal and the subject only of case reports. From the number and diversity of reports, however, the clinician should be alerted to the potential for scan findings to reflect not only the disease but also his or her investigation and treatment.

Although chemicals often are potent modifiers of the biological distributions of radiotracers (1, 2), changes in such distributions can result from a variety of other causes. An understanding of these causes is essential before diagnostic inferences can be made from a scintigraph. Moreover, the observations documented in this chapter reemphasize the importance of understanding the whole patient rather than of approaching a scintigraph as an existential exercise in detecting disease.

No description of our understanding of the effects of physical insults on radiopharmaceutical biodistributions is, however, likely to remain exhaustive for long.

THERAPEUTIC IRRADIATION

The changes occurring in an organ following therapeutic irradiation can be summarized as follows:

1. Cell death and damage
2. An acute inflammatory response
3. Late vascular changes with obliteration of the vascular bed
4. Healing, including fibrosis and cell death

These effects are dependent on radiation dose and fractionation, type of radiation, volume of tissue irradiated, mitotic activity of cells exposed, and degree of specialization of cells (3). All of these variables influence the impact of such irradiation on radionuclide scintigraphy. This impact may be demonstrated in differing ways with different radiopharmaceuticals. It may be important not only in the avoidance of erroneous scan interpretations but also in the assessment of organ damage by radiation.

The effects of radiation, being complex, cannot always be readily predicted. Thus, in this review the effects on each organ are considered separately.

Heart

Uptake of ^{99m}Tc -pyrophosphate has been observed in the hearts of a group of patients without obvious cardiac disease who had received

left chest wall irradiation in a dose of 1800–5000 rad on the average of 32 months earlier. Such uptake was attributed to the myocardium, pericardium, or both (4).

Lungs

Korsower et al. (5) studied the effects of 3000 rad applied to the hemithoraces of a group of rabbits. Two hours following irradiation, 52% of the experimental group had a moderate decrease in pulmonary perfusion as studied with ^{131}I -labeled macroaggregated albumin (MAA). After 24 hours, pulmonary perfusion became normal, but 2 months later the animals demonstrated abnormal lung perfusion. The early changes were attributed to either edema or vasospasm, whereas the late changes were attributed to vascular occlusion and fibrosis.

Bateman and Croft (6) have reported on the effects of 3000–3400 rad on the human lung as observed with ^{133}Xe gas ventilation and ^{99m}Tc -MAA perfusion scans. The patients had been irradiated between 6 months and 12 years previously. Ventilation to perfusion mismatches in patients not believed to have had pulmonary thromboembolism were attributed to irradiation. Sarreck et al. (7) reported on a patient with histologically confirmed radiation pneumonitis (6000 rad 1 year earlier) who demonstrated absent perfusion on a ^{99m}Tc -MAA perfusion lung scan of the irradiated area. Increased activity in this area was also noted on a ^{99m}Tc -pyrophosphate bone scan, an observation we also made (1). A probable explanation for these changes may be the late vascular changes induced by radiation while the airways remain patent. The uptake of ^{99m}Tc -pyrophosphate is less readily explained.

Freeman et al. (8) studied the uptake of [^{67}Ga]gallium citrate in irradiated lungs to determine whether this tracer might contribute to the diagnosis of radiation pneumonitis. Although uptake of radiogallium in the lungs of some of their 12 patients was noted, there was no overall consistent correlation between the clinical and radiographic manifestations of radiation pneumonitis and the gallium scan. Siemsen et al. (9) have also observed occasional uptake of radiogallium in irradiated lung.

Liver

In reviewing the evaluation of liver and spleen injury with radionuclides, Usseiman (10) and Gilday and Alderson (11) have described the geometric defects in colloid liver images due to irradiation in amounts in excess of 3500 rad. This finding is so characteristic as to allow a "spot diagnosis" and was described as early as 1965 (12). The same authors noted that liver recovery may occur following as much as 5500 rad. Radiation has been reported to have a more marked effect on the liver Kupffer cells, as imaged with radiocolloids, than on the hepatocytes, as imaged with ^{99m}Tc -iminodiacetic acid (IDA) analogs or ^{67}Ga -citrate* (13). The changing pattern of uptake of liver imaging radiopharmaceuticals has been described by Herbst et al. (14). The hepatocytes, being more acutely radiosensitive, may show deficient function earlier after irradiation, while the Kupffer cell effects have a different temporal evolution.

This dissociation between the Kupffer cell and the hepatocyte may also be noted in imaging with ^{99m}Tc -labeled sulfur colloid and ^{67}Ga -citrate (Fig. 15.1, A and B). Otherwise, the various patterns detected by colloid scintigraphy that follow irradiation of the liver have been reported in several publications but tend to be predictable if the radiation beam dimensions are known (15–17).

Kidneys

Radiation in amounts in excess of 3000 rad in typical treatment schedules has been found to cause an increase in the renal uptake of both ^{99m}Tc -labeled pyrophosphate and methylene diphosphonate (MDP) (18, 19). In one of the reports, this increased uptake, found between 5 and 6 months after renal irradiation, did not persist at 10 months after treatment and was presumed to reflect radiation-induced renal tubular damage (18).

Bone

The effects of radiation on the distribution of bone-seeking radiopharmaceuticals has been

* Although [^{67}Ga]gallium citrate is preferred by IUPAC, ^{67}Ga -citrate is standard, and both are used throughout this chapter.

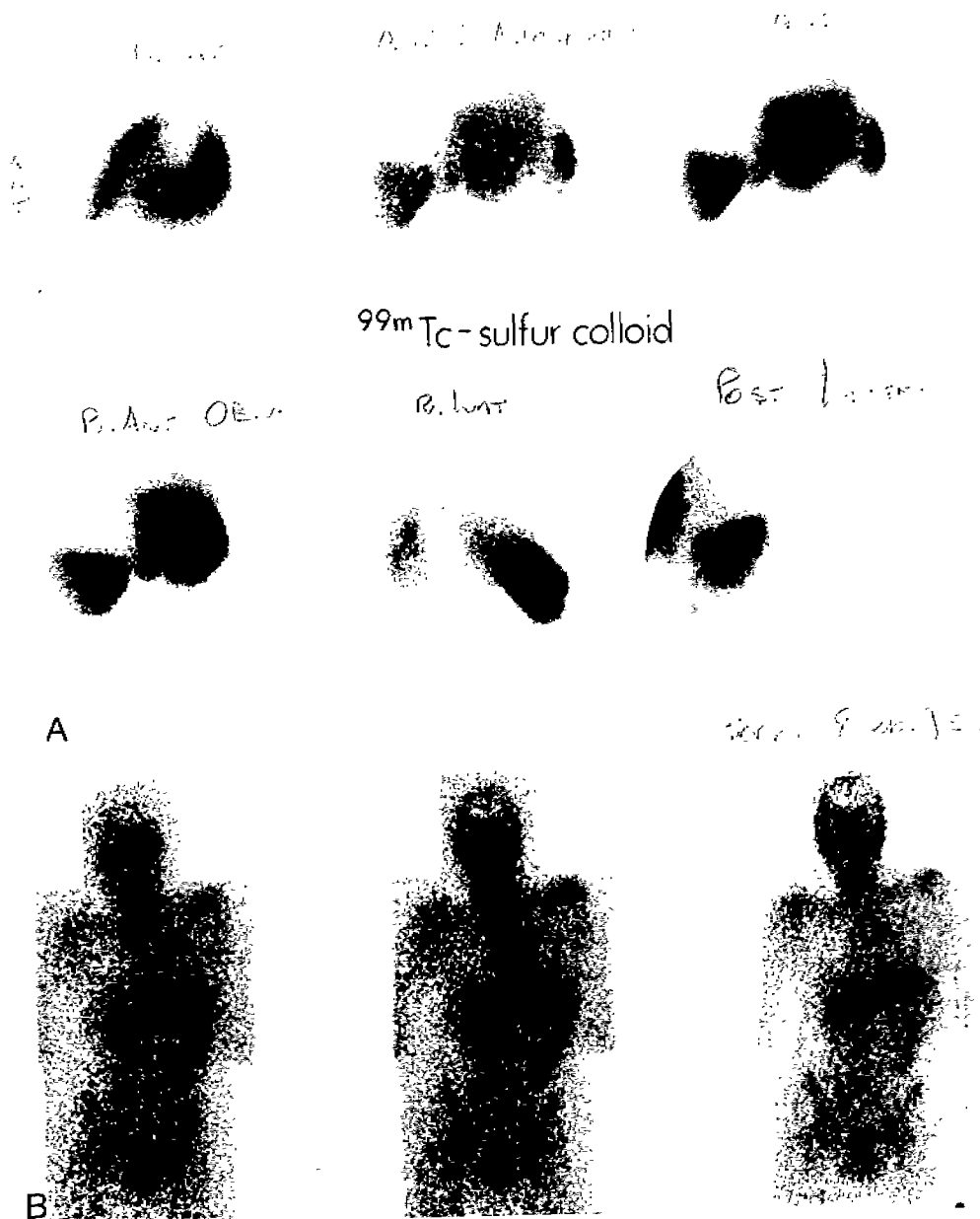

Figure 15.1. A. A ^{99m}Tc -labeled sulfur colloid liver and spleen scan shows a defect in the right lobe of liver with a sharp linear margin, which results from therapeutic irradiation applied to the right lower hemithorax. B. A ^{67}Ga -citrate scan of the same patient 48 hours later. Not only is there defective uptake of radiogallium by the liver, but also blood background activity is high and the tumor is not evident.

studied in rabbits (20–22). In controlled experiments, the effects of a single dose of 756 rad were compared with the effects of a fractionated dose of 4650 rad given over 3 weeks. In both groups of rabbits, within the first 24 hours, there was an increase in blood volume in the bone marrow as measured with ^{51}Cr -labeled rabbit red blood cells. Histologically, this correlated with marrow sinusoidal dilation. The bone marrow blood volume decreased below normal 1 month after irradiation and decreased even more 12 months after irradiation. In the longer term, tibial cortical and epiphyseal blood volumes fell below normal. Bone blood flow measured by an injection of $^{86}\text{RbCl}$ 1 minute before the animal was killed showed progressive falls in blood flow to both bone marrow and cortical bone which were not obvious 1 month after irradiation.

Bone remodeling was studied by tetracycline labeling. Maximal remodeling was evident 3 months after irradiation and persisted up to 12 months, at which time vascular patency was reduced.

These findings were related to bone imaging with ^{99m}Tc -pyrophosphate in irradiated animals. Both early images and images obtained 3 hours after injection of the radiotracer were obtained. Three phases of bone response to irradiation were identified:

1. Up to 1 month after irradiation, increased tracer concentration was noted in the images of bone, particularly in the early images where it was presumed to largely reflect increased bone vascularity and altered capillary permeability.
2. Between 3 and 6 months after irradiation, the early images were found to be normal or to show reduced activity. Delayed images demonstrated increased tracer concentrations believed to represent increased bone remodeling, a concept supported by autoradiographic data obtained with ^{99m}Tc -pyrophosphate. This phase was accompanied by increased soft-tissue activity in some animals.
3. Six to 12 months after irradiation, delayed images showed decreased bone tracer uptake corresponding to radiation-induced vascular

changes. Radiation changes were found to be more marked in trabecular bone than in cortical bone.

Lund and Nathanson (22) found new bone formation in rabbit mandibles irradiated with 2000 rad but not in mandibles irradiated with 1000 rad in a single exposure. Abnormalities in such bone were not detected, however, on gamma camera images obtained with ^{99m}Tc -MDP.

Clinical observations usually identify this third phase of clearly demarcated, decreased uptake of ^{99m}Tc -labeled phosphates (1, 23). Clinical studies have shown a reduction in the uptake of ^{99m}Tc -pyrophosphate in normal bone irradiated with 2000–5400 rad between 6 months and 7 years before imaging (24). In this report, Cox also identified the uncertainty that results from a decrease in uptake at a site of tumor that is irradiated. It is not clear whether, for any given patient, this represents tumor response or merely the suppression of uptake of the radiotracer.

Further case reports (25, 26) have noted not only the suppressed uptake of ^{99m}Tc -labeled phosphates in irradiated bone but also the increased uptake of those tracers in adjacent soft tissues.

At the Cross Cancer Institute in Edmonton, Alberta, Canada, we, like Cox (24), have noted a “flare” of activity on bone scans after the palliative irradiation of bone metastases. The increased activity of the “flare,” comparable with that observed following chemotherapy (27), usually decreases to less than normal at about 6 months after treatment (Fig. 15.2).

We frequently see, although we are not aware that it has been reported elsewhere, suppressed uptake of ^{67}Ga -citrate in irradiated bone which is consistent with decreased uptake of ^{99m}Tc -MDP when both investigations are carried out. This finding merely reflects the known distribution of ^{67}Ga -citrate into bone and bone marrow (28) and is consistent with other observations made earlier.

Bone Marrow

Nelp et al. (29) have studied irradiated bone marrow in the lower limbs of rabbits by using

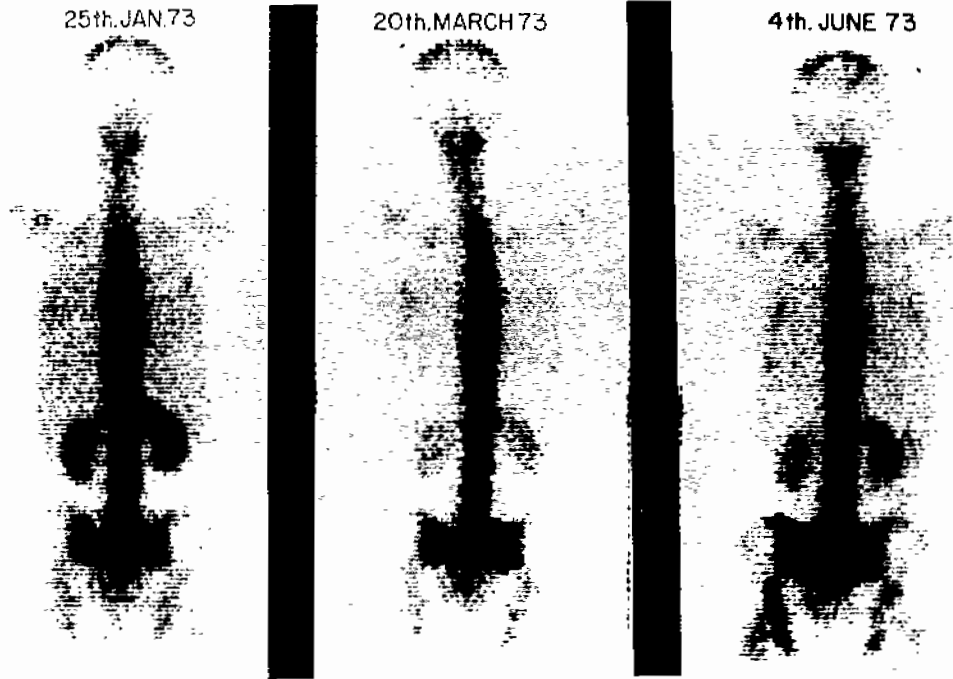

Figure 15.2. Sequential scans (^{99m}Tc -labeled polyphosphate) in a patient with metastatic breast cancer. The first scan reveals the initial evidence of metastatic disease in the atlas, confirmed radiographically. After local palliative irradiation, the lesion first shows increased uptake of the tracer and then shows less marked uptake, although by the time of this last scan in June 1973 the patient had demonstrated evidence of disseminated metastatic disease.

one limb as a control and both ^{99m}Tc -labeled sulfur colloid and $^{59}\text{FeCl}_2$ to evaluate differing marrow components. A fractionated dose of 200–5000 rad was administered. With doses in excess of 1000 rad, there was an acute drop in erythropoietic activity, with maximal drop occurring 7 days after irradiation and with partial recovery occurring in 2 weeks. This finding was not paralleled by the reticuloendothelial (RE) component of bone marrow activity, a dissociation similar to that described previously for the liver. The RE activity decreased more slowly after 2 weeks, to parallel that of the erythropoietic cells. Thereafter, the extraction efficiency of both cell lines continued to fall for 2 months, and then, depending on dose, varying degrees of return to normalcy were observed. It may be that recovery is due to stem cell repopulation of erythropoietic marrow in irradiated marrow.

Clinically, Knospe et al. (30) studied the distribution of ^{52}Fe -transferrin in patients having

received between 4000 and 4400 rad to varying fields in the treatment of lymphoma. Some degree of marrow expansion, depending on the volume of bone marrow irradiated, was noted 3 months after treatment. Suppression of irradiated marrow activity, with incomplete recovery 1 year after such irradiation, was evident; such recovery does occur, however (31).

Rubin and Scarantino (32) have reviewed the subject of radiation-induced bone marrow damage and reported on their experience. In patients with lymphoma treated with between 4000 and 4500 rad, the RE marrow activity examined with ^{99m}Tc -labeled sulfur colloid did not recover in the 6–12 months after treatment. Thereafter, there was a gradual return to approximately 66% of normal activity after 2 or 3 years and to 75% of normal activity after 4 or 5 years. Bone marrow expansion took 1 year to develop after treatment. In other experiments, Rubin and Scarantino (32) found some evidence



Figure 15.3. A [^{111}In]indium chloride bone marrow scan, posterior view, in a patient who received axillary and mediastinal irradiation in the treatment of left breast cancer. The sharply demarcated defective uptake of the tracer in irradiated parts is clearly evident.

to suggest that marrow repopulation derives from locally situated undifferentiated mesenchymal cells.

In a study of a small number of children, Siddiqui et al. (33) found recovery of marrow RE activity (as detected with ^{99m}Tc -labeled sul-

fur colloid) 6 months after irradiation of bone marrow with 3000 rad.

Bell et al. (34) found that in patients with testicular tumors, doses of 3000 rad in 3 weeks caused a decrease in the skeletal uptake of both ^{18}F and ^{99m}Tc -labeled sulfur colloid, without there being radiographic abnormalities in the bone. The depression of activity in the RE system tended to be more persistent than that in bone. Thus marrow imaging does have limited application in evaluating hematopoiesis after radiation treatment (35).

Although it has not been systematically investigated, we have noted the expected changes from therapeutic irradiation in bone marrow images obtained with [^{111}In]indium chloride (Fig. 15.3, A and B).

Thyroid Gland

Scintigraphic abnormalities of the thyroid after irradiation of the gland have been reported (36) but are due to nonpalpable nodules and merely reflect the known incidence of radiation-associated nodular thyroid disease.

Salivary Glands

The clinical manifestations of radiation sialadenitis, namely tenderness progressing to a dry mouth, are well known. Salivary glands that have been irradiated show an often-intense uptake of ^{67}Ga -citrate (37, 38); this finding may persist for at least 3 years (39).

In our experience, salivary glands subjected either to external beam irradiation or to sodium [^{131}I]iodide given in doses intended to be therapeutic for thyroid cancer will show impaired uptake of [^{99m}Tc]pertechnetate.

Gallium Biodistribution and Tumor Imaging

The effects of whole-body irradiation on the biodistribution and excretion of ^{67}Ga -citrate have been studied in rats and mice (40–42). Fletcher et al. (40) irradiated rats with a whole-body dose of 720 rad before giving injections of ^{67}Ga -citrate. They noted reduced whole-body retention of the radiotracer but increased uptake in the bone in these rats compared with a control group of animals. It was suggested that irradiation interfered with the binding of ^{67}Ga to trans-

port plasma proteins. Similar experiments were carried out by Bradley et al. (41) on rats with Walker-256 cervicocarcomas. In addition to the findings noted previously, they observed that therapeutic irradiation reduced the tumor uptake of radiogallium. Bradley et al. also reported on evidence that they thought might be explained by the saturation of transferrin with iron available as a result of marrow suppression by radiation. Interestingly, Sephton et al. (43, 44) have found that the detectability of tumors by gallium is enhanced by the intramuscular injection of iron 3 hours following the intravenous injection of ^{67}Ga -citrate.

Results of clinical studies have complemented these observations by demonstrating the limitations of the use of ^{67}Ga -citrate in determining the response of tumors to therapeutic irradiation (45, 46). Kondo et al. (46) have found that irradiation of esophageal tumors with more than 2000 rad significantly reduced the uptake of radiogallium.

In animal experiments, similar results have been reported for $^{203}\text{HgCl}_2$ with both radiation and cyclophosphamide (47), although this tumor-seeking radiotracer has not come into general use because of the radiation dose to the kidneys (48).

Spleen

Both therapeutic irradiation of the spleen for Hodgkin's disease (49) and irradiation from Thorotrast administered long before has resulted in functional hyposplenism or asplenia as diagnosed by imaging with $^{99\text{m}}\text{Tc}$ -labeled sulfur colloid (50–53).

Lymph Nodes

In keeping with the effects of irradiation on RE cell activity documented previously, Eng et al. (54) have found that radiation compromises the uptake of $^{99\text{m}}\text{Tc}$ -labeled antimony sulfur colloid by lymph nodes.

Gastrointestinal Tract

Irradiation, when combined with chemotherapeutic drugs, in particular with adriamycin, has been reported to cause an esophagitis (55). Indeed, other mucosal surfaces may respond similarly, and this polymucositis has been re-

ported as a cause of ^{67}Ga uptake and hence "false positive" images in tumor diagnosis (56).

IATROGENIC TRAUMA

Biopsy and Open Surgery

It is well recognized that surgical incisions, before they are healed, cause a local uptake of a variety of tracers such as $^{99\text{m}}\text{Tc}$ -labeled phosphates and ^{67}Ga -citrate, which presumably reflects the local increase in the extravascular extracellular space as well as increased blood supply (1, 57–59). Silberstein et al. (60) have shown that in postlaminectomy patients, changes in radiotracer uptake due to surgical trauma occur less frequently with $^{99\text{m}}\text{Tc}$ -diphosphonate than with ^{67}Ga -citrate.

Relatively trivial insults such as biopsy and injection sites may also cause recognizable changes on a scan made with such agents (61–63) (Fig. 15.4). The localization of $^{99\text{m}}\text{Tc}$ -MDP at, for example, sites of injection of iron dextran (64, 65) may occur for some time following the injection and may involve a local chemical reaction between the injectate and the radiopharmaceutical, as described by Van Antwerp et al. (64). Extravasated calcium gluconate from attempted intravenous injection is associated with soft-tissue localization of ^{67}Ga -citrate (66).

Nevertheless, in a prospective study Tyler and Powers (67) did not find evidence, on subsequent bone scans made with $^{99\text{m}}\text{Tc}$ -hydroxymethylene diphosphonate, of reaction to bone marrow biopsies performed with Jam Shidi 11-gauge needles. Similarly, Alazraki et al. (68) have suggested, through extrapolation from animal data, that needling or drilling metaphyseal regions in children probably will not affect the results of later bone scans. This information may be of particular importance in the clinical setting where an abnormal bone scan performed following needle aspiration to help in the diagnosis of osteomyelitis may be (falsely) assumed to be the result of aspiration trauma.

Abnormal findings in the skull on both brain (with [$^{99\text{m}}\text{Tc}$]pertechnetate or $^{99\text{m}}\text{Tc}$ -labeled chelates) and bone scans will be found long after a craniotomy (69).

Delayed Consequences of Surgery and Prostheses

The effects of surgery are not limited to those related to local tissue damage only. Eikman et al. (70) have reported ^{67}Ga -citrate uptake in the stomach of patients with postoperative gastritis, and we have suspected a similar explanation for the same finding in patients with nausea and vomiting following chemotherapy.

Foreign substances introduced into the body at surgery may predictably cause local inflammation and, apart from the use of radionuclides to diagnose the complications of such prostheses as those which replace joints, have been found to cause uptake of both phosphate derivatives and ^{67}Ga -citrate (71–76). Thus radiogallium has been found to localize in tissues involved with starch-peritonitis (71, 72) as well

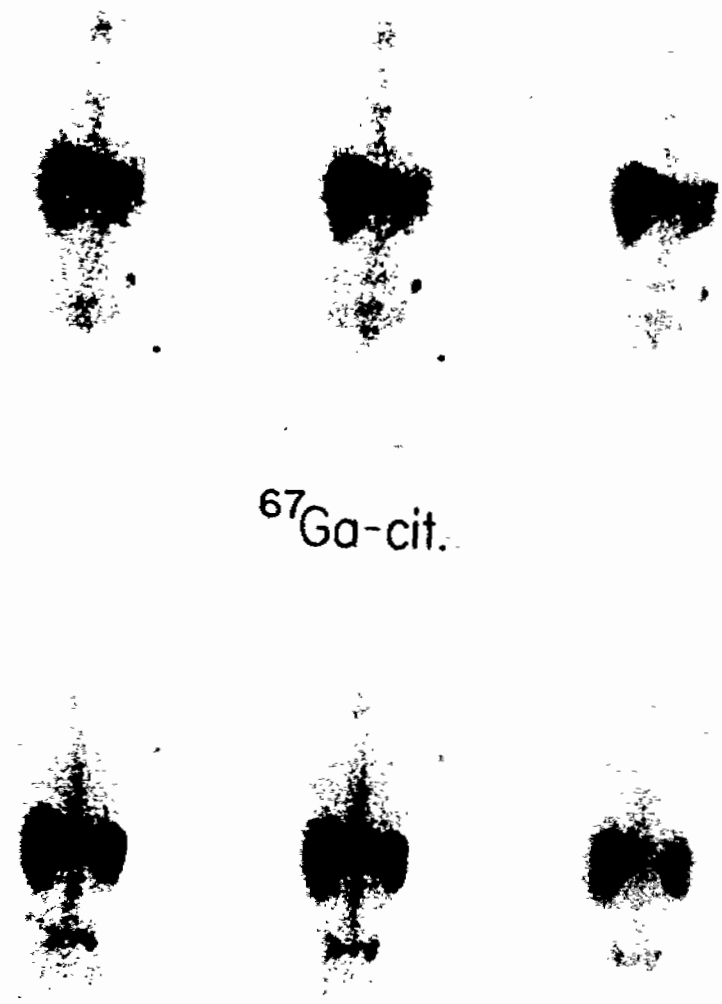

Figure 15.4. A ^{67}Ga -citrate scan obtained 48 hours after injection of the radiotracer. The patient had a splenic abscess diagnosed by this technique and accounting for the intense activity in the left upper abdominal quadrant. Note, however, the smaller foci of increased uptake in the left iliac crest at a biopsy site and in the left deltoid at a site of uncomplicated injection of the pain-relieving drug "Talwin."

as in a capsular contracture around a breast implant. Presumably such findings reflect no more than a chronic low-grade inflammatory response (73). ^{99m}Tc -pyrophosphate and its analogs have been found adjacent to both breast and cardiac valve prostheses (74, 75) as well as a paraffin pack used in relation to a thoracoplasty

(76). Such reports will almost certainly proliferate.

The effects of surgery need not always be proximate to the surgical site. We have noted that retroperitoneal dissections may result in a surgical sympathectomy, with resultant increased uptake of radiotracer in the bones of the

affected limb (77). The finding is not different from those due to sympathetic denervation of whatever origin (78). Ege (79) has described how surgery may impair lymph node visualization in the corresponding draining lymph nodes, presumably by blockade with surgical debris.

analogous labeled with ^{99m}Tc in the myocardium (82).

External Cardiac Massage

Rib trauma commonly accompanies this procedure such that the fortunate survivor, if then subjected to a bone scan, demonstrates findings that are obviously iatrogenic although a small price to pay for survival (Fig. 15.6).

Intubation

Tissues subjected to trauma by the passage of a nasogastric tube have been found to show increased uptake of a ^{99m}Tc -labeled phosphate derivative (83).

Cardioversion

Defibrillation has been found to result in increased uptake of bone imaging agents in the tissues of the chest wall at the site of application of the electrode (80, 81) (Fig. 15.5), and direct current transthoracic countershock has likewise been reported to cause localization of phosphate

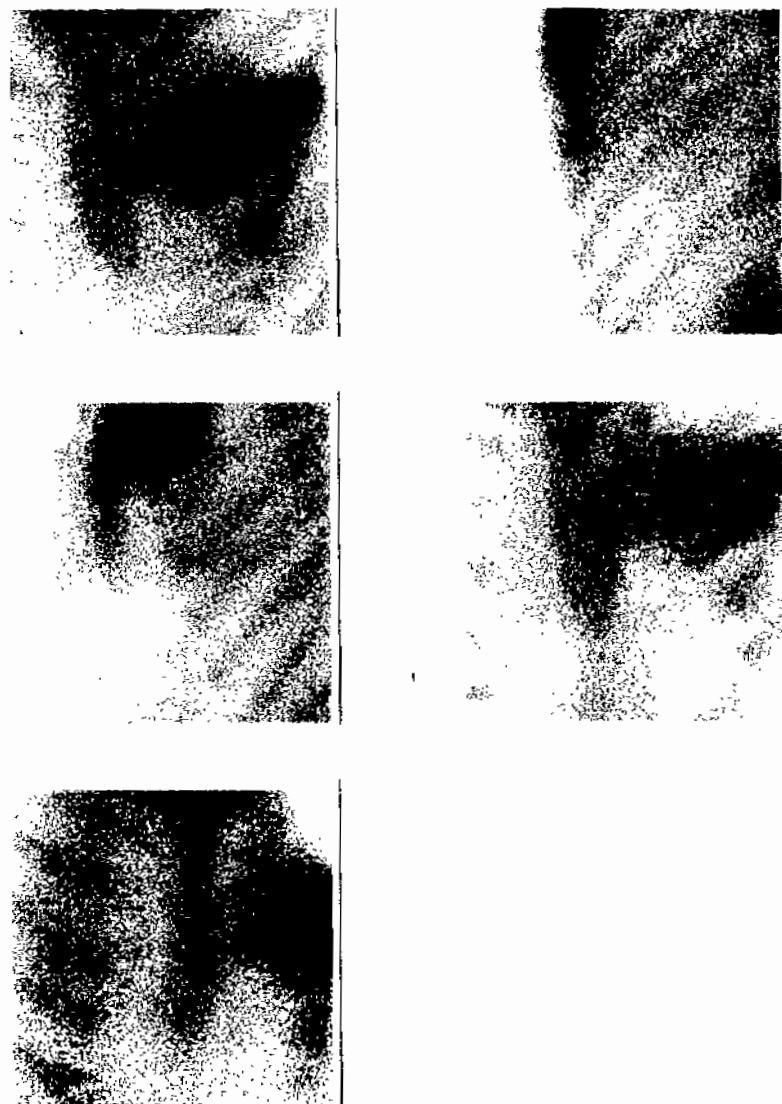

Figure 15.5. A ^{99m}Tc -pyrophosphate scan of the thorax in a patient who had been subjected to cardiac defibrillation. The superficial and, hence, noncardiac localization of the abnormal uptake is clearly evident in the tangential view (*top right*). The uptake was in a defibrillation burn.

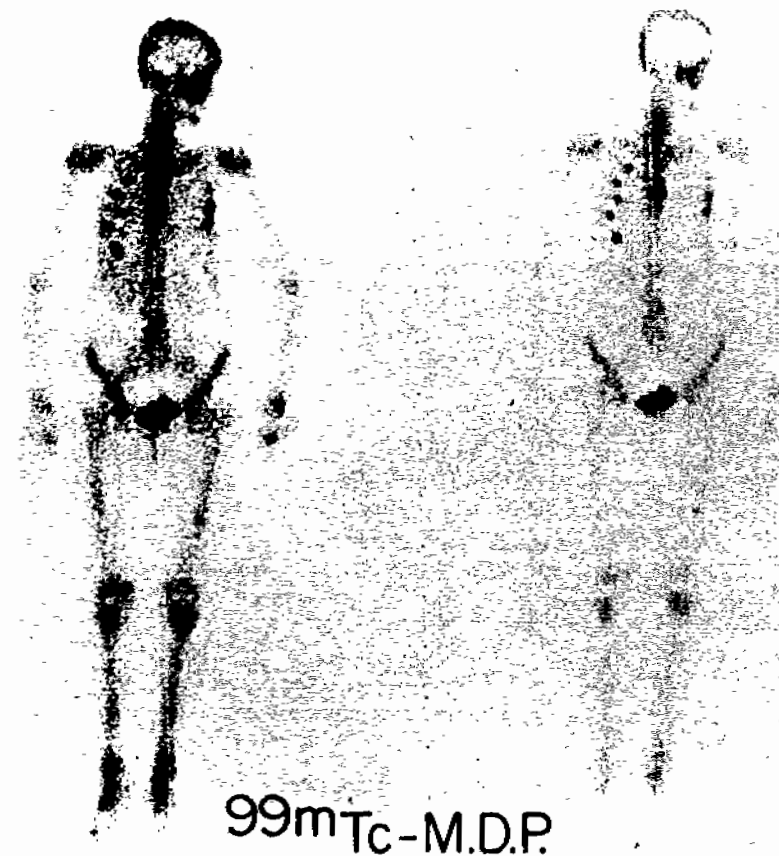

Figure 15.6. A ^{99m}Tc -MDP bone scan in a patient who had received cardiac massage after an arrest. The uptake at bilateral anterior rib and sternal fractures, although these were not initially detected radiographically, is typical of this form of iatrogenic trauma.

BLOOD TRANSFUSION

Blood transfusion, inasmuch as it may cause iron overload, has been found to influence the stability of ^{99m}Tc -MDP and, to a lesser extent, ^{99m}Tc -pyrophosphate. The result is poor bone visualization and marked renal uptake of the ^{99m}Tc , which possibly reflects the formation of such a chelate as ^{99m}Tc -labeled iron ascorbate (84).

CHEMOPERFUSION

Chemoperfusion has been observed to cause marked uptake of a bone scanning agent in the perfused limb (85).

IMMUNOTHERAPY

Immunotherapy has been employed in the treatment of cancers. We have noted that patients treated with *Bacillus Calmette-Guérin* (BCG) may develop a systemic granulomatosis (86). In both patients and experimental animals, this granulomatosis is associated with changes in the biodistribution of radiogallium that are particularly evident as abnormal lung uptake of that tracer (87, 88). Local sites of injection of an immune stimulant such as *Corynebacterium parvum* have also been reported to result in uptake of radiogallium (63).

RENAL DIALYSIS

On the basis of a series of images made with ^{67}Ga -citrate in patients on renal dialysis and showing little liver uptake and marked uptake in bone, we had suspected that dialysis might interfere with the biodistribution of radiogallium (1). Detailed studies have not confirmed this (89, 90), and the finding may have related to renal bone disease.

Transient abnormalities found on the brain scans of patients on dialysis have been reported (91).

DeGraaf et al. (92), in a study made to determine the sensitivity of ^{99m}Tc -hydroxyethylidene diphosphonate (HEDP) in detecting gastric calcification complicating chronic renal failure, found that the radiochemical interacted with saline and the dialysate fluid to form free pertechnetate. This resulted in the predictable uptake of the pertechnetate by stomach, thyroid, and salivary glands (92).

INADVERTENTLY ALTERED ROUTES OF ADMINISTRATION OF RADIOPHARMACEUTICALS

Occasionally, a radiotracer is injected intraarterially which may result in an abnormal scintigraph (1, 93). The nature of the abnormality will be influenced by the physical form of the tracer; e.g., ^{99m}Tc -MAA will be virtually entirely extracted in the periphery, whereas ^{99m}Tc -labeled phosphates merely show unusual concentrations in tissues to which they are delivered in high concentrations.

An interstitial injection has recently been reported (94) to result in lymph node visualization presumably due to a volume effect, as the tracer (^{99m}Tc -MDP) was not one that might have been expected to be extracted by the cells in such a node.

Radiotracers that are rapidly or effectively extracted are more prone to provide bizarre radiotracer biodistributions. An example resulting from the injection of ^{99m}Tc -MAA into a pulmonary artery catheter has been reported (95).

A trivial example but one with considerable practical implications is the development of a cerebrospinal fluid leak after lumbar puncture which can both result from and be imaged by tracer studies (96). This leak can result in chronic and distressing headaches (97) and is readily treated by a "blood patch" (98).

CONCLUSION

A variety of iatrogenic physical and other insults causing changes identifiable on radionuclide images are described. The nature of these abnormalities and the profusion of isolated reports concerning them may, at first, be intimidating. Most, if not all, of these abnormalities, however, might be anticipated from an understanding of disease processes, from a knowledge of the particular patient, and from insight into the mechanisms of radiopharmaceutical localization. Therefore, this review merely emphasizes the importance of understanding radionuclide scans as an aspect of patient care and not as abstract exercises divorced from the human beings with whom we work.

ACKNOWLEDGMENTS

We are indebted to Dr. P. G. Heslip of the University of Alberta Hospital, Edmonton, for

Figure 15.5, to Mr. Karl Liesner for preparing the illustrations, and to Mrs. M. Laschowski and Mrs. E. Dolina for typing the manuscript.

REFERENCES

- Lentle BC, Scott JR, Noujaim AA, et al: Iatrogenic alterations in radionuclide biodistributions. *Semin Nucl Med* 9:131-143, 1979.
- Hladik WB III, Nigg KK, Rhodes BA: Drug-induced changes in the biologic distribution of radiopharmaceuticals. *Semin Nucl Med* 12:184-218, 1982.
- Robbins SL, Cotran RS: *Pathologic Basis of Disease*, ed 2. Philadelphia, WB Saunders, 1979, pp 550-558.
- Soin JS, Cox JD, Youker JE, et al: Cardiac localization of ^{99m}Tc - (Sn) -pyrophosphate following irradiation of the chest. *Radiology* 124:165-168, 1977.
- Korsower JM, Skovron ML, Ghossein NA, et al: Acute changes in pulmonary arterial perfusion following irradiation. *Radiology* 100:691-693, 1971.
- Bateman NT, Croft DN: False-positive lung scans and radiotherapy. *Br Med J* 1:807-808, 1976.
- Sarreck R, Sham R, Alexander LL, et al: Increased ^{99m}Tc -pyrophosphate uptake with radiation pneumonitis. *Clin Nucl Med* 4:403-404, 1979.
- Freeman CR, Lisbona R, Palayow M: Lung scanning with ^{67}Ga citrate for detection of acute radiation changes. *J Can Assoc Radiol* 33:25-27, 1982.
- Siemsen JK, Grebe SF, Waxman AD: The use of gallium-67 in pulmonary disorders. *Semin Nucl Med* 8:235-249, 1978.
- Usselman JA: Liver scanning in the assessment of liver damage from therapeutic external irradiation. *J Nucl Med* 7:761-762, 1966.
- Gilday DL, Alderson PO: Scintigraphic evaluation of liver and spleen injury. *Semin Nucl Med* 4:357-370, 1974.
- Ingold JA, Reed GB, Kaplan HS, et al: Radiation hepatitis. *AJR* 93:200-208, 1965.
- Gelfand MJ, Saha S, Aron BS: Imaging of irradiated liver with Tc-^{99m} -sulfur colloid and Tc-^{99m} -IDA. *Clin Nucl Med* 6:399-402, 1981.
- Herbst KD, Corder MP, Morita ET: Hepatic scan defects following radiotherapy for lymphoma. *Clin Nucl Med* 3:331-333, 1978.
- Samuels LD, Grosfeld JL, Kartha M: Reversal of liver scan image after right-sided renal radiotherapy. *JAMA* 215:1816-1818, 1971.
- Spencer RP, Knowlton AH: Redistribution of radiocolloid uptake after focal hepatic irradiation. *Oncology* 32:266, 1975.
- Spencer RP, Karimeddini MK: Hepatic "boomerang" appearance after radiation for carcinoma of the pancreas. *Clin Nucl Med* 7:299, 1982.
- Lutrin CL, Goris ML: Pyrophosphate retention by previously irradiated renal tissue. *Radiology* 133:207-209, 1979.
- Wistow BW, McAfee JG, Sagenman RH, et al: Renal uptake of ^{99m}Tc methylene diphosphonate after radiation therapy. *J Nucl Med* 20:32-34, 1979.
- King MA, Casarett GW, Weber DA: A study of irradiated bone: I. Histopathologic and physiologic changes. *J Nucl Med* 20:1142-1149, 1979.
- King MA, Weber DA, Casarett GW, et al: A study of irradiated bone: II. Changes in Tc-^{99m} -pyrophosphate bone imaging. *J Nucl Med* 21:22-30, 1980.
- Lind MG, Nathanson A: ^{99m}Tc -DP accumulation in rabbit skull bones after ^{60}Co gamma irradiation. *Acta Radiol (Ther)* 16:489-496, 1977.
- Sorkin SI, Horii SC, Passalacqua A, et al: Decreased activity on a bone scan following therapeutic radiation: a source of possible error. *Clin Nucl Med* 3:67, 1978.
- Cox PH: Abnormalities in skeletal uptake of ^{99m}Tc polyphosphate complexes in areas of bone associated with tissues which have been subjected to radiation therapy. *Br J Radiol* 47:851-856, 1974.
- Vieras F: Radiation induced skeletal and soft tissue bone scan changes. *Clin Nucl Med* 2:93-94, 1977.
- Bekier A: Extraosseous accumulation of ^{99m}Tc -pyrophosphate in soft tissue after radiation therapy. *J Nucl Med* 19:225-226, 1978.
- Gillespie PJ, Alexander JL, Edelstyn GA: Changes in ^{87m}Sr concentrations in skeletal metastases in patients responding to cyclical combination chemotherapy for advanced breast cancer. *J Nucl Med* 16:191-193, 1975.
- Nelson B, Hayes RL, Edwards CL, et al: Distribution of gallium in human tissues after intravenous administration. *J Nucl Med* 13:92-100, 1972.
- Nelp WB, Gohil MN, Larson SM: Long-term effects of local irradiation of the marrow on erythron and red cell function. *Blood* 36:617-622, 1970.
- Knospe WH, Rayudu VM, Cardello M, et al: Bone marrow scanning with ^{51}Cr (^{51}Cr): Regeneration and extension of marrow after ablative doses of radiotherapy. *Cancer* 37:1432-1442, 1976.
- Steere HA, Lillcrap SC, Clink HM, et al: The recovery of iron uptake in erythropoietic bone marrow following large field radiotherapy. *Br J Radiol* 52:61-66, 1979.
- Rubin P, Scarantino CW: The bone marrow organ: the critical structure in radiation-drug interaction. *Int J Radiat Oncol Biol Phys* 4:3-23, 1978.
- Siddiqui AR, Oseas RS, Wellman HN, et al: Evaluation of bone-marrow scanning with technetium- 99m sulfur colloid in pediatric oncology. *J Nucl Med* 20:379-386, 1979.
- Bell EG, McAfee JG, Constable WC: Local radiation damage to bone and marrow demonstrated by radioisotopic imaging. *Radiology* 92:1083-1088, 1969.
- DeGowin RL, Chaudhuri TK, Christie JH, et al: Marrow scanning in evaluation of hemopoiesis after radiotherapy. *Arch Intern Med* 134:297-303, 1974.
- Gonzalez-Villalpando C, Frohman LA, Bekerman C, et al: Scintigraphic thyroid abnormalities after radiation. *Ann Intern Med* 97:55-58, 1982.
- Bekerman C, Hoffer PB: Salivary gland uptake of ^{67}Ga -citrate following radiation therapy. *J Nucl Med* 17:685-687, 1976.
- Lentle BC, Jackson FI, McGowan DG: Localization of gallium-67 citrate in salivary glands following radiation therapy. *J Can Assoc Radiol* 27:89-91, 1976.
- Rose J: Increased salivary gland uptake of ^{67}Ga -citrate

BLOOD TRANSFUSION

Blood transfusion, inasmuch as it may cause iron overload, has been found to influence the stability of ^{99m}Tc -MDP and, to a lesser extent, ^{99m}Tc -pyrophosphate. The result is poor bone visualization and marked renal uptake of the ^{99m}Tc , which possibly reflects the formation of such a chelate as ^{99m}Tc -labeled iron ascorbate (84).

CHEMOPERFUSION

Chemoperfusion has been observed to cause marked uptake of a bone scanning agent in the perfused limb (85).

IMMUNOTHERAPY

Immunotherapy has been employed in the treatment of cancers. We have noted that patients treated with *Bacillus Calmette-Guérin* (BCG) may develop a systemic granulomatosis (86). In both patients and experimental animals, this granulomatosis is associated with changes in the biodistribution of radiogallium that are particularly evident as abnormal lung uptake of that tracer (87, 88). Local sites of injection of an immune stimulant such as *Corynebacterium parvum* have also been reported to result in uptake of radiogallium (63).

RENAL DIALYSIS

On the basis of a series of images made with ^{67}Ga -citrate in patients on renal dialysis and showing little liver uptake and marked uptake in bone, we had suspected that dialysis might interfere with the biodistribution of radiogallium (1). Detailed studies have not confirmed this (89, 90), and the finding may have related to renal bone disease.

Transient abnormalities found on the brain scans of patients on dialysis have been reported (91).

DeGraaf et al. (92), in a study made to determine the sensitivity of ^{99m}Tc -hydroxyethylidene diphosphonate (HEDP) in detecting gastric calcification complicating chronic renal failure, found that the radiochemical interacted with saline and the dialysate fluid to form free pertechnetate. This resulted in the predictable uptake of the pertechnetate by stomach, thyroid, and salivary glands (92).

INADVERTENTLY ALTERED ROUTES OF ADMINISTRATION OF RADIOPHARMACEUTICALS

Occasionally, a radiotracer is injected intra-arterially which may result in an abnormal scintigraph (1, 93). The nature of the abnormality will be influenced by the physical form of the tracer; e.g., ^{99m}Tc -MAA will be virtually entirely extracted in the periphery, whereas ^{99m}Tc -labeled phosphates merely show unusual concentrations in tissues to which they are delivered in high concentrations.

An interstitial injection has recently been reported (94) to result in lymph node visualization presumably due to a volume effect, as the tracer (^{99m}Tc -MDP) was not one that might have been expected to be extracted by the cells in such a node.

Radiotracers that are rapidly or effectively extracted are more prone to provide bizarre radiotracer biodistributions. An example resulting from the injection of ^{99m}Tc -MAA into a pulmonary artery catheter has been reported (95).

A trivial example but one with considerable practical implications is the development of a cerebrospinal fluid leak after lumbar puncture which can both result from and be imaged by tracer studies (96). This leak can result in chronic and distressing headaches (97) and is readily treated by a "blood patch" (98).

CONCLUSION

A variety of iatrogenic physical and other insults causing changes identifiable on radionuclide images are described. The nature of these abnormalities and the profusion of isolated reports concerning them may, at first, be intimidating. Most, if not all, of these abnormalities, however, might be anticipated from an understanding of disease processes, from a knowledge of the particular patient, and from insight into the mechanisms of radiopharmaceutical localization. Therefore, this review merely emphasizes the importance of understanding radionuclide scans as an aspect of patient care and not as abstract exercises divorced from the human beings with whom we work.

ACKNOWLEDGMENTS

We are indebted to Dr. P. G. Heslip of the University of Alberta Hospital, Edmonton, for

Figure 15.5, to Mr. Karl Liesner for preparing the illustrations, and to Mrs. M. Laschowski and Mrs. E. Dolina for typing the manuscript.

REFERENCES

- Lentle BC, Scott JR, Noujaim AA, et al: Iatrogenic alterations in radionuclide biodistributions. *Semin Nucl Med* 9:131-143, 1979.
- Hladik WB III, Nigg KK, Rhodes BA: Drug-induced changes in the biologic distribution of radiopharmaceuticals. *Semin Nucl Med* 12:184-218, 1982.
- Robbins SL, Cotran RS: *Pathologic Basis of Disease*, ed 2. Philadelphia, WB Saunders, 1979, pp 550-558.
- Soin JS, Cox JD, Youker JE, et al: Cardiac localization of ^{99m}Tc - (Sn) -pyrophosphate following irradiation of the chest. *Radiology* 124:165-168, 1977.
- Korsower JM, Skovron ML, Ghossein NA, et al: Acute changes in pulmonary arterial perfusion following irradiation. *Radiology* 100:691-693, 1971.
- Bateman NT, Croft DN: False-positive lung scans and radiotherapy. *Br Med J* 1:807-808, 1976.
- Sarreck R, Sham R, Alexander LL, et al: Increased ^{99m}Tc -pyrophosphate uptake with radiation pneumonitis. *Clin Nucl Med* 4:403-404, 1979.
- Freeman CR, Lisbona R, Palayew M: Lung scanning with ^{67}Ga citrate for detection of acute radiation changes. *J Can Assoc Radiol* 33:25-27, 1982.
- Siemsen JK, Grebe SF, Waxman AD: The use of gallium-67 in pulmonary disorders. *Semin Nucl Med* 8:235-249, 1978.
- Usselman JA: Liver scanning in the assessment of liver damage from therapeutic external irradiation. *J Nucl Med* 7:761-762, 1966.
- Gilday DL, Alderson PO: Scintigraphic evaluation of liver and spleen injury. *Semin Nucl Med* 4:357-370, 1974.
- Ingold JA, Reed GB, Kaplan HS, et al: Radiation hepatitis. *AJR* 93:200-208, 1965.
- Gelfand MI, Saha S, Aron BS: Imaging of irradiated liver with Tc-99m-sulfur colloid and Tc-99m-IDA. *Clin Nucl Med* 6:399-402, 1981.
- Herbst KD, Corder MP, Morita ET: Hepatic scan defects following radiotherapy for lymphoma. *Clin Nucl Med* 3:331-333, 1978.
- Samuels LD, Grosfeld JL, Kartha M: Reversal of liver scan image after right-sided renal radiotherapy. *JAMA* 215:1816-1818, 1971.
- Spencer RP, Knowlton AH: Redistribution of radiocolloid uptake after focal hepatic irradiation. *Oncology* 32:266, 1975.
- Spencer RP, Karimeddini MK: Hepatic "boomerang" appearance after radiation for carcinoma of the pancreas. *Clin Nucl Med* 7:299, 1982.
- Lutrin CL, Goris ML: Pyrophosphate retention by previously irradiated renal tissue. *Radiology* 133:207-209, 1979.
- Wistow BW, McAfee JG, Sagerman RH, et al: Renal uptake of ^{99m}Tc methylene diphosphonate after radiation therapy. *J Nucl Med* 20:32-34, 1979.
- King MA, Casarett GW, Weber DA: A study of irradiated bone: I. Histopathologic and physiologic changes. *J Nucl Med* 20:1142-1149, 1979.
- King MA, Weber DA, Casarett GW, et al: A study of irradiated bone: II. Changes in Tc-99m-pyrophosphate bone imaging. *J Nucl Med* 21:22-30, 1980.
- Lind MG, Nathanson A: ^{99m}Tc -DP accumulation in rabbit skull bones after ^{60}Co gamma irradiation. *Acta Radiol (Ther)* 16:489-496, 1977.
- Sorkin SJ, Horii SC, Passalacqua A, et al: Decreased activity on a bone scan following therapeutic radiation: a source of possible error. *Clin Nucl Med* 3:67, 1978.
- Cox PH: Abnormalities in skeletal uptake of ^{99m}Tc polyphosphate complexes in areas of bone associated with tissues which have been subjected to radiation therapy. *Br J Radiol* 47:851-856, 1974.
- Vieras F: Radiation induced skeletal and soft tissue bone scan changes. *Clin Nucl Med* 2:93-94, 1977.
- Bekier A: Extraosseous accumulation of ^{99m}Tc -pyrophosphate in soft tissue after radiation therapy. *J Nucl Med* 19:225-226, 1978.
- Gillespie PJ, Alexander JL, Edelstyn GA: Changes in ^{87}Sr concentrations in skeletal metastases in patients responding to cyclical combination chemotherapy for advanced breast cancer. *J Nucl Med* 16:191-193, 1975.
- Nelson B, Hayes RL, Edwards CL, et al: Distribution of gallium in human tissues after intravenous administration. *J Nucl Med* 13:92-100, 1972.
- Nelp WB, Gohil MN, Larson SM: Long-term effects of local irradiation of the marrow on erythron and red cell function. *Blood* 36:617-622, 1970.
- Knospe WH, Rayudu VM, Cardello M, et al: Bone marrow scanning with ^{59}Fe (^{59}Fe): Regeneration and extension of marrow after ablative doses of radiotherapy. *Cancer* 37:1432-1442, 1976.
- Steere HA, Lillierap SC, Clink HM, et al: The recovery of iron uptake in erythropoietic bone marrow following large field radiotherapy. *Br J Radiol* 52:61-66, 1979.
- Rubin P, Scarrantino CW: The bone marrow organ: the critical structure in radiation-drug interaction. *Int J Radiat Oncol Biol Phys* 4:3-23, 1978.
- Siddiqui AR, Oseas RS, Wellman HN, et al: Evaluation of bone-marrow scanning with technetium-99m sulfur colloid in pediatric oncology. *J Nucl Med* 20:379-386, 1979.
- Bell EG, McAfee JG, Constable WC: Local radiation damage to bone and marrow demonstrated by radioisotopic imaging. *Radiology* 92:1083-1088, 1969.
- DeGowin RL, Chaudhuri TK, Christie JH, et al: Marrow scanning in evaluation of hemopoiesis after radiotherapy. *Arch Intern Med* 134:297-303, 1974.
- Gonzalez-Villalpando C, Frohman LA, Bekerman C, et al: Scintigraphic thyroid abnormalities after radiation. *Ann Intern Med* 97:55-58, 1982.
- Bekerman C, Hoffer PB: Salivary gland uptake of ^{67}Ga -citrate following radiation therapy. *J Nucl Med* 17:685-687, 1976.
- Lentle BC, Jackson FI, McGowan DG: Localization of gallium-67 citrate in salivary glands following radiation therapy. *J Can Assoc Radiol* 27:89-91, 1976.
- Rose J: Increased salivary gland uptake of ^{67}Ga -citrate

- 36 months after radiation therapy. *J Nucl Med* 18:495-496, 1977.
40. Fletcher JW, Herbig FK, Donati RM: ^{67}Ga citrate distribution following whole-body irradiation or chemotherapy. *Radiology* 117:709-712, 1975.
 41. Bradley WP, Alderson PO, Eckehnan WC, et al: Decreased tumor uptake of gallium-67 in animals after whole-body irradiation. *J Nucl Med* 19:204-209, 1978.
 42. Swartzendruber DC, Hubner KF: Effect of external whole-body x-irradiation on gallium-67 retention in mouse tissues. *Radiat Res* 55:457-468, 1973.
 43. Sephton R, Martin JJ: Modification of distribution of gallium 67 in man by administration of iron. *Br J Radiol* 53:572-575, 1980.
 44. Sephton RG, De Abrew S, Hodgson GS: Mechanisms of distribution of gallium 67 in mouse tumor hosts. *Br J Radiol* 55:134-141, 1982.
 45. Bitran JD, DeMeester TR, Rezai-Zadeh K, et al: Clinicopathologic correlations demonstrating the failure of ^{67}Ga scanning in determining response to radiotherapy. *Chest* 73:356-359, 1978.
 46. Kondo M, Hashimoto S, Kubo A, et al: ^{67}Ga scanning in the evaluation of esophageal carcinoma. *Radiology* 131:723-726, 1979.
 47. Emrich D, Willgeroth F, Bargon G: The influence of radiation and cyclophosphamide on tumor uptake of ^{201}Tl under experimental conditions. *Int J Nucl Med Biol* 1:23-27, 1973.
 48. Rosenthal L, Greyson ND, Eidinger SL: Positive identification of lung neoplasms with $^{197}\text{HgCl}_2$. *J Can Assoc Radiol* 21:181-183, 1970.
 49. Coleman CN, McDougall IR, Dailey MO, et al: Functional hyposplenism after splenic irradiation for Hodgkin's disease. *Ann Intern Med* 96:44-47, 1982.
 50. Spencer RP, Pearson HA, Binder HJ: Identification of cases of acquired functional asplenia. *J Nucl Med* 11:763-766, 1970.
 51. Spencer RP, Dhawan V, Suresh K, et al: Causes and temporal sequence of onset of functional asplenia in adults. *Clin Nucl Med* 3:17-18, 1978.
 52. Rao BR, Winebright JW, Dresser TP: Functional asplenia after Thorotrast administration. *Clin Nucl Med* 4:437-438, 1979.
 53. Burroughs AK, Bass NM, Wood J, et al: Absence of splenic uptake of radiocolloid due to Thorotrast in a patient with Thorotrast-induced cholangiocarcinoma. *Br J Radiol* 55:598-600, 1982.
 54. Eng RR, Ege GN, Durakovic A, et al: Altered uptake of $^{99\text{m}}\text{Tc}$ antimony sulfide colloid by lymph nodes post-irradiation (abstract). *J Nucl Med* 24:95, 1983.
 55. Boal DK, Newburger PE, Teele RL: Esophagitis induced by combined radiation and adriamycin. *AJR* 132:567-570, 1979.
 56. Sty JR, Starshak RJ, Lauer SJ: Polymucositis: a cause of Ga-67 uptake. *Clin Nucl Med* 6:126, 1981.
 57. Thrall JH, Ghaed N, Geslien CE: Pitfalls in $^{99\text{m}}\text{Tc}$ polyphosphate skeletal imaging. *AJR* 121:739-747, 1974.
 58. Wells LD, Bernier DR: *Radionuclide Imaging Artifacts*. Chicago, Year Book Medical Publishers, 1980, pp 104-105.
 59. Siddiqui AR, Stokka CL: Uptake of $^{99\text{m}}\text{Tc}$ -methylene diphosphonate in a surgical scar. *Clin Nucl Med* 5:274, 1980.
 60. Silberstein EB, Schneider HJ, Khodadad G, et al: Laminectomy: effects on postoperative technetium and gallium scintigraphy. *Radiology* 151:785-787, 1984.
 61. Carter JE, Joo KG: Gallium accumulation in intramuscular injection sites. *Clin Nucl Med* 4:304, 1979.
 62. Brill DR: Radionuclide imaging of non-neoplastic soft tissue disorders. *Semin Nucl Med* 11:277-288, 1981.
 63. Leonard JC, Humphrey CB, Vanhoutte JJ: Positive ^{67}Ga -citrate scans in patients receiving *Corynebacterium parvum*. *Clin Nucl Med* 3:370-371, 1978.
 64. Van Antwerp JD, Hall JN, O'Mara RE: Bone scan abnormality produced by interaction of Tc-99m diphosphonate with iron dextran (Imferon). *J Nucl Med* 16:577, 1975.
 65. Byun HH, Rodman SG, Chung KE: Soft tissue concentration of $^{99\text{m}}\text{Tc}$ -phosphates associated with injections of iron-dextran complex. *J Nucl Med* 17:374-375, 1976.
 66. Sty JR, Starshak RJ, Hubbard AM: ^{67}Ga scintigraphy. Calcium gluconate extravasation. *Clin Nucl Med* 7:377, 1982.
 67. Tyler JL, Powers TA: Bone scanning after marrow biopsy: concise communication. *J Nucl Med* 23:1085-1087, 1982.
 68. Afazraki N, Moitiza J, Heaphy I, et al: The effect of iatrogenic trauma on the bone scintigram: an animal study: concise communication. *J Nucl Med* 25:978-981, 1984.
 69. Hurley PJ: Effect of craniotomy on the brain scan related to time elapsed after surgery. *J Nucl Med* 13:156-158, 1972.
 70. Eikman EA, Tenorio LE, Frank BA: Gallium-67 accumulation in the stomach in patients with postoperative gastritis (letter to editor). *J Nucl Med* 21:706-707, 1980.
 71. Abrenio JK, Jhingran SG, Johnson PC: Abnormal gallium-67 image of the abdomen in starch granulomatous disease (letter to editor). *J Nucl Med* 20:902-903, 1979.
 72. Newcomer AD, Wahner HW: Gallium scan: clue to the diagnosis of starch peritonitis. *Clin Nucl Med* 4:465-467, 1979.
 73. Hartshome MF, Maragh HA, Telepak RJ, et al: ^{67}Ga uptake in capsular contracture around a breast implant. *Clin Nucl Med* 7:572-573, 1982.
 74. Jayabalan V, Berry S: Accumulation of $^{99\text{m}}\text{Tc}$ -pyrophosphate in breast prosthesis. *Clin Nucl Med* 2:452-453, 1977.
 75. Seo I, Donoghue G: Tc-99m pyrophosphate accumulation on prosthetic valves. *Clin Nucl Med* 5:367-369, 1980.
 76. Fordham EW, Ali A, Turner DA, Charters JR (eds): *Atlas of Total Body Radionuclide Imaging*. Philadelphia, Harper & Row, vol 1, 1982, p 256.
 77. Lentle BC, Glazebrook GA, Percy JS, et al: Sympathetic denervation and the bone scan. *Clin Nucl Med* 2:276-278, 1977.
 78. Sagar V, Piccone JM, Charles ND, et al: Skeletal tracer uptake and bone blood flow in dogs (abstract). *J Nucl Med* 19:705-706, 1978.
 79. Ege GN: Internal mammary lymphoscintigraphy. The rationale, technique, interpretation and clinical application: a review based on 848 cases. *Radiology* 118:101-107, 1976.
 80. Slutsky LJ, Passalacqua AM, Oster ZH, et al: Uptake of $^{99\text{m}}\text{Tc}$ pyrophosphate in chest wall tissues due to defibrillation. *Clin Nucl Med* 2:6-7, 1977.
 81. Pugh BR, Buja LM, Parkey RW: Cardioversion and "false positive" technetium-99m-stannous pyrophosphate myocardial scintigrams. *Circulation* 54:399-402, 1976.
 82. DiCola VC, Freedman GS, Downing SE et al: Myocardial uptake of technetium-99m-stannous pyrophosphate following direct current transthoracic countershock. *Circulation* 54:980-986, 1976.
 83. Goldfarb CR, Shah PJ, Jay M: Extraosseous uptake of bone-seeking tracers: an expected but unsuspected addition to the list. *Clin Nucl Med* 4:194-195, 1979.
 84. Choy D, Murray IPC, Hoschl R: The effect of iron on the biodistribution of bone scanning agents in humans. *Radiology* 140:197-202, 1981.
 85. Sorokin SJ, Horii SC, Passalacqua A, et al: Augmented activity on a bone scan following local chemoperfusion. *Clin Nucl Med* 2:451, 1977.
 86. Bilji C, Brown NE, McPherson TA, et al: Pulmonary manifestations in patients with malignant melanoma during BCG immunotherapy. *Chest* 75:685-687, 1979.
 87. Shysh A, Mallet-Paret S, Lentle BC, et al: Influence of intradermal BCG on the biodistribution of radiogallium in mice. *Int J Nucl Med Biol* 7:333-336, 1980.
 88. Shysh A, Mallet-Paret S, Lentle BC, et al: Altered biodistribution of radiogallium following BCG treatment of mice. *Int J Nucl Med Biol* 8:349-356, 1981.
 89. Marlette JM, Ma KW, Shafer RB: Effect of hemodialysis on gallium-67 citrate scanning. *Clin Nucl Med* 5:401-403, 1980.
 90. Levine E, Tucker K, Cooper J: Impact of peritoneal dialysis on the biodistribution of gallium citrate-Ga67 (abstract). *Clin Nucl Med* 6(Suppl):150, 1981.
 91. Wolfstein RS, Tanasescu DE, Waxman AD, et al: Transient brain scan abnormalities in renal dialysis patients. *J Nucl Med* 17:6-8, 1976.
 92. DeGraaf P, Pauwels EKI, Schicht IM, et al: Scintigraphic detection of gastric calcification in dialysis patients. *Diagn Imaging* 48:171-176, 1979.
 93. Andrews GA, Theoccheung JL, Andrews E, et al: Unintentional intra-arterial injection of a bone-imaging agent. *Clin Nucl Med* 5:499-501, 1980.
 94. Penney HF, Styles CB: Fortuitous lymph node visualization after interstitial injection of Tc-99m-MDP. *Clin Nucl Med* 7:84-85, 1982.
 95. Brachman M, Tanasescu D, Ramanna L: False-positive lung imaging: inadvertent injection into a pulmonary artery catheter. *Clin Nucl Med* 4:415-416, 1979.
 96. Colletti PM, Siegel ME: Posttraumatic lumbar cerebrospinal fluid leak; detection by retrograde In-111 DTPA myeloscintigraphy. *Clin Nucl Med* 6:403-404, 1981.
 97. Gass H, Goldstein AS, Ruskin R, et al: Chronic postmyelogram headache: isotope demonstration of dural leak and surgical cure. *Arch Neurol* 25:168-170, 1971.
 98. Milette PC, Pagacz A, Charest C: Epidural blood patch for the treatment of chronic headache after myelography. *J Can Assoc Radiol* 33:236-238, 1982.

16

Normal Clinical Variation in Anatomic Structure and Physiologic Function and Its Effect on Radiopharmaceutical Biodistribution

John J. Coupal and E. Edmund Kim

The diagnostician must be familiar with normal variation if he is not to give his patients diseases which they do not have.

John Caffey (1)

Biological variation in humans implies a range of normal variants in structure and function. Thus, a limited spectrum of organ anatomic configurations is denoted as "normal" and consonant with health or, at least, with nondisease. Likewise, a limited range of physiologic norms (e.g., flow rate, excretory and secretory routes) characterizes organ or system function. Information on the most common normal variants in anatomic structure and physiologic function that are evident in nuclear medicine imaging studies are provided in this chapter.

LIVER AND SPLEEN

The liver is more prone to normal variation in structure than is any other organ in the human body (Fig. 16.1). This occurs, in part, due to the large size of the liver (the largest organ in the body), its location (hence, proximity to many other organs), its pliable nature, and its ability to regenerate itself (Fig. 16.2). Liver size usually is directly related to body surface area (2). Many anatomic characteristics of the liver and juxtahepatic structures can lead to a false positive radiocolloid liver scan, and these are listed in Table 16.1.

Riedel's lobe is a downward tongue-like extension of the right lobe of liver along the right end of the inferior margin (3). It extends down-

ward to the level of the umbilicus or below, possibly reaching the iliac crest. Although it is found more often in women than in men, it can occur in infants and children. Riedel's lobe was seen in 4% of 66 subjects whose hepatic scans were normal (4) and in 3.3% of another group of patients (86 of 2604; 60 females, 26 males) who had undergone hepatic imaging (5).

Normal spleen weight in a 20-year-old man is 146 ± 37 (mean \pm SD) gm (8). Spleen size in men decreases progressively until age 29 and then remains essentially constant until age 59, from which point it again progressively declines. Normal spleen weight in a 20-year-old woman is 120 ± 30 gm; spleen size in women follows a course that parallels that of the man. The configuration and the position of the normal spleen are extremely variable. Notching, septation, and one or more accessory spleens also can be found. Notching occurs superiorly (80–100%), inferiorly (30–60%), and anteriorly (3–15%) but rarely posteriorly or on the diaphragmatic surface (9). Notching, in and of itself, does not result in change of the normal orientation of the splenic hilus which is directed inframedially. Simpson et al. (10) reported on a man whose ^{99m}Tc -labeled sulfur colloid (^{99m}Tc -SC) scan revealed a defect in the upper pole of the spleen (10). Suspicion of an "upside-down" spleen led to performance of a combined radio-



"You're right, his liver is shaped like the fifth green at Burning Tree."

Figure 16.1. Reproduced courtesy of Bill Hoest and *Parade* magazine. © 1983.

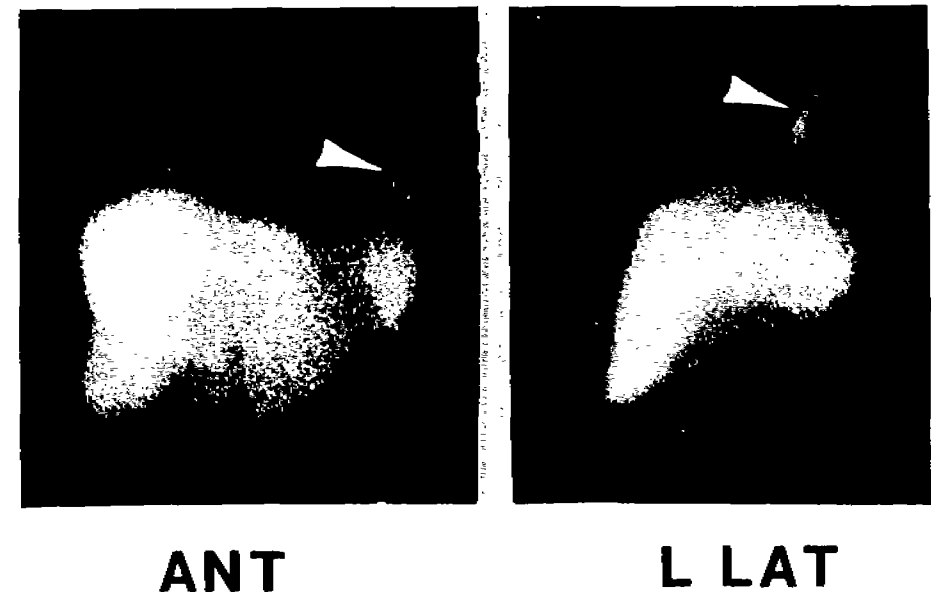

Figure 16.2. Anterior (ANT) and left lateral (L LAT) static images of liver and spleen made with ^{99m}Tc -labeled sulfur colloid show unusually prominent left lobe and abnormal focal activity (arrows) in the left lower lung posteriorly. Liver function tests and chest radiographs were normal.

Table 16.1.

Anatomic Causes of False Positive Radiocolloid Liver Scan*

Intrinsic anatomical variation
Enlarged hepatic fossa for porta hepatis, hepatic vein, inferior vena cava, ligamentum teres hepatis, and gallbladder
Thin left hepatic lobe
Large left hepatic lobe
Riedel's lobe of liver
Liebermeister's grooves on liver
Juxtahepatic structures attenuating liver radioactivity
Prominent rib cage
Pendulous breast
Right kidney
Lordotic spine
Prominent right psoas muscle
Dilated or displaced stomach

* Adapted from References 3-7.

nuclide imaging study of the stomach (oral sodium [^{99m}Tc]pertechnetate) and spleen (intravenous ^{99m}Tc -SC). It was thereby shown that the spleen was inverted and that the V-shaped splenic defect was filled in by ^{99m}Tc -pertechnetate* located in the horizontal fundus of the stomach.

CENTRAL NERVOUS SYSTEM

The normal brain scan in older children and preadolescents does not differ markedly from the normal brain scan in adults (11). In infants and very young children, however, the skull is thin with few osseous irregularities, and the scan has a delicate appearance. The small dimensions and relatively low mass of γ -photon-attenuating tissue in the infant's skull make "shine through" of distant or contralateral structures more pronounced, especially when a rectilinear scanner is used. Since the infant skull may have a triangular appearance in vertex view, difficulties in diagnosis may arise. A thick skull may yield symmetrical widening of the marginal rim of radioactivity.

The torcular herophili (evolved from the anterior dural plexus) and the lateral sinuses are

* Although [^{99m}Tc]pertechnetate is preferred by IUPAC, ^{99m}Tc -pertechnetate is standard, and both are used throughout this chapter.

readily seen in the brain scan made of a young child. They may not be seen in skull roentgenograms made of the same child. The normal torcular angle formed by the transverse sinuses and seen on the posterior view is $162 \pm 8^\circ$. Holmes and Golle (12) have reported that the transverse sinuses in normal patients were symmetrical in only 32 of 212 patients (15%). The right was larger than the left in 56%, and the left was larger than the right in 30%.

Normal separation of sutures or the presence of an open fontanelle in an infant does not yield an abnormal brain image (13).

Noninvasive regional cerebral blood flow (nrCBF) was measured in 15 normal humans by Meyer et al. with use of ^{133}Xe (14). The subjects included 9 men and 6 women who ranged in age from 23 to 62 years (mean, 36 years). Flow in gray matter was 85.4 ml/100 gm brain/min at age 23 and declined linearly thereafter at the rate of 0.53 ml/100 gm brain/min/yr of age ($r = -0.59, p < .05$). Flow in white matter at age 23 years was approximately 19 ml/100 gm brain/min and did not change with advancing age ($r = -0.42, p > .05$). The relative weight of gray matter was 46.3% at age 23 years, and progressively declined at the rate of 0.32%/yr thereafter ($r = -0.62, p < .02$). Cerebral vascular resistance increased progressively after age 23 years, although none of the subjects (a) was hypertensive, (b) had evidence of arteriosclerosis, or (c) had any arteriosclerosis risk factors. This study shows that gray matter blood flow and the weight of gray matter progressively decline with advancing age. Such observations agree well with the progressive loss of cortical neurones noted in normal individuals of advancing age who came to autopsy (15). A venous reflux of radioactivity is often elicited by the Valsalva maneuver.

Certain anatomic or physiologic variants cause false positive brain scans. Examples of these variants are shown in Table 16.2.

PANCREAS

Certain nonpathologic structures cause falsely abnormal pancreatic scans (16). These are (a) thinning of the area where pancreas passes over the spine and (b) obscuring of the pancreas by overlying organs.

Table 16.2.

Anatomic or Physiologic Causes of False Positive Brain Scan*

Coronal or lambdoidal suture
Middle meningeal veins anterior to the sella
Asymmetry in the lateral sinuses (the right usually shows greater radioactivity than does the left)
Draining surface veins
Choroid plexus if perchlorate is not given
Salivary glands
Large occipital sinus

* Adapted from Reference 16.

BONE

Each of 150 female patients with breast carcinoma received a whole-body bone scan with ^{99m}Tc -etidronate (HEDP) (17). The bone scan was negative for all patients, and this group comprised the control. A region of interest around the second lumbar vertebra (bone) and in an area just below the kidney and clear of the spine and pelvis (soft tissue) were isolated on the CRT display of the lumbosacral spine. The ratio of bone to soft tissue (B/ST) was computed with use of relative counts in the respective regions of interest. The average B/ST ratios partitioned by age of patients are shown in Table 16.3.

When the ratios from the age decades were compared, the only statistically significant differences were between the 51-60-year group and each of the 61-70- and the 71-80-year groups ($p < .01$). The authors state that a lower B/ST ratio in patients over 60 years of age is understandable in light of reduced bone mass and of histologic evidence of reduced osteoblastic activity as one grows older.

Table 16.3.

Ratio of Bone to Soft Tissue by Age of Patient*

Age Range (yr)	No. of Patients	Ratio of Bone to Soft Tissue	
		Median	Observed Range
30-40	15	3.90	2.08-5.40
41-50	51	4.10	2.70-5.80
51-60	43	4.30	3.20-6.00
61-70	34	3.90	2.40-5.90
71-80	7	3.70	3.10-4.00

* Adapted from Reference 17.

The quality of the ^{99m}Tc -phosphate or phosphonate bone scan is partially dependent on the age of the patient: the older the patient, the lower the quality of the scan (18-20).

Accumulation of bone-seeking radiopharmaceuticals in normal osseous or extraosseous structures may show as false positive scans (Table 16.4). For example, hepatobiliary excretion of bone-imaging radiopharmaceutical may occur as an alternate route to urinary excretion (Fig. 16.3).

Radioactivity concentration in the anterior lower neck on a ^{99m}Tc -phosphate bone scan sometimes is attributed to pertechnetate from the radiopharmaceutical in the thyroid gland. In reality, such uptake can be due to the presence of radiopharmaceutical in thyroid cartilage (22-23) or cricoid cartilage (23-24). A determination of the actual site requires consideration of shape of uptake, location of uptake (revealed by comparison of scan with roentgenogram of the neck), and presence of ancillary uptake characteristic of pertechnetate biodistribution. The reason for variability in incidence of cartilaginous radioactivity is unclear.

THYROID

The normal thyroid gland has a butterfly appearance on a radionuclide scan. Sometimes, the isthmus connecting the two lobes may not be seen. A pyramidal lobe extending from the medial aspect of one of the upper poles is seen occasionally. Infrequently, one lobe may be substantially larger than the other and may dominate the scan pattern (25). Rarely, an entire thyroid lobe may be missing as a result of agen-

Table 16.4.

Anatomic and Physiologic Causes of False Positive Bone Scan*

Growing epiphysis and apophysis
Cartilage uptake
Shoulder uptake increased on side of dominant handedness
Multiple sternal ossification centers
Breast uptake
Deltoid tuberosity
Hyperostosis frontalis

* Adapted from References 21-24.

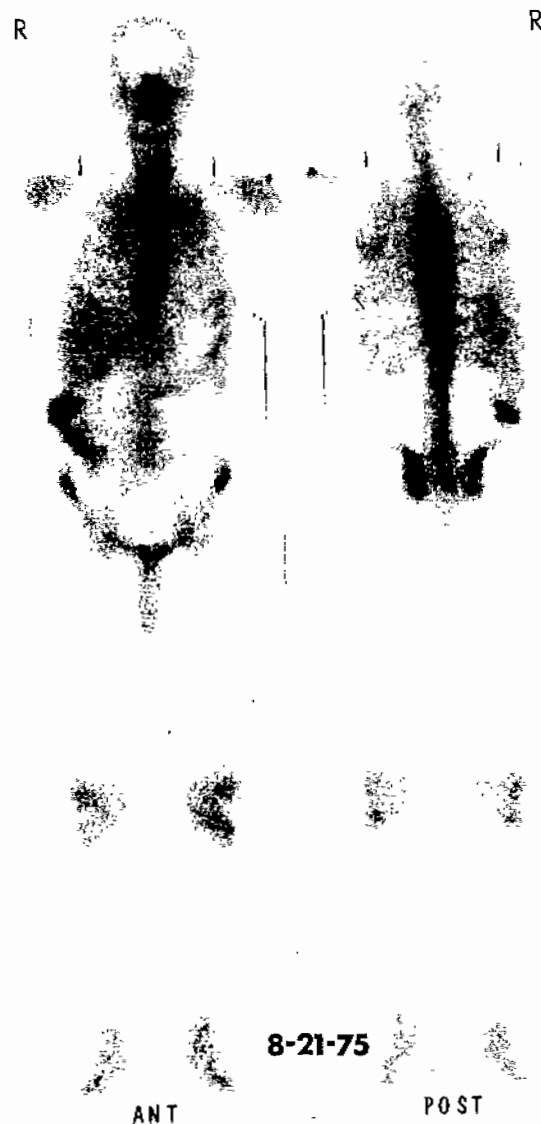

Figure 16.3. Anterior (*ANT*) and posterior (*POST*) whole-body bone images with ^{99m}Tc -pyrophosphate show unusual activities in the liver and probably the large bowel. Note that there is no activity in the stomach but significant activity in the genital organ. There was no history of previous radionuclide study. No liver or intestinal disease was found.

esis; agenesis of the left lobe is more common. A sublingual or single lobe in the midline can be identified occasionally (Fig. 16.4).

Since $^{99m}\text{TcO}_4^-$ is taken up and secreted by the salivary glands, esophageal retention of sali-

vary secretion of pertechnetate may yield an artifact that could suggest a substernal thyroid. In contrast, since salivary secretion of iodide occurs to a lesser degree than does salivary secretion of pertechnetate (26–27), an ^{131}I scan

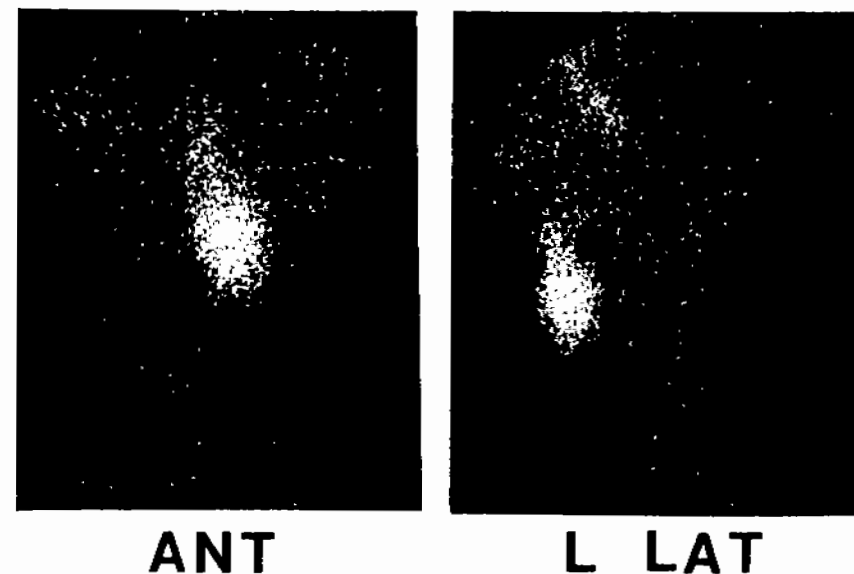

Figure 16.4. Anterior (*ANT*) and left lateral (*L LAT*) views of the neck made with ^{99m}Tc -pertechnetate show a single lobe of the thyroid in the midline of middle neck.

probably would be normal. If there is any extension of radioactivity on the $^{99m}\text{TcO}_4^-$ image below or above the thyroid gland (especially along the left lobe), one should suspect tracer accumulation in the esophagus (28). Verification of this phenomenon could be achieved by anterior scintigraphy performed while the patient swallows a dilute pertechnetate solution (Figs. 16.5 and 16.6).

Analogous to this situation, three false positive ^{131}I total-body scans have been reported (29). Radioiodide in salivary secretions within the esophagus has the potential to indicate metastatic disease. Having the patient drink water removes the esophageal radioactivity.

BREAST

Breast radioactivity on images results from concentration of radionuclides by mammary tissue. This phenomenon is most pronounced during lactation. There is considerable variation between women, however, in excretion of a radionuclide in the milk. This has been shown for ^{99m}Tc -pertechnetate (30, 31) and $[^{67}\text{Ga}]$ gallium citrate (32, 33).

Absolute levels of radioactivity in milk and resultant breast radioactivity on image vary from person to person, depending on (a) the efficiency of the concentrating mechanism for the radionuclide (which is possibly under hormonal influence), (b) the stage of lactation (i.e., during the perinatal period or a later period), and (c) the resulting volume of milk flow.

For example, in two lactating women receiving sodium $[^{99m}\text{Tc}]$ pertechnetate intravenously for thyroid imaging, the concentration of ^{99m}Tc in milk reached a peak at 2–3 hours postinjection and thereafter displayed biologic half-lives of 7.6 and 9.1 hours, respectively (34). The biologic half-life for ^{67}Ga in human milk is reported to be 9 days (33). Therefore, in lactating women receiving $[^{67}\text{Ga}]$ gallium citrate it is especially prudent to periodically withdraw and discard milk from the breasts by breast pump before total-body imaging.

KIDNEY

In the human fetus, the number of nephrons increases steadily from the sixth to thirty-sixth week of gestation. From 36 weeks until 12 years

of age, growth of the kidney results from maturation of existing nephrons (35). By 22 weeks gestation, all renal glomeruli are near to or adjoining the medulla (36). As time elapses, development of glomeruli proceeds toward the capsule. During development, there are always more mature nephrons near the medulla than in the outer cortex.

Functionally, there is decreased renal blood flow in the perinatal kidney. This decrease may be associated with lower arterial pressures as well as with enhanced renal vascular resistance. Measurement of effective renal plasma flow (ERPF) with use of *p*-aminohippuric acid (PAH) reveals normal values of 20–40% of those found in the adult. The resulting filtration fraction is

about 0.4 in the neonate (37). Other investigators report that extraction of PAH during passage through the kidneys is 60% and 91%, respectively, in infants 3 months old and in older children (38). The revealed filtration fraction of 0.23 remains slightly higher than that in the adult. Although maximal tubular transport of PAH is much lower in the newborn infant than in the adult, adult values are reached by approximately 7.5 months of age (39).

In the older child and adult, the renal cortex (representing 70% of renal mass) receives 75–95% of total renal blood flow (39). Medullary blood flow is one-third to one-sixth that of cortical blood flow and diminishes progressively from the juxtamedullary region toward

the apex of the medullary pyramids. Since blood passes through the glomeruli before reaching the medulla, renal radiopharmaceuticals must reach the medulla after transversing the cortex. Such transit pattern is altered in the neonate due to the greater medullary blood flow during that stage of life. Bell et al. (39) have

questioned whether such altered blood flow would affect parameters of standard radionuclide renal function tests.

A renal normal variant will accumulate ^{99m}Tc -gluceptate after a short vascular phase (Fig. 16.7). A true mass will demonstrate no radioactivity and will be considered a "cold

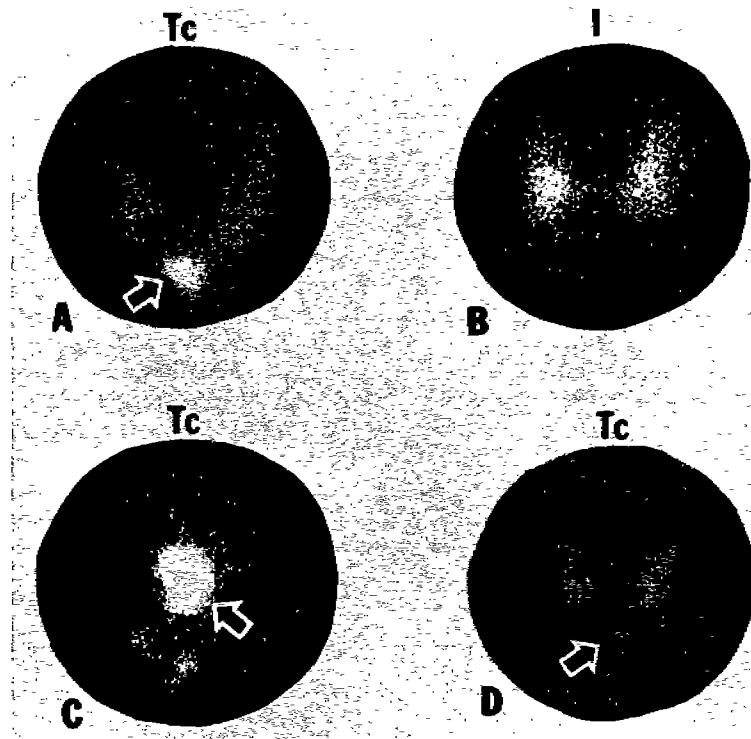

Figure 16.5. Anterior image of ^{99m}Tc thyroid scan (A) with the patient in supine position shows a focal oval-shaped activity simulating a hot nodule just below the isthmus (*open arrow*). Subsequent ^{131}I thyroid scan (B) fails to show any abnormality. Anterior neck image (C) of the patient after swallowing some Cream of Wheat cereal mixed with ^{99m}Tc -pertechnetate shows focal activity retained in the esophageal segment. Repeated ^{99m}Tc thyroid scan (D) with the patient in the upright position shows less activity accumulated in the esophageal segment (*open arrow*).



Figure 16.6. Oblique (*left*) and frontal (*right*) views of the barium swallow for the same patient as in Figure 16.5 show slight extrinsic indentation of the esophageal segment due to an anomalous aortic arch. No evidence of Zenker's diverticulum is noted.

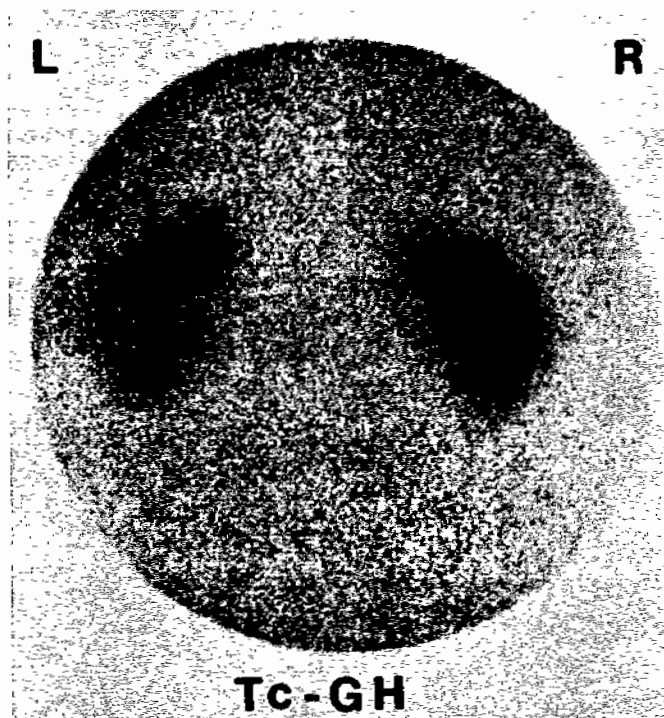

Figure 16.7. Posterior static renal image made with ^{99m}Tc -glucoheptonate (glucoptate) (*Tc-GH*) shows focal areas of relatively increased activities in the upper portion of both kidneys. Mass lesions without obstructive uropathy were suggested, on intravenous pyelogram, but a renal sonogram was negative.

area." With use of ^{99m}Tc -glucoptate scintigraphy, a true normal variant (true negative) was found in 17 of 40 patients with excretory urographic findings indicating a possible mass lesion and was confirmed with use of another modality (surgery, autopsy, or other imaging procedure) (40). A prominent column of Bertini was one of these true negative scintigraphic studies. Of the 4 false positives (comprising 10% of the group), 2 were interpreted with sub-optimal techniques (1 in which a scar defect was misinterpreted as a possible mass). In the third, there was merely bilaterally diminished peripelvic radioactivity. In the fourth, reduced tracer radioactivity in the lower pole was associated only with a separate (accessory) lower pole renal artery on arteriography. Peripelvic lesions are difficult to evaluate by scintigraphy because

of the normal defects produced by renal hilar fat and other hilar structures. Computed tomography is recommended for lesion detection in that area. With peripheral parenchymal bulges and the more central "masses" that distort the calyces and could be either true masses or prominent columns of Bertini, scintigraphy is best.

Horseshoe kidney and crossed renal ectopia are variants seen fairly often. Kidneys in aberrant locations such as the pelvis are readily seen on renal scintigrams. Congenital absence of a kidney is a rare condition. A uniformly small renal artery suggests a congenital small kidney.

Rao et al. (41) reported that with use of ^{99m}Tc -dimercaptosuccinate, a false positive image with the patient in the prone position was seen due to anterior displacement of the upper pole of the left kidney. The abnormality can be

avoided by routinely obtaining all renal images with the patient in the supine position and the detector behind the patient.

ADRENAL GLAND

In approximately two thirds of a group of normal subjects receiving NP-59, the radioactivity of the right adrenal gland appears greater than that of the left adrenal gland on the posterior view. This difference is probably associated with a slightly posterior right adrenal gland and superimposed radioactivity of the liver due to higher right adrenal gland. A variation of up to 43% was seen in the percent uptakes between the right and the left adrenal gland, respectively.

HEART

In normal subjects, an abnormality of [^{201}Tl]thallous chloride distribution at the apex of the heart may be associated with normal muscle thinning, not an abnormality of myocardial perfusion. The diaphragm has been shown to attenuate photons originating from the inferior myocardial segment when the patient is in the supine position for the left lateral view, with a resultant apparent defect (42).

^{99m}Tc -pyrophosphate scintigraphy for detecting myocardial infarction is a very sensitive but not a highly specific procedure. Fetz et al. (43) reported on the relative incidence of positive scintigraphic results in the absence of acute coronary artery-mediated myocardial necrosis. This incidence is shown in Table 16.5.

Table 16.5.

Anatomic and Physiologic Causes of False Positive ^{99m}Tc -Pyrophosphate Myocardial Images

Common
Persistent apparent blood pool radioactivity
Radioactivity adherence to vessel endothelium
Less common
Dystrophic cardiac calcification
Valvular
Coronary artery
Pericardial
Left ventricular dyssynergy
Normal breast tissue
Rare
Calcified costal cartilage

LUNG

Lung radioactivity seen on ^{99m}Tc -labeled sulfur colloid liver and spleen scans in children has been reported by Winter et al. (44). These authors performed 68 liver and spleen scans on 64 children (36 males, 28 females) aged 4 days to 14 years (mean, 5.5 years). Faint radioactivity concentration was seen on scans of the lungs of 16 of the 36 children (8 males and 8 females) found to be normal, for a 44% incidence; it was not seen on scans of 20 of the 36 children (13 males and 7 females). Lung radioactivity was seen in 16 of the remaining 28 children (8 males, 8 females) (57%). Radioactivity localization in the lungs was not seen in a normal child older than 11 years of age. No confirmed mechanism accounting for such lung radioactivity is known. According to Winter et al., therefore, visible radioactivity in the lungs of children during liver and spleen scanning should not be considered abnormal.

Holland et al. (45) evaluated regional distribution of pulmonary ventilation and perfusion with ^{133}Xe in 6 normal men aged 65–75. Blood flow per unit of lung volume in the upper lung zone was increased in older subjects compared with that in younger subjects. Overall distribution of perfusion increased from the apex to the base of the lung. Distribution of ventilation depended critically on the lung volume maintained during the study. In tests performed in the resting tidal volume range, ventilation was distributed primarily to the upper zones of the lung, whereas during a vital capacity inspiration, the normal distribution of ventilation favored the lower zones. That effect of lung volume is attributed to airway closure in the lower zones occurring at relatively high lung volumes in their elderly subjects. Such airway closure may be due to the combined effect of loss of elastic recoil and a decreased resistance to airway collapse associated with normal aging.

Lung perfusion defects can be encountered in a "normal" population. Tetelman et al. (46) reported that 10 of 61 clinically asymptomatic adults with normal chest roentgenograms and with no history of pulmonary disease exhibited some type of perfusion defect after receiving

Table 16.6.

Normal Variant Causes of False Positive Lung Perfusion Scan

Obesity
Large breasts
Deformed chest cage
Arm-scapula interposition
Azygos lobe

^{99m}Tc-labeled human albumin microspheres. Six of the 10 subjects exhibited subtle perfusion defects on the anterior view only: 5 with defect in the right subapical region and 1 with defect in the left. Such ill-defined minor defects are considered to be of no clinical significance and to constitute normal variants. They should not be confused with embolic disease. Although the cause of such subtle defects is unknown, they may represent minor segmental perfusion defects.

On perfusion lung images, the posterior image may reveal decreased perfusion at both costophrenic angles (i.e., "rounded" costophrenic angles). This is a normal variant caused by hypoventilation and is seen most often in obese patients (47). In such cases, right and left lateral images appear normal.

Certain anatomic variants can yield a false positive lung perfusion scan. Some of these variants are listed in Table 16.6.

An azygos fissure is reported to be seen in 0.4–1.05% of chest roentgenograms (48, 49). The fissure arises from a downward invagination of the apical portion of the right upper lobe of the lung by an anomalous azygos vein which, with its mesenteriole and fold of parietal pleura, loops away from its normal position against the chest wall and vertebrae (50). Patients with an azygos lobe may show superimposed diminished perfusion and ventilation in the medial aspect of the right upper lobe by routine nuclear medicine imaging procedures (51). That anomaly is yet another cause of subsegmental perfusion defect not caused by pulmonary embolism. The presence of an azygos lobe is considered to have no pathologic significance.

ABDOMEN AND GROIN

¹¹¹In-labeled autologous leukocytes are employed for imaging occult inflammatory proc-

esses. Repeated imaging procedures of this type in a 13-year-old girl with cystic fibrosis invariably revealed right lower quadrant radioactivity in the absence of any abdominal or pelvic abnormality (52). Marked ¹¹¹In uptake in the lung was seen and was believed to represent leukocytes in pooled secretions within bronchiectatic areas. (A similar finding in a patient of ours is shown in Figure 16.8.) Since sputum and stool samples revealed significant ¹¹¹In radioactivity, it was concluded that the abdominal activity was apparently due to swallowed sputum containing radiolabeled leukocytes.

Two anatomic variants can simulate a Meckel's diverticulum during evaluation with ^{99m}Tc-pertechnetate. First, a ureteral or duodenal diverticulum can hold radioactivity in a "pocket." Second, an extrarenal pelvis on the right kidney can be mistaken for a Meckel's diverticulum. The use of lateral views during the imaging study can elucidate such potentially false positive results.

A bone-imaging radiopharmaceutical showed marked uptake in the region of the head of the penis (53). The degree and pattern of activity suggested that long-standing phimosis and redundant foreskin resulted in a persistent collection of radioactive urine in the skin folds. It may, however, have represented activity in the genital organs due to high vascularity.

Rao and Lieberman (54) reported on the layering of radioactive bile on nonradioactive bile within the gallbladder shortly after the beginning of either ^{99m}Tc-pyridoxylidene glutamate or ^{99m}Tc-iprofenin (PIPIDA) hepatobiliary imaging. Such nonmiscibility of gallbladder contents 60–90 minutes postinjection may produce multiple intraluminal filling defects (i.e., within the gallbladder) on image. Delayed imaging (at 6 hours), which revealed the entire gallbladder filled homogeneously with radioactive bile, should indicate the true anatomic condition of the gallbladder and avoid image misinterpretation.

TOTAL BODY

Variations in [⁶⁷Ga]gallium citrate uptake are often substantial. In the head and neck, normal uptake occurs in the nasopharynx, lacrimal glands (usually bilateral but occasionally unilateral), and salivary glands.

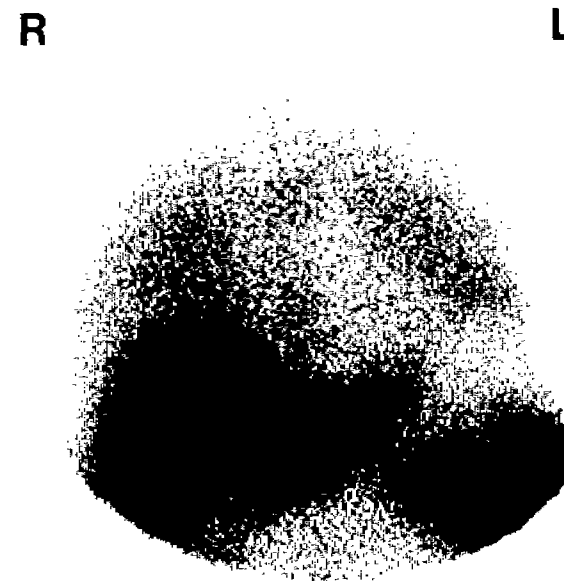

Figure 16.8. Anterior image of chest and upper abdomen at 48 hours following the injection of ¹¹¹In-labeled autologous leukocytes shows significant activities retained in both lungs. Chest radiographs were normal.

[⁶⁷Ga]gallium citrate rarely may be secreted into the stomach where it may be incorrectly interpreted as indicating tumor or abscess (55). After the patient has drunk water and a short interval is allowed to elapse, intraluminal [⁶⁷Ga]gallium citrate is washed into the intestine.

EPILOGUE

Sequestrational Inspiration*

The spleen may be one, two, or many.
Some people don't even have any.
Good for red cell accretion.
Best seen with technetium.
The size and shape do vary plenty.

One can't depend on the location.
Or quantify accumulation.
This defect's malignant,
And that one's benignant.
Now just what does one tell the patient?

Letty G. Lutzker (56)

* Adapted and reproduced with permission from: L. G. Lutzker and the *Journal of Nuclear Medicine* (56).

REFERENCES

- Keats TE: Normal anatomic variants and artifacts that may simulate disease. In Resnick D, Niwayama G (eds): *Diagnosis of Bone and Joint Disorders with Emphasis on Articular Abnormalities*. Philadelphia, WB Saunders, 1981, vol 1, pp 704–736.
- DeLand FH, North WA: Relationship between liver size and body size. *Radiology* 91:1195–1198, 1968.
- Johnson RJ: Anatomy of the liver. In Rothfield B (ed): *Nuclear Medicine: Hepatobiliary*. Philadelphia, JB Lippincott, 1980, pp 8–11.
- Caroli J, Bonneville B: Valeur diagnostique de la scintillographie hépatique. *Arch Mal Appar Dig* 51:55–82, 1962.
- Sham R, Sain A, Silver L: Hypertrophic Riedel's lobe of the liver. *Clin Nucl Med* 3:79–81, 1978.
- Mayle JE, Caldwell JH: False positive liver scan due to a thin left hepatic lobe. *J Clin Gastroenterol* 2:165–167, 1980.
- Park CH, Mansfield CM: Pseudodeflect in ^{99m}Tc-sulfur colloid liver scan caused by hepatodiaphragmatic interposition. *J Natl Med Assoc* 67:126–127, 1975.
- DeLand FH, Wagner HN Jr: *Atlas of Nuclear Medicine*, vol 3: *Reticuloendothelial System, Liver, Spleen, and Thyroid*. Philadelphia, WB Saunders, 1972, p 217.
- Wescott JL, Drufky EL: The upside-down spleen. *Radiology* 105:517–521, 1972.
- Simpson AJ, Salzman AJ, Astin JK: Inversion of the spleen-scintigraphic features. Letter to the editor. *J Nucl Med* 18:1145–1146, 1977.
- Mahin D, Wagner HN Jr: Brain—the value of brain

- scans in pediatrics. In James AE Jr, Wagner HN Jr, Cooke RE (eds): *Pediatric Nuclear Medicine*. Philadelphia, WB Saunders, 1974, pp 103-115.
12. Holmes RA, Golle R: Appearance of the transverse sinuses by brain scanning. *AJR* 106:340-343, 1969.
 13. Conway JJ, Quinn JL III: Brain imaging in pediatrics. In James AE Jr, Wagner HN Jr, Cooke RE: *Pediatric Nuclear Medicine*. Philadelphia, WB Saunders, 1974, pp 115-126.
 14. Meyer JS, Ishihara N, Deshmukh VD, et al: Improved method for noninvasive measurement of regional cerebral blood flow by xenon inhalation. Part I. Description of method and normal values obtained in healthy volunteers. *Stroke* 9:195-205, 1978.
 15. Deshmukh VD, Meyer JS: *Noninvasive Measurement of Regional Cerebral Blood Flow in Man*. New York, Spectrum Publications, 1978, p 144.
 16. Silberstein EB: Causes of abnormalities reported in nuclear medicine testing. *J Nucl Med* 17:229-232, 1976.
 17. Fogelman I, Bessent RG, Gordon D: A critical assessment of bone scan quantitation (bone to soft tissue ratios) in the diagnosis of metabolic bone disease. *Eur J Nucl Med* 6:93-97, 1981.
 18. Hosain P: Technetium-99m labeled pyrophosphate: a simple and reproducible bone scanning agent. *Br J Radiol* 46:724-728, 1973.
 19. Wilson MA: The effect of age on the quality of bone scans using technetium-99m pyrophosphate. *Radiology* 139:703-705, 1981.
 20. Coupal JJ, Domstad PA, DeLand FH: Influence of patient age upon Tc-99m-oxidronate (Tc-HMDP) bone image (abstract). *Clin Nucl Med* 6:P158, 1981.
 21. Alazraki N: Bone imaging by radionuclide technique. In Resnick D, Niwayama G: *Diagnosis of Bone and Joint Disorders with Emphasis on Articular Abnormalities*. Philadelphia, WB Saunders, 1981, vol 1, pp 639-678.
 22. Silberstein EB, Francis MD, Tofe AJ, et al: Distribution of 99mTc-Sn diphosphonate and free 99mTc-pertechnetate in selected soft and hard tissues. *J Nucl Med* 16:58-61, 1975.
 23. Oppenheim BE, Cantez S: What causes lower neck uptake in bone scans? *Radiology* 124:749-752, 1977.
 24. Heck LL: Extra-osseous localization of phosphate bone agents. *Semin Nucl Med* 10:311-313, 1980.
 25. DeLand FH, Wagner HN Jr: *Atlas of Nuclear Medicine*, vol 3: *Reticuloendothelial System, Liver, Spleen and Thyroid*. Philadelphia, WB Saunders, 1972, pp 246-247.
 26. Lunia S, Chodos RB, Heravi M, et al: False-positive pertechnetate thyroid scintigram. *Clin Nucl Med* 3:48, 1978.
 27. Rajguru HL, Poulouse KP, Reba RC: Esophageal tracer retention simulating substernal goiter (letter to the editor). *J Nucl Med* 18:404, 1977.
 28. Wells LD, Bernier DR: *Radionuclide Imaging Artifacts*. Chicago, Year Book Medical Publishers, 1980, p 100.
 29. Tyson JW, Wilkinson RH Jr, Witherspoon LR, et al: False-positive 131I total-body scans. Case report. *J Nucl Med* 15:1052-1053, 1974.
 30. Rumble WF, Aamodt RL, Jones AE, et al: Accidental ingestion of ^{99m}Tc in breast milk by a 10-week-old child. Case report. *J Nucl Med* 19:913-915, 1978.
 31. Vagenakis AG, Abreau CM, Braverman LE: Duration of radioactivity in the milk of a nursing mother following ^{99m}Tc administration. *J Nucl Med* 12:188, 1971.
 32. Larson SM, Schall GL: Gallium-67 concentration in human breast milk. *JAMA* 218:257, 1971.
 33. Tobin RE, Schneider PB: Uptake of ⁶⁷Ga in the lactating breast and its persistence in milk. Case report. *J Nucl Med* 17:1055-1056, 1976.
 34. Ogunleye OT: Assessment of radiation dose to infants from breast milk following the administration of ^{99m}Tc-pertechnetate to nursing mothers. *Health Phys* 45:149-151, 1983.
 35. MacDonald MS, Emery JL: The late intrauterine and postnatal development of human renal glomeruli. *J Anat* 93:331-341, 1959.
 36. Potter EL: Development of the human glomerulus. *Arch Pathol* 80:241-255, 1965.
 37. West JR, Smith HW, Chasis H: Glomerular filtration rate, effective renal blood flow, and maximal tubular excretory capacity in infancy. *J Pediatr* 32:10-18, 1948.
 38. Calcagno PL, Rubin MI: Renal extraction of para-amino-hippurate in infants and children. *J Clin Invest* 42:1632-1639, 1963.
 39. Bell EG, McAfee JG, Subramanian G: Radiopharmaceuticals in pediatrics. In James AE Jr, Wagner HN Jr, Cooke RE (eds): *Pediatric Nuclear Medicine*. Philadelphia, WB Saunders, 1974, pp 84-94.
 40. Older RA, Korobkin M, Workman J, et al: Accuracy of radionuclide imaging in distinguishing renal masses from normal variants. *Radiology* 136:443-448, 1980.
 41. Rao GM, Nagesh KG, Guruprakash GH: Position-related false-positive renal imaging. *Clin Nucl Med* 5:318-319, 1980.
 42. Botvinick EH, Dunn RF, Hattner RS, et al: A consideration of factors affecting the diagnostic accuracy of thallium-201 myocardial perfusion scintigraphy detecting coronary artery disease. *Semin Nucl Med* 10:157-167, 1980.
 43. Fetz RC, Stadalnik RC, Matin P: Myocardial "false positive" ^{99m}Tc-pyrophosphate scintigrams. *Semin Nucl Med* 11:64-65, 1981.
 44. Winter PF, Peri LJ, Johnson PM: Lung uptake of colloid during liver-spleen scanning: a normal finding in children. *Nuklearmedizin* 15:294-296, 1976.
 45. Holland J, Milic-Emili J, Macklem PT, et al: Regional distribution of pulmonary ventilation and perfusion in elderly subjects. *J Clin Invest* 47:81-92, 1968.
 46. Tetelman MR, Hoffer PB, Heck LL, et al: Perfusion lung scan in normal volunteers. *Radiology* 106:593-594, 1973.
 47. DeLand FH, Wagner HN Jr: *Atlas of Nuclear Medicine*, vol 2: *Lung and Heart*. Philadelphia, WB Saunders, 1970, pp 34-35.
 48. Felson B: The lobes and interlobar pleura: fundamental roentgen considerations. *Am J Med Sci* 230:572-584, 1955.
 49. Pendley WO: The azygos lobe in photofluorography. *US Naval Med Bull* 46:1920-1927, 1946.
 50. Anson BJ, Siekert RG, Richmond TE, et al: The accessory pulmonary lobe of the azygos vein. *Q Bull Northwestern Univ Med School* 24:285-290, 1950.
 51. Polga JP, Drum DE: Abnormal perfusion and ventilation scintigrams in patients with azygos fissures. Case report. *J Nucl Med* 13:633-636, 1972.
 52. Crass JR, L'Heureux P, Loken M: False-positive ¹¹¹In-labeled leukocyte scan in cystic fibrosis. *Clin Nucl Med* 4:291-293, 1979.
 53. Glassman AB, Selby JB: Another bone imaging agent false-positive: phimosis. *Clin Nucl Med* 5:34, 1980.
 54. Rao BK, Lieberman LM: Bile layering: a cause for false-positive cholescintiscans. *AJR* 134:1251-1253, 1980.
 55. Wahner HW, Brown ML, Dickson ER: Gallium accumulation in the stomach: a false-positive scan suggesting abscess, (letter to the editor). *J Nucl Med* 20:577-578, 1979.
 56. Lutzker LG: Sequestrational inspiration. *J Nucl Med* 17:944, 1976.

17

Unusual or Unanticipated Alterations in the Biodistribution of Radiopharmaceuticals as a Result of Pathologic Mechanisms

E. Edmund Kim and John J. Coupal

RADIOPHARMACEUTICALS FOR CENTRAL NERVOUS SYSTEM IMAGING

Radionuclide Brain Imaging

In imaging of the normal brain with sodium [^{99m}Tc]pertechnetate, ^{99m}Tc -diethylenetriaminepentaacetic acid (DTPA), or ^{99m}Tc -glucoptate (GH),* the cerebral hemispheres appear symmetrical and nearly free of radioactivity. These radionuclides concentrate within and around brain lesions because of local tissue and vascular alterations. Leveille et al. (1) have suggested that the accumulation of ^{99m}Tc -GH in brain tumor (Fig. 17.1) may occur by active transport in the form of a glucose analog in metabolically active neoplastic cells. Very well differentiated astrocytomas, grades I and II, may give negative brain images, possibly due to little or no breakdown of the blood-brain barrier (2).

Brain imaging with ^{99m}Tc -GH occasionally demonstrates multifocal cerebral lesions of acute lymphocytic leukemia (3). There has been a report of multiple myeloma involving the skull that demonstrated increased activity on brain imaging with ^{99m}Tc -pertechnetate.† Bone imag-

ing with ^{99m}Tc -pyrophosphate showed increased activity in the same area in one patient and decreased activity in the other (4). Metastatic intracranial neuroblastoma was detected in a child undergoing bone scintigraphy with ^{99m}Tc -methylene diphosphonate (MDP) (5).

The most common intracranial cysts, porencephaly, generally produce no abnormalities on the static brain images. Leptomeningeal cysts may, however, produce increased peripheral activity that simulates a chronic subdural hematoma. The "ring or doughnut" sign on the brain image is commonly associated with cerebral tumor, hematoma, infarction, and abscess. It has, however, rarely been seen in adrenoleukodystrophy, sebaceous cyst, and metastatic Wilms' tumor (6–8).

The static brain images do not become positive before 7–10 days following the stroke. Occasionally, increased perfusion about some infarction during the early phases of the radionuclide angiogram is observed in the "hot stroke" (9). Focal radionuclide brain imaging abnormalities may rarely appear after seizure in patients with prolonged idiopathic epilepsy (10). Visualization of cerebral ventricles during brain imaging has been unusually associated with intraventricular hemorrhage, anoxia, and chemotherapeutic neurotoxicity (11–13).

Radionuclide Cisternogram

The changes in the cisternographic pattern obtained with use of ^{111}In - or ^{169}Yb -labeled DTPA in patients with hydrocephalus are asso-

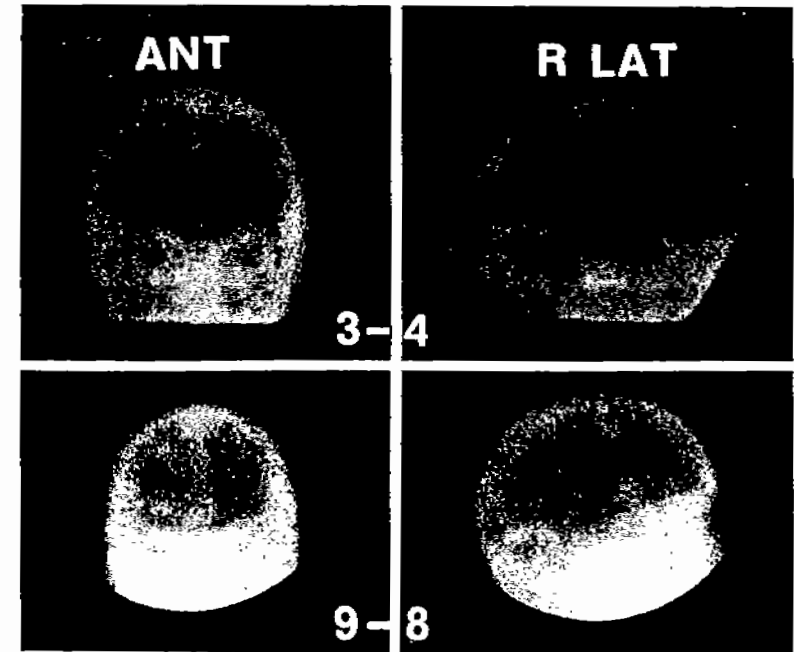

Figure 17.1. Selective anterior (ANT) and right lateral (R LAT) views of the static brain images obtained with use of ^{99m}Tc -GH show two metastatic melanomas in the right frontal lobe which were developed 6 months later.

ciated with the presence or the absence of ventricular reflux and the relative rate of cerebral spinal fluid (CSF) clearance. If the mechanical block is higher over the convexity of the CSF space, a combination pattern is seen, i.e., ventricular reflux and variably delayed flow over the convexities (14), depending on the degree of compensation. With normal pressure hydrocephalus (Fig. 17.2), there is usually persistent activity refluxed into the lateral ventricles. The most common pattern of cerebral atrophy is delayed migration of the radioactivity with or without various convexity blocks and without ventricular reflux. Often the pattern may be normal, however, and transient ventricular reflux usually does not persist at 24 hours (15).

RADIOPHARMACEUTICALS FOR THYROID IMAGING

The pertechnetate ion is trapped by the same mechanisms that trap the iodide ion, and all conditions that interfere with iodide trapping

also interfere with the trapping of pertechnetate which is not organified. The reported discrepant images obtained with the use of radioiodine and sodium [^{99m}Tc]pertechnetate were from certain patients with chronic thyroiditis, benign nodules, or malignant nodules (16). There was a report of an unusual selective accumulation of ^{99m}Tc in the thyroid during in vivo labeling of red blood cells (RBC) for gated blood pool imaging; this accumulation could not be satisfactorily explained (17).

A cold nodule (Fig. 17.3) on thyroid imaging is commonly associated with adenoma, colloid cyst, and carcinoma. Rare causes of a cold thyroid nodule include lymphoma, paragangliomatosis, and arteriovenous fistula (18–20). Most malignant thyroid nodules are photopenic due to poor radioactive uptake relative to normal thyroid tissue, but there has been a report of imaging of primary thyroid carcinoma with ^{131}I (21). Ryo et al. (22) recently noted areas of extra-thyroidal uptake on thyroid scans obtained with

* Glucoptate is the official (USAN) name for what was previously known as glucoheptonate; the commonly used abbreviation "GH" comes from this latter term.

† Although [^{99m}Tc]pertechnetate and [^{67}Ga]gallium citrate are preferred by IUPAC, ^{99m}Tc -pertechnetate and ^{67}Ga -citrate are standard, and both are used throughout this chapter.

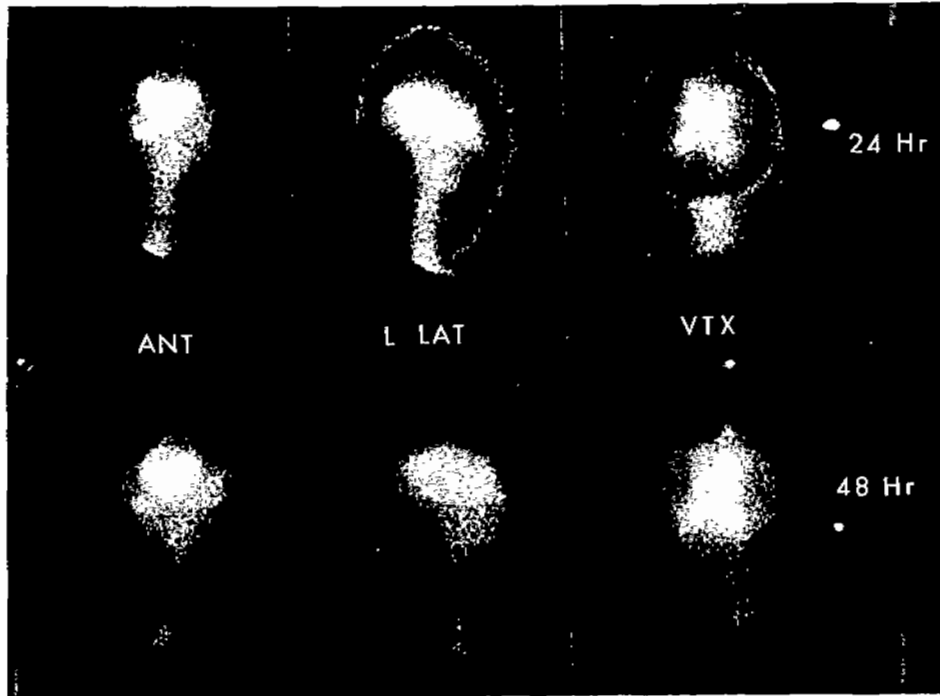

Figure 17.2. Anterior (ANT), left lateral (L LAT), and vertex (VTX) views of the head at 24 and 48 hours following the injection of ^{111}In -DTPA show persistent activity refluxed into lateral ventricles, consistent with normal pressure hydrocephalus.

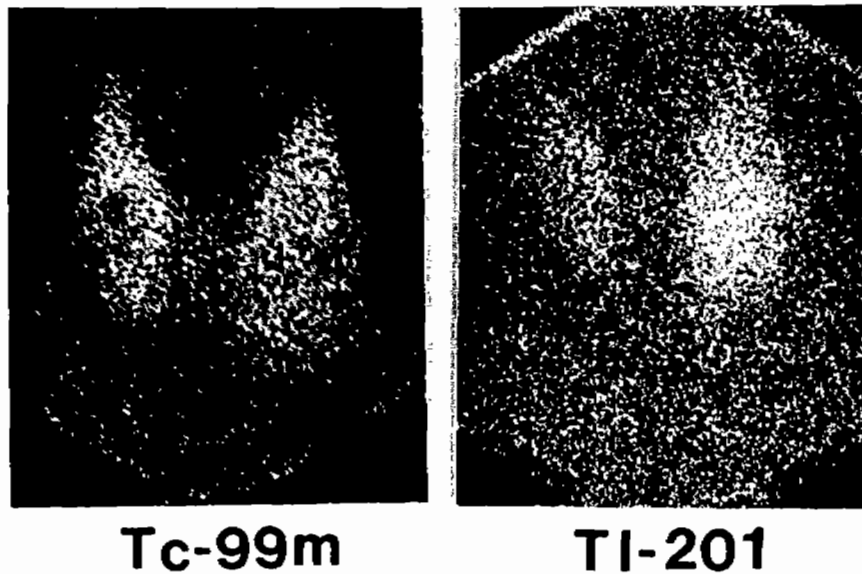

Figure 17.3. Anterior thyroid image with $^{99\text{m}}\text{Tc}$ -pertechnetate shows cold nodules in right and left lobes which concentrate ^{201}Tl . At surgery thyroid adenomas were found.

RADIOPHARMACEUTICALS FOR CARDIOVASCULAR IMAGING

Radionuclide Cardiac Imaging

use of $^{99\text{m}}\text{Tc}$ and ^{123}I in four patients with follicular thyroid carcinoma, and all palpable nodes containing metastatic carcinoma showed radionuclide uptake. A patient with medullary carcinoma of the thyroid and lymph node metastases was noted to show uptake of radiopertechnetate, radioiodine, and radiothallium. A perchlorate test was positive which indicated that the uptake was largely due to trapping (23). There has been a report also of the rare occurrence of a carcinoma within autonomous hyperactive (hot) thyroid nodules (24). We observed ^{131}I uptake in a proven ovarian cyst (Fig. 17.4).

Breast uptake of ^{123}I has been reported in a young primipara with postpartum transient thyrotoxicosis (25). Follow-up imaging with ^{123}I after treatment with propylthiouracil showed no further breast uptake. In two cases of subacute thyroiditis, increased activity in the affected areas, shown as cold areas on the $^{99\text{m}}\text{Tc}$ scans, was observed on ^{201}Tl scans (26).

Studies in which a focal defect on ^{201}Tl images can be seen in a patient at rest are suggestive of myocardial infarction. Hypertrophy of the papillary muscle of the left ventricle rarely was visualized as a defect on ^{201}Tl images as well as on gated blood pool images (27). Right atrial enlargement on $^{99\text{m}}\text{Tc}$ -labeled RBC or human serum albumin (HSA) cardiac imaging has, uncommonly, resulted from right ventricular infarction, pulmonary stenosis, and tricuspid or mitral stenosis or regurgitation (28).

Paradoxical motion of the interventricular septum on radionuclide ventriculogram occasionally has been seen in right ventricular tumor, pulmonary stenosis, and constrictive pericarditis (29–31). A left-to-right shunt detected from the curve analysis of pulmonary time-ac-

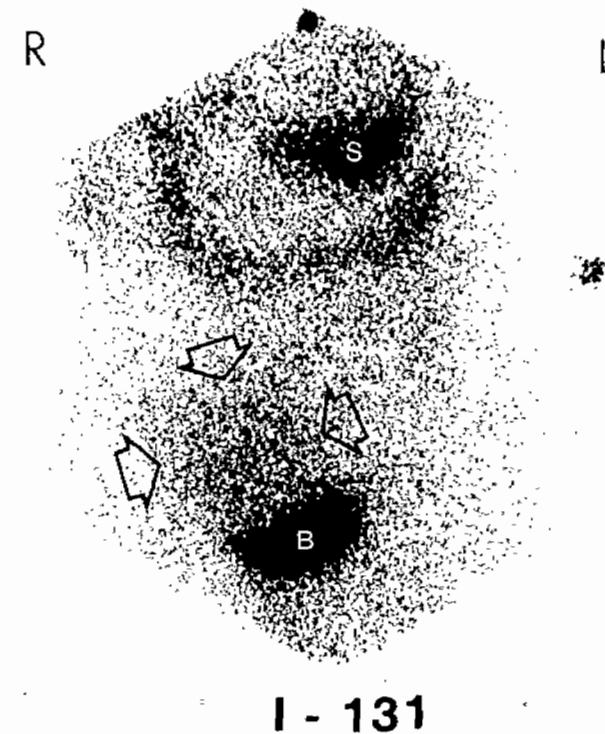

Figure 17.4. Anterior abdominal image at 24 hours following the administration of ^{131}I shows radioiodine uptake in surgically proven ovarian cyst. S, stomach; B, bladder.

tivity has been less commonly associated with cerebral arteriovenous fistula and rarely associated with a right pulmonary artery originated from the aorta (32–33).

Documented transmural infarctions appear to result in abnormal uptake of ^{99m}Tc -pyrophosphate, gluceptate, or tetracycline in more than 90% of the patients (34). A false positive myocardial scintigram obtained with use of ^{99m}Tc -pyrophosphate has been uncommonly associated with cardiomyopathy and rarely observed in patients with secondary hyperparathyroidism, pericarditis, chronic myocarditis (Chagas' disease), metastatic tumor to the heart, and calcified costal cartilages (34–38). Intense myocardial uptake on a ^{99m}Tc -MDP bone scan also was demonstrated in a patient with hypercalcemia or amyloidosis of unknown mechanism (39, 40).

Radionuclide Vascular Imaging

Superior vena cava obstruction imaged with ^{99m}Tc -labeled sulfur colloid (SC) or macroag-

gregated albumin (MAA) often shows collateral venous pathways along the chest wall and is commonly associated with lung cancer and lymphoma. It has been rarely associated with thrombophlebitis, atrial myxoma, neuroblastoma, and leukemia (41). Infusion of ^{99m}Tc -MAA into the hepatic artery catheter has been utilized for monitoring of catheter position and tumor perfusion. Lung uptake of the MAA due to arteriovenous (AV) shunt at the tumor bed (Fig. 17.5) may be useful in prediction of the therapeutic response of hepatic tumor.

RADIOPHARMACEUTICALS FOR LUNG IMAGING

^{133}Xe ventilation and ^{99m}Tc -labeled human albumin microsphere (HAM) perfusion \dot{V}/\dot{Q} mismatch unassociated with pulmonary embolism has been rarely found in intrathoracic stomach (Fig. 17.6, A and B), pulmonary artery sarcoma, hemangioendotheliomatosis, and lymphangitis carcinomatosa (42–44). There

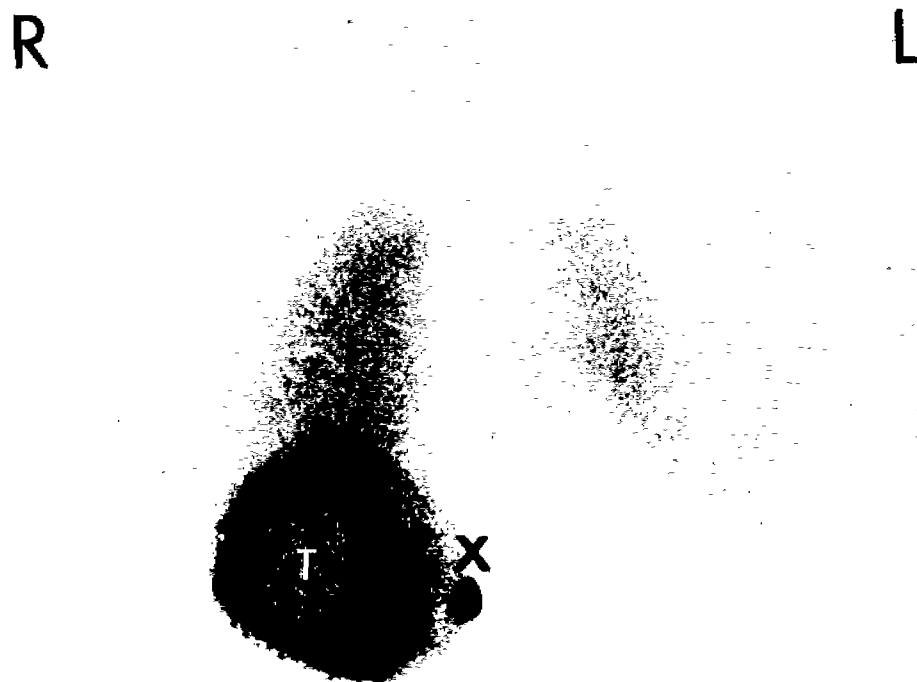

Figure 17.5. Anterior image of the chest and upper abdomen after infusion of ^{99m}Tc -MAA shows significant activities in both lungs due to AV shunt at the tumor bed (T). X denotes marker on xiphoid process.

was a case of pulmonary venous obstruction producing \dot{V}/\dot{Q} mismatch due to stagnating blood flow reflected by a delayed intense capil-

lary phase in that lobe and late opacification of the corresponding draining vein (45). \dot{V}/\dot{Q} mismatch was also reported to be due to aber-

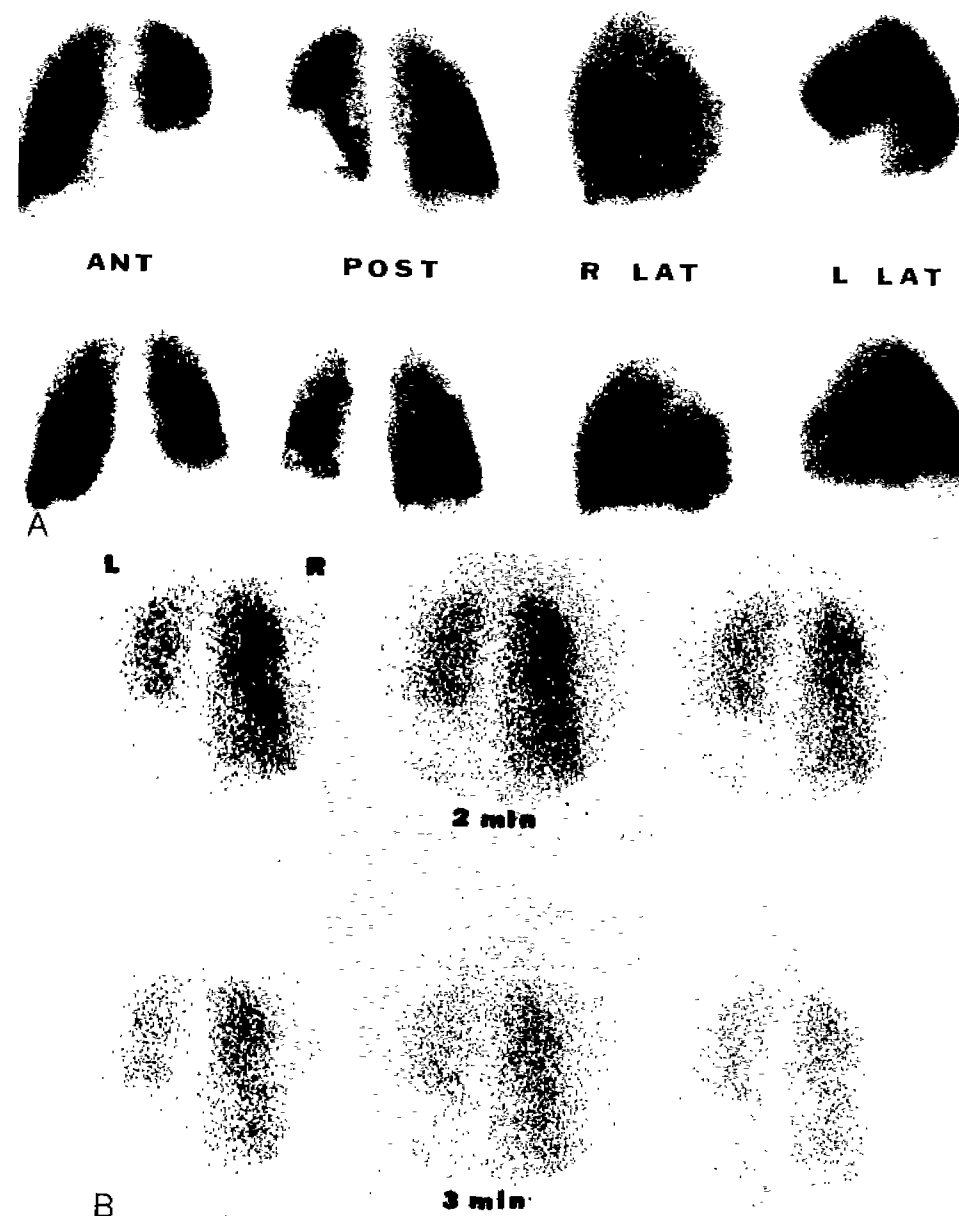

Figure 17.6. A. Multiple lung images with ^{99m}Tc -HAM show sharply outlined perfusion defect in the right lower lobe preoperatively (upper row) due to herniated stomach. Postoperative images are in the lower row. B. Preoperative ventilation study after ^{133}Xe gas inhalation shows markedly elevated left hemidiaphragm and minimal diffuse obstructive airway disease.

rant arterial supply from a systemic vessel rather than from pulmonary circulation (45). The presence of ^{99m}Tc -HAM in areas other than lung suggests the presence of a right-to-left shunt. Eisenmenger physiology may be shown with reversal of a left-to-right shunt following the development of severe pulmonary hypertension.

Myocardial activity was visualized on a perfusion lung scan in a patient with primary pulmonary hypertension and a right-to-left shunt through a foramen ovale (47). There was a report of marked retention of ^{133}Xe by the skeletal structure (largely in the intraosseous fat), probably associated with the patient's prolonged steroid therapy that alters systemic lipid metabolism by increasing the quantity of intracellular lipid synthesizing enzyme (48). Pulmonary hydatid cyst evidenced by a ^{67}Ga gallium citrate scan that showed an oval area of homogeneous uptake has been reported (49).

RADIOPHARMACEUTICALS FOR GASTROINTESTINAL IMAGING

Focal increased radioactive uptake in the salivary gland is commonly associated with Warthin's tumor, probably due to secreting ^{99m}Tc -pertechnetate not being excreted as quickly as the saliva. An oxyphilic adenoma has been reported to show these same findings (50). Focal "hot" spots on the colloidal liver scan usually have been associated with superior vena caval or hepatic vein obstruction. There have been reports, however, of hot spots on the liver scan due to inferior vena caval obstruction, isolated innominate vein obstruction, and tricuspid insufficiency (51–53). Hemangioma, hamartoma, and abscess have been reported to cause a focal area of increased uptake of radiolabeled SC, probably due to increased local vascularity (54–56). There was a case of primary hepatocellular carcinoma appearing as a defect on a

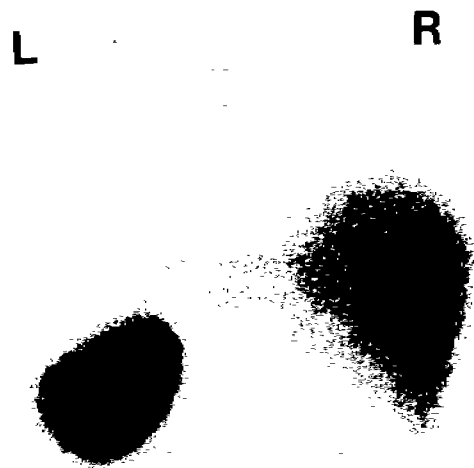

Figure 17.7. Posterior image of the upper abdomen with ^{99m}Tc -labeled sulfur colloid in a patient with melanoma shows no focal defect but a hot spleen.

SC liver scan and visualized on a hepatobiliary scan obtained with use of ^{99m}Tc -pyridoxylidene glutamate (57). Absence of hepatic uptake of ^{99m}Tc -labeled SC in an infant with Coxsackie B₂ viral infection has been described and may be associated with marked impairment of Kupffer cell function in the liver (58).

Usually, nonvisualization of the gallbladder on cholescintigraphy is due to obstructive cholecystitis, but an adenocarcinoma of the cystic duct has been reported to show these same findings (59). There has been a report of a patient who had clinical and pathologic findings of acute cholecystitis but normal visualization. This situation may occur in patients with recent relief of cystic duct obstruction but persistence of the acute inflammatory response (60). Metastatic pulmonary nodules from a well-differentiated hepatoma were demonstrated by ^{99m}Tc -paraisopropyl iminodiacetic acid (PIPIDA) with unknown mechanism (61).

Focal splenic defect often has been associated with infarctions and rarely has resulted from splenic arteriovenous malformation and amyloidosis (62). Functional asplenia (anatomic presence of the spleen but without the ability to accumulate intravenously administered radiocolloid) has been unexpectedly noted in Sézary syndrome (a lymphoma of cutaneous origin) (63) and chronic aggressive hepatitis (64). There was a report that the spleen in a patient with Sézary syndrome could not be visualized with use of a ^{99m}Tc -labeled tin colloid (SnC) but was visualized with use of a ^{99m}Tc -SC, although the same reticuloendothelial system (RES) is involved in the phagocytosis of both radiopharmaceuticals (65). A "hot" spleen on the ^{99m}Tc -SC scan (Fig. 17.7) has been described in patients with melanoma and may be associated with increased phagocytosis secondary to the unique antigenicity of the tumor (66).

Diffuse lung uptake of ^{99m}Tc -SC has been

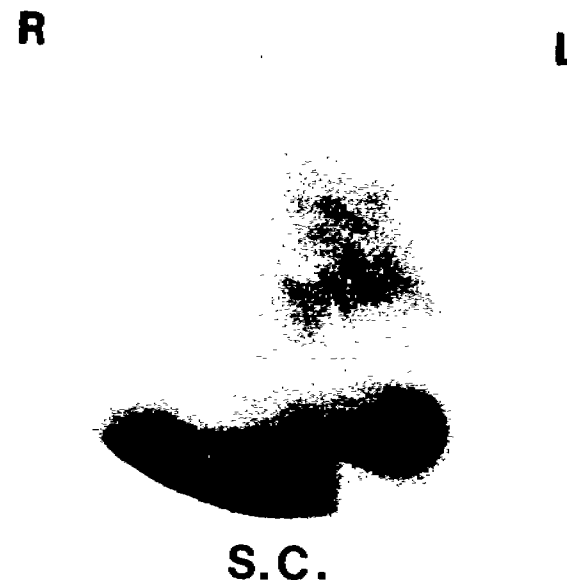

Figure 17.8. Anterior image of the chest during the liver-spleen scan shows marked uptake of sulfur colloid (S.C.) in the left lung. There were pleural effusions bilaterally. Liver and spleen images were negative.

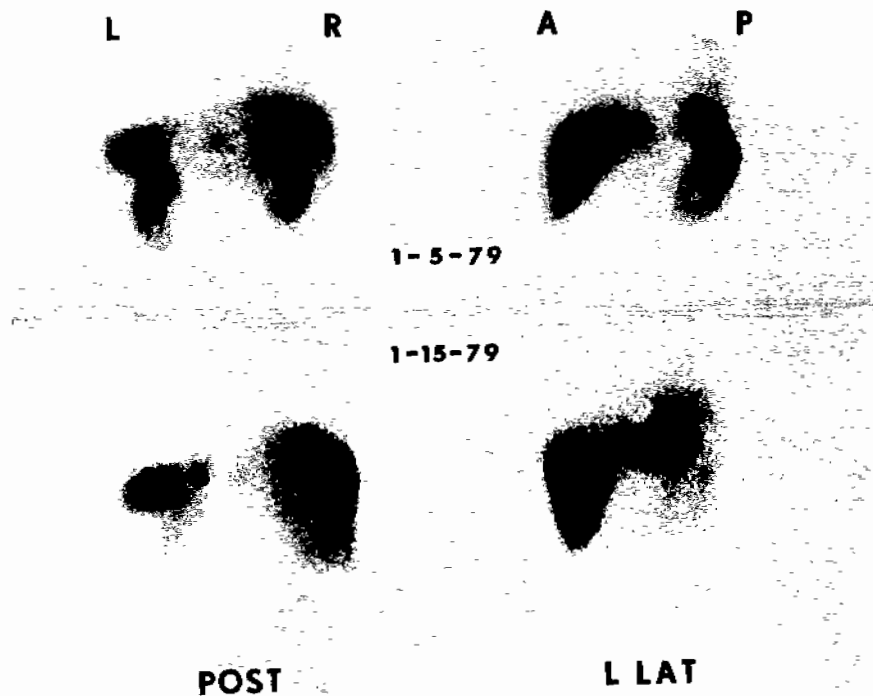

Figure 17.9. Posterior (*POST*) and left lateral (*L LAT*) images of the upper abdomen with ^{99m}Tc-labeled sulfur colloid show marked renal uptake of radioactivity in a patient with congestive heart failure. Note the significant reduction of renal activity after 10 days of treatment.

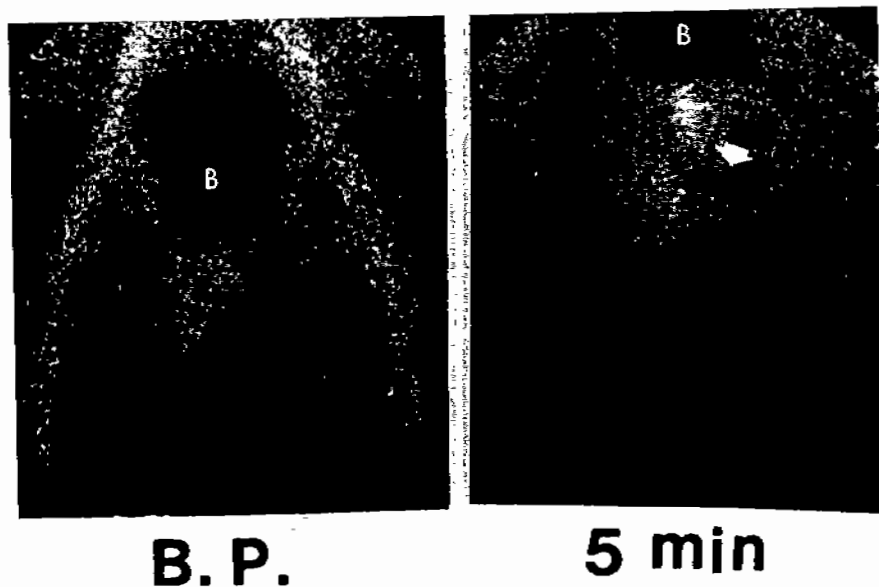

Figure 17.10. Blood pool (*B.P.*) and 5-minute static images of the scrotum show a focal lesion without calcification. A hydrocele and subacute testicular torsion were found. *B.*, bladder.

uncommonly seen in patients with histiocytosis X, organ transplantation, and amyloidosis (67, 68). ^{99m}Tc-SC was accumulated in one lung (Fig. 17.8) following blunt trauma to the chest, although the lung remained clear radiographically. The cause of this phenomenon is unclear and may be associated with fibrin deposition, inflammatory response, or delayed clearance of SC due to ipsilateral hypoventilation (69). There was a report of lung and kidney uptake of ^{99m}Tc-SC following treatment for disseminated intravascular coagulation (70). Renal uptake of ^{99m}Tc-SC (Fig. 17.9) was observed in patients with congestive heart failure (71).



Figure 17.11. Anterior and posterior whole-body images with ^{99m}Tc-diphosphonate show markedly increased activities diffusely in the long bones due to active osteoporosis.

^{99m}Tc -DTPA was found to localize in segments of bowel with inflammation due to ulcerative colitis, regional enteritis, and other forms of enterocolitis (72). Scintigraphy with ^{111}In -labeled leukocytes is a sensitive and relatively specific clinical test for detecting localized infection. Leukocytes are reported to have accumulated in an area of small-bowel ischemia or infarction and mimicked a paracolic abscess (73).

RADIOPHARMACEUTICALS FOR GENITOURINARY IMAGING

Radionuclide Renal Imaging

Splenic uptake of ^{99m}Tc -DTPA was unexpectedly observed during the performance of a diuretic renogram (74). It was postulated that this

uptake occurred secondary to a contiguous splenic inflammatory process with its concomitant increase in capillary permeability and breakdown of blood-tissue barriers. Unusual vertebral and pelvic visualization during renal dynamic study with use of ^{99m}Tc -DTPA was reported in a leukemic patient (75), probably due to blood pool visualization of bone and/or marrow. Gallbladder uptake and biliary excretion of ^{99m}Tc -GH in poor renal function have been reported (76). ^{99m}Tc -GH uptake in a breast nodule and lymphadenopathy caused by metastatic lung cancer has been described (77).

It has been recognized that a renal allograft showing neither pertechnetate nor hippurate concentration warrants surgical removal irrespective of the etiology. An exceptional case demonstrated that there may be recovery of re-

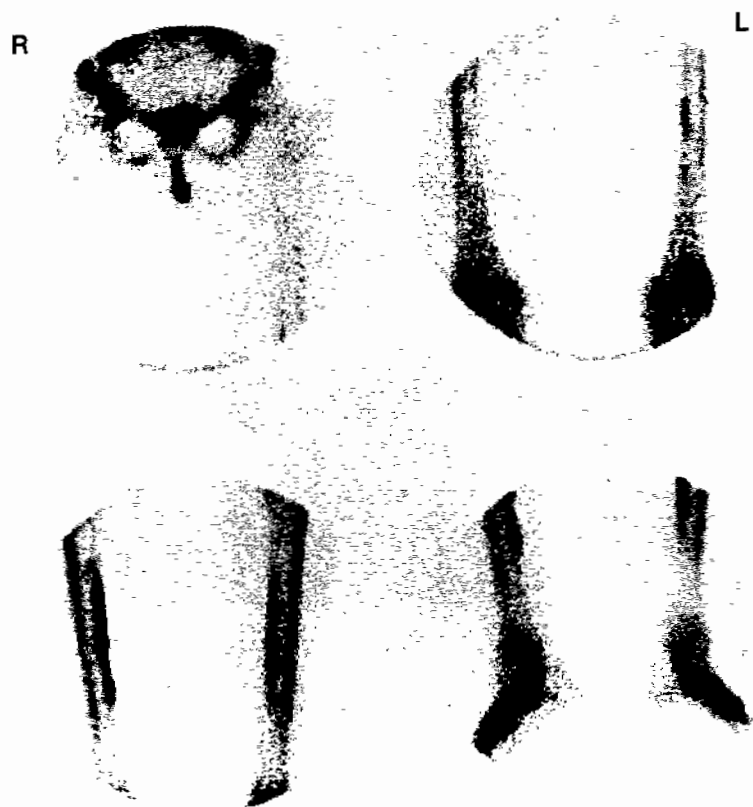

Figure 17.12. Anterior spot views of the lower extremity with ^{99m}Tc -MDP show increased activities along the cortices due to stress reaction related to heavy exercise.

nal allograft function in spite of clinical, scintigraphic, and histologic criteria suggestive of hyperacute rejection (78). There have been reports of significant uptake of ^{99m}Tc -labeled SC,

^{67}Ga -citrate, and ^{111}In -labeled leukocytes in some kidneys with chronic rejection (79). Graft scintigraphy with ^{111}In -labeled platelets seems to be useful for the diagnosis of rejection, al-

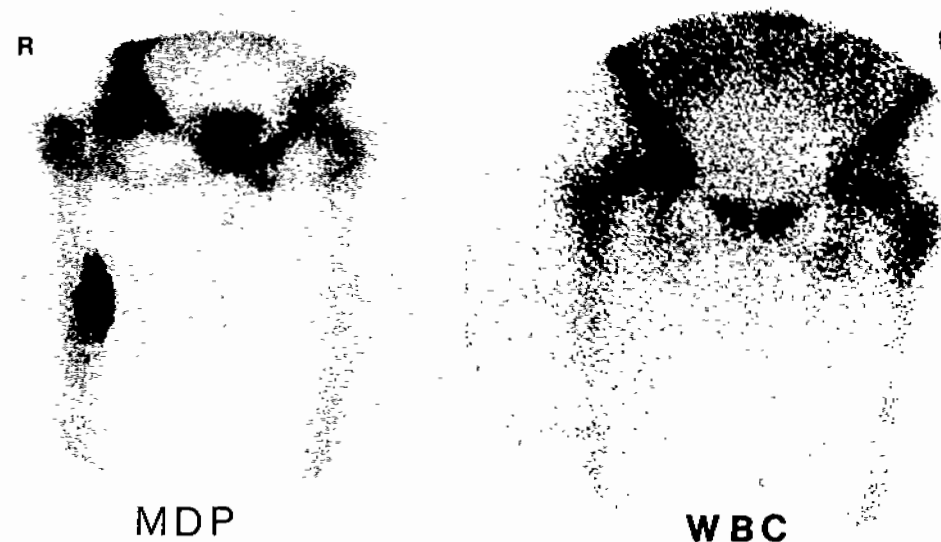

Figure 17.13. Anterior images of the upper leg with use of ^{99m}Tc -MDP and ^{111}In -labeled leukocytes show a focal lesion in the right femoral shaft. At surgery, sclerosing osteomyelitis was found.

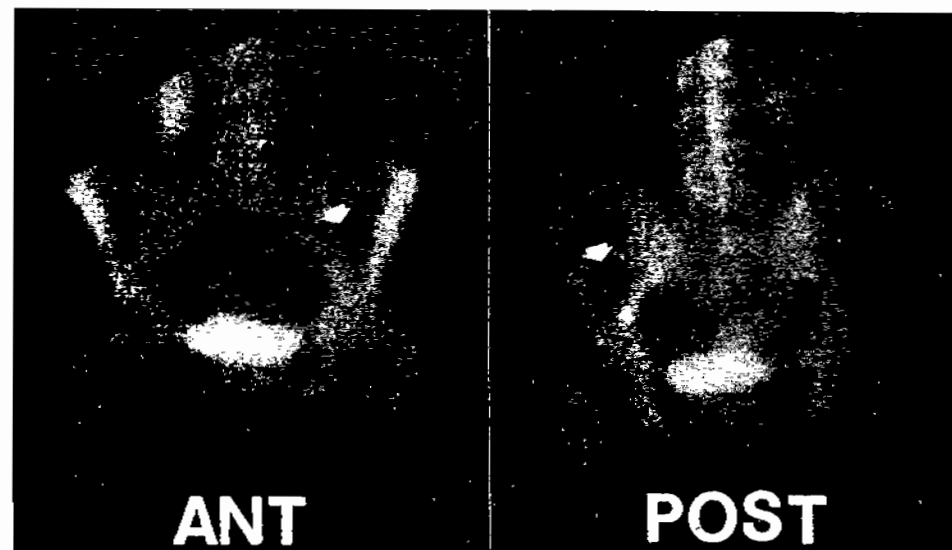

Figure 17.14. Anterior (ANT) and posterior (POST) images of the pelvis with ^{99m}Tc -MDP show a cold metastatic lesion of renal cell carcinoma (arrows).

though a false positive image due to hematoma has been described (80).

Radionuclide Adrenal Imaging

Unilateral visualization of the adrenal gland on a scan usually is due to adrenal cortical adenoma with suppressed contralateral gland and unilateral metastatic breast or lung carcinoma. Rare causes of nonvisualization of unilateral adrenal gland have included aldosterone-producing carcinoma with destruction of the unilateral gland and congenital adrenal cyst (81).

Radionuclide Testicular Imaging

Increased scrotal radioactivity usually is suggestive of epididymo-orchitis or seminoma, but a rare pheochromocytoma also showed increased activity of the scrotal contents (82). A focal defect on the scrotal image (Fig. 17.10) can be due to testicular torsion, hydrocele, hematoma, and tumor.

RADIOPHARMACEUTICALS FOR MUSCULOSKELETAL IMAGING

Radionuclide Bone Imaging

Increased activity of bone-imaging agents (Figs. 17.11, 17.12, and 17.13) is associated with bone blood flow and osteoblastic activity. Myelofibrosis usually has been presented as a hypermetabolic bone disease showing symmetrically increased activity, especially around the knee joints, possibly due to increased bone blood flow or periostitis observed on myelofibrosis (83, 84). Decreased bone uptake of ^{99m}Tc -labeled polyphosphate was seen in a patient with thalassemia major (85). In rare cases in which the bone has been replaced by aggressive malignant disease, the bone scan may be negative. "Cold" lesions (Fig. 17.14) have been reported in patients with metastatic carcinomas, osteomyelitis (86), myeloma (87), fibrosarcoma (88), and Ewing's sarcoma (89). An abdominal aortic aneurysm was demonstrated on static bone images as a photon-deficient region (90). A "cold spot" was noted in all three phases of bone scan in a patient with gas gangrene of the foot (91) and may result from destruction of blood vessels in the area of myonecrosis, with resultant absent perfusion of the

adjacent soft-tissue and bony structure. Cases of widespread thyroid metastatic disease to bone, in which there is avid accumulation of ^{131}I and no increased uptake of the ^{99m}Tc -labeled phosphate complexes, have been demonstrated.



Figure 17.15. Anterior whole-body image obtained with use of ^{99m}Tc -MDP show diffuse abnormal activities in the left chest. A malignant pleural effusion was found.

Increased accumulation of ^{99m}Tc -phosphate in pleural effusion (Fig. 17.15) or ascitic fluid associated with various neoplasms has been observed (92, 93). Unexpected uptake of ^{99m}Tc -labeled phosphate compounds has been reported without precise mechanism in certain carcinomas of breast, lung, rectum, and ovary, pancreatic islet cell tumor, neuroblastoma, Hodgkin's disease, lipoma, liposarcoma, cerebral, myocardial, and intestinal infarctions, and dermatomyositis (94–96).

Several patients with normal intravenous pyelogram showed focal increased renal uptake, usually unilateral, of ^{99m}Tc -labeled polyphosphate, and all of them had documented metastatic lung carcinoma (97). Abnormally increased accumulation of ^{99m}Tc -MDP in unilateral kidney subsequently was found to result from stenosis of ipsilateral renal artery (98).

Lutrin and Goris have reported intense renal uptake of ^{99m}Tc -pyrophosphate (Fig. 17.16) following chemotherapy or irradiation (99). Also reported are splenic uptake in patients with thalassemia major (100), lung uptake in patients with uremia (101), and uptake in patients with amyloid nodules (102). Uptake of ^{99m}Tc -pyrophosphate in the necrotic liver, probably due to calcium accumulation on mitochondria after disruption of the cell membrane, has been reported (103). Splenic accumulation of ^{99m}Tc -diphosphonate in the bone scan of a patient with sickle cell anemia may be associated with splenic infarction and subsequent calcium deposition (104). Diffuse lung uptake of the bone scanning agent appears to reflect metastatic pulmonary calcification (105). There was an unusual report of ^{99m}Tc -pyrophosphate uptake in a muscle hernia of the thigh (106). Diffuse soft-

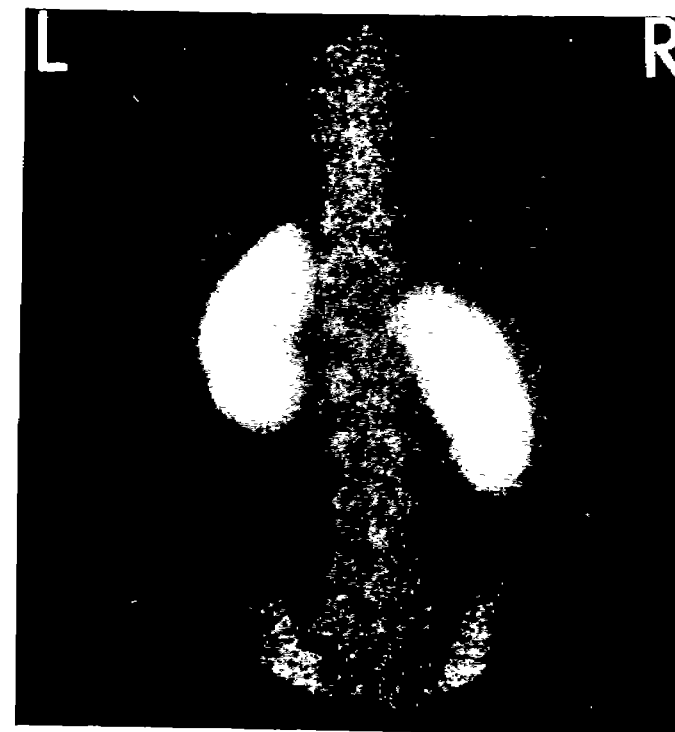

Figure 17.16. Posterior image of the lumbar spine which was obtained with use of ^{99m}Tc -MDP shows intense uptake of radioactivity in both kidneys. The patient received multiple courses of chemotherapy.

tissue uptake of ^{99m}Tc -pyrophosphate was noted in a patient with calcinosis universalis (107) and electric burn (Fig. 17.17), and ^{99m}Tc -MDP was localized in the skin lesions of a patient with pseudoxanthoma elasticum (108). Accumulation of ^{99m}Tc -MDP in the muscle of a patient with myophosphorylase deficiency and of ^{99m}Tc -MDP uptake in the diaphragm of a patient after severe ischemia have been described (109, 110).

Radionuclide Bone Marrow Imaging

Nonvisualization of the femoral head in a ^{99m}Tc -labeled SC marrow scan is commonly due to aspect necrosis and traumatic fracture and dislocation, but it has been uncommonly seen in patients with Paget's disease, amyloidosis, pheochromocytoma, Gaucher's disease, primary liver disease, and pancreatitis (111-115).

^{67}Ga -CITRATE

There have been a few reports to ^{67}Ga -citrate uptake in fractures including stress fracture (116), although Deysine et al. (117) reported no alteration in ^{67}Ga uptake in acute fractures. Diffuse pulmonary concentration of ^{67}Ga -citrate (Fig. 17.18) usually is associated with active pneumoconiosis, interstitial pneumonitis, and chemotherapy. It rarely has been seen in diffuse carcinomatosis, leukemia, disseminated lupus erythematosus, and idiopathic pulmonary fibrosis (118). There have been reports of ^{67}Ga uptake in a benign noninfected thymic cyst (119) and without evidence of bacterial endocarditis (120). Marked accumulation of ^{67}Ga -citrate has been noted in neurogenic arthropathy (121) or tuberous sclerosis (122). Giant lymph node hyperplasia resembling abdominal abscess was visualized on a gallium scan (123). Persistent

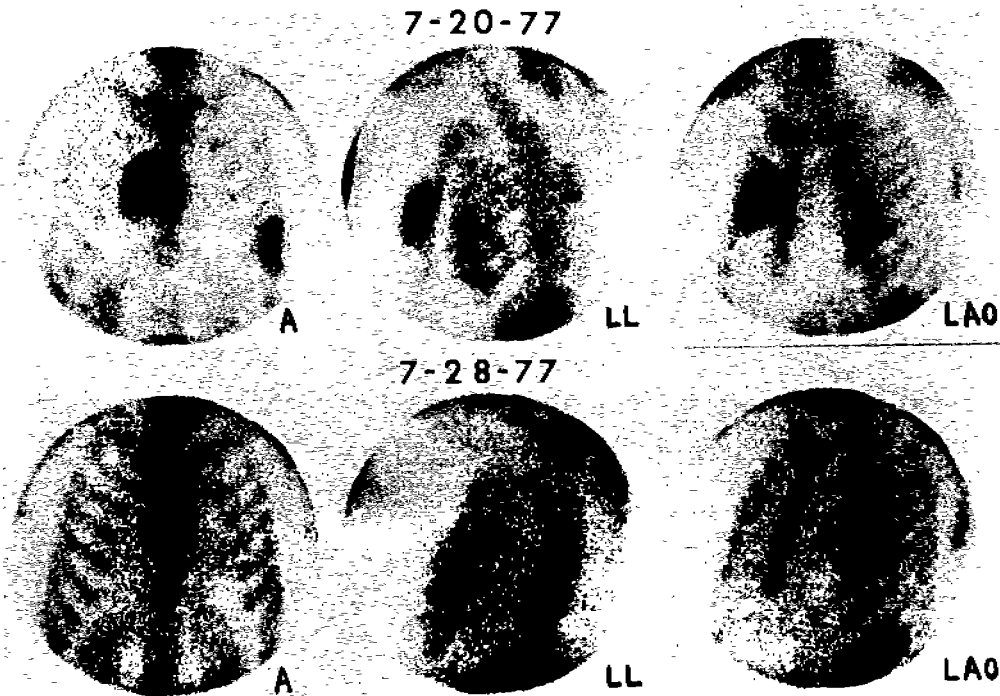

Figure 17.17. Anterior (A), left lateral (LL), and left anterior oblique (LAO) views of the chest obtained with use of ^{99m}Tc -pyrophosphate show marked abnormal activities in the areas of cardioversion. Note the changes after 8 days.

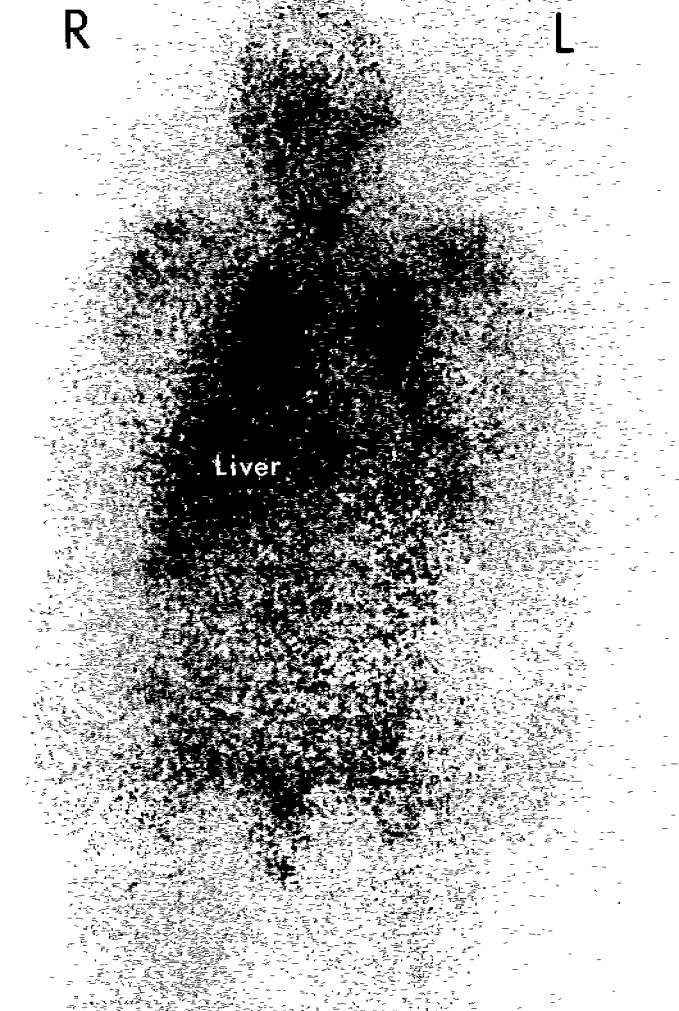

Figure 17.18. Anterior whole-body images at 48 hours following the ingestion of ^{67}Ga -citrate show marked abnormal activities diffusely in both lungs, associated with bleomycin toxicity.

renal accumulation of ^{67}Ga at 48 or 72 hours in patients with severe hepatocellular disease without renal pathology has been described and may be associated with less gallium in their livers, which allows more to be available for renal excretion (124). Decreased radioactivity uptake was noted on both bone and gallium scans in a patient with acute hematogenous osteomyelitis

of the right ilium (125). The mechanism of decreased gallium uptake is unknown but may be associated with decreased blood flow.

ACKNOWLEDGMENTS

The authors thank Bill Hladik for his advice and Ms. Linda Watts for the typing of this manuscript.

REFERENCES

- Leveille J, Pison C, Karakand Y, et al: Technetium-99m glucoheptonate in brain tumor detection: an important advance in radiotracer techniques. *J Nucl Med* 18:957-960, 1977.
- Schall GL, Quinn JL: Diagnosis of central nervous system disease. In Blahd W (ed): *Textbook of Nuclear Medicine*. New York, McGraw-Hill, 1971, p 236.
- Sty J, Kun L, Thorp S: Scintigraphy in acute lymphocytic cell leukemia. *J Nucl Med* 20:1101-1102, 1979.
- Hayt DB, Blatt CJ, Goldman SM, et al: Hypervascular presentation of multiple myeloma involving the skull demonstrated on encephaloscintigraphy. *J Nucl Med* 20:125-126, 1979.
- Sty JR, Starshak RJ, Casper JT: Extraosseous accumulation of ^{99m}Tc MDP in metastatic intracranial neuroblastoma. *Clin Nucl Med* 8:26-27, 1983.
- Kim EE: Ring sign in radionuclide cerebral images. *Semin Nucl Med* 11:168-169, 1981.
- Sty JR, Swick H: "Doughnut" sign in adrenoleukocystrophy. *Clin Nucl Med* 3:158-159, 1978.
- Polga JP, Dann RH: Sebaceous cysts of the scalp presenting as doughnut lesion in radionuclide brain imaging. *Clin Nucl Med* 3:300, 1978.
- Yarnall P, Burdick D, Sanders B: The "hot stroke." *Arch Neurol* 30:65-69, 1974.
- Wilson MA: Prolonged partial epilepsy: a case report. *Radiology* 137:500, 1980.
- Fulmer LR, Skakianakis GN: Cerebral ventricle visualization during brain scanning with ^{99m}Tc pertechnetate. *J Nucl Med* 15:202-204, 1974.
- Moinuddin M, Rochett SF: Intraventricular hemorrhage demonstrated on brain scan. *Clin Nucl Med* 2:433-434, 1977.
- Sherkow LH: Chemotherapeutic neurotoxicity on brain scintigraphy. *Clin Nucl Med* 4:439-440, 1979.
- Tator CH, Murray S: The value of CSF radioisotope studies in the diagnosis and management of hydrocephalus. In Harbert JC et al (eds): *Cisternography and Hydrocephalus*. Springfield, Charles C Thomas Publishers, 1972, p 249.
- Harbert JC, Rocha AFG: The central nervous system. In Rocha AFG, Harbert JC: *Textbook of Nuclear Medicine: Clinical Applications*. Philadelphia, Lea & Febiger, 1979, p 51.
- Kim E, Kumar B: Discrepant imaging of nodular hyperplasia with pertechnetate and radioiodine. *Clin Nucl Med* 1:204-205, 1976.
- Abdel-Nabi H, Scheu J, Ragasin R, et al: Thyroid uptake of ^{99m}Tc compromising in-vivo RBC tagging. *J Nucl Med* 22:1018-1019, 1981.
- Shimkin PM, Sagerman RH: Lymphoma of the thyroid gland. *Radiology* 92:812-816, 1969.
- Haegert DG, Wang NS, Farrer PA, et al: Non-chromaffin paragangliomatosis manifesting as a cold thyroid nodule. *Am J Clin Pathol* 65:561, 1974.
- Damascel B, Preda S, La Monica G, et al: Giant arteriovenous fistula in thyroid tumor inducing cardiac failure—selective angiography. *Br J Radiol* 45:531-534, 1972.
- Ghose MK, Genuth SM, Abellera RM, et al: Functioning primary thyroid carcinoma and metastasis producing hyperthyroidism. *J Clin Endocrinol Metab* 33:639-646, 1971.
- Ryo UY, Stachura ME, Schneider AB, et al: Significance of extrathyroidal uptake of ^{99m}Tc and I-123 in the thyroid scan: concise communication. *J Nucl Med* 22:1039-1042, 1981.
- Parthasarathy KL, Shimaoka L, Bakshi SP, et al: Radiotracer uptake in medullary carcinoma of the thyroid. *Clin Nucl Med* 5:45-48, 1980.
- Abdel-Razzak M, Christie JH: Thyroid carcinoma in an autonomously functioning nodule. *J Nucl Med* 20:1001-1002, 1979.
- Duong RB, Fernandez-Ulloa M, Planitz MK, et al: I-123 breast uptake in a young primipara with postpartum transient thyrotoxicosis. *Clin Nucl Med* 8:35, 1983.
- Tonami N, Bunko H, Kuwajima A, et al: Increased localization of Tl-201 chloride in subacute thyroiditis. *Clin Nucl Med* 4:3-5, 1979.
- Bunko H, Nakajima K, Tonami N, et al: Visualization of hypertrophied papillary muscle mimicking left ventricular mass on gated blood pool and Tl-201 myocardial perfusion imaging. *Clin Nucl Med* 6:571-574, 1981.
- Bingham JB, McKusick KA, Strauss HW: Right atrial enlargement—cardiac imaging. *Semin Nucl Med* 10:195-196, 1980.
- Sasse L, Loventzen D, Alvarez H: Paradoxical septal motion secondary to right ventricular tumor. *JAMA* 234:955-956, 1975.
- Eslami B, Roitman D, Karp RB, et al: Paradoxical septal motion in a patient with pulmonary stenosis. *Chest* 67:244-246, 1975.
- Katdare AV, Vengsarkar AS, Nair KG: Echocardiographic features of the interventricular septal motion in constrictive pericarditis. *J Postgrad Med* 25:214-218, 1979.
- Glatt BS, Rowe RD: Cerebral arteriovenous fistula associated with congestive heart failure in the newborn. *Pediatrics* 26:596-603, 1960.
- Mishkin FS: Lung curve indicating a left to right shunt in an infant with a large heart. *Semin Nucl Med* 11:161-164, 1981.
- Duska F, Vizda T, Kubicek J, et al: The sensitivity of scintigraphic myocardial imaging by the use of ^{99m}Tc-labeled pyrophosphate in the diagnosis of cardiomyopathy of various etiology. *Eur J Nucl Med* 4:87-90, 1979.
- Janowitz WF, Serafini AN: Intense myocardial uptake of ^{99m}Tc-diphosphonate in a uremic patient with secondary hyperparathyroidism and pericarditis: case report. *J Nucl Med* 17:896-898, 1976.
- Lessem J, Persson B: Myocardial scintigraphy in Chagas' disease. *Lancet* 2:310-311, 1977.
- Harford W, Weinberg MN, Buja LM, et al: Positive ^{99m}Tc-stannous pyrophosphate myocardial image in a patient with carcinoma of the lung. *Radiology* 122:747-748, 1977.
- Kim E: Calcified costal cartilage as a cause of false interpretation on myocardial imaging. *Clin Nucl Med* 1:159-161, 1976.
- Seid K, Lin D, Flowers WM: Intense myocardial uptake of ^{99m}Tc-MDP in a case of hypercalcemia. *Clin Nucl Med* 6:565-566, 1981.
- Braun SD, Lisbona R, Novales-Diaz JA, et al: Myocardial uptake of ^{99m}Tc-phosphate tracer in amyloidosis. *Clin Nucl Med* 4:244-245, 1979.
- Gomes MN, Hufnagel CA: Superior vena cava obstruction. *Ann Thorac Surg* 20:344-359, 1975.
- Simon H: Ventilation perfusion mismatch lung scan without pulmonary emboli. *Clin Nucl Med* 2:124-127, 1977.
- Myerson PJ, Myerson PA, Katz R, et al: Gallium imaging in pulmonary artery sarcoma mimicking pulmonary embolism. Case report. *J Nucl Med* 17:893-895, 1976.
- Sy WM, Nissen AW: Radionuclide studies in hemangioendotheliomatosis. Case report. *J Nucl Med* 16:915-917, 1975.
- Mendelson DS, Train JS, Goldsmith SJ, et al: Ventilation-perfusion mismatch due to obstruction of pulmonary vein. *J Nucl Med* 22:1062-1063, 1981.
- Sziklas JJ, Rosenberg R, Spencer RP: V/Q mismatch due to systemic arterial supply. *Clin Nucl Med* 4:231-232, 1979.
- Weissmann HS, Steingart RM, Kiely TM, et al: Myocardial visualization on a perfusion lung scan. *J Nucl Med* 21:745-746, 1980.
- Kramer EL, Tiu S, Sanger JJ, et al: Radioxenon retention in the skeleton on a routine ventilation study. *Clin Nucl Med* 8:299-300, 1983.
- Madeddu G, Constanza C, Casu AR, et al: Pulmonary cyst evidenced by Ga-67 citrate scan. *J Nucl Med* 21:599-600, 1980.
- Fiori-Ratti L, de Campora E, Senin U: Sequential scintigraphy: a morphological and functional study of the salivary glands. *Laryngoscopy* 87:1086-1094, 1977.
- Wilson GA, Lerner RM, O'Mara RE: "Hot spot" on liver scan produced by inferior vena cava obstruction. *Clin Nucl Med* 5:492-493, 1980.
- Mettler FA, Christie JH: Another cause of the hepatic "hot spot": Isolated innominate vein obstruction. *Clin Nucl Med* 5:514-515, 1980.
- Sandler MS, Park CH, Lin D, et al: "Hot spot" on liver scan due to tricuspid insufficiency. *Clin Nucl Med* 5:494-496, 1980.
- Volpe JA, Johnston GS: "Hot hepatic hemangioma. A unique radiocolloid-concentrating liver scan lesion. *J Surg Oncol* 2:373-377, 1970.
- Chayes Z, Keoningsberg M, Freeman L: The hot hepatic abscess. *J Nucl Med* 15:305-306, 1974.
- Volpe JA, McRae J, Johnston GS: Transmission scintigraphy in the evaluation of subphrenic abscess. *Am J Roentgenol* 109:733-734, 1970.
- Utz JA, Lull RJ, Anderson JH, et al: Hepatoma visualization with ^{99m}Tc pyridoxylidene glutamate. *J Nucl Med* 21:747-749, 1980.
- Hinkle GH, Leonard JC, Krous HF, et al: Absence of hepatic uptake of ^{99m}Tc sulfur colloid in an infant with Coxsackie B₂ viral infection. *Clin Nucl Med* 8:246-248, 1983.
- Lecklitner ML, Rosen PR, Nusynowitz ML: Cholescintigraphy: gallbladder nonvisualization secondary to neoplasm. *J Nucl Med* 22:699-700, 1981.
- Ohr HJ, Posalaky IP, Shafer RB: Normal gallbladder scintigraphy in acute cholecystitis. *Clin Nucl Med* 8:97-100, 1983.
- Cannon JR, Long RF, Berens SV, et al: Uptake of ^{99m}Tc PIPIDA in pulmonary metastases from a hepatoma. *Clin Nucl Med* 5:22-24, 1980.
- Kim EE: Focal splenic defect. *Semin Nucl Med* 9:320-321, 1979.
- Balachandran S, Kumar R, Kuo T-T: Functional asplenia in Sézary syndrome. *Clin Nucl Med* 5:149-151, 1980.
- Dhawan VM, Spencer RP, Sziklas JJ: Reversible functional asplenia in chronic aggressive hepatitis. *J Nucl Med* 20:34-36, 1979.
- Hazenberg HJA, Hiddink HJM, Link EAM, et al: In-111 leukocyte scanning and partial functional asplenia in a patient with Sézary syndrome. *Clin Nucl Med* 8:3-6, 1983.
- Lin DA: "Hot" spleen on ^{99m}Tc sulfur colloid images. *Clin Nucl Med* 8:237-238, 1983.
- Bowen BM, Coates G, Garnett ES: Technetium-99m-sulfur colloid lung scan in patients with histiocytosis X. *J Nucl Med* 16:332-334, 1975.
- Klingensmith III WC, Ryerson TW, Corman JL: Lung uptake of ^{99m}Tc-sulfur colloid in organ transplantation. *J Nucl Med* 14:757-759, 1973.
- Johnson RA, Hladik WB: Post-traumatic pulmonary accumulation of ^{99m}Tc sulfur colloid. *J Nucl Med* 23:147-148, 1982.
- Smith FW, Brown RG, Ash JM, et al: Accumulation of ^{99m}Tc sulfur colloid by the lung and kidney following disseminated intravascular coagulation. *Clin Nucl Med* 5:241-244, 1980.
- Klingensmith WC III, Datu JA, Burdick DC: Renal uptake of ^{99m}Tc-sulfur colloid in congestive heart failure. *Radiology* 127:185-187, 1978.
- Kadir S, Strauss HW: Evaluation of inflammatory bowel disease with ^{99m}Tc-DTPA. *Radiology* 130:443-446, 1979.
- Gray HW, Cuthbert I, Richards JR: Clinical imaging with ¹¹¹In leukocytes: uptake in bowel infarction. *J Nucl Med* 22:701-702, 1981.
- Pedell L, Fink-Bennett D: Technetium-99m DTPA splenic uptake. *J Nucl Med* 22:798-799, 1981.
- Ueno K, Hariki K, Kawamura Y: Unusual vertebral and pelvic visualization during ^{99m}Tc-Sn-DTPA renal dynamic study in a leukemic patient. *Clin Nucl Med* 4:20-23, 1979.
- Wilson MA, Pastakia B: Biliary excretion of Tc-99m glucoheptonate in poor renal function. *Clin Nucl Med* 5:448-449, 1980.

77. Sauerland BA, Rosen PR, Weiland FL, et al: Uptake of Tc-99m glucoheptonate in cervical lymph node metastasis from large-cell bronchogenic carcinoma. *Clin Nucl Med* 8:31-33, 1983.
78. Sacks GA, Sandler MP, Partain CL: Renal allograft recovery subsequent to apparent "hyperacute" rejection based on clinical scintigraphic and pathologic criteria. *Clin Nucl Med* 8:60-63, 1983.
79. George EA, Codd JE, Newton WT, et al: Further evaluation of ^{99m}Tc-sulfur colloid accumulation in rejecting renal transplants in man and a canine model. *Radiology* 116:121-126, 1975.
80. Martin-Comin J, Roca M, Grino JM, et al: In-111 oxine autologous labeled platelets in the diagnosis of kidney graft rejection. *Clin Nucl Med* 8:7-10, 1983.
81. Thrall JH, Freitas JE, Beierwaltes WH: Adrenal scintigraphy. *Semin Nucl Med* 8:23-41, 1978.
82. Holder LE, Matire JR, Holmes ER II, et al: Testicular radionuclide angiography and static imaging: anatomy scintigraphic interpretation and clinical indications. *Radiology* 125:739-752, 1977.
83. Kim EE, DeLand FH: Myelofibrosis presenting as hypermetabolic bone disease by radionuclide imaging in a patient with asplenia. *Clin Nucl Med* 3:406-408, 1978.
84. Mason BA, Kressel BR, Cashdollar MR, et al: Periostitis associated with myelofibrosis. *Cancer* 43:1568-1571, 1979.
85. Valdez VA, Jacobstein JG: Decreased bone uptake of technetium-99m polyphosphate in thalassemia major. *J Nucl Med* 21:47, 1980.
86. Kim EE, DeLand FH, Maruyama Y, et al: Decreased uptake in bone scans (cold lesions) in metastatic carcinoma. *J Bone Joint Surg* 60A:844-846, 1978.
87. Woolfenden JM, Pitt MJ, Durie BGM, et al: Comparison of bone scintigraphy and radiography in multiple myeloma. *Radiology* 134:723-728, 1980.
88. Makhija MC: Fibrosarcoma: photopenic lesion on a bone scan. *Clin Nucl Med* 8:265-266, 1983.
89. Bushnell D, Shirazi P, Khedkar N, et al: Ewing's sarcoma as a "cold" lesion on bone scans. *Clin Nucl Med* 8:173-174, 1983.
90. Prather JL, Harris WT, Chisholm DP: An abdominal aortic aneurysm demonstrated on bone scintigraphy as a photon-deficient region. *Clin Nucl Med* 4:172, 1979.
91. Greene G, Maurer AH, Malmud LS, et al: "Cold spot" imaging with gas gangrene in three phase skeletal scintigraphy. *Clin Nucl Med* 8:410-412, 1983.
92. Valdez VA, Jacobstein JG: Visualization of a malignant pericardial effusion with ^{99m}Tc EHDP. *Clin Nucl Med* 5:210-212, 1980.
93. Gordon L, Schabel SI, Holland RD, et al: ^{99m}Tc methylene diphosphonate accumulation in ascitic fluid due to neoplasm. *Radiology* 139:699-701, 1981.
94. Smith FW, Gilday DL, Ash JM, et al: Primary neuroblastoma uptake of ^{99m}Tc-methylene diphosphonate. *Radiology* 137:501-504, 1980.
95. Chew FS, Hudson TM: Radionuclide imaging of lipoma and liposarcoma. *Radiology* 136:741-745, 1980.
96. Sarmiento AH, Alba J, Lanaro AE, et al: Evaluation of soft tissue calcification in dermatomyositis with ^{99m}Tc-phosphate compounds. Case report. *J Nucl Med* 16:467-468, 1975.
97. Fitzer PM: Renal imaging in ^{99m}Tc polyphosphate bone scanning. Focal increased renal uptake in metastatic carcinoma of the lung. *J Nucl Med* 16:602, 1975.
98. Lantieri RL, Lin MS, Martin W, et al: Increased renal accumulation of ^{99m}Tc MDP in renal artery stenosis. *Clin Nucl Med* 5:305-309, 1980.
99. Lutrin CL, Goris ML: Pyrophosphate retention by previously irradiated renal tissue. *Radiology* 133:207-210, 1979.
100. Front D, Hardoff R, Mashour N: Splenic accumulation of ^{99m}Tc diphosphonate in thalassemia major. *J Nucl Med* 19:974-975, 1978.
101. DeGraaf P, Schicht JM, Panwels EKJ, et al: Bone scintigraphy in uremic pulmonary calcification. *J Nucl Med* 20:201-206, 1979.
102. Moyle JW, Spies SM: Bone scan in a case of amyloidosis. *Clin Nucl Med* 5:51-52, 1980.
103. Lyon KP, Kuperus J, Green HW: Localization of ^{99m}Tc pyrophosphate in the liver due to massive liver necrosis: case report. *J Nucl Med* 18:550-552, 1977.
104. Goy W, Crowe WJ: Splenic accumulation of ^{99m}Tc diphosphate in a patient with sickle cell disease: case report. *J Nucl Med* 17:108-109, 1976.
105. Rosenthal DI, Chandler HL, Azizi F, et al: Uptake of bone imaging agents by diffuse pulmonary metastatic calcification. *Am J Roentgenol* 129:871-874, 1977.
106. Shigeno C, Fukunaga M, Yamamoto I, et al: Accumulation of ^{99m}Tc pyrophosphate in a muscle hernia of the thigh. *Eur J Nucl Med* 6:425-428, 1981.
107. Powers TA, Tonya JJ: ^{99m}Tc pyrophosphate bone scan in calcinosis universalis. *Clin Nucl Med* 5:302-304, 1980.
108. Lunia S, Chodos RB, Vedder DK: Localization of ^{99m}Tc MDP in skin lesions of pseudoxanthoma elasticum. *Clin Nucl Med* 4:196-197, 1979.
109. Brumback RA: Muscle accumulation of ^{99m}Tc diphosphonate in myophosphorylase deficiency and other disorders of muscle glycogenolysis/glycolysis. *Clin Nucl Med* 8:165-166, 1983.
110. Howman-Giles R, Rahilly PM: Technetium-99m methylene diphosphonate accumulation in the diaphragm after severe ischemia. *Clin Nucl Med* 8:416-417, 1983.
111. Fletcher JW, Butler RL, Henry RE, et al: Bone marrow scanning in Paget's disease. *J Nucl Med* 14:928-930, 1973.
112. Weinfeld A, Stern MH, Marx L: Amyloid lesions of bone. *Am J Roentgenol* 180:799-805, 1970.
113. Becker MH, Redish W, Messina EJ: Bone and microcirculatory changes in a child with benign pheochromocytoma. *Radiology* 88:487-490, 1967.
114. Hungerford DS, Zizic TM: Alcoholism associated with ischemic necrosis of the femoral head. *Clin Orthop* 130:144-153, 1978.
115. Immelman EF, Bark S, Kriget, et al: Roentgenologic and clinical features of intramedullary fat necrosis in bones in acute and chronic pancreatitis. *Am J Med* 36:96-105, 1964.
116. Marta JB, Williams HJ, Smookler RA: ⁶⁷Ga uptake in a stress fracture. *J Nucl Med* 23:271-272, 1982.
117. Deysine M, Rafkin H, Teicher I, et al: Diagnosis of chronic and postoperative osteomyelitis with ⁶⁷Ga citrate scans. *Am J Surg* 129:632-635, 1975.
118. Kim EE: Diffuse pulmonary gallium concentration. *Semin Nucl Med* 10:108-110, 1980.
119. Jensen SR, Rao BR, Winebright JW, et al: Gallium-67 uptake in a benign thymic cyst. *Clin Nucl Med* 5:67, 1980.
120. Schor RA, Massie BM, Botvinick EH, et al: Gallium-67 uptake in silent myocardial infarction: a case report. *Radiology* 129:117-118, 1978.
121. Glynn TP Jr: Marked gallium accumulation in neurogenic arthropathy. *J Nucl Med* 22:1016-1017, 1981.
122. Rashad FA, Miraldi FD, Bellon EM: Gallium-67 uptake in tuberous sclerosis. *Clin Nucl Med* 4:242-243, 1979.
123. Wahner HW, Goellner JR, Hoagland HC: Giant lymph node hyperplasia resembling abdominal abscess on gallium scan. *Clin Nucl Med* 3:19-21, 1978.
124. Alazraki N, Sterkel B, Taylor A Jr: Renal gallium accumulation in the absence of renal pathology in patients with severe hepatocellular disease. *Clin Nucl Med* 8:200-204, 1983.
125. Ang JGP, Gelfand MJ: Decreased gallium uptake in acute hematogenous osteomyelitis. *Clin Nucl Med* 8:301-303, 1983.

18

Clinical Manifestations of Radiopharmaceutical Formulation Problems

James A. Ponto, Dennis P. Swanson, and John E. Freitas

Unexpected patterns of radiopharmaceutical biodistribution usually provoke a flurry of inquiries regarding the quality of the administered agent. Although this unexpected biodistribution may be related to nonradiopharmaceutical factors (discussed in other chapters of this book), past experience has shown that an improperly formulated radiopharmaceutical may be to blame.

The clinical manifestations of most ^{99m}Tc radiopharmaceutical formulation problems are generally associated with increased amounts of [^{99m}Tc]pertechnetate, ^{99m}Tc -labeled colloid, and/or ^{99m}Tc particulate impurities in the desired ^{99m}Tc agent. Free pertechnetate is distributed throughout the vasculature and interstitial fluid and is concentrated in the stomach, intestinal tract, thyroid gland, and salivary glands; the presence of free ^{99m}Tc -pertechnetate* impurities will, therefore, result in increased activity in these organs (Fig. 18.1). Colloid particles are phagocytized by cells of the reticuloendothelial system (RES) which are located primarily in the liver and spleen; the presence of ^{99m}Tc -labeled colloid impurities will, therefore, result in increased activity in the liver and spleen (Fig. 18.2). Large ($>10\ \mu$) particles administered intravenously become physically lodged in the pulmonary capillaries;

the presence of large ^{99m}Tc particulate impurities will, therefore, result in increased activity in the lungs (Fig. 18.3).

In this chapter, common formulation factors which affect the level of these impurities in ^{99m}Tc -labeled radiopharmaceuticals are discussed. In addition, formulation factors that may produce alternate effects on the biodistribution of ^{99m}Tc -labeled tracers and other radiopharmaceuticals are presented. These clinical manifestations of common radiopharmaceutical formulation problems are summarized in Table 18.1.

CARRIER ^{99}Tc

^{99m}Tc undergoes isomeric transition to the very long lived isotope ^{99}Tc (half-life, 200,000 years), which can, for practical purposes, be considered stable in comparison to its metastable isomer. The decay of ^{99m}Tc , therefore, results in a rapid buildup of carrier technetium with corresponding depression of ^{99m}Tc -specific activity. Excessive carrier ^{99}Tc is commonly present in the eluate of a generator which has not been eluted for several days. Expressed as a percentage of total technetium atoms (^{99m}Tc plus ^{99}Tc) obtained in the generator eluate, ^{99m}Tc comprises 28% of the total at 24 hours, 13% at 48 hours, and only 8% at 72 hours after prior elution (1, 2).

^{99}Tc , which is chemically identical to all other technetium isotopes, can compete with ^{99m}Tc for the reductive capacity and the ligand-

* Although [^{99m}Tc]pertechnetate is preferred by IUPAC, ^{99m}Tc -pertechnetate is standard, and both are used throughout this chapter.



Figure 18.1. ^{99m}Tc -pyrophosphate bone scan demonstrating free pertechnetate distribution in the stomach, intestinal tract, thyroid, and salivary glands (arrows).

Figure 18.2. ^{99m}Tc -pyrophosphate bone scan demonstrating colloidal impurities in the liver (arrow).

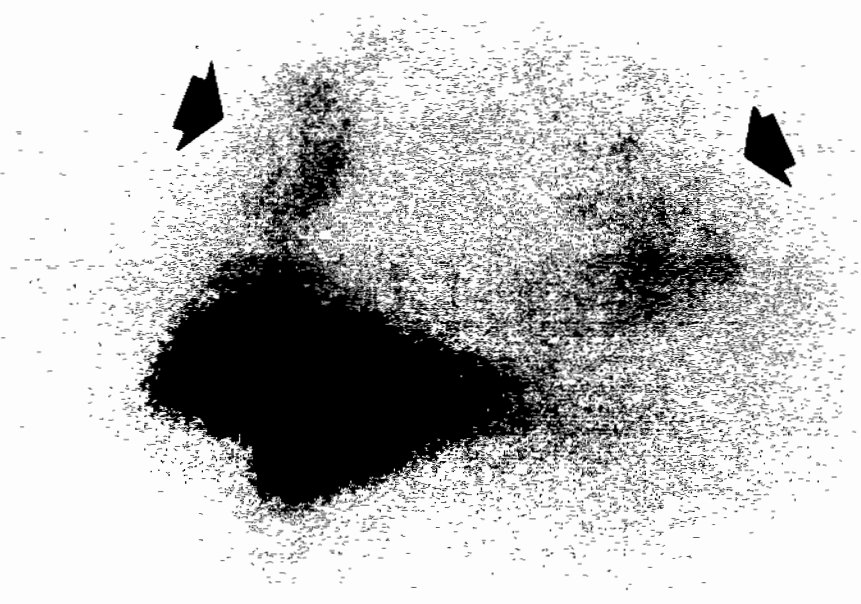

Figure 18.3. ^{99m}Tc -labeled sulfur colloid liver scan demonstrating particulate impurities in the lungs (arrows).

binding sites of fixed concentrations of stannous ion and chelating reagents, respectively. Hence, it is not surprising that an unacceptably high concentration of unreduced, free ^{99m}Tc -pertechnetate impurity has been found in many ^{99m}Tc -labeled radiopharmaceuticals prepared with use of low-specific-activity Monday morning generator eluates. This effect has been reported with the preparation of ^{99m}Tc -labeled sulfur colloid (3), gluconate (4), human serum albumin (HSA) (5), red blood cells (RBC) (6–8), and diethylenetriaminepentaacetic acid (DTPA) (9) and may occur with many other ^{99m}Tc preparations (2, 6). Even if the reductive capacity of the kit is not exceeded, high levels of ^{99}Tc or ^{99m}Tc may affect the biodistribution of the labeled product. For example, blood clearance rates of ^{99m}Tc -hydroxymethylene diphosphonate (HDP) prepared with high levels of either ^{99}Tc or ^{99m}Tc are significantly slower than those prepared with less total technetium (10).

ALUMINUM ION

The distribution of a number of ^{99m}Tc -labeled radiopharmaceuticals may be altered by the aluminum ion (Al^{+3}). The most common source of excessive Al^{+3} is breakthrough from the aluminum oxide anion exchange column in the $^{99}\text{Mo}/^{99m}\text{Tc}$ generator. If the Al^{+3} breakthrough is present, it generally occurs with the first generator elution (11, 12), although Al^{+3} concentrations may vary from day to day and from manufacturer to manufacturer (13). Al^{+3} breakthrough was much more of a problem with the older, large-column, neutron-activated ^{99}Mo generators than it is with the present, small-column, fission ^{99}Mo generators (14, 15). Limits for the amount of permissible Al^{+3} breakthrough have been established in the *United States Pharmacopeia* (U.S.P.), whereby Al^{+3} concentrations cannot exceed 10 $\mu\text{g}/\text{ml}$ generator eluate (16).

Table 18.1.
Clinical Manifestations of Common Radiopharmaceutical Formulation Problems

Radiopharmaceutical	Formulation Problem	Clinical Manifestation	Reference
Pertechnetate	Al^{+3}	Sustained blood pool localization	25, 26
	Stannous ion	↑ liver and spleen uptake	32, 44
^{99m}Tc -labeled sulfur colloid and Sn colloid	Preparation with bacteriostatic saline	↑ blood pool, liver, and spleen activity	153
	Carrier ^{99}Tc	↓ free pertechnetate	3
	Al^{+3}	Lung uptake	12–14, 17–21
	Alkaline pH	↑ free pertechnetate	41, 42
	Incorrect order of mixing	↑ free pertechnetate	17, 58
	Radiolytic decomposition and/or oxidation	↑ free pertechnetate	41
	Sterilization with iodinated antiseptics	↑ free pertechnetate	116
	Particle clumping	Lung uptake	41, 190
	Particle settling and/or absorption to vial	↓ activity per volume withdrawn	41, 96, 97
	Low heating temperature	↑ free pertechnetate	61
	Inadequate boiling time	↑ free pertechnetate	14, 17, 41, 61, 65
		↓ spleen uptake	14, 41
	Excessive boiling time	Lung uptake	14, 41
	Heating large volume	↑ free pertechnetate	17
	Commercial source	↑ free pertechnetate	3, 98
Low specific activity	↓ liver uptake; ↑ bone marrow uptake	82	
^{99m}Tc -labeled phosphates and diphosphonates	Variable incubation time	Variable particle size	74
	Carrier ^{99}Tc	Slower blood pool clearance	10
	Al^{+3}	↑ liver and kidney uptake	22–24
	Alkaline pH	↑ liver and kidney uptake	24, 32, 45–47
	Inadequate stannous	↑ free pertechnetate	31, 34, 56, 191
	Excess stannous	↑ liver and soft tissue uptake	32, 34, 128
	Preparation with bacteriostatic saline	↑ free pertechnetate	153
	Improper mixing order	↑ blood pool activity; ↑ liver uptake	56
	Low ligand concentration	↓ bone uptake; ↓ soft tissue and kidney uptake	46, 60
	Radiolytic decomposition and/or oxidation	↑ free pertechnetate	31–34, 56, 119, 122, 125, 126, 128–131
^{99m}Tc -HSA	Inadequate or prolonged incubation time	↓ bone; soft tissue uptake	73, 76–79
	Commercial source	↑ soft tissue uptake; liver, gallbladder, and/or intestinal localization	79, 99, 105–107
	Carrier ^{99}Tc	↑ free pertechnetate	5
	Improper pH	↑ free pertechnetate; ↑ liver uptake	39
	Improper mixing order	↑ liver uptake	39
	Radiolytic decomposition and/or oxidation	↑ free pertechnetate	33
	Commercial source	↑ free pertechnetate; differences in blood clearance rates and liver uptake	98, 100, 192

Table 18.1—continued

Radiopharmaceutical	Formulation Problem	Clinical Manifestation	Reference
^{99m} Tc-labeled macro-aggregated albumin and albumin microspheres	Soluble protein	↑ blood pool activity	80, 81
	Small particles	↑ liver uptake	80, 90
	Clumping of particles	Focal hot spots in lungs	90, 93
	Inadequate number of particles	Perfusion defects, especially peripheral patchiness	94, 95
	Excessive number of particles	↑ risk of toxicity	94, 95
	Radiolytic decomposition and/or oxidation	↑ free pertechnetate	80
	Settling of particles	Inadequate number of particles in suspension	
^{99m} Tc-labeled RBC	Carrier ^{99m} Tc AI ³⁺	↑ free pertechnetate	6–8
	Very acidic pH	RBC agglutination	27
	Inadequate stannous	RBC hemolysis	27
	Excessive stannous	↑ free pertechnetate	7, 36, 192
		↑ plasma activity	7, 35–38, 193
		↑ spleen uptake	194
	Improper mixing order	↑ liver uptake	7
	Low cell concentration	↓ rate and extent of labeling	37
	Radiolytic decomposition and/or oxidation	↑ free pertechnetate	36, 193
	Inadequate incubation time	↑ free pertechnetate	36, 37, 71, 72, 193
	Incubation at lower than 37° C	↓ rate of labeling; ↑ free pertechnetate	37, 72
	Heparin versus ACD	↓ labeling efficiency; ↑ extravascular activity; ↑ urinary excretion	8
	^{99m} Tc-labeled damaged RBC	Excess ACD	Sequestration in spleen
Low heating temperature		↓ spleen uptake; ↑ blood pool activity	62, 64
High heating temperature		↓ spleen uptake; ↑ liver uptake	62, 64
Inadequate heating time		↓ spleen uptake; ↑ blood pool activity	62–64, 69
Excessive heating time		↓ spleen uptake; ↑ liver uptake	62–64
Heating large volume		↓ spleen uptake; ↑ blood pool activity	68
Low specific activity		↓ spleen uptake; ↑ blood pool activity	68
^{99m} Tc-IDA derivatives		pH > 5.5	↓ rate of labeling
	Radiolytic decomposition and/or oxidation	↑ free pertechnetate	43, 124, 195
	Inadequate incubation time	↑ free pertechnetate; ↑ blood pool activity	43, 70
	Low ligand concentration	↓ rate of labeling	43
^{99m} Tc-DTPA	Carrier ^{99m} Tc	↑ free pertechnetate	9
	Inadequate stannous	↑ free pertechnetate	9, 113, 115
	Improper mixing order	↑ free pertechnetate	57
	Radiolytic decomposition and/or oxidation	↑ free pertechnetate	59, 115, 117, 121, 196
	Commercial source	Differences in renal excretion rates	101–103

Table 18.1—continued

Radiopharmaceutical	Formulation Problem	Clinical Manifestation	Reference	
^{99m} Tc-gluceptate	Improper pH	↑ free pertechnetate	40	
	Improper mixing order	↑ free pertechnetate or ↓ liver uptake	40	
^{99m} Tc-DMSA	Radiolytic decomposition and/or oxidation	↑ free pertechnetate	40, 127, 133, 135	
	Alkaline pH	Rapid urinary excretion	51–54	
	Radiolytic decomposition and/or oxidation	↑ free pertechnetate; ↓ kidney uptake; ↑ liver uptake	53, 104, 123, 197	
	Low ligand concentration	↓ kidney uptake; ↑ bone uptake	53	
	Inadequate incubation time	↓ kidney uptake; ↑ bone uptake	53	
Commercial source	Differences in adsorption onto walls and stoppers of glass vials		111	
^{99m} Tc-gluconate	Carrier ^{99m} Tc	↑ free pertechnetate	4	
	Improper mixing order	↑ liver uptake	4	
	Radiolytic decomposition and/or oxidation	↑ free pertechnetate	33	
[¹³¹ I]iodohippurate	Radiolytic decomposition and/or oxidation	↑ thyroid uptake; ↓ urinary excretion rate	118, 134, 198	
Sodium [¹³¹ I]iodide	Acidic pH	↑ thyroid uptake in personnel	168–170, 172, 174, 175	
	Radiolytic decomposition and/or oxidation	↑ thyroid uptake in personnel	171, 173, 174	
	Metal ions	↑ thyroid uptake in personnel	168, 175	
	Chlorinated tap water for dilution	↑ thyroid uptake in personnel	171	
	Storage above room temperature	↑ thyroid uptake in personnel	174, 176	
	Carrier iodide	↓ thyroid uptake	137, 138	
	Encapsulation	↓ thyroid uptake; retention of abdominal activity	156, 157	
	Sodium [¹²³ I]iodide	Radionuclidic contamination	↑ radiation dose; errors in dose calibration; image degradation	178, 180–186
	²⁰¹ Tl-chloride	Radionuclidic contamination	Image degradation	187–189
⁵⁷ Co-labeled cyanocobalamin and intrinsic factor	Carrier cyanocobalamin	↓ absorption and urinary excretion	140	
	Encapsulation	↓ absorption and urinary excretion	159–161	
⁶⁷ Ga-citrate	Isotope exchange	Spurious results	163–165	
	Commercial source	Uptake vs. no uptake in cerebral infarct	108	
Carrier gallium		↑ bone uptake; ↓ uptake in usual organs	141, 142	
¹³³ Xe solution	benzyl alcohol preservative	Spurious regional blood flow measurements	154	
Iodinated cholesterol derivatives	?	↑ liver, spleen, and bone marrow uptake	199	
	Limited solubility in vehicle	Lung uptake	148	

As early as the 1960s, it had been reported that Al^{+3} interacts with ^{99m}Tc -labeled sulfur colloid to form a flocculent precipitate (12, 14). In later studies, it was shown that this flocculation could result with Al^{+3} concentrations as low as 1 $\mu g/ml$ (17). Although the precipitate was originally thought to be aluminum hydroxide (13), it was later determined that Al^{+3} combines with the phosphate buffer to form insoluble aluminum phosphate (18, 19). A flocculent aluminum phosphate precipitate may be formed in vivo when ^{99m}Tc -labeled sulfur colloid is administered to patients exhibiting elevated plasma levels of Al^{+3} (20). In both cases, the ^{99m}Tc -labeled sulfur colloid is coprecipitated with the aluminum phosphate precipitate and results in lung localization, since these flocculated particles become lodged in the pulmonary capillaries (13, 17, 20, 21). Avoidance of this problem may be achieved with the addition of EDTA, a chelating agent for Al^{+3} , to the sulfur colloid formulation (17, 19). Additionally, it has been shown that sulfur colloid preparations formulated with an acetate buffer instead of a phosphate buffer do not flocculate in the presence of Al^{+3} (18, 19).

A second radiopharmaceutical affected by Al^{+3} is ^{99m}Tc -diphosphonate. Visualization of liver and spleen background activity have resulted from phagocytosis of a radiocolloid formed by the interaction of ^{99m}Tc -diphosphonate in the presence of elevated Al^{+3} concentrations (22–24). This effect was not seen with Al^{+3} concentrations of <10 $\mu g/ml$, but liver localization and bone scan image degradation progressed with increasing Al^{+3} concentrations above this level (22).

The biodistribution of pertechnetate may be altered by excessive Al^{+3} . Failure of ^{99m}Tc -pertechnetate to leave the vascular space was observed in a patient with a plasma aluminum level of 65 $\mu g/l$ (25). Moreover, ^{99m}Tc -pertechnetate injections containing Al^{+3} in concentrations of 4 $\mu g/ml$ or more may result in reduced thyroidal uptake of pertechnetate (26). Al^{+3} in these higher concentrations apparently interacts with pertechnetate to form neutral and ionic pertechnetate-aluminum complexes which remain in soft tissues. These complexes are relatively unstable and slowly release pertechnetate

as, over a period of hours, aluminum ion is hydrolyzed (26).

Al^{+3} also acts as an erythrocyte-agglutinating agent. Results of in vitro studies indicate a critical concentration of about 5 $\mu g Al^{+3}/ml$ at a pH range between 4 and 5. Since necessary conditions for red cell agglutination by Al^{+3} do not occur in vivo, intravascular agglutination with administration of generator eluate containing Al^{+3} appears highly improbable (27).

STANNOUS ION

The importance of an optimal amount of stannous ion (Sn^{+2}) as a reducing agent in the preparation of ^{99m}Tc -labeled radiopharmaceuticals is widely recognized. Too little Sn^{+2} limits the reductive capacity, which leads to decreased labeling efficiency and increased free ^{99m}Tc -pertechnetate impurity; too much Sn^{+2} may result in the formation of ^{99m}Tc -labeled colloid impurities and/or decreased labeling efficiency.

Most ^{99m}Tc "kits" start with sufficient, and usually excess, amounts of Sn^{+2} . This reducing capacity may be drastically decreased, however, by a variety of factors including loss of Sn^{+2} during manufacture, deterioration and/or oxidation during storage, and oxidation during kit preparation (28–32). Furthermore, excessive amounts of carrier ^{99m}Tc decrease the apparent reducing capacity by competing with ^{99m}Tc . (See also sections entitled "Carrier ^{99m}Tc " and "Oxidation and/or Radiolytic Decomposition.")

Addition of excessive amounts of Sn^{+2} to ^{99m}Tc kits is a common practice for counteracting the effects of oxidants and inhibiting radiation-induced decomposition (29, 33). Although this practice does effectively inhibit the formation of free ^{99m}Tc -pertechnetate impurities, hydrolysis of the excess Sn^{+2} can result in the formation of ^{99m}Tc -labeled stannous colloids with resultant RES and other soft-tissue localization (32, 34). On the other hand, some ^{99m}Tc -labeled radiopharmaceuticals may display decreased labeling in the presence of excess Sn^{+2} (35–38).

pH

Alterations in pH can have marked effects on the radiochemical purity and/or the final chem-

ical form of ^{99m}Tc -labeled radiopharmaceuticals. With regard to the effects of pH on radiochemical purity, it has been shown that (a) decreased labeling of $^{99m}Tc(Sn)$ -HSA and electrolytically prepared ^{99m}Tc -glucoceptate occur above or below the optimal pH ranges between 2 and 3 and 6.7 and 7.2, respectively (39, 40), (b) ^{99m}Tc -labeled sulfur colloid breaks down and liberates free ^{99m}Tc -pertechnetate at a neutral or alkaline pH (41, 42), and (c) decreased labeling rates of ^{99m}Tc -iminodiacetic acid (IDA) derivatives are observed at pH values higher than the optimal pH of 5.5 (43).

Stannous ion solutions become insoluble and form colloidal precipitates at neutral and alkaline pH. If ^{99m}Tc -pertechnetate is present, the ^{99m}Tc can coprecipitate and/or complex with the tin colloid, which would result in a radiocolloid impurity that would localize in the RES (32, 44).

Good bone uptake and urinary excretion result from use of acidic formulations of ^{99m}Tc -pyrophosphate, whereas negligible bone affinity and concentrations in the kidney result from use of neutral and alkaline formulations (45, 46). Imaging with alkaline ^{99m}Tc -pyrophosphate formulations rather than with slightly acidic formulations demonstrates significantly inferior bone scan quality (47). High liver and kidney uptake have been demonstrated when ^{99m}Tc -hydroxyethylidene diphosphonate (HEDP) is prepared at alkaline pH (24). It is not clear, however, whether these pH effects on ^{99m}Tc -labeled phosphates are solely associated with the formation of radiocolloid or free ^{99m}Tc -pertechnetate impurities, since there is evidence that suggests that the alteration in biodistribution may be a result of differing chemical complexes formed at different pH values. For example, Tc(IV)-HEDP has been identified in acidic solution, whereas Tc(V)-HEDP was formed in neutral or alkaline solutions (48). Similarly, several components showing markedly different bone uptakes and soft-tissue localizations have been separated from ^{99m}Tc -methylene diphosphonate (MDP) mixtures prepared at different pH ranges (49, 50).

A number of different complexes of ^{99m}Tc -dimercaptosuccinic acid (DMSA) have been observed at different pH values. The complex

formed under acidic conditions with relatively high Sn^{+2} concentrations was retained in the renal cortex, while another distinct complex formed at an alkaline pH with relatively low Sn^{+2} concentrations exhibited rapid urinary excretion and moderate uptake in tumor and bone (51–54). Several factors may be involved in the formation of these different complexes. For example, the ratio of DMSA to Sn^{+2} at pH 4 is 2:1, while the ratio at pH 8 is 1:1 (51, 52). Furthermore, the kidney localizing complex formed at acidic pH is probably Tc(III)-DMSA, while that formed at alkaline pH is probably Tc(V)-DMSA (54). Tc(V) may then dissociate from the DMSA complex as TcO_4^{-3} and, as a structural analog to PO_4^{-3} , may localize in some tumors and bones (54).

Different complexes of ^{99m}Tc -IDA compounds have also been observed at different pH values. Rapid conversion in vivo to a common form probably occurs, however, since the bio-distribution patterns are essentially the same (55).

MIXING ORDER

The order of mixing components in the formulation of ^{99m}Tc -labeled radiopharmaceuticals can have dramatic effects on the resulting bio-distribution. In general, the reducing agent and the chelating agent should be mixed prior to the addition of ^{99m}Tc -pertechnetate in order to obtain high labeling efficiencies. If Sn^{+2} and ^{99m}Tc -pertechnetate are combined first, an insoluble ^{99m}Tc -labeled tin colloid may be formed, with resultant increased liver activity (4, 7, 56).

Improved labeling of several ^{99m}Tc -labeled radiopharmaceuticals can be achieved with a simple alteration in the mixing order during kit formulation. Instead of reconstituting the kit with the required volume of ^{99m}Tc -pertechnetate diluted previously with normal saline, the modified procedure calls for reconstitution with concentrated ^{99m}Tc -pertechnetate, incubation for 3–5 minutes, and then dilution with an appropriate volume of normal saline (57).

The radiopharmaceutical most affected by the mixing order is ^{99m}Tc -labeled sulfur colloid. ^{99m}Tc -pertechnetate, hydrochloric acid, and

thiosulfate solutions must be combined before being heated in order to ensure a high yield. Addition of ^{99m}Tc -pertechnetate or the acid solution after heating and/or addition of the buffer solution before heating results in negligible labeling and alterations in biodistribution reflecting free ^{99m}Tc -pertechnetate (17, 58).

LIGAND CONCENTRATION

The ligand concentration is inversely proportional to the final preparation volume. Low ligand concentrations may necessitate longer incubation times and/or result in complexes having different biodistribution patterns. Therefore, preparation volumes should not be unnecessarily large.

Use of a DMSA kit prepared with 2 ml of pertechnetate yields about 90% of the kidney-localizing complex in 15 minutes, whereas a preparation volume of 10 ml yields only about 70% in 15 minutes. In both cases, the remainder of the preparation consists of a different complex which is moderately localized in the bone and rapidly excreted in the urine (53). Similarly, ^{99m}Tc -IDA derivatives prepared in a volume of 10 ml compared with those prepared in a volume of 2 ml show a decreased rate of labeling (43). Moreover, it has been found that in a number of commercially available kits, diluted ^{99m}Tc -DTPA injection becomes unstable and produces unacceptably high levels of free ^{99m}Tc -pertechnetate (59).

In addition, the rate and extent of labeling of RBC with ^{99m}Tc are affected by cell concentration. The incorporation of ^{99m}Tc into RBC is directly related to hematocrit, not to cell number (37).

Solutions of ^{99m}Tc -pyrophosphate diluted in vitro and, to a lesser extent, in vivo demonstrate decreased bone uptake and increased soft-tissue and kidney localization (46). Similarly, ^{99m}Tc -HEDP diluted in vitro demonstrates decreased bone uptake and increased soft-tissue and pertechnetate localization (60). The altered biodistribution of these two radiopharmaceuticals with dilution has been ascribed to the formation of different complexes and liberation of free pertechnetate (46, 60).

HEATING

The distribution of radiopharmaceuticals that require heating as part of their preparation may be influenced by a number of factors involved in the heating process. These factors include temperature, duration of heating, and volume heated.

Temperature plays an important role in the formation and labeling of ^{99m}Tc -labeled sulfur colloid. Because the reaction between thiosulfate and acid is slow at room temperature, the sulfur colloid reagents are heated in a boiling water bath. For consistently high labeling yields, the temperature of this water bath should be 95–100° C. Heating at temperatures of less than 95° C may result in poor labeling of the colloid and increased free ^{99m}Tc -pertechnetate impurity (61).

The temperature used to damage ^{99m}Tc - or ^{51}Cr -labeled RBC for splenic sequestration studies is critical. Too low of a temperature results in insufficient RBC damage with significant activity remaining in the blood pool; too high of a temperature results in excessive RBC damage and decreased spleen uptake with increased liver uptake (62). The recommended temperature for optimal red cell damage is 49–50° C (7, 62–64).

A second important factor is the duration of heating. When ^{99m}Tc -labeled sulfur colloid is heated at 90–100° C, its labeling efficiency initially increases rapidly and then plateaus at 3–10 minutes (14, 17, 61, 65). Heating for an insufficient length of time may decrease the labeling efficiency and increase free ^{99m}Tc -pertechnetate impurities. The length of heating also affects the colloid particle size, with the mean colloid particle diameter increasing as a function of heating time (14, 41). If the ^{99m}Tc -labeled sulfur colloid is heated for an insufficient period of time, poor splenic uptake can result, whereas if it is heated for an extended period of time, lung uptake of large "colloidal" particles may result.

The degree of radiolabeled RBC damage varies directly with the length of heating time. Inadequate or extended heating of RBC results in insufficient or excessive damage, respectively, with resultant alteration in the expected

biodistribution. Optimal duration of heating is variable, depending on the type of apparatus, volume, and suspending media (62, 66–69). The optimal length of heating time with use of the Brookhaven National Laboratory procedure appears to be 10–15 minutes (63, 66).

The third heating-related factor is the volume to be heated. Heating of small volumes is more uniform than is heating of large volumes. Sulfur colloid preparations containing >10 ml show inconsistent labeling efficiencies, when compared with smaller volume preparations boiled for the same length of time (17). Similarly, large volumes of radiolabeled RBC may demonstrate insufficient damage for splenic sequestration, when compared with small volumes heated for the same length of time (68).

INCUBATION

Although most ^{99m}Tc chelates are formed very rapidly, some complexation reactions require a substantial incubation time. In these latter reactions, labeling usually follows an exponential curve, with plateauing achieved after several minutes. Incubation times of approximately 10–15 minutes are required to reach plateau labeling for ^{99m}Tc -DMSA (53) and ^{99m}Tc -IDA derivatives (43, 70), and a 10-minute incubation time is needed for both in vitro and in vivo labeling of RBC with ^{99m}Tc (36, 71–73). Use of the agents before maximal labeling may result in increased levels of free ^{99m}Tc -pertechnetate impurities.

The in vitro particle size of ^{99m}Tc -labeled tin colloid preparation increases with the length of incubation time after reconstitution and affects the relative organ uptakes (74) (also discussed elsewhere in this chapter).

The chemical form and/or nature of a radiopharmaceutical may change during the incubation period, with resultant alterations in the biodistribution. With ^{99m}Tc -MDP, ratios of bone to soft tissue are reportedly higher after a 31–60-minute incubation period than after shorter incubation times, even though the percent labeling efficiency remains unchanged (75, 76). Apparently, a chemical form of ^{99m}Tc -MDP with a different renal clearance is slowly formed from the initial labeled product. On the other hand,

measurable deterioration in bone scan quality (with and without gastric visualization) has been reported to occur sporadically with use of incubated ^{99m}Tc -MDP (77). In these cases, a chemical form of ^{99m}Tc -MDP with an altered affinity for bone is apparently formed during incubation. Similarly, abnormal soft-tissue localization of ^{99m}Tc -HDP and ^{99m}Tc -MDP has been associated with long make-up-to-injection times (78, 79).

PARTICULATE SIZE AND NUMBER

The biodistribution of particulate radiopharmaceuticals occurs as a function of their size. Particles so small as to be considered soluble (e.g., ^{99m}Tc -labeled HSA and some other proteins) remain in the blood pool and soft tissue and may degrade image quality (80, 81). Particles in the colloid size range demonstrate RES localization; maximal bone marrow uptake is correlated with smaller colloid size (82–86), with progressive splenic localization occurring as the colloid size increases (87–89). Particles of even larger size (>10 μ) become physically trapped in capillaries and precapillary arterioles (90).

The particle size of ^{99m}Tc -labeled sulfur colloid can be influenced by a number of factors (discussed here and elsewhere in this chapter) including aluminum ion concentration, heating time and temperature, and aggregation. After preparation and during storage, ^{99m}Tc -labeled sulfur colloid particles may aggregate over time to form clumps large enough to lodge in the pulmonary capillaries and to produce lung visualization (41, 91). The use of stabilizing or protecting agents, such as gelatin, in the sulfur colloid formulation markedly improves particle size stability (91, 92). In contrast, small radiocolloids may underestimate splenic function and possibly result in a misdiagnosis of functional hyposplenia. This problem has been observed with ^{99m}Tc -labeled phytate colloid, which frequently demonstrates insufficient splenic uptake to provide images of diagnostic quality (87, 89). The splenic uptake of ^{99m}Tc -phytate can be improved by the addition of ionic calcium to induce colloid aggregation (89).

The particle size of perfusion lung imaging agents may have undesirable effects on pulmonary localization. High blood pool activity has been reported following the administration of ^{99m}Tc -labeled macroaggregated albumin preparations containing significant amounts of soluble protein (80, 81). Small particles and particle fragments $<10\ \mu$ may pass through the pulmonary capillaries and be phagocytized by the liver and spleen (80, 90). Macroaggregated albumin and albumin microsphere preparations may demonstrate clumping of the particles at storage. Injected intravenously, large particles or particulate clumps $>100\ \mu$ lodge in pulmonary arteries and result in focal hot spots on the lung image (90, 93).

The number of injected particles of macroaggregated albumin and microsphere preparations is important in terms of both image quality and toxicity. Too few injected particles may result in degradation of lung images, with definite perfusion abnormalities, especially peripheral patchiness, demonstrated (94, 95). The minimum number of particles that should be administered for a lung scan is 60 particles/gm of lung tissue or 60,000 particles for an adult patient (94, 95). Injection of $>250,000$ particles improves image quality little (95), while it increases the risk of toxicity (see Chapter 20).

Particulate radiopharmaceuticals tend to settle or sediment with time. Therefore, before a dose is withdrawn, the vial should be gently inverted several times to resuspend the particles. Failure to resuspend particles may result in withdrawal of a larger-than-expected volume, a somewhat higher percentage of soluble free ^{99m}Tc -pertechnetate in the withdrawn dose, and/or an inadequate number of particles for lung imaging. ^{99m}Tc -labeled sulfur colloid has a tendency to adsorb over time on the surfaces of the glass vial, which thus necessitates withdrawal of a larger-than-expected volume for the required radioactivity dose (41, 91, 96, 97).

COMMERCIAL SOURCE

The commercial source of reagent kits and the compatibility of generator eluates with these kits may affect the final radiochemical purity of ^{99m}Tc -labeled radiopharmaceuticals. A specific kit that yields a highly labeled product when it

is prepared with ^{99m}Tc from one generator supplier may demonstrate decreased labeling and increased free ^{99m}Tc -pertechnetate impurity when it is prepared with ^{99m}Tc from an alternate supplier. This phenomenon has been reported in the preparation of various ^{99m}Tc -labeled sulfur colloid (3, 98), ^{99m}Tc -HSA (98), and ^{99m}Tc -DTPA products (59). The biodistribution of labeled kits may be affected by the source of ^{99m}Tc . For example, abnormal soft-tissue localization is seen much more frequently when ^{99m}Tc -MDP and ^{99m}Tc -HDP are prepared with instant (methyl ethyl ketone extraction) technetium than with technetium from generators (79, 99).

Even with comparable labeling, reagent kits from different commercial sources may result in significant differences in biodistribution and elimination kinetics. Various ^{99m}Tc -HSA kits have shown differences in plasma clearance rates of up to five times (100), and various preparations of ^{99m}Tc -DTPA exhibit significantly different glomerular filtration rates (101–103). Similarly, although the renal concentrations of two ^{99m}Tc -DMSA preparations are equivalent, values for liver uptakes are markedly different (104). Moreover, hepatic, gallbladder, and/or intestinal localization is reportedly more frequent with unstabilized ^{99m}Tc -MDP products than with ^{99m}Tc -MDP products containing antioxidants (105).

At least four different complexes of ^{99m}Tc -MDP have been demonstrated by electrophoretic analysis of MDP kits from different manufacturers (106). One of these complexes results in accumulation of activity in the liver. Results of *in vitro* and *in vivo* studies have suggested that this liver localization is associated with methylphosphate, a degradation product formed from the hydrolysis of MDP (106). The results of further studies have suggested that variations in image quality obtained with different preparations of MDP may be associated with differences in kit formulation such as the MDP salt form, the ratio of stannous to MDP, and the presence of an antioxidant (107).

Alterations in biodistribution also occur with non- ^{99m}Tc -labeled radiopharmaceuticals obtained from different sources. [^{67}Ga]gallium citrate obtained from one manufacturer readily lo-

calizes in cerebral infarctions but does not localize when obtained from another manufacturer (108). This phenomenon may be related to differing citrate concentrations in the preparations (109).

Incompatibilities between radiopharmaceutical solutions and rubber-stoppered glass vials have also been reported. For example, significant differences in the stability of stannous chloride solutions have been observed in vials stoppered with different types of elastomeric closures (110). Similarly, significant differences in the adsorption of ^{99m}Tc -DMSA on the walls and stoppers of glass vials from different manufacturers have been observed with storage (111).

OXIDATION AND/OR RADIOLYTIC DECOMPOSITION

In the formulation of ^{99m}Tc -labeled radiopharmaceuticals, a variety of factors may produce detrimental effects on the initial labeling process and subsequent stability. Many of these factors are related to oxidation and radiolytic decomposition which lead to increased levels of free ^{99m}Tc -pertechnetate and/or ^{99m}Tc -labeled colloid impurities and subsequent image degradation.

In order for ^{99m}Tc to bind to most chelating reagents, it must be reduced from the +7 valence state of pertechnetate to a lower valence state. This reduction usually is accomplished by the stannous ion (Sn^{+2}) in the reagent kit. Sn^{+2} is readily oxidized by atmospheric oxygen to stannic ion (Sn^{+4}) which is no longer capable of reducing pertechnetate. Therefore, reagent solutions and lyophilized kits usually are purged with nitrogen and/or have nitrogen atmospheres in order to remove the atmospheric oxygen responsible for this oxidation (7, 28, 29, 32, 112). Furthermore, storage at refrigerator or freezer temperatures has been shown to inhibit the rate of oxidation (28). Trace amounts of oxygen may continue to produce this oxidation during manufacture and/or storage of reagent kits, especially if faulty vial seals allow the entrance of air (113). Formulation of such a product usually results in decreased labeling efficiency with increased free ^{99m}Tc -pertechnetate impurity.

Oxidizing agents present in $^{99}\text{Mo}/^{99m}\text{Tc}$ generator eluates also may interfere with the tech-

netium labeling process. Ionization of water in the generator column produces hydrogen peroxide (H_2O_2) and, in the presence of oxygen, hydroperoxy free radicals ($\cdot\text{HO}_2$) (9, 114). Both of these compounds are strong oxidizing agents and react with Sn^{+2} to produce Sn^{+4} . In some cases, the number of peroxide molecules added to a reagent kit may be of the same order of magnitude as the number of Sn^{+2} ions (9). Reports of decreased labeling efficiencies and increased free ^{99m}Tc -pertechnetate impurities are commonly associated with these larger-than-expected concentrations of peroxides and hydroperoxy radicals (9, 39, 115).

Of a similar nature is the report of poor labeling and rapid unbinding of ^{99m}Tc by iodinated antiseptics, with resultant ^{99m}Tc -pertechnetate impurity. Iodinated antiseptics are good oxidizing agents and, if inadvertently introduced into the vial after sterilization of the septum, may inhibit labeling with or may release previously bound ^{99m}Tc (116). With the use of alcohol rather than iodinated compounds for sterilization procedures, this effect can be avoided.

Oxidation of reduced and chelated ^{99m}Tc may also be associated with physical factors. For example, ultrasonic nebulization of ^{99m}Tc -DTPA for radioaerosol lung studies reportedly results in the liberation of $>50\%$ free pertechnetate (117). Thus, since ^{99m}Tc -pertechnetate and ^{99m}Tc -DTPA have different clearance rates from the lung, ultrasonic nebulization may result in variable, inconsistent lung studies.

Decomposition of radiopharmaceuticals is characterized by four mechanisms: internal radiation effects, direct radiation effects, indirect radiation effects, and nonradiolytic chemical effects (118). Of significance in radiopharmaceutical solutions are the indirect radiation effects resulting from the ionization of water which produces the strong oxidants, hydrogen peroxide and, in the presence of dissolved oxygen, hydroperoxy radicals (114, 119). Radiolytic decomposition is a function of total radioactivity content, since it is dose rate dependent rather than total dose dependent (33, 118). Decomposition of virtually all radiopharmaceuticals will occur if sufficient time is allowed; however, the rate of decomposition varies widely from one radiopharmaceutical to another and from

one formulation and/or storage factor to another (59, 120, 121). All radiopharmaceuticals should, therefore, be used as soon after preparation as possible to avoid radiolytic decomposition problems.

The stability of radiopharmaceuticals can be prolonged by a number of tactics that inhibit oxidation and/or radiolytic decomposition. Since dissolved oxygen promotes formation of hydroperoxy radicals, then minimizing the exposure of a radiopharmaceutical to the atmosphere, limiting introduction of air (especially bubbling) into the vial, and purging the solution with nitrogen help minimize oxidation and/or decomposition (31, 33, 34, 51, 56, 59, 122–125). Commercially available physiologic saline containing low dissolved oxygen is being promoted as offering beneficial effects on radiopharmaceutical labeling and stability. Routine use of low dissolved oxygen saline remains controversial, however, in light of recent data showing that the labeling efficiency and stability of ^{99m}Tc -gluceptate and the clinical performance of ^{99m}Tc -MDP were only minimally affected by the oxygen content of the saline used (126, 127). Excess stannous ion is effective for prolonging stability but may result in colloid formation if there is an overabundance of this ion (31–34). Perhaps more effective is the recent use of antioxidants (viz., ascorbic acid and gentisic acid) in ^{99m}Tc -labeled bone imaging agents, which have dramatically improved stability and image quality with storage over several hours (32, 34, 125, 128–132). It should be noted, however, that preparations stabilized with antioxidants may demonstrate higher levels of reduced-hydrolyzed technetium than do non-stabilized preparations (133). Oxidation and/or radiolytic decomposition proceeds at faster rates with increased temperatures; therefore, reducing the temperature by refrigeration may noticeably prolong the stability of most radiopharmaceuticals (53, 118, 134, 135). The addition of carrier, although seldom desired, may improve the stability of many radiopharmaceuticals (40, 118). Finally, because radiolytic decomposition is a function of total radioactivity content, more stability is achieved from formulation with the minimum desired radioactivity than is achieved from formulation with larger amounts of radioactivity (32, 119, 125, 127, 135).

SPECIFIC ACTIVITY

The specific activity of radiopharmaceuticals may have important effects on their biodistribution. The effects of lowered specific activity on radiopharmaceutical biodistribution are most pronounced when the localization of the agent demonstrates saturation pharmacokinetics. Saturation may occur whenever there are only a limited number of receptor sites, carriers, enzymes, or other interactive biological substances responsible for the localization (136). In these circumstances, carrier will compete with the specific radiopharmaceutical for these limited sites, and if saturation occurs, target-to-background radioactivity ratios will decrease.

A classic example of this phenomenon is the thyroid uptake of radioiodide. As little as 1 mg of carrier iodide may produce notable decreases in the 24-hour ^{131}I uptake (137), and doses of sodium iodide >10 mg suppress the 24-hour radioiodine uptake by 98% (138).

For the Schilling test, the amount of non-radioactive cyanocobalamin in the cyanocobalamin capsules has been shown to be critical. Amounts >2 μg appear to exceed the saturation level for intrinsic factor and may result in falsely low values for absorption and urinary excretion (139, 140). Increasing amounts of ^{99m}Tc -labeled sulfur colloid particles affect phagocytic localization, which results in a gradual decrease in liver uptake and an increase in bone marrow uptake (82). Likewise, the number of damaged radiolabeled RBC administered for a splenic sequestration study may be important in certain clinical situations in which overloading the sequestering ability of the spleen is possible (68). The presence of carrier markedly affects the biodistribution of ^{67}Ga -citrate by inhibiting localization in all usual (expected) organs except bone (141, 142).

Many of the newer and investigational radiopharmaceuticals are localized by mechanisms with limited capacities. Examples include carrier-mediated uptake of hepatobiliary agents (136), antibody-antigen interactions involving radiolabeled specific antibodies (143, 144), and hormone-receptor localization of radiolabeled hormone analogs (145, 146). In each of these cases, lowered specific activity results in decreased target-to-background radioactivity

ratios and inferior image quality. It should be noted, however, that in the presence of circulating antigen, a lower specific activity of radiolabeled antibodies is desired. If high specific activity and small amounts of total antibody are administered in this case, most of the radioactivity will be complexed to circulating antigen and cleared into the liver (147).

The distribution of some radiopharmaceuticals is relatively unaffected by specific activity. Carrier macroaggregated albumin does not affect the quality of lung perfusion images (95), a 10^6 -fold excess of carrier gluconate does not influence distribution of ^{99m}Tc -gluconate (4), and a 10^5 -fold excess of carrier HEDP does not significantly change ^{99m}Tc -HEDP distribution (4).

SOLUBILITY

The solubility of ^{99m}Tc -labeled radiopharmaceuticals in a suitable media for intravenous administration usually does not present a severe problem, because of the polar hydrophilic nature of most of these agents. Some radiopharmaceuticals (e.g., radiolabeled cholesterols, amino acids, fatty acids), however, are insoluble in water at physiological pH values, and their formulation is problematic. A common problem encountered with use of these latter agents is incomplete or unstable solubilization leading to increased RES and/or lung localization as a result of colloid and/or particulate formation (148). Based on toxicity considerations (see Chapter 20), the requirement for intravenous administration of most radiopharmaceuticals limits the choice of surfactants available for solubilization of agents (149, 150). Recent evidence supports the use of hydroalcohol human serum albumin solutions (151) and the relatively nontoxic poly(oxypropylene)poly(oxyethylene) condensates (Pluronic) for this purpose (152).

PRESERVATIVES

Since sterility of products for parenteral administration is essential, one might surmise that bacteriostatic saline would be used in the preparation of injectable radiopharmaceuticals. Unfortunately, bacteriostatic saline may have serious deleterious effects on many ^{99m}Tc -labeled radiopharmaceuticals. Most of these effects can

be traced to reactions with benzyl alcohol, the most commonly used active agent in bacteriostatic saline.

When bacteriostatic saline is used to elute a $^{99}\text{Mo}/^{99m}\text{Tc}$ generator, up to 99% of the ^{99m}Tc activity may be retained on the generator column (153). It is theorized that the benzyl alcohol in the bacteriostatic saline may be transformed by radiolytic oxidation to benzaldehyde, a weak reducing agent. One or both of these species may then reduce the ^{99m}Tc -pertechnetate in situ to an insoluble form which is retained on the column.

Bacteriostatic saline used in the preparation of ^{99m}Tc -labeled radiopharmaceuticals may adversely effect the radiochemical purity, stability, and biodistribution. ^{99m}Tc -pertechnetate dissolved in bacteriostatic saline demonstrates a significant increase in the percentage of ^{99m}Tc -labeled colloid impurities. ^{99m}Tc -MDP prepared with bacteriostatic saline exhibits significantly more free ^{99m}Tc -pertechnetate impurity, faster rate of decomposition, and higher blood, muscle, and liver background activity than does ^{99m}Tc -MDP prepared with preservative-free saline (153). Because of these potential deleterious effects, only preservative-free saline should be used in the preparation of ^{99m}Tc -labeled radiopharmaceuticals.

Benzyl alcohol is of limited applicability for two additional reasons. First, it is a vasodilator and, therefore, cannot be used with a reagent such as ^{133}Xe in saline solution intended for regional blood flow measurements. Second, it undergoes radiation decomposition with the production of a precipitate (presumably benzoic acid) in certain solutions of high radioactive concentrations (154).

ANTICOAGULANTS

The in vitro labeling of RBC for subsequent reinjection requires that the blood sample be fully anticoagulated. Unfortunately, the presence of an anticoagulant, usually heparin or acid-citrate-dextrose (ACD), may affect the labeling and/or biodistribution of the labeled RBC. For example, RBC labeled with ^{99m}Tc in the presence of heparin show a lower labeling efficiency, more extravascular activity, and more urinary excretion than do those labeled in ACD (8). Excess ACD, however, causes damage

to RBC, with resultant sequestration in the spleen (155).

ENCAPSULATION

Encapsulation of radiopharmaceutical doses for oral administration has gained widespread acceptance as a convenient method for the handling, dispensing, and administering of certain radioactive compounds. The use of encapsulated radiopharmaceuticals presupposes that the capsule will rapidly disintegrate and its contents dissolve in the stomach fluids and that the radiopharmaceutical will not interact with the capsular materials. Some evidence has suggested that the aforementioned assumptions are not valid and that this oral dosage form may alter the biodistribution of the radiopharmaceutical.

The possibility of residual ^{131}I contained in some undissolved capsule was suggested as the cause of right-lower-quadrant activity reported in a patient administered encapsulated sodium ^{131}I iodide (156). Subsequent studies of the effect of encapsulation on the thyroid uptake of ^{131}I demonstrated substantially lower uptakes with ^{131}I capsules than with ^{131}I oral solution (156). Proposed mechanisms for this effect include delayed dissolution and absorption of the radioiodine, formation of nonabsorbable iodine complex with capsular material, and/or absorption of radioiodinated gelatin. A situation has also been reported in which the presence of β -naphthol, a bacteriostatic agent in the ^{131}I capsule, resulted in the formation of iodinated β -naphthol (157). This effect is most serious when it may alter the interpretation of a radioactive iodine uptake study or produce visualization of abdominal activity. With the recent development of a new ^{131}I capsule formulation, however, it is reported that the aqueous radioiodination of gelatin can be prevented by suspending the radioiodine within a polyethylene glycol base (158). Furthermore, rapid dissolution of the polyethylene glycol base in gastric fluid allows bioavailability equal to that from oral solutions (158).

Encapsulated cyano ^{57}Co cobalamin, compared with cyano ^{57}Co cobalamin solution, has been shown to result in significantly decreased absorption and urinary excretion when admin-

istered for Schilling tests (159). The difference in drug availability between the capsule and the solution is probably due to both the speed of capsule dissolution and the passage of the capsule mass from the stomach to the duodenum. Since falsely low urinary excretion values obtained with the encapsulated material may result in a false interpretation of pernicious anemia, a liquid dosage form is recommended (159).

The interpretation of second-stage Schilling tests may be altered by the administration of encapsulated doses. The coadministration of encapsulated intrinsic factor, compared with the administration of a solution of intrinsic factor premixed with cyano ^{57}Co cobalamin, has been shown to result in significantly decreased urinary excretion (160). The difference in urinary excretion between the two forms of administration may be due to prolonged capsule dissolution, biological inactivity of some commercial intrinsic-factor preparations, and/or the binding of intrinsic factor to blocking antibodies in the gastric juice (160–162). Since falsely low urinary excretion values obtained with encapsulated intrinsic factor may result in a false interpretation of intestinal malabsorption, intrinsic factor and cyano ^{57}Co cobalamin should be mixed together in water prior to administration (160–162).

ISOTOPE EXCHANGE

The dual-isotope (Dicopac) Schilling test allows simultaneous performance of first- and second-stage Schilling tests for the diagnosis of pernicious anemia or intestinal malabsorption syndrome. Unlike the traditional Schilling test, the dual-isotope procedure employs the coadministration of cyano ^{58}Co cobalamin and cyano ^{57}Co cobalamin bound to human intrinsic factor. Experience, however, has indicated a disturbingly high frequency (17–46%) of spurious results with use of the dual-isotope method (163–165). These misleading results are probably due to rapid or variable rates of exchange of bound and free cyanocobalamin on the intrinsic factor molecule (165, 166). The exchange is especially striking at an acidic pH at which equimolar equilibrium may be achieved within 10 minutes in simulated gastric juice (165). In

order to obviate the effect of exchange reactions, it may be desirable to perform the traditional Schilling test in most cases (165).

IODINE VOLATILITY

Inhalation of volatilized radioiodine is a major problem associated with the handling and administration of sodium ^{131}I iodide oral solutions. Airborne ^{131}I activity in excess of maximum permissible concentrations has been reported with the handling of therapeutic amounts of ^{131}I and the administration of such doses (167, 168). Furthermore, the thyroid glands of the personnel handling these doses may be exposed to substantial radiation by the accumulation of ^{131}I (167–172).

The iodide ion in sodium ^{131}I iodide solutions is easily oxidized to iodine by dissolved oxygen in an acidic solution (173, 174). The presence of oxygen can occur from exposure to air (174) and/or oxygen generation by the radiolysis of water (171). Hydrogen ions can be present from acid formulation of the solution (168) and/or from reactions accompanying the dissolution of carbon dioxide in water (174). The iodine thus formed is not very soluble in water and rapidly volatilizes out of solution (174).

The rate of volatility is influenced by a variety of factors, and a number of methods that diminish this rate have been developed. The most important factor is that of pH. The use of buffers to maintain an alkaline pH has resulted in significantly lowered volatility rates and decreased thyroid accumulation, as compared with acidic formulations (168–170, 172, 175).

Several other formulation methods also focus on the oxidation reaction. Addition of an antioxidant such as sodium bisulfite or thiosulfate to the formulation helps to inhibit the oxidation of iodide to volatile forms of iodine (158, 168, 174, 175). Inclusion of a chelating agent such as disodium edetate prevents catalytic oxidative reactions by metal ions (168, 175), and the use of distilled water as a diluent circumvents the problem of iodide oxidation by chlorine in tap water (171). Storing and handling the solution at room temperature or below helps inhibit the heat catalysis of the oxidation reaction (174) and

reduces the vapor pressure of volatile iodine (176).

One last formulation method for reducing volatility of ^{131}I is encapsulation of the radioiodide. ^{131}I diagnostic and therapeutic capsules have been shown to produce negligible airborne radioactivity, probably because many oxidation factors are eliminated and/or the iodine may be absorbed by the capsular material (158, 167).

RADIONUCLIDIC CONTAMINATION

Several radiopharmaceuticals contain radionuclidic impurities in large enough quantities to be of concern. Especially susceptible to the production of radionuclidic contaminants are those radioisotopes produced in a cyclotron. Another possible cause of significant radionuclidic contamination is parent breakthrough in a generator eluate. $^{99\text{m}}\text{Mo}$ contamination of $^{99\text{m}}\text{Tc}$ products is negligible, however, since it is limited to 0.015% for administration to patients (177).

One of the most important concerns is the increase in radiation-absorbed dose from the radionuclidic impurities. For example, the radiation-absorbed doses to the thyroid and the whole body from radioiodide impurities, e.g., ^{124}I in some ^{123}I products, approach, and may even exceed, the doses from the principal radioisotope (178).

Another concern is the potential errors in dose calibration. Since an ionization chamber does not have intrinsic energy discrimination capability, the presence of radionuclidic impurities will affect the reading of the instrument (179). For example, the presence of radioiodide impurities in some ^{123}I products has been shown to significantly increase dose calibrator readings (180, 181). Similarly, the presence of radioiodide impurities in some ^{123}I products can introduce substantial errors in radioactive iodine uptake (RAIU) measurements, especially if the probe counter is used in the integral mode (181–183).

Of paramount concern clinically is image degradation caused by Compton scatter and septal penetration of high-energy photons emitted by radionuclidic impurities. Significant image degradation has been observed with the use of

^{123}I products containing ^{124}I and other radioiodide contaminants (178, 184–186) and with the use of ^{201}Tl products containing ^{200}Tl and/or ^{202}Tl contaminants (187, 188). For example, Ricciardone et al. (189) have observed problems in cases in which [^{201}Tl]thallous chloride was used more than 3 days prior to the date of calibration. Specifically, at 4 days precalibration, the radionuclidic contaminant ^{200}Tl (which has a shorter physical half-life than does ^{201}Tl) may be present at levels that cause image degradation.

Radionuclidic impurities often have longer half-lives than do the principal radionuclide (e.g., ^{124}I , ^{202}Tl). Thus, the percentage of radionuclidic contamination continuously increases with time. Increases in radiation dose, errors in dose calibration and activity measurement, and image degradation, therefore, become more pronounced as the time of use approaches the expiration time.

REFERENCES

- Lamson ML, Kirschner AS, Hotte C, et al: Generator-produced $^{99m}\text{TcO}_4^-$: carrier-free? *J Nucl Med* 16:639–641, 1975.
- Molter M: The current status of ^{99m}Tc generators. *Nuklearmedizin* 20:7–10, 1981.
- Albers JW, Jenkins D, Sandee RJ, et al: Free (unreacted) pertechnetate in technetium-sulfur colloid preparations. *J Nucl Med Technol* 2:14–17, 1974.
- Hambricht P, McRae J, Valk PE, et al: Chemistry of technetium radiopharmaceuticals. I. Exploration of the tissue distribution and oxidation state consequences of technetium (IV) in Tc-Sn-gluconate and Tc-Sn-EHDP using carrier ^{99}Tc . *J Nucl Med* 16:478–482, 1975.
- Porter WC, Dworkin HJ, Gutkowski RF: The effect of carrier technetium in the preparation of ^{99m}Tc human serum albumin. *J Nucl Med* 17:704–706, 1976.
- Smith TD, Steimers JR, Richards P: Chemical effect of ^{99}Tc on ^{99m}Tc labeled radiopharmaceuticals. *J Nucl Med* 16:570–571, 1975.
- Smith TD, Richards P: A simple kit for the preparation of ^{99m}Tc -labeled red blood cells. *J Nucl Med* 17:126–131, 1976.
- Porter WC, Dees SM, Freitas JE, et al: Acid-citrate-dextrose compared with heparin in the preparation of *in vivo/in vitro* technetium-99m red blood cells. *J Nucl Med* 24:383–387, 1983.
- Colombetti LG, Barnes WE: Effect of chemical and radiochemical impurities from eluants on ^{99m}Tc -labeling efficiency. *Nuklearmedizin* 16:271–274, 1977.
- Van Duzec BF, Bugaj JE: The effect of total technetium concentration on the performance of a skeletal imaging agent. *Clin Nucl Med* 6 (Suppl):P148, 1981.
- Bell EG, McAfee JG, Subramanian G: Radiopharmaceuticals in pediatrics. In James AE, et al (eds): *Pediatric Nuclear Medicine*. Philadelphia, WB Saunders, 1974, pp 84–94.
- Dworkin HJ, Nelis A, Dowse L: Rectilinear liver scanning with technetium-99m sulfide colloid. *Am J Roentgenol Rad Ther* 101:557–560, 1967.
- Weinstein MB, Smoak W: The author's reply. *J Nucl Med* 11:767–768, 1970.
- Larson SM, Nelp WB: Radiopharmacology of a simplified technetium-99m colloid preparation for photoscanning. *J Nucl Med* 7:817–826, 1966.
- Rhodes BA, Croft BY: *Basics of Radiopharmacy*. St Louis, CV Mosby, 1978, p 142.
- United States Pharmacopeial Convention: Sodium pertechnetate ^{99m}Tc injection. In: *The United States Pharmacopeia & National Formulary*. Rockville, MD, United States Pharmacopeial Convention, 1984, pp 1016–1017.
- Haney TA, Ascanio I, Gigliotti JA, et al: Physical and biological properties of a ^{99m}Tc -sulfur colloid preparation containing disodium edetate. *J Nucl Med* 12:64–68, 1971.
- Staum MM: Incompatibility of phosphate buffer in ^{99m}Tc -sulfur colloid containing aluminum ion. *J Nucl Med* 13:386–387, 1972.
- Study KT, Hladik WB, Saha GB: Effects of Al^{+3} ion on ^{99m}Tc sulfur colloid preparations with different buffers. *J Nucl Med Technol* 12:16–18, 1984.
- Bobinet DD, Sevrin R, Zurbriggen MT, et al: Lung uptake of ^{99m}Tc -sulfur colloid in patient exhibiting presence of Al^{+3} in plasma. *J Nucl Med* 15:1220–1222, 1974.
- Miller W: Technetium-99m biorouting. In Early PJ, et al (eds): *Textbook of Nuclear Medicine Technology*, ed 3. St Louis, CV Mosby, 1979, pp 544–570.
- Zimmer AM, Pavel DG: Experimental investigations of the possible cause of liver appearance during bone scanning. *Radiology* 126:813–816, 1978.
- Chaudhuri TK: Liver uptake of ^{99m}Tc -diphosphonate. *Radiology* 119:485–486, 1976.
- Chaudhuri TK: The effect of aluminum and pH on altered body distribution of ^{99m}Tc -EHDP. *Int J Nucl Med Biol* 3:37–40, 1976.
- Wang TST, Fawwaz RA, Esser PD, et al: Altered body distribution of [^{99m}Tc] pertechnetate in iatrogenic hyperalbuminemia. *J Nucl Med* 19:381–383, 1978.
- Shukla, SK, Manni GB, Cipriani C: Effect of aluminum impurities in the generator-produced pertechnetate-99m ion on thyroid scintigrams. *Eur J Nucl Med* 2:137–141, 1977.
- Lin MS, MacGregor RD, Yano Y: Ionic aluminum (III) in generator eluate as an erythrocyte-agglutinating agent. *J Nucl Med* 12:297–299, 1971.
- McBride MHD, Shaw SM, Kessler WV: Deterioration of stannous ion in radiopharmaceutical kits during storage. *Am J Hosp Pharm* 36:1370–1372, 1979.
- Owunwanne A, Church LB, Blau M: Effect of oxygen on the reduction of pertechnetate by stannous ion. *J Nucl Med* 18:822–826, 1977.
- Majewski W, Zimmer AM, Spies SM: Stannous-tin levels in commercial stannous pyrophosphate: effect of altering preparation methods. *J Nucl Med Technol* 9:116, 1981.
- Kowalsky RJ, Dalton DR: Technical problems associated with the production of technetium ^{99m}Tc tin (II) pyrophosphate kits. *Am J Hosp Pharm* 38:1722–1726, 1981.
- Francis MD, Tofe AJ, Hiles RA, et al: Inorganic tin: chemistry, disposition and role in nuclear medicine diagnostic skeletal imaging agents. *Int J Nucl Med Biol* 8:145–152, 1981.
- Billingham MW, Rempel S, Westendorf BA: Radiation decomposition of ^{99m}Tc radiopharmaceuticals. *J Nucl Med* 20:138–143, 1979.
- Tofe AJ, Bevan JA, Fawzi MB, et al: Antioxidant stabilization of bone agents. In Sodd VJ, Hoogland DR, Allen DR, et al: *Radiopharmaceuticals II*. New York, Society of Nuclear Medicine, 1979, pp 637–644.
- Bardy A, Fouye H, Gobin R, et al: Technetium-99m labeling by means of stannous pyrophosphate: application to bleomycin and red blood cells. *J Nucl Med* 16:435–437, 1975.
- Zimmer AM: In vitro technetium-99m red blood cell labeling using commercial stannous pyrophosphate. *Am J Hosp Pharm* 34:264–267, 1977.
- Callahan RJ, Froelich JW, McKusick KA, et al: Factors affecting the rate and extent of incorporation of ^{99m}Tc into pre-tinned red blood cells (RBC). *J Nucl Med* 23:P109, 1982.
- Zanelli GD: Effect of certain drugs used in the treatment of cardiovascular disease on the "in vitro" labeling of red blood cells with ^{99m}Tc . *Nucl Med Commun* 3:155–161, 1982.
- Lin MS, Winchell S, Shipley BA: Use of Fe(II) or Sn(II) alone for technetium labeling of albumin. *J Nucl Med* 12:204–211, 1971.
- Chi SL, Hoag SG, Yanchick VA: Electrolytic complexing of glucoheptonate and technetium-99m. *J Nucl Med* 19:520–524, 1978.
- Kelly WN, Ice RD: Pharmaceutical quality of technetium-99m sulfur colloid. *Am J Hosp Pharm* 30:817–820, 1973.
- Harper PV, Lathrop KA, Gottschalk A: Pharmacodynamics of some technetium-99m preparations. In Andrews GA, et al (eds): *Radioactive Pharmaceuticals*. Oak Ridge, TN, US Atomic Energy Commission, 1966, pp 67–91.
- Nunn AD, Schramm E: Analysis of Tc-HIDAs and factors affecting their labeling rate, purity, and stability. *J Nucl Med* 22:P52, 1981.
- Subramanian G, McAfee JG: Stannous oxide colloid labeled with ^{99m}Tc or ^{113m}In for bone marrow imaging. *J Nucl Med* 11:365–366, 1970.
- Schumichen C, Walden J, Hoffman G: Kinetics of various ^{99m}Tc -Sn-pyrophosphate compounds in the rat. I. In vivo studies. *Nuklearmedizin* 16:100–103, 1977.
- Schumichen C, Mackenbrock B, Hoffman G: Kinetics of various ^{99m}Tc -Sn-pyrophosphate compounds in the rat. II. In vitro studies. *Nuklearmedizin* 16:157–162, 1977.
- Hoogland DR, Forstrom LA, Mahdal AF, et al: Effects of pH on tissue distribution of ^{99m}Tc -pyrophosphate (PYP) in bone imaging. *Med Imaging* 2:39, 1977.
- Russell CD, Cash AG: Oxidation state of technetium in bone scanning agents. In Sodd VJ, Hoogland DR, Allen DR, et al: *Radiopharmaceuticals II*. New York, Society of Nuclear Medicine, 1979, pp 627–636.
- Libson K, Deutsch E, Heineman WR, et al: Preparative control, HPLC analysis, and in vivo evaluation of components of a technetium-MDP radiopharmaceutical mixture. *J Nucl Med* 24:P23, 1983.
- Tanabe S, Zozda JP, Deutsch E, et al: Effect of pH on the formation of $\text{Tc}(\text{NaBH}_4)$ -MDP radiopharmaceutical analogues. *Int J Appl Radiat Isot* 34:1577–1584, 1983.
- Krejcarek GE, Wicks JH, Heerwald PE, et al: The structure of stannous dimercaptosuccinic acid chelates. *J Nucl Med* 17:565, 1976.
- Krejcarek GE, Heerwald PE, Tucker KL, et al: The chemistry of stannous dimercaptosuccinic acid chelates. *J Labelled Compd Radiopharm* 13:157, 1977.
- Ikeda I, Inoue O, Kurata K: Preparation of various ^{99m}Tc dimercaptosuccinate complexes and their evaluation as radiotracers. *J Nucl Med* 18:1222–1229, 1977.
- Hata N, Yokohama A, Horiuchi K, et al: New $^{99m}\text{Tc}(\text{V})$ DMSA tumor imaging radiopharmaceuticals, with distinctive behavior from renal ^{99m}Tc -DMSA. *J Nucl Med* 24:P126–P127, 1983.
- Fritzberg AR, Lewis D: HPLC analysis of ^{99m}Tc iminodiacetate hepatobiliary agents and a question of multiple peaks: concise communication. *J Nucl Med* 21:1180–1184, 1980.
- Yano Y, McRae J, Van Dyke DC, et al: Technetium-99m-labeled stannous ethane-1-hydroxy-1, 1-diphosphonate: a new bone scanning agent. *J Nucl Med* 14:73–78, 1973.
- Levit N: Concentrated technetium and its effects on tagging efficiency. *Monthly Scan* p 1, November 1979.
- Feezer B: Clinical manifestation of a radiopharmaceutical formulation problem. *Monthly Scan* pp 1–2, March 1979.
- Sampson CB, Keegan J: Stability of ^{99m}Tc -DTPA injection: effect of delay after preparation, dilution, generator oxidant, air and oxygen. *Nucl Med Commun* 6:313–318, 1985.
- Inoue O, Ikeda I, Kurata K: Evaluation of two different HEDP content kits: stability study against dilution both in vivo and in vitro. *Nuklearmedizin* 21:121–125, 1982.
- Fortman DL, Sodd VJ: ^{99m}Tc -sulfur colloid—evaluation of preparation parameters for kits from four commercial manufacturers. In Sodd VJ, Hoogland DR, Allen DR, et al: *Radiopharmaceuticals II*. New York, Society of Nuclear Medicine, 1979, pp 15–23.

62. Early PJ, Razzak MA, Sodee DB: *Textbook of Nuclear Medicine Technology*, ed 3. St Louis CV Mosby, 1979, pp 363-370.
63. Som P, Ansari AN, Oster ZH, et al: Effects of heating on the size-distribution and differential uptake of ^{99m}Tc -red blood cells (RBC) by spleen and liver. *J Nucl Med* 21:P44, 1980.
64. Som P, Oster ZH, Atkins HL, et al: Detection of gastrointestinal blood loss with ^{99m}Tc -labeled, heat-treated red blood cells. *Radiology* 138:207-209, 1981.
65. Frier M, Griffiths P, Ramsey A: The physical and chemical characteristics of sulphur colloids. *Eur J Nucl Med* 6:255-260, 1981.
66. Som P, Oster ZH: Spleen scanning with ^{99m}Tc -labeled red blood cells (RBC). *J Nucl Med* 21:1000, 1980.
67. Gotschalk A, Armas R, Thakur ML: Spleen scanning with ^{99m}Tc -labeled red blood cells (RBC). Reply. *J Nucl Med* 21:1000-1001, 1980.
68. Atkins HL, Goldman AG, Fairchild RG, et al: Splenic sequestration of ^{99m}Tc labeled, heat treated red blood cells. *Radiology* 136:501-503, 1980.
69. Valk PE, Guille J: Measurement of splenic function with heat-damaged RBCs: effect of heating conditions: concise communication. *J Nucl Med* 25:965-968, 1984.
70. Ponto JA, Ponto LLB: Time dependence of PIPIDA-labeling with ^{99m}Tc . *Am J Hosp Pharm* 38:1939-1941, 1981.
71. Froelich JW, Callahan RJ, Leppo J, et al: Time course of in vivo labelling of red blood cells. *J Nucl Med* 21:P44, 1980.
72. Callahan RJ, Froelich JW, McKusick KA, et al: Studies of red blood cell (RBC) labeling: rate of binding of ^{99m}Tc to hemoglobin (Hgb) in the intact cell and Hgb solution. *J Nucl Med* 22:P70, 1981.
73. Callahan RJ, Froelich JW, McKusick KA, et al: A modified method for the in vivo labeling of red blood cells with ^{99m}Tc . Concise communication. *J Nucl Med* 23:315-318, 1982.
74. Boudreau R, Rosenthal L, Tyler JL, et al: Effect of ^{99m}Tc -Sn-colloid incubation time on in vivo distribution. *Eur J Nucl Med* 8:335-337, 1983.
75. Henkin RE, Woodruff A, Chang W, et al: The effect of radiopharmaceutical incubation time on bone scan quality. *Radiology* 135:463-466, 1980.
76. Buell U, Kleinhaus E, Zorn-Bopp E, et al: A comparison of bone imaging with ^{99m}Tc DPD and ^{99m}Tc MDP: concise communication. *J Nucl Med* 23:214-217, 1982.
77. Wilson MA, Pollack MJ: Gastric visualization and image quality in radionuclide bone scanning: concise communication. *J Nucl Med* 22:518-521, 1981.
78. Van Duzee BF, DePrato DW, Cavanaugh DJ, et al: A multi-site clinical study of factors influencing soft-tissue localization of skeletal imaging agents in children. *J Nucl Med* 23:P99, 1982.
79. Van Duzee BF, Conway JJ, Cavanaugh DJ, et al: Radiopharmaceutical preparation conditions associated with abnormal soft-tissue localization of skeletal imaging agents. *Pharm Pract* 18:A-11, 1983.
80. McLean JR, Wise P: Impurities in a ^{99m}Tc lung imaging kit. *J Nucl Med Technol* 5:28-31, 1977.
81. McLean JR, Welsh WJ, Rockwell LJ: Quality control procedures for ^{99m}Tc -MAA. *Int J Nucl Med Biol* 6:142-143, 1979.
82. Atkins HL, Hauser W, Richards P: Factors affecting distribution of ^{99m}Tc -sulfur colloid. *J Nucl Med* 10:319-320, 1969.
83. Davis MA, Jones AG, Trindade H: A rapid and accurate method for sizing radiocolloids. *J Nucl Med* 15:923-928, 1974.
84. Heyman S, Davis MA, Shulkin PM, et al: Biologic evaluation of radiocolloids for bone marrow scintigraphy. In Sodd VJ, Hoogland DR, Allen DR, et al: *Radiopharmaceuticals II*. New York, Society of Nuclear Medicine, 1979, pp 593-601.
85. Martindale AA, Papadimitriou JM, Turner JH: Technetium-99m antimony colloid for bone marrow imaging. *J Nucl Med* 21:1035-1041, 1980.
86. Kloiber R, Damew B, Rosenthal L: A crossover study comparing the effect of particle size on the distribution of radiocolloid in patients. *Clin Nucl Med* 6:204-206, 1981.
87. Adams FG, Horton PW, Selim SM: Clinical comparison of three liver scanning agents. *Eur J Nucl Med* 5:237-239, 1980.
88. Spencer RP: Role of radiolabeled erythrocyte in evaluation of splenic function. *J Nucl Med* 21:489-491, 1980.
89. Campbell J, Bellen JC, Baker RJ, et al: Technetium-99m calcium phytate—optimization of calcium content for liver and spleen scintigraphy: concise communication. *J Nucl Med* 22:157-160, 1981.
90. Davis MA: Particulate radiopharmaceuticals for pulmonary studies. In Subramanian G, et al (eds): *Radiopharmaceuticals*. New York, Society of Nuclear Medicine, 1975, pp 267-281.
91. Rhodes BA, Croft BY: *Basics of Radiopharmacy*. St Louis, CV Mosby, 1978:142-144.
92. Pedersen B, Kristensen K: Evaluation of methods for sizing of colloidal radiopharmaceuticals. *Eur J Nucl Med* 6:521-526, 1981.
93. Strout B, Hladik WB: Tc-MAA: focal hot spots. *Monthly Scan* pp 1-2, December 1978.
94. Heck LL, Duley JW: Statistical considerations in lung imaging with ^{99m}Tc albumin particles. *Radiology* 113:675-679, 1974.
95. Dworkin HJ, Gutkowski RF, Porter W, et al: Effect of particle number on lung perfusion images: concise communication. *J Nucl Med* 18:260-262, 1977.
96. Cohen MB, Spolter L: Effect of stabilizers and autoclaving in the preparation of ^{99m}Tc -sulfur colloid. *J Nucl Med* 10:395-396, 1969.
97. Porter WC, Dworkin HJ, Gutkowski RF: Vial retention of ^{99m}Tc sulfur colloid in commercial kits. *Am J Hosp Pharm* 32:1141-1143, 1975.
98. Yano Y: Radionuclide generators: current and future applications in nuclear medicine. In Subramanian G, et al (eds): *Radiopharmaceuticals*. New York, Society of Nuclear Medicine, 1975, pp 236-245.
99. Conway JJ, Weiss S, Van Duzee BF, et al: A comparative study of the effects of instant and generator produced technetium 99m on the nonosseous localization of skeletal imaging agents in children. *J Nucl Med* 23:P109, 1982.
100. Nusynowitz ML, Straw JD, Benedetto AR, et al: Blood clearance rates of technetium-99m albumin preparations: concise communication. *J Nucl Med* 19:1142-1145, 1978.
101. Atkins HL, Cardinale KG, Eckelman WC, et al: Evaluation of ^{99m}Tc -DTPA prepared by three different methods. *Radiology* 98:674-677, 1971.
102. Carlsen JE, Moller ML, Lund JO, et al: Comparison of four commercial ^{99m}Tc (Sn)DTPA preparations used for the measurement of glomerular filtration rate: concise communication. *J Nucl Med* 21:126-129, 1980.
103. Russell CD, Bischoff PG, Rowell KL, et al: Quality control of ^{99m}Tc -DTPA for measurement of glomerular filtration: concise communication. *J Nucl Med* 24:722-727, 1983.
104. Vanlic-Razumenic N: Comparative examinations of ^{99m}Tc -DMS preparations obtained by labelling dimercaptosuccinate kits with different formulations. II. Comparison of chemical and biological characteristics of Tc-P-5 and MPI kits. *Nuclearmedizin* 20:46-49, 1981.
105. Fordham EW, Ali A, Turner DA, et al: *Atlas of Total Body Radionuclide Imaging*. Philadelphia, Harper & Row, vol II, 1982, pp 1587-1667.
106. Najafi A, Hutchison N: Electrophoretic analysis of different technetium-99m(SnCl₂) methylene diphosphonate complexes. *J Nucl Med* 26:524-530, 1985.
107. SeEVERS RH, Apodaca DM, Ryo UY, et al: Variations in quality of bone images obtained with four different preparations of MDP. *J Nucl Med* 26:P130, 1985.
108. Waxman AD, Siemsen JK, Lee GC, et al: Reliability of gallium brain scanning in the detection and differentiation of central nervous system lesions. *Radiology* 116:675-678, 1975.
109. Hnatowich DJ, Kulprathipanja S, Beh B: The effect of preparation quality on biodistribution of ^{67}Ga citrate. *J Labelled Compd Radiopharm* 13:180, 1977.
110. Petry NA, Shaw SM, Kessler WV, et al: Effect of rubber closures on the stability of stannous ion in reagent kits for radiopharmaceuticals. *J Parent Drug Assoc* 33:283-286, 1979.
111. Millar AM: The absorption of ^{99m}Tc dimercaptosuccinic acid onto injection vials. *Nucl Med Commun* 5:195-199, 1984.
112. Kowalsky RJ, Chilton HM: Re: stability of stannous ion in stannous pyrophosphate kits. *J Nucl Med* 24:1080-1081, 1983.
113. McKusick KA, Malmud LS, Kirchner PT, et al: An interesting artifact in radionuclide imaging of the kidneys. *J Nucl Med* 14:113-114, 1973.
114. Thornton AK, Molinski VJ, Spencer JT: Radiolytic production of peroxides in technetium-99m solutions. *J Nucl Med* 20:653, 1979.
115. Robins PJ, Williams CC: An investigation of low tagging yields of ^{99m}Tc DTPA kits. *J Nucl Med* 20:653, 1979.
116. Fisher SM, Brown RG, Greyson ND: Unbinding of ^{99m}Tc by iodinated antiseptics. *J Nucl Med* 18:1139-1140, 1977.
117. Waldman DL, Weber DA, Oberdorster G, et al: Chemical breakdown of radioaerosols during nebulization. *J Nucl Med* 26:P131, 1985.
118. Hotte CE, Ice RD: The in vitro stability of [¹³¹I]iodohippurate. *J Nucl Med* 20:441-447, 1979.
119. Der M, Ballinger JR, Bowen BM: Decomposition of ^{99m}Tc pyrophosphate by peroxides in pertechnetate used in preparation. *J Nucl Med* 22:645-646, 1981.
120. Zimmer AM, Spies SM: Quality control of unit-dose dispensed radiopharmaceuticals: correlation to vial preparations. *Pharm Pract* 17:A-17, 1982.
121. Sampson CB: Instability of commercial ^{99m}Tc -DTPA kits—effect of dilution and delay before injection. *Nucl Med Commun* 5:239, 1984.
122. Dhawan V, Yeh DJ: Labeling efficiency and stomach concentration in methylene diphosphonate bone imaging. *J Nucl Med* 20:791-793, 1979.
123. Taylor A, Lallone RL, Hagan PL: Optimal handling of dimercaptosuccinic acid for quantitative renal scanning. *J Nucl Med* 21:1190-1192, 1980.
124. Jovanovic V, Konstantinovska D, Memedovic T: Determination of radiochemical purity and stability of ^{99m}Tc -diethyl HIDA. *Eur J Nucl Med* 6:375-378, 1981.
125. Beightol RW, Cochrane J: Radiochemical analysis of commercial MDP bone kits. *J Nucl Med Technol* 11:173-176, 1983.
126. Coupal JJ, Kim EE, DeLand FH: Effects of dissolved oxygen on ^{99m}Tc methylene diphosphonate: concise communication. *J Nucl Med* 22:153-156, 1981.
127. Zbrzezny DJ, Khan RAA: Factors affecting the labeling efficiency and stability of technetium-99m-labeled glucoheptonate. *Am J Hosp Pharm* 38:1499-1502, 1981.
128. McCormick MV, Sinclair MD, Wahner HW: Chromatographic quality of three ^{99m}Tc bone-imaging agents. *J Nucl Med Technol* 4:189-192, 1976.
129. Zimmer AM, Pavel DG: Radiochemical evaluation and image correlation of stabilized and non-stabilized ^{99m}Tc -Sn-diphosphonate kits. *J Nucl Med Technol* 5:54-55, 1977.
130. Tofe AJ, Bevan JA, Fawzi MD, et al: Gentisic acid: a new stabilizer for low tin skeletal imaging agents: concise communication. *J Nucl Med* 21:366-370, 1980.
131. Hesselwood SR: Quality control procedures for ^{99m}Tc complexes. *Nuclearmedizin* 20:3-6, 1981.
132. Ballinger J, Der M, Bowen B: Stabilization of ^{99m}Tc -pyrophosphate injection with gentisic acid. *Eur J Nucl Med* 6:153-154, 1981.
133. Collins HR, Kavula M, Solomon AC: Stability of unit-dose technetium-99m radiopharmaceuticals: radiochemical purity of multidose syringe. *Pharm Pract* 18:A-12, 1983.
134. Glenn HJ, Kidwell RE: Radioactive pharmaceuticals and the concept of stability. In Andrews GA, et al (eds): *Radioactive Pharmaceuticals*. Oak Ridge, TN, US Atomic Energy Commission, 1966, pp 165-175.
135. Porter WC, Grotenhuis I: ^{99m}Tc Sn glucoheptonate: a

- professional dialogue. *Monthly Scan* p 1, September 1978.
136. Loberg M: The study of organ function using radiolabeled drugs. Presented at the 128th Annual Meeting of the American Pharmaceutical Association. March 30, 1981, St Louis, MO.
 137. Grayson RR: Factors which influence the radioactive iodine thyroidal uptake test. *Am J Med* 28:397-415, 1960.
 138. Sternthal E, Lipworth L, Stanley B, et al: Suppression of thyroid radioiodine uptake by various doses of stable iodine. *N Engl J Med* 303:1083-1088, 1980.
 139. Herbert V: Detection of malabsorption of vitamin B₁₂ due to gastric or intestinal dysfunction. *Semin Nucl Med* 2:220-234, 1972.
 140. Gobuty AH: Clinical radiopharmacy: troubleshooting the Schilling test. *ASHP Signal* pp 5-6, November 1979.
 141. Halpern SE, Hagan PL, Chauncey D, et al: The effect of certain variables on the tumor and tissue distribution of tracers. Part I: carrier. *Invest Radiol* 14:482-492, 1979.
 142. Hoffer P: Gallium: mechanisms. *J Nucl Med* 21:282-285, 1980.
 143. Goldenberg DM, DeLand F, Kim E, et al: Use of radiolabeled antibodies to carcinoembryonic antigen for the detection and localization of diverse cancers by external photoscanning. *N Engl J Med* 298:1384-1388, 1978.
 144. Goldenberg DM: Tumor imaging with monoclonal antibodies. *J Nucl Med* 24:360-362, 1983.
 145. Katzenellenbogen JA, Carlson KE, Heiman DF, et al: Receptor-binding radiopharmaceuticals for imaging breast tumors: estrogen-receptor interactions and selectivity of tissue uptake of halogenated estrogen analogs. *J Nucl Med* 21:550-558, 1980.
 146. Feenstra A, Vaalburg W, Nolten GMJ, et al: Estrogen receptor binding radiopharmaceuticals: II. Tissue distribution of 17 α -methyl estradiol in normal and tumor-bearing rats. *J Nucl Med* 24:522-528, 1983.
 147. Larson SM, Brown JP, Wright PW, et al: Imaging of melanoma with I-131 labeled monoclonal antibodies. *J Nucl Med* 24:123-129, 1983.
 148. Korn N, Nordblom GD, Counsell RE: The effect of vehicle on the tissue distribution profiles of radioiodinated cholesterol esters in the rat. *Int J Nucl Med Biol* 8:27-32, 1981.
 149. Swarbrick J: Solubilized systems in pharmacy. *J Pharm Sci* 54:1229-1237, 1965.
 150. Burnell RH, Maxwell GM: General and coronary haemodynamic effects of Tween 20. *Aust J Exp Biol Med Sci* 52:151, 1974.
 151. Feinendegen LE: Cardiac imaging with labeled fatty acids for the diagnosis of coronary heart disease. Presented at the International Congress of Cardiac Ischemia and Arrhythmias—Diagnostic Methods and Associated Therapy, Montreux, Switzerland, April 1-4, 1979.
 152. BASF Wyandotte Corp: *Pluronic Polyols—Toxicity and Irritation Data*, product information catalog. Wyandotte, MI, BASF Wyandotte Corp, Industrial Chemicals Group.
 153. Study KT, Schultz HW, Laven DL: The effect of bacteriostatic saline on ^{99m}Tc-labeled radiopharmaceuticals. *J Nucl Med Technol* 9:115-116, 1981.
 154. Charlton JC: Problems characteristic of radioactive pharmaceuticals. In Andrew GA, et al (eds): *Radioactive Pharmaceuticals*. Oak Ridge, TN, US Atomic Energy Commission, 1966, pp 33-50.
 155. Mayer K, Dwyer A, Laughlin JS: Spleen scanning using ACD-damaged red cells tagged with ⁵¹Cr. *J Nucl Med* 11:455-458, 1971.
 156. Halpern S, Alazraki N, Littenberg R, et al: ¹²³I thyroid uptakes: capsule versus liquid. *J Nucl Med* 14:507-510, 1973.
 157. Cohen Y: Chemical and radiochemical purity of radioactive pharmaceuticals related to their biological behavior. In Andrews GA, et al (eds): *Radioactive Pharmaceuticals*. Oak Ridge, TN, US Atomic Energy Commission, 1966, pp 67-91.
 158. Haney TA, Wedeking P, Morcos N, et al: A therapeutic and diagnostic ¹²³I capsule formulation with minimal volatility and maximum bioavailability. *J Nucl Med* 22:P74, 1981.
 159. Baum DC, Bowen BM, Wood DE: Comparison of the bioavailability of cyanocobalamin from capsule and liquid dosage forms. *Am J Hosp Pharm* 32:1047-1049, 1975.
 160. McDonald JWD, Barr RM, Barton WB: Spurious Schilling test results obtained with intrinsic factor enclosed in capsules. *Ann Intern Med* 83:827-829, 1975.
 161. Jacobson BE, Onstad GR: Misleading second-stage Schilling tests due to inactive intrinsic factor concentrate. *Ann Intern Med* 91:579-580, 1979.
 162. Ponto JA: Questionable bioactivity of intrinsic factor for second-stage Schilling test. *Am J Hosp Pharm* 37:1294-1296, 1980.
 163. Pathy MS, Kirkman S, Molloy MJ: An evaluation of simultaneously administered free and intrinsic factor bound radioactive cyanocobalamin in the diagnosis of pernicious anemia in the elderly. *J Clin Pathol* 32:244-250, 1979.
 164. Choy YC, Kim EE, Domstad PA, et al: Reliability of dual isotope Schilling test for the diagnosis of pernicious anemia or malabsorption syndrome. *J Nucl Med* 21:P26, 1980.
 165. Fairbanks VF, Wahner HW, Valley TB, et al: Spurious results from dual-isotope (Dicopac) vitamin B₁₂ absorption test due to rapid or variable rates of exchange of ⁵⁸Co-B₁₂ for ⁵⁹Co-B₁₂ bound to intrinsic factor. *Nucl Med Commun* 4:17-23, 1983.
 166. Donaldson RM, Katz JH: Exchange between free and gastric juice-bound cyanocobalamin. *J Clin Invest* 42:534-545, 1963.
 167. Browning EJ, Banerjee K, Reisinger WE: Airborne concentration of I-131 in a nuclear medicine laboratory. *J Nucl Med* 19:1078-1081, 1978.
 168. Lockett LW, Stofer RE: Radiiodine volatilization from reformulated sodium iodide ¹³¹I oral solution. *J Nucl Med* 21:477-479, 1980.
 169. Carey JE, Swanson DP: Thyroid contamination from airborne ¹³¹I. *J Nucl Med* 20:362, 1979.
 170. Jackson GL, MacIntyre F: Accumulation of radioiodine in staff members. *J Nucl Med* 20:995, 1979.
 171. Maguire WJ: A precaution for minimizing radiation exposure from iodine vaporization. *J Nucl Med Technol* 8:90-93, 1980.
 172. Nishiyama H, Lukes SJ, Mayfield G, et al: Internal contamination of laboratory personnel by ¹³¹I. *Radiology* 136:767-771, 1980.
 173. Howard BY: Safe handling of radioiodinated solutions. *J Nucl Med Technol* 4:28-30, 1976.
 174. Croft BY: Safe handling of radioiodine. *J Nucl Med* 20:362-363, 1979.
 175. Wolfangel RG: Accumulation of radioiodine in staff members. Reply. *J Nucl Med* 20:995, 1979.
 176. Grossman LW, Williams CC: Chilling—an effective way of reducing volatility of therapeutic iodine solutions. *J Nucl Med* 21:P93, 1980.
 177. Ponto JA: Expiration times for ^{99m}Tc. *J Nucl Med Technol* 9:40-41, 1981.
 178. Baker GA, Lum DJ, Smith EM, et al: Significance of radiocontaminants in ¹²³I for dosimetry and scintillation camera imaging. *J Nucl Med* 17:740-743, 1976.
 179. Suzuki A, Suzuki MN, Weis AM: Analysis of a radioisotope calibrator. *J Nucl Med Technol* 4:193-198, 1976.
 180. Johnson AS, Baker SI, Arnold JE, et al: Radionuclide impurities in commercial ¹²³I and their influence on the dose calibrator assay of ¹²³I. *J Nucl Med* 16:540, 1975.
 181. Hughes JA, Williams CC, Thomas SR, et al: Potential errors caused by variable radionuclidic purity of ¹²³I. *J Nucl Med Technol* 7:167-170, 1979.
 182. Chervu S, Chervu LR, Goodwin PN, et al: Thyroid uptake measurements with ¹²³I: problems and pitfalls: concise communication. *J Nucl Med* 23:667-670, 1982.
 183. Grossman LW, Lukes SJ, Kruger JB, et al: The influence of measurement technique and ¹²⁴I contamination on ¹²³I thyroid uptake determinations. *J Nucl Med* 24:P104, 1983.
 184. Polak JF, English RJ, Holman BL: Performance of collimators used for tomographic imaging of ¹²³I contaminated with ¹²⁴I. *J Nucl Med* 24:1065-1069, 1983.
 185. Madsen MT, Patel J, Thakur ML, et al: Collimator selection and ¹²⁴I contamination determination for ¹²³I imaging studies. *J Nucl Med* 25:P106, 1984.
 186. Kasulis PW, Hill TC, Lee RG, et al: Comparison of gamma camera response to ¹²³I (p,5n) and ¹²³I (p,2n). *J Nucl Med Technol* 12:90-91, 1984.
 187. Groch MW, Lewis GK: Thallium-201: scintillation camera imaging considerations. *J Nucl Med* 17:142-145, 1976.
 188. Hines HH, Lagunassolar MC: The effect of different levels of ²⁰²Tl and ²⁰⁰Tl radiocontamination on ²⁰¹Tl imaging. *J Nucl Med* 21:P51, 1980.
 189. Ricciardone M, Frey GD, Levine E, et al: Imaging effects of the radiocontaminant ²⁰⁰Tl from 4-day precalibrated lots of a commercially produced ²⁰¹Tl. Presented at the Twenty-fourth Annual Meeting of the Southeastern Chapter of the Society of Nuclear Medicine, Orlando, FL, 1983.
 190. Stadalnik RC: Diffuse lung uptake of ^{99m}Tc-sulfur colloid. *Semin Nucl Med* 10:106-107, 1980.
 191. Tofe AJ, Francis MD: Optimization of the ratio of stannous tinethane-1-hydroxy-1,1-diphosphate for bone scanning with ^{99m}Tc-pertechnetate. *J Nucl Med* 15:69-74, 1974.
 192. Ford DR: Evaluation of commercially and electrolytically produced technetium ^{99m}Tc human serum albumin. *Am J Hosp Pharm* 35:1081-1083, 1978.
 193. Zimmer AM, Pavel DG, Karesh SM: Technical parameters of in vivo red blood cell labeling with technetium-99m. *Nuklearmedizin* 18:241-246, 1979.
 194. Eckelman W, Richards P, Atkins HL, et al: Visualization of the human spleen with ^{99m}Tc-labeled red blood cells. *J Nucl Med* 12:310-311, 1971.
 195. Majewski W, Zimmer AM, Spies SM: Radiochemical evaluation of commercial hepatobiliary IDA radiopharmaceuticals. *J Nucl Med Technol* 9:116, 1981.
 196. Cooper PA, Zimmer AM: Radiochemical purity and stability of commercial ^{99m}Tc stannous DTPA kits using a new chromatography technique. *J Nucl Med Technol* 3:208-209, 1975.
 197. Ponto J, Patten S: Liver uptake of ^{99m}Tc DMSA. *View-Box* 2:1-2, 1983.
 198. McAfee JG, Grossman ZD, Gagne G, et al: Comparison of renal extraction efficiencies for radioactive agents in the normal dog. *J Nucl Med* 22:333-338, 1981.
 199. Chilton H, Lewis JC, Molsinger SF, et al: Reticuloendothelial distribution of a colloid-like material in 6 β (¹²⁵I)-iodomethyl-19-norcholesterol (NP-59). *J Nucl Med* 20:803-805, 1979.

19

Instrumentation and Procedural Problems in Nuclear Medicine

Kenneth T. Study and Roger W. Taft

In this chapter, the nuclear instrumentation problems, procedural errors, and resultant scintiphoto artifacts that might be encountered before, during, and after a nuclear medicine scan are discussed. In practice, whenever a scintiphoto is of unacceptable quality or contains an evident artifact, it generally is discarded, corrective actions are taken and, if possible, the study is repeated. Instead of discarding the unacceptable scan, however, a notebook of all of these imaging artifacts could be compiled and made accessible to all personnel in the department. This artifact identification notebook is especially useful in a teaching institution in which technologists or residents are being trained. There is no better learning axiom than that "you learn by your mistakes." It is much easier on a department for rookies to learn from the mistakes of others, as cited in the artifact notebook, than for each individual to repeat all the common mistakes made by those who came before. It also becomes easier to identify or recognize the cause of many artifacts by referencing the manual or notebook.

The following should be placed in the artifact notebook:

1. A copy of the scan containing the artifact
2. A brief description of the procedure performed
3. Identification of the instrumentation used (i.e., camera, collimator, etc.)
4. Corrective action taken to remedy the situation
5. A description of the condition(s) causing the artifact

6. Recommendations to prevent the problem from occurring again

An article by Johnson and Damm stresses the importance of maintaining an artifact manual and gives detailed information for organizing one (1). The artifact notebook or manual can be a valuable resource to those who are new to the field of nuclear medicine, new to the department, or unfamiliar with a particular type of instrumentation in the department.

In this chapter, many of the instrumentation-related artifacts and procedural errors that are most likely to occur in a "standard" nuclear medicine imaging laboratory equipped with planar and emission computed tomography (ECT) imaging instrumentation are discussed. A quality control checklist that, if followed rigorously, should prevent the majority of artifacts from ever occurring is presented. When the checklist and artifact notebook are used in conjunction, they become valuable tools for the prevention, diagnosis, and treatment of imaging illnesses.

The actual techniques and methods for performing nuclear medicine quality control and imaging procedures are beyond the scope of this chapter; many excellent textbooks are available for this type of information (2-4). In this chapter, problems in nuclear medicine imaging and the means of rectifying these problems are the primary focus.

Instrumentation and procedural problems may occur in any one or more of the following time frames:

1. During quality control (QC) procedures
2. Immediately prior to patient imaging (during setup)
3. During patient imaging
4. After imaging

In addition to these temporally related categories, instrumentation problems are classified into (a) those associated with planar imaging and (b) those associated with ECT. Those issues or parameters common to both are discussed in this first section on planar imaging problems; those unique to ECT are discussed in the section on ECT imaging problems.

PLANAR IMAGING PROBLEMS

During QC Procedures

Problems associated with QC procedures are probably the most important to study. When QC tests are properly performed, they provide a measurement of the functional status of our instrumentation. When they are improperly performed, they provide an inaccurate measure-

ment of the functional status of our instrumentation and can, in fact, be a source of artifacts or pseudoabnormalities on subsequent patient scans. Much time, effort, and patient inconvenience can usually be saved by performance of adequate QC tests prior to patient imaging.

Many problems can occur with use of bar phantoms for linearity and resolution measurement and with use of field flood phantoms and sheet sources for energy calibration and field uniformity tests. As is evident on the field uniformity image (Fig. 19.1), valuable information is gathered concerning the functional status of the gamma camera. In Figure 19.1, an obvious area of no activity is seen; this is highly indicative of a "burnt-out" photomultiplier tube.

For assessment of linearity, operators in many nuclear medicine laboratories visually judge the straightness of the pattern produced by a parallel bar phantom. Lee (5) has suggested that determination of the straightness of the bar phantom often depends on the subjective opinion of the individual. In his article, Lee has



Figure 19.1. Burnt-out photomultiplier tube on field flood image.

described a quantitative method of measuring intrinsic linearity with use of a Smith orthogonal hole (SOH) phantom.

Field uniformity quite frequently is assessed with use of a field flood phantom or a sheet source at only one energy. A ^{57}Co sheet source rather than a $^{99\text{m}}\text{Tc}$ field flood phantom often is used, since its main photon energy is near that of $^{99\text{m}}\text{Tc}$. Lewis et al. (6) have suggested that patient studies not performed with $^{99\text{m}}\text{Tc}$ may display different field uniformity and that data systems providing field uniformity correction (from ^{57}Co source) can, on occasion, produce clinically significant artifacts. QC studies on all scintillation cameras in the department should be conducted to assure that field response does not change with photon energy.

Lukes et al. (7) have stated that ^{201}Tl imaging artifacts were not detected on $^{99\text{m}}\text{Tc}$ or ^{57}Co field uniformity images. On ^{201}Tl scans of a patient, hot spots were noted; on $^{99\text{m}}\text{Tc}$ and ^{57}Co field flood images, these hot spots were not seen. When a ^{201}Tl field flood image and a ^{133}Xe field flood image were obtained, each displayed the same hot spots as were noted on the ^{201}Tl scan of a patient. This phenomenon occurred, according to the authors, because the crystal in the camera was in the early stages of hydration. Early stages of hydration produce a variety of reflective changes at the front surface of the crystal, where 90% of ^{201}Tl and ^{133}Xe photon absorption occurs (only 38% of $^{99\text{m}}\text{Tc}$ is absorbed in the first 2 mm of the NaI crystal). This crystal hydration was responsible for the energy-dependent nonuniformity.

Many problems can be caused by the simple filling and handling of a field flood phantom. Adding $^{99\text{m}}\text{Tc}$ -labeled particulates or colloids to a field flood phantom should be avoided, as they sometimes do not mix homogeneously throughout the phantom (8). Imaging such a phantom would give the appearance of non-uniform camera response. [$^{99\text{m}}\text{Tc}$]pertechnetate, due to its ionic nature, is the best radiopharmaceutical to add to a phantom. Another common problem is leaving a large air bubble in the phantom which shows up on the image as a paucity of photons in the area of the bubble. This problem is easily circumvented by displacing the air with tap water. A few milliliters of a

bacteriostat such as bleach, periodically placed in the phantom, will prevent bacterial sludge from building up in the phantom and will lessen the messy task of emptying and filling the phantom. Improper positioning of the phantom, its sources, or other sources into the camera field of view during bar phantom imaging can also produce unusual artifacts (9).

Recording media, be it floppy disk or film, must be acceptance tested periodically to insure proper type and function. In a study conducted by Grossman et al. (10), substantial changes in film response as a function of imaging time or dot focus were noted. The phenomenon responsible for this variation in film response was referred to as a "film reciprocity law failure" and is an inherent feature of the image-forming process. Routine QC measures can be structured not only to verify instrument operation but also to standardize photographic response (i.e., an f-stop adjustment to account for various film speeds).

The acceptance test for incoming shipments of film might be a visual inspection of film type and expiration date. Floppies would be acceptance tested to insure they would be the correct type for your computer's disk drives (dual, single density, single- or double-sided). This inspection should be performed immediately prior to initializing each disk or on receipt of a large shipment of disks.

The film cassette is another item that should be periodically inspected for light leaks. After continued use and abuse, cassette slides and frames can become loosened, which allows light leaks to occur.

Figure 19.2 shows what might occur if film from a previous study is left in the camera; a double exposure results. This can be prevented by developing film immediately after completion of a patient's scan. This practice will help to prevent patient-scan mix-ups.

Another oversight that can result in a double-exposure is observing the energy spectrum while the film slide is pulled and then performing a scan without advancing the film (Fig. 19.3).

Many items on the preimaging checklist (Appendix 19.1, page 302) may be inspected during QC testing of the instrumentation. Items such as

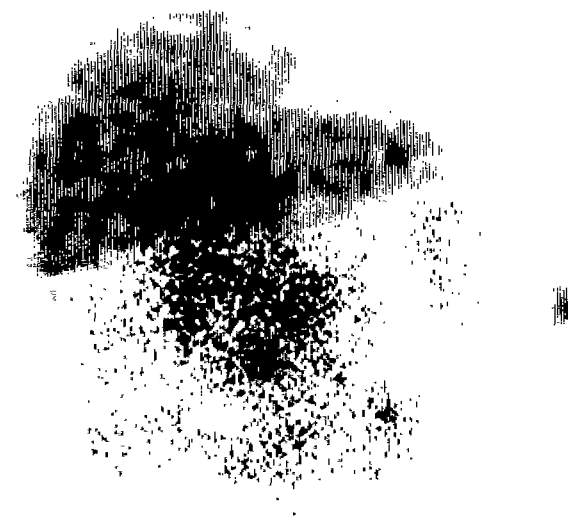

Figure 19.2. Double exposure of thyroid scan on liver scan.

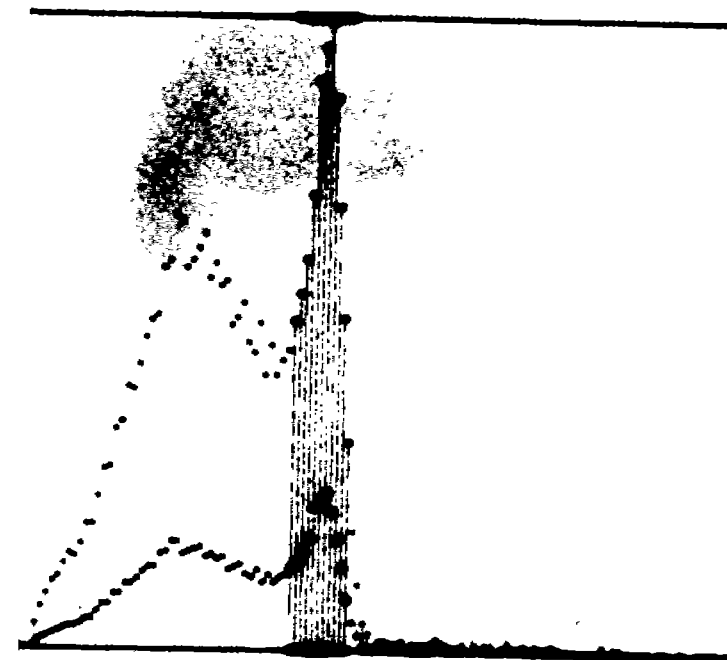

Figure 19.3. Double exposure of energy spectrum on liver scan.

film intensity settings, CRT focus, CRT lens cleanliness, and radiocontamination in the camera field of view can be checked before or during QC testing. Another useful and often-overlooked QC test is that of the scanning mechanism. The scanning mechanism should always have a totally unobstructed path in order to insure free and precise tracking. Therefore, a brief visual inspection of the pathway prior to scanning should always be performed. A strategically misplaced paper clip can bring the entire scan to a halt. Additionally, a scanner linearity test should be periodically performed. A scanner linearity image will insure that successive passes for a dual- or a triple-pass scan are properly and precisely aligned on the resultant scintiphoto. Scan linearity may be readily accomplished by placement of a field flood phantom (or sheet source) on the scanning table so that it overlaps the adjacent scanning paths. The bar phantom is then placed above or below the field flood (depending on where the camera head is) so that a bar phantom transmission scan may be obtained. The bar phantom is then scanned on dual or triple passes (system dependent), and an image is obtained. The resultant image of the bar phantom should display straight bars all the way across the width of the scan. If a parallel-line equal-spacing (PLES) phantom is used, it must be placed on the table in an orientation such that the lead bars are askew from the scanning direction. This orientation will make non-linear alignment on the scintiphoto more apparent to the observer.

Immediately Prior to Imaging

After all necessary QC tests and inspections are performed, setup for a specific study should begin. Several things usually should be accomplished immediately prior to patient arrival.

The proper collimator must be selected for the upcoming examinations. Collimator selection criteria include: energy, resolution, sensitivity, convergent, divergent, pinhole, and tomographic. Improper collimator selection at this point may result in an unacceptable scan, which is why it is included in the QC checklist. Figures 19.4 and 19.5 are sodium [¹³¹I]iodide whole-body scans. The star pattern in these scans is due to septal penetration. A 300-keV

collimator was used for the scan which obviously is not thick enough to adequately collimate the 364-keV ¹³¹I photons. The mechanical act of mounting and removing collimators can, of itself, lead to instrument artifacts. Inadvertently crushing the collimator bolts or other articles in between the collimator and crystal may

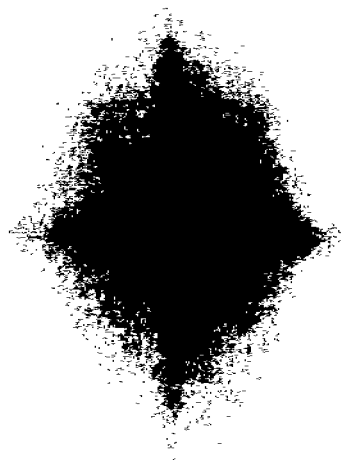

Figure 19.4. Septal penetration. ¹³¹I whole-body scan obtained with use of a 300-keV collimator.

severely damage the crystal or actually bend or close the lead septa of the collimator. Extreme caution must be exercised when collimators are changed, to protect not only the camera but also the technologist and patient. Improperly tightened collimator bolts might be disastrous if a patient is on the receiving end of a falling collimator.

One of the most commonly overlooked settings on the gamma camera console is the radionuclide selection switch or energy potentiometer. Many new cameras feature automatic energy calibration, while most of the older ones require manual calibration by visualization of the energy spectrum. The necessity for "peaking" the camera with a source other than the patient has been substantiated in many studies. Calibration of the camera over the patient (especially an

obese patient) optimizes PHA acceptance of scattered photons and not primary imaging photons, which results in image degradation. The energy spectrum switch should be placed back into the imaging mode if this has not already been done automatically.

The camera or patient orientation switches should be considered next. In some systems, this orientation switch is located on the console, while in others, orientation switches are located on the back of the detector. Proper orientation, if questionable, may be checked by placement of a radioactive source in one quadrant of the camera field of view and then by observation of its relative position on the CRT; orientation settings then may be changed to get the "heads up" orientation to which all of us are accustomed. Nothing can be more aggravating for



Figure 19.5. Septal penetration. ¹³¹I scan obtained with use of a 300-keV collimator.

a diagnostician than to have to flip-flop and rotate one piece of film with multiple views several times in order to get the proper perspective. On most computer systems, proper orientation needs to be selected also.

Some sort of patient identification should be entered into the computer so that the film will be identified accordingly. The computer and camera should then be placed into the proper acquisition mode. The acquisition mode should signal the computer as to what type of study is to be performed and whether there is enough storage left for that study; the computer should indicate when there is not enough storage left. Some systems or procedures require that the operator determine whether there is adequate storage space for an examination. Information given to the computer and/or camera may include preset count or preset time, dynamic or static image, time per frame, time delay between frames, number of images total and per film, gated or nongated study, and information density.

Other items on the preimaging checklist (Appendix 19.1) are of a procedural nature, not an instrumental nature. First and foremost on the procedural portion of the list is: "Did the patient receive the correct radiopharmaceutical for the examination, and did the patient receive the proper amount of the radioactivity for his size and age?" Misadministrations of a diagnostic radiopharmaceutical, although not generally of a life-threatening nature due to their lack of pharmacological activity, do, in fact, result in patient inconvenience, unnecessary radiation dose, waste of time, and unwarranted expense. Too much or too little radiation flux from the patient may result in an image of unacceptable quality. Alterations in the biodistribution of radiopharmaceuticals may be anticipated from the patient's medical history. These alterations may be due to iatrogenic or pathologic causes and necessitate a change in the normal injection or imaging procedure for that particular patient (see the appropriate chapters in this book for details). The patient's chart should be checked to insure that the patient was adequately "prepped" for the nuclear medicine procedure. The chart should also be examined, or the patient questioned, to ascertain whether that patient may

have received any radiodiagnostic, radiotherapeutic, or pharmaceutical agent that might interfere with the upcoming nuclear medicine examination.

After the proper route of administration of the radiopharmaceutical is determined, recheck the patient's identity and the label on the radiopharmaceutical in order to insure that the right patient is receiving the right radiopharmaceutical. Injection technique is of paramount importance in many studies. A single discrete bolus injection is required in many dynamic radionuclide examinations. Problems arising from fragmented bolus injections during quantitative radionuclide angiocardiology are discussed in an article by Brendel et al. (11). If there is a suggested time delay from injection to scanning, double-check to insure that this amount of time has, indeed, elapsed before using the scan.

Procedural errors frequently occur from mis-scheduling two nuclear medicine examinations either sequentially out of order or temporally too close together. Artifacts may occur on a subsequent scan if there is enough residual activity left from a previously introduced radiodiagnostic or radiotherapeutic agent (12).

Harris et al. (13) have described artifacts in ^{131}I renal images. Renal image artifacts due to residual $^{99\text{m}}\text{Tc}$ activity from a previous injection of $^{99\text{m}}\text{Tc}$ -gluceptate were visualized during a [^{131}I]iodohippurate study (at a photopeak energy setting of 364 keV). The cause of these artifacts was explained by the authors as coincidence summing at 281 keV due to a high $^{99\text{m}}\text{Tc}$ counting rate. This problem has been alleviated in newer cameras with pileup rejection circuits.

The controversy continues over what should come first: the ventilation study or the perfusion study. Traditionalists perform the ventilation study with ^{133}Xe first, while other investigators perform the $^{99\text{m}}\text{Tc}$ perfusion study first. Traditionalists argue that if the $^{99\text{m}}\text{Tc}$ perfusion study is performed first, there will be $^{99\text{m}}\text{Tc}$ scattered photons in the ^{133}Xe window on the subsequent ^{133}Xe ventilation study. They argue that there might even be enough scattered $^{99\text{m}}\text{Tc}$ photons accepted that could fill in areas of decreased ventilation on the ^{133}Xe scan. The percent contribution of scattered $^{99\text{m}}\text{Tc}$ photons into the ^{133}Xe window may be easily determined experi-

mentally. Place 2–5 mCi of $^{99\text{m}}\text{Tc}$ -pertechnetate into a field flood phantom and then image this phantom by using the ^{133}Xe window. All imaging parameters including film intensity settings and time should be identical to the ^{133}Xe ventilation imaging procedure. Fluid-filled scattering media may be interposed around the field flood to simulate more closely the human torso.

The percent contribution can be easily calculated by dividing the average number of $^{99\text{m}}\text{Tc}$ counts obtained in this experimental image (at ^{133}Xe settings) by the average number of counts obtained from several ^{133}Xe ventilation images of the patient. Inferences can then be made as to whether this percent contribution of $^{99\text{m}}\text{Tc}$ into the ^{133}Xe window is statistically significant or not. Sometimes, simple visual observation of the experimental image will indicate the outcome. Window size is a parameter that may be varied to minimize the percent contribution.

Fernandez-Ulloa et al. (14) have reported on spectral overlap. They found two cases in which the ^{111}In -labeled leukocyte images were determined to contain artifacts due to $^{99\text{m}}\text{Tc}$ cross talk within the 173-keV photopeak of ^{111}In . In these patients, $^{99\text{m}}\text{Tc}$ -hydroxymethylene diphosphonate (HDP) had been administered within 24 hours prior to the administered ^{111}In -labeled leukocytes. The artifact disappeared when the ^{111}In window was decreased from 20% to 10%. A 24-hour waiting period after a $^{99\text{m}}\text{Tc}$ nuclear medicine examination does not always insure background levels of radioactivity. Depending on biological excretion rate for that patient and the duration of the following images, there could be enough activity to show up as artifacts.

Too long a delay from injection to scanning can be just as detrimental as too short a delay. Several sources of technical error in ^{201}Tl perfusion stress tests, including too long a delay in obtaining the initial poststress images, are described in a book by Mettler and Guibertau (15).

Proper positioning of the patient against the gamma camera is a very important criterion to consider in preparation of a patient to be imaged. Malpositioning and rotation of the patient is the most common cause for diffuse asymmetries of $^{99\text{m}}\text{Tc}$ -phosphonate uptake in bone and

often results in an appearance of asymmetric uptake in the shoulder joints, knee joints, and feet, where this asymmetry is most often noted (16). Physiological curvatures of the skeleton, either normal or pathologic, may be responsible for what appears to be nonsymmetrical uptake of the tracer. The most common observance of this is on a posterior bone scan when the normal curvature of the spine is away from the gamma camera; therefore, the uptake of the bone scanning agent appears to be less in this area than in the rest of the spine that is equidistant from the camera along its course. Improper positioning of the patient can result in various other imaging anomalies, such as pooling effects in the lungs or false positive renal images (17).

If a mental or even a documented preimaging check is made of all of the aforementioned instrument and patient parameters, an acceptable scan most likely will result. Once a nuclear medicine scan is underway, however, in-process problems may occur, regardless of the thoroughness of the preimaging preparation.

During Imaging

In Table 19.1 are listed several factors that need to be evaluated during imaging of the patient. The patient is the primary contributor to in-process scanning problems. Patients can move during the scan, they can get sick, they can lose bladder or bowel control, or they can become anxious during the scan and actually panic. Rule 1 is to be attentive to your patient before, during, and after the examination.

Table 19.1.

Planar In-process Imaging Checklist

_____	Has patient movement been minimized throughout scan?
_____	Are there attenuating objects over the patient?
_____	Were any noticeable patient excreta found on the collimator, table, or sheets?
_____	Have all radioactive sources and radiocontaminants been removed from the camera field of view?
_____	Is the scanning device tracking and indexing properly?
_____	Are the camera and table tracks clear?
_____	Is the patient receiving reassurances and progress reports on the scan?

Many patient-associated imaging artifacts may be eliminated by keeping the patient informed as to what to expect from the examination and the status of the scan as it is in progress. In a book by Wells and Bernier (18), many actual patient-associated imaging artifacts (movement, contamination, attenuating objects) are described. Several authors have reported photon-deficient areas occurring on bone and renal images which resulted from the patient having too heavy a lunch (19, 20). Other items listed in Table 19.1 include assuring that the scanning device has a clear unobstructed path in which to operate and that it is tracking and indexing properly, as well as determining whether or not the film slide has been pulled.

After Imaging

If the examination has gone well up to this point, there are only a few more items left that can go wrong. The postimaging checklist (Table 19.2) contains items dealing mainly with verifying that the film is processed properly (and is of acceptable quality) and that the computer has acquired all the necessary data. One item not on the postimaging checklist is the patient. Although the patient's behavior at this time cannot affect the quality of the finished scan, it is important to make sure that the patient is relaxed. Many technologists (including myself), after completion of the examination, have walked away to process the film and have left the patient in the scan position. This negligent practice can affect the quality of any unanticipated or repeat scans that may be deemed necessary after the standard views are taken. A patient who has spent an unnecessary amount of time in an unrelaxed position is more irritable, is more uncooperative, will move more, and may refuse to undergo any more imaging. It is important to be as empathetic with the patient as possible.

Table 19.2.

Planar Postimaging Checklist

- _____ Has the film slide been returned prior to cassette removal?
- _____ Has the film been properly processed?
- _____ Have image suitability and quality been checked prior to patient dismissal?

At this time, the result of all the preparations, checks, and double-checks should manifest themselves as a completely adequate, diagnostically accurate, quality nuclear medicine examination that is carried out correctly the first time.

ECT IMAGING PROBLEMS

Single photon emission computed tomography (SPECT) imaging (Fig. 19.6) is subject to all of the problems of planar imaging plus a unique set of its own. To obtain clinically useful images requires strict attention to quality control procedures (Table 19.3) and a knowledge of SPECT imaging artifacts and their causes. Three sources of artifacts in tomographic images have been identified by Harkness et al. (21): (a) errors in camera setup and calibration, (b) errors in patient preparation and the setup of the camera in relation to the patient, and (c) improper choice of reconstruction filter parameters. Of these three, errors in camera setup and calibration are the most significant source of image artifacts.

Problems Associated with Calibration of SPECT Cameras Prior to Imaging

SPECT cameras must routinely be calibrated for center of rotation (COR), pixel or voxel size,

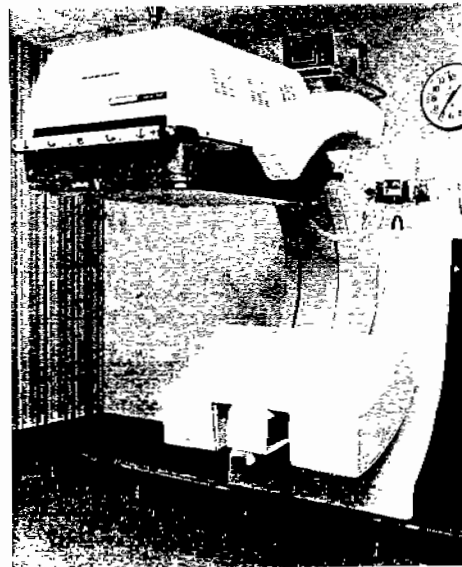

Figure 19.6. ECT camera.

Table 19.3.
Additional Checklist for ECT-only Imaging

- _____ Is the camera in the ECT mode?
- _____ Is the computer set for ECT acquisition?
- _____ Has the patient been positioned at the center of rotation?
- _____ Does the camera clear the patient throughout manual rotation?
- _____ Does the organ of interest remain in the field of view throughout manual rotation?
- _____ Is the up-to-date flood correction image stored in the computer for the collimator, and is the magnification mode in use?
- _____ Are proper projection filters being used for the examination?
- _____ Is the attenuation coefficient correct?
- _____ What are the angular range and number of angles?
- _____ What is the starting angle?
- _____ What is the direction of rotation?
- _____ Is the time per image correct?

and field uniformity. Of these, field uniformity has the most effect on tomographic image quality. Field flood nonuniformities of more than $\pm 1\%$ will result in bull's-eye artifacts in reconstructed tomographic images. COR errors result in loss of resolution or the introduction of artificial structures. A point source imaged over 180° with a COR error will result in a tuning fork- or doughnut-shaped reconstruction. Even



Figure 19.7. Jaszczak QC phantom.

small COR errors can result in hot or cold spots on a ^{201}Tl image. Pixel size is subject to drift, and SPECT cameras should be calibrated for pixel size along with the COR. Pixel or voxel (volume element) size must be known for accurate size and volume determinations. A calibration set consisting of pixel size, COR, and field uniformity should be stored for each set of acquisition conditions. Field uniformity, COR, and pixel size vary with the collimator and magnification modes. Field uniformity can also vary with camera orientation; thus it is important to acquire the field floods used for correction in the same orientation as will be used for patient acquisition. Routine imaging of an ECT phantom, such as the Jaszczak phantom shown in Figure 19.7, is the best way to detect changes in camera performance.

Problems Associated with Patient Preparation and the Setup of the Camera in Relation to the Patient

Tomographic reconstructions magnify problems due to preparation of the patient. Since SPECT images are reconstructed from many images acquired around the patient, care must be taken in patient positioning. The patient should be parallel with the axis of rotation of the camera, and the detector head should be as close as possible to the patient for better resolution. Prior to every acquisition, care should be taken to (a) level the detector head and (b) assure that the detector can rotate around the patient without hitting the patient. It is also necessary to check that the organ of interest remains in the field of view throughout the rotation. Patients arms should be above their head when organs of the thorax or abdomen are imaged. If the arms are left at the patient's side, they create uneven attenuation and will result in a patchy appearance on images of organs such as the liver. In transaxial images, a starburst artifact will result if a hot source (such as injection site with extravasation) is in the field of view for some of the projection images. Other factors degrading the reconstructed images are patient motion and the presence of attenuation sources inside or outside of the patient. Recent barium studies can cause artifacts to appear on reconstructed images of the liver.

Problems Associated with Improper Reconstruction Parameters

Image artifacts can also be introduced through improper reconstruction parameters. These artifacts are the easiest to correct, however, as they do not require reimaging of the patient. Reconstruction artifacts include: image blurring, image noise, and an intense ring around the outer edge of an organ due to improper attenuation correction. The choice of the proper reconstruction filter is related to the clinical imaging situation and is dependent on the information density of the images. A filter that is too smooth can blur or remove normal structures as well as lesions. At the other end of the spectrum, a filter that is too sharp can intensify image noise and cause the appearance of structured noise in the organ of interest and background (Fig. 19.8). The proper filter can be selected by (a) imaging of phantoms simulating actual clinical situations or (b) acquisition of known normal patient data and reconstruction with use of various filters in order to select the one yielding the best representation (Fig. 19.9).

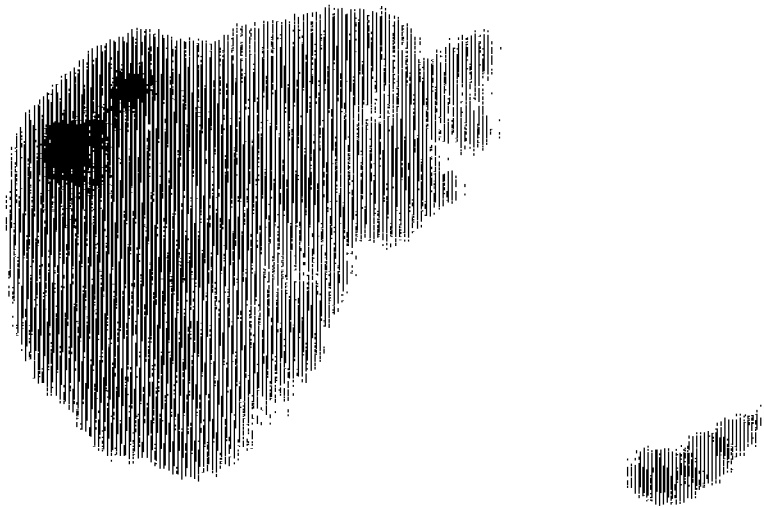

Figure 19.8. Normal liver scan reconstructed with too sharp of a filter.

CONCLUSION

The vast majority of instrumentation and procedural problems in nuclear medicine can be prevented. Usually, these result from human error, poor judgment, or human uncooperativeness which produces imaging artifacts. Rare is the spontaneous malfunction of imaging equipment. Most problems can be traced back to a breach of procedure. Nuclear medicine imaging is becoming less of an art and more of a science. Instrumentation is becoming more sophisticated, reliable, and "foolproof." Following the basic principles outlined in this chapter, such as setting up a nuclear medicine imaging "bloopers" notebook and using either a mental or a documented imaging checklist, will reduce to a bare minimum camera downtime, repeat scans, radiation exposure to self and patient, frustration, stress, and poor-quality images.

REFERENCES

1. Johnson CK, Damm DW: Programmed learning manual for artifact identification. *J Nucl Med Technol* 4:31-33, 1976.

2. Early PJ, Sodee DB: *Principles and Practice of Nuclear Medicine*. St Louis, CV Mosby, 1985.
3. Rollo FD: *Nuclear Medicine Physics, Instrumentation, and Agents*. St Louis, CV Mosby, 1977.
4. Bernier DR, Langan JK, Wells LD: *Nuclear Medicine Technology and Techniques*. St Louis, CV Mosby, 1981.
5. Lee KH: Quantitative assessment of linearity of scintillation cameras. *Radiology* 136:790-792, 1980.
6. Lewis JT, Neff RA, Nishiyama H, Bahr GH: The effect of photon energy on tests of field uniformity in scintillation cameras: concise communication. *J Nucl Med* 19:553-556, 1978.
7. Lukes SJ, Grossman LW, Nishiyama H: Thallium-201 imaging artifacts not detected by technetium-99m or cobalt-57 quality control testing. *Radiology* 146:237-239, 1983.
8. Appledorn CR, Hallberg JR, Knight RL: Unusual flood field image. *J Nucl Med Technol* 5:214, 1977.
9. Leklitner ML, Benedetto AR: Case report: the phantom of the bar phantom. *J Nucl Med Technol* 11:169-170, 1983.
10. Grossman LW, Van Tuinen RJ, Kruger JB, Scholz KL: Film reciprocity law failure in scintillation camera imaging. *Radiology* 138:697-700, 1981.
11. Brendel AJ, Comnenges D, Salamon R, et al: Deconvolution analysis of radionuclide angiocardiography curves: problems arising from fragmented bolus injections. *Eur J Nucl Med* 8:93-98, 1983.
12. LaRocque LR: Case of the quarter. *J Nucl Med Technol* 5:163-165, 1977.
13. Harris CC, Wilkinson RH, Schuler FR: Artifacts in iodine-131 renal images due to coincidence summing of technetium-99m photons. *Radiology* 146:505-507, 1983.
14. Fernandez-Ulloa M, Hughes JA, Krugh KB, Chin D: Bone imaging in infections: artifacts from spectral overlap between a Tc-99m tracer and In-111 leukocytes. *J Nucl Med* 24:589-592, 1983.
15. Mettler FA, Guiberteau MJ: *Essentials of Nuclear Medicine Imaging*. New York, Grune & Stratton, 1983, p 117.
16. Maisey MN, Britton KE, Gilday DL: *Clinical Nuclear Medicine*. Philadelphia, Saunders, 1983, pp 139-141.
17. Rao GM, Nagesh KG, Guruprakash GH: Position-related false-positive renal imaging. *Clin Nucl Med* 5:318, 1980.
18. Wells LD, Bernier DR: *Radionuclide Imaging Artifacts*. Chicago, Year Book Medical Publishers, 1980.
19. Croft BY, Teates CD: "Lunch syndrome", a bone-scanning artifact: case report. *Clin Nucl Med* 3:137-138, 1978.
20. Crucitti TW, Valdez VA: Photon-deficient area with Tc-99m DTPA. *J Nucl Med Technol* 6:211-213, 1978.
21. Harkness BA, Rogers WL, Clinthorne NH, Keyes JW: SPECT: quality control procedures and artifact identification. *J Nucl Med Technol* 11:55-60, 1983.

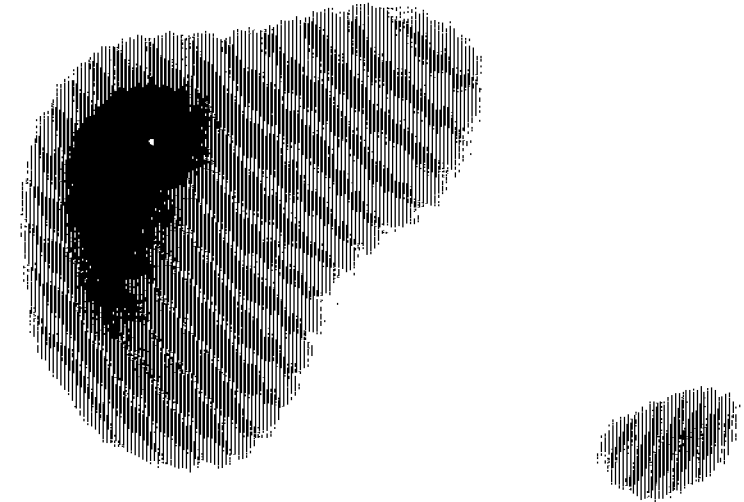

Figure 19.9. Normal liver scan.

-
- _____ Is the camera peaked for the proper radionuclide?
 - _____ Has the proper collimator (energy, resolution) been selected for the study?
 - _____ Is the film intensity set correctly?
 - _____ Is the cathode ray tube (CRT) in focus?
 - _____ Is the CRT lens clean?
 - _____ Has the appropriate time per image been selected?
 - _____ Is the orientation of the camera and computer appropriate?
 - _____ Has the proper camera and computer acquisition mode been selected for the study?
 - _____ Is there enough computer storage for the examination?
 - _____ Are the floppy disks initialized?
 - _____ Are floppy disks the correct type?
 - _____ Has patient identification been entered into the computer?
 - _____ Are magnification settings on the camera and computer correct?
 - _____ Is the film type correct, and is the film loaded properly?
 - _____ Is the CRT selection switch set for imaging?
 - _____ Has the correct radiopharmaceutical and proper dose been selected for the patient?
 - _____ Has the proper injection site been selected?
 - _____ Is the patient adequately prepped?
 - _____ Is the time delay from injection to scanning adequate?
 - _____ Has the patient received any pharmaceutical, radiodiagnostic, or radiotherapeutic agents which might interfere with the exam?
 - _____ Is the patient properly positioned?
-

Appendix 19.1. ECT and planar preimaging quality control checklist.

20

Adverse Reactions Associated with Radiopharmaceuticals

M. Annette Cordova, William B. Hladik III, Buck A. Rhodes, and Harold L. Atkins

Because the term "adverse reaction" is most commonly associated with compounds known as "drugs," it is important to understand why radiopharmaceuticals are considered to be drugs and which radioactive substances are classified as radiopharmaceuticals.

According to the United States Food, Drug, and Cosmetic (FD & C) Act (1), drugs are defined as "articles intended for use in the diagnosis, cure, mitigation, treatment, or prevention of disease in man or other animals; . . . but does not include devices or their components, parts, or accessories." In general terms, a radiopharmaceutical is a compound labeled with either an intrinsic or a "foreign" radionuclide for use in the diagnosis or therapy of disease and, as such, qualifies as a drug.

Nearly all radioactive substances that are administered parenterally, orally, or topically for diagnosis or therapy are considered to be radiopharmaceuticals. This includes reagent kits used in the preparation of radioactive drugs as well as generator systems which produce radionuclides for clinical use. Notable exceptions include sealed sources of radionuclides used as therapeutic implants and radiotracers that are components of in vitro diagnostic kits. These last two items are classified as devices rather than drugs.

In 1975, the United States Food and Drug Administration (FDA) "officially recognized" radiopharmaceuticals as drugs by terminating a then-existing exemption for radioactive pharmaceuticals from the investigational new drug requirement of the FD & C Act. Thus, radiophar-

maceuticals are subject to the same regulatory requirements that are in effect for all new drugs, including the reporting of adverse reactions which are attributable to these agents. Even after the approval and introduction of these agents into the marketplace, it is important to have an established process for monitoring their safe use.

DEFINITION OF ADVERSE REACTION

In the United States Code of Federal Regulations (2), an adverse reaction is defined as "any adverse experience associated with the use of the drug, whether or not considered drug related, and includes any side effect, injury, toxicity, or sensitivity reaction, or significant failure of expected pharmacologic action." This definition does not entirely apply to radiopharmaceuticals because they are not generally expected to elicit a pharmacologic response (3). Furthermore, although some of the ingredients incorporated into certain radiopharmaceuticals may be considered to be chemically or pharmacologically toxic, for diagnostic purposes they are given in minute quantities well below the toxic range (3-5). The chemical toxicity of clinically used radiotracers should present no problems as long as acceptable limits of specific activity are not exceeded (4).

Radiopharmaceuticals, unlike other drugs, emit radiation. Any acute adverse effects attributed to the radiation itself, especially with regard to diagnostic radiopharmaceuticals, are most likely due to an overdose and are more properly classified as misadministration. I-

-
- _____ Is the camera peaked for the proper radionuclide?
 - _____ Has the proper collimator (energy, resolution) been selected for the study?
 - _____ Is the film intensity set correctly?
 - _____ Is the cathode ray tube (CRT) in focus?
 - _____ Is the CRT lens clean?
 - _____ Has the appropriate time per image been selected?
 - _____ Is the orientation of the camera and computer appropriate?
 - _____ Has the proper camera and computer acquisition mode been selected for the study?
 - _____ Is there enough computer storage for the examination?
 - _____ Are the floppy disks initialized?
 - _____ Are floppy disks the correct type?
 - _____ Has patient identification been entered into the computer?
 - _____ Are magnification settings on the camera and computer correct?
 - _____ Is the film type correct, and is the film loaded properly?
 - _____ Is the CRT selection switch set for imaging?
 - _____ Has the correct radiopharmaceutical and proper dose been selected for the patient?
 - _____ Has the proper injection site been selected?
 - _____ Is the patient adequately prepped?
 - _____ Is the time delay from injection to scanning adequate?
 - _____ Has the patient received any pharmaceutical, radiodiagnostic, or radiotherapeutic agents which might interfere with the exam?
 - _____ Is the patient properly positioned?
-

Appendix 19.1. ECT and planar preimaging quality control checklist.

20

Adverse Reactions Associated with Radiopharmaceuticals

M. Annette Cordova, William B. Hladik III, Buck A. Rhodes, and Harold L. Atkins

Because the term "adverse reaction" is most commonly associated with compounds known as "drugs," it is important to understand why radiopharmaceuticals are considered to be drugs and which radioactive substances are classified as radiopharmaceuticals.

According to the United States Food, Drug, and Cosmetic (FD & C) Act (1), drugs are defined as "articles intended for use in the diagnosis, cure, mitigation, treatment, or prevention of disease in man or other animals; . . . but does not include devices or their components, parts, or accessories." In general terms, a radiopharmaceutical is a compound labeled with either an intrinsic or a "foreign" radionuclide for use in the diagnosis or therapy of disease and, as such, qualifies as a drug.

Nearly all radioactive substances that are administered parenterally, orally, or topically for diagnosis or therapy are considered to be radiopharmaceuticals. This includes reagent kits used in the preparation of radioactive drugs as well as generator systems which produce radionuclides for clinical use. Notable exceptions include sealed sources of radionuclides used as therapeutic implants and radiotracers that are components of in vitro diagnostic kits. These last two items are classified as devices rather than drugs.

In 1975, the United States Food and Drug Administration (FDA) "officially recognized" radiopharmaceuticals as drugs by terminating a then-existing exemption for radioactive pharmaceuticals from the investigational new drug requirement of the FD & C Act. Thus, radiophar-

maceuticals are subject to the same regulatory requirements that are in effect for all new drugs, including the reporting of adverse reactions which are attributable to these agents. Even after the approval and introduction of these agents into the marketplace, it is important to have an established process for monitoring their safe use.

DEFINITION OF ADVERSE REACTION

In the United States Code of Federal Regulations (2), an adverse reaction is defined as "any adverse experience associated with the use of the drug, whether or not considered drug related, and includes any side effect, injury, toxicity, or sensitivity reaction, or significant failure of expected pharmacologic action." This definition does not entirely apply to radiopharmaceuticals because they are not generally expected to elicit a pharmacologic response (3). Furthermore, although some of the ingredients incorporated into certain radiopharmaceuticals may be considered to be chemically or pharmacologically toxic, for diagnostic purposes they are given in minute quantities well below the toxic range (3-5). The chemical toxicity of clinically used radiotracers should present no problems as long as acceptable limits of specific activity are not exceeded (4).

Radiopharmaceuticals, unlike other drugs, emit radiation. Any acute adverse effects attributed to the radiation itself, especially with regard to diagnostic radiopharmaceuticals, are most likely due to an overdose and are more properly classified as misadministration. I am-

term adverse effects due to the radiation, such as genetic effects or the induction of cancer, are difficult to monitor and document because they generally occur so late and with such low theoretical incidence (3); some have been attributed to the use of therapeutic radiopharmaceuticals, however (6, 7).

Rawlins and Thompson (8) have divided adverse reactions to therapeutic drugs into two types. Type A reactions are due to the pharmacologic action of a drug, are relatively frequent, and are often dose dependent. Type B reactions, which are unexpected and unrelated to the normal pharmacology of the drug, best describe the majority of reactions to radiopharmaceuticals.

Several authors have further defined what is and what is not an adverse reaction to radiopharmaceuticals. The following is a composite definition incorporating major discriminating elements of these definitions:

1. The reaction is an unexpected or unusual and undesirable clinical manifestation resulting from the administration of a radiopharmaceutical (3, 4).
2. The reaction is associated with the vehicle carrying the radiation and not with the radiation itself (4, 9).
3. The reaction does not result from an overdose, which is more properly classified as misadministration (3, 9).
4. The reaction is not a result of injury caused by poor injection technique (10).

It should be noted that not all authors agree with this entire definition. In Europe, particularly in the United Kingdom, acute radiation effects resulting from miscalibration, radionuclidic impurities, or maldistribution (including slow biologic clearance) of the radiotracer are also considered to be adverse reactions (11, 12).

REPORTING SYSTEMS

An effective, large-scale, adverse reaction reporting system for radiopharmaceuticals is important and necessary for several reasons. First, compared with most nonradioactive therapeutic drugs, radiopharmaceuticals are administered infrequently and usually in single doses.

Therefore, to compile a large amount of data at a single hospital or even from a small group of related institutions is extremely difficult. In addition, the reported incidence of adverse reactions is quite low; thus, it is unlikely that any one practitioner would be able to note trends or problems associated with a particular radiopharmaceutical. Unfortunately, many reactions probably go unnoticed, because nuclear medicine personnel see the patient for only a short period and the patient may then be lost to follow-up once he or she has left the nuclear medicine department (10). Moreover, new radiopharmaceuticals often replace older ones in the same organ imaging category within the span of only a few years, which thus limits the collective experience with any one agent (10).

Data concerning adverse reactions to radiopharmaceuticals have been solicited in the United States by the Society of Nuclear Medicine (SNM) since 1967. The established reporting system was modified in 1976 and for many years was a cooperative effort of the SNM, the United States Pharmacopeial Convention (USPC), and the FDA. Adverse reactions and product defects were reported on a SNM Drug Problem Report form (FDA 2822). These reports were mailed to the USPC who sent a copy to the SNM headquarters, the manufacturer, and the FDA for follow-up (13). A second modification of the reporting system occurred in late 1985 when the FDA discontinued the use of form FDA 2822. Instead, it was recommended that nuclear medicine practitioners should report adverse reactions associated with radiopharmaceuticals on form FDA 1639, the Adverse Reaction Report for Drugs and Biologics (Figure 20.1). This form for the voluntary reporting of reactions to radiopharmaceuticals and nonradioactive drugs is used not only by practitioners but also by drug manufacturers, as required by Title 21 of the Code of Federal Regulations (21 CFR 314.80). These reports are reviewed, evaluated, and computerized by the FDA Division of Drug and Biological Product Experience. Information collected by these reporting systems has been used (a) to alert the profession to potential or actual problems before they become widespread and (b) to define the types, characteristics, and incidence of adverse

DEPARTMENT OF HEALTH HUMAN SERVICES PUBLIC HEALTH SERVICE FOOD AND DRUG ADMINISTRATION (HFK-720) ROCKVILLE, MD 20887				Form Approved: OMB No. 0910-0001 Expiration Date: May 31, 1986.			
ADVERSE REACTION REPORT (Drugs and Biologics)				FDA CONTROL NO. _____ ACCESSION NO. _____			
I. REACTION INFORMATION							
1. PATIENT ID/INITIALS (In Confidence)		2. AGE YRS.	3. SEX	4-6. REACTION ONSET MO. DA. YR.			8-12. CHECK ALL APPROPRIATE TO REACTION
7. DESCRIBE REACTION(S) (Underline single most important clinical event or reaction term)							<input type="checkbox"/> DIED DUE TO REACTION <input checked="" type="checkbox"/> TREATED WITH RX DRUG <input type="checkbox"/> RESULTED IN, OR PROLONGED, INPATIENT HOSPITALIZATION <input checked="" type="checkbox"/> RESULTED IN SEVERE OR PERMANENT DISABILITY <input type="checkbox"/> NONE OF THE ABOVE
13. RELEVANT TESTS/LABORATORY DATA							
II. SUSPECT DRUG(S) INFORMATION							
14. SUSPECT DRUG(S) (Give manufacturer and lot no. for vaccines/biologics)							20. DID REACTION ABATE AFTER STOPPING DRUG? <input type="checkbox"/> YES <input type="checkbox"/> NO <input type="checkbox"/> NA
15. DAILY DOSE			16. ROUTE OF ADMINISTRATION			21. DID REACTION REAPPEAR AFTER REINTRODUCTION? <input type="checkbox"/> YES <input type="checkbox"/> NO <input type="checkbox"/> NA	
17. INDICATION(S) FOR USE				18. THERAPY DATES (From/To)			
				19. THERAPY DURATION			
III. CONCOMITANT DRUGS AND HISTORY							
22. CONCOMITANT DRUGS AND DATES OF ADMINISTRATION (Exclude those used to treat reaction)							
23. OTHER RELEVANT HISTORY (e.g. diagnoses, allergies, pregnancy with LMP etc.)							
IV. ONLY FOR REPORTS SUBMITTED BY MANUFACTURER				V. INITIAL REPORTER (In Confidence)			
24. NAME AND ADDRESS OF MANUFACTURER (Include Zip Code)				26. NAME AND ADDRESS OF REPORTER (Include Zip Code)			
24a. IND/NDA, NO. FOR SUSPECT DRUG		24b. MFR CONTROL NO.		26b. TELEPHONE NO. (Include area code)			
24c. DATE RECEIVED BY MANUFACTURER		24d. REPORT SOURCE (Check one) <input type="checkbox"/> FOREIGN <input type="checkbox"/> STUDY <input type="checkbox"/> LITERATURE <input type="checkbox"/> HEALTH PROFESSIONAL <input type="checkbox"/> CONSUMER		26c. HAVE YOU ALSO REPORTED THIS REACTION TO THE MANUFACTURER? <input type="checkbox"/> YES <input type="checkbox"/> NO			
25. 15 DAY REPORT <input type="checkbox"/> YES <input type="checkbox"/> NO		25a. REPORT TYPE <input type="checkbox"/> INITIAL <input type="checkbox"/> FOLLOWUP		26d. ARE YOU A HEALTH PROFESSIONAL? <input type="checkbox"/> YES <input type="checkbox"/> NO			
NOTE: Required of manufacturers by 21 CFR 314.80.							
FORM FDA 1639 (5/85)				PREVIOUS EDITION IS OBSOLETE.			

Figure 20.1. Front of Adverse Reaction Report form used in the United States for reporting adverse reactions associated with radiopharmaceuticals, nonradioactive drugs, and biologics.

INSTRUCTIONS FOR COMPLETING FORM FDA - 1639

GENERAL

- * Use a separate Form FDA - 1639 for each patient.
- * Additional pages may be attached if the space provided on the Form FDA - 1639 is inadequate.
- * Non-manufacturers should send forms to Food and Drug Administration, Division of Drug and Biological Product Experience, HFN-730, 5600 Fishers Lane, Rockville, MD 20857.
- * For questions call: 301 - 443-4580.
- * Patient and initial reporter identification is held in confidence by the FDA and is not subject to release under the Freedom of Information Act.
- * Reports of serious, suspect reactions are encouraged.
- * Submission of a report does not necessarily constitute an admission that the drug caused the adverse reaction.

SPECIFIC INSTRUCTIONS

I. Reaction Information

- Item 2. Age - For children under 5 years of age write in date of birth (DOB) in Item 1. For congenital malformations, give the age and sex of the infant (even though the mother was exposed).
- Item 7. Describe reaction - Give signs and/or symptoms, diagnoses, course, etc. Underline the single most important descriptive phrase.

II. Suspect Drug Information

- Item 14. Suspect Drug - The trade name is preferred. If a generically produced product is involved, the manufacturer should be identified.
- Item 15. Dose - For pediatric patients, also give body weights.
- Item 20 and 21. NA - is defined as nonapplicable (e.g. when only one dose given or outcome was irreversible).

V. Initial Reporter

- Item 26c. Have you also reported this reaction to the manufacturer? - Your answer facilitates identification of duplicates in the central adverse reaction file. FDA encourages direct reporting even if a report has been submitted to the manufacturer.

NOTE TO MANUFACTURERS (Refer to 21 CFR 314.80) Detailed instructions are contained in the "Draft Guideline for Reporting Adverse Drug Reactions" and/or "Draft Guideline for Reporting Adverse Biologics Reactions".

U.S. G.P.O. 1985-461-364/37054

Figure 20.1—continued. Back of Adverse Reaction Report form used in the United States for reporting adverse reactions associated with radiopharmaceuticals, nonradioactive drugs, and biologics.

CONFIDENTIAL

Results will not be made known to any person without the express permission of the person submitting this report but are 'banked' with the European Reporting Scheme, and the general DHSS Adverse Report Scheme.

REPORT OF AN ADVERSE REACTION ATTRIBUTED TO A RADIOPHARMACEUTICAL

1. Patient Initials Hospital No.
 Age Sex
 Date of Test Nature of Test
 Clinical Diagnosis
2. Radiopharmaceutical: Radionuclide Chemical Form
 Brief details of materials, source, method of preparation & storage - refs.if any

 Has a commercial manufacturer, if involved, been informed? YES / NO
3. Nature of Reaction: Any clinical observations and treatment, if required

 Has the patient received this or a related radiopharmaceutical before?

4. Approximate number of times this preparation has been used uneventfully.

 Other drugs etc. currently being given:
5. Any other comments
 continue overleaf.

Signed Name
 Address

Return to: The Medical Assessor, Radiopharmaceutical Adverse Reaction Reports,
 British Institute of Radiology, 36 Portland Place, London W1N 3DG marked CONFIDENTIAL

Figure 20.2. Form used in the United Kingdom for reporting adverse reactions attributed to radiopharmaceuticals.

JOINT COMMITTEE ON RADIOPHARMACEUTICALS

EUROPEAN NUCLEAR MEDICINE SOCIETY

SOCIETY OF NUCLEAR MEDICINE – EUROPE

ADVERSE REACTION **SEND TO:** National delegate
 DRUG DEFECT or direct to: European Joint Committee on Radiopharmaceuticals
 REPORTING SYSTEM addr.: THE ISOTOPE-PHARMACY
 378 Frederikssundsvej, DK-2700 Brønshøj,
 Denmark.

Radiopharmaceutical (name-code) Manufacturer Lot.no.

If relevant: Radionuclide generator (code) Manufacturer Lot.no.

Key Index – Please mark.

ADVERSE REACTION:
 Type

- Allergic
- Pyrogenic
- Drug effect
- Other:

Reaction:

- Moderate
- Severe
- Fatal

Probability of connection to

R.Ph. Administration:

- Low
- Medium
- High

RADIOPHARMACEUTICAL DEFECT:

- Transport damage
- Label
- Package insert
- Appearance
- Rad.surface contamination
- Radioactive concentration
- Total radioactivity
- Radiochemical purity
- Radionuclidic purity
- pH
- Elution efficiency
- Particulate contamination
- Biodistribution
- Sterility
- Pyrogens
- Other

Date of Incident:

Detailed description: (see also questions in the text)

Please continue if needed

Report sent by:

Name:
 Occupation:
 Institution:
 Address:

Telephone:

Date:

Signature:

Reserved for office use:

Manu- fact.	Product	Lot no.	Defect/ reaction
Country	Department	Dates	

THE JOINT COMMITTEE on RADIOPHARMACEUTICALS OF
 the EUROPEAN NUCLEAR MEDICINE SOCIETY and the
 SOCIETY OF NUCLEAR MEDICINE – EUROPE

Reporting of adverse reactions and drug defects.

The monitoring of defects in radiopharmaceuticals and of adverse reactions associated with the use of radiopharmaceuticals is considered to be an important mean of maintaining and improving the quality and safety of nuclear medicine.

The Joint Committee on Radiopharmaceuticals of the European Nuclear Medicine Society and the Society of Nuclear Medicine – Europe (Gesellschaft für Nuklear Medizin – Europa) have therefore decided to set up a system whereby such information can be collected on an European basis and made available to all parties concerned.

The number of defects and adverse reactions is most probably small. Collection of data from a large area is therefore important in order, that problems can be identified as early as possible. The Committee therefore urges everyone involved in work with radiopharmaceuticals to participate by reporting as soon as possible any observed defect or reaction.

It is not, of course, intended to interfere with any national system or to act as an extra stage between the user and the manufacturer.

Therefore: Report to

- a. national authorities or society, if required
- b. the manufacturer of the radiopharmaceutical
- c. the European Joint Committee on this form.

When a report has been received by the Joint Committee a receipt and a new report form will be sent. By contact to the secretariat: Knud Kristensen, The isotope-Pharmacy, Frederikssundsvej 378, DK-2700 Brønshøj, Denmark. Phone: (02) 94 37 73. Telex: 35333 (pharm dk), information can be obtained about any similar reaction, that may have been reported earlier. The data submitted will be treated as confidential and the originator will not be identified in any report without written permission.

The Joint Committee will issue an annual report, that will include all data in an anonymous form. If justified by the nature of the data received an urgent publication will be made. The annual report will be made public by the two societies and a copy of the report will be sent directly to all those who participated.

Adverse reaction is here taken to include all unexpected patient reactions. Such reactions should be reported even if the probability of a relationship between administration of the radiopharmaceutical and the reaction seems small. If other causes seem more likely (e.g. administration of other pharmaceuticals) these should be mentioned in the description.

The term 'Drug Defects' is used here to define all variations from product specifications, from normal appearance of packaging or from the expected biological behaviour of the radiopharmaceutical.

It is of great importance that as many details as possible are reported.

If the radiopharmaceutical was 'home-made' the reporting department should be given as the manufacturer and details provided with regards to specifications, preparation methods, quality control etc.

In order to be able to identify as far as possible a causal relationship the following details should always be covered in the report:

- Purpose of the investigation or treatment
- Patient condition when the product was administered
- Volume administered, route of administration etc.
- Detailed description of the reaction including clinical findings, physiological measurements and laboratory results
- Time course of the incident
- Treatment given to overcome the reaction
- Consequences of the reaction to the patient
- Reactions of other patients given the same product

Figure 20.3. Form (front, page 308; back, this page) distributed by the Joint Committee on Radiopharmaceuticals for reporting adverse reactions and defects associated with radiopharmaceuticals; this form is used by several European countries, and the data are pooled.

reactions to radiopharmaceuticals (13). The United States data have been published in the *Journal of Nuclear Medicine* or other appropriate journals from time to time (10, 13–15).

Reporting systems have been developed in other countries also. Japan, for example, has had an ongoing system for several years. Europe has systems in the United Kingdom, West Germany, and Denmark. In addition, the Joint Committee on Radiopharmaceuticals of the European Nuclear Medicine Society and the Society of Nuclear Medicine-Europe set up a system in 1979 to monitor defects in radiopharmaceuticals and adverse reactions associated with their use in Europe (16). Reports from the Joint Committee have been published in the *European Journal of Nuclear Medicine* as well as *Nuklearmedizin* (17–20).

Forms used in the United States, the United Kingdom, and Europe to document suspected adverse reactions associated with radiopharmaceuticals have been reproduced as Figures 20.1, 20.2, and 20.3. In the European system (Figure 20.3), the form can be used to report drug defects as well as adverse reactions and thus serves two purposes. In the United States, drug product problems are now reported on a form separate from adverse reactions (form FDA 3318).

STATISTICS ON REPORTED REACTIONS

Several review articles and chapters have summarized early data on adverse reactions attributed to the administration of radiopharmaceuticals (4, 9). The present chapter, on the other hand, deals almost exclusively with data from the post-1976 years. This time period was selected partly because it coincides with the establishment of the new SNM adverse reaction registry (first modification) and partly because of the many changes in nuclear medicine that have occurred over the past 10 years. For instance, a high percentage of the current armamentarium of radiopharmaceuticals has been introduced (or come into widespread use) only since 1976, and a few of the older radioactive drugs have faded from use during this time. Moreover, improvements in quality control

measures have all but eliminated the problems that were previously encountered with pyrogens. As a result of these and other factors, the mix of adverse reactions have changed somewhat over the years and, depending on radiopharmaceutical usage patterns and current manufacturing practices, continues to change (21).

It is worth noting that, routinely, more adverse reactions are reported directly to the FDA by the manufacturers of radiopharmaceutical drug products than by individual practitioners using the volunteer system endorsed by SNM. This is partly because when a clinician notes a suspected adverse effect, he or she often turns to the manufacturer to inquire whether the effect has been previously observed. Because of legal requirements the manufacturer must subsequently report the suspected reaction to the FDA, whereas under the volunteer reporting system the clinician may or may not further document the reaction. *All of the United States data given in this chapter are obtained from practitioners' reports to the SNM and not from manufacturers' reports to the FDA.*

Table 20.1 is a compilation of adverse reactions that were reported to the SNM for each radiopharmaceutical during the years 1976 through the end of 1984. There were 356 adverse reactions reported by use of the SNM Drug Problem Report form over this 9-year period. Of these, 24% were attributed to ^{99m}Tc -labeled sulfur colloid, 19% to ^{99m}Tc -labeled human albumin microspheres (HAM), and 10% to ^{99m}Tc -methylene diphosphonate (MDP). ^{99m}Tc -labeled macroaggregated albumin (MAA), ^{99m}Tc -glucoceptate, ^{99m}Tc -pyrophosphate, ^{99m}Tc -diethylenetriaminepentaacetic acid (DTPA), [^{67}Ga]gallium citrate, and [^{131}I]iodomethylnorcholesterol, accounted for another 4–5% each of the reported reactions.

The proportion of reactions reported for ^{99m}Tc -labeled sulfur colloid decreased from 28%, for the years 1976 through 1979, to 19%, for the years 1980 through 1984. Conversely, the relative percentage of reactions attributable to phosphate and phosphonate agents increased from 14% in the earlier period (1976–1979) to 20% in the more recent period (1980–1984). ^{99m}Tc -MDP, in particular, rose from 5% to 15% of the total between the two time periods; the

Table 20.1.
Reported Adverse Reactions to Radiopharmaceuticals in the United States, from 1976 through 1984*

Radiopharmaceutical	No. of Reports by Year									Total
	1976	1977	1978	1979	1980	1981	1982	1983	1984	
^{99m}Tc -labeled sulfur colloid	11 (7)†	19 (10)	13 (12)	11	13	5	7	2	3	84
^{99m}Tc -labeled human albumin microspheres (HAM)	19	14	16	6	4	1		4	4	68
^{99m}Tc -medronate (MDP)		3	1	6	7	5	4	2	7	35
[^{67}Ga]gallium citrate	1				4	5	4	2		16
^{99m}Tc -pyrophosphate (PYP)	10 (9)	2	2	1	1					16
^{99m}Tc -glucoceptate	2	2 (1)	2	1	2	1	4	1	1	16
^{99m}Tc -labeled macroaggregated albumin (MAA)	1	1	2	2	3	3	3			15
[^{131}I]iodomethylnorcholesterol	2		3	1	2	5		1		14
^{99m}Tc -pentetate (DTPA)	1	3		3	2	1		1	3	14
Sodium [^{131}I]iodide	2	1	2	1				1	1	8
Nonradioactive pyrophosphate kit						1	4	1	1	7
^{99m}Tc -oxidronate (HDP)						4	2	1		7
<i>o</i> -[^{131}I]iodohippurate	1				3	2	1			7
^{99m}Tc -labeled human serum albumin (HSA)	1	1	2	1	1					6
^{111}In -pentetate (DTPA)	2		1	1	1			1		6
^{99m}Tc -ferretate	1	3 (1)	1							5
[^{201}Tl]thallous chloride		1			2		2			5
Sodium [^{99m}Tc]pertechnetate	1	1				1	1			4
^{131}I -labeled rose bengal	2	1	1							4
^{99m}Tc -disofenin (DISIDA)						2		2		4
^{99m}Tc -succimer (DMSA)	2						1		1	4
^{99m}Tc -etidronate (HEDP)	1		1							2
^{169}Yb -pentetate (DTPA)						2				2
Sodium [^{32}P]phosphate				1						1
^{99m}Tc -lidofenin (HIDA)						1				1
^{99m}Tc -butilfenin (BIDA)							1			1
^{99m}Tc -iprofenin (PIPIDA)							1			1
Sodium [^{123}I]iodide							1			1
^{51}Cr -labeled human serum albumin (HSA)								1		1
Red blood cells labeled in vitro with ^{99m}Tc									1	1
Total	60	52	47	35	45	39	36	20	22	356

* The probability that a reported adverse reaction was associated with administration of the radiopharmaceutical has been evaluated for the years 1976 through 1981 (see Ref. 10).

† Numbers in parentheses indicate number of reports. Sometimes more than one case per report is cited.

increase is doubtless partially due to a higher utilization of this agent.

Interestingly, the number of reactions reported in the United States during 1983 and 1984 is approximately one third (37%) of the number of reactions reported in 1976 and 1977. Unfortunately, it is impossible to determine whether this drop reflects a true reduction in the

incidence of reactions or an increased apathy toward the reporting of these adverse effects.

In the United Kingdom, 61 reactions were reported during the 7 years spanning 1977 through 1983 (see Table 20.2) (21). Colloids (33%), phosphonates (28%), and albumin particulates (13%) were the most frequently cited offenders. The number of colloid- and phospho-

Table 20.2.

Major Groupings of Adverse Reactions to Radiopharmaceuticals in the United Kingdom, 1977-1983

	Colloids	Phosphonates	Albumin Particulates	Others	Subtotals
January 1977-mid-1980	12 (12) 48%	2 (2) 8%	5 (4) 16%	8 (7) 28%	27 (25) 100%
Mid-1980-December 1983	8 (6) 21%	15 (13) 45%	3 (3) 10%	8 (7) 24%	34 (29) 100%
Total	20 (18) 33%	17 (15) 28%	8 (7) 13%	16 (14) 26%	61 (54) 100%

* Numbers in parentheses are totals less those considered as "unlikely" to be associated with the radiopharmaceutical. (Adapted from D. H. Keeling and C. B. Sampson: Adverse reactions to radiopharmaceuticals. United Kingdom 1977-1983. *Br. J. Radiol.* 57:1091-1096, 1984, with permission.)

nate-associated reactions showed trends qualitatively similar to, although quantitatively more dramatic than, those found in the United States series. Colloids accounted for 48% of the total reactions reported from 1977 through mid-1980 but for only 21% of these reactions from mid-1980 through 1983. Phosphonates, on the other hand, made up only 8% of the reports for 1977-80 but 45% of the reports in the more recent period (21).

Over the 4-year period from 1980 through 1983, 75 adverse reactions were reported to the European Joint Committee on Radiopharmaceuticals (see Table 20.3) (17-20). Phosphonates and (various) colloids ranked as the top two radioactive drug categories for which reactions had been reported, with radioiodinated cholesterol a close third. It is not surprising that these statistics agree with the United Kingdom series, because 44% of all the European data is from the United Kingdom alone. Collectively, these three radiopharmaceuticals (colloid, phosphonates, cholesterol) account for 52% (39 of 75) of all the reactions reported to the Joint Committee. The remaining 36 reactions involved 23 different radiopharmaceuticals (17-20).

According to the United States literature (14), the majority of adverse reactions occurring during the years 1976-1979 were minor (resolved with no therapy) or intermediate (requiring some form of therapy for relief but not life-threatening). Severe reactions involving anaphylactic shock or cardiac arrest were reported in only 3% of cases. In 52% (39 of 75) of the cases reported to the European Joint Committee, treatment was required (17-20).

Nuclear medicine studies often are performed on critically ill patients; thus, occasionally a

patient may expire during the procedure or shortly after the procedure is completed. Sometimes, it is very difficult to determine the exact role that the radiopharmaceutical may have had in the patient's death.

Three deaths have been reported through the United Kingdom reporting system (11, 21). One death was associated with a hypotensive reaction following the injection of a colloidal radiotracer in a severely ill patient. Another patient apparently died from a subarachnoid hemorrhage shortly after the intravenous injection of ^{99m}Tc -pertechnetate. The third fatality was reported to have occurred 3 days following the injection of ^{99m}Tc -labeled human serum albumin millimicrospheres; although a higher-than-normal amount of the drug was retained in the lung field, no immediate problem was observed. In the first of these events, the hypotensive episode may be associated with the administration of radiocolloid, since this type of reaction has been observed previously following intravenous dosing of radiopharmaceuticals. On the other hand, it is very difficult to find a logical connection between the other two deaths and the radiopharmaceuticals administered.

The European Joint Committee has reported on two deaths (17-20). One patient died after cardiac arrest which occurred 1 hour after the injection of ^{67}Ga -citrate,* and the other patient died within hours after the administration of ^{99m}Tc -MAA and ^{99m}Tc -pertechnetate. In neither instance is there a strong reason to believe that

* Although [^{67}Ga]gallium citrate and [^{99m}Tc]pertechnetate are preferred by IUPAC, ^{67}Ga -citrate and ^{99m}Tc -pertechnetate are standard, and both are used throughout this chapter.

Table 20.3.

Adverse Reactions to Radiopharmaceuticals Reported to the European Joint Committee on Radiopharmaceuticals, 1980-1983

Radiopharmaceuticals	No. of Reports by Year				
	1980	1981	1982	1983	Total
^{99m}Tc -labeled SbS colloid	1	1	2	1	5
^{99m}Tc -labeled RhS colloid	1				1
^{99m}Tc -labeled sulfur colloid	1				1
^{99m}Tc -labeled tin colloid			1		1
^{99m}Tc -labeled human serum albumin	1		2		3
^{99m}Tc -labeled microspheres	1	1	1		3
^{99m}Tc -labeled millimicrospheres	2				2
^{99m}Tc -DTPA		1			1
^{99m}Tc -MDP	4	3	3	3	13
^{99m}Tc -HDP				1	1
^{99m}Tc -MAA			1	1	2
^{99m}Tc -MAA and ^{99m}Tc -pertechnetate				1	1
^{99m}Tc -pertechnetate				1	1
^{99m}Tc -labeled plasmin			1		1
[^{51}Cr]chromate and [^{125}I]HSA	1				1
^{51}Cr -EDTA		1	1		2
^{67}Ga -citrate	1	1	2		4
^{75}Se -cholesterol				3	3
Sodium [^{123}I]iodide		1			1
^{123}I -labeled fatty acid			1		1
^{123}I -isopropylamphetamine				1	1
[^{123}I]iodohippurate	1				1
[^{125}I]iodohippurate and [^{131}I]iodohippurate	1	1			2
Sodium [^{131}I]iodide			1		1
^{131}I -labeled cholesterol	9	1			10
[^{131}I]iodohippurate			1		1
^{198}Au -labeled colloid	1		2		3
^{131}I -labeled HSA cisternography		1	1		2
^{169}Yb -DTPA cisternography		3			3
^{111}In -DTPA cisternography		1			1
^{111}In -labeled colloid			1		1
^{111}In -labeled platelets			1		1
Total	25	16	22	12	75

there is a cause-effect relationship between the deaths and the use of the radiopharmaceuticals.

CHARACTERISTICS OF ADVERSE REACTIONS TO SPECIFIC RADIOPHARMACEUTICALS

Most reported adverse reactions have been allergic in nature (10, 14, 17-20). Vasovagal reactions account for much of the remainder, along with a few miscellaneous adverse effects such as pyrogen reactions, aches and pains, vomiting, and headache unrelated to pyrogens.

Several publications have listed some of the clinical manifestations that are commonly observed with adverse reactions to specific radiopharmaceuticals (10-12, 14). For those radiopharmaceuticals on which enough data are available, it is noteworthy that in reported cases, single clinical manifestations or, sometimes, a pattern of symptoms occurs again and again. Even so, with the exception of only a very few radioactive drugs (e.g., possibly ^{99m}Tc -labeled human albumin microspheres or [^{131}I]iodomethylnorcholesterol, there is no such thing as a "typical" adverse reaction.

The relationship between the reactions reported for a specific radiopharmaceutical and the source of that radiopharmaceutical was examined with use of the SNM reports for ^{99m}Tc-MDP (13 reports) and ^{99m}Tc-labeled sulfur colloid (12 reports) for the years 1982 through 1984. Even with this limited amount of data, it is apparent that no single company is cited in all adverse reaction reports for either of these radiopharmaceutical products, nor can any manufacturer be blamed for a special type of reaction. Likewise, there is no correlation between the source of ^{99m}Tc-pertechnetate (generator) used

to prepare the reagent kit and the reported reactions. Specifically, with ^{99m}Tc-MDP, four kit sources and three sources of ^{99m}Tc-pertechnetate (six different combinations of kit-pertechnetate) were cited; with ^{99m}Tc-labeled sulfur colloid, four kit sources, three generator sources, and seven combinations of kit-pertechnetate were cited. Data collected during these same years for other multisource products are too scant to be credibly analyzed.

Table 20.4 lists the clinical manifestations encountered with suspected reactions to the six most frequently cited radiopharmaceuticals, as

Table 20.4.
Description or Adverse Reactions to Six Radiopharmaceuticals Reported to the Society of Nuclear Medicine, January 1982–December 1984

Radiopharmaceutical	Clinical Manifestations of Reaction	Time of Reaction Onset	Treatment Required?
^{99m} Tc-MDP	1. Rash; itching	40 min	Yes
	2. Rash; itching	36 hr	?
	3. Rash; itching	10 hr	Yes
	4. Itching	4 hr	Yes
	5. Itching	2 hr	Yes
	6. Upper body flushing; single petechial area two inches from injection site	30 min	No
	7. Pyrexia; edema in extremities; red blotchy skin	4–8 hr	No
	8. Sore throat; rash; ?Stevens Johnson syndrome	48 hr	Yes
	9. Vomiting 3 times within a 3-hr period	40 min	No
	10. Generalized pruritis; welts and itching "bumps"	8–10 hr } 48 hr }	Yes
	11. Cardiac arrhythmia; died (details are sketchy)	2 hr	Died
	12. Rash; chills	1 hr	Yes
	13. Dizziness; nausea	5 min	No
^{99m} Tc-labeled sulfur colloid	1. Maculopapular rash on upper trunk and extremities; itching	30 min	Yes
	2. Allergic reaction (no details given)	15 min	Yes
	3. Urticaria; swelling of extremities	8 hr	Yes
	4. Rash; tightness in throat	10 min	Yes
	5. Flushing; shortness of breath; coughing; itching in palms, antecubital spaces and throat	10 min	Yes
	6. Rash of neck; abdominal discomfort	6 hr	Yes
	7. Urticaria	30 min	Yes
	8. Laryngospasm or laryngeal edema	2 min	Yes
	9. Whole-body rash	24 hr	No
	10. Tingling of extremities; tightness in chest and throat; increased blood pressure; tachycardia; maculopapular rash	15 min	Yes
	11. Itching; swelling of face and extremities; blisters on face	4–6 hr	Yes
	12. Chills; fever; felt "shaky"; increased blood pressure	4–6 hr	No

Table 20.4—continued

Radiopharmaceutical	Clinical Manifestations of Reaction	Time of Reaction Onset	Treatment Required?
^{99m} Tc-labeled human albumin microspheres	1. Itching	3 min	Yes
	2. Flushing; decreased blood pressure	immediately	No
	3. Flushing of face; epigastric discomfort	2 min	No
	4. Facial "burning"; nausea; tightness in chest; severe lower abdominal pain	1 min	No
	5. Flushing immediately; chills and fever within 30 min	1 min	No
	6. Flushing; urticaria; diaphoresis	3 min	No
	7. Flushing of face; shortness of breath; right-upper-quadrant pain	3 min	No
	8. Circumoral cyanosis; lethargy; spasms of extremities	5 min	No
^{99m} Tc-gluceptate	1. Pupil dilatation; general tonic convulsions; bradycardia (probably all related to very recent excessive alcohol and drug abuse)	? "shortly"	No
	2. Flushing of face, trunk and arms; weakness	immediately	No
	3. Numbness; palpitation; difficulty in breathing	1 min	No
	4. Urticaria on face, chest, and back	10 min	Yes
	5. Urticaria	1 hr	No
	6. Allergic reaction (no details given)	15 min	Yes
Nonradioactive pyrophosphate reagent kit	1. Diaphoresis; bronchospasm	1 min	Yes
	2. Decreased blood pressure; dizziness; blurred vision; tightness in chest; nausea	10 min	Yes
	3. Generalized pruritis; hives on upper thighs	7 hr	Yes
	4. Wheezing; decreased pO ₂	10 min	Yes
	5. Rash; itching	30 min	Yes
	6. Chills; joint pain; nausea; dizziness; fever (which may be due to bacteremia from indwelling intravenous line, but cultures were not performed)	20 min	Yes
⁶⁷ Ga-citrate	1. Morbilliform rash on trunk and flexor surfaces of extremities; itching	24 hr	No
	2. Hives on right forearm and shoulder	10 min	Yes
	3. Inflammation at site of injection; rash around mouth and on neck	immediately	Yes
	4. Erythematous, maculopapular rash on entire body	15 min	No
	5. Tachycardia; hives	3 hr	Yes
	6. Rash and pruritis on left forearm	12 hr	Yes

reported to the SNM adverse reaction registry during the years 1982 through 1984. In development of this table, there was no attempt to determine the probability of whether the observed reaction was actually caused by the administered radiopharmaceutical. Characteristics of reactions to individual radiopharmaceuticals are briefly discussed below.

Colloids

As mentioned previously, ^{99m}Tc-labeled sulfur colloid has been responsible for the largest number of adverse reactions reported to the SNM. Even though the total number is high, however, the incidence of reactions is not much greater than the average for all radiopharmaceuticals combined, since ^{99m}Tc-labeled sulfur col-

loid is administered so frequently (14, 15). Since 1976, the majority of adverse reactions to ^{99m}Tc -labeled sulfur colloid reported in the United States have been allergic in nature, with rash, urticaria, pruritis, dyspnea, and nausea and vomiting being the most frequent symptoms (10, 14). From 1976 to 1981, anaphylactic or anaphylactoid reactions accounted for 8% of the total (10). In the United Kingdom, reactions involving vasomotor changes, along with localized discomfort, headache, and backache, were common, and reactions such as dyspnea and bronchospasm occurred in a small number of patients (21).

Before 1976, colloids of ^{198}Au and ^{113m}In were also used for liver and/or spleen imaging. Allergic reactions occasionally were reported for these agents, although a more serious problem with use of the ^{198}Au was the potential for an accidental radiation overdose.

Albumin Particulates

Macroaggregates or microspheres of albumin labeled with ^{99m}Tc are the two most commonly used agents in the United States for pulmonary and arterial perfusion studies. In 1978 and 1979, the only years for which data on the incidence in the United States are available, ^{99m}Tc -labeled human albumin microspheres had the highest incidence of adverse reactions of any radiopharmaceutical (14, 15). The clinical manifestations reported most frequently were flushing associated with dyspnea and/or shortness of breath, with or without other allergic symptoms (10, 14). Anaphylactic or anaphylactoid reactions occurred in 10.1% of the reported cases from 1976 through 1981 (10).

By comparison, the incidence of adverse reactions to the more commonly used ^{99m}Tc -labeled macroaggregated albumin was about 15–20-fold less than that observed for ^{99m}Tc -labeled albumin microspheres (14, 15). Reported symptoms included flushing, tachycardia, syncope, and rash (10, 14).

Adverse reactions to albumin particulates may be attributed to either antigenic reactions or vascular obstruction in the lungs. These particles are trapped by the precapillary arterioles and capillaries of the lungs where they are essentially microemboli. In a person with normal

pulmonary function, only 0.2–0.3% of the vessels are blocked with a 1-mg dose of protein consisting of particles ranging from approximately 20 to 90 μm (22, 23). This small fraction normally will not cause a problem clinically. In a patient with diminished functional capacity of the pulmonary vasculature, however, the added insult could be significant (12).

Iron hydroxide precipitates were used for lung imaging until 1973. At that time, the United States Atomic Energy Commission and the British Institute of Radiology (BIR) advised discontinuing their use due to numerous adverse reactions, including three deaths, associated with the administration of these agents. The reactions may have been caused by free ferric hydroxide ion which has an indirect vasoconstricting effect (4, 9).

Phosphates and Phosphonates

Although virtually all of the ^{99m}Tc -labeled phosphate and phosphonate agents have been implicated in reports of adverse reactions, ^{99m}Tc -MDP has received the most notoriety. A reaction that is repeatedly observed with ^{99m}Tc -MDP involves a late-onset rash and/or itching which appears 2–24 hours or longer after injection and persists for several days (10, 11). This phenomenon has been mentioned in 15 of 35 reports of reactions to ^{99m}Tc -MDP in the United States series. This type of reaction has been carefully documented in one report in the United States literature (24), and in the United Kingdom series, British authors have noted several instances of a similar reaction (11, 21). Other adverse reactions to ^{99m}Tc -MDP include miscellaneous symptoms such as flushing, headache, swelling of the extremities, and nausea and vomiting (10). There were two reports of broken blood vessels in the eye following administration of ^{99m}Tc -MDP (10). The probability that this occurrence was caused by ^{99m}Tc -MDP is low (10), but it is unusual that a patient in the United Kingdom also developed a severe visual disturbance shortly after the injection of this same radiopharmaceutical (21).

Pyrophosphate injected both with and without the ^{99m}Tc label has been associated with a significant number of reactions in the United States. Clinical manifestations were similar re-

gardless of whether the ^{99m}Tc label was present; symptoms have included rash, dizziness, nausea, and bronchospasm.

[^{131}I]Iodomethylnorcholesterol

[^{131}I]Iodomethylnorcholesterol, which is used for adrenal cortex imaging, has been associated with adverse reactions characterized by shortness of breath, tightness in the chest, palpitations, vasodilatation, nausea, and dizziness persisting for 5–20 minutes postinjection. The manufacturer has attributed the reaction to the Tween-80 surfactant used in the product formulation (25). Specifically, it has been reported that polyoxyethylene sorbitan fatty acid esters (i.e., Tweens) have been shown to release histamine from endogenous sources following intravenous administration (26, 27). The reactions experienced with [^{131}I]iodomethylnorcholesterol are consistent with the effects of histamine on the cardiovascular and pulmonary systems (25).

Cisternographic Agents

Historically, intrathecal radionuclide cisternographic preparations were once one of the most frequent causes of adverse effects due to the incidence of aseptic meningitis associated with their use. These radiopharmaceuticals, [^{131}I]labeled human serum albumin and, later, [^{111}In]DTPA, were originally tested with use of the standard United States Pharmacopeia rabbit test for pyrogens. Not until the introduction of the limulus amoebocyte lysate (LAL) test for endotoxins, however, did it become apparent that these radiopharmaceuticals were, in fact, contaminated with pyrogens at a level not detected by the rabbit test (9, 12). It was found that the source of the endotoxin, in the case of the radioiodinated compounds, was the anion exchange column used to remove unbound iodine. In the DTPA preparations, the phosphate buffer was the component that contained the endotoxin (12). Once the problem was identified and the source of the pyrogens ascertained, the incidence of aseptic meningitis associated with these products was drastically reduced (9), and the incidence has remained extremely low in recent years.

INCIDENCE OF ADVERSE REACTIONS

One of the objectives of the SNM registry and other reporting systems is to obtain current incidence data for adverse reactions to radiopharmaceuticals in order to help assess whether there is a problem with a specific drug. These data are generated by first multiplying the estimated number of total radiopharmaceutical administrations in a given time period by the relative frequency of use for a particular radiopharmaceutical in that same time period. The number of adverse reactions to the radiopharmaceutical is then divided by this figure to derive incidence data. Because it is estimated that only one tenth to one half of the observed reactions are actually reported, a range is estimated by use of the following equation (14):

Estimated range of adverse reactions

$$= \frac{2N}{f(A)} \text{ to } \frac{10N}{f(A)} \quad \text{Equation 21.1}$$

where N equals the number of reported reactions, f equals the relative frequency of use of an individual radiopharmaceutical, and A equals the total number of administrations of all radiopharmaceuticals.

Reports by the SNM subcommittee on adverse reactions indicated that the incidence in the United States is between 1/100,000 and 6/100,000 administrations. The estimates for the United States ranged from 8.8/100,000 administrations for ^{99m}Tc -labeled human serum albumin to 0.12/100,000 for ^{99m}Tc -MDP in 1978 and from 5.4/100,000 for ^{99m}Tc -labeled human albumin microspheres to 0.25/100,000 for ^{99m}Tc -glucaptate in 1979 (14, 15).

This estimate is lower than that reported by Sampson and Keeling (28) in 1982 for 32 nuclear medicine centers in the United Kingdom; the figures ranged from 1 reaction in 400 (250/100,000) for ^{99m}Tc -labeled macroaggregated albumin to 1 reaction in 4,250 (24/100,000) for ^{99m}Tc -pertechnetate (28). This was a reduction in incidence from a preliminary survey report of United Kingdom data by Williams (29) in 1974 who estimated from 1 reaction/36 administrations (2,788/100,000) for ^{99m}Tc -labeled macroaggregated albumin to 1/3,000 (33/100,000) for ^{99m}Tc -DTPA.

Williams (29), however, used a questionnaire to obtain data based on the recent and retrospective experience of 40 individuals, whereas Sampson and Keeling (28) used data based only on recent experience. Therefore, the incidence data from the earlier survey may not be as reliable as that from the follow-up report.

Extrapolating from data obtained in their respective districts, Keeling and Sampson (21) have even more recently estimated an overall incidence in the United Kingdom of approximately 10–40 reactions/100,000 tests. Results from a series of reports from Japan indicate that reactions to radiopharmaceuticals occur at a rate of 6–20/100,000 administrations, with the exception of [¹³¹I]iodocholesterol which has an adverse reaction rate of approximately 3–5/1,000 (17, 18).

Regardless of the source, incidence figures for radiopharmaceuticals appear to be, in general, much less than those given for therapeutic drugs or contrast media (30–33). That adverse reactions occur much less often with radiopharmaceuticals than with contrast agents may sometimes influence the selection of the diagnostic imaging procedure of choice for a critically ill patient.

VALIDATION OF ADVERSE REACTIONS

In most systems, it is recommended that any adverse experience associated with the drug, even if that association is not certain, should be reported. Therefore, the validity of these anecdotal reports is sometimes questioned by both professionals and manufacturers. Venning (34) has suggested that "any regulatory agency using anecdotal reports of suspected reactions as a basis for an early warning system will need to develop criteria for assessing the validity of such reports." Therefore, reports submitted to the SNM for the years 1976 through 1981 were evaluated (10) with use of a modified algorithm based on one developed by Kramer et al. (35) for the assessment of adverse drug reactions. The algorithm was used to analyze each case in an accurate and reproducible fashion by systematically and objectively deriving a score for the probability of an adverse reaction occurring. Criteria for evaluating adverse reactions to ra-

diopharmaceuticals included (a) previous experience with the radiopharmaceutical including the frequency with which a specific reaction to the radiopharmaceutical was reported, (b) the possibility (probability) of other etiologic candidates for the reaction or of an exacerbation or recurrence of the underlying disease, (c) the timing of the adverse reaction in relation to the administration of the radiopharmaceutical, (d) whether or not there was improvement after dechallenge, and (e) whether or not there was a recurrence of the reaction following rechallenge with the radiopharmaceutical. Adverse reactions were then classified, depending on the score derived from the algorithm, as definite, probable, possible, or unlikely. With use of this method, adverse reactions to radiopharmaceuticals were determined to be definite in 47 of 277 cases (17%), probable in 111 cases (40%), possible in 100 cases (36%), and unlikely in 19 cases (7%) (10). Keeling (11) and Keeling and Sampson (21) have subjected data from the United Kingdom to a similar analysis and found that 7 of the 61 reported reactions were unlikely to be directly related to the administration of the radiopharmaceutical.

It is obvious from the SNM experience that there are some inherent problems in evaluating anecdotal information. One of the major drawbacks is that in some cases, the reports are incomplete, either because the reporter did not fill in all of the information on the form (or did not give enough detail) or because there are inherent limitations with the reporting form itself. For instance, not until 1985 did the report form used for radiopharmaceuticals (FDA 1639) ask the reporter to list the patient's current medications and allergic history. This type of information would have been (and will be) useful in helping to determine whether there was an alternative etiology for the reaction. In defense of the original reporting form (FDA 2822), it is only fair to mention that the form was intentionally designed in a relatively simple format so that a majority of people would be willing to take the time to complete it after witnessing an adverse reaction. Reporters were (and still are) encouraged, however, to give additional information (not specifically requested on the form) and to elaborate on specific cir-

cumstances or events that may be relevant to the reaction. Some of the procedures that should be followed in the investigation and reporting of a suspected adverse reaction have been described by Rhodes and Wagner (36). Complete and accurate data always make the task of determining the validity of the reaction much easier.

It should be noted that the most definitive way to determine whether a type B adverse reaction to a drug has occurred is by rechallenging the patient with the suspected offender. Rechallenge may occur either by chance or by direct intervention when this is ethically justified. In most cases, rechallenge with radiopharmaceuticals is not attempted. There have been a few cases reported to the SNM, however, in which a person who had experienced an allergic response to a radiopharmaceutical was subsequently injected with the same radiopharmaceutical and experienced the same allergic response. This was reported in two separate instances of adverse reactions to ^{99m}Tc-labeled sulfur colloid. In a case involving ^{99m}Tc-MDP, the patient had identical reactions 1 month apart (24). A similar, but more severe, reaction occurred in one patient following a repeat administration of ^{99m}Tc-labeled human albumin microspheres 2 days after the first injection. In 1982, the SNM received a report of rechallenge by direct intervention with pyrophosphate reagent kit, in which a topical patch test was performed on a patient who had experienced generalized pruritis and urticaria following administration of 6 mg of pyrophosphate (reagent kit) in preparation for a radionuclide ventriculography study. The reporter in this case first performed a patch test for stannous chloride, which was negative. This was followed by a patch test for the reagent kit contents (pyrophosphate plus stannous chloride), which elicited a positive response.

SUMMARY

The overall incidence rate for radiopharmaceuticals is estimated to be less than 40/100,000 administrations. Reactions are most commonly associated with particulate carriers such as denatured albumin or colloidal material, as well as the soluble carriers containing phosphonates or iodomethylnorcholesterol. At times, the reac-

tions may be caused by the pharmaceutical additives (e.g., surfactants) found in these radiopharmaceutical preparations rather than by the primary carrier itself.

Most reactions appear to be allergic in nature. In addition, the majority occur within minutes following the administration of the radiopharmaceutical, with the notable exception of the late rashes observed with the phosphonate bone imaging agents.

Adverse reaction reporting systems in which anecdotal information is utilized to document adverse effects to radiopharmaceuticals suffer generally from poor participation and incomplete reporting. If the adverse reaction registries are going to be of utmost value to the nuclear medicine "community," the cooperation of all professionals in the field is needed. Suspected reactions should be promptly reported, and care should be taken to provide complete and pertinent facts on each case. Only then can the objectives of the established systems, i.e., to alert practitioners to potential problems as early as possible and to determine accurate incidence data, be met.

REFERENCES

1. United States Federal Food Drug and Cosmetic Act, Chapter II (Definitions), Sec 201 [321] (g) (1).
2. United States Code of Federal Regulations, Title 21, Part 310.301 (b).
3. Atkins HL: Adverse reactions. In Rhodes BA (ed): *Quality Control in Nuclear Medicine*. St Louis, CV Mosby, 1977, pp 263–267.
4. Blaha V, Colombetti LG: Adverse Reactions to radiotracers. In Colombetti LG (ed): *Principles of Radiopharmacology*. Boca Raton, FL, CRC Press, 1977, pp 165–177.
5. Shani J, Sarel O, Rogel S, et al: Comparative cardiac effects of three hepatobiliary radiopharmaceuticals in the dog: concise communication. *J Nucl Med* 23:337–341, 1982.
6. Ahmed SR, Shalet SM: Radioactive iodine and testicular damage. *N Engl J Med* 311:1576, 1984.
7. Ahmed SR, Shalet SM: Gonadal damage due to radioactive ¹³¹I treatment for thyroid carcinoma. *Postgrad Med J* 61:361–362, 1985.
8. Rawlins MD, Thompson JW: Pathogenesis of adverse drug reactions. In Davies DM (ed): *Textbook of Adverse Drug Reactions*, ed 2. Oxford, Oxford Medical Publications, 1981.
9. Shani J, Atkins HL, Wolf W: Adverse reactions to radiopharmaceuticals. *Semin Nucl Med* 6:305–328, 1976.
10. Cordova MA, Hladik WB III, Rhodes BA: Validation

- and characterization of adverse reactions to radiopharmaceuticals. *Noninvasive Med Imaging* 1:17-24, 1984.
11. Keeling DH: Adverse reactions to radiopharmaceuticals. In Kristensen K, Norbygaard E (eds): *Safety and Efficacy of Radiopharmaceuticals*. The Hague, The Netherlands, Martinus Nijhoff, 1983, pp 240-250.
 12. Keeling DH: Side effects associated with the use of radiopharmaceuticals. In Gorrod JW (ed): *Drug Toxicity*. London. Taylor & Francis Ltd., 1979, pp 285-295.
 13. Ford L, Shroff A, Benson W, et al: SNM drug problem reporting system. *J Nucl Med* 19:116-117, 1978.
 14. Cordova MA, Rhodes BA: Adverse reactions to radiopharmaceuticals: incidence in 1978, and associated symptoms. Report of the adverse reactions subcommittee of the Society of Nuclear Medicine. *J Nucl Med* 21:1107-1110, 1980.
 15. Cordova MA, Rhodes BA, Atkins HL, et al: Adverse reactions to radiopharmaceuticals. *J Nucl Med* 23:550-551, 1982.
 16. Round table discussion on radiopharmaceuticals: reporting of adverse reactions and drug defects. *Nuklearmedizin* 20:10-12, 1981.
 17. The Joint Committee on Radiopharmaceuticals of the European Nuclear Medicine Society and the Society of Nuclear Medicine—Europe: The system for "reporting of adverse reactions and drug defects" (1980-1982)—first report. *Nuklearmedizin* 21:274-277, 1982.
 18. The Joint Committee on Radiopharmaceuticals of the European Nuclear Medicine Society and the Society of Nuclear Medicine—Europe: First report on the system for "reporting of adverse reactions and drug defects" 1980-1982. *Eur J Nucl Med* 9:45-49, 1984.
 19. The Joint Committee on Radiopharmaceuticals of the European Nuclear Medicine Society and the Society of Nuclear Medicine—Europe: European system for reporting of adverse reactions and drug defects—second report 1982-1983. *Nuklearmedizin* 23:107-108, 1984.
 20. The Joint Committee on Radiopharmaceuticals of the European Nuclear Medicine Society and the Society of Nuclear Medicine—Europe: European system for reporting of adverse reactions and drug defects: second report 1982-1983. *Eur J Nucl Med* 9:388-389, 1984.
 21. Keeling DH, Sampson CB: Adverse reactions to radiopharmaceuticals. United Kingdom 1977-1983. *Br J Radiol* 57:1091-1096, 1984.
 22. Harding LK, Horsfield K, Singhal SS, et al: The preparation of lung vessels blocked by albumin microspheres. *J Nucl Med* 14:579-582, 1973.
 23. Davis M: Particulate radiopharmaceuticals for pulmonary studies. In Subramanian G, Rhodes BA, Cooper JF, Sodd VJ (eds): *Radiopharmaceuticals*. New York, Society of Nuclear Medicine, 1975, pp 267-281.
 24. Spicer JA, Preston DF, Stephens RL: Adverse allergic reaction to technetium-99m methylene diphosphonate. *J Nucl Med* 26:373-374, 1985.
 25. Swanson DP: Adverse reactions to NP-59 (personal communication to all investigators of [¹³¹I]iodomethylnorcholesterol, May 8, 1980.)
 26. Marks LS, Kolmen SN: Tween 20 shock in dogs and related fibrinogen changes. *Am J Physiol* 220:218-221, 1971.
 27. Burnell RH, Maxwell GM: General and coronary haemodynamic effects of Tween 20. *Aust J Exp Biol Med Sci* 52:151-156, 1974.
 28. Sampson CB, Keeling DH: Adverse reactions to radiopharmaceuticals—a follow-up survey in the U.K. Report presented at the Annual Scientific Meeting, British Nuclear Medicine Society, London, 1982.
 29. Williams ES: Adverse reactions to radiopharmaceuticals: a preliminary survey in the United Kingdom. *Br J Radiol* 47:54-59, 1974.
 30. Ansell G, Tweedy MCK, West CR: Contrast media toxicology. *Br J Radiol* 57:548, 1984.
 31. Shehadi WH, Toniolo G: Adverse reactions to contrast media. *Radiology* 137:299-302, 1980.
 32. Stewart RB: Adverse drug reactions in hospitalized patients. *Pharm Int* 1:77-79, 1980.
 33. Miller RR, Greenblatt DJ (eds): *Drug Effects in Hospitalized Patients*. New York, John Wiley & Sons, 1976.
 34. Venning GR: Validity of anecdotal reports of suspected adverse drug reactions—the problem of false alarms. *Br Med J* 284:249-252, 1982.
 35. Kramer MS, Leventhal JM, Hutchinson TA, et al: An algorithm for the operational assessment of adverse drug reactions I. Background, description, and instructions for use. *JAMA* 242:623-632, 1979.
 36. Rhodes BA, Wagner HN Jr: Adverse reactions to radiopharmaceuticals. *J Nucl Med* 15:213-214, 1974.

21

Regulatory Problems in Nuclear Medicine

James F. Vandergrift

Governmental involvement in the practice of medicine has increased sharply within the past few years. The impact on health care has, for the most part, been in terms of financial interactions between health care facilities and federally funded health services programs. One might say that this type of governmental involvement has indirect impact on the medical and/or technical decisions in the practice of nuclear medicine. In other areas, however, governmental policies and regulations have had a more direct and fundamental impact on nuclear medicine than on any other medical specialty. Without an understanding and acceptance of this situation, the practice of nuclear medicine can be very frustrating. This chapter is thus written in the hope that potential frustration can be reduced or eliminated.

REGULATION VERSUS RECOMMENDATION

There are authorities at the federal, state, and local levels who set standards, write policies, and/or define responsibilities which may have the force of law (regulations) or may simply be "standards of good practice" (recommendations). Agencies that promulgate regulations are themselves given authority by, and limited to, specific legislation which defines their jurisdiction. Scientific and/or professional groups, although they may be highly respected and imminently qualified, provide only a consensus opinion in the form of recommendations. These recommendations may be accepted or rejected without specific penalty.

An example of the first category of authority is the Nuclear Regulatory Commission (NRC) and the second type is the National Council on Radiation Protection and Measurement

(NCRP). In practice, these agencies and their standards are not so well defined. The NRC is a regulatory agency but does, at times, issue guidelines and even voluntary standards. Also, the recommendations of the NCRP are, at times, issued by a regulatory agency as regulations, or they are made a part of regulations by specific reference.

As we proceed through this chapter, I do not attempt to distinguish between *regulation* and *recommendation*. This is relatively simple at the federal level, but there may be significant differences at state and local levels. In a specific nuclear medicine facility, one must first establish who is the most proximal authority and then ascertain what practices are a matter of regulatory compliance and what practices are a matter of practical circumstances and personal judgment.

SPECIFIC STAGES OF INTERACTIONS BETWEEN THE NUCLEAR MEDICINE FACILITY AND ITS REGULATORY AGENCIES

Licensing

Obtaining a nuclear medicine radioactive materials (RAM) license for a new facility or the renewal of a license for an established facility is a critical step in the regulatory process. The licensing process can be time consuming and tedious; therefore knowledge of the process is of help.

First, the type of license differs from one operation to another. For example, when only "exempt" quantities for in vitro procedures are to be used, one obtains a registration number by submitting a very simple application. At the other extreme, if one requires a broad scope

license to cover medical diagnosis, therapy, and research, the licensing process may be quite long and involved.

The licensing authority is either the NRC or a state agency. If the nuclear medicine facility is in a "nonagreement" state or is a federal facility (Veterans Administration hospital, military installation, etc.), the licensing authority is the NRC. In "agreement" states, the licensing authority often is a part of a state health depart-

ment but may be an autonomous agency or some other part of state government. In Table 21.1 are listed the agreement states and the licensing agency as of March 1984. The mailing address of the NRC for nonagreement states is included.

A first step in licensing is to contact the appropriate authority and obtain (a) a copy of applicable regulations, (b) a copy of that agency's "licensing guide," and (c) the forms

Table 21.1.
Addresses of Agreement State Licensing Agencies and the NRC

State	Agency	Address
Alabama	Division of Radiological Health	Environmental Health Administration Room 314 State Office Building Montgomery, Alabama 36130
Arizona	Arizona Radiation Regulatory Agency	Suite 2 925 South 52nd Street Tempe, Arizona 85281
Arkansas	Division of Environmental Health Protection	Arkansas Department of Health 4815 West Markham Street Little Rock, Arkansas 72205
California	Radiologic Health Section	Department of Health Room 498 714 P Street Sacramento, California 95814
Colorado	Radiation & Hazardous Waste Control Division Office of Health Protection	Department of Public Health 4210 East 11th Avenue Denver, Colorado 80220
Florida	Radiological Health Program Health Program Office	Department of Health and Rehabilitation Service 1323 Winewood Boulevard Tallahassee, Florida 32301
Georgia	Emergency Medicine and Radiological/Occupational Health Section	Department of Human Resources 47 Trinity Avenue Atlanta, Georgia 30334
Idaho	Radiation Control Section	Idaho Department of Health & Welfare State House Boise, Idaho 83720
Kansas	Bureau of Radiation Control Division of Environment	Department of Health and Environment Building 740 Forbes Field Topeka, Kansas 66620
Kentucky	Radiation Control Branch	Department of Human Resources 275 E. Main Street Frankfort, Kentucky 40601
Louisiana	Nuclear Energy Division	Office of Environmental Affairs P.O. Box 14690 Baton Rouge, Louisiana 70898
Maryland	Division of Radiation Control	Department of Health & Mental Hygiene 201 West Preston Street Baltimore, Maryland 20201
Mississippi	Division of Radiological Health	State Board of Health Jackson, Mississippi 39205

Table 21.1—continued

State	Agency	Address
Nebraska	Division of Radiological Health	State Department of Health 301 Centennial Mall South P.O. Box 95007 Lincoln, Nebraska 68509
Nevada	Radiological Health	Consumer Health Protection Services Room 103, Kinkead Building Capitol Complex Carson City, Nevada 89710
New Hampshire	Radiological Health Program Bureau of Environmental Health	Division of Health Services Health & Welfare Building Hazen Drive Concord, New Hampshire 03301
New Mexico	Radiation Protection Section	Environmental Improvement Division P.O. Box 968 Crown Building Sante Fe, New Mexico 87503
New York	Technical Development Programs	New York State Energy Office Agency Building 2 2 Rockefeller Plaza Albany, New York 12223
North Carolina	Radiation Protection Section	Division of Facility Service Box 12200 Raleigh, North Carolina 27605
North Dakota	Division of Environmental Engineering Radiological Health Program Radiation Control Service Division of Health	State Department of Health 1200 Missouri Avenue Bismarck, North Dakota 58501
Oregon	Department of Human Resources Division of Health	Department of Human Resources 1400 South West 5th Avenue Portland, Oregon 97201
Rhode Island	Division of Occupational Health	Rhode Island Department of Health Cannon Building 75 Davis Street Providence, Rhode Island
South Carolina	Bureau of Radiological Health	State Department of Health and Environmental Control J. Marion Sims Building 2600 Bull Street Columbia, South Carolina 29201
Tennessee	Division of Radiological Health	Department of Public Health Cordell Hull State Office Building Nashville, Tennessee 37219
Texas	Division of Occupational Health and Radiation Control	Texas Department of Health 1100 West 49th Street Austin, Texas 78756
Utah	Bureau of Radiation Control	State Department of Health 150 West North Temple Box 2500 Salt Lake City, Utah 84110
Washington	Radioactive Materials	Department of Social & Health Services Mail Stop LD-11 Olympia, Washington 98504
All Nonagreement States	United States Nuclear Regulatory Commission	Material Licensing Branch Division of Fuel Cycle & Material Safety Office of Nuclear Material Safety & Safeguards Washington, D.C. 20555

appropriate for the type of license being requested.

When making application, one should be aware that statements, procedures, records, etc. that are part of the application will, on approval, become part of the licensing document by reference. It is, therefore, important that the application represent honest intent and not an exercise in saying what "they" want to hear. Unrealistic or insincere statements at this time will almost certainly create problems at a later time.

The NRC and many agreement states have, in recent years, developed categories of use which help to simplify licensing applications somewhat.

One of the major components of an application is information regarding the physician's and/or user's qualifications. Specialty Board Certification is usually accepted as evidence of adequate training and experience. Certification in a professional specialty such as radiology or pathology, however, normally will not be considered adequate for all radiopharmaceutical procedures or for any therapy procedures. Certification by the American Board of Nuclear Medicine is generally accepted as adequate for all categories of routine diagnostic and therapeutic procedures involving radiopharmaceutical sources. This certification does not include teletherapy or brachytherapy with use of "sealed" sources, however.

License Amendments

The license, depending on how it is written, may not allow for innovations, new procedures, or even increased patient load. When this is the case and changes are desired, an amendment to the license is necessary. An amendment consists of a request to change a specific part or to add a new part along with justification in terms of safety and/or efficacy of the new procedure. When these changes involve experimental (non-routine) radiopharmaceuticals or an unapproved use of an established radiopharmaceutical, one must obtain Food and Drug Administration (FDA) approval or become accepted as an investigator under a manufacturer's Investigational New Drug (IND) submission. (Refer to Chapter 23 for detailed discussion of IND procedures.)

License Renewal

A license is issued for a specified period of time, usually 3 or 5 years. Three or 4 months prior to its expiration, renewal procedures should begin. If there are no changes to be made and a simple continuation of the present license is all that is needed, a request to extend the expiration date may suffice. Some agencies require that one "amend in entirety," however.

When an amendment in entirety is required, the amendment in effect consists of complete reapplication. In this case, the original application, with all changes and additions incorporated into a single up-to-date document, is submitted. Over a period of years, one may find it difficult to keep track of the separate amendments and the parts of the original license affected. An amendment in entirety can be very helpful in remedying this situation.

Radiopharmaceutical Purchases

Radiopharmaceutical suppliers are licensed and regulated in the same manner as are nuclear medicine facilities. One of the requirements is that suppliers do not transfer (sell) any radioactive material to anyone unless the recipient is authorized to receive the specific material requested. Radiopharmaceutical suppliers, therefore, will require that each facility provide documentation as proof of authorization. A copy of the license or other documentation should show the expiration date, radionuclides, chemical forms, maximum possession limits and, in many cases, the patient dosage range and clinical usage. Supplier records should be updated each time the license is amended and renewed if there are changes affecting any of these data.

On-site Inspections

The licensing agency normally conducts on-site inspections to assure that (a) general regulatory safety standards, (b) specific licensing conditions, and (c) record-keeping practices comply with the regulations. Inspection frequency varies from state to state. Facilities licensed by agreement states tend to be inspected more frequently than are facilities licensed by the NRC. In both cases, inspections can be either announced or unannounced.

Radioactive material license inspections, like most inspections, tend to rely heavily on records

as the primary evidence of compliance. Surveys, interviews, and measurements by inspectors are not uncommon, however.

There is one source of encouragement relative to these inspections. The RAM license inspection is so thorough and comprehensive that inspections by other agencies often consist of a simple review of the findings of the RAM license inspection. For example, hospitals are inspected by the Joint Commission on Accreditation of Hospitals (JCAH) as well as other licensing and/or accreditation agencies. When these inspections occur, JCAH inspectors very often simply ask to see the report of the last RAM license inspection.

Of course, the first priority of the JCAH is to assure that their standards for quality of patient care are met, whereas the first priority of the NRC (or agreement state agency) is to assure safe use of radioactive materials. Because of this difference in priorities, the two inspections may not be identical.

The following list contains items commonly reviewed during RAM license inspections:

1. Inventory. Are the amount and the type of material in agreement with those indicated in the license? Are records of receipt, use, and disposal complete and up to date?
2. Survey and monitoring records. Are surveys conducted as required, and are they recorded properly? Are high exposure and/or contamination levels investigated, and is corrective action taken? If an ALARA (as low as reasonably achievable) program is required, what studies, results, and conclusions are available as evidence that doses are as low as reasonably achievable?
3. Instrument calibration. Are clinical and safety instruments checked on a regular schedule for reproducibility, linearity, and/or accuracy?
4. Quality assurance. What are the tests and results of tests for radiopharmaceutical quality? What tests are performed and what are the results with regard to image quality and/or the diagnostic quality of patient data?

Low-level Radioactive Waste (LLW) Disposal

Radioactive waste disposal has always been a problem in nuclear medicine, but because of the

enormous increases in cost over the past few years and more strict requirements on generators in gaining access to commercial disposal sites, this aspect of nuclear medicine is becoming a more significant problem. The relatively short half-life of most radiopharmaceuticals in clinical use is the only reason that this problem has been kept from becoming insurmountable.

Only five options are available for LLW disposal. In Table 21.2 are listed the methods of LLW disposal, the relative cost of LLW disposal, and the major limitations imposed by each use.

Within the clinical nuclear medicine facility (disregarding vendors), LLW disposal very often can be handled by a combination of (a) returning expired or used sources to the supplier or (b) radioactive decay and disposal of "cold" residue.

The radiopharmaceutical aspects of nuclear medicine consist of an "in-house" operation or an outside supplier who provides radiopharmaceuticals in "unit dose" quantities on a daily basis, and this will directly impact on LLW disposal.

In-house Radiopharmacy: LLW Disposal Aspects

For the in-house radiopharmacy, the following steps are of help in the management of LLW disposal:

1. Include return and disposal of nuclide generators as part of the purchasing agreement.
2. Avoid practices that produce a large volume of waste.
3. Segregate waste according to half-life, i.e., $t_{1/2} < 24$ hours, 24 hours $< t_{1/2} < 1$ week, etc.
4. Compact dry waste to reduce volume.
5. Set up practices to label, store, and discard "decayed" waste.

Unit Dose Radiopharmaceutical Supplier: LLW Disposal Aspects

For those facilities with a unit dose radiopharmaceutical supplier, the following steps are of help in the management of LLW disposal:

1. Include return and disposal of LLW as part of purchasing contract.

Table 21.2.
Comparison of Methods for Low-level Radioactive Waste Disposal

Disposal Method	Relative Cost	Limitations
Sewage system disposal	Very low	<ol style="list-style-type: none"> 1. Very difficult to control and document compliance 2. Gross limit is 1 Ci/yr/facility
Incinerator	Low to moderate, depending on availability of existing facility and physical control requirements	<ol style="list-style-type: none"> 1. Very difficult to prove compliance with stack concentration requirements, and this is compounded when a mixture of nuclides is involved 2. May produce radioactive ash requiring secondary disposal methods 3. Specific licensing approval is required
Storage decay	Moderately expensive because a secured space is required and, special shielding may be required	<ol style="list-style-type: none"> 1. Space requirements for long-term storage may be prohibitive 2. Requires careful segregation of waste at the time of generation 3. Means and methods for assaying waste or sufficient records to assure "complete" decay
Venting to atmosphere	Cost will depend on the means available plus provision for an isolated ventilation system	<ol style="list-style-type: none"> 1. Waste must be in gaseous or volatile form 2. Strict limitations on concentration at point of release
Burial (landfill)	Very low cost	<ol style="list-style-type: none"> 1. In many jurisdictions this is prohibited 2. May result in legal problems at a later time 3. May require specific licensed authorization
Burial (commercial)	Most expensive method	<ol style="list-style-type: none"> 1. Cost 2. Access to disposal site is difficult at present and, depending on present efforts to establish "regional compacts," may become more difficult

2. Steps 2, 3, 4, and 5 above apply, but the problem of volume reduction is much less significant, since vials, syringes, etc. are returned for disposal and gloves, cotton swabs, etc. should be the only remaining source of LLW. Paper towels, plastic bags, etc. may, of course, become contaminated from accidental spills and resulting decontamination.

FEDERAL, STATE, AND LOCAL REGULATORY AGENCIES

The difference and the relationship between regulatory agencies at different levels of government as well as the relationship between different agencies at the same governmental level are

impossible to define in a general or comprehensive way. Regulations at the federal level are generally applicable to all subdivisions, but state or local regulations can be more strict or cover sources of radiation not included in federal regulations.

The NRC is authorized to regulate the purchase, receipt, use, and disposal of by-product materials used in nuclear medicine. This authority does not include regulation of other radionuclide sources, such as accelerator-produced or naturally occurring sources. All radiopharmaceuticals, however, are regulated by the FDA. The FDA is authorized to regulate the entire process, from radiopharmaceutical research and development to marketing, distribution, and clinical use. Therefore, any radioactive material

used for medical purposes is subject to controls by one or both of these agencies.

Figure 21.1 provides a simplified description of the relationships between a nuclear medicine operation and the various federal and state regulatory agencies. As is indicated, the NRC and the state licensing agency have fundamental and general authority, whereas the FDA, Environmental Protection Agency (EPA), Department of Transportation (DOT), and Occupational Safety and Health Administration (OSHA) have authority over limited aspects of operation. All of these agencies have responsibilities beyond those relating to nuclear medicine.

The EPA, for example, is generally responsible for establishing and enforcing standards to protect people and the environment from the disposal and/or release of all hazardous materials. The disposal of radioactive materials is only a small part of this responsibility. Likewise, the NRC is responsible for regulation of industrial use of by-product materials as well as fissionable materials used in electrical power generation.

LIMITS IMPOSED ON CLINICAL PRACTICE AS A RESULT OF REGULATIONS

With respect to the physician, a license to practice medicine which authorizes the holder to prescribe and administer "prescription" drugs does not authorize the physician to pre-

scribe or administer radiopharmaceuticals. This authority is granted only by the NRC or the appropriate agency of an "agreement state." Furthermore, a RAM license issued to a medical facility or physician is limited to the physician(s) specifically stated in the license and the clinical procedures covered by a license are to be carried out by these individuals or under their direct supervision.

As stated earlier, there are training and experience requirements for licensure in nuclear medicine beyond the "normal" medical training. Also, a physician may meet the requirements for group I procedures involving uptake or dilution studies and not meet requirements for group III procedures involving the use of generators and reagent kits (1). In almost all states, the restrictions on the medical use of ionizing radiation from radioactive materials does not restrict the medical use of ionizing radiation from x-ray generators.

SPECIAL COMPLIANCE PROBLEMS IN NUCLEAR MEDICINE

Radioactive Patient

The patient in nuclear medicine is listed as a special compliance problem because (a) the regulations that can be applied (radiation dose levels, release of radioactive materials, etc.) do not specifically address the patient and (b) the standards that are available are not published by

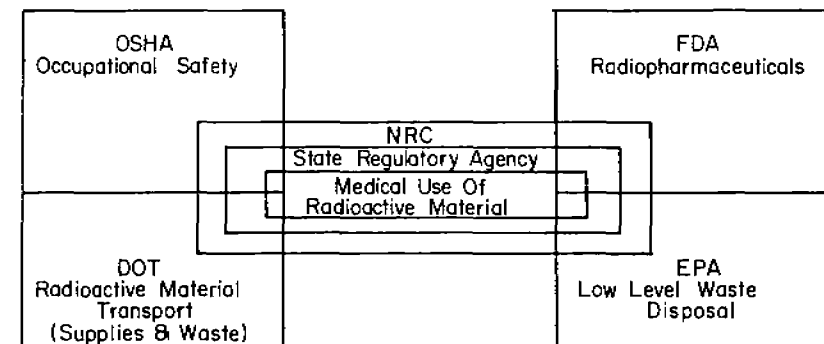

Figure 21.1. Diagram showing the relationship between a nuclear medicine facility and various regulatory agencies.

a regulatory agency and do not apply mainly to hospitalized patients.

An exemption is generally assumed with respect to monitoring, permissible concentrations and body burdens, sewage waste disposal, etc. for radioactivity administered to a human being for diagnostic purposes. Therapeutic levels of radioactivity are only slightly more regulated. Currently, the NRC generally requires (as a license "condition," not by regulation) that a patient be hospitalized if he receives more than 30 mCi of a radionuclide and that he not be released until the radionuclide burden falls below 30 mCi. A revision of part 35 of Title 10, Code of Federal Regulations (10 CFR 35), which may officially change, among other things, the criteria used to determine when a patient can be released following therapy with radiopharmaceuticals, is being considered. Although not yet finalized (as of May 1986), the revised document will likely state that a patient cannot be released from the hospital until the exposure rate from the patient is <6 mR/hr at a distance of 1 m. In contrast, the NCRP recommends that a patient be hospitalized if the initial activity exceeds a certain specified level, depending on the radionuclide involved and the age of household members who will be in contact with the treated individual. In Table 21.3, the more common therapy sources and their minimum "outpatient" levels as given in NCRP

Report No. 37 (2) are listed. Very often a "condition" stating how to handle radioactive patients will be a part of the RAM license if therapeutic procedures are permitted by the license.

In addition to, or as a part of, a licensing "condition," specific provisions and instructions must be developed for members of the hospital staff outside the nuclear medicine service. Addressed in these instructions should be:

1. Patient room assignment policies.
2. Instructions to nursing care personnel.
3. Instructions regarding dietary services and contaminated food dishes and utensils.
4. Instructions regarding potentially contaminated waste, linens, and furnishings for housekeeping and laundry services.
5. Instructions for clinical laboratory services and personnel.
6. Policies regarding surveys and room reassignment following patient discharge.
7. Instructions regarding child care, pregnant family members, food handling, etc. for the patient and the patient's family.
8. Provisions and instructions must also be provided in the event of death of the patient during a specified period following a therapeutic administration. These policies should be addressed to the pathologist and funeral service personnel.

Table 21.3.
Radioactivity Levels for Discharge of Radioactive Patients from Hospital*

Radionuclide	No Restrictions	Some Restrictions Required	
		All Household Members >45 YOA†	Some Household Members <45 YOA†
⁵¹ Cr	35 mCi	350 mCi	100 mCi
¹⁹⁸ Au	23 mCi	230 mCi	70 mCi
¹²⁵ I	0.2 mR/hr at 1 m	2 mR/hr at 1 m	0.5 mR/hr at 1 m
¹³¹ I	8 mCi	80 mCi	50 mCi
¹⁹² Ir	0.4 mCi	4 mCi	1.2 mCi
²²² Rn	4.6 mCi	46 mCi	18 mCi

* Adapted from Table 4, NCRP Report No. 37, National Council on Radiation Protection and Measurements, 1970 (2).

† YOA, years of age.

Control of Radioactive Gases

The containment, detection, control, and disposal of radioactive solids and liquids are technically simple, compared with those of radioactive gases. When radioactive gases such as ¹³³Xe are used, special attention must be given for their licensing, use, and disposal.

Ventilation systems that meet requirements for temperature and comfort control may not be adequate in terms of flow rate and the relative supply and/or exhaust rates within an imaging room.

Licensing of radiogases requires that the air flow rate be adequate to dilute the gas released into the room below the permissible concentration (1×10^{-5} μ Ci/m³) averaged over a year. In addition to average dilution volumes, the exhaust rate should exceed the supply air rate so that air movement is always into the contaminated air. In other words, a room in which ¹³³Xe is handled should be at "negative pressure."

Accidental "spills" of radioactive gases and associated procedures also must be addressed. Unlike liquid spills, the only appropriate action for gas release is to evacuate the area and allow sufficient time to pass for dilution and/or removal to occur. The time required for exchange of 10 room volumes of air is an accepted "rule of thumb."

Ventilation system isolation is a basic requirement for meeting the flow rate specifications in each of these situations.

ALARA

The ALARA concept is as old as nuclear medicine; within recent years, however, it has taken on a more formalized, systematic, and regulatory meaning. The NRC Regulatory Guide 10.8 includes Appendix O, "Model Program for Maintaining Occupational Radiation Exposures at Medical Institutions ALARA" (3). The title and source of this publication imply that (a) it is subject to alterations and modification and (b) it specifically applies to NRC licenses.

At the present time, the major impact of ALARA is on occupational radiation exposure as demonstrated by "whole body" monitoring (dosimeter records). Maximum permissible

dose (MPD) limits have not been changed. What has changed is the dose level at which investigation and corrective actions are initiated. This change (as stated in Regulatory Guide 10.8) requires that any occupational radiation dose above the MPD for the occasionally exposed worker (i.e., 10% of MPD for the occupationally exposed worker) must be investigated by the Radiation Safety Officer (RSO) and reviewed by the institutional Radiation Safety Committee (RSC). When occupational doses exceed 30% of MPD, corrective actions are required or the institution must specifically justify a higher dose level.

As stated earlier, ALARA policies do not lower MPD, nor do they seem to imply that these dose levels are unsafe.

There is a noteworthy inconsistency between this ALARA policy statement and the regulation requiring personnel monitoring. Investigational level I is 10% of the occupational MPD. The level of occupational exposure which requires that a dosimeter be issued is 25% of the applicable MPD. An attempt to change the regulation to set the dosimeter requirement at 10% MPD is being made, however. At the present time, this ALARA policy can only be achieved if each employee's likelihood of receiving a quarterly dose of 125 mrem to the total body is reevaluated. A reevaluation of hospital operations is likely to result in an increase in the number of people monitored if the 10% level instead of the traditional 25% level is used. The investigation, tabulation, and explanation of personnel doses above 10% by the RSO will certainly increase the time, effort, and cost required. In the past, many institutions have used a 75% "action level" for investigating individual exposures.

SUMMARY

Compliance with government regulations is as much a part of the practice of nuclear medicine as is equipment purchasing, technical procedures, patient selection, or any other part of the total operation. Unfortunately, it is viewed by many as the most undesirable, unpleasant, and unproductive aspect of this medical specialty. An objective analysis, however, will show that the vast majority of regulatory re-

quirements are necessary in order that employee, patient, and community safety not be jeopardized or ignored. It is in the interest of every person not only that we tolerate regulation but also that we become actively involved with the development, implementation, evaluation, and modification of these regulations. Only in this way can safety be maintained, cost be controlled, and the community's medical needs be met.

REFERENCES

1. Title 10, Code of Federal Regulations, Part 35: Human uses of by-product material. United States Nuclear Regulatory Commission.
2. National Council on Radiation Protection and Measurements, Report No 37: *Precautions in the Management of Patients Who Have Received Therapeutic Amounts of Radionuclides*. NCRP Publications, October 1970.
3. United States Nuclear Regulatory Commission, Office of Standards Development, Regulatory Guide 10.8: *Guide for the Preparation of Applications for Medical Programs*. October 1980.

III

Considerations for the Preclinical and the Clinical Investigation of New Radiopharmaceuticals

Animal Models of Human Disease

Prantika Som and Zvi H. Oster

WHAT IS AN ANIMAL MODEL?

A model, as defined in the Oxford English Dictionary, is "something that accurately resembles something else." No dictionary describes an animal model or animal model of disease. Wessler (1) has defined animal model of disease as "a living organism with an inherited, naturally acquired or induced pathological process that in one or more respects closely resembles the same phenomenon occurring in [the] human." No single animal model can ever duplicate a human disease; it can provide only similarity to the disease process. The term "model" implies an identical replica of the disease in humans, which never happens. For lack of a better word, it is used commonly in reference to the similar pathophysiological occurrence in humans. For a model to be useful it does not necessarily have to be identical to the human conditions (2). Sometimes, mice are better models for some human diseases than are primates. Moreover, cost and availability allow many more mice to be tested. Animals that are phylogenetically closer to humans (viz., non-human primates) are often, however, better indicators of human pathophysiology.

The evaluation of radiopharmaceuticals in animal models prior to their use in humans is well established and required by law. This evaluation serves several purposes: to investigate the kinetics and localization of the compounds, to determine toxicity, and to calculate the radiation dose. Most studies are performed on animals in a normal physiological state, while some studies must be performed in conditions simulating human pathophysiology. Although at the present time no animal model mimics exactly the

normal human physiological state and reproduction of human disease entities in animals is even harder to obtain, the data acquired from animal models have been of great help in understanding normal and pathological conditions as well as developing diagnostic and therapeutic agents for use in humans.

The selection of an animal model for a specific study is most important in order to assure that the outcome of the study is not compromised. One must consider not only the appropriateness of the model but also the availability, the ease of handling and disposal, and the cost of the animal.

Furthermore, in working with radiolabeled compounds, the amount and specific activity needed to obtain adequate counting statistics should be balanced with the need to minimize radiation exposure to personnel.

Extrapolation of data from animal experiments to humans must take into account the differences in overall size, differences in relative organ size, differences in life-span, species variations in protein and enzyme patterns and the metabolic rate, and variations in the number of functional cells per gram of tissue.

Moreover, the clinical expression of an etiological agent may differ in humans and animals, although various etiological agents may produce similar clinical expressions. Nonetheless, the growing awareness of the important contributions that animal models can make to the advancement of medical science has led to the discovery of many animal models that can serve as replicas of human disease. It is impossible to list all the models available; therefore, we discuss the most commonly used models in nuclear medicine science and the need and possibilities

of using some newer models. The Registry of Comparative Pathology of the Armed Forces Institute of Pathology has published a handbook that describes 150 models of animal disease relevant to the study of human disease and that is mainly based on comparative pathology (3).

SKELETAL SYSTEM

The pathophysiology of the skeletal system not only involves its static supportive function but also affects the dynamic (metabolic and homeostatic) functions. Bone serves not only as a mineral reservoir but also as the primary site of hematopoiesis. Since ancient time the skeletal disorder and the process of fracture healing have been of interest to mankind. Almost every mammalian species (bats to primates) has been used as animal models for bone metabolism. Rodents (smaller animals) are cheap to buy, and therefore, more extensive studies can be carried out with use of rodents than, for example, with use of primates. The skeleton of small animals such as rodents responds differently to alterations in hormone, vitamin, and mineral levels, and therefore, use of these animals presents a problem. Homeostatic regulation of vitamin D levels is known to occur in various laboratory animals and in rats; parathyroid hormone has a different end-organ effect on animals than on humans. Moreover, rat and mouse bone lack an Haversian system, and therefore, rats and mice demonstrate continued epiphyseal growth for their entire life-span. The bone structure in non-human primates is similar to the bone structure in humans and responds to hormones, vitamins, and minerals in an identical manner. Horses also show such similarities. Nevertheless, large animals such as monkeys and horses are very seldom used as disease models primarily because of their high cost. Many small animal models have been studied to measure the blood flow in normal bone (4–11). The animal models of disease most frequently studied include those associated with fracture, inflammatory lesions, and metabolic disorders. There is no ideal animal model to study the metabolic derangements of bone, primarily because bone metabolism is a complex phenomenon involving the interaction of vitamins, minerals, and hormones, which are

still very poorly understood in human bone metabolism. Osteoporosis, the most common metabolic disorder in humans, is brought about by various types of immobilization. These include neurogenic immobilization, immobilization following fractures, rheumatoid arthritis, trauma, and bed rest. Several animal models of immobilization osteoporosis are available. In Table 22.1 are summarized the commonly used animal models of bone disease and appropriate references (12–31).

CARDIOVASCULAR SYSTEM

Animal models of myocardial infarction (MI) have been used extensively for the study of the hemodynamic, metabolic, histologic, and electrocardiographic deviations from the norm as well as for the study of the acute and late sequelae of MI. Five animal models have evolved: rats, rabbits, dogs, pigs, and primates. In the rat, focal myocardial necrosis, but not true myocardial infarction, has been produced by the injection of epinephrine (32) or of isoproterenol (33) or by electrical burns over the epicardial surface (34, 35). Some of these models served for the evaluation of infarct-avid imaging agents (34, 35). The advantages of the rat model are (a) availability at low cost and (b) ease of handling; therefore, it is possible to perform studies on a large number of animals. Because of the rat's small size, however, this model does not allow for imaging with the gamma camera. In a slightly larger animal, e.g., the rabbit, local myocardial necrosis can be produced by intracardiac injection of vasopressin in oil (36).

In the dog, myocardial infarction can be produced by permanent or temporary ligation of a coronary artery (37–39). The study of collateral development after coronary occlusion was studied with the ^{133}Xe washout method (40), and the early metabolic changes after coronary occlusion, including ^{99m}Tc -pyrophosphate accumulation, could also be observed (41). Since open-chest models in the anesthetized dog are not comparable to MI in the human, variations of the technique have been developed in the intact conscious dog. The transcatheter placement of clips on the coronaries (42) is one such example of permanent coronary artery constriction. Al-

Table 22.1.
Animal Models of Bone Disease

Disease	Animal	Reference
Blood flow:		
Femoral head viability	Dogs	12
Fracture:		
Healing process, osteogenesis	Rabbits, Dogs	13–15
Osteomyelitis:		
Pathologic and radiographic appearance similar to human	Rabbits, Dogs	14, 16
Arthritis:		
Degenerative, similar to human osteoarthritis	Rabbits	17
Polyarthritis, acute self-limiting	Rats	18, 19
Metabolic bone disease:		
Rickets	Rats	20
Hypervitaminosis A, cessation of bone formation, destruction of cartilage	Rats	14
Osteoporosis:		
Immobilization (local disuse)	Rabbits, Dogs, Rats	21–24
Immobilization (systemic, whole body)	Monkeys	25–27
Ammonium chloride induced: similar to calcium deficiency osteoporosis	Rats	28
Low-calcium diet	Rats	29–30
Osteomalacia	Young rats	31

ternatively, devices that constrict a coronary artery can be placed surgically, and the device may be activated to constrict the artery after the recovery of the animal (43, 44). A simpler method is the transcatheter insertion of plugs that expand on contact with blood (45, 46) or the transcatheter introduction of a copper coil around which thrombus forms rapidly (47). Situations that simulate strenuous exercise have been described also (48).

Although the dog is a very convenient model for study of the function of the human heart, two differences distinguish the function of the heart of a dog from that of a human. The dog has a predominantly left coronary circulation, whereas the human has a predominantly right coronary circulation, and the dog develops profuse collaterals in response to coronary artery occlusion. Primates which have a coronary circulation and physiology similar to that in humans have been used for the study of the heart (49, 50), although their widespread use has been restricted by high cost and by handling difficulties. The coronary circulation in swine is very similar to that in humans, and although swine are available and not very expensive, they are harder to manage, and there are difficulties

with anesthesia and arrhythmias (51–53).

A basic deficiency of these previously mentioned models is that only one vessel in these animals is affected by the intervention, whereas many vessels in the human suffering from MI may be affected. Atherosclerosis can be induced in animals by various interventions of long duration. Repeated intravenous adrenalin injections and a milk and egg diet were reported to induce atherosclerosis in rabbits (54, 55); overdosage of vitamin D induced calcinosis of the major arteries (56); and various combinations of high-cholesterol, high-fat diets with or without thiouracyl were found to induce atherosclerosis in the rat (57), rabbit (58), swine (59), and rhesus monkey (60).

Hypertension has been studied with the Goldblatt model (61), bilateral nephrectomy, and dialysis in the dog (62); with unilateral nephrectomy, high-salt diet, and desoxycorticosterone in the rat (63); and with cellophane wrapping for compression of one kidney in the mouse, rat, rabbit, and dog (64, 65). The breeding of salt-dependent hypertensive rats enables the study of genetically identical animals with and without hypertension (66).

A dog model of hemorrhagic (67) and car-

diogenic shock (68) has been described also. Myocarditis can be induced in the rat (69) and rabbit (70) by epinephrine; endocarditis has been induced by mechanical damage and bacterial inoculation (71-73). In the dog, spontaneous chronic valvular fibrosis occurs with high frequency (74). Uremic pericarditis caused by bilateral ligation of the ureters in the rabbit (75) and cobalt-induced cardiomyopathy in the guinea pig have been reported (76). In Table 22.2 are listed the commonly used animal models of cardiovascular disease (32-76).

CENTRAL NERVOUS SYSTEM

Many animal species, particularly rats, cats, and nonhuman primates, have been used to study neurophysiology as well as neuropathology. A select few are discussed here. In a recent report, the neurological diseases of animals were discussed in relation to those in humans (77). Some models are close replicas of human pathology, others merely mimic certain pathologic processes, while others are quite variable. The more prevalent diseases of the human nervous system are less well represented by good animal models. There is no other good model of stroke due to cerebral infarction than that of old pigs (78). Due to the natural susceptibility of their cerebral vasculature to atherosclerosis, however, pigs are more commonly used to study vascular disorders (79-81). At 10-12 years of age, pigs develop spontaneous atheromatous plaques of significant severity and frequency on the intracranial portions of the internal carotid arteries, basilar artery, and middle and anterior cerebral arteries, a pattern similar to that which occurs in humans. Pigs, more than any other mammals, are also susceptible to various infections of the nervous system. Recently, a stroke-prone hypertensive rat strain has been developed which appears to be a useful model for studying strokes resulting from hypertensive cardiovascular disease in humans (82). Several demyelinating disorders similar to multiple sclerosis have been studied in animals; none, however, are a counterpart of multiple sclerosis in humans (83, 84). An animal model of amyotrophic lateral sclerosis has not yet been reported. Down's syndrome has been observed as a natural phenomenon in aging mice and in

nonhuman primates (85, 86). Down's syndrome in humans is associated with Alzheimer's disease. Although senile plaques that are associated with Alzheimer's disease have been reported in aged dogs and monkeys (87-89), they lack the twisted neurotubules invariably present in human lesions. Many of the microscopic changes characteristic of the aged human brain are also seen in the brain of old animals, but they are less extensive than those in humans (90). Alzheimer's disease is the most common degenerative disease of the human nervous system, and there is a lack of an appropriate animal model with similar clinicopathologic manifestations. Although many neurophysiological models have been studied in animals, models of human disease are not as varied. Aseptic and septic meningitis and the clearance of chelates have been studied in the dog (91, 92). Encephalitis can be produced in hamsters by inoculation of the Edmonston strain of measles virus (93), and hydrocephalus can be induced in the dog by the injection of Silastic into the basal cisterns (94). Hydrocephalus can also be induced in smaller animals. The administration of 6-aminonicotinamide to pregnant rats results in hydrocephalus in the offspring (95), and vitamin A deficiency in the pregnant rabbit results in congenital hydrocephalus in 70% of the offspring (96). Cerebral microembolisms induced by the injection of carbon microspheres in the rat have been studied with use of multiple tracers (97), and a model of subdural hematoma can be produced in dogs by injection of a mixture of autologous blood and cerebrospinal fluid (98). In conscious squirrel monkeys, epilepsy of short duration can be induced by cobalt powder (99). The study of central nervous system (CNS) tumors in large animals has been limited to spontaneously occurring cases, and most studies in which transplantable tumors were used were conducted in small rodents (100, 101). Animal models of induced diseases of the CNS are shown in Table 22.3 (91-101).

RESPIRATORY SYSTEM

For extrapolation of data from animal models of lung pathology to human diseases, consideration should be given to anatomical (102, 103) and functional differences between species

Table 22.2.
Animal Models of Cardiovascular Disease

Disease	Animal	Reference
Myocardial necrosis:		
Epinephrine	Rats	32
Isoproterenol	Rats	33
Electrical burns	Rats	34, 35
Vasopressin, intracardiac	Rabbits	36
Myocardial infarction:		
Permanent or temporary ligation of coronary artery	Dogs	37-39
Study of collateral development, ¹³³ Xe	Dogs	40
Early metabolic changes, PYP accumulation	Dogs	41
Transcatheter clip placement	Dogs	42
Perivascular balloon snare	Dogs	43, 44
Expanding sponge plug	Dogs	45, 46
Copper coil inducing thrombus formation	Dogs	47
Exercise model	Dogs	48
	Baboons and rhesus monkeys	49, 50
	Pigs	51-53
Atherosclerosis:		
Repeat intravenous adrenalin	Rabbits	54
Milk and egg diet	Rabbits	55
Vitamin D overdosage, calcinosis	Rats	56
Thiourea, cholic acid, cholesterol and fat	Rats	57
Intermittent cholesterol feeding of mature animals	Rabbits	58
High-fat and high-cholesterol diet plus propylthiouracyl and irradiation	Swine	59
Five different diets	Rhesus monkeys	60
Hypertension:		
Goldblatt kidney	Dogs	61
Bilateral nephrectomy plus dialysis	Dogs	62
Unilateral nephrectomy plus DOC plus NaCl	Rats	63
Unilateral cellophane wrapping	Rats	64
Figure-of-eight ligation of one kidney	Mice, rats, rabbits, and dogs	65
Dahl salt-dependent hypertensive rats	Rats	66
Shock:		
Hemorrhagic	Dogs	67
Cardiogenic	Dogs	68
Myocarditis:		
Epinephrine induced	Rats	69
	Rabbits	70
Endocarditis, arteritis, valvular damage:		
Mechanical damage	Rabbits	71
Puncture of aortic valve plus enterococci	Dogs	72
Placement of catheter plus staphylococcus	Rabbits	73
Spontaneous chronic valvular fibrosis	Dogs	74
Pericarditis:		
Bilateral ligation of ureters, uremia	Rabbits	75
Myocardiopathy:		
Chronic cobalt feeding	Guinea pigs	76

(104, 105). Despite the inherent drawbacks, much has been learned from animal models about mechanisms of human diseases of the

respiratory system and about therapeutic modalities.

The study of pulmonary emboli in the dog

Table 22.3.
Animal Models of Induced Diseases of CNS

Disease Characteristics	Animal Model	Reference
Aseptic and septic meningitis	Dogs	91, 92
Encephalitis, viral	Hamsters	93
Communicating hydrocephalus:		
Silastic injection in basal cisterns	Dogs	94
6-Aminonicotinamide to mothers	Rats	95
Vitamin A deficiency in pregnant animals	Rabbits	96
Cerebral microembolism:		
Carbon particles	Dogs	97
Chronic subdural hematoma:		
Injection of autologous blood plus CSF	Dogs	98
Epilepsy induced by cobalt powder	Monkeys	99
Brain tumors:		
Intravenous methyl nitrosourea	Rats	100
Implanted intracerebrally	Mice	101

and the uptake of labeled streptokinase (106), the effect of clot age on the fibrinogen uptake (107), and the accumulation of platelets on denuded endothelial sites (108) are well documented. A model of pulmonary hypertension can be produced in the rat by hypoxia (109) or *Crotalaria spectabilis* feeding (110). Hyaline membrane disease of the lung has been studied in foals and piglets in which it occurs spontaneously (111) or in premature rhesus monkeys exposed to high oxygen levels (112). Lung carcinoma models in mice, rats, and hamsters have been studied intensively (113), but experimental studies in larger animals have been conducted only on spontaneously occurring cancers of the lung.

Only certain dogs are suitable as models of an extrinsic IgE-mediated or an intrinsic type of asthma (114). Studies on bronchoconstriction in guinea pigs (115) as well as in other animals with asthmatic conditions have been carried out, however (116). Chronic bronchitis in the rat occurs spontaneously and mostly is due to *Mycoplasma pulmonis* infection. Its outstanding features include, however, inflammatory changes in the parenchyma which result in bronchiectasis (117). Some breeds of small dogs are more suitable models of human chronic bronchitis which is characterized by increased mucous secretion (118).

Idiopathic pulmonary fibrosis occurs spontaneously in cattle (119), and experimental em-

physema models have resulted from bronchial instillation of elastase in sheep (120) or papain in dogs (121). The sheep model is worth mentioning because it permits simultaneous measurements of various parameters. Animal models of lung disease are listed in Table 22.4 (106-123).

GASTROINTESTINAL SYSTEM AND PANCREAS

Digestive System

The criteria for a suitable animal model for gastrointestinal tract disease are: (a) a host whose gastrointestinal tract resembles that of the human in structure and function, (b) the disease that closely mimics the human condition, and (c) the availability of either large numbers of animals with spontaneous disease or reproducible experimental models (124). Dogs (and to a lesser extent cats) have been extensively studied to understand the inflammatory neoplastic and inherited abnormalities that afflict the alimentary tract of humans.

The major human digestive tract diseases for which an appropriate animal model is important are: peptic ulcer, ulcerative colitis, Reye's syndrome, cirrhosis, hepatitis, gallstones, biliary atresia, and Crohn's disease. Dogs have been used for most of the studies on pancreatitis. Pancreatitis, acinar cell carcinoma (125), and juvenile atrophy (126) are exocrine pancreatic

Table 22.4.
Animal Models of Lung Disease

Model	Animal	Reference
Pulmonary embolus:		
Thrombin injected into vein segment, clot released	Dogs	106
Venous thrombus:		
Electrical stimulation	Dogs	107
Pulmonary hypertension:		
Hypoxia	Rats	109
<i>Crotalaria spectabilis</i>	Rats	110
Hyaline membrane disease:		
Spontaneous	Foals, piglets	111
O ₂ induced	Rhesus monkeys	112
Carcinoma of lung:		
Intrabronchial polycyclic hydrocarbons	Rats, mice, hamsters	113
Asthma:		
Spontaneous	Dogs	114
Bronchoconstriction	Guinea pigs	115
Acute respiratory distress syndrome: phorbol myristate acetate (PMA)	Rabbits	122
Chronic bronchitis:		
<i>Mycoplasma pulmonis</i>	Mice	117
Spontaneous	Dogs	118
Idiopathic pulmonary fibrosis:	Cattle	119
Emphysema:		
Elastase	Sheep	120
Papain	Dogs	121
Pulmonary fibrosis	Mice	123
Review of animal models of respiratory diseases	Various	116

diseases that occur in the dog and have potential as models. If a canine model is used, one should be aware that the canine small intestine is an active amylase-secreting organ and that the canine liver degrades amylase more slowly than does the human liver; as a result, normal serum amylase levels are higher in dogs than in humans. A monograph on experimental acute pancreatitis discusses comparative studies and the applications of experimental results to conditions in humans and emphasizes that the different enzyme patterns in related species and species-specific anatomical features are important (127).

Rodent models have also been used frequently for the study of pancreatitis. It has been suggested that infectious pancreatitis resulting from use of coxsackievirus B1 in mice provides a good model for studying pancreatic disease due to viruses and for elucidating the relationship between diabetes mellitus in humans and viral infection with coxsackievirus B and other

viruses (128). A comparison of alcoholic pancreatitis in humans and rats has shown that the rodent model exhibits similar histological changes (129). Animal models of gastrointestinal tract diseases are listed and referenced in Table 22.5 (130-141).

Hepatobiliary System

Many models of normal animals have been used for evaluation of hepatobiliary radiopharmaceuticals (142-146). Observations made in animals cannot always be translated to humans. Certain general ideas on the uptake, storage, and clearance of a radiopharmaceutical, however, can be obtained, and the effects of pharmacological and physical interventions can be observed. There are significant interspecies differences in both hepatic anatomy and physiology as well as in the hepatic and biliary storage and excretion capacity of various substances (147-151). Bromosulphophthalein (BSP) has been widely used to study hepatic physiopa-

Table 22.5.
Animal Models of Gastrointestinal Tract Diseases

Disease	Animals	Reference
Esophagitis:		
Acid-pepsin induced	Cats	130
Chronic duodenal or gastric ulcers:		
Acetic acid induced, resembles human peptic ulcer	Rats, cats	131, 132
Catecholamine induced		133
Iodoacetamide-induced ulcer of glandular stomach, with many features similar to human disease		134
Propionitrile or cysteamine induced, with morphological aspects similar to human disease	Rats	135, 136
Gastrointestinal bleeding	Dogs	137-139
Gastroenteritis:		
Virus induced, model of acute infantile diarrhea	Pigs	140
Intestinal blood flow	Dogs	141

thology. The hepatic storage capacity of BSP and its biliary transport have been quantified in several animal species with normal as well as abnormal hepatic function. Both spontaneous bile flow and biliary transport maximum (Tm) for BSP per kg of body weight are 10 times higher in rats and rabbits than in humans, whereas hepatic storage capacity is only about two-thirds that of humans (148, 149). There is a quantitative difference in bile composition between rodents (rats, rabbits) and humans, and although rats lack a gallbladder, their hepatic anatomy is quite similar to that in humans. The absence of gallbladder should not affect the liver uptake and clearance of compounds, however, since the gallbladder represents only a part of the extrahepatic biliary pathway. Spontaneous bile flow and composition in the dog are similar to those in the human (152), but Tm and storage capacity of BSP is three times higher in the dog than in the human (149, 153, 154), and the liver anatomy of the dog differs considerably from that of the human. The dog, because of its large size, however, could be used in studies in which percutaneous catheterization of hepatic vein, hepatic artery, and portal vein are necessary with use of a technique similar to that used in the human; moreover, studies can be carried out in a nonanesthetized state (155). Guinea pigs are not good models for hepatobiliary studies because their hepatic physiology is quite different from that of humans as well as from that of rats and rabbits. Hepatic anatomy

and physiology in the pig resemble that in the human more closely than it resembles that in the dog. The bile composition in the pig is very similar to that in the human, but hepatic Tm and storage capacity of BSP are about one half and two times higher, respectively, and bile flow is about three times higher in the pig than in the human (149, 156). Spontaneous bile flow and Tm of BSP are four times higher in sheep than in humans, but due to their large size and ease of manipulation, sheep models can be used when catheterization studies without the use of anesthesia are needed. In both anatomy and physiology, nonhuman primates mimic conditions similar to those in humans, but these models are used very seldom for physiological or pathophysiological studies (157, 158). When choosing a model for hepatobiliary studies, one should take into consideration factors such as the age of the animal, its body temperature, and types of anesthesia, any of which may affect the hepatobiliary function. It has been shown that with increasing age there is a decrease in hepatic transport and bile flow in rats (159). Certain anesthetics affect hepatobiliary function mainly by lowering body temperature (160) or by altering hepatic blood flow (161), gallbladder motility, bile flow, enzyme activity, and bilirubin and bile salt excretion (162, 163). In rats, ether and halothane caused a significant decrease in hepatobiliary excretion, but pentobarbital to a dose of 40 mg/kg did not show any effect. Some types of anesthesia affect gastroin-

testinal motility (pentobarbital in dogs, ketamine and/or sparine in rabbits). Of all the available animal models, dogs (and, to a lesser extent, rats) have been used more frequently than other animals to study hepatobiliary disease, due to ease of handling and the large size of their hepatobiliary system which permits catheterization. Animal models of hepatobiliary pathophysiology are summarized in Table 22.6 (164-180).

GENITOURINARY SYSTEM

Various species have been used for the study of kidney physiology and for the evaluation of radiopharmaceuticals. Although the mouse is available in most research laboratories, it has never been used as extensively as has the rat. In addition to the wealth of physiological data available on the rat, many rat models closely mimic diseases found in the human. Their low cost and availability enable the study of control

and experimental groups for tissue radioactivity assessment, scintigraphy, and autoradiography. In the evaluation of renal radiopharmaceuticals, young rats are used because of the increasing frequency with age of spontaneous glomerular sclerosis (181). The use of rabbits is restricted because their renal system differs from that in humans, in that the glomerular activity is intermittent, even in the adult rabbit. Increased water and salt intake induces activation of glomeruli, which results in copious diuresis (182, 183). The dog has been studied in the normal physiological state as well as in situations mimicking human disease. The dog is convenient for surgical experiments or for studies requiring the administration of fluid and the collection of urine from both or from each kidney separately (184).

Various models of human disease have been studied in rats. Renal failure has been produced by resection of 80% of the renal tissue or by bilateral ureteral ligation (185), but this proce-

Table 22.6.
Animal Models of Hepatobiliary Disease

Disease	Animals	Reference
Complete biliary obstruction	Dogs	164
Acute hepatic coma	Dogs	165
Prehepatic (hemolytic) jaundice	Dogs	166
Hepatoceellular jaundice:		
Acute hepatic necrosis		167-169
Hepatic cirrhosis		
Dimethylnitrosamine (DMNA) induced	Dogs	167-169
Alcohol induced	Rats, dogs	170, 171
Iron overload	Dogs	172
Hepatitis		
Alcohol induced	Dogs	170, 171
Virus induced	Marmosets, dogs	173, 174
Galactosamine induced	Mice	175
Fatty liver, lobar necrosis		
Carbon tetrachloride induced	Rats	176
Hepatic fibrosis	Rats	177
Hereditary and congenital defects:		
Crigler-Najjar syndrome (unconjugated hyperbilirubinemia)	Rats (Gunn rats, genetically inbred jaundiced rats)	178
Dubin-Johnson syndrome (congenital hyperbilirubinemia)	Sheep (mutant Corriedale)	179
Gilbert's syndrome (impaired hepatic uptake of unconjugated bilirubin)	Sheet (Southdown)	180

ture results in a relatively high mortality rate. Chemically induced renal failure (186) and tubular necrosis from the administration of gentamicin have been reported in rats (187).

Chronic glomerulonephritis with nephrotic syndrome has been produced in rats (188). In another rat model, a condition mimicking post-streptococcal glomerulonephritis was described (189). Models of pyelonephritis have been described in the rat (190) and the monkey (191), and experimental ureteral colic was induced in the dog in order to evaluate the significance of hydrostatic pressure, ureteral dilatation, mucosal response, and peristalsis (192). Changes in the hydrostatic pressure can be controlled and monitored, which thus mimics the severity of obstruction (193). Autoimmune nephritis in the rat can be induced by injection of renal tubular preparation in complete Freund's adjuvant (194). Hyperacute renal transplant rejection can be studied in a dog model (195). Papillary necrosis and cystic disease can be induced in the

rat (196, 197). Acute oliguric renal failure in the dog may be induced experimentally by infusion of norepinephrine into the renal artery (198), and renal artery stenosis can be produced by surgical placement of constricting clamps (199, 200), by use of inflatable cuffs (201), or by variations of these techniques. A percutaneous approach produces similar results. Thus a Swan-Ganz catheter placed in the renal artery can be used to produce various degrees of stenosis, with simultaneous monitoring of the pressure distal to the balloon (202). For the study of chronic stenosis, embolization of the renal artery has been produced experimentally (203). Experimental hypertension can be studied in the S-strain of rats developed by Dahl (66). When these rats are fed a high-salt diet, they develop hypertension, but rats fed a salt-poor diet remain normotensive and thus serve as genetically identical controls. In Table 22.7 are summarized the models of genitourinary diseases in large and small animals (66, 181-203).

Table 22.7.
Animal Models of Genitourinary Disease

Disease	Animal	Reference
Normal physiology:		
Evaluation of radiopharmaceuticals	Rats	181
Water and salt loading	Rabbits	182, 183
	Dogs	184
Renal failure	Rats	185, 186
Tubular necrosis	Rats	187
Glomerulonephritis:		
Chronic type, <i>N,N</i> -diacetylbenzidine	Rats	188
Poststreptococcal glomerulonephritis	Rats	189
Pyelonephritis	Rats	190
Pyelonephritis	Monkeys	191
Ureteral colic	Dogs	192
Obstructive uropathy	Dogs	193
Autoimmune nephritis	Rats	194
Hyperacute renal rejection	Dogs	195
Papillary necrosis	Rats	196
Cystic disease by diphenylamine feeding	Rats	197
Acute oliguric renal failure by norepinephrine	Dogs	198
Renal artery stenosis, clamp	Dogs	199, 200
Renal artery stenosis, cuff	Dogs	201
Renal artery stenosis, Swan-Ganz catheter	Dogs	202
Renal artery stenosis, embolization	Dogs	203
Hypertension, genetic	Rats	66

NUTRITIONAL-METABOLIC DISORDERS AND ENDOCRINE FUNCTIONS

Diabetes

Spontaneous diabetes is a common occurrence in many animal species, and experimental diabetes can be induced in animals by chemicals, hormones, injection of viruses, and surgery. Although hyperglycemia is a common feature of diabetes in animals, no syndrome in animals corresponds exactly to any of the forms of diabetes occurring in humans, which feature other abnormalities. The most common diabetic syndromes in obese animals are hyperinsulinemia and insulin resistance. The diabetes in lean animals is most frequently characterized by hypoinsulinemia, ketosis, and insulin dependence. Despite these differences, diabetic animals may be considered as models of disease in humans and may serve to advance research leading to the evaluation of tracer kinetics and metabolism in diabetic animals which will add to our knowledge and understanding of the pathophysiology of diabetes in humans. In addition, animal models (especially rodents) allow the study of many generations in a short period of time. These animal models permit study of the interaction between heredity and environmental factors such as diet, drugs, infectious agents, and toxins. Many obesity and diabetic models are available with use of rodents. Most of these animals, such as the Chinese hamster, mimic closely the nutrition-related and obesity-related maturity-onset type of diabetes seen in humans (204-206). The BB/W rat model and streptozotocin mouse model mimic the juvenile-onset insulin-dependent type of diabetes usually seen in adolescent humans (207-212). Although spontaneous diabetes is quite common in animals, only a few models have been used to characterize the disease process. Among the animal models available, the rodent model has been studied most thoroughly, mainly because (a) rodents have a short generation time and life-span, (b) their hyperglycemia and obesity are inherited, and (c) they are relatively inexpensive. Spontaneous diabetes in lean animals has been studied in BB rats, a spontaneous mutation of Wistar rats (211), guinea pigs (213),

Celebes apes (214), and keeshond dogs (215). Many experimental techniques are available for re-creation of the diabetes syndrome in animals.

The observation by Minkowski and Von-Mehring in 1889 that pancreatectomy in dogs results in polyuria, polydipsia, and glycosuria similar to those seen in human diabetes was, indeed, a milestone in the use of animals as models for the study of human disease. Diabetes can be induced experimentally by:

1. Contrainsulin hormones, viz., epinephrine, glucagon, glucocorticoids, growth hormone, and ACTH (216).
2. Virus (217).
3. Hypothalamic lesions: electrolytic or chemical (218, 219).
4. Toxic chemicals (207-210, 216, 220, 221).

In Table 22.8 are summarized spontaneously occurring and experimentally induced diabetes models (204-211, 216, 218-227). In Table 22.9 are summarized various diabetogenic chemical agents (207, 216, 220, 221).

Amyloidosis

Amyloidosis is a disease of unknown etiology characterized by the deposition of an abnormal protein-mucopolysaccharide complex within tissue parenchyma and around blood vessels. Although amyloidosis has been recognized as a pathological and clinical entity for over 100 years, only recently have detailed studies been carried out to understand the etiology, pathogenesis, and possible clinical importance of amyloid deposition. Amyloidosis usually involves multiple organ systems (particularly the kidneys, heart, liver, spleen, and brain). Although the etiology of amyloidosis in humans is not known, it is regarded as a disorder of protein metabolism; this includes (a) hyperglobulinemia, (b) an abnormality of the reticuloendothelial system, probably caused by chronic immunological stimulation resulting in the deposition of amyloid, (c) precipitation of antibody or antibody-antigen complexes, or (d) all of these. The disease exhibits several clinical types. Some show genetic predisposition, whereas others are associated with chronic inflammatory diseases, neoplasms, and the aging processes. Amyloidosis can occur spontane-

Table 22.8.
Some Common Animal Models of Diabetes

Disease Characteristics	Animal Model	Reference
Spontaneous:		
Metabolically similar to human juvenile-onset diabetes, very low plasma insulin, high ketosis, insulinitis; etiology: ?infection	BB rats (Bio-Breeding Lab, Canada)	211, 222, 223
Close resemblance to nutrition-related and obesity-related maturity-onset diabetes of middle age; intermittent glycosuria to ketosis, no insulinitis etiology: genetic	Chinese hamsters	204-206, 224, 225
High plasma insulin early, followed by low or normal later, no ketosis; etiology: genetic	Obese mice	225-227
Experimentally induced:		
Hypothalamic diabetes: similar to obesity caused by hypothalamic (ventromedial nuclei) lesion in human; obese, hyperglycemic, hyperinsulinemia; induction: electrolytic or chemical (goldthioglucose)	Rats mice, monkeys	218, 219
Toxic diabetes:		
Irreversible β -cell-specific toxins, insulinemia; induction: see Table 22.9	Dogs, mice	207-210, 216, 220, 221
Reversible β -cell-specific toxins		
Increased endogenous insulin requirement; induction: see Table 22.9		

ously in dogs (228) and in aged mice of certain strains (229, 230).

A variety of animals, when subjected to proper stimuli, have been shown to develop amyloidosis (231-237). Although the inoculating material usually is protein in nature, non-nitrogenous substances (viz., silicate and selenium) sometimes have been used, to induce amyloidosis (238). Since 1897, when Davidson reported finding a higher incidence of induced amyloidosis in mice than in other animals, the

mouse has been a favorite model for the study of amyloidosis (229, 230, 235-237, 239-241). In addition, laboratory mice frequently develop spontaneous amyloidosis which increases in frequency with age (229, 230, 242, 243), and this model has been suggested as being a valid model for human senile amyloidosis (242). Amyloidosis induced by repeated injection of casein in rabbits is histologically similar to the disorder in humans (236). A hybrid of the S/J and A strains of mice which develop spontane-

Table 22.9.
Diabetogenic Chemical Agents

Irreversible β -Cytotoxic Agents	Reversible β -Cytotoxic Agents	Other Agents	Reference
Alloxan	6-Aminonicotinamide	Anti-insulin antibodies	207, 216, 220,
Streptozotocin	L-Asparaginase	Somatostatin	221
Diphenylthiocarbazine	Azide	Catecholamines	
Oxine-9-hydroxyquinolone	Cyanide	Glucocorticoids	
Vacor	Cyproheptadine	Glucagon	
	Dehydroascorbic acid		
	Fluoride		
	Iodoacetate		
	Malonate		
	Thiazides		
	2-Deoxyglucose		
	Mannoheptulose		

ous amyloidosis has been suggested to be a useful model for the study of the relationship of amyloidosis, aging, and immune processes, especially to renal function (244). Spontaneous and induced amyloidosis models are listed in Table 22.10 (228-237, 244, 245).

Table 22.10.
Animal Models of Amyloidosis

Disease Characteristics	Animal Model	Reference
Spontaneous amyloidosis	Mice	229, 230, 244
Induced amyloidosis	Mice	235-237, 245
	Rabbits	232, 236
	Guinea pigs	233
	Cattle	228
	Horses	231
	Hamsters	234

Other Metabolic Diseases

There are very few animal models that have been utilized to study thyroid and parathyroid abnormalities. Congenital goiter has been reported in sheep, goats, and cattle (246-248). A model of diet-induced hyperparathyroidism in rats has been reported to be of value for the study of neonatal tetany (249). A rat model for the study of the skeletal resistance to vitamin D in renal failure has been developed by partial or total nephrectomy and has been suggested to be

a useful model for evaluating end-organ resistance to vitamin D in uremia (250).

HEMATOLOGIC DISORDERS

Experimental animal models of the hematopoietic system are limited mostly to the myeloid line and to the coagulation system. Other disorders have been studied in animals with inherited hematopoietic diseases, which have been perpetuated by breeding the affected animals.

Myelofibrosis with myeloid metaplasia can be induced in rabbits by the intravenous injection of saponin. The lesions produced resemble those found in humans with agnogenic myelofibrosis and metaplasia (251). Hemolytic anemia can be induced in rabbits by the injection of human anti-I cold agglutinins (252). Chemically induced chronic myelogenous leukemia can be produced in rats by feeding 2,7-diacetylaminofluorene (253). Cyclical neutropenia can be induced in dogs by injecting cyclophosphamide (254). Warfarin-resistant rats are bred for the study of vitamin K (255), while intravascular coagulation can be induced experimentally in the dog by endotoxin (256), which is very similar to the Shwartzman phenomenon in the rabbit (257). Blood pool agents can be studied more effectively in anesthetized dogs after splenectomy. Animal models of hematopoietic diseases are listed in Table 22.11 (251-257).

Table 22.11.
Animal Models of Hematopoietic System Disorders

Model	Animal	Reference
Myelofibrosis:		
Intravenous saponin	Rabbits	251
Hemolytic anemia:		
Injection of human anti-I cold agglutinins	Rabbits	252
Chronic myelogenous leukemia:		
Oral 2,7-diacetylaminofluorene	Rats	253
Cyclic neutropenia:		
Cyclophosphamide	Dogs	254
Warfarin resistance:		
Hereditary	Rats	255
Intravascular coagulopathy:		
endotoxin	Dogs	256
Rabbits		257
Blood pool agent evaluation:		
Splenectomy	Dogs	*

* Personal experience.

ONCOLOGY

Both in vitro and in vivo oncologic models have been used extensively for diagnostic and/or therapeutic studies. Mice and rats have been used most commonly as in vivo models, and hamsters, rabbits, and dogs have been used to a lesser extent (258). Induced, transplanted, or transmitted tumor models are used more frequently than are spontaneous tumor models, mainly because of availability. Transplanted or induced tumor models have certain definite advantages, e.g., the number of hosts is not limited, and the histological type of tumor to be studied as well as the anatomical location, tumor size, and host age can be selected. Gallagher et al. (259) has recently pointed out, however, that the commonly studied subcutaneous tumors are not realistic models for imaging studies, since the large tumor burden on the surface of the body does not occur in humans and therefore is not relevant to external detection by scintigraphy of regional and distant metastases and small primary tumors. Spontaneous tumor models, although rarely used, are closer to the actual tumors occurring in humans because of their type of blood supply, organ of origin, and systemic response to the presence of tumors. The most commonly used tumor models for studies of monoclonal antitumor antibodies are limited to murine or rat tumors as well as human tumor xenografts growing in

nude (athymic) or immunosuppressed mice. Human xenografts have been implanted at different sites in the body of mice (subcutaneous, intravascular, footpad, intrapineal, intracranial, intrasplenic). Bogden et al. (260, 261) developed a subrenal capsule model for rapid screening of new chemotherapeutic agents. More recently, this model has been used to investigate the radiolabeled monoclonal antibodies in solid lymphoma growing under the subrenal capsule of immunocompetent mice (259). This model shows promise in that the renal capsule provides a rich vascular supply which results in rapidly growing tumor and mimics more closely the deep-seated tumors in humans. A similar model has been developed in mice, with use of a sub-splenic capsule as the site of tumor cell transplant (262, 263). With the advantage of a highly vascular bed and easy accessibility, the hamster cheek pouch model has also been used quite often (264) to follow up the rate of growth and effect of therapeutic interventions (264).

The radiation-induced rat mammary tumor model perhaps best simulates radiation-induced breast cancer in the human female (265, 266). This model is based on demonstration that radiation exposure of the human female increases the risk of breast cancer development (267, 268). This technique similarly increases mammary carcinogenesis in the female rat. Furthermore, radiation-induced mammary carcinogenesis occurs by a scopol mechanism in both the

human female and the female rat (269–271). There is no evidence for a scopol mechanism in mice, dogs, and guinea pigs (272, 273). More recently, the hereditary asplenic mouse heterozygous for the nu gene has been shown to be a useful and relevant model of human breast cancer. A high percentage of these mice, starting at the age of 5 months, develop spontaneous breast carcinoma, with maximum incidence at the age of 10 months (available from the Armed Forces Institute of Pathology in Washington, D.C.) (274). Some models of induced and transplanted tumors are shown in Table 22.12 (264, 265, 269, 275–304).

SUMMARY

Animal models are used for the study of the normal metabolism and physiological processes as well as for the study of disease processes in humans. It is taken for granted that results obtained from experiments on animals which, in the phylogenetic scale, are close to humans, are more applicable than are results obtained from species that are more remote phylogenetically. Many conditions can be studied in rodents or other small animals, however, and the results obtained can still be valid for human conditions. It is the thorough knowledge of the anatomical and physiological variations of species that enables the choice of the appropriate animal model which will yield information that is statistically significant, is economical, and can be applied to the human in health and disease.

ACKNOWLEDGMENTS

Research was supported under the United States Department of Energy Contract No. DE-AC02-76CH00016.

REFERENCES

- Wessler S: Introduction: what is a model? In: *Animal Models of Thrombosis and Hemorrhagic Diseases*, Publication No (NIH) 76-982. Washington DC, HEW, 1975, pp xi–xv.
- Research Resources Reporter, U.S. Department of Health and Human Services, November 1983, pp 4–6.
- Jones TC, Hackel DB, Migaki AG (eds): *Handbook: Animal Models of Human Disease*, Fascicles 1–4. Washington DC, Registry of Comparative Pathology, Armed Forces Institute of Pathology, 1972–1975.
- Fredrickson JM, Honor AJ, Copp DH: Measurements

- of initial bone clearance of ⁴⁵calcium from blood in rat. *Fed Proc* 14:49, 1955.
- Copp DH, Shim SS: Quantitative studies of bone blood-flow in dogs and rabbits (abstract). *J Bone Joint Surg* 46B:781, 1964.
- Copp DH, Shim SS: Extraction ratio and bone clearance of ⁸⁵strontium as a measure of effective bone blood flow. *Circ Res* 16:461–467, 1965.
- VanDyke DG, Anger HO, Yano Y, et al: Bone blood flow shown with ¹⁸fluorine and the positron cameras. *Am J Physiol* 209:65–70, 1965.
- Kane WJ, Grim E: Quantitation of bone blood-flow in dogs. *Surg Forum* 16:447–448, 1965.
- White NB, Ter-Pogossian MM, Stein AH: A method to determine rate of blood flow in long bone and selected soft tissues. *Surg Gynecol Obstet* 119: 535–540, 1964.
- Lunde PKM, Michelsen K: Determination of critical blood flow in rabbit femur by radioactive microspheres. *Acta Physiol Scand* 80:39–44, 1970.
- Zolle I, Rhodes BA, Wagner HN Jr: Preparation of metabolizable radioactive human serum albumin microspheres for studies of the circulation. *Int J Appl Radiat Isot* 21:155–167, 1970.
- Riggins RS, DeNardo GL, D'Ambrosia GL, et al: Assessment of circulation in the femoral head by ¹⁸F scintigraphy. *J Nucl Med* 15:183–189, 1974.
- Gumerman LW, Fogel SR, Goodman MA, et al: Experimental fracture healing evaluation using radionuclide bone imaging. *J Nucl Med* 19:1320–1323, 1978.
- Oster ZH, Som P, Srivastava SC, et al: The development and in vivo behavior of tin-containing radiopharmaceuticals. II: autoradiographic and scintigraphic studies in normal animal models and in animal models of bone disease. *Int J Nucl Med Biol* 12:175–184, 1985.
- Najjar TA, Kahn DS: Experimental model for the study of osteogenesis and remodeling. *J Dent Res* 50:960–965, 1971.
- Norden CW: Experimental osteomyelitis. I. A description of the model. *J Infect Dis* 122:410–418, 1970.
- Bentley G: Papain-induced degenerative arthritis of the hip in rabbits. *J Bone Joint Surg* 53B:324–337, 1971.
- Hannan PCT, Huges BO: Reproducible polyarthritis in rats caused by *Mycoplasma arthritis*. *Ann Rheum Dis* 30:316–321, 1971.
- Miller ML, Ward JR, Cole BC, et al: Six-sulfanilamidoindazole induced arthritis and polyarthritis in rats: a new model of experimental inflammation. *Arthritis Rheum* 13:222–235, 1970.
- Kaye M, Silverton S, Rosenthal L: Technetium-99m pyrophosphate: studies in vivo and in vitro. *J Nucl Med* 16:40–45, 1975.
- Hardt AB: Early metabolic responses of bone to immobilization. *J Bone Joint Surg* 54A:119–124, 1972.
- Semb H: Experimental disuse osteoporosis. *Acta Soc Med Ups* 71:83–107, 1966.

Table 22.12.

Commonly Used Induced and Transplanted Tumor Models

Tumor Type	Animal Model	Reference
Adenocarcinoma	Mice, rats	265, 269, 275–278
Sarcoma	Mice	279–286
Melanoma	Mice, hamsters	277, 287–292
Glioma	Mice, rats	293, 294
Ehrlich ascites	Mice	295–297
Leukemia	Mice	298–300
Ependyoblastoma	Mice	298
Hepatoma	Rats	297, 301, 302
Squamous cell carcinoma	Hamster cheek pouch	264
Human tumors:		
Neuroblastoma, lymphoma, adenocarcinoma, schwannoma	Nude mice	303
Osteogenic sarcoma	Thymectomized mice	304

23. Landry M, Fleisch H: The influence of immobilization on bone formation as evaluated by osseous incorporation of tetracycline. *J Bone Joint Surg* 46B:764-771, 1964.
24. Utholf HK, Jaworski ZFG: Bone loss in response to long term immobilization. *J Bone Joint Surg* 60B:420-429, 1978.
25. Burkhart JM, Jowsey J: Parathyroid and thyroid hormones in the development of immobilization osteoporosis. *Endocrinology* 81:1053-1062, 1967.
26. Kazarian LE, VonGierke HE: Bone loss as a result of immobilization and chelation. Preliminary result in *Macaca mulatta*. *Clin Orthop Rel Res* 65:67-75, 1969.
27. Howard WH, Parcher JW, Young DR: Primate restraint system for studies of metabolic responses during recumbency. *Lab Anim Sci* 21:112-117, 1971.
28. Barzell V: Studies on osteoporosis—the long-term effect on oophorectomy and ammonium chloride ingestion in mature rats. *Endocrinology* 96:1304-1306, 1975.
29. Bissada NF, DeMarco TJ: The effect of a hypocalcemic diet on the periodontal structures of the adult rat. *J Periodont* 45:739-745, 1974.
30. Carnes WH, Pappenheimer AM, Stoerk HC: Volume of parathyroid glands in relation to dietary calcium and phosphorus. *Proc Soc Exp Biol Med* 51:514-516, 1946.
31. Gershon-Cohen J, Jowsey J: The relationship of dietary calcium to osteoporosis. *Metabolism* 13:221-226, 1964.
32. Miller DG, Gilmour RF, Grossman ZD, et al: Myocardial uptake of ^{99m}Tc skeletal agents in the rat after experimental induction of microscopic foci of injury. *J Nucl Med* 18:1005-1009, 1977.
33. Ronna G, Chappel CI, Balasz T, et al: An infarct-like myocardial lesion and other toxic manifestations produced by isoproterenol in the rat. *Arch Pathol* 67:443-455, 1959.
34. Adler N, Camin LL, Shulkin P: Rat model for acute myocardial infarction: application of technetium-labeled glucoheptonate, tetracycline and polyphosphate. *J Nucl Med* 17:203-207, 1976.
35. Davis MA, Holman BL, Carmel AN: Evaluation of radiopharmaceuticals sequestered by acutely damaged myocardium. *J Nucl Med* 17:911-917, 1976.
36. Grossman ZD, Foster AB, McAfee JG, et al: Myocardial uptake of six ^{99m}Tc-tagged pharmaceuticals and ⁸⁵Sr after vasopressin-induced necrosis. *J Nucl Med* 18:51-56, 1977.
37. Karsner HT, Duryer JE Jr: Studies in infarction. IV. Experimental bland infarction of the myocardium, myocardial regeneration and cicatrization. *J Med Res* 34:21-39, 1916.
38. Jennings RB, Wartman LB, Zudyk ZE: Production of an area of homogeneous myocardial infarction in the dog. *Arch Pathol* 63:580-585, 1957.
39. Jennings RB, Sommers H, Smyth GA, et al: Myocardial necrosis induced by temporary occlusion of a coronary artery in the dog. *Arch Pathol* 70:68-78, 1960.
40. Rees JR, Redding VJ: Experimental myocardial infarction by a wedge method: early changes in collateral flow. *Cardiovasc Res* 2:43-53, 1968.
41. Liedtke AJ, Nellis SH, Neely JR, et al: Effects of treatment with pyruvate and trimethamine in experimental myocardial ischemia. *Am J Cardiol* 40:716-726, 1977.
42. Carlsson E, Milne EN: Permanent implantation of endocardial tantalum screws: a new technique for functional studies of the heart in the experimental animal. *J Can Assoc Radiol* 18:304-307, 1967.
43. Hood WB Jr, Joison J, Kumar R, et al: Experimental myocardial infarction I: Production of left ventricular failure by gradual coronary occlusion in intact conscious dogs. *Cardiovasc Res* 4:73-83, 1970.
44. Green CE, Higgins CB, Kelley MJ, et al: Effects of intracoronary administration of contrast materials on left ventricular function in the presence of severe coronary artery stenosis. *Cardiovasc Intervent Radiol* 4:110-116, 1981.
45. Zollkoffer C, Castaneda-Zuniga W, Vloderav Z: Experimental myocardial infarction in the closed-chest dog: a new technique. *Invest Radiol* 16:7-12, 1981.
46. Cohen MV, Eldh P: Experimental myocardial infarction in the closed-chest dog: controlled production of large or small areas of necrosis. *Am Heart J* 86:798-804, 1973.
47. Bergman SR, Lerche RA, Mathias CI, et al: Noninvasive detection of coronary thrombi with ¹¹¹In platelets. *J Nucl Med* 24:130-135, 1983.
48. Vatner SF, Franklin D, Higgins CB, et al: Left ventricular response to severe exertion in untethered dogs. *J Clin Invest* 51:3052-3060, 1972.
49. Vatner SF, Franklin D, Higgins CB, et al: Coronary dynamics in unrestricted conscious baboons. *Am J Physiol* 221:1396-1401, 1971.
50. Hill JD, Malinow MR, McNulty WP, et al: Experimental myocardial infarction in unanesthetized monkeys. *Am Heart J* 84:82-94, 1972.
51. Schaper W, Jageneux A, Xhonneux R: The development of collateral circulation in the pig and dog heart. *Cardiologia* 51:321-335, 1967.
52. Lumb CD, Hardy LB: Collateral circulation and survival related to gradual occlusion of the right coronary artery in the pig. *Circulation* 27:717-721, 1963.
53. Savage RM, Guth B, White FC, et al: Correlation of regional myocardial blood flow and infarct size during acute myocardial ischemia in the pig. *Circulation* 64:699-707, 1981.
54. Josué O: Athérome aortique expérimental par injections répétées d'adrénaline dans les veins. *C R Soc Biol (Paris)* 55:1374-1376, 1903.
55. Ignatovski A: Influence de la nourriture animale sur l'organisme de lapin. *Arch Med Exp* 20:1-20, 1908.
56. Selye H: Knochenveränderungen bei den Jungen vigantol-behandelter Tiere. *Med Klin* 25:167-168, 1929.
57. Hartford WS, O'Neal RM: Experimental production of coronary atherosclerosis. *Am J Cardiol* 9:355-364, 1962.
58. Besterman EMM: Experimental coronary atherosclerosis in rabbits. *Atherosclerosis* 12:75-83, 1970.
59. Lee KT, Jarmolych J, Kim DN, et al: Production of advanced coronary atherosclerosis, myocardial infarction and "sudden death" in swine. *Exp Mol Pathol* 15:170-190, 1971.
60. Younger RK, Scott HW Jr, Butts WH, et al: Rapid production of experimental hypercholesterolemia and atherosclerosis in the rhesus monkey: comparison of five dietary regimens. *J Surg Res* 9:263-270, 1969.
61. Goldblatt H: Studies on experimental hypertension. V. The pathogenesis of experimental hypertension due to renal ischemia. *Ann Intern Med* 11:69-103, 1937.
62. Grollman A: The role of the kidney in the pathogenesis of hypertension as determined by a study of the effect of nephrectomy on the blood pressure of normal and hypertensive animals. In Zweifach BW and Shorr E (eds): *Factors Regulating Blood Pressure*. Found, NY, Josiah Macy Jr, 1948, pp 41-60.
63. Friedman SM, Friedman CL: Self-sustained hypertension in the albino rat: a hypothesis to explain it. *Can Med Assoc J* 61:596-600, 1949.
64. Friedman B, Jarman J, Klemperer P: Sustained hypertension following experimental unilateral renal injury. *Am J Med Sci* 202:20-29, 1941.
65. Grollman A: A simplified procedure for inducing chronic renal hypertension in the mammal. *Proc Soc Exp Biol Med* 57:102-104, 1944.
66. Dahl LK: Experimental hypertension in the rat. *Can Heart Assoc J* 90:155-160, 1964.
67. Ehrlich FE, Kramer SG, Watkins E Jr: An experimental shock model simulating clinical hemorrhagic shock. *Surg Gynecol Obstet* 129:1173-1180, 1969.
68. David MS: Experimental coronary artery thrombosis for production of cardiogenic shock. *Can J Surg* 13:189-194, 1970.
69. Vishnevskaja OP, Jvschenko NA: Concerning the mechanism producing an adrenalin myocarditis. *Bull Exp Biol Med* 44:932-936, 1957.
70. D'Amato L: Weitere Untersuchungen über de von den Nebennierenextracten bewirkten Veränderungen der Blutgefäße und anderer Organe. *Berl Klin Wochenschr* 1100-1102, 1131-1134, 1906.
71. Gilbert A, Lion G: Artérite infectieuse expérimentale. *C R Soc Biol (Paris)* 41:583-584, 1889.
72. Keys TF, Sapico FL, Touchon R, et al: Experimental endocarditis. I. Description of a canine model. *Am J Med Sci* 63:103-109, 1972.
73. Garrison PK, Freeman LR: Staphylococcal endocarditis in rabbits resulting from placement of a polyethylene catheter in the right side of the heart. *Yale J Biol Med* 42:394-409, 1970.
74. Luginbühl H, Detweiler DK: Cardiovascular lesions in the dog. *Ann NY Acad Sci* 127:517-540, 1965.
75. Beco L: Ueber die Actiologie der urämischer Pericarditis. *Zentralbl Allg Pathol Anat* 5:839-842, 1894.
76. Mohiuddin SM, Taskar PK, Rheault M, et al: Experimental cobalt cardiomyopathy. *Am Heart J* 80:532-543, 1970.
77. Andrews EJ, Ward BC, Altman NH (eds): *Spontaneous Animal Models of Human Disease*. New York, Academic Press, 1979, vol II, pp 106-178.
78. Frankhauser R, Luginbühl H, McGrath JT: Cerebrovascular disease in various animal species. *Ann NY Acad Sci* 127:817-860, 1965.
79. French JF, Jennings MA, Poole JCF, et al: Intimal changes in arteries of aging pigs. *Proc R Soc Edinburgh [Bio Sci]* 158:24-42, 1963.
80. Luginbühl H, Pauli B, Ratcliffe HL: Atherosclerosis in swine and swine as a model for the study of atherosclerosis. *Adv Cardiol* 13:119-126, 1974.
81. Nam SC, Lee WM, Jarmolych J, et al: Rapid production of advanced atherosclerosis in swine by a combination of endothelial injury and cholesterol feeding. *Exp Mol Pathol* 18:369-379, 1973.
82. Okamoto K, Yamori K, Nagaoka A: Establishment of the stroke-prone spontaneously hypertensive rat (SHR). *Circ Res* 34-35(Suppl 1):143-153, 1974.
83. Martin JR, Nathanson N: Animal models of virus induced demyelination. *Prog Neuropathol* 4:27-50, 1979.
84. Johnson RT, Narayan O: Experimental neurological disease of animals caused by virus. In Klawans HL Jr (ed): *Models of Neurological Disease*. Amsterdam, Excerpta Medica, 1974, pp 39-87.
85. Gropp A: Animal model of human disease: Autosomal trisomies in fetal mice, exencephaly in mice with trisomy. *Am J Pathol* 77:539-542, 1974.
86. McGlure HM: Animal model for human disease: trisomy in a chimpanzee. *Am J Pathol* 67:413-416, 1972.
87. Brizzee KR, Ordy JM, Hoffer H, et al: Animal models for the study of senile brain disease and aging changes in brain. In Katzman R, Terry RD, Bick KL (eds): *Alzheimer's Disease: Senile Dementia and Related Disorders*. New York, Raven Press, 1978, pp 515-553.
88. Wisniewski HM, Johnson AB, Raine CS, et al: Senile plaques and cerebral amyloidosis in aged dogs: a histochemical and ultra structural study. *Lab Invest* 23:287-296, 1970.
89. Wisniewski HH, Ghetti B, Terry RD: Neuritic (senile) plaques and filamentous changes in aged monkeys. *J Neurol Neurosurg* 32:566-584, 1973.
90. Wisniewski HM: The aging brain. In Andrews EJ, Ward BC, Altman NH (eds): *Spontaneous Animal Models of Human Disease*. New York, Academic Press, 1979, vol II, pp 148-152.
91. Som P, Hosain F, Wagner HN Jr: Accelerated clearance of radioactive chelate from cerebrospinal fluid in experimental meningitis. *J Nucl Med* 13:942-944, 1972.
92. Balch AL, Fuller T, Osborne W: Immunologic studies of cerebrospinal fluid proteins in experimental aseptic meningitis in dogs. *J Lab Clin Med* 73:883-892, 1969.

93. Baringer JR, Griffith JF: Experimental measles virus encephalitis. A light, phase, fluorescence, and electron microscopic study. *Lab Invest* 23:335-346, 1970.
94. Price DL, James AE, Sperber E, et al: Communicating hydrocephalus, cisternographic and neuropathologic studies. *Arch Neurol* 33:15-20, 1976.
95. Chamberlain JG: Early neurovascular abnormalities underlying 6-aminonicotinamide (6-AN)-induced congenital hydrocephalus in rats. *Teratology* 3:377-388, 1970.
96. Harrington DD, Newberne PM: Correlation of maternal blood levels of vitamin A at conception and the incidence of hydrocephalus in newborn rabbits: an experimental animal model. *Lab Anim Care* 20:675-680, 1970.
97. Siegel BA, Meidinger R, Elliott AJ, et al: Experimental cerebral microembolism. Multiple tracer assessment of brain edema. *Arch Neurol* 26:73-77, 1972.
98. Watanabe S, Shimada H, Ishii S: Production of clinical form of chronic subdural hematoma in experimental animals. *J Neurosurg* 37:552-561, 1972.
99. Grimm RJ, Frazee JG, Kawasaki T, et al: Cobalt epilepsy in the squirrel monkey. *Electroenceph Clin Neurophysiol* 29:525-528, 1970.
100. Swenberg JA, Loestner A, Wechsler W: The induction of tumors of the nervous system with intravenous methylnitrosourea. *Lab Invest* 26:74-85, 1972.
101. Ausman JI, Shapiro WR, Roll DP: Studies on the chemotherapy of experiment brain tumors: development of an experimental model. *Cancer Res* 30:2394-2400, 1970.
102. McLaughlin RF, Tyler WS, Canada RO: A study of the subgross pulmonary anatomy in various animals. *Am J Anat* 108:149-165, 1961.
103. Castleman WL, Dungworth DL, Tyler WS: Intrapulmonary airway morphology in three species of monkeys. *Am J Anat* 142:107-121, 1975.
104. Dodds WJ: Platelet function in animals: species specificities. In Gaetano G, Garattini S (eds): *Platelets: A Multidisciplinary Approach*. New York, Raven Press, 1978, pp 45-59.
105. Stauson DO, Hahn FF: Criteria for development of animal models of disease of the respiratory system. *Am J Pathol* 101:S103-S122, 1980.
106. Siegel ME, Malmud LS, Rhodes BA, et al: Scanning of thrombocytosis with ¹³¹I-streptokinase. *Radiology* 103:695-696, 1972.
107. Coleman RE, Harwig SS, Harwig JF, et al: Fibrinogen uptake by thrombi: effects of thrombus age. *J Nucl Med* 16:370-373, 1975.
108. Sheppard BC, Freuch JE: Platelet adhesion in the rabbit abdominal aorta following removal of endothelium: a scanning and transmission electron microscopic study. *Proc R Soc Lond [Biol]* 176:427, 1971.
109. Hislop A, Reid L: Changes in pulmonary arteries of the rat during recovery from hypoxia pulmonary hypertension. *Br J Exp Pathol* 58:653-662, 1977.
110. Hislop A, Reid L: Arterial changes in *Crotalaria spectabilis* induced pulmonary hypertension in rats. *Br J Exp Pathol* 55:153-163, 1974.
111. Slavson DO: Naturally-occurring hyaline membrane disease syndromes in foals and piglets. *J Pediatr* 95:889-891, 1979.
112. McAdams AJ, Coen R, Kleinman LI, et al: The experimental production of hyaline membranes in premature rhesus monkeys. *Am J Pathol* 73:277-290, 1973.
113. Nettesheim P, Hammons AS: Induction of squamous cell carcinoma in the respiratory tract of mice. *J Natl Cancer Inst* 47:697-701, 1971.
114. Patterson R: Laboratory models of reaginic allergy. *Proc Allergy* 13:332-407, 1969.
115. Richardson JB, Hogg JC, Bouchard T, et al: Localization of antigen in experimental bronchoconstriction in guinea pigs. *J Allergy Clin Immunol* 52:172-181, 1973.
116. Patterson R, Kelly JF: Animal models of the asthmatic state. *Ann Rev Med* 25:53-68, 1974.
117. Lindsey JR, Baker HJ, Oversach RG, et al: Murine chronic respiratory disease. Significance as a research complication and experimental production with *Mycoplasma pulmonis*. *Am J Pathol* 64:675-706, 1971.
118. Pirie HM, Wheelton EB: Chronic bronchitis in the dog. *Adv Vet Sci Comp Med* 20:253-276, 1976.
119. Senior RM, Tegner H, Kuhn C, et al: The induction of pulmonary emphysema with human leukocyte elastase. *Am Rev Respir Dis* 116:469-475, 1977.
120. Pirie HM, Selman IE: A bovine pulmonary disease resembling human diffuse fibrosing alveolitis. *Proc Soc Med* 65:987-989, 1972.
121. Marco V, Meranze DR, Yoshida M, et al: Papain-induced emphysema in the dog. *J Appl Physiol* 33:293-299, 1972.
122. McCall CE, Taylor RG, Cousart SL, et al: Acute respiratory distress syndrome, Model 275. In Capen CC, Hackel DB, Jones TC, Migaki G (eds): *Handbook: Animal Models of Human Disease*, Fascicle 12. Washington DC, Registry of Comparative Pathology, Armed Forces Institute of Pathology, 1983.
123. Reisfeld IH, Brodowsky BJ: Pulmonary fibrosis, Model No 262. In Capen CC, Hackel DB, Jones TC, Migaki G (eds): *Handbook: Animal Models of Human Disease*, Fascicle 12. Washington DC, Registry of Comparative Pathology, Armed Forces Institute of Pathology, 1983.
124. Chevillat NF: Criteria for development of animal models of disease of the gastrointestinal system. *Am J Pathol* 101:S67-S76, 1980.
125. Bauner BF, Alroy J, Pauli BU, et al: An ultrastructural study of acinar cell carcinomas of the canine pancreas. *Am J Pathol* 93:165-182, 1978.
126. Hashimoto A, Osada K, Fujimoto Y: Juvenile acinar atrophy of the pancreas of the dog. *Vet Pathol* 16:74-80, 1979.
127. Wanke M: Experimental acute pancreatitis. *Curr Top Pathol* 52:65-142, 1970.
128. Tsui C-Y, Burch GE, Harb JM: Pancreatitis in mice injected with coxsackie virus B. *Arch Pathol* 93:379-389, 1972.
129. Sarles H, Lebreuil G, Tasso F, et al: A comparison of alcoholic pancreatitis in rat and man. *Gut* 12:377-388, 1971.
130. Goldberg HI: Controlled production of acute esophagitis. Experimental animal model. *Invest Radiol* 5:254-256, 1970.
131. Okabe S, Pfeiffer CJ: The acetic acid ulcer model—a procedure for chronic duodenal or gastric ulcer. In Pfeiffer CJ (ed): *Peptic Ulcer*. Copenhagen, Munksgaard, 1971.
132. Okabe S, Roth JLA, Pfeiffer CJ: Differential healing periods of the acetic acid ulcer model in rats and cats. *Experientia* 27:146-148, 1971.
133. Sethbhakdi S, Pfeiffer CJ: Gastric mucosal ulceration following vasoactive agents. A new experimental model. *Am J Dig Dis* 15:261-270, 1970.
134. Yasin RL, Leese CL: The production of chronic gastritis and ulceration in the glandular stomach of rats by iodoacetamide (IAM). *Eur J Cancer* 6:425-432, 1970.
135. Szabo S: Animal model of human disease: duodenal ulcer disease: animal model: cysteamine-induced acute and chronic duodenal ulcer in the rat. *Am J Pathol* 93:273-276, 1978.
136. Szabo S, Haith LR Jr, Reynolds ES: Pathogenesis of duodenal ulceration produced by cysteamine or propionitrile: influence of vagotomy, sympathectomy, histamine depletion, H₂ receptor antagonists and hormones. *Am J Dig Dis* 24:471-477, 1979.
137. Miskowiak J, Nielsen SL, Munck O, et al: Abdominal scintigraphy with ^{99m}Tc-labelled albumin in acute gastrointestinal bleeding. An experimental study and a case report. *Lancet* 2:852-854, 1977.
138. Alavi A, Dan RW, Baun S, et al: Scintigraphic detection of acute gastrointestinal bleeding. *Radiology* 124:753-756, 1977.
139. Som P, Oster ZH, Atkins HL, et al: Detection of gastrointestinal blood loss with ^{99m}Tc-labeled heat treated red blood cells. *Radiology* 138:207-209, 1981.
140. Kelly M, Butler DG, Hamilton JR: Transmissible gastroenteritis in piglets: a model of infantile viral diarrhea. *J Pediatr* 80(6):925-931, 1972.
141. Wilson SE, Hiatt J, Winston M: Intestinal blood-flow: an evaluation by clearance of xenon-133 from canine jejunum. *Arch Surg* 110:797-801, 1975.
142. Fritzberg AR, Whitney WP, Klingensmith WC: Hepatobiliary transport mechanism of Tc-99m N,α-(2,6-diethylacetanilide)-iminodiacetic acid (Tc-99m-diethyl IDA). In Sodd VJ, Hoogland DR, Allen DR, et al (eds): *Radiopharmaceuticals II*. New York, Society of Nuclear Medicine, 1979, pp 577-586.
143. Kato-Azuma M: Tc-99m (Sn)-N-pyridoxylamine: a new series of hepatobiliary imaging agents. *J Nucl Med* 23:517-524, 1982.
144. Smith RB, Coupl J, Deland FH, et al: Pharmacokinetics of hepatobiliary agents in rats, concise communication. *J Nucl Med* 20:45-49, 1979.
145. Cardide VJ, Taylor W, Cramer JA, et al: Evaluation of liposome radiopaque tracers as scanning agents. Part 1: organ distribution of liposomes (^{99m}Tc-DTPA) in mice. *J Nucl Med* 17:1067-1072, 1976.
146. Schachner ER, Gil MC, Atkins HL, et al: Ruthenium-97 hepatobiliary agents for delayed studies of the biliary tract. I Ru-97 PIPIDA: concise communication. *J Nucl Med* 22:352-357, 1981.
147. Forker EL, Hicklin T, Sornson II: The clearance of mannitol and erythritol in rat bile. *Proc Soc Exp Biol Med* 126:115-119, 1967.
148. Klaassen CD, Plaa GL: Species variation in metabolism, storage and excretion of sulfobromophthalein. *Am J Physiol* 213:1322-1326, 1967.
149. Preisig R, William R, Sweeting J, et al: Quantitative approach to the study of liver function in normal man during the course of hepatitis and other forms of liver disease. *Gastroenterology* 44:479, 1963.
150. Smith RL: Species variations in biliary excretion. In: *The Excretory Function of Bile: The Elimination of Drugs and Toxic Substances in Bile*. London, Chapman and Hall, 1973, pp 76-93.
151. Aziz FTA, Hirom PC, Millburn P, et al: The biliary excretion of anions of molecular weight 300-800 in the rat, guinea pig and rabbit. *Biochem J* 125:25P-26P, 1971.
152. Wheeler HO, Ramos OL: Determinants of the flow and composition of bile in unanesthetized dog during constant infusions of sodium taurocholate. *J Clin Invest* 39:161-169, 1966.
153. Preisig R, William R, Sweeting J, et al: Changes in sulfobromophthalein transport and storage by the liver during viral hepatitis in man. *Am J Med* 40:170-183, 1966.
154. Gocke DJ, Preisig R, Morris TQ: Experimental viral hepatitis in the dog: production of persistent disease in partially immune animals. *J Clin Invest* 46:1506-1517, 1967.
155. Berk RN, Loeb PM, Cobo-Frankel, et al: The biliary and urinary excretion of iopanoic acid: pharmacokinetics, influence of bile salts and choleretic effect. *Radiology* 120:41-47, 1976.
156. Erlinger S, Dhumeaux D: Mechanism and control of secretion of bile water and electrolytes. *Gastroenterology* 66:281-304, 1974.
157. VanHeertum RL, Subramanian G, Thomas FD, et al: Comparative evaluation of Tc-99m labeled hepatobiliary agents with ¹³¹I rose bengal. *J Nucl Med* 16:577, 1975.
158. Wistow BW, Subramanian G, VanHeertum RL, et al: An evaluation of ^{99m}Tc-labeled hepatobiliary agents. *J Nucl Med* 18:455-461, 1977.
159. Fischer E, Barth A, Varga F, et al: Age dependence of hepatic transport in control and phenobarbital-treated rats. *Life Sci* 24:557-562, 1979.
160. Roberts RJ, Klaassen CD, Plaa GL: Maximum biliary excretion of bilirubin and sulfobromophthalein during

- anaesthesia induced alteration of rectal temperature. *Proc Soc Exp Biol Med* 125:313-316, 1967.
161. Paterson JYF, Harrison FA: The splanchnic and hepatic uptake of cortisol in conscious and anaesthetized sheep. *J Endocrinol* 55:335-350, 1972.
162. Cooper B, Eakins MN, Slater TF: The effect of various anaesthetic techniques on the flow rate, constituents and enzyme composition of rat bile. *Biochem Pharmacol* 25:1711-1718, 1976.
163. Roberts RJ, Plaa GL: Effect of phenobarbital on the excretion of an exogenous bilirubin load. *Biochem Pharmacol* 16:827-835, 1967.
164. Klingensmith WC III, Whitney WP, Spitzer VM, et al: Effect of complete biliary-tract obstruction on serial hepatobiliary imaging in experimental model: concise communication. *J Nucl Med* 22:866-868, 1981.
165. Mistra HK, Peng FK, Sayhonn A, et al: Acute hepatic coma: a canine model. *Surgery* 72:634-642, 1972.
166. Burgner FA: Intact animal models of normal and abnormal biliary excretion. In Milne ENC (ed): *Models and Techniques in Medical Imaging Research*. New York, Praeger, 1983, p 407.
167. Madden JW, Gertman PM, Peacock EE Jr: Dimethylnitrosamine-induced hepatic cirrhosis: a new canine model of an ancient human disease. *Surgery* 68:260-268, 1970.
168. Burgner FA, Fischer HW: Intravenous cholangiography in normal and subsequently liver damaged dogs. *Radiology* 114:519-524, 1975.
169. Burgner FA, Fischer HW: Biliary excretion of iodopamide and iodoxamate in dogs with hepatic dysfunction induced by oral administration of dimethylnitrosamine. *Invest Radiol* 15:162-167, 1980.
170. Porta EA, Koch OR, Hartroft WS: A new experimental approach in the study of chronic alcoholism. IV. Reproduction of alcoholic cirrhosis in rats and the role of lipoprotein versus vitamins. *Lab Invest* 20:562-572, 1969.
171. Chey WY, Kosay S, Siple H, et al: Observations on hepatic histology and function in alcoholic dogs. *Am J Dig Dis* 16:835-838, 1971.
172. Lisboa PE: Experimental hepatic cirrhosis in dogs caused by chronic massive iron overload. *Gut* 12:363-368, 1971.
173. Mohr JR, Mattenheimer H, Holmes AW, et al: Enzymology of experimental liver disease in marmoset monkeys. II: Experimental hepatitis. *Enzyme* 12:161-179, 1971.
174. Morris T, Gocke DJ: Modified acute canine viral hepatitis—a model for physiologic study. *Proc Soc Exp Biol Med* 139:32-36, 1971.
175. Monier D, Wagle SR: Studies on gluconeogenesis in galactosamine induced hepatitis. *Proc Soc Exp Biol Med* 136:377-380, 1971.
176. McLean EK, McLean AEM, Sutton MP: Instant cirrhosis: an improved method for producing cirrhosis of the liver in rats by simultaneous administration of carbon tetrachloride and phenobarbitone. *Br J Exp Pathol* 50:502-506, 1969.
177. Yermakoff JK, Fuller GC, Rodil JV: An experimental model of hepatic fibrosis induced by the administration of dibutyltin dichloride. *Toxicol Appl Pharmacol* 49:31-40, 1979.
178. Bissell DM: Formation and elimination of bilirubin. *Gastroenterology* 69:519-538, 1975.
179. Alpert S, Mosher M, Shanske A: Multiplicity of hepatic excretory mechanisms for organic ions. *J Gen Physiol* 53:288-247, 1969.
180. Mia AS, Gronwall RR, Cornelius CE: Bilirubin-¹⁴C turnover studies in normal and mutant Southdown sheep with congenital hyperbilirubinemia. *Proc Soc Exp Biol Med* 133:955-959, 1970.
181. Bolton WK, Benton FR, Macklay JG, et al: Spontaneous glomerular sclerosis in aging Sprague-Dawley rats. *Am J Pathol* 85:277-300, 1976.
182. Dicker SE, Heller H: Relationship between glomerular filtration rate and urine flow in the rabbit. *Science* 112:340-341, 1935.
183. Brewer NR: Some oddities of the rabbit kidney. *Synapse* 10:19-22, 1977.
184. McAfee JG, Grossman ZD, Gagne G, et al: Comparison of renal extraction efficiency of radioactive agents in the normal dog. *J Nucl Med* 22:333-338, 1981.
185. Giacomini KM, Roberts SM, Levy G: Evaluation of methods for producing renal dysfunction in rats. *J Pharm Sci* 89:424-427, 1981.
186. Dobyanc DC, Levi J, Jacobs C, et al: Mechanism of cis-platinum nephrotoxicity. II. Morphologic observations. *J Pharmacol Exp Ther* 213:551-556, 1980.
187. Black J, Calesnik B, Williams D, et al: Pharmacology of gentamicin, a new broad-spectrum antibiotic. In Sylvester JC (ed): *Antimicrobial Agents and Chemotherapy—1963*. Ann Arbor, MI, Society for Microbiology, 1964, pp 138-147.
188. Harman JW: Chronic glomerulonephritis and the nephrotic syndrome in rats with *N*, *N*-1-di-acetylbenzidine. *J Pathol* 104:119-128, 1971.
189. Vosti KL, Lindberg LH, Kosek JC, et al: Experimental streptococcal glomerulonephritis: longitudinal study of a laboratory model resembling human acute post-streptococcal glomerulonephritis. *J Infect Dis* 122:249-259, 1970.
190. Burrows SE, Cawein JB: Rat pyelonephritis model suitable for primary or secondary screening. *Appl Microbiol* 18:448-451, 1969.
191. Roberts JA, Clayton JD, Domingue GJ: Experimental pyelonephritis in the monkey. *Invest Urol* 9:449-453, 1972.
192. Kim HL, Labay PC, Boyarsky S, et al: An experimental model of urethral colic. *J Urol* 104:390-394, 1970.
193. Jones SE, Lilien OM, Rogers L: Renal pelvic pressure and its relation to renal hemodynamics. *J Urol* 90:357-360, 1963.
194. Barabas AZ, Lannigan R: Auto-immune nephritis in rats. *J Pathol* 97:537-543, 1969.
195. Barkin M, Jeffs RD, Hambley EJ: A model for the study of hyperacute renal rejection. *Invest Urol* 9:475-479, 1972.
196. Murray G, Wyllie RG, Hill GS, et al: Experimental papillary necrosis of the kidney. I. Morphologic and functional data. *Am J Pathol* 67:285-302, 1972.
197. Safouh M, Crocker JFS, Vernier RL: Experimental cystic disease of the kidney. *Lab Invest* 23:392-400, 1970.
198. Knapp R, Hollenberg NK, Busch GJ, et al: Prolonged unilateral acute renal failure induced by intra-arterial norepinephrine infusion in the dog. *Invest Radiol* 7:164-173, 1972.
199. Goldblatt H, Lynch J, Hanzal R, et al: Studies on experimental hypertension. The production of persistent elevation of systolic blood pressure by means of renal ischemia. *J Exp Med* 59:347-379, 1934.
200. Mulieri LA, Korol B: A new renal artery clamp applicator. *J Appl Physiol* 18:1033-1034, 1963.
201. Shapiro R, Doppman J, Cobb R, et al: Major segmental renal arterial constriction: an experimental study in the dog. *Radiology* 85:462-469, 1965.
202. Korobkin M, Shauser JD: Controlled unilateral renal artery hypertension in dogs. *Radiology* 111:457-460, 1974.
203. Hellsten S, Nylander G, Wulff K: A percutaneous intra-arterial technique for producing renal artery stenosis. *Acta Chir Scand* 142:375-379, 1976.
204. Gerritsen GC, Blanks MC: Characterization of Chinese hamsters by metabolic balance, glucose tolerance and insulin secretion. *Diabetologia* 10:493-499, 1974.
205. Gerritsen GC, Johnson MA, Soret MG, et al: Epidemiology of Chinese hamsters and preliminary evidence for genetic heterogeneity of diabetes. *Diabetologia* 10:581-588, 1974.
206. Gerritsen GC, Needham LB, Schmidt FL, et al: Studies on prediction and development of diabetes in offspring of diabetic Chinese hamsters. *Diabetologia* 6:158-162, 1970.
207. Like AA, Rossini AA: Streptozotocin-induced pancreatic insulinitis: new model of diabetes mellitus. *Science* 193:415-417, 1976.
208. Rossini AA, Appel MC, Like AA: Genetic influence of the streptozotocin-induced insulinitis and hyperglycemia. *Diabetes* 26:916-920, 1977.
209. Rossini AA, Like AA, Chick WL, et al: Studies of streptozotocin-induced insulinitis and diabetes. *Proc Natl Acad Sci* 74:2485-2489, 1977.
210. Like AA, Appel MC, Williams RM, et al: Streptozotocin-induced pancreatic insulinitis in mice: morphologic and physiologic studies. *Lab Invest* 38:470-486, 1978.
211. Rossini AA, Williams RM, Mordes JP, et al: Spontaneous diabetes in gnotobiotic BB/W rat. *Diabetes* 28:1031-1032, 1979.
212. Klopel G: Experimental insulinitis, secondary diabetes: the spectrum of the diabetic syndrome. In Podolsky S, Viswanathan M (eds): *Secondary Diabetes*. New York, Raven Press, 1980, pp 493-501.
213. Lang CM, Munger BL: Diabetes mellitus in the guinea pig. *Diabetes* 25:434-443, 1976.
214. Howard CF: Insular amyloidosis and diabetes mellitus in *Macaca nigra*. *Diabetes* 27:357-364, 1978.
215. Kramer JW, Nottingham S, Robinette J, et al: Inherited, early onset, insulin-requiring diabetes mellitus of keeshond dogs. *Diabetes* 29:558-565, 1980.
216. Dulin WE, Soret MG: Chemically and hormonally induced diabetes. In Volk BW, Wellman KF (eds): *The Diabetic Pancreas*. New York, Plenum Press, 1977, pp 425-465.
217. Notkins AL: Virus-induced diabetes mellitus: brief review. In Podolsky S, Viswanathan M (eds): *Secondary Diabetes*. New York, Raven Press, 1980, pp 471-486.
218. Hales CN, Kennedy GC: Plasma glucose, non-esterified fatty acid and insulin concentrations in hypothalamic-hyperphagic rats. *Biochem J* 90:620-624, 1964.
219. Hamilton CL: An observation of long-term experimental obesity and diabetes in the monkeys. *J Med Prim* 1:247-255, 1972.
220. Fischer LJ, Rickert DE: Pancreatic islet-cell toxicity. *CRC Crit Rev Toxicol* 3:231-263, 1975.
221. Rossini AA, Williams RM, Mordes JP, et al: Animal models of insulin dependent diabetes. In Waldhauf WK (ed): *Diabetes*. Amsterdam, Excerpta Medica, International Congress Series No 500, 1980, pp 367-372.
222. Nakhoda AF, Like AA, Chapel CI, et al: The spontaneously diabetic Wistar rats. *Diabetes* 26:100-112, 1977.
223. Like AA: Spontaneous diabetes in animals. In Volk BW, Wellman KF (eds): *The Diabetic Pancreas*. New York, Plenum Press, 1977, pp 381-423.
224. Gerritsen GC, Dulin WE: Characterization of diabetes in the Chinese hamsters. *Diabetologia* 3:78-84, 1967.
225. Renold AE: Spontaneous diabetes and/or obesity in laboratory rodents. In Levine R, Luff R (eds): *Advances in Metabolic Disorder*. New York, Academic Press, vol 3, 1968, pp 49-84.
226. Herberg L, Coleman DL: Laboratory animals exhibiting obesity and diabetes syndrome. *Metabolism* 26:59-99, 1977.
227. Stauffacher W, Cameron DP, Renold AE, et al: Spontaneous hyperglycemia and/or obesity in laboratory rodents: an example of the possible usefulness of animal disease models with both genetic and environmental components. *Recent Prog Horm Res* 27:41-95, 1971.
228. Hajärre A: Über das Vorkommen der Amyloiddegeneration bei Tieren. *Acta Pathol Microbiol Scand [Suppl]* 16:132-162, 1933.
229. Dunn TB: Relationship of amyloid infiltrations and renal disease in mice. *J Natl Cancer Inst* 5:17-28, 1944.
230. Page DL, Glenner GG: Social interaction and wounding in the genesis of spontaneous murine amyloidosis. *Am J Pathol* 67:555-565, 1972.
231. Giles RB Jr, Calkins E: Studies of the composition of secondary amyloid. *J Clin Invest* 34:1476-1482.

- 1955.
232. Dick GF, Leiter L: Some factors in the development of experimental amyloidosis in the rabbit. *Am J Pathol* 17:741-754, 1941.
233. Pirani CL, Bly CG, Sutherland K, et al: Experimental amyloidosis in the guinea pig. *Science* 110:145-146, 1949.
234. Gellhorn A, VanDyke HB, Pyles WJ, et al: Amyloidosis in hamsters with leishmaniasis. *Proc Soc Exp Biol Med* 61:25-30, 1946.
235. Jaffe RH: Amyloidosis produced by injection of proteins. *Arch Pathol* 1:25-36, 1926.
236. Cohen AS, Calkins E, Levene CI: Studies on experimental amyloidosis. I: analysis of histology and staining reactions of casein-induced amyloidosis in the rabbit. *Am J Pathol* 15:971-989, 1959.
237. Glenner GG, Page D, Isersky C, et al: Murine amyloid fibril protein: isolation, purification and characterization. *J Histochem Cytochem* 19:16-28, 1971.
238. Wells HG: *Chemical Pathology*. Philadelphia, WB Saunders, 1925, p 469.
239. Ram JS, DeLellis RA, Glenner GG: Amyloid VIII. Kinetics of murine amyloidosis induced with Freund-type adjuvant. *Int Arch Allergy Appl Immunol* 35:288-297, 1969.
240. Sorenson GD, Heefver WA, Kirkpatrick JB: Experimental amyloidosis. In Bajusz E, Jasnium G (eds): *Methods and Achievements in Experimental Pathology*. Chicago, Year Book Medical Publishers, 1966, vol 1, pp 514-543.
241. Davidson C: Über experimentelle Erzeugung von Amyloid. *Virchows Arch [Pathol Anat]* 150:16-32, 1897.
242. Thung PJ: Senile amyloidosis in mice. *Gerontologia* 1:259-279, 1957.
243. Wright JR, Calkins E, Breen WJ, et al: Relationship of amyloid to aging. Review of the literature and systemic study of 83 patients derived from a general hospital population. *Medicine* 48:39-60, 1969.
244. Cornelius EA: Amyloidosis and renal papillary necrosis in male hybrid mice. *Am J Pathol* 59:317-326, 1970.
245. Barth WF, Willerson JT, Asotky R, et al: Experimental murine amyloid. III. Amyloidosis induced with endotoxins. *Arthritis Rheum* 12:615-626, 1969.
246. Falconer IR: Studies of congenitally goitrous sheep. The iodinated compounds of serum, and circulating thyroid stimulating hormone. *Biochem J* 100:190-196, 1966.
247. Rac R, Pain RW: Congenital goiter in sheep. In Andrews EJ, Ward BC, Altman NH (eds): *Spontaneous Animal Models of Human Disease*. New York, Academic Press, 1979, vol 1, pp 105-108.
248. deVijlder JMM, vanVoorthuizen WF, VanDijk JE, et al: Hereditary congenital goiter with thyroglobulin deficiency in a breed of goats. *Endocrinology* 102:1214-1222, 1978.
249. Rogers MC, Bergstrom WH: Diet-induced hypoparathyroidism. A model for neo-natal tetany. *Pediatrics* 47:207-210, 1971.
250. Weisbrode SE, Capen CC: Model for skeletal resistance to vitamin D in renal failure. *Fed Proc* 35(5):1225-1231, 1976.
251. Argano SAP, Tobin MS, Spain DM: Experimental induction of myelofibrosis with myeloid metaplasia. *Blood* 33:851-858, 1969.
252. Cooper AG, Brown DL: Haemolytic anemia in the rabbit following the injection of human anti-I cold agglutinins. *Clin Exp Immunol* 9:99-110, 1971.
253. Takayama S, Yamada T, Kamata S: Chronic myelogenous leukemia in rats fed 2,7-diacetylamino-fluorene. *Acta Pathol Jpn* 22:309-319, 1972.
254. Morley A, Stohman F Jr: Cyclophosphamide-induced cyclical neutropenia. *New Engl J Med* 282:643-646, 1970.
255. Hermodson MA, Suttie JW, Link KP: Warfarin metabolism and vitamin K requirement in warfarin-resistant rat. *Am J Physiol* 217:1316-1319, 1969.
256. Garner R, Evensen SA: Endotoxin-induced intravascular coagulation and shock in dogs. The role of factor VII. *Br J Haematol* 27:655, 1974.
257. Shwartzman G: *Phenomenon of Local Tissue Reactivity and Its Immunological, Pathological and Clinical Consequences*. New York, Hoeber, 1937, p 461.
258. Wiebe LJ: Small animal models for screening diagnostic radiotracers. In Lambrecht RM, Eckelman WC (eds): *Animal Models for Radiotracer Design*. Berlin, Springer-Verlag, 1983, pp 108-147.
259. Gallagher BM: Monoclonal antibodies: the design of appropriate carrier and evaluation system. In Lambrecht RM, Eckelman WC (eds): *Animal Models of Radiotracer Design*. Berlin, Springer-Verlag, 1983, pp 61-105.
260. Bogden AE, Kelton DE, Cobb WR, et al: A rapid screening method for testing chemotherapeutic agents against human tumor xenografts. In Houchens DP, Ovjera AA (eds): *Proceedings of the Symposium on Use of Athymic (Nude) Mice in Cancer Research*. Stuttgart, Gustav Fischer, 1978, pp 231-250.
261. Bogden AE, Haskell PM, LePage DJ, et al: Growth of human tumor xenografts implanted under the renal capsule of normal immunocompetent mice. *Exp Cell Biol* 47:281-293, 1979.
262. Shah SA, Gallagher BM, Sands H: Radioimmunodetection of small human tumor xenografts in spleen of athymic mice by monoclonal antibodies. *Cancer Res* 45:5824-5829, 1985.
263. Gallagher BM, Sands H, Neary W, et al: Monoclonal antibody localization and imaging of human mammary carcinoma grown at various sites in the nude mice (abstr). *J Nucl Med* 25:P112, 1984.
264. Hosain P, Zeichner SJ, Brody KR, et al: Studies with technetium-99m labeled nucleotide analogs. *Int J Nucl Med Biol* 7:46-49, 1980.
265. Segaloff A, Pettigrew HM: Effect of radiation dose on the synergism between radiation and estrogen in the production of mammary cancer in the rat. *Cancer Res* 38:3445-3452, 1978.
266. Dethlefsen LA, Brown JM, Carrano AV, et al: Can animal and in vitro studies give new, relevant answers to questions concerning mammographic screening for human breast cancer? *J Natl Cancer Inst* 61:1537-1545, 1978.
267. Upton AC, Beebe GW, Brown JM, et al: Report on NCI ad hoc working group on life risks associated with mammography in mass screening for the detection of breast cancer. *J Natl Cancer Inst* 59:479-493, 1977.
268. National Council on Radiation Protection and Measurements (NCRP 66). *Mammography*. Washington DC, NCRP, 1980.
269. Shellabarger CJ, Cronkite EP, Bond VP, et al: Occurrence of mammary tumors in the rat after sublethal whole-body irradiation. *Radiat Res* 6:501-512, 1957.
270. Mettler FA Jr, Hempelmann LH, Dutton AM, et al: Breast neoplasms in women treated with x-rays for acute postpartum mastitis. A pilot study. *J Natl Cancer Inst* 43:803-811, 1969.
271. Mackenzie I: Breast cancer following multiple fluoroscopies. *Br J Cancer* 19:1-8, 1965.
272. Bond VP, Shellabarger CJ, Cronkite EP, et al: Studies on radiation-induced mammary gland neoplasia in the rat V. Induction by localized irradiation. *Radiat Res* 13:318-328, 1960.
273. Shellabarger CJ: Pituitary and steroid hormones in radiation-induced mammary tumors. In Pike MC, Sileri PK, Welsch CW (eds): *Hormones and Breast Cancer*. Banbury Report 8. New York, Cold Spring Harbor Laboratory, 1981, pp 339-351.
274. Mitchell JR, Lozzio BB, Machado E, et al: Metastasizing mammary tumors. Model No. 265. In Capen CC, Hackel DB, Jones TC, Migaki G (eds): *Handbook: Animal Models of Human Disease*, Fascicle 12. Washington DC, Registry of Comparative Pathology, Armed Forces Institute of Pathology, 1983.
275. DeNardo G, Krohn K, DeNardo S, et al: Comparison of oncophylic radiopharmaceuticals in tumor bearing rodents. *J Nucl Med* 17:525, 1976.
276. Oster ZH, Som P, Sacker DF, et al: Time-related (⁶⁷Ga) citrate concentration in tumor and abscess and the effect of desferrioxamine (DFO). *J Nucl Med* 21:214, 1980.
277. Som P, Atkins HL, Bandyopadhyay D, et al: Fluorinated glucose analogue, 2-fluoro-2-deoxy-D-glucose (¹⁸F): non-toxic tracer for rapid tumor detection. *J Nucl Med* 21:670-675, 1980.
278. Wortman J, DeNardo S, DeNardo G, et al: Thrombolytic activity (TA) and fibrinolytic activity (FA) of normal and neoplastic tissue. *J Nucl Med* 17:566-567, 1976.
279. Hall JN, Chen JD, Woolfenders JM, et al: Comparative studies of radiolabeled bleomycin and the ionic radiolabeled species in a bleomycin sensitive tumor model. *J Nucl Med* 17:567, 1976.
280. Friedman AM, Sullivan JC, Ruby SL, et al: Studies of tumor metabolism. I. By use of Mossbauer spectroscopy and autoradiography of (¹⁵³Sm). *Int J Nucl Med Biol* 3:37-40, 1976.
281. Larson SM, Rasey JS, Allen DR: A transferrin mediated uptake of gallium-67 by EMT-6 sarcoma. *J Nucl Med* 19:715-716, 1978.
282. Larson SM, Grunbaum Z, Rasey JS: Positron imaging feasibility studies. I. (³H)-uridine and (¹⁴C)-2-deoxyglucose. *J Nucl Med* 21:P32-33, 1980.
283. Kakinuma J, Kagiya R, Orii H: Chemical properties and tumor affinity of separated isomers of cobalt bleomycin. *Eur J Nucl Med* 5:159-163, 1980.
284. Hammersley PAG, Taylor DM, Cronshaw S: The mechanism of ⁶⁷Ga uptake in animal and human tumors. *Eur J Nucl Med* 5:411-415, 1980.
285. Haynie TP, Konikowski T, Glenn HJ: Technetium-99m stannous citrate brain-tumor uptake in mice: concise communication. *J Nucl Med* 18:915-918, 1977.
286. Konikowski T, Glenn HJ, Haynie TP: Differences in (¹¹¹In) uptake in mouse brain sarcoma based on form of administration. *Int J Nucl Med Biol* 4:13-20, 1977.
287. Welch MJ, Coleman E, Straatman MG, et al: Carbon-11 labeled N-methyl 1,4-diaminobutane: a putrescine analog for prostate and tumor localization. *J Nucl Med* 17:525, 1976.
288. Hudson FR, Dewey D, Galpine AR, et al: Tumor uptake of thallium-201 chloride. *Eur J Nucl Med* 4:283-284, 1979.
289. Volm M, Gericke D, Schuhmacher, et al: Enhancement of incorporation of (¹³¹I)-iododeoxyuridine into tumors after application of *Clostridium ocyotcum* s. *butyricum* (M55). *Eur J Nucl Med* 2:117-120, 1977.
290. Ansari A, Lambrecht RM, Packer S, et al: Note on the distribution of iodine-123 labeled indocyanine green in the eye. XVIII. *Invest Ophthalmol* 14:780-782, 1976.
291. Packer S, Lambrecht RM, Atkins HL, et al: Short-lived radiopharmaceuticals for noncontact detection of ocular melanoma. In Croll M (ed): *Nuclear Ophthalmology*. New York, John Wiley & Sons, 1976, pp 112-121.
292. Bubeck B, Eisenhut M, Heimke U, et al: Melanoma affine radiopharmaceuticals. *Eur J Nucl Med* 6:227-233, 1981.
293. Goodman MM, Elmaleh DR, Merk L, et al: (¹⁸F)-2 and 3-fluorodeoxy-D-glucose as potential diagnostic tracers for tumors. *J Nucl Med* 21:37, 1980.
294. Robbins PJ, Sodd VJ, Scholz KL, et al: Evaluation of antimony-177 for tumor imaging. *Int J Nucl Med Biol* 3:56-57, 1976.
295. Wenzel M, Nipper E, Klose W: Biochemistry of metalocenes I. Distribution of (⁹⁹Fe) or (¹⁰³Ru)-labelled metalocene carboxylic acid in mice. *J Nucl Med* 18:367-372, 1977.
296. Zimmerman M, Schmutz H: Radio diagnosis using (¹²⁵I) fibrinogen and (²⁰³Hg) thymidine. *Eur J Nucl Med* 1:251-254, 1976.
297. Shani J, Wolf M, Schlesinger T: Distribution of 18-F-5-fluorouracil in tumor-bearing mice and rats. *Int J Nucl Med Biol* 5:19-28, 1978.
298. Friedkin M, Fowler J, Gallagher B: 5-(¹⁸F)-fluorouridylylate as a probe for measuring RNA synthesis and tumor growth rates in vivo. *J Nucl Med* 19:702,

- 1978.
299. Wolf W, Shani J, Yong D, et al: Radiopharmacokinetics of antitumor agents: fluorine-18 5-fluorouracil. *J Nucl Med* 18:617, 1977.
300. Anghileri LJ, Heidbreder M: (¹³¹I)deoxyuridine and (¹³¹I)deoxycytidine accumulation by tumors. *Nuklearmedizin* XV:254-255, 1976.
301. Takeda S, Uchida T, Matsuzawa T: A comparative study on lysosomal accumulation of gallium-67 and indium-111 in Morris hepatoma 7316A. *J Nucl Med* 18:835-839, 1977.
302. Hayes RL, Washburn LC, Wieland BW, et al: Carboxyl-labeled (¹¹C)-aminocyclopentane-carboxylic acid, a potential agent for cancer detection. *J Nucl Med* 17:748-751, 1976.
303. Yeh SDJ, Helson L: Studies of tumor localizing radionuclides in transplanted human tumors in nude mice. *J Nucl Med* 19:716, 1978.
304. Pimm MV, Embleton MJ, Perkins AC, et al: In vivo localization of antiosteogenic sarcoma 791T monoclonal antibody in osteogenic sarcoma xenograft. *Int J Cancer* 30:75-85, 1982.

23

Considerations in the Assembly and Submission of the Physician-sponsored Investigational New Drug Application*

Geoffrey Levine and Neil Abel

Any attempt to write a chapter dealing with the Investigational New Drug (IND) process and the design of a clinical trial for a radiopharmaceutical drug, in order for it to move successfully through the IND process without undue delay, cannot be undertaken without the direct acknowledgment and acceptance of the Food and Drug Administration (FDA) guidelines on the subject (1). Because these guidelines (*Guidelines for the Clinical Evaluation of Radiopharmaceutical Drugs*) are so fundamental to the long-term welfare of the nuclear medicine community as well as of the patients it serves, it is highly recommended that all individuals involved with the clinical evaluation of radiopharmaceuticals familiarize themselves with the contents of this document. The guidelines are clear and relatively comprehensive in delineating expectations; it is the interpretation of these guidelines in specific circumstances, however, which needs clarification, and it is to these specific circumstances that we address ourselves later in this chapter.

There are those who would argue that radiopharmaceuticals are, indeed, different than other classes of drugs and that this has gone unrecognized by the FDA. Examination of the guidelines for the clinical evaluation of radiopharmaceuticals (1) compared to guidelines for the clinical evaluation of nonradioactive drugs (2), however, will quickly reveal that this "dif-

ference" has been acknowledged, although the degree of acknowledgment is subject to controversy (1-4).

The ability to interact successfully with the FDA and other government agencies depends, to a large extent, on understanding both the philosophy and the flow of paper within the process, particularly as these relate to the laws, statutes, and regulations which ultimately govern both the context and content of the process. Dr. Siegel (3, 4), past chairman of the FDA Radiopharmaceutical Drug Advisory Committee, has recently reviewed the process of new drug approval (for radiopharmaceuticals) from the clinician's perspective. He noted that the slow approval of new radiopharmaceuticals arises from deficiencies in the actions of the FDA, radiopharmaceutical manufacturers, and nuclear medicine practitioners alike. In the same article, Dr. Siegel reviewed the historical considerations leading up to FDA jurisdiction in the area of radiopharmaceuticals, noting that the transition from Atomic Energy Commission (AEC) (Nuclear Regulatory Commission (NRC)) control has progressed through the transition phase but has not fully matured. Others have commented on the difficulty in meeting literal compliance with guidelines that seem to "become frozen into regulations" (5).

PARTICIPANTS IN THE PROCESS

Two groups can file an IND application: manufacturers and health practitioners. The commercial manufacturer should have little diffi-

* This work does not necessarily represent the opinion of the FDA.

culty in knowing when or if it should file an IND. The health practitioner, on the other hand, does have some difficulty in deciding if the study he or she has planned (a) requires an IND, (b) falls under the practice of medicine and/or pharmacy, or (c) can be handled by internal (institutional) committees. This chapter, then, focuses on clarifying the role of the sponsor and/or investigator with regard to the IND process. The need for a better understanding is underscored by the observation that new advances in nuclear medicine have, to a large extent, come from hospital- and university-based health practitioners. This is in sharp contrast to traditional pharmaceuticals (3, 4) which have been developed predominantly by pharmaceutical manufacturers. In addition, it should be noted that moving the new agents through the process to commercialization (wide distribution) does not come without significant cost (6, 7).

The filing of an IND application can be compared to the situation in which a student is taking a long subjective type of examination. The student wants to please the teacher by saying what the teacher wants to hear; although the teacher is determined to be flexible but correct and fair. The student, however, must be aware of (by either experience, maturity, know-how, or brilliance) the hidden agenda for the context and content of reasonable flexibility. During the classic exchange between student and teacher over the scoring of an essay question, the student often states, "You know that I am aware of this information already." The teacher replies, "I can only grade what you say; I cannot read between the lines." In reality, the perspective that the teacher obtains having read a hundred essay examinations is quite different from that of the student. Indeed, having read hundreds of IND applications the reviewer can approach a particular application with a broader base of knowledge and/or experience, albeit a sense of conservatism.

Each group (the practitioner-investigators and the FDA reviewers) views the other as the expert. The clinician looks to the FDA, with its massive aggregate of financial resources, its large talent pool to draw on, its infinite non-urgent sense of time, and ultimate veto power,

as the expert. The agency looks to the investigators as the experts. After all, the FDA doesn't have patients, nor does it design the studies. If the FDA personnel designed and developed the drugs, they would then become the experts, but they don't. FDA personnel, to some degree, necessarily view themselves as generalists evaluating the protocols of the specialists, thus acting as editors rather than authors.

CLINICAL TESTING FOR SAFE AND EFFECTIVE DRUGS: AN OVERVIEW OF THE PROCESS

Before 1962, there was no requirement that the FDA be notified that drugs were being tested on humans. The 1962 Kefauver-Harris Amendments to the Federal Food, Drug, and Cosmetic Act greatly strengthened the Government's authority over clinical (human) testing of new drugs. With this new regulatory authority, the FDA has taken steps to:

1. Provide added safeguards for those on whom drugs are tested.
2. Improve reports by drug investigators.
3. Establish investigative procedures to supply substantial scientific evidence that a drug is safe and effective.

First Step

Before a new drug may be tested on humans, the sponsor (usually a pharmaceutical firm, sometimes a physician) must give the FDA the information specified as a "Notice of Claimed Investigational Exemption for a New Drug" (Forms FDA 1571, 1572, and 1573) known as an "IND." Copies of these IND forms may be obtained from

Forms Warehouse
Food and Drug Administration
12100 Park Lawn Dr.
Rockville, Maryland 20852

(These forms are included with this chapter as Appendices 23.1, 23.2, and 23.3.)

The IND should include the following information:

- (a) Complete composition of the drug, its source, and manufacturing data, to show

that there are appropriate standards to insure its safe use.

- (b) Results of all preclinical investigations including animal studies. Initially, these should be directed toward defining the drug's safety rather than its efficacy. The data must demonstrate that there will not be unreasonable hazard in initiating studies in humans. Further animal studies may be conducted concurrently with clinical studies. The Bureau of Drugs (now the Center for Drugs and Biologics) will, on request, comment on the adequacy of the proposed animal studies. The FDA generally requires, as a minimum, that (i) there be a pharmacological profile, (ii) acute toxicity be determined in several species of animals and the route of administration be that which will be used in the animal trials, (iii) there be short-term studies ranging from 2 weeks to 3 months, depending on the proposed use, to evaluate toxicity. Additional animal studies frequently are necessary.
- (c) A detailed outline (protocol) of the planned investigation.
- (d) Information regarding the training and experience of the investigators. Investigators are responsible for, and required to submit to the sponsor (not the FDA), either Form FDA 1572 for clinical pharmacology or Form FDA 1573 for clinical trials.
- (e) Copies of all informational material supplied to each investigator. (The type of information is listed in Form FDA 1571.)
- (f) An agreement from the sponsor to notify the FDA and all investigators if any adverse effects arise during either animal or human tests.
- (g) The investigator's agreement to obtain the consent of the person on whom the drug is to be tested before the test is carried out.
- (h) Agreement to submit annual progress reports and commitments regarding disposal of the drug when studies are discontinued.

Physician-sponsored IND

When an investigator wishes to act as sponsor for the use of a drug solely as a research tool or for early clinical investigation of a drug of ther-

apeutic or diagnostic potential (clinical pharmacology Phases I and II), a simpler abbreviated form of submission is acceptable. An example would be the study of a drug that no manufacturer is interested in sponsoring. An outline of such a study should provide the following information:

1. The identity of the compound or compounds together with facts that satisfy the investigator that the agent may be justifiably administered to a human as intended.
2. The purpose of the use and the general protocol.
3. Appropriate background information including a brief statement of the investigator's scientific training and experience and the nature of the facilities available to him. The physician sponsoring this type of IND deals directly with the FDA. The FDA has no authority over the practice of medicine and cannot require a physician to prescribe or not to prescribe a drug for a particular illness. Physicians are encouraged to submit an IND, however, when they use a drug for purposes other than those approved by the FDA. This enables the FDA to accumulate data on the safety and efficacy of the drug for that kind of treatment and to share this information with other physicians (8).

If the sponsor does not perform the manufacturing and control operations for the new drug substance or final dosage form himself, this information (which is required by parts 1 through 5 of the Notice as found on Form FDA 1571) can be furnished on behalf of the sponsor by the supplier who performs these operations. Similarly, a supplier may provide the preclinical or clinical study data. The sponsor may forward such supporting information or arrange to have it transmitted directly to the FDA. In practice, the manufacturer usually maintains a Drug Master File (DMF) containing manufacturing information with the FDA and, on the request of an investigator or sponsor, appends this information to the IND application. The sponsor rarely, if ever, reviews the contents of the DMF under these circumstances. It remains his or her responsibility, however, to see that the items in the DMF meet the requirements.

Clinical Investigation

The kind and the extent of the investigational drug tests are crucial for producing the substantial scientific evidence of safety and effectiveness needed to approve the drug for marketing. This evidence is obtained in three phases.

Phase I

Pharmacology studies are used to determine toxicity, metabolism, absorption and elimination, and other pharmacological actions, preferred route of administration, and safe dosage range. These studies involve a small number of persons and are conducted under carefully controlled circumstances by persons trained in clinical pharmacology.

Phase II

Initial trials are conducted on a limited number of patients for a specific disease treatment or prevention. Additional pharmacological studies performed concurrently on animals may be necessary to indicate safety.

Phase III

Proposals for Phase III of the clinical investigation, which involves extensive clinical trials, are in order if the information obtained in the first two phases demonstrates reasonable assurance of safety and effectiveness or suggests that the drug may have a potential value outweighing possible hazards. The Phase III studies are intended to assess the drug's safety, effectiveness, and most desirable dosage in the treatment of a specific disease in a large group of subjects. The studies, no matter how extensive, should be carefully monitored.

The FDA continually receives reports on the progress of each phase. If the continuation of the studies appears to present an unwarranted hazard to the patients, the sponsor may be requested to modify or discontinue clinical testing until further preclinical work has been completed (8).

In Figure 23.1, one can schematically examine the overall new drug development process. In Figure 23.2, the development and regulation

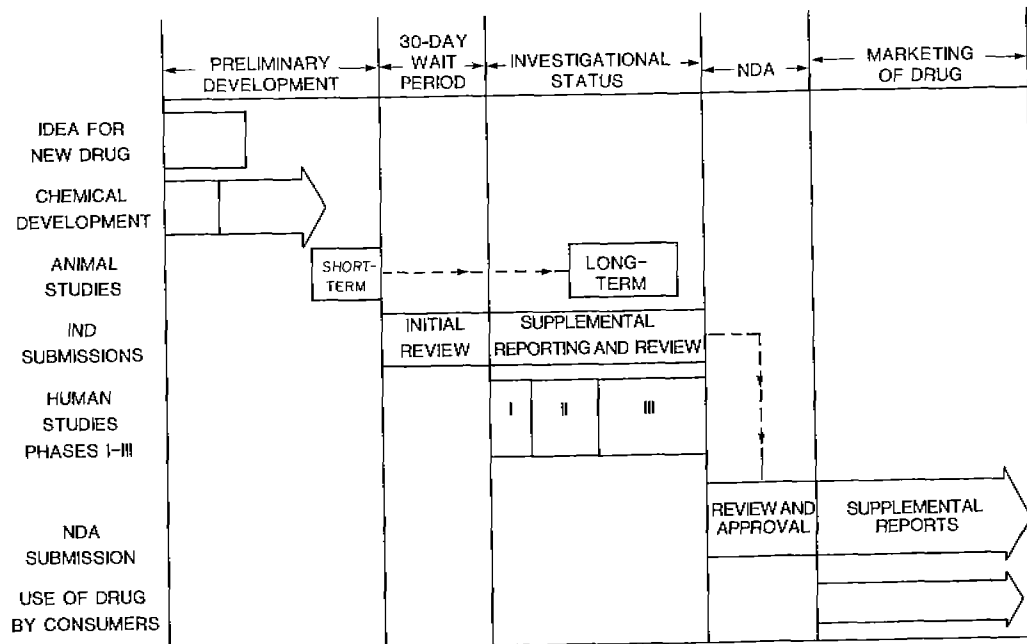

Figure 23.1. Schematic of new drug development process.

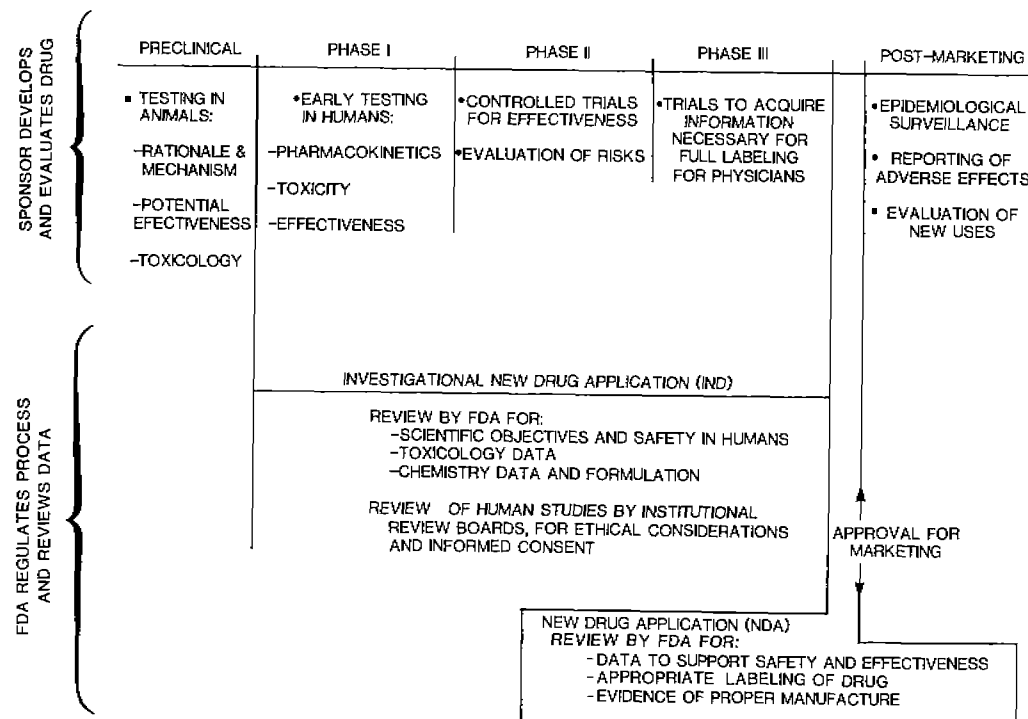

Figure 23.2. Schematic showing regulatory monitoring of drug development and evaluation.

of drugs, including radiopharmaceuticals, are further described.

INSTRUCTIONS FOR SUBMITTING AN IND APPLICATION (FORM FDA 1571)

The submission of an IND application by an individual healthcare practitioner can be a relatively painless exercise or can be one fraught with futility. It should come as no surprise that the task would be relatively more difficult if one tried to fill out the application without a set of instructions. Instructions for the submission of Form FDA 1571 by an individual physician investigator are, in fact, available from the FDA on written request (9). Yet, we have reviewed or assisted in the preparation of IND applications on numerous occasions in which the instructions were never consulted. The most difficult task in the preparation of an IND application is to make sure that it is complete and understandable to all parties concerned; one should not

hesitate to believe that the preparation of an IND is an exercise in "word engineering."

FRAMEWORK AND CRITERIA FOR REVIEW OF AN IND APPLICATION

Knowledge of the framework and criteria used by the reviewer can be of help in the successful completion of the application. A reading of the IND portion of the Bureau of Drugs Guide BD 4831.1, IND/NDA Medical Review Guidelines (10) (Appendix 23.4), offers a rare insight into the position which will be taken by the reviewer in evaluating the IND application. In answering the individual questions of the Form FDA 1571, referring to the IND Medical Review Guidelines will give the investigator the opportunity to discover the type of response which is appropriate. Additionally, answering the questions in a way which both parties (investigator and reviewer) deem appropriate will forestall unnecessary time delays and

thus could lead to more rapid approvals. This is not to say that there might not be differences of opinion and/or of interpretation. Also, the guidelines are just that, and the reviewer will often choose other criteria in addition to those stated based on his or her experience in reviewing a specific type of agent.

AREAS OF THE INDIVIDUAL (PHYSICIAN)-SPONSORED IND WHICH FREQUENTLY CAUSE PROBLEMS

Certain portions of the individual-sponsored IND application for radiopharmaceuticals are repeatedly found to be inadequate or incomplete in their coverage of the specific topic. These areas are listed below, occasionally with editorial comment.

1. The objective and duration of the study should be stated as explicitly and concisely as possible. It must be remembered that the reviewer may not have the same technical or medical background as the investigator and that the reviewer's reasoning will be inductive rather than deductive. Thus, it would probably serve both parties better if the investigator leaned toward "spoon feeding" his or her information rather than overwhelming the reviewer with his or her medical or technical brilliance and verbiage.

2. Acute and subacute toxicity testing must be carried out on animals before the drug can be used in humans. For example, consider ^{99m}Tc -tetracycline. If it has been shown that the tetracycline is safe and effective, it must be shown that the presence of the technetium does not alter the tetracycline so that it will adversely affect the study or be a molecule of sufficient difference to have an adverse toxicity of its own. The point to be made here is that one cannot simply reason it out; the experiments to demonstrate what you are trying to prove must have been carried out.

Additionally, one must choose an appropriate animal model. Testing of the iminodiacetic acid agents in an animal that does not have a gallbladder would be useless. The FDA will review data obtained from other countries in evaluating the safety and effectiveness of a drug. Foreign

data must meet the same requirements as data obtained in the United States.

3. The criteria for patient selection must be explicitly stated. The criteria for patient selection depend on what one is trying to prove. For example, suppose one is trying to show the effectiveness of ^{111}In -labeled leukocytes in a patient with an abscess. The existence of the abscess must be shown by another modality, i.e., biopsy, ultrasound, etc. Thus, if you haven't shown the existence of the disease, you haven't proved anything.

One of the major difficulties with individual (physician)-sponsored clinical trials is that drug regimens and assumptions are not always listed. One would like to minimize the interfering factors that tend to cloud the endpoint of a study. Two examples, in terms of patient selection, might be pregnancy and children.

4. The populations of the patients must be of equal quality. For example, if ^{111}In -labeled leukocytes are being tested on two groups of patients with abscess and one of the groups is predominantly on antibiotic therapy, the groups are not equal. In another example, first-year, healthy medical students earning a few dollars while undergoing esophageal transit studies with ^{99m}Tc -labeled scrambled eggs may not be representative of the general population.

5. When filing an IND application, the investigator or sponsor must be in compliance with his or her own local or state regulations in addition to the federal regulations. Each state or district has its own Board of Medicine or Pharmacy. Each investigator or sponsor must insure that he or she is complying with those regulations. A state may or may not have regulations dealing with investigational drugs, however, and will defer to the FDA for responsibility. California is an example of a state having its own regulations that deal with investigational drugs.

6. Sufficient medical and occupational histories should be obtained so that adequate interpretation of the study can be made. Would not the interpretation of a stress fracture study with ^{99m}Tc -methylene diphosphonate (MDP) vary between a ballerina, college football lineman, marathon runner, secretary, and chemist?

7. Often the point that the investigator is trying to prove is too difficult to prove. As a

result, the drug languishes and doesn't get approved. It is far easier to demonstrate that a drug images a particular organ than it is to prove that a drug can be used for the detection of some disease. Often, with regard to the company-sponsored IND, too broad of an objective is sought (there is difficulty in finding adequate controls). In this situation, "coming in" with an objective that can be easily measured and then amending the objectives for use at a later date should be considered.

8. The sample size must be sufficient to show a difference between two study groups. What size is this? There is no numerical answer that applies in every case, because a sufficient sample size depends on what you are studying, the frequency with which it occurs, the population size, resources, etc. The "bottom line" is that a statistically valid number of patients must be used so that enough good values remain after the study is completed. For example, in the study of an arthritis drug on geriatric patients, 30 normally would not be an unreasonable number, whereas in the study of cyclosporine therapy following heart-lung transplantation in children, 3 might be an unreasonable number at one institution. The important consideration is a statistically valid sample size for the statistical design chosen.

There are scores of study designs to be followed, although the determination of sensitivity and specificity is used quite often. Furthermore, the use of a scale (+1 to +4), compared with a carefully chosen standard, is quite common (e.g., for comparing radiotracer uptake in organ systems or areas of pathology). The criteria for each designation must be clearly identified so that the clinician and reviewer can understand one another.

9. The calculation of radiation dose (e.g., rad/mCi, mGy/MBq) is of equal value whether calculated by the investigator, the Radiopharmaceutical Internal Dose Information Center at Oak Ridge, or by reference to a journal article or package insert. The investigator must show that he understands the meaning of these values.

The total radiation dose that each clinical study volunteer will receive must be included in the submission; this takes into account not only the dose from the investigational drug but also

any dose received from other modalities or agents which are part of the study protocol as well.

Often omitted are the changes in radiopharmaceutical distribution that result in subsequent changes in dosimetry (e.g., due to differences that arise in specific subpopulations or changes that occur in patients receiving adjunct therapy. For example, if ^{99m}Tc -labeled sulfur colloid is to be administered to patients suspected of having liver metastases, it can be reasoned (and shown) that there would be an expected shift of the radiolabeled sulfur colloid to the spleen. Likewise, if the thyroid is blocked with Lugol's solution prior to the administration of an ^{131}I -labeled monoclonal antibody, one could anticipate a shift of free iodide in the agent from the thyroid to other organs.

10. The sponsor of an IND can be anyone (e.g., physician, scientist, pharmacist, corporate executive, etc.). In any study or phase of a study involving patients, although anyone can be an investigator, a physician must be, at least, co-investigator, since in the event of an adverse reaction or similar circumstance a physician is best qualified to treat the patient. If a particular study involves only trials in animals, however, the investigator may be a clinical pharmacologist, nuclear pharmacist, or other qualified individual.

Other than the evaluation of *new* radiopharmaceuticals, a number of areas of clinical investigation could be examined by nuclear medicine professionals. These include investigations that (a) prove new indications for existing radiopharmaceuticals, even if by citizen petition, (b) define new routes of administration for existing radiopharmaceutical agents, (c) describe new dosage forms, and (d) evaluate new salts of existing active agents.

11. The design of a study with a diagnostic radiopharmaceutical can take on numerous forms. For instance, a crossover study is not always required in order to obtain an IND. What is required, however, is a clearly defined objective, a clearly defined rationale, and a clearly defined endpoint. For example, an appropriate double-blind crossover study might include ^{111}In -labeled leukocytes and ^{67}Ga gallium citrate for abscess localization. Nonetheless, one

can obtain valuable information in a study with either ^{111}In -labeled leukocytes or ^{67}Ga -citrate¹ when the same patient has been scanned off and on (or on and off) antibiotics.

With a therapeutic radiopharmaceutical, it may be inappropriate, unethical, or legally risky to deny a patient the benefit of a worthwhile treatment. Thus, prior knowledge obtained from early studies becomes more important with time. One can compare the findings from a new drug, retrospectively, with findings from a similar previous population of patients (e.g., oncology patients). Attempting to carry out a double-blind study with a drug such as cyclosporine, which is used to inhibit transplant organ rejection, could prove legally and therapeutically embarrassing while denying a patient the benefit of treatment.

12. Any attempt to discuss the importance of the appropriate design of a clinical trial in this chapter, other than in a consciousness-raising format, would fall terribly short. Robert Temple, M.D., Director of the FDA Office of Drug Research and Evaluation (formerly the Office of New Drug Evaluation), has brilliantly reviewed the common mistakes, errors in design, and misinterpretations frequently made in the design of clinical trials (11). In this article, he has cited several problem areas in design and proposed design solutions and has suggested a number of aspects of design evaluation that could be improved with little or no increase in development time or cost. Temple describes the difficulties as falling into two broad categories (11):

"1. Individual studies may be designed without careful consideration to the questions they really are capable of answering. The result is either a) a useless trial that answers no questions at all, or b) a trial that answers some other question, not the one intended, or only part of the intended question.

2. The total package of studies may be designed without thoughtful consideration of all the questions that are pertinent. There are, of course, practical limitations on the number of

studies that can reasonably be expected; nevertheless, it seems possible that more of the pertinent questions can be answered without any increase in the total number of patients exposed to clinical trials."

One example, of the many he discussed, involves the comparison of a new drug to a positive control (not a placebo) by showing it is similar to a positive control. The logic is revealing if not often unrecognized.

Suppose one is comparing ^{111}In -labeled leukocytes with ^{67}Ga -citrate in a patient with a particular infection. Showing that both drugs produce similar scans or are equivalent in a study does not demonstrate that either is effective, since the presence of infection must be demonstrated by some other modality. It does show, however, that both are effective or that neither were effective. Because the positive control is known to be effective, we usually conclude that both agents are effective if equivalence is shown. A crucial assumption underlies the conclusion, however, viz., that the effective drug was effective in the particular study in question; this conclusion may not be valid. The error in reasoning would be just as appropriate in comparing two bone agents or two liver agents, etc.

INSURANCE AGAINST UNNECESSARY DELAYS: TIPS FOR SPONSORS OF IND APPLICATIONS

A number of simplistic, common sense, administrative problems immediately evident to the reviewer can, if not handled properly, result in unnecessary delays. Paying close attention to detail and to instructions for filling out the IND application is important. These obvious oversights are mentioned here because they occur so often. Information about how the IND is processed inside the FDA is presented to aid the sponsor and/or investigator.

1. The IND application (Form FDA 1571) must be signed.

2. The application must be submitted in triplicate. Many of the applications are held up for this reason. INDs are initially sent to a Central Record Room where they are given a number as they are received (INDs are not numbered by

category). The IND is then reviewed by three disciplines (pharmacology, chemistry, clinical medicine) and others as required.

3. On receipt, the FDA has 30 days to evaluate the IND for safety (safety only, not effectiveness). It is valuable to send the IND by certified or registered mail so that you have proof that the IND was received in order to validate the 30-day safety period. An acknowledgment letter of receipt should be sent by the FDA. The sponsor will be notified of a "hold" and the reason for it if the IND is held up because of a question concerning safety. Any of the disciplines can recommend a "hold," but the Director of the Division of Oncology and Radiopharmaceuticals makes the final decision to initiate a "holding" action.

It is an interesting marriage in that radiopharmaceuticals, perhaps the most benign category of "drugs," are lumped together (in the same reviewing division of the FDA) with chemotherapeutic drugs, perhaps the most toxic of drugs (Fig. 23.3).

4. Be sure to answer each question and do so in the proper sequence. It is a tedious job to search through piles of paper to find the answer to a question.

5. If the IND document contains many pages, paginate.

6. Recognize that IND applications are of two major types: (a) commercially sponsored INDs, in which a large population will be put at risk, and (b) individually sponsored INDs, in which a small population will be placed at risk.

The IND will address two primary situations: (a) one in which the drug has already been approved, perhaps for another indication, and (b) one in which there is a new clinical entity, i.e., a new drug. In the former situation, the safety may have already been established and the literature can be cited. A photocopy of a few articles attached to the back of the IND as an appendix aids the process. If nothing else, it saves duplicate trips to the library.

7. When calculations of dosimetry are included, (a) "walk" the reviewer through the calculations, since he or she cannot make assumptions, and (b) include the total radiation dose to the patient from all modalities. Thus, if a pulmonary infection is detected by ^{67}Ga -cit-

rate and is confirmed by a chest x-ray, the chest x-ray becomes part of the total dose for the purpose of the proposed study.

8. The curriculum vitae (CV) of the primary investigator and co-investigators (if any) is used to ascertain whether their training in the handling and administration of radioactive drugs is adequate. The CV of the person(s) preparing the radiopharmaceutical is also important (pharmacist, technologist). The IND application must state whether the preparation of the radiopharmaceutical will be under the supervision of a physician (practice of medicine or pharmacy) or be prepared by a drug manufacturing firm (and thus be regulated by Good Manufacturing Practices).

9. Title 21 Code of Federal Regulations (CFR) 50.25 requires that informed consent be obtained. The sponsor of the IND need only say that informed consent will be obtained. A copy of the informed consent need not be submitted with the application. However, reviewers can be quite helpful in pointing out deficiencies in the investigator-prepared informed consent forms—this being clearly to the investigator's advantage. The Institutional Review Board (IRB) is the body that officially approves the informed consent document and/or statement.

10. The IRB is *not* the Radiation Safety Committee (RSC) and is *not* the Radioactive Drug Research Committee (RDRC) and should not be confused with these other committees (12).

11. The 30-day safety period can be waived on request, i.e., on an IND application for an already-approved drug (because there would probably be no safety problem).

When an IND is filed for what is really the practice of medicine and pharmacy, the FDA doesn't really find it necessary to review the study, nor does it want to. It will do so as a courtesy at the present time, however.

12. The IND process is continually under review. A rewrite of IND regulations, which will apply mostly to commercial sponsors, is currently in progress.

13. There are no FDA-required limits on dosage. Each case is examined on its own merit, but consider the following when submitting an IND: Is the risk to be taken worthwhile for the

¹ Although [^{67}Ga]gallium citrate is preferred by IUPAC, ^{67}Ga -citrate is standard, and both are used throughout this chapter.

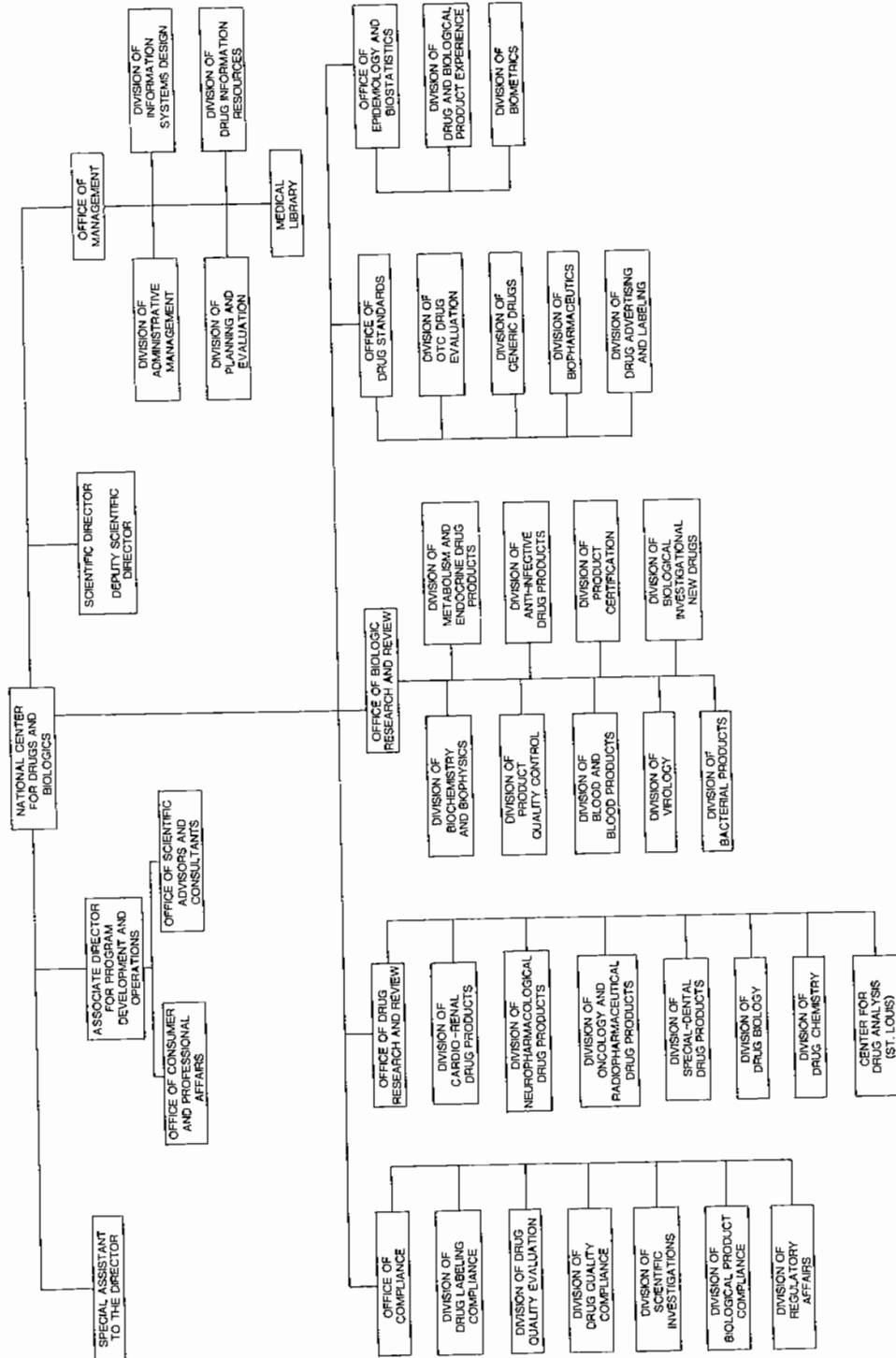

Figure 23.3. Organizational chart for National Center for Drugs and Biologics.

information to be gained? Does the patient benefit or will the information more likely be of benefit to mankind?

Is an IND required in any of the above situations?

Answer: Probably not.

EXAMPLES OF WHEN AN IND IS (AND IS NOT) REQUIRED

Under what circumstances is it necessary to submit an IND, and under what circumstances is the care of the patient (or a patient population) considered to be the practice of medicine and pharmacy? The following examples should help to clarify these often-asked, albeit confusing, questions.

Is an informed consent required?

Answer: Not from the federal (FDA) point of view. If an IND is not required, an informed consent is not required. An individual hospital or individual IRB, however, may have more stringent requirements.

Is it necessary to have the approval of the Radioactive Drug Research Committee (RDRC), if there is one?

Answer: No

Example 1. A university hospital-based investigator (physician) wishes to use ⁶⁴Cu as cupric chloride to evaluate whether or not a patient who is scheduled to undergo a liver transplant has Wilson's disease.

Comment. The United States literature reports the use of ⁶⁴Cu. It is not on the NRC Section 10 CFR Part 35 list of approved radionuclides, however. The study has not been used for years (at least since the 1960s), except in a relatively small number of patients, because of the relatively small number of individuals with this disease. [⁶⁴Cu]cupric chloride is purchased as a nonsterile radiochemical. There is no Drug Master File (DMF).

What if one is evaluating the effect (i.e., the degree of improvement) of a liver transplant on patients with Wilson's disease, compared with the effect of British antilewisite (BAL) on patients not undergoing transplants? Is an IND required prior to the administration of ⁶⁴Cu?

Answer: Yes, an IND application would have to be filed.

Is the preparation and use of this isotope considered the practice of medicine and pharmacy? Answer: Yes

This apparently is a bona fide research study in which the findings from two groups are compared. The patient has no choice as to which group he or she is entered into.

What if the patient is at another hospital and is covered by the same NRC license, the same Radiation Safety Committee, but a different IRB?

Answer: This falls under the practice of medicine and pharmacy.

Example 2. A university hospital-based physician who had submitted Form FDA 1571 for the use of ^{99m}Tc-labeled antimony sulfide colloid (ASC) in the management of patients with melanoma has received FDA approval. He moves to another university hospital where ^{99m}Tc-ASC is requested for use in the management of patients with melanoma undergoing three treatment protocols. Other investigators at the new hospital already have approval to use ^{99m}Tc-ASC for internal mammary chain lymphoscintigraphy.

Suppose the patient is a child?

Answer: This falls under the practice of medicine and pharmacy. In each of these situations, the individual care or treatment of the patient may be determined by the results of the test, and the patient will have a choice as to whether or not to receive a treatment plan.

Can the newly arrived physician be called on to perform the ^{99m}Tc-ASC study? If he cannot, how can use of ^{99m}Tc-ASC for patients with melanoma be arranged?

Answer: No, he cannot. The IND may or may not move with the investigator. It would, however, be more advantageous for the investigator who moved to file a new IND and make refer-

ence to his previous IND with regard to the technical and medical content. The IRB at the new institution would be required to grant its approval for use.

It would also be appropriate for the investigators in residence to modify or amend their IND for internal mammary chain lymphoscintigraphy to include melanoma.

A third option is for all of the investigators to file Form FDA 1573 (Statement of Investigator) and become clinical investigators for a sponsor with an active Form FDA 1571 (IND).

Would the diagnostic test with $^{99m}\text{Tc-ASC}$ still be investigational if, as a result of the evaluation of a patient with $^{99m}\text{Tc-ASC}$, the degree of disease became known and the treatment plan was altered?

Answer: No, the use of $^{99m}\text{Tc-ASC}$ would not be investigational but would fall under the practice of medicine and pharmacy.

Example 3. The administration of tritiated water and [^{14}C]urea are requested as an indicator aide in evaluating pulmonary edema and capillary permeability in patients undergoing heart-lung transplants.

Both agents are purchased as radiochemicals. Is there an IND requirement?

Answer: There is no IND requirement for the use of tritiated water or [^{14}C]urea either as part of a research study or in the practice of medicine and pharmacy.

The term radioactive drug as defined in Title 21 CFR 310.3n (13) specifically excludes "... drugs such as carbon containing compounds or potassium containing salts which contain trace quantities of naturally occurring radionuclides. . . ." There are IND requirements for other than radioactive drugs, and these requirements should be met if the product is not endogenous.

A second question that is raised deals with the conversion of a radiochemical to a radiopharmaceutical with the drug's subsequent removal from FDA jurisdiction.

A radiopharmaceutical may be prepared from radiochemicals on a prescription basis under the practice of medicine and pharmacy. Although in

the event of error a criminal penalty can be avoided with such a mechanism, errors of malpractice would still be applicable under civil law on behalf of the patients involved.

Would a Radioactive Drug Research Committee (RDRC) (12) have any role in this process?

Answer: The RDRC has no role whatsoever regarding the use of a radioactive pharmaceutical for patient management. If one was simply looking at the kinetics of a radiolabeled drug for research purposes, the RDRC could conceivably have a role. Nonetheless, an IND would not be required in this situation.

Example 4. A nuclear pharmacist in a department of nuclear medicine wishes to dilute a vial of ^{32}P colloidal chromic phosphate so that the dose can be more accurately measured and dispensed in a larger volume. ^{32}P colloid is prepared in 30% dextrose solution as the diluent. The dose will be used within 2 hours of dispensing.

Is an IND needed?

Answer: The use of an approved drug for the diagnosis or treatment of a specific patient for an approved use (in this case an intracavity administration) falls under the practice of medicine and pharmacy. Thus, an IND is not required.

Can this dilution be prepared by a nuclear medicine technologist or radiopharmaceutical scientist under a physician's supervision?

Answer: Yes, it can.

Does one need to conduct stability studies prior to modifying a specific radiopharmaceutical preparation?

Answer: In general, if the opportunity is present, it is to one's advantage to conduct such studies. Whether or not such studies are required falls within the judgment of pharmacists and pharmaceutical chemists. When there is uncertainty, references in the literature cannot be found, and/or expert advice cannot be satisfactorily gained, it is prudent not to take a chance. Just the changing of a solvent can often alter the dissolution rate of a drug by changing the polar-

ity of the solute-solvent relationship (e.g., oil versus water). Try, for example, to elute a $^{99m}\text{Mo}/^{99m}\text{Tc}$ generator with water or 0.45% saline instead of 0.9% saline. What would happen to the insolubility of ^{32}P colloidal chromic phosphate if the pH was out of specifications? Would soluble ^{32}P diffuse through the cavity wall and result in altered biodistribution and significantly different radiation dosimetry?

Example 5. The nuclear medicine department of a children's hospital wishes to prepare a lung scan dose of ^{99m}Tc -labeled macroaggregated albumin for a 6-month-old infant. Examination of the package insert directions provides no guidance in terms of how to prepare the product for an infant under these circumstances.

Is an IND needed?

Answer: Obviously one does not request a lung scan for an infant without a clear and justifiable need to obtain certain specific information. Not to perform this study could be viewed as an omission by some. Moreover, the FDA has recognized that many times the literature (3, 4) and clinical practice (3, 4) are far ahead of the package insert materials (e.g., approved indications). This example falls under the practice of medicine and is not contrary to existing regulations.

Example 6. A hospital-based physician wishes to administer the renal agent ^{99m}Tc -diethylene-triaminepentaacetic acid (DTPA) by a different route of administration, i.e., as an aerosol for pulmonary imaging.

Is this unapproved use of a radiopharmaceutical allowable?

Answer: On August 31, 1981, the NRC Advisory Committee on the Medical Use of Isotopes discussed the problem of unapproved uses of approved radiopharmaceuticals in which a variance from the labeling with regard to the route of administration is involved. NRC staff members indicated their willingness to review requests for such uses and to approve those judged to result in acceptable radiation exposure to patients (3, 4, 14).

"On February 4, 1983, the NRC promulgated a final rule granting the first exemption to the 'route of administration' restriction. This exemption permits the use of ^{99m}Tc -DTPA as an aerosol for pulmonary imaging. Moreover, this rule establishes a mechanism whereby similar exemptions might be approved by the NRC. . . [(4)]."

Example 9 gives additional information on unapproved uses of approved radiopharmaceuticals.

Example 7. A physician working in cooperation with an immunology laboratory at a university-based health center is a leader in the development of hybridoma technology. A labeled monoclonal antibody which has been thoroughly tested as a diagnostic agent in normal mice, tumor-bearing mice, and human tumor-bearing nude mice is considered for testing in a patient for the first time. The intent is to determine whether the agent will localize in a specific patient's tumor and perhaps even localize in metastases. The university hospital has a Radioactive Drug Research Committee (RDRC).

Can the RDRC at this university-based health center authorize testing in humans in this case?

Answer: On May 6, 1983, the FDA Radiopharmaceutical Drug Advisory Committee reviewed Section 21 CFR 361.1, regulations that had been promulgated 8 years earlier and in which the responsibilities of the RDRC had been set forth. One topic of discussion centered about the question of new chemical entities as drug products for human use, with approval handled by the RDRC. The current regulations state that if the radiopharmaceutical drug product is a radionuclide attached to an established drug for which the physiological use in humans is known and the dose administered in the tracer study is below the physiologic dose, the Committee has the authority to approve of its use.

If, however, the radiopharmaceutical is a new chemical entity for which the pharmacologic dose in humans is not known, animal data cannot be used to establish the fact that there is no human pharmacological effect.

Thus under current regulations, since a monoclonal antibody is a new chemical or a biological entity, the RDRC would not be able to authorize testing in humans and an IND would have to be filed. In practice, however, the RDRC can play a valuable oversight role.

Can information obtained in an RDRC study be used to provide information that will be used to treat a patient?

Answer: Yes, it can.

Suppose that in this first patient to be studied the findings would have an impact on the course of treatment. Would this be considered the practice of medicine?

Answer: This process would, in effect, be skipping over the intent of a Phase I IND study which is carried out, in part, to demonstrate safety. Phases II and III of the IND process represent the clinical trial. The RDRC cannot approve the use of any drug that is part of a clinical trial. The clinical trial is approved by the IRB.

Comment. There has been talk that should the role of the RDRC be expanded to approve new entities, the composition of the Committee likely would be changed to include pharmacologists and toxicologists (14). Advantages of such a change might include (a) the preliminary testing of the new drug entity in a very small number of humans prior to the submission of an IND, (b) speeding up the research process, since in-house communication could be faster than communication with the FDA, and (c) possibly less information required by the RDRC than would be submitted in an IND.

A subcommittee of the FDA Radiopharmaceutical Drug Advisory Committee chaired by H. William Strauss has been appointed to examine whether or not the role of the RDRC should be expanded to include the responsibility of permitting the investigation of new chemical entities (14). This subcommittee could recommend that the Radiopharmaceutical Drug Advisory Committee propose a change in the regulations which would allow for the expanded role. Nonetheless, it is up to the FDA to approve of the expanded role. It is exactly this particular impasse which represents the crux of

the diversity of interests between clinicians and the FDA.

Human nature dictates that the members of organizations (the FDA or the "organization of individual practitioners") defend the vested interests of that organization or society. Each group has a mission to accomplish. Because neither (protection of the public health nor care of the individual patient) is mutually exclusive, there usually is room and flexibility to find a mutually acceptable solution. The continuous striving for mutually acceptable solutions, however, will require tenacity and goodwill if the development of safe and effective radioactive agents are to reach patients in the shortest possible time.

Example 8. A university-based physician wishes to begin studies on the possible formation of deep vein thrombosis (DVT) following the use of a surgical cuff. For this purpose the controls will be the contralateral leg for one group of patients, and, for the second group, randomized surgical patients with and without the cuff. The patients will not benefit from the study unless the presence of DVT is discovered and found to be necessary to treat. Since ^{125}I -labeled fibrinogen is unsuitable for imaging, the agent of choice might be ^{131}I -labeled fibrinogen or ^{111}In -labeled platelets. Assume that ^{131}I -labeled fibrinogen is selected as the agent for this study.

Is the study investigational? After all, surgical cuffs are used routinely anyway.

Answer: Yes, this is a bona fide study in which patients are randomly entered.

Does one need to file an IND, since ^{131}I -labeled fibrinogen has been reported to be used for this purpose in the literature? Use of ^{131}I is merely the substitution of one radioactive substance for another (i.e., for ^{125}I).

Answer: Fibrinogen (labeled with ^{125}I) has been found to be safe and effective for detection (but not imaging, per se) of DVT. If the radionuclide is used in trace quantity, any of several radionuclides could potentially be substituted as the tracer, and the resulting compound could be investigated as an imaging agent. One is cau-

tioned that there are many varieties of fibrinogen, however, and that only the approved type of fibrinogen from an approved lot will be acceptable. The "bottom line" is that if the FDA learned of the use of ^{131}I -fibrinogen as an imaging agent in a research study, it would notify the investigator that an IND was necessary.

Who makes the decision regarding the need for an IND?

Answer: At most institutions, the Radiation Safety Committee authorizes possession of a radioactively labeled drug in a specific chemical form, usually through its human use subcommittee when the material will be used in humans. Additionally, the IRB, also known as the human experimentation committee or a similar name, reviews the project for design and for the establishment of an informed consent document. If the institution has an RDRC, this committee could help make the decision as well. Usually, the nuclear medicine physician makes the initial decision, however.

Could ^{131}I -labeled fibrinogen be prepared and used to image DVT in a single patient?

Answer: Yes, and without filing an IND.

Example 9.

Can an approved radiopharmaceutical administered via one route be administered by another route for an unapproved indication?

Answer: Yes, under certain circumstances. By law, indications can be added to the package inserts when the safe and effective use of that indication has been proven by data submitted for evaluation. If the holder of a radiopharmaceutical NDA does not submit a request for a new indication, the FDA cannot arbitrarily place a new indication into the package insert without adequate data to support the specific indication.

An independent group or even an individual citizen may act to amend the indication of a drug by petition after a thorough search of the literature. The Radiopharmaceutical Drug Advisory Committee usually is involved in the process (3, 4, 14). During 1984, the FDA approved new indications for three widely used

radiopharmaceuticals. The agency approved the use of sodium [$^{99\text{m}}\text{Tc}$]pertechnetate for dacryocystography, $^{99\text{m}}\text{Tc}$ -labeled sulfur colloid for oral administration (e.g., gastrointestinal studies), and ^{133}Xe for intradermal injection. Previously, the FDA had approved NDA supplements which add direct radionuclide cystography to the list of indications for [$^{99\text{m}}\text{Tc}$]-pertechnetate.

Another example which is appropriate for this process is the use of $^{99\text{m}}\text{Tc}$ -MAA to verify hepatic catheter placement for chemotherapy infusion by pump. More than a dozen articles in the literature suggest the safety, efficacy, and appropriateness of this indication. The approval of this indication will, however, depend on the design of the studies and whether or not the data support the conclusions which are reached. Two other radiopharmaceuticals which are appropriate for this process and need to be evaluated are $^{99\text{m}}\text{Tc}$ -DTPA for cisternography and ^{111}In -DTPA for gastrointestinal tract studies.

Example 10. A university-based hospital has filed an IND for the use of ^{111}In -labeled leukocytes to detect sites of infection. One patient presents with a lymphoma in the cheek which is thought to be a site for the trapping of lymphocytes, since the patient is lymphocyte depleted.

How is this situation best handled?

Answer: There are over 400 INDs for leukocytes, and to date, it appears to be safe. Because lymphocytes are part of the leukocyte population, in this case, safety would not be an expected problem.

Since the IND application has been filed, one can simply submit an amendment to the present IND, i.e., a new study protocol for one of the active agents in a previously filed IND. Since this is a drug entity which appears to be safe, is suspected of being effective, and is for the management of a particular patient, however, the nuclear medicine diagnostic study really falls under the practice of medicine and pharmacy such that an IND would not be required. Nonetheless, had one not already had an IND filed for ^{111}In -oxine, one would have considerable difficulty in obtaining ^{111}In -oxine from any of the manufacturers in order to label the lympho-

cytes. (Note: ^{111}In -oxine for labeling autologous leukocytes is now approved by the FDA.)

This brings up the subject of the emergency (compassionate) IND. In those circumstances in which a specific patient requires diagnosis and/or treatment, the 30-day evaluation period can be waived by direct contact (telephone) between the physician and the medical director (or his or her representative) of the FDA. Specific clinical circumstances and justification for the investigational study are required. The compassionate IND process might be appropriate (if the process is not abused) when recognizing the large commitment of time and manpower in the process of preparing the IND application. Certainly, there are many occasions in which the physician investigator simply lacks the forbearance required to go through the lengthy process and settles for what may or may not be a less specific or less sensitive form of diagnosis or treatment.

Example 11. A community-based hospital's departments of nuclear medicine and surgery are conducting a cooperative study to evaluate the effect of a surgical cuff on clot formation in the treated leg, with the contralateral leg used as a control. Patients are randomly placed into groups receiving the surgical cuff, drugs, placebo, or nothing.

Which of the following components represents a recovery of actual costs involved in conducting this study?

- Purchase of ^{125}I -labeled fibrinogen (with a cost of X dollars per kit of five doses).
Note: What would happen if only four doses are used prior to expiration of the kit? Do four people divide the charge for five doses?
- Shipping and delivery charges from the manufacturer.
- Radiopharmacy time for preparation of the dose, including assay, quality control, and dispensing.
- Technologist and hospital fee for conducting the study.
- Physician's component for interpreting the study.

- Secretarial charge for typing patient reports.
- Review and analysis of the entire project by the investigators and the collaborative personnel.
- Ordering, receipt, wipe testing, and other radiation control practices.
- Preparation and review of the informed consent statement. (How do you charge for committee time?)
- Preparation and submission of the IND application, if required.
- Service contracts on the equipment used—lbrinator, dose calibrator, Geiger-Müller counters.
- Indirect costs—heat, light, electricity, administrative staff (accounting, etc.).
- Supplies (syringes, needles, gloves, padding, markers, etc.).
- Contracted decontamination (radiation safety) services, in the event of a spill.

Answer: With regard to *item a*, the charge for the drug, the sponsor would have to obtain permission from the FDA in order to charge the investigator for the investigational drug. In practice, it is unlikely that such permission would be forthcoming, since it does not appear to be proper to charge an investigator for an experimental drug. The same is true for the shipping and delivery charges (*item b*), since these are generally considered part of the radiopharmaceutical drug cost. However, the FDA has no regulations that prevent the physician investigator from charging the patient for the investigational drug or any related services. Likewise, the pharmacist who is compounding or preparing the pharmaceutical can charge the patient for services rendered. In other words, with respect to *items a–n*, the FDA takes no official position as to what the investigator can charge the patient in a clinical study. Since the FDA takes no position in these areas, the bottom line for a charge to a patient is a matter of conscience and appropriateness.

REFERENCES

- Department of Health and Human Services: *Guidelines for the Clinical Evaluation of Radiopharmaceutical Drugs* (revised), HHS (FDA) 81-3120. Washington DC, United States Government Printing Office, 1981.

- Department of Health and Human Services: *General Considerations for the Clinical Evaluation of Drugs*, HHS (FDA) 77-3040. Washington DC, United States Government Printing Office, 1977.
- Siegel BA: Radiopharmaceuticals and FDA: a clinician's perspective. *Med Instrument* 15:355–360, 1981.
- Siegel BA: Radiopharmaceuticals and FDA: a clinician's perspective. *J Nucl Med Technol* 11:177–186, 1983.
- News and Comment: Industry airs grievances over FDA's NDA review process. *Am Pharm* NS23:8, 1983.
- Bennett LR: Where are the costs of radiopharmaceuticals leading us? Editorial. *Appl Radiol* 12:73, 1983.
- Lipton J: The State of Nuclear Medicine: An Industry Perspective. An address given to American College of Nuclear Physicians, September 24, 1983.
- Department of Health and Human Services: *Clinical Testing for Safe and Effective Drugs* (revised), HHS (FDA) 74-3015. Washington DC, United States Government Printing Office, 1981.
- Food and Drug Administration: *Instructions for Submitting Form FDA 1571, A Notice of Claimed Investigational Exemption for a New Drug, by an Individual Physician Investigator (Investigational New Drug Application)*, FDA, Document Control Section HFD-106, New Drug Evaluation. Rockville, MD, Bureau of Drugs, 1982.
- Department of Health and Human Services: *IND Medical Review Guidelines*, Guide BD 4831.1 Attachment A. Washington DC, FDA Internal Document, 1980.
- Temple R: Government viewpoint of clinical trials. *Drug Inform J* 16:10–17, 1982.
- Food and Drug Administration: Part 361—Prescription drugs human use generally recognized as safe and effective and not misbranded; drugs used in research. *Fed Reg* 21:155–160, April 1982.
- Food and Drug Administration: 21 CFR Part 310.3. definition and interpretation. *Fed Reg*, 1983.
- Callahan RJ: Report of the Government Relations Committee. *Radiopharm Sci Council Newslett* 9–10, Fall 1983.

DEPARTMENT OF HEALTH AND HUMAN SERVICES PUBLIC HEALTH SERVICE FOOD AND DRUG ADMINISTRATION	Form Approved; OMB No. 0910-0014 Expiration Date: February 29, 1984.
NOTICE OF CLAIMED INVESTIGATIONAL EXEMPTION FOR A NEW DRUG	NOTE: No drug may be shipped or study initiated unless a complete statement has been received (21 CFR 312.1(a)(2)).

Name of Sponsor _____ Date _____

Address _____ Telephone () _____

Name of Investigational Drug _____

FOR A DRUG:

Food and Drug Administration
 Office of New Drug Evaluation (HFN-106)
 5600 Fishers Lane
 Rockville, Maryland 20857

FOR A BIOLOGIC:

Food and Drug Administration
 Office of Biologics (HFN-823)
 8800 Rockville Pike
 Bethesda, Maryland 20205

Dear Sir:

The sponsor, _____, submits this notice of claimed investigational exemption for a new drug under the provisions of section 505(i) of the Federal Food, Drug, and Cosmetic Act and § 312.1 of Title 21 of the Code of Federal Regulations.

Attached hereto in triplicate are:

1. The best available descriptive name of the drug, including to the extent known the chemical name and structure of any new-drug substance, and a statement of how it is to be administered. (If the drug has only a code name, enough information should be supplied to identify the drug.)
2. Complete list of components of the drug, including any reasonable alternates for inactive components.
3. Complete statement of quantitative composition of drug, including reasonable variations that may be expected during the investigational stage.
4. Description of source and preparation of, any new-drug substances used as components, including the name and address of each supplier or processor, other than the sponsor, or each new-drug substance.
5. A statement of the methods, facilities, and controls used for the manufacturing, processing, and packing of the new drug to establish and maintain appropriate standards of identity, strength, quality, and purity as needed for safety and to give significance to clinical investigations made with the drug.
6. A statement covering all information available to the sponsor derived from preclinical investigations and any clinical studies and experience with the drug as follows:
 - a. Adequate information about the preclinical investigations, including studies made on laboratory animals, on the basis of which the sponsor has concluded that it is reasonably safe to initiate clinical investigations with the drug; Such information should include identification of the person who conducted each investigation; identification and qualifications of the individuals who evaluated the results and concluded that it is reasonably safe to initiate clinical investigations with the drug and a statement of where the investigations were conducted and where the records are available for inspection; and enough details about the investigations to permit scientific review. The preclinical investigations shall not be considered adequate to justify clinical testing unless they give proper attention to the conditions of the proposed clinical testing. When this information, the outline of the plan of clinical pharmacology, or any progress report on the clinical pharmacology, indicates a need for full review of the preclinical data before a clinical trial is undertaken, the Department will notify the sponsor to submit the complete preclinical data and to withhold clinical trials until the review is completed and the sponsor notified. The Food and Drug Administration will be prepared to confer with the sponsor concerning this action.

- b. If the drug has been marketed commercially or investigated (e.g. outside the United States), complete information about such distribution or investigation shall be submitted, along with a complete bibliography of any publications about the drug.
- c. If the drug is a combination of previously investigated or marketed drugs, an adequate summary of preexisting information from preclinical and clinical investigations and experience with its components, including all reports available to the sponsor suggesting side effects, contraindications, and ineffectiveness in use of such components. Such summary should include an adequate bibliography of publications about the components and may incorporate by reference any information concerning such components previously submitted by the sponsor to the Food and Drug Administration. Include a statement of the expected pharmacological effects of the combination.
- d. If the drug is a radioactive drug, sufficient data must be available from animal studies or previous human studies to allow a reasonable calculation of radiation absorbed dose upon administration to a human being.
7. A total (one in each of the three copies of the notice) of all informational material, including label and labeling, which is to be supplied to each investigator. This shall include an accurate description of the prior investigations and experience and their results pertinent to the safety and possible usefulness of the drug under the conditions of the investigation. It shall not represent that the safety or usefulness of the drug has been established for the purposes to be investigated. It shall describe all relevant hazards, contraindications, side-effects, and precautions suggested by prior investigations and experience with the drug under investigation and related drugs for the information of clinical investigators.
8. The scientific training and experience considered appropriate by the sponsor to qualify the investigators as suitable experts to investigate the safety of the drug, bearing in mind what is known about the pharmacological action of the drug and the phase of the investigational program that is to be undertaken.
9. The names and a summary of the training and experience of each investigator and of the individual charged with monitoring the progress of the investigation and evaluating the evidence of safety and effectiveness of the drug as it is received from the investigators, to gether with a statement that the sponsor has obtained from each investigator a completed and signed form, as provided in subparagraph (12) or (13) of this paragraph, and that the investigator is qualified by scientific training and experience as an appropriate expert to under

take the phase of the investigation outlined in section 10 of the "Notice of Claimed Investigational Exemption for a New Drug." (In crucial situations, phase 3 investigators may be added and this form supplemented by rapid communication methods, and the signed Form FD-1573 shall be obtained promptly thereafter.)

10. An outline of any phase or phases of the planned investigations and a description of the institutional review committee, as follows:

- a. Clinical pharmacology. This is ordinarily divided into two phases: Phase 1 starts when the new drug is first introduced into man - only animal and in vitro data are available - with the purpose of determining human toxicity, metabolism, absorption, elimination, and other pharmacological action, preferred route of administration, and safe dosage range; phase 2 covers the initial trials on a limited number of patients for specific disease control or prophylaxis purposes. A general outline of these phases shall be submitted, identifying the investigator or investigators, the hospitals or research facilities where the clinical pharmacology will be undertaken, any expert committees or panels to be utilized, the maximum number of subjects to be involved, and the estimated duration of these early phases of investigation. Modification of the experimental design on the basis of experience gained need be reported only in the progress reports on these early phases, or in the development of the plan for the clinical trial, phase 3. The first two phases may overlap and, when indicated, may require additional animal data before these phases can be completed or phase can be undertaken. Such animal tests shall be designed to take into account the expected duration of administration of the drug to human beings, the age groups and physical status, as for example, infants, pregnant women, premenopausal women, of those human beings to whom the drug may be administered, unless this has already been done in the original animal studies. If a drug is a radioactive drug, the clinical pharmacology phase must include studies which will obtain sufficient data for dosimetry calculations. These studies should evaluate the excretion, whole body retention, and organ distribution of the radioactive material.
- b. Clinical trial. This phase 3 provides the assessment of the drug's safety and effectiveness and optimum dosage schedules in the diagnosis, treatment, or prophylaxis of groups of subjects involving a given disease or condition. A reasonable protocol is developed on the basis of the facts accumulated in the earlier phases, including completed and submitted animal studies. This phase is conducted by separate groups following the same protocol (with reasonable variations and alternatives permitted by the plan) to produce well-controlled clinical data. For this phase, the following data shall be submitted:
 - i. The names and addresses of the investigators. (Additional investigators may be added.)
 - ii. The specific nature of the investigations to be conducted, to gether with information or case report forms to show the scope and detail of the planned clinical observations and the clinical laboratory tests to be made and reported.
 - iii. The approximate number of subjects (a reasonable range of subjects is permissible and additions may be made), and criteria proposed for subject selection by age, sex, and condition.
 - iv. The estimated duration of the clinical trial and the intervals, not exceeding 1 year, at which progress reports showing the results of the investigations will be submitted to the Food and Drug Administration.
- c. Institutional review board (IRB). The sponsor must give assurance that an IRB that complies with the requirements set forth in Part 56 of this chapter will be responsible for the initial and continuing

review and approval of the proposed clinical study. The sponsor must also provide assurance that the investigators will report to the IRB all changes in the research activity and all unanticipated problems involving risks to human subjects or others, and that the investigators will not make any changes in the research without IRB approval, except where necessary to eliminate apparent immediate hazard to the human subjects. FDA will regard the signing of the Form FDA 1571 as providing the necessary assurances above.

(The notice of claimed investigational exemption may be limited to any one or more phases, provided the outline of the additional phase or phases is submitted before such additional phases begin. A limitation on an exemption does not preclude continuing a subject on the drug from phase 2 to phase 3 without interruption while the plan for phase 3 is being developed.)

Ordinarily, a plan for clinical trial will not be regarded as reasonable unless, among other things, it provides for more than one independent competent investigator to maintain adequate case histories of an adequate number of subjects, designed to record observations and permit evaluation of any and all discernible effects attributable to the drug in each individual treated, and comparable records on any individuals employed as controls. These records shall be individual records for each subject maintained to include adequate information pertaining to each, including age, sex, conditions treated, dosage, frequency of administration of the drug, results of all relevant clinical observations and laboratory examinations made, adequate information concerning any other treatment given and a full statement of any adverse effects and useful results observed, together with an opinion as to whether such effects or results are attributable to the drug under investigation.

11. A statement that the sponsor will notify the Food and Drug Administration if the investigation is discontinued, and the reason therefor.

12. A statement that the sponsor will notify each investigator if a new-drug application is approved, or if the investigation is discontinued.

13. If the drug is to be sold, a full explanation why sale is required and should not be regarded as the commercialization of a new drug for which an application is not approved.

14. A statement that the sponsor assures that clinical studies in humans will not be initiated prior to 30 days after the date of receipt of the notice by the Food and Drug Administration and that he will continue to withhold or to restrict clinical studies if requested to do so by the Food and Drug Administration prior to the expiration of such 30 days. If such request is made, the sponsor will be provided specific information as to the deficiencies and will be afforded a conference on request. The 30 day delay may be waived by the Food and Drug Administration upon a showing of good reason for such waiver; and for investigations subject to institutional review committee approval as described in item 10c above, and additional statement assuring that the investigation will not be initiated prior to approval of the study by such committee.

15. When requested by the agency, an environmental impact analysis report pursuant to § 25.1 of this chapter.

16. A statement that all nonclinical laboratory studies have been, or will be, conducted in compliance with the good laboratory practice regulations set forth in Part 58 of this chapter, or, if such studies have not been conducted in compliance with such regulations, a statement that describes in detail all differences between the practices used in conducting the study and those required in the regulations.

Very truly yours,

SPONSOR	PER
	INDICATE AUTHORITY

(This notice may be amended or supplemented from time to time on the basis of the experience gained with the new drug. Progress reports may be used to update the notice.)

ALL NOTICES AND CORRESPONDENCE SHOULD BE SUBMITTED IN TRIPLICATE.

DEPARTMENT OF HEALTH AND HUMAN SERVICES PUBLIC HEALTH SERVICE FOOD AND DRUG ADMINISTRATION	Form Approved; OMB No. 0910-0015 Expiration Date: December 31, 1984.
STATEMENT OF INVESTIGATOR (Clinical Pharmacology)	
NOTE: No drug may be shipped or study initiated unless a completed statement has been received (21 CFR 312.1(a)(12))	
TO: SUPPLIER OF THE DRUG (Name and address, include ZIP Code)	NAME OF INVESTIGATOR (Print or Type) _____ DATE _____ NAME OF DRUG _____
Dear Sir: The undersigned, _____ submits this statement as required by section 505(i) of the Federal Food, Drug, and Cosmetic Act and § 312.1 of Title 21 of the Code of Federal Regulations as a condition for receiving and conducting clinical pharmacology with a new drug limited by Federal (or United States) law to investigational use.	
1. A STATEMENT OF THE EDUCATION AND TRAINING THAT QUALIFIES ME FOR CLINICAL PHARMACOLOGY _____ _____	
2. THE NAME AND ADDRESS OF THE MEDICAL SCHOOL, HOSPITAL, OR OTHER RESEARCH FACILITY WHERE THE CLINICAL PHARMACOLOGY WILL BE CONDUCTED _____ _____	
3. The investigator assures that an IRB that complies with the requirements set forth in Part 56 of this chapter will be responsible for the initial and continuing review and approval of the proposed clinical study. The investigator also assures that he/she will report to the IRB all changes in the research activity and all unanticipated problems involving risks to human subjects or others, and that he/she will not make any changes in the research that would increase the risks to human subjects without IRB approval. FDA will regard the signing of the Form FD 1572 as providing the necessary assurances stated above.	
4. THE ESTIMATED DURATION OF THE PROJECT AND THE MAXIMUM NUMBER OF SUBJECTS THAT WILL BE INVOLVED _____ _____	

FORM FDA 1572 (10/83) PREVIOUS EDITIONS ARE OBSOLETE.

5. GENERAL OUTLINE OF THE PROJECT TO BE UNDERTAKEN (Modification is permitted on the basis of experience gained without advance submission of amendments to the general outline, but with the approval of the review committee and upon notification of the sponsor.) _____ _____	
6. THE UNDERSIGNED UNDERSTANDS THAT THE FOLLOWING CONDITIONS GENERALLY APPLICABLE TO NEW DRUGS FOR INVESTIGATIONAL USE GOVERN HIS RECEIPT AND USE OF THIS INVESTIGATIONAL DRUG	
a. The sponsor is required to supply the investigator with full information concerning the preclinical investigation that justifies clinical pharmacology. b. The investigator is required to maintain adequate records of the disposition of all receipts of the drug, including dates, quantity, and use by subjects, and if the clinical pharmacology is suspended, terminated, discontinued, or completed, to return to the sponsor any unused supply of the drug. If the investigational drug is subject to the Comprehensive Drug Abuse Prevention and Control Act of 1970, adequate precautions must be taken, including storage of the investigational drug in a securely locked, substantially constructed cabinet, or other securely locked, substantially constructed enclosure access to which is limited, to prevent theft or diversion of the substance into illegal channels of distribution. c. The investigator is required to prepare and maintain adequate case histories designed to record all observations and other data pertinent to the clinical pharmacology. d. The investigator is required to furnish his reports to the sponsor who is responsible for collecting and evaluating the results, and presenting progress reports to the Food and Drug Administration at appropriate intervals, not exceeding 1 year. Any adverse effect which may reasonably be regarded as caused by, or is probably caused by, the new-drug shall be reported to the sponsor promptly; and if the adverse effect is alarming it shall be reported immediately. An adequate report of the clinical pharmacology should be furnished to the sponsor shortly after completion. e. The investigator shall maintain the records of disposition of the drug and the case reports described above for a period of 2 years following the date the new-drug application is approved for the drug; or if no application is to be filed or is approved until 2 years after the investigation is discontinued and the Food and Drug Administration so	notified. Upon the request of a scientifically trained and specifically authorized employee of the Department, at reasonable times, the investigator will make such records available for inspection and copying. The names of the subjects need not be divulged unless the records of the particular subjects require a more detailed study of the cases, or unless there is reason to believe that the records do not represent actual studies or do not represent actual results obtained. f. The investigator certifies that the drug will be administered only to subjects under his personal supervision or under the supervision of the following investigators responsible to him, _____ _____ and that the drug will not be supplied to any other investigator or to any clinic for administration to subjects. g. The investigator certifies that he will inform any patients or any persons used as controls, or their representatives, that drugs are being used for investigational purposes, and will obtain the consent of the subjects, or their representatives, except where this is not feasible or, in the investigator's professional judgment, is contrary to the best interests of the subjects. h. The investigator is required to assure the sponsor that for investigations subject to an institutional review requirement under Part 56 of this chapter the studies will not be initiated until the institutional review board has reviewed and approved the study. (The organization and procedure requirements for such a board as set forth in Part 56 should be explained to the investigator by the sponsor.)
Very truly yours,	
Name of Investigator _____ Address _____ Telephone () _____	

DEPARTMENT OF HEALTH AND HUMAN SERVICES PUBLIC HEALTH SERVICE FOOD AND DRUG ADMINISTRATION STATEMENT OF INVESTIGATOR	Form approved: OMB No. 0910-0013 Expiration Date: December 31, 1984. Note: No drug may be shipped or study initiated unless a completed statement has been received (21 CFR 312.1(a)(12)).
TO: SUPPLIER OF DRUG (Name, address, and Zip Code)	NAME OF INVESTIGATOR (Print or Type)
	DATE
	NAME OF DRUG
Dear Sir: The undersigned, _____, submits this statement as required by section 505(i) of the Federal Food, Drug, and Cosmetic Act and §312.1 of Title 21 of the Code of Federal Regulations as a condition for receiving and conducting clinical investigations with a new drug limited by Federal (or United States) law to investigational use.	
1. THE FOLLOWING IS A STATEMENT OF MY EDUCATION AND EXPERIENCE.	
a. COLLEGES, UNIVERSITIES, AND MEDICAL OR OTHER PROFESSIONAL SCHOOLS ATTENDED, WITH DATES OF ATTENDANCE, DEGREES, AND DATES DEGREES WERE AWARDED	
b. POSTGRADUATE MEDICAL OR OTHER PROFESSIONAL TRAINING. GIVE DATES, NAMES OF INSTITUTIONS, AND NATURE OF TRAINING.	
c. TEACHING OR RESEARCH EXPERIENCE. GIVE DATES, INSTITUTIONS, AND BRIEF DESCRIPTION OF EXPERIENCE.	
d. EXPERIENCE IN MEDICAL PRACTICE OR OTHER PROFESSIONAL EXPERIENCE. GIVE DATES, INSTITUTIONAL AFFILIATIONS, NATURE OF PRACTICE, OR OTHER PROFESSIONAL EXPERIENCE	
e. REPRESENTATIVE LIST OF PERTINENT MEDICAL OR OTHER SCIENTIFIC PUBLICATIONS. GIVE TITLES OF ARTICLES, NAME OF PUBLICATIONS AND VOLUME, PAGE NUMBER, AND DATE.	
IF THIS INFORMATION HAS PREVIOUSLY BEEN SUBMITTED TO THE SPONSOR, IT MAY BE REFERRED TO AND ANY ADDITIONS MADE TO BRING IT UP-TO-DATE.	

FORM FDA 1573 (10/83) PREVIOUS EDITIONS ARE OBSOLETE.

2a. The investigator assures that an IRB that complies with the requirements set forth in Part 56 of this chapter will be responsible for the initial and continuing review and approval of the proposed clinical study. The investigator also assures that he/she will report to the IRB all changes in the research activity and all unanticipated problems involving risks to human subjects or others, and that he/she will not make any changes in the research that would increase the risks to human subjects without IRB approval. FDA will regard the signing of the Form FDA 1573 as providing the necessary assurances stated above. b. A description of any clinical laboratory facilities that will be used. (If this information has been submitted to the sponsor and reported by him on Form FDA 1571, reference to the previous submission will be adequate). 3. The investigational drug will be used by the undersigned or under his supervision in accordance with the plan of investigation described as follows. (Outline the plan of investigation including approximation of the number of subjects to be treated with the drug and the number to be employed as controls, if any; clinical uses to be investigated; characteristics of subjects by age, sex and condition; the kind of clinical observations and laboratory tests to be undertaken prior to, during, and after administration of the drug; the estimated duration of the investigation; and a description or copies of report forms to be used to maintain an adequate record of the observations and test results obtained. This plan may include reasonable alternates and variations and should be supplemented or amended when any significant change in direction or scope of the investigation is undertaken.) 4. THE UNDERSIGNED UNDERSTANDS THAT THE FOLLOWING CONDITIONS, GENERALLY APPLICABLE TO NEW DRUGS FOR INVESTIGATIONAL USE, GOVERN HIS RECEIPTS AND USE OF THIS INVESTIGATIONAL DRUG: a. The sponsor is required to supply the investigator with full information concerning the preclinical investigations that justify clinical trials, together with fully informative material describing any prior investigations and experience and any possible hazards, contraindications, side-effects, and precautions to be taken into account in the course of the investigation. b. The investigator is required to maintain adequate records of the disposition of all receipts of the drug, including dates, quantities, and use by subjects, and if the investigation is terminated, suspended, discontinued, or completed, to return to the sponsor any unused supply of the drug. If the investigational drug is subject to the Comprehensive Drug Abuse Prevention and Control Act of 1970, adequate precautions must be taken including storage of the investigational drug in a securely locked, substantially constructed cabinet, or other securely locked substantially constructed enclosure, access to which is limited, to prevent theft or diversion of the substance into illegal channels of distribution.	c. The investigator is required to prepare and maintain adequate and accurate case histories designed to record all observations and other data pertinent to the investigation on each individual treated with the drug or employed as a control in the investigation. d. The investigator is required to furnish his reports to the sponsor of the drug who is responsible for collecting and evaluating the results obtained by various investigators. The sponsor is required to present progress reports to the Food and Drug Administration at appropriate intervals not exceeding 1 year. Any adverse effect that may reasonably be regarded as caused by, or probably caused by, the new drug shall be reported to the sponsor promptly, and if the adverse effect is alarming, it shall be reported immediately. An adequate report of the investigation should be furnished to the sponsor shortly after completion of the investigation. e. The investigator shall maintain the records of disposition of the drug and the case histories described above for a period of 2 years following the date a new-drug application is approved for the drug; or if the application is not approved, until 2 years after the investigation is discontinued. Upon the request of a scientifically trained and properly authorized employee of the Department, at reasonable times, the investigator will make such records available for inspection and copying. The subjects' names need not be divulged unless the records of particular individuals require a more detailed study of the cases, or unless there is reason to believe that the records do not represent actual cases studied, or do not represent actual results obtained. f. The investigator certifies that the drug will be administered only to subjects under his personal supervision or under the supervision of the following investigators responsible to him, _____ _____ _____ and that the drug will not be supplied to any other investigator or to any clinic for administration to subjects. g. The investigator certifies that he will inform any subjects including subjects used as controls, or their representatives, that drugs are being used for investigational purposes, and will obtain the consent of the subjects, or their representatives, except where this is not feasible or, in the investigator's professional judgment, is contrary to the best interests of the subjects. h. The investigator is required to assure the sponsor that for investigations subject to an institutional review requirement under Part 56 of this chapter the studies will not be initiated until the institutional review board has reviewed and approved the study. (The organization and procedure requirements for such a board as set forth in Part 56 should be explained to the investigator by the sponsor.)
Very truly yours,	
Name of Investigator _____	
Address _____ Telephone () _____	

(This form should be supplemented or amended from time to time if new subjects are added or if significant changes are made in the plan of investigation.)	

STAFF MANUAL GUIDE
 FOOD AND DRUG ADMINISTRATION
 BUREAU OF DRUGS

GUIDE

BD 4831.1

NEW DRUG EVALUATION

IND/NDA MEDICAL REVIEW GUIDELINES

1. Purpose
2. Background
3. Objective
4. Responsibility

Attachment A IND Medical Review Guidelines

Attachment B NDA Medical Review Guidelines

1. **PURPOSE.** This guide provides direction to the medical officer for the preparation of written review of INDs and NDAs.
2. **BACKGROUND.** Before a new drug can be approved for marketing, it must be established through adequate and well-controlled clinical trials that the drug is safe and effective for its labeled indications for use. An IND or NDA is reviewed by at least three scientific disciplines (medicine, pharmacology, and chemistry), and in some instances statistical and/or microbiological reviews may also be needed. The reviewers constitute a team, and each discipline provides its contribution to the ultimate institutional decision.

Each proposed clinical study presents a medical question of whether the study is "reasonably safe" from what is known about the drug. Similarly, each proposal to market a new drug is a medical question of whether the safety and effectiveness data demonstrate that the potential benefits outweigh the potential risks. Because these ultimate decisions are medical questions, the medical officer is designated as the leader of the review team.

Each IND and NDA is assigned to a review division for review and administrative control. The INDs and NDAs in each division are divided between two to four therapeutic drug groups. Medical officers are assigned to a specific therapeutic drug group (usually on the basis of expertise). For each drug group a senior medical officer is designated as group leader.

The group leader assigns new INDs and NDAs to the medical officers working in that group, sets priorities, follows up on pending work, reviews and endorses medical reviews for scientific adequacy and consistency with bureau and agency policy. Differences in opinion between the medical reviewer and the group leader are discussed. Should the difference in opinion remain unresolved, the group leader records the basis for his difference of opinion and recommendation in the file for the Division Director's action.

The medical review of an IND evaluates the safety of the proposed clinical trials, determines if the pharmacologic rationale has been demonstrated, and if the design of the protocols could be expected to produce data that would be useful and consistent with the objectives of the studies. The medical officer, as team leader, with consultation from the pharmacologist and chemist must conclude whether or not it is reasonably safe for clinical studies to begin. If the studies are underway, there is the continuing question of whether new data show it reasonably safe to continue the investigations.

The medical review of the NDA must determine if the clinical studies are adequate and well-controlled and if the results demonstrate the drug is safe and effective for its proposed indications. The medical officer, as team leader, also reviews the findings of the other team members. Based upon his review of the NDA and the findings of the other reviewers he must conclude whether or not the potential benefits expected from the drug satisfactorily outweigh the potential risks for the target population.

3. **OBJECTIVE.** The medical review is a scientific review of the data and information filed by the applicant. The review must contain sufficient analysis and reasoning to assure subsequent readers that each significant study was considered with critical scientific judgement, that salient matters were recognized, and the basis for the scientific conclusions were consistent with the stated findings. Reviews that omit these features generally are difficult to evaluate.

Appendix 23.4. IND/NDA Medical Review Guidelines. (Although the introduction refers to both the IND and NDA, only the IND Medical Review Guidelines (Attachment A), not the NDA Medical Review

The review must be consistent with the Food, Drug and Cosmetic Act, its regulations and HEW and FDA policies. Review documents provide the basis for regulatory and legal actions. Consequently, the document may subsequently be introduced in an administrative hearing or legal contest and the reviewer may be able to testify concerning his findings.

- a. The scientific objectives of the IND review are to:
 - (1) Determine and document whether the available information will allow for assurance of reasonable safety to be afforded subjects involved in the study;
 - (2) Determine whether the studies proposed on the new drug are adequately designed to answer the questions being addressed or which should be addressed at the particular phase of the investigation.
- b. The administrative objectives of the IND review are to:
 - (1) Be easily reviewable by others for content, quality, and reasoning;
 - (2) Be easily translatable into an explicit response to the sponsor clearly stating required or requested action by the sponsor.
- c. In order to meet these scientific and administrative objectives the IND review should:
 - (1) Identify and enumerate specific deficiencies and problems in the submission, if any exists;
 - (2) Assess the regulatory significance of each problem or deficiency;
 - (3) Formulate specific recommendations to correct each problem or deficiency;
 - (4) Recommend specific administrative action based on a cumulative evaluation of all the problems or deficiencies.
- d. The scientific objectives of the NDA review are to:
 - (1) Determine if adequate and well-controlled studies were conducted and if the data show the new drug to be safe and effective for its proposed indications;
 - (2) If so, determine whether any postmarketing studies are necessary as a condition for approval;
 - (3) Determine if the drug's labeling accurately reflects information needed for the proper use of the drug.
- e. The administrative objectives of the NDA review are to:
 - (1) Inform the applicant under what conditions the new drug may be approved for marketing;
 - (2) Inform the applicant, in specific terms, why the data available are not adequate to establish the safety and effectiveness of the new drug and thus may not be approved by FDA for marketing;
 - (3) Be easily reviewable by others for content, quality and reasoning process.
4. **RESPONSIBILITY.** The assigned medical officer is responsible for the primary review, as noted in the review guidelines contained in section 5 and 6 of the IND and NDA submissions. The medical officer is the team leader for the entire scientific review team. Recommendations resulting from the medical officer's review are reviewed by the group leader and then forwarded to the Division Director for concurrence. The group consumer safety officer (CSO) is responsible for drafting an appropriate action letter.

Medical officers should refer to BD Guide 4820.3, "Drug Classification," for guidance in classifying commercially sponsored INDs and NDAs.

GT NO. BD 80-23 (8/14/80)
 ORIGINATOR: New Drug Evaluation

Appendix 23.4—continued

BUREAU OF DRUGS

GUIDE

BD 4831.1

ATTACHMENT A

IND/NDA MEDICAL REVIEW GUIDELINES

IND # _____ M. O. Review _____

Sponsor _____ Date Review Completed _____

1. Resume

This should be a one page summary of the proposed study analogous to the abstract of a scientific paper. The summary should be introduced by a sentence or two classifying the drug, its intended use, its potential clinical advantages, and the general objective of the study. The indication or disease under the study, the type and number of patients, the principal clinical endpoints being utilized, the type of controls and other important characteristics of the study should be included as space and their importance permits. If the design is complete, a flow chart or schema of alternative paths of treatment should be considered for this summary presentation.

This one page abstract should be suitable to stand alone as a summary of the proposed study and should be on a page by itself appropriately identified with provisions for the sponsor's name, date of submission and IND number.

An illustration example (places to be filled in are underlined) follows.

Resume

This IND proposes to study the use of (generic/trade), a (drug category), in (symptom, disease, etc.). One (the) submitted protocol is for an (n-month), (controlled, double-blind, single-blind, etc.) study in (# patients) with (patient characteristics) to (specific objective of the study). The principal investigator (appears/does not appear to be) qualified. (Brief statement about rationale for study; where it fits in overall investigation, why it is being done, if not obvious).

The preclinical data suggest that _____ are particular points of concern and also suggests (important conclusions other than adverse reaction-related ones). Previous study/studies with similar drugs in humans have/have not been carried out and (results regarding safety, appropriate dose, etc., as important).

The proposed study (brief summary and evaluation of experimental procedures emphasizing clinical endpoints, measures to avoid observer bias, and how significance will be assessed). Precautions to be taken include () and (are/are not) adequate.

(The second protocol . . .)

2. General Information

- a. Name of drug
 - (1) Generic;
 - (2) Proposed trade name;
 - (3) Chemical (structure optional);
- b. Pharmacologic Category;
- c. Proposed indication(s);
- d. Dosage form(s) and route(s) of administration;
- e. Related drugs.

3. Manufacturing Controls (refer to Chemistry Review). List any problems with clinical implications, after conference with reviewing chemist.

4. Pharmacology (refer to Pharmacology Review). A brief summary of the following taken from the Pharmacology Review, should be included:

a. Pharmacodynamics

- (1) Primary pharmacologic classification and mechanism of action, if known;
- (2) Other actions;
- (3) Results of human studies, if any.

b. Pharmacokinetics

- (1) Blood level data in animals and humans:
 - (a) Half-life, if known (species variations).
 - (b) Percent absorption by various routes, if known (species variations).
- (2) Excretion—Fraction of absorbed dose eliminated by various routes.
- (3) Distribution—Is there accumulation in particular tissues, exclusion from others?
- (4) Metabolism: Identify metabolites, whether active or not and how they are excreted, if known.

c. Toxicology

- (1) Subacute and Chronic: Positive findings only and range of dosing causing them. If no findings, so state and give highest dose used.
 - (a) General toxicology;
 - (b) Reproduction and toxicology;
 - (c) Carcinogenicity.

d. Conclusions (after conference with pharmacologist).

- (1) Special observations needed during clinical studies on the basis of preclinical findings;
- (2) Maximum duration and dosage of drug administration supported by preclinical data;
- (3) Further data or studies needed (and implications, i.e., may studies proceed while they are being obtained? May clinical studies go beyond Phases I or II or III, etc.?).

5. Clinical Background

- a. Previous similar human studies and their results (including foreign studies).
- b. Literature references that are especially appropriate (summarize the data from each of these published reports).
- c. Important Information from related INDs and NDAs. This section should be pertinent to study design, precautions needed, etc. It may thus be very long or very short, depending on the availability of useful data.

6. Proposed Clinical Studies

- a. Clinical monitor(s) and clinical investigator(s)—Include name, title, business address and identify specifically where the proposed study is to be conducted.

- (1) Is the monitor qualified?
- (2) Is the investigator qualified?
- b. Objective of the study—This should be stated as explicitly and precisely as possible, e.g., "dose-finding study" is not optimal, rather "to find the minimum dose that will produce a (specified) improvement in patients with _____." Other examples would include: "To compare the efficacy (even better, specify the measurement of efficacy to be used) of (a particular dose of _____) with placebo (or another drug, or another dose) in patients with _____."
- c. Rationale for study — Where it fits into overall investigation, why necessary and reasoning behind the proposed use of the drug (if not apparent).
- d. Experimental Design
- (1) Patient Population
- (a) Demography
- number,
 - age,
 - sex,
 - source;
- (b) Clinical characteristics for inclusion such as:
- history,
 - age,
 - physical,
 - lab findings (and comment on adequacy);
- (c) Exclusion, including:
- concurrent diseases not permitted;
 - concurrent medications not permitted (and how concurrent medications will be identified in patient's records);
 - others.
- (2) Procedure
- (a) Specific formulation(s) and lot numbers used in study (including the control drug);
- (b) Type of experimental controls (placebo, active drug, historical), study design (crossover, randomization), and measures to eliminate bias (single-blind, double-blind); comment on appropriateness and adequacy of these procedures;
- (c) Dosage schedule, duration of use, and route of administration for study drug (and placebo, if any); also describe dosage schedule and route for any other drugs that are administered as part of the protocol. Describe special diets to be used. Comment.
- (d) If a copy has been submitted by the sponsor, does the informed consent appear adequate?
- (3) Safety considerations—Observations prior to, during, and after study.
- (a) Clinical studies, i.e., history and physical examinations;
- (b) Laboratory studies

- routine;
 - special studies performed because of the nature of the drug, the patient population involved, results of animal studies, etc.;
- (c) Indications for removing a patient from study (e.g., worsening of symptoms, adverse reactions).
- (4) Efficacy considerations
- Clinical and laboratory measurements used to characterize efficacy or comparability;
 - What degree of difference will be (or was) defined as significant?
 - Are the proposed endpoints appropriate?
- (5) Results of statistical consultation. If none was obtained, indicate at what point in the overall investigation a statistical consultation would be most appropriate.
7. Summary Statements Regarding the Adequacy of the Protocol
All six should be included. Any may be elaborated on as indicated.
- The risks of the proposed study (are/are not) acceptable in view of its objectives.
 - The risks (are/are not) adequately appreciated.
 - Adequate precautions (are/are not) being taken.
 - Patients (are/are not) adequately informed through the informed consent form. (Note that the regulations do not require the investigator or sponsor to submit an informed consent form. If the reviewing division had a particular concern about a drug for safety reasons, then a copy of the consent form should be requested).
 - The study objectives (are/are not) clear and (are/are not) based on a sound rationale.
 - The study protocol (is/is not) adequate to provide data that will achieve the study objectives.
8. Recommended Regulatory Action. One of the following should be included. Any may be elaborated on if the M.O. so desires. In those cases in which other than a standard regulatory action is recommended the rationale should be presented:
- Study may proceed without modification.
 - Study may proceed but would suggest considering the modifications suggested in the deficiency list.
 - Study may proceed if deficiencies _____, _____, _____, . . . are corrected.
 - Study may not proceed until the action taken to correct deficiencies _____, _____, _____, . . . are reviewed by the Agency.
 - Study may not proceed because repeated attempts to demonstrate a scientific rationale (or pharmacologic effect) have not succeeded.
 - Study may not proceed because the serious potential toxicity of the drug outweighs any possible benefit.
9. Deficiency/Problem List. A listing of deficiencies or problems in the submitted protocol or in the IND itself. They may indicate a need for required changes in, or additions to, the protocol or for additional studies, clinical or preclinical, that must be carried out. On the other hand, problems/deficiencies may lead to suggestions for modifications in the protocol or the IND that do not represent requirements, at least at the present time.

Deficiencies/problems should be clearly, concisely stated and appropriately referenced to a particular point in the

submission. The recommended solution (an additional measurement, a new study, etc.) should be stated if it is not clearly implied. Deficiencies/problems will be listed verbatim in the letter to the sponsor. A clear statement of the implications of the problem/deficiency should also be included and will also go into the letter to the sponsor. The nine choices below will cover most situations. (Letters are for in-house use.)

- a. This is a suggestion for improving the study but not a requirement.
 - b. This is a deficiency that must be corrected before an NDA can be approved.
 - c. This is a deficiency that must be corrected before Phase III studies are started.
 - d. This is a deficiency that must be corrected before Phase II studies are started.
 - e. This is a deficiency that must be corrected before Phase I studies are started.
 - f. This is a deficiency that should be corrected during the present study if possible but the study may proceed.
 - g. This is a deficiency that must be corrected during the present study (within _____ days) or the study must be terminated (or, alternatively, no new patients may be added, etc.).
 - h. This is a deficiency that must be corrected before the proposed study is started but the correction need not be reviewed by the Agency before starting the study.
 - i. This is a deficiency that must be corrected and the corrective action reviewed and approved by the Agency before the study is started.
10. IND Review of a Completed Study. This review would begin with a description of the protocol and the study objective (similar to the Resume of the protocol review above). The study would then be reviewed as outlined under the NDA Medical Review Guideline, Section 5 a (4) (a) (b) (c) and (d) and 5 b.

GT NO BD 80-23 (8/14/80)
ORIGINATOR: New Drug Evaluation

Appendix 23.4—continued

IV

*Interactions among
Nuclear Medicine Health
Care Professionals and Patients*

Radiopharmaceutical Information and Consultation Services

*William B. Hladik III, Ned Gregorio, Terry L. Braun,
Victor J. Stathis, and James A. Ponto*

The need for traditional drug information has been evidenced by the growth of drug information centers throughout the United States over the past two decades (1, 2). It generally is accepted that the provision of drug information services to medical professionals has improved the quality of patient care as this growth has occurred (1-4).

The success of drug information centers is based on the fact that they are prepared to answer a wide range of complex questions from a variety of medical specialties. Generally, the answers to the questions asked are beyond the immediate capabilities or resources of the individuals requesting the information. The obvious advantage of employing the services of a drug information center is that these facilities have access to a large pool of information resources and are staffed by individuals who are well trained in retrieving and analyzing literature for solving clinical problems.

It certainly would be convenient for nuclear medicine professionals to have access to an information center to which they could refer for detailed, sophisticated, or perplexing questions. Unfortunately, traditional drug information centers presently are poorly equipped and ill prepared to deal with the information needs of nuclear medicine practitioners. If this is true, the logical question is: "Why doesn't someone in nuclear medicine establish one or more information centers designed to meet the specialized needs of the field?"

In this chapter, therefore, we focus our discussion on:

1. The nature, scope, and depth of typical "drug" or "radiopharmaceutical" information questions that arise in nuclear medicine facilities and
2. Possible approaches for handling and/or processing "radiopharmaceutical" information questions for nuclear medicine, along with exploration of the feasibility of establishing a radiopharmaceutical information center.

TYPE OF INFORMATION NEEDED BY NUCLEAR MEDICINE PROFESSIONALS

For the past several years, the University of New Mexico (UNM) Radiopharmacy has offered an informal consulting service which is utilized primarily (although not exclusively) by local nuclear medicine physicians and technologists as well as by graduates of the UNM radiopharmacy training program (5). Many individuals in this latter group work in the centralized nuclear pharmacy setting and thus represent multiple hospitals nationwide. The experience of the UNM group indicates that information requested by nuclear medicine professionals can generally be categorized into the following nine subject areas:

1. Unusual or unanticipated nuclear medicine study results

Examples: A. If a patient is placed on hemodialysis after administration of [⁶⁷Ga]gallium citrate, will there be any effect on the biodistribution of the radiotracer when the patient is imaged 6 hours later?

B. Do hyperthyroid patients frequently demonstrate thyroid uptake of radiotracer on bone scans?

C. Under what circumstances could a patient have a normal hepatobiliary study with ^{99m}Tc -labeled diisopropyl iminodiacetic acid (DISIDA) and yet on the next day have non-visualization of the liver following administration of ^{99m}Tc -labeled sulfur colloid?

2. Internal radiation dosimetry

Examples: A. What is the radiation dose to the fetus from 10 mCi of sodium [^{131}I]-iodide administered to a woman 2 months pregnant?

B. How soon after receiving a 4 mCi dose of ^{99m}Tc -labeled macroaggregated albumin (MAA) is it safe to breastfeed?

3. Use of interventional drugs and procedures in nuclear medicine studies

Examples: A. What guidelines should be followed when intravenous dipyridamole is administered in conjunction with [^{201}Tl]thallous chloride for myocardial perfusion imaging?

B. What dosage regimen of phenobarbital should be administered to an infant prior to hepatobiliary imaging in order to assist in the differential diagnosis of neonatal jaundice?

4. Pediatric doses of radiopharmaceuticals

Examples: A. How many particles of ^{99m}Tc -MAA should be administered to an infant 3 months old?

B. What dose of sodium [^{123}I]-iodide is appropriate for a 6-year-old, 23-kg euthyroid patient in order to obtain good image quality and yet keep the radiation dose reasonably low?

5. Adverse reactions associated with radiopharmaceuticals

Examples: A. At what point following the administration of ^{99m}Tc -methylene diphosphonate (MDP) is the appearance of a skin rash most likely to occur?

B. Are all adverse reactions reported for ^{99m}Tc -labeled sulfur colloid associated with only one manufacturer's product?

6. Reports of clinical studies documenting the safety and efficacy of a radiopharmaceutical for a new indication

Examples: A. To date, has the information gained from lymphoscintigraphy studies in melanoma patients significantly assisted the surgeon?

B. How sensitive and specific is the combination of [^{201}Tl]thallous chloride and sodium [^{99m}Tc]pertechnetate for the detection of parathyroid adenomas?

7. Specific physicochemical, pharmaceutical, or kinetic properties of radioactive drugs

Examples: A. How quickly is ^{99m}Tc -dimercaptosuccinic acid (DMSA) cleared from the blood in a patient with a creatinine clearance of 40 ml/min?

B. Have there been any reported problems with administration of sodium [^{131}I]iodide in capsular form rather than in solution?

8. Formulation, preparation, and quality assurance of radiopharmaceuticals

Examples: A. What is the best thin-layer chromatography system for performance of radiochemical purity testing of ^{99m}Tc -DISIDA?

B. From a radionuclidic purity standpoint, is it safe to administer [^{201}Tl]thallous chloride at 4 days precalibration?

9. Regulatory requirements associated with the clinical use of approved and investigational radiopharmaceuticals

Examples: A. Is it necessary to submit an IND in order to routinely use ^{99m}Tc -labeled sulfur colloid in scrambled eggs for gastric emptying studies?

B. Does the local Radioactive Drug Research Committee (RDRC) have authority to approve research designed to study the biodistribution of ^{99m}Tc -gentamicin in 10 normal volunteers?

Because each of the nine categories is associated in some way with the preparation or clinical use of radiotracer drugs, inquiries associated with these topics could logically be called "radiopharmaceutical information" questions, which is analogous to the more conventional term, i.e., "drug information" questions. The former, however, is obviously more appropriate for the specialty area of clinical nuclear medicine. Hereafter, the term "radiopharmaceutical information" is used to represent the concept of information needs in nuclear medicine.

Although challenging, if not puzzling, questions do arise in each of the nine subject areas, inquiries pertaining to unusual or unanticipated nuclear medicine study results are, by far, the most common. Therefore, exploration of this particular area in more detail, so that the complexity of the subject can be better appreciated, may be worthwhile.

Two principal phenomena may cause unusual or unanticipated nuclear medicine study results: (a) altered biodistribution or biorouting of radiopharmaceuticals and (b) miscellaneous technical artifacts. Multiple underlying factors may be responsible for these phenomena; some of the more frequently encountered factors are found in Tables 24.1 and 24.2.

The most difficult part of dealing with unusual or unexpected study results is sorting through all the factors that may be responsible for the occurrence and then pinpointing the one(s) applicable in a particular case. In other words, the challenge is to determine the cause of the observed results in a specific patient, with the many possibilities kept in mind. Consider

Table 24.1.

Causes of Altered Biodistribution or Biorouting of Radiopharmaceuticals

Nonradioactive drug therapy
Iatrogenic trauma (surgery)
Renal dialysis
Radiation therapy
Blood transfusions
Unexpected pathophysiologic interference
Inappropriate injection techniques
Radiopharmaceutical formulation problems

Table 24.2.

Miscellaneous Technical Artifacts

Inappropriate sequencing of studies
Instrumentation failure
Operator error
Patient-induced errors
Other imaging artifacts

the following typical radiopharmaceutical information requests:

1. Radioactivity is visualized in the lungs of a patient injected with ^{99m}Tc -labeled sulfur colloid.
2. The liver is clearly observed on a ^{99m}Tc -MDP bone scan.

What could have caused the altered radiopharmaceutical biodistribution pattern in each of these cases? The first step in answering this question is to search the literature by utilizing various information retrieval systems (or by using a database specific for nuclear medicine) in order to locate those factors that are associated with pulmonary accumulation of ^{99m}Tc -labeled sulfur colloid (Table 24.3) and liver uptake of ^{99m}Tc -labeled bone imaging agents (Table 24.4). Next, patient data, technical parameters, and other case-related information can be integrated into the problem-solving process in order to determine the reason for the lung uptake of radiocolloid (or liver uptake of ^{99m}Tc -MDP) in the case in question. Alternatively, a computer program could be developed to directly interface literature references (database) with case-specific data, thus meshing the previous two steps into one.

The provision of radiopharmaceutical information should be individualized, i.e., made specific to the patient, whenever possible. The feasibility of providing patient-specific responses ("output" information) depends largely on the quantity and quality of case "input" data that is received from the caller. This concept is discussed in more detail later in the chapter.

One should keep in mind that the literature may not be of help in suggesting, identifying, or substantiating the cause of the altered biodistribution in a specific case. If this situation

Table 24.3.
Factors Associated with Pulmonary Uptake of ^{99m}Tc -labeled Colloids

Factors	References
Al^{+3} (aluminum antacids)	33, 58
Bacterial endotoxin	19, 24, 45
Malignant lymphoma	20
Spleen and/or bone marrow transplant	20, 31, 58
Intra-abdominal abscesses	19, 58
Advanced breast carcinoma	28
Mucopolysaccharidosis type II (Hunter)	30, 58
Falciparum malaria	27
Histiocytosis X	37, 58
Liver transplant	31
Variation in colloid preparations (e.g., macroaggregation of the radiopharmaceutical and other technical factors)	19, 21, 30, 32, 34, 35, 39, 40, 42, 46, 50, 51, 58
Hepatocellular disease, hepatic failure, and/or intrahepatic cholestasis	19, 21, 34, 48, 49, 58
Liver angiosarcoma	16
Acute infection superimposed on alcoholic hepatitis	16
Children (? normal finding)	36, 58
Disseminated intravascular coagulation	17, 61
Neoplasia (various)	19, 58
Systemic amyloidosis	18, 43, 58
Intravascular clot	39
Exogenous reticuloendothelial system stimulants	19, 44, 49
Atelectasis (focal uptake)	52
Trauma	57
Hepatoma	58
Hypercoagulability	58
Infectious mononucleosis	59
Lassa fever	60
Miscellaneous supportive data	22, 23, 25, 26, 29, 38, 41, 47, 53-56

occurs, important facts or concepts gained from the case should be submitted for publication to afford a broader base of information to individuals subsequently searching for data on the same, or a closely related, topic.

Selected radiopharmaceutical information resources for each of the nine subject areas discussed previously are given in Appendix 24.1. In addition, journals that often include articles pertaining to radiopharmaceuticals and/or nuclear medicine are listed in Appendix 24.2. This list does not include journals from other medical specialties (e.g., cardiology, gastroenterology, orthopedics) that occasionally may include articles relevant to nuclear medicine.

ADVANTAGES OF ESTABLISHING A RADIOPHARMACEUTICAL INFORMATION CENTER

In his book, *Megatrends*, author John Naisbitt states that 6000 to 7000 scientific articles are written each day (6). This translates into an overall increase in scientific and technical information of 13%/year; at this rate, the base of information doubles every 5.5 years. The rate soon will jump to perhaps 40%/year because new, more powerful information systems and an increasing number of scientists will be available. The base of information will then double every 20 months. In 1982, Naisbitt predicted

Table 24.4.
Factors Associated with Liver Uptake of Bone Imaging Agents

Factors	References
Cholangiocarcinoma	76
Liver metastases from:	
Adenocarcinoma of colon	62, 70, 74, 76-78, 98
Adenocarcinoma of pancreas	65
Stomach carcinoma	73
Breast carcinoma	84, 98
Squamous cell carcinoma of esophagus	81
Mucinous adenocarcinoma of rectum	79
Malignant melanoma	75, 93, 97
Oat cell carcinoma of lung	64, 68
Ovarian carcinoma	66, 71
Lymphoma	94, 95
Hepatic necrosis	62, 67, 86, 88, 103
Amyloidosis	72
Hypercalcemia, calcification	68, 69, 71, 79, 81, 87, 96, 99, 100
Increased quantities of iron in liver: thalassemia major	63
Positioning artifact: spinal "shine through"	62
Apparent uptake due to abdominal wall or rib uptake	77
Artifactual (due to prior ^{99m}Tc -labeled sulfur colloid study)	76
Elevated serum Al^{+3}	82, 89
Following radiographic contrast material	85
Specific drug therapy	90, 92
Probable colloid formation due to:	
Preparation of kit at alkaline pH	77, 82, 91
Incompatibility of kit pH and generator pH	83
Preparation of kit in presence of elevated Al^{+3} (from generator eluate)	80, 82, 102
Leukemia	101

that by 1985 the volume of information would be between 4 and 7 times what it was in 1980 (6). These statements describe an uncontrolled and, probably, an unorganized information explosion and could, logically, lead those who try to locate or utilize the information to the conclusion that this resource is more of a hindrance than a help. Use of this resource will become so cumbersome that users will, in increasing numbers, pay to locate the specific information they need.

Nuclear medicine is a growing medical profession with a scientific and technical base about which physicians, technologists, pharmacists, and allied health professionals all have questions and information needs. Despite the

excellent effort of institutions to provide needed information, it should be realized that these endeavors are extremely time consuming. Additionally, as stated at the beginning of the chapter, the answer to the questions are often beyond the immediate capabilities or resources of the institution itself. One very practical medium to effectively and efficiently control information needs is a centralized information center. Obviously, one person for each nuclear medicine facility or one person for each metropolitan area is no longer a viable approach to processing the information needs of the nuclear medicine community. One solution to this situation might be to establish a nationwide center or several regional, but strategically located, information

centers to serve all nuclear medicine facilities. Another solution might be to form a network of information centers, each of which specializes in one or more of the nine information subject areas previously described. A logical name for these facilities might be "radiopharmaceutical information centers" (RPIC).

During the following discussion of the advantages of establishing an RPIC, many parallels between the traditional drug information center and the proposed RPIC are evident.

1. Qualified Staff

The staff of the RPIC should be familiar with traditional sources of medical information about nonradioactive drugs as well as diagnostic and therapeutic radiopharmaceuticals. In addition, the staff members should be experts on the content and use of existing databases and retrieval systems.

2. Rapid Access to Current Literature and Other Resources

A complete library of books and access to major journals in nuclear medicine should be available. Reference material such as that listed in Appendices 24.1 and 24.2 should be continually expanded and updated to enable the staff to efficiently locate and retrieve information.

3. Quality Assurance of Radiopharmaceutical Information

The center could respond to questions by verbal and/or written responses as deemed appropriate. The responses that the center would give to callers could be critically evaluated by use of methods commonly employed by traditional drug information centers to ensure quality, accuracy, and timeliness.

4. Clearinghouse for INDs

The RPIC could coordinate the establishment of a bank of investigational protocols accessible to all facilities. Many nuclear medicine departments become involved with investigational procedures and INDs much in advance of subsequent Food and Drug Administration (FDA) approval. The most recent example is ¹¹¹In-labeled leukocytes. As a special service, the RPIC could bank all INDs voluntarily submitted to the center and arrange for distribution to interested parties.

5. Consulting Expertise in Troubleshooting Unusual Scan Results

As discussed previously, nuclear medicine personnel quite frequently inquire about the circumstances responsible for unexpected study results, i.e., unusual radiotracer localization. The center should be uniquely qualified to locate the specific information needed in order to systematically determine the cause(s) of unanticipated or unusual radiopharmaceutical bi-routing.

6. Capability of Expanding into Other Areas of Radiology

With only slight modification, the RPIC could be equipped to provide information on all drugs and related medicinals used in radiology, including not only radiopharmaceuticals for nuclear medicine but also contrast agents for diagnostic radiology, new compounds in ultrasound, and magnetopharmaceuticals for magnetic resonance imaging studies.

7. Capability of Developing a Database Specific to Nuclear Medicine (or Diagnostic Imaging)

Over a period of time, the logical goal of the RPIC staff might be to coordinate the establishment of a searchable, on-line database, to include literature that is specific for nuclear medicine and/or the entire gamut of diagnostic imaging modalities. The significance of this proposed project stems from the fact that the existing databases, e.g., MEDLINE, do not index articles from all of the journals that publish information on nuclear medicine. MEDLINE, for instance, indexes only about half of the journals listed in Appendix 24.2 (7). The feasibility of developing this database depends largely on the size and workload of the RPIC staff and/or on the amount of outside reviewers that could contribute to the indexing of information contained in the database. This database, which might be called NUCL-MEDLINE or RADIOLINE, could be accessible to users nationwide on a subscription basis, in a manner similar to other databases.

8. Convenient Access to the Information Center

The center should be accessible by a toll free telephone number during normal business hours. During nonbusiness hours and weekends, a message service should be available.

EVOLVING CONCEPTS IN NUCLEAR MEDICINE RELEVANT TO ESTABLISHMENT OF AN RPIC

Hospitals have been perceived by the general public, as well as by the government, as being profit motivated. This perception is no illusion, as hospitals have consistently shown profit and revenue increases year after year. Moreover, because hospitals generally were not held accountable for their expenses, there was no motivation for them to be cost efficient under the old method of governmental reimbursement (8). It became apparent that the third party reimbursement method was obsolete; as a result, the government decided to make a radical change. Prospective payment, the method currently used by the government, is a flat rate set in advance of care based on a diagnosis-related group (DRG) (8, 9). The prospective payment method will be expanded in the future to include all payors and providers. Obviously, the era of prospective payment will be an ever-present reality for hospitals to cope with in their effort to remain profitable.

A major activity evident in all hospital departments is the task of defining strategies that can be employed in order to economically function below the flat rate provided under each DRG. Controlling costs, increasing productivity, and utilizing resources effectively are three main methods used (10). The following concepts, which could have a large impact on supplementing these activities or methods, deserve to be considered by nuclear medicine practitioners.

The first concept is the reemphasis of the diagnostic imager as a true consultant (9, 11). Understanding the role that nuclear medicine plays in a patient's therapeutic and diagnostic management, coupled with the ability to communicate this information to referring physicians, will enhance the proper utilization of this diagnostic imaging modality. Eventually, peer review organizations will be established to look explicitly at the utilization of various imaging procedures. In addition, they will also review the validity of patient diagnosis and monitor the quality of care received (10). The decisions that the diagnostic imager will make, based on the

nuclear medicine study, may alter, confirm, or further clarify the patient's management. In complex clinical situations, information provided by the RPIC may significantly add to the overall data required by the physician in order to make appropriate diagnostic decisions.

The second concept is concerned with improving the efficiency of performing a nuclear medicine study (9). Efficiency, in this sense, can be defined as the fastest progression of the patient through the diagnostic procedure. One approach to increase efficiency is through the prospective screening of patient data in order to identify any problems that may interfere with the procedure, thus causing misdiagnoses or unnecessary delays, costs, or exposure to radiation. Computerization of patient medical data should allow professionals to rapidly search for factors that may (a) indicate inappropriate use or sequencing of diagnostic tests, (b) preclude a patient from undergoing a particular nuclear medicine procedure, or (c) interfere with interpretation of study results (12).

Certain diseases, medications, or invasive medical procedures are known to alter birouting of radiopharmaceuticals, thus causing confusion for the nuclear medicine physician. For example, propranolol, a drug commonly used in patients with cardiac disease, improves myocardial blood flow to ischemic areas. By virtue of this hemodynamic effect, propranolol has been reported to reduce the sensitivity of [²⁰¹Tl]thallous chloride imaging by masking underlying coronary artery disease (13, 14). Therefore, it is obvious that the diagnostician should be aware of all medications (and other factors) that may interfere with, or complicate, the outcome of the study. In this regard, the RPIC could distribute information to be used in writing or updating computer programs designed to scan the patient's medical database and flag factors that may change the entire course of the procedure or alter the study results.

These two concepts are provided to show how nuclear medicine can strengthen its financial position under prospective payment through the establishment of an RPIC. Ideally, each facility would have the motivation and qualified personnel to aid the physician in solving problematic

patient cases before, during, and after the procedure; presently, this very often does not occur. The RPIC could be an ideal mechanism through which these evolving concepts, discussed previously, could materialize.

OPERATIONAL ASPECTS OF THE RPIC: IMPORTANCE OF QUALITY ASSURANCE

On a daily basis, the RPIC would undoubtedly receive numerous inquiries from a variety of callers. The operation of the RPIC would be dependent on the acquisition of complete input data and the provision of accurate and thorough output data. Therefore, the quality of both input information and output information would have to be continually evaluated by the RPIC. Input information is the data extracted from the caller that is required in order to formulate a patient-specific answer to the inquiry. To retrieve appropriate literature resources by use of the established computer database, it is necessary to know the entire set of circumstances associated with the case in question. It would be the responsibility of the RPIC staff to ensure that all pertinent facts are obtained before its members attempt to formulate a response. A computer program that prompts RPIC staff members to ask the caller questions that will facilitate the gathering of all essential facts could be employed to assure the quality and completeness of input data. This type of interaction with use of both open-ended and directed questions would enable the caller to reflect on factors concerning the patient and any technical information not immediately obvious to him.

The RPIC should be able to provide objective evaluation of the responses (output data) given to callers. Some key points to consider with respect to the information to be provided include the following:

1. In most cases, the RPIC should be able to answer patient-specific questions adequately by computer-assisted retrieval of archived literature citations and previous consultations or through logical deduction.
2. The RPIC should be able to evaluate quickly the verbal and written responses with regard to completeness, accuracy, appropriateness,

and caller satisfaction. Within a reasonable time, the responses could also be evaluated for timeliness as well as clinical and financial impact through a feedback mechanism arranged with the caller.

A review of the quality assurance methods used by traditional drug information centers provides useful information for developing a similar quality assurance program for the RPIC (15). As expected, these programs are established to ensure quality radiopharmaceutical information and to identify and solve problems associated with provision of this information. One possible means to accomplish this task would be through the formation of a committee consisting of various nuclear medicine professionals who would review information provided by the RPIC on a regularly scheduled basis.

SUMMARY

In this chapter, the information needs of the nuclear medicine community are discussed, and a workable and efficient approach to handling these information needs is suggested. Specifically, the establishment of an RPIC and/or the development of an on-line database might provide nuclear medicine professionals with information needed to answer important clinical or research questions. Providing radiopharmaceutical information by use of the same methods as traditional drug information centers should have a positive impact on nuclear medicine, both clinically and financially.

REFERENCES

1. Cardoni AA: Drug information centers: meeting future needs for drug information. *Am J Hosp Pharm* 40:1215-1217, 1983.
2. Amerson AB, Wallingford DM: Twenty years' experience with drug information centers. *Am J Hosp Pharm* 40:1172-1178, 1983.
3. Cardoni AA, Thompson TJ: Impact of drug information services on patient care. *Am J Hosp Pharm* 35:1233-1237, 1978.
4. Keys PW, South JC, Duffy MG: Quality of care evaluation applied to clinical pharmacy services. *Am J Hosp Pharm* 32:897-902, 1975.
5. Rhodes BA, Cordova MA, Hladik WB III: Radiopharmacy information needs within the nuclear medicine community. In Colombetti LG (ed): *Advances in Radiopharmacology*. Chicago, International Association of Radiopharmacology, 1981, pp 228-233.
6. Naisbitt J: *Megatrends—Ten New Directions Trans-*

forming Our Lives. New York, Warner Books, 1982

7. *List of Journals Indexed by Index Medicus 1986*, NIH Publication No. 86-267. Bethesda, MD, The National Library of Medicine, 1986, p 158.
8. Ernstthal HL: Changing methods of health care financing: the impact of DRGs on nuclear medicine. *J Nucl Med Technol* 12:78-83, 1984.
9. Muroff LR, Splitstone GD: Prospective nuclear medicine DRGs and the diagnostic imager: a look to the future—positive aspects, trends, and future challenges. *Curr Concepts Diagn Nucl Med* 2(1):18-20, 1984.
10. *Prospective Payment and Nuclear Medicine: Concept, Impact and Action—Symposia Summary*. Boston, New England Nuclear/DuPont, 1984.
11. Baker SR: The radiologist as clinical activist. *Appl Radiol* 15(1):18-24, 1986.
12. Thompson WL, Murphy PH, Moore WH, et al: Integration of database capabilities into a patient reporting system. *J Nucl Med* 26:770-774, 1985.
13. Hockings B, Saltissi S, Croft DN, et al: Effect of beta adrenergic blockade on thallium-201 myocardial perfusion imaging. *Br Heart J* 49:83-89, 1983.
14. Henkin RE, Chang W, Provus R: The effect of beta blockers on thallium scans. *J Nucl Med* 23:P63, 1982.
15. Thompson DF, Heflin NR: Quality assurance in drug information and poison centers: a review. *Hosp Pharm* 20:758-760, 1985.
16. Imarisio JJ: Liver scan showing intense lung uptake in neoplasia and infection. *J Nucl Med* 16:188-190, 1975.
17. Smith FW, Brown RG, Ash JM, et al: Accumulation of Tc-99m sulfur colloid by the lung and kidney following disseminated intravascular coagulation. *Clin Nucl Med* 5:241-244, 1980.
18. Andujar MA, Valdez VA, Herrera NE: Abnormal distribution of ^{99m}Tc-sulfur colloid in a patient with systemic amyloidosis. *Clin Nucl Med* 3:346-348, 1978.
19. Keyes JW, Wilson GA, Quinones JD: An evaluation of lung uptake of colloid during liver imaging. *J Nucl Med* 14:687-691, 1973.
20. Klingensmith WC III, Ryerson TW: Lung uptake of ^{99m}Tc-sulfur colloid. *J Nucl Med* 14:201-204, 1973.
21. LaRocque LR: Uptake of sulfur colloid by liver, spleen, lungs and skeleton. *J Nucl Med Technol* 6:214-216, 1978.
22. Klingensmith WC III, Yang SL, Wagner HN Jr: Lung uptake of Tc-99m-sulfur colloid in liver and spleen imaging. *J Nucl Med* 19:31-35, 1978.
23. Turner JW, Syed IB, Hanc RP: Retention of ^{99m}Tc sulfur colloid in the lungs (letter to the editor). *J Nucl Med* 16:249-250, 1975.
24. Henry RE, Somogyi MM, Hendershott LR, et al: Accumulation of Cr-51 platelets, I-125 fibrinogen and Tc-99m sulfur colloid (TSC) in the lungs following endotoxin administration (abstract). *J Nucl Med* 17:543, 1976.
25. Turner JW, Syed IB, Hanc RP: Lung uptake of ^{99m}Tc sulfur colloid during liver scanning. *J Nucl Med* 15:460-462, 1974.
26. Klingensmith WC III, Tsan MF, Wagner HN Jr: Factors affecting the uptake of ^{99m}Tc sulfur colloid by the lung and kidney. *J Nucl Med* 17:681-684, 1976.
27. Ziessman HA: Lung uptake of ^{99m}Tc-sulfur colloid in falciparum malaria: case report. *J Nucl Med* 17:794-796, 1976.
28. Gillespie PJ, Alexander JL, Edelstyn GA: High concentration of ^{99m}Tc-sulfur colloid found during routine liver scan in lungs of patients with advanced breast cancer. *J Nucl Med* 14:711-712, 1973.
29. Klingensmith WC III, Lovett VJ Jr: Lung uptake of ^{99m}Tc-sulfur colloid secondary to intraperitoneal endotoxin. *J Nucl Med* 15:1028-1031, 1974.
30. Klingensmith WC III, Eikman EA, Maumenee I, et al: Widespread abnormalities of radiocolloid distribution in patients with mucopolysaccharidoses. *J Nucl Med* 16:1002-1006, 1975.
31. Klingensmith WC III, Ryerson TW, Corman JL: Lung uptake of ^{99m}Tc-sulfur colloid in organ transplantation. *J Nucl Med* 14:757-759, 1973.
32. Kristensen K, Pedersen B: Lung retention of ^{99m}Tc-sulfur colloid (letter to the editor). *J Nucl Med* 16:439-441, 1975.
33. Bobinet DD, Sevrin R, Zurbriggen MT, et al: Lung uptake of ^{99m}Tc-sulfur colloid in patients exhibiting presence of Al³⁺ in plasma. *J Nucl Med* 15:1220-1222, 1974.
34. Steinbach HL: Pulmonary accumulation of ^{99m}Tc technetium sulfur colloid during liver scanning. *Tex Med* 68:137-138, 1972.
35. Bruun P: A comment on the possibility of ^{99m}Tc-sulfur colloid retention in the lungs (letter to the editor). *J Nucl Med* 15:726-728, 1974.
36. Winter PF, Perl LJ, Johnson PM: Lung uptake of colloid during liver-spleen scanning: a normal finding in children. *Nuklearmedizin* 15:294-296, 1976.
37. Bowen BM, Coates G, Garnett ES: Technetium ^{99m}-sulfur colloid lung scan in patients with histiocytosis X (letter to the editor). *J Nucl Med* 16:332, 1975.
38. Kim EE, Coupal JJ, Deland FH, et al: Docs human serum cause aggregation of injected radiocolloid (abstract)? *J Nucl Med* 19:685-686, 1978.
39. Weinstein ME, Smoak W: The authors' reply (letter to the editor). *J Nucl Med* 11:767-768, 1970.
40. Coupal JJ: Do colloids cause you problems—a clear solution isn't in sight (editorial). *J Nucl Med* 18:852-853, 1977.
41. Klingensmith WC III, Tsan MF, Hsu CK, et al: Intravascular phagocytic activity of the lung during varying levels of circulating monocytes and neutrophils. *J Reticuloendothel Soc* 19:375-381, 1976.
42. Park CH, Mansfield CM: The recognition and interpretation of extrahepatic uptake of ^{99m}Tc-sulfur colloid in liver scanning. *J Natl Med Assoc* 65:104-107, 1973.
43. Castleman B, Scully RE, McNeely BU (eds): Case records of the Massachusetts General Hospital (case 25-1974). *N Engl J Med* 290:1474-1481, 1974.

44. Mikhael MA, Evans RC: Migration and embolization of macrophages to the lung—a possible mechanism for colloid uptake in the lung during liver scanning. *J Nucl Med* 16:22–27, 1975.
45. Quinones JD: Localization of technetium-sulfur colloid after RES stimulation (abstract). *J Nucl Med* 14:443–444, 1973.
46. Coupal JJ, Deland FH, Kim EE: Biological distribution of various size colloidal particles in disease states (abstract). *J Nucl Med* 18:621, 1977.
47. Coupal JJ, Kim EE, Lovelace DR, et al: Lung radioactivity seen on colloid liver scan: association with serum chemistry parameters (abstract). In: *Proceedings of the APhA Academy of Pharmacy Practice Annual Meeting*. Washington DC, 1980, p 63.
48. Coupal JJ, Kim EE, Deland FH: Association of physiologic and pathologic parameters with altered biodistribution of radiocolloid. In Colombetti LG (ed). *Advances in Radiopharmacology*. Chicago, International Association of Radiopharmacology, 1981, pp 245–258.
49. Sy WM, Malach M: Lung uptake on ^{99m}technetium liver scan (editorial). *Chest* 68:613–614, 1975.
50. Haney TA, Ascanio I, Cighotti A, et al: Physical and biological properties of a ^{99m}Tc-sulfur colloid preparation containing disodium edetate. *J Nucl Med* 12:64–68, 1971.
51. French RJ: The preparation of a technetium colloid and an indium colloid for liver scanning. *Br J Radiol* 42:68–69, 1969.
52. Mettler FA, Christie JH: Focal lung uptake of Tc-99m-sulfur colloid. *Clin Nucl Med* 6:322–323, 1981.
53. Zweifach BW: An analysis of the inflammatory reaction through the response of the terminal vascular bed in microtrauma. *Rev Can Biol* 12:179–188, 1953.
54. Vanfurth R: Origin and kinetics of monocytes and macrophages. *Semin Hematol* 7:125–141, 1970.
55. Schneeberger-Keeley EE, Burger EJ: Intravascular macrophages in cat lungs after open chest ventilation. An electron microscopic study. *Lab Invest* 22:361–369, 1970.
56. Simpson ME: The experimental production of macrophages in the circulating blood. *J Med Res* 43:77–144, 1922.
57. Johnson RA, Hladik WB: Post-traumatic pulmonary accumulation of Tc-99m sulfur colloid. *J Nucl Med* 23:147–148, 1982.
58. Stadalnik RC: Diffuse lung uptake of Tc-99m-sulfur colloid. *Semin Nucl Med* 10:106–107, 1980.
59. Hammes CS, Landry AJ, Bunker SR, et al: Diffuse lung uptake of Tc-99m-sulfur colloid in infectious mononucleosis. *J Nucl Med* 24:1083–1084, 1983.
60. Marigold JH, Clarke SEM, Gaunt JJ, et al: Lung uptake of Tc-99m-tin colloid in a patient with lassa fever. *J Nucl Med* 24:750–751, 1983.
61. Teertstra HJ, Ras GJ, Verdegaaal WP: Lung and renal uptake of technetium Tc-99m-sulfur colloid related to disseminated intravascular coagulation. *Eur J Nucl Med* 10:13–16, 1985.
62. White S, Cox D, Eklem M, et al: Liver uptake of bone seeking radiopharmaceuticals. *Clin Nucl Med* 7:P44, 1982.
63. Valdez VA, Jacobstein JG: Visualization of the liver with Tc-99m-EHDP in thalassemia major. *Gastrointest Radiol* 6:175–176, 1981.
64. Kim EE, Domstad PA, Choy YC, et al: Accumulation of Tc-99m phosphonate complexes in metastatic lesions from colon and lung carcinomas. *Eur J Nucl Med* 5:299–301, 1980.
65. Ghaed N, Marsden RJ: Accumulation of Tc-99m diphosphonate in hepatic neoplasm. *Radiology* 126:192, 1978.
66. Debois JM: Uptake of Tc-99m diphosphonate in liver metastasis of an ovarian carcinoma. *Eur J Nucl Med* 6:273–275, 1981.
67. Lyons KP, Kuperus J, Green HW: Localization of Tc-99m pyrophosphate in the liver due to massive liver necrosis: case report. *J Nucl Med* 18:550–552, 1977.
68. Oren VO, Uszler JM: Liver metastases of oat cell carcinoma of lung detected on the Tc-99m diphosphonate bone scan. *Clin Nucl Med* 3:355–358, 1978.
69. Dudezak R, Angelberger P, Kletter K, et al: Transient accumulation of Tc-99m MDP in the liver. *Eur J Nucl Med* 5:189–191, 1980.
70. Garcia AC, Yeh SDJ, Benua RS: Accumulation of bone-seeking radionuclides in liver metastasis from colon carcinoma. *Clin Nucl Med* 2:265–269, 1977.
71. Gates GF: Ovarian carcinoma imaged by Tc-99m-pyrophosphate: case report. *J Nucl Med* 17:29–30, 1976.
72. Vanek JA, Cook SA, Bukowski RM: Hepatic uptake of Tc-99m-labeled diphosphonate in amyloidosis: case report. *J Nucl Med* 18:1086–1088, 1977.
73. Tonami N, Maeda T, Aburano T, et al: Marginal accumulation of Tc-99m methylene diphosphonate in liver metastasis from stomach carcinoma. *Eur J Nucl Med* 6:43–45, 1981.
74. Stevens JS, Clark EE: Liver metastasis of colon adenocarcinoma demonstrated on Tc-99m pyrophosphate bone scan. *Clin Nucl Med* 2:270–271, 1977.
75. DeLong JF, Leonard JC, Allen EW: Case report: Tc-99m diphosphonate concentration in a malignant melanoma metastatic to liver. *Trans Equilib* 6:1, 1977.
76. Guiberteau MJ, Potsaid MS, McKusick KA: Accumulation of Tc-99m diphosphonate in four patients with hepatic neoplasm: case reports. *J Nucl Med* 17:1060–1061, 1976.
77. Poulouse KP, Reba RC, Eckelman WC, et al: Extrasosseous localization of Tc-99m-Sn pyrophosphate. *Br J Radiol* 48:724–726, 1975.
78. Balachandran S: Localization of Tc-99m-Sn pyrophosphate in liver metastasis from carcinoma of colon. *Clin Nucl Med* 1:165, 1976.
79. Kirby JC, Bartow JH, Dresser TP, et al: Accumulation of MDP in hepatic metastases from mucinous adenocarcinoma of the colon. *Clin Nucl Med* 7:25–27, 1982.
80. Chaudhuri TK: Liver uptake of Tc-99m diphosphonate. *Radiology* 119:485–486, 1976.
81. Wilkinson RH Jr, Gaede JT: Concentration of Tc-99m methylene diphosphonate in hepatic metastases from squamous cell carcinoma. *J Nucl Med* 20:303–305, 1979.
82. Chaudhuri TK: The effect of aluminum and pH on altered body distribution of Tc-99m EHDP. *Int J Nucl Med Biol* 3:37–38, 1976.
83. Aidridge RE: Case of the quarter. *J Nucl Med Technol* 4:89–90, 1976.
84. Baumert JE, Lantieri RL, Horning S, et al: Liver metastases of breast carcinoma detected on Tc-99m methylene diphosphonate bone scan. *AJR* 134:389–391, 1980.
85. Crawford JA, Gumerman LW: Alteration of body distribution of Tc-99m pyrophosphate by radiographic contrast material. *Clin Nucl Med* 3:305–307, 1978.
86. Echevarria RA, Bonanno C, Davis DK: Uptake of Tc-99m pyrophosphate in liver necrosis. *Clin Nucl Med* 2:322–323, 1977.
87. Fratkin MJ: Hepatic uptake of bone imaging radiopharmaceuticals. *Clin Nucl Med* 2:286–287, 1977.
88. Hansen S, Stadalnik RC: Liver uptake of Tc-99m pyrophosphate. *Semin Nucl Med* 12:89–91, 1982.
89. Zimmer AM, Pavel DG: Experimental investigations of the possible cause of liver appearance during bone scanning. *Radiology* 126:813–816, 1978.
90. Lentle BC, Scott JR, Noujaim AA, et al: Iatrogenic alterations in radionuclide biodistributions. *Semin Nucl Med* 9:131–143, 1979.
91. Eckelman WC, Reba RC, Kubota H, et al: Tc-99m pyrophosphate for bone imaging. *J Nucl Med* 15:279–283, 1974.
92. Hladik WB, Nigg KK, Rhodes BA: Drug induced changes in the biologic distribution of radiopharmaceuticals. *Semin Nucl Med* 12:184–218, 1982.
93. Powers CI, Lin DS, Lin CM: Liver localization of ^{99m}Tc MDP in a case of metastatic malignant melanoma. *Int J Nucl Med Biol* 11:73–76, 1984.
94. Stone CK, Sisson JC: What causes uptake of technetium-99m methylene diphosphonate by tumors? A case where the tumors appeared to secrete a hypercalcemia-causing substance. *J Nucl Med* 26:250–253, 1985.
95. Williamson BRJ, Carey RM, Innes DJ Jr, et al: Poorly differentiated lymphocytic lymphoma with ectopic parathormone production: visualization of metastatic calcification by bone scan. *Clin Nucl Med* 3:382–384, 1978.
96. Rosenfield N, Treves S: Osseous and extrasosseous uptake of fluorine-18 and technetium-99m polyphosphate in children with neuroblastoma. *Radiology* 111:127–133, 1974.
97. Venkatesh N, Polcyn RE, Norback DH: Metastatic calcification: the role of bone scanning. *Radiology* 129:755–758, 1978.
98. Williamson BRJ, Teates CD, Bray ST: Bone scanning in detecting soft tissue abnormalities. *South Med J* 73:853–862, 1980.
99. Seid K, Lin D, Flowers WM Jr: Intense myocardial uptake of Tc-99m MDP in a case of hypercalcemia. *Clin Nucl Med* 6:565–567, 1981.
100. Chaudhuri TK: Increased hepatic predilection of bone seeking radiopharmaceuticals in patients with hypercalcemia. *Int J Nucl Med Biol* 3:199–200, 1976.
101. Armas R, Neumann R, Goldsmith SJ: Differential skeletal uptake of Tc-99m tagged pyrophosphate and methylene diphosphonate in leukemia. *J Nucl Med* 24:799–802, 1983.
102. Zimmer AM, Pavel DG: Experimental investigations of the possible cause of liver appearance during bone scanning. *Radiology* 126:813–816, 1978.
103. Hakim S, Joo KG, Baeumler GR: Visualization of acute hepatic necrosis with a bone imaging agent. *Clin Nucl Med* 10:697–698, 1985.

CATEGORY A: Unusual Nuclear Medicine Study Results, e.g., Altered Biodistribution and Artifacts

- Hladik WB, Ponto JA, Stathis VJ: Drug-radiopharmaceutical interactions. In Thrall JH, Swanson DP (eds): *Diagnostic Interventions in Nuclear Medicine*. Chicago, Year Book Medical Publishers, 1985, pp 226-246.
- Wells LD, Bernier DR: *Radionuclide Imaging Artifacts*. Chicago, Year Book Medical Publishers, 1980.
- Ryo UY, Bekerman C, Pinsky SM: *Atlas of Nuclear Medicine Artifacts and Variants*. Chicago, Year Book Medical Publishers, 1985.
- Datz FL: *Gamuts in Nuclear Medicine*. Norwalk, CT, Appleton-Century-Crofts, 1983.
- Shaw SM, Faint J: *Factors and Medications Affecting the Distribution of Radiopharmaceuticals in Nuclear Medicine Procedures*. St Louis, Mallinckrodt, 1981.
- Hladik WB, Saha GB, Study KT (eds): *Essentials of Nuclear Medicine Science*. Baltimore, Williams & Wilkins, 1987.
- Swanson DP, Thrall JH, Chilton HM: *Pharmacoradiology*. New York, Macmillan, 1987.
- Iowa Drug Information Service, University of Iowa.

CATEGORY B: Internal Radiation Dosimetry

- Radiopharmaceutical Internal Dose Information Center, Oak Ridge National Laboratories, Oak Ridge, TN. Phone (615)576-3449.
- Coffey JL, Watson EE, Hubner KF, Stabin MG: Radiopharmaceutical absorbed dose considerations. In Hladik WB, Saha GB, Study KT (eds): *Essentials of Nuclear Medicine Science*. Baltimore, Williams & Wilkins, 1987, pp 51-74.
- Section 78:00 (Radiopharmaceuticals). In McEvoy GK, McQuarrie GM (eds): *American Hospital Formulary Service—Drug Information*. Bethesda, MD, American Society of Hospital Pharmacists (monographs will appear beginning in 1987).
- Swanson DP, Thrall JH, Chilton HM: *Pharmacoradiology*. New York, Macmillan, 1987.
- Medical Internal Radiation Dose (MIRD) Pamphlets and MIRD Dose Estimate Reports. New York, Society of Nuclear Medicine (published at unspecified time intervals).
- Cloutier RJ, Watson EE, Coffey JL: Radiopharmaceutical dose calculation. In Harbert J, Da Rocha AFG (eds): *Textbook of Nuclear Medicine*, ed 2, vol 1: *Basic Science*. Philadelphia, Lea & Febiger, 1984, pp 267-282.
- Watson EE, Schlafke-Stelson AT, Coffey JL, Cloutier RJ (eds): *Third International Radiopharmaceutical Dosimetry Symposium*, HHS Publication FDA 81-8166. Rockville, MD, National Center for Devices and Radiological Health, 1981.
- Robertson JS: Radiation dosimetry for internally distributed radionuclides. In Wahner HW (ed): *Nuclear Medicine: Quantitative Procedures*. Boston, Little, Brown, 1983, pp 31-42.
- Product package inserts
- Fullerton GD, et al (eds): Medical Physics Monograph No. 5: Biological Risks of Medical Irradiations. American Institute of Physics, 1980.
- Watson EE, Schlafke-Stelson AT (eds): *Fourth International Radiopharmaceutical Dosimetry Symposium*. Oak Ridge, TN, Oak Ridge Associated Universities, 1986.

CATEGORY C: Use of Interventional Drugs in Nuclear Medicine

- Thrall JH, Swanson DP (eds): *Diagnostic Interventions in Nuclear Medicine*. Chicago, Year Book Medical Publishers, 1985.
- Spencer RP (ed): *Interventional Nuclear Medicine*. New York, Grune & Stratton, 1984.
- Ponto JA, Hladik WB: Common uses of nonradioactive drugs in nuclear medicine. *Am J Hosp Pharm* 41:1189-1193, 1984.
- Thrall JH, Swanson DP: Interventional aspects of nuclear medicine. In Freeman LM, Weissman HS (eds): *Nuclear Medicine Annual*. New York, Raven Press, 1983, pp 1-49.
- Saha GB, Swanson DP, Hladik WB: Interventional studies in nuclear medicine. In Hladik WB, Saha GB, Study KT (eds): *Essentials of Nuclear Medicine Science*. Baltimore, Williams & Wilkins, 1987, pp 115-132.

CATEGORY D: Pediatric Radiopharmaceutical Doses

- Bekerman C, Conway JJ, Pinsky SM, Weiss SC (eds): *Manual of Pediatric and Unusual Nuclear Medicine Procedures*. Crystal Lake, IL, Central Chapter, Society of Nuclear Medicine, 1979.
- Day KE: Method for calculating pediatric radioactive doses. In: *Transient Equilibrium*. ER Squibb & Sons, Hospital Division, January 1977, pp 1-2.
- Sty JR, Starshak RJ, Miller JH: *Pediatric Nuclear Medicine*. Norwalk, CT, Appleton-Century-Crofts, 1983.
- Siddiqui AR: *Nuclear Imaging in Pediatrics*. Chicago, Year Book Medical Publishers, 1985.

- Treves ST: *Pediatric Nuclear Medicine*. New York, Springer-Verlag, 1985.
- Levine G, Mazzetti C, Mahli B: A methodology for preparing pediatric doses of Tc-99m MAA for pulmonary perfusion studies. *J Nucl Med Technol* 8:94-96, 1980.
- Subcommittee on Pediatric Dosing, FDA Radiopharmaceutical Drug Advisory Committee.
- Shore RM, Hendee WR: Radiopharmaceutical dosage selection for pediatric nuclear medicine. *J Nucl Med* 27:287-298, 1986.

CATEGORY E: Adverse Reactions to Radiopharmaceuticals

- Cordova MA, Hladik WB, Rhodes BA, Atkins HL: Adverse reactions associated with radiopharmaceuticals. In Hladik WB, Saha GB, Study KT (eds): *Essentials of Nuclear Medicine Science*. Baltimore, Williams & Wilkins, 1987, pp 303-320.
- Swanson DP, Thrall JM, Chilton HM (eds): *Pharmacoradiology*. New York, Macmillan, 1987.
- Cordova MA, Hladik WB, Rhodes BA: Validation and characterization of adverse reactions to radiopharmaceuticals. *Noninvasive Med Imaging* 1:17-24, 1984.
- Food and Drug Administration, Division of Drug and Biological Product Experience.
- Volunteer Reporting System sponsored by SNM, USP, FDA (Form FDA 1639): Contact the chairman of the Society of Nuclear Medicine Subcommittee on Adverse Reactions.
- Mandatory Reporting System required of drug sponsor (Form FDA 1639): Contact regulatory affairs division of drug manufacturer.

CATEGORY F: Clinical Studies Documenting Safety and Efficacy

- Computer searches of primary literature.
- Iowa Drug Information Service, University of Iowa.

CATEGORY G: Specific Physicochemical, Pharmaceutical, or Kinetic Properties of Radiopharmaceuticals

- Spencer RP (ed): *Radiopharmaceuticals: Structure-Activity Relationships*. New York, Grune & Stratton, 1981.
- Colombetti LG (ed-in-chief): CRC series on Radiotracers in Biology and Medicine (9 titles). Boca Raton, FL, CRC Press, 1982.
- Freeman LM (ed): *Freeman and Johnson's Clinical Radionuclide Imaging*, ed 3. New York, Grune & Stratton, 1984.
- Section 78:00 (Radiopharmaceuticals). In McEvoy GK, McQuarrie GM (eds): *American Hospital Formulary Service—Drug Information*. Bethesda, MD, American Society of Hospital Pharmacists (monographs will appear beginning in 1987).
- Swanson DP, Thrall JH, Chilton HM (eds): *Pharmacoradiology*. New York, Macmillan, 1987.
- Saha GB: *Fundamentals of Nuclear Pharmacy*, ed 2. New York, Springer-Verlag, 1984.
- Phan T, Wasnich R: *Practical Nuclear Pharmacy*, ed 2. Honolulu, Banyan Enterprises, 1981.
- Deutsch E, Nicolini M, Wagner HN Jr (eds): *Technetium in Chemistry and Nuclear Medicine*. New York, Raven Press, 1983.
- Eckelman WC, Coursey BM (eds): Technetium-99m: generators, chemistry, and preparation of radiopharmaceuticals. *Int J Appl Radiat Isot* 33(10): October 1982 (entire issue).
- Heindel ND, Burns HD, Honda T, Brady LW (eds): *The Chemistry of Radiopharmaceuticals*. New York, Masson Publishing, 1978.
- Billinghurst MW, Fritzberg AF: *Chemistry for Nuclear Medicine*. Chicago, Year Book Medical Publishers, 1981.
- Eckelman WC: Radiopharmaceutical chemistry. In Harbert J, Da Rocha AFG (eds): *Textbook of Nuclear Medicine*, ed 2, vol 1: *Basic Science*. Philadelphia, Lea & Febiger, 1984, pp 212-266.
- Rhodes BA (ed): *Quality Control in Nuclear Medicine*. St Louis, CV Mosby, 1977.
- Workshop Manual for Radionuclide Handling and Radiopharmaceutical Quality Assurance*. HHS Publications FDA 82-8101, Rockville, MD, National Center for Devices and Radiological Health, 1982.
- Robbins PJ: *Chromatography of Technetium-99m Radiopharmaceuticals—A Practical Guide*. New York, Society of Nuclear Medicine, 1984.
- Hamilton DR, Herrera NE, Paras P, Rollo FD, MacIntyre WJ (eds): *Quality Assurance in Nuclear Medicine*. Proceedings of an International Symposium and Workshop. HHS Publication FDA 84-8224. Rockville, MD, National Center for Devices and Radiological Health, 1984.
- Kristensen K: *Preparation and Control of Radiopharmaceuticals in Hospitals*. Vienna, International Atomic Energy Agency, 1979.

CATEGORY H: Formulation, Preparation, and Quality Assurance of Radiopharmaceuticals (See Category G)

CATEGORY I: Regulatory Requirements

1. Kristensen K, Norbygaard E (eds): *Safety and Efficacy of Radiopharmaceuticals*. Boston, Martinus Nijhoff Publishers, 1984.
2. US Code of Federal Regulations Titles 10, 21, and 49.
3. Robertson JS: Interaction with control agencies. In Wahner HW (ed): *Nuclear Medicine: Quantitative Procedures*. Boston, Little, Brown, 1983, pp 43-85.
4. Vandergrift JF: Regulatory problems in nuclear medicine. In Hladik WB, Saha GB, Study KT (eds): *Essentials of Nuclear Medicine Science*. Baltimore, Williams & Wilkins, 1987, pp 321-330.
5. Swanson DP, Lieto RP: The submission of IND applications for radiopharmaceutical research: when and why. *J Nucl Med* 25:714-719. 1984.
6. Levine G, Abel N: Considerations in the assembly and submission of the physician-sponsored investigational new drug application. In Hladik WB, Saha GB, Study KT (eds): *Essentials of Nuclear Medicine Science*. Baltimore, Williams & Wilkins, 1987, pp 357-386.
7. Friedman BE, Hladik WB (eds): *Regulation and Inspection of Nuclear Pharmacies*. Albuquerque, University of New Mexico College of Pharmacy, 1982.

Appendix 24.1—continued

1. *Acta Radiologica: Diagnosis*
2. *Acta Radiologica: Oncology, Radiation, Physics, Biology*
3. *Acta Radiologica Supplementum*
4. *AJR. American Journal of Roentgenology*
5. *Annales de Radiologie*
6. *Applied Radiology*
7. *British Journal of Radiology*
8. *Cardiovascular and Interventional Radiology*
9. *Clinical Nuclear Medicine*
10. *Clinical Radiology*
11. *CRC Critical Reviews in Diagnostic Imaging*
12. *Diagnostic Imaging in Clinical Medicine*
13. *European Journal of Nuclear Medicine*
14. *Gastrointestinal Radiology*
15. *Health Physics*
16. *International Journal of Applied Radiation and Isotopes*
17. *International Journal of Nuclear Medicine and Biology*
18. *International Journal of Radiation Biology and Related Studies in Physics, Chemistry, and Medicine*
19. *International Journal of Radiation Oncology, Biology, Physics*
20. *Investigative Radiology*
21. *Journal Belge de Radiologie*
22. *Journal of Labelled Compounds and Radiopharmaceuticals*
23. *Journal of Laboratory and Clinical Medicine*
24. *Journal of Nuclear Medicine*
25. *Journal of Nuclear Medicine and Allied Sciences*
26. *Journal of Nuclear Medicine Technology*
27. *Journal of Radiation Research*
28. *Journal de Radiologie*
29. *Kaku Igaku*
30. *Nuclear Medicine Communications*
31. *Nuklearmedizin*
32. *Pediatric Radiology*
33. *Polski Przegląd Radiologii i Medycyny Nuklearnej*
34. *Progress in Nuclear Medicine*
35. *Radiation and Environmental Biophysics*
36. *Radiation Medicine*
37. *Radiation Research*
38. *Radioactive Isotopes in Clinical Medicine*
39. *Radiobiologia, Radiotherapia*
40. *Radiobiologia*
41. *Radioisotopes*
42. *Radiologe*
43. *Radiologia Diagnostica*
44. *Radiologia Medica*
45. *Radiologic Clinics of North America*
46. *Radiology*
47. *ROEFE: Fortschritte auf dem Gebiete der Roentgenstrahlen und der Nuklearmedizin*
48. *Recent Advances in Clinical Nuclear Medicine*
49. *Recent Advances in Nuclear Medicine*
50. *Seminars in Nuclear Medicine*
51. *Urologic Radiology*
52. *Vestnik Rentgenologii Radiologii*

Appendix 24.2. Selected journals that may include articles pertaining to the topics of nuclear medicine and radiopharmaceuticals.

25

Issues of Patient Education

Donald A. Bille

Patient education is not a new field in health care. Today, however, greater emphasis is being placed on delivering organized, systematic patient education as an integral entity within the health care system rather than as a haphazard, episodic, fragmented occurrence (1, 2). Health care organizations and the various health care disciplines are examining their role in educating the many clients they serve. This self-examination may be initiated by consumer demands, by new or more stringent standards of care, or by attempts to market health care services to the public.

Patient education can be defined as a "systematic, planned, learning experience, based on an individual's needs[,] that results in a change of behavior with the goal of promotion and maintenance of optimal health" (3). One is hard pressed to find, however, a model patient education program. A review of the literature reveals that many articles have been published describing various aspects of patient education as an integral component of comprehensive health care. In the nuclear medicine literature, however, only a few scattered articles on the topic of patient education are available (4, 5).

Results of interviews with physicians and technicians in several nuclear medicine departments indicate that there is no model for patient education but that patient education stems directly from questions and answers between the technician and the patient. Thus patient education stems from the individual department and is not a systematically planned activity.

PATIENT'S RIGHT TO KNOW

Human beings in the United States are endowed with the "right to self-determination." This basic right, when applied to patient care,

means that the patient should receive enough information concerning proposed treatment to make a reasoned, informed choice to accept or reject the recommended care. The patient, then, has the right to determine whether or not he or she will submit to a nuclear medicine procedure and needs to know enough information about that procedure to make an informed decision.

Various members of the health care team (i.e., physicians, nurses, technicians, etc.) should share in the patient education process. As pointed out by the American Hospital Association, however, the physician bears accountability for the patient's informed consent. The American Hospital Association in 1972 published "A Patient's Bill of Rights." One of the twelve rights in this document (6) states:

"The patient has the right to receive from his physician information necessary to give informed consent prior to the start of any procedures and/or treatment. Except in emergencies, such information for informed consent should include but not necessarily be limited to the specific procedure and/or treatment, the medically significant risks involved, and the probable duration of incapacitation. Where medically significant alternatives for care or treatment exist, or when the patient requests information concerning medical alternatives, the patient has the right to such information."

This "Bill of Rights" clearly states that it is the physician's responsibility to inform the patient about any procedures being ordered. It may be implied that the patient's own attending physician, responsible for ordering nuclear medicine procedures, bears the main responsibility for informing the patient about these pro-

cedures. It would be wise practice, however, for the physician and technician performing the nuclear medicine procedure to determine the extent of the patient's understanding prior to initiating the procedure. Failure to inform the patient properly could result in litigation, and all health care personnel associated with that patient's care must share in the responsibility to obtain an informed consent.

Since most hospitals hold membership in the American Hospital Association, the "Bill of Rights" may be seen as a standard of care to be achieved in member institutions. Nevertheless, some physicians fear that patient education will make malpractice litigation worse (7): "The more patients know, the more likely they are to find something to sue about." Actually, malpractice experts state that lack of rapport is a major cause of malpractice. Making the effort to help the patient understand his or her illness should decrease the incidence of malpractice suits."

Professional organizations, then, have responded to the patient's right to informed consent by bureaucratically addressing the issue of patient education. These same organizations, however, have done little to assist health care professionals in identifying proper approaches to patient education.

THEORETICAL APPROACHES TO PATIENT EDUCATION

Principles of teaching and learning have been known for many years. Current research, however, indicates that a pedagogical approach may not be appropriate for adults, especially when that adult is faced with the stressors of illness and/or hospitalization. Within the past decade, research on the patient as a learner has been carried out (8-10). Results of this research indicate the need to incorporate several principles of adult education into the process of patient education, which include: (a) teach the patient what he or she wants to learn, (b) build on a knowledge base, (c) achieve physical readiness to learn, (d) allow the patient to participate in the teaching-learning process, (e) obtain feedback on learning outcomes, (f) adjust presentation of information to the patient's level, and (g) promote a warm interpersonal relationship.

Teach What the Patient Wants to Learn

The ideal place to begin the patient's teaching-learning process is in the identification of questions that the patient may have concerning the nuclear medicine procedure. Once a basic explanation of the procedure and the reason the patient needs that procedure have been provided by the attending physician, the patient should be asked, "What questions do you have concerning this procedure?" Once the patient has identified any questions he or she may have about the procedure, explanations to answer these questions can be provided. Further information about the procedure should be withheld until all of the patient's own questions have been answered, since the patient may not be able to concentrate on any other information until the questions uppermost in his or her mind have been answered. When these questions have been answered, the technologist can provide a clear explanation of exactly what will happen to the patient during the procedure. Once this explanation has been provided, the patient should be asked again whether he or she has any questions, and any questions that surface should be answered honestly and in a simple language.

Build on a Knowledge Base

Adults learn best when content to be learned is presented in relation to what they already know. Most adults have undergone an x-ray examination at some time in their life. Thus, most patients already know that pictures are being taken during the procedure and that a certain amount of radiation will be used. As the result of the media (especially television and newspapers) and knowledge of such events as "Three Mile Island," however, patients often associate the word "nuclear" with harmful radiation and even cancer. The exact nature of the patient's knowledge about radiation and their feelings about it need to be determined. Patients often ask such questions as "How long will the radioactive material stay in me?", "Will radioactivity harm me?", and "Can I be around other people after I have been injected with the radioactive material?"

Patients are often already aware of how little time is involved in taking an x-ray. Thus, information needs to be provided to help the patient

understand how nuclear medicine procedures differ from x-rays, including the fact that nuclear medicine procedures involve injection of a radioactive substance, that time is required to allow the injected material to reach the target organ, and that the total time involved in the procedure will be about an hour.

Achieve Physical Readiness to Learn

Humans learn most effectively and efficiently when they are physically healthy, well rested, and physically comfortable. This may present a dilemma for patient education, since the exact opposite conditions often are the norm. Patients may be in pain, and thus their attention span will be shortened and the level at which they can understand material being presented will be lowered. Electrolyte imbalances may interfere with the ability to understand clearly, and certain medications being given to the patient (especially those with neurologically related effects) may interfere with his or her ability to learn.

Before beginning a teaching-learning interaction with the patient, the technologist should ascertain the patient's level of comfort. Whether the patient is seated or is lying in bed, his or her position should be relaxed and comfortable. Attention to room temperature is important, since a lack of comfort from being chilled or too warm may interfere with the patient's ability to pay attention to the material being presented. The room in which teaching occurs should be well lighted, and distractions (such as noise and the movement of patients or personnel through the area) should be minimized if not eliminated.

Allow the Patient to Participate in the Teaching-Learning Process

Use of the traditional pedagogical approach, in which the learner is subjected to passively listening to a lecture, seldom achieves optimal results in patient education. The adult learner needs to be actively involved in both determining what is to be learned and in the presentation of that material.

Patient education often is less effective than is intended because health care professionals teach what *they* think is important, not what the patient thinks is important. Thus, one of the first

steps in the teaching-learning process should be to allow the patient to determine what he or she needs to learn. This requires that each patient-teaching interaction be individualized, which often places some burden on the busy health care professional. Standardized teaching programs, with established objectives and content, may not be as effective in patient teaching as they are in colleges or universities. Thus, if the nuclear medicine department is trying to systematize its patient education activities, guidelines for information to be given patients can be helpful in organizing the technologist's approach to patient education, but these guidelines should not be seen as being engraved in stone. The patient's own concerns should be dealt with first, and individual learning needs should be determined prior to launching into a presentation of standardized content.

Participation in the teaching-learning process is also achieved through the involvement of the patient's various senses. Hearing is the body's most passive sense. Thus, a teaching-learning interaction which is primarily a lecture will not achieve the most efficient learning outcomes for the patient. Verbal information being presented to the patient should be emphasized by visual stimulation. This can be accomplished through the use of photographs, simple drawings or illustrations, and even a demonstration of what it is that is being discussed. Allowing the patient a chance to touch the equipment before being subjected to the procedure is often helpful in gaining their understanding as well as in allaying their fears and anxieties.

Obtain Feedback on Learning Outcomes

Each teaching-learning interaction should be evaluated to determine the level of the patient's understanding. It is not enough to ask the patient, "Do you understand?"; many patients will be too embarrassed to admit that they do not.

Feedback may be obtained by asking the patient a specific question that is prefaced with an explanation, such as "I want to be sure you understand what it is that we are going to do. Please tell me what your lung scan will involve?," or "Tell me what you understand about the radioactive substance that I will be

injecting?" Although this may seem redundant to the busy technologist, it is the only way that true feedback on learning can be obtained.

Once the patient has provided feedback on what he or she had learned, the technologist can fill in the gaps in understanding by repeating information that the patient has missed or by correcting information that the patient has misunderstood. Feedback is then again obtained, and the process repeated, until the patient understands enough information about the procedure to give "informed" consent.

Adjust the Presentation to the Patient's Level

Since the ability of patients to learn varies, the technologist teaching patients about nuclear medicine procedures must approach the patient at an appropriate level, and present material at an appropriate rate, to insure optimal learning outcomes.

Health care professionals should not fall into the trap of assuming that the level of formal education of a patient is related to the patient's ability to learn the material being presented. Fear, anxiety, less-than-optimal physical condition, and other circumstances limit the patient's ability to learn. Thus, even the patient who has a college education may not be able to learn what is being taught if the material is presented too technically or too quickly.

Patient education often makes use of printed materials to supplement what is being taught. For instance, several booklets for patient education are available from Mallinckrodt Nuclear (11-15) and the Society of Nuclear Medicine (16, 17). These booklets contain text and cartoons designed to provide "answers to the questions most commonly asked by patients." The nuclear medicine technologist should be aware of two facts prior to using these booklets or any other printed media for patient education. First, a large segment of the population does not know how to read. Even in the United States where there is relatively easy access to education, many people are functionally illiterate. Patients often are too embarrassed to admit that they do not know how to read, and therefore, the technologist may be lulled into a false sense of security once a booklet is given to the patient.

This author uses the following approach when it is unknown whether or not the patient is able to read: The booklet or brochure is handed to the patient upside down; if the patient looks at the material while continuing to hold it upside down, he or she does not know how to read.

Second, even if a patient knows how to read, the level of understanding of what is being read may not be very high. The average reading ability of people in the United States is the sixth grade level (this is the level at which the average daily newspaper is written). A survey done by this author indicates that many patient education materials are written at a much higher level than can be understood by patients. For instance, the "average" consent for surgical procedures form is written at about the seventeenth grade level (first year of graduate school) or at about the level of the *New England Journal of Medicine*.

A recommendation that makes a great deal of sense for the technologist who wishes to use printed media is to have the material read by a grade school student (especially a sixth or seventh grader). If that student can understand the material, the "average" patient should be able to understand it.

Promote a Warm Interpersonal Relationship

Good rapport with patients, as has been pointed out, is a means to decrease the incidence of malpractice suits. A warm rapport with the patient also enhances the learning outcome.

The patient who is anxious or fearful will respond to warmth and understanding by relaxing and by exploring those fears and anxieties. The technologist should not give the impression of being in a hurry to explain the nuclear medicine procedure. The comfort the patient receives through the warmth and rapport of the technologist will not only help the patient achieve a greater level of understanding but will also help the technologist achieve better patient cooperation throughout the procedure. With this cooperation, more than the amount of time it took to provide a careful explanation of the procedure can often be gained.

Patient education can be a time-consuming activity that adds a burden to the already-busy nuclear medicine technologist. If these previously discussed principles of patient education

are followed, however, learning outcomes can be achieved, resulting in a more satisfied patient, a more effective procedural result, and less likelihood of an unpleasant experience for the patient and the technologist.

PATIENT EDUCATION: A TEAM EFFORT

It is the patient who initiates the entry into the health care system. This initiative occurs in the form of choosing a personal physician and then visiting that physician when the patient becomes aware of the need. From then on, the patient is subjected to contact with many other health care professionals. When a nuclear medicine procedure is required, the patient may be treated as an outpatient (in which case the nuclear medicine health care team has sole responsibility for teaching and caring for the patient) or as an inpatient (in which case many other health care team members come into contact with the patient). In each situation, the patient requires information and receives that information from many sources.

The team approach to patient education requires coordination and communication in order to assure continuity, not only in the care of the patient but also in the teaching-learning process. All members of the health care team need to coordinate their activities, especially the content that they teach the patient, in order to eliminate unnecessary duplication. This same coordination will eliminate contradictions and conflicting information. One person may teach one thing to the patient, and someone else may teach a different piece of information which may seem contradictory to the patient.

Communication centered around the individual patient and patient education, in general, need to be ongoing. Many health care professionals (such as staff physicians, professional nurses, etc.) have no awareness of what actually takes place during a nuclear medicine procedure. Therefore, it behooves every health care institution that performs nuclear medicine procedures to provide in-service education programs for all personnel who have contact with the patient. These in-service presentations should include at least the following information:

1. Specific nuclear medicine procedures:
 - What actually happens in the nuclear medicine department. Information concerning the injection of radioactive substances. Patient care measures that may be necessary before, during, and after a nuclear medicine procedure.
2. Interviewing skills—to assist in determining the patient's level of knowledge and understanding.
3. Roles and responsibilities of various nuclear medicine health care team members.
4. Teaching-learning principles:
 - How to teach.
 - What to teach.
5. Communication skills.
6. Evaluation skills—to determine the extent of learning.

Once an in-service presentation has been made, it will be important for the staff (in both the nuclear medicine department and the rest of the institution) to receive positive reinforcement. When a patient who is undergoing a nuclear medicine procedure appears for the scheduled examination and is well prepared for that examination (informed consent already exists), the staff who provided this information should be given feedback and reinforcement concerning their success. The staff's perception of their role in patient education will thereby be enhanced.

The success of patient education activities can be insured by involvement of all staff members in planning for, implementing, and evaluating patient education outcomes. Successful patient education cannot be accomplished by only one of the disciplines working on the nuclear medicine health care team. Therefore, each discipline must be represented when patient education is being discussed.

Patient education must be seen as an expectation of every person's job performance. The manager or administrator of the nuclear medicine department must hold each member of the staff accountable for their part in the patient education process. Once again, reinforcement should be given when positive results are obtained, thereby increasing the staff's awareness of the importance of patient education activities.

DIRECTIONS FOR THE FUTURE

Research has shown that patients want to learn about, and understand, not only their conditions but also those procedures that they have to undergo. Research has also shown that patients learn differently than do healthy people, because of fears, anxieties, or other factors associated with their illness.

The future for patient education has infinite possibilities. Nuclear medicine professionals should consider conducting research on patients who are undergoing nuclear medicine procedures. This research could serve to identify what type of and how much information these patients want or need to learn. Research could identify factors present in hospitalization (or in being an outpatient) that limit patients' abilities to understand what is being taught.

Quality assurance will take on more importance not only as third-party reimbursers look to the quality of care they can or will pay for but also as consumers of health care become more aware of their rights as patients. The Joint Commission on Accreditation of Hospitals (JCAH), in their latest standards for quality assurance, recommend that quality assurance be organized as a hospital-wide activity. Such important components of quality assurance as safety and risk management, education, and clinical monitoring are associated with patient education activities. Issues concerning informed consent, the actual procedures carried out, and the patient's understanding of the procedures and health care must be examined in the light of assuring delivery of quality care.

Educational preparation of the health care professionals also has implications for the future. As technology and the body of scientific knowledge increase within medicine (and all health care professions), these health care practitioners must remain up-to-date in their knowledge and skills. Continuing education is seen as a way to prevent professional obsolescence and to assure quality care. It would be ideal if every health care professional's basic (or continuing) education included experiencing "one of everything" that a patient has to undergo. This, however, would not be practical or feasible. It should suffice to try to increase the health care

professional's awareness of what it is that the patient experiences during illness, whether or not it requires hospitalization.

SUMMARY

Patient education is an important, integral component of comprehensive patient care. Regardless of whether a patient is acutely ill or is merely undergoing a nuclear medicine procedure as a health maintenance activity, patient education activities will help that patient understand what is about to happen as well as what the patient can do to cooperate and make the procedure more effective.

Illness as well as factors inherent in hospitalization may hinder the patient's ability to learn. By paying attention to certain adult education principles, the nuclear medicine health care team member can do much to insure the quality of the nuclear medicine procedure—quality results from the procedure as well as a well-informed satisfied patient.

ACKNOWLEDGMENTS

The author gratefully acknowledges the input of Michael Shannon, M.D., in development of this manuscript.

REFERENCES

1. Breckon DJ: Highlights in the evolution of hospital-based patient education programs, *J Allied Health* 5:35, 1976.
2. Lee EA, Garvey JL: How is inpatient education being managed? *Hospitals* 51:75, 1977.
3. Fylling CP: A comprehensive system of patient education: guidelines for development. In Bille DA (ed): *Practical Approaches to Patient Teaching*. Boston, Little, Brown, 1981, p 16.
4. Bassett CE: Care of the patient in the x-ray department. *Can J Radiog Radiother Nucl Med* 10:43-44, 1979.
5. Bubb D: Teaching patients about ultrasound and CAT brain scans. *Am J Nurs* 44(12):64-65, December 1981.
6. American Hospital Association: "A Patient's Bill of Rights." Chicago, American Hospital Association, 1972.
7. Thompson RE: Obtaining physician support. In Bille DA (ed): *Practical Approaches to Patient Teaching*. Boston, Little, Brown, 1981, p 222.
8. Bille DA: Patients' knowledge and compliance with posthospitalization prescriptions as related to body image and teaching format. Ph.D. dissertation, University of Wisconsin-Madison, 1975.
9. Knowles M: *The Adult Learner: A Neglected Species*, ed 2. Houston, Gulf Publishing, 1973.

10. Rosenberg SG: Patient education: an educator's view. In Somers AR (ed): *Promoting Health: Consumer Education and National Policy*. Germantown, MD, Aspen Systems, 1976, pp 94-95
11. Bruer M: *What You Can Expect from Your Thyroid Uptakes and Scans*. St Louis, Mallinckrodt Nuclear, 1972.*
12. Bruer M: *What You Can Expect from Your Lung Scan*. St Louis, Mallinckrodt Nuclear, 1972, 1977.*
13. Bruer M: *What You Can Expect from Your Brain Scan*. St Louis, Mallinckrodt Nuclear, 1972.*
14. Bruer M: *What You Can Expect from Your Bone Scan*. St Louis, Mallinckrodt Nuclear, 1976.*
15. Bruer M: *What You Can Expect from Your Liver Scan*. St Louis, Mallinckrodt Nuclear, 1972, 1978.*
16. *A Patient's Guide to Nuclear Medicine*. New York, Society of Nuclear Medicine (no year given).
17. *Guidelines for Patients Receiving Radioiodide Treatment*. New York, Society of Nuclear Medicine (no year given).

* Available through the Mallinckrodt Nuclear representatives or from Mallinckrodt Nuclear, St Louis, MO 63134.

26

*Patient Preparation for Nuclear Medicine Studies**

Victor J. Stathis, Doyle W. Cantrell, and Teresa J. Cantrell

In order to optimize the useful information derived from a nuclear medicine study, the potential difficulties associated with each procedure must be addressed. The patient, when considered as one of several variable parameters in the study, represents a possible source of complications. A patient's anatomical and physiologic characteristics and his or her mental and emotional condition at the time of the study can be reflected in the procedure's results. Additionally, limitations and peculiarities of the radiotracer utilized in the study can affect the outcome.

Drug and patient influences, when not directly associated with the organ system or disease process being evaluated, can diminish the validity and usefulness of the information derived from a nuclear medicine study. Therefore, each patient should be prepared for their particular procedure so that inherent potential interferences are minimized.

There are several preparatory procedures which can be useful in most situations. One of the simplest forms of preparation, and perhaps one of the most important, is explaining to the patient what type of procedure he or she is having, why it is necessary, and exactly what will be involved in the process. Enhancing a patient's understanding of the procedure helps to develop rapport between the patient and the

professional. This rapport will encourage patient cooperation, which is necessary for the successful completion of the study (refer to Chapter 25).

To obtain the patient's drug history, when possible, is useful. Many pharmaceutical-radio-pharmaceutical interactions have been described in the literature (1-4). Drug effects can interfere with interpretation of the scan, especially when the nuclear medicine staff is not aware of the patient's medication regimen (refer to Chapters 13 and 14).

Patient counseling and the obtaining of a drug history are two examples of preparation which can be applied to most patients and will be of benefit in almost every type of nuclear medicine procedure. In order to maximize the amount of useful information derived from a study, however, it may be necessary to take additional preparatory steps that are specific to the patient group or to the study being performed. This chapter focuses on these additional patient preparation procedures.

With regard to purposeful pharmacologic intervention in nuclear medicine studies, it is noteworthy that only those practices which facilitate performance of the procedure or minimize interfering influences are described. That is, pharmaceuticals are discussed only with regard to how they are used in patient preparation to overcome inherent radiopharmaceutical distribution problems or patient limitations. The reader is referred to Chapter 10 for a description of procedures in which pharmaceuticals are used to derive additional or more specific information from nuclear medicine studies.

*Although [^{99m}Tc]pertechnetate, [⁶⁷Ga]gallium citrate, and [²⁰¹Tl]thallous chloride are preferred by IUPAC, ^{99m}Tc-pertechnetate, ⁶⁷Ga-citrate, and ²⁰¹Tl-chloride are standard, and all are used throughout this chapter.

PEDIATRIC STUDIES

The pediatric patient often requires special preparation. Cooperation may be difficult to obtain but can be maximized through the application of concerted interest and interpersonal communication skills. These efforts must be directed toward patient and parent alike. Parental support can contribute greatly to the success of the procedure.

In pediatric nuclear medicine, patient immobilization is usually a significant practical challenge. One approach is the use of sandbags to maintain the patient in position (5). If the bags are only partially filled, they may be molded somewhat to the desired shape and are not as likely to roll off the table top. Restraint with sheets or towels and simple manual immobilization have been used also (6).

Restraint methods may be inadequate when the pediatric patient is very active or agitated. Sedation may be necessary. Any one of several sedative-hypnotic agents can be used (6-8). Chloral hydrate (50 mg/kg; maximum single dose is 1 g) appears to work well in most patients and can be administered as an oral liquid or in suppository form (5).

Before any type of sedative is administered, consultation with the referring physician is necessary. The patient may be receiving sedative medication or drugs with sedative effects. Also, some children exhibit idiosyncratic reactions to sedatives, ranging from excessive central nervous system depression to extreme agitation (9). Occasionally, stronger sedatives or larger doses may be needed. The referring physician must be consulted.

THYROID UPTAKE AND IMAGING

Obtaining a patient's drug history prior to nuclear medicine studies that elevate thyroid function or structure is especially important, since many pharmacologic agents can interfere with the thyroidal uptake of radioactive tracers. For example, drugs that contain large amounts of iodine inhibit thyroidal concentration of radioiodinated pharmaceuticals (10). It is postulated that this effect is due to radiotracer dilution.

When the amount of nonradioactive iodide in the vascular pool is elevated (e.g., by iodine ingestion), the quantity of radioiodinated tracer present represents a smaller fraction of the body's iodide pool. Consequently, the greater portion of iodide concentrated by the thyroid gland will be of nonradioactive type. Tracer uptake will be minimal (1).

The patient should be questioned regarding the following types of products:

- Lugol's solution, saturated solution of potassium iodide (SSKI), and other iodine preparations
- Vitamin and mineral supplements
- Topical iodides (e.g., Betadine)
- Radiological contrast media
- Iodide-containing antitussives or expectorants

Other pharmacologic agents can also influence radiotracer uptake. Any drug that alters the thyroid gland's uptake, organification, deiodination, or secretion mechanisms can interfere with nuclear medicine thyroid studies or therapeutic procedures. There is an enormous amount of data regarding drug-induced alterations in the biodistribution of thyroid imaging agents. The subject is addressed in both general and specific reviews (1-4, 10-18) and in Chapter 14. The patient should be screened by the nuclear medicine staff as to the following types of medications:

- Natural or synthetic thyroid hormones
- Antithyroid medications
- Salicylates
- Adrenal (and gonadal) steroids
- Sulfonamides, sulfonyleureas
- Phenylbutazone
- Nitroprusside

[^{99m}Tc]pertechnetate thyroid scans can also be influenced by pharmacologic agents. Unlike radioiodides, pertechnetate is not organified by the thyroid. Technetium is transported from the bloodstream into the thyroid but is not used by the gland in the production of thyroid hormones (19, 20). Therefore, drugs that influence uptake will affect pertechnetate biodistribution, whereas those that alter hormone synthesis (e.g., propylthiouracil) will not.

NONTHYROID STUDIES WITH RADIOIODINATED PHARMACEUTICALS

Radioiodinated pharmaceuticals are utilized in several nonthyroidal nuclear medicine procedures. In these studies, it often is advantageous to inhibit uptake of unbound radioiodide by the thyroid gland. Thyroid blockade, with 30-130 mg of potassium iodide per day (usually as Lugol's solution or SSKI) prior to the procedure, encourages excretion of unbound radioactive iodide (21-23). This decreases background radioactivity and, especially when ¹³¹I is used, reduces the radiation dose to the patient (24). Thyroidal radioiodine uptake suppression can be initiated 24-48 hours prior to the study and may be continued for several days afterward (25, 26).

Thyroid blockade immediately prior to the study usually is the most practical method and generally is effective. It is not necessary to begin blockade earlier. In fact, iodide administered as late as 6 hours after radioiodine intake has been shown to suppress in excess of 90% of normal thyroid uptake function (22, 23).

As an alternative to iodide, anions such as perchlorate or thiocyanate can be used to inhibit thyroid concentration of radioiodine or pertechnetate. Potassium perchlorate usually is administered for this purpose. These ions act as competitive inhibitors of the thyroid gland's transport mechanism (27-28). Thyroid blockade usually is included in the preparation of patients for:

- ¹²⁵I-labeled fibrinogen uptake studies
- ¹²⁵I or ¹³¹I in RISA plasma studies
- [¹³¹I]iodomethylnorcholesterol (NP-59) adrenal imaging
- m-[¹³¹I]iodobenzylguanidine (mIBG) imaging
- ¹³¹I-oleic acid or triolein absorption studies

BONE STUDIES (^{99m}Tc-LABELED PHOSPHATES AND PHOSPHONATES)

Approximately 50% of an injected ^{99m}Tc bone-localizing agent normally deposits onto osseous tissue. The other 50% of the administered dose undergoes renal excretion (29-31).

The excreted radioactivity which accumulates in the urinary bladder can hinder visualization of bony structures in the pelvic region (32, 33).

In order for interference resulting from the presence of radioactivity in the bladder to be minimized, the patient should void prior to the scanning procedure. Ingestion of fluids during the time between radionuclide injection and imaging will stimulate the micturition reflex (34, 35). This procedure should also minimize the radiation dose to the urinary bladder by decreasing the residence time of radioactivity in the bladder.

BRAIN AND CEREBRAL PERFUSION STUDIES (^{99m}Tc-PERTECHNETATE, ^{99m}Tc-DIETHYLENTRIAMINEPENTAACETIC ACID (DTPA), ^{99m}Tc-GLUCEPTATE)

When ^{99m}Tc-pertechnetate is used for brain imaging or cerebral perfusion studies, the patient should receive 200-400 mg of potassium perchlorate prior to the study. This drug inhibits uptake of radiopertechnetate by the choroid plexus. Radioactivity present in the choroid plexus can interfere with interpretation of the scan (36-37). Perchlorate usually is administered in oral liquid or capsule form 10-30 minutes before pertechnetate administration. There is evidence, however, that the choroid plexus will be blocked even when oral perchlorate and intravenously administered ^{99m}Tc-pertechnetate are given simultaneously (38). If a liquid preparation of perchlorate is used, the patient should be advised that the taste may be slightly objectionable. The taste has sometimes been described as stale or salty.

Because pertechnetate is also concentrated by the salivary glands, it may be advisable to premedicate the patient with 0.4 mg of atropine sulfate to inhibit saliva production (19, 20, 39). If the patient is not premedicated, vertex views of the brain may be difficult to interpret because of the presence of radioactive saliva in the facial area.

Perchlorate and atropine are not required when ^{99m}Tc-DTPA or ^{99m}Tc-gluceptate are used

for scintigraphic brain studies. These two radiotracers are not noticeably concentrated by the choroid plexus or salivary glands and, therefore, are an alternative to radiopertechnetate in patients who may have difficulty ingesting perchlorate (38).

TUMOR AND ABSCESS LOCALIZATION ([⁶⁷Ga]GALLIUM CITRATE)

The excretion of ⁶⁷Ga-citrate is a relatively slow process. On the average, 65% of an injected dose remains within the body after 7 days (40). The kidneys are the principal route of elimination during the first 24 hours. Following this phase, gallium is excreted primarily through the bowel, possibly as intestinal mucosal secretions (41-43).

Radioactivity in the intestine will interfere with the interpretation of abdominal gallium scans. For this reason, it is helpful to cleanse the bowel prior to imaging, which is initiated 48-72 hours after radiotracer injection. Laxatives or enemas may be utilized and usually are started on the day of gallium administration (44, 45). The following is an example of a bowel preparation regimen:

1. The patient is administered two bisacodyl tablets (5 mg) 48 hours before scanning.
2. On the day before imaging, the patient is given three bisacodyl tablets in the morning. At noon, a normal meal may be eaten. At 2 P.M., the patient will drink one bottle (12 oz) of magnesium citrate followed by 8 oz of water.
3. The patient is administered one bisacodyl suppository in the morning on the day of scanning.

More vigorous measures including enemas may be necessary if bowel radioactivity persists.

The efficacy of orally administered cathartics as a means of removing gut radioactivity has been questioned by some investigators (46, 47). The ineffectiveness noted by these authors may, in part, be due to patient noncompliance (48).

It has been suggested that confusion related to intestinal radiogallium may be minimized by imaging before the fecal elimination phase has

begun. Perkins (49), however, has shown that in addition to excessive background radioactivity due to incomplete blood clearance, some gallium is already present in the gastrointestinal tract at this time. Consequently, scan interpretation may be impeded when early imaging is attempted without bowel cleansing.

PANCREAS IMAGING ([⁷⁵Se]SELENOMETHIONINE)

The following is an example of the type of preparation which should be ingested by the patient prior to a pancreas scintigraphic imaging procedure:

Six egg whites
50 gm of Meritene
Artificial sweetener
100 ml whole milk

The preparation used should contain large quantities of fats and proteins. These substances, when in the duodenum, stimulate the release of cholecystokinin (CCK) into the circulation. Pancreatic production of digestive enzymes increases in response to elevated concentrations of CCK in the plasma (50). Therefore, it is believed that injected radioactive methionine, which will be utilized in digestive enzyme synthesis, is more readily transported into the pancreas when plasma CCK is high (51).

Other proposed methods of encouraging [⁷⁵Se]selenomethionine uptake include direct CCK administration or indirect stimulation by means of pharmacologically induced modifications of the parasympathetic or hypothalamic control over enzyme production (52-54). It has been suggested that pancreatic images may be further enhanced by inhibiting the accumulated radiotracer's discharge from the pancreas (55). All of these methods require further investigation.

THROMBUS LOCALIZATION ([¹²⁵I]-LABELED FIBRINOGEN)

As discussed previously, in order to prevent accumulation of ¹²⁵I by the thyroid gland, approximately 100 mg of potassium iodide should be administered to the patient 24 hours before

radioiodine injection. Potassium perchlorate may be used in patients who are sensitive to iodine. Thyroid blockage should be maintained for at least 20 days following ¹²⁵I-labeled fibrinogen administration (25, 56, 57).

With a waterproof marker, marks are made on the patient's legs over the greater saphenous veins. This is necessary in order to insure that probe positioning will be consistent from day to day during the course of the monitoring procedure. The marks must be close enough together so that the detector, when guided by these markings, will evaluate every segment of the veins. Generally, the markings are made at 2-inch intervals (58). Counts recorded over the patient's heart are used as a 100% reference to which the radioactivity assayed in the legs is compared (59, 60).

PARATHYROID IMAGING ([⁷⁵Se]SELENOMETHIONINE)

Under normal conditions, both the parathyroids and the thyroid gland concentrate appreciable amounts of selenomethionine (61). Therefore, parathyroid imaging should be preceded by thyroid blockade. The administration of thyroid hormone (e.g., Cytomel, 25 µg daily) will suppress thyroid function and thereby inhibit thyroidal uptake of radiomethionine. This permits better visualization of the parathyroid glands (62-64). Cytomel administration should begin 4 days before the study. A ^{99m}Tc-pertechnetate thyroid study, if indicated, should be performed prior to Cytomel suppression in order to achieve maximum pertechnetate uptake.

MECKEL'S DIVERTICULUM IMAGING ([^{99m}Tc]-PERTECHNETATE)

The identification of ectopic gastric mucosa by ^{99m}Tc-pertechnetate scintiscanning can be aided by pharmacologic intervention (see also Chapter 10). Several drugs have been shown to enhance the potential for lesion detection in these studies. Premedication of the patient with 300 mg of cimetidine will increase gastric mucosal retention of radiopertechnetate (65-66). It is theorized that cimetidine, a histamine H₂ re-

ceptor antagonist, inhibits parietal or superficial mucosal cell secretion of the radiotracer. Therefore, more radioactivity remains within the gastric mucosal tissue, and detection of these areas is enhanced (66).

Another pharmaceutical that shows promise in Meckel's diverticulum imaging studies is glucagon. This drug inhibits peristalsis, which thereby deters the transfer of pertechnetate through the stomach and small bowel (67). The radiotracer is, therefore, more likely to remain at the site of secretion, marking the lesion area.

The combination of glucagon with pentagastrin, a parietal cell agonist, appears to be even more effective than either glucagon or pentagastrin alone. Pentagastrin stimulates the uptake of pertechnetate by parietal cells. In a study by Khettery et al. (68), a 65% increase in murine gastric concentration of radiopertechnetate occurred following pentagastrin administration. When both glucagon and pentagastrin are administered prior to a Meckel's diverticulum imaging procedure, the visual quality of the resultant scan can be greatly improved (65).

Utilization of these or similar pharmaceuticals in Meckel's diverticulum scans has not gained widespread acceptance. There is evidence that pharmacologic intervention may not necessarily improve the procedure's potential for lesion detection (69) and that parietal cells may not be involved in gastric uptake and secretion of pertechnetate. In a study by Schweisinger et al. (69), the stomach concentration of radiotracer in patients receiving cimetidine or pentagastrin was not significantly different from that in control subjects. Further studies are indicated.

RENAL FUNCTION STUDIES ([¹²³I]IODOHIPPURATE OR [¹³¹I]IODOHIPPURATE)

Orally administered fluids can be used in [¹²³I]iodohippurate or [¹³¹I]iodohippurate renal function studies in order to assure adequate urine flow, if they are not contraindicated by the presence of edema or congestive heart failure. Approximately 10 ml of water or tea per kg body weight should be administered to the patient 1 hour prior to the procedure (70).

For a reliable study, it is recommended that the urine flow rate be at least 2 ml/min (71). Several investigators (72–75) have shown that in radioiodohippurate renograms, the time to peak and the slope of the descending curve are highly dependent on urine flow rate when urine excretion is slow. When the flow rate exceeds 2 ml/min, however, renal function curves in the normal patient remain fairly constant. Consequently, low urine flow rates can distort renogram curves, whereas more rapid urine outflow helps to assure that renograms will more consistently describe kidney function (71).

MYOCARDIAL PERFUSION STUDIES (²⁰¹Tl)THALLOUS CHLORIDE)

²⁰¹Tl-chloride nuclear medicine studies often include an evaluation of myocardial perfusion under physiologic stress (see also Chapter 10). In this procedure, the patient is exercised, usually on a treadmill, until at least 90% of predicted maximal heart rate is attained. An electrocardiogram is recorded throughout the study. The Bruce protocol (Table 26.1) is one example of a treadmill stress regimen that may be utilized in this procedure (76).

Table 26.1.
Bruce Multistage Exercise Protocol

Stage	Duration (Min)	Treadmill Speed (mph)	Treadmill Grade (%)
1	3	1.7	10
2	3	2.5	12
3	3	3.4	14
4	3	4.2	16
5	3	5.0	18
6	3	5.5	20
7	3	6.0	22

The patient should receive nothing by mouth (NPO) for approximately 4 hours prior to this or any similar rigorous exercise regimen. A ²⁰¹Tl-chloride dose is then administered quickly through a continuously running intravenous line (TKO) or other preestablished intravenous line, and exercise is continued for an additional 30–60 seconds. The imaging procedure should

commence within 3–10 minutes after exercise has been stopped (77, 78). Because of the possibility of arrhythmias or other cardiac complications, ²⁰¹Tl stress studies should be supervised by a cardiologist or other qualified physician. A defibrillator and all necessary medication should be available for immediate use.

Exercise-induced stress prior to imaging in ²⁰¹Tl studies serves two purposes. First, when the myocardial demand for oxygen is elevated by stress, perfusion of the cardiac tissue increases and myocardial uptake of the radiotracer will be more rapid and complete. In studies during exercise-induced stress, compared with those during rest, the concentration of thallium in the myocardium will be greater and there will be less activity in the liver, spleen, kidneys, and gastrointestinal tract (79–80). Second, areas of ischemic, yet not infarcted, myocardium which may not be detected in a thallium study during rest can often be demonstrated by a stress procedure. This is because stenotic myocardial blood vessels, which are capable of accommodating normal perfusion, are not able to dilate in response to more rapid blood flow during stress. Consequently, thallium distribution in the myocardium can be irregular (demonstrating ischemia) during exercise but appear uniform or normal during rest. Usually, both procedures are performed; i.e., a thallium scan during stress is followed approximately 4 hours later by a study during rest or redistribution (81–82).

An alternative to exercise in ²⁰¹Tl myocardial imaging is the induction of coronary vasodilation by pharmacologic agents such as dipyridamole (see also Chapter 10). In a study by Hamilton et al. (83), dipyridamole administration in dogs produced a 60% increase in the uptake of thallium by myocardial tissue. Several clinical investigators describe dipyridamole as being as effective as exercise in the production of non-uniform thallium distribution in the regionally ischemic myocardium (84–85). In redistribution studies, however, the results following exercise and dipyridamole may be dissimilar (86).

Dipyridamole can be administered by intravenous infusion (0.14 mg/kg/min for approximately 4 minutes) or orally. An oral dose of 200–300 mg has been used with satisfactory results (84).

HEPATOBIILIARY IMAGING (^{99m}Tc-IMINODIACETIC ACID (IDA) DERIVATIVES)

It may be helpful to have patients fast, when possible, for 2–6 hours prior to hepatobiliary scintigraphic procedures. In postprandial studies, visualization of the gallbladder is often appreciably delayed, a finding which may be erroneously interpreted as cystic duct obstruction or chronic cholecystitis (87–89). The radiotracer hepatocyte clearance and parenchymal transit time have also been shown to be affected by the ingestion of food prior to the study (87). In this case, there may be no interference with diagnosis. The ingestion of food can, however, interfere with the empirical determination of normal values for the involved cholescintigraphic parameters.

Theoretically, radiopharmaceutical passage into the gallbladder is inhibited in nonfasting patients by the outward flow of bile from the gallbladder toward the common bile duct. This movement of bile away from the gallbladder is established by gallbladder contraction and the relaxation of the sphincter of Oddi. These two actions are stimulated by CCK released into the bloodstream when food is present in the duodenum (90). It is believed that because CCK stimulation is not occurring in the fasting patient, the flow of bile will be toward the gallbladder, encouraging radionuclide movement in that direction (87).

Another technique for promoting gallbladder visualization is to administer CCK or sincalide (a synthetic CCK analog) before the scanning procedure (91, 92) (see also Chapter 10). This practice is effective as long as the radiopharmaceutical is administered after the acute contractile effects of CCK have dissipated.

The rationale for CCK premedication is as follows. If the cystic duct is patent, CCK-induced gallbladder contraction is believed to remove viscous bile from the gallbladder and cystic duct, which thereby minimizes resistance to subsequent radiotracer flow (91). If this is the case, the contraction obviously must be completed before the radiopharmaceutical has finished its transit through the hepatic parenchymal tissue and into the bile collecting system. Otherwise, outflowing bile would impede

the tracer's movement toward the gallbladder.

Freeman et al. (93) believe that premedication with CCK or sincalide may not be advantageous in cholescintigraphic studies, since sensitivity for the detection of chronic cholecystitis is markedly reduced. When gallbladder visualization is artificially stimulated, detection of chronic cholecystitis (usually associated with delayed gallbladder appearance) will not be possible. These investigators suggest that contraction should be induced only when the gallbladder has not been visualized after 2 hours of imaging. In this way, cystic duct patency can be evaluated without the ability to detect chronic disease being lost.

VARIOUS PROCEDURES (ORALLY ADMINISTERED RADIOPHARMACEUTICALS)

It is recommended that orally administered radioactive pharmaceuticals, like many other drugs, be taken on an empty stomach. The patient should not eat for several hours before radiotracer ingestion. The presence of food in the stomach may delay gastric emptying, which thereby decreases the rate of drug absorption from the duodenum (94–96). Furthermore, gastric contents can impede the drug's enteral disintegration and dissolution necessary for absorption into the bloodstream (97). Nuclear medicine procedures which involve the use of oral radioactive dosage forms include thyroid uptake and imaging studies, thyroid therapy, Schilling tests, and other gastrointestinal absorption evaluations.

CONCLUSION

In this chapter are described methods of patient preparation that can favorably affect the outcome of nuclear medicine studies in specific situations. Some of these practices may be considered essential to the success of the nuclear medicine procedure, whereas others may be thought of simply as a means of obtaining more valid or reliable information. Regardless of relative importance, each of the preparatory methods discussed can contribute to the quality of the respective study and can serve as a means of maximizing the value of nuclear medicine procedures.

The specific patient preparation techniques discussed in this chapter may not be readily applicable to every practice setting or situation. These or similar procedures can be used or modified as necessary. It is important, however, that when new protocols are developed, the rationale and theoretical basis of each technique be considered.

REFERENCES

- Hladik WB, Nigg KK, Rhodes BA: Drug-induced changes in the biologic distribution of radiopharmaceuticals. *Semin Nucl Med* 12:184-218, 1982.
- Lentle BC, Schmidt R, Noujaim AA: Iatrogenic alterations in the biodistribution of radiotracers. *J Nucl Med* 19:743, 1978.
- Hodges RL: Drug interactions and incompatibilities with Tc-99m radiopharmaceuticals. *J Nucl Med* 19:743, 1978.
- Lentle BC, Scott JR, Noujaim AA, et al: Iatrogenic alterations in radionuclide biodistributions. *Semin Nucl Med* 9:131-143, 1979.
- Gates GF: Pediatric nuclear medicine. In Greenfield LD, Uszler JM (eds): *Nuclear Medicine in Clinical Practice*. Deerfield Beach, FL, Velag Chemie International, 1982, pp 289-305.
- Ulysses R, Alncedia F, Meguerian BA: Pediatric considerations. In Rocha AFG, Harbert JC (eds): *Textbook of Nuclear Medicine*. Philadelphia, Lea & Febiger, 1979, pp 456-461.
- Conway JJ: Considerations for the performance of radionuclide procedures in children. *Semin Nucl Med* 2:305-318, 1972.
- Mealey J: Brain scanning in childhood. *J Pediatr* 69:399, 1966.
- Harvey SC: Hypnotics and sedatives. In Gilman AG, Goodman LS, Gilman A (eds): *Pharmacological Basis of Therapeutics*. New York, Macmillan, 1980, pp 339-375.
- Grayson RR: Factors which influence the radioactive iodine thyroidal uptake test. *Am J Med* 28:397-415, 1960.
- Reynolds R, Kotchen TA: Antithyroid drugs and radioactive iodine, fifteen year's experience with Graves' disease. *Arch Intern Med* 139:651-653, 1979.
- Levy RP, Marshall JS: Short-term drug effects on thyroid function tests. *Arch Intern Med* 114:413-416, 1964.
- Austen FK, Rubini ME, Meroney WH, et al: Salicylates and thyroid function, I. Depression of the thyroid function. *J Clin Invest* 37:1131-1143, 1958.
- Magalotti MF, Hummon IF, Hierschbiel E, et al: Effect of disease and drugs on twenty-four hour I-131 thyroid uptake. *Am J Roentgenol* 81:47, 1959.
- Clark RE, Shipley RA: Thyroidal uptake of I-131 after iopanoic acid (Telepaque) in 74 subjects. *J Clin Endocrinol* 17:1008, 1957.
- Kohn LA, Nichols EB: Interference with uptake of radioiodine tracer during administration of vitamin-mineral mixtures. *N Engl J Med* 253:286-287, 1955.
- Linsk J, Paton B, Persky M, et al: The effect of phenylbutazone and a related analogue (G25671) upon thyroid function. *J Clin Endocrinol* 17:416-423, 1957.
- Novrok DS, Glascock RJ, Solomon DH, et al: Hypothyroidism following prolonged sodium nitroprusside therapy. *Am J Med Sci* 248:129-135, 1964.
- Beasley TM, Palmer HE, Nelp WB: Distribution and excretion of technetium in humans. *Health Phys* 12:1425-1435, 1966.
- Lathrop KA, Harper PV: Biologic behavior of ^{99m}Tc from ^{99m}Tc-pertechnetate ion. *Prog Nucl Med* 1:145-162, 1972.
- Haden HT: Thyroid function tests; physiologic basis and clinical interpretation. *Postgrad Med* 40:129-137, 1966.
- Wood DE, Gilday DL, Eng B, et al: Stable iodine requirements for thyroid gland blockage of iodinated radiopharmaceuticals. *J Can Assoc Radiol* 25:295-296, 1974.
- Sternthal E, Lipworth L, Stanley B, et al: Suppression of thyroid radioiodine uptake by various doses of stable iodide. *N Engl J Med* 303:1083-1088, 1980.
- Rhodes BA, Croft BY: *Basics of Radiopharmacy*. St Louis, CV Mosby, 1978, pp 54-60.
- Conn JW, Cohen EL, Herwig KR: The dexamethasone-modified adrenal scintiscan in hyporeninemic aldosteronism (tumor versus hyperplasia). A comparison with adrenal venography and adrenal venous aldosterone. *J Lab Clin Med* 88:841-856, 1976.
- Kakkar VV: Fibrinogen uptake test for the detection of deep vein thrombosis—a review of current practice. *Semin Nucl Med* 7:229-244, 1977.
- Wynngaarden JB, Wright BM, Ways R: The effect of certain anions upon the accumulation and retention of iodide by the thyroid gland. *Endocrinology* 50:537-539, 1952.
- Godley AF, Stanbury JB: Preliminary experience in the treatment of hyperthyroidism with potassium perchlorate. *J Clin Endocrinol* 14:70, 1954.
- Castronovo FP, Guiberteau MJ, Berg G, et al: Pharmacokinetics of technetium-99m diphosphonate. *J Nucl Med* 18:809-814, 1977.
- Makler PT, Charkes ND: Studies of skeletal tracer kinetics IV. Optimum time delay for Tc-99m (Sn) methylene diphosphonate bone imaging. *J Nucl Med* 21:641-645, 1980.
- Subramanian G, McAfee JG, Blair RJ, et al: An evaluation of ^{99m}Tc-labeled phosphate compounds as bone imaging agents. In Subramanian G, Rhodes B, Cooper JF, et al (eds): *Radiopharmaceuticals*. New York, Society of Nuclear Medicine, 1975, pp 319-328.
- Krishnamurthy GT, Huebner RJ, Tubis M, et al: Pharmacokinetics of current skeletal seeking radiopharmaceuticals. *Am J Roentgenol* 126:293-301, 1976.
- Pendergrass HP, Potsaid MS, Castronovo IP: The clinical use of ^{99m}Tc-diphosphonate. *Radiology* 107:557-1973.
- Sodee D, Early P: *Technology and Interpretation of Nuclear Medicine Procedures*. St Louis, CV Mosby, 1975, p 314.
- Weber DA, Keyes JW, Wilson GA, et al: Kinetics and imaging characteristics of ^{99m}Tc-labeled complexes used for bone imaging. *Radiology* 120:615-621, 1975.
- Bardfield PA, Holmes RA: Pertechnetate accumulation in the choroid plexus. *Am J Med Sci* 254:542-548, 1967.
- Witcfski EL, Janeway R, Maynard D, et al: Visualization of the choroid plexus on the technetium 99m brain scan. *Arch Neurol* 16:286-289, 1967.
- Maxwell ME, Baggstoss BJ: Efficacy of administering simultaneous oral perchlorate and intravenous ^{99m}TcO₄⁻ for brain scanning. *J Nucl Med Technol* 3:138-140, 1975.
- Hays MT, Berman M: Pertechnetate distribution in man after intravenous infusion in a compartmental model. *J Nucl Med* 18:898-904, 1977.
- Clausen J, Edeby CJ, Fogh J: ⁶⁷Ga binding to human serum proteins and tumor components. *Cancer Res* 34:1931-1937, 1974.
- Andrews GA, Edwards CL: Tumor scanning with gallium 67. *JAMA* 233:1100-1103, 1975.
- Taylor A, Chafetz N, Hollerbeck J, et al: The source of fecal gallium—clinical implications: concise communication. *J Nucl Med* 19:1214-1216, 1978.
- Hayes RI: The tissue distribution of gallium radionuclides. *J Nucl Med* 18:740, 1977.
- Moynuddin M, Rockett JF: Gallium imaging in inflammatory diseases. *Clin Nucl Med* 1:217-278, 1976.
- Hoffer PB: Imaging technique. In Hoffer PB, Beckerman C, Henkin RE (eds): *Gallium 67 Imaging*. New York, John Wiley & Sons, 1978, pp 15-17.
- Silberstein EF, Fernandez-Volle M, Hall J: Are oral cathartics of value in optimizing the gallium scan? Concise communication. *J Nucl Med* 22:424-427, 1981.
- Zeman RK, Ryerson TW: The value of bowel preparation in Ga-67 citrate scanning. Concise communication. *J Nucl Med* 18:886-889, 1977.
- Novetsky GJ, Turner DA, Ali A, et al: Cleansing the colon in gallium-67 scintigraphy. A prospective comparison of regimens. *AJR* 137:979-981, 1981.
- Perkins PJ: Early Gallium-67 abdominal imaging: pitfalls due to bowel activity. *AJR* 136:1016-1017, 1981.
- Price SA, McCarty Wilson L: *Patho-physiology: Clinical Concepts of Disease Processes*. New York, McGraw-Hill, 1978, pp 206-210.
- Rodriguez-Antonez A, Ahidi R, Gill M: Pancreas scanning. Critical reviews in the radiological sciences. *Radiol Sci* 1:25-46, 1970.
- Melmed RN, Agnew JE, Bouchier IDA, et al: The normal and abnormal pancreatic scan. *Q J Med* 37:607-624, 1968.
- Cottrill MF, Taylor DM: (⁷⁵Se)Selenomethionine uptake by the pancreas. *J Nucl Med* 21:191-192, 1980.
- Atkins HL, Som P: Growth-hormone and somatostatin effects on (⁷⁵Se)selenomethionine uptake by the pancreas. *J Nucl Med* 20:543-546, 1979.
- Winston MA, Guth P, Endow JS, et al: Enhancement of pancreatic concentration of ⁷⁵Se-selenomethionine. *J Nucl Med* 15:662-666, 1974.
- Negus D, Pinto DL, Lequesne LP, et al: ¹²⁵I-labelled fibrinogen in the diagnosis of deep vein thrombosis and its correlation with phlebography. *Br J Surg* 55:835-842, 1968.
- Becker J: The diagnosis of venous thrombosis in the legs using I-labelled fibrinogen. *Acta Chir Scand* 138:667-680, 1972.
- Hume M, Gurrewich V: Peripheral venous scanning with ¹²⁵I-tagged fibrinogen. *Lancet* 1:845-849, 1972.
- Mavor GE, Mahaffy RG, Walker MG, et al: Peripheral venous scanning with ¹²⁵I-tagged fibrinogen. *Lancet* 1:661, 1972.
- Kakkar VV: Peripheral venous scanning with ¹²⁵I-tagged fibrinogen. *Lancet* 1:910, 1972.
- Potchen EJ, Wats GH, Awwad HK: Parathyroid scintiscanning. *Radiol Clin North Am* 5:267-275, 1967.
- Colella AC, Pignorini F: Experience with parathyroid scintigraphy. *Am J Roentgenol* 109:714-723, 1970.
- Potcher EJ, Awwad HK, Adelstein SJ, et al: The thyroid uptake of selenium-75-selenomethionine: effect of L-thyroxine and thyroid stimulating hormone. *J Nucl Med* 7:433-441, 1966.
- Crocker EF, Jellins J, Freund J: Parathyroid lesions localized by radionuclide subtraction and ultrasound. *Radiology* 130:215-217, 1979.
- Petrokubi RJ, Baum S, Rohner GV: Cimetidine administration resulting in improved pertechnetate imaging of Meckel's diverticulum. *Clin Nucl Med* 3:385-388, 1978.
- Sagar VV, Piccone JM: The gastric uptake and secretion of Tc-99m pertechnetate after H₂ receptor blockage in dogs. *J Nucl Med* 21:67, 1980.
- Sfakianakis GN, Anderson GF, King DR, et al: The effect of gastrointestinal hormones on the pertechnetate imaging of gastric mucosa in experimental Meckel's diverticulum. *J Nucl Med* 22:678-683, 1981.
- Khettery J, Eftmann E, Grand RJ, et al: Effect of pentagastrin, histalog, glucagon, secretin and perchlorate on the gastric handling of ^{99m}Tc-pertechnetate in mice. *Radiology* 120:629-631, 1976.
- Schweisinger WH, Straw JD, Chaudhuri TK: Effect of cimetidine and pentagastrin on scintigraphic studies of stomach with Tc-99m-pertechnetate. *J Nucl Med* 22:87, 1981.
- Sodee D, Early P: *Technology and Interpretation of Nuclear Medicine Procedures*. St Louis, CV Mosby, 1975, pp 321-326.
- Farnclant MH, Dukstrin W, Burrows BA: Influence of water and mannitol loads on radio-hippuran renal function curves. *J Nucl Med* 11:186-189, 1970.
- Wax SH, McDonald DF: Analysis of the I-131 sodium-o-iodohippurate renogram. *J Am Med Assoc* 213:140, 1962.
- Meade RC, Shy CM: The evaluation of individual kidney function using radiohippurate sodium. *J Urol* 66:163-170, 1961.
- Wedden RP, Goldstein MH, Levitt MF: The radioiso-

- tope renogram in normal subjects. *Am J Med* 34:765-768, 1963.
75. O'Connor VI, Libretti JV, Grayback JT: The early differential diagnosis of post-operative anuria using the radioactive renogram: an experimental study. *J Urol* 86:276-282, 1961.
76. Bruce RA: Exercise testing of patients with coronary heart disease: principles and normal standards for evaluation. *Ann Clin Res* 3:323-340, 1971.
77. Hamilton GW, Trobaugh GB, Ritchie JL, et al: Myocardial imaging with intravenously injected thallium-201 in patients with suspected coronary artery disease. analysis of technique and correlation with electrocardiographic, coronary anatomic and ventriculographic findings. *Am J Cardiol* 39:347-352, 1977.
78. Bailey LK, Griffith LSC, Strauss HW, et al: Detection of coronary artery disease and myocardial ischemia by electrocardiography and myocardial perfusion scanning with thallium-201. *Am J Cardiol* 37:118-126, 1976.
79. Atkins HL, Budinger TF, Lebowitz E, et al: Thallium-201 for medical use III. Human distribution and physical imaging properties. *J Nucl Med* 18:133-138, 1977.
80. Strauss HW, Hamisonk, Langan JK, et al: Thallium-201 for myocardial imaging. Relation of thallium-201 to regional myocardial perfusion. *Circulation* 51:641-660, 1975.
81. Pohost GM, Zin LM, McKussick KA, et al: Differentiation of transiently ischemic from infarcted myocardium by serial imaging after a single dose of thallium-201. *Circulation* 55:294-299, 1977.
82. Ritchie JL, Trobaugh GB, Hamilton GW, et al: Myocardial imaging with thallium-201 at rest and during exercise: comparison with coronary arteriography and resting and stress electrocardiography. *Circulation* 56:66-81, 1977.
83. Hamilton GW, Narahara KA, Yee H, et al: Myocardial imaging with thallium-201: effect of cardiac drugs on myocardial images and absolute tissue distribution. *J Nucl Med* 19:10-16, 1978.
84. Albro PC, Gould KL, Westcott RJ, et al: Noninvasive assessment of coronary stenoses by myocardial imaging during pharmacologic coronary vasodilation III. Clinical trial. *Am J Cardiol* 42:751-760, 1978.
85. Albro PC, Gould KL, Westcott RJ, et al: Noninvasive assessment of coronary disease in man by myocardial imaging during pharmacologic vasodilation. *J Nucl Med* 19:743, 1978.
86. Sklar J, Kirch D, Eouth J, et al: Differences in thallium redistribution after exercise and dipyridamole infusion. *J Nucl Med* 22:41, 1981.
87. Klingensmith WC, Spitzer VN, Fritzberg AR, et al: The normal fasting and post-prandial diisopropyl IDA Tc-99m hepatobiliary study. *Radiology* 141:771-776, 1981.
88. Weissmann HS, Frank MS, Bernstein LH, et al: Rapid and accurate diagnosis of acute cholecystitis with 99mTc-HIDA cholescintigraphy. *AJR* 132:523-528, 1979.
89. Baker RJ, Marion MA: Biliary scanning with Tc-99m pyridoxylidenglutamate: the effects of food in normal subjects. *J Nucl Med* 18:793-795, 1977.
90. Hendryx TR: The absorptive function of the alimentary canal. In Mountcastle VB (ed): *Medical Physiology*. St Louis, CV Mosby, 1980, vol 2, pp 1305-1307.
91. Eikman EA, Cameron JL, Colman M, et al: Radioactive tracer techniques in the diagnosis of acute cholecystitis. *J Nucl Med* 14:392, 1973.
92. Eikman EA, Cameron JL, Colman M, et al. Test for patency of the cystic duct in acute cholecystitis. *Ann Intern Med* 82:318-322, 1975.
93. Freeman LM, Sugarman LA, Weissman HS: Role of cholecystokinetic agents in 99mTc-IDA cholescintigraphy. *Semin Nucl Med* 11:186-193, 1981.
94. Toothaker RD, Welling PG: The effect of food on drug bioavailability. *Ann Rev Pharmacol Toxicol* 20:173-199, 1980.
95. Levine RR: Factors affecting gastrointestinal absorption of drugs. *Am J Dig Dis* 15:171-188, 1970.
96. Nimmo WS. Drugs, diseases and altered gastric emptying. *Clin Pharmacokinetics* 1:189-203, 1976.
97. Mayer SE, Melmon KL, Gilman AG: Introduction: the dynamics of drug absorption, distribution and eliminations. In Gilman AG, Goodman LS, Gilman A (eds): *The Pharmacological Basis of Therapeutics*. New York, Macmillan, 1980, pp 5-6.

Index

Page numbers in *italics* indicate illustrations; *t* following a page number indicates tabular material.

- Abdomen, clinical variations in, radiopharmaceutical bio-distribution and, 244, 245
- Abdominal imaging, gastrointestinal bleeding and, 123-124
- Abscess localization
drug-radiopharmaceutical interactions affecting
[⁶⁷Ga]gallium citrate in, 211-215
¹¹¹In-labeled leukocytes in, 203
[⁶⁷Ga]gallium citrate for, 14-15
¹¹¹In-labeled leukocytes for, 15, 94-95
[⁶⁷Ga]gallium citrate versus, 79
patient preparation for, 414
- Absorbed dose (*see also* Dose)
altered biodistribution and, 69-71
general principles of, 51-53
investigational new drugs, 53-55, 363
lactation and, 59-64
pediatric (*see* Pediatric patient)
pregnancy and, 64-69
radionuclidic impurities and, 283
regulatory agencies and, 53-56
- Acalculous cholecystitis, 127
- Accuracy, test, 135, 135, 137*t*
- ACD (*see* Acid-citrate-dextrose)
- Acetaminophen, 99mTc-glucelate interaction with, 197
- Acetazolamide, ¹¹¹In-DTPA and ¹⁶⁹Yb-DTPA interactions with, 202
- Acid-citrate-dextrose (ACD), 281-282
- Acidosis, [⁶⁷Ga]gallium citrate and, 179
- Acquisition, mode of, 146, 148
- Actinomycin D (*see* Dactinomycin)
- Addictive drugs of abuse, [⁶⁷Ga]gallium citrate interaction with, 212
- Adenocarcinoma, animal model of, 346*t*
- Adenoma, adrenal, 116-117
- Administration
errors in, absorbed dose and, 70-71
route of
inadvertently altered, 230
selection of radiopharmaceutical and, 79
- Adrenal cortex imaging, drug-radiopharmaceutical interactions affecting, [¹³¹I]iodomethylnorcholesterol in, 205-206
- Adrenal gland
clinical variations in, radiopharmaceutical biodistribution and, 243
- hyperplasia of, versus adenoma, 116-117
imaging of
NP-59, 12
pathologic mechanisms altering, 260
interventional studies, of, 116-117, 117
- Adrenal medulla imaging, drug-radiopharmaceutical interactions affecting, mIBG in, 206-207
- β-Adrenergic blockers
99mTc-labeled red blood cell interactions with, 199-201
[²⁰¹Tl]thallous chloride interactions with, 207-208, 209
- Adverse reactions, 303-319
characteristics of, 313-317, 314*t*-315*t*
definition of, 303-304
incidence of, 317-318
reporting system for, 304-310, 305-309
statistics on, 310-313, 311*t*-313*t*
type A versus type B, 304
type B, validation of, 319
validation of, 318-319
- Aerosol (*see* Radioaerosols)
- Age (*see also* Pediatric patient)
biokinetics and, 57, 58, 58*t*
bone scan and, 237, 237*t*
radiation risks and, 58-59
therapeutic effect and, 112-113, 112*t*, 113
- Agreement states, 53, 322*t*-323*t*
- ALARA, 329
- Albumin
iodinated serum, fetal dose of, 66
macroaggregated (*see* 99mTc-labeled albumin, macroaggregated)
99mTc-labeled (*see* 99mTc-labeled albumin)
- Albumin microspheres (*see also* 99mTc-labeled albumin), 5
- Albuterol, gastric emptying radiopharmaceutical interactions with, 216
- Alcohol (*see* Benzyl alcohol; Ethanol)
- Aldosteronoma, 117
- Alkylating agents, side effects of, 85
- Allergic reactions, 313
albumin particulates and, 316
colloids and, 316
- Allograft rejection, 258-260
- Allopurinol, [⁶⁷Ga]gallium citrate interactions with, 214-215
- Aluminum (*see also* Hyperalbuminemia), liver uptake of radiotracers and, 177

- Aluminum ion, formulation problems caused by, 270, 274
 Aluminum-containing antacids
^{99m}Tc-labeled phosphate and phosphonate interactions with, 194-195
^{99m}Tc-pertechnetate interactions with, 199
 American Hospital Association, "Patient's Bill of Rights" and, 404-405
 ε-Amino caproic acid, ^{99m}Tc-labeled phosphate and phosphonate interactions with, 196
 Aminoglycosides, renal function radiopharmaceutical interactions with, 218
 p-Aminosalicylic acid, radiocyanocobalamin interactions with, 209-210
 Amiodarone, [⁶⁷Ga]gallium citrate interactions with, 212
 Ammonium chloride, ^{99m}Tc-DMSA interactions with, 197-198
 Amphotericin B, ^{99m}Tc-labeled phosphate and phosphonate interactions with, 194
 Ampicillin, [⁶⁷Ga]gallium citrate interactions with, 214-215
 Amyloidosis, animal models of, 343-345, 345r
 Analog-to-digital converters, 146, 147, 147r
 Anatomic structure, normal variations in, radiopharmaceutical biodistribution and, 234-245
 Androgens, ^{99m}Tc-labeled colloid interactions with, 190-191
 Anemia, hemolytic, animal model of, 345, 345r
 Anesthetics
 cell membrane effects of, 167, 168, 178
 radioxenon interactions with, 211
 reticuloendothelial system affected by, 174
^{99m}Tc-labeled colloid interactions with, 191
 Angiocardigraphy, 119
 Angiography, cerebral, psychotropic drug effects on, 217
 Animal models, 333-347
 amyloidosis, 343-345, 345r
 cardiovascular systems, 334-336, 337r
 central nervous system, 336, 338r
 clinical testing preceded by, 362
 defined, 333-334
 diabetes, 343, 344r
 digestive system, 338-339, 340r
 genitourinary system, 341-342, 342r
 hematologic disorders, 345, 345r
 hepatobiliary system, 339-341, 341r
 investigational drug, 34-35, 362
 metabolic disorders, 345
 oncologic, 346-347, 346r
 respiratory system, 336-338, 339r
 skeletal system, 334, 335r
 Anions, radiopharmaceutical, metabolism of, 45-46
 Annihilation, radiation, tomography and, 160
 Antacids
 aluminum-containing
^{99m}Tc-labeled phosphate and phosphonate interactions with, 194-195
^{99m}Tc-pertechnetate interactions with, 199
 gastroesophageal reflux and, 122
^{99m}Tc-labeled colloid interactions with, 190-191
 Anthracyclines, cardiotoxic effects of, 181-182
 Antibiotics (see also specific agent; specific class of antibiotics)
 cell membrane effects of, 167
 [⁶⁷Ga]gallium citrate interactions with, 214-215
 [¹¹¹In]-labeled leukocyte interactions with, 203
 thyroid-scanning effects of, 184
 Antibodies, labeled, radiodiagnostics based on, 36
 Anticoagulants, formulation problems related to, 281-282
 Anticonvulsants, radiocyanocobalamin interactions with, 209-210
 Antidepressants, tricyclic, MIBG interactions with, 206-207
 Antihistamines, thyroid-scanning effects of, 183
 Antimony sulfide colloid, ^{99m}Tc-labeled, normal biodistribution of, 6-7
 Antioxidants, ^{99m}Tc-labeled radiopharmaceuticals and, 81, 81r, 280
 Antithyroid agents
 effects on thyroid-scanning agents, 183
 iodide interactions with, 204, 204r
 Arteriovenous shunt, 252, 252r
 Arteritis, animal models of, 337r
 Arthritis, animal models of, 335r
 Artifact manual, 290
 Artifacts, 290
 collimator selection and, 294
 frequent causes of, 391r
 quality control procedures and, 291
 renal imaging, 296
 single photon emission computed tomography, 300
 Aseptic meningitis, animal models of, 336, 338r
 Asialoproteins, 166
 Asplenia, 226
 Asthma, animal models of, 338, 339r
 Atherosclerosis
 animal models of, 335, 337r
 carotid artery, [¹¹¹In]-labeled platelets in diagnosis of, 96
 Atresia, biliary, neonatal hepatitis versus, 126
 Atropine
 brain imaging preceded by, 413
 gastric emptying radiopharmaceutical interactions with, 216
 Attenuation correction, 159
¹⁹⁸Au colloid, 86, 316
 Azygos fissure, 244
 Azygos lobe, 244
Bacillus Calmette-Guérin, [⁶⁷Ga]gallium citrate interactions with, 212
 Bacteriostatic saline, ^{99m}Tc-labeled radiopharmaceuticals and, 281
 Bar phantoms, problems with use of, 291, 292, 294
 Bayes' theorem, 105, 137-139, 138
 Benzodiazepines, iodide interactions with, 204, 204r
 Benzyl alcohol
 [⁶⁷Ga]gallium citrate and, 180
 limited preservative applications of, 281
 Bethanechol
 contraindications to, 122
 gastroesophageal reflux and, 120, 122
 BIDA (see Butyl iminodiacetic acid)
 Biguanides, radiocyanocobalamin interactions with, 209-210
 Biliary atresia, neonatal hepatitis versus, 126
 Biliary obstruction
 animal models of, 341r
 diagnosis of, with iminodiacetic acid compounds, 26
 extrahepatic, 126
 Biodistribution
 altered
 absorbed dose and, 69-71
 drug-induced
 reported instances of, 189-219
 theoretical considerations, 165-184
 frequent causes of, 391r
 invasive therapy causing, 220-230
 pathologic mechanisms causing, 248-263
 drug effects on
 blood components and, 169
 cell membrane and, 166-169
 enzymes and, 169
 factors determining, 166
 formulation problems and, 268-284
 normal, 3-16
 clinical variations of, 69, 234-245
 structure and, 33-42
 Biokinetics, age and, 57
 Biopsy, radiotracer distribution affected by, 226, 227
 Bleeding, gastrointestinal (see Gastrointestinal bleeding)
 Bleomycin
 [⁶⁷Ga]gallium citrate interactions with, 212
 toxicity, 263
 Blood-brain barrier, pertechnetate uptake and, 4, 169, 170, 171
 Blood components
 drug effects on, radiotracer distribution and, 169
 radiolabeled, preparation and clinical utility of, 90-96
 Blood flow
 bone, animal models of measurement of, 334, 335r
 cerebral, scintigraphic computer analysis of, 157
 intestinal, animal models of, 340r
 Blood pool imaging, 119, 151-154, 151r-152, 155
 animal models of, 345, 345r
^{99m}Tc-labeled red blood cells in, 11
^{99m}Tc-pertechnetate in, 4
 Blood transfusion, radiotracer biodistribution and, 229
 Bone (see also entries beginning with Skeletal)
 animal models of disease in, 334, 335r
 clinical variations in, radiopharmaceutical biodistribution and, 237, 237r, 238
 cold lesions of, 260
 therapeutic irradiation of, radiotracer distribution affected by, 221, 223, 224
 Bone imaging
 colloidal impurities in, 268, 269
 drug effects on agents for, 175-178
 evaluation of therapy with, 102
 free pertechnetate in, 268, 269
 liver uptake in agents for, factors associated with, 393r
 pathologic mechanisms altering, 257-262, 260-262
 patient preparation for, 413
 selection of radiopharmaceutical for, 80, 81r
 structure-distribution relationships of ^{99m}Tc-labeled agents for, 41, 41r
^{99m}Tc-phosphonate compounds in, 7-8
 Bone infarct, [¹¹¹In]-labeled leukocytes for diagnosis of, 95
 Bone marrow, therapeutic irradiation of, radiotracer distribution affected by, 223-225, 225
 Bone marrow imaging
 drug-radiopharmaceutical interactions affecting, ^{99m}Tc-labeled colloids in, 190-191
 pathologic mechanisms altering, 262
 Bone pain, sodium [³²P]phosphate for, 85, 86
 Bowel preparation regimen, abdominal imaging preceded by, 414
 Brain imaging
 drug-radiopharmaceutical interactions affecting, 216-217
^{99m}Tc-pertechnetate in, 169-171, 199
 normal clinical variations affecting, 236, 237r
 pathologic mechanisms altering, 248, 249
 patient preparation for, 413-414
^{99m}Tc-DTPA, 4-5
^{99m}Tc-glucaptate, 5
^{99m}Tc-pertechnetate, 4
 Brain tumor (see also Central nervous system, diseases of)
 animal models of, 336, 338r
 Breast
 cancer of, animal models of, 346-347
 clinical variations in, radiopharmaceutical biodistribution and, 239
 Breast milk (see also Lactation), 59
 radioactivity in, 59-61, 60r, 239
^{99m}Tc ingested in, 62-63, 62r-63r
 Bromosulfophthalein (BSP), hepatobiliary animal models and, 339-340
 3-Bromo-2,4,6-trimethylphenylcarbamoylmethyliminodiacetic acid (mebrofenin), structure of, 38, 39
 Bronchitis, chronic, animal models of, 338, 339r
 Bruce multistage exercise protocol, 416r
 BSP (see Bromosulfophthalein)
 Busulfan, [⁶⁷Ga]gallium citrate interactions with, 212
 Butyl iminodiacetic acid (BIDA), ^{99m}Tc-labeled, normal biodistribution of, 9
 By-products, 53
¹⁴C-DTPA, metabolism of, 48
 [¹⁴C]glucose, sperm metabolism assessed by, 102-103, 103r
 Caffeine, effects on sperm, 102-103, 103r
 Calcitonin, effects on radiopharmaceuticals, 176
 Calcium channel blockers
 cell membrane effects of, 168
^{99m}Tc-labeled red blood cell interactions with, 199-200
 Calcium chelating agents, radiocyanocobalamin interactions with, 209-210
 Calcium gluconate
 [⁶⁷Ga]gallium citrate interactions with, 214
^{99m}Tc-labeled phosphate and phosphonate interactions with, 195

- Calcium ion
cell membrane effects of, 168
digitalis and, 181
effects on radiotracer distribution, 176, 177
- Camera
gamma (see Gamma camera)
single photon emission computed tomography, 298, 298
calibration problems with, 299, 299
relation to patient, 299-300
- cAMP (see Cyclic adenosine monophosphate)
- Cancer (see also Carcinoma; specific site)
animal models of, 346-347, 346t
chemotherapeutic agents for (see Chemotherapeutic agents)
radiation-induced, age and, 58-59
- Captopril, ^{99m}Tc-DMSA interactions with, 198
- Carcinoma (see also Cancer)
lung, animal models of, 338, 339t
sodium [¹³¹I]iodide for, 88
thyroid, 251
- Cardiac function, multiple-gated imaging of, 153-154, 153t
- Cardiac glycosides, [²⁰¹Tl]thallous chloride interactions with, 209
- Cardiac imaging
monitoring with, 102
pathologic mechanisms altering, 251-252
physiologic intervention in, 119
^{99m}Tc-labeled albumin, 11
^{99m}Tc-labeled phosphate, 8
^{99m}Tc-labeled red blood cell, 11, 91
[²⁰¹Tl]thallous chloride, 13
- Cardiac massage, external, radiopharmaceutical bio-distribution and, 228-229, 229
- Cardiac perfusion abnormalities (see also Myocardial perfusion imaging), 118, 118t
- Cardiac radiotracers, drug effects on, 180-183
- Cardioactive drugs, cyclic adenosine monophosphate and, 181
- Cardiology, 180-183
scintigraphic computer in, 150-157
- Cardiotoxicity, anthracycline, 181-182
- Cardiovascular system
diseases of, animal models of, 334-336, 337t
imaging of, pathologic mechanisms affecting, 251-252
interventional studies of, 117-119
^{99m}Tc-labeled red blood cell, 91
- Cardioversion, 262
radiotracer biodistribution and, 228, 228
- Carotid artery, radiolabeled platelet examination of, 96
- Carrier ^{99m}Tc, formulation problems with, 268, 270
- Cation permeability of membranes, immunologic reactions and, 167
- Cations, radiopharmaceutical, metabolism of, 45
- CCK (see Cholecystokinin)
- Cell membrane
drug effects on, radiotracer distribution and, 166-169
permeability, 166-167
- Cellophane, dialyzer, complement activation and, 173
- Cellular effects of radiation, 110-111
- Central nervous system (see also Brain imaging)
clinical variations in, radiopharmaceutical biodistribution and, 236, 237t
diseases of, animal models of, 336, 338t
radiopharmaceuticals for, pathologic alteration in bio-distribution of, 248-249, 249-250
- Central processing unit (CPU), 149-150
- Cephalexin, [⁶⁷Ga]gallium citrate interactions with, 214-215
- Cephalosporins, [⁶⁷Ga]gallium citrate interactions with, 214-215
- Cerebral blood flow analysis, scintigraphic computer in, 157
- Cerebral infarction, animal models of, 336
- Cerebral microembolism, animal models of, 336, 338t
- Cerebral perfusion studies, patient positioning for, 413-414
- Cerebral spinal fluid clearance, rate of, 248-249
- Ceruletide, 126, 128
- Chemoperfusion
radiotracer biodistribution and, 229
regional, ^{99m}Tc-labeled phosphate and phosphonate interactions with, 195
- Chemotherapeutic agents
brain-imaging radiotracer interactions with, 216-217
combination, [⁶⁷Ga]gallium citrate interactions with, 212
"cytotoxic," ^{99m}Tc-labeled phosphate and phosphonate interactions with, 194
[⁶⁷Ga]gallium citrate interactions with, 213, 215
^{99m}Tc-labeled colloid interactions with, 190
- Children (see Pediatric patient)
- Chloral hydrate, pediatric patient sedation with, 412
- Chloroquine, [⁶⁷Ga]gallium citrate affected by, 179
- Chlorpromazine (CPZ), ³²P and, 168
- Cholecystitis, 126, 127, 255
- Cholecystographic agents, iodide interactions with, 204t
- Cholecystokinetic agents, 126-127, 128
- Cholecystokinin (CCK), 126
hepatobiliary imaging and, 417
stimulation of, pancreas imaging preceded by, 414
- Cholescintigraphy
drug-radiopharmaceutical interactions affecting, ^{99m}Tc-
iminodiacetic acid derivatives in, 191-182
sincalide with, 126-127
- Cholestyramine, radiocyanocobalamin interactions with, 209-210
- Chromatography, high-performance liquid (HPLC),
^{99m}Tc-N,N'-bis(mercaptoacetyl)-2,3-diaminopro-
panoate, 37
- Chromic [³²P]phosphate
description of, 86
dose of, 86-87
indications for, 86
mechanisms of action of, 86
metabolism of, 46
monitoring parameters for, 87
pharmacodynamics of, 87
toxicity of, 87
- Cimetidine, Meckel's diverticulum detection and, 125, 415
- Cisplatin
[⁶⁷Ga]gallium chloride interactions with, 213
renal function radiotracer interactions with, 218
- Cisternography
agents for, adverse reactions to, 317
drug-radiopharmaceutical interactions affecting, [¹¹¹In]-
DTPA and [⁶⁷Ga]-DTPA in, 202
pathologic mechanisms altering, 248, 250
- Clinical testing, new drug (see also Investigational new
drugs), 358-361, 360-361
- Clofibrate, radioxenon interactions with, 211
- Codeine, hepatobiliary imaging and, 184
- Colchicine
phagocytosis and, 174
radiocyanocobalamin interactions with, 209-210
- Collagen degradation, 176
- Collimator selection, 294-295, 295-295
- Colloids
¹⁹⁸Au, 86
heparin effects on uptake of, 172
impurities in, 268, 269
^{99m}Tc-labeled (see ^{99m}Tc-labeled colloids)
- Coma, hepatic, animal models of, 341t
- Commercial source, formulation problems related to,
278-279
- Compartmental analysis (see Radiopharmacokinetics)
- Complement system, 172-173
- Compliance problems, 328-329, 328t
- Computed tomography (see Emission computed tomogra-
phy; Single photon emission computed tomogra-
phy)
- Computer(s)
applications of, 145-160
basics of, 145-150, 146-148, 149t
central processing unit of, 149-150
data storage, 149
display devices, 147, 149
inputs to, 145-147, 146-148
laboratory uses of, 160
memory in, 146, 149t, 150
output devices, 147-150, 146
scintigraphic, clinical uses for, 150-160
system bus, 146, 149, 150
con A (see Concanavalin A)
- Concanavalin A (con A), 178-179
- Conditional probabilities, 133-134
- Congestive heart failure, 256
- Consultant, concept of diagnostic imager as, 395
- Consultation service, 389-396
- Contamination
computer analysis of, 160
formulation problems related to, 283-284
- Continuing education, 409
- Contraceptives, oral (see Oral contraceptives)
- Contrast agents
iodide interactions with, 204t
iodinated
renal function radiotracer interactions with, 218
^{99m}Tc-labeled red blood cell interactions with, 201
lymphangiographic, [⁶⁷Ga]gallium citrate interactions
with, 212
- Coronary artery disease, myocardial perfusion imaging and,
154, 156-157, 156, 158
- Corticosteroids
brain-imaging radiotracer interactions with, 217
¹¹¹In-labeled leukocyte interactions with, 203
^{99m}Tc-labeled phosphate and phosphonate interactions
with, 196
- Cost
monitoring, 108-109, 109t
selection of radiopharmaceutical and, 82
- CPU (see Central processing unit)
- CPZ (see Chlorpromazine)
- ⁵¹Cr-labeled platelets, 15
- ⁵¹Cr-labeled red blood cells
clinical utility of, 91
preparation of, 90-91, 91t
- Crystal hydration, field uniformity and, 292
- Cyclic adenosine monophosphate (cAMP)
cardiac function and, 181
ethanol and benzyl alcohol effects on, 180
pinocytosis and, 170
reticuloendothelial system-imaging agents and, 173
- Cyclic nucleotide, intracellular concentration of, 168
- Cyclohexamide, radiocyanocobalamin interactions with,
209-210
- Cyclophosphamide
brain-imaging radiotracer interactions with, 216-217
^{99m}Tc-labeled phosphate and phosphonate interactions
with, 194
- Cyclosporine, renal function radiotracer interactions with,
218
- Cyst(s)
intracranial, 248
ovarian, 251, 251t
- Cytochalasin E, 178-179
- Cytochrome P-450, 44
- Dactinomycin
brain-imaging radiotracer interactions with, 216-217
radiocyanocobalamin interactions with, 209-210
- Decay mode, selection of radiopharmaceutical and, 75-76,
76t
- Decision analysis, 139-142, 140-142
- Decision making, 133-134
Bayes' theorem in, 137-139, 138t
probabilities in, 133-134, 134t
- Decision matrix, 134-137, 134t, 135-136
- Decision tree, 139-142, 140-142
- Decomposition, radiolytic, formulation problems related to,
279-280
- Defibrillation, ^{99m}Tc-pyrophosphate uptake and, 228, 228t
- Department of Transportation (DOT), regulatory authority
of, 327
- Dexamethasone suppression, 116-117, 117
- Dextran, [⁶⁷Ga]gallium citrate affected by, 179
- Diabetes, animal models of, 343, 344t
- Diagnosis, radiopharmacokinetics and, 26
- Dialysis
complement activity and, 173
radiopharmaceutical biodistribution and, 230
^{99m}Tc-pertechnetate, 170-171
- Diazepam, radioxenon interactions with, 211

- Dicopac Schilling test, 282–283
- Diethylenetriaminepentaacetic acid (DTPA) (*see* ¹¹¹In-diethylenetriaminepentaacetic acid; ^{99m}Tc-diethylenetriaminepentaacetic acid)
- 2,6-Diethyliminodiacetic acid, normal biodistribution of, 8–9
- Diethylstilbestrol
[⁶⁷Ga]gallium citrate interactions with, 212–213
^{99m}Tc-labeled phosphate and phosphonate interactions with, 196
- Digestive system (*see* entries beginning with Gastrointestinal)
- Digital imaging (*see* Computer(s); specific site)
- Digitalis, calcium ion and, 181
- Digoxin
⁴¹K and, 181
radioassay, 101–102, 103r
^{99m}Tc-labeled red blood cell interactions with, 201
- Dihydroachysterol, radiotracer uptake and, 176
- Diiodotyrosine, 12
- Diphosphonate, ^{99m}Tc-labeled phosphate and phosphonate interactions with, 193, 197
- Diphosphonate ligand, ^{99m}Tc-labeled bone-imaging agent, structure of, 41, 41
- Dipyridamole, cardiac imaging and, 117–119, 118, 182–183, 416
- Disease
animal models of, 333–347
biodistribution and absorbed dose and, 69–70
chronic, stages in, 99, 100
monitoring of, 104r
radiotracer uptake and, 166
- DISIDA (*see* ^{99m}Tc-diisopropyl-substituted iminodiacetic acid)
- Diuretics (*see also* Renal imaging; specific diuretic), [¹²⁵I]iodomethylnorcholesterol interactions with, 205–206
- Diverticulum, Meckel's (*see* Meckel's diverticulum)
- DMSA (*see* ^{99m}Tc-dimercaptosuccinic acid)
- Dogs, cardiovascular models with, 334–336
- Dose (*see also* Absorbed dose)
calibration of, impurities affecting, 283
pediatric (*see* Pediatric patient)
- Dosimetry
calculations, 23–24, 24, 24r, 51–72
pregnancy and, 64
- DOT (*see* Department of Transportation)
- Double exposure, 292, 293
- Doxorubicin
brain-imaging radiotracer interactions with, 216–217
cardiotoxicity of, 181–182
^{99m}Tc-labeled phosphate and phosphonate interactions with, 194, 197
^{99m}Tc-labeled red blood cell interactions with, 202
[²⁰¹Tl]thallous chloride interactions with, 209
- Drug history (*see also* Patient preparation), thyroid studies and, 412
- Drug interactions, absorbed dose and, 71
- Drug intervention, 115–129
absorbed dose and, 71
- Drug receptors, radiotracer uptake and, 166
- Drug therapy
monitoring of, 99–113, 104r
radioisotopes as pharmacodynamic tracers of, 105–106
- Drug-radiopharmaceutical interactions (*see also* specific agent), 165–184
reported instances of, 189–219
theoretical considerations, 165–184
- DTPA (*see* Diethylenetriaminepentaacetic acid)
- Economics of monitoring, 108–109, 109r, 111r
- ECT (*see* Emission computed tomography)
- Education (*see also* Patient education), continuing, 409
- Effective thyroid ratio (ETR), probabilities of, 134r
- Efficiency of nuclear medicine study, 395
- Ehrlich ascites, animal models of, 346r
- Ejection fraction, 151
- Embolism, pulmonary (*see* Pulmonary embolism)
- Emission computed tomography (*see also* Single photon emission computed tomography), imaging problems in, 298–300, 299r
- Emphysema, animal models of, 338, 339r
- Encapsulation, formulation problems related to, 282
- Encephalitis, animal models of, 336, 338r
- Endocarditis, animal models of, 336, 337r
- Environmental Protection Agency (EPA), regulatory authority of, 327, 327
- Enzyme substrate, 34–35
- Enzymes (*see also* specific enzyme)
drug effects on, radiotracer biodistribution and, 169
nonmicrosomal versus microsomal, 44
- EPA (*see* Environmental Protection Agency)
- Ependyoblastoma, animal models of, 346r
- Epilepsy, animal models of, 336, 338r
- Epinephrine, spleen imaging and, 127, 129
- Erythrocytes (*see* Red blood cells)
- Erythromycin, [⁶⁷Ga]gallium citrate interactions with, 214–215
- Esophagitis
animal models of, 340r
induced by irradiation, 226
- Estrogens
plasma proteins stimulated by, 178
reticuloendothelial system affected by, 174
^{99m}Tc-labeled phosphate and phosphonate interactions with, 196
- Ethanol, [⁶⁷Ga]gallium citrate and, 180
- ETR (*see* Effective thyroid ratio)
- Europe
adverse reaction reporting in, 308–309, 310
adverse reaction statistics in, 312–313, 313r
- Excretion
rate of, selection of radiopharmaceutical and, 80
route of, selection of radiopharmaceutical and, 79
- Exercise tolerance test (*see* Stress testing)
- Expected utility, 140–143, 141–143
- Expectorants, iodide interactions with, 204, 204r
- Fasting, hepatobiliary imaging and, 417
- FDA (*see* Food and Drug Administration)
- ⁵⁹Fc, fetal dose of, 65–66
- Fetus, radiation risks to, 64–69, 68r
- Fibrinogen (*see* ¹²⁵I-fibrinogen)
- Field flood phantoms, problems with use of, 291, 291r, 292, 294
- Field uniformity, 292
- Follicular carcinoma, sodium [¹³¹I]iodide for, 88
- Food and Drug Administration (FDA)
adverse reactions and, 303–310
investigational new drugs and
 application processing and, 55–56, 364–367, 366
 guidelines for, 54–55, 357
 regulatory authority of, 53, 326–327, 327
 clinical testing of new drugs and, 358–360
- Formulation, selection of radiopharmaceuticals and, 81–82, 81r
- Formulation errors, absorbed dose and, 70
- Formulation problems, clinical manifestations of, 268–284, 271r–273r
- Fourier analysis, cardiac contraction and, 154
- Fracture, animal models of, 334, 335r
- Frame mode acquisition, 146, 148
- Free pertechnetate
absorbed dose and, 70
distribution of, 268, 269
- Furosemide (Lasix)
[⁶⁷Ga]gallium citrate interactions with, 214–215
renal function radiotracer interaction with, 219
renal imaging and, 119–120, 121r
- [⁶⁷Ga]gallium citrate
adverse reactions to, 315r
dose to breastfeeding newborn, 63, 63r
drug interactions with, 178–180, 211–216
fetal dose of, 65, 67
¹¹¹In-labeled leukocytes versus, abscess imaging and, 79
lactation and, 59, 60r
metabolism of, 45
normal biodistribution of, 14–15, 14
pediatric use of, 57
tumor and abscess localization with, patient preparation for, 414
uptake of
 normal variations in, 244–245
 pathologic mechanisms altering, 262–263, 263
- Gallbladder (*see* entries beginning with Hepatobiliary)
- Gallium nitrate, [⁶⁷Ga]gallium citrate interactions with, 213
- Gamma camera, 146, 147
imaging with, exercise tolerance test and, 154, 156, 156r
proper setting of, 295–296
tomographic reconstruction of images from, 159–160
- Gamma emission, principal, selection of radiopharmaceutical and, 75–76, 76r
- Gases, radiopharmaceutical
metabolism of, 45
regulatory control of, 329
- Gastric emptying studies, 122–123
radiopharmaceuticals for, drug interactions with, 216
- Gastroenteritis, animal models of, 340r
- Gastroesophageal reflux, interventional studies of, 120, 122
- Gastrointestinal bleeding
animal models of, of, 340r
diagnosis of
 ¹¹¹In-labeled platelets in, 96
 ^{99m}Tc-labeled red blood cells in, 91–92
 interventional studies of, 123–124
 radiopharmaceutical efficacy and, 111
- Gastrointestinal disease, animal models of, 338–339, 340r
- Gastrointestinal imaging
¹¹¹In-labeled leukocytes in, 95
pathologic mechanisms altering, 254–258, 254–256
^{99m}Tc-labeled red blood cells in, drug interactions with, 201
- Gastrointestinal tract, therapeutic irradiation of, radiotracer distribution affected by, 226
- Gated blood pool imaging (*see* Blood pool imaging)
- Gated ventriculography (*see also* Blood pool imaging), 151–154, 151–153, 155
- Gaviscon, gastroesophageal reflux and, 122
- Genitourinary disease, animal models of, 341–342, 342r
- Genitourinary imaging, pathologic mechanisms altering, 258–260
- Gentamicin, ^{99m}Tc-labeled phosphate and phosphonate interactions with, 194
- Gentisic acid, effects on ^{99m}Tc-labeled radiopharmaceuticals of, 81, 81r
- GFR (*see* Glomerular filtration rate)
- GH (*see* Glucate (glucoheptonate))
- Glioma, animal models of, 346r
- Glomerular filtration rate (GFR)
computer assessment of, 159, 160
DTPA and, 4
- Glomerulonephritis, animal models of, 342, 342r
- Glucagon
gastrointestinal bleeding studies with, 123–124
Meckel's diverticulum detection and, 125, 415
- Glucate (glucoheptonate) (GH) (*see* ^{99m}Tc-glucate)
- Glucate, agents containing, 177
- Glucose
¹⁴C-labeled, sperm metabolism assessed by, 103, 103r
cardiac, effects on radiotracer uptake of, 183
- Glucose tolerance factor (GTF), 45–46
- Glycoenzymes, 167
- Glycogenolysis, ischemia and, 181
- Glycols, effects on radiotracer distribution, 176–177
- Glycopyrrolate, pertechnetate uptake and, 169
- Goiter, toxic multinodular, sodium [¹³¹I]iodide for, 88
- Gold salts, [⁶⁷Ga]gallium citrate interactions with, 214–215
- Government (*see* Regulations; entries beginning with Regulatory)
- Granulomatosis, radiogallium and, 229–230
- Graves' disease, 116
sodium [¹³¹I]iodide for, 88
- Groin, clinical variations in, radiopharmaceutical biodistribution and, 244
- GTF (*see* Glucose tolerance factor)
- Half-life, selection of radiopharmaceutical and, 75, 76r
- Hansch hypothesis, 33, 37
- Hashimoto's thyroiditis, 116

- Hazards (see Radiation hazards)
- HEDP (see ^{99m}Tc -hydroxymethylene diphosphonate)
- Heart (see also entries beginning with Cardiac; entries beginning with Myocardial)
- clinical variations in, radiopharmaceutical distribution and, 243, 243r
 - dog versus human, 335
 - therapeutic irradiation of, radiotracer distribution affected by, 220, 221
- Heart beat, multiple-gated imaging of, 153–154, 153r
- Heart wall, motion of, 154
- Heating, formulation problems caused by, factors in, 276–277
- Heavy metals, thyroid-imaging effects of, 184
- HEDP (see Hydroxyethylidene diphosphonate)
- Hematological disease, animal models of, 345, 345r
- Hematological effects, sodium [^{32}P]phosphate, 85
- Hematoma, subdural, animal models of, 336, 338r
- Hemodialysis
- complement activation and, 173
 - pertechnetate distribution and, 170–171
- Hemolytic anemia, animal models of, 345, 345r
- Hemorrhage, gastrointestinal (see Gastrointestinal bleeding)
- Heparin, 281
- ^{67}Ga]gallium citrate interactions with, 215–216
 - ^{111}In -labeled platelet interactions with, 203–204
 - reticuloendothelial system affected by, 172
 - ^{99m}Tc -labeled macroaggregated albumin and albumin microsphere interactions with, 198–199
 - ^{99m}Tc -labeled phosphate and phosphonate interactions with, 195
 - ^{99m}Tc -labeled red blood cell interactions with, 201
- Hepatic artery infusion chemotherapy, interactions with ^{99m}Tc -labeled iminodiacetic acid derivatives, 192–193
- Hepatic coma, animal models of, 341r
- Hepatic function, measurement of, characteristics of ideal breath test substrate for, 112, 112r
- Hepatitis, neonatal, biliary atresia versus, 126
- Hepatobiliary disease, animal models of, 339–341, 341r
- Hepatobiliary imaging
- drug-radiopharmaceutical interactions affecting, 184
 - ^{99m}Tc -labeled iminodiacetic acid derivatives in, 192–193
 - patient preparation for, 417
 - reticuloendothelial system imaging versus, 77
 - selection of radiopharmaceutical for, 80, 80r
 - structure-distribution relationships of agents for, 38–41, 39–41r
 - ^{99m}Tc -labeled iminodiacetic acid derivative, 8–10, 10r, 26, 27–28
- Hepatobiliary system, interventional studies of, 125–127, 128
- Hepatocytes, 77
- Hepatoma, animal models of, 346r
- Hippuran, ^{131}I -labeled (see *o*-[^{131}I]iodohippurate)
- Hodgkin's disease, 127
- Hormone receptors, cell membrane effects of, 168
- HPLC (see Chromatography, high-performance liquid)
- Human albumin (see ^{99m}Tc -labeled albumin)
- Human experimentation, checklist for, 108r
- Hyaline membrane disease, animal models of, 338, 339r
- Hydralazine, ^{99m}Tc -labeled red blood cell interactions with, 201
- Hydrocephalus, 248–249, 250
- animal models of, 336, 338r
- Hydrochlorothiazide, [^{67}Ga]gallium citrate interactions with, 214–215
- Hydroxyapatite, pyrophosphate and, 175
- Hydroxyethylidene diphosphonate (HEDP) (see also ^{99m}Tc -hydroxyethylidene diphosphonate), matrix vesicle functioning and, 175–176
- Hyperaldosteronism, 116, 117r
- Hyperalimentation (see Nutrition, total parenteral)
- Hyperalbuminemia, 170–171
- Hyperbilirubinemia, neonatal, 125
- Hyperlipidemia, [^{67}Ga]gallium citrate and, 179
- Hyperprolactinemia, [^{67}Ga]gallium citrate accumulation and, 179–180
- Hypertension, animal models of, 335, 337r
- pulmonary, 338, 339r
- Hyperthyroidism, 116
- sodium [^{131}I]iodide for, 88
 - thyrotropin-releasing hormone infusion test and, 116
- Hyposplenism, 226
- Hypothesis, research, 106
- Hypothyroidism, primary versus secondary, 116
- ^{125}I -fibrinogen
- lactation and, 60–61, 60r
 - normal biodistribution of, 13
 - thrombus localization with, patient preparation for, 414–415
- ^{131}I -hippuran (see *o*-[^{131}I]iodohippurate)
- ^{131}I -labeled agents (see also Radioiodides; Sodium [^{131}I]iodide)
- indotricarbocyanine, structure of, 40–41, 40–41r
 - m*-[^{131}I]iodobenzylguanidine (mIBG)
 - drug interactions with, 206–207
 - metabolism of, 48–49
 - structure of, 34–35, 34r
 - p*-[^{125}I]iodobenzylguanidine (pIBG), metabolism of, 48–49
 - 19-[^{131}I]iodocholesterol, adrenal imaging with, 116
 - o*-[^{125}I]iodohippurate
 - normal biodistribution of, 12
 - renal function studies with, patient preparation for, 415–416
 - o*-[^{131}I]iodohippurate (hippuran)
 - metabolism of, 48
 - normal biodistribution of, 12
 - renal function studies with, patient preparation for, 415–416
 - renogram with, 26
 - abnormal, 30
 - furosemide and, 120
 - normal, 29
 - 6 β -[^{131}I]iodomethylnorcholesterol (NP-59)
 - adrenal imaging with, 116, 117, 117r
 - adverse reactions to, 317
 - drug interactions with, 205–206
 - metabolism of, 48
 - normal biodistribution of, 12
 - Ibuprofen, [^{67}Ga]gallium citrate interactions with, 214–215
 - IDA derivatives (see Iminodiacetic acid derivatives)
 - Image degradation, radionuclidic impurities and, 283–284
 - Iminodiacetic acid (IDA) derivatives (see ^{99m}Tc -labeled iminodiacetic acid derivatives; specific derivative)
 - Immunotherapy, radiopharmaceutical biodistribution and, 229–230
 - In situ preparation, ease of, selection of radiopharmaceutical and, 82
 - In utero exposure, 64–69
 - ^{11}In -diethylenetriaminepentaacetic acid (DTPA)
 - adverse reactions to, 317
 - drug interactions with, 202
 - metabolism of, 45
 - ^{111}In -labeled leukocytes
 - clinical utility of, 94–95
 - drug interactions with, 203
 - [^{67}Ga]gallium citrate versus, abscess imaging and, 79
 - normal biodistribution of, 15
 - preparation of, 92–94, 93r
 - ^{111}In -labeled platelets
 - clinical utility of, 95–96
 - drug interactions with, 203–204
 - normal biodistribution of, 15
 - preparation of, 95, 96r
 - ^{111}In -oxine, metabolism of, 45
 - ^{111}In -oxine-labeled red blood cells, preparation of, 90
 - ^{111}In -tropolone-labeled leukocytes, preparation of, 94, 94r
 - [^{111}In]indium chloride
 - metabolism of, 45
 - nuclear properties of, 76r
 - [^{111}In]indium chloride
 - fetal dose of, 66–67
 - metabolism of, 45
 - Incubation, formulation problems related to, 277
 - IND (see Investigational new drugs)
 - Indotricarbocyanines, ^{131}I -labeled, structure of, 40–41, 40–41r
 - Infants (see also Newborn)
 - brain imaging of, 236
 - breastfeeding, radiation dose to, 62–64
 - lung perfusion imaging in, 82
 - Infarction
 - cerebral, animal models of, 336
 - myocardial (see Myocardial infarction)
 - Infection, bone and joint, ^{111}In -labeled leukocytes for diagnosis of, 95
 - Inflammatory process imaging, ^{111}In -labeled leukocytes in, 15
 - drug-radiopharmaceutical interactions and, 203
 - Information centers, 389–396
 - Injection
 - errors in, absorbed dose and, 70–71
 - intramuscular, [^{67}Ga]gallium citrate interactions with, 214
 - Instrumentation, problems with, 290–300
 - Insulin, cardiac radiotracer effects of, 183
 - Interventional studies, 115–129
 - Interventricular system, paradoxical motion of, 251
 - Intestinal tract (see also entries beginning with Gastrointestinal); free pertechnetate in, 268, 269
 - Intracranial cysts, 248
 - Intramuscular injection, [^{67}Ga]gallium citrate interactions with, 214
 - Intravascular coagulopathy, animal models of, 345, 345r
 - Intubation, radiotracer biodistribution and, 229
 - Invasive procedures, absorbed dose and, 71
 - Investigational new drugs (INDs)
 - application for, 53, 54, 55
 - avoiding delays in processing of, 364–367, 366r
 - considerations in, 357–372, 374–385
 - examples of situations requiring, 367–372
 - forms for, 374–379
 - framework and criteria for review of, 361–362
 - participants in process of, 357–358
 - submission instructions for, 361
 - clinical trials of, 55, 358–361, 360–361r
 - three phases of, 360–361, 360–361r
 - Medical Review Guidelines for, 361, 380–385
 - physician-sponsored
 - clinical trials of, 359
 - problem areas with, 362–364
 - requirements for, 54–55
 - sample size and, 363
 - study design for, 363–364
 - Investigational studies, 105–107, 108r
 - hypothesis in, 106
 - prognostic effectiveness of, 107
 - reporting of, 107–108
 - research design of, 106–107
 - Iodides (see also Radioiodides; Sodium [^{131}I]iodide), drugs
 - containing, thyroid-imaging effects of, 184
 - Iodinated contrast agents, renal function radiotracer interactions with, 218
 - Iodinated serum albumin, fetal dose of, 66
 - Iodination, 12
 - Iodine metabolism, 46
 - p*-Iodoiminodiacetic acid, 8
 - Iron (see also ^{59}Fe)
 - effects on radiotracer distribution, 176, 177r
 - [^{67}Ga]gallium citrate interactions with, 213
 - ^{99m}Tc -labeled phosphate and phosphonate interactions with, 193–194
 - Iron dextran
 - [^{67}Ga]gallium citrate and, 180
 - radiotracer distribution and, 177
 - ^{99m}Tc -labeled phosphate and phosphonate interactions with, 195
 - Iron hydroxide precipitates, adverse reactions to, 316
 - Irradiation (see also entries beginning with Radiation), therapeutic, radiotracer biodistribution altered by, 220–226
 - Ischemia, myocardial, 118, 119, 154
 - cyclic adenosine monophosphate and, 181
 - myocardial infarction versus, 157

- Isoproterenol
effects on sperm, 103, 103r
gastric emptying radiotracer interactions with, 216
- Isotope exchange, formulation problems related to, 282–283
- Isotopically substituted biochemicals, 34
- Jaszczak phantom, 299, 299
- Jaundice, animal models of, 341r
- JCAH (see Joint Commission on Accreditation of Hospitals)
- Joint Commission on Accreditation of Hospitals (JCAH), license inspection by, 325
- Joint infections, ¹¹¹In-labeled leukocytes in detection of, 95
- ⁴³K, digoxin effects on, 181
- Ketosis, [⁶⁷Ga]gallium citrate and, 179
- Kidney (see also entries beginning with Renal)
clinical variations in, radiopharmaceutical biodistribution and, 239–243, 242
interventional studies in, 119–120, 121
scintigraphic computers in, 157, 159
therapeutic irradiation of, radiotracer distribution and, 221
- Kinetics (see Radiopharmacokinetics)
- Kinevac (see Sincalide)
- ^{81m}Kr
in children, 57
metabolism of, 45
- Kupffer cells, 77
- Labeling
commercial source and, 278
oxidation and, 279
- Lactation
dose estimation during, 61–64
radiation hazards during, 59–64, 239
- Lactoferrin, [⁶⁷Ga]gallium citrate and, 178
- Lasix (see Furosemide)
- Lesions (see also Tumor), peripelvic, 242
- Leukemia, animal models of, 346r
chronic myelogenous, 345, 345r
- Leukocytes
damage to, monitoring causing, 110
function of, [⁶⁷Ga]gallium citrate distribution and, 178
¹¹¹In-labeled
clinical utility of, 94–95
drug interactions with, 203
normal biodistribution of, 15
preparation of, 92–94, 93r
¹¹¹In-tropolone-labeled, preparation of, 94, 94r
- Leukopenia, [⁶⁷Ga]gallium citrate and, 178
- Leukotoxine, 15
- Levodopa, gastric emptying radiotracer interactions with, 216
- Librax, gastric emptying radiotracer interactions with, 216
- License amendments, 324
- License inspections, 324–325
- License renewal, 324
- Licensing, radioactive materials, 321–324, 324r–325r, 329
- Licensing agencies, 322r–323r
- Licensing states, 53, 332r–333r
- Lidocaine
¹¹¹In-labeled leukocyte interactions with, 203
[²⁰¹Tl]thallous chloride interactions with, 209
- Ligand concentration, formulation problems and, 276
- Limited-angle tomography, 159–160
- Lipid permeability, drug effects on radiotracer distribution and, 167
- Lipophilicity
Hansch equation and, 33
structure-distribution relationships and, 37, 38
- Liposome-cell interactions, cell membrane effects of, 168–169
- List mode acquisition, 146, 148
- Liver (see also entries beginning with Hepatic)
clinical variations in, radiopharmaceutical biodistribution and, 234, 235, 236r
colloidal impurities in, 268, 269
therapeutic irradiation of, radiotracer distribution affected by, 221, 222
- Liver imaging
drug-radiopharmaceutical interactions affecting, ^{99m}Tc-labeled colloids in, 190–191
particulate impurities in, 268, 270
selection of radiopharmaceutical for, 77
^{99m}Tc-labeled iminodiacetic acid derivatives in, 9–10
^{99m}Tc-labeled sulfur colloid in, 7
- Liver uptake, bone imaging agent, factors associated with, 393r
- LLW disposal (see Low-level radioactive waste disposal)
- Low-level radioactive waste (LLW) disposal
in-house radiopharmacy and, 325
regulation of, 325, 326r
unit dose radiopharmaceutical supplier and, 325–326
- Lung (see also entries beginning with Pulmonary)
chronic obstructive disease of, 78
clinical variations in, radiopharmaceutical biodistribution and, 243–244, 244r
particulate impurities in, 268, 270
pathology, animal models of, 336–338, 339r
therapeutic irradiation of, radiotracer distribution affected by, 221
- Lung imaging
pathologic mechanisms altering, 252–254, 253
selection of radiopharmaceutical for, 78, 81–82
^{99m}Tc-labeled macroaggregated albumin, 5, 6
- Lung ventilation and perfusion studies
radioaerosol, 78
scintigraphic computer in, 157
¹³³Xe, 15–16, 16, 78
- Lymph nodes, therapeutic irradiation of, radiotracer biodistribution affected by, 226
- Lymphangiography, contrast media for, [⁶⁷Ga]gallium citrate interactions with, 180, 212
- Lymphocytes, [⁶⁷Ga]gallium citrate and, 178
- Lymphoma, [⁶⁷Ga]gallium citrate in, 178
- Lymphoscintigraphy, ^{99m}Tc-labeled antimony sulfide colloid, 6–7
- Lysosomal enzymes, collagen degradation and, 176
- Lysosomes, [⁶⁷Ga]gallium citrate in, 179
- MAA (see Albumin, macroaggregated)
- Malignant effusion, chronic [³²P]phosphate for, 86, 87
- Mannitol, ^{99m}Tc-DMSA interactions with, 197–198
- Matrix, decision, 134–137, 134r, 135–136
- Maximum permissible dose (MPD), 329
- Mefenofen, structure of, 38, 39
- Mechlorethamine, [⁶⁷Ga]gallium citrate interactions with, 213
- Meckel's diverticulum
anatomic variants simulating, 244
drug-radiopharmaceutical interactions affecting imaging of, ^{99m}Tc-pertechnetate in, 199
interventional studies of, 124–125
patient preparation for imaging of, 415
- Medical Internal Radiation Dose (MIRD), 54–55
- Megavoids, 392–393
- Melanoma, animal models of, 346r
- Membrane permeability (see Cell membrane)
- Meningitis, aseptic and septic, animal models of, 336, 338r
- Meperidine, ^{99m}Tc-labeled phosphate and phosphonate interactions with, 195
- Metastases
bone, 259, 260
sodium [³²P]phosphate for, 85, 86
brain, 248, 249
effusions caused by, chronic [³²P]phosphate for, 86, 87
- Metabolic bone disease, animal models of, 335r
- Metabolic disorders, animal models of, 345
- Metabolic reactions
nonmicrosomal versus microsomal, 44
nonsynthetic versus synthetic, 44
- Metabolic trapping, 35
- Metabolism, radiopharmaceutical, 44–49
- Methicillin, [⁶⁷Ga]gallium citrate interactions with, 214–215
- Methotrexate, 180
brain-imaging radiotracer interactions with, 216–217
[⁶⁷Ga]gallium citrate interactions with, 213
- Methylodopa, ^{99m}Tc-labeled red blood cell interactions with, 201
- Methylprednisolone, cardiology and, 181
- 5-Methyltryptophan, pyridoxylamine of, structure of, 40, 40
- Metoclopramide
[⁶⁷Ga]gallium citrate interactions with, 212–213
gastric emptying studies with, 122–123
side effects of, 123
- mIBG (see m-[¹³¹I]iodobenzylguanidine)
- Michaelis-Menten kinetics, 23, 23
- Microembolism, cerebral, animal models of, 336, 338r
- Microprocessor, 149–150
- MIRD (see Medical Internal Radiation Dose)
- Mixed function oxidases, 44
- Mixing order, formulation problems and, 275–276
- Molecular size
drug effects and, 33
drug excretion and, 37
structure-distribution relationships and, 37
- Molecular structure, drug excretion and, 37, 38, 39
- Molecular weight, drug excretion and, 37, 38, 39
- Monitoring
capabilities of, 104, 104r
concept of radiotracers in, 100–104
economics of, 108–109, 109r
in vitro, 102–103, 103r
multidisciplinary approach to therapy and, 101, 102
pitfalls and problems in, 112–113, 112r, 113
preclinical testing of, 110
procedures for, 99–100
relative efficacy of, 109–112
reporting of, omissions in, 113
research and scientific basis of, 106–108, 108r
- Moniodotyrosine, 12
- Morphine
gastric emptying radiotracer interactions with, 216
hepatobiliary imaging and, 184
- MPD (see Maximum permissible dose)
- Multidisciplinary approach to therapy, 101, 102
- Multiple myeloma, 248
- Multiple-gated acquisition (MUGA)
blood pool study from, 151
cardiac function and, 153–154, 153
- Musculoskeletal imaging (see also Bone; entries beginning with Skeletal), pathologic mechanisms altering, 257–262, 260–262
- Myelofibrosis, animal models of, 345, 345r
- Myocardial imaging, 118, 118
- Myocardial infarction, 118, 118, 154
animal models of, 334, 337r
ischemia versus, 157
^{99m}Tc-labeled phosphate imaging of, 8
- Myocardial ischemia, 154
cyclic adenosine monophosphate and, 181
myocardial infarction versus, 157
- Myocardial necrosis, animal models of, 334, 337r
- Myocardial perfusion imaging, 154, 156–157, 157
drug-radiopharmaceutical interactions affecting, [²⁰¹Tl]thallous chloride in, 207–209
patient preparation for, 416, 416r
- Myocardopathy, animal models of, 337r
- Myocarditis, animal models of, 336, 337r
- Narcotic analgesics
gastric emptying radiotracer interactions with, 216
^{99m}Tc-labeled iminodiacetic acid derivative interactions with, 191–192
- Nasogastric intubation, radiotracer biodistribution and, 229
- National Center for Drugs and Biologics, organization of, 336
- National Council on Radiation Protection and Measurement (NCRP), 321
radioactive patient and, 328, 328r
- NDA (see New drug application)
- Neomycin, radiocyanocobalamin interactions with, 209–210
- Nervous system (see Central nervous system)
- Neurological disease (see also specific disease), animal models of, 336, 338r

- Neutropenia, cyclic, animal models of, 345, 345r
- New drug application (NDA) (*see also* Investigational new drugs), 55–56
- approval time of, 46
- Newborn (*see also* Infants)
- breastfeeding, radiation dose to, 62–64
- hepatitis versus biliary atresia in, 126
- hyperbilirubinemia in, 125
- lung perfusion imaging in, 82
- Nicotinic acid, ^{99m}Tc-labeled iminodiacetic acid derivative interactions with, 192
- Nitrates
- ^{99m}Tc-labeled red blood cell interactions with, 199–200
- [²⁰¹Tl]thallous chloride interactions with, 207–208
- Nitrofurantoin, [⁶⁷Ga]gallium citrate interactions with, 212
- Nitroglycerin, cardiac imaging and, 119
- Nitrosoureas, ^{99m}Tc-labeled colloid interactions with, 190
- Noncompliance, nuclear medicine monitoring in assessment of, 100
- NP-59 (*see* 6β-[¹²⁵I]iodomethylnorcholesterol)
- Nuclear medicine professionals, information needed by, 389–392, 391r–393r
- Nuclear Regulatory Commission (NRC), 321
- ALARA and, 329
- authority of, 326–327, 327r
- licensing and, 322–324
- radioactive patient and, 328
- responsibilities of, 53–54
- Nutriton (*see also* Total parenteral nutrition), reticuloendothelial system affected by, 174
- Objective probabilities, 133
- Occupational exposure, 329
- Occupational Safety and Health Administration (OSHA), regulatory authority of, 327
- OIH (*see* *o*-[¹³¹I]iodohippurate; *o*-[¹²⁵I]iodohippurate)
- Oncology (*see also* Cancer), animal models of, 346–347, 346r
- Opsonin, 172
- Opsonization, 172, 173
- Oral contraceptives
- [⁶⁷Ga]gallium citrate interactions with, 212–213
- [¹²⁵I]iodomethylnorcholesterol interactions with, 206
- radiocyanocobalamin interactions with, 209–210
- Organification, 12
- Organogenesis, 68r
- OSHA (*see* Occupational Safety and Health Administration)
- Osteomalacia, animal models of, 335r
- Osteomyelitis, 259
- animal models of, 335r
- Osteoporosis, 257
- animal models of, 334, 335r
- Ovarian cyst, 251, 251r
- Oxidases, mixed function, 44
- Oxidation
- formulation problems related to, 279–280
- iodine volatility and, 283
- Oxyquinoline (*see* [¹¹¹In]-oxine)
- ³²P (*see also* Chromic [³²P]phosphate; Sodium [³²P]phosphate), chlorpromazine and, 168
- Package insert, 56
- Paget's disease, 176
- Pancreas
- clinical variations in, radiopharmaceutical biodistribution and, 236
- disease of, animal models of, 338–339
- imaging of
- patient preparation for, 414
- [⁷⁵Se]selenomethionine, 15
- Papillary carcinoma, sodium [¹³¹I]iodide for, 88
- Parallel-line equal-spacing (PLES) phantom, 294
- Parathyroid hormone (PTH), radiotracer excretion and, 176
- Parathyroid imaging, patient preparation for, 415
- Particulate size and number, formulation problems related to, 277–278
- Partition coefficient, in Hansch equation, 33
- Pathologic mechanisms, altered biodistribution caused by, 248–263
- Patient, radioactive, compliance problems with, 327–328, 328r
- Patient education, 404–409, 411
- definition of, 404
- future of, 409
- team approach to, 408
- theoretical approaches to, 405–408
- Patient positioning, 297
- Patient preparation, 411–418
- bone imaging, 413
- brain and cerebral perfusion imaging, 413–414
- hepatobiliary imaging, 417
- Meckel's diverticulum imaging, 415
- myocardial perfusion imaging, 416, 416r
- nonthyroid imaging with radioiodine, 413
- orally administered radiopharmaceuticals and, 417
- pancreas imaging, 414
- parathyroid imaging, 415
- pediatric, 412
- renal imaging, 415–416
- requirements for, selection of radiopharmaceutical and, 82
- single photon emission computed tomography, problems with, 299–300
- thrombus localization, 414–415
- thyroid imaging, 412
- tumor and abscess localization, 414
- Patient selection, criteria for, investigational new drug application and, 362
- Patient's right to know, 404–405
- Pediatric patient (*see also* Infants)
- absorbed dose estimation in, 56–59
- absorbed dose to
- biologic parameters and, 57–58, 58r
- calculation of, 52
- estimation of, 56–59
- physical parameters and, 56–57
- brain imaging in, 236
- parental preparation for procedures with, 412
- preparation of, 412
- Penicillin, ^{99m}Tc-glucetate interactions with, 197
- Pentagastrin, Meckel's diverticulum imaging and, 124–125, 415
- Pentamidine, [⁶⁷Ga]gallium citrate interactions with, 214–215
- Perchlorate
- brain imaging preceded by, 413
- pertechnetate uptake and, 169–170
- Perfusion (*see* specific type)
- Perfusion defects, 5, 253
- Perfusion imaging, 78, 78r
- kits for, 81–82
- Pericarditis, animal models of, 336, 337r
- Peripelvic lesions, 242
- Peritoneal effusion, chromic [³²P]phosphate for, 86, 87
- Pertechnetate (*see also* Free pertechnetate; ^{99m}Tc-pertechnetate), agents influencing biodistribution of, 165
- aluminum ion, 274
- pH, alterations in, formulation problems caused by, 274–275
- Phagocytosis, intramuscular, reticuloendothelial system and, 171–172
- Phantoms (*see* specific type)
- Pharmacodynamics, radionuclide tracers of, 105–106
- Pharmacokinetics (*see* Radiopharmacokinetics)
- Pharmacologic interventions, 115–129
- Phenazone, [⁶⁷Ga]gallium citrate interactions with, 214–215
- Phenindione, [⁶⁷Ga]gallium citrate interactions with, 214–215
- Phenobarbital
- [⁶⁷Ga]citrate interactions with, 214–215
- hepatobiliary studies with, 125–126
- radiocyanocobalamin interactions with, 209–210
- Phenothiazines, [⁶⁷Ga]gallium citrate interactions with, 212–213
- Phenylbutazone
- [⁶⁷Ga]gallium citrate interactions with, 214–215
- iodide interactions with, 204, 204r
- thyroid imaging effects of, 183
- Phenytoin
- [⁶⁷Ga]gallium citrate interactions with, 211–212, 214–215
- radiocyanocobalamin interactions with, 209–210
- [²⁰¹Tl]thallous chloride interactions with, 209
- Phosphate, radiotracer distribution and, 177
- Phosphatidylinositol content, cellular, 168
- Phospho-Soda
- bone imaging and, 177
- ^{99m}Tc-labeled phosphate and phosphonate interactions with, 193
- Phospholipids, calcium and acidic, 168
- Phosphorus metabolism, 46
- Photopeak efficiency, 76, 76r
- Physical half-life, selection of pharmaceutical and, 75
- Physiologic function, normal variations in, radiopharma-
- ceutical biodistribution and, 234–245
- Pigs, central nervous system models with, 336
- Pinocytosis, 170
- PIPIDA (*see* ^{99m}Tc-*p*-isopropyliminodiacetic acid)
- Placental imaging, ^{99m}Tc-labeled albumin, 11
- Placental transfer, 69
- [⁶⁷Ga]gallium citrate, 65
- [¹¹¹In]indium chloride, 66–67
- iodine, 64, 64r
- ^{99m}Tc-labeled agents, 65
- Planar imaging, problems involving, 291–298
- after imaging, 298, 298r
- during imaging, 297–298, 297r
- prior to imaging, 294–297, 294–295
- Platelets (*see also* [¹¹¹In]-labeled platelets), aggregation of, reticuloendothelial system affected by, 175
- PLES phantom (*see* Parallel-line equal-spacing phantom)
- Pleural effusion, 260, 261
- chromic [³²P]phosphate for, 86, 87
- Plummer's disease, 116
- Polarity
- drug effects and, 33
- drug excretion and, 37
- structure-distribution relationships and, 37
- Polycythemia vera, sodium [³²P]phosphate for, 85, 86
- Polymucositis, [⁶⁷Ga]gallium citrate uptake and, 226
- Positioning, patient (*see also* Patient preparation), 297
- Positron emission tomography, 160
- Positron-emitting radioisotopes, 102
- Posterior probabilities, 134
- Postimaging procedures, 298, 298r
- Potassium
- ²⁰¹K versus, 182
- radiocyanocobalamin interactions with, 209–210
- [²⁰¹Tl]thallous chloride and, 45
- Potassium ion, [⁶⁷Ga]gallium citrate and, 179
- Potassium perchlorate, ^{99m}Tc-pertechnetate preceded by, 4
- Potassium perchlorate test, 116
- Predictive value, test, 135
- Pregnancy
- cautions during, 56
- radiation hazards during, 64–69
- Preimaging procedures (*see also* Patient preparation), 294–297
- Preservatives, formulation problems related to, 281
- Primidone, radiocyanocobalamin interactions with, 209–210
- Prior probability, 133
- Probability
- Bayes' theorem and, 137–139, 138r
- decision making, 133–134, 134r
- Probenecid
- renal function radiotracer interactions with, 219
- ^{99m}Tc-penicillamine and, 184
- Procainamide
- [¹¹¹In]-labeled leukocyte interactions with, 203
- [²⁰¹Tl]thallous chloride interactions with, 209
- Procedural problems, 290–300

- Product formulation, selection of radiopharmaceutical and, 81-82, 81
- Prolactin, [⁶⁷Ga]gallium citrate accumulation and, 179-180
- Propantheline, gastric emptying radiotracer interactions with, 216
- Propranolol
cardiac radiotracer effects of, 182, 183
contraceptive effectiveness of, 103
effects on sperm, 103, 103r
[²⁰¹Tl]thallous chloride interactions with, 207-208, 209
- Propylthiouracil (PTU), 82
cardiac radiotracer effects of, 183
- Prospective payment, radiopharmaceutical information center and, 395
- Prostaglandin E, cyclic adenosine monophosphate and, 174
- Prostheses, radiotracer biodistribution and, 227-228
- Proteins, plasma estrogens and, 178
- Psychotropic drugs
brain-imaging radiotracer interactions with, 217
membrane transport alterations and, 177-178
- PTH (see Parathyroid hormone)
- PTU (see Propylthiouracil)
- Pulmonary abnormalities, complement activation and, 173
- Pulmonary embolism, 78
animal models of, 337-338, 339r
imaging of, drug-radiopharmaceutical interactions affecting, ¹¹¹In-labeled platelets in, 203-204
- Pulmonary fibrosis, idiopathic, animal models of, 338, 339r
- Pulmonary hypertension, animal models of, 338, 339r
- Pulmonary perfusion imaging, 5, 78, 81-82
drug-radiopharmaceutical interactions affecting, ^{99m}Tc-labeled albumin in, 198-199
ventilation imaging versus, 78, 78r
- Pulmonary uptake, ^{99m}Tc-labeled colloid, factors associated with, 392r
- Pulmonary ventilation imaging
drug-radiopharmaceutical interactions affecting, radio-xenon in, 211
perfusion imaging versus, 78, 78r
- PYP (see Pyrophosphate)
- Pyridoxylaminates, structure of, 40, 40
- Pyridoxylidene-phenylalanine, structure of, 40, 40
- Pyrophosphate (PYP)
drug effects on, 175
reagent kit, nonradioactive, adverse reactions to, 315r
- Quality control procedures
patient education and, 409
planar imaging problems during, 291-294, 291-293
- Quinidine, ^{99m}Tc-labeled red blood cell interactions with, 201
- Radiation, nonpenetrating versus penetrating, 56
- Radiation exposure (see also Absorbed dose), general considerations in, 51
- Radiation hazards
age and, 58-59
lactation and, 59-64
monitoring and, 110-111
- occupational exposure as, 329
- Radiation therapy, altered radiopharmaceutical biodistribution as result of, 220-226, 222, 224, 225
- Radioactive Drug Research Committee (RDRC), 55, 365, 368-370
- Radioactive waste disposal (see Low-level radioactive waste disposal)
- Radioaerosols, ^{99m}Tc-DTPA, 78
- Radiocyanocobalamin, drug interactions with, 209-210
- Radiogases, control and licensing of, 329
- Radiohalogenation, structure-distribution relationships and, 36, 40-41, 40-41
- Radiiodides (see also Sodium [¹³¹I]iodide; specific isotope)
fetal dose of, 66, 68-69
metabolism of, 48-49
nonthyroid studies with, patient preparation for, 413
normal biodistribution of, 11-12
pediatric use, 57, 58, 58r
- Radiolabeled metabolic substrates (RMS), sperm motility and, 102-103, 103r
- Radiolytic decomposition, formulation problems related to, 279-280
- Radionuclidic contamination, 283-284
- Radiopertechnetate (see ^{99m}Tc-pertechnetate)
- Radiopharmaceutical information center (RPIC), 389-396
advisability of establishing, 392-394
evolving nuclear medicine concepts relevant to, 395-396
operational aspects of, 396
quality assurance and, 396
- Radiopharmaceutical information resources, 400-403
- Radiopharmaceuticals (see also Radiotracers; specific agent)
absorbed dose considerations, 51-72
adverse reactions to, 303-319
biodistribution and structure in, 33-42
classes of, 34-38, 34, 35r, 38, 44-45
design of
pharmacological approach to, 34
radiopharmacokinetics in, 24-25
drug effects on biodistribution of, 165-184, 189-219
efficacy of, 111-112
inadvertently altered routes of administration of, 230
inventory of, computer, 160
metabolism of, 44-49
normal biodistribution of, 3-16
patient preparation for, 411-418
purchases of, regulations and, 324
selection of, 75-82
substrate-nonspecific, 35r, 37-38, 38
substrate-specific, 34-37, 34, 35r
therapeutic applications of, 84-88
unit dose suppliers of, low-level radioactive waste disposal and, 325-326
- Radiopharmacokinetics
active or nonlinear analysis of, 22-23, 23
basics of, 20-23
diagnosis and, 26
dosimetry calculations and, 23-24
multicompartmental analysis of, 21-22, 22
- passive analysis of, 21-22, 22
radiopharmaceutical design and, 24-25
single compartmental analysis of, 20-21, 21
- Radiopharmacy, in-house, low-level radioactive waste disposal concepts of, 325
- Radiopotassium, normal biodistribution of, 13
- Radiotracers (see also specific agent)
biodistribution of
altered by invasive therapy, 220-230
drug effects on
blood components and, 169
cell membrane and, 166-169
enzymes and, 169
factors determining, 166
iatrogenic alterations in, 165-184
reported instances of drug-induced alterations in, 189-219
cardiac, drug effects on, 180-183
concepts of monitoring with, 100-104
pharmacodynamic studies with, 105-106
- Radioxenon (see ¹³³Xe)
- RDRC (see Radioactive Drug Research Committee)
- Reagent kits, commercial source of, 278-279
- Receiver operating characteristic (ROC) curve, 136, 137
- Receptor-binding biochemicals, 35-37
- Recommendations versus regulations, 321
- Reconstruction parameters, single photon emission computed tomography, 300, 300-301
- Recording media, quality control of, 292
- Red blood cells (see also ^{99m}Tc-labeled red blood cells)
agglutination of, aluminum ion and, 274
radiolabeled
clinical utility of, 91-92
heating in formulation of, 276-277
preparation of, 90-91, 91r
- Reference Man, absorbed dose in, 54
- Registration states, 53
- Regulations
limits imposed by, 327
versus recommendations, 321
- Regulatory agencies (see also Investigational new drugs; specific agency)
federal, state, and local, 326-327, 327
interactions with, 321-326
responsibilities and views of, 53-54
- Regulatory problems, 321-330
- Reidel's lobe, 234
- Renal dialysis (see Dialysis: Hemodialysis)
- Renal failure, animal models of, 341-342, 342r
- Renal imaging, 26, 77-78
abnormal, 30
artifacts in, 296
diuretics in, 119-120, 121
drug-radiopharmaceutical interactions in, 218-219
^{99m}Tc-DMSA in, 197-198
^{99m}Tc-glucaptate in, 197
o-[¹³¹I]iodohippurate in, 12
kinetics and, 26, 29-30
normal, 29
pathologic mechanisms altering, 258-260
- patient preparation for, 415-416
selection of radiopharmaceutical for, 77-78
^{99m}Tc-DMSA in, 10-11
^{99m}Tc-glucaptate versus, 79-80
^{99m}Tc-glucaptate in, 5
- Renal transplant evaluation, drug-radiopharmaceutical interactions affecting, [⁶⁷Ga]gallium citrate in, 215-216
- Renografin, 60, 171
- RES (see Reticuloendothelial system)
- Research, 106-108, 108r
designs for, 106-107
- Reserpine
[⁶⁷Ga]gallium citrate interactions with, 212-213
mIBG interactions with, 206-207
- Restraint, pediatric patient, 412
- Reticuloendothelial system (RES)
heparin effects on, 172
hepatobiliary imaging versus imaging of, 77
imaging agents for, 171-175
- Rifampin, [⁶⁷Ga]gallium citrate interactions with, 214-215
- Right to know, patient's, 404-405
- Risks (see Radiation hazards)
- RMS (see Radiolabeled metabolic substrates)
- ROC curve (see Receiver operating characteristic curve)
- Rotating slant hole tomography
limited-angle, 159-160
myocardial, 157, 158
- RPIC (see Radiopharmaceutical information center)
- S value, calculation of, 56-57
- ³⁵S-labeled sulfur colloid, biodistribution of, 47
- Salicylates, iodide interactions with, 204, 204r
- Saline, bacteriostatic, ^{99m}Tc-labeled radiopharmaceuticals and, 281
- Salivary glands
free pertechnetate in, 268, 269
increased radiotracer uptake in, 254
therapeutic irradiation of, radiotracer distribution affected by, 225
- SAR (see Structure-activity relationship)
- Sarcoma, animal models of, 346r
- Sarcoplasmic reticulum, cyclic adenosine monophosphate and, 181
- Schilling test, 280
drug-radiopharmaceutical interactions affecting, radio-cyanocobalamin in, 209-210
dual-isotope (Dicopac), 282-283
encapsulated doses and, 282
- Scientific method, process of, 106
- Scrotal imaging, 256, 260
- SDR (see Structure-distribution relationship)
- [⁷⁵Se]selenomethionine
normal biodistribution of, 15
pancreas imaging with, patient preparation for, 414
parathyroid imaging with, patient preparation for, 415
- Sedation, pediatric patient, 412
- Selection of radiopharmaceutical, 75-82
- Semen, drug effects on, 102-103, 103r
- Sensitivity, test for, defined, 134-135, 135r, 137r

- Sensitivity analysis, 142–143, 143
- Septal penetration, collimator selection and, 294, 294–295
- Septic meningitis, animal models of, 336, 338r
- Shock, animal models of, 335–336, 337r
- “Shock lung,” 173
- Sialadenitis, radiation, 225
- Sincalide (Kinevac)
- dose of, 127
 - hepatobiliary imaging with, 126–127, 417
- Single photon emission computed tomography (SPECT), 159
- problems with, 298–300, 299r
- Skeletal imaging (see also Bone)
- anterior, ^{99m}Tc-HDP, 9
 - drug-radiopharmaceutical interactions affecting, ^{99m}Tc-labeled phosphates and phosphonates in, 193–196
- Skeletal metastases, sodium [³²P]phosphate for pain from, 85, 86
- Skeletal system, pathophysiology of, animal models of, 334, 335r
- Smith orthogonal hole (SOH) phantom, 292
- Society of Nuclear Medicine, adverse reaction reporting and, 304
- Sodium ascorbate, effects on ^{99m}Tc-labeled radiopharmaceuticals, 81
- Sodium bicarbonate
- cardiac radiotracer effects of, 183
 - ^{99m}Tc-DMSA interactions with, 197–198
- Sodium [⁵¹Cr]chromate, metabolism of, 45–46
- Sodium diatrizoate, ^{99m}Tc-labeled phosphate and phosphonate interactions with, 195
- Sodium [¹²³I]iodide, normal biodistribution of, 11–12
- Sodium [¹³¹I]iodide
- description of, 87
 - dose of, 88
 - breastfeeding newborn, 63, 63r
 - fetal, 64, 64r, 65, 66–67, 68–69
 - drug interactions with, 204–205
 - encapsulation of, problems caused by, 282
 - indications for, 88
 - lactation and, 60r, 61
 - mechanism of action of, 87–88
 - metabolism of, 48–49
 - monitoring parameters of, 88
 - normal biodistribution of, 11–12
 - nuclear properties of, 76r
 - pharmacodynamics of, 88
 - pregnancy and, 64, 64r
 - toxicity of, 88
 - uptake of, 24-hour, probability of, 134r
 - volatility of, formulation problems related to, 283
- Sodium nitroprusside, iodide interactions with, 204, 204r
- Sodium [³²P]phosphate
- description of, 84
 - dose of, 85
 - indications for, 85
 - mechanism of action of, 84–85
 - monitoring parameters for, 86
 - pharmacodynamics of, 85–86
 - toxicity of, 85
- Software, 150
- SOH phantom (see Smith orthogonal hole phantom)
- Solubility
- formulation problems related to, 281
 - relative, for lipid or blood phases, 33
- Source material, 53
- Special nuclear material, 53
- Specialty Board Certification, licensing and, 324
- Specific activity, formulation problems related to, 280–281
- Specificity, test, 135
- SPECT (see Single photon emission computed tomography)
- Spectral overlap, 297
- Sperm, drug effects on, 102–103, 103r
- Spirolactone, [¹³¹I]iodomethylnorcholesterol interactions with, 205–206
- Spleen
- clinical variations in, radiopharmaceutical biodistribution and, 234–236, 235
 - interventional studies of, 127, 129
 - therapeutic irradiation of, radiotracer distribution affected by, 226
- Spleen imaging
- drug-radiopharmaceutical interactions affecting, ^{99m}Tc-labeled colloids in, 190–191
 - ^{99m}Tc-labeled red blood cells in, 11
- Splenic sequestration, ⁵¹Cr-labeled red blood cell studies of, 91
- Squamous cell carcinoma, animal models of, 346r
- Stannous ion
- drugs containing, ^{99m}Tc-pertechnetate interactions with, 199
 - formulation problems caused by, 274
- State radiological health departments, 53–54, 322, 322r–323r
- Steroids (see also Corticosteroids), iodide interactions with, 204, 204r
- Stomach (see also Gastric emptying studies)
- free pertechnetate in, 268, 269
 - intrathoracic, 252, 253
- Stress testing, 119, 154, 156–157, 156r, 416, 416r
- Stroke, 248
- animal models of, 336
- Structure-activity relationship (SAR), 33
- radiotracers and, 166
- Structure-distribution relationship (SDR), 33–34
- quantitative examples of, 38–41, 39–41
- Subdural hematoma, animal models of, 336, 338r
- Subjective probabilities, 133
- Substrate-nonspecific agents, 37–38, 35r, 38
- Substrate-specific agents, 34–37, 34, 35r
- Sulfipyrazone, [⁶⁷Ga]gallium citrate interactions with, 214–215
- Sulfonamides
- [⁶⁷Ga]gallium citrate interactions with, 214–215
 - ^{99m}Tc-pertechnetate interactions with, 199
- Sulfur colloid (see ^{99m}Tc-labeled colloids, sulfur)
- Surgery
- delayed consequences of, radiotracer biodistribution and, 227–228
 - nuclear medicine monitoring of, 104r
 - open, radiotracer biodistribution affected by, 226
 - Sympathomimetics, mIBG interactions with, 206–207
- T₃ (see Triiodothyronine)
- T₄ radioimmunoassay, probabilities of, 134, 134r
- Target uptake rate, selection of radiopharmaceutical and, 79
- ^{99m}Tc (see Carrier ^{99m}Tc)
- ^{99m}Tc
- nuclear properties of, 76, 76r
 - particulate impurities in, 268, 270
- ^{99m}Tc chelates
- biodistribution and structure of, 37–38, 38
 - incubation of, 277
- ^{99m}Tc-*N,N'*-bis(mercaptoacetyl)-2,3-diaminopropanoate, structure of, 37, 38
- ^{99m}Tc-diethylenetriaminepentaacetic acid (DTPA)
- brain imaging with, patient preparation for, 413–414
 - diuretic renogram with, 120, 121r
 - furosemide and, renal imaging with, 120, 121r
 - metabolism of, 48
 - normal biodistribution of, 4–5
 - pediatric use, 57
 - radioaerosol, 78
- ^{99m}Tc-diisopropyl-substituted iminodiacetic acid (DISIDA)
- hepatobiliary imaging with
 - abnormal, 28
 - normal, 27
 - normal biodistribution of, 8–10, 10
- ^{99m}Tc-dimercaptosuccinic acid (DMSA)
- drug interactions with, 197–198
 - incubation time and, 277
 - normal biodistribution of, 10–11
 - pediatric use, 57
 - pH, effect on biodistribution, 275
 - ^{99m}Tc-glucate versus, renal imaging and, 79–80
- ^{99m}Tc-diphosphonate, aluminum ion affecting formulation of, 274
- ^{99m}Tc-disofenin (see ^{99m}Tc-diisopropyliminodiacetic acid)
- ^{99m}Tc-glucate (glucoheptonate)
- adverse reactions to, 315r
 - brain imaging with, patient preparation for, 413–414
 - drug interactions with, 197
 - normal biodistribution of, 5
 - pediatric use, 57
- ^{99m}Tc-DMSA versus, renal imaging and, 79–80
- ^{99m}Tc-hydroxyethylidene diphosphonate (HEDP)
- metabolism of, 47–48
 - normal biodistribution of, 7–8
 - pH effect on biodistribution, 274–275
- ^{99m}Tc-hydroxymethylene diphosphonate (HDP)
- comparison with MDP, 80
 - metabolism of, 47–48
 - normal biodistribution of, 7–8, 9
- ^{99m}Tc-*p*-isopropyliminodiacetic acid (PIPIDA), normal biodistribution of, 8, 9
- ^{99m}Tc-labeled agents (see also specific agent)
- bone imaging with, 80, 102
 - fetal dose of, 65, 66–67
 - formulation of
 - clinical manifestations of problems with, 268–270, 269–270
 - commercial source and, 278–279
 - ligand concentration affecting, 276
 - mixing order in, 275–276
 - particulate size and number in, 277–278
 - oxidation and, 279–280
 - pH and, 274–275
 - radiolytic decomposition and, 279–280
 - specific activity and, 280–281
 - stannous ion affecting, 274
 - lactation and, 59–60, 60r
 - metabolism of, 46–48
 - preservatives and, 281
 - solubility of, 281
 - ^{99m}Tc-labeled albumin
 - macroaggregated
 - drug interactions with, 198–199
 - metabolism of, 47
 - normal biodistribution of, 5, 6
 - pediatric use, 57
 - metabolism of, 47
 - microspheres
 - adverse reactions to, 315r, 316
 - drug interactions with, 198–199
 - pediatric use, 57
 - normal biodistribution of, 11
 - ^{99m}Tc-labeled colloids
 - antimony trisulfide, 67
 - drug interactions with, 190–191
 - impurities in, 268, 269
 - normal biodistribution of, 5–7, 7
 - pulmonary uptake of, factors associated with, 392r
 - sulfur
 - adverse reactions to, 314r, 315–316
 - aluminum ion affecting formulation of, 274
 - efficacy of, 111
 - liver and spleen imaging with, 234–236, 235
 - metabolism of, 46–47
 - normal distribution of, 5–7, 7
 - pediatric use, 57
 - renal accumulation of, 174
 - ^{99m}Tc-labeled iminodiacetic acid (IDA) derivatives
 - drug interactions with, 191–193
 - hepatobiliary imaging with, patient preparation for, 417
 - metabolism of, 48
 - normal biodistribution of, 8–10, 10
 - phenobarbital and, hepatobiliary imaging with, 125–126
 - quantitative structure-distribution relationships of, 38–40, 39
 - radiopharmacokinetics of, 24–25, 24, 24r
 - selection of, hepatobiliary imaging and, 80, 80r
 - ^{99m}Tc-labeled kits, 81–82
 - stannous ion and, 274
 - ^{99m}Tc-labeled phosphate and phosphonate (see also specific agent)
 - adverse reactions to, 316–317
 - bone studies with, patient preparation for, 413
 - drug interactions with, 193–197
 - metabolism of, 47

- ^{99m}Tc-labeled phosphate and phosphonate—*continued*
 normal biodistribution of, 7–8, 9
 pediatric use, 57
- ^{99m}Tc-labeled red blood cells, 4
 anticoagulants affecting, 281–282
 clinical utility of, 91–92
 drug interactions with, 199–202
 efficacy of, 111
 normal biodistribution of, 11
 pediatric use, 57
 preparation of, 90–91, 92r
- ^{99m}Tc-methylene diphosphonate (MDP)
 adverse reactions to, 314r, 316
 comparison with HDP, 80
 hydrolysis of, 278
 normal biodistribution of, 7–8
- ^{99m}Tc-penicillamine, 184
- ^{99m}Tc-pertechnetate
 aluminum ion affecting formulation of, 274
 brain imaging with, patient preparation for, 413
 dose to breastfeeding newborn, 62–63, 62r–63r
 drug interactions with, 169–171, 199
 Meckel's diverticulum imaging with
 patient preparation for, 415
 pentagastrin and, 124–125, 415
 metabolism of, 46
 normal biodistribution of, 3–4, 4
 variations of, 237–239, 239
 pediatric use, 57
 thyroid imaging with, 4
 patient preparation for, 412
 unusual pathologic variations, 249–250
- ^{99m}Tc-polyphosphate
 normal biodistribution of, 7–8
 structure of, 41, 41r
- ^{99m}Tc-pyrophosphate (PYP)
 bone imaging with, therapeutic irradiation effects on, 223
 metabolism of, 47–48
 normal biodistribution of, 7–8
- Temperature, ^{99m}Tc-labeled sulfur colloid formulation and, 276
- Teratogenicity, 64–69, 68r
- Test results, distribution, 135–136, 135–136
- Testicular imaging, pathologic mechanisms altering, 256, 260
- Thalassemia major, 260, 261
- Thallium, normal biodistribution of, 13
- Therapeutic applications, 84–88
- Therapeutic irradiation (*see* Radiation therapy)
- Thorium, 53
- Thorium dioxide, ^{99m}Tc-labeled colloid interactions with, 191
- Threshold values, optimal, 135–136, 137r
- Thrombus
 localization of, patient preparation for, 414–415
 venous
 animal models of, 339r
¹²⁵I-fibrinogen detection of, 13
¹¹¹In-labeled platelet detection of, 95–96
- Thyroid blockade, 413, 415
- Thyroid gland
 carcinoma of, sodium [¹³¹I]iodide for, 88
 clinical variations in, radiopharmaceutical biodistribution and, 237–239, 239–241
 cold nodule of, 249, 250, 251
 free pertechnetate in, 268, 269
 interventional studies involving, 115–116
 organification defects in, 116
 therapeutic irradiation of, radiotracer distribution affected by, 225
- Thyroid hormone manipulation, 115–116
- Thyroid imaging
 drug-radiopharmaceutical interactions affecting, 183–184
 sodium [¹²⁷I]iodide and sodium [¹³¹I]iodide, 204–205
^{99m}Tc-pertechnetate, 199
 pathologic mechanisms altering, 249–251, 250
 patient preparation for, 412
 selection of radiopharmaceutical for, 79
^{99m}Tc-pertechnetate in, 4, 4, 239
- Thyroid preparations, iodide interactions with, 204, 204r
- Thyroid uptake test, 102
 probabilities of, 134r
 sodium [¹³¹I]iodide, 115
- Thyroid-stimulating hormone (TSH), 116
 test, 116
- Thyroiditis, Hashimoto's, 116
- Thyrotoxicosis, 251
- Thyrotropin-releasing hormone (TRH), infusion test, 116
- Time compression, scintigraphic computer for, 159
- Tin complex, pertechnetate distribution and, 171
- [²⁰¹Tl]thallous chloride
 coronary artery disease and, 154, 156–157, 156, 158
 drug interactions with, 207–209
 field flood imaging, 292
 metabolism of, 45
 myocardial imaging with, 118–119, 118r
 patient preparation for, 416, 416r
 normal biodistribution of, 13
 nuclear properties of, 76, 76r
 potassium versus, 182
- Tomography (*see also* specific type), 158, 159–160
 annihilation radiation and, 160
- Total parenteral nutrition (TPN)
 gastric emptying radiotracer interactions with, 216
¹¹¹In-labeled leukocyte interactions with, 203
 radioxenon interactions with, 211
^{99m}Tc-labeled iminodiacetic acid derivative interactions with, 192
- TPN (*see* Total parenteral nutrition)
- Tranquillizers (*see also* specific agent)
 cell membrane effects of, 167, 178
- Transferrin, [⁶⁷Ga]gallium citrate and, 178
- Transfusion, radiotracer biodistribution and, 229
- Transplant rejection
 drug-radiopharmaceutical interactions affecting, 215–216
¹¹¹In-labeled leukocyte detection of, 95
- Trauma, iatrogenic, radiotracer biodistribution and, 226–229, 227–229
- TRH (*see* Thyrotropin-releasing hormone)
- Tritiothyronine (T₃), 115–116
 cardiac effects of, 116
 radioimmunoassay, probabilities of, 134r
 resin test, probabilities of, 134r
 suppression test, 115–116
- Trimethoprim-sulfamethoxazole, ^{99m}Tc-gluceptate interactions with, 197
- Tropolone, 94
- TSH (*see* Thyroid-stimulating hormone)
- Tubular necrosis, animal models of, 342r
- Tumor (*see also* Cancer)
 animal models of, 346–347, 346r
 brain, 248, 249
 central nervous system, animal models of, 336, 338r
 localization
 patient preparation for, 414
 drug-radiopharmaceutical interactions affecting, [⁶⁷Ga]gallium citrate in, 211–215
- Tyrosine, iodination of, 12
- ²³⁵U, 53
²³⁸U, 53
- Ulcer, duodenal or gastric, animal models of, 340r
- United Kingdom
 adverse reaction reporting in, 307
 adverse reaction statistics on, 311–312, 312r
- United States
 adverse reaction reporting in, 304, 305–306, 310
 adverse reaction statistics on, 311–312, 311r
- Uranium, 53
- Valvular damage, animal models of, 337r
- Vascular imaging, pathologic mechanisms altering, 252, 252
- Vasoconstriction, vasopressin for, 124
- Vasodilation, dipyridamole, 117–119
- Vasopressin
 gastrointestinal bleeding studies and, 124
 [²⁰¹Tl]thallous chloride interactions with, 208–209
- Vasovagal reactions, 313
- Vena cava obstruction, 252, 254
- Venous thrombus
 animal models of, 339r
¹²⁵I-fibrinogen detection of, 13
¹¹¹In-labeled platelet detection of, 95–96
- patient preparation for localization of, 414–415
- Ventilation imaging, 78, 78r
- Ventilation systems, radiogases and, 329
- Ventricular reflux, 248–249
- Ventriculography (*see also* Blood pool imaging)
 drug-radiopharmaceutical interactions affecting, ^{99m}Tc-labeled red blood cells in, 199–202
 gated, 151–154, 151–153, 155
- Vinblastine, phagocytosis and, 174
- Vincristine
 brain-imaging radiopharmaceutical interactions with, 216–217
 [⁶⁷Ga]gallium chloride interactions with, 213
^{99m}Tc-labeled phosphate and phosphonate interactions with, 194
- Vitamin B₁₂, radiocyanocobalamin interactions with, 209–210
- Vitamin D₃, radiotracer uptake and, 176
- Vitamins, iodide interactions with, 240, 204r
- Volatility, iodine, formulation problems related to, 283
- Warfarin resistance, animal models of, 345, 345r
 waste (*see* Low-level radioactive waste)
- Whole-body irradiation [⁶⁷Ga]gallium citrate biodistribution and, 225–226
- ¹³³Xe
 in children, 57
 drug interactions with, 211
 field flood imaging with, 292
 metabolism of, 45
 normal biodistribution of, 15–16, 16
 problems in imaging after ^{99m}Tc perfusion studies, 296–297
 regulatory control of, 329
- ⁹⁰Y, formulation errors involving, absorbed dose and, 70
- ¹⁶⁹Yb-diethylenetriaminepentaacetic acid (DTPA), drug interactions with, 202
- Zona glomerulosa, aldosterone production in, 117
- Zymosan, phagocytosis and, 174