



(12) **United States Patent**
Davies

(10) **Patent No.:** **US 6,993,049 B2**
(45) **Date of Patent:** ***Jan. 31, 2006**

(54) **COMMUNICATION SYSTEM**

(75) **Inventor:** **Robert J. Davies**, Horley (GB)

(73) **Assignee:** **Koninklijke Philips Electronics N.V.**,
Eindhoven (NL)

(*) **Notice:** This patent issued on a continued prosecution application filed under 37 CFR 1.53(d), and is subject to the twenty year patent term provisions of 35 U.S.C. 154 (a)(2).

Subject to any disclaimer, the term of this patent is extended or adjusted under 35 U.S.C. 154(b) by 635 days.

This patent is subject to a terminal disclaimer.

(21) **Appl. No.:** **09/876,514**

(22) **Filed:** **Jun. 7, 2001**

(65) **Prior Publication Data**

US 2002/0028657 A1 Mar. 7, 2002

(30) **Foreign Application Priority Data**

Jun. 26, 2000 (GB) 0015454
Aug. 15, 2000 (GB) 0020076

(51) **Int. Cl.**

H04J 3/12 (2006.01)
H04J 3/16 (2006.01)
H04L 12/403 (2006.01)

(52) **U.S. Cl.** **370/528; 370/346; 370/449; 370/465**

(58) **Field of Classification Search** **370/311, 370/312, 328-330, 336, 337, 346, 347, 350, 370/390, 465, 470, 473, 476, 491, 528, 449**
See application file for complete search history.

(56) **References Cited**

U.S. PATENT DOCUMENTS

4,766,434 A * 8/1988 Matai et al. 340/7.55
6,574,266 B1 * 6/2003 Haartsen 375/133
6,664,891 B2 * 12/2003 Davies et al. 340/505

* cited by examiner

Primary Examiner—Chi Pham
Assistant Examiner—Ronald Abelson

(57) **ABSTRACT**

A communications system comprises a primary station (100) and at least one secondary station (101). The primary station (100) is arranged to broadcast a series of inquiry messages, each in the form of a plurality of predetermined data fields arranged according to a first communications protocol such as Bluetooth. In addition the primary station (100) adds to some or all of the inquiry messages an additional data field for polling one or more secondary stations, which can respond to the poll if they have data for transmission. This system provides secondary stations (101) with a rapid response time without the need for a permanently active communication link.

12 Claims, 3 Drawing Sheets

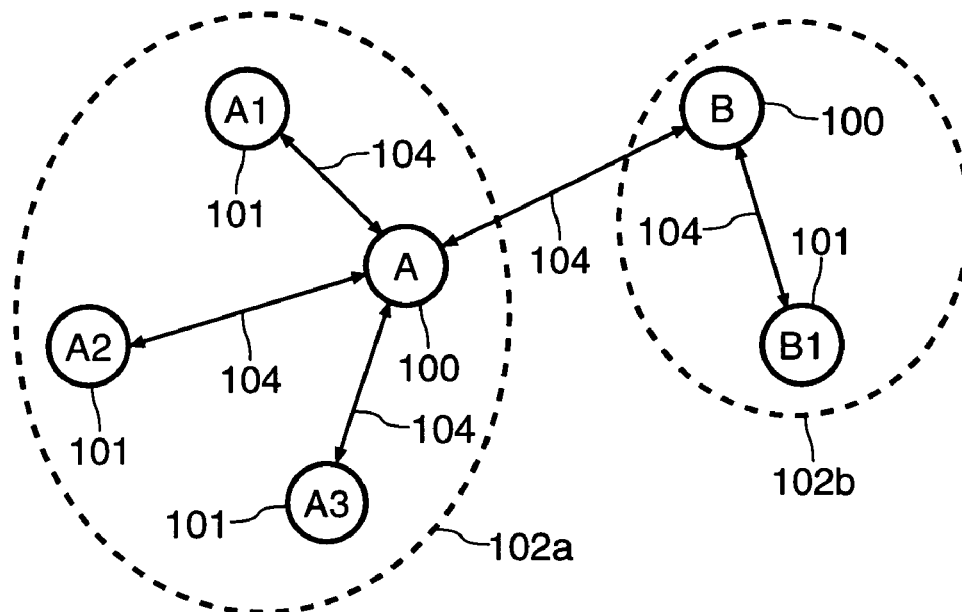

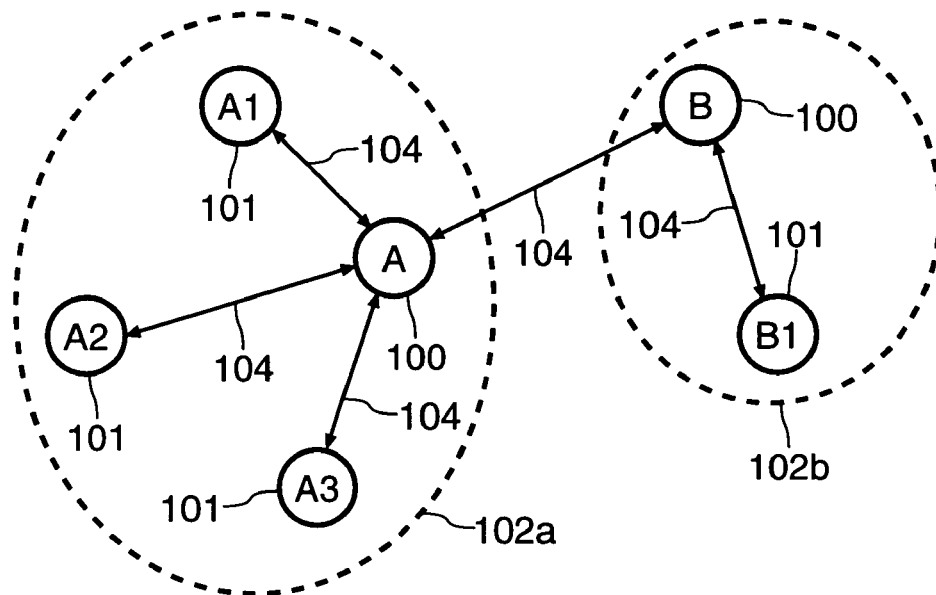

FIG. 1

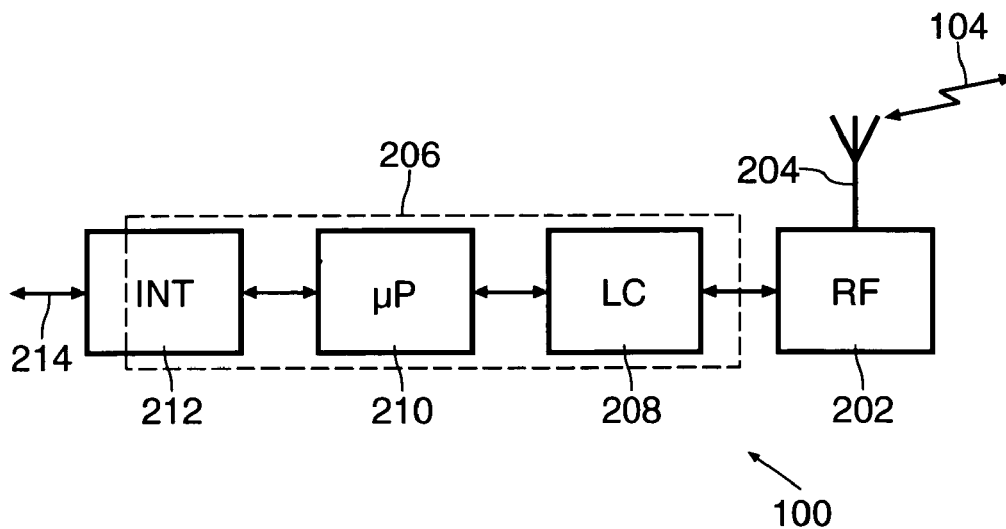

FIG. 2

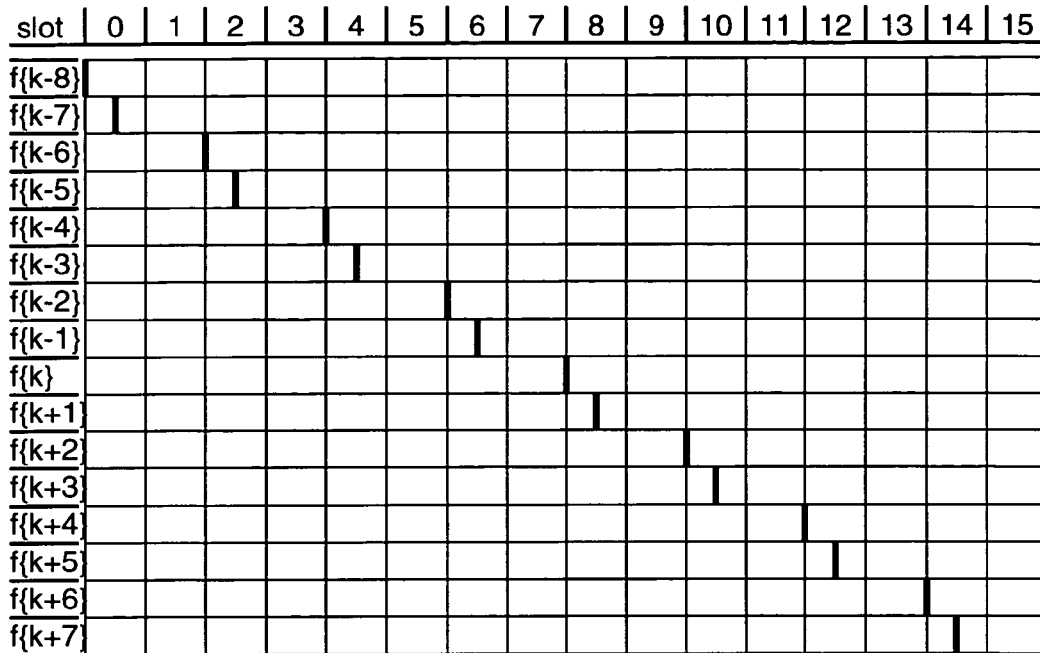

FIG. 3

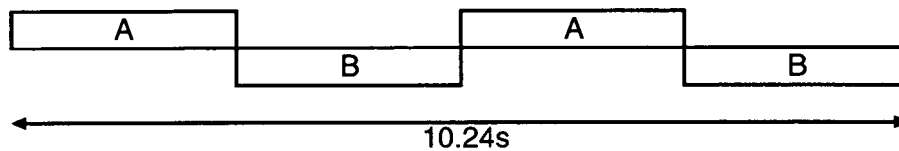

FIG. 4

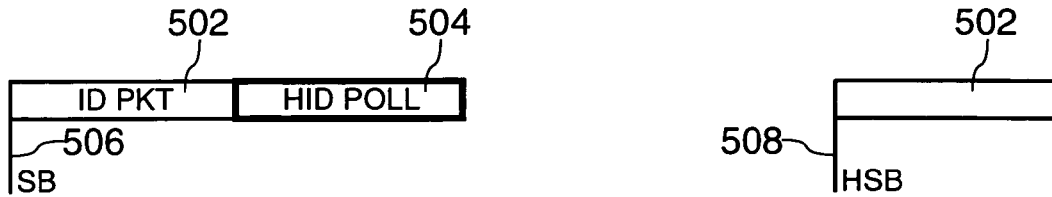

FIG. 5

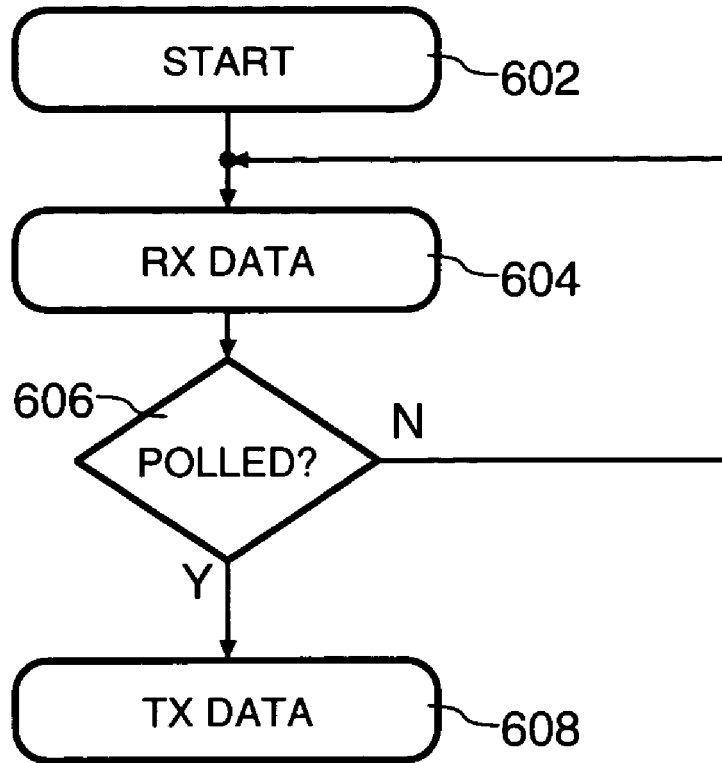

FIG. 6

COMMUNICATION SYSTEM

The present invention relates to a communication system and further relates to primary and secondary stations for use in such a system and to a method of operating such a system. Although the present invention is described with particular reference to a Bluetooth system, it is applicable to a range of other communication systems.

In recent years there has been increasing interest in enabling devices to interact via wireless communication links, thereby avoiding the need for extensive cabling. An example of a communication system which may be used for such wireless links is a Bluetooth network, operating according to the specification defined by the Bluetooth Special Interest Group. Such a network is intended to provide low-cost, short range radio links between mobile PCs, mobile phones and other devices, whether portable or not.

Communication in a Bluetooth network takes place in the unlicensed ISM band at around 2.45 GHz. Stations form ad-hoc networks which are known as piconets, each comprising a master station and up to seven slave stations. All stations are identical and capable of acting as master or slave as required. A station can take part in more than one piconet, thereby linking piconets and enabling communication over an extended range.

One application for which use of Bluetooth is proposed is the connection of controller devices to host systems. A controller device, also known as a Human/machine Interface Device (HID), is an input device such as a keyboard, mouse, games controller, graphics pad or the like. Such HIDs do not typically require a link having high data throughput, but do require a very responsive link.

A Bluetooth system is more than capable of supporting the throughput requirements of HIDs. However, the degree of responsiveness required can be more difficult to achieve. An active Bluetooth link can offer a reasonably responsive service, but this requires both setting up of the link and its maintenance even during periods of inactivity.

Two types of communication link supported in a Bluetooth network are Asynchronous ConnectionLess (ACL) links and Synchronous Connection Oriented (SCO) links. ACL links allow slaves to enter a 'park' mode and cease active communications, which also allows a number of other HIDs to maintain links with the master station without violating the Bluetooth rule that no more than seven slaves can be active at any one time. A slave has to be polled before it can submit a request to leave park mode and become active. SCO links require continuous operation by a slave, but there are only a limited number of SCO channels available.

Setting up a link requires a HID to join, as a slave, the piconet including the host system (which will typically act as piconet master, i.e. a base station). Joining the piconet requires two sets of procedures, namely 'inquiry' and 'page'. Inquiry allows a would-be slave to find a base station and issue a request to join the piconet. Page allows a base station to invite slaves of its choice to join the net. Analysis of these procedures indicates that the time taken to join a piconet and then to be in a position to transfer user input to the master could be several tens of seconds.

It is possible for this procedure to be carried out once and for all when the host system is turned on. However, HIDs will normally be battery operated and it is therefore not acceptable for them to have to remain permanently switched

have to be regularly waking up to look for Bluetooth inquiry bursts, thereby consuming power, or it will need to be manually woken up by the user.

It is therefore more likely that a HID will remain inactive until it is woken up, either by being explicitly switched on or by a user attempting some form of input. Hence, the host system's Bluetooth master will need to run inquiry cycles periodically, which has two implications. The first is that because the inquiry phase is periodic rather than continuous, initial access time could be several tens of seconds. This could mean that it could take half a minute or more from the time a user moves a mouse to a cursor moving on a screen. Secondly, the fact that an inquiry cycle takes place at all means that ACL links will be suspended during this cycle, for up to 10.24 seconds at a time. Although SCO links could be used, a HID using such a link could not cease transmissions during inactive periods.

It is therefore an object of the invention to address the problem of providing a responsive link between a HID and a host system which allows the HID to go to sleep during periods of inactivity.

According to a first aspect of the present invention there is provided a communications system comprising a primary station and at least one secondary station, wherein the primary station has means for broadcasting a series of inquiry messages, each in the form of a plurality of predetermined data fields arranged according to a first communications protocol, and means for adding to an inquiry message prior to transmission an additional data field for polling at least one secondary station, and wherein the or each polled secondary station has means for determining when an additional data field has been added to the plurality of data fields, for determining whether it has been polled from the additional data field and for responding to a poll when it has data for transmission to the primary station.

According to a second aspect of the present invention there is provided a primary station for use in a communications system comprising at least one secondary station, wherein means are provided for broadcasting a series of inquiry messages, each in the form of a plurality of predetermined data fields arranged according to a first communications protocol, and for adding to each inquiry message prior to transmission an additional data field for polling at least one secondary station.

According to a third aspect of the present invention there is provided a secondary station for use in a communications system comprising a primary station, wherein means are provided for receiving an inquiry message broadcast by the primary station, the message being in the form of a plurality of predetermined data fields arranged according to a first communications protocol and having added to it an additional data field for polling at least one secondary station, and wherein means are provided for determining when an additional data field has been added to the plurality of data fields, for determining whether it has been polled from the additional data field and for responding to a poll when it has data for transmission to the primary station.

According to a fourth aspect of the present invention there is provided a method of operating a communication system comprising a primary station and at least one secondary station, the method comprising the primary station broadcasting a series of inquiry messages, each in the form of a plurality of predetermined data fields arranged according to a first communications protocol, and adding to an inquiry message prior to transmission an additional data field for

Explore Litigation Insights

Docket Alarm provides insights to develop a more informed litigation strategy and the peace of mind of knowing you're on top of things.

Real-Time Litigation Alerts



Keep your litigation team up-to-date with **real-time alerts** and advanced team management tools built for the enterprise, all while greatly reducing PACER spend.

Our comprehensive service means we can handle Federal, State, and Administrative courts across the country.

Advanced Docket Research



With over 230 million records, Docket Alarm's cloud-native docket research platform finds what other services can't. Coverage includes Federal, State, plus PTAB, TTAB, ITC and NLRB decisions, all in one place.

Identify arguments that have been successful in the past with full text, pinpoint searching. Link to case law cited within any court document via Fastcase.

Analytics At Your Fingertips



Learn what happened the last time a particular judge, opposing counsel or company faced cases similar to yours.

Advanced out-of-the-box PTAB and TTAB analytics are always at your fingertips.

API

Docket Alarm offers a powerful API (application programming interface) to developers that want to integrate case filings into their apps.

LAW FIRMS

Build custom dashboards for your attorneys and clients with live data direct from the court.

Automate many repetitive legal tasks like conflict checks, document management, and marketing.

FINANCIAL INSTITUTIONS

Litigation and bankruptcy checks for companies and debtors.

E-DISCOVERY AND LEGAL VENDORS

Sync your system to PACER to automate legal marketing.