

16978 U.S. PTO  
10/100362  
03/18/02

APR 01 2003

U.S. UTILITY Patent Application

PATENT NUMBER and  
ISSUE DATE  
**6540815**

6540815

APPL. NUM 10100262	FILING DATE 03/18/2002	CLASS 562 <sup>95</sup>	SUBCLASS	GAU 1754	EXAMINER <i>Lawrence</i>
**APPLICANTS: Hiltzik Laurence; Jagielo Jacek; Tolles Edward; Williams Roger;					
Certificate AUG 26 2003 of Correction					
CONTINUING DATA VERIFIED: THIS APP. CLAIMS BENEFIT OF 60/335,897 11/21/2001 <i>JK</i>					
FOREIGN APPLICATIONS VERIFIED: <i>JK none</i>					
DO NOT PUBLISH <input type="checkbox"/>			RESCIND <input type="checkbox"/>		
Design priority claimed <input type="checkbox"/> yes <input checked="" type="checkbox"/> no			ATTORNEY DOCKET NO.		
35 USC 119 conditions met <input type="checkbox"/> yes <input checked="" type="checkbox"/> no			CHR 2001-79		
Certified and Acknowledged Examiners's initials. <i>JK</i>			TITLE: Method for reducing emissions from evaporative emissions control systems		
<small>U.S. DEPT. OF COMM/PAT. &amp; TM-PTO-436L (Rev. 12-94)</small>					

*12/03/02 Formal Drawings (3 sheets) set @ 103/18/02*

NOTICE OF ALLOWANCE MAILED		Frank M. Lawrence Assistant Examiner 9-24-02	CLAIMS ALLOWED	
<i>11-27-03</i>			Total Claims <b>30</b>	Print Claim for O.G. <b>1</b>
ISSUE FEE		David A. Simmons Supervisory Patent Examiner Technology Center 1700 <i>David A. Simmons</i> Primary Examiner	DRAWING	
Amount Due \$20.00	Date Paid <i>2-3-03</i> <del>1-19-02</del>		Sheets Drwg. <b>3</b>	Figs. Drwg. <b>3</b>
<input type="checkbox"/> TERMINAL DISCLAIMER		PREPARED FOR ISSUE	Application Examiner <i>John W. [Signature]</i> 10-09-02	
WARNING: The information disclosed herein may be restricted. Unauthorized disclosure may be prohibited by the United States Code Title 35, Sections 122, 181 and 368, Possession outside the U.S. Patent & Trademark Office is restricted to authorized employees and contractors only.				

**ISSUE FEE**

FILED WITH:  DISK (CRF)  CD-ROM  
(Attached in pocket on right inside flap)

NOV 02



10100362



INITIALS 4/4/02

### CONTENTS

1700

	Application papers.	Date Received (incl. C. of M.) or Date Mailed		Date Received (incl. C. of M.) or Date Mailed
1.			31.	
2.	<u>WRRE Necmiss</u>	<u>04-24-02</u>	32.	
3.	<u>Decl Fee</u>	<u>05/09/02</u>	33.	
4.	<u>Proc Amended A</u>	<u>05/09/02</u>	34.	
5.	<u>Petition</u>	<u>05/09/02</u>	35.	
6.	<u>Pet. Granted</u>	<u>9-20-02</u>	36.	
7.	<u>Notice of Allowance</u>	<u>10/8/02</u>	37.	
8.	<u>ODS</u>	<u>12-10-02</u>	38.	
9.	<u>RCE</u>	<u>12-11-02</u>	39.	
10.	<u>Pet WD Issue</u>	<u>12-11-02</u>	40.	
11.	<u>Pet Granted</u>	<u>12-11-02</u>	41.	
12.	<u>Notice of Allowance</u>	<u>1/27/03</u>	42.	
13.	<u>Reg Coll</u>	<u>5/6/03</u>	43.	
14.	<u>Directors Report</u>	<u>7/16/03</u>	44.	
15.	<u>Approval report</u>	<u>7/31/03</u>	45.	
16.			46.	
17.			47.	
18.			48.	
			49.	
			50.	
			51.	
			52.	
			53.	
			54.	
			55.	
			56.	
			57.	
			58.	
			59.	
30.			60.	

10100362  
 1439F RET 22638721 - 000001 RT ID: VD  
 M -A2-DOCK-DATAENTRY N/A  
 M -A2-01-1-02-0011-3-01-08  
 SKP:RF048906099 - 00006  
 6540815  
 CUST:RF048906099  
 NEW  
 STX:0360 1:00pm EDT  
 FOR: BY/PAS  
 KATHY KANNORSKY  
 R

## SEARCH

Class	Sub.	Date	Exmr.
95	90 146 148 900-903	9-23-02	
96	132 133 <del>13</del> 147		
123	518 519		
502	416		FL
search	updated	1-14-03	FL

## SEARCH NOTES

(List databases searched. Attach search strategy inside.)

	Date	Exmr.
Inventor search BRS, PG Pubes	9-23-02 	FL

### INTERFERENCE SEARCHED

Class	Sub.	Date	Exmr.
95	146 900	9-24-02	
123	519		FL

ISSUE SLIP STAPLE AREA (for additional cross-references)

ISSUING CLASSIFICATION			
ORIGINAL		CROSS REFERENCE(S)	
CLASS	SUBCLASS	CLASS	SUBCLASS (ONE SUBCLASS PER BLOCK)
95	146	95	900
INTERNATIONAL CLASSIFICATION		123	519
F02M	33102		
B01D	53104		
	1		
	1		
	1		

^ Continued on Issue Slip Inside File Jacket

INDEX OF CLAIMS

✓ ..... Rejected - (Through numeral) ... Canceled N ..... Non-elected A ..... Appeal  
 = ..... Allowed + ..... Restricted I ..... Interference O ..... Objected

Claim	Date	Claim	Date	Claim	Date
Final Original		Final Original		Final Original	
1	8/29/9	51		101	
2		52		102	
3		53		103	
4		54		104	
5		55		105	
6		56		106	
7		57		107	
8		58		108	
9		59		109	
10		60		110	
11		61		111	
12		62		112	
13		63		113	
14		64		114	
15		65		115	
16		66		116	
17		67		117	
18		68		118	
19		69		119	
20		70		120	
21		71		121	
22		72		122	
23		73		123	
24		74		124	
25		75		125	
26		76		126	
27		77		127	
28		78		128	
29		79		129	
30		80		130	
31		81		131	
32		82		132	
33		83		133	
34		84		134	
35		85		135	
36		86		136	
37		87		137	
38		88		138	
39		89		139	
40		90		140	
41		91		141	
42		92		142	
43		93		143	
44		94		144	
45		95		145	
46		96		146	
47		97		147	
48		98		148	
49		99		149	
50		100		150	

If more than 150 claims or 9 actions staple additional sheet here

829 04/24

851  
06/06/8



### CLASSIFICATION NOTES

Examiner/ Classifier	Class	Date	Initials

POSITION	NAME	ID NO.	DATE
FEE DETERMINATION	EH		03-21-02
FILE ASSEMBLY			
QUALITY CHECK			
SCANNING	Kona	CP	3/25/02
CLASSIFIER	(B2)	10	3/28/02
FORMALITY REVIEW	Faruq	43	4/4/02
RESPONSE	Syed	720	04-24-02
		5039	06/06/02

PATENT APPLICATION SERIAL NO. 10/100362

U.S. DEPARTMENT OF COMMERCE  
PATENT AND TRADEMARK OFFICE  
FEE RECORD SHEET

03/22/2002 EHAILE1 00000014 10100362

01 FC:101	740.00	OP
02 FC:103	180.00	OP

PTO-1556  
(5/87)

\*U.S. Government Printing Office: 2001 — 481-697/59173



UNITED STATES PATENT AND TRADEMARK OFFICE

COMMISSIONER FOR PATENTS  
UNITED STATES PATENT AND TRADEMARK OFFICE  
WASHINGTON, D.C. 20231  
www.uspto.gov

\*BIBDATASHEET\*

Bib Data Sheet

CONFIRMATION NO. 3899

SERIAL NUMBER 10/100,362	FILING DATE 03/18/2002 RULE	CLASS 502	GROUP ART UNIT 1724	ATTORNEY DOCKET NO. CHR 2001-79
-----------------------------	-----------------------------------	--------------	------------------------	---------------------------------------

APPLICANTS

Laurence H. Hiltzik, Charleston, SC;  
Jacek Z. Jagiello, Charleston, SC;  
Edward D. Tolles, Charleston, SC; Roger S. Williams, Lexington, SC;

\*\* CONTINUING DATA \*\*\*\*\*  
THIS APPLN CLAIMS BENEFIT OF 60/335,897 11/21/2001 *AK*

\*\* FOREIGN APPLICATIONS \*\*\*\*\*

*AK none*

IF REQUIRED, FOREIGN FILING LICENSE GRANTED  
\*\* 04/24/2002

Foreign Priority claimed 35 USC 119 (a-d) conditions met and Acknowledged	<input type="checkbox"/> yes <input checked="" type="checkbox"/> no <input type="checkbox"/> yes <input checked="" type="checkbox"/> no <input type="checkbox"/> Met after Allowance	STATE OR COUNTRY SC	SHEETS DRAWING 3	TOTAL CLAIMS 30	INDEPENDENT CLAIMS 2
Examiner's Signature <i>Mr. Lee</i> Initials					

ADDRESS  
Westvaco Corporation  
5255 Virginia Avenue  
P.O. Box 118005  
Charleston, SC  
29423-8005

TITLE  
Method for reducing emissions from evaporative emissions control systems

FEES: Authority has been given in Paper  
No. \_\_\_\_\_ to charge/credit DEPOSIT ACCOUNT  
No. \_\_\_\_\_ for following:

- All Fees
- 1.16 Fees ( Filing )
- 1.17 Fees ( Processing Ext. of time )
- 1.18 Fees ( Issue )
- Other \_\_\_\_\_
- Credit

3-19-02

EXPRESS MAIL NO. EK902687082US



FORM PTO-1082

Case Docket No. CHR 2001-79

PATENT APPLICATION TRANSMITTAL LETTER

To: Box Patent Application  
Assistant Commissioner for Patents  
Washington, DC 20231

Transmitted herewith for filing under 35 USC 111 and 37 CFR 1.53 is the original (nonprovisional) patent application of

Inventor(s): Laurence H. Hiltzik, Jacek Z. Jagiello,  
Edward D. Tolles, and Roger S. Williams

Entitled: METHOD FOR REDUCING EMISSIONS FROM  
EVAPORATIVE EMISSIONS CONTROL SYSTEMS

Enclosed are:

XXX 18 pages of specification.

XXX 5 pages of claims.

XXX 3 sheets of drawings.

\_\_\_\_\_ formal

\_\_\_\_\_ 3 informal

XXX 1 page(s) Abstract.

\_\_\_\_\_ Executed declaration or oath of the inventors.

\_\_\_\_\_ An assignment of the invention to: Westvaco Corporation,  
Westvaco Corporate Center, 1 High Ridge Park, Stamford,  
Connecticut 06905, a corporation of the State of Delaware.

\_\_\_\_\_ A separate cover sheet for Assignment  
(Document) accompanying new patent  
application is also attached.

\_\_\_\_\_ A certified copy of a \_\_\_\_\_ application.

\_\_\_\_\_ Associate power of attorney.

\_\_\_\_\_ A verified statement to establish small entity status under  
37 CFR 1.9 and 1.27.

\_\_\_\_\_ Information disclosure statement.

\_\_\_\_\_ Preliminary amendment.

\_\_\_\_\_ Other: \_\_\_\_\_

CLAIMS AS FILED

	NUMBER FILED	NUMBER EXTRA	RATE	FEE
BASIC FEE			\$ 740.00	\$ 740.00
TOTAL CLAIMS	30 - 20 =	* 10	x 18.00	180.00
INDEPENDENT CLAIMS	2 - 3 =	* 0	x 84.00	0

\*NUMBER EXTRA MUST BE ZERO OR LARGER

TOTAL	\$ 920.00
ASSIGNMENT RECORDATION FEE	\$
TOTAL	\$ 920.00



Case Docket No. CHR 2001-79

If applicant has small entity status under 37 CFR 1.9 and 1.27, then divide total fee by 2, and enter amount here.

SMALL ENTITY TOTAL \$

XXX A check in the amount of \$ 920.00 is enclosed to cover the application filing fee.

     A check in the amount of \$            is enclosed to cover the Assignment recordation fee.

XXX The Commissioner is hereby authorized to charge or credit Deposit Account No. 23-1160 as described below. I have enclosed a duplicate copy of this sheet.

     Charge the amount of \$            as filing fee.

XXX Credit any overpayment.

XXX Charge any additional filing fees required under 37 CFR 1.16 and 1.17.

     Charge the issue fee set in 37 CFR 1.18 at the mailing of the Notice of Allowance, pursuant to 37 CFR 1.311(b).

March 18, 2002  
Date

  
Signature

Terry B. McDaniel, Regis. No. 28,444  
Westvaco Corporation  
5255 Virginia Avenue  
P. O. Box 118005  
Charleston, SC 29423-8005

Telephone: (843) 746-8490

EXPRESS MAIL NO. EK902687082US

Case Docket No. CHR 2001-79

CERTIFICATE UNDER 37 C.F.R. 1.10(a)

I hereby certify that this correspondence is being deposited with the United States Postal Service as Express Mail in an envelope addressed to the Assistant Commissioner for Patents, Washington, D. C. 20231, on March 18, 2002.

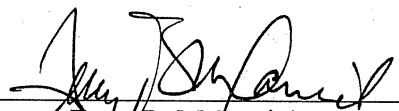

Terry B. McDaniel  
Attorney for the Applicants  
Registration No. 28,444

10100332 031503

AK  
1-24-02

Abstract

~~DISCLOSURE OF THE SPECIFICATION~~

Disclosed is a method for sharply reducing diurnal breathing loss emissions from automotive evaporative emissions control systems by providing multiple layers, or stages, of adsorbents. On the fuel source-side of an emissions control system canister, high working capacity carbons are preferred in a first canister (adsorb) region. In subsequent canister region(s) on the vent-side, the preferred adsorbent should exhibit a flat or flattened adsorption isotherm on a volumetric basis and relatively lower capacity for high concentration vapors as compared with the fuel source-side adsorbent. Multiple approaches are described for attaining the preferred properties for the vent-side canister region. One approach is to use a filler and/or voidages as a volumetric diluent for flattening an adsorption isotherm. Another approach is to employ an adsorbent with the desired adsorption isotherm properties and to process it into an appropriate shape or form without necessarily requiring any special provision for dilution. The improved combination of high working capacity carbons on the fuel source-side and preferred lower working capacity adsorbent on the vent-side provides substantially lower diurnal breathing emissions without a significant loss in working capacity or increase in flow restriction compared with known adsorbents used in canister configurations for automotive emissions control systems.

1010333-9490

IN THE UNITED STATES PATENT AND TRADEMARK OFFICE

Patent Application for

METHOD FOR REDUCING EMISSIONS  
FROM EVAPORATIVE EMISSIONS CONTROL SYSTEMS

*SwA*

*BACKGROUND OF THE INVENTION*

1. Field of the Invention

This invention relates to a method for reducing emissions from evaporative control systems including activated carbon particulate-filled canisters and adsorptive monolith-containing canisters, which monoliths include activated carbon, and to using said adsorbing canisters to remove volatile organic compounds, and other chemical agents from fluid streams. More particularly, this invention relates to using said vapor-adsorbing materials in hydrocarbon fuel consuming engines.

2. Description of Related Art (Including Information Disclosed Under 37 CFR 1.97 and 37 CFR 1.98)

(a) *Standard Working Capacity Adsorbents*

Evaporation of gasoline from motor vehicle fuel systems is a major potential source of hydrocarbon air pollution. The automotive industry is challenged to design engine components and systems to contain, as much as possible, the almost one billion gallons of gasoline evaporated from fuel systems each year in the United States alone. Such emissions can be controlled by canister systems that employ activated carbon to adsorb and hold the vapor that evaporates. Under certain modes of engine operation, the adsorbed hydrocarbon vapor is periodically removed from the carbon by drawing air through the canister and burning the desorbed vapor in the engine. The regenerated carbon is then ready to adsorb additional vapor. Under EPA mandate, such control systems have been employed in the U.S. for about 30 years,

and during that time government regulations have gradually reduced the allowable emission levels for these systems. In response, improvements in the control systems have been largely focused on improving the capacity of the activated carbon to hold hydrocarbon vapor. For example, current canister systems, containing activated carbon of uniform capacity, are readily capable of capturing and releasing 100 grams of vapor during adsorption and air purge regeneration cycling. These canister systems also must have low flow restrictions in order to accommodate the bulk flow of displaced air and hydrocarbon vapor from the fuel tank during refueling. Improvements in activated carbons for automotive emission control systems are disclosed in U. S. Patent Nos.: 4,677,086; 5,204,310; 5,206,207; 5,250,491; 5,276,000; 5,304,527; 5,324,703; 5,416,056; 5,538,932; 5,691,270; 5,736,481; 5,736,485; 5,863,858; 5,914,294; 6,136,075; 6,171,373; 6,284,705.

A typical canister employed in a state of the art auto emission control system is shown in Figure 1. Canister 1 includes support screen 2, dividing wall 3, a vent port 4 to the atmosphere (for when the engine is off), a vapor source connection 5 (from the fuel tank), a vacuum purge connection 6 (for when the engine is running), and adsorbent material fill 7.

Other basic auto emission control system canisters are disclosed in U. S. Patent Nos.: 5,456,236; 5,456,237; 5,460,136; and 5,477,836.

Typical carbons for evaporative emission canisters are characterized by standard measurements of bed packing density ("apparent density," g/mL), equilibrium saturation capacity for 100% butane vapor ("butane activity," g/100g-carbon), and purgeability ("butane ratio"), specifically, the proportion of adsorbed butane from the saturation step which can be recovered from the carbon by an air purge step. The multiplicative product of these three properties yields a measure of the carbon's effective butane "working capacity" ("BWC", g/dL),

2

3

measured by ASTM D5228-92, which has been established in the art as a good predictor of the canister working capacity for gasoline vapors. Carbons that excel for this application have high BWC, typically 9 to 15+ g/dL BWC, as a result of high saturation capacities on a volumetric-basis for butane (the product of density and butane activity), and high butane ratios (>0.85). In terms of isothermal equilibrium adsorption capacities across all vapor concentrations, these carbons characteristically have high incremental capacity as a function of increased vapor concentration (*i.e.*, isotherm curved upward on a semi-log graph). This isotherm upward curve reflects the high working capacity performance feature of these carbons, in that gasoline vapors are adsorbed in high quantity at high concentrations but readily released in high concentration to an air purge stream. In addition, these carbons tend to be granular (somewhat irregularly shaped) or cylindrical pellet, typically of a size just about 1-3 mm in diameter. It has been found that somewhat larger sizes hinder diffusional transport of vapors into and out of the carbon particle during dynamic adsorb and purge cycles. On the other hand, somewhat smaller size particles have unacceptably high flow restriction for displaced air and hydrocarbon vapors during refueling.

(b) *Diurnal Breathing Loss (DBL) Requirements*

Recently, regulations have been promulgated that require a change in the approach with respect to the way in which vapors must be controlled. Allowable emission levels from canisters would be reduced to such low levels that the primary source of emitted vapor, the fuel tank, is no longer the primary concern, as current conventional evaporative emission control appears to have achieved a high efficiency of removal. Rather, the concern now is actually the hydrocarbon left on the carbon adsorbent itself as a residual "heel" after the regeneration (purge) step. Such emissions typically occur when a vehicle has been parked and subjected to

diurnal temperature changes over a period of several days, commonly called "diurnal breathing losses." Now, the California Low Emission Vehicle Regulation makes it desirable for these diurnal breathing loss (DBL) emissions from the canister system to be below 10 mg ("PZEV") for a number of vehicles beginning with the 2003 model year and below 50 mg, typically below 20 mg, ("LEV-II") for a larger number of vehicles beginning with the 2004 model year. ("PZEV" and "LEV-II" are criteria of the California Low Emission Vehicle Regulation.)

While standard carbons used in the commercial canisters excel in terms of working capacity, these carbons are unable to meet DBL emission targets under normal canister operation. Furthermore, none of the standard measures of working capacity properties correlate with DBL emission performance. Nonetheless, one option for meeting emission targets is to significantly increase the volume of purge gas during regeneration in order to reduce the amount of residual hydrocarbon heel in the carbon bed and thereby reduce subsequent emissions. This strategy, however, has the drawback of complicating management of the fuel/air mixture to the engine during purge regeneration and tends to adversely affect tailpipe emissions, *i.e.*, moving or redefining the problem rather than solving it. (See U. S. Patent No. 4,894,072.)

Another option is to design the carbon bed so that there is a relatively low cross-sectional area on the vent-side of the canister system (the first portion of the bed to encounter purge air), either by redesign of the existing canister dimensions or by the installation of a supplemental, auxiliary vent-side canister of appropriate dimensions. This alternative has the effect of locally reducing residual hydrocarbon heel by increasing the intensity of purge for that vent-side portion of the bed, thereby improving its ability to retain vapors that would otherwise be emitted from the canister system under diurnal breathing conditions. The drawback is that

there is a useful limit to which a portion of the bed can be elongated at reduced cross-sectional area without otherwise incurring excessive flow restriction by the canister system. In practice, this limit does not allow employing a sufficiently narrowed and elongated geometry to meet emission targets. (See U. S. Patent No. 5,957,114.)

Another option for increasing the purge efficiency of a fuel vapor/air mixture fraction adsorbed in the pores of the adsorbent material is suggested by the teachings of U. S. Patent Nos. 6,098,601 and 6,279,548 by providing a heating capability internal of the canister, or a section thereof, either to increase pressure in the vapor storage canister to expel hot vapor through the vapor/purge conduit back into the fuel tank where it condenses at the lower ambient temperature therein ('601) or to increase the purging efficiency of hydrocarbons from the heated adsorbent material and carry the purged fuel vapor to the induction system of an associated engine ('548). However, this increases the complexity of control system management, and there appears some inherent safety concerns in providing heating internal of a canister for trapping fuel vapors.

Thus, an acceptable remedy, which does not have drawbacks as the cited alternative approaches, is greatly desired. It is submitted that the invention disclosed and claimed herein provides the desired solution.

*SUMMARY OF THE INVENTION*

An invention is disclosed for sharply reducing diurnal breathing loss emissions from evaporative emissions canisters by the use of multiple layers, or stages, of adsorbents. On the fuel source-side of the canister, standard high working capacity carbons are preferred. On the vent-side, the preferred adsorbent volume exhibits a flat or flattened adsorbent isotherm on a volumetric basis in addition to certain characteristically desirable adsorptive properties across



broad vapor concentrations, specifically relatively low incremental capacity at high concentration vapors compared with the fuel source-side adsorbent volume. Two approaches are described for attaining the preferred properties for the vent-side adsorbent volume. One approach is to use a filler and/or bed voidages as a volumetric diluent for flattening an isotherm. A second approach is to employ an adsorbent with the desired isotherm properties and to process it into an appropriate shape or form without necessarily requiring any special provision for dilution. Both such approaches provide a substantially lower emissions canister system without a significant loss in working capacity or an increase in flow restriction compared with prior art adsorbents used for automotive emissions control.

*BRIEF DESCRIPTION OF THE DRAWINGS*

Figure 1 shows, in cross-section, a prior art canister system.

Figure 2 shows, in cross-section, one embodiment of the invention canister comprising multiple adsorbents.

Figure 3 shows butane isotherm properties for different activated carbon adsorbents.

*DESCRIPTION OF THE PREFERRED EMBODIMENT(S)*

The disclosed invention relates to the use of multiple beds (or layers, stages, or chambers) of adsorbent materials, which, in combination, significantly reduce DBL emissions while maintaining the high working capacity and low flow restriction properties of the canister system. (See Figure 2.) These adsorbents include activated carbon from a variety of raw materials, including wood, peat, coal, coconut, synthetic or natural polymer, and a variety of processes, including chemical and/or thermal activation, as well as inorganic adsorbents, including molecular sieves, porous alumina, pillared clays, zeolites, and porous silica, and organic adsorbents, including porous polymers. The adsorbents may be in granular, spherical,

1010055-0330E

or pelletized cylindrical shapes, or may be extruded into special thin-walled cross-sectional shapes, such as hollow-cylinder, star, twisted spiral, asterisk, configured ribbons, or other shapes within the technical capabilities of the art. In shaping, inorganic and/or organic binders may be used. The adsorbents may be formed into a monolith or honeycomb part. The adsorbents may be incorporated into a canister as one or more layers, or separate chambers, or they may be inserted in the fluid stream flow as auxiliary canister beds.

One common feature for all of these approaches is to have a vent-side adsorbent with a relatively flat-shaped isotherm. This isotherm shape is important for reasons related to purge efficiency across the adsorbent bed depth. For an adsorbent with a flat adsorption isotherm, the concentration of hydrocarbon vapor in equilibrium with adsorbed hydrocarbon, by definition, decreases further as the adsorbed hydrocarbon is removed compared with an adsorbent with a more steeply sloped isotherm. Thus, when such a material is employed as an adsorbent volume on the vent-side region of a canister, purge is able to reduce the vapor concentration in the area of the purge inlet to a very low level. Since it is the vapor near the purge inlet that eventually emerges as bleed, decreasing this concentration reduces the bleed emission level. The degree of removal of adsorbed hydrocarbon during purge is determined by the difference between the concentration of hydrocarbon picked up in the purge gas and the concentration in equilibrium with the adsorbent at any point in the bed. Thus, adsorbent in the immediate vicinity of the purge inlet will be most thoroughly regenerated. At points deeper in the adsorbent bed, less hydrocarbon will be removed because the purge gas will already contain hydrocarbon removed from previous points in the bed. An adsorbent with a flatter adsorption isotherm will give up less vapor into the purge stream and this purge will then be more efficient in reducing vapor concentrations deeper into the bed. Therefore, for a given quantity of purge gas, it will be

possible to reduce the vapor concentration in a volume of adsorbent with a flat adsorption isotherm to a lower level than the concentration in the same volume of an adsorbent with a steep adsorption isotherm. Bleed emission from such a volume will therefore be lower when the adsorbent has a flatter adsorption isotherm.

A region within a canister containing particulate or in an adsorbent-containing monolith with the preferred adsorption isotherm properties for achieving low bleed emission levels will, however, have a relatively low adsorption working capacity compared to the activated carbons commonly used in automotive evaporative emission control. For example, the BWC of a low capacity adsorbent will be about 6 g/dL compared to the 9 g/dL to 15+ g/dL range as used in typical automotive carbons. Therefore, in order to maintain the required hydrocarbon capacity for normal emission control system operation, the low-bleed adsorbent will be used in a vent-side auxiliary region within the canister or outside the canister in combination with an fuel source-side region containing a volume of the high capacity carbon normally employed. When two different adsorbents are used, for example, system design will involve providing sufficient volume of the high capacity carbon in the main part, or fuel source-side, of an emission control canister to achieve the desired working capacity, and a sufficient volume of the low-bleed adsorbent to contain vapor emitted from the main bed to such an extent that such vapor does not materially affect the bleed emissions from the low-bleed adsorbent.

In the context of the invention, "monolith" is intended to include foams, woven and non-woven fibers, mats, blocks and bound aggregates of particulates.

It is notable that the emission of vapor from the main, high-capacity fuel source-side volume of adsorbent into the auxiliary lower capacity vent-side volume is significantly affected by the presence of that vent-side volume. During purge, a vent-side adsorbent volume having a

flat adsorption isotherm will give up a relatively small hydrocarbon load into the purge gas. Therefore, the concentration of vapor carried by the purge gas will be low as it emerges from the low-bleed vent-side volume and enters the high-capacity, fuel source-side volume. This allows good regeneration of the high-capacity adsorbent in the vicinity of the junction of the two adsorbent volumes, and helps protect the vent-side volume from emissions from the fuel source-side region of the canister during diurnal breathing flow. Specifically, the greater regeneration efficiency of the fuel source-side volume reduces diurnal emissions by retarding the rate of bulk phase diffusion across the flow length of the canister system. Since bulk phase diffusion is a major mode of vapor transport during diurnal breathing conditions, by reducing the vapor concentration difference across the flow length of the canister system by enhanced regeneration, the redistribution of vapors within the canister system and subsequent emissions into the vent-side volume and out of the vent port are reduced.

Examples of adsorbents with isotherms having the preferred shape to provide low bleed performance are compared with standard canister-fill carbons (Westvaco Corporation's BAX 1100 and BAX 1500) in Figure 3. It is important to note that, as shown in this figure, the isotherm properties must be defined in terms of volumetric capacity. On this basis, the preferred low-bleed adsorbent portion will have an incremental n-butane capacity of less than about 35 g/liter between 5 and 50 volume percent n-butane vapor concentration.

While in some instances, known adsorbents may have the preferred properties for the vent-side, these adsorbents would not be expected to be useful in an evaporative canister. In some cases, these materials have low purgeability (butane ratio less than 0.85) and low working capacity (BWC less than 9 g/dL) as measured by the standard BWC test for qualifying canister carbons. Common wisdom and experience in the art associate low butane ratio with high

residual hydrocarbon heel, which is the potential source for high emissions. Furthermore, low BWC adsorbents were not considered useful for inclusion into a canister system as working capacity for gasoline vapors would be assumed impaired, with no expectation that there would be a utility for reducing emissions. In fact, one preferred embodiment of this invention, lower capacity adsorbents have BWC values preferably below 8 g/dL, which is well below the 9-15+ g/dL BWC level normally deemed suitable for use in evaporative emission control canister systems. The preferred selection of these low BWC materials for inclusion into a canister system as a vent-side layer to produce low emissions was only realized once the dynamics within the adsorbent bed were realized (*i.e.*, the significance of low residual vapor concentration within the vent-side bed volume and the interactive effect that the vent-side bed volume has on the distribution and diffusion of vapor across the entire canister system during the diurnal breathing loss period).

Therefore, it has been found that the preferred vent-side adsorbent properties, in addition to a relatively low BWC, includes butane ratios between 0.40 and 0.98, which in total are substantially different properties compared with adsorbents previously conceived as useful for these canister systems.

The proposed alternative approaches described above are shown to be effective in canister bleed emission control in the following examples. One approach for preparing the vent-side adsorbent is to volumetrically dilute a high working capacity adsorbent so that its resulting isotherm is flattened on a volumetric basis. A second approach is to begin with an adsorbent that has the desired adsorption capacity and flat isotherm shape and process it into a shape or form, such as a pellet or honeycomb.

A particular preferred embodiment for a canister with multiple adsorbents is shown in Figure 2. Figure 2 shows a canister system comprising a primary canister body 1, a support screen 2, a dividing wall 3, a vent port 4 to the atmosphere, a vapor source connection 5, a vacuum purge connection 6, a fuel source-side region 7, vent-side canister regions 8 – 11 of varying low-capacities, supplemental canister body 12, and connecting hose 13 permitting fluid stream flow from the primary canister body 1 to the supplemental canister body 12. Additional embodiments, as discussed above, are also envisioned to be within the scope of the subject of the invention.

The desired results for the subject matter of the invention can be attained with a single vent-side uniform lower capacity adsorbent material as the subsequent adsorbent material. The option of multiples of lower capacity adsorbents with the desirable adsorptive properties across broad vapor concentrations is demonstrated merely as one embodiment.

The measures for gasoline working capacity (GWC) and emissions in the Table were derived from the Westvaco DBL test that uses a 2.1L canister. The pellet examples were tested as a 300 mL vent-side layer within the canister, with the 1800 mL of BAX 1500 pellets as the remaining canister fill. The honeycomb was tested as an auxiliary bed canister that was placed in-line with the 2.1L main canister of BAX 1500 pellets. For all examples, the canister system was uniformly first preconditioned by repetitive cycling of gasoline vapor adsorption and air purge (400 bed volumes air). This cycling generated the GWC value. Butane emissions were subsequently measured after a butane adsorption and an air purge step, specifically during a diurnal breathing loss period when the canister system was attached to a temperature-cycled fuel tank. The reported value is the 2<sup>nd</sup> day DBL emissions during an 11-hour period when the fuel tank was warmed and vapor-laden air was vented to the canister system and exhausted

20100323 09:15:53

from the vent-side adsorbent where the emissions were measured. The procedure employed for measuring DBL emissions has been described in *SAE Technical Paper 2001-01-0733*, titled "Impact and Control of Canister Bleed Emissions," by R. S. Williams and C. R. Clontz.

Example 1: Microsphere Filler Pellets. These 2 mm pellets are an example of the volumetric dilution method by adding a solid filler to the extrusion formulation. The pellets were prepared from an extrusion blend consisting of Westvaco SA-1500 powder (12.8 wt%), solid glass microsphere filler (79.7 wt% PQ Corporation A3000), bentonite clay (7.2 wt%), and phosphoric acid (0.3 wt%). The pellets were tumbled for four minutes, dried overnight at 105°C, and subsequently heat-treated in steam at 650°C for 15 minutes. An appropriate non-adsorbing filler reduces adsorption capacities across all vapor concentrations, resulting in a flattened adsorption isotherm ("Example 1" in Figure 3). Alternative methods for diluting the vent-side region are to co-mix adsorbent granules or pellets with inert filler particles of similar size, to form the extrusion paste into high voidage shapes such as hollow cylinders, asterisks, stars, or twisted, bent, or spiral ribbon pieces, or to place multiple thin layers of non-adsorbing particles or porous mats (e.g., foam), or simply trapped air space between layers of adsorbent.

Example 2: Ceramic-Bound Honeycomb. The 200 cpsi (cells per square inch) carbon-containing honeycomb is another example of the volumetric dilution method. The honeycomb in the Table was prepared according to the method described in U.S. Patent No. 5,914,294, which discloses forming an adsorptive monolith comprising the steps of (a) extruding an extrudable mixture through an extrusion die such that a monolith is formed having a shape wherein the monolith has at least one passage therethrough and the extrudable mixture comprises activated carbon, a ceramic forming material, a flux material, and water, (b) drying the extruded monolith, and (c) firing the dried monolith at a temperature and for a time period

sufficient to react the ceramic forming material together and form a ceramic matrix. The extrudable mixture is capable of maintaining the shape of the monolith after extrusion and during drying of the monolith.

In this example, the extrusion formulation ingredients partially dilute the carbon adsorbent, and in addition, the adsorbent is further diluted by the open cell structure of the extruded part. These cells create more bed voidages within the part, compared with a similar bed volume of pellets (65 vol% voidages for the honeycomb versus 35 vol% for pellets or granules). The cell structure and high bed voidages have the added advantage of imposing minimal additional flow restriction compared with a bed of pellets, thereby allowing the honeycomb to be installed to the main canister as an add-on auxiliary device of greatly reduced cross-sectional area (see supplemental canister body 12 in Figure 2).

Example 3: Special Precursor Pellets: These 2 mm pellets were prepared by selecting the adsorbent to be extruded according to its intrinsic flat isotherm adsorption properties. In this example, there was no special provision for filler in the formulation or bed voidage dilution from the extruded shape. The ingredients for the extrusion blend producing the tested activated carbon pellets consisted of SX 1 grade activated carbon produced by NORIT (93.2 wt%) and sodium carboxymethyl cellulose binder system (6.8 wt%). The pellets were tumbled for four minutes, dried overnight at 105°C, and subsequently heat-treated in air at 150°C for three hours.

As noted above, the comparisons of these activated carbon containing materials, prepared as set forth in the examples, is shown in the following Table.

20100322 07:09



TABLE

Performance, Properties, and Formulations for Alternative Vent-Side Adsorbents

T, 0150

	Filled Pellet	Ceramic-Bound Honeycomb	Special Precursor Pellet	Prior Art: High Working Capacity Carbons	
Fuel source-side BAX 1500 Volume:	1800 mL	2100 mL	1800 mL	1800 mL	1800 mL
Vent-Side Adsorbent Type:	"Ex. 1"	"Ex. 2"	"Ex. 3"	BAX 1100	BAX 1500
Vent-Side Mode:	Layer	Auxiliary Bed	Layer	Layer	Layer
Vent-Side Adsorbent Volume:	300 mL	200 mL 41mm diameter x 150 mm long, 200 cpsi	300 mL	300 mL	300 mL
<b>Canister System Performance: Westvaco DBL Test</b>					
Gasoline Working Capacity, g:	138	144	132	143	139
2 <sup>nd</sup> Day DBL Emissions, mg-C <sub>4</sub> :	29	10	13	88	221
Note:	(1)	(2)	(3)	(4)	(5)
<b>Vent-Side Properties (6)</b>					
<u>Incremental Adsorption At 25°C</u>					
5 -50 vol% butane vapor, g/L:	24	16	18	52	80
Apparent Density, g/mL:	0.869	0.355	0.453	0.358	0.284
Butane Activity, g/100g:	7.0	13.1	18.5	39.0	64.7
BWC, g/dL:	5.7	4.0	5.0	11.9	16.0
Butane Ratio:	0.929	0.852	0.593	0.852	0.868

2001-79-0150

- (1) Two DBL Tests; Averaged data for GWC (400 bed volume purge) and DBL emissions (150 bed volume purge); 2.1L canister, 1500 mL fuel source-side chamber, 600 mL vent-side chamber, fuel source-side chamber cross-sectional area 2.5 times the vent-side cross-sectional area.
- (2) Single DBL Test
- (3) Average of three DBL Tests
- (4) Average of three DBL Tests
- (5) Average of six DBL Tests
- (6) Density and BWC by ASTM standard techniques.

The Table shows data for the three examples of these two approaches compared with vent-side layers containing high working capacity carbons, BAX 1100 and BAX 1500.

Compared with the state of the art BAX carbons (the Figure 3), all three of the examples have significantly lower capacities for butane at high concentrations and considerably flatter isotherm curves.

As shown in the Table, the examples demonstrate reductions in emissions by factors of 3-22 over canisters consisting of only high working capacity carbons. There was either no loss or only a slight loss in GWC.

A further preferred embodiment of the invention method is presented in an evaporative emissions control system for a vehicle, the system comprising, in combination, a fuel tank for storing a volatile fuel, an engine having an air induction system and adapted to consume the fuel, a canister containing an initial volume of fuel vapor adsorbent material for temporarily adsorbing and storing fuel vapor from the tank, a conduit for conducting fuel vapor from the tank to a canister vapor inlet, a fuel vapor purge conduit from a canister purge outlet to the induction system of the engine, and a vent/air opening for venting the canister and for admission of air to the canister during operation of the engine induction system, wherein the canister defines a fuel vapor flow path via the canister vapor inlet through the initial volume of vapor adsorbent within a first region of the canister toward the vent/air opening, and an air flow path through a subsequent volume of adsorbent within a second region of the canister at the vent/air opening and the first region at the purge outlet, such that fuel vapor formed in the tank flows through the vapor inlet into the initial volume of adsorbent where it is adsorbed and, during operation of the engine induction system, ambient air flows in a path to and through the vent/air opening and along the air flow path in the canister through the

initial volume and the purge outlet to the induction system of the engine, the flow of air removing a portion of the adsorbed fuel vapor but leaving a residue of fuel in the initial volume, wherein at least one subsequent volume of vapor adsorbent material comprises a volume of 1% to 100% of the first volume and is located either inside of the canister within the second region thereof or outside of the canister, and wherein the initial volume of vapor adsorbent material is characterized by an incremental adsorption capacity at 25°C of greater than 35 g n-butane/L between vapor concentrations of 5 vol% and 50 vol% n-butane before routing the fluid stream through at least one subsequent volume of vapor adsorbent material wherein the subsequent volume of vapor adsorbent material is characterized by an incremental adsorption capacity at 25°C of less than 35 g n-butane/L between vapor concentrations of 5 vol% and 50 vol% n-butane.

This invention method certainly includes an embodiment wherein the second volume of vapor adsorbent material is located outside the canister in a separate subsequent canister, but in the flow path of the ambient air to the vent/air inlet and the first region.

This invention method includes an embodiment wherein the initial volume of vapor adsorbent material and the subsequent volume of vapor adsorbent material are activated carbon derived from materials selected from the group consisting of wood, peat, coal, coconut, lignite, petroleum pitch, petroleum coke, coal tar pitch, fruit pits, nut shells, sawdust, wood flour, synthetic polymer, and natural polymer having been activated by a process selected from the group consisting of chemical, thermal, and combined chemical/thermal activation methods.

The invention method includes an embodiment wherein the initial volume of vapor adsorbent material and the subsequent volume of vapor adsorbent material are inorganic

materials selected from the group consisting of zeolites, porous silica, porous alumina, pillared clays, and molecular sieves.

The invention method includes an embodiment wherein the initial volume of vapor adsorbent material and the subsequent volume of vapor adsorbent material are porous polymers.

The invention method includes an embodiment wherein the subsequent volume of vapor adsorbent material exhibits adsorption capacities achieved by volumetric dilution.

The invention method further includes an embodiment wherein the volumetric dilution is accomplished by the addition of a non-adsorbing filler as a co-ingredient by an addition process selected from the group consisting of addition with the activated carbon raw material prior to activation, addition with the adsorbent before forming into a shaped particle or monolith, and a combination thereof.

The invention method further includes an embodiment wherein the volumetric dilution is accomplished by forming the adsorbent material into high voidage shapes selected from the group consisting of stars, hollow cylinders, asterisks, spirals, cylinders, configured ribbons, and other shapes within the capabilities of the art.

The method claimed herein includes an embodiment wherein the volumetric dilution is accomplished by forming the adsorbent into a honeycomb or monolith shape.

The method claimed herein includes an embodiment wherein the volumetric dilution is accomplished by the use of inert spacer particles, foams, fibers, and screens external to the vent-side adsorbent particles and monoliths.

The method claimed herein includes an embodiment wherein the non-adsorbing filler is a solid after processing.

Also, the method claimed herein includes an embodiment wherein the non-adsorbing filler is volatilized or combusted to form voidages larger than 50Å width within the shaped particle or monolith.

The foregoing description relates to embodiments of the present invention, and changes and modifications may be made therein without departing from the scope of the invention as defined in the following claims.

2001-09-29 10:00 AM

We claim:

1. A method for reducing fuel vapor emissions in automotive evaporative emissions control systems comprising the steps of contacting the fuel vapor with an initial adsorbent volume having incremental adsorption capacity at 25°C of greater than 35 g n-butane/L between vapor concentrations of 5 vol% and 50 vol% n-butane and at least one subsequent adsorbent volume having an incremental adsorption capacity of less than 35 g n-butane/L between vapor concentrations of 5 vol% and 50 vol% n-butane.
2. The method of claim 1 comprising a single subsequent adsorbent volume.
3. The method of claim 1 comprising multiple subsequent adsorbent volumes.
4. The method of claim 2 wherein the initial adsorbent volume and the subsequent adsorbent volume are located within a single automotive evaporative emission control canister.
5. The method of claim 3 wherein the initial adsorbent volume and the subsequent adsorbent volumes are located within a single automotive evaporative emission control canister.
6. The method of claim 2 wherein the initial adsorbent volume and the subsequent adsorbent volume are located in separate canisters that are connected to permit sequential contact by the fuel vapor.
7. The method of claim 3 wherein the initial adsorbent volume and at least one subsequent adsorbent volume are located in separate canisters that are connected to permit sequential contact by the fuel vapor.
8. The method of claim 1 wherein the initial adsorbent volume and the subsequent adsorbent volume are activated carbon derived from materials selected from the group consisting of wood, peat, coal, coconut, lignite, petroleum pitch, petroleum coke, coal tar pitch, fruit pits, nut shells, sawdust, wood flour, synthetic polymer, and natural polymer having been

activated by a process selected from the group consisting of chemical, thermal, and combined chemical/thermal activation methods.

9. The method of claim 1 wherein the initial adsorbent volume and the subsequent adsorbent volume are inorganic materials selected from the group consisting of zeolites, porous silica, porous alumina, pillared clays, and molecular sieves.

10. The method of claim 1 wherein the initial adsorbent volume and the subsequent adsorbent volume are porous polymers.

11. The method of claim 1 wherein the subsequent adsorbent volume exhibits adsorption capacities achieved by volumetric dilution.

12. The method of claim 11 wherein the volumetric dilution is accomplished by the addition of a non-adsorbing filler as a co-ingredient by an addition process selected from the group consisting of addition with the activated carbon raw material prior to activation, addition with the adsorbent before forming into a shaped particle or monolith, and a combination thereof.

13. The method of claim 11 wherein the volumetric dilution is accomplished by forming the adsorbent into high voidage shapes selected from the group consisting of stars, hollow cylinders, asterisks, spirals, cylinders, and configured ribbons.

14. The method of claim 11 wherein the volumetric dilution is accomplished by forming the adsorbent into a honeycomb or monolith shape.

15. The method of claim 11 wherein the volumetric dilution is accomplished by the use of inert spacer particles, trapped air spaces, foams, fibers, and screens external to the adsorbent.

16. The method of claim 12 wherein the non-adsorbing filler is a solid after processing.
17. The method of claim 12 wherein the non-adsorbing filler is volatilized or combusted to form voidages larger than 50Å width within the shaped particle or monolith.
18. In a method of reducing fuel vapor emissions in an automotive evaporative emissions control system comprising removing at least one volatile organic compound from a volatile organic compound-containing fuel vapor by routing the fuel vapor through a vapor adsorbent, the improvement comprising sequentially routing the fuel vapor through an initial adsorbent material-containing volume wherein the initial adsorbent material is characterized by an incremental adsorption capacity at 25°C of greater than 35 g n-butane/L between vapor concentrations of 5 vol% and 50 vol% n-butane before routing the fluid stream through at least one subsequent adsorbent-containing volume prior to venting to the atmosphere wherein the subsequent adsorbent-containing volume is characterized by an incremental adsorption capacity at 25°C of less than 35 g n-butane/L between vapor concentrations of 5 vol% and 50 vol% n-butane.
19. The method of claim 18 wherein the initial adsorbent volume and the subsequent adsorbent volume are located in a single automotive evaporative emissions canister.
20. The method of claim 18 wherein the initial adsorbent volume and the subsequent adsorbent volume are located in separate canisters that are connected to permit sequential contact by the fuel vapor.
21. The method of claim 18 wherein the initial adsorbent volume and the subsequent adsorbent volume are activated carbon derived from materials selected from the group consisting of wood, peat, coal, coconut, lignite, petroleum pitch, petroleum coke, coal tar pitch,



fruit pits, nut shells, sawdust, wood flour, synthetic polymer, and natural polymer and activated by chemical and/or thermal activation methods.

22. The method of claim 18 wherein the initial adsorbent volume and the subsequent adsorbent volume are inorganic materials selected from the group consisting of zeolites, porous silica, and molecular sieves.

23. The method of claim 18 wherein the initial adsorbent volume and the subsequent adsorbent volume are porous polymers.

24. The method of claim 18 wherein the subsequent adsorbent volume exhibits adsorption capacities achieved by volumetric dilution.

25. The method of claim 24 wherein the volumetric dilution is accomplished by the addition of a non-adsorbing filler as a co-ingredient by an addition process selected from the group consisting of addition with the activated carbon raw material prior to activation, addition with the adsorbent before forming into a shaped particle or monolith, and a combination thereof.

26. The method of claim 24 wherein the volumetric dilution is accomplished by forming the adsorbent into high voidage shapes selected from the group consisting of stars, hollow cylinders, asterisks, spirals, cylinders, and configured ribbons.

27. The method of claim 24 wherein the volumetric dilution is accomplished by forming the adsorbent into a honeycomb or monolith shape.

28. The method of claim 24 wherein the volumetric dilution is accomplished by the use of inert spacer particles, trapped air spaces, foams, fibers, and screens external to the adsorbent.

29. The method of claim 25 wherein the non-adsorbing filler is a solid after processing.
30. The method of claim 25 wherein the non-adsorbing filler is volatilized or combusted to form voidages larger than 50Å width within the shaped particle or monolith.

2001-79-250701

PRINT OF DRAWINGS  
AS ORIGINALLY FILED

FIGURE 1

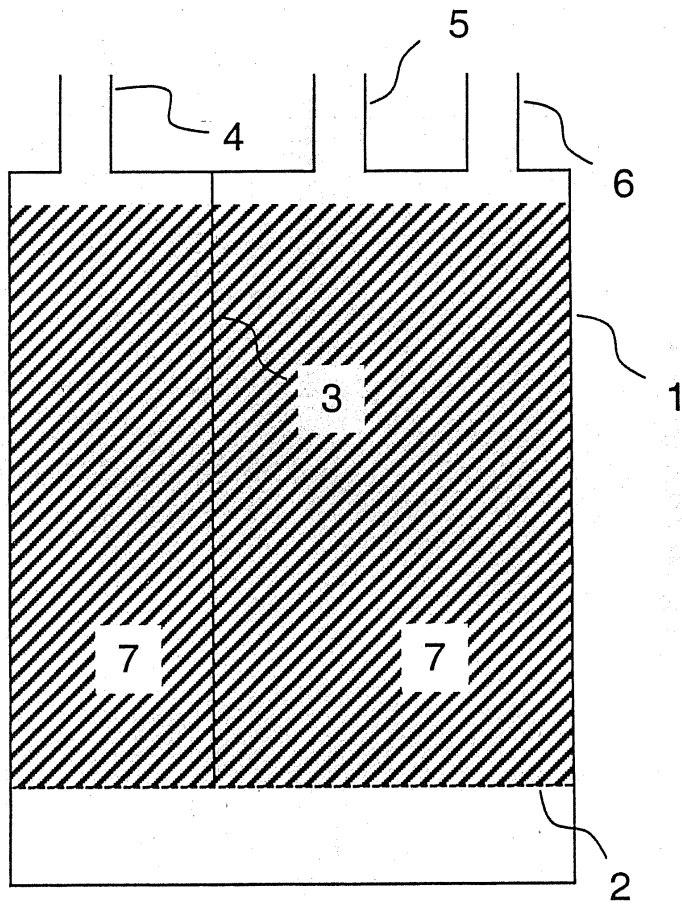

20250729 09:18:02

NT OF DRAWINGS  
ORIGINALLY FILED

FIGURE 2

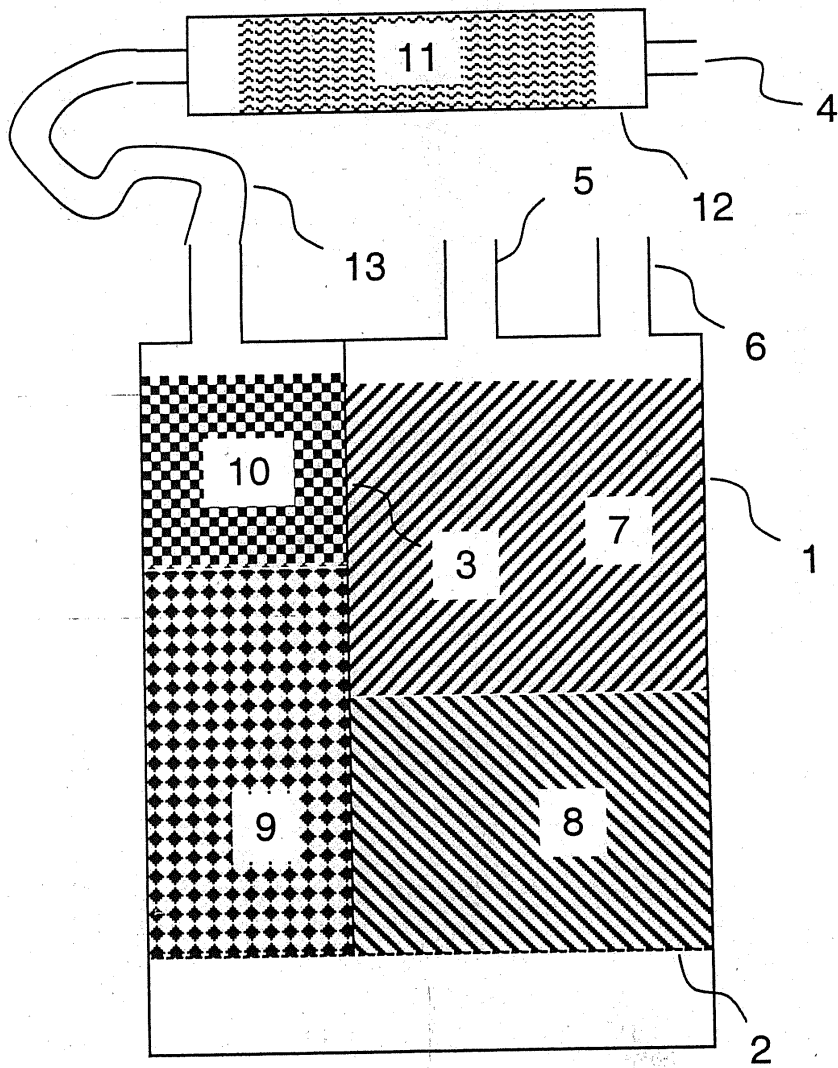

RECEIVED - 29200101

PRINT OF DRAWINGS  
AS ORIGINALLY FILED

FIGURE 3

n-Butane Adsorption Isotherm at 25°C

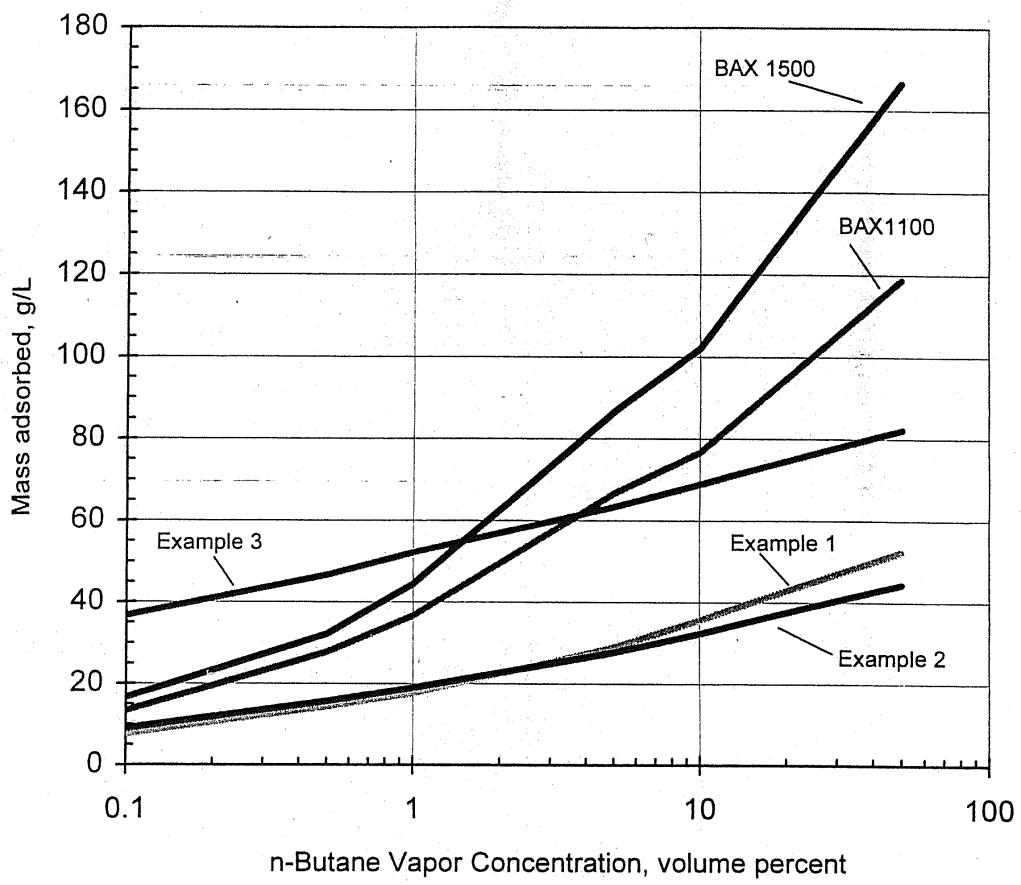

2025 RELEASE UNDER E.O. 14176



**UNITED STATES PATENT AND TRADEMARK OFFICE**

COMMISSIONER FOR PATENTS  
 UNITED STATES PATENT AND TRADEMARK OFFICE  
 WASHINGTON, D.C. 20231  
 www.uspto.gov

#2

APPLICATION NUMBER	FILING/RECEIPT DATE	FIRST NAMED APPLICANT	ATTORNEY DOCKET NUMBER
10/100,362	03/18/2002	Laurence H. Hiltzik	CHR 2001-79

CONFIRMATION NO. 3899

## FORMALITIES LETTER



\*OC000000007944995\*

Westvaco Corporation  
 5255 Virginia Avenue  
 P.O. Box 118005  
 Charleston, SC 29423-8005

Date Mailed: 04/24/2002

**NOTICE TO FILE MISSING PARTS OF NONPROVISIONAL APPLICATION**

FILED UNDER 37 CFR 1.53(b)

*Filing Date Granted***Items Required To Avoid Abandonment:**

An application number and filing date have been accorded to this application. The item(s) indicated below, however, are missing. Applicant is given **TWO MONTHS** from the date of this Notice within which to file all required items and pay any fees required below to avoid abandonment. Extensions of time may be obtained by filing a petition accompanied by the extension fee under the provisions of 37 CFR 1.136(a).

- The oath or declaration is missing.  
*A properly signed oath or declaration in compliance with 37 CFR 1.63, identifying the application by the above Application Number and Filing Date, is required.*
- To avoid abandonment, a late filing fee or oath or declaration surcharge as set forth in 37 CFR 1.16(l) of \$130 for a non-small entity, must be submitted with the missing items identified in this letter.

**Items Required To Avoid Processing Delays:**

The item(s) indicated below are also required and should be submitted with any reply to this notice to avoid further processing delays.

**SUMMARY OF FEES DUE:**

Total additional fee(s) required for this application is **\$130** for a Large Entity

- **\$130** Late oath or declaration Surcharge.

*A copy of this notice **MUST** be returned with the reply.*

*Jarayne A.*  
Customer Service Center  
Initial Patent Examination Division (703) 308-1202

PART 3 - OFFICE COPY

#3

Express Mail No. EF370311229US

PTO/SB/21 (08-00)

Approved for use through 10/31/2002. OMB 0651-0031

U.S. Patent and Trademark Office: U.S. DEPARTMENT OF COMMERCE  
Under the Paperwork Reduction Act of 1995, no persons are required to respond to a collection of information unless it displays a valid OMB control number.

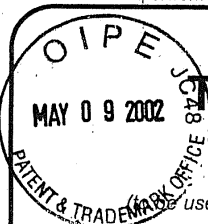
 <p><b>TRANSMITTAL FORM</b> (to be used for all correspondence after initial filing)</p>	Application Number	10/100,362	
	Filing Date	03/18/2002	
	First Named Inventor	L. H. Hiltzik	
	Group Art Unit		
	Examiner Name		
Total Number of Pages in This Submission	18	Attorney Docket Number	CHR 2001-79

ENCLOSURES (check all that apply)		
<input checked="" type="checkbox"/> Fee Transmittal Form	<input type="checkbox"/> Assignment Papers (for an Application)	<input type="checkbox"/> After Allowance Communication to Group
<input checked="" type="checkbox"/> Fee Attached	<input type="checkbox"/> Drawing(s)	<input type="checkbox"/> Appeal Communication to Board of Appeals and Interferences
<input checked="" type="checkbox"/> Amendment/Reply Preliminary	<input type="checkbox"/> Licensing-related Papers	<input type="checkbox"/> Appeal Communication to Group (Appeal Notice, Brief, Reply Brief)
<input type="checkbox"/> After Final	<input checked="" type="checkbox"/> Petition to make Special Declaration in Support	<input type="checkbox"/> Proprietary Information
<input type="checkbox"/> Affidavits/declaration(s)	<input type="checkbox"/> Petition to Convert to a Provisional Application	<input type="checkbox"/> Status Letter
<input type="checkbox"/> Extension of Time Request	<input checked="" type="checkbox"/> Power of Attorney, Revocation	<input checked="" type="checkbox"/> Other Enclosure(s) (please identify below):
<input type="checkbox"/> Express Abandonment Request	<input type="checkbox"/> Change of Correspondence - Address	Certificate of Mailing under CFR 1.10
<input type="checkbox"/> Information Disclosure Statement	<input type="checkbox"/> Terminal Disclaimer	One return postcard
<input type="checkbox"/> Certified Copy of Priority Document(s)	<input type="checkbox"/> Request for Refund	
<input checked="" type="checkbox"/> Response to Missing Parts/Incomplete Application	<input type="checkbox"/> CD, Number of CD(s) _____	
<input checked="" type="checkbox"/> Response to Missing Parts under 37 CFR 1.52 or 1.53	Remarks	

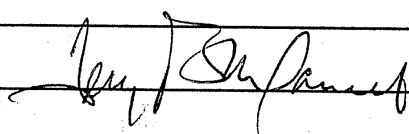
SIGNATURE OF APPLICANT, ATTORNEY, OR AGENT	
Firm or Individual name	Terry B. McDaniel      Registration No. 28,444
Signature	
Date	05/09/2002

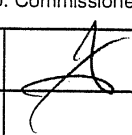
CERTIFICATE OF MAILING	
I hereby certify that this correspondence is being deposited with the United States Postal Service with sufficient postage as first class mail in an envelope addressed to: Commissioner for Patents, Washington, DC 20231 on this date: <input type="text"/>	
Typed or printed name	
Signature	Date

Burden Hour Statement: This form is estimated to take 0.2 hours to complete. Time will vary depending upon the needs of the individual case. Any comments on the amount of time you are required to complete this form should be sent to the Chief Information Officer, U.S. Patent and Trademark Office, Washington, DC 20231. DO NOT SEND FEES OR COMPLETED FORMS TO THIS ADDRESS. SEND TO: Assistant Commissioner for Patents, Washington, DC 20231.



#3

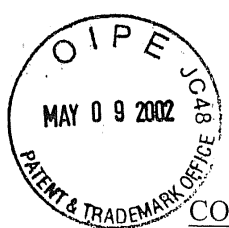

Express Mail No. EF370311229US  
Case Docket No. CHR 2001-79

U. S. Serial (Non-Provisional) No. 10/100,362

COMBINED DECLARATION, POWER OF ATTORNEY,  
AND PETITION IN ORIGINAL APPLICATION

As a below named inventor, I hereby declare that:  
My residence, post office address and citizenship are as stated below next to my  
name; that

I verily believe that I am an original first and joint inventor of the subject matter that  
is claimed, and for which a patent is sought on the invention entitled **Method for Reducing  
Emissions from Evaporative Emissions Control Systems** described and claimed in the  
specification, that I hereby state that I have reviewed and understand the contents of the  
specification, including the claims;

**That I hereby claim the benefit under 35 U.S.C. 119(e) of the United States Provisional  
Application Serial No. 60/335,897, filed November 21, 2001;**

That I do not know and do not believe that this invention was ever known or used in the  
United States before my or our invention thereof, or patented or described in any printed publication  
in any country before my or our invention thereof for more than one year prior to this application, or  
in public use or on sale in the United States more than one year prior to this application, that this  
invention has not been patented or made the subject of an inventor's certificate in any country  
foreign to the United States prior to the date of this application on an application filed by me or my  
legal representatives or assigns more than twelve months before this application, that I acknowledge  
my duty to disclose information of which I am aware, which is material to patentability as defined in  
37 Code of Federal Regulations § 1.56, and which is material to the examination of this application,  
namely, information where there is a substantial likelihood that a reasonable Examiner would  
consider it important in deciding whether to allow the application to issue as a patent; and that no  
application for patent or inventor's certificate on this invention has been filed by me or my  
representatives or assigns in any country foreign to the United States.

And I hereby appoint --

Terry B. McDaniel  
Registration No. 28,444  
MeadWestvaco Corporation  
5255 Virginia Avenue  
Post Office Box 118005  
Charleston, South Carolina 29423-8005  
(WITH WHOM CORRESPONDENCE IS TO BE DIRECTED)

Express Mail No. EF370311229US

Case Docket No. CHR 2001-79

U. S. Serial (Non-Provisional) No. 10/100,362

and Daniel B. Reece, IV, Registration No. 33,998, MeadWestvaco Corporation, 5255 Virginia Avenue, Post Office Box 118005, Charleston, South Carolina 29423-8005, and each of them, my attorneys, with full powers of substitution and revocation, to prosecute this application and to transact all business in the Patent and Trademark Office connected therewith. I further recognize and acknowledge that the true party in interest of the invention described and claimed herein is the assignee, Westvaco Corporation.

Wherefore I pray that Letters Patent be granted to us for the invention or discovery described and claimed in the foregoing specification and claims, and I hereby subscribe my name to the foregoing specification and claims, declaration, power of attorney, and this petition.

I, the undersigned petitioner, declare further that all statements made herein of my own knowledge are true and all statements made on information and belief are believed to be true; and further that these statements were made with the knowledge that willful false statements and the like so made are punishable by fine or imprisonment, or both, under Section 1001 of Title 18 of the United States Code and that such willful false statements may jeopardize the validity of the application or any patent issuing thereon.

Laurence H. Hiltzik

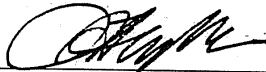

3/26/2002

FULL NAME OF SOLE OR FIRST INVENTOR INVENTOR'S SIGNATURE

DATE

191 Broad Street, Charleston, SC 29401

RESIDENCE

United States

CITIZENSHIP

191 Broad Street, Charleston, SC 29401

POST OFFICE ADDRESS

Jacek Z. Jagiello

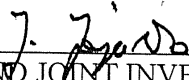

3/26/02

FULL NAME OF SECOND JOINT INVENTOR INVENTOR'S SIGNATURE

DATE

6240 Old Point Road., Apt. # 41, Charleston, SC 29406

RESIDENCE

United States

CITIZENSHIP

6240 Old Point Road., Apt. # 41, Charleston, SC 29406

POST OFFICE ADDRESS

Express Mail No. EF370311229US  
Case Docket No. CHR 2001-79  
U. S. Serial (Non-Provisional) No. 10/100,362

Edward D. Tolles Edward D. Tolles 3/26/02  
FULL NAME OF THIRD JOINT INVENTOR INVENTOR'S SIGNATURE DATE

2 Lampton Road, Charleston, SC 29407 United States  
RESIDENCE CITIZENSHIP

2 Lampton Road, Charleston, SC 29407  
POST OFFICE ADDRESS

Roger S. Williams Roger Williams 3/28/02  
FULL NAME OF FOURTH JOINT INVENTOR INVENTOR'S SIGNATURE DATE

900 Boyer Lane, Lexington, VA 24450 United States  
RESIDENCE CITIZENSHIP

900 Boyer Lane, Lexington, VA 24450  
POST OFFICE ADDRESS

05-10-02

~~MPA~~  
#3



EXPRESS MAIL NO. EF370311229US  
Case Docket No. CHR 01-79  
Serial No.: 10/100,362  
File Date: 3/18/02

CERTIFICATE UNDER 37 C.F.R. 1.10(a)

I hereby certify that this correspondence is being deposited with the United States Postal Service as Express Mail in an envelope addressed to the Assistant Commissioner for Patents, Washington, DC 20231, on May 9, 2002.

  
\_\_\_\_\_  
Terry B. McDaniel  
Attorney for the Applicants  
Registration No. 28,444

#3



EXPRESS MAIL NO. EF370311229US  
Case Docket No. CHR 01-79  
Serial No.: 10/100,362  
File Date: 3/18/02

CERTIFICATE UNDER 37 C.F.R. 1.10(a)

I hereby certify that this correspondence is being deposited with the United States Postal Service as Express Mail in an envelope addressed to the Assistant Commissioner for Patents, Washington, DC 20231, on May 9, 2002.

  
\_\_\_\_\_  
Terry B. McDanel  
Attorney for the Applicants  
Registration No. 28,444

Express Mail No. EF370311229US

PTO/SB/17 (10-01)

Approved for use through 10/31/2002. OMB 0651-0032

Under the Paperwork Reduction Act of 1995, no persons are required to respond to a collection of information unless it displays a valid OMB control number.

<p><b>FEE TRANSMITTAL</b>  <b>for FY 2002</b>          Patent fees are subject to annual revision.</p>	<b>Complete if Known</b>		
	Application Number	10/100,362	
	Filing Date	03/18/2002	
	First Named Inventor	L. H. Hiltzik	
	Examiner Name		
TOTAL AMOUNT OF PAYMENT (\$)	130.00	Group Art Unit	
		Attorney Docket No.	CHR 2001-79

<b>METHOD OF PAYMENT</b>		<b>FEE CALCULATION (continued)</b>																																																																																																																																																																																								
<p>1. <input checked="" type="checkbox"/> The Commissioner is hereby authorized to charge indicated fees and credit any overpayments to:</p> <p>Deposit Account Number: 23-1160</p> <p>Deposit Account Name: _____</p> <p><input type="checkbox"/> Charge Any Additional Fee Required Under 37 CFR 1.16 and 1.17</p> <p><input type="checkbox"/> Applicant claims small entity status. See 37 CFR 1.27</p>		<p>3. <b>ADDITIONAL FEES</b></p> <table border="1"> <thead> <tr> <th>Fee Code</th> <th>Large Entity (\$)</th> <th>Small Entity (\$)</th> <th>Fee Description</th> <th>Fee Paid</th> </tr> </thead> <tbody> <tr><td>105</td><td>130</td><td>205</td><td>65</td><td>Surcharge - late filing fee or oath</td><td>130.00</td></tr> <tr><td>127</td><td>50</td><td>227</td><td>25</td><td>Surcharge - late provisional filing fee or cover sheet</td><td></td></tr> <tr><td>139</td><td>130</td><td>139</td><td>130</td><td>Non-English specification</td><td></td></tr> <tr><td>147</td><td>2,520</td><td>147</td><td>2,520</td><td>For filing a request for <i>ex parte</i> reexamination</td><td></td></tr> <tr><td>112</td><td>920*</td><td>112</td><td>920*</td><td>Requesting publication of SIR prior to Examiner action</td><td></td></tr> <tr><td>113</td><td>1,840*</td><td>113</td><td>1,840*</td><td>Requesting publication of SIR after Examiner action</td><td></td></tr> <tr><td>115</td><td>110</td><td>215</td><td>55</td><td>Extension for reply within first month</td><td></td></tr> <tr><td>116</td><td>400</td><td>216</td><td>200</td><td>Extension for reply within second month</td><td></td></tr> <tr><td>117</td><td>920</td><td>217</td><td>460</td><td>Extension for reply within third month</td><td></td></tr> <tr><td>118</td><td>1,440</td><td>218</td><td>720</td><td>Extension for reply within fourth month</td><td></td></tr> <tr><td>128</td><td>1,960</td><td>228</td><td>980</td><td>Extension for reply within fifth month</td><td></td></tr> <tr><td>119</td><td>320</td><td>219</td><td>160</td><td>Notice of Appeal</td><td></td></tr> <tr><td>120</td><td>320</td><td>220</td><td>160</td><td>Filing a brief in support of an appeal</td><td></td></tr> <tr><td>121</td><td>280</td><td>221</td><td>140</td><td>Request for oral hearing</td><td></td></tr> <tr><td>138</td><td>1,510</td><td>138</td><td>1,510</td><td>Petition to institute a public use proceeding</td><td></td></tr> <tr><td>140</td><td>110</td><td>240</td><td>55</td><td>Petition to revive - unavoidable</td><td></td></tr> <tr><td>141</td><td>1,280</td><td>241</td><td>640</td><td>Petition to revive - unintentional</td><td></td></tr> <tr><td>142</td><td>1,280</td><td>242</td><td>640</td><td>Utility issue fee (or reissue)</td><td></td></tr> <tr><td>143</td><td>460</td><td>243</td><td>230</td><td>Design issue fee</td><td></td></tr> <tr><td>144</td><td>620</td><td>244</td><td>310</td><td>Plant issue fee</td><td></td></tr> <tr><td>122</td><td>130</td><td>122</td><td>130</td><td>Petitions to the Commissioner</td><td></td></tr> <tr><td>123</td><td>50</td><td>123</td><td>50</td><td>Processing fee under 37 CFR 1.17(q)</td><td></td></tr> <tr><td>126</td><td>180</td><td>126</td><td>180</td><td>Submission of Information Disclosure Stmt</td><td></td></tr> <tr><td>581</td><td>40</td><td>581</td><td>40</td><td>Recording each patent assignment per property (times number of properties)</td><td></td></tr> <tr><td>146</td><td>740</td><td>246</td><td>370</td><td>Filing a submission after final rejection (37 CFR § 1.129(a))</td><td></td></tr> <tr><td>149</td><td>740</td><td>249</td><td>370</td><td>For each additional invention to be examined (37 CFR § 1.129(b))</td><td></td></tr> <tr><td>179</td><td>740</td><td>279</td><td>370</td><td>Request for Continued Examination (RCE)</td><td></td></tr> <tr><td>169</td><td>900</td><td>169</td><td>900</td><td>Request for expedited examination of a design application</td><td></td></tr> <tr><td colspan="4">Other fee (specify) _____</td><td></td></tr> <tr><td colspan="4" style="text-align: right;"><b>SUBTOTAL (3) (\$)</b></td><td><b>130.00</b></td></tr> </tbody> </table>		Fee Code	Large Entity (\$)	Small Entity (\$)	Fee Description	Fee Paid	105	130	205	65	Surcharge - late filing fee or oath	130.00	127	50	227	25	Surcharge - late provisional filing fee or cover sheet		139	130	139	130	Non-English specification		147	2,520	147	2,520	For filing a request for <i>ex parte</i> reexamination		112	920*	112	920*	Requesting publication of SIR prior to Examiner action		113	1,840*	113	1,840*	Requesting publication of SIR after Examiner action		115	110	215	55	Extension for reply within first month		116	400	216	200	Extension for reply within second month		117	920	217	460	Extension for reply within third month		118	1,440	218	720	Extension for reply within fourth month		128	1,960	228	980	Extension for reply within fifth month		119	320	219	160	Notice of Appeal		120	320	220	160	Filing a brief in support of an appeal		121	280	221	140	Request for oral hearing		138	1,510	138	1,510	Petition to institute a public use proceeding		140	110	240	55	Petition to revive - unavoidable		141	1,280	241	640	Petition to revive - unintentional		142	1,280	242	640	Utility issue fee (or reissue)		143	460	243	230	Design issue fee		144	620	244	310	Plant issue fee		122	130	122	130	Petitions to the Commissioner		123	50	123	50	Processing fee under 37 CFR 1.17(q)		126	180	126	180	Submission of Information Disclosure Stmt		581	40	581	40	Recording each patent assignment per property (times number of properties)		146	740	246	370	Filing a submission after final rejection (37 CFR § 1.129(a))		149	740	249	370	For each additional invention to be examined (37 CFR § 1.129(b))		179	740	279	370	Request for Continued Examination (RCE)		169	900	169	900	Request for expedited examination of a design application		Other fee (specify) _____					<b>SUBTOTAL (3) (\$)</b>				<b>130.00</b>
Fee Code	Large Entity (\$)	Small Entity (\$)	Fee Description	Fee Paid																																																																																																																																																																																						
105	130	205	65	Surcharge - late filing fee or oath	130.00																																																																																																																																																																																					
127	50	227	25	Surcharge - late provisional filing fee or cover sheet																																																																																																																																																																																						
139	130	139	130	Non-English specification																																																																																																																																																																																						
147	2,520	147	2,520	For filing a request for <i>ex parte</i> reexamination																																																																																																																																																																																						
112	920*	112	920*	Requesting publication of SIR prior to Examiner action																																																																																																																																																																																						
113	1,840*	113	1,840*	Requesting publication of SIR after Examiner action																																																																																																																																																																																						
115	110	215	55	Extension for reply within first month																																																																																																																																																																																						
116	400	216	200	Extension for reply within second month																																																																																																																																																																																						
117	920	217	460	Extension for reply within third month																																																																																																																																																																																						
118	1,440	218	720	Extension for reply within fourth month																																																																																																																																																																																						
128	1,960	228	980	Extension for reply within fifth month																																																																																																																																																																																						
119	320	219	160	Notice of Appeal																																																																																																																																																																																						
120	320	220	160	Filing a brief in support of an appeal																																																																																																																																																																																						
121	280	221	140	Request for oral hearing																																																																																																																																																																																						
138	1,510	138	1,510	Petition to institute a public use proceeding																																																																																																																																																																																						
140	110	240	55	Petition to revive - unavoidable																																																																																																																																																																																						
141	1,280	241	640	Petition to revive - unintentional																																																																																																																																																																																						
142	1,280	242	640	Utility issue fee (or reissue)																																																																																																																																																																																						
143	460	243	230	Design issue fee																																																																																																																																																																																						
144	620	244	310	Plant issue fee																																																																																																																																																																																						
122	130	122	130	Petitions to the Commissioner																																																																																																																																																																																						
123	50	123	50	Processing fee under 37 CFR 1.17(q)																																																																																																																																																																																						
126	180	126	180	Submission of Information Disclosure Stmt																																																																																																																																																																																						
581	40	581	40	Recording each patent assignment per property (times number of properties)																																																																																																																																																																																						
146	740	246	370	Filing a submission after final rejection (37 CFR § 1.129(a))																																																																																																																																																																																						
149	740	249	370	For each additional invention to be examined (37 CFR § 1.129(b))																																																																																																																																																																																						
179	740	279	370	Request for Continued Examination (RCE)																																																																																																																																																																																						
169	900	169	900	Request for expedited examination of a design application																																																																																																																																																																																						
Other fee (specify) _____																																																																																																																																																																																										
<b>SUBTOTAL (3) (\$)</b>				<b>130.00</b>																																																																																																																																																																																						
<b>FEE CALCULATION</b>																																																																																																																																																																																										
<p>1. <b>BASIC FILING FEE</b></p> <table border="1"> <thead> <tr> <th>Large Entity Code (\$)</th> <th>Small Entity Code (\$)</th> <th>Fee Description</th> <th>Fee Paid</th> </tr> </thead> <tbody> <tr><td>101</td><td>740</td><td>201</td><td>370</td><td>Utility filing fee</td><td></td></tr> <tr><td>106</td><td>330</td><td>206</td><td>165</td><td>Design filing fee</td><td></td></tr> <tr><td>107</td><td>510</td><td>207</td><td>255</td><td>Plant filing fee</td><td></td></tr> <tr><td>108</td><td>740</td><td>208</td><td>370</td><td>Reissue filing fee</td><td></td></tr> <tr><td>114</td><td>160</td><td>214</td><td>80</td><td>Provisional filing fee</td><td></td></tr> <tr><td colspan="3"><b>SUBTOTAL (1) (\$)</b></td><td></td></tr> </tbody> </table>		Large Entity Code (\$)	Small Entity Code (\$)	Fee Description	Fee Paid	101	740	201	370	Utility filing fee		106	330	206	165	Design filing fee		107	510	207	255	Plant filing fee		108	740	208	370	Reissue filing fee		114	160	214	80	Provisional filing fee		<b>SUBTOTAL (1) (\$)</b>																																																																																																																																																						
Large Entity Code (\$)	Small Entity Code (\$)	Fee Description	Fee Paid																																																																																																																																																																																							
101	740	201	370	Utility filing fee																																																																																																																																																																																						
106	330	206	165	Design filing fee																																																																																																																																																																																						
107	510	207	255	Plant filing fee																																																																																																																																																																																						
108	740	208	370	Reissue filing fee																																																																																																																																																																																						
114	160	214	80	Provisional filing fee																																																																																																																																																																																						
<b>SUBTOTAL (1) (\$)</b>																																																																																																																																																																																										
<p>2. <b>EXTRA CLAIM FEES</b></p> <table border="1"> <thead> <tr> <th>Total Claims</th> <th>Extra Claims</th> <th>Fee from below</th> <th>Fee Paid</th> </tr> </thead> <tbody> <tr><td>_____</td><td>-20** = _____ X _____ = _____</td><td></td><td></td></tr> <tr><td>_____</td><td>-3** = _____ X _____ = _____</td><td></td><td></td></tr> <tr><td>_____</td><td>Multiple Dependent</td><td></td><td></td></tr> </tbody> </table> <table border="1"> <thead> <tr> <th>Large Entity Code (\$)</th> <th>Small Entity Code (\$)</th> <th>Fee Description</th> <th>Fee Paid</th> </tr> </thead> <tbody> <tr><td>103</td><td>18</td><td>203</td><td>9</td><td>Claims in excess of 20</td><td></td></tr> <tr><td>102</td><td>84</td><td>202</td><td>42</td><td>Independent claims in excess of 3</td><td></td></tr> <tr><td>104</td><td>280</td><td>204</td><td>140</td><td>Multiple dependent claim, if not paid</td><td></td></tr> <tr><td>109</td><td>84</td><td>209</td><td>42</td><td>** Reissue independent claims over original patent</td><td></td></tr> <tr><td>110</td><td>18</td><td>210</td><td>9</td><td>** Reissue claims in excess of 20 and over original patent</td><td></td></tr> <tr><td colspan="3"><b>SUBTOTAL (2) (\$)</b></td><td></td></tr> </tbody> </table>		Total Claims	Extra Claims	Fee from below	Fee Paid	_____	-20** = _____ X _____ = _____			_____	-3** = _____ X _____ = _____			_____	Multiple Dependent			Large Entity Code (\$)	Small Entity Code (\$)	Fee Description	Fee Paid	103	18	203	9	Claims in excess of 20		102	84	202	42	Independent claims in excess of 3		104	280	204	140	Multiple dependent claim, if not paid		109	84	209	42	** Reissue independent claims over original patent		110	18	210	9	** Reissue claims in excess of 20 and over original patent		<b>SUBTOTAL (2) (\$)</b>																																																																																																																																						
Total Claims	Extra Claims	Fee from below	Fee Paid																																																																																																																																																																																							
_____	-20** = _____ X _____ = _____																																																																																																																																																																																									
_____	-3** = _____ X _____ = _____																																																																																																																																																																																									
_____	Multiple Dependent																																																																																																																																																																																									
Large Entity Code (\$)	Small Entity Code (\$)	Fee Description	Fee Paid																																																																																																																																																																																							
103	18	203	9	Claims in excess of 20																																																																																																																																																																																						
102	84	202	42	Independent claims in excess of 3																																																																																																																																																																																						
104	280	204	140	Multiple dependent claim, if not paid																																																																																																																																																																																						
109	84	209	42	** Reissue independent claims over original patent																																																																																																																																																																																						
110	18	210	9	** Reissue claims in excess of 20 and over original patent																																																																																																																																																																																						
<b>SUBTOTAL (2) (\$)</b>																																																																																																																																																																																										
<p>**or number previously paid, if greater; For Reissues, see above</p>		<p>*Reduced by Basic Filing Fee Paid</p>																																																																																																																																																																																								

<b>SUBMITTED BY</b>		<i>Complete (if applicable)</i>	
Name (Print/Type)	Terry B. McDaniel	Registration No. (Attorney/Agent)	28,444
Signature		Telephone	843-746-8490
		Date	May 9, 2002

**WARNING: Information on this form may become public. Credit card information should not be included on this form. Provide credit card information and authorization on PTO-2038.**

Burden Hour Statement: This form is estimated to take 0.2 hours to complete. Time will vary depending upon the needs of the individual case. Any comments on the amount of time you are required to complete this form should be sent to the Chief Information Officer, U.S. Patent and Trademark Office, Washington, DC 20231. DO NOT SEND FEES OR COMPLETED FORMS TO THIS ADDRESS. SEND TO: Assistant Commissioner for Patents, Washington, DC 20231.

#3

Express Mail No. EP370311229US

PTO/SB/17 (10-01)

Approved for use through 10/31/2002. OMB 0651-0032  
U.S. Patent and Trademark Office; U.S. DEPARTMENT OF COMMERCE

Under the Paperwork Reduction Act of 1995, no persons are required to respond to a collection of information unless it displays a valid OMB control number.

**FEE TRANSMITTAL**  
**for FY 2002**  
Patent fees are subject to annual revision.

**MAILED**  
MAY 09 2002  
U.S. PATENT AND TRADEMARK OFFICE

Complete if Known	
Application Number	10/100,362
Filing Date	03/18/2002
First Named Inventor	L. H. Hiltzik
Examiner Name	
Group Art Unit	
Attorney Docket No.	CHR 2001-79

TOTAL AMOUNT OF PAYMENT (\$) 130.00

**METHOD OF PAYMENT**

1.  The Commissioner is hereby authorized to charge indicated fees and credit any overpayments to:

Deposit Account Number: 23-1160

Deposit Account Name: \_\_\_\_\_

Charge Any Additional Fee Required Under 37 CFR 1.16 and 1.17

Applicant claims small entity status. See 37 CFR 1.27

2.  Payment Enclosed:

Check  Credit card  Money Order  Other

**FEE CALCULATION**

**1. BASIC FILING FEE**

Large Entity Fee Code (\$)	Small Entity Fee Code (\$)	Fee Description	Fee Paid
101 740	201 370	Utility filing fee	
106 330	206 165	Design filing fee	
107 510	207 255	Plant filing fee	
108 740	208 370	Reissue filing fee	
114 160	214 80	Provisional filing fee	

SUBTOTAL (1) (\$) \_\_\_\_\_

**2. EXTRA CLAIM FEES**

Total Claims	Extra Claims	Fee from below	Fee Paid
Independent Claims	-20** = _____	X _____	= _____
Multiple Dependent	-3** = _____	X _____	= _____

Large Entity Fee Code (\$)	Small Entity Fee Code (\$)	Fee Description	Fee Paid
103 18	203 9	Claims in excess of 20	
102 84	202 42	Independent claims in excess of 3	
104 280	204 140	Multiple dependent claim, if not paid	
109 84	209 42	** Reissue independent claims over original patent	
110 18	210 9	** Reissue claims in excess of 20 and over original patent	

SUBTOTAL (2) (\$) \_\_\_\_\_

**3. ADDITIONAL FEES**

Fee Code	Large Entity Fee (\$)	Small Entity Fee Code (\$)	Fee Description	Fee Paid
105 130	205 65		Surcharge - late filing fee or oath	130.00
127 50	227 25		Surcharge - late provisional filing fee or cover sheet	
139 130	139 130		Non-English specification	
147 2,520	147 2,520		For filing a request for <i>ex parte</i> reexamination	
112 920*	112 920*		Requesting publication of SIR prior to Examiner action	
113 1,840*	113 1,840*		Requesting publication of SIR after Examiner action	
115 110	215 55		Extension for reply within first month	
116 400	216 200		Extension for reply within second month	
117 920	217 460		Extension for reply within third month	
118 1,440	218 720		Extension for reply within fourth month	
128 1,960	228 980		Extension for reply within fifth month	
119 320	219 160		Notice of Appeal	
120 320	220 160		Filing a brief in support of an appeal	
121 280	221 140		Request for oral hearing	
138 1,510	138 1,510		Petition to institute a public use proceeding	
140 110	240 55		Petition to revive - unavoidable	
141 1,280	241 640		Petition to revive - unintentional	
142 1,280	242 640		Utility issue fee (or reissue)	
143 460	243 230		Design issue fee	
144 620	244 310		Plant issue fee	
122 130	122 130		Petitions to the Commissioner	
123 50	123 50		Processing fee under 37 CFR 1.17(q)	
126 180	126 180		Submission of Information Disclosure Stmt	
581 40	581 40		Recording each patent assignment per property (times number of properties)	
146 740	246 370		Filing a submission after final rejection (37 CFR § 1.129(a))	
149 740	249 370		For each additional invention to be examined (37 CFR § 1.129(b))	
179 740	279 370		Request for Continued Examination (RCE)	
169 900	169 900		Request for expedited examination of a design application	

Other fee (specify) \_\_\_\_\_

SUBTOTAL (3) (\$) 130.00

**SUBMITTED BY**

Name (Print/Type)	Terry B. McDaniel	Registration No. (Attorney/Agent)	28,444	Telephone	843-746-8490
Signature		Date	May 9, 2002		

**WARNING:** Information on this form may become public. Credit card information should not be included on this form. Provide credit card information and authorization on PTO-2038.

Burden Hour Statement: This form is estimated to take 0.2 hours to complete. Time will vary depending upon the needs of the individual case. Any comments on the amount of time you are required to complete this form should be sent to the Chief Information Officer, U.S. Patent and Trademark Office, Washington, DC 20231. DO NOT SEND FEES OR COMPLETED FORMS TO THIS ADDRESS. SEND TO: Assistant Commissioner for Patents, Washington, DC 20231.



UNITED STATES PATENT AND TRADEMARK OFFICE

COMMISSIONER FOR PATENTS  
 UNITED STATES PATENT AND TRADEMARK OFFICE  
 WASHINGTON, D.C. 20231  
 www.uspto.gov

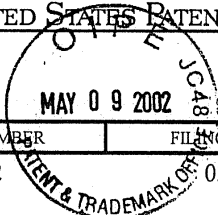

APPLICATION NUMBER	FILING/RECEIPT DATE	FIRST NAMED APPLICANT	ATTORNEY DOCKET NUMBER
10/100,362	03/18/2002	Laurence H. Hiltzik	CHR 2001-79

Westvaco Corporation  
 5255 Virginia Avenue  
 P.O. Box 118005  
 Charleston, SC 29423-8005

CONFIRMATION NO. 3899

FORMALITIES LETTER



\*OC00000007944995\*

Date Mailed: 04/24/2002

**NOTICE TO FILE MISSING PARTS OF NONPROVISIONAL APPLICATION**

FILED UNDER 37 CFR 1.53(b)

*Filing Date Granted*

**Items Required To Avoid Abandonment:**

An application number and filing date have been accorded to this application. The item(s) indicated below, however, are missing. Applicant is given **TWO MONTHS** from the date of this Notice within which to file all required items and pay any fees required below to avoid abandonment. Extensions of time may be obtained by filing a petition accompanied by the extension fee under the provisions of 37 CFR 1.136(a).

- The oath or declaration is missing.  
*A properly signed oath or declaration in compliance with 37 CFR 1.63, identifying the application by the above Application Number and Filing Date, is required.*
- To avoid abandonment, a late filing fee or oath or declaration surcharge as set forth in 37 CFR 1.16(l) of \$130 for a non-small entity, must be submitted with the missing items identified in this letter.

**Items Required To Avoid Processing Delays:**

The item(s) indicated below are also required and should be submitted with any reply to this notice to avoid further processing delays.

**SUMMARY OF FEES DUE:**

Total additional fee(s) required for this application is **\$130** for a Large Entity

- **\$130** Late oath or declaration Surcharge.

*A copy of this notice MUST be returned with the reply.*

05/13/2002 SFELEKEL 00000054 10100362 130.00 00  
 01 FC:105



*Janaye A.*

Customer Service Center  
Initial Patent Examination Division (703) 308-1202

PART 1 - ATTORNEY/APPLICANT COPY

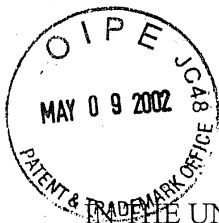

Express Mail No. EF370311229US  
Case Docket No. CHR 2001-79  
Serial No. 10/100,362

Pre  
A 24/A

IN THE UNITED STATES PATENT AND TRADEMARK OFFICE

Applicant: Laurence H. Hiltzik, Jacek Z. Jagiello, Edward D. Tolles, and  
Roger S. Williams

Serial No.: 10/100/362 Group Art Unit: 1754

Filed: March 18, 2002 (with benefit of Provisional Ser. No. 60/335,897)

For: Method for Reducing Emissions from Evaporative Emissions Control System

Examiner:

Assistant Commissioner for Patents  
United States Patent and Trademark Office  
Washington, DC 20231

**PRELIMINARY AMENDMENT**

Dear Sir:

The above-identified application, filed on March 18, 2002, is identical to the Provisional application Serial No. 60/335,897, filed via Express Mail with the U. S. Postal Service on November 21, 2001, with the intent to benefit from the filing date of said provisional application. A cross-reference in the instant application to said provisional application, however, was inadvertently omitted. This preliminary amendment is filed to provide such cross-referencing information.

IN THE SPECIFICATION:

Please amend the specification by adding, at page 1 after the title and before the heading, "BACKGROUND" the language as shown on the following page.

A

Express Mail No. EF370311229US  
Case Docket No. CHR 2001-79  
Serial No. 10/100,362

**Clean Copy of Amended Specification Paragraph**

A This application claims the benefit of U.S. Provisional Application No. 60/335,897 filed  
on November 21, 2001.

Express Mail No.EF370311229US  
Case Docket No. CHR 2001-79  
Serial No. 10/100,362

REMARKS

The reasons for filing this preliminary amendment are stated above. A separate copy of the manner of making the amendment is attached.

If the Examiner believes, for any reason, that personal communication will expedite the prosecution of this application, the Examiner is invited to telephone the undersigned at the number provided.

It is believed that no additional fees are due as a result of this preliminary amendment. If it is determined, however, that any additional fees are required, payment will be remitted upon receipt of the appropriate notification.

Respectfully submitted,

  
Terry H. McDaniel  
Attorney for the Applicant  
Registration No. 28,444

Attachment

Date: May 9, 2002  
5255 Virginia Avenue  
Post Office Box 118005  
Charleston, SC 29423-8005  
Telephone (843) 746-8490

Express Mail No.EF370311229US  
Case Docket No. CHR 2001-79  
Serial No. 10/100,362

**Version with markings to show changes made to amended Specification**

Please amend the heading at page 1 of the application as follows:

“IN THE UNITED STATES PATENT AND TRADEMARK OFFICE

**Patent Application for**

**Method for Reducing Emissions  
from Evaporative Emissions Control Systems**

This application claims the benefit of U.S. Provisional Application No. 60/335,897 filed on November 21, 2001.

*BACKGROUND OF THE INVENTION*”

Sent By: CTC;

8437468494;

Aug-14-02 1:45PM;

Page 1

**MeadWestvaco**

**Facsimile**

#5

MeadWestvaco Corporation  
Charleston Technical Center -- Law Dept.  
5255 Virginia Avenue  
P. O. Box 118005  
Charleston, SC 29423-8005

---

DATE: August 14, 2002

TO: Dominique Bataile  
COMPANY: USPTO  
FAX #: 1-703-305-1086

FROM: Susan Harrison  
SENDER'S PHONE #: (843) 746-8493  
SENDER'S FAX #: (843) 746-8494

SUBJECT: Application No. 10/100,362 filed 3/18/02  
Our Case Docket No. CHR 2001-79

---

TOTAL NUMBER OF PAGES: 10 (including cover sheet)

COMMENTS:

As per our conversation of today, I am submitting the following documents for your kind attention.

- Postcard stamped 5/9/02
- Certificate of Mailing dated 5/9/02
- Combined Declaration, Power of Attorney and Petition in Original Application
- Petition to Make Special under 37 CFR 1.102(c) for Restoration or Maintenance of Environmental Quality (MPEP 708.02, V)
- Declaration in Support of Petition to Make Special

I appreciate your assistance in this matter. Should you require any further information, please do not hesitate to contact me.

---

*This entire transmission is intended only for the use of the individual or entity to which it is addressed and may contain information that is privileged, confidential, and exempt from disclosure under applicable law. If the reader of this message is not intended recipient, or the employee or agent responsible for delivering the message of the intended recipient, you are hereby notified that any dissemination, distribution, or copying of this communication is strictly prohibited. If you have received this communication in error, please notify us immediately by telephone and return the original message to us at the above address via the U.S. Postal Service. You will be reimbursed for all reasonable expenses.*

Sent By: CTC;

8437468494;

Aug-14-02 1:45PM;

Page 2

Express Mail No. EF370311229US  
Case Docket No. CHR 2001-79  
Applicants: L. H. Hiltzik, J. Z. Cadiello, E. D. Tolles,  
and R. S. Williams  
Serial No. 10/100,362  
Filed: March 18, 2002  
For: Method for Reducing Emissions from Evaporative  
Emissions Control System  
Transmittal Form; Fee Transmittal Form duplicate; check  
in the amount of \$130.00; Notice to File Missing Parts;  
Combined Declaration, Power of Attorney and Petition in  
Original Application; Preliminary Amendment; Petition to  
Make Special under 37 CFR 1.102(c) and Declaration in Support;  
Certificate of Mailings for Transmittal Form and Notice to  
File Missing Parts; and one return postcard for the above-  
identified patent application were received in the U.S.  
Patent and Trademark Office on:

Sent By: CTC;

8437468494;

Aug-14-02 1:45PM;

Page 3

EXPRESS MAIL NO. EF37031122/US

Case Docket No. CHR 01-79

Serial No.: 10/100,362

File Date: 3/18/02

CERTIFICATE UNDER 37 C.F.R. 1.10(a)

I hereby certify that this correspondence is being deposited with the United States  
Postal Service as Express Mail in an envelope addressed to the Assistant Commissioner for  
Patents, Washington, DC 20231, on May 9, 2002.

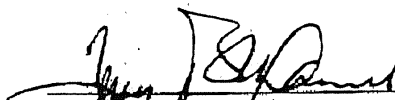

Terry B. McDaniel  
Attorney for the Applicants  
Registration No. 28,444



Express Mail No. EF370311229US

Case Docket No. CHR 2001-79

U. S. Serial (Non-Provisional) No. 10/100,362

**COMBINED DECLARATION, POWER OF ATTORNEY,  
AND PETITION IN ORIGINAL APPLICATION**

As a below named inventor, I hereby declare that:

My residence, post office address and citizenship are as stated below next to my name; that

I verily believe that I am an original first and joint inventor of the subject matter that is claimed, and for which a patent is sought on the invention entitled **Method for Reducing Emissions from Evaporative Emissions Control Systems** described and claimed in the specification, that I hereby state that I have reviewed and understand the contents of the specification, including the claims;

**That I hereby claim the benefit under 35 U.S.C. 119(e) of the United States Provisional Application Serial No. 60/335,897, filed November 21, 2001;**

That I do not know and do not believe that this invention was ever known or used in the United States before my or our invention thereof, or patented or described in any printed publication in any country before my or our invention thereof for more than one year prior to this application, or in public use or on sale in the United States more than one year prior to this application, that this invention has not been patented or made the subject of an inventor's certificate in any country foreign to the United States prior to the date of this application on an application filed by me or my legal representatives or assigns more than twelve months before this application, that I acknowledge my duty to disclose information of which I am aware, which is material to patentability as defined in 37 Code of Federal Regulations § 1.56, and which is material to the examination of this application, namely, information where there is a substantial likelihood that a reasonable Examiner would consider it important in deciding whether to allow the application to issue as a patent; and that no application for patent or inventor's certificate on this invention has been filed by me or my representatives or assigns in any country foreign to the United States.

And I hereby appoint --

Terry B. McDaniel  
Registration No. 28,444  
MeadWestvaco Corporation  
5255 Virginia Avenue  
Post Office Box 118005  
Charleston, South Carolina 29423-8005  
**(WITH WHOM CORRESPONDENCE IS TO BE DIRECTED)**

Express Mail No. EF370311229US

Case Docket No. CHR 2001-79

U. S. Serial (Non-Provisional) No. 10/100,362

and Daniel B. Reece, IV, Registration No. 33,998, MeadWestvaco Corporation, 5255 Virginia Avenue, Post Office Box 118005, Charleston, South Carolina 29423-8005, and each of them, my attorneys, with full powers of substitution and revocation, to prosecute this application and to transact all business in the Patent and Trademark Office connected therewith. I further recognize and acknowledge that the true party in interest of the invention described and claimed herein is the assignee, Westvaco Corporation.

Wherefore I pray that Letters Patent be granted to us for the invention or discovery described and claimed in the foregoing specification and claims, and I hereby subscribe my name to the foregoing specification and claims, declaration, power of attorney, and this petition.

I, the undersigned petitioner, declare further that all statements made herein of my own knowledge are true and all statements made on information and belief are believed to be true; and further that these statements were made with the knowledge that willful false statements and the like so made are punishable by fine or imprisonment, or both, under Section 1001 of Title 18 of the United States Code and that such willful false statements may jeopardize the validity of the application or any patent issuing thereon.

Laurence H. Hiltzik  3/26/02  
FULL NAME OF SOLE OR FIRST INVENTOR INVENTOR'S SIGNATURE DATE

191 Broad Street, Charleston, SC 29401 United States  
RESIDENCE CITIZENSHIP

191 Broad Street, Charleston, SC 29401  
POST OFFICE ADDRESS

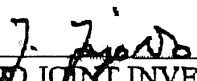
Jacek Z. Jagiello  3/26/02  
FULL NAME OF SECOND JOINT INVENTOR INVENTOR'S SIGNATURE DATE

6240 Old Point Road., Apt. # 41, Charleston, SC 29406 United States  
RESIDENCE CITIZENSHIP

6240 Old Point Road., Apt. # 41, Charleston, SC 29406  
POST OFFICE ADDRESS

Sent By: CTC;

8437468494;

Aug-14-02 1:46PM;

Page 6/10

Express Mail No. EF370311229US

Case Docket No. CHR 2001-79

U. S. Serial (Non-Provisional) No. 10/100,362

Edward D. Tolles

FULL NAME OF THIRD JOINT INVENTOR

Edward D. Tolles INVENTOR'S SIGNATURE

3/26/02 DATE

2 Lampton Road, Charleston, SC 29407

RESIDENCE

United States

CITIZENSHIP

2 Lampton Road, Charleston, SC 29407

POST OFFICE ADDRESS

Roger S. Williams

FULL NAME OF FOURTH JOINT INVENTOR

Roger S. Williams INVENTOR'S SIGNATURE

3/28/02 DATE

900 Boyer Lane, Lexington, VA 24450

RESIDENCE

United States

CITIZENSHIP

900 Boyer Lane, Lexington, VA 24450

POST OFFICE ADDRESS

Sent By: CTC;

8437468494;

Aug-14-02 1:46PM;

Page 7/10

Copy #5

Case Docket No. CHR 2001-79

**IN THE UNITED STATES PATENT AND TRADEMARK OFFICE**

In re Application of: Laurence H. Hiltzik, Jacek Z. Jagiello, Edward D. Tolles, and Roger S. Williams

Provisional Filed: November 21, 2001  
Statutory Filed: March 18, 2002 (referencing benefit of Provisional filing date)

Provisional Serial No. 60/335,897  
Serial No.: 10/100,362

For: "Method for Reducing Emissions from Evaporative Emissions Control Systems"

Examiner:

Assistant Commissioner for Patents  
U. S. Patent and Trademark Office  
Washington, D. C. 20231

**PETITION TO MAKE SPECIAL UNDER 37 C.F.R. §1.102(c)  
FOR RESTORATION OR MAINTENANCE OF ENVIRONMENTAL QUALITY  
(MPEP §708.02, V)**

Dear Sir:

Applicants hereby petition to make this application special as being for an invention which will materially enhance the quality of the environment of mankind by contributing to the

- (a) \_\_\_ restoration of one of the basic life-sustaining natural elements – air, water, or soil.
- (b) X maintenance of one of the basic life-sustaining natural elements – air, water, or soil.

Case Docket No. CHR 2001-79

**1. Accompanying material**

Accompanying this petition is a declaration by

   applicant

  X   applicants' attorney

explaining how the invention materially contributes to category (a) or (b) set forth above.

**2. Fee**

In accordance with 37 C.F.R. §1.102(c), no fee is required for this petition.

Respectfully submitted,



Terry B. McDaniel  
Attorney for the Applicants  
Registration No. 28,444

May 9, 2002  
5255 Virginia Avenue  
P. O. Box 118005  
Charleston, South Carolina 29423-8005  
tel (843) 746-8490  
fax (843) 746-8494

Case Docket No. CHR 01-79

**IN THE UNITED STATES PATENT AND TRADEMARK OFFICE**

In re Application of: Laurence H. Hiltzik, Jacek Z. Jagiello, Edward D. Tolles, and Roger S. Williams

Provisional Filed: November 21, 2001  
Statutory Filed: March 18, 2002 (referencing benefit of Provisional filing date)

Provisional Serial No. 60/335,897  
Serial No.: 10/100,362

For: "Method for Reducing Emissions from Evaporative Emissions Control Systems"

Examiner:

Assistant Commissioner for Patents  
U. S. Patent and Trademark Office  
Washington, D. C. 20231

**DECLARATION IN SUPPORT OF  
PETITION TO MAKE SPECIAL UNDER 37 C.F.R. § 1.102(c)**

Dear Sir:

I, Terry B. McDaniel, Esq., declare as follows:

(1) I am an attorney-of-record for applicants in the above-identified application and, having drafted the specification and claims thereof, am fully aware of the nature of the invention thereof and of its significance and, on implementation, of its ability to materially enhance the quality of the environment and prevent health hazards (which is a basis for granting a petition to make special under MPEP 708.02, V).

(2) The instant application describes a method for sharply reducing diurnal breathing loss emissions from automotive evaporative emissions control systems by providing multiple layers, or stages, of adsorbents. Evaporation of gasoline from motor vehicle fuel systems is a major potential source of hydrocarbon air pollution. The automotive industry is challenged to design engine components and systems to contain, as much as possible, the almost one billion gallons of gasoline evaporated from fuel systems each year in the United States alone. Such emissions can be controlled by canister systems that employ activated carbon to adsorb and hold the vapor that evaporates. Recently, regulations have been promulgated that require a change in the approach with respect to the way in which vapors must be controlled. Allowable emission levels from canisters would be reduced to such low levels that the primary source of emitted

Case Docket No. CHR 01-79

vapor, the fuel tank, is no longer the regulatory focus, as current conventional evaporative emission control appears to have achieved a high efficiency of removal. Rather, the concern now is actually the hydrocarbon left on the carbon adsorbent itself as a residual "heel" after the regeneration (purge) step. Such emissions typically occur when a vehicle has been parked and subjected to diurnal temperature changes over a period of several days, commonly called "diurnal breathing losses." The invention improved combination of high working capacity carbons on the fuel source-side and preferred lower working capacity adsorbent on the vent-side provides substantially lower diurnal breathing emissions (without a significant loss in working capacity or increase in flow restriction) compared with known adsorbents used in canister configurations for automotive emissions control systems.

I declare further that all statements made herein of my own knowledge are true and that all statements made on information and belief are believed to be true and, further, that these statements were made with the knowledge that willful false statements and the like so made are punishable by fine or imprisonment, or both, under 18 USC § 1001 and that such false statements may jeopardize the validity of this document and the application to which it relates.

Signed at Charleston, South Carolina, this 9th day of May, 2002.



Terry B. McDaniel  
Attorney for the Applicants  
Registration No. 28,444

5255 Virginia Avenue  
P. O. Box 118005  
Charleston, SC 29423-8005  
Tel (843) 746-8490  
Fax (843) 746-8494



UNITED STATES PATENT and TRADEMARK OFFICE

UNDER SECRETARY OF COMMERCE FOR INTELLECTUAL PROPERTY AND  
DIRECTOR OF THE UNITED STATES PATENT AND TRADEMARK OFFICE  
WASHINGTON, D.C. 20231  
WWW.USPTO.GOV

SEP 20 2002

UR  
PAPER NO. 6

In re Application of	:	
Laurence H. Hiltzik et al.	:	DECISION
Serial No. 10/100,362	:	ON
Filed: March 18, 2002	:	PETITION
For: METHOD FOR REDUCING EMISSIONS	:	UNDER 708.02, V
FROM EVAPORATIVE EMISSIONS	:	
CONTROL SYSTEMS	:	

This is in response to the petition filed May 09, 2002, requesting that the above-identified application be granted Special Status under Sections 708.02 (V) of the MPEP and 37 CFR 1.102(c).

The petition has been considered and found to comply with the requirements set forth under the above-noted section. Accordingly the petition is **GRANTED**.

Richard V. Fisher, Director  
Technology Center 1700  
Chemical and Materials Engineering

Westvaco Corporation  
5255 Virginia Avenue  
P.O. Box 118005  
Charleston, SC 29423-8005



QTY	NG	PART NAME	RMKS
3	17	BOLT/NUT	
1	16	SPONGE	
1	15	DIFFUSION PLATE	
2	14	PAD	
1	13	PROTECTOR	
1	12	BAND-PROTECTOR	
1	11	ACTIVATED CARBON	
1	10	CLIP	
1	9	INSFRM -PACK RIG	
1	8	HOSE-DIDL CANI. TO CRY	
1	7	HOSE-CANI. TO DBL CANISTER	
1	6	HOSE-CANI TO VACUUM	
1	5	HOSE-CANI. TO TANK	
1	4	F_TEP ASS'Y - AIR	
1	3	CANISTER CLOSE VALVE	
1	2	UHL CONTROL CANISTER	
1	1	CANISTER	

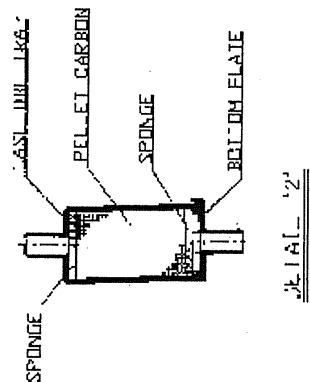
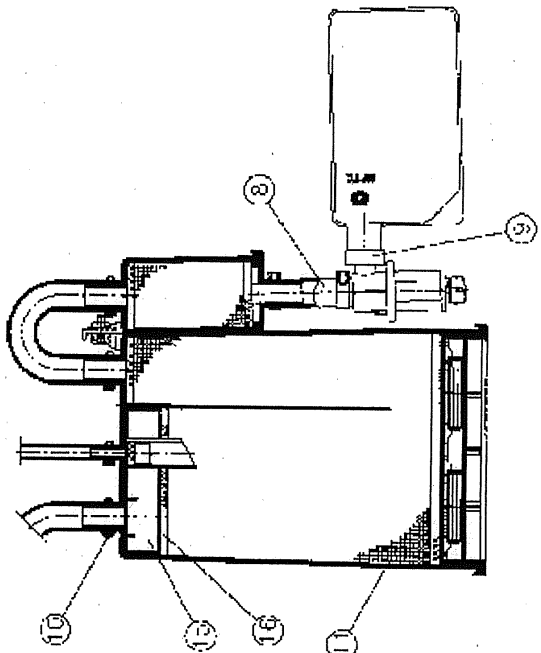
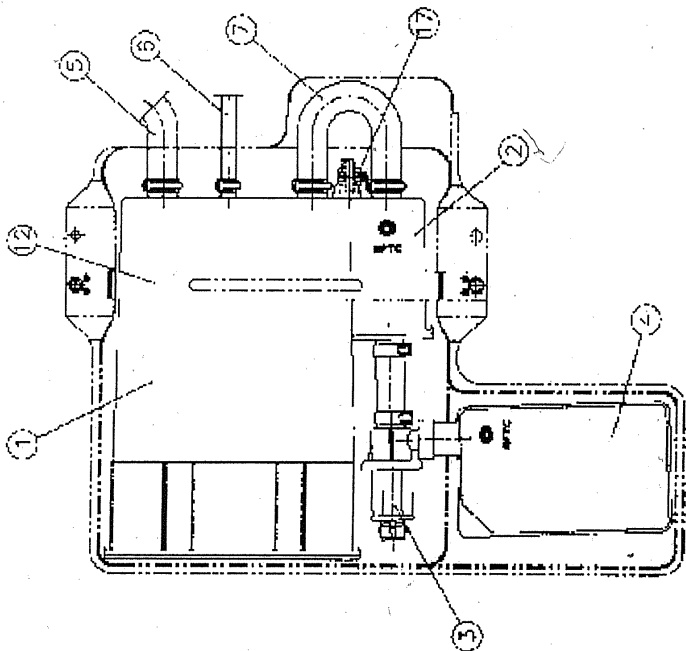
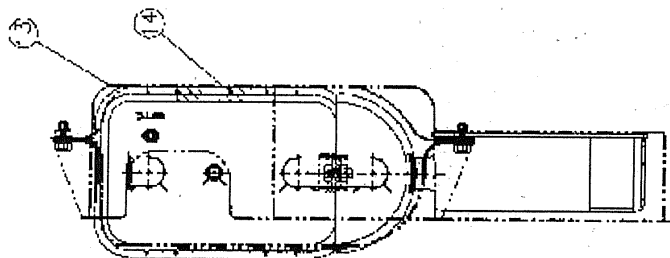

09/23/2002, EAST Version: 1.03.0002



UNITED STATES PATENT AND TRADEMARK OFFICE

UNITED STATES DEPARTMENT OF COMMERCE
United States Patent and Trademark Office
Address: COMMISSIONER OF PATENTS AND TRADEMARKS
Washington, D.C. 20231
www.uspto.gov

NOTICE OF ALLOWANCE AND FEE(S) DUE

7590 10/08/2002
Westvaco Corporation
5255 Virginia Avenue
P.O. Box 118005
Charleston, SC 29423-8005

EXAMINER

LAWRENCE JR, FRANK M

ART UNIT CLASS-SUBCLASS

1724 095-146000

DATE MAILED: 10/08/2002

Table with 5 columns: APPLICATION NO., FILING DATE, FIRST NAMED INVENTOR, ATTORNEY DOCKET NO., CONFIRMATION NO.

TITLE OF INVENTION: METHOD FOR REDUCING EMISSIONS FROM EVAPORATIVE EMISSIONS CONTROL SYSTEMS

Table with 6 columns: APPLN. TYPE, SMALL ENTITY, ISSUE FEE, PUBLICATION FEE, TOTAL FEE(S) DUE, DATE DUE

THE APPLICATION IDENTIFIED ABOVE HAS BEEN EXAMINED AND IS ALLOWED FOR ISSUANCE AS A PATENT. PROSECUTION ON THE MERITS IS CLOSED. THIS NOTICE OF ALLOWANCE IS NOT A GRANT OF PATENT RIGHTS. THIS APPLICATION IS SUBJECT TO WITHDRAWAL FROM ISSUE AT THE INITIATIVE OF THE OFFICE OR UPON PETITION BY THE APPLICANT. SEE 37 CFR 1.313 AND MPEP 1308.

THE ISSUE FEE AND PUBLICATION FEE (IF REQUIRED) MUST BE PAID WITHIN THREE MONTHS FROM THE MAILING DATE OF THIS NOTICE OR THIS APPLICATION SHALL BE REGARDED AS ABANDONED. THIS STATUTORY PERIOD CANNOT BE EXTENDED. SEE 35 U.S.C. 151. THE ISSUE FEE DUE INDICATED ABOVE REFLECTS A CREDIT FOR ANY PREVIOUSLY PAID ISSUE FEE APPLIED IN THIS APPLICATION. THE PTOL-85B (OR AN EQUIVALENT) MUST BE RETURNED WITHIN THIS PERIOD EVEN IF NO FEE IS DUE OR THE APPLICATION WILL BE REGARDED AS ABANDONED.

HOW TO REPLY TO THIS NOTICE:

I. Review the SMALL ENTITY status shown above.

If the SMALL ENTITY is shown as YES, verify your current SMALL ENTITY status:

A. If the status is the same, pay the TOTAL FEE(S) DUE shown above.

B. If the status is changed, pay the PUBLICATION FEE (if required) and twice the amount of the ISSUE FEE shown above and notify the United States Patent and Trademark Office of the change in status, or

If the SMALL ENTITY is shown as NO:

A. Pay TOTAL FEE(S) DUE shown above, or

B. If applicant claimed SMALL ENTITY status before, or is now claiming SMALL ENTITY status, check the box below and enclose the PUBLICATION FEE and 1/2 the ISSUE FEE shown above.

[ ] Applicant claims SMALL ENTITY status. See 37 CFR 1.27.

II. PART B - FEE(S) TRANSMITTAL should be completed and returned to the United States Patent and Trademark Office (USPTO) with your ISSUE FEE and PUBLICATION FEE (if required). Even if the fee(s) have already been paid, Part B - Fee(s) Transmittal should be completed and returned. If you are charging the fee(s) to your deposit account, section "4b" of Part B - Fee(s) Transmittal should be completed and an extra copy of the form should be submitted.

III. All communications regarding this application must give the application number. Please direct all communications prior to issuance to Box ISSUE FEE unless advised to the contrary.

IMPORTANT REMINDER: Utility patents issuing on applications filed on or after Dec. 12, 1980 may require payment of maintenance fees. It is patentee's responsibility to ensure timely payment of maintenance fees when due.

**PART B - FEE(S) TRANSMITTAL**

Complete and send this form, together with applicable fee(s), to: **Mail** Box ISSUE FEE  
**Commissioner for Patents**  
**Washington, D.C. 20231**  
**Fax (703)746-4000**

**INSTRUCTIONS:** This form should be used for transmitting the ISSUE FEE and PUBLICATION FEE (if required). Blocks 1 through 4 should be completed where appropriate. All further correspondence including the Patent, advance orders and notification of maintenance fees will be mailed to the current correspondence address as indicated unless corrected below or directed otherwise in Block 1, by (a) specifying a new correspondence address; and/or (b) indicating a separate "FEE ADDRESS" for maintenance fee notifications.

CURRENT CORRESPONDENCE ADDRESS (Note: Legibly mark-up with any corrections or use Block 1)  
 7590 10/08/2002

Westvaco Corporation  
 5255 Virginia Avenue  
 P.O. Box 118005  
 Charleston, SC 29423-8005

Note: A certificate of mailing can only be used for domestic mailings of the Fee(s) Transmittal. This certificate cannot be used for any other accompanying papers. Each additional paper, such as an assignment or formal drawing, must have its own certificate of mailing or transmission.

**Certificate of Mailing or Transmission**  
 I hereby certify that this Fee(s) Transmittal is being deposited with the United States Postal Service with sufficient postage for first class mail in an envelope addressed to the Box Issue Fee address above, or being facsimile transmitted to the USPTO, on the date indicated below.

(Depositor's name)
(Signature)
(Date)

APPLICATION NO.	FILING DATE	FIRST NAMED INVENTOR	ATTORNEY DOCKET NO.	CONFIRMATION NO.
10/100,362	03/18/2002	Laurence H. Hiltzik	CHR 2001-79	3899

TITLE OF INVENTION: METHOD FOR REDUCING EMISSIONS FROM EVAPORATIVE EMISSIONS CONTROL SYSTEMS

APPLN. TYPE	SMALL ENTITY	ISSUE FEE	PUBLICATION FEE	TOTAL FEE(S) DUE	DATE DUE
nonprovisional	NO	\$1280	\$300	\$1580	01/08/2003

EXAMINER	ART UNIT	CLASS-SUBCLASS
LAWRENCE JR, FRANK M	1724	095-146000

1. Change of correspondence address or indication of "Fee Address" (37 CFR 1.363).

- Change of correspondence address (or Change of Correspondence Address form PTO/SB/122) attached.
- "Fee Address" indication (or "Fee Address" Indication form PTO/SB/47; Rev 03-02 or more recent) attached. Use of a Customer Number is required.

2. For printing on the patent front page, list (1) the names of up to 3 registered patent attorneys or agents OR, alternatively, (2) the name of a single firm (having as a member a registered attorney or agent) and the names of up to 2 registered patent attorneys or agents. If no name is listed, no name will be printed.

1 \_\_\_\_\_  
 2 \_\_\_\_\_  
 3 \_\_\_\_\_

3. ASSIGNEE NAME AND RESIDENCE DATA TO BE PRINTED ON THE PATENT (print or type)

PLEASE NOTE: Unless an assignee is identified below, no assignee data will appear on the patent. Inclusion of assignee data is only appropriate when an assignment has been previously submitted to the USPTO or is being submitted under separate cover. Completion of this form is NOT a substitute for filing an assignment.

(A) NAME OF ASSIGNEE (B) RESIDENCE: (CITY and STATE OR COUNTRY)

Please check the appropriate assignee category or categories (will not be printed on the patent)  individual  corporation or other private group entity  government

4a. The following fee(s) are enclosed:

- Issue Fee
- Publication Fee
- Advance Order - # of Copies \_\_\_\_\_

4b. Payment of Fee(s):

- A check in the amount of the fee(s) is enclosed.
- Payment by credit card. Form PTO-2038 is attached.
- The Commissioner is hereby authorized by charge the required fee(s), or credit any overpayment, to Deposit Account Number \_\_\_\_\_ (enclose an extra copy of this form).

Commissioner for Patents is requested to apply the Issue Fee and Publication Fee (if any) or to re-apply any previously paid issue fee to the application identified above.

(Authorized Signature) (Date)

NOTE: The Issue Fee and Publication Fee (if required) will not be accepted from anyone other than the applicant; a registered attorney or agent; or the assignee or other party in interest as shown by the records of the United States Patent and Trademark Office.

This collection of information is required by 37 CFR 1.311. The information is required to obtain or retain a benefit by the public which is to file (and by the USPTO to process) an application. Confidentiality is governed by 35 U.S.C. 122 and 37 CFR 1.14. This collection is estimated to take 12 minutes to complete, including gathering, preparing, and submitting the completed application form to the USPTO. Time will vary depending upon the individual case. Any comments on the amount of time you require to complete this form and/or suggestions for reducing this burden, should be sent to the Chief Information Officer, U.S. Patent and Trademark Office, U.S. Department of Commerce, Washington, D.C. 20231. DO NOT SEND FEES OR COMPLETED FORMS TO THIS ADDRESS. SEND TO: Commissioner for Patents, Washington, DC 20231.

Under the Paperwork Reduction Act of 1995, no persons are required to respond to a collection of information unless it displays a valid OMB control number.

TRANSMIT THIS FORM WITH FEE(S)



UNITED STATES PATENT AND TRADEMARK OFFICE

UNITED STATES DEPARTMENT OF COMMERCE  
United States Patent and Trademark Office  
Address: COMMISSIONER OF PATENTS AND TRADEMARKS  
Washington, D.C. 20231  
www.uspto.gov

APPLICATION NO.	FILING DATE	FIRST NAMED INVENTOR	ATTORNEY DOCKET NO.	CONFIRMATION NO.
-----------------	-------------	----------------------	---------------------	------------------

10/100,362	03/18/2002	Laurence H. Hiltzik	CHR 2001-79	3899
------------	------------	---------------------	-------------	------

7590 10/08/2002  
Westvaco Corporation  
5255 Virginia Avenue  
P.O. Box 118005  
Charleston, SC 29423-8005

EXAMINER
----------

LAWRENCE JR, FRANK M

ART UNIT	PAPER NUMBER
----------	--------------

1724

DATE MAILED: 10/08/2002

**Determination of Patent Term Adjustment under 35 U.S.C. 154 (b)**  
(application filed on or after May 29, 2000)

The patent term adjustment to date is 0 days. If the issue fee is paid on the date that is three months after the mailing date of this notice and the patent issues on the Tuesday before the date that is 28 weeks (six and a half months) after the mailing date of this notice, the term adjustment will be 0 days.

If a continued prosecution application (CPA) was filed in the above-identified application, the filing date that determines patent term adjustment is the filing date of the most recent CPA.

Applicant will be able to obtain more detailed information by accessing the Patent Application Information Retrieval (PAIR) system. (<http://pair.uspto.gov>)



UNITED STATES PATENT AND TRADEMARK OFFICE

UNITED STATES DEPARTMENT OF COMMERCE
United States Patent and Trademark Office
Address: COMMISSIONER OF PATENTS AND TRADEMARKS
Washington, D.C. 20231
www.uspto.gov

Table with 5 columns: APPLICATION NO., FILING DATE, FIRST NAMED INVENTOR, ATTORNEY DOCKET NO., CONFIRMATION NO.

10/100,362 03/18/2002 Laurence H. Hiltzik CHR 2001-79 3899

7590 10/08/2002

Westvaco Corporation
5255 Virginia Avenue
P.O. Box 118005
Charleston, SC 29423-8005
UNITED STATES

Table with 1 column: EXAMINER

LAWRENCE JR, FRANK M

Table with 2 columns: ART UNIT, PAPER NUMBER

1724

DATE MAILED: 10/08/2002

Notice of Possible Fee Increase on October 1, 2002

If a reply to a "Notice of Allowance and Fee(s) Due" is filed in the Office on or after October 1, 2002, then the amount due may be higher than that set forth in the "Notice of Allowance and Fee(s) Due" since there may be an increase in fees effective on October 1, 2002. See Revision of Patent and Trademark Fees for Fiscal Year 2003: Notice of Proposed Rulemaking, 67 Fed. Reg. 30634, 30636 (May 7, 2002). Although a change to the amount of the publication fee is not currently proposed for October 2002, if the issue fee or publication fee is to be paid on or after October 1, 2002, applicant should check the USPTO web site for the current fees before submitting the payment. The USPTO Internet address for the fee schedule is: http://www.uspto.gov/main/howtofees.htm.

If the issue fee paid is the amount shown on the "Notice of Allowance and Fee(s) Due," but not the correct amount in view of any fee increase, a "Notice to Pay Balance of Issue Fee" will be mailed to applicant. In order to avoid processing delays associated with mailing of a "Notice to Pay Balance of Issue Fee," if the response to the Notice of Allowance and Fee(s) due form is to be filed on or after October 1, 2002 (or mailed with a certificate of mailing on or after October 1, 2002), the issue fee paid should be the fee that is required at the time the fee is paid. If the issue fee was previously paid, and the response to the "Notice of Allowance and Fee(s) Due" includes a request to apply a previously-paid issue fee to the issue fee now due, then the difference between the issue fee amount at the time the response is filed and the previously paid issue fee should be paid. See Manual of Patent Examining Procedure, Section 1308.01 (Eighth Edition, August 2001).

Questions relating to issue and publication fee payments should be directed to the Customer Service Center of the Office of Patent Publication at (703) 305-8283.

TC-7 157

<b>Notice of Allowability</b>	<b>Application No.</b>	<b>Applicant(s)</b>	
	10/100,362	HILTZIK ET AL.	
	<b>Examiner</b>	<b>Art Unit</b>	
	Frank M. Lawrence	1724	

**-- The MAILING DATE of this communication appears on the cover sheet with the correspondence address--**

All claims being allowable, PROSECUTION ON THE MERITS IS (OR REMAINS) CLOSED in this application. If not included herewith (or previously mailed), a Notice of Allowance (PTOL-85) or other appropriate communication will be mailed in due course. **THIS NOTICE OF ALLOWABILITY IS NOT A GRANT OF PATENT RIGHTS.** This application is subject to withdrawal from issue at the initiative of the Office or upon petition by the applicant. See 37 CFR 1.313 and MPEP 1308.

- 1.  This communication is responsive to the application filed March 18, 2002.
- 2.  The allowed claim(s) is/are 1-30.
- 3.  The drawings filed on 18 March 2002 are accepted by the Examiner.
- 4.  Acknowledgment is made of a claim for foreign priority under 35 U.S.C. § 119(a)-(d) or (f).
  - a)  All    b)  Some\*    c)  None    of the:
    - 1.  Certified copies of the priority documents have been received.
    - 2.  Certified copies of the priority documents have been received in Application No. \_\_\_\_\_.
    - 3.  Copies of the certified copies of the priority documents have been received in this national stage application from the International Bureau (PCT Rule 17.2(a)).
  - \* Certified copies not received: \_\_\_\_\_.
- 5.  Acknowledgment is made of a claim for domestic priority under 35 U.S.C. § 119(e) (to a provisional application).
  - (a)  The translation of the foreign language provisional application has been received.
- 6.  Acknowledgment is made of a claim for domestic priority under 35 U.S.C. §§ 120 and/or 121.

Applicant has THREE MONTHS FROM THE "MAILING DATE" of this communication to file a reply complying with the requirements noted below. Failure to timely comply will result in ABANDONMENT of this application. **THIS THREE-MONTH PERIOD IS NOT EXTENDABLE.**

- 7.  A SUBSTITUTE OATH OR DECLARATION must be submitted. Note the attached EXAMINER'S AMENDMENT or NOTICE OF INFORMAL PATENT APPLICATION (PTO-152) which gives reason(s) why the oath or declaration is deficient.
- 8.  CORRECTED DRAWINGS must be submitted.
  - (a)  including changes required by the Notice of Draftsperson's Patent Drawing Review ( PTO-948) attached
    - 1)  hereto or 2)  to Paper No. \_\_\_\_\_.
  - (b)  including changes required by the proposed drawing correction filed \_\_\_\_\_, which has been approved by the Examiner.
  - (c)  including changes required by the attached Examiner's Amendment / Comment or in the Office action of Paper No. \_\_\_\_\_.

**Identifying indicia such as the application number (see 37 CFR 1.84(c)) should be written on the drawings in the top margin (not the back) of each sheet. The drawings should be filed as a separate paper with a transmittal letter addressed to the Official Draftsperson.**

- 9.  DEPOSIT OF and/or INFORMATION about the deposit of BIOLOGICAL MATERIAL must be submitted. Note the attached Examiner's comment regarding REQUIREMENT FOR THE DEPOSIT OF BIOLOGICAL MATERIAL.

**Attachment(s)**

- 1  Notice of References Cited (PTO-892)
- 2  Notice of Informal Patent Application (PTO-152)
- 3  Notice of Draftsperson's Patent Drawing Review (PTO-948)
- 4  Interview Summary (PTO-413), Paper No. \_\_\_\_\_
- 5  Information Disclosure Statements (PTO-1449), Paper No. \_\_\_\_\_
- 6  Examiner's Amendment/Comment
- 7  Examiner's Comment Regarding Requirement for Deposit of Biological Material
- 8  Examiner's Statement of Reasons for Allowance
- 9  Other

**DETAILED ACTION**

*Allowable Subject Matter*

1. Claims 1-30 are allowed.
2. The following is an examiner's statement of reasons for allowance: A method for reducing fuel vapor emissions in automotive evaporative emissions control systems, comprising contacting the fuel vapor with an initial adsorbent volume having incremental adsorption capacity at 25° C of greater than 35 g n-butane/L between vapor concentrations of 5 vol% and 50 vol% n-butane and at least one subsequent adsorbent volume having an incremental adsorption capacity of less than 35 g n-butane/L between vapor concentrations of 5 vol% and 50 vol% n-butane, is not taught, disclosed or suggested in a single reference or a combination of references in the prior art of record. The closest prior art discloses evaporative emission prevention systems comprising different sorbents for reducing diurnal breathing but fails to suggest using sorbents having the butane working capacities specified above. Note that a "PRIOR ART" label has been added to figure 1 because only that which is known is depicted.

Any comments considered necessary by applicant must be submitted no later than the payment of the issue fee and, to avoid processing delays, should preferably accompany the issue fee. Such submissions should be clearly labeled "Comments on Statement of Reasons for Allowance."

*Conclusion*

3. The prior art made of record and not relied upon is considered pertinent to applicant's disclosure. The additional references listed on the attached PTO-892 form, including those listed

Application/Control Number: 10/100,362  
Art Unit: 1724

Page 3

in the instant specification, disclose prepared sorbent materials and evaporative emission systems having different sorbent chambers.

Any inquiry concerning this communication or earlier communications from the examiner should be directed to Frank M. Lawrence whose telephone number is 703-305-0585. The examiner can normally be reached on Mon-Thurs 7:30-5:00; alternate Fridays 7:00-4:00.

If attempts to reach the examiner by telephone are unsuccessful, the examiner's supervisor, David A. Simmons can be reached on 703-308-1972. The fax phone numbers for the organization where this application or proceeding is assigned are 703-872-9310 for regular communications and 703-872-9311 for After Final communications.

Any inquiry of a general nature or relating to the status of this application or proceeding should be directed to the receptionist whose telephone number is 703-308-0651.

fl *fl*  
September 24, 2002

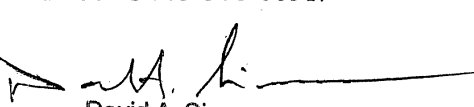
  
David A. Simmons  
Supervisory Patent Examiner  
Technology Center 1700



<b>Notice of References Cited</b>	Application/Control No. 10/100,362	Applicant(s)/Patent Under Reexamination HILTZIK ET AL.	
	Examiner Frank M. Lawrence	Art Unit 1724	Page 1 of 3

**U.S. PATENT DOCUMENTS**

*		Document Number Country Code-Number-Kind Code	Date MM-YYYY	Name	Classification
*	A	US-5,207,808	05-1993	Haruta et al.	123/519
*	B	US-5,337,721	08-1994	Kasuya et al.	123/519
*	C	US-5,408,976	04-1995	Reddy, Sam R.	123/198D
*	D	US-5,456,236	10-1995	Wakashiro et al.	123/519
*	E	US-5,564,398	10-1996	Maeda et al.	123/519
*	F	US-5,914,457	06-1999	Itakura et al.	123/519
*	G	US-6,136,075	10-2000	Bragg et al.	55/519
*	H	US-6,279,548	08-2001	Reddy, Sam Raghuma	123/519
*	I	US-4,677,086	06-1987	McCue et al.	123/519
*	J	US-5,204,310	04-1993	Tolles et al.	123/519
*	K	US-5,206,207	04-1993	Tolles, Edward D.	502/423
*	L	US-5,250,491	10-1993	Yan, Zhiquan Q.	264/117
*	M	US-5,276,000	01-1994	Matthews et al.	502/424

**FOREIGN PATENT DOCUMENTS**

*		Document Number Country Code-Number-Kind Code	Date MM-YYYY	Country	Name	Classification
	N	KR 2002012826 A /	02-2002	Korea	--	--
	O					
	P					
	Q					
	R					
	S					
	T					

**NON-PATENT DOCUMENTS**

*		Include as applicable: Author, Title Date, Publisher, Edition or Volume, Pertinent Pages)
	U	
	V	
	W	
	X	

\*A copy of this reference is not being furnished with this Office action. (See MPEP § 707.05(a).)  
Dates in MM-YYYY format are publication dates. Classifications may be US or foreign.

DERWENT-ACC-NO: 2002-544937  
DERWENT-WEEK: 200258  
COPYRIGHT 1999 DERWENT INFORMATION LTD

TITLE: Diurnal breathing loss control canister  
module system and constructing  
method thereof

INVENTOR: OH, W S

PATENT-ASSIGNEE: KOREA FUEL TECH CORP[KOFUN]

PRIORITY-DATA: 2000KR-0046045 (August 9, 2000)

PATENT-FAMILY:

PUB-NO	PAGES	PUB-DATE	MAIN-IPC	
KR 2002012826		February 20, 2002		N/A
001		B60K 015/10		

A

APPLICATION-DATA:

PUB-NO	APPL-DESCRIPTOR	APPL-NO
	APPL-DATE	
KR2002012826A	N/A	
2000KR-0046045	August 9, 2000	

INT-CL (IPC): B60K015/10

ABSTRACTED-PUB-NO: KR2002012826A

BASIC-ABSTRACT: NOVELTY - A constructing method of  
a DBL(Diurnal Breathing  
Loss) control canister module system is provided to  
cut down expenses and  
improve fuel efficiency by regulating DBL and  
preventing evaporative gas of  
fuel corresponding to exhaust gas regulation.

DETAILED DESCRIPTION - Hydrocarbon is discharged through a large canister(1), and collected to a DBL control canister(2). Activated carbon is filled in the DBL control canister with the volume of 250-1000CC.

A canister close valve(3) is connected between the DBL control canister and an air filter(4) to detect leakage of gas, and air is purified with the air filter. The DBL control canister is fixed with a bolt and a nut(17), or integrally formed in the large canister to prevent from being separated against impact and vibration. Gas is evaporated with increasing temperature of fuel in a tank, and evaporative gas is adsorbed in activated carbon of the canister. Evaporative hydrocarbon is adsorbed in the activated carbon of the DBL control canister, and burned with recycling to the engine by negative pressure of the engine. Fuel efficiency is improved with regulating exhaust gas.

CHOSEN-DRAWING: Dwg.1/10

TITLE-TERMS:

DIURNAL BREATH LOSS CONTROL CANISTER MODULE SYSTEM  
CONSTRUCTION METHOD

DERWENT-CLASS: Q13

<b>Notice of References Cited</b>	Application/Control No. 10/100,362	Applicant(s)/Patent Under Reexamination HILTZIK ET AL.	
	Examiner Frank M. Lawrence	Art Unit 1724	Page 2 of 3

**U.S. PATENT DOCUMENTS**

*		Document Number Country Code-Number-Kind Code	Date MM-YYYY	Name	Classification
*	A	US-5,304,527	04-1994	Dimitri, Mitchell S.	502/416
*	B	US-5,324,703	06-1994	McCue et al.	502/424
*	C	US-5,416,056	05-1995	Baker, Frederick S.	502/425
*	D	US-5,538,932	07-1996	Yan et al.	502/424
*	E	US-5,691,270	11-1997	Miller, James R.	502/174
*	F	US-5,736,481	04-1998	Miller, James R.	502/174
*	G	US-5,736,485	04-1998	Miller, James R.	502/174
*	H	US-5,863,858	01-1999	Miller et al.	502/180
*	I	US-5,914,294	06-1999	Park et al.	501/100
*	J	US-5,456,237	10-1995	Yamazaki et al.	123/519
*	K	US-6,171,373	01-2001	Park et al.	95/138
*	L	US-6,284,705	09-2001	Park et al.	502/180
*	M	US-5,456,236	10-1995	Wakashiro et al.	123/519

**FOREIGN PATENT DOCUMENTS**

*		Document Number Country Code-Number-Kind Code	Date MM-YYYY	Country	Name	Classification
	N					
	O					
	P					
	Q					
	R					
	S					
	T					

**NON-PATENT DOCUMENTS**

*		Include as applicable: Author, Title Date, Publisher, Edition or Volume, Pertinent Pages)
	U	
	V	
	W	
	X	

\*A copy of this reference is not being furnished with this Office action. (See MPEP § 707.05(a).)  
Dates in MM-YYYY format are publication dates. Classifications may be US or foreign.

**Notice of References Cited**

Application/Control No. 10/100,362	Applicant(s)/Patent Under Reexamination HILTZIK ET AL.
Examiner Frank M. Lawrence	Art Unit 1724

**U.S. PATENT DOCUMENTS**

*		Document Number Country Code-Number-Kind Code	Date MM-YYYY	Name	Classification
*	A	US-5,460,136	10-1995	Yamazaki et al.	123/519
*	B	US-5,477,836	12-1995	Hyodo et al.	123/519
*	C	US-4,894,072	01-1990	Turner et al.	123/519
	D	US-			
	E	US-			
	F	US-			
	G	US-			
	H	US-			
	I	US-			
	J	US-			
	K	US-			
	L	US-			
	M	US-			

**FOREIGN PATENT DOCUMENTS**

*		Document Number Country Code-Number-Kind Code	Date MM-YYYY	Country	Name	Classification
	N					
	O					
	P					
	Q					
	R					
	S					
	T					

**NON-PATENT DOCUMENTS**

*		Include as applicable: Author, Title Date, Publisher, Edition or Volume, Pertinent Pages)
	U	
	V	
	W	
	X	

\*A copy of this reference is not being furnished with this Office action. (See MPEP § 707.05(a).)  
Dates in MM-YYYY format are publication dates. Classifications may be US or foreign.



PART B - FEE(S) TRANSMITTAL

Complete and send this form, together with applicable fee(s), to: **Mail** Box ISSUE FEE  
**Commissioner for Patents**  
**Washington, D.C. 20231**  
**Fax** (703)746-4000

INSTRUCTIONS: This form should be used for transmitting the ISSUE FEE and PUBLICATION FEE (if required). Blocks 1 through 4 should be completed where appropriate. All further correspondence including the Patent, advance orders and notification of maintenance fees will be mailed to the current correspondence address as indicated unless corrected below or directed otherwise in Block 1, by (a) specifying a new correspondence address; and/or (b) indicating a separate "FEE ADDRESS" for maintenance fee notifications.

CURRENT CORRESPONDENCE ADDRESS (Note: Legibly mark-up with any corrections or use Block 1)

7590 10/08/2002  
 Westvaco Corporation  
 5255 Virginia Avenue  
 P.O. Box 118005  
 Charleston, SC 29423-8005

Note: A certificate of mailing can only be used for domestic mailings of the Fee(s) Transmittal. This certificate cannot be used for any other accompanying papers. Each additional paper, such as an assignment or formal drawing, must have its own certificate of mailing or transmission.

**Certificate of Mailing or Transmission**  
 I hereby certify that this Fee(s) Transmittal is being deposited with the United States Postal Service with sufficient postage for first class mail in an envelope addressed to the Box Issue Fee address above, or being facsimile transmitted to the USPTO, on the date indicated below.

*Terry B. McDaniel* (Depositor's name)  
 Terry B. McDaniel (Signature)  
 November 14, 2002 (Date)

APPLICATION NO.	FILING DATE	FIRST NAMED INVENTOR	ATTORNEY DOCKET NO.	CONFIRMATION NO.
10/100,362	03/18/2002	Laurence H. Hiltzik	CHR 2001-79	3899

TITLE OF INVENTION: METHOD FOR REDUCING EMISSIONS FROM EVAPORATIVE EMISSIONS CONTROL SYSTEMS

APPLN. TYPE	SMALL ENTITY	ISSUE FEE	PUBLICATION FEE	TOTAL FEE(S) DUE	DATE DUE
nonprovisional	NO	\$1280	\$300	\$1580	01/08/2003

EXAMINER	ART UNIT	CLASS-SUBCLASS
LAWRENCE JR, FRANK M	1724	095-146000

1. Change of correspondence address or indication of "Fee Address" (37 CFR 1.363). \*

- Change of correspondence address (or Change of Correspondence Address upon PTO/SB/122) attached.
- "Fee Address" indication (or "Fee Address" Indication form PTO/SB/47; Rev 03-02 or more recent) attached. Use of a Customer Number is required.

2. For printing on the patent front page, list (1) the names of up to 3 registered patent attorneys or agents OR, alternatively, (2) the name of a single firm (having as a member a registered attorney or agent) and the names of up to 2 registered patent attorneys or agents. If no name is listed, no name will be printed.

- 1 Terry B. McDaniel
- 2 Daniel B. Reece IV
- 3 Richard L. Schmalz

3. ASSIGNEE NAME AND RESIDENCE DATA TO BE PRINTED ON THE PATENT (print or type)

PLEASE NOTE: Unless an assignee is identified below, no assignee data will appear on the patent. Inclusion of assignee data is only appropriate when an assignment has been previously submitted to the USPTO or is being submitted under separate cover. Completion of this form is NOT a substitute for filing an assignment.

(A) NAME OF ASSIGNEE

Westvaco Corporation

(B) RESIDENCE: (CITY AND STATE OR COUNTRY)

Stamford, Connecticut

Please check the appropriate assignee category or categories (will not be printed on the patent)  individual  corporation or other private group entity  government

4a. The following fee(s) are enclosed:

- Issue Fee
- Publication Fee
- Advance Order - # of Copies 10 soft copies

4b. Payment of Fee(s):

- A check in the amount of the fee(s) is enclosed. \$1610.00
- Payment by credit card. Form PTO-2038 is attached.
- The Commissioner is hereby authorized by charge the required fee(s), or credit any overpayment, to Deposit Account Number 23-1160 (enclose an extra copy of this form).

Commissioner for Patents is requested to apply the Issue Fee and Publication Fee (if any) or to re-apply any previously paid issue fee to the application identified above.

(Authorized Signature) *Terry B. McDaniel* (Date) November 14, 2002

NOTE: The Issue Fee and Publication Fee (if required) will not be accepted from anyone other than the applicant, a registered attorney or agent, or the assignee or other party in interest as shown by the records of the United States Patent and Trademark Office.

This collection of information is required by 37 CFR 1.311. The information is required to obtain or retain a benefit by the public which is to file (and by the USPTO to process) an application. Confidentiality is governed by 35 U.S.C. 122 and 37 CFR 1.14. This collection is estimated to take 12 minutes to complete, including gathering, preparing, and submitting the completed application form to the USPTO. Time will vary depending upon the individual case. Any comments on the amount of time you require to complete this form and/or suggestions for reducing this burden, should be sent to the Chief Information Officer, U.S. Patent and Trademark Office, U.S. Department of Commerce, Washington, D.C. 20231. DO NOT SEND FEES OR COMPLETED FORMS TO THIS ADDRESS. SEND TO: Commissioner for Patents, Washington, DC 20231.

Under the Paperwork Reduction Act of 1995, no persons are required to respond to a collection of information unless it displays a valid OMB control number.

11/21/2002 RHEBRAH1 0000091 10100362

01 FC:1501 1280.00 DP  
 02 FC:1504 300.00 DP  
 03 FC:8001 30.00 DP

TRANSMIT THIS FORM WITH FEE(S)

PTOL-85 (REV. 04-02) Approved for use through 01/31/2004. OMB 0651-0033

U.S. Patent and Trademark Office; U.S. DEPARTMENT OF COMMERCE

Sent By: CTC;

8437468494;

Dec-10-02 4:36PM;

Page 1

Case Docket No. CHR 2001-79  
Serial No. 10/100,362

Certificate of Transmission under 37 CFR 1.8

I hereby certify that this correspondence is being facsimile transmitted to the United States Patent and Trademark Office

On December 10, 2002.  
Date

~~Match & Return~~

91

Terry B. McDaniel  
Attorney for the Applicants  
Registration No. 28,444

Typed or printed name of person signing Certificate

Note: Each paper must have its own certificate of transmission, or this certificate must identify each submitted paper.

Fee Transmittal Form PTO/SB/17  
Petition to Withdraw from Issue Under 37 CFR 1.313 (c)(2)  
Declaration in Support of Petition  
Request for Continued Examination (RCE) Transmittal form  
Information Disclosure Statement  
PTO-1449  
Copies of Cited Art

Total 140 pages

RECEIVED  
JAN 27 2003  
TC 1700

FAX RECEIVED  
DEC 11 2002  
GROUP 1700

Received from <8437468494> at 12/10/02 4:36:38 PM [Eastern Standard Time]

Sent By: CTC;

8437468494;

Dec-10-02 4:37PM;

Page 3

Case Docket No. CHR 2001-79

**IN THE UNITED STATES PATENT AND TRADEMARK OFFICE**

In re Application of: L. H. Hiltzik, J. Z. Jagiello, E. D. Tolles, R. S. Williams

Filed: March 18, 2002 Group Art Unit: 1724

Serial No.: 10/100,362

For: "Method For Reducing Emissions From Evaporative Emission Control Systems"

Examiner: Frank M. Lawrence

Assistant Commissioner for Patents  
U. S. Patent and Trademark Office  
Washington, D. C. 20231

**PETITION FOR WITHDRAWAL FROM ISSUE UNDER 37 C.F.R. §1.313(c)(2)**

Dear Sir:

Applicants hereby petition to have the above-described patent application withdrawn from issue under 37 C.F.R. §1.313(c)(2).

**1. Accompanying material**

Accompanying this petition is a declaration by

   applicant

  X   applicants' attorney

showing good and sufficient reasons why withdrawal of the application from issue is necessary.

**FAX RECEIVED**  
DEC 11 2002  
GROUP 1700

Received from <8437468494> at 12/10/02 4:36:38 PM [Eastern Standard Time]



Sent By: CTC;

8437468494;

Dec-10-02 4:37PM;

Page 4

Case Docket No. CHR 2001-79  
Serial No. 10/100,362

**2. Fee**

In accordance with 37 C.F.R. §1.313, the fee set forth in 37 C.F.R. §1.17(h) is hereby submitted with this petition, as permission to authorize a charge to Deposit Account 23-1160.

Respectfully submitted,



Terry E. McDaniel  
Attorney for the Applicants  
Registration No. 28,444

Attachments  
December 10, 2002  
5525 Virginia Avenue  
P. O. Box 118005  
Charleston, South Carolina 29423-8005  
Phone (843) 740-2311  
FAX (843) 740-2335

Case Docket No. CHR 2001-79

**IN THE UNITED STATES PATENT AND TRADEMARK OFFICE**

In re Application of: L. H. Hiltzik, J. Z. Jagiello, E. D. Tolles, R. S. Williams

Serial No. 10/100,362

Filed: March 18, 2002

For: "Method For Reducing Emissions From Evaporative Emission Control Systems"

Examiner: Frank M. Lawrence

Assistant Commissioner for Patents  
 U. S. Patent and Trademark Office  
 Washington, D. C. 20231

**DECLARATION IN SUPPORT OF  
 PETITION TO WITHDRAW FROM ISSUE UNDER 37 C.F.R. § 1.313(c)(2)**

Dear Sir:

I, Terry B. McDaniel, Esq., declare as follows:

(1) I am an attorney-of-record for the applicants in the above-identified application and, having drafted the specification and claims thereof, I am fully aware of the subject matter of the invention thereof and of the field of invention in which it resides. Upon my receipt of the results of the prior art search conducted by the European Patent Office (EPO) in conjunction with the PTC filing based on the instant application, I was made aware for the first time of prior art references that appear to be material and relevant to the examination of the instant application, but have not been examined (which is a basis for this petition to have this application withdrawn from issue under 37 C.F.R. §1.313(c)(2)).

(2) The instant application describes a method for sharply reducing diurnal breathing loss emissions from automotive evaporative emissions canisters by the use of multiple layers, or stages, of adsorbents. On October 8, 2002, the Examiner mailed the notice of allowance of claims 1-30 responsive to the filing of the instant application. The issue fee was timely paid on November 11, 2002. To date, the application has not issued as a U.S. Patent.

In view of the facts set forth, the undersigned attorney-of-record in this application petitions for withdrawal of the application from issue for consideration of a request for continued examination in compliance with 37 C.F.R. §1.114(c). An Information Disclosure Statement

**FAX RECEIVED**  
**DEC 11 2002**  
**GROUP 1700**

Sent By: CTC;

8437468494;

Dec-10-02 4:37PM;

Page 6

Case Docket No. CHR 2001-79

listing the newly discovered references, with some discussion to distinguish from the invention disclosed and claimed in the instant application, is also enclosed for consideration.

I declare further that all statements made herein of my own knowledge are true and that all statements made on information and belief are believed to be true and, further, that these statements were made with the knowledge that willful false statements and the like so made are punishable by fine or imprisonment, or both, under 18 USC § 1001 and that such false statements may jeopardize the validity of this document and the application to which it relates.

Signed at Charleston, South Carolina, this 10th day of December, 2002.

  
Terry H. McDaniel  
Attorney for the Applicants  
Registration No. 28,444

Enclosure

5255 Virginia Avenue  
P. O. Box 118005  
Charleston, SC 29423-8005  
Tel (843) 740-2311  
Fax (843) 740-2335

Received from <8437468494> at 12/10/02 4:36:38 PM [Eastern Standard Time]

<p><b>REQUEST FOR CONTINUED EXAMINATION (RCE) TRANSMITTAL</b> 35 USC 132(b) effective May 29, 2000</p>	<table border="1" style="width: 100%; border-collapse: collapse;"> <tr> <td>Serial No:</td> <td>10/100,362</td> </tr> <tr> <td>Filing Date:</td> <td>March 18, 2001</td> </tr> <tr> <td>First Named Inventor:</td> <td>L. H. Hiltzik</td> </tr> <tr> <td>Group Art Unit:</td> <td>1724</td> </tr> <tr> <td>Examiner:</td> <td>F. M. Lawrence Jr.</td> </tr> <tr> <td>Attorney Docket No:</td> <td>CHR 2001-79</td> </tr> </table>	Serial No:	10/100,362	Filing Date:	March 18, 2001	First Named Inventor:	L. H. Hiltzik	Group Art Unit:	1724	Examiner:	F. M. Lawrence Jr.	Attorney Docket No:	CHR 2001-79
Serial No:	10/100,362												
Filing Date:	March 18, 2001												
First Named Inventor:	L. H. Hiltzik												
Group Art Unit:	1724												
Examiner:	F. M. Lawrence Jr.												
Attorney Docket No:	CHR 2001-79												
<p>This is a Request for Continued Examination (RCE) under 37 C.F.R. § 1.114 for the above identified application.</p>													
<p><b>1. Submission required under 37 C.F.R. § 1.114</b></p> <p>a. <input type="checkbox"/> Previously submitted</p> <p style="margin-left: 20px;">i. <input type="checkbox"/> Consider the amendment(s)/reply under 37 C.F.R. § 1.16 filed on</p> <p style="margin-left: 20px;">ii. <input type="checkbox"/> Consider the arguments in the Appeal Brief/Reply Brief filed on</p> <p style="margin-left: 20px;">iii. <input type="checkbox"/> Other:</p> <p>b. <input checked="" type="checkbox"/> Enclosed</p> <p style="margin-left: 20px;">i. <input type="checkbox"/> Amendment/Reply</p> <p style="margin-left: 20px;">ii. <input checked="" type="checkbox"/> Affidavit(s)/<u>Declaration(s)</u> in support of Petition to Withdraw From Issue</p> <p style="margin-left: 20px;">iii. <input checked="" type="checkbox"/> Information Disclosure Statement (IDS) PTO-1449 and copies of references</p> <p style="margin-left: 20px;">iv. <input checked="" type="checkbox"/> Other: Petition to Withdraw from Issue</p>													
<p><b>2. Miscellaneous</b></p> <p>a. <input type="checkbox"/> Suspension of action on the above-identified application is requested under 37 C.F.R. § 1.103(c) for a period of _____ months. (Period of suspension shall not exceed 3 months; fee under 37 C.F.R. § 1.17(i) required.)</p> <p>b. <input type="checkbox"/> Other:</p>													
<p><b>3. Fees</b></p> <p>a. <input checked="" type="checkbox"/> The Director is hereby authorized to charge the following fees, or credit any overpayment to <b>Deposit Account No. 23-1160.</b></p> <p style="margin-left: 20px;">i. <input type="checkbox"/> RCE fee required under 37 C.F.R. § 1.17(a).</p> <p style="margin-left: 20px;">ii. <input type="checkbox"/> Extension of time fee (37 C.F.R. § 1.136 and 1.17).</p> <p style="margin-left: 20px;">iii. <input type="checkbox"/> Other:</p> <p>b. <input type="checkbox"/> Check in the amount of \$ _____ is enclosed.</p> <p>c. <input type="checkbox"/> Payment is made by credit card (Form PTO-2038 enclosed).</p> <p>d. <input checked="" type="checkbox"/> Fee Transmittal Form authorizing to charge indicated fees (PTO/SB/17 enclosed)</p>													
<p><b>SIGNATURE OF APPLICANT, ATTORNEY OR AGENT REQUIRED</b></p>													
<p>Name: Terry B. McDaniel</p>	<p>Registration Number: 28,444</p>												
<p>Signature: </p>	<p>Date: December 10, 2002</p>												

FAX RECEIVED  
 DEC 11 2002  
 GROUP 1700

Sent By: CTC;

8437468494;

Dec-10-02 4:38PM;

Page 8

Case Docket No. CHR 2001-79  
Serial No. 10/100,362

IN THE UNITED STATES PATENT AND TRADEMARK OFFICE

Applicant: L. H. Hiltzik, J. Z. Jagiello, E. D. Tolles, R. S. Williams  
Serial No.: 10/100,362 Group Art Unit: 1724  
Filed: 03/18/02  
For: Method For Reducing Emissions From Evaporative Emission Control Systems  
Examiner: Frank M. Lawrence Jr.

Honorable Commissioner of  
Patents and Trademarks  
Washington, DC 20231

INFORMATION DISCLOSURE STATEMENT

Dear Sir:

Under the provisions of 37 C.F.R. §§ 1.56, 1.97, and 1.98, applicant submits herewith copies of publication that the Office may wish to consider in continued examination of the subject application. The publications are listed on the attached form PTO-1449.

I hereby certify that each item of information contained in this information disclosure statement was first cited in a communication, dated November 19, 2002, from a foreign patent office in a counterpart foreign application and first came to the attention of the undersigned attorney on December 2, 2002, after being forwarded from the corporate receiving office for such correspondence in Atlanta, GA. The Commissioner is hereby authorized to charge the fee set forth in 37 C.F.R. §1.17 (p) in the amount of \$180.00, which is listed on the enclosed Fee Transmittal form.

Allowability of the claims of the instant application was based on the examiner's finding that "the closest prior art discloses evaporative emission control systems comprising different

1

Received from < 8437468494 > at 12/10/02 4:36:38 PM [Eastern Standard Time]

**FAX RECEIVED**  
DEC 11 2002  
**GROUP 1724**

Case Docket No. CHR 2001-79  
Serial No. 10/100,362

sorbents for reducing diurnal breathing but fails to suggest using sorbents having the (specified) butane working capacities.”

Of the six documents cited in the attached International Search Report, describing canisters with layers or compartments containing different adsorbents or containing heat absorbing or heat generating media, three are considered to define the general state of the art but are “not considered to be of particular relevance.” These are WO 92 01585 A to British Petroleum Co., U.S. Patent No. 5,460,136 to Yamazaki et al., and U.S. Patent No. 6,279,548 to Reddy.

WO 92 01585 A describes the use of two different adsorbents to improve canister working capacity. The first adsorbent is conventional activated carbon, and the second is selected from a group of adsorbent organic polymers. A claimed feature is that purge gas first enters the activated carbon component. The disclosure of the instant application, on the other hand, teaches that for bleed emission control the purge gas must first enter the special adsorbent, not the conventional activated carbon component. The invention claimed is consistent with such teaching, and it is respectfully submitted that there is no suggestion of such invention in WO 92 01585 A.

Yamazaki, et al., in US 5,460,136 A, consider an evaporative emission control system with more than one chamber, which improves adsorption efficiency when the system is used to capture both on-board refueling and other evaporative losses. It is respectfully submitted that this teaching is irrelevant to the invention of the instant application because the patent teaching only concerns canister hardware, not the properties of the adsorbent contained therein.

Reddy, in US 6,279,548 B1, describes a canister having more than one chamber that achieves improved regeneration by heating a volume of adsorbent at the purge inlet. The disclosure of the instant application does not teach heating the adsorbent; therefore, such feature is not claimed by the applicants.

In view of the above descriptions of the cited references, it is apparent that their designation as by the international searching authority “not particularly relevant” is accurate.

The remaining three references cited in the International Search Report, however, were designated to be “of particular relevance.” Therefore, it was deemed that compliance with the disclosure requirements of 37 C.F.R. §§ 1.56, 1.97, and 1.98 required the necessary effort to have the application withdrawn from issue, even though the issue fee had been paid, to request continued examination for their consideration by the examiner in resolving the issue of patentability.

Case Docket No. CHR 2001-79  
Serial No. 10/100,362

The additional cited references include EP 11 13163 to Tennex Corporation, WO 01 62367 to MacDowall et al., and U.S. Patent No. 6,488,748 to Yamafuji et al. (formerly an application published as US 2001-0020418).

The International Search Report also included a copy of the search results for the published application, EP 1,113,163, of Tennex. The document discloses an improvement in "conventional" vapor treatment technology as disclosed by Japanese Patent Provisional Publication No. 9-112356. The document describes a canister that comprises a single compartment with layers of adsorbent and alternate layers of heat accumulative material. The EP application describes a canister containing an adsorbent mixed with a heat absorbing material that has a heat capacity higher than that of the adsorbent, and considers multiple chambers and layer configurations designed to overcome drawbacks of the earlier design. In each of these inventions, canister working capacity is proposed to increase over canisters filled with adsorbent alone because heat produced during uptake of vapor is absorbed to a greater extent, so that the temperature of the adsorbent does not increase as much as it would in the absence of the heat absorbing material. Likewise the temperature would not decrease as much during regeneration. Therefore, more vapors would be picked-up during adsorption and more removed during purge. The EP application contends that this strategy is so effective that engine operation may be disrupted by too much vapor being released during regeneration purge. The object of the EP application is to overcome this drawback by physical arrangement of the different layers of adsorbent and heat absorbing materials, and by particular constructions of the adsorption canister.

The parts of EP 1,113,163 cited as relevant to the instant application are:

Pg 18, Para 64, which describes a honeycomb form of adsorbent incorporating a dispersed mixture of adsorbent, binder, and heat accumulative material. The previous paragraph lists aluminum, aluminum alloy, and ceramic as examples of heat accumulative materials.

Claims 1-6 specify different arrangements of canisters incorporating fuel adsorbing and heat accumulative materials, wherein the heat accumulative material has a heat capacity higher than that of the adsorbent.

Figs 1-7 show different canister configurations and different ways of partitioning fuel adsorbing and heat accumulative materials.

The Tennex application teaches that the working capacity of automotive fuel treatment canisters can be improved by incorporation of heat accumulating materials into the canister or directly into an adsorbent form such as a honeycomb. This is quite different from the object of the invention claimed in the instant application, which is directed more specifically toward control of diurnal bleed emissions from automotive canisters, and on a volume basis, use of the invention actually tends to decrease the working capacity of the canister system. The applicants' disclosure teaches that the canister system should consist of a volume of fuel adsorbing material

Case Docket No. CHR 2001-79  
Serial No. 10/100,362

with high adsorption capacity, and a separate volume of bleed control adsorbent. The bleed control adsorbent preferably has a high adsorption capacity on a mass basis, but is distributed in space so that its volumetric capacity is relatively low according to a claimed range. The distribution in space of the adsorbent can be attained by different means, one of which is dispersion by the addition of diluents and/or binders. However, such dispersing materials are not required to have a heat capacity even as high as the adsorbent itself. The applicants' experiments showed, for example, that when activated carbon was dispersed in a pellet by dilution with glass microbeads, the performance in control of bleed emissions was the same whether the beads were solid, with a relatively high heat capacity, or hollow, with a relatively low heat capacity. Coincidentally, honeycomb forms of activated carbon made by extrusion of a mixture of carbon and clays under our commonly-assigned patent contain components which could contribute to heat absorption, but good performance of honeycomb elements in bleed control is not related to this. A honeycomb element contains so little carbon (in relation to the clay-based material) that heat exchange with purge gas easily offsets the cooling due to desorption during purge, which would be appreciated by one skilled in the art. Furthermore, little heat is generated during the adsorption of bleed emissions because both the vapor concentration and flow rate influent to the honeycomb is very small.

It is respectfully submitted, therefore, that the teaching of published application EP 11 13163 would not suggest, to one skilled in the art, the claimed invention of the instant application.

Maddowall, et al., in WO 01 6267 A, describe a canister system that uses a layered bed consisting of a first layer of conventional activated carbon and a smaller second layer of another adsorbent with faster adsorption kinetics. Optionally, the two layers might be located in separate containers. In either case, the adsorbent with faster kinetics is located to receive first contact with purge air during regeneration. Pelletized activated carbon is cited as an example of conventional adsorbent. Examples of adsorbents with faster kinetics include materials with smaller particle size, or other favorable shape, and materials with a favorable but undefined pore size distribution. The only supporting data concerns use of smaller particle size for the second layer, and the most preferred embodiment of this invention is stated to be characterized by the external particle surface-area-to-volume ratios of the smaller and larger particles in the two layers.

Pg 4, Ln 9-29, noted by the searcher, discusses use of two separate adsorbents, differentiated by adsorption kinetics.

The claimed invention of the instant application does not rely upon adsorption kinetics to obtain desired performance. Required dilution of carbon particles in a matrix of nonadsorbent material would actually be expected to cause slower adsorption kinetics for the some of our



Case Docket No. CHR 2001-79  
Serial No. 10/100,362

claimed embodiments. Thus, a teaching of reliance on adsorption kinetics would not suggest what the applicants did, as defined by the claims of the instant application.

Pg 5, Ln 15-20, also noted by the searcher, states

The amount of adsorbents is selected such that the adsorption capacity in the lower heat capacity section is greater than the capacity in the higher heat capacity section. This generally means that the weight of adsorbent in the lower heat capacity section is greater than the weight of adsorbent in the higher heat capacity section.

This feature of the MacDowall et al. invention is based on the necessity of restricting the increase in pressure drop resulting from use of smaller particles, and on observed improvements in experimental breakthrough performance. It must be noted, however, that the demonstrated improvement was obtained using different particle sizes of the same carbon in the first and second layers. While this clearly supports the kinetic concept exposted by their invention, it is not relevant to the applicants' claimed invention, which teaches the use of different adsorbents with a particular range of equilibrium volumetric capacity in the second layer.

Finally, the searcher noted the "claims" to be somehow relevant. However, the claims of the reference principally concern adsorption rate and particle size of first and second adsorbents. None of which are relevant to our invention, as it places no reliance on kinetics or particle size.

Lastly, Yamafuji et al., in U.S. Patent No. 6,488,748/US 2001/020418 A1, describe a canister system with two or more compartments or layers containing a conventional adsorbent in the first layer, and material with higher heat capacity in the second layer. The higher heat capacity can be produced by selecting a particular adsorbent with a high heat capacity, or by mixing another material with high heat capacity with the adsorbent in this layer. Goals are the same as in the Tennex published application EP 1,113,163.

Attention was called by the searcher to:

Pg 3, paragraphs 44 and 45, which report that the heat capacity of the second layer can be increased by adding particles of materials with higher specific heat and thermal conductivity including alumina, glass, etc., iron, copper, lead, etc.

The applicants' claimed invention may use glass, or clays containing alumina, in a dispersive matrix with carbon to dilute the adsorptive activity of the carbon component, but beneficial properties are in no way based on heat management, and it is coincidental that such materials may also increase heat capacity. It is respectfully submitted that there is no teaching or

Case Docket No. CHR 2001-79  
Serial No. 10/100,362

claimed embodiments. Thus, a teaching of reliance on adsorption kinetics would not suggest what the applicants did, as defined by the claims of the instant application.

Pg 5, Ln 15-20, also noted by the searcher, states

The amount of adsorbents is selected such that the adsorption capacity in the lower heat capacity section is greater than the capacity in the higher heat capacity section. This generally means that the weight of adsorbent in the lower heat capacity section is greater than the weight of adsorbent in the higher heat capacity section.

This feature of the MacDowall et al. invention is based on the necessity of restricting the increase in pressure drop resulting from use of smaller particles, and on observed improvements in experimental breakthrough performance. It must be noted, however, that the demonstrated improvement was obtained using different particle sizes of the same carbon in the first and second layers. While this clearly supports the kinetic concept expounded by their invention, it is not relevant to the applicants' claimed invention, which teaches the use of different adsorbents with a particular range of equilibrium volumetric capacity in the second layer.

Finally, the searcher noted the "claims" to be somehow relevant. However, the claims of the reference principally concern adsorption rate and particle size of first and second adsorbents. None of which are relevant to our invention, as it places no reliance on kinetics or particle size.

Lastly, Yamafuji et al., in U.S. Patent No. 6,488,748/US 2001/020418 A1, describe a canister system with two or more compartments or layers containing a conventional adsorbent in the first layer, and material with higher heat capacity in the second layer. The higher heat capacity can be produced by selecting a particular adsorbent with a high heat capacity, or by mixing another material with high heat capacity with the adsorbent in this layer. Goals are the same as in the Tennex published application EP 1,113,163.

Attention was called by the searcher to:

Pg 3, paragraphs 44 and 45, which report that the heat capacity of the second layer can be increased by adding particles of materials with higher specific heat and thermal conductivity including alumina, glass, etc., iron, copper, lead, etc.

The applicants' claimed invention may use glass, or clays containing alumina, in a dispersive matrix with carbon to dilute the adsorptive activity of the carbon component, but beneficial properties are in no way based on heat management, and it is coincidental that such materials may also increase heat capacity. It is respectfully submitted that there is no teaching or

Case Docket No. CHR 2001-79  
Serial No. 10/100,362

suggestion that the adsorbents disclosed by Yamafuji et al. fall within the specifically defined ranges of adsorption capacity claimed by the applicants.

In his earlier statement of reasons for allowance that resulted in this application's post-issue fee paid status, the Examiner noted that the applicants' claimed "method for reducing fuel vapor emissions in automotive evaporative emissions control systems comprising the steps of contacting the fuel vapor with an initial adsorbent volume having incremental adsorption capacity at 25°C of greater than 35 g n-butane/L between vapor concentrations of 5 vol% and 50 vol% n-butane and at least one subsequent adsorbent volume having an incremental adsorption capacity of less than 35 g n-butane/L between vapor concentrations of 5 vol% and 50 vol% n-butane is not taught, disclosed or suggested in a single reference or a combination of references in the prior art of record." It is respectfully submitted that, having placed the above disclosed and discussed prior art in the record of examination of the instant application, that statement by the examiner remains true. Moreover, the Examiner's further statement that "The closest prior art discloses evaporative emission prevention systems comprising different sorbents for reducing diurnal breathing but fails to suggest using sorbents having the butane working capacities specified above [in applicants' claim 1]." It is respectfully submitted that, having placed the above disclosed and discussed prior art in the record of examination of the instant application, that statement by the examiner also remains true.

Although noted of varying degrees of relevance in an international search report in a foreign application filing based on the instant U.S. application, these citations do not necessarily constitute an admission that the references are relevant or material to the claims; they are cited only as constituting the closest art of which the applicant has recently been made aware.

Respectfully Submitted,

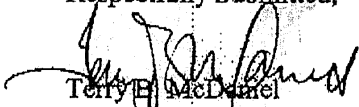
  
Terry E. McDermel  
Attorney for the Applicants  
Registration No. 28,444

Attachments

Dated: December 10, 2002  
5255 Virginia Avenue  
Post Office Box 118005  
Charleston, SC 29423-8005  
(843) 746-8493

COPY

Sheet 1 of 1

<b>Form PTO-1449</b> (REV. 8-83)		U.S. DEPT. OF COMMERCE PATENT AND TRADEMARK OFFICE				Atty. Docket No. CHR 2001-79	SERIAL NO. 10/100,362								
<b>INFORMATION DISCLOSURE CITATION</b> (Use several sheets if necessary)						APPLICANT E.H. Hiltzik, J.Z. Jagiello, E.D. Tolles, and R.S. Williams									
						FILING DATE 03/18/02	GROUP 1725								
U.S. PATENT DOCUMENTS															
*EXAMINER INITIAL	DOCUMENT NUMBER							DATE	NAME	CLASS	SUBCLASS	FILING DATE IF APPROPRIATE			
	5	4	6	0	1	3	6	10/95	Yamazaki et al.						
	6	2	7	9	5	4	8	08/01	Reddy						
	6	4	8	8	7	4	8	12/02	Yamafuji et al. (Publication No. US 2001-0020418 (09/01))						
FOREIGN PATENT DOCUMENTS															
		DOCUMENT NUMBER							DATE	COUNTRY	CLASS	SUBCLASS	TRANSLATION		
													YRS	NO	
		EP	11	1	3	1	6	3	7/01	European Patent Office Publication					
		WO	01	6	2	3	6	7	8/01	PCT Publication					
		WO	92	0	1	5	8	5	9/92	PCT Publication					
OTHER DOCUMENTS (Including Author, Title, Date, Pertinent Pages, Etc.)															
EXAMINER								DATE CONSIDERED							
<small>*EXAMINER: Initial if citation considered, whether or not citation is in conformance with MPEP 609. Draw line through citation if not in conformance and not considered. Include copy of this form with next communication with applicant.</small>															

COPY

PATENT COOPERATION TREATY

From the INTERNATIONAL SEARCHING AUTHORITY

PCT

To:  
 WESTVACO CORPORATION  
 Attn. McDaniel, Terry, B.  
 4850D North Church Lane  
 Smyrna, GA 30080  
 UNITED STATES OF AMERICA

RECEIVED  
 THE MEAD CORPORATION  
 NOV 25 2002  
 LEGAL DEPARTMENT ATLANTA  
 BY \_\_\_\_\_

NOTIFICATION OF TRANSMITTAL OF  
 THE INTERNATIONAL SEARCH REPORT  
 OR THE DECLARATION

(PCT Rule 44.1)

Applicant's or agent's file reference <b>CHR 2001-79</b>	<b>FOR FURTHER ACTION</b> See paragraphs 1 and 4 below
International application No. <b>PCT/US 02/ 21621</b>	International filing date (day/month/year) <b>08/07/2002</b>
Date of mailing (day/month/year) <b>19/11/2002</b>	
Applicant <b>WESTVACO CORPORATION</b>	

- The applicant is hereby notified that the International Search Report has been established and is transmitted herewith.  
**Filing of amendments and statement under Article 19:**  
 The applicant is entitled, if he so wishes, to amend the claims of the International Application (see Rule 46):  
  
**When?** The time limit for filing such amendments is normally 2 months from the date of transmittal of the International Search Report; however, for more details, see the notes on the accompanying sheet.  
  
**Where?** Directly to the International Bureau of WIPO  
 34, chemin des Colombettes  
 1211 Geneva 20, Switzerland  
 Facsimile No.: (41-22) 740.14.35  
  
 For more detailed instructions, see the notes on the accompanying sheet.
- The applicant is hereby notified that no International Search Report will be established and that the declaration under Article 17(2)(a) to that effect is transmitted herewith.
- With regard to the protest against payment of (an) additional fee(s) under Rule 40.2, the applicant is notified that:
  - the protest together with the decision thereon has been transmitted to the International Bureau together with the applicant's request to forward the texts of both the protest and the decision thereon to the designated Offices.
  - no decision has been made yet on the protest; the applicant will be notified as soon as a decision is made.
- 4. Further action(s):** The applicant is reminded of the following:  
  
 Shortly after 16 months from the priority date, the International application will be published by the International Bureau. If the applicant wishes to avoid or postpone publication, a notice of withdrawal of the international application, or of the priority claim, must reach the International Bureau as provided in Rules 90b/s.1 and 90b/s.3, respectively, before the completion of the technical preparations for International publication.  
  
 Within 19 months from the priority date, a demand for international preliminary examination must be filed if the applicant wishes to postpone the entry into the national phase until 30 months from the priority date (in some Offices even later).  
  
 Within 20 months from the priority date, the applicant must perform the prescribed acts for entry into the national phase before all designated Offices which have not been elected in the demand or in a later election within 19 months from the priority date or could not be elected because they are not bound by Chapter II.

Name and mailing address of the International Searching Authority  European Patent Office, P.B. 5818 Patentlaan 2 NL-2280 HV Rijswijk Tel. (+31-70) 340-2040, Tx. 31 661 epo nl, Fax: (+31-70) 340-3016	Authorized officer  <b>Peggy Frenzel</b>
--	--

Form PCT/ISA/220 (July 1998)

Received from <8437468494> at 12/10/02 4:36:38 PM [Eastern Standard Time]

### NOTES TO FORM PCT/ISA/220

These Notes are intended to give the basic instructions concerning the filing of amendments under article 19. The Notes are based on the requirements of the Patent Cooperation Treaty, the Regulations and the Administrative Instructions under that Treaty. In case of discrepancy between these Notes and those requirements, the latter are applicable. For more detailed information, see also the PCT Applicant's Guide, a publication of WIPO.

In these Notes, "Article", "Rule", and "Section" refer to the provisions of the PCT, the PCT Regulations and the PCT Administrative Instructions respectively.

### INSTRUCTIONS CONCERNING AMENDMENTS UNDER ARTICLE 19

The applicant has, after having received the international search report, one opportunity to amend the claims of the international application. It should however be emphasized that, since all parts of the international application (claims, description and drawings) may be amended during the international preliminary examination procedure, there is usually no need to file amendments of the claims under Article 19 except where, e.g. the applicant wants the latter to be published for the purposes of provisional protection or has another reason for amending the claims before international publication. Furthermore, it should be emphasized that provisional protection is available in some States only.

#### What parts of the international application may be amended?

Under Article 19, only the claims may be amended.

During the international phase, the claims may also be amended (or further amended) under Article 34 before the International Preliminary Examining Authority. The description and drawings may only be amended under Article 34 before the International Examining Authority.

Upon entry into the national phase, all parts of the international application may be amended under Article 28 or, where applicable, Article 41.

#### When?

Within 2 months from the date of transmittal of the international search report or 16 months from the priority date, whichever time limit expires later. It should be noted, however, that the amendments will be considered as having been received on time if they are received by the International Bureau after the expiration of the applicable time limit but before the completion of the technical preparations for international publication (Rule 46.1).

#### Where not to file the amendments?

The amendments may only be filed with the International Bureau and not with the receiving Office or the International Searching Authority (Rule 46.2).

Where a demand for international preliminary examination has been/is filed, see below.

#### How?

Either by cancelling one or more entire claims, by adding one or more new claims or by amending the text of one or more of the claims as filed.

A replacement sheet must be submitted for each sheet of the claims which, on account of an amendment or amendments, differs from the sheet originally filed.

All the claims appearing on a replacement sheet must be numbered in Arabic numerals. Where a claim is cancelled, no renumbering of the other claims is required. In all cases where claims are renumbered, they must be renumbered consecutively (Administrative Instructions, Section 205(b)).

The amendments must be made in the language in which the international application is to be published.

#### What documents must/may accompany the amendments?

##### Letter (Section 205(b)):

The amendments must be submitted with a letter.

The letter will not be published with the international application and the amended claims. It should not be confused with the "Statement under Article 19(1)" (see below, under "Statement under Article 19(1)").

The letter must be in English or French, at the choice of the applicant. However, if the language of the international application is English, the letter must be in English; if the language of the international application is French, the letter must be in French.

Notes to Form PCT/ISA/220 (first sheet) (January 1994)

Received from < 8437468494 > at 12/10/02 4:36:38 PM [Eastern Standard Time]

**NOTES TO FORM PCT/ISA/220 (continued)**

The letter must indicate the differences between the claims as filed and the claims as amended. It must, in particular, indicate, in connection with each claim appearing in the international application (it being understood that identical indications concerning several claims may be grouped), whether

- (i) the claim is unchanged;
- (ii) the claim is cancelled;
- (iii) the claim is new;
- (iv) the claim replaces one or more claims as filed;
- (v) the claim is the result of the division of a claim as filed.

The following examples illustrate the manner in which amendments must be explained in the accompanying letter:

1. [Where originally there were 48 claims and after amendment of some claims there are 51]:  
"Claims 1 to 29, 31, 32, 34, 35, 37 to 48 replaced by amended claims bearing the same numbers; claims 30, 33 and 36 unchanged; new claims 49 to 51 added."
2. [Where originally there were 15 claims and after amendment of all claims there are 11]:  
"Claims 1 to 15 replaced by amended claims 1 to 11."
3. [Where originally there were 14 claims and the amendments consist in cancelling some claims and in adding new claims]:  
"Claims 1 to 6 and 14 unchanged; claims 7 to 13 cancelled; new claims 15, 16 and 17 added." or  
"Claims 7 to 13 cancelled; new claims 15, 16 and 17 added; all other claims unchanged."
4. [Where various kinds of amendments are made]:  
"Claims 1-10 unchanged; claims 11 to 13, 18 and 19 cancelled; claims 14, 15 and 16 replaced by amended claim 14; claim 17 subdivided into amended claims 15, 16 and 17; new claims 20 and 21 added."

**"Statement under article 19(1)" (Rule 46.4)**

The amendments may be accompanied by a statement explaining the amendments and indicating any impact that such amendments might have on the description and the drawings (which cannot be amended under Article 19(1)).

The statement will be published with the international application and the amended claims.

It must be in the language in which the international application is to be published.

It must be brief, not exceeding 500 words if in English or if translated into English.

It should not be confused with and does not replace the letter indicating the differences between the claims as filed and as amended. It must be filed on a separate sheet and must be identified as such by a heading, preferably by using the words "Statement under Article 19(1)".

It may not contain any disparaging comments on the international search report or the relevance of citations contained in that report. Reference to citations, relevant to a given claim, contained in the international search report may be made only in connection with an amendment of that claim.

**Consequence if a demand for international preliminary examination has already been filed**

If, at the time of filing any amendments under Article 19, a demand for international preliminary examination has already been submitted, the applicant must preferably, at the same time of filing the amendments with the International Bureau, also file a copy of such amendments with the International Preliminary Examining Authority (see Rule 62.2(a), first sentence).

**Consequence with regard to translation of the international application for entry into the national phase**

The applicant's attention is drawn to the fact that, where upon entry into the national phase, a translation of the claims as amended under Article 19 may have to be furnished to the designated/selected Offices, instead of, or in addition to, the translation of the claims as filed.

For further details on the requirements of each designated/selected Office, see Volume II of the PCT Applicant's Guide.

PATENT COOPERATION TREATY

PCT

INTERNATIONAL SEARCH REPORT

(PCT Article 18 and Rules 43 and 44)

Applicant's or agent's file reference <b>CHR 2001-79</b>	<b>FOR FURTHER ACTION</b> see Notification of Transmittal of International Search Report (Form PCT/ISA/220) as well as, where applicable, item 5 below.	
International application No. <b>PCT/US 02/21621</b>	International filing date (day/month/year) <b>08/07/2002</b>	(Earliest) Priority Date (day/month/year) <b>21/11/2001</b>
Applicant <b>WESTVACO CORPORATION</b>		
This International Search Report has been prepared by this International Searching Authority and is transmitted to the applicant according to Article 18. A copy is being transmitted to the International Bureau.		
This International Search Report consists of a total of <u>4</u> sheets. <input checked="" type="checkbox"/> It is also accompanied by a copy of each prior art document cited in this report.		
<p>1. Basis of the report</p> <p>a. With regard to the language, the international search was carried out on the basis of the international application in the language in which it was filed, unless otherwise indicated under this item.</p> <p><input type="checkbox"/> the international search was carried out on the basis of a translation of the international application furnished to this Authority (Rule 23.1(b)).</p> <p>b. With regard to any nucleotide and/or amino acid sequence disclosed in the international application, the international search was carried out on the basis of the sequence listing:</p> <p><input type="checkbox"/> contained in the international application in written form.</p> <p><input type="checkbox"/> filed together with the international application in computer readable form.</p> <p><input type="checkbox"/> furnished subsequently to this Authority in written form.</p> <p><input type="checkbox"/> furnished subsequently to this Authority in computer readable form.</p> <p><input type="checkbox"/> the statement that the subsequently furnished written sequence listing does not go beyond the disclosure in the international application as filed has been furnished.</p> <p><input type="checkbox"/> the statement that the information recorded in computer readable form is identical to the written sequence listing has been furnished.</p> <p>2. <input type="checkbox"/> Certain claims were found unsearchable (See Box I).</p> <p>3. <input type="checkbox"/> Unity of invention is lacking (see Box II).</p> <p>4. With regard to the title,</p> <p><input checked="" type="checkbox"/> the text is approved as submitted by the applicant.</p> <p><input type="checkbox"/> the text has been established by this Authority to read as follows:</p> <p>5. With regard to the abstract,</p> <p><input checked="" type="checkbox"/> the text is approved as submitted by the applicant.</p> <p><input type="checkbox"/> the text has been established, according to Rule 38.2(b), by this Authority as it appears in Box III. The applicant may, within one month from the date of mailing of this international search report, submit comments to this Authority.</p> <p>6. The figure of the drawings to be published with the abstract is Figure No. <u>2</u></p> <p><input type="checkbox"/> as suggested by the applicant. <input type="checkbox"/> None of the figures.</p> <p><input type="checkbox"/> because the applicant failed to suggest a figure.</p> <p><input checked="" type="checkbox"/> because this figure better characterizes the invention.</p>		

Form PCT/ISA/210 (first sheet) (July 1998)

Received from <8437468494> at 12/10/02 4:36:38 PM [Eastern Standard Time]



## INTERNATIONAL SEARCH REPORT

International Application No  
PCT/US 02/21621

A. CLASSIFICATION OF SUBJECT MATTER IPC 7 F02M25/08 B01D53/04		
According to International Patent Classification (IPC) or to both national classification and IPC		
B. FIELDS SEARCHED Minimum documentation searched (classification system followed by classification symbols) IPC 7 F02M B01D		
Documentation searched other than minimum documentation to the extent that such documents are included in the fields searched		
Electronic data base consulted during the International search (name of data base and, where practical, search terms used) EPO-Internal		
C. DOCUMENTS CONSIDERED TO BE RELEVANT		
Category	Citation of document, with indication, where appropriate, of the relevant passages	Relevant to claim No.
X	EP 1 113 163 A (TENNEK CORP) 4 July 2001 (2001-07-04)  column 18, paragraph 64; claims 1-6; figures 7-12	1-8, 11, 12, 14-16, 18-21, 24-29
X	WO 01 62367 A (MACDOWALL JAMES DUFF ; KLEIJ MICHIEL TRIJNISSE (NL); KLEUT DIRK VAN) 30 August 2001 (2001-08-30) page 4, line 9-29 page 5, line 15-20; claims	1-9, 11, 18-22, 24
-/-		
<input checked="" type="checkbox"/> Further documents are listed in the continuation of box C.		<input checked="" type="checkbox"/> Patent family members are listed in annex.
* Special categories of cited documents:		
*A* document defining the general state of the art which is not considered to be of particular relevance *E* earlier document but published on or after the international filing date *L* document which may throw doubts on priority claim(s) or which is cited to establish the publication date of another citation or other special reason (as specified) *O* document referring to an oral disclosure, use, exhibition or other means *P* document published prior to the international filing date but later than the priority date claimed		*T* later document published after the international filing date or priority date and not in conflict with the application but cited to understand the principle or theory underlying the invention *X* document of particular relevance; the claimed invention cannot be considered novel or cannot be considered to involve an inventive step when the document is taken alone *Y* document of particular relevance; the claimed invention cannot be considered to involve an inventive step when the document is combined with one or more other such documents, such combination being obvious to a person skilled in the art. *B* document member of the same patent family
Date of the actual completion of the international search  12 November 2002		Date of mailing of the international search report  19/11/2002
Name and mailing address of the ISA European Patent Office, P.B. 5016 Patentlaan 2 NL - 2260 HW Rijswijk Tel. (+31-70) 340-2040, Tx. 31-651 epo nl, Fax: (+31-70) 340-3016		Authorized officer  Gruber, M

Form PCT/ISA/210 (second sheet) (July 1992)

page 1 of 2

Received from &lt;8437468494&gt; at 12/10/02 4:36:38 PM [Eastern Standard Time]

**INTERNATIONAL SEARCH REPORT**

International Application No  
PCT/US 02/21621

G.(Continuation) DOCUMENTS CONSIDERED TO BE RELEVANT		
Category *	Citation of document, with indication, where appropriate, of the relevant passages	Relevant to claim No.
X	US 2001/020418 A1 (ITAKURA YUJI ET AL) 13 September 2001 (2001-09-13)  page 3, paragraphs 44,45	1,2,4,8, 11,15, 18,19, 21,24,26
A	WO 92 01585 A (BRITISH PETROLEUM CO PLC) 6 February 1992 (1992-02-06) the whole document	
A	US 5 460 136 A (YAMAZAKI KAZUMI ET AL) 24 October 1995 (1995-10-24) cited in the application the whole document	
A	US 6 279 548 B1 (REDDY SAM RAGHUMA) 28 August 2001 (2001-08-28) the whole document	

1

Form PCT/ISA/210 (continuation of second sheet) (July 1992)

**INTERNATIONAL SEARCH REPORT**

Information on patent family members

International Application No  
PCT/US 02/21621

Patent document cited in search report		Publication date	Patent family member(s)	Publication date
EP 1113163	A	04-07-2001	JP 2001248504 A DE 1113163 T1 EP 1113163 A2 US 2001015134 A1	14-09-2001 17-01-2002 04-07-2001 23-08-2001
WO 0162367	A	30-08-2001	AU 3621301 A WO 0162367 A1	03-09-2001 30-08-2001
US 2001020418	A1	13-09-2001	JP 2001182631 A	06-07-2001
WO 9201585	A	06-02-1992	AU 8281391 A WO 9201585 A1	18-02-1992 06-02-1992
US 5460136	A	24-10-1995	JP 2934699 B2 JP 7174050 A	16-08-1999 11-07-1995
US 6279548	B1	28-08-2001	NONE	

Form PCT/ISA/210 (patent family annex) (July 1992)

Received from &lt;8437468494&gt; at 12/10/02 4:36:38 PM [Eastern Standard Time]

Approved for use through 10/31/2002. OMB 0851-0032  
 U.S. Patent and Trademark Office, U.S. DEPARTMENT OF COMMERCE  
 Under the Paperwork Reduction Act of 1995, no persons are required to respond to a collection of information unless it displays a valid OMB control number.

<h1 style="text-align: center;">FEE TRANSMITTAL</h1> <h2 style="text-align: center;">for FY 2002</h2> <p style="text-align: center; font-size: small;">Patent fees are subject to annual revision.</p>		Complete if Known	
		Application Number	10/100,362
TOTAL AMOUNT OF PAYMENT		(\$)	1050.00
		Filing Date	03/18/2002
		First Named Inventor	L. H. HILTZIK
		Examiner Name	Frank M. Lawrence Jr.
		Group Art Unit	1724
		Attorney Docket No.	CHR 2001-79

RECEIVED  
 JAN 27 2003  
 CTC 1700

**METHOD OF PAYMENT**

1.  The Commissioner is hereby authorized to charge indicated fees and credit any overpayments to:

Deposit Account Number: 23-1160  
 Deposit Account Name: Westvaco Corporation

Charge Any Additional Fee Required Under 37 CFR 1.16 and 1.17  
 Applicant claims small entity status. See 37 CFR 1.27

**FEE CALCULATION (continued)**

3. ADDITIONAL FEES		Large Entity	Small Entity	Fee Description	Fee Paid
Fee Code (\$)	Fee Code (\$)	Fee Code (\$)	Fee Code (\$)		
106	130	205	65	Surcharge - late filing fee or oath	
127	50	227	25	Surcharge - late provisional filing fee or cover sheet	
139	130	139	130	Non-English specification	
147	2,520	147	2,520	For filing a request for <i>ex parte</i> reexamination	
112	920*	112	920*	Requesting publication of SIR prior to Examiner action	
113	1,840*	113	1,840*	Requesting publication of SIR after Examiner action	
115	110	215	55	Extension for reply within first month	
116	400	215	200	Extension for reply within second month	
117	920	217	460	Extension for reply within third month	
118	1,440	218	720	Extension for reply within fourth month	
128	1,960	228	980	Extension for reply within fifth month	
119	320	219	160	Notice of Appeal	
120	320	220	160	Filing a brief in support of an appeal	
121	280	221	140	Request for oral hearing	
138	1,510	138	1,510	Petition to institute a public use proceeding	
140	110	240	55	Petition to revive - unavoidable	
141	1,280	241	640	Petition to revive - unintentional	
142	1,280	242	640	Utility issue fee (or reissue)	
143	480	243	230	Design issue fee	
144	820	244	310	Plant issue fee	
122	130	122	130	Petitions to the Commissioner	
123	60	123	50	Processing fee under 37 CFR 1.17(g)	
125	180	125	180	Submission of Information Disclosure Stmt	180.00
581	40	581	40	Recording each patent assignment per property (times number of properties)	
146	740	246	370	Filing a submission after final rejection (37 CFR § 1.129(a))	
149	740	249	370	For each additional invention to be examined (37 CFR § 1.129(b))	
179	740	279	370	Request for Continued Examination (RCE)	740.00
189	900	189	900	Request for expedited examination of a design application	
Other fee (specify): Petition to Commissioner					130.00
*Reduced by Basic Filing Fee Paid					<b>SUBTOTAL (3) (\$)</b> 1050.00

**FEE CALCULATION**

**1. BASIC FILING FEE**

Large Entity Fee Code (\$)	Small Entity Fee Code (\$)	Fee Description	Fee Paid		
101	740	201	370	Utility filing fee	
106	330	206	165	Design filing fee	
107	510	207	255	Plant filing fee	
108	740	208	370	Reissue filing fee	
114	160	214	80	Provisional filing fee	
<b>SUBTOTAL (1)</b>			<b>(\$)</b>		

**2. EXTRA CLAIM FEES**

Total Claims	Extra Claims	Fee from below	Fee Paid
Independent Claims	-20** =	X	
Multiple Dependant	-3** =	X	

Large Entity Fee Code (\$)	Small Entity Fee Code (\$)	Fee Description	Fee Paid		
103	18	203	9	Claims in excess of 20	
102	84	202	42	Independent claims in excess of 3	
104	280	204	140	Multiple dependant claim, if not paid	
109	84	209	42	** Reissue independent claims over original patent	
110	18	210	9	** Reissue claims in excess of 20 and over original patent	
<b>SUBTOTAL (2)</b>			<b>(\$)</b>		

<b>SUBMITTED BY</b>		Complete (if applicable)	
Name (Print/Type)	Terry B. McDaniel	Registration No. (Attorney/Agent)	28,444
Signature	<i>Terry B. McDaniel</i>	Telephone	(843) 740-2331
		Date	12/10/2002

**WARNING:** Information on this form may become public. Credit card information should not be included on this form. Provide credit card information and authorization on PTO-2038.

Burden Hour Statement: This form is estimated to take 0.2 hours to complete. Time will vary depending upon the needs of the individual case. Any comments on the amount of time you are required to complete this form should be sent to the Chief Information Officer, U.S. Patent and Trademark Office, Washington, DC 20231. DO NOT SEND FEES OR COMPLETED FORMS TO THIS ADDRESS. SEND TO: Assistant Commissioner for Patents, Washington, DC 20231.

Received from <8437468494> at 12/10/02 4:36:38 PM [Eastern Standard Time]

#9

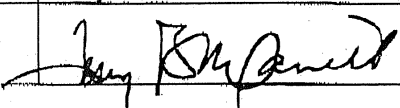
<b>REQUEST FOR CONTINUED EXAMINATION (RCE) TRANSMITTAL</b> 35 USC 132(b) effective May 29, 2000	Serial No:	10/100,362
	Filing Date:	March 18, 2001
	First Named Inventor:	L. H. Hiltzik
	Group Art Unit:	1724
	Examiner:	F. M. Lawrence Jr.
	Attorney Docket No:	CHR 2001-79
This is a Request for Continued Examination (RCE) under 37 C.F.R. § 1.114 for the above identified application.		
<b>1. Submission required under 37 C.F.R. § 1.114</b> a. <input type="checkbox"/> Previously submitted i. <input type="checkbox"/> Consider the amendment(s)/reply under 37 C.F.R. § 1.16 filed on ii. <input type="checkbox"/> Consider the arguments in the Appeal Brief/Reply Brief filed on iii. <input type="checkbox"/> Other: b. <input checked="" type="checkbox"/> Enclosed i. <input type="checkbox"/> Amendment/Reply ii. <input checked="" type="checkbox"/> Affidavit(s)/ <b>Declaration(s) in support of Petition to Withdraw From Issue</b> iii. <input checked="" type="checkbox"/> Information Disclosure Statement (IDS) PTO-1449 and copies of references iv. <input checked="" type="checkbox"/> Other: Petition to Withdraw from Issue		
<b>2. Miscellaneous</b> a. <input type="checkbox"/> Suspension of action on the above-identified application is requested under 37 C.F.R. § 1.103(c) for a period of _____ months. (Period of suspension shall not exceed 3 months; fee under 37 C.F.R. § 1.17(i) required.) b. <input type="checkbox"/> Other:		
<b>3. Fees</b> a. <input checked="" type="checkbox"/> The Director is hereby authorized to charge the following fees, or credit any overpayment to <b>Deposit Account No. 23-1160</b> . i. <input type="checkbox"/> RCE fee required under 37 C.F.R. § 1.17(e). ii. <input type="checkbox"/> Extension of time fee (37 C.F.R. § 1.138 and 1.17). iii. <input type="checkbox"/> Other: b. <input type="checkbox"/> Check in the amount of \$ _____ is enclosed. c. <input type="checkbox"/> Payment is made by credit card (Form PTO-2038 enclosed). d. <input checked="" type="checkbox"/> Fee Transmittal Form authorizing to charge indicated fees (PTO/SB/17 enclosed)		
<b>SIGNATURE OF APPLICANT, ATTORNEY OR AGENT REQUIRED</b>		
Name:	Terry B. McDaniel	Registration Number: 28,444
Signature:		Date: December 10, 2002

12/11/2002 AKELLEY 00000016 231160 10100362

02 FC:1801 740.00 CH

FAX RECEIVED

DEC 11 2002

PETITIONS OFFICE

Sent By: CTC;

8437468494;

Dec-11-02 9:14AM;

Page 10

#8

Case Docket No. CHR 2001-79  
Serial No. 10/100,362

IN THE UNITED STATES PATENT AND TRADEMARK OFFICE

Applicant: L. H. Hiltzik, J. Z. Jagiello, E. D. Tolles, R. S. Williams

Serial No.: 10/100,362

Group Art Unit: 1724

Filed: 03/18/02

For: Method For Reducing Emissions From Evaporative Emission Control Systems

Examiner: Frank M. Lawrence Jr.

Honorable Commissioner of  
Patents and Trademarks  
Washington, DC 20231

FAX RECEIVED

DEC 11 2002

PETITIONS OFFICE

INFORMATION DISCLOSURE STATEMENT

Dear Sir:

Under the provisions of 37 C.F.R. §§ 1.56, 1.97, and 1.98, applicant submits herewith copies of publication that the Office may wish to consider in continued examination of the subject application. The publications are listed on the attached form PTO-1449.

I hereby certify that each item of information contained in this information disclosure statement was first cited in a communication, dated November 19, 2002, from a foreign patent office in a counterpart foreign application and first came to the attention of the undersigned attorney on December 2, 2002, after being forwarded from the corporate receiving office for such correspondence in Atlanta, GA. The Commissioner is hereby authorized to charge the fee set forth in 37 C.F.R. §1.17 (p) in the amount of \$180.00, which is listed on the enclosed Fee Transmittal form.

Allowability of the claims of the instant application was based on the examiner's finding that "the closest prior art discloses evaporative emission control systems comprising different

Case Docket No. CHR 2001-79  
Serial No. 10/100,362

sorbents for reducing diurnal breathing but fails to suggest using sorbents having the (specified) butane working capacities.”

Of the six documents cited in the attached International Search Report, describing canisters with layers or compartments containing different adsorbents or containing heat absorbing or heat generating media, three are considered to define the general state of the art but are “not considered to be of particular relevance.” These are WO 92 01585 A to British Petroleum Co., U.S. Patent No. 5,460,136 to Yamazaki et al., and U.S. Patent No. 6,279,548 to Reddy.

WO 92 01585 A describes the use of two different adsorbents to improve canister working capacity. The first adsorbent is conventional activated carbon, and the second is selected from a group of adsorbent organic polymers. A claimed feature is that purge gas first enters the activated carbon component. The disclosure of the instant application, on the other hand, teaches that for bleed emission control the purge gas must first enter the special adsorbent, not the conventional activated carbon component. The invention claimed is consistent with such teaching, and it is respectfully submitted that there is no suggestion of such invention in WO 92 01585 A.

Yamazaki, et al., in US 5,460,136 A, consider an evaporative emission control system with more than one chamber, which improves adsorption efficiency when the system is used to capture both on-board refueling and other evaporative losses. It is respectfully submitted that this teaching is irrelevant to the invention of the instant application because the patent teaching only concerns canister hardware, not the properties of the adsorbent contained therein.

Reddy, in US 6,279,548 B1, describes a canister having more than one chamber that achieves improved regeneration by heating a volume of adsorbent at the purge inlet. The disclosure of the instant application does not teach heating the adsorbent; therefore, such feature is not claimed by the applicants.

In view of the above descriptions of the cited references, it is apparent that their designation as by the international searching authority “not particularly relevant” is accurate.

The remaining three references cited in the International Search Report, however, were designated to be “of particular relevance.” Therefore, it was deemed that compliance with the disclosure requirements of 37 C.F.R. §§ 1.56, 1.97, and 1.98 required the necessary effort to have the application withdrawn from issue, even though the issue fee had been paid, to request continued examination for their consideration by the examiner in resolving the issue of patentability.

Case Docket No. CHR 2001-79  
Serial No. 10/100,362

The additional cited references include EP 11 13163 to Tennex Corporation, WO 01 62367 to MacDowall et al., and U.S. Patent No. 6,488,748 to Yamafuji et al. (formerly an application published as US 2001-0020418).

The International Search Report also included a copy of the search results for the published application, EP 1,113,163, of Tennex. The document discloses an improvement in "conventional" vapor treatment technology as disclosed by Japanese Patent Provisional Publication No. 9-112356. The document describes a canister that comprises a single compartment with layers of adsorbent and alternate layers of heat accumulative material. The EP application describes a canister containing an adsorbent mixed with a heat absorbing material that has a heat capacity higher than that of the adsorbent, and considers multiple chambers and layer configurations designed to overcome drawbacks of the earlier design. In each of these inventions, canister working capacity is proposed to increase over canisters filled with adsorbent alone because heat produced during uptake of vapor is absorbed to a greater extent, so that the temperature of the adsorbent does not increase as much as it would in the absence of the heat absorbing material. Likewise the temperature would not decrease as much during regeneration. Therefore, more vapors would be picked-up during adsorption and more removed during purge. The EP application contends that this strategy is so effective that engine operation may be disrupted by too much vapor being released during regeneration purge. The object of the EP application is to overcome this drawback by physical arrangement of the different layers of adsorbent and heat absorbing materials, and by particular constructions of the adsorption canister.

The parts of EP 1,113,163 cited as relevant to the instant application are:

Pg 18, Para 64, which describes a honeycomb form of adsorbent incorporating a dispersed mixture of adsorbent, binder, and heat accumulative material. The previous paragraph lists aluminum, aluminum alloy, and ceramic as examples of heat accumulative materials.

Claims 1-6 specify different arrangements of canisters incorporating fuel adsorbing and heat accumulative materials, wherein the heat accumulative material has a heat capacity higher than that of the adsorbent.

Figs 1-7 show different canister configurations and different ways of partitioning fuel adsorbing and heat accumulative materials.

The Tennex application teaches that the working capacity of automotive fuel treatment canisters can be improved by incorporation of heat accumulating materials into the canister or directly into an adsorbent form such as a honeycomb. This is quite different from the object of the invention claimed in the instant application, which is directed more specifically toward control of diurnal bleed emissions from automotive canisters, and on a volume basis, use of the invention actually tends to decrease the working capacity of the canister system. The applicants' disclosure teaches that the canister system should consist of a volume of fuel adsorbing material



Case Docket No. CHR 2001-79  
Serial No. 10/100,362

with high adsorption capacity, and a separate volume of bleed control adsorbent. The bleed control adsorbent preferably has a high adsorption capacity on a mass basis, but is distributed in space so that its volumetric capacity is relatively low according to a claimed range. The distribution in space of the adsorbent can be attained by different means, one of which is dispersion by the addition of diluents and/or binders. However, such dispersing materials are not required to have a heat capacity even as high as the adsorbent itself. The applicants' experiments showed, for example, that when activated carbon was dispersed in a pellet by dilution with glass microbeads, the performance in control of bleed emissions was the same whether the beads were solid, with a relatively high heat capacity, or hollow, with a relatively low heat capacity. Coincidentally, honeycomb forms of activated carbon made by extrusion of a mixture of carbon and clays under our commonly-assigned patent contain components which could contribute to heat absorption, but good performance of honeycomb elements in bleed control is not related to this. A honeycomb element contains so little carbon (in relation to the clay-based material) that heat exchange with purge gas easily offsets the cooling due to desorption during purge, which would be appreciated by one skilled in the art. Furthermore, little heat is generated during the adsorption of bleed emissions because both the vapor concentration and flow rate influent to the honeycomb is very small.

It is respectfully submitted, therefore, that the teaching of published application EP 11 13163 would not suggest, to one skilled in the art, the claimed invention of the instant application.

Macdowall, et al., in WO 01 6267 A, describe a canister system that uses a layered bed consisting of a first layer of conventional activated carbon and a smaller second layer of another adsorbent with faster adsorption kinetics. Optionally, the two layers might be located in separate containers. In either case, the adsorbent with faster kinetics is located to receive first contact with purge air during regeneration. Pelletized activated carbon is cited as an example of conventional adsorbent. Examples of adsorbents with faster kinetics include materials with smaller particle size, or other favorable shape, and materials with a favorable but undefined pore size distribution. The only supporting data concerns use of smaller particle size for the second layer, and the most preferred embodiment of this invention is stated to be characterized by the external particle surface-area-to-volume ratios of the smaller and larger particles in the two layers.

Pg 4, Ln 9-29, noted by the searcher, discusses use of two separate adsorbents, differentiated by adsorption kinetics.

The claimed invention of the instant application does not rely upon adsorption kinetics to obtain desired performance. Required dilution of carbon particles in a matrix of nonadsorbent material would actually be expected to cause slower adsorption kinetics for the some of our

Case Docket No. CHR 2001-79  
Serial No. 10/100,362

claimed embodiments. Thus, a teaching of reliance on adsorption kinetics would not suggest what the applicants did, as defined by the claims of the instant application.

Pg 5, Ln 15-20, also noted by the searcher, states

The amount of adsorbents is selected such that the adsorption capacity in the lower heat capacity section is greater than the capacity in the higher heat capacity section. This generally means that the weight of adsorbent in the lower heat capacity section is greater than the weight of adsorbent in the higher heat capacity section.

This feature of the MacDowall et al. invention is based on the necessity of restricting the increase in pressure drop resulting from use of smaller particles, and on observed improvements in experimental breakthrough performance. It must be noted, however, that the demonstrated improvement was obtained using different particle sizes of the same carbon in the first and second layers. While this clearly supports the kinetic concept expounded by their invention, it is not relevant to the applicants' claimed invention, which teaches the use of different adsorbents with a particular range of equilibrium volumetric capacity in the second layer.

Finally, the searcher noted the "claims" to be somehow relevant. However, the claims of the reference principally concern adsorption rate and particle size of first and second adsorbents. None of which are relevant to our invention, as it places no reliance on kinetics or particle size.

Lastly, Yamafuji et al., in U.S. Patent No. 6,488,748/US 2001/020418 A1, describe a canister system with two or more compartments or layers containing a conventional adsorbent in the first layer, and material with higher heat capacity in the second layer. The higher heat capacity can be produced by selecting a particular adsorbent with a high heat capacity, or by mixing another material with high heat capacity with the adsorbent in this layer. Goals are the same as in the Tennex published application EP 1,113,163.

Attention was called by the searcher to:

Pg 3, paragraphs 44 and 45, which report that the heat capacity of the second layer can be increased by adding particles of materials with higher specific heat and thermal conductivity including alumina, glass, etc., iron, copper, lead, etc.

The applicants' claimed invention may use glass, or clays containing alumina, in a dispersive matrix with carbon to dilute the adsorptive activity of the carbon component, but beneficial properties are in no way based on heat management, and it is coincidental that such materials may also increase heat capacity. It is respectfully submitted that there is no teaching or

Case Docket No. CHR 2001-79  
Serial No. 10/100,362

claimed embodiments. Thus, a teaching of reliance on adsorption kinetics would not suggest what the applicants did, as defined by the claims of the instant application.

Pg 5, Ln 15-20, also noted by the searcher, states

The amount of adsorbents is selected such that the adsorption capacity in the lower heat capacity section is greater than the capacity in the higher heat capacity section. This generally means that the weight of adsorbent in the lower heat capacity section is greater than the weight of adsorbent in the higher heat capacity section.

This feature of the MacDowall et al. invention is based on the necessity of restricting the increase in pressure drop resulting from use of smaller particles, and on observed improvements in experimental breakthrough performance. It must be noted, however, that the demonstrated improvement was obtained using different particle sizes of the same carbon in the first and second layers. While this clearly supports the kinetic concept expounded by their invention, it is not relevant to the applicants' claimed invention, which teaches the use of different adsorbents with a particular range of equilibrium volumetric capacity in the second layer.

Finally, the searcher noted the "claims" to be somehow relevant. However, the claims of the reference principally concern adsorption rate and particle size of first and second adsorbents. None of which are relevant to our invention, as it places no reliance on kinetics or particle size.

Lastly, Yamafuji et al., in U.S. Patent No. 6,488,748/US 2001/020418 A1, describe a canister system with two or more compartments or layers containing a conventional adsorbent in the first layer, and material with higher heat capacity in the second layer. The higher heat capacity can be produced by selecting a particular adsorbent with a high heat capacity, or by mixing another material with high heat capacity with the adsorbent in this layer. Goals are the same as in the Tennex published application EP 1,113,163.

Attention was called by the searcher to:

Pg 3, paragraphs 44 and 45, which report that the heat capacity of the second layer can be increased by adding particles of materials with higher specific heat and thermal conductivity including alumina, glass, etc., iron, copper, lead, etc.

The applicants' claimed invention may use glass, or clays containing alumina, in a dispersive matrix with carbon to dilute the adsorptive activity of the carbon component, but beneficial properties are in no way based on heat management, and it is coincidental that such materials may also increase heat capacity. It is respectfully submitted that there is no teaching or

Case Docket No. CHR 2001-79  
Serial No. 10/100,362

suggestion that the adsorbents disclosed by Yamafuji et al. fall within the specifically defined ranges of adsorption capacity claimed by the applicants.

In his earlier statement of reasons for allowance that resulted in this application's post-issue fee paid status, the Examiner noted that the applicants' claimed "method for reducing fuel vapor emissions in automotive evaporative emissions control systems comprising the steps of contacting the fuel vapor with an initial adsorbent volume having incremental adsorption capacity at 25°C of greater than 35 g n-butane/L between vapor concentrations of 5 vol% and 50 vol% n-butane and at least one subsequent adsorbent volume having an incremental adsorption capacity of less than 35 g n-butane/L between vapor concentrations of 5 vol% and 50 vol% n-butane is not taught, disclosed or suggested in a single reference or a combination of references in the prior art of record." It is respectfully submitted that, having placed the above disclosed and discussed prior art in the record of examination of the instant application, that statement by the examiner remains true. Moreover, the Examiner's further statement that "The closest prior art discloses evaporative emission prevention systems comprising different sorbents for reducing diurnal breathing but fails to suggest using sorbents having the butane working capacities specified above [in applicants' claim 1]." It is respectfully submitted that, having placed the above disclosed and discussed prior art in the record of examination of the instant application, that statement by the examiner also remains true.

Although noted of varying degrees of relevance in an international search report in a foreign application filing based on the instant U.S. application, these citations do not necessarily constitute an admission that the references are relevant or material to the claims; they are cited only as constituting the closest art of which the applicant has recently been made aware.

Respectfully Submitted,

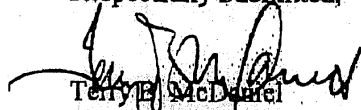

Terry J. McDuffie  
Attorney for the Applicants  
Registration No. 28,444

Attachments

Dated: December 10, 2002  
5255 Virginia Avenue  
Post Office Box 118005  
Charleston, SC 29423-8005  
(843) 746-8493

Sheet 1 of 1

<b>Form PTO-1449 (REV. 8-83)</b>		U.S. DEPT. OF COMMERCE PATENT AND TRADEMARK OFFICE		App. Packet No. <b>CHR 2001-79</b>	SERIAL NO. <b>10/100,362</b>
<b>INFORMATION DISCLOSURE CITATION</b> (Use several sheets if necessary)				APPLICANT <b>L.H. Hiltzik, J.Z. Jagiello, E.D. Tolles, and R.S. Williams</b>	
				FILING DATE <b>03/18/02</b>	GROUP <b>1725</b>

U.S. PATENT DOCUMENTS												
*EXAMINER INITIAL	DOCUMENT NUMBER							DATE	NAME	CLASS	SUBCLASS	FILING DATE IF APPROPRIATE
<i>LL</i>	5	4	6	0	1	3	6	10/95	Yamazaki et al.	<u>        </u>	<u>        </u>	
<i>RL</i>	6	2	7	9	5	4	8	08/01	Reddy	<u>        </u>	<u>        </u>	
<i>LL</i>	6	4	8	8	7	4	8	12/02	Yamafuji et al. (Publication No. US 2001-0020418 (09/01))	<u>        </u>	<u>        </u>	

FOREIGN PATENT DOCUMENTS													
*EXAMINER INITIAL	DOCUMENT NUMBER							DATE	COUNTRY	CLASS	SUBCLASS	TRANSLATION	
	YRS		NO										
<i>LL</i>	EP	11	1	3	1	6	3	7/01	European Patent Office Publication	<u>        </u>	<u>        </u>		
<i>LL</i>	WO	01	6	2	3	6	7	8/01	PCT Publication	<u>        </u>	<u>        </u>		
<i>LL</i>	WO	92	0	1	5	8	5	9/92	PCT Publication	<u>        </u>	<u>        </u>		

OTHER DOCUMENTS (Including Author, Title, Date, Pertinent Pages, Etc.)	

EXAMINER <i>Frank Lawrence</i>	DATE CONSIDERED <i>1-14-03</i>
-----------------------------------	-----------------------------------

\*EXAMINER: Initial if citation considered, whether or not citation is in conformance with MPEP 609; Draw line through citation if not in conformance and not considered. Include copy of this form with next communication with applicant.

#10

Case Docket No. CHR 2001-79

**IN THE UNITED STATES PATENT AND TRADEMARK OFFICE**

In re Application of: L. H. Hiltzik, J. Z. Jagiello, E. D. Tolles, R. S. Williams

Filed: March 18, 2002 Group Art Unit: 1724

Serial No.: 10/100,362

For: "Method For Reducing Emissions From Evaporative Emission Control Systems"

Examiner: Frank M. Lawrence

Assistant Commissioner for Patents  
U. S. Patent and Trademark Office  
Washington, D. C. 20231

**PETITION FOR WITHDRAWAL FROM ISSUE UNDER 37 C.F.R. §1.313(c)(2)**

Dear Sir:

Applicants hereby petition to have the above-described patent application withdrawn from issue under 37 C.F.R. §1.313(c)(2).

**1. Accompanying material**

Accompanying this petition is a declaration by

applicant

applicants' attorney

showing good and sufficient reasons why withdrawal of the application from issue is necessary.

FAX RECEIVED

DEC 11 2002

PETITIONS OFFICE

12/11/2002 AKELLEY 00000016 231160 10100362

01 FC:1460 130.00 CH

Case Docket No. CHR 2001-79  
Serial No. 10/100,362

**2. Fee**

In accordance with 37 C.F.R. §1.313, the fee set forth in 37 C.F.R. §1.17(h) is hereby submitted with this petition, as permission to authorize a charge to Deposit Account 23-1160.

Respectfully submitted,



Terry B. McDaniel  
Attorney for the Applicants  
Registration No. 28,444

Attachments  
December 10, 2002  
5525 Virginia Avenue  
P. O. Box 118005  
Charleston, South Carolina 29423-8005  
Phone (843) 740-2311  
FAX (843) 740-2335

Case Docket No. CHR 2001-79

**IN THE UNITED STATES PATENT AND TRADEMARK OFFICE**

In re Application of: L. H. Hiltzik, J. Z. Jagiello, E. D. Tolles, R. S. Williams

Serial No. 10/100,362

Filed: March 18, 2002

For: "Method For Reducing Emissions From Evaporative Emission Control Systems"

Examiner: Frank M. Lawrence

Assistant Commissioner for Patents  
 U. S. Patent and Trademark Office  
 Washington, D. C. 20231

FAX RECEIVED  
 DEC 11 2002

**DECLARATION IN SUPPORT OF  
 PETITION TO WITHDRAW FROM ISSUE UNDER 37 C.F.R. § 1.313(c)(2) PETITIONS OFFICE**

Dear Sir:

I, Terry B. McDaniel, Esq., declare as follows:

(1) I am an attorney-of-record for the applicants in the above-identified application and, having drafted the specification and claims thereof, I am fully aware of the subject matter of the invention thereof and of the field of invention in which it resides. Upon my receipt of the results of the prior art search conducted by the European Patent Office (EPO) in conjunction with the PTC filing based on the instant application, I was made aware for the first time of prior art references that appear to be material and relevant to the examination of the instant application, but have not been examined (which is a basis for this petition to have this application withdrawn from issue under 37 C.F.R. §1.313(c)(2)).

(2) The instant application describes a method for sharply reducing diurnal breathing loss emissions from automotive evaporative emissions canisters by the use of multiple layers, or stages, of adsorbents. On October 8, 2002, the Examiner mailed the notice of allowance of claims 1-30 responsive to the filing of the instant application. The issue fee was timely paid on November 11, 2002. To date, the application has not issued as a U.S. Patent.

In view of the facts set forth, the undersigned attorney-of-record in this application petitions for withdrawal of the application from issue for consideration of a request for continued examination in compliance with 37 C.F.R. §1.114(c). An Information Disclosure Statement



Case Docket No. CHR 2001-79

listing the newly discovered references, with some discussion to distinguish from the invention disclosed and claimed in the instant application, is also enclosed for consideration.

I declare further that all statements made herein of my own knowledge are true and that all statements made on information and belief are believed to be true and, further, that these statements were made with the knowledge that willful false statements and the like so made are punishable by fine or imprisonment, or both, under 18 USC § 1001 and that such false statements may jeopardize the validity of this document and the application to which it relates.

Signed at Charleston, South Carolina, this 10th day of December, 2002.

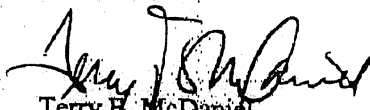

Terry B. McDaniel  
Attorney for the Applicants  
Registration No. 28,444

Enclosure

5255 Virginia Avenue  
P. O. Box 118005  
Charleston, SC 29423-8005  
Tel (843) 740-2311  
Fax (843) 740-2335

**MeadWestvaco**

**Facsimile**

#10

MeadWestvaco Corporation  
Charleston Technical Center - Law Dept.  
5255 Virginia Avenue  
P. O. Box 118005  
Charleston, SC 29423-8005

DATE: December 11, 2002  
TO: Petitions Office (Patent Assistance Center)  
COMPANY: United States Patent and Trademark Office  
FAX #: (703) 308-6916  
FROM: Terry B. McDaniel  
SENDER'S PHONE #: (843) 746-8493  
SENDER'S FAX #: (843) 746-8494  
SUBJECT: Petition to Withdraw from Issue and RCE  
TOTAL NUMBER OF PAGES: 142 (including cover sheet)

FAX RECEIVED  
DEC 11 2002  
PETITIONS OFFICE

Serial No. 10/100,362  
Date Filed March 18, 2002  
Title: Method For Reducing Emissions From Evaporative Emissions Control Systems  
Inventors: L. H. Hiltzik et al.  
Examiner: Frank M. Lawrence Jr.

Attached please find a duplicate fax, which was sent on 12/10/02 containing the following:

- Confirmation of Receipt of 133 pages from the USPTO regarding fax sent 12/10/02
- Certificate of Transmission under 37 CFR 1.8 dated 12/10/02
- Fee Transmittal Form PTO/SB/17
- Petition to Withdraw from Issue Under 37 CFR 1.313(c)(2)
- Declaration in Support of Petition
- Request for Continued Examination (RCE) Transmittal Form
- Information Disclosure Statement
- PTO - 1449
- Copies of Cited Art.

Thank you for your kind attention to this matter. If you require any additional information, please do not hesitate to contact me.

*This entire transmission is intended only for the use of the individual or entity to which it is addressed and may contain information that is privileged, confidential, and exempt from disclosure under applicable law. If the reader of this message is not intended recipient, or the employee or agent responsible for delivering the message of the intended recipient, you are hereby notified that any dissemination, distribution, or copying of this communication is strictly prohibited. If you have received this communication in error, please notify us immediately by telephone and return the original message to us at the above address via the U.S. Postal Service. You will be reimbursed for all reasonable expenses.*

Case Docket No. CHR 2001-79  
Serial No. 10/100,362

**Certificate of Transmission under 37 CFR 1.8**

I hereby certify that this correspondence is being facsimile transmitted to the United States Patent and Trademark Office

On December 10, 2002.  
Date

  
 \_\_\_\_\_  
 Terry B. McDaniel  
 Attorney for the Applicants  
 Registration No. 28,444  
 \_\_\_\_\_  
Typed or printed name of person signing Certificate

FAX RECEIVED  
DEC 11 2002  
PETITIONS OFFICE

Note: Each paper must have its own certificate of transmission, or this certificate must identify each submitted paper.

Fcc Transmittal Form PTO/SB/17  
Petition to Withdraw from Issue Under 37 CFR 1.313 (c)(2)  
Declaration in Support of Petition  
Request for Continued Examination (RCE) Transmittal form  
Information Disclosure Statement  
PTO-1449  
Copies of Cited Art

*Total 140 pages*

Sent By: CTC; 8437468494; Dec-11-02 9:12AM; Page 2  
USPTO 12/10/02 5:24 PAGE 1/1 NIGHTFAX  
O:Auto-reply fax to 8437468494 COMPANY:

## Auto-Reply Facsimile Transmission



UNITED STATES  
PATENT AND  
TRADEMARK OFFICE

TO: Fax Sender at 8437468494  
Fax Information  
Date Received: 12/10/02 4:36:38 PM [Eastern Standard Time]  
Total Pages: 133 (including cover page)

**ADVISORY:** This is an automatically generated return receipt confirmation of the facsimile transmission received by the Office. Please check to make sure that the number of pages listed as received in Total Pages above matches what was intended to be sent. Applicants are advised to retain this receipt in the unlikely event that proof of this facsimile transmission is necessary. Applicants are also advised to use the certificate of facsimile transmission procedures set forth in 37 CFR 1.8(a) and (b), 37 CFR 1.6(f). Trademark Applicants, also see the Trademark Manual of Examining Procedure (TMEP) section 306 et seq.

Received  
Cover  
Page

=====>

Sent By: CTC; 8437468494; Dec-10-02 4:36PM; Page 1

Case Docket No. CNK 2001-79  
Serial No. 10/100,162

Certificate of Transmission under 37 CFR 1.8

I hereby certify that this correspondence is being facsimile transmitted to the United States Patent and Trademark Office

On December 10, 2002  
Date

  
Terry B. McDonald  
Attorney for the Applicant  
Registration No. 28,424  
Printed or typed name of person signing Certificate

Note: Each page must have its own certificate of transmission, or this certificate must identify each individual page.

Fee Transmittal Form PTO/SB/17  
Petition to Withdraw from Issue Under 37 CFR 1.313 (c)(2)  
Declaration in Support of Petition  
Request for Continued Examination (RCE) Transmittal Form  
Information Disclosure Statement  
PTO-1449  
Copies of Claim Art

Total 140 pages

Received from: 8437468494 at 12/10/02 4:36:38 PM [Eastern Standard Time]

FAX RECEIVED

DEC 11 2002

PETITIONS OFFICE

PTO/BB/17 (10-01)

Approved for use through 10/31/2002. OMB 0651-0032  
U.S. Patent and Trademark Office; U.S. DEPARTMENT OF COMMERCE

Under the Paperwork Reduction Act of 1995, no persons are required to respond to a collection of information unless it displays a valid OMB control number.

<b>FEE TRANSMITTAL for FY 2002</b>		<i>Patent fees are subject to annual revision.</i>	
		<b>TOTAL AMOUNT OF PAYMENT (\$)</b> 1050.00	
<b>Complete If Known</b>			
Application Number	10/100,362		
Filing Date	03/18/2002		
First Named Inventor	L. F. HILTZIK		
Examiner Name	Frank M. Lawrence Jr.		
Group Art Unit	1724		
Attorney Docket No.	CHR 2001-79		

**TAX RECEIVED**  
DEC 11 2002  
PATENT OFFICE

<b>METHOD OF PAYMENT</b>		<b>FEE CALCULATION (continued)</b>																																																																																																																																																																	
<p>1. <input checked="" type="checkbox"/> The Commissioner is hereby authorized to charge indicated fees and credit any overpayments to:</p> <p>Deposit Account Number: 23-1160 Deposit Account Name: Westvaco Corporation</p> <p><input checked="" type="checkbox"/> Charge Any Additional Fee Required Under 37 CFR 1.16 and 1.17 <input type="checkbox"/> Applicant claims small entity status. See 37 CFR 1.27</p>		<p>3. <b>ADDITIONAL FEES</b></p> <table border="1"> <thead> <tr> <th>Fee Code</th> <th>Large Entity (\$)</th> <th>Small Entity (\$)</th> <th>Fee Description</th> <th>Fee Paid</th> </tr> </thead> <tbody> <tr><td>105</td><td>130</td><td>65</td><td>Surcharge - late filing fee or oath</td><td></td></tr> <tr><td>127</td><td>50</td><td>25</td><td>Surcharge - late provisional filing fee or cover sheet</td><td></td></tr> <tr><td>139</td><td>130</td><td>65</td><td>Non-English specification</td><td></td></tr> <tr><td>147</td><td>2,520</td><td>1,260</td><td>For filing a request for ex parte reexamination</td><td></td></tr> <tr><td>112</td><td>920</td><td>460</td><td>Requesting publication of SIR prior to Examiner action</td><td></td></tr> <tr><td>113</td><td>1,840</td><td>920</td><td>Requesting publication of SIR after Examiner action</td><td></td></tr> <tr><td>115</td><td>110</td><td>55</td><td>Extension for reply within first month</td><td></td></tr> <tr><td>116</td><td>400</td><td>200</td><td>Extension for reply within second month</td><td></td></tr> <tr><td>117</td><td>920</td><td>460</td><td>Extension for reply within third month</td><td></td></tr> <tr><td>118</td><td>1,440</td><td>720</td><td>Extension for reply within fourth month</td><td></td></tr> <tr><td>128</td><td>1,960</td><td>980</td><td>Extension for reply within fifth month</td><td></td></tr> <tr><td>119</td><td>320</td><td>160</td><td>Notice of Appeal</td><td></td></tr> <tr><td>120</td><td>320</td><td>160</td><td>Filing a brief in support of an appeal</td><td></td></tr> <tr><td>121</td><td>280</td><td>140</td><td>Request for oral hearing</td><td></td></tr> <tr><td>138</td><td>1,510</td><td>755</td><td>Petition to institute a public use proceeding</td><td></td></tr> <tr><td>140</td><td>110</td><td>55</td><td>Petition to revive - unavoidable</td><td></td></tr> <tr><td>141</td><td>1,280</td><td>640</td><td>Petition to revive - unintentional</td><td></td></tr> <tr><td>142</td><td>1,280</td><td>640</td><td>Utility issue fee (or reissue)</td><td></td></tr> <tr><td>143</td><td>480</td><td>240</td><td>Design issue fee</td><td></td></tr> <tr><td>144</td><td>620</td><td>310</td><td>Plant issue fee</td><td></td></tr> <tr><td>122</td><td>130</td><td>65</td><td>Petitions to the Commissioner</td><td></td></tr> <tr><td>123</td><td>50</td><td>25</td><td>Processing fee under 37 CFR 1.17(q)</td><td></td></tr> <tr><td>126</td><td>180</td><td>90</td><td>Submission of Information Disclosure Stmt</td><td>180.00</td></tr> <tr><td>681</td><td>40</td><td>20</td><td>Recording each patent assignment per property (times number of properties)</td><td></td></tr> <tr><td>146</td><td>740</td><td>370</td><td>Filing a submission after final rejection (37 CFR § 1.129(a))</td><td></td></tr> <tr><td>149</td><td>740</td><td>370</td><td>For each additional invention to be examined (37 CFR § 1.129(b))</td><td>740.00</td></tr> <tr><td>179</td><td>740</td><td>370</td><td>Request for Continued Examination (RCE)</td><td></td></tr> <tr><td>169</td><td>900</td><td>450</td><td>Request for expedited examination of a design application</td><td></td></tr> <tr><td colspan="4">Other fee (specify) <b>Petition to Commissioner</b></td><td>130.00</td></tr> <tr><td colspan="4"><b>Reducted by Basic Filing Fee Paid</b></td><td></td></tr> <tr><td colspan="4"><b>SUBTOTAL (3) (\$)</b></td><td><b>1050.00</b></td></tr> </tbody> </table>		Fee Code	Large Entity (\$)	Small Entity (\$)	Fee Description	Fee Paid	105	130	65	Surcharge - late filing fee or oath		127	50	25	Surcharge - late provisional filing fee or cover sheet		139	130	65	Non-English specification		147	2,520	1,260	For filing a request for ex parte reexamination		112	920	460	Requesting publication of SIR prior to Examiner action		113	1,840	920	Requesting publication of SIR after Examiner action		115	110	55	Extension for reply within first month		116	400	200	Extension for reply within second month		117	920	460	Extension for reply within third month		118	1,440	720	Extension for reply within fourth month		128	1,960	980	Extension for reply within fifth month		119	320	160	Notice of Appeal		120	320	160	Filing a brief in support of an appeal		121	280	140	Request for oral hearing		138	1,510	755	Petition to institute a public use proceeding		140	110	55	Petition to revive - unavoidable		141	1,280	640	Petition to revive - unintentional		142	1,280	640	Utility issue fee (or reissue)		143	480	240	Design issue fee		144	620	310	Plant issue fee		122	130	65	Petitions to the Commissioner		123	50	25	Processing fee under 37 CFR 1.17(q)		126	180	90	Submission of Information Disclosure Stmt	180.00	681	40	20	Recording each patent assignment per property (times number of properties)		146	740	370	Filing a submission after final rejection (37 CFR § 1.129(a))		149	740	370	For each additional invention to be examined (37 CFR § 1.129(b))	740.00	179	740	370	Request for Continued Examination (RCE)		169	900	450	Request for expedited examination of a design application		Other fee (specify) <b>Petition to Commissioner</b>				130.00	<b>Reducted by Basic Filing Fee Paid</b>					<b>SUBTOTAL (3) (\$)</b>				<b>1050.00</b>
Fee Code	Large Entity (\$)	Small Entity (\$)	Fee Description	Fee Paid																																																																																																																																																															
105	130	65	Surcharge - late filing fee or oath																																																																																																																																																																
127	50	25	Surcharge - late provisional filing fee or cover sheet																																																																																																																																																																
139	130	65	Non-English specification																																																																																																																																																																
147	2,520	1,260	For filing a request for ex parte reexamination																																																																																																																																																																
112	920	460	Requesting publication of SIR prior to Examiner action																																																																																																																																																																
113	1,840	920	Requesting publication of SIR after Examiner action																																																																																																																																																																
115	110	55	Extension for reply within first month																																																																																																																																																																
116	400	200	Extension for reply within second month																																																																																																																																																																
117	920	460	Extension for reply within third month																																																																																																																																																																
118	1,440	720	Extension for reply within fourth month																																																																																																																																																																
128	1,960	980	Extension for reply within fifth month																																																																																																																																																																
119	320	160	Notice of Appeal																																																																																																																																																																
120	320	160	Filing a brief in support of an appeal																																																																																																																																																																
121	280	140	Request for oral hearing																																																																																																																																																																
138	1,510	755	Petition to institute a public use proceeding																																																																																																																																																																
140	110	55	Petition to revive - unavoidable																																																																																																																																																																
141	1,280	640	Petition to revive - unintentional																																																																																																																																																																
142	1,280	640	Utility issue fee (or reissue)																																																																																																																																																																
143	480	240	Design issue fee																																																																																																																																																																
144	620	310	Plant issue fee																																																																																																																																																																
122	130	65	Petitions to the Commissioner																																																																																																																																																																
123	50	25	Processing fee under 37 CFR 1.17(q)																																																																																																																																																																
126	180	90	Submission of Information Disclosure Stmt	180.00																																																																																																																																																															
681	40	20	Recording each patent assignment per property (times number of properties)																																																																																																																																																																
146	740	370	Filing a submission after final rejection (37 CFR § 1.129(a))																																																																																																																																																																
149	740	370	For each additional invention to be examined (37 CFR § 1.129(b))	740.00																																																																																																																																																															
179	740	370	Request for Continued Examination (RCE)																																																																																																																																																																
169	900	450	Request for expedited examination of a design application																																																																																																																																																																
Other fee (specify) <b>Petition to Commissioner</b>				130.00																																																																																																																																																															
<b>Reducted by Basic Filing Fee Paid</b>																																																																																																																																																																			
<b>SUBTOTAL (3) (\$)</b>				<b>1050.00</b>																																																																																																																																																															
<b>FEE CALCULATION</b>																																																																																																																																																																			
<p>1. <b>BASIC FILING FEE</b></p> <table border="1"> <thead> <tr> <th>Large Entity Code (\$)</th> <th>Large Entity Fee (\$)</th> <th>Small Entity Code (\$)</th> <th>Small Entity Fee (\$)</th> <th>Fee Description</th> <th>Fee Paid</th> </tr> </thead> <tbody> <tr><td>101</td><td>740</td><td>201</td><td>370</td><td>Utility filing fee</td><td></td></tr> <tr><td>106</td><td>330</td><td>206</td><td>165</td><td>Design filing fee</td><td></td></tr> <tr><td>107</td><td>510</td><td>207</td><td>255</td><td>Plant filing fee</td><td></td></tr> <tr><td>108</td><td>740</td><td>208</td><td>370</td><td>Reissue filing fee</td><td></td></tr> <tr><td>114</td><td>180</td><td>214</td><td>80</td><td>Provisional filing fee</td><td></td></tr> <tr><td colspan="5"><b>SUBTOTAL (1) (\$)</b></td><td></td></tr> </tbody> </table>		Large Entity Code (\$)	Large Entity Fee (\$)	Small Entity Code (\$)	Small Entity Fee (\$)	Fee Description	Fee Paid	101	740	201	370	Utility filing fee		106	330	206	165	Design filing fee		107	510	207	255	Plant filing fee		108	740	208	370	Reissue filing fee		114	180	214	80	Provisional filing fee		<b>SUBTOTAL (1) (\$)</b>																																																																																																																													
Large Entity Code (\$)	Large Entity Fee (\$)	Small Entity Code (\$)	Small Entity Fee (\$)	Fee Description	Fee Paid																																																																																																																																																														
101	740	201	370	Utility filing fee																																																																																																																																																															
106	330	206	165	Design filing fee																																																																																																																																																															
107	510	207	255	Plant filing fee																																																																																																																																																															
108	740	208	370	Reissue filing fee																																																																																																																																																															
114	180	214	80	Provisional filing fee																																																																																																																																																															
<b>SUBTOTAL (1) (\$)</b>																																																																																																																																																																			
<p>2. <b>EXTRA CLAIM FEES</b></p> <p>Total Claims: <input type="text"/> - 20** = <input type="text"/> X <input type="text"/> = <input type="text"/> Independent Claims: <input type="text"/> - 3** = <input type="text"/> X <input type="text"/> = <input type="text"/> Multiple Dependent: <input type="text"/> = <input type="text"/></p> <table border="1"> <thead> <tr> <th>Large Entity Code (\$)</th> <th>Large Entity Fee (\$)</th> <th>Small Entity Code (\$)</th> <th>Small Entity Fee (\$)</th> <th>Fee Description</th> <th>Fee Paid</th> </tr> </thead> <tbody> <tr><td>103</td><td>18</td><td>203</td><td>9</td><td>Claims in excess of 20</td><td></td></tr> <tr><td>102</td><td>84</td><td>202</td><td>42</td><td>Independent claims in excess of 3</td><td></td></tr> <tr><td>104</td><td>280</td><td>204</td><td>140</td><td>Multiple dependent claim, if not paid</td><td></td></tr> <tr><td>109</td><td>84</td><td>209</td><td>42</td><td>** Reissue independent claims over original patent</td><td></td></tr> <tr><td>110</td><td>18</td><td>210</td><td>9</td><td>** Reissue claims in excess of 20 and over original patent</td><td></td></tr> <tr><td colspan="5"><b>SUBTOTAL (2) (\$)</b></td><td></td></tr> </tbody> </table> <p>**or number previously paid, if greater; For Reissues, see above</p>		Large Entity Code (\$)	Large Entity Fee (\$)	Small Entity Code (\$)	Small Entity Fee (\$)	Fee Description	Fee Paid	103	18	203	9	Claims in excess of 20		102	84	202	42	Independent claims in excess of 3		104	280	204	140	Multiple dependent claim, if not paid		109	84	209	42	** Reissue independent claims over original patent		110	18	210	9	** Reissue claims in excess of 20 and over original patent		<b>SUBTOTAL (2) (\$)</b>																																																																																																																													
Large Entity Code (\$)	Large Entity Fee (\$)	Small Entity Code (\$)	Small Entity Fee (\$)	Fee Description	Fee Paid																																																																																																																																																														
103	18	203	9	Claims in excess of 20																																																																																																																																																															
102	84	202	42	Independent claims in excess of 3																																																																																																																																																															
104	280	204	140	Multiple dependent claim, if not paid																																																																																																																																																															
109	84	209	42	** Reissue independent claims over original patent																																																																																																																																																															
110	18	210	9	** Reissue claims in excess of 20 and over original patent																																																																																																																																																															
<b>SUBTOTAL (2) (\$)</b>																																																																																																																																																																			

<b>SUBMITTED BY</b>		<b>Complete (if applicable)</b>	
Name (Print Type)	Terry B. McDaniel	Registration No. (Attorney/Agent)	28,444
Signature	<i>Terry B. McDaniel</i>	Telephone	(843) 740-2331
		Date	12/10/2002

**WARNING: Information on this form may become public. Credit card information should not be included on this form. Provide credit card information and authorization on PTO-2038.**

Burden Hour Statement: This form is estimated to take 0.2 hours to complete. Time will vary depending upon the needs of the individual case. Any comments on the amount of time you are required to complete this form should be sent to the Chief Information Officer, U.S. Patent and Trademark Office, Washington, DC 20231. DO NOT SEND FEES OR COMPLETED FORMS TO THIS ADDRESS. SEND TO: Assistant Commissioner for Patents, Washington, DC 20231.



UNITED STATES PATENT AND TRADEMARK OFFICE

Commissioner for Patents  
United States Patent and Trademark Office  
Washington, D.C. 20231  
www.uspto.gov

Paper No. 11

WESTVACO CORPORATION  
5255 VIRGINIA AVENUE  
P O BOX 118005  
CHARLESTON, SC 29423-8005

COPY MAILED

DEC 11 2002

OFFICE OF PETITIONS

In re Application of :  
Laurence H. Hiltzik et al :  
Application No. 10/100,362 :  
Filed: March 18, 2002 :  
Attorney Docket No. CHR 2001-79 :

ON PETITION

This is a decision on the petition, filed by facsimile transmission on December 11, 2002, under 37 CFR 1.313(c)(2) to withdraw the above-identified application from issue after payment of the issue fee.

The petition is **GRANTED**.

The above-identified application is withdrawn from issue for consideration of a submission under 37 CFR 1.114 (request for continued examination). See 37 CFR 1.313(c)(2).

**Petitioner is advised that the issue fee paid on November 19, 2002 in the above-identified application cannot be refunded. If, however, the above-identified application is again allowed, petitioner may request that it be applied towards the issue fee required by the new Notice of Allowance.<sup>1</sup>**

Telephone inquiries should be directed to the undersigned at (703) 305-8680.

Upon receipt of the file in the Office of Petitions, the file will be forwarded to Technology Center AU 1724 for processing of the request for continued examination under 37 CFR 1.114 and for consideration of the concurrently filed Information Disclosure Statement.

Frances Hicks  
Petitions Examiner  
Office of Petitions  
Office of the Deputy Commissioner  
for Patent Examination Policy

<sup>1</sup> The request to apply the issue fee to the new Notice must be made in writing and should be accompanied by the new Issue Fee Transmittal Form PTOL-85(b), along with a copy of this decision. Additionally, if the issue fee has increased from the previously paid issue fee, the balance due must be submitted. **Failure to *timely request in writing* that the previously paid issue fee be applied towards the new Notice and payment of any balance due will result in the abandonment of the application.**



UNITED STATES PATENT AND TRADEMARK OFFICE

UNITED STATES DEPARTMENT OF COMMERCE
United States Patent and Trademark Office
Address: COMMISSIONER OF PATENTS AND TRADEMARKS
Washington, D.C. 20231
www.uspto.gov

NOTICE OF ALLOWANCE AND FEE(S) DUE

7590 01/27/2003
Westvaco Corporation
5255 Virginia Avenue
P.O. Box 118005
Charleston, SC 29423-8005

EXAMINER
LAWRENCE JR, FRANK M
ART UNIT CLASS-SUBCLASS
1724 095-146000

DATE MAILED: 01/27/2003

Table with 5 columns: APPLICATION NO., FILING DATE, FIRST NAMED INVENTOR, ATTORNEY DOCKET NO., CONFIRMATION NO.

TITLE OF INVENTION: METHOD FOR REDUCING EMISSIONS FROM EVAPORATIVE EMISSIONS CONTROL SYSTEMS

Table with 6 columns: APPLN. TYPE, SMALL ENTITY, ISSUE FEE, PUBLICATION FEE, TOTAL FEE(S) DUE, DATE DUE

THE APPLICATION IDENTIFIED ABOVE HAS BEEN EXAMINED AND IS ALLOWED FOR ISSUANCE AS A PATENT. PROSECUTION ON THE MERITS IS CLOSED. THIS NOTICE OF ALLOWANCE IS NOT A GRANT OF PATENT RIGHTS. THIS APPLICATION IS SUBJECT TO WITHDRAWAL FROM ISSUE AT THE INITIATIVE OF THE OFFICE OR UPON PETITION BY THE APPLICANT. SEE 37 CFR 1.313 AND MPEP 1308.

THE ISSUE FEE AND PUBLICATION FEE (IF REQUIRED) MUST BE PAID WITHIN THREE MONTHS FROM THE MAILING DATE OF THIS NOTICE OR THIS APPLICATION SHALL BE REGARDED AS ABANDONED. THIS STATUTORY PERIOD CANNOT BE EXTENDED. SEE 35 U.S.C. 151. THE ISSUE FEE DUE INDICATED ABOVE REFLECTS A CREDIT FOR ANY PREVIOUSLY PAID ISSUE FEE APPLIED IN THIS APPLICATION. THE PTOL-85B (OR AN EQUIVALENT) MUST BE RETURNED WITHIN THIS PERIOD EVEN IF NO FEE IS DUE OR THE APPLICATION WILL BE REGARDED AS ABANDONED.

HOW TO REPLY TO THIS NOTICE:

I. Review the SMALL ENTITY status shown above.

If the SMALL ENTITY is shown as YES, verify your current SMALL ENTITY status:
A. If the status is the same, pay the TOTAL FEE(S) DUE shown above.
B. If the status is changed, pay the PUBLICATION FEE (if required) and twice the amount of the ISSUE FEE shown above and notify the United States Patent and Trademark Office of the change in status, or

If the SMALL ENTITY is shown as NO:
A. Pay TOTAL FEE(S) DUE shown above, or
B. If applicant claimed SMALL ENTITY status before, or is now claiming SMALL ENTITY status, check the box below and enclose the PUBLICATION FEE and 1/2 the ISSUE FEE shown above.
[ ] Applicant claims SMALL ENTITY status. See 37 CFR 1.27.

II. PART B - FEE(S) TRANSMITTAL should be completed and returned to the United States Patent and Trademark Office (USPTO) with your ISSUE FEE and PUBLICATION FEE (if required). Even if the fee(s) have already been paid, Part B - Fee(s) Transmittal should be completed and returned. If you are charging the fee(s) to your deposit account, section "4b" of Part B - Fee(s) Transmittal should be completed and an extra copy of the form should be submitted.

III. All communications regarding this application must give the application number. Please direct all communications prior to issuance to Box ISSUE FEE unless advised to the contrary.

IMPORTANT REMINDER: Utility patents issuing on applications filed on or after Dec. 12, 1980 may require payment of maintenance fees. It is patentee's responsibility to ensure timely payment of maintenance fees when due.

**PART B - FEE(S) TRANSMITTAL**

Complete and send this form, together with applicable fee(s), to: **Mail** Box ISSUE FEE  
**Commissioner for Patents**  
**Washington, D.C. 20231**  
**Fax (703)746-4000**

INSTRUCTIONS: This form should be used for transmitting the ISSUE FEE and PUBLICATION FEE (if required). Blocks 1 through 4 should be completed where appropriate. All further correspondence including the Patent, advance orders and notification of maintenance fees will be mailed to the current correspondence address as indicated unless corrected below or directed otherwise in Block 1, by (a) specifying a new correspondence address; and/or (b) indicating a separate "FEE ADDRESS" for maintenance fee notifications.

CURRENT CORRESPONDENCE ADDRESS (Note: Legibly mark-up with any corrections or use Block 1)  
 7590 01/27/2003

Westvaco Corporation  
 5255 Virginia Avenue  
 P.O. Box 118005  
 Charleston, SC 29423-8005

Note: A certificate of mailing can only be used for domestic mailings of the Fee(s) Transmittal. This certificate cannot be used for any other accompanying papers. Each additional paper, such as an assignment or formal drawing, must have its own certificate of mailing or transmission.

**Certificate of Mailing or Transmission**

I hereby certify that this Fee(s) Transmittal is being deposited with the United States Postal Service with sufficient postage for first class mail in an envelope addressed to the Box Issue Fee address above, or being facsimile transmitted to the USPTO, on the date indicated below.

(Depositor's name)
(Signature)
(Date)

APPLICATION NO.	FILING DATE	FIRST NAMED INVENTOR	ATTORNEY DOCKET NO.	CONFIRMATION NO.
10/100,362	03/18/2002	Laurence H. Hiltzik	CHR 2001-79	3899

TITLE OF INVENTION: METHOD FOR REDUCING EMISSIONS FROM EVAPORATIVE EMISSIONS CONTROL SYSTEMS

APPLN. TYPE	SMALL ENTITY	ISSUE FEE	PUBLICATION FEE	TOTAL FEE(S) DUE	DATE DUE
nonprovisional	NO	\$20	\$0	\$20	04/28/2003

EXAMINER	ART UNIT	CLASS-SUBCLASS
LAWRENCE JR, FRANK M	1724	095-146000

1. Change of correspondence address or indication of "Fee Address" (37 CFR 1.363). <input type="checkbox"/> Change of correspondence address (or Change of Correspondence Address form PTO/SB/122) attached. <input type="checkbox"/> "Fee Address" indication (or "Fee Address" Indication form PTO/SB/47; Rev 03-02 or more recent) attached. Use of a Customer Number is required.	2. For printing on the patent front page, list (1) the names of up to 3 registered patent attorneys or agents OR, alternatively, (2) the name of a single firm (having as a member a registered attorney or agent) and the names of up to 2 registered patent attorneys or agents. If no name is listed, no name will be printed. 1 _____ 2 _____ 3 _____
---	--

3. ASSIGNEE NAME AND RESIDENCE DATA TO BE PRINTED ON THE PATENT (print or type)  
 PLEASE NOTE: Unless an assignee is identified below, no assignee data will appear on the patent. Inclusion of assignee data is only appropriate when an assignment has been previously submitted to the USPTO or is being submitted under separate cover. Completion of this form is NOT a substitute for filing an assignment.  
 (A) NAME OF ASSIGNEE \_\_\_\_\_ (B) RESIDENCE: (CITY and STATE OR COUNTRY) \_\_\_\_\_

Please check the appropriate assignee category or categories (will not be printed on the patent)  individual  corporation or other private group entity  government

4a. The following fee(s) are enclosed: <input type="checkbox"/> Issue Fee <input type="checkbox"/> Publication Fee <input type="checkbox"/> Advance Order - # of Copies _____	4b. Payment of Fee(s): <input type="checkbox"/> A check in the amount of the fee(s) is enclosed. <input type="checkbox"/> Payment by credit card. Form PTO-2038 is attached. <input type="checkbox"/> The Commissioner is hereby authorized by charge the required fee(s), or credit any overpayment, to Deposit Account Number _____ (enclose an extra copy of this form).
--	--

Commissioner for Patents is requested to apply the Issue Fee and Publication Fee (if any) or to re-apply any previously paid issue fee to the application identified above.

(Authorized Signature)	(Date)
NOTE: The Issue Fee and Publication Fee (if required) will not be accepted from anyone other than the applicant; a registered attorney or agent; or the assignee or other party in interest as shown by the records of the United States Patent and Trademark Office. This collection of information is required by 37 CFR 1.311. The information is required to obtain or retain a benefit by the public which is to file (and by the USPTO to process) an application. Confidentiality is governed by 35 U.S.C. 122 and 37 CFR 1.14. This collection is estimated to take 12 minutes to complete, including gathering, preparing, and submitting the completed application form to the USPTO. Time will vary depending upon the individual case. Any comments on the amount of time you require to complete this form and/or suggestions for reducing this burden, should be sent to the Chief Information Officer, U.S. Patent and Trademark Office, U.S. Department of Commerce, Washington, D.C. 20231. DO NOT SEND FEES OR COMPLETED FORMS TO THIS ADDRESS. SEND TO: Commissioner for Patents, Washington, DC 20231. Under the Paperwork Reduction Act of 1995, no persons are required to respond to a collection of information unless it displays a valid OMB control number.	

TRANSMIT THIS FORM WITH FEE(S)





UNITED STATES PATENT AND TRADEMARK OFFICE

UNITED STATES DEPARTMENT OF COMMERCE  
United States Patent and Trademark Office  
Address: COMMISSIONER OF PATENTS AND TRADEMARKS  
Washington, D.C. 20231  
www.uspto.gov

APPLICATION NO.	FILING DATE	FIRST NAMED INVENTOR	ATTORNEY DOCKET NO.	CONFIRMATION NO.
-----------------	-------------	----------------------	---------------------	------------------

10/100,362

03/18/2002

Laurence H. Hiltzik

CHR 2001-79

3899

7590

01/27/2003

EXAMINER

LAWRENCE JR, FRANK M

Westvaco Corporation  
5255 Virginia Avenue  
P.O. Box 118005  
Charleston, SC 29423-8005

ART UNIT

PAPER NUMBER

1724

DATE MAILED: 01/27/2003

**Determination of Patent Term Adjustment under 35 U.S.C. 154 (b)**  
(application filed on or after May 29, 2000)

The patent term adjustment to date is 0 days. If the issue fee is paid on the date that is three months after the mailing date of this notice and the patent issues on the Tuesday before the date that is 28 weeks (six and a half months) after the mailing date of this notice, the term adjustment will be 0 days.

If a continued prosecution application (CPA) was filed in the above-identified application, the filing date that determines patent term adjustment is the filing date of the most recent CPA.

Applicant will be able to obtain more detailed information by accessing the Patent Application Information Retrieval (PAIR) system. (<http://pair.uspto.gov>)

Any questions regarding the patent term extension or adjustment determination should be directed to the Office of Patent Legal Administration at (703)305-1383.



UNITED STATES PATENT AND TRADEMARK OFFICE

UNITED STATES DEPARTMENT OF COMMERCE  
United States Patent and Trademark Office  
Address: COMMISSIONER OF PATENTS AND TRADEMARKS  
Washington, D.C. 20231  
www.uspto.gov

APPLICATION NO.	FILING DATE	FIRST NAMED INVENTOR	ATTORNEY DOCKET NO.	CONFIRMATION NO.
-----------------	-------------	----------------------	---------------------	------------------

10/100,362	03/18/2002	Laurence H. Hiltzik	CHR 2001-79	3899
------------	------------	---------------------	-------------	------

7590	01/27/2003			
------	------------	--	--	--

Westvaco Corporation  
5255 Virginia Avenue  
P.O. Box 118005  
Charleston, SC 29423-8005  
UNITED STATES

EXAMINER
----------

LAWRENCE JR, FRANK M

ART UNIT	PAPER NUMBER
----------	--------------

1724

DATE MAILED: 01/27/2003

**Notice of Fee Increase on January 1, 2003**

If a reply to a "Notice of Allowance and Fee(s) Due" is filed in the Office on or after January 1, 2003, then the amount due will be higher than that set forth in the "Notice of Allowance and Fee(s) Due" since there will be an increase in fees effective on January 1, 2003. See Revision of Patent and Trademark Fees for Fiscal Year 2003; Final Rule, 67 Fed. Reg. 70847, 70849 (November 27, 2002).

The current fee schedule is accessible from: <http://www.uspto.gov/main/howtofees.htm>.

If the issue fee paid is the amount shown on the "Notice of Allowance and Fee(s) Due," but not the correct amount in view of the fee increase, a "Notice to Pay Balance of Issue Fee" will be mailed to applicant. In order to avoid processing delays associated with mailing of a "Notice to Pay Balance of Issue Fee," if the response to the Notice of Allowance and Fee(s) due form is to be filed on or after January 1, 2003 (or mailed with a certificate of mailing on or after January 1, 2003), the issue fee paid should be the fee that is required at the time the fee is paid. If the issue fee was previously paid, and the response to the "Notice of Allowance and Fee(s) Due" includes a request to apply a previously-paid issue fee to the issue fee now due, then the difference between the issue fee amount at the time the response is filed and the previously paid issue fee should be paid. See Manual of Patent Examining Procedure, Section 1308.01 (Eighth Edition, August 2001).

Questions relating to issue and publication fee payments should be directed to the Customer Service Center of the Office of Patent Publication at (703) 305-8283.

AS-12

<b>Notice of Allowability</b>	<b>Application No.</b>	<b>Applicant(s)</b>	
	10/100,362	HILTZIK ET AL.	
	<b>Examiner</b>	<b>Art Unit</b>	
	Frank M. Lawrence	1724	

-- The MAILING DATE of this communication appears on the cover sheet with the correspondence address--  
 All claims being allowable, PROSECUTION ON THE MERITS IS (OR REMAINS) CLOSED in this application. If not included herewith (or previously mailed), a Notice of Allowance (PTOL-85) or other appropriate communication will be mailed in due course. THIS NOTICE OF ALLOWABILITY IS NOT A GRANT OF PATENT RIGHTS. This application is subject to withdrawal from issue at the initiative of the Office or upon petition by the applicant. See 37 CFR 1.313 and MPEP 1308.

- 1.  This communication is responsive to the RCE and IDS filed December 11, 2002.
- 2.  The allowed claim(s) is/are 1-30.
- 3.  The drawings filed on 18 March 2002 are accepted by the Examiner.
- 4.  Acknowledgment is made of a claim for foreign priority under 35 U.S.C. § 119(a)-(d) or (f).
  - a)  All    b)  Some\*    c)  None    of the:
    - 1.  Certified copies of the priority documents have been received.
    - 2.  Certified copies of the priority documents have been received in Application No. \_\_\_\_\_.
    - 3.  Copies of the certified copies of the priority documents have been received in this national stage application from the International Bureau (PCT Rule 17.2(a)).
- \* Certified copies not received: \_\_\_\_\_.
- 5.  Acknowledgment is made of a claim for domestic priority under 35 U.S.C. § 119(e) (to a provisional application).
  - (a)  The translation of the foreign language provisional application has been received.
- 6.  Acknowledgment is made of a claim for domestic priority under 35 U.S.C. §§ 120 and/or 121.

Applicant has THREE MONTHS FROM THE "MAILING DATE" of this communication to file a reply complying with the requirements noted below. Failure to timely comply will result in ABANDONMENT of this application. THIS THREE-MONTH PERIOD IS NOT EXTENDABLE.

- 7.  A SUBSTITUTE OATH OR DECLARATION must be submitted. Note the attached EXAMINER'S AMENDMENT or NOTICE OF INFORMAL PATENT APPLICATION (PTO-152) which gives reason(s) why the oath or declaration is deficient.
- 8.  CORRECTED DRAWINGS must be submitted.
  - (a)  including changes required by the Notice of Draftsperson's Patent Drawing Review (PTO-948) attached
    - 1)  hereto or 2)  to Paper No. \_\_\_\_\_.
  - (b)  including changes required by the proposed drawing correction filed \_\_\_\_\_, which has been approved by the Examiner.
  - (c)  including changes required by the attached Examiner's Amendment / Comment or in the Office action of Paper No. \_\_\_\_\_.

Identifying indicia such as the application number (see 37 CFR 1.84(c)) should be written on the drawings in the top margin (not the back) of each sheet. The drawings should be filed as a separate paper with a transmittal letter addressed to the Official Draftsperson.

- 9.  DEPOSIT OF and/or INFORMATION about the deposit of BIOLOGICAL MATERIAL must be submitted. Note the attached Examiner's comment regarding REQUIREMENT FOR THE DEPOSIT OF BIOLOGICAL MATERIAL.

**Attachment(s)**

- 1  Notice of References Cited (PTO-892)
- 2  Notice of Informal Patent Application (PTO-152)
- 3  Notice of Draftsperson's Patent Drawing Review (PTO-948)
- 4  Interview Summary (PTO-413), Paper No. \_\_\_\_\_
- 5  Information Disclosure Statements (PTO-1449), Paper No. 8.
- 6  Examiner's Amendment/Comment
- 7  Examiner's Comment Regarding Requirement for Deposit of Biological Material
- 8  Examiner's Statement of Reasons for Allowance
- 9  Other

Application/Control Number: 10/100,362  
Art Unit: 1724

Page 2

### **DETAILED ACTION**

#### *Allowable Subject Matter*

1. Claims 1-30 are allowed.
2. The following is an examiner's statement of reasons for allowance: Reasons for allowance are given in the office action of paper no. 7. The newly submitted information disclosure statement has been considered and the instant claims remain allowable over the cited references because none of the references suggests using sorbents having the butane working capacities recited in the independent claims.

Any comments considered necessary by applicant must be submitted no later than the payment of the issue fee and, to avoid processing delays, should preferably accompany the issue fee. Such submissions should be clearly labeled "Comments on Statement of Reasons for Allowance."

#### *Conclusion*

3. The prior art made of record and not relied upon is considered pertinent to applicant's disclosure. The reference to Tolles et al. (5,238,470) discloses sorbents for emission control having high butane working capacities.

Any inquiry concerning this communication or earlier communications from the examiner should be directed to Frank M. Lawrence whose telephone number is 703-305-0585. The examiner can normally be reached on Mon-Thurs 7:30-5:00; alternate Fridays 7:00-4:00.

If attempts to reach the examiner by telephone are unsuccessful, the examiner's supervisor, David A. Simmons can be reached on 703-308-1972. The fax phone numbers for the

Application/Control Number: 10/100,362

Page 3

Art Unit: 1724

organization where this application or proceeding is assigned are 703-872-9310 for regular communications and 703-872-9311 for After Final communications.

Any inquiry of a general nature or relating to the status of this application or proceeding should be directed to the receptionist whose telephone number is 703-308-0651.

fl

12  
January 14, 2003



David A. Simmons  
Supervisory Patent Examiner  
Technology Center 1700

**Notice of References Cited**

Application/Control No.  
10/100,362

Applicant(s)/Patent Under  
Reexamination  
HILTZIK ET AL.

Examiner  
Frank M. Lawrence

Art Unit  
1724

Page 1 of 1

**U.S. PATENT DOCUMENTS**

*		Document Number Country Code-Number-Kind Code	Date MM-YYYY	Name	Classification
*	A	US-5238470	08-1993	Tolles et al	95/143
	B	US-			
	C	US-			
	D	US-			
	E	US-			
	F	US-			
	G	US-			
	H	US-			
	I	US-			
	J	US-			
	K	US-			
	L	US-			
	M	US-			

**FOREIGN PATENT DOCUMENTS**

*		Document Number Country Code-Number-Kind Code	Date MM-YYYY	Country	Name	Classification
	N					
	O					
	P					
	Q					
	R					
	S					
	T					

**NON-PATENT DOCUMENTS**

*		Include as applicable: Author, Title Date, Publisher, Edition or Volume, Pertinent Pages)
	U	
	V	
	W	
	X	

\*A copy of this reference is not being furnished with this Office action. (See MPEP § 707.05(a).)  
Dates in MM-YYYY format are publication dates. Classifications may be US or foreign.

Sent By: CTC;

8437468494;

Feb-3-03 1:06PM;

Page 1/2

B \$

PART B - FEE(S) TRANSMITTAL

Complete and send this form, together with applicable fee(s), to: Mail Box ISSUE FEE
Commissioner for Patents
Washington, D.C. 20231
Fax (703)746-4000

INSTRUCTIONS: This form should be used for transmitting the ISSUE FEE and PUBLICATION FEE (if required). Blocks 1 through 4 should be completed where appropriate. All further correspondence including the Patent, advance orders and notification of maintenance fees will be mailed to the current correspondence address as indicated unless corrected below or directed otherwise in Block 1, by (a) specifying a new correspondence address, and/or (b) indicating a separate "FEE ADDRESS" for maintenance fee notifications.

CURRENT CORRESPONDENCE ADDRESS (Note: Legibly mark-up with any corrections of this block 1)
7590 01/27/2003

Westvaco Corporation
5255 Virginia Avenue
P.O. Box 118005
Charleston, SC 29423-8005



Note: A certificate of mailing can only be used for domestic mailings of the Fee(s) Transmittal. This certificate cannot be used for any other accompanying papers. Each additional paper, such as an assignment or formal drawing, must have its own certificate of mailing or transmission.

Certificate of Mailing or Transmission
I hereby certify that this Fee(s) Transmittal is being deposited with the United States Postal Service with sufficient postage for first class mail in an envelope addressed to the Box Issue Fee address above, or being facsimile transmitted to the USPTO, on the date indicated below.

Susan C. Harrison (Depositor's name)
Susan C. Harrison (Signature)
February 3, 2003 (Date)

Table with 5 columns: APPLICATION NO., FILING DATE, FIRST NAMED INVENTOR, ATTORNEY DOCKET NO., CONFIRMATION NO.
Values: 10/100,362, 03/18/2002, Lawrence H. Hiltzik, CHR 2001-79, 3899

TITLE OF INVENTION: METHOD FOR REDUCING EMISSIONS FROM EVAPORATIVE EMISSIONS CONTROL SYSTEMS

Table with 6 columns: APPLN. TYPE, SMALL ENTITY, ISSUE FEE, PUBLICATION FEE, TOTAL FEE(S) DUE, DATE DUE
Values: nonprovisional, NO, \$20, \$0, \$20, 04/28/2003

Table with 3 columns: EXAMINER, ART. UNIT, CLASS-SUBCLASS
Values: LAWRENCE JR, FRANK M, 1724, 095-146000

- 1. Change of correspondence address or indication of "Fee Address" (37 CFR 1.363).
2. For printing on the patent front page, list (1) the names of up to 3 registered patent attorneys or agents OR, alternatively, (2) the name of a single firm...
Terry B. McDaniel
Daniel B. Reece IV
Thomas A. Boshinski

3. ASSIGNEE NAME AND RESIDENCE DATA TO BE PRINTED ON THE PATENT (print or type)
PLEASE NOTE: Unless an assignee is identified below, no assignee data will appear on the patent. Inclusion of assignee data is only appropriate when an assignment has been previously submitted to the USPTO or is being submitted under separate cover. Completion of this form is NOT a substitute for filing an assignment.
(A) NAME OF ASSIGNEE (B) RESIDENCE: (CITY and STATE OR COUNTRY)

MeadWestvaco Corporation Stamford, Connecticut

Please check the appropriate assignee category or categories (will not be printed on the patent)
Individual Corporation or other private group entity Government

- 4a. The following fee(s) are enclosed:
4b. Payment of Fee(s):
A check in the amount of the fee(s) is enclosed.
Payment by credit card. Form PFO-2038 is attached.
The Commissioner is hereby authorized by charge the required fee(s), or credit any overpayment, to Deposit Account Number 23-1160 (enclose an extra copy of this form).

Commissioner for Patents is requested to apply the Issue Fee and Publication Fee (if any) or to re-apply any previously paid issue fee to the application identified above.
Check No. 002254028 in the amount of \$1610.00 mailed on 11/14/02

Authorized Signature (Date)
1/31/03

Adjustment date: 02/05/2003 NBERHE1
11/21/2002 NBERHE1 00000091 10100362
01 FC:1501 -1280.00 DP

NOTE: The Issue Fee and Publication Fee (if required) will not be accepted from anyone other than the applicant, a registered attorney or agent, or the assignee or other party in interest as shown by the records of the United States Patent and Trademark Office.
This collection of information is required by 37 CFR 1.311. The information is required to obtain or retain a benefit by the public which is to file (and by the USPTO to process) an application. Confidentiality is governed by 35 U.S.C. 122 and 37 CFR 1.14. This collection is estimated to take 12 minutes to complete, including gathering, preparing, and submitting the completed application form to the USPTO. Time will vary depending upon the individual case. Any comments on the amount of time you require to complete this form and/or suggestions for reducing this burden, should be sent to the Chief Information Officer, U.S. Patent and Trademark Office, U.S. Department of Commerce, Washington, D.C. 20231. DO NOT SEND FEES OR COMPLETED FORMS TO THIS ADDRESS. SEND TO: Commissioner for Patents, Washington, DC 20231.

02/05/2003 NBERHE1 00000020 231160 10100362
01 FC:1501 20.00 CH 1280.00 DP

Under the Paperwork Reduction Act of 1995, no persons are required to respond to a collection of information unless it displays a valid OMB control number. TRANSMIT THIS FORM WITH FEE(S)

PTOL-85 (REV. 04-02) Approved for use through 01/31/2004. OMB 0651-0033 U.S. Patent and Trademark Office; U.S. DEPARTMENT OF COMMERCE

Received from < 8437468494 > at 2/3/03 1:02:44 PM [Eastern Standard Time]

APPROVED	O.G. FIG. 2	
BY	CLASS	SUBCLASS
DRAFTSMAN	95	146

6540815

FIGURE 1  
PRIOR ART

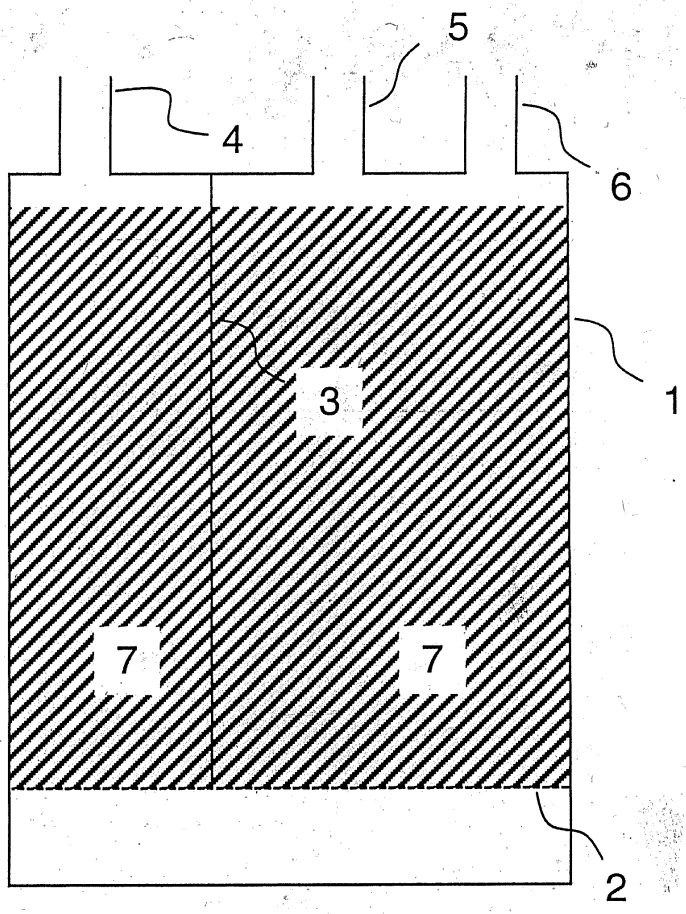

10100352-031802



APPROVED	O.G. FIG. 2	
BY	CLASS	SUBCLASS
DRAFTSMAN	95	146

FIGURE 2

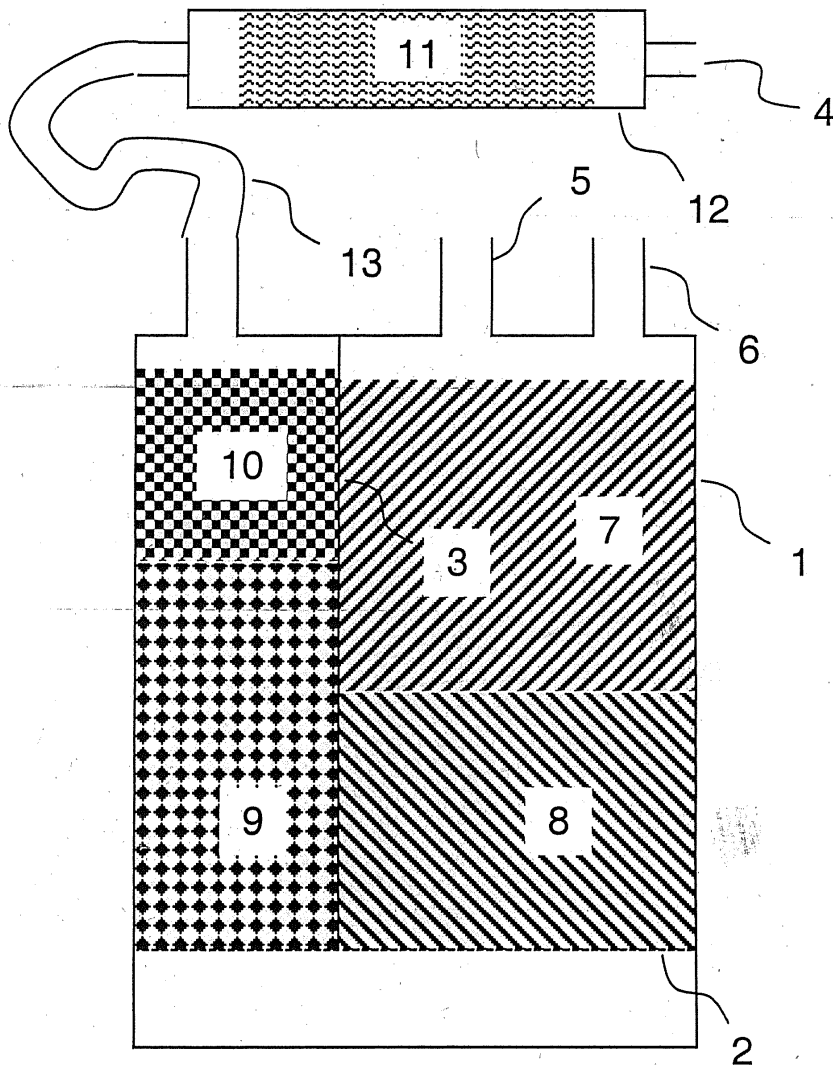

10100352-031602

APPROVED	C.S. No. 2	
BY	CLASS	SUBCLASS
DRAFTSMAN	95	146

FIGURE 3

n-Butane Adsorption Isotherm at 25°C

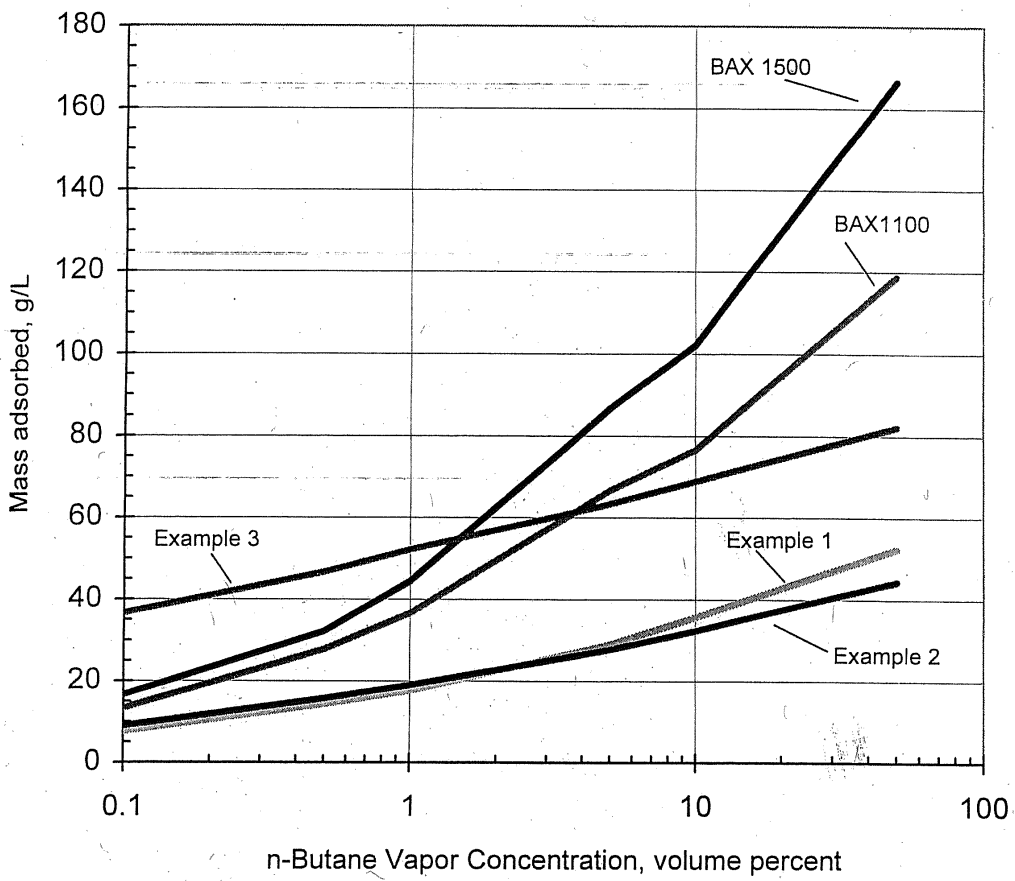

10100369-0180

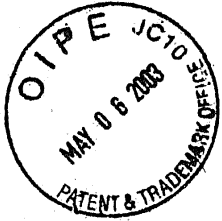

Case Docket No. CHR 2001-79

IN THE UNITED STATES PATENT AND TRADEMARK OFFICE

Applicants: Laurence H. Hiltzik, Jacek Z. Jagiello, Edward D. Tolles, and Roger S. Williams

Patent No.: 6,540,815 B1

Serial No.: 10/100,362

Group Art Unit: 1724

Issued: April 1, 2003

For: METHOD FOR REDUCING EMISSIONS FROM EVAPORATIVE EMISSIONS  
CONTROL SYSTEMS

Honorable Commissioner of  
Patents and Trademarks  
Washington, DC 20231

**Certificate**  
**MAY 12 2003**  
**of Correction**

REQUEST FOR CERTIFICATE OF CORRECTION  
UNDER RULE 322

Dear Sir:

In accordance with the provisions of Rule 322 of the Rules of Practice, which implement 35 U.S.C. 254, the Patent and Trademark Office is requested to issue a Certificate of Correction in the above-identified patent, to show the corrections set forth on the attached Patent and Trademark Office Form PTO-1050.

Since these mistakes were the fault of the Patent and Trademark Office, it is believed to be in order for the Patent and Trademark Office to issue a Certificate of Correction on the enclosed patent document and to place such a Certificate of Correction in the file, so that such will appear on any copies of the patent which are ordered in the future. Moreover, since these mistakes are those of the Patent and Trademark Office, such should be done without charge to the patentee or assignee.

Case Docket No. CHR 2001-79

It is respectfully requested that when the above-requested Certificate of Correction has been completed and entered on the formal patent document, as well as in the file, that a duly authenticated Certificate of Correction be returned to the Attorney of Record.

Respectfully submitted,

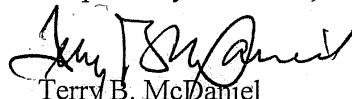

Terry B. McDaniel  
Attorney for the Applicant  
Registration No. 28,444

TBM/sch  
Enclosure  
Dated: May 1, 2003  
5255 Virginia Avenue  
P. O. Box 118005  
Charleston, SC 29423-8005  
(843) 746-8493



*C of C*  
*# 13*

Case Docket No. CHR 2001-79  
Patent No. 6,540,815 B1

*R*

CERTIFICATE UNDER 37 C.F.R. 1.8(a)

I hereby certify that this correspondence is being deposited with the United States Postal Service as first class mail in an envelope addressed to the Commissioner for Patents, Alexandria, VA 22313-1450, on May 2, 2003.

*Susan C. Harrison*  
Susan C. Harrison

*BS*  
Certificate  
~~MAY 12 2003~~  
of Correction

MAY 12 2003

Case Docket No. CHR 2001-79

PTO/SB/44 (02-01)

Approved for use through 01/31/2004. OMB 0651-0033  
U.S. Patent and Trademark Office; U.S. DEPARTMENT OF COMMERCE

Under the Paperwork Reduction Act of 1995, no persons are required to respond to a collection of information unless it displays a valid OMB control number.  
(Also Form PTO-1050)

**UNITED STATES PATENT AND TRADEMARK OFFICE  
CERTIFICATE OF CORRECTION**

PATENT NO.: 6,540,815 B1

DATED: April 1, 2003

INVENTOR(S): Laurence H. Hiltzik, <sup>et al.</sup> Jacek Z. Jagiello, Edward D. Tolles, and Roger S. Williams

It is certified that error appears in the above-identified patent and that said Letters Patent is hereby corrected as shown below:

On the title page, in the References Cited, page 2, insert ~~the~~ <sup>U.S. PATENT DOCUMENTS,</sup>

-- 5,957,114 9/1999 Johnson et al.  
6,078,601 8/2000 Reddy --.

<sup>6,098,601</sup>  
In the drawings, Sheet 1, beneath Figure 1 delete "Prior Art."

In Column 8, Table 1, Footnote 1, delete "Test" and insert therefor --Tests--.

MAILING ADDRESS OF SENDER:  
MeadWestvaco Corporation  
5255 Virginia Avenue  
P.O. Box 118005  
Charleston, SC 29423-8005

PATENT NO. 6,540,815 B1

No. of additional copies



Burden Hour Statement: This form is estimated to take 1.0 hour to complete. Time will vary depending upon the needs of the individual case. Any comment on the amount of time you are required to complete this form should be sent to the Chief Information Officer, U.S. Patent and Trademark Office, Washington, DC 20231.

DO NOT SEND FEES OR COMPLETED FORMS TO THIS ADDRESS. SEND TO: Assistant Commissioner for Patents, Washington, DC 20231.

NOTICE RE: CERTIFICATES OF CORRECTION

DATE : 7/16/03

Paper No.: \_\_\_\_\_

TO : Supervisor, Art Unit 1724

#14  
#12

SUBJECT : Certificate of Correction Request in Patent No.: 6540815

A response to the following question is requested with respect to the accompanying request for a certificate of correction.

With respect to the change(s) requested, correcting Office and/or Applicant's errors, should the pater read as shown in the certificate of correction? No new matter should be introduced, nor should the scope or meaning of the claims be changed.

Was the reference entered or is this new matter with the reference want to be entered because its not stated in the references.

*[Handwritten signature]*

PLEASE COMPLETE THIS FORM AND RETURN WITH FILE, WITHIN 7 DAYS, TO CERTIFICATES OF CORRECTION BRANCH - PK 3-915/922 PALM LOCATION 7580 - TEL. NO. 305-8309

THANK YOU FOR YOUR ASSISTANCE!

Note your decision, regarding the changes requested in the Request for Certificate of Correction, by placing a check mark (✓) in the box that reflects your decision, which corresponds to the question checked above.

YES  NO  Comments below

Comments: The references were not considered by the examiner. The attorney was notified by phone that they were not considered and wouldnt be entered on the c. of C.  
FL

*[Handwritten signature]*  
BLAINE COPENHEAVER  
SUPERVISORY PATENT EXAMINER  
TECHNOLOGY CENTER 1700

1724  
Art Unit



UNITED STATES PATENT AND TRADEMARK OFFICE

COMMISSIONER FOR PATENTS  
UNITED STATES PATENT AND TRADEMARK OFFICE  
P.O. Box 1450  
ALEXANDRIA, VA 22313-1450  
www.uspto.gov

Date Mailed :

Patent No. : 6540815

Inventor(s) : Hiltzik et al.

Patent Issued : 4/1/03

Title : METHOD FOR REDUCING EMISSIONS FROM EVAPORATIVE  
EMISSIONS CONTROL SYSTEM

Docket No. :

~~11/15~~  
11/15

Re: Request for Certificate of Correction

Consideration has been given your request for the issuance of a certificate of correction for the above-identified patent under the provisions of Rule(s) ....

Inspection of the patent application file reveals , that the alleged error(s) in the references were not considered by the examiner. The attorney was notified by phone that they were not considered and wouldn't be entered on the C of C. Therefore, no fault on the part of the Patent and Trademark Office, has no authority to issue a certificate of correction under the provisions of 35 U.S.C. 254 and rules of Practice of the United States Patent and Trademark Office in Patent Cases.

A certificate of correction will issue to correct the remaining errors noted in your request.

In view of the foregoing, your request in these/this matter, is hereby denied. However, further consideration will be given upon receipt of a Request for Reconsideration , which should be directed to Decisions and Certificate of Correction Branch. Requests for Reconsideration should be accompanied by additional support (e.g. copy of amendments , post card receipts. PTOL 1449 or 892 , etc.) , containing requested data or changes) and / or brief statements of facts , as requested.

Henry D. Randall  
Decision and Certificate of Corrections  
(703) 306 - 2817



Cecelia Newman , Supervisor  
Decision and Certificates of Correction  
(703) 305 – 8309

Meadwestvaco Corporation  
5255 Virginia Avenue  
P.O. Box 118005  
Charleston, SC 29423-8005

CBN/hr

UNITED STATES PATENT AND TRADEMARK OFFICE  
**CERTIFICATE OF CORRECTION**

PATENT NO. : 6,540,815 B1  
DATED : April 1, 2003  
INVENTOR(S) : Laurence H. Hiltzik et al.

Page 1 of 1

It is certified that error appears in the above-identified patent and that said Letters Patent is hereby corrected as shown below:

Title page,

Item [56], **References Cited**, U.S. PATENT DOCUMENTS, insert:

-- 5,957,114	9/1999	Johnson et al.
6,078,601	8/2000	Reddy --.

Drawings,

Sheet 1, beneath Figure 1 delete "Prior Art."

Column 8,

Table, Footnote 1, delete "Test" and insert therefor -- Tests --.

Signed and Sealed this

Twenty-sixth Day of August, 2003

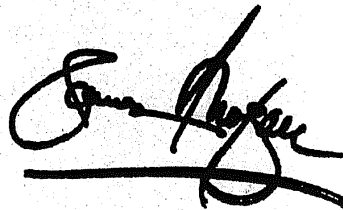

JAMES E. ROGAN  
*Director of the United States Patent and Trademark Office*

L Number	Hits	Search Text	DB	Time stamp
1	998	((95/90) or (95/146) or (95/148) or (95/900) or (95/901) or (95/902) or (95/903) or (96/132) or (96/133) or (96/147)).CCLS.	USPAT	2002/09/23 16:11
2	499	((123/518) or (123/519)).CCLS.	USPAT	2002/09/23 16:12
3	35	(95/90.ccls. or 95/146.ccls. or 95/148.ccls. or 95/900.ccls. or 95/901.ccls. 95/902.ccls. or 95/903.ccls. or 96/132.ccls. or 96/133.ccls. or 96/147.ccls. or 123/518.ccls. or 123/519.ccls. or 502/416.ccls.) and ((butane same capacity) or (diurnal adj breath\$3))	USPAT	2002/09/23 16:14
4	35	(95/90.ccls. or 95/146.ccls. or 95/148.ccls. or 95/900.ccls. or 95/901.ccls. 95/902.ccls. or 95/903.ccls. or 96/132.ccls. or 96/133.ccls. or 96/147.ccls. or 123/518.ccls. or 123/519.ccls. or 502/416.ccls.) and ((butane same capacity) or (diurnal adj breath\$3) or bwc)	USPAT	2002/09/23 16:41
5	0	(95/90.ccls. or 95/146.ccls. or 95/148.ccls. or 95/900.ccls. or 95/901.ccls. 95/902.ccls. or 95/903.ccls. or 96/132.ccls. or 96/133.ccls. or 96/147.ccls. or 123/518.ccls. or 123/519.ccls. or 502/416.ccls.) and ((butane same capacity) or (diurnal adj breath\$3) or bwc)	US-PGPUB	2002/09/23 16:42
6	0	(95/90.ccls. or 95/146.ccls. or 95/148.ccls. or 95/900.ccls. or 95/901.ccls. 95/902.ccls. or 95/903.ccls. or 96/132.ccls. or 96/133.ccls. or 96/147.ccls. or 123/518.ccls. or 123/519.ccls. or 502/416.ccls.) and dbl	US-PGPUB	2002/09/23 16:42
7	3	(95/90.ccls. or 95/146.ccls. or 95/148.ccls. or 95/900.ccls. or 95/901.ccls. 95/902.ccls. or 95/903.ccls. or 96/132.ccls. or 96/133.ccls. or 96/147.ccls. or 123/518.ccls. or 123/519.ccls. or 502/416.ccls.) and dbl	USPAT	2002/09/23 16:42
8	33	(96/132.ccls. or 96/133.ccls.) and ((fuel adj vapor) or canister or (evaporative adj emission) or gasoline)	USPAT	2002/09/23 16:48
9	40	(96/147.ccls.) and ((fuel adj vapor) or canister or (evaporative adj emission) or gasoline)	USPAT	2002/09/23 16:52
10	75	(95/146).CCLS.	USPAT	2002/09/23 17:12
11	499	((123/518) or (123/519)).CCLS.	USPAT	2002/09/23 17:12
12	15	(canister or (evaporative adj emission) or (fuel vapor)) and ((diurnal adj breath\$3) or dbl or (butane near5 capacity) or bwc)	EPO; JPO; DERWENT	2002/09/23 17:41
-	24	"5032042"	USPAT	2000/09/27 08:16
-	22	(("4677086") or ("5204310") or ("5206207") or ("5250491") or ("5276000") or ("5304527") or ("5324703") or ("5416056") or ("5538932") or ("5691270") or ("5736481") or ("5736485") or ("5863858") or ("5914294") or ("6136075") or ("6171373") or ("6284705") or ("5456236") or ("5456237") or ("5460136") or ("5477836") or ("4894072")).PN.	USPAT	2002/09/23 14:33

**PATENT APPLICATION FEE DETERMINATION RECORD**  
Effective October 1, 2001

Application or Docket Number  
*CMR 2001-79*

**CLAIMS AS FILED - PART I**

	(Column 1)	(Column 2)
TOTAL CLAIMS	<i>30</i>	
FOR	NUMBER FILED	NUMBER EXTRA
TOTAL CHARGEABLE CLAIMS	<i>30</i> minus 20= *	<i>10</i>
INDEPENDENT CLAIMS	<i>2</i> minus 3= *	<i>-</i>
MULTIPLE DEPENDENT CLAIM PRESENT <input type="checkbox"/>		

\* If the difference in column 1 is less than zero, enter "0" in column 2

**CLAIMS AS AMENDED - PART II**

	(Column 1)	(Column 2)	(Column 3)
<b>AMENDMENT A</b>	CLAIMS REMAINING AFTER AMENDMENT	HIGHEST NUMBER PREVIOUSLY PAID FOR	PRESENT EXTRA
	Total *	Minus **	=
	Independent *	Minus ***	=
FIRST PRESENTATION OF MULTIPLE DEPENDENT CLAIM <input type="checkbox"/>			

	(Column 1)	(Column 2)	(Column 3)
<b>AMENDMENT B</b>	CLAIMS REMAINING AFTER AMENDMENT	HIGHEST NUMBER PREVIOUSLY PAID FOR	PRESENT EXTRA
	Total *	Minus **	=
	Independent *	Minus ***	=
FIRST PRESENTATION OF MULTIPLE DEPENDENT CLAIM <input type="checkbox"/>			

	(Column 1)	(Column 2)	(Column 3)
<b>AMENDMENT C</b>	CLAIMS REMAINING AFTER AMENDMENT	HIGHEST NUMBER PREVIOUSLY PAID FOR	PRESENT EXTRA
	Total *	Minus **	=
	Independent *	Minus ***	=
FIRST PRESENTATION OF MULTIPLE DEPENDENT CLAIM <input type="checkbox"/>			

\* If the entry in column 1 is less than the entry in column 2, write "0" in column 3.  
 \*\* If the "Highest Number Previously Paid For" IN THIS SPACE is less than 20, enter "20."  
 \*\*\* If the "Highest Number Previously Paid For" IN THIS SPACE is less than 3, enter "3."  
 The "Highest Number Previously Paid For" (Total or Independent) is the highest number found in the appropriate box in column 1.

**SMALL ENTITY TYPE**  OR

RATE	FEE
BASIC FEE	370.00
X\$ 9=	
X42=	
+140=	
TOTAL	

**OTHER THAN SMALL ENTITY**

RATE	FEE
BASIC FEE	740.00
X\$18=	<i>180</i>
X84=	
+280=	
TOTAL	

**SMALL ENTITY TYPE**  OR

RATE	ADDITIONAL FEE
X\$ 9=	
X42=	
+140=	
TOTAL ADDIT. FEE	

**OTHER THAN SMALL ENTITY**

RATE	ADDITIONAL FEE
X\$18=	
X84=	
+280=	
TOTAL ADDIT. FEE	

**SMALL ENTITY TYPE**  OR

RATE	ADDITIONAL FEE
X\$ 9=	
X42=	
+140=	
TOTAL ADDIT. FEE	

**OTHER THAN SMALL ENTITY**

RATE	ADDITIONAL FEE
X\$18=	
X84=	
+280=	
TOTAL ADDIT. FEE	

**SMALL ENTITY TYPE**  OR

RATE	ADDITIONAL FEE
X\$ 9=	
X42=	
+140=	
TOTAL ADDIT. FEE	

**OTHER THAN SMALL ENTITY**

RATE	ADDITIONAL FEE
X\$18=	
X84=	
+280=	
TOTAL ADDIT. FEE	

# CLAIMS ONLY

SERIAL NO. 10100362 FILING DATE 03-18-02  
 APPLICANT(S)

## CLAIMS

	AS FILED		AFTER 1st AMENDMENT		AFTER 2nd AMENDMENT	
	IND.	DEP.	IND.	DEP.	IND.	DEP.
1	/		✓			
2		/				
3		/				
4		/				
5		/				
6		/				
7		/				
8		/				
9		/				
10		/				
11		/				
12		/				
13		/				
14		/				
15		/				
16		/				
17		/				
18	/		✓			
19		/				
20		/				
21		/				
22		/				
23		/				
24		/				
25		/				
26		/				
27		/				
28		/				
29		/				
30		/				
31		/				
32		/				
33		/				
34		/				
35		/				
36		/				
37		/				
38		/				
39		/				
40		/				
41		/				
42		/				
43		/				
44		/				
45		/				
46		/				
47		/				
48		/				
49		/				
50		/				
TOTAL IND.	2	↓		↓		↓
TOTAL DEP.	28	←		←		←
TOTAL CLAIMS	30					

	*		*		*	
	IND.	DEP.	IND.	DEP.	IND.	DEP.
51						
52						
53						
54						
55						
56						
57						
58						
59						
60						
61						
62						
63						
64						
65						
66						
67						
68						
69						
70						
71						
72						
73						
74						
75						
76						
77						
78						
79						
80						
81						
82						
83						
84						
85						
86						
87						
88						
89						
90						
91						
92						
93						
94						
95						
96						
97						
98						
99						
100						
TOTAL IND.		↓		↓		↓
TOTAL DEP.		←		←		←
TOTAL CLAIMS						

\* MAY BE USED FOR ADDITIONAL CLAIMS OR ADMENDMENTS