

# Digitally-Controlled RF Passive Attenuator in 65 nm CMOS for Mobile TV Tuner ICs

Ahmed Youssef and James Haslett

Electrical and Computer Engineering Department  
University of Calgary  
Alberta, Canada

Edward Youssefian

Newport Media Inc.  
Lake Forest, California, USA

**Abstract**—A novel VHF/UHF passive attenuator linearization circuit suitable for mobile TV applications has been designed and implemented in 65 nm CMOS technology. The proposed attenuator has a wide gain range of 48 dB that can be digitally programmed in 3 to 6 dB steps. At every gain setting, the input and output of the attenuator are matched to 50  $\Omega$  to facilitate its integration into mobile TV tuners.

## I. INTRODUCTION

Mobile TV is one of the latest features to be added to cell phones and other hand-held devices. The low cost, low power, and small size demands of this application have pushed researchers to use nanometer CMOS technologies in designing high performance tuner chip sets. The bulky RF filters (i.e., SAW filters) usually used in traditional TV-can tuners to suppress far-away interferer blockers are thus not an option for these integrated tuners. This results in tightening the linearity requirement of the RF front-end needed for mobile TV reception, and hence demands innovative design techniques to adhere to the low power necessities for this application [1].

The RF-AGC (Automatic gain control) technique has been proposed recently in the literature as one of the low power solutions that can help mobile TV receivers achieve their stringent linearity requirements [2]-[4]. Decreasing the RF gain at large input signal levels helps the receiver pass larger signals without any degradation in the output SNR (Signal-to-Noise Ratio). Although there are many mechanisms to vary the RF gain in receivers, the efficacy of any given mechanism depends on the amount of the dynamic range that can be achieved while decreasing the RF gain.

This paper proposes an RF attenuator linearization circuit used to vary the RF gain of mobile TV receivers while maximizing their dynamic range. The paper describes a passive attenuator designed, implemented in 65 nm CMOS technology and characterized in the lab. Additionally, a 5 bit linear thermometer decoder [5] integrated in the same test chip is used to program the gain of the attenuator. The decoder sets the gain value according to the signal level received at the attenuator input. Also, an on-chip programmable matching network is used to provide a stable 50  $\Omega$  input resistance

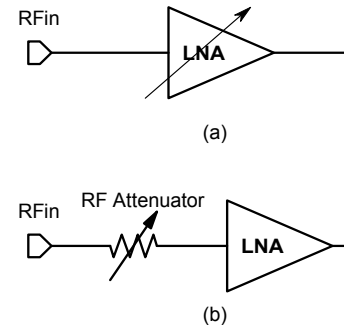

Figure 1. RF gain control through a) a variable gain LNA or through b) RF programmable passive attenuator.

to the mobile TV antenna for the entire gain range.

This paper is organized as follows. Section II discusses the advantages of using passive gain control over active gain control (i.e., Variable Gain (VG) LNA) to vary the RF gain of a mobile TV receiver. Section III presents the proposed RF attenuator design and demonstrates some practical issues dealt with in its integration with the rest of the mobile TV system. Measurement results are given in Section IV, and finally Section V draws the conclusions.

## II. PASSIVE GAIN CONTROL VERSUS ACTIVE GAIN CONTROL

There are several ways to achieve gain control in RF front-ends. Fig. 1a shows a VG-LNA used to control the RF gain, while Fig. 1b shows a programmable passive attenuator used to control the RF gain. Both techniques are capable of preventing a receiver from clipping at large input signal levels and, in theory, either one can be used to boost the linearity of a mobile TV tuner. However, the difference between them becomes clear when the receiver dynamic range (DR) is taken into consideration. Having the attenuator control (passive control) the RF gain results in a DR value that is far superior to that achieved when gain is controlled by a VG-LNA (active control), especially at the higher

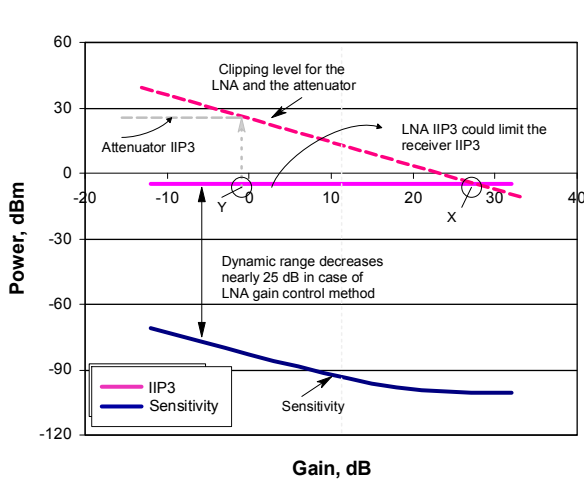

Figure 2. Simulation results show the impact of using the active gain control method versus the passive gain control on a receiver dynamic range.

attenuation (lower gain) settings.

The simulation results shown in Fig.2 illustrate the impact of using passive versus active gain control on receiver DR. In this simulation, the DR is assumed to be limited by third order nonlinearity (IIP3). When passive gain control is used, the clipping level and the system IIP3 improve by one dB for every one dB increase in the attenuation, and the dynamic range value is preserved. However, at certain gain settings (Y in Fig. 2), the system IIP3 will be limited by the attenuator IIP3 and therefore the DR will start to decrease. Passive gain control results in higher DR value than active control due to the fact that LNAs are generally less linear than attenuators, and thus DR decreases much earlier when gain is controlled by a VG-LNA (X in Fig.2). Therefore, using the attenuator to control the RF gain in this case maximizes the receiver dynamic range.

### III. RF PROGRAMMABLE PASSIVE ATTENUATOR

The design of an RF attenuator suitable for use in mobile TV applications presents several challenges. Such an attenuator has to achieve certain characteristics so that it can protect the RF performance of a mobile TV receiver in the presence of interferer blockers as high as 0 dBm. Typically, it should provide from 40 dB to 50 dB gain range in steps of 3-6 dB [6]. Also, it should have a 50  $\Omega$  input impedance to allow maximum power to transfer from the antenna or to provide the right termination for the GSM SAW filter. Additionally, it should provide a 50  $\Omega$  output matching so that it would not affect the LNA noise figure [7]. The input and output matching should remain constant throughout the entire gain range of the attenuator.

#### A. Binary Weighted Passive Attenuator

The design of the binary weighted attenuator network is shown in Fig. 3. The value of  $R = 50 \Omega$  was chosen so that the output matching to the LNA would be verified for every attenuation setting. There are eight control bits (vcont7-vcont0) to program the attenuator for different gain settings.

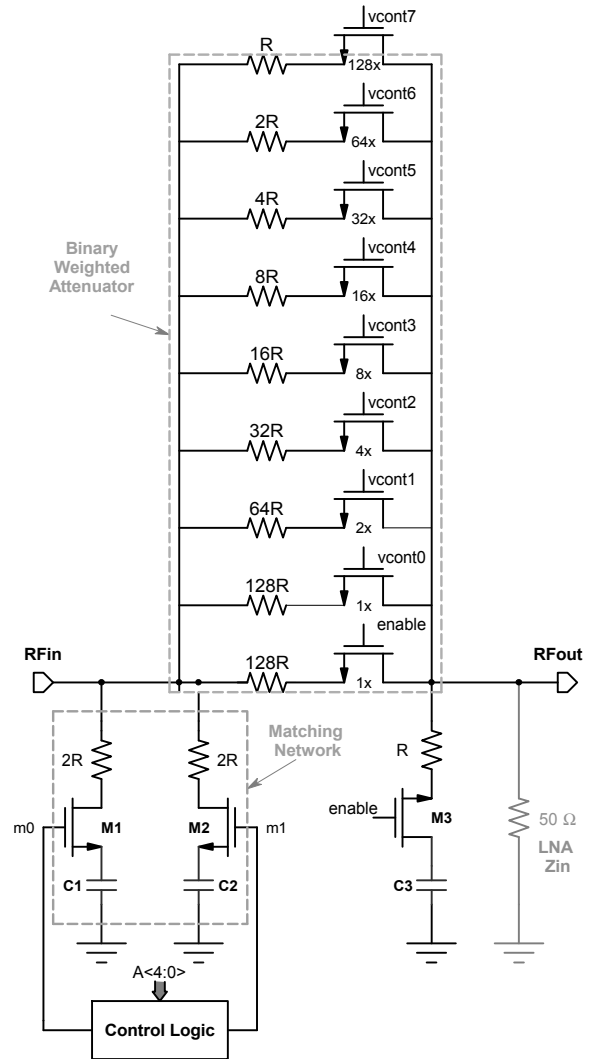

Figure 3. RF passive attenuator with the input matching network.

These control bits can be set in a thermometer code fashion in order to achieve 6 dB attenuation steps. The highest gain setting (-6 dB) is when all control bits are set HIGH and the lowest (-48 dB) is when they are set LOW. An enable bit is included to activate the attenuator path when it is necessary to improve the receiver linearity. All bits control the gates of NMOS switch transistors. Switch sizes were selected to minimize the off-state capacitance while still providing a sufficiently small resistance in the on-state compared to the resistance being switched. Although the binary weighted attenuator achieves the required gain range and also achieves the output matching requirement, it still needs to provide the matching to the mobile TV antenna.

A programmable matching network (shown in Fig. 3) was added at the input of the attenuator to provide the required input matching at different gain settings. This network can be programmed by two bits called m0 and m1 (see Table I). Adding the matching network modifies attenuation values of the binary weighted attenuator. However, as shown in Table I the attenuation step of 3 dB to 6 dB can still be achieved.

TABLE I. THE GAIN VALUES OF THE RF ATTENUATOR INCLUDING THE INPUT MATCHING

Input Matching		Decoder Input	Thermometer Decoder Output										Gain (dB)
m0	m1	A <4:0>	enable	vcont 7	vcont 6	vcont 5	vcont 4	vcont 3	vcont 2	vcont 1	vcont 0		
0	0	9	0	x	x	x	x	x	x	x	x	OPEN	
0	0	8	1	1	1	1	1	1	1	1	1	-6	
0	0	7	1	0	1	1	1	1	1	1	1	-9	
0	1	6	1	0	0	1	1	1	1	1	1	-13	
0	1	5	1	0	0	0	1	1	1	1	1	-18	
1	1	4	1	0	0	0	0	1	1	1	1	-24	
1	1	3	1	0	0	0	0	0	1	1	1	-30	
1	1	2	1	0	0	0	0	0	0	1	1	-36	
1	1	1	1	0	0	0	0	0	0	0	1	-42	
1	1	0	1	0	0	0	0	0	0	0	0	-48	

B. The Attenuator Bandwidth

Integrating the designed attenuator linearization circuit with the LNA requires some design modifications to avoid any undesirable interactions between the two. Connecting the attenuator to the LNA might create different DC paths for the LNA through the MOS switches M1, M2, and M3 (shown in Fig. 3) which might result in severe degradation of its performance. Therefore, AC coupling capacitors (C1, C2, and C3) are added to the attenuator to avoid any disturbances in the operating points of the LNA devices. It is of note that the capacitance values of these capacitors would set the lower frequency limit of the attenuator, which would be the VHF frequency for the mobile TV applications.

IV. MEASUREMENTS RESULTS

The proposed RF attenuator was fabricated in 65 nm CMOS technology. The MOS switches were designed taking their “on resistance” and their parasitic capacitance into consideration. The N-well-based MOS cap was used to implement the attenuator AC coupling caps to save the receiver die area. To support the VHF band, 70 pF and 30 pF capacitances were chosen for the attenuator (C3) and the matching network caps (C1&C2) respectively. The RF attenuator die photo is shown in Fig. 4. The fabricated chip consumes 0.05 mm<sup>2</sup> of silicon.

The attenuator die was characterized in the lab. The HP 8753D network analyzer was used for S-parameter measurements. The output matching of the attenuator to a 50 Ω resistance was tested by measuring S<sub>22</sub>. Fig. 5 shows the measured S<sub>22</sub> for different gain code settings across the UHF band. Measured values of S<sub>22</sub> were less than -13 dB for all gain settings across the UHF band. The same test was repeated to evaluate the attenuator input matching to a 50 Ω source resistance. Measured values of S<sub>11</sub> were less than -12 dB for all gain settings across the UHF band as shown in Fig. 6.

Noise analysis was conducted using the noise mode of the Agilent E4408B spectrum analyzer. Fig. 7 shows the NF measurements of the attenuator for all gain settings across the UHF band. The loss of the SMA connectors and the coax cable ranging from 0.7 dB to 1.2 dB was removed from the measurement. The NF measurements agree with the attenuation values reported in Table I.

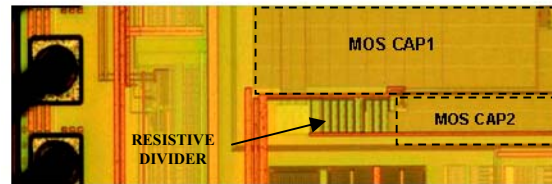

Figure 4. Die photograph of the proposed RF attenuator.

TABLE II. MEASUREMENT RESULTS SUMMARY.

Technology	65 nm CMOS	
Die area	0.05 mm <sup>2</sup>	
Power supply	1.2 V	
Noise Figure (NF)	max	48 dB
	min	5.8 dB
f <sub>c_low</sub>	100 MHz	
Gain steps	~ 3-6 dB	
S <sub>11</sub> for all gain settings	<-12 dBm	
S <sub>22</sub> for all gain settings	<-13 dBm	
In-band (IIP3)	max	+25.3 dBm
	min	+23 dBm

One of the most critical measurements for the attenuator is the third order nonlinearity (IIP3) since the receiver DR might be limited by this value at lower gain settings. A two-tone test was conducted by applying two tones that were spaced by 4 MHz. Fig. 8 illustrates a two-tone test measurement for one of the attenuator gain settings (-6 dB gain mode). The IIP3 is calculated to be +25 dBm. The same test was conducted for all gain settings of the attenuator. It was noticed that the IIP3 values degraded by 1 dB to 2 dB at lower gain settings (shown in Fig. 9). The measurement results of the RF passive attenuator are summarized in Table II.

V. CONCLUSION

A novel RF attenuator linearization circuit has been proposed to overcome the shortcomings of having the VG-LNA alone control the mobile TV front-end gain. The attenuator designed in 65 nm CMOS technology enables a low power, highly linear, wide dynamic range front-end realization with low noise figure at sensitivity level. The attenuator design can be scaled to any application that requires a wide dynamic range RF front-end.

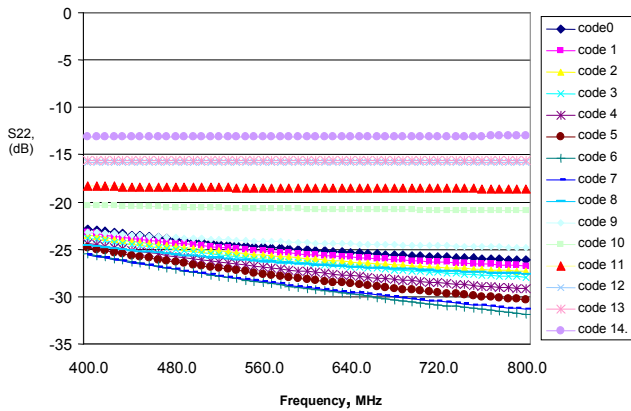

Figure 5. Measured output matching ( $S_{22}$ ) for different gain code settings. The frequency was swept from 400 MHz to 800 MHz.

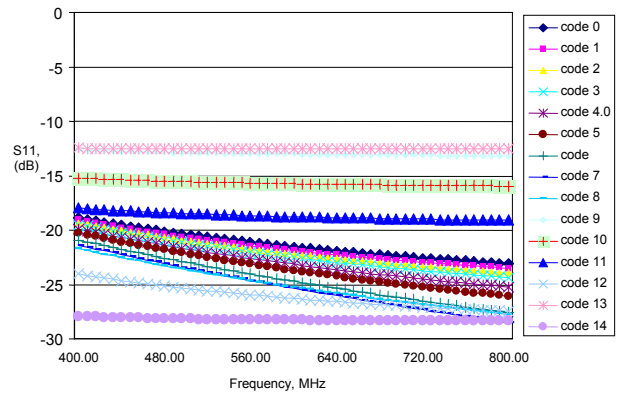

Figure 6. Measured input matching ( $S_{11}$ ) for different gain code settings. The frequency was swept from 400 MHz to 800 MHz.

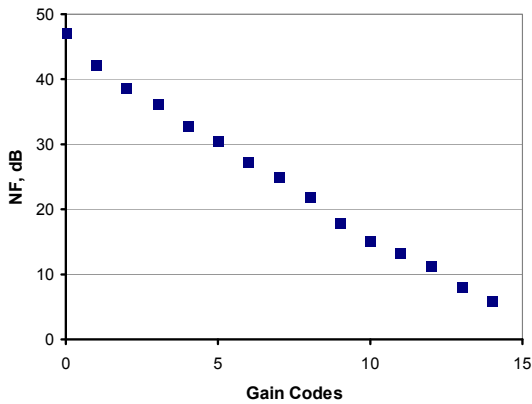

Figure 7. Measured  $NF$  for different gain settings.

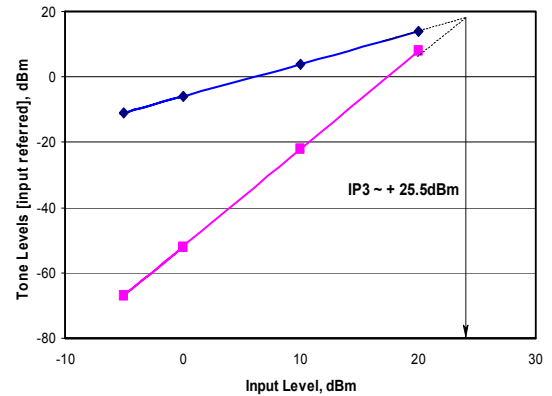

Figure 8. Linearity measurement for (-6 dB) gain mode.

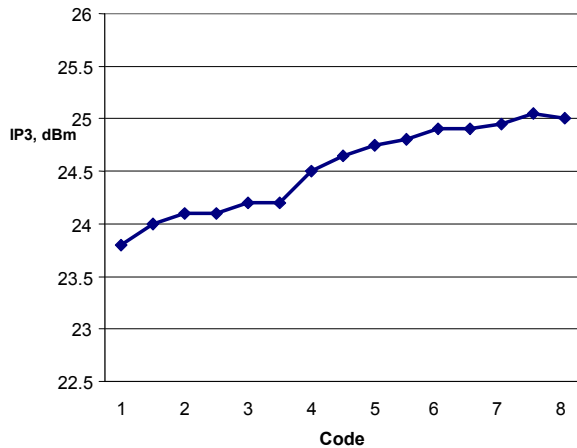

Figure 9. IIP3 measurement for different gain modes.

## REFERENCES

- [1] T. Shinyaitos, O. AlsushiSakail, M. Okazaki, M. Nagsumim, A. Saitow, K. Kioi, and M. Koutani, "A Digital TV Receiver RF and BB Chipset with Adaptive Bias-Current Control for Mobile Applications," *IEEE International Solid-State Circuits Conference*, San Francisco, pp. 212-213, February 2007.
- [2] Y.J. Kim, J.W. Kim, V.N. Parkhomenko, D. Baek, J.H. Lee, E.Y. Sung, and I. Nam, "A Multi-Band Multi-Mode CMOS Direct-Conversion DVB-H Tuner," *IEEE International Solid-State Circuits Conference*, San Francisco, pp. 2504-2513 February 2006.
- [3] M. Gupta, S. Lerstaveesin, D. Kang, and B.S. Song, "A 48-to-860MHz CMOS Direct-Conversion TV Tuner," *IEEE International Solid-State Circuits Conference*, San Francisco, pp. 2013-2024, February 2007.
- [4] V. Peluso, Y. Xu, P. Gazzero, Y. Tang, L. Liu, Z. Li, W. Xiong, and C. Persico, "A Dual-Channel Direct-Conversion CMOS Receiver for Mobile Multimedia Broadcasting," *IEEE International Solid-State Circuits Conference*, San Francisco, pp. 2524-2533, February 2006.
- [5] G.L. Radulov, P.J. Quinn, P.C.W. van Bee, J.A. Hegt, and A.H.M. van Roermund, "A Binary-to-Thermometer Decoder with Built-in Redundancy for Improved DAC Yield," *IEEE International Symposium on Circuits and Systems*, Kos, Greece, pp. 1414-1418, May 2006
- [6] A. Youssef, A. Ismail, and J. Haslett, "A sub - 2 dB Noise Figure LNA in 65 nm CMOS for Mobile TV Applications," *IEEE Radio and Wireless Symposium*, Louisiana, January 2010. "in press".
- [7] A. Youssef and J. Haslett, *Nanometer CMOS RFICs for Mobile TV Application*, Springer Publisher, 2010.